



**US ARMY
SIGNAL CENTER AND SCHOOL**
FORT MONMOUTH, N.J.

**SSTS 56007A*
INFORMATION SHEET
October 1964**

AUTOMATIC TELETYPEWRITER SWITCHING CENTERS

Section I. GENERAL

1. OBJECTIVE

To describe automatic teletypewriter switching centers used in the United States Army, the United States Navy, and the United States Air Force.

2. INTRODUCTORY INFORMATION

A step toward the day when messages will be transmitted to any place in the world "untouched by human hands" was taken a few years ago at Fifth Army Headquarters in Chicago, Illinois, when the US Army Signal Corps placed a prototype of a fully automatic teletypewriter switching center into operation. This was the first military relay center of this type. In addition to the automated features of the relay center, its speed of service was obvious. For example, the first few lines of a message relayed from the Pentagon to Fort Leavenworth, Kansas, were being received at Fort Leavenworth while the remainder of the message was still being transmitted from the Pentagon. In a matter of seconds, the relay center equipment was able to scan the incoming message, determine its precedence and routing, select the proper outgoing line, and begin relaying it.

* This information sheet supersedes SSTS 56007, Automatic Teletypewriter Switching Centers.

TABLE OF CONTENTS

<u>Para No.</u>	<u>Title</u>	<u>Page</u>
Section I. GENERAL		
1	Objective.	1
2	Introductory Information.	1
3	US Army System	3
4	US Navy System.	3
5	US Air Force System	3
II. BASIC THEORY OF AUTOMATIC SWITCHING		
6	General	4
7	Simplified Processing	4
8	Multiple Call Processing	7
III. AUTOMATIC SWITCHING CENTERS, US ARMY		
9	Features of Teletypewriter Central Office Set AN/FGC-30. . .	7
10	System Operation	9
11	Single Call Message (No Traffic in Center).	9
12	Single Call Message (Traffic in Center)	14
13	Use of Cross-Office Pool.	15
14	Single Call Message (High Precedence)	15
15	Single Call Message (Intercept).	16
16	Multiple Call Message	17
17	Multiple Point Operation	18
IV. AUTOMATIC SWITCHING CENTERS, US NAVY		
18	General	19
19	Features of the 82B1.	19
20	System Operation	21
21	Simplified Processing	23
V. AUTOMATIC SWITCHING CENTERS, US AIR FORCE		
22	General	25
23	Features of Plan 55	25
24	System Operation	28
APPENDIX I. SUMMARY CHART		32

3. US ARMY SYSTEM

a. Since the days of the prototype, the final model, Teletypewriter Central Office Set, AN/FGC-30 has been installed at Davis, California; Fort Leavenworth, Kansas; and Fort Detrick, Maryland. These are all major tape relay stations in the Army-operated element (STARCOM) of the Defense Communications System (DCS).

b. The installation at Davis, California (fig. 1), known as the WEST COAST RELAY STATION, became operational in May 1956, as a 100-line system.

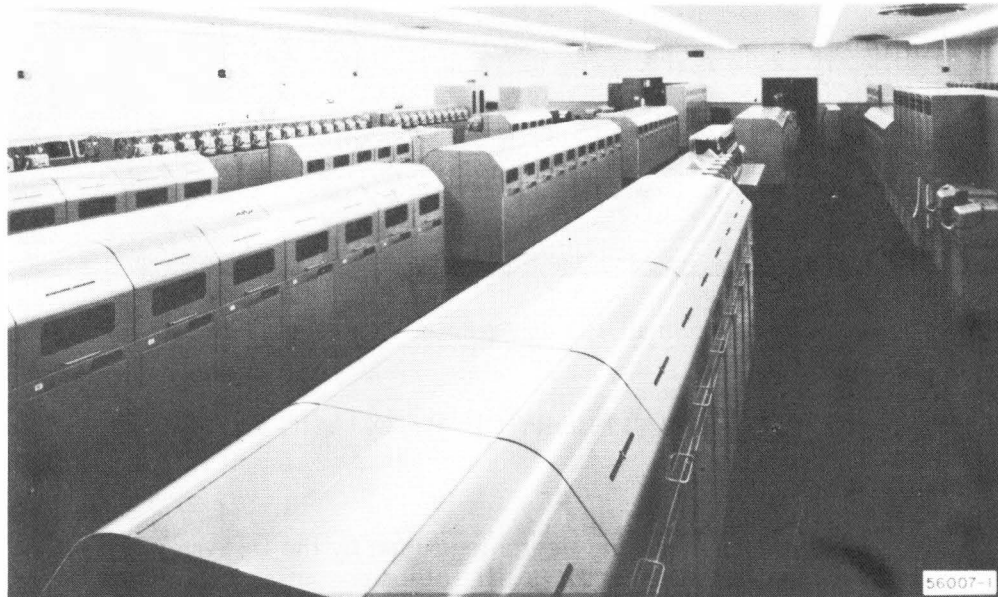

Figure 1. US Army station RUWP at Davis, California.

c. The second installation at Fort Leavenworth, Kansas, is known as the MIDWEST RELAY CENTER. It became operational in January 1960, as a 150-line system.

d. The third and final installation at Fort Detrick, Maryland, known as the EAST COAST RELAY STATION, became operational in April 1961. It is a 200-line system and is considered the largest, most advanced relay center used to process messages in tape form.

e. Each of the stations mentioned above includes not only the relay center but also its administrative and logistical support elements, and its associated radio receiver and transmitter sites.

4. US NAVY SYSTEM

The United States Navy is now using automatic switching equipment called the Bell 82B1 (figure 2 on page 4). This equipment is described in section IV.

5. US AIR FORCE SYSTEM

The United States Air Force also operates large communications centers which use automatic teletypewriter switching equipment. The switching equipment and teletypewriter equipment is known as the Plan 55, which is described in section V.



Figure 2. US Navy station RUEG at Trenton, New Jersey (Bell 82B1 system).

Section II. BASIC THEORY OF AUTOMATIC SWITCHING

6. GENERAL

a. Although the automatic switching equipment used by the US Army, the US Navy, and the US Air Force differs in many respects, it all solves essentially the same basic problem. (A chart comparing physical features of the three systems is shown in Appendix I.) The problem is to read and interpret information placed in the message heading so as to route the message, automatically, to the proper outgoing line. The switching equipment is designed so that human operators become necessary only in cases of emergency, when messages are garbled during transmission or are improperly prepared at the originating station.

b. The problem is complicated by the nature of military traffic. We must assign degrees of precedence (FLASH, IMMEDIATE, PRIORITY, ROUTINE) to messages; the switching equipment must distinguish between these degrees of precedence and must handle the message accordingly.

c. Figure 3 is a simplified block diagram of the basic theory of automatic switching. Figure 4 is an example of a message tape prepared at a tributary station for handling by an automatic switching center in accordance with the current procedures for tape relay operations, ACP 127 series. Refer to these illustrations as you read the following explanation of the basic operation.

7. SIMPLIFIED PROCESSING

a. When a message is transmitted from a distant station, it arrives in the automatic center at the incoming line unit (ILU). The ILU includes a tape reader that interprets the electrical impulses (Baudot Code) of the message which represent letters of the alphabet, numbers, and machine functions.

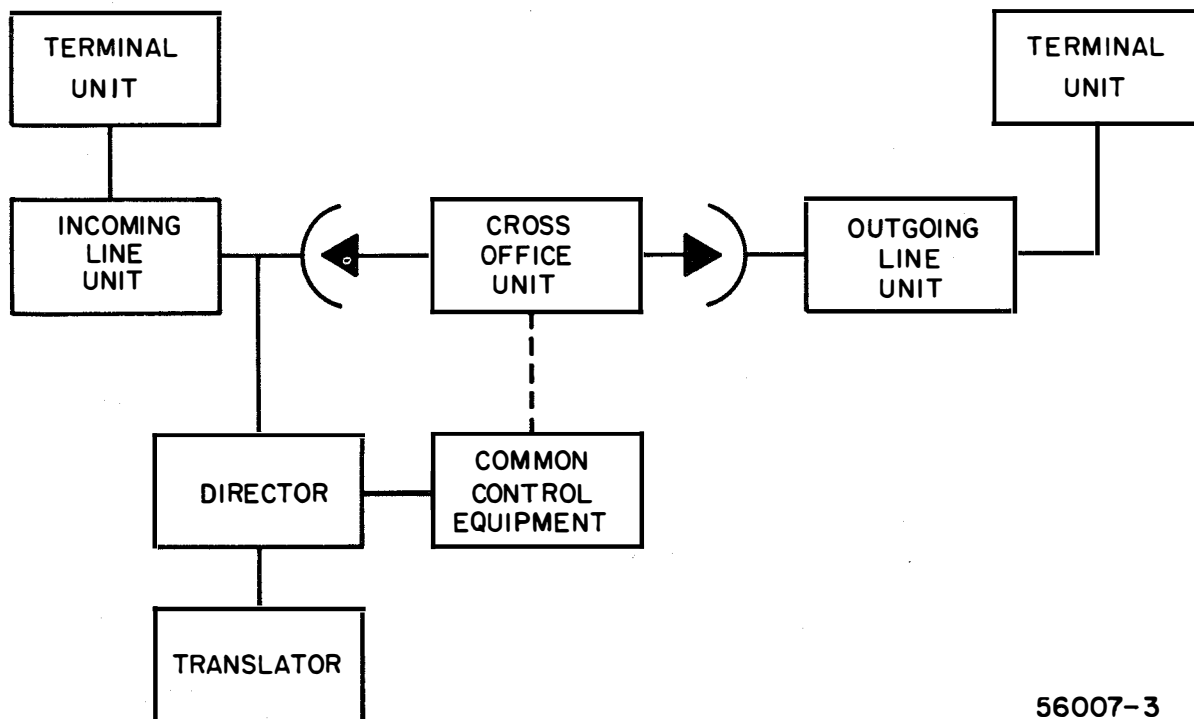

56007-3

Figure 3. Automatic message switching, block diagram.

b. The first characters of the message (fig. 4, pg 6) are the letters VZCZC. This group of letters is known as the start of message indicator (SOM). The SOM tells the equipment that a message is being received and activates the channel number comparator or sequence number indicator in the ILU. The channel number comparator checks the channel number (immediately after the SOM) of the message against the channel number in a register, contained in the comparator, to make sure that each transmission is received in sequence. If the channel number on the message tape corresponds to the number in the register, switching is permitted to continue. If the channel number does not correspond to the number in the register, an alarm directs an operator to the ILU to check the tape, determine the cause of disagreement, and then to take whatever action is necessary.

c. Let's assume that there is no difference detected in the channel number comparison. The tape reader continues on and reads the line feed (LF). This appears in a group of machine functions -- five spaces, two carriage returns, and a line feed (5SP 2CR LF) -- which is followed by a double letter indicating the precedence designation. When the LF function is read, the services of a DIRECTOR* are requested. The director stores the precedence designation for use later in the process. After registering the precedence designation, the director then stores the characters that follow. These characters make up the routing indicator. When there is more than one routing indicator in a message, the director registers one at a time. It reads each character of the indicator and stops when the space function (SP) is read. The director then requests the services of a translator.

d. The translator reads the characters of the routing indicator and translates them into a set of numbers which identify the proper outgoing line for that routing indicator. This information is furnished to the director, then the translator is released and again becomes available for translation.

*The word DIRECTOR as used in this text is a registered trademark of the Automatic Electric Company.

MESSAGE AS PREPARED BY OPERATOR

>>>> <<≡ RR >RUEPRM >RUEPRR << ≡ DE \\ \ TEX ≡ NNNN

MESSAGE AS TRANSMITTED

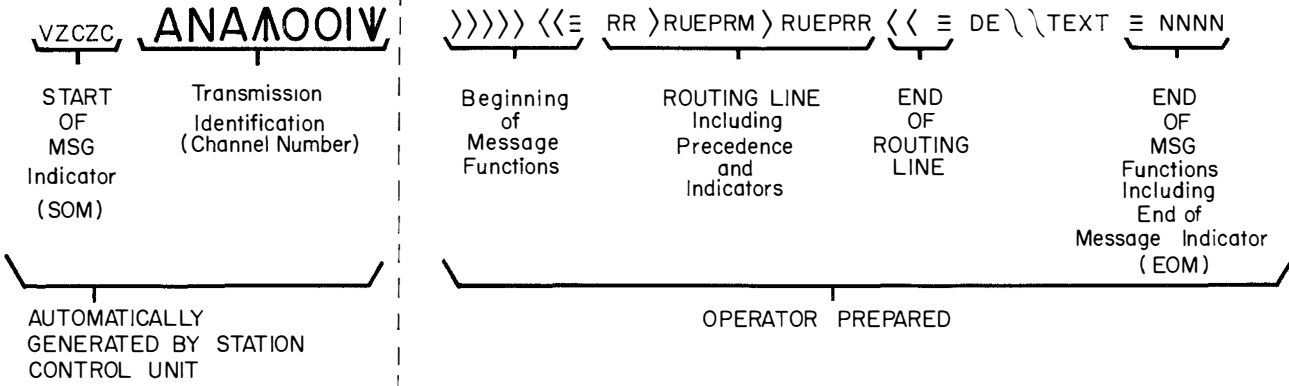

LEGEND

- \\ BLANK < CAR. RET.
- ▲ FIGURES ≡ LINE FEED
- ▼ LETTERS > SPACE

56007A-4

Figure 4. Sample message tape prepared by operator and automatically transmitted.

e. The director now has the identity of the incoming and outgoing lines and can set up a cross-office circuit or path between them. At this point, the precedence is brought out of storage (c above) and preferential handling is set up for high precedence traffic.

f. At this point, the director is no longer required, is disconnected, and becomes available for other incoming messages. Next a transmitter-distributor (TD) in the incoming line unit starts transmitting the message to the outgoing line over the cross-office circuit set up by the director. First, however, an outgoing channel number must be transmitted by a special transmitter in the outgoing line unit (OLU). As the message is being transmitted over the outgoing line, a monitor reel unit begins to operate and makes a copy of it.

g. As the message tape continues through the transmitter-distributor, the tape reader will eventually read the end of message functions which consist of two carriage returns, eight line feeds, four N's, twelve letters (2CR 8LF NNNN 12 LTRS). Two of the systems we are studying recognize LF and NNNN as the end of message indicator (EOM); the AN/FGC-30 recognizes 3LF NNNN as the EOM. The tape reader, when it senses the EOM, recognizes it as the end of the message and disconnects from the circuit. The tape reader is then available for other incoming traffic. Similarly, as the other units read the EOM, each, in turn, drops out of the circuit and becomes available for subsequent traffic.

8. MULTIPLE CALL PROCESSING

In the previous paragraph we were concerned with a single call message (one routing indicator). However, multiple address messages have two or more routing indicators and make up a large portion of military traffic. Some systems can handle messages with unlimited routing indicators; other systems are limited to a specific number of indicators. A multiple call message generally requires transmission over more than one channel, according to the routing indicators of the message. Therefore, an automatic center must prepare multiple tapes of the message, and transmit the message on the proper outgoing line for the distant receiving center. This process is called multiple call processing and is based on the routing line segregation method. However, a message containing more than one routing indicator does not always call for multiple call processing. For example, a message with five routing indicators may be transmitted over one outgoing line to a single distant automatic center, where the routing indicators are then segregated and broken down (a below). Multiple call processing and the production of multiple tapes at the automatic center are required only when the routing indicators indicate transmission to different distant centers over different outgoing lines (b below).

a. No Multiple Call Processing Required. Multiple address messages are processed the same as single address messages (para 7). However, when the director reads the routing indicator line of a multiple address message, it reads a routing indicator and a space and then goes to the next routing indicator. As an example, assume that a multiple address message containing three routing indicators enters the automatic center. The director reads the first routing indicator and transmits it to the translator where the routing indicator receives outgoing line identification number 527. Immediately after the space (SP), the director reads and transmits the second routing indicator to the translator and again receives an indication of outgoing line 527. The director again reads a space and then the third and last routing indicator. It transmits this last routing indicator to the translator and again receives an indication of outgoing line 527. The director now reads two carriage returns (2CR), a line feed (LF), and the letter D or the letter Z of the next format line (DE or a Z signal). The LF function and the character D (or Z) indicate that there are no additional routing indicators. Multiple call processing is not required at this center because the translation of each routing indicator in the message produced the same outgoing line identification -- 527. However, multiple call processing will be required at some subsequent automatic center where translation of the routing indicators does not produce the same outgoing line identification (b below).

b. Multiple Call Processing Required. Assume again that a message containing three routing indicators enters the automatic center and processing begins. The director transmits the first and second routing indicators to the translator and receives the same outgoing line identification number -- 527 -- for both indicators. However, when the director transmits the third indicator to the translator, it receives an indication of outgoing line 545. The director compares the indication 527 against the indication 545, recognizes the difference, and puts multiple call processing equipment into operation without reading any subsequent routing indicator.

Section III. AUTOMATIC SWITCHING CENTERS, US ARMY

9. FEATURES OF TELETYPEWRITER CENTRAL OFFICE SET AN/FGC-30

a. Fully Automatic Operation. This equipment is fully automatic. It receives incoming messages and routes them to suitable outgoing lines without manual intervention. Manual processing is needed only when improperly prepared messages preclude handling or when messages are addressed to supervisory personnel. On marginal radio circuits, operators monitor the traffic before processing can take place.

b. Single Installation in Network. We can install this equipment at any point within a tape relay network, since it does not require similar equipment to be located at other points. This feature enables us to install automatic equipment on a station-by-station basis.

c. Compatibility. The AN/FGC-30 is compatible with Navy and Air Force automatic equipment and permits free interchange of traffic among the three systems.

d. Routing Indicator Plan. The current routing indicator plan in ACP 121, Communications Instructions, General, is recognized by this system. Routing indicators can be reassigned within the system as changes occur in the plan.

e. Three-Speed Operation. The system can receive and transmit messages at any of the three standard speeds of 60, 75, or 100 words per minute, and can use all three speeds at once.

f. Three-Speed Cross Office. This equipment requires a cross-office speed only slightly higher than the highest speed on the incoming line. We can set normal cross-office speed at 75, 100, or 115 words per minute, as required by the highest incoming line speed.

g. Immediate Handling of Message Traffic by Maximum Use of Current Facilities. The system makes maximum use of pooled and common equipment to keep a particular outgoing line in use as long as there is traffic destined for that line. All traffic received by the AN/FGC-30 is switched immediately from the incoming line to a cross-office position. This action keeps incoming lines free to receive traffic at all times.

h. Precedence. The system acts upon all four categories of military precedence, transmitting messages to outgoing lines in accordance with the precedence designation placed on the message. That is, IMMEDIATE will be handled before PRIORITY, and PRIORITY before ROUTINE.

i. Handling of High Precedence Traffic. Two degrees of high precedence -- FLASH and IMMEDIATE -- require immediate, expeditious handling. If a message of lower precedence is being transmitted on an outgoing line, the transmission must be interrupted to make way for high precedence traffic. This system automatically interrupts the circuit and sends a CANTRAN (cancelled transmission) to cancel the transmission. It then sends the message of higher precedence. When this condition occurs, an alarm appears on the supervisor's console as well as on the cross-office unit which had seized the outgoing line for the message of lower precedence. An operator, dispatched by the supervisor to the proper cross-office unit, simply repositions the message of lower precedence so it can be started again through the cross-office unit when the outgoing line becomes available.

j. Continuity of Traffic. The system automatically checks the transmission identification (channel-number sequence) at the incoming line before it allows a message to continue through the system. Disagreement between channel sequence on the message and the channel sequence counters in the incoming line unit activates an alarm. Further handling of the message is halted before transmitting to a distant center over an outgoing line, and an outgoing channel number is automatically transmitted by the monitor unit.

k. Message Control. A complete alarm system protects continuity throughout the system. The alarm system indicates any improper function of the equipment or any improperly prepared incoming message tape to supervisors and maintenance personnel.

l. Intercept Positions. If messages are improperly prepared and contain garbled or unrecognizable characters in the precedence or routing indicators, the system directs them to intercept positions where they are examined and necessary supervisory action is taken.

m. Manual Forwarding Positions. Several manual forwarding units at each manual forwarding position are provided to transmit service messages, reruns, or tapes to the intercept position. The operator indicates the precedence of the message and uses a control panel to select the outgoing line to be used to manually forward the message. The outgoing line is seized in accordance with the precedence indicated by the operator.

n. Multiple Call Messages. The system handles multiple call messages automatically in accordance with precedence and processes them on a routing line segregation basis. There is no limit to the number of routing indicators the system can process in each message. In dual precedence messages, however, the system will only recognize and act on the highest precedence.

o. Multi-Point Operation. The system provides for the operation of a multi-point circuit with as many as ten stations per circuit operating on a full-duplex basis.

p. Multi-Channel Selection. We can use any number of channels to any distant center and traffic will be distributed equally to all channels of the group. We can subtract channels from the group and still leave the traffic distributed equally among the remaining channels.

q. Alternate Routing. Temporary alternate routes can be established.

r. Torn-Tape Emergency. If the switching equipment fails completely, the remaining equipment can be operated as a torn-tape system. When operated as a torn-tape system, however, automatic numbering facilities are not available and tab numbering must be used.

s. Other Features. Other features of the AN/FGC-30 include ease of maintenance; use of the completely perforated, printed, wide tape; a high degree of message reliability; the ability to receive either 20 or 30 mils polar or 60 mils neutral operation; a supervisor's console to determine which units of the system are temporarily tied together for a particular message; a cross-office unit numbering system to help operators trace messages through the system; and ease of expanding the system. The AN/FGC-30 was designed on a building block principle and permits expansion to a maximum of 250 lines.

10. SYSTEM OPERATION

The following paragraphs describe how the AN/FGC-30 performs the basic procedures described in section II. The different handling accorded to different types of messages is described in separate paragraphs.

11. SINGLE CALL MESSAGE (NO TRAFFIC IN CENTER)

Let's assume that there is no traffic in the center and that the single call message we are about to process is the only message being sent through the center. The incoming message is sent from the receiver station to the relay station over the control link, which is normally a microwave relay circuit. At the relay center the message first appears at the terminal unit (fig. 5). The terminal unit provides access jacks to monitor the incoming and outgoing circuits and to permit patching. Patching enables us to interconnect different channels with various incoming units. The system then handles the message in the following manner:

a. The message leaves the terminal unit and enters the incoming line unit (fig. 6, pg 11) in accordance with the patching scheme of the terminal unit. At the incoming line unit a reperforator cuts a tape in accordance with the incoming message signal. As the tape is perforated, it is advanced through a tape reader until the start of message indicator (SOM) is reached.

b. The SOM consists of the letters VZCZC. (See figure 4.) When the tape reader registers the SOM, the channel-number comparator of the incoming line unit is activated. The channel-number comparator checks the channel number following the VZCZC on the tape. If the channel number on the tape agrees with the channel number in the comparator's register, the message goes on to further processing.

c. If the channel numbers do not agree, an alarm is activated at the supervisor's console (fig. 7, pg 12) and also at the incoming line unit. Upon receipt of the alarm, the supervisor calls an operator over the public address system. The operator goes to the incoming line unit,

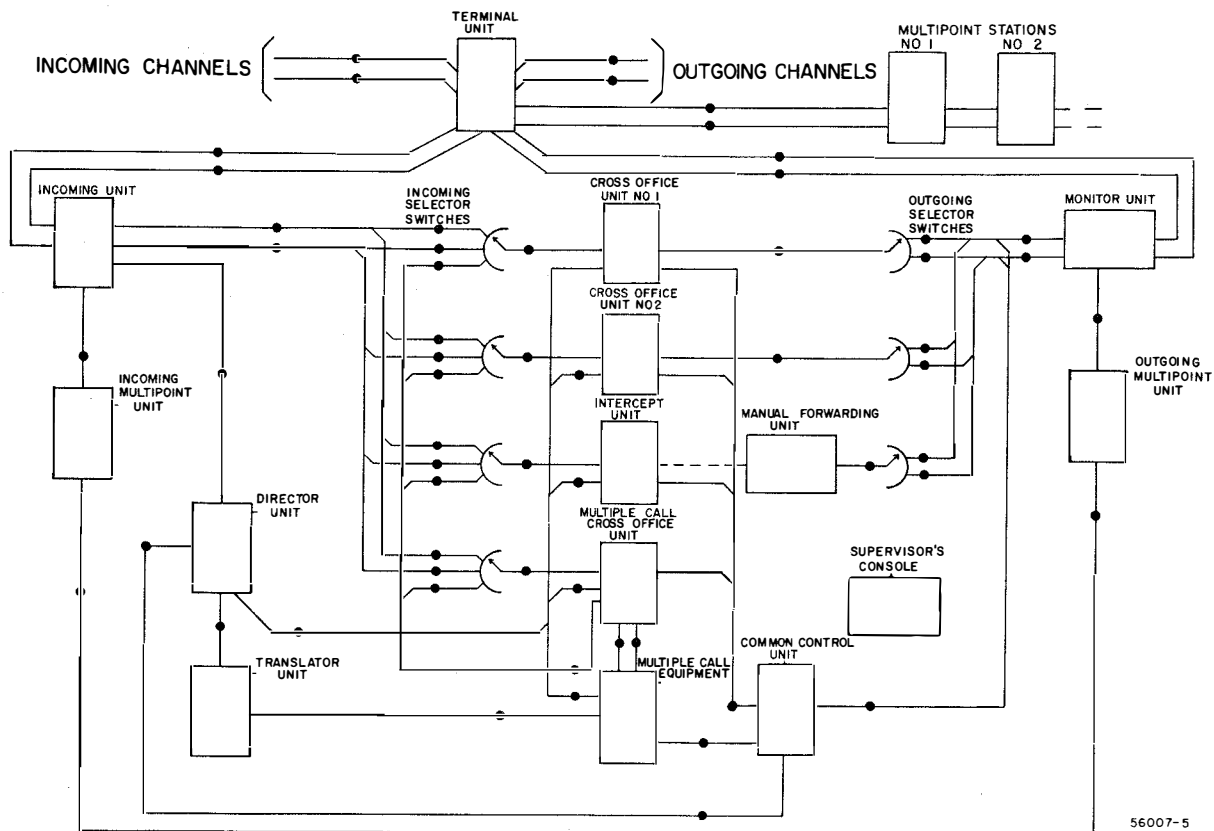

Figure 5. Block diagram of AN/FGC-30.

examines the channel number on the tape and takes the necessary steps to clear the alarm. (The scope of this text does not permit us to go into the specific operating procedures, but we will indicate how certain operations are performed.)

d. If the channel numbers agree, the incoming line unit calls for a director. Two directors are used to accommodate a total of 25 incoming line units and operate to accept inputs in accordance with the channel numbering sequence of the message.

e. The director first records the precedence indicator and the routing indicator, then demands the service of the translator unit which is common to all switching center directors. When it seizes the translator, the director transfers the routing indicator to it. Based on the routing indicator information, the translator determines which outgoing line to use to transmit the message and sends the outgoing line identification back to the director. The director then reads a line feed (LF) and the letter D (or Z) of the next format line -- the example message (fig. 4) has only one routing indicator -- which indicates that the director is finished with the translator. The director releases the translator unit.

f. Now the director knows the incoming and outgoing line identifications and must find a cross-office unit (fig. 8, pg 13) to use to interconnect them.

NOTE: During normal operation with many messages being processed through the center, the preset test and the empty bin test (para 13 and 15) are performed at this time. However, since we've assumed that the example message is the only one being processed, we can state that the director need only find a cross-office unit (COU).

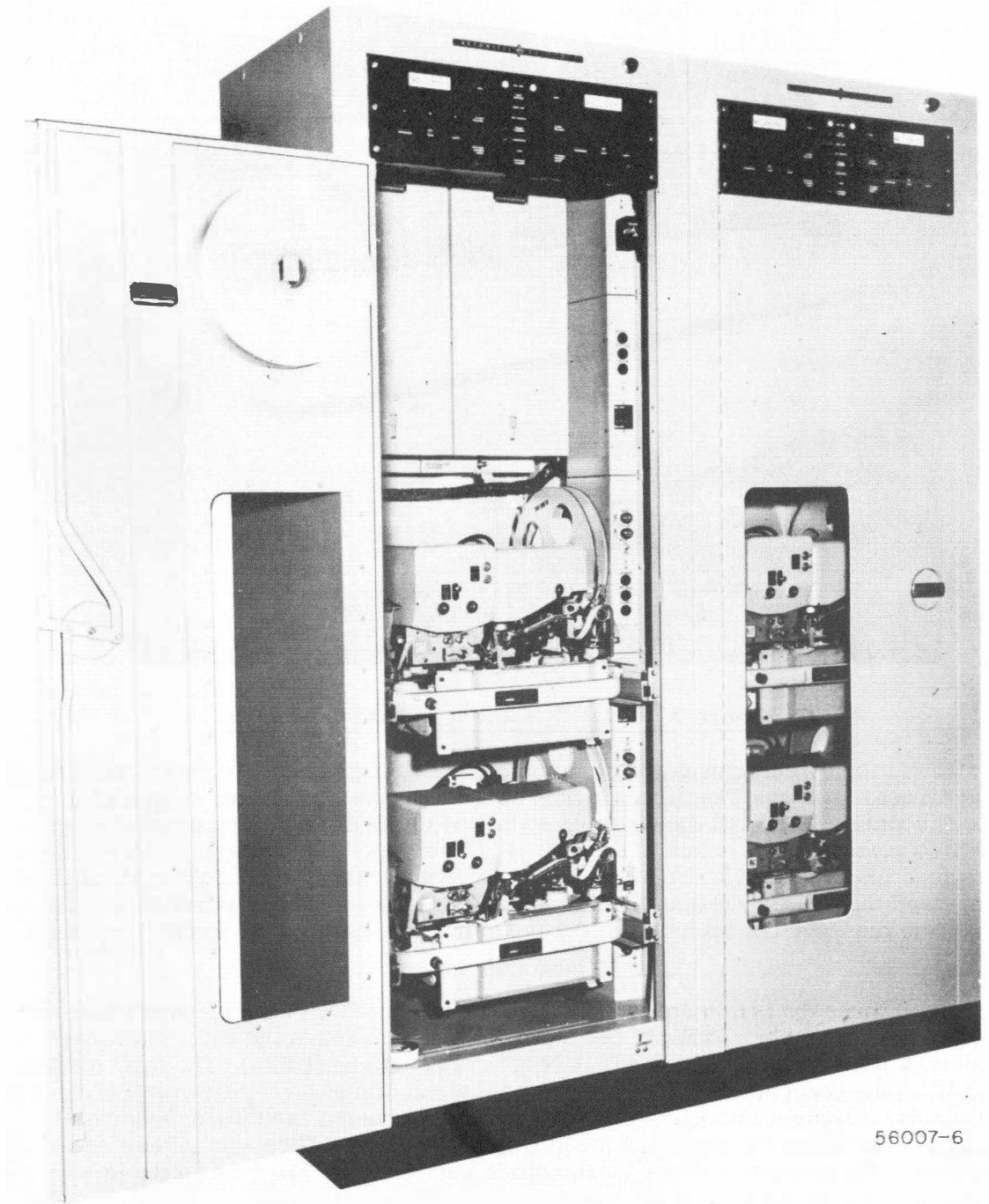

56007-6

Figure 6. AN/FGC-30: incoming line unit.

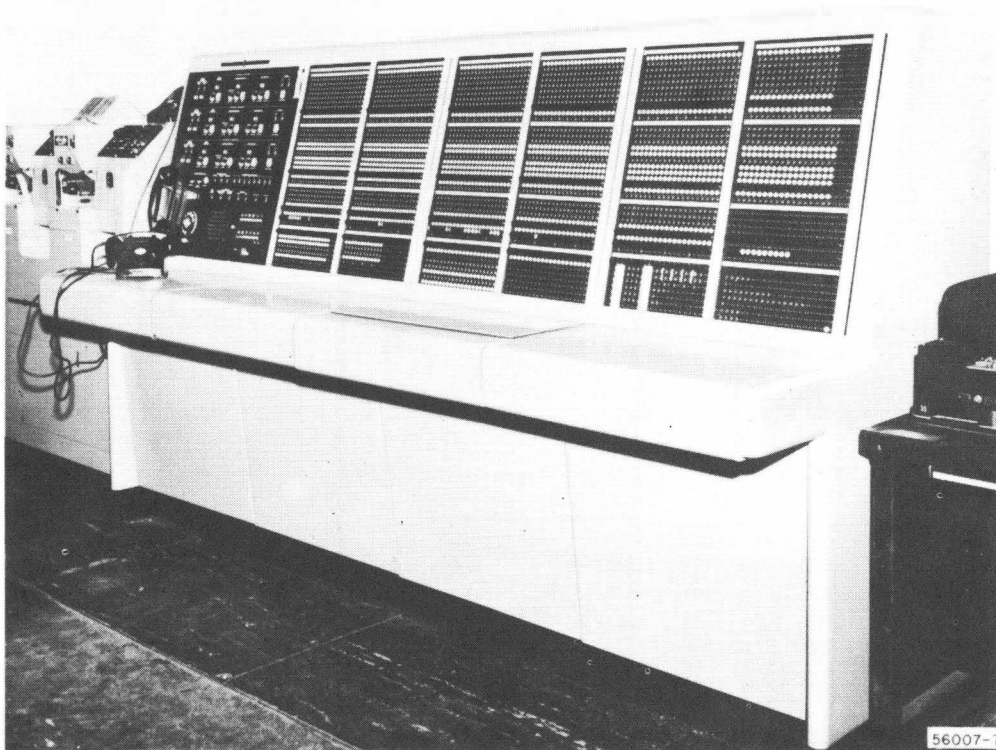

Figure 7. AN/FGC-30: supervisor's console.

To find a COU, the director uses the common control unit to select an empty and idle COU which the director seizes. The director then sets the incoming selector switch of the COU to the proper incoming line, and the outgoing switch of the COU to the proper outgoing line. The director also sets the precedence of the message into the cross-office unit. Having accomplished its function in about four to six seconds -- considerably less time that it takes to read and understand the process -- the director is no longer required and is released. The transmission of the message continues from the incoming line unit to the reperforator of the cross-office unit.

g. As the message is transmitted through the tape reader of the incoming line unit to the cross-office unit, the tape reader of the incoming line unit reads the end-of-message functions, 2CR (carriage return), 8LF (line feed), 4 N's, and 12 letters (LTRS). The tape reader of the incoming line unit recognizes 3LF and 4 N's as the end of message indicator (EOM). The EOM indicates to the incoming line unit that it is no longer required, and it becomes free to process other traffic. The incoming line selector switch of the cross-office unit is then reset. (Remember, however, that the action in the cross-office unit is taking place while the message is coming through the incoming line unit to the cross-office unit.)

h. We shall assume that up to this point the complete message has not necessarily been received at the incoming unit. Let us now see what occurs as this message is received from the incoming line unit into the cross-office unit reperforator. As the tape is being perforated, in the cross-office unit, the tape reader continues to read the tape until it senses the SOM.

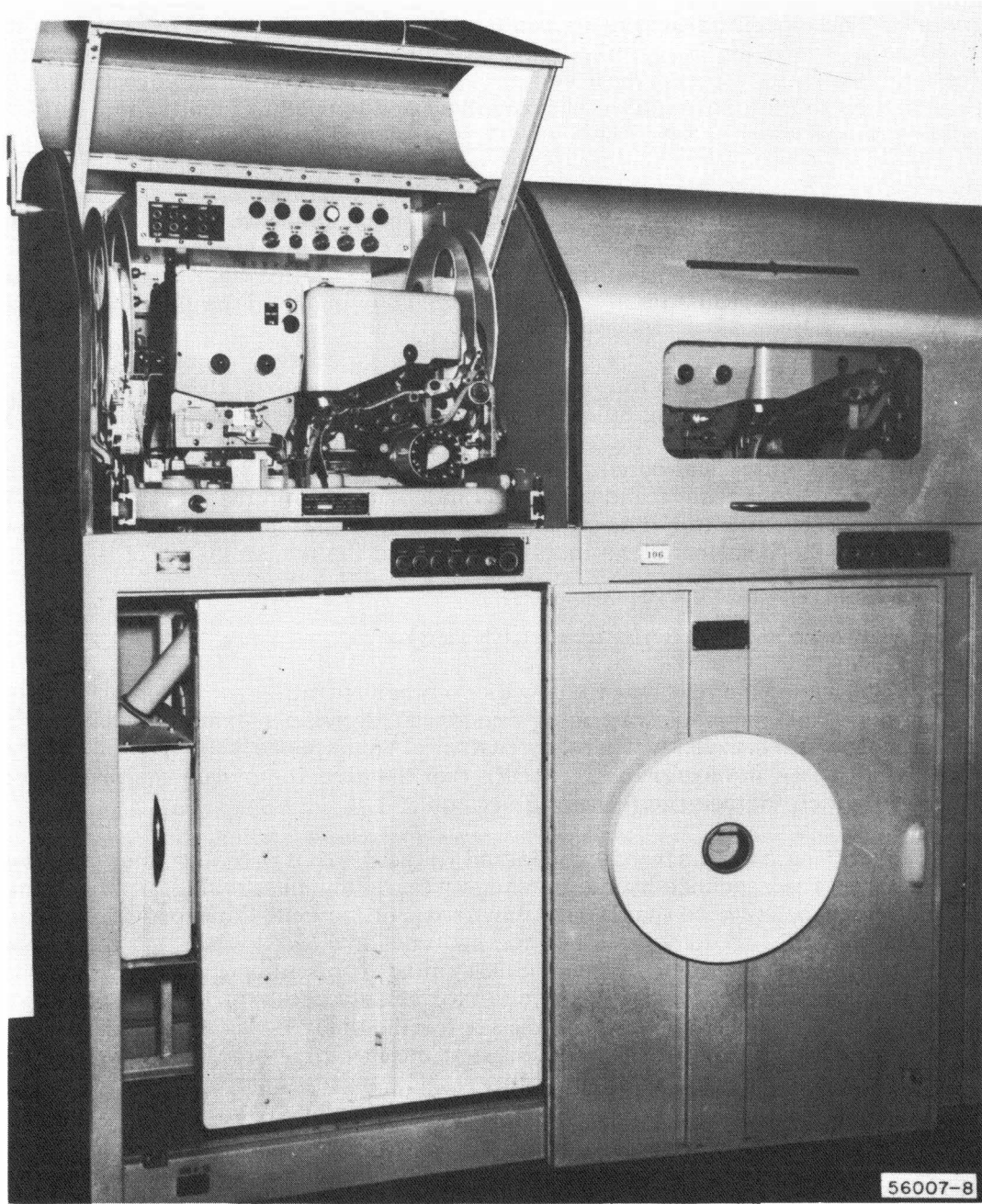

Figure 8. AN/FGC-30: cross-office unit.

Upon recognizing the SOM, the cross-office unit demands the outgoing line to which its selector switch had been set by the director. Since there is no traffic in the center, this outgoing line is readily available and the COU seizes it.

i. Immediately upon seizure of the outgoing line, a special transmitter in the monitor unit is activated. This special transmitter sends a new start of message indicator to the outgoing line. While this is being done, a special transmitter temporarily associated with the cross-office unit transmits a three-digit serial number to the monitor reperforator. This is the number assigned to the cross-office unit involved and is used to identify that unit. The number appears on the monitor tape, but is NOT transmitted to the outgoing line.

j. Since every transmission in the tape relay network between relay stations must be preceded by a transmission identification (channel number), a new outgoing channel number is transmitted to the distant station and is also perforated on the monitor reel. After this has been done, the message is transmitted from the cross-office unit transmitter to the outgoing line. A monitor tape of the transmission is simultaneously made on the monitor reel (fig. 9, pg 15).

k. As stated in g above, when the incoming line unit recognizes the end of message indicator, it drops out and the incoming selector switch of the cross-office unit is reset. Then the end of message indicator is read in the cross-office unit, its outgoing selector switch is also reset. With both its incoming and outgoing selector switches reset, the COU has completed its function in processing the message and again becomes available in the COU pool. Finally, the special transmitter in the monitor unit transmits the end of message sequence to the outgoing line. This completes the function of the monitor unit, and the transmission of the single call message is complete.

12. SINGLE CALL MESSAGE (TRAFFIC IN CENTER)

In paragraph 11, we assumed that there was no other traffic in the automatic switching center while a single call message was being processed. Now let's examine what happens when a single call message is received while other traffic is being processed. The equipment functions are the same as in paragraph 11 except that the director makes the preset test and the empty bin test which include the following actions.

a. If a cross-office unit is already connected to the desired outgoing line, and is also set for the same degree of precedence as the message we are now processing, it is advantageous to route the incoming message to that particular cross-office unit. This provides a saving of time and functioning in the equipment, since the switches are already set and the cross-office unit can immediately accept our message. To determine if this situation exists, the director makes a preset cross-office unit test. If the director finds a cross-office unit already connected to the desired outgoing line and already set for the desired degree of precedence, and also notes that it is not busy receiving a message at the incoming side, the director seizes the unit and causes the message to be transmitted to it. The message goes into storage behind the earlier outgoing message.

b. When the earlier message has been transmitted, the outgoing line becomes idle for a brief interval. In this interval, all the cross-office units whose switches have been set to the same outgoing line will demand the line. The cross-office unit whose switch is set to the highest degree of precedence will actually seize the outgoing line. Since this process is repeated after the transmission of each individual message, transmissions take place according to precedence.



Figure 9. AN/FGC-30: monitor reels.

13. USE OF CROSS-OFFICE POOL

The following facts apply to the cross-office pool as used in the operation of the AN/FGC-30:

- a. Any cross-office unit may be set to any line.
- b. Any number of cross-office units may be set to any line.
- c. Any cross-office unit may be set to any degree of precedence.
- d. At no time will any one cross-office unit contain messages of more than one degree of precedence.
- e. At no time will any one cross-office unit contain messages destined for more than one line.
- f. Many messages may be stored in any one cross-office unit provided they are destined for the same line and carry the same degree of precedence.
- g. When a line is idle, it is demanded simultaneously by all cross-office units set to that line; only the unit set to the highest degree of precedence will be permitted to seize the line.

14. SINGLE CALL MESSAGE (HIGH PRECEDENCE)

The explanation in a through d below covers the operation of the AN/FGC-30 when a single call message of high precedence (FLASH or IMMEDIATE) is received. In the explanation, assume that a FLASH message is received while a ROUTINE message is being transmitted.

a. A high precedence single call message (FLASH, in this case) is received on an incoming line. The AN/FGC-30 operates as in paragraph 11, however, the director registers the precedence prosign that this is a FLASH message. Instead of making a preset test, the director makes an empty-bin test and immediately seizes an empty cross-office unit. The director, as before, sets the incoming and outgoing selector switches of the COU to the proper outgoing line. It also sets the precedence switch of the COU to FLASH.

b. When the message is ready to be transmitted, examination of outgoing lines indicates that the desired line is busy transmitting a ROUTINE message. In accordance with tape relay procedures as outlined in ACP 127(), a FLASH message requires interruption of the line transmitting a message of lower precedence. To interrupt this transmission, a cancellation sequence must be sent over the outgoing line to the distant station. This is known as a CANTRAN. It consists of 8 spaced E's followed by AR and the routing indicator of the station making the cancellation, e. g., E E E E E E E E AR RUEP. To transmit this cancellation sequence over the outgoing line, a special transmitter is called into use.

c. After the CANTRAN has been transmitted, the outgoing line becomes idle for a brief interval. In this interval, all cross office units which are set to the line will demand the line, and the unit containing the FLASH message will seize it. A new channel number is then transmitted by the special transmitter in the monitor unit.

d. The ROUTINE message which was interrupted remains in its cross-office unit; however, a lamp alarm lights up on the cross-office unit to indicate the presence of a cancelled message. On this signal, a cross-office unit operator repositions the ROUTINE message tape back to its starting point, then clears the alarm by pressing the alarm release button. The cross-office unit is now ready to demand the outgoing line when it becomes available after transmission of the FLASH message. When the ROUTINE message is subsequently transmitted to the outgoing line, a new channel number will be transmitted by the special transmitter in the monitor unit. The action is then complete.

15. SINGLE CALL MESSAGE (INTERCEPT)

For the following discussion, assume that a single call message which requires interception has arrived at the AN/FGC-30 and is being processed as in paragraph 11. In this instance, however, when the routing indicator is transmitted from the director to the translator unit, the translator unit is unable to associate an outgoing line with that routing indicator. This could result from garbling in transmission or from errors made by the originating tape poker. Whatever the cause, when the translator is unable to find a suitable outgoing line indication from the routing indicator, the translator directs that the message be transmitted to an intercept position.

a. In accordance with the translator direction, the director seizes an intercept unit and sets the switch of the unit to the proper incoming line unit. Having performed this function, the director is no longer required and is released.

b. Upon release of the director, the message is transmitted from the incoming line unit to the intercept unit. An intercept operator examines the tape to determine the reason for routing to intercept, reconstructs the proper or garbled indicator, and punches the proper heading. The corrected tape is then taken to the manual forwarding unit and the message is reintroduced into the center.

c. At the manual forwarding unit (fig. 10), the operator selects a degree of precedence corresponding to that of the message and a transmitter to receive the message tape. He then sets a selector switch to position the unit to the proper outgoing line. These actions make the manual forwarding unit electrically identical to a cross-office unit. The manual forwarding unit will demand the selected outgoing line and seize that line as previously described. With seizure of the proper outgoing line, the message is automatically transmitted. This completes the action of single call message intercept.

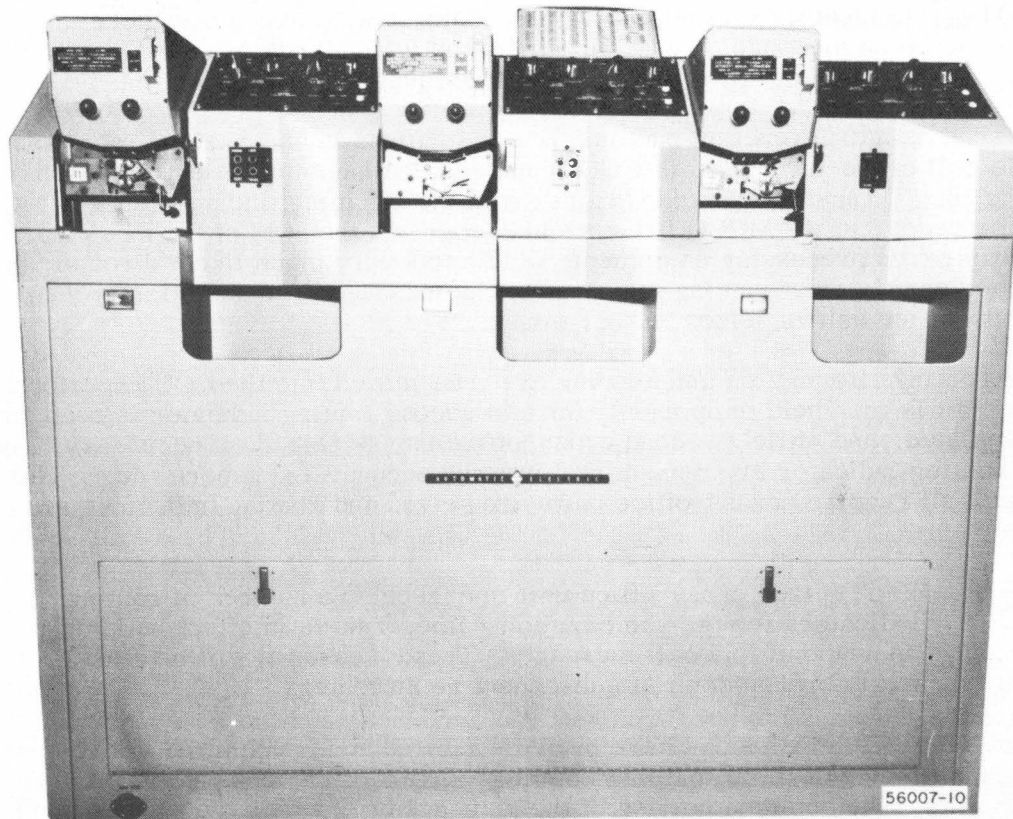

Figure 10. AN/FGC-30: manual forwarding unit.

16. MULTIPLE CALL MESSAGE

The AN/FGC-30 processes a multiple call message in the same manner as it does a single call message up to the point at which the director reads the routing indicators (para 11a through d).

a. The director reads the routing indicator and then requests translation as in paragraph 11e. The translator makes the necessary translation of the routing indicator and indicates an outgoing line. In a single call message, the tape reader would then read a line feed followed by the letter D or Z. This combination of LF and D or Z would indicate that there were no other routing indicators to come. In a multiple call message, however, after reading the first routing indicator the tape reader does not read LF and D or Z, but continues to read a second routing indicator. The translator translates the second routing indicator and again indicates an outgoing line. The second outgoing line indication is then compared to the first. If they differ, the system senses immediately that the message requires multiple call processing.

b. If the outgoing line indications are the same, the tape reader continues to read the tape. If it reads LF and D or Z, then no multiple call processing is indicated and the message is treated in the same manner as a single call message. However, if the tape reader does not read LF and D or Z, it will then read a third routing indicator. This third routing indicator is then sent to the translator for translation and an outgoing line indication is received. Again, a

comparison of the outgoing line indication is made. If these indications differ, then multiple call processing is required. If they do not differ, no multiple call processing is indicated up to this point, and the process continues until all routing indicators have been checked.

NOTE: Remember that no matter how many routing indicators there are on a message, translation will stop just as soon as there is a difference in two outgoing line indications.

c. As soon as a difference in outgoing line indications is noted, the director seizes an idle multiple call cross-office unit (MCCOU) and sets its incoming selector switch to the proper incoming line. Transmission then begins from the incoming line unit into the MCCOU. When the tape reader in the MCCOU reads and recognizes the SOM of the message, it demands a set of multiple call processing equipment, which acts very much like a director. It stores the precedence and the first routing indicator of the message. A translation is then made and a suitable cross-office unit is seized.

d. The routing information and heading are transmitted into the COU reperforator. The cross-office unit is then held temporarily while a second routing indicator is read from the tape and translated, and while a second cross-office unit is seized, if necessary. The heading and second routing indicator are transmitted into the second COU reperforator. This process continues until all required cross-office units are seized and routing indicators are distributed as required.

NOTE: Each seized cross-office unit may receive a number of routing indicators for the same outgoing line. This is in effect building up new multiple call messages. These messages will be similarly broken down at subsequent relay centers.

e. When all routing indicators have been distributed and transmitted to cross-office units, a multiple transmission of the remaining common portion of the message is made to all seized cross-office units. The common portion of the message begins with the format line beginning with DE. When multiple transmission begins, the multiple call processing equipment is no longer required and is released for processing of other multiple call messages.

f. A page printer is associated with each set of multiple call processing equipment. Just as in semi-automatic operation, the page printer records the heading of the original message and the heading of the tapes produced by the multiple call processing unit. A supervisor then monitors all transactions to make sure that all stations called in the routing line have been protected by proper routing and inclusion on the multiple tapes produced.

g. Transmission to the individual outgoing lines is in accordance with the operations described in previous examples.

17. MULTIPLE POINT OPERATION

a. In multiple point operation, as many as ten individual tributary stations are connected to a single circuit, but only one station at a time may transmit into the relay center, and then it may send only one message before it must yield to another station.

b. When a multiple point station has traffic to send to the switching center, it sends a signal over the loop into the incoming multiple point unit. This signal causes the outgoing multiple point unit to send a signal of selective sequence to the remote station. This selective sequence signal selects the remote station to transmit its message and causes all other stations in the loop to be "locked out". When the message from the remote station arrives at the switching center, the channel number of the message is checked against the appropriate channel number register for that station. Processing throughout the center continues as in previous examples.

c. When the message has been completely received, the outgoing multiple point unit sends a sequence signal out on the loop. This signal puts all stations back in a stand-by condition in preparation for transmission of traffic.

d. Multiple point operation is arranged so that high precedence traffic will interrupt messages of lower precedence. If a remote station on the multiple point loop desires to transmit a high precedence message while the line is occupied by a message of lower precedence, the station with the high precedence can send a signal to the switching center overriding the low precedence message. This signal causes a cancellation signal to be added to the low precedence message. The line then becomes available to the station desiring to transmit the high precedence message.

e. If transmission from the relay center to a remote station on the multiple point loop is required, the multiple point group is seized by a cross-office unit in the same manner as explained in previous examples. In this case, however, before the message is transmitted over the multiple point route, a selective sequence signal is sent over the loop. This signal causes only the proper station to set up its page printer to receive a message. A channel number sequence for the remote station being called is transmitted in accordance with the channel number register associated with that station.

f. It is possible that the relay center may need to transmit a selective sequence signal to control the incoming line while the outgoing line is busy because a station is transmitting a message. As a result of this selective sequence signal, extraneous characters could be inserted in the transmitted message. However, the AN/FGC-30 has been so engineered that it can use individual characters of the message, coded in a tuned sequence, as the selective sequence signal. This ensures that no extraneous characters will be inserted in any message as a result of a selective sequence signal.

Section IV. AUTOMATIC SWITCHING CENTERS, US NAVY

18. GENERAL

a. In October 1958, the US Navy cut over the first of its five fully automatic switching centers. This first center is located at Trenton, New Jersey (RUEG) and uses equipment designed by the Bell Telephone Laboratories. The system is known as the 82B1.

b. On 5 May 1959, the Navy cut over four additional centers: Norfolk, Virginia; Cheltenham, Maryland; Stockton, California; and San Diego, California. With these additional centers, 236 tributary stations in 31 states are connected in a fully automatic 48,000-mile network. This network, together with a 5,000-mile network of 85 semi-automatic stations, makes up the Naval Teletypewriter Network (NTX).

19. FEATURES OF THE 82B1

Some features of the 82B1 system are --

a. Fully Automatic Operation. The system is fully automatic. It receives incoming messages and routes them without manual intervention to suitable outgoing lines. Manual processing is required only when improperly prepared traffic prevents handling by the equipment or when traffic is addressed to supervisory personnel.

b. Compatibility. The 82B1 is fully compatible with the equipment employed in the Strategic Army Communications System (STARCOM), the USAF Air Communications Network (AIRCOMNET), and the USAF Air Operations Network (AIROPNET). Traffic may be interchanged with automatic equipment of the other service networks without modifications.

c. Routing Indicator Plan. The current routing indicator plan in ACP 121, Communications Instructions, General, is recognized by this system. Routing indicators can be reassigned within the system as changes occur in the plan.

d. Three-Speed Operation. The system can receive and transmit messages at any of the three standard speeds of 60, 75, or 100 words per minute, and can use all three speeds at once. However, 60 and 100 words per minute are currently being used.

e. Cross-Office Speed. The system can transmit messages cross-office at a speed of 200 words per minute. This speed was selected to reduce to an absolute minimum the time required for relaying a message through the switching center. Since the cross-office speed of transmission is equal to at least twice the incoming line speed, the equipment is arranged so that it takes no switching action until it has received a completed message. In the case of high precedence traffic, however, the cross-office path is established while the message is being received.

f. Precedence. This equipment recognizes two grades of military precedence: regular traffic (PRIORITY, ROUTINE) and high precedence traffic (FLASH, IMMEDIATE). High precedence traffic gets preferential handling, but does not interrupt transmission of low precedence traffic.

g. Continuity of Traffic. The system automatically checks the transmission identification (channel number sequence) of a message. When the number comparator recognizes a break in the channel number sequence, an alarm is activated and an operator takes the required action.

h. Message Control. Continuity of traffic is protected throughout the system by a complete alarm system to warn supervisors, operators and maintenance men of improper functioning of the equipment or of improperly prepared incoming message tapes.

i. Intercept Position. When messages are improperly prepared, contain garbled or unrecognizable characters in the routing line, or contain nonvalid routing indicators, the system automatically directs them to intercept positions. Operators may direct messages manually to intercept positions, where the messages may be examined and the necessary supervisory action taken. Visual and audible alarms announce when a message is sent to an intercept position. This type of intercept position is known as miscellaneous intercept. The system also provides intentional intercept positions. Messages are intentionally intercepted when a station is not in service during certain periods, such as weekends or holidays; when it is temporarily released for routine maintenance; or when it is unable to receive traffic due to line or machine trouble. Until manually set for automatic direction, the equipment does not automatically direct messages to intentional intercept positions. There are no audible or visual alarms associated with intentional intercept positions.

j. Operator Service Position. To transmit service messages, reruns and corrected messages, and to reintroduce messages into the system, operator service positions are provided. These positions are like the manual forwarding positions of the AN/FGC-30. The operator service position has three basic functions: tape preparation, message servicing, and insertion of messages into the system.

k. Multiple Call Message. This system handles multiple call messages automatically. There is no limit to the number of routing indicators which may be processed in each message.

l. Multiple Point Operation. The 82B1 provides multiple point operation (multiple station line) on a full-duplex basis. It is possible for one station on line to receive traffic while a second station is transmitting. The switching center exercises control over transmission and reception. No more than five stations may be served on one multiple station line.

m. Other Features. Other features of this equipment are --

- (1) The switching center consists primarily of self-contained units of equipment known as the incoming cabinet and the outgoing cabinet.

- (2) This equipment handles single or multiple call messages with equal speed.
- (3) A message is transmitted cross-office only once, regardless of the number of address and/or outgoing lines to which it must be routed.
- (4) Specially trained Bell Telephone Company personnel maintain the equipment. Switching center personnel are responsible for simple maintenance operations, such as replenishing paper and tape rolls, replacing teletypewriter ribbons, and removing tape and paper from storage reels.

20. SYSTEM OPERATION

Basically the switching center consists of the incoming cabinet and the outgoing cabinet (fig. 11). Each incoming cabinet contains two incoming line units with associated reperforator-transmitters. In each incoming cabinet there is one director circuit and its associated reperforator-transmitter. Thus, one director circuit serves two incoming line units. On all precedence messages, the director circuit alternates between the two incoming line units to serve them equally. That is, the director circuit works with a message on one incoming line only long enough to act upon the information contained in the heading and establish the cross-office path for that message. It then switches to serve the second incoming line unit in a similar manner, "flip-flopping" between the two incoming line units. On high precedence traffic, however, the director circuit may not alternately serve the two incoming line units. Instead, as soon as it is available, it serves that incoming line unit which holds the high precedence message. If high precedence messages are present on both incoming lines, then the director circuit alternates equally between both incoming lines. Preferential treatment is given only on the basis of high precedence (FLASH, IMMEDIATE) and regular traffic (PRIORITY, ROUTINE).

a. Capabilities of the Incoming Cabinet.

- (1) Each incoming cabinet terminates two incoming lines, one of which may be a multi-station line; however, both incoming lines may be single station lines.
- (2) The incoming cabinet perforates and types incoming messages on a reperforator-transmitter unit.
- (3) It is capable of distinguishing between high and low precedence messages -- or operational and administrative messages, according to the terminology often used with this equipment.
- (4) Through the action of its director circuit, each incoming cabinet automatically establishes a cross-office path to the outgoing cabinet, checking the continuity of each path and verifying operation of the outgoing cabinet machine.
- (5) It establishes the cross-office path on a preferential basis for high precedence messages and in approximate order of receipt for low precedence messages.
- (6) It checks channel numbers on incoming messages for continuity of traffic.
- (7) It transmits messages cross-office to outgoing cabinets.
- (8) It disconnects the cross-office path at the end of a message.
- (9) It checks the routing indicator line for nonvalid routing indicators. When this check reveals a nonvalid or garbled routing indicator it automatically sends the message to an intercept position.

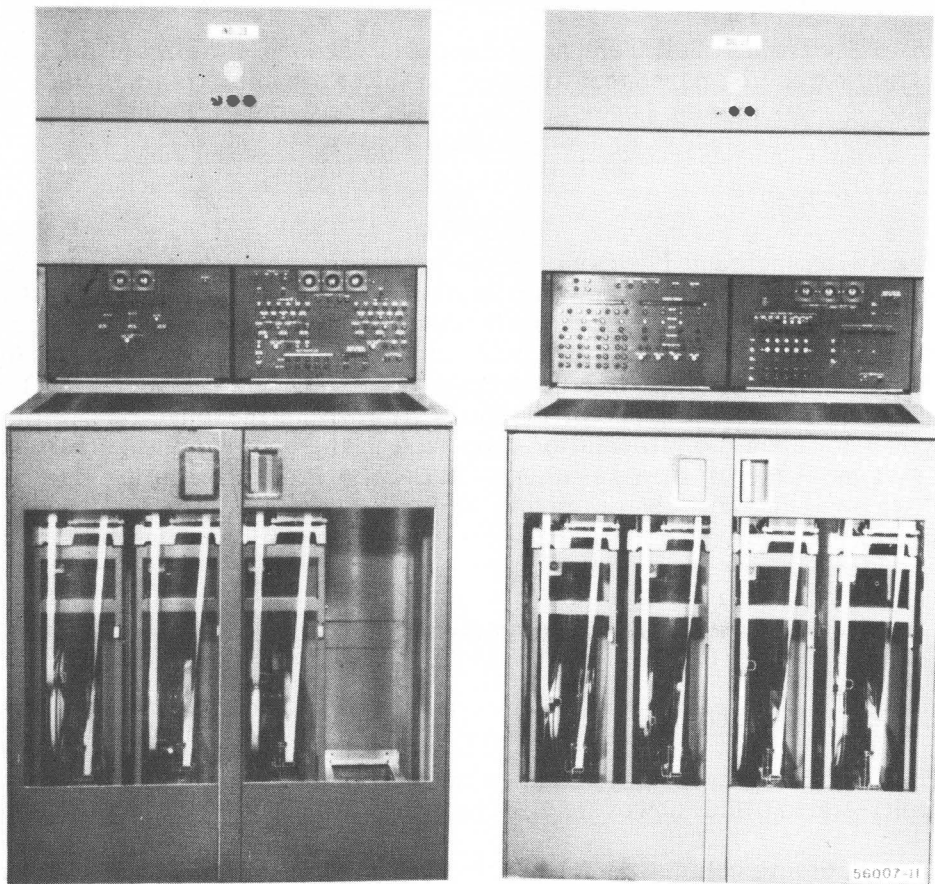

Figure 11. The 82B1: incoming (left) and outgoing cabinets.

- (10) It provides visual and audible indications of both irregularities in message format and of equipment malfunctions.

b. Capabilities of the Outgoing Cabinet.

- (1) Operating in conjunction with the director circuit of the incoming cabinet, each outgoing cabinet completes and verifies the establishment of a cross-office path.
- (2) It verifies operation of the outgoing equipment selected.
- (3) It provides for high and low precedence message handling.
- (4) It automatically selects and connects idle reperforator-transmitter machines to receive messages from the incoming cabinet.
- (5) It automatically generates and transmits outgoing channel numbers to the outgoing line.

- (6) Where the number of outgoing machines exceeds the number of outgoing lines, it selects and connects idle lines to outgoing machines which have messages for transmission.
- (7) On multi-station lines the outgoing cabinet automatically polls the multi-point tributary stations for traffic.
- (8) It provides visual and audible indications for proper supervision of the flow of traffic.

21. SIMPLIFIED PROCESSING

The following is a simplified explanation of the operation of the 82B1 in processing a single address message of regular precedence.

a. As the message arrives at the switching center, the SOM (VZCZC) indicates the start of the message. The number comparator is called into action and compares the channel number group of the message with the number in the comparator register. The channel number (see figure 4) consists of eight characters: three letters to identify the station and the channel over which the incoming message is being received, followed by a FIGURES shift and three numerals to identify the serial number of the transmission, followed by a LETTERS shift.

b. If the number sequence in the register of the channel number comparator does not agree with the channel number of the message, then a red lamp alarm is activated at the incoming cabinet. The director circuit will be held up and unable to operate until this alarm has been cleared by operating personnel. If the number in the register of the channel number comparator and the channel number on the message agree, the director is permitted to operate.

c. Immediately after a channel number sequence, the tape will show two carriage returns, one line feed, a precedence designation (PP or RR and a space). This precedence recognition sequence conditions the equipment for either regular handling or preferential handling of high precedence traffic. It also indicates which incoming line unit the director will serve.

d. The director stores this precedence sequence and continues on to record the routing indicators on the message tape. It then stores the routing indicators and translates them into a designation of an outgoing line. When the director reaches the end of the routing line it recognizes this fact by sensing the characters, two carriage returns, a line feed, and D or Z. This now indicates that routing information is complete and cross-office switching may begin. Having analyzed and stored this information, the director circuit indicates to the sequence circuit in the incoming cabinet that the director is ready to establish a cross-office path or paths.

e. The sequence circuit acts on the bids of all director circuits in the switching center in such a manner that requests for cross-office paths are handled in the approximate order of their receipt. The sequence circuit having established the cross-office path, the director circuit then sends a request to the bid receiver circuit of the proper outgoing cabinet. The bid receiver acts upon this request from the director by selecting and connecting an idle machine to receive the cross-office transmission. The bid receiver circuit connects a specific channel-number generator to the outgoing line. It then indicates to the director circuit that the proper outgoing machine has been connected.

NOTE: The machine selected to receive the cross-office transmission will be either a regular or a high precedence machine depending on the precedence of the message. High precedence machines are given preference for transmission over the outgoing line. When a high precedence machine is available, it is connected automatically. The message is then permitted to be transmitted cross-office. Having received an acknowledgement by the director circuit for cross-office transmis-

**BLOCK DIAGRAM
82B1 TELETYPEWRITER
SWITCHING SYSTEM**

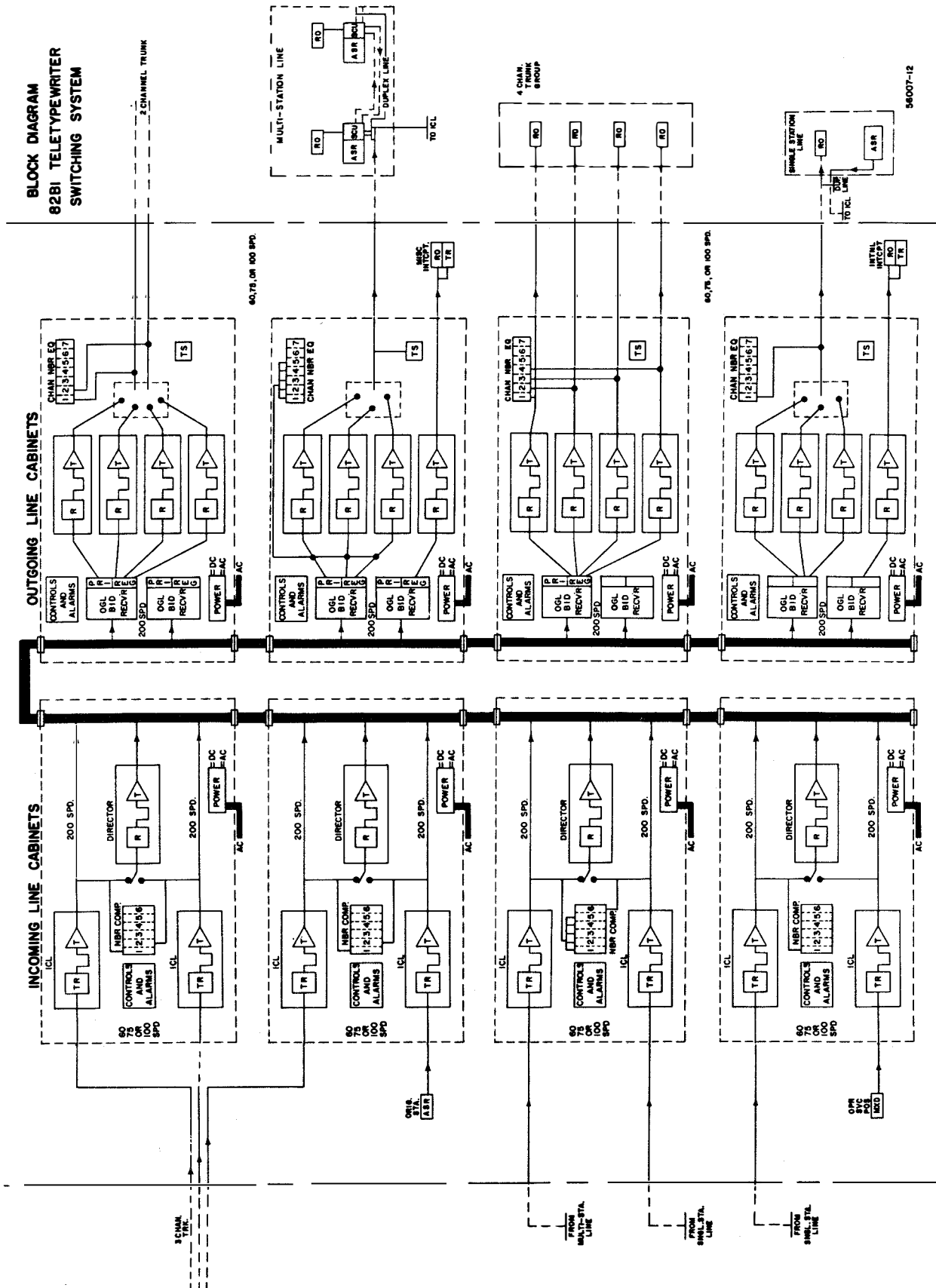

Figure 12. The 82B1: block diagram.

sion, the transmitter of the incoming line unit transmits the message over the cross-office path which has been established. The director then becomes available to serve the alternate incoming line unit. When the end of message indicator (EOM), which consists of the characters, line feed and 4 N's, passes through the system, it progressively causes the release of all equipment which had been seized for the message. Figure 12 shows a block diagram of the teletypewriter switching system.

Section V. AUTOMATIC SWITCHING CENTERS, US AIR FORCE

22. GENERAL

a. Since February 1951, the US Air Force has operated a 200,000-mile private wire network (USAF AIRCOMNET). Originally, this network included five Plan 51 switching centers leased from Western Union. They have since been replaced with fully automatic switching centers known as the Plan 55.

b. The "Gateway" centers to the Atlantic and to the Pacific are located at Andrews AFB, Maryland, and McClellan AFB, California. These Gateway centers, as well as other continental USAF centers, employ the Plan 55. Plan 55 equipment has also been installed at some bases overseas.

23. FEATURES OF PLAN 55

Some features of the USAF Plan 55 system are --

a. Fully Automatic Operation. The equipment is fully automatic. It receives incoming messages and routes them without manual intervention to proper outgoing lines. Manual processing is required only where improperly prepared messages preclude handling by the equipment or when messages are addressed to supervisory personnel.

b. Single Installation in Network. The equipment can be installed at any point within a tape relay network; it does not require similar equipment to be located at other points.

c. Compatibility. The equipment permits interchange with the automatic equipment of US Navy and US Army centers, without modifications.

d. Routing Indicator Plan. The current routing indicator plan in ACP 121, Communications Instructions, General, is recognized by this system. Routing indicators can be reassigned within the system as changes occur in the plan.

e. Line Speeds. Messages may be received and transmitted at speeds of 60, 75, or 100 words per minute. All three standard speeds may be used simultaneously.

f. Cross-Office Speed. Messages are switched cross office at a speed of 200 words per minute.

g. Push-Button Switching. Maximum flexibility is provided by push-button panels which permit manual, semi-automatic switching when required because of improperly prepared or garbled messages, emergency setup of small centers, and similar factors.

h. Precedence. The equipment recognizes and handles traffic of either high or low precedence. Switches are provided on the back of each director console to permit the precedence pro-signs, O or R, to be recognized as either high or low precedence. Z is always read as high precedence and R is always read as low precedence. Normally these switches are set to read Z, O and P as high precedence, and R as low precedence. High precedence messages are given preferential handling.

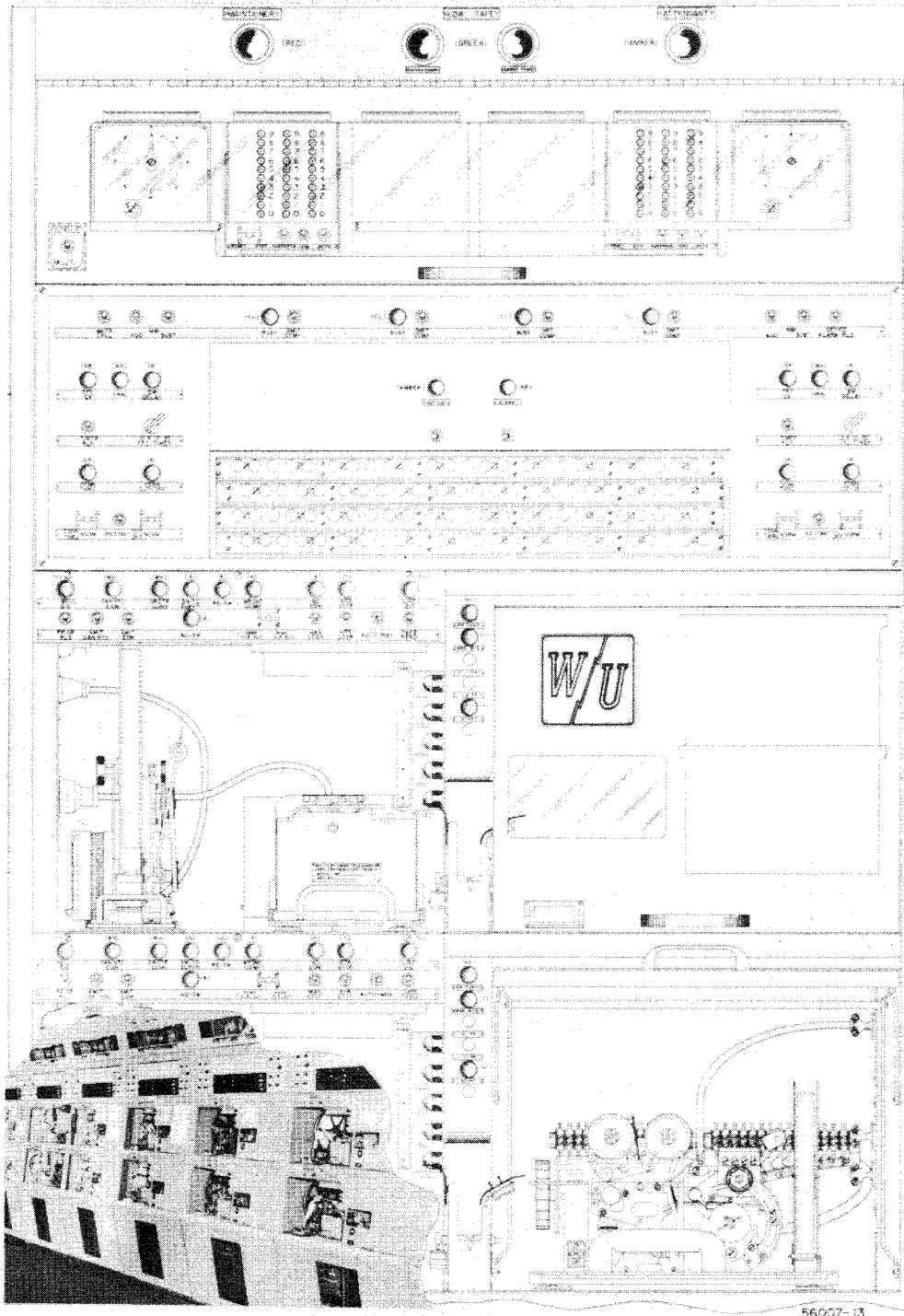

Figure 13. Plan 55: incoming consoles.

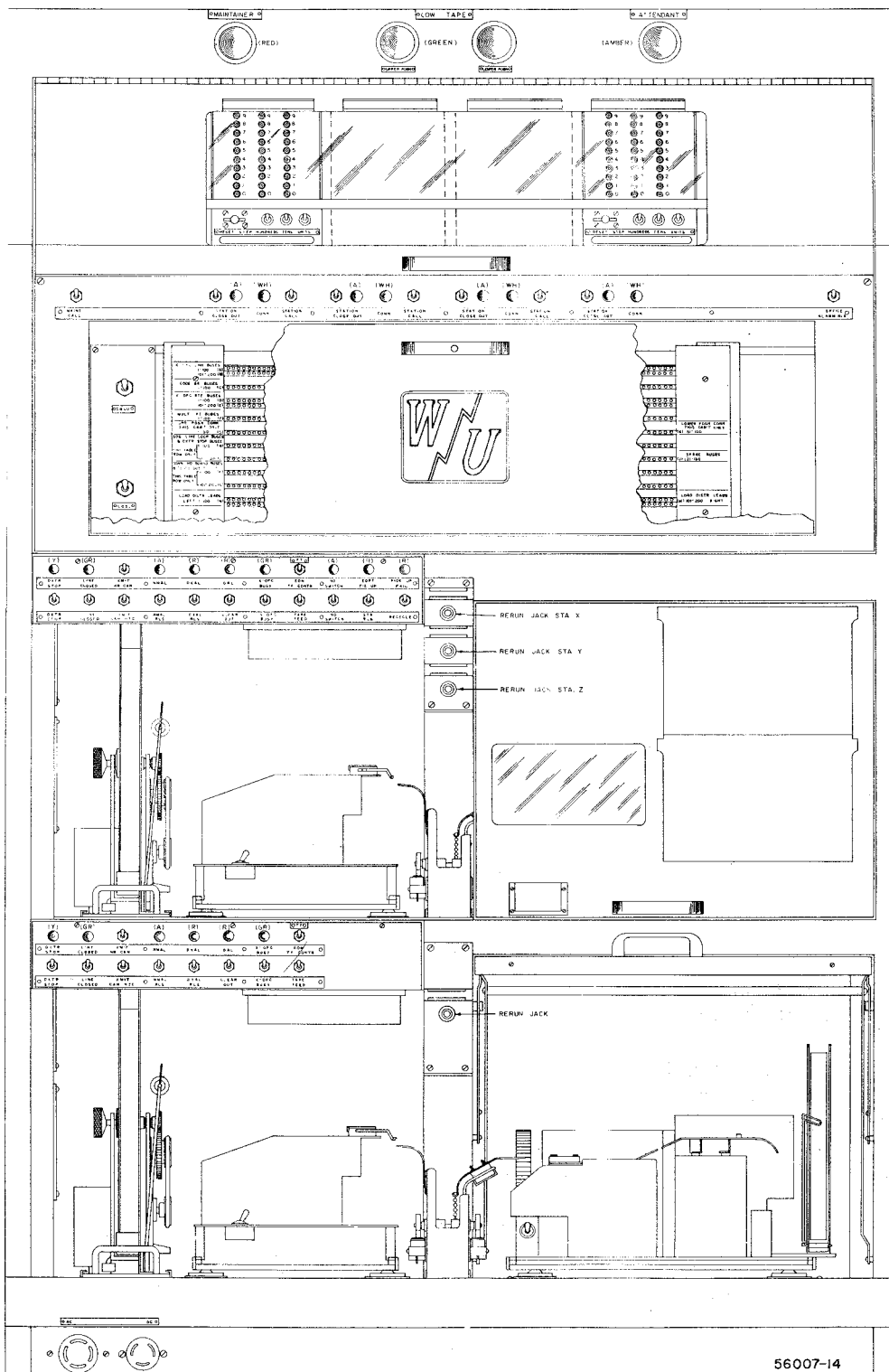

Figure 14. Plan 55: outgoing consoles.

i. Continuity of Traffic. A sequence number indicator (SNI) automatically checks the channel number sequence at the incoming line. Automatic message-numbering machines transmit channel numbers on the outgoing line, ahead of each message.

j. Message Control. The equipment has a complete alarm system to warn supervisory and maintenance personnel of any improper functioning of the equipment and improperly prepared incoming message tapes.

k. Electronic Cross-Office Transmission. Signals are transmitted cross office electronically over a single conductor. This reduces the number of cable conductors, multiconductor plugs, sockets and switches required.

l. Multiple call Messages. Multiple call messages are handled on a routing line segregation basis. The number of routing indicators which may be processed in any one message is limited to nine. Transmission cross office is limited to only four cross-office routes to outgoing line consoles. Where more than four routes are required, the fourth route is to a multiple address spillover position (MC-SPO). This tape contains all unprotected stations. It is transmitted from the outgoing line console MC-SPO back into a similar MC-SPO position at the incoming line console. The tape again processes cross office in a similar manner until all stations have been protected.

m. Other Features.

(1) Plan 55 centers have facilities to accommodate up to 200 circuits and 100 destinations. The system can be expanded up to 400 circuits and 200 destinations.

(2) The switching center includes --

Groups of identical, self-contained incoming line consoles (fig. 13, pg 26).

Groups of identical, self-contained outgoing line consoles (fig. 14, pg 27).

Automatic switching directors.

Local transmitting and receiving positions.

A traffic control center (fig. 15, pg 29).

Portable retransmission carts to handle rerun requests.

(3) Multipoint operation (multi-station circuits or "way wires") is possible with two or three tributary stations per circuit on a full-duplex basis.

24. SYSTEM OPERATION

a. A model 28 reperforator recognizes or senses the SOM (VZCZC) and causes the message waiting indicator (MWI) to be activated (f below).

b. A 200-wpm incoming line transmitter also recognizes or senses the SOM and causes the sequence number indicator (SNI) to be connected. The SNI compares the incoming channel number with the number in its register. The number in the SNI is indicated in digit form by three neon lamps on the SNI. Any variation in the channel number sequence activates an alarm to alert the operator to take whatever action is required.

b. If the channel numbers agree, the 200-wpm transmitter then reads the line feed (LF) which appears at the end of the channel-number line. This connects the automatic switching director (fig. 16, pg 30) and puts the sliding loop gate of the TD into the lefthand position. In this position, the tape is not permitted to pass completely through the TD which permits the information contained after the LF, the routing indicators, and the precedence designations to be processed through the automatic switching director. As the routing line is fed through the 200-wpm TD a loop is formed (fig. 17, pg 31).

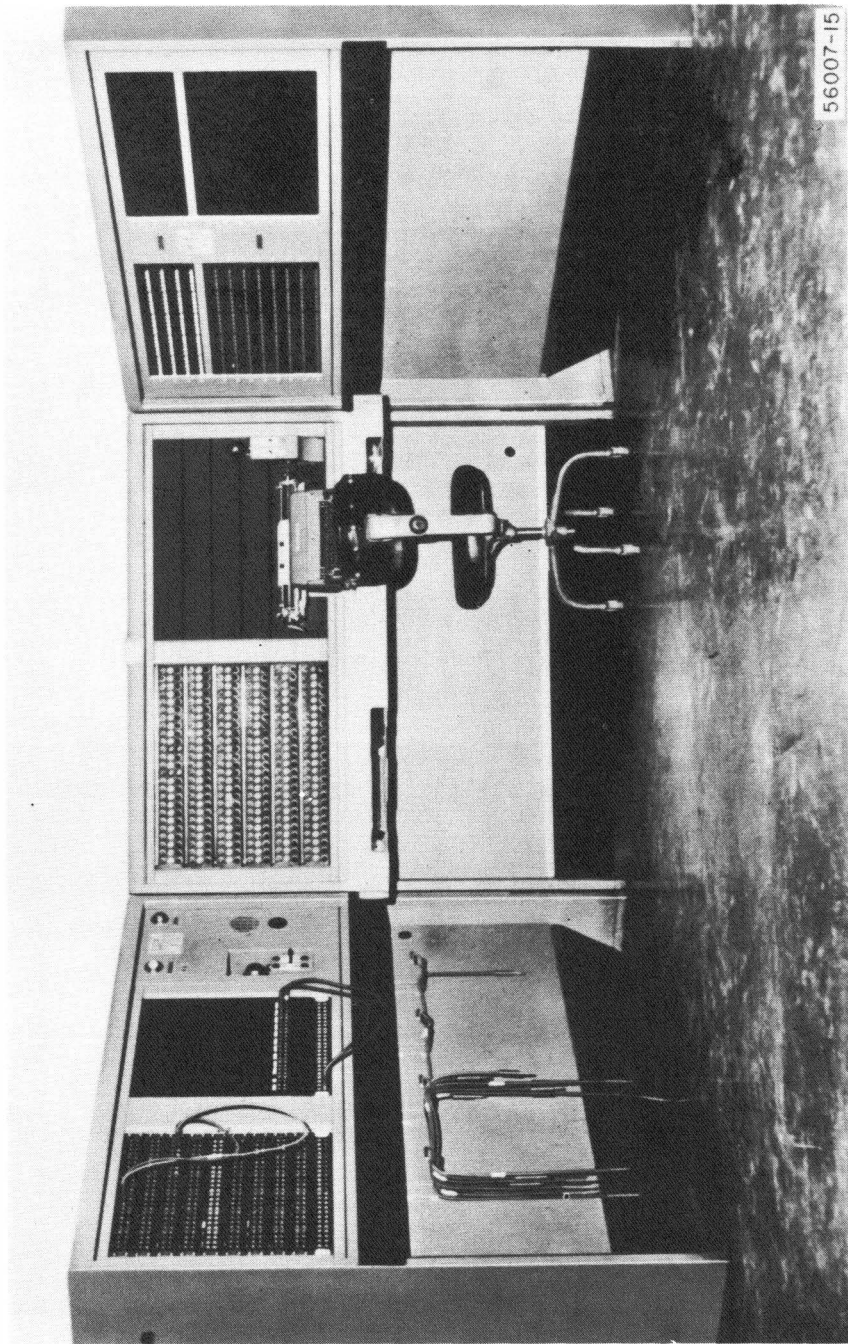

Figure 15. Plan 55: traffic control center.

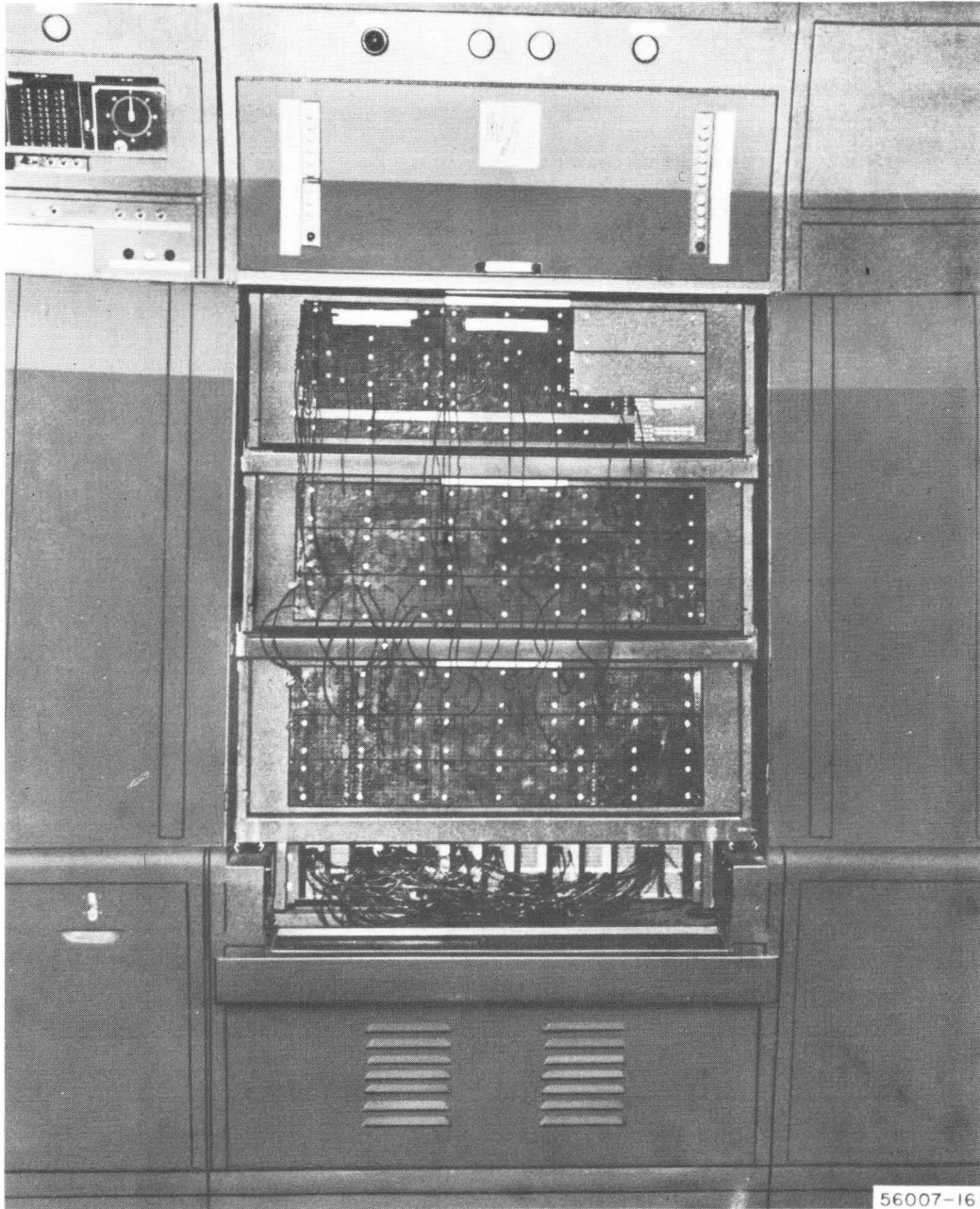

Figure 16. Plan 55: automatic switching director.

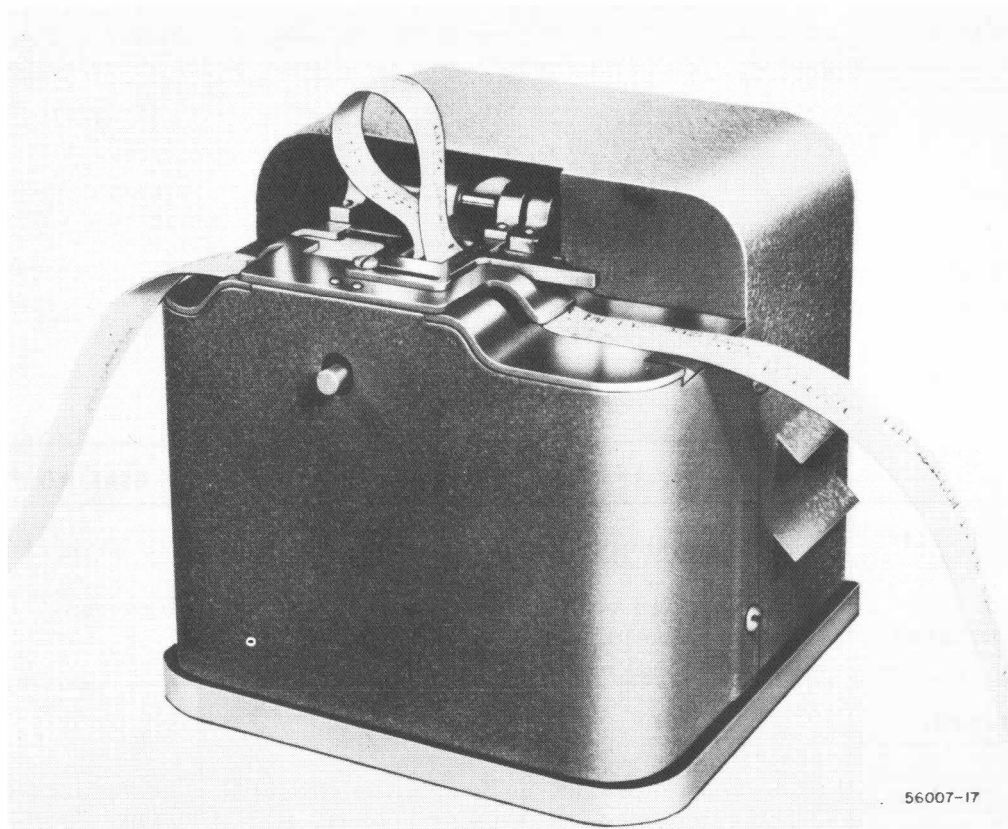

Figure 17. Plan 55: 200-wpm TD, showing paper loops.

c. Each routing indicator in the routing line is preceded by a space (SP). When the 200-wpm TD reads an SP, it starts the automatic switching director which, in turn, processes a routing indicator.

d. The switching director, through the services of a translator, receives a translation of routing indicators to outgoing lines. The automatic switching director then sets up the proper cross-office path in accordance with the translations and as high or low precedence.

e. After the routing indicators are processed, the machine functions 2CR LF and a letter D or Z are then sensed. The machine functions indicate that no additional routing indicators are to be processed and disconnects the automatic switching director. Simultaneously, the sliding loop gate on the 200-wpm TD is set to its righthand position which prepares the TD for transmission over the cross-office path set up by the automatic switching director.

f. As the message goes through the incoming line reperforator, the EOM (LF NNNN) is recognized and causes the message waiting indicator to advance to the next number. The main function of the MWI is to control cross-office transmission. When the MWI is on "0", cross-office transmission cannot be made (except high precedence through the use of the bell signal). Cross-office transmission can be made only when the MWI is on a number. Since the MWI does not advance to a number until the EOM is sensed, only a complete tape with the proper EOM is permitted to be transmitted cross office.

g. As the message is transmitted cross office through the 200-wpm TD, the EOM is sensed in this TD. This disconnects the cross-office path, subtracts "1" from the MWI and advances the SNI to the next number.

h. The message, after cross-office transmission, is sent out on the proper outgoing line of the outgoing console. An automatic numbering machine sends an SOM and channel number at the beginning of each message. As the EOM is sensed, the outgoing console is disconnected and transmission is complete.

APPENDIX I
SUMMARY CHART

	AN/FGC-30	USN Bell 82B1	USAF WU Plan 55
Incoming Line Speed	60, 75 or 100 wpm.	60, 75 or 100 wpm.	60, 75 or 100 wpm.
Cross-Office Speed	75, 110 or 115 wpm (depending on incoming line speed).	200 wpm.	200 wpm.
Fully Automatic	Yes.	Yes.	Yes.
Precedence Handling	Acts on all 4 precedence categories.	Recognizes HIGH (Z, O) or LOW (P, R).	Recognizes HIGH and LOW. Switches allow setting of O or P, to be HIGH or LOW as desired. Z is always HIGH, R is always LOW.
Routing Indicator Line Limit	No limit.	No limit.	Only 9 routing indicators allowed per message.
Compatible with Other Automatic Equipment	Yes.	Yes.	Yes.
SOM	VZCZC	VZCZC	VZCZC
EOM	3LF NNNN	LF NNNN	LF NNNN