

# **CWR6850**

**TELEREADER**

# **INSTRUCTION MANUAL**



**HAL COMMUNICATIONS CORP.  
BOX 365  
URBANA, ILLINOIS 61801**

*QUALITY COMMUNICATIONS EQUIPMENT*

C W R 6 8 5 0  
T E L E R E A D E R

PORTABLE  
RTTY/CW TERMINAL

Copyright © 1981 by HAL Communications Corp., Urbana, Illinois.  
Printed in the United States of America. All rights reserved.  
Contents of this publication may not be reproduced in any form without  
the written permission of the copyright owner.

April, 1982 Printing

## CWR6850 TELEREADER

### CONTENTS:

INTRODUCTION . . . . .	1
CHAPTER 1. UNPACKING AND INSPECTION . . . . .	3
CHAPTER 2. SIMPLE HOOK-UP AND OPERATION . . . . .	5
2.1 Connections to the CWR6850 . . . . .	5
2.2 Presetting CWR6850 Controls . . . . .	6
2.3 Presetting the Transceiver Controls . . . . .	7
2.4 RTTY Operation . . . . .	8
2.5 Morse Operation . . . . .	9
CHAPTER 3. RECEIVING WITH THE CWR6850 . . . . .	10
3.1 Connecting the CWR6850 to Your Receiver . . . . .	10
3.2 Receiving RTTY Signals . . . . .	11
3.3 Low Tones or High Tones? . . . . .	13
3.4 Receiving Morse Code . . . . .	16
CHAPTER 4. TRANSMITTING WITH THE CWR6850 . . . . .	20
4.1 The Keyboard . . . . .	20
4.2 Transmit Features . . . . .	21
4.3 Use of the HERE-IS Messages . . . . .	25
4.4 Special Considerations When Transmitting Morse . . . . .	28
4.5 Special Considerations When Transmitting Baudot . . . . .	30
4.6 Special Considerations When Transmitting ASCII . . . . .	34
4.7 HDX / FDX Operation . . . . .	37
4.8 The KOS Feature . . . . .	37
CHAPTER 5. CONNECTIONS TO THE CWR6850 . . . . .	40
5.1 Normal Amateur Station Connections . . . . .	40
5.2 Use of the TTL Data Connections . . . . .	42
5.3 Use of the SW-OUT FSK Connection . . . . .	43
5.4 Use of a Different Keyboard . . . . .	43
5.5 Connection of an ASCII Printer . . . . .	43
5.6 Connection of an Audio Tape Recorder . . . . .	44
5.7 RTTY Tuning Oscilloscope Connections . . . . .	45
5.8 Using a Television Set as a Monitor . . . . .	46
5.9 RF-Induced Problems . . . . .	48

CONTENTS:

CHAPTER 6.	IN CASE OF DIFFICULTY . . . . .	54
6.1	Care and Feeding of Your CWR6850 . . . . .	54
6.2	Typical Operational Problems . . . . .	56
6.3	Repair Procedures . . . . .	57
6.4	User Adjustments . . . . .	59
CHAPTER 7.	SPECIFICATIONS . . . . .	63
APPENDIX A:	CWR6850 KEYBOARD CONTROL COMMAND LIST . . . . .	68
APPENDIX B:	CWR6850 DISPLAY FORMAT . . . . .	70
	LIMITED WARRANTY . . . . .	73
ADDENDUM 1:	. . . . .	75

ILLUSTRATIONS:

Figure 1.	The CWR6850 . . . . .	2
Figure 2.	Simplified CWR6850 Connections . . . . .	4
Figure 3.	The CWR6850 Keyboard . . . . .	19
Figure 4.	Connections to the CWR6850 . . . . .	39
Figure 5.	KOS Circuit Connections . . . . .	41
Figure 6.	Typical Video Detector . . . . .	47
Figure 7.	Modified Video Dectector . . . . .	47
Figure 8.	RFI Reduction Techniques . . . . .	49
Figure 9.	RFI Power Line Filters . . . . .	51
Figure 10.	Test Points and User-adjustable Controls . . . . .	60

TABLES:

TABLE 1.	CONTINENTAL MORSE CODE . . . . .	29
TABLE 2.	BAUDOT DATA CODE . . . . .	32
TABLE 3.	DISPLAY SYMBOLS FOR THE ASCII CODE . . . . .	35
TABLE 4.	ASCII DATA CODE . . . . .	36

## CWR6850 USER MANUAL

### INTRODUCTION

This manual describes the installation and operation of the HAL CWR6850 Telereader Portable RTTY/CW Terminal. The technical details with schematic diagrams are described in a second publication, the CWR6850 Customer Maintenance Manual, available separately from HAL Communications Corp. or its designated dealers and representatives.

The features of the CWR6850 have been designed for convenient and straightforward customer use; many features are self-explanatory from a close examination of the CWR6850 front panel, rear panel, screen display, or the keytops. However, like many sophisticated electronic devices, there are some features and operator techniques which you may not understand until you have read this manual. You should plan to devote several hours to becoming familiar with your CWR6850.

However, there are many hobbyists, including this writer, who are eager to try the new "gadget" and lack the patience to plow through chapters of technical talk without at least turning it on and trying out something. Therefore, for the eager and impatient new owners, we offer Chapter 2 - SIMPLE HOOK-UP AND OPERATION. After you have your CWR6850 running as described in Chapter 2, please then sit down and read the rest of this manual; you'll find the CWR6850 will do a lot more things than can be outlined in the simplified instructions.

Please note the contents of APPENDIX A and APPENDIX B in particular. You will probably refer to these pages often as you study this manual.



Figure 1 The CWR6850

## CHAPTER 1

## UNPACKING AND INSPECTION

When you unpack your CWR6850, carefully inspect the shipping carton and each cabinet for shipping damage. Any evidence of shipping damage should be immediately reported to your supplying dealer or shipping carrier. Be sure to save all packing materials if damage is found - the shipping carrier will want to inspect them for any insurance claim. Before discarding the packing materials check that all parts and accessories are accounted for. Check the accessories against the following list. If any are found missing, double-check the packing for loose parts and then notify either your dealer or HAL Communications Corp. of the shortage. Please specify the HAL part number!

## Accessory parts:

## Accessories Packed With CWR6850:

- 1 - 333-10000 DC Power Cord
- 4 - 310-35012 Phono Pin Plug
- 1 - 770-20009 2 Ampere fuse
- 1 - 333-00030 Mini-phone Plug
- 1 - 870-06850 CWR6850 USER MANUAL

In addition to the furnished accessories listed above, you may wish to purchase the mating printer connector, HAL No. 332-12000, for \$10.00 each.

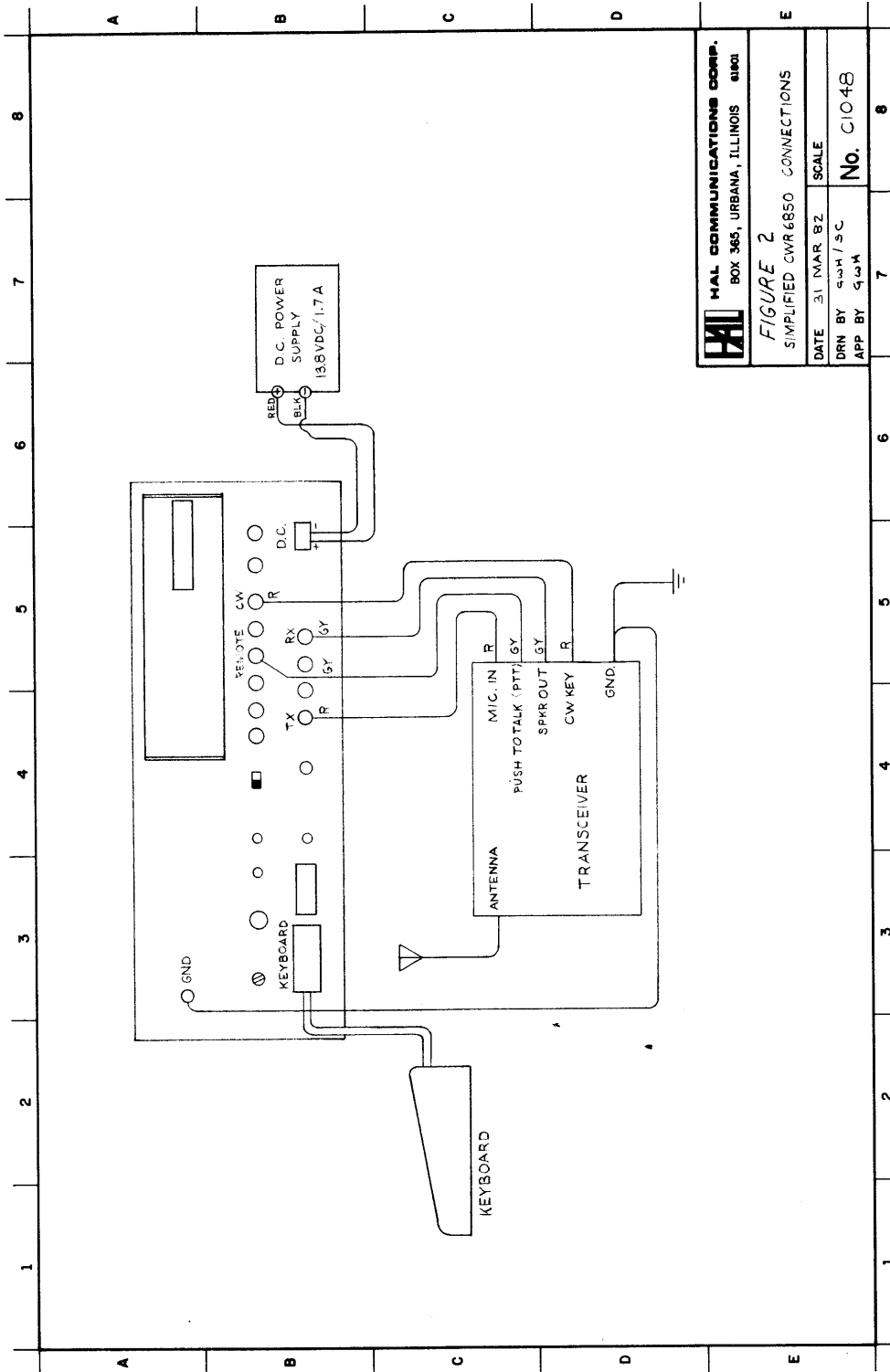

**HAI** HAL COMMUNICATIONS CORP.  
 BOX 365, URBANA, ILLINOIS 61801

**FIGURE 2**  
 SIMPLIFIED CWR 6850 CONNECTIONS

DATE 31 MAR 82 SCALE

DRN BY cwh/sc

APP BY gwh

No. C104B

Figure 2. Simplified CWR6850 Connections



## CHAPTER 2

## SIMPLE HOOK-UP AND OPERATION

Although there are many features of the CWR6850 explained in this manual, you may wish to first "plug-it-in" and "try-it-out" without reading the whole book. This section of the manual presents enough information to start using the CWR6850, but you will eventually need to read Chapters 3, 4, and 5 to take full advantage of the many conveniences included in your CWR6850.

## 2.1 Connections to the CWR6850

Refer to Figure 2 and notice the various connections you may make to and from the CWR6850. For a start, it is recommended that you make the following connections at the present and leave the other connections until after you have read Chapters 3, 4, and 5.

1. Connect a good ground wire (1/4" shield braid preferred) between the CWR6850 cabinet, transceiver cabinet, and all other station equipment cabinets.
2. Connect a shielded audio cable between the receiver speaker (audio) output and the CWR6850 AF IN - RX connector.
3. Connect a shielded audio cable between the transmitter microphone audio input and the CWR6850 AFSK OUT - TX connector. Check your transmitter manual - some transmitters have +12 VDC on the mike input lead to run remote controls; use a 1 uF blocking capacitor at the mike connector to prevent damage to such a transmitter.
4. Connect a shielded audio cable between the transmitter push-to-talk input and the CWR6850 SW.OUT - REMOTE connector. (Steps 3 and 4 may be combined in a 2 conductor "stereo" cable with the transmitter end connected to a microphone connector; these steps are only necessary if you intend to transmit during these preliminary tests).
5. Connect the keyboard to the CWR6850.
6. Connect the CWR6850 DC Power cord to a source of well-filtered dc voltage between 12.0 and 14.5 volts. The CWR6850 draws approximately 1.6 Amperes; the battery or dc supply should be capable of supplying this current CONTINUOUSLY.

## \*\*\*\* CAUTION \*\*\*\*

Be sure that you connect the RED wire to the POSITIVE terminal and the BLACK wire to the NEGATIVE terminal of the power source. Serious damage may be caused to both the CWR6850 and the power supply if the proper polarity is not observed! Do not turn on the power at this time.

## 2.2 Presetting CWR6850 Controls

Before applying any power to the transceiver or the CWR6850, preset its switches as follows:

RESET ON	= Press and release
FILTER ON	= Off (button out)
SPACE / NARROW	= Off (button out)
CWID A / CWID B	= CWID B (button in)
DISPLAY: PAGE ON	= No action at present (button out)
MODE A/MODE B	= MODE A (button out)
CW / RTTY	= RTTY (button in)
ASCII / BAUDOT	= BAUDOT (button in)
LTR ON	= No action at present (button out)
FIG ON	= No action at present (button out)
LOCK - U.O.S. ON	= ON (button in)
NOR / REV	= NOR (button out)
BAUD	= 45.5 (left button in; others out)
SHIFT	= 170 (left button in; others out)
TONE	= LOW (right button in)
RX / TAPE	= RX (button out)
INPUT (slide control)	= 5 (mid-position)
VOLUME (slide control)	= 5 (mid-position)
SPEED (slide control)	= 5 (mid-position)
FINE (slide control)	= 0 (detent at mid-position)
SEND / AUTO / RECEIVE	= RECEIVE (lever down)
ON POWER	= ON (lever up)
FSK DEMOD (rear panel)	= INT
AFSK GAIN (rear panel)	= Maximum clockwise rotation
BRIGHT (rear panel)	= Maximuz clockwise rotation

After the cathode ray tube (CRT) has "warmed-up" you should see the following features on the screen:

1. Top portion of the screen blank except for a solid green square on the left side about 8 lines up from the bottom. This is the receive cursor and will indicate where the received text will be displayed.
2. Three rows of dots at the bottom of the screen. This is the "top portion" of the transmit buffer. Each dot represents one character position. Type a few characters and notice how they are displayed; erase them with the BS (Back Space) key.
3. A reverse video number "1" 4 lines up from the bottom of the display. The number "1" on the extreme right-hand side indicates the page number presently being viewed. The page

number (0 to 3) is always indicated in reverse video on the extreme right of the screen. Try pressing the DISPLAY - PAGE button on the CWR6850; The screen format will change and the reverse video character will change from "1" to "0". Each press of the PAGE button cycles the display between page 1 and page 0. Next, push the MODE A/MODE B button in (selecting MODE B) and try cycling the PAGE button several times. Now you can see all four pages of the display in sequence. The meaning of the different formats will be explained as we progress through receive and transmit applications of the CWR6850. After experimenting with the PAGE and MODE buttons, reset to MODE A (button out) and PAGE "1" on the screen. The screen and page format are explained in APPENDIX B.

4. A letter "P" appears on the same line as the reverse video page number. This letter is a status indicator, showing that the printer output has been turned on. You may turn the printer on and off by typing "CTRL-P" on the keyboard (press and hold CTRL key while pressing and releasing the "P" key - just like a SHIFT key on a typewriter). After experimenting with CTRL-P, set the printer back to the "ON" condition (letter "P" on screen). Special control features of the CWR6850 are indicated by appropriate letters placed on this line. These features will be explained in detail later in this manual; the commands are listed in APPENDIX A.

### 2.3 Presetting the Transceiver Controls

Preset your transceiver controls as follows:

FREQUENCY:	14.075 to 14.100
ANTENNA:	Antenna for above frequency range
MODE:	LSB (lower sideband) *
PASSBAND TUNING:	LSB
RECEIVER AGC:	ON - SLOW
RCVR SELECTIVITY:	2 kHz - voice bandwidth
RCVR RF GAIN:	Maximum
XMTR MIC. GAIN:	Minimum
XMTR VOX:	Off
POWER SWITCH:	On
RCVR AUDIO VOL:	Comfortable Level

\* Use RTTY on Drake TR7; LSB on all other transceivers

You should now be able to tune signals on the receiver and hear them either on the receiver speaker or through the internal speaker of the CWR6850. If you are using the internal CWR6850 speaker, use the INPUT control on the CWR6850 to control the volume.

## 2.4 RTTY Operation

Tune the receiver for a RTTY signal ("deedle-deedle" noise). RTTY tuning is shown by the MARK and SPACE LEDs on the CWR6850 front panel. Correct tuning is achieved when the MARK and SPACE LEDs flash alternately as the RTTY signal tone changes back and forth between mark and space signal conditions. As you tune past the RTTY signal, you will notice that first one light and then the other flashes on the signal; optimum tuning is the setting that causes both to flash. With some practice, this is very easy to do. When the receiver tuning is correctly set, you should start seeing understandable text on the screen. If not, check that all CWR6850 and transceiver settings are correct; then try the NOR/REV switch and various speeds and shifts.

To transmit RTTY, make sure that the XMIT AUDIO GAIN control (of the transmitter) is set to minimum, turn the transmitter on with either its TX ON control or use the CWR6850 SEND switch (lever up). Increase the XMIT AUDIO GAIN until some RF output is obtained, tune the transmitter if necessary, and set the XMIT AUDIO GAIN to the recommended power level for RTTY (see your transceiver manual). After tuning and adjusting, turn off the transmitter with the transmitter switch or switch the CWR6850 to RECEIVE (lever down). Type the text to be transmitted on the CWR6850 keyboard - it will be displayed on the bottom three lines of the screen (dotted line area). When you are ready to transmit, move the CWR6850 switch to AUTO (lever middle position) and type "CTRL-A" ("A" character appears on status line with the "P" character). The KOS (Keyboard Operated Switch) circuit of the CWR6850 will turn the transmitter on and the text will be transmitted. The transmitter will turn off automatically when all of the text has been transmitted; additional typing of text will turn the transmitter back on and the new text will then be transmitted (after a short delay to allow transmitter relays to switch). You may listen to the output RTTY tones through the CWR6850 sidetone monitor system, controlled with the VOLUME slide control. The transmit text may be stopped at any time by switching to RECEIVE or by typing "CTRL-A" again (or with "CTRL-X").

The transmit section of the CWR6850 is placed in "continuous mode" when it is first turned on; that is, characters are transmitted one-at-a-time, as they are typed. Word mode can also be used by first typing "CTRL-Y" ("Y" character appears on status line). Now, text is transmitted a word at a time, allowing you to back-up and correct spelling errors before they are transmitted. The last word typed is not released to be transmitted until after you have typed a space bar character. Word mode and other transmit features are discussed in detail in Chapter 4. Programming and use of the HERE IS and CWID memory features are discussed in section 4.3 of this manual.

## 2.5 Morse Operation

To use the CWR6850 for Morse code reception, change the CW / RTTY button to CW (button out). Leave the transceiver mode in LSB for the present and tune to a Morse code signal. When the receiver is correctly tuned, the audio beat note will be approximately 800 Hz and the CW LED on the CWR6850 front panel will flash in sync with the key-down condition of the signal. You may monitor the code as processed by the CWR6850 by adjusting the VOLUME slide control; the Morse decoding circuit drives the internal sidetone oscillator. Since the sidetone oscillator is set to approximately 800 Hz, you may compare its frequency to that of the received signal by adjusting the two slide controls, INPUT and VOLUME, and tuning the receiver until they match. The INPUT control adjusts the volume of the received signal and VOLUME adjusts the volume of the regenerated side-tone output. This technique gives a very accurate way of optimizing the tuning. You should now see a display of the received Morse code signal.

If the CW signal you are listening to is weak or if interference is strong, try using the CW filter in the receiver, if one is available. Most transceivers couple the mode switch to the filter selection, so you may have to switch now to CW MODE on the transceiver. When switching to CW from LSB mode, you will probably have to retune the receiver to maintain reception of the desired CW signal. Be sure that the CWR6850 switch is set to RECEIVE before switching to CW to avoid inadvertent operation of the transmitter. The CWR6850 itself has a narrow-bandwidth PLL (phase-lock-loop) filter that may be used in addition to that in the receiver. To use the CWR6850 PLL CW filter, push the FILTER ON button in. This filter considerably narrows the audio bandwidth of the CWR6850 (to approximately 80 Hz) and the CW detection circuitry will no longer "track" the frequency of a drifting Morse code signal. Use the PLL filter only when noise and interference are causing poor "copy". The CWR6850 SPACE NARROW button may be depressed to compensate for signals with incorrect letter and word spacing, reducing the space required between words for display of a space on the screen. This feature may cause interpretation errors in the display of Morse characters and should be used sparingly!

To transmit Morse code, connect a shielded cable between the CWR6850 SW.OUT - CW jack and the CW KEY connection on the transceiver. Now, select CW mode on the transceiver. Tune the transmitter and set the CW level to the desired transmitter power output. Now, transmit Morse code in the same manner as explained above for RTTY, using the SEND or AUTO switch positions and "CTRL-A or "CTRL-X" commands to turn the transmitted data on or off. The "CTRL-D" command may also be used when transmitting Morse code to give a 25% extension of the dash length, effectively decreasing the "weight" (and speed) of the transmitted signal. Set the CWID A/CWID B switch to "A" (button out) for CW identification.

Now that the basic operations of the CWR6850 have been explored, sit back and read the rest of this manual.

## CHAPTER 3

## RECEIVING WITH THE CWR6850

## 3.1 Connecting the CWR6850 to Your Receiver

Connecting the CWR6850 to your receiver can be extremely simple - just hook a cable between the receiver audio output (external speaker or phone patch output jacks) and the "AF IN - RX" connector on the CWR6850 rear panel. Most receivers can be connected with a standard "high-fidelity" phono-to-phono cable, available at all "HI-FI" shops (some receiver external speaker jacks may require an adapter, so check out your receiver before you buy the cable). Or, if you like to make cables, use the phono plugs supplied in the CWR6850 accessories. By all means, use shielded cables - this will reduce the chances of RFI from the linear when you start transmitting! The CWR6850 has been designed to work well directly from the low-impedance speaker output. Refer to Figure 2 in the previous chapter for these simple CWR6850 connections; full connections are found in Figure 5 in Chapter 5.

The CWR6850 includes its own monitor speaker so that you may continue to listen to the receiver output even if the receiver's internal speaker is disconnected when you connect the CWR6850. The left-hand vertical slide control (INPUT) on the front panel controls this monitor volume level. If you wish, an external speaker may also be connected to the "EXT SP" jack on the CWR6850 rear panel.

Even though we are just thinking about receiving at the present, this is a good time to put in a good ground between the receiver and CWR6850. Use a short, low-inductance wire, preferably a 1/4" or wider piece of shield braid. Make the ground lead as short as convenient, direct from the CWR6850 cabinet to the receiver (or transceiver) ground terminal. Again, this is most important for transmitter RFI protection, but it may also prevent receive RFI problems. By all means, if you are using an AC power supply, USE GROUNDING TYPE AC OUTLETS - or add a ground wire between the power supply cabinet and good water-pipe ground - this is a safety measure that does not replace the need for a good RF ground.

Finally, connect power to the receiver and CWR6850, and turn-on the power switches to each. Proper settings for the CWR6850 front panel switches will be discussed in the next section. You may also wish to refer to APPENDIX B at the rear of this manual for an explanation of the display page arrangement of the CWR6850.

## 3.2 Receiving RTTY Signals

As a first step, preset the CWR6850 front panel switches as follows:

RESET ON	=	Press and release
FILTER ON	=	Off (button out)
SPACE / NARROW	=	Off (button out)
CWID A / CWID B	=	CWID B (button in)
DISPLAY: PAGE ON	=	No action at present (button out)
MODE A/MODE B	=	MODE A (button out)
CW / RTTY	=	RTTY (button in)
ASCII / BAUDOT	=	BAUDOT (button in)
LTR ON	=	No action at present (button out)
FIG ON	=	No action at present (button out)
LOCK - UOS ON	=	ON (button in)
NOR / REV	=	NOR (normal; button out)
BAUD	=	45.5 (left button in; others out)
SHIFT	=	850 (right button in; others out)
TONE	=	LOW (right button in)
RX / TAPE	=	RX (button out)
INPUT (slide control)	=	5 (mid-position)
VOLUME (slide control)	=	5 (mid-position)
SPEED (slide control)	=	5 (mid-position)
FINE (slide control)	=	0 (detent at mid-position)
SEND / AUTO / RECEIVE	=	RECEIVE (lever down)
ON POWER	=	ON (lever up)
FSK DEMOD (rear panel)	=	INT
AFSK GAIN (rear panel)	=	Maximum clockwise rotation
BRIGHT (rear panel)	=	Maximum clockwise rotation

After the cathode ray tube (CRT) has "warmed-up" you should see the following features on the screen:

1. Blank upper section of screen except for receive cursor on left side approximately 8 lines up from bottom. The cursor is a solid green square, indicating the position at which received text will be first displayed.
2. Three rows of dots at the bottom of the screen representing part of the transmit buffer storage area. Transmit features are discussed in more detail in Chapter 4.
3. A reverse video number "1" in the lower right section of the screen, indicating display of page 1. Display pages will be discussed in greater detail in the following sections.
4. A letter "P" to the left of the reverse video page number. The "P" signifies that the printer output is enabled. Other status indicator letters will be displayed in this line as various options are invoked.

If all of these indicators are as described, your CWR6850 is functioning properly; if not, re-check your front panel switch settings.

Now, preset your receiver for the following conditions:

FREQUENCY:	14.075 to 14.100 MHz
ANTENNA:	Adequate to receive signals in above range
MODE:	LSB (lower sideband) *
PASSBAND TUNING:	LSB
AGC:	ON - SLOW
SELECTIVITY:	2 KHz - normal SSB voice bandwidth
RF GAIN:	Maximum
AUDIO GAIN:	Comfortable listening level - see following discussion.

\* Use RTTY on Drake TR7; LSB on all other transceivers

Turn up the volume control of the receiver for a comfortable listening level from the CWR6850 internal monitor speaker. Leave the receiver set for this volume and use the INPUT slide control for further speaker volume adjustments.

If your receiver has an internal crystal calibrator, turn it on and tune the receiver to it so that you get a 1 - 3 kHz audio beat note. If you do not have a crystal calibrator, tune the frequency until you get a beat note on a received carrier signal. There are two different types of tuning indicators you may use when tuning RTTY signals on the CWR6850:

1. The MARK and SPACE LEDs on the front panel
2. A crossed-ellipse indication on an external X-Y oscilloscope (connected to the OSCILLO - MARK and SPACE rear panel connectors)

We will experiment with the first technique at this time; the external scope can be tried at a later time (see Chapter 5).

Tune your receiver frequency and notice that, as the beat note frequency changes, the MARK and SPACE LEDs will alternately turn on as you tune through their filters. You will need to tune slowly and carefully since the mark and space filters differ in frequency by only 850 Hz. Note that the lower frequency audio tone (at 1275 Hz) turns on the MARK light; the higher frequency tone (2125 Hz) turns on the SPACE light. Therefore, a correctly tuned RTTY signal will be indicated by alternate flickering of the MARK and SPACE LEDs.



Next, turn-off the receiver calibrator (or tune away from the carrier) and select 170 shift (170 SHIFT button in). Tune the receiver while listening through the CWR6850 monitor speaker until you find a moderately strong amateur RTTY signal (identified by the characteristic "deedle-deedle" tones). With careful tuning you should be able to tune so that the MARK and SPACE light flicker alternately. You should now see understandable text on the screen. If you don't, try the NORM/REVERSE switch - if this corrects the reception, double check your receiver settings to be sure you really are receiving LSB and not USB. If this doesn't give you good "print", try increasing the CWR6850 speed, trying both NORM and REV polarities for each speed. If you still can't make sense out of the display, try the ASCII code at 110 baud, either polarity. If all the combinations of MODE, SPEED, and NORM/REV fail, tune to another station, you have probably tuned-in an encrypted signal! Tune around the 20 meter amateur band and get used to tuning-in RTTY signals. It's difficult at first, but becomes much easier with some practice!

If you have a general coverage receiver, you may now wish to try receiving short-wave press RTTY signals. Commercial press RTTY stations can often be found on frequencies around: 5.2 MHz, 5.4 MHz, 5.8 MHz, 6.8 MHz, 7.5 MHz, 7.8 MHz, 8.0 MHz, 9.0 MHz, 9.4 MHz, 9.8 MHz, 10.2 MHz, 10.5 MHz, 10.8 MHz, 11.1 MHz, 11.5 MHz, 12.2 MHz, 13.5 MHz, 14.5 MHz, 14.9 MHz, 15.5 MHz, 15.9 MHz, 16.2 MHz, 16.4 MHz, 17.3 MHz, 17.5 MHz, 18.2 MHz, 18.4 MHz, 18.7 MHz, and 19.0 to 20.5 MHz (plus others!). Commercial RTTY stations will operate with either 850 or 425 Hz shift and may have speeds of 45 (60 wpm), 50 (67 wpm), 57 (75 wpm), or 74 (100 wpm) baud, Baudot code. The signals may be of either signal polarity, so try both NORM and REV conditions. There may be a few commercial press stations operating at 110 baud ASCII, also. Tuning these commercial stations will require some patience due to the wide variety of shifts, speeds, and polarities used.

The receive non-overprint feature will automatically place characters on the next line of the screen if more than 32 characters are received between line feed characters. To further prevent overprint, the receive section ignores all received carriage return (CR) characters and always executes a carriage return and line feed (LF) whenever a LF character is received. A space may be displayed when the CR character only is received.

### 3.3 Low Tones or High Tones?

So far we have only used one of the two possible CWR6850 demodulator combinations. You may wish to switch to the RTTY "high-tone" option - push the HIGH/LOW button in. The "high tones" (for higher-frequency audio tones) are really the traditional standard U.S. RTTY tones, used since the early days of amateur RTTY. The "low tones" are the IARU international standard and are used extensively in most other

countries of the world. When receiving (or transmitting) on the HF bands (3-30 MHz), either set of tones will work since you tune the receiver to produce the desired beat note frequency. However, when AFSK modulation is added to an FM or AM signal, you must be prepared to receive the same tone frequencies as those used by the transmitting station (the AM or FM receiver does not use a BFO to produce the audio tone). In the United States, the long-standing VHF AFSK tone standard has been to use the "high tones" (2125 Hz mark and 2295, 2550, or 2975 Hz space); you must use a high-tone demodulator to be compatible! In Europe, in particular, the reverse standard is developing - the IARU "low tone" (1275 Hz mark and 1445, 1700, or 2125 Hz space) is the standard to be observed. The two systems are basically incompatible for VHF AFSK operation! Due to low-pass filter parameters, use of data rates greater than 110 BAUD is not recommended when "high" or "low" tone demodulator combinations are used; an external modem should be used for transmissions at 300 baud.

Each tone set has its advantages and disadvantages - the CWR6850 lets you choose the optimum combination for your station. Some of the considerations for each tone set are as follows:

HIGH TONES (Mark = 2125 Hz, Space = 2295, 2550, or 2975 Hz):

Advantages:

1. High tones are the U.S. VHF AFSK standard - their use is required for compatibility when operating VHF AFSK in the U.S. A high tone demodulator may be used for both VHF and HF use in the United States.
2. When high tones are used on HF, using tones into a LSB transmitter audio input (microphone or phone patch input - see Chapter 4), there may be fewer problems with spurious signals (usually due to overdriving the transmitter audio stages). Since the tone frequencies are high, the harmonics and most distortion products occur at audio frequencies beyond the audio passband of the transmitter and should therefore not be transmitted.

Disadvantages:

1. The relatively high audio frequencies used in the high tone set may not fall within the audio frequency response of the receiver or transmitter. In general, the standard amateur shift, 170 Hz, will pass most current receivers and transmitters (the Collins S-Line is an exception). However, few pieces of equipment will pass the tones for both receiving and transmitting 425 or 850 shift with high tones (the Drake TR-7 is an exception). The use of high tone demodulators for HF RTTY is therefore restricted to transmission of just 170 shift, and only receivers incorporating either a variable BFO or pass-band tuning will receive all three shifts.
2. High tones are not the IARU standard and will not be compatible with VHF AFSK in many countries of the world.

LOW TONES (Mark = 1275 Hz, Space = 1445, 1700, or 2125 Hz):

Advantages:

1. Low tones are the IARU international standard and their use assures compatibility with VHF AFSK operations in many areas of the world.
2. Low tones can be used with virtually all SSB receivers and transmitters for all three standard shifts. Variable BFO or passband tuning features are not required to assure good reception of 425 and 850 Hz shift stations.

Disadvantages:

1. Low tones are not compatible with existing U.S. VHF AFSK operations. Since there is a great deal of high tone AFSK equipment already in use in the United States and neighboring countries, it is unreasonable to expect that the U.S. standard will shift to low tones.
2. When low tones are used with a LSB transmitter to generate F1 RTTY emissions (see Chapter 4), there is a strong probability that over-driving the transmitter audio and modulator stages will result in spurious harmonics and mixer products that will be radiated. Of course, these problems will not occur if the audio drive level is properly set.

Although you may develop your own personal preferences, we recommend that you consider the following operating conditions as a starting point:

In the United States:

Use HIGH tones for all VHF AFSK amateur communications and for normal 170 Hz shift HF operation; use LOW tones when receiving HF commercial RTTY stations unless you have a receiver with a variable pitch BFO or with IF pass-band tuning. The exception applies to use of the older Collins S-Line equipment - use LOW tones for all HF operations, amateur or commercial.

In Europe (and all other areas where IARU standards apply):

Use LOW tones exclusively for both VHF AFSK and HF operations. The only exception would be when you communicate with another VHF AFSK station who is using HIGH tones.

### 3.4 Receiving Morse Code

Morse code reception with the CWR6850 requires very little change in switch settings from those used for RTTY in section 3.2; just change the CW/RTTY to CW from RTTY and retune the receiver to a CW (Morse code) signal. Refer to the tables in section 3.2 for the rest of the switch settings. Use USB or LSB for CW reception now and do NOT select the narrow CW filter at this time. Tune the receiver to the CW segment of the 14 MHz band, 14.000 to 14.080 MHz.

There are two tuning monitors available to indicate correct receiver tuning for Morse reception - the CW LED on the CWR68MO front panel, and audio tone frequency comparison using the internal audio monitor. The CWR6850 receive circuit is designed to lock onto an 800 Hz tone, so tune your receiver until the CW LED flashes in sync with the CW signal (key down = tone on = LED on). When the CWR6850 is receiving CW signals, the filtered and detected Morse data is connected to both the microprocessor for decoding and to the CW side-tone oscillator. Thus the received CW signal is regenerated in the CWR6850 and you may listen to the processed signal simply by adjusting the VOLUME slide control. Also, since the CW side-tone is set to 800 Hz, the desired receive CW tone, you can do a very accurate frequency comparison between the receiver signal and the regenerated signal by varying the two slide controls, INPUT and VOLUME. Try this on a few signals - you will soon find out that Morse tuning can be very easy!

The CWR6850 includes two internal filtering systems that may be used for reception on Morse code. The first filter is an active bandpass filter, centered at 800 Hz with a -6 dB bandwidth of 150 Hz. Normally, this is all the filtering you will need to receive Morse code. A second PLL (phase-locked-loop) filter may be used that has a lock-range of plus or minus 80 Hz, a "bandwidth" similar to that of the active filter. However, due to the fact the the PLL will abruptly cease tracking a signal whose frequency exceeds the tracking range, the effective "skirts" of the CWR6850 with PLL in use are very steep; the PLL filter will provide any response to a signal frequency beyond its tracking range. Therefore, tuning a CW signal may be considerably more difficult when the PLL filter is used. The PLL filter does, however, offer a considerable improvement in received S/N (signal to noise) discrimination and will track the frequency of a drifting CW signal (within the lock range). The PLL filter may give false reproduction in the face of strong interference since it will lock on the strongest signal within its lock frequency range. On the other hand, the PLL filter may provide a considerable improvement in the "copy" of a weak, noisy signal. The active CW filter stage is always used for CW reception; the PLL filter may be selected by pressing the SPACE FILTER button in. If a receiver with a narrow CW filter and passband IF tuning is used, a great number of signal selection and rejection techniques can be used to isolate your desired receive signal. Tuning indicators that are used for RTTY are not used in Morse reception; only the CW LED is used for CW tuning, although you may "match" the

incoming signal tone with that of the CWR6850's internal sidetone monitor as explained above.

After you have mastered tuning of the Morse code signal, you may notice that what shows up on the screen doesn't always make the best of sense at first glance! This is usually due to the fact that human operators often send imperfect code! When we copy Morse code with our ears and decode in our brains, we can be adaptive and translate what the sending operator "meant to send" instead of what actually was sent. The most blatant examples of this are run-together characters and incorrect spacing between letters and words. It is very easy for the transmitting operator to get in a hurry and run some letters together - particularly on something he's transmitted often like "CQ" or his own call. Since we are also good Morse operators who have sent "CQ" and call letters often, we adapt when receiving by ear and interpret what was intended. The microprocessor, on the other hand, is looking for some long CW character (like `-.-.---.-` for CQ) that doesn't exist: it therefore displays the underline character (`_`) to show that an unintelligible Morse combination has been received. The CWR6850 SPACE NARROW button may be depressed in such a case to attempt to recover the run-together code. When SPACE NARROW is used, the basis for judging character and word space is shortened to 1 1/2 dot units, rather than 3. This feature may improve the "copy" of hand sent CW but may also distort or garble copy of properly sent CW. When SPACE NARROW is selected, the CWR6850 also may not track sudden changes in received CW WPM rates, particularly if a decrease in speed of more than 12 per-cent is encountered. Use the SPACE NARROW feature only if run-together characters are suspected as the cause of distorted reception.

Similarly, it is a very common thing to insert longer than normal pauses between letters, especially when using a hand key to send Morse. The computer interprets these pauses as spaces between words and puts a space on the screen. When receiving by ear, we tend to group the letters received into recognizable words, ignoring irregularities in spacing.

In these two cases in particular, the computer is a severe critic and "prints 'em as it hears 'em"! On the other hand, the Morse decoding programs are very tolerant of weight variations and will usually correctly decipher a heavy "swing fist" (sometimes called a "Lake Erie swing"). This type of "interface timing" problem will occur with all computer decoding of hand-sent Morse code, much as it will on RTTY if improper or irregular timing is used.

You may notice that sometimes the Morse reception appears to stop or be "locked-up". This is usually caused by reception of a carrier for some period of time. The automatic speed tracking program of the CWR6850 interprets the long carrier as very slow CW and adjusts the speed tracking system for very very slow Morse code. The CWR6850 will readjust the speed tracking back up to the correct signal speed. You will now receive a few "T" and "E" characters as the speed readjusts.

Also, Morse code reception is particularly susceptible to interference when the transmitting station's key is up (between dots and dashes or between letters and words). Comparing RTTY and Morse techniques for the moment, recall that the RTTY signal is sent by frequency shifting a signal (the RF signal for HF, and audio tone for VHF AFSK); for either mark or space RTTY data conditions, there is a definite signal transmitted. On Morse code, the transmitter carrier is turned on when the key is down (mark), but when the key is up (space), there is no signal to be received; your receiver and particularly the automatic Morse detection circuits are now "wide-open" to reception of noise, other signals, etc. This is a basic disadvantage of the on-off A1 type emission we use for Morse versus the F1 or F3 emissions we use for RTTY. If we used F1, frequency shift keying, for Morse transmission (as do many commercial networks), automatic CW reception would be much improved. Here again, when we copy CW by ear, we are adaptive and "tune-out" interference and noise in the pauses between dots and dashes; the computer looks at all signals!

Therefore, it is not realistic to assume that the computer will do all the work of Morse reception for you, especially when receiving less than perfect CW! On the other hand, if you tune to another station using a keyboard or a professional CW operator (such as on the ship-to-shore frequencies), the CWR6850 will display received Morse with close to RTTY-like perfection.

If your receiver has a narrow-bandwidth CW filter, yo9 may now wish to try it for CW reception. Tuning the signal will be a lot more critical, but you may improve the "copy" noticeably if interference has been a problem. Conversely, the narrow filter may actually degrade the copy, especially if the narrow filter "rings" on noise! The degree of problem caused by filter ringing varies with the filter, receiver, and noise conditions, so you will want to experiment with your own equipment. Often, the effects of noise, both with or without a narrow filter, can be minimized by reducing the RF gain control until the AGC no longer controls the receiver gain, increasing the receiver volume control as required to maintain copy. This technique, of course, makes the receive system more susceptible to fading ("QSB") and will require more active participation on your part in adjustment of the RF gain control. Good Morse reception will require some patience and practice until you "get the hang of it".

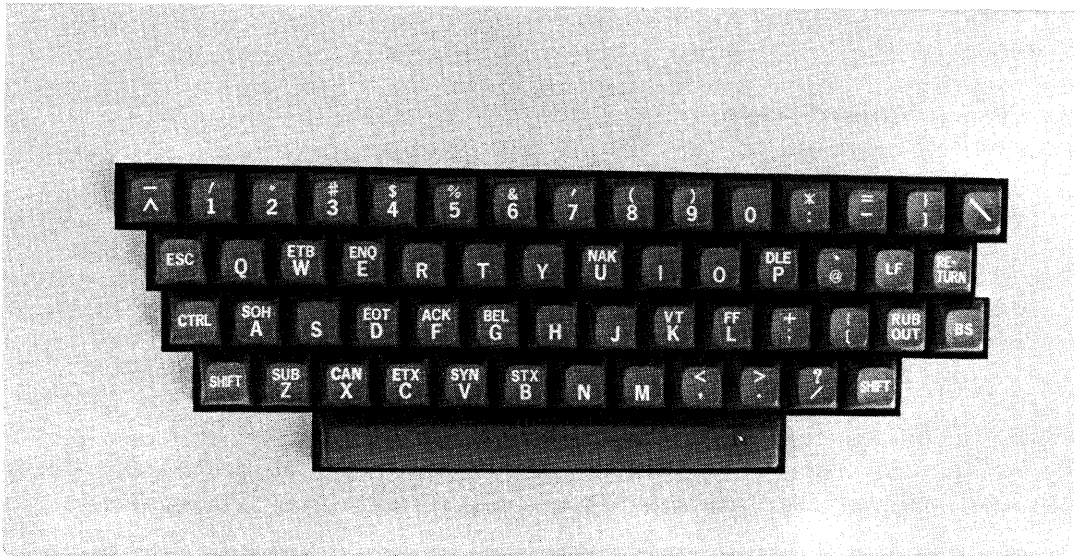

Figure 3. The CWR6850 Keyboard

## CHAPTER 4

## TRANSMITTING WITH THE CWR6850

This section of the manual will discuss the transmitting features of the CWR6850. Extensive use will be made of transmitting using the Morse mode and the CWR6850's internal side-tone monitor to illustrate various transmit actions. Unless otherwise noted, all actions demonstrated while in Morse mode also apply to RTTY modes.

## 4.1 The Keyboard

The keyboard for the CWR6850 is a small separate unit, attached to the CWR6850 through a flexible cord. This keyboard can be placed on the operating table, or you may prefer to try the "easy chair" approach, holding the keyboard in your lap.

As shown in Figure 3, the keyboard has 55 keys, arranged similar to those on a standard typewriter with "extra" control keys to the left and right of the alphanumeric group. Two, three, or four different characters may be typed by using the SHIFT, CTRL (control), or SHIFT with CTRL keys in conjunction with the gray keys. The actual characters or functions generated with each combination varies to some degree with the code selected (ASCII, BAUDOT, or MORSE); details of these special combinations will be explained more fully in later sections of this manual.

In general, use the keyboard as you would a typewriter, making use of the SHIFT key when required. For example, typing on just the "1" key will enter a number 1 for transmitting; SHIFT-"1" would enter an exclamation point, "!". As on a typewriter, hold the SHIFT down while striking the second key. Similarly, when ASCII is used, striking "G" will enter a lower case "g", SHIFT-"G" an upper case "G", and CTRL-"G" will transmit the code for the signal bell. The double combination, SHIFT-CTRL-"G" produces the same output as "CTRL-G" (bell). (Note: upper and lower case letters are only available in ASCII code when the "LOCK U.O.S./ON button is OUT; only upper case letters are available in Baudot and CW.)

The standard alphabet, numbers, and punctuation symbols are all located on gray colored keytops; the blue keys are for control or special uses. The BS (Back Space) key allows you to edit any errors you may have made while typing. Each operation of the BS key will back-up the keyboard cursor one space, removing any characters previously occupying that position. Note that the function of the BS key and the RUB OUT key is different. Use BS for editing; the RUB OUT key generates the ASCII RUB OUT (DELETE) command. Use of the RUB OUT key is discussed in more detail in section 4.3.



## 4.2 Transmit Features

In addition to the features discussed above with regard to the keyboard, the CWR6850 with keyboard offers many transmit features, giving a great deal of operational flexibility. These features will be discussed in detail throughout this chapter, but here is a summary of the most important ones.

Text typed on the keyboard can be entered into the CWR6850 in a form of "split-screen" mode. The dotted lines on the screen are reserved for transmit text entry. Three lines of transmit text are shown on page 1 and all fifteen lines are shown on display page 2. Any or all of these lines of transmit "buffer" may be typed while receiving.

An automatic transmit-receive control circuit is provided so that the CWR6850 can control the transmit-receive operation of the station, turning the transmitter on when text is to be transmitted and off when transmission is complete. The KOS feature (for Keyboard Operated Switch) is discussed in Section 4.13.

The CWR6850 can transmit (and receive) from various I/O (Input/Output) devices using several different I/O interfaces. For example, data can be interfaced from audio sources (receiver, transmitter, tape recorder) or with TTL data connections (computer, some machines, and modems). Use of these I/O connections is discussed in Chapter 5.

To demonstrate use of the transmit features, we will use the CW (Morse code) mode, listening to the CWR6850 sidetone monitor. For the present, a transmitter connection will not be required. Please set-up the CWR6850 front panel switches as shown on the following page.

You may notice that a switch setting is given for all switches, even though many have no effect in CW mode; these switch settings will be used for the RTTY explanations that follow this section.

Press and release the RESET button on the CWR6850 to clear-out any text that may remain on the screen. Now, type a line of text on the keyboard - such as "Now is the time for all good men" (do not use the RETURN or LF keys at this time). Notice how the text you've typed is displayed on the top line of dots at the bottom of the screen. Also note that all the letters typed are capitalized - this is because there is no upper/lower case in Morse code; Baudot is the same. ASCII code, however, does have valid codes for both upper and lower case letters and either may be typed (LOCK button out). You may find it useful to refer to APPENDIX A and APPENDIX B at the end of this manual for a discussion of control commands and screen formats.

## CWR6850

RESET ON	=	Press and release
FILTER ON	=	Off (button out)
SPACE / NARROW	=	Off (button out)
CWID A / CWID B	=	CWID A (button out)
DISPLAY: PAGE ON	=	No action at present
MODE A/MODE B	=	MODE B (button in)
CW / RTTY	=	CW (button out)
ASCII / BAUDOT	=	BAUDOT (button in): No effect on CW
LTR ON	=	No action: No effect on CW
FIG ON	=	No action: No effect on CW
LOCK - UOS ON	=	ON (button in): No effect on CW
NOR / REV	=	NOR (button out): No effect on CW
BAUD	=	45.5 (left button): No effect on CW
SHIFT	=	170 (left button): No effect on CW
TONE	=	HIGH (left button): No effect on CW
RX / TAPE	=	RX (button out)
INPUT (slide control)	=	5 (mid-position)
VOLUME (slide control)	=	5 (mid-position)
SPEED (slide control)	=	5 (mid-position)
FINE (slide control)	=	0 (detent): No effect on CW
SEND / AUTO / RECEIVE	=	RECEIVE (lever down)
ON POWER	=	ON (lever up)
FSK DEMOD (rear panel)	=	INT: No effect on CW
AFSK GAIN (rear panel)	=	Maximum CW: No effect on CW
BRIGHT (rear panel)	=	Maximum CW

Now, transmit the text by using the SEND switch on the front panel. The words should now be transmitted in Morse code at approximately 20 words-per-minute (WPM) and you should hear the CW in the CWR6850 side-tone monitor output (re-adjust the VOLUME slide control if necessary). The CW transmit speed is adjusted with the SPEED slide control. Notice that as all of the pretyped characters are transmitted, the characters in the transmit buffer are shifted to the left. After all the pretyped characters have been transmitted, notice that any new characters are transmitted as typed. This is called "continuous mode" and is the normal method you will probably use to send CW. A "word mode" is also available for transmitting and will be discussed shortly.

Next, try typing several lines of text, letting the transmit output continue. At 20 wpm Morse speed, it is fairly easy to get several lines ahead of the transmitted data (if you wish, slow-down the

transmit speed by adjusting the SPEED slide control). Try using the "BS" (Back Space) key now and note that you can back-up several words for corrections. In fact, you may back-up clear to the transmit output if you choose. Notice that the RUB OUT key is NOT used to correct typing errors in the transmit buffer. It is only used to send the ASCII RUB OUT character (DEL = 111 1111) or to end HERE IS message programming as discussed in section 4.3.

The "word mode" may be actually more convenient for editing since it transmits a word at a time instead of a character at a time. To turn on "word mode", type "CTRL-Y" (hold CTRL while pressing and releasing the "Y" key). A letter "Y" will appear on the status line indicating that "word mode" is active (between the "P" for printer on and the page number "1"). Now, type several more words on the keyboard, separating each word with the space bar. Stop typing and notice that all but the last word has been transmitted; do not include a space after the last word typed. Use the "BS" (Back Space) key to delete one letter at a time, up to the first character position. Retype another word (no space bar yet); the word is displayed but not transmitted. Now, hit the space bar; the whole word is now transmitted. Therefore, in "word mode", the last word typed will be held until the space bar is hit.

Now, set the CWR6850 back to "continuous mode" by typing CTRL-Y again ("Y" on status line disappears) and set the lever switch to RECEIVE. Type four or five lines of text. Notice how only the first three lines of text are shown on the screen. Switch to page 2 of the display using the PAGE button (one press). Now all lines typed show on a much larger dotted area of the screen. Page two shows all fifteen lines available for pretyped text plus the last three received lines of text and the status line. You will probably use page 2 often if you precompose much transmit text. Cycle the PAGE button four times and notice that other display pages, 0 and 3 may also be viewed. Switch from MODE B to MODE A and notice that only pages 0 and 1 may be viewed. MODE A is intended primarily for receive applications and MODE B will be used when you desire to both transmit and receive. The extra lines on page 3 show the contents of the "HERE IS" memory channels and will be discussed in Section 4.3. The formatting of all four display pages is explained in APPENDIX B. For the present, put the switch back to MODE B and select page 2 for display. Transmit the text by selecting the SEND switch position. After the text has been transmitted, select RECEIVE.

There are two ways in which the transmit-receive control of both the CWR6850 and the transceiver can be done automatically. These are most easily demonstrated by using the RTTY mode. Set the CW/RTTY switch to RTTY (button in). When transmitting, the RTTY tones will be heard through the CWR6850 internal monitor (adjust volume with the VOLUME slide control). Leave "word mode" turned off for now (CTRL-Y; no "Y" character on the status line).

The first of these techniques involves the CTRL-X key command (indicated by "X" on the status line). To test CTRL-X automatic operation,

set the switch to RECEIVE and type several lines of text. Now, put the SEND-AUTO-RECEIVE switch in the AUTO position and type CTRL-X. The pretyped text will now start transmitting. While the text is being transmitted, type CTRL-X again. The "X" will disappear from the status line, transmitting will stop and the RTTY tone will turn off. Restart transmission with the command and let all the text be transmitted. Now, type more text; notice that all letters are transmitted as you type them and that the RTTY tone continues. The CWR6850 will remain in transmit mode for as long as CTRL-X is active ("X" on status line); you will NOT receive text if CTRL-X is active. Also, the SW OUT - REMOTE control signal remains in transmitter-on condition for as long as CTRL-X is active.

The second transmit-receive control uses the CTRL-A key command (letter "A" shown on status line). To test this mode, make sure that all text is transmitted out of the transmit buffer using the CTRL-X command or SEND switch position as explained above. Now, put the switch in the AUTO position again and type CTRL-A ("A" appears on status line). Type a word and stop. Notice that the RTTY tone turns on when you first start typing, the RTTY characters are transmitted after a short delay, and the single mark tone turns off after another short delay. Start typing again and the tone will turn back on and transmit data for as long as there is text to be transmitted. The SW OUT - REMOTE control signal is in transmit condition whenever you hear the tone; a transmitter controlled by this signal would be "on-the-air" during this time. The short delay of constant tone at the start of transmission allows the transmitter and antenna control circuits and relays to "settle" to transmit condition before data is released. This also allows the receiving station's autostart receive circuit to activate. The delay at the end of the RTTY transmission helps to "smooth-out" variations in typing speed, preventing multiple on-off transmitter operations as your typing speed varies. You will probably prefer to use "word mode" (CTRL-Y) when using the CTRL-A automatic control to assure that the transmitter doesn't turn on and off during typing pause. Remember that a word will not be transmitted in "word mode" until AFTER the following space is typed. You may return to a receive-only condition by simply typing CTRL-A again.

The CTRL-X and CTRL-A commands interact in the following manner:

1. If CTRL-X is active and CTRL-A is typed, the CWR6850 switches to CTRL-A automatic mode. A second CTRL-A turns off BOTH CTRL-X and CTRL-A features.
2. If CTRL-A is active and CTRL-X is typed, the CWR6850 switches to the CTRL-X mode and the transmitter remains on. A second CTRL-X command turns off both CTRL-X and CTRL-A features.

A somewhat confusing condition can arise if CTRL-X is used to stop transmission midway in the pretyped text when "word mode" (CTRL-Y) is also being used. In this case, a CTRL-X will stop transmission, but a second transmission may not restart transmission until AFTER a space bar operation is performed - the CWR6850 "word mode" "looks" for the

space bar to resume transmission.

Other useful key combinations for use when composing transmit text are (see APPENDIX A for a full list of available commands):

COMMAND	ACTION
BS	= Back Space: back-up cursor one space and remove the character from that space.
CTRL-Z BS	= Delete the final line of data in the transmitter buffer area.
CTRL-Z SHIFT-	= Delete all text in the transmitter buffer.

Reviewing the previous commands:

CTRL-Y	= Turn-on / turn-off "word mode" (indicated by "Y" on status line).
CTRL-X	= Turn-on / turn-off transmitter; transmitter is on whenever "X" appears on status line: only works in AUTO switch position.
CTRL-A	= Turn-on / turn-off automatic transmitter control; transmitter is on when "A" appears on status line AND there is text to be transmitted. Only works in AUTO switch position.

### 4.3 Use of the HERE IS Messages

The CWR6850 has six 64 character message storage areas in which you may store station call letters, name, location, etc. These storage areas are shown on the upper section of page 3 of the display. The HERE IS memories are designated by the reverse-video numbers 0 through 5 in the left-column. Use the following procedure to write messages to the HERE IS message memories:

To store "DE JOHN, WQ9XYZ, DECATUR, ILL" in HERE IS #1:

Type:	"CTRL-W": "1"
See:	Page 3 displayed
Type and see:	"CR CR LF DE JOHN, WQ9XYZ, DECATUR ILL CR CR LF"
Type:	"RUB OUT"
See:	Original page you were viewing before programming.

Notice that the sequence "CTRL-W": "1" (hold "CTRL" while hitting "W"; type "1" after releasing both "CTRL" and "W") starts the programming and automatically changes the screen to page 3 and the "RUB OUT" ends the programming and changes the display back to your original page. The "CR CR LF" sequence at the beginning and end of the text is optional - it will help assure that the other station's RTTY equipment prints your ID on a separate line.

Next, transmit the HERE IS #1 message with the "CTRL-R":"1" key sequence. A reverse video "1" is shown in the transmit buffer area; when transmitting is enabled (with SEND switch or with AUTO - CTRL-A or CTRL-X as explained in the previous section), the text of the HERE IS #1 message is placed on the blank line of the screen above the status letters and then transmitted. If the "call" to the HERE IS message were included in other keyboard typed text, the reverse video number will be entered at the appropriate place and be transmitted only after preceding text has been transmitted. For example, suspend transmission temporarily and type three or four words, then "call" the message (with CTRL-R:1), and type several more words. Now, enable transmission and watch how the HERE IS message is expanded and transmitted when its turn comes.

The same procedure works for programming and reading all 6 HERE IS messages. HERE IS #0 is special in that a CW ID may be included within its program. An example of a HERE IS #0 program is:

```
Type:          "CTRL-W":"0"
See:           Page 3 of display
Type and see:  "CR CR LF DE JOHN, WQ9XYZ CR CR LF * DE WQ9XYZ *
               CR CR LF" (* in reverse video)
Type:          "RUB OUT"
See:           Original display page.
```

This example will send both an ID in RTTY and then switch to CW at the reverse video star (\*), send the "DE WQ9XYZ" in CW, and switch back to RTTY for the final "CR CR LF" sequence. The CWID A / CWID B front panel switch makes a difference here: in CWID B position, the CW ID is transmitted using mark-space AFSK; in CWID A position, the CW ID section is transmitted on the CW key output line as well as the FSK data output line. Most RTTY operations where AFSK tones are used on the microphone input jack should use the CWID B position; you may use CWID A for CW or when you are using direct FSK of a transmitter oscillator. Notice that the phrase "CW ID FOLLOWS" was NOT included in the above example - it isn't necessary, especially if the CR/LF commands are used to prevent garble overprint on the other station's printer. Try "calling" this HERE IS 0 message while transmitting text. Listen to the output tones and try both CWID A and CWID B switch positions.

The switch between RTTY and CW AFSK can be made anytime in the typing of transmit text and does not necessarily have to be included within the HERE IS 0 message. If you wish to insert a CW AFSK section within a typed RTTY text, type a "CTRL-Z":"SHIFT-\*" command before and after the CW section of text. The stars will be written into the transmit buffer and the CWR6850 will automatically switch to AFSK CW when it encounters the starred section. Another command, "CTRL-I" will switch the transmitted output immediately from RTTY to CW for whatever text remains in the transmit buffer. A second "CTRL-I" will switch back to RTTY. The switch is indicated by a reverse video star (\*) in the echoed text in the receive buffer.

The contents of all six HERE IS memories may be transferred to tape and be reloaded from tape, thus saving them during times that the power to the CWR6850 is turned off. To save the HERE IS messages, use the following procedure:

1. Connect the tape recorder audio input (microphone or auxiliary input) to the AFSK OUT - TAPE connector on the CWR6850.
2. Select ASCII and 110 BAUD on the CWR6850.
3. Make sure that your desired messages are stored in all 6 HERE IS memories.
4. Put tape in the recorder and start recording.
5. Type CTRL-S and RETURN.
6. Tones will be transmitted to the tape recorder (listen to them by adjusting the VOLUME slide control).
7. When the "deedle-deedle" stops and you hear a steady tone, stop the tape recorder; the HERE IS memory contents are now stored on your tape.

To load the HERE IS memories from a tape you have made previously, use the following procedure (for a demonstration, turn the CWR6850 off and back on to erase the previous text):

1. Connect the tape recorder audio output (speaker jack, usually) to the AF IN - TAPE rear panel jack.
2. Select ASCII, 110 BAUD, and TAPE (on RX/TAPE switch) on the CWR6850.
3. Rewind the tape to the beginning of the previously recorded section.
4. Type CTRL-L and RETURN (see reverse video "L" on status line).
5. Play the tape into the CWR6850 (listen to tones using INPUT slide control to adjust the volume).
6. The reverse video "L" will go out and the tone frequency will be constant when the loading is complete.
7. Select page 3 to be sure that the messages have all been loaded.

**\*\*\*CAUTION!\*\*\***

Do NOT use the CTRL-L RETURN command sequence unless you are intending to load the HERE IS memories from tape. Control of the CWR6850 is passed to the tape input data until loading is completed (indicated with an ASCII STX character placed on the tape during the save recording). The CWR6850 will appear to be "locked-up" when expecting a memory load from tape and NO further operations may be made until the proper end command is received!

To review, these are the commands to remember when using the HERE IS memories:

COMMAND	ACTION
CTRL-W:n	Start programming HERE IS message #n (n 5 = cancel CTRL-W command)
RUB OUT	Stop programming of current HERE IS message
CTRL-R:n	Read HERE IS program #n for transmitting (See reverse video #n in transmit area; n 5 = cancel CTRL-R command)
*(HERE IS 0)	Start and end CW ID section
CTRL-Z:SHIFT-*	Start and end CW section of RTTY text in normal transmit text buffer area.
CTRL-I	Change transmit mode of entire buffer from RTTY to CW; second CTRL-I changes back to RTTY.
CTRL-S:RETURN	Save the contents of all 6 HERE IS messages on tape (use ASCII, 110 BAUD).
CTRL-L:RETURN	Load the contents of all 6 HERE IS messages from tape (use ASCII, 110 BAUD, TAPE IN).

#### 4.4 Special Considerations When Transmitting Morse

Morse code may be transmitted with the CWR6850 by selecting MORSE with the CW switch button in the "out" position. The CW receive speed automatically adjusts to variations in the speed of the received signal; to change the Morse transmit speed, use the slide SPEED control (up for faster speeds and down for slower speeds). Select CWID A (button out) for CW transmissions.

The CWR6850 also includes the capability of transmitting several common Morse code prosigns. These special characters are transmitted as run-together characters as you would send them by hand. The following key combinations are used to transmit the prosigns:

PROSIGN	KEYBOARD SYMBOL	KEY OPERATION
AA	@	@ key
AR	+	+ key
AS	^	^ key
BK	]	] key
BT	=	= key
CL	%	% key
KA	[	[ key
SK	LF	LF key
SX	\$	\$ key
VE	>	> key (SHIFT - period)
error(HH)	<	< key (SHIFT - comma)



The Continental Morse Code used in the CWR6850 is shown in Table 1.

TABLE 1. CONTINENTAL MORSE CODE

A	.-	1	.-----	
B	-...-	2	..-----	NOTES:
C	-.-.-	3	...-----	
D	-..-	4	....-----	. = one dot unit of key down time
E	.	5	.....	- = one dash unit of key down time
F	..-.-	6	-.....	(space) = three dot units
G	--.	7	--...-	
H	....-	8	---...-	Element space = one dot unit
I	..-	9	----.	Letter space = three dot units
J	.----	0	-----	Word space = seven dot units
K	-.-	.	.-.-.-	
L	..-.-	,	--...-	Speed in WPM = (dots/min)/25
M	--	:	----...	= 2.4 dots/sec
N	-.	-	-....-	= no. of 0's repeated in 26 seconds
O	---	'	-----.	(1.5% accuracy).
P	.-.-.	/	-...-	
Q	--.-	"	.-.-.-.	
R	.-.	?	..-.-.	AA = @
S	...	AA	.-.-	AR = +
T	-	AR	.-.-.-	AS = ^
U	..-	AS	..-.-	BK = ]
V	...-	BK	-...-.-	BT = =
W	.-.-	BT	-...-	CL = %
X	-.-.-	CL	-.-.-.-.	HR = space bar
Y	-.-.-	HR	.....-	KA = [
Z	---..	KA	.-.-.-	SK = LF
		SK	...-.-	SX = \$
		SX	...-.-.-	VE = > (SHIFT - period)
		VE	...-.	error = < (SHIFT - comma)
		error	.....	

Transmitted Morse code may be monitored using the internal side-tone oscillator of the CWR6850, adjustable with the VOLUME slide control. On the other hand, if your transmitter includes a side-tone oscillator that you prefer to listen to, reduce the VOLUME control.

The CWR6850 has Morse key output circuits to drive either a positive or negative voltage keying circuit. Most older tube-type transmitter circuits used grid-block or negative voltage circuits; most solid-state transmitters use a positive voltage key circuit. Either polarity circuit may be connected to the SW OUT - CW jack on the rear panel. A hand key or Morse code keyer (positive voltage) may be connected to the Telegraph Key rear panel jack to manually transmit CW.

Although most modern transceivers automatically switch between receive and transmit when the "key is pressed" (CW key line switched to ground), the SW OUT - REMOTE control signal also functions in CW mode and may be used to control those transceivers requiring such a signal.

The relative "weight" of the CW transmission may be decreased with the CTRL-D command. The normal Morse code transmitted by the CWR6850 agrees with the international standards for dot and dash length; the time length of the dash is 3 times the time length of a dot. For most applications, this is the correct "weighting" and should be used. However, when sending high speed Morse code, some transmitter keying circuits tend to distort the CW timing by "stretching" the time length of the dots and dashes (usually caused by keying circuit shaping networks and RFI by-pass capacitors). The distorted code can be particularly difficult to "copy". If the "CTRL-D" command is invoked, the dash length is increased by 33%, giving a dot:dash ratio of 1:4 instead of the standard 1:3. Since the dash time is therefore increased, the net word-per minute rate is decreased for a constant transmit speed setting. If the transmit speed is now increased (with the SPEED slide control) to the former CW speed (when CTRL-D was not invoked), the net effect is that the DOT time length in a character transmission is LESS; the "weight" has been decreased. It is recommended that you use the "CTRL-D" command only when sending CW at higher speeds.

#### 4.5 Special Considerations When Transmitting Baudot

Baudot RTTY code may be transmitted with the CWR6850 by pressing both the CW / RTTY and ASCII / BAUDOT switch buttons IN. Baudot data rates are selected with the BAUD switches, 45 through 300 baud. Note that 110 baud and 300 baud data rates may be selected for Baudot use, although these rates are not currently allowed for U.S. amateur applications. At present, only the following Baudot data rates are authorized for U.S. amateur use by the FCC:

PANEL LABEL	ACTUAL BAUD RATE	APPROXIMATE WPM RATE
45.5	45.45	60
50	50.00	66
57	56.88	75
75	74.20	100

Other data rates should not be used for on-the-air U.S. amateur Baudot transmissions but may be used for local use, such as writing letters to the printer, etc.

The Baudot RTTY code uses 5 data bits to specify a given character. Since the 32 possible combinations are insufficient to represent all 26 letters, 10 numbers, and punctuation plus control codes, all 5 bit Baudot codes are used twice. Case shift characters are sent to the printer to signal whether a following character will be a letter case (LTRS) or number/punctuation (FIGS). When using a manual Baudot RTTY machine, special keys are provided for these shift codes, LTRS and FIGS; you must type these extra keys as they are required by the text. The CWR6850 automatically keeps track of the Baudot case code required for a given character and inserts the proper code in the transmitted data as required. Thus a standard typewriter keyboard arrangement is used for Baudot and there is no difference in typing required between Morse, Baudot, or ASCII codes. However, the Baudot code itself does not distinguish between upper and lower case letters and the same code is transmitted whether you type a capital or small letter. The LTRS and FIGS may be manually transmitted if desired, using the "CTRL-O" key combination for LTRS and "CTRL-N" key combination for FIGS.

The transmit features of the CWR6850 include non-overprint, word mode, and continuous mode. The non-overprint feature automatically inserts the printer carriage control codes, two carriage returns (CR), and a line feed (LF) at the end of each 72 character line. Also, the CR, CR, LF sequence is inserted if a space bar is typed after 58 or more characters are typed since the previous CR,CR,LF operation. Thus, you need not be concerned with line lengths and insertion of the proper printer controls - the CWR6850 does it for you! Just start typing! Even though the display screen of the CWR6850 itself is only 32 characters long, your transmitted text will be formatted for a standard 72 (or less) character line. If you wish to transmit shorter lines, such as in a table, etc., use the CR and LF keys.

The actual character transmission rate may be slowed down with the "CTRL-U" command. When "CTRL-U" is used, the characters are transmitted at a slower rate than would normally correspond to the data rate selected, equivalent to the approximate rate that a 25 baud signal would be transmitted. However, the actual baud rate of the data remains at the panel selected 45, 50, etc. baud rate. This is sometimes called the "ker-plunk" mode for RTTY transmission.

A continuous stream of LTRS characters (11111) may be transmitted with the "CTRL-^" command. When used, all further transmission of text from the transmit buffer is stopped until a second "CTRL-^" turns the feature off. In ASCII, the NUL character (000 0000) is transmitted.

The Baudot Code used in the CWR6850 is shown in Table 2.

TABLE 2 BAUDOT DATA CODE

BIT NUMBER 5 4 3 2 1	CASE		NOTES:
	Letters	Figures	
0 0 0 0 0	BLANK	BLANK	Mark = "1" = "low" AFSK tone = "low" TTL condition
0 0 0 0 1	E	3	Space = "0" = "high" AFSK tone = "high" TTL condition
0 0 0 1 0	LF	LF	LF = Line Feed = CTRL-J
0 0 0 1 1	A	-	CR = Carriage Return = CTRL-M
0 0 1 0 0	SPACE	SPACE	BELL = CTRL-G
0 0 1 0 1	S	BELL	STOP = # (FIGS case H)
0 0 1 1 0	I	8	
0 0 1 1 1	U	7	
0 1 0 0 0	CR	CR	
0 1 0 0 1	D	\$	
0 1 0 1 0	R	4	
0 1 0 1 1	J	'	Transmission order = Bit 1 to Bit 5
0 1 1 0 0	N	,	Start Pulse = 1 unit space
0 1 1 0 1	F	!	Stop Pulse = 1.5 unit mark
0 1 1 1 0	C	:	
0 1 1 1 1	K	(	
1 0 0 0 0	T	5	BAUD RATE
1 0 0 0 1	Z	"	AVERAGE WPM
1 0 0 1 0	L	)	SELECT PULSE
1 0 0 1 1	W	2	45.45 60.61 22.00 ms
			50.00 66.67 20.00 ms
			56.92 75.89 17.57 ms
			74.20 98.99 13.47 ms
			110.0 146.7 9.09 ms
			300.0 400.0 3.33 ms
1 0 1 0 0	H	#	
1 0 1 0 1	Y	6	
1 0 1 1 0	P	0	
1 0 1 1 1	Q	1	
1 1 0 0 0	O	9	Special Baudot Features:
1 1 0 0 1	B	?	* Automatic LTRS/FIGS generation
1 1 0 1 0	G	&	when transmitting
1 1 0 1 1	FIGS	FIGS	* USOS (Unshift On Space) select- able for reception of noisy sig- nals.
1 1 1 0 0	M	.	
1 1 1 0 1	X	/	
1 1 1 1 0	V	;	LTRS = CTRL - O
1 1 1 1 1	LTRS	LTRS	FIGS = CTRL - N

As discussed in Section 4.3, a CW identification feature is included in the CWR6850. Current U.S. amateur RTTY regulations (and those of most other countries) require the transmission of the station call letters in Morse code before and after each major transmission. The

CW ID can be conveniently included in the program for the HERE IS 0 memory. The following procedure is recommended for use in formatting a typical amateur RTTY exchange:

WQ9XYZ (your station) conversing with WQ6ZZZ:

Program HERE IS #0 for: "CR CR LF DE WQ9XYZ \* DE WQ9XYZ \* CR CR LF"  
 Program HERE IS #1 for: "WQ6ZZZ DE WQ9XYZ"  
 (see section 4.3 for programming)

Typical transmission:

```
"CTRL-R:0"    (call HERE IS #0)
"CTRL-R:1"    (call HERE IS #1)
"CR CR LF GOOD MORNING, DAVE. HOW ARE YOU TODAY? .....
.....(text) .....(text) .....
.....(text) .....(text) .....
.....SO, BACK TO YOU, DAVE.
"CTRL-R:1"    (call HERE IS #0)
"CTRL-R:0"    (call HERE IS #1)
```

Notice that the "CR CR LF" carriage control characters and both a RTTY and CW ID are included in the HERE IS #0 program; one call to HERE IS #0 satisfies the station's ID requirement. As mentioned in section 4.3, a message such as "CW ID FOLLOWS" is not included since it is not necessary; the "CR CR LF" sequences "isolate" the CW ID section, preventing garbled overprint at the other station.

Baudot RTTY may be transmitted and received in several formats with the CWR6850. Two different demodulator/modulator audio tone sets may be used as explained in Sections 3.3 and 3.4. The transmit tones match the receive demodulator filters to assure true transceive frequency matching. These same tones may also be used to record and play back messages with an audio tape recorder as explained in Section 5.4. Simultaneous with the selected transmit tone output, the data is also available to the SW OUT - FSK connector. The NOR/REV switch effects ONLY the receive demodulator and does not reverse the mark-space sense of the tone frequencies; mark is always the lower audio frequency transmitted.

The KOS (Keyboard Operated Switch) feature is very convenient for RTTY operation of an amateur station. The KOS circuit functions much the same as a VOX - voice controlled break-in - circuit of a SSB transmitter, automatically controlling the transmit-receive switching of the station. To use KOS, select the AUTO switch position and start typing your message. When you are ready to start transmitting, use the "CTRL-A" command (explained in detail in section 4.2). The SW OUT - REMOTE transistor will turn-on the transmitter and, after a short pause (to let the transmitter, amplifier, and antenna relays settle), the first of the typed text will start transmitting. When all of the text has been transmitted, the KOS turns off the transmitter and you may receive. The "CTRL-X" command may also be used for semi-automatic control.

#### 4.6 Special Considerations When Transmitting ASCII

ASCII RTTY code may be transmitted with the CWR6850 by selecting the RTTY and ASCII switch positions. ASCII may be transmitted or received at any of the data rates, 45 baud through 300 baud. Current U.S. amateur FCC regulations do not stipulate specific ASCII data rates that must be used. However, the following are the maximum data rates that may be used for particular frequency ranges:

FREQUENCY RANGE	MAXIMUM DATA RATE	EMISSION
3.5 to 21.25 MHz	300 baud	F1
28.0 to 225 MHz	1200 baud	F1, F2, A2
420 MHz and higher	19,600 baud	F1, F2, A2

Although there are many data rates available for use, 110 baud is used almost exclusively on frequencies below 30 MHz due to popular use, commercially available mechanical machines, and the poor noise performance of higher data rates. On the VHF bands, 110, and 300 baud have proven popular. The internal demodulators of the CWR6850 will not provide optimum signal performance if 300 baud is used; the low-pass filter is set for a narrow bandwidth to give optimum performance at the more common, slower data rates. Use an external modem for 300 baud, such as a "BELL 103 - Compatible" modem.

However, there is a big advantage to use of the slower data rates (45 or 50 baud for example) with the ASCII code in the 3 - 30 MHz frequency range. The slower data rates are considerably more effective when faced with the noise, interference, and varying signal conditions common on these frequency bands. Also, the ASCII code offers a considerably larger character set than the Baudot code normally used at these slow rates.

The CWR6850 will transmit and receive a full ASCII character set, including upper and lower case letters, all punctuation and symbols, and all control codes with the exception of the "US" (Unit Separator) code (001 1111). Each ASCII character and control code has a unique symbol that is displayed on the CWR6850 screen. These symbols are shown in Table 3. The key combinations used to produce the ASCII control codes are also shown in Table 3. Note that it is necessary to press the "ESC" key before typing the "CTRL-n" combination since many of the "CTRL-n" keys are used for CWR6850 control. A complete listing of the ASCII codes is shown in Table 4.

Often, it is desirable to be able to transmit an abridged form of the ASCII code, using only upper case (capital) letters. This feature, called CAPS LK, is turned on with the LOCK / UOS ON switch. In ASCII, this switch selects CAP LK when it is depressed. This feature effects both the transmit and receive sections of the CWR6850 - only upper case ASCII characters may be received and transmitted when the LOCK switch button is in.

TABLE 3. DISPLAY SYMBOLS FOR THE ASCII CODE

CONTROL CHARACTER	SCREEN SYMBOL	KEY COMBINATION
ACKNOWLEDGE	AK	ESC : CTRL - F (ACK)
SIGNAL BELL	BL	ESC : CTRL - G (BEL)
BACK SPACE	BS	BS
CANCEL	CN	ESC : CTRL - X (CAN)
CARRIAGE RETURN	CR	RETURN
DATA LINK ESCAPE	DL	ESC : CTRL - P (DLE)
DELETE (RUB OUT)		ESC : CTRL - RUB OUT
DEVICE CONTROL 1	D1	ESC : CTRL - Q
DEVICE CONTROL 2	D2	ESC : CTRL - R
DEVICE CONTROL 3	D3	ESC : CTRL - S
DEVICE CONTROL 4	D4	ESC : CTRL - T
END OF MEDIUM	EM	ESC : CTRL - Y
ENQUIRY (WRU)	EQ	ESC : CTRL - E (ENQ)
END OF TRANSMISSION	ET	ESC : CTRL - D (EOT)
ESCAPE	EC	ESC : ESC
END OF BLOCK	EB	ESC : CTRL - W (ETB)
END OF TEXT	EX	ESC : CTRL - C (ETX)
FORM FEED (HOME)	FF	ESC : CTRL - L (FF)
FORM SEPARATOR	FS	ESC : CTRL - \
GROUP SEPARATOR	GS	ESC : CTRL - ]
HORIZONTAL TAB	HT	ESC : CTRL - I
LINE FEED	LF	LF
NOT ACKNOWLEDGE	NK	ESC : CTRL - U (NAK)
NULL	NU	CTRL - @ or ESC : CTRL - @
RECORD SEPARATOR	RS	ESC : CTRL - ^
SHIFT IN	SI	ESC : CTRL - O
SHIFT OUT	SO	ESC : CTRL - N
START OF HEADING	SH	ESC : CTRL - A (SOH)
START OF TEXT	SX	ESC : CTRL - B (STX)
SUBSTITUTE	SB	ESC : CTRL - Z (SUB)
SYNCHRONOUS IDLE	SY	ESC : CTRL - V (SYN)
UNIT SEPARATOR		(not available)
VERTICAL TAB	VT	ESC : CTRL - K (VT)

(ESC:CTRL-A = Press and release ESC: press CTRL and A together)

As in the discussion of the Baudot code in section 4.4, the non-overprint feature of the CWR6850 makes it unnecessary to type printer control characters when typing text. The transmit lines are automatically set for a maximum of 72 characters. When the end of a line is over-typed, the CR (carriage return) and LF (line feed) characters are inserted. If you wish to type a shorter line, use the RETURN (CR) and LF keys.

TABLE 4 ASCII DATA CODE

BITS	7	0	0	0	0	1	1	1	1	NOTES:
	6	0	0	1	1	0	0	1	1	Mark = "1"
4 3 2 1	5	0	1	0	1	0	1	0	1	= TTL high
0 0 0 0	NUL	DLE	SPC	0	@	P	`	p		Space = "0"
0 0 0 1	SOH	DC1	!	1	A	Q	a	q		= TTL low
0 0 1 0	STX	DC2	"	2	B	R	b	r		
0 0 1 1	ETX	DC3	#	3	C	S	c	s		
0 1 0 0	EOT	DC4	\$	4	D	T	d	t		
0 1 0 1	ENQ	NAK	%	5	E	U	e	u		
0 1 1 0	ACK	SYN	&	6	F	V	f	v		
0 1 1 1	BEL	ETB	'	7	G	W	g	w		
1 0 0 0	BS	CAN	(	8	H	X	h	x		
1 0 0 1	HT	EM	)	9	I	Y	i	y		
1 0 1 0	LF	SUB	*	:	J	Z	j	z		
1 0 1 1	VT	ESC	+	;	K	[	k	{		
1 1 0 0	FF	FS	,	<	L	\	l			
1 1 0 1	RTN	GS	-	=	M	]	m	}		
1 1 1 0	SO	RS	.	>	N	^	n			
1 1 1 1	SI	US	/	?	O	_	o	RBO		

ACK = acknowledge	HT = horizontal tab	BAUD	CHAR/	SELECT
BEL = signal bell	LF = line feed	RATE	SEC.	PULSE
BS = back space	NAK = not acknowledge			(ms)
CAN = cancel	NUL = null	45.45	4.13	22.00
DC1 = device control 1	RS = record separator	50.00	4.55	20.00
DC2 = device control 2	RTN = carriage return	56.92	5.17	17.57
DC3 = device control 3	RBO = RUB OUT = DEL	74.20	6.75	13.47
DC4 = device control 4	SI = shift in	110.0	10.0	9.09
DLE = data link escape	SO = shift out	300.0	30.0	3.33
EM = end of medium	SOH = start of heading			
EOT = end of trans.	STX = start of text			
ESC = escape	SUB = substitute			
ETB = end of block	SYN = synchronous idle			
ETX = end of text	US = unit separator	Transmission bit order:		
FF = form feed (home)	VT = vertical tab	bit 1 to bit 7		
FS = form separator	ENQ = enquiry = WRU	bit 8 = even		
GS = group separator	SPC = space bar	parity		

The KOS (Keyboard Operated Switch) feature may be used to automatically control the transmit-receive circuitry of the station. The KOS transistor switch will turn-on the transmitter whenever typed text is available for transmission and the transmit output of the CWR6850 is enabled (use AUTO switch position and "CTRL-A" (or "CTRL-X") as explained in sections 4.2 and 4.4).



#### 4.7 HDX / FDX Operation

The CWR6850 may be operated in either a half-duplex (HDX) or full duplex (FDX) transmit connection, selected with the RX / TAPE switch. Normal amateur RTTY communications are usually conducted with equipment connected for half duplex operation. A full duplex connection is often used between a computer and a terminal.

With a half duplex connection, all transmitted text from the CWR6850 may be seen on the screen before and after it has been transmitted. All of the features of the CWR6850 may be used with half duplex. However, the CWR6850 may only receive or transmit one at a time.

When full duplex is chosen, the CWR6850 can receive and transmit text simultaneously. However, transmitted text will no longer be displayed in the receive section of the screen; it will, however, appear in the transmit screen area as usual. Typical full duplex connections with a computer usually include a computer-generated "echo" back to the receive display or printer, showing the characters as received and interpreted by the computer; transmission errors are therefore soon noticed. The complete ASCII and Baudot character sets may be transmitted in FDX mode.

When using full duplex, use the AF IN - TAPE connector for received data; either the AFSK OUT - TX or AFSK OUT - TAPE connector may be used for transmitted tones. The FSK TTL - IN and OUT connectors may be used if the FSK DEMOD switch is set to EXT.

The "CTRL-E" echo command allows some interesting variations of full duplex. When the RX-TAPE switch is set to TAPE and "CTRL-E" is used, received data is loaded into the transmit buffer and you may then retransmit this received data. If the switch is set to RX position and "CTRL-E" is used, text typed on the keyboard is entered into the transmit buffer, transmitted, and re-loaded back into the transmit buffer, forming a continuous loop.

#### 4.8 The KOS Feature

The KOS (Keyboard Operated Switch) feature of the CWR6850 allows automatic control of the transmit-receive circuits of the station in much the same manner as the SSB VOX circuit. Select the KOS feature by setting the SEND-AUTO-RECEIVE switch to AUTO (center position). When you have pretyped your text and are ready to start transmitting, type "CTRL-A". The transmitter will turn on and, after a short delay, transmit the typed text. After all of the text has been transmitted, and after another short delay, the transmitter will turn off. If you type any more text, the transmitter will turn on again and that text will be transmitted. To pretype without further transmitting, type "CTRL-A" again. The "A" on the status line of the screen shows if the automatic KOS feature is active.

The on-off KOS control of the transmitter may be controlled manually with the "CTRL-X" command (shows "X" on status line when active). The "CTRL-X" command turns the transmitter on for as long as the "X" is shown on the status line; you must type another "CTRL-X" to turn off the transmitter, whether there is text to be transmitted or not. More details regarding the "CTRL-A" and "CTRL-X" commands are given in section 4.2.

The KOS switch transistor is NPN and will therefore key only transmitters with a positive voltage tx-rx control line (push-to-talk line, usually). If your transmitter has a negative voltage control line (the Drake T4 is an example), it will be necessary to use a relay or additional transistor switch between the CWR6850 KOS output and the transmitter. This variation is discussed in Section 5.1.

The SEND-AUTO-RECEIVE switch parallels the KOS (SW-OUT REMOTE) jack when it is in SEND position, manually turning on the transmitter.

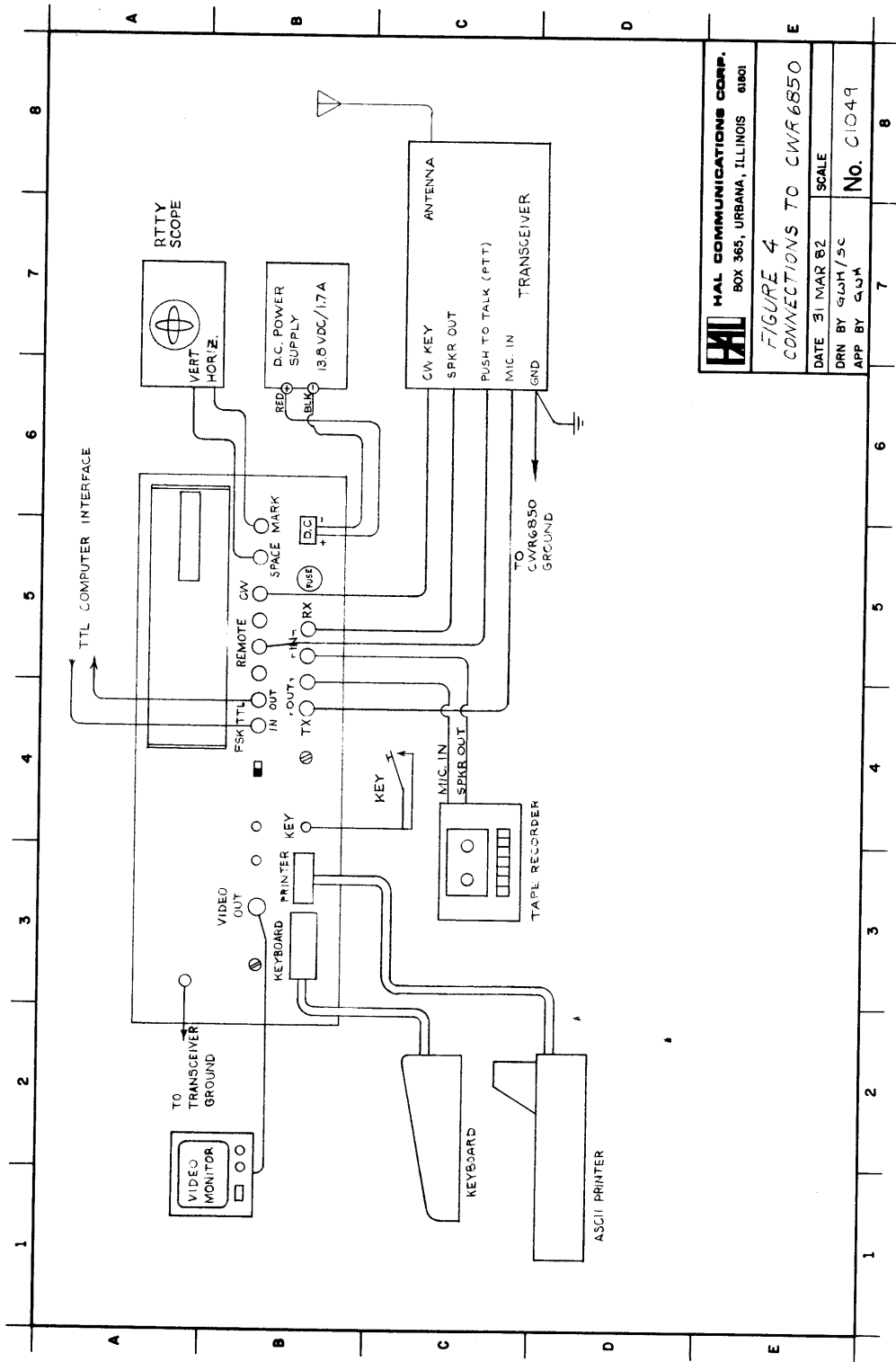

**HAL** MAL COMMUNICATIONS CORP.  
 BOX 365, URBANA, ILLINOIS 61801

**FIGURE 4**  
 CONNECTIONS TO CWR6850

DATE 31 MAR 82 SCALE  
 DRN BY GWH/SC  
 APP BY GJM No. C1049

Figure 4. Connections To The CWR6850

## CHAPTER 5

## CONNECTIONS TO THE CWR6850

This section of the CWR6850 manual discusses how to connect the Telerader to your equipment. Section 5.1 will discuss basic connections you may wish to make in a typical radio amateur station. Later sections of this chapter discuss specialized connections.

## 5.1 Normal Amateur Station Connections

The basic minimum connections required for a transmit-receive station connection have been shown in Figure 2 in Chapter 2; more elaborate connections are shown in Figure 4. The HAL cable set "C2" makes the simple connections or you may fashion your own cables. The "basic required connections" of Figure 2 are:

1. A good RF ground between all components of the system. Use heavy wire or 1/4" shield braid.
2. A shielded audio cable between the receiver speaker output and the CWR6850 AF IN - RX connector. A high fidelity phono cable will do nicely.
3. A shielded audio cable between the transmitter microphone audio input and the CWR6850 AFSK OUT - TX connector. A stereo phono cable can be used for this and the KOS connection described next. Note that the phono connector(s) will probably need to be cut-off on the transmitter end of this cable and the correct microphone plug connected. Consult your owner's manual for the correct connector and pin numbers. The output level from the AFSK OUT jacks may be adjusted if necessary with the AFSK GAIN control. Consult your transmitter manual and insert a series capacitor if required as noted in Section 2.1.
4. A shielded cable between the transmitter microphone push-to-talk (PTT) input and the CWR6850 SW. OUT - REMOTE connector (KOS for Keyboard Operated Switch). The other half of the stereo cable used for transmit audio can be used for this connection. As above, consult the transmitter manual for connector and pin numbers. The NPN transistor KOS switch will only switch positive voltage PTT circuits directly; negative voltage PTT circuits will require an external relay. This relay may be connected as shown in Figure 5.

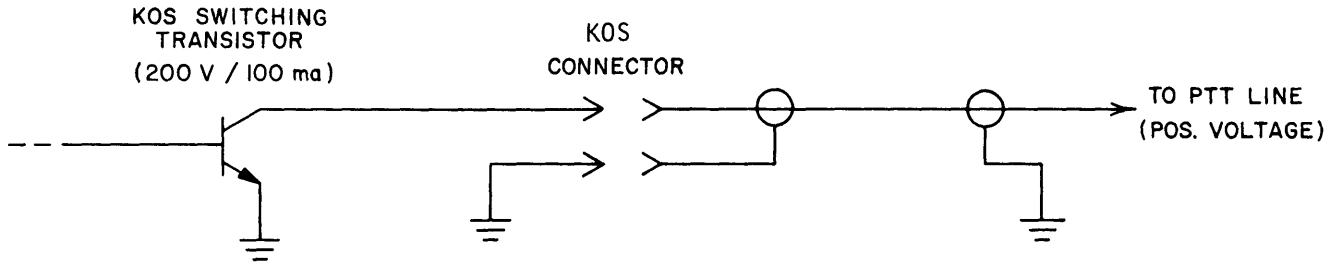

CONNECTION KOS CIRCUIT ( POSITIVE VOLTAGE )

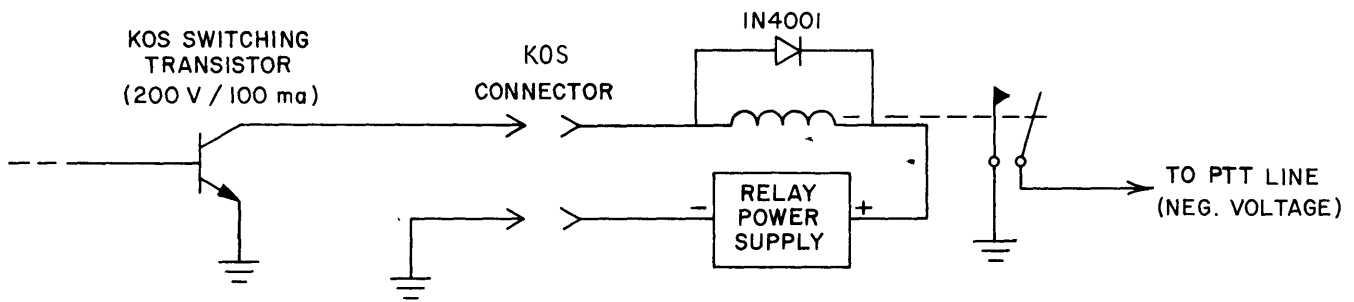

CONNECTION TO KOS CIRCUIT ( NEGATIVE VOLTAGE )

Figure 5. KOS Circuit Connections

5. A shielded cable between the transmitter Morse code key input and the CWR6850 SW. OUT - CW connector. Either a positive or negative voltage keying circuit may be connected to this jack. Again, this cable can be a high fidelity phono cable with the transceiver plug end modified as appropriate. This connection can often be combined in a stereo cable with the receiver audio cable (item 2) when connections are made to a transceiver.
6. Connect the keyboard to the CWR6850 with the cable and connector furnished.
7. Connect the CWR6850 to a DC power source capable of +12 to +14.5 VDC output with a 1.6 Ampere load.

**\*\*\*\*\* CAUTION! \*\*\*\*\***

Be sure that you connect the RED wire to the positive terminal and the BLACK wire to the negative terminal. Reverse power connection may damage both the CWR6850 and the DC power source!

If you use an AC power supply to generate the +12 VDC, use a grounding type of AC connector or provide a separate power ground return for the power supply to prevent any electrical shock.

## 5.2 Use of the TTL Data Connections

The CWR6850 includes input and output connectors for use with TTL data devices ("FSK TTL IN" and "FSK TTL OUT"). These I/O connections can be used with any TTL compatible device. The TTL voltage standard is as follows:

MARK = +2.7 volts (+5.0 volts maximum)  
SPACE = +0.6 volts (0.0 volts minimum)  
UNDEFINED: +0.6 volts to +2.7 volts

Notice that the voltage levels of the TTL standard are NOT compatible with those of RS232 data connections. Do not be misled by some claims of direct TTL - RS232 compatibility; damage may be caused to one or both units! The TTL I/O connections may be used for connection to printers, computers, or other TTL data devices.

The TTL output is always available for all ASCII and Baudot signals; the TTL input is selected with the FSK DEMOD. - INT / EXT switch on the rear panel. Leave the switch in the "INT" position whenever you wish to use the internal demodulator for receiving Baudot or ASCII signals.

### 5.3 Use of the SW-OUT FSK Connection

Some amateur transmitters have provision for direct FSK keying of an internal oscillator. These FSK inputs typically require that a control line be switched between open circuit and ground for the mark and space RTTY conditions. The SW-OUT FSK rear panel jack may be used to control such transmitter inputs. The internal transistor switch of the CWR-685 has maximum ratings of +100 VDC and +100 mA DC; negative voltages cannot be switched. The SW-OUT FSK standard configuration shows an "open circuit" for mark condition and a "closed circuit" (transistor switch "on") for space. However, an internal jumper of the CWR6850 allows this polarity to be reversed, setting mark to "on" and space to "off". Refer to section 6.4 for location of the jumper and connections to be made. It is not recommended that you use this SW-OUT FSK jack to key a high-voltage RTTY loop circuit; use an optical isolator driven from the TTL output instead.

### 5.4 Connection of a Different Keyboard

The CWR6850 is furnished with a reliable full-ASCII keyboard which should give long hours of satisfactory performance. However, it does connect to the CWR6850 using a standard parallel-ASCII interface and another keyboard (or a computer) may be connected in its place. The following are the specifications to be observed when connecting to the keyboard connector:

1. The keyboard must be capable of generating all standard ASCII codes and must generate positive 7-bit parallel output data and a 1 bit negative strobe pulse; set D8 to a logic "low".
2. The keyboard must operate from +5 VDC and require less than 250 mADC.
3. The keyboard connector is a HIROSE 24 Pin Connector, HAL P/N 332-24000.
4. The pin connections are:

1 - Ground	7 - D6	13	
2 - D1	8 - D7		
3 - D2	9 - D8	to	NOT USED
4 - D3	10 - NOT-STROBE		
5 - D4	11 - NOT-ACK		
6 - D5	12 - +5V	24	

The NOT-ACK signal is not used in the CWR6850 on the present keyboard. When interfacing to a computer, check the response from NOT-ACK before entering data.

### 5.5 Connection of an ASCII Printer

A serial ASCII data printer may be used with the CWR6850 by connection to the PRINTER connector. This output is a parallel, Centronics-compatible interface connection. The specifications of the printer connection are:

Connector: HIROSE P-1612-BAC 12-pin plug (HAL 332-12000)  
 Wire: 12 Conductor cable (shielding recommended); 5 ft.

PIN	USE	PIN	USE
1	GND	7	NOT-STROBE
2	BUSY (NOT-RDY)	8	D1 (LSB)
3	NOT-ACK	9	D2
4	D8 (MSB)	10	D3
5	D7	11	D4
6	D6	12	D5

Use a printer that includes a one-line buffer register and will do automatic line feed operations when either the buffer is full or the ASCII line feed character is received (0A HEX). The output of NOT-STROBE is a negative pulse of approximately 1.2 usec. duration. The NOT-ACK input is not read; data is output to the printer when BUSY (NOT-RDY) is in a "low" TTL state. Data output is latched just before the next NOT-STROBE output pulse. The D8 output condition is set to a TTL "low". The output is parallel 7-bit ASCII. The contents of the printer output FIFO register are displayed on the top two lines of page 2 of the display.

Data to the printer is turned on and off with the "CTRL-P" command. When the printer is active a letter "P" will appear on the status line. The printer provides print-out of data AS IT IS RECEIVED. When you use full duplex (normal amateur use), received data is printed as it is received. Since the transmitted text is repeated or "echoed" in the receive buffer, it too is printed. If full duplex is used, only receive data will be printed. Refer to the discussions of section 4.7 for more information concerning full and half duplex operations. Since most printers use a line buffer, text will not be physically printed until an entire RECEIVED line is complete (as distinguished from a 32 character display line). Some printers allow modification of the print format when some ASCII control codes are received. All control codes to the printer except LF are normally suppressed to avoid print format changes on received text (or noise). The commands to the print can be enabled, however, by typing "CTRL-C"; a second "CTRL-C" disables the commands.

## 5.6 Connection of an Audio Tape Recorder

An audio tape recorder may be connected to the AFSK OUT - TAPE and AF IN - TAPE connectors of the CWR6850 for recording and playing back of messages. The AFSK OUT - TAPE connector furnishes the CWR6850 transmit tones to the tape recorder input (microphone or auxiliary input). On transmit, these tones are keyed by transmit data, such as that typed on the keyboard. Thus, you can make-up long "brag-tapes" or messages on the CWR6850 screen and record them as you "transmit" them. You may prevent the transmitter from turning on by temporarily disconnecting the cable to the SW.OUT - REMOTE jack (KOS to PTT con-



nection). The TAPE OUT level may be adjusted with the AFSK GAIN rear panel control.

To transmit tape recorded text, select TAPE on the RX/TAPE switch (button in), type "CTRL-E", turn the transmitter on with the SEND or AUTO switch position (use CTRL-A or CTRL-X as per discussions in section 4.2), and start the tape in the playback mode. The recorded tones are now fed-through the CWR6850 receive demodulator, filtered and detected, and then modulate the CWR6850 transmit output tones (and TTL output). Thus, the tape data is reprocessed before transmission, helping to eliminate some of the distortion otherwise caused by tape wear and stretch. When the taped message stops, type CTRL-E again to end the echo-back feature.

The connection of the tape recorder to the CWR6850 is shown in Figure 5. Use shielded cables for these connections; include RF and safety grounds to minimize any RF pickup in the tape recorder.

### 5.7 RTTY Tuning Oscilloscope Connections

In addition to all of the input/output (I/O) connections discussed above, you may also wish to use an external monitor scope for a RTTY tuning indicator. The OSCILLO (SPACE and MARK) connectors are provided for tuning indicator use. These output are the filtered signals present at the RTTY demodulator discriminator circuits. The signals are approximately 8 V p-p in amplitude and have an internal impedance of approximately 200K ohms. As shown in Figure 4, the standard convention is to use an X-Y oscilloscope with the MARK signal connected to the horizontal scope input and the SPACE to the vertical input. Since these signals have a relatively low output level, it is necessary to use an oscilloscope with amplifier stages in both the vertical and horizontal sections. Use shielded cable for these connections; be sure to include safety power as well as RF ground connections.

The display on the oscilloscope screen for correct receiver tuning will be of the crossed-ellipse type. Correct tuning is indicated when the horizontal ellipse (mark signal) and the vertical ellipse (space) have maximum amplitude (length of the ellipse) and are orthogonal. The 170 Hz shift ellipses will be fairly wide and will not necessarily be at 90 degrees to each other - this is normal! The ellipses for the wider shifts (425 and 850) will be noticeably narrower and closer to a full 90 degrees apart. With practice, the tuning scope provides the most accurate tuning indicator available. Properly interpreted, the scope patterns tell which direction to tune the receiver and whether the signal shift matches that of the selected demodulator shift.

## 5.8 Using a Television Set or External Monitor

Although the internal cathode ray tube (CRT) of the CWR6850 produces an excellent display, you may wish to use an external TV Monitor or TV set to display the text; a larger monitor tube will give a larger character size display. Any standard composite video monochrome TV monitor may be connected to the VIDEO OUT connector on the CWR6850 rear panel. The video output is 1 v p-p, composite video, 75 ohm impedance. Connection of an external monitor does not affect the display on the internal CRT of the CWR6850.

Some good quality black and white TV sets can be easily modified to serve as video monitors. The change does not affect normal operation of the set except that the video cable from the CWR6850 must be removed from the TV when the set is to be used to receive television programs. It is important that the selected TV have adjustments available for both horizontal and vertical size. Normal TV alignment results in "over-scan" of the viewing screen, preventing margin lines but also losing parts of the picture at the edges and corners. To avoid losing characters of the CWR6850 display along the corners and edges, it may be necessary to "shrink" the size of the TV raster with the width and height controls. These adjustments will be made after the TV set is modified and when you can look at the CWR6850 video output.

```
*****
*
*   CAUTION: DO NOT attempt to use as a monitor any television
*             receiver in which one side of the AC line is
*             connected to the chassis or circuit ground of the
*             set unless you supply AC power to the set through
*             an isolation transformer.
*
*****
```

The modification is simply a matter of capacitively coupling the external video signal to the input of the first video amplifier stage in the TV set. Figure 6 shows a typical transistor TV video circuit. Although the component values and the biasing scheme may be slightly different in your set, the circuit should be essentially as shown. The CWR6850 video signal is injected at point A.

The modified circuit is shown in Figure 7. Connect the negative end of a 100 uF, 16 V electrolytic capacitor to the base of the first video amplifier transistor. Mount a UHF (or BNC) video connector on the cabinet as close as possible to the capacitor connection. Connect the center pin of the coax connector to the positive end of the electrolytic capacitor. Use hook-up wire if the connection is less than 6 inches; use a small coaxial cable such as RG174 for longer connections.

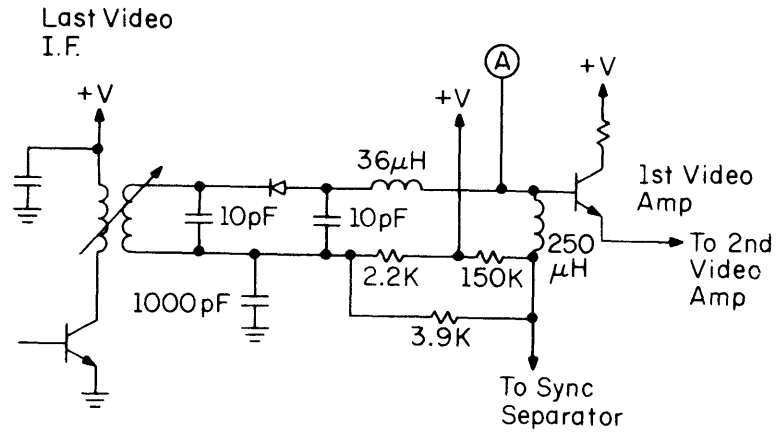

Figure 6. Typical Video Detector

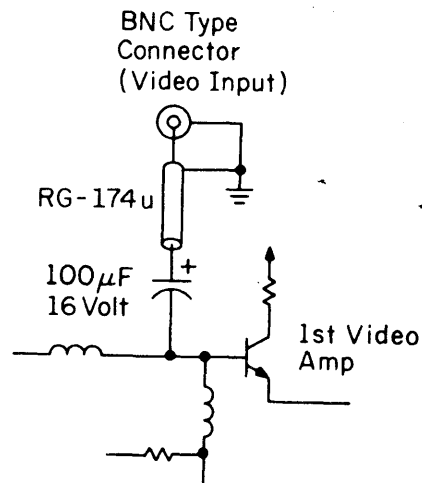

Figure 7. Modified Video Detector

## 5.9 RF-Induced Problems

The CWR6850 is designed to operate in close proximity to radio frequency transmitting and receiving equipment. However, under certain conditions in an RF-saturated environment, the CWR6850 may be susceptible to RF-induced interference. This may manifest itself in any of a number of ways, such as partial or complete lack of response to switches or keyboard operations, or erratic behavior of the video display.

The first thing that should be checked if RF problems are suspected is the GROUND system. The transmitter should be properly grounded for RF (in addition to an electrical safety ground) and all other station equipment grounds should be connected to the transmitter chassis. The RF ground should consist of a short length of heavy copper wire or braid terminated at a good earth ground (ground rod, cold water pipe, etc.). If a water system ground is used, be sure that the pipes are 100 percent metal from the connection point to the water mains - plastic plumbing will break the ground path. If the distance between your transmitter and ground connection is more than a quarter wavelength at the highest operating frequency, make the ground wire an integral number of half-wavelengths long. If you plan to operate 10 and 15 meters, you may need to run separate ground wires for each band.

Stations located on the second floor of wood frame houses can present special problems for RF grounding. One technique that has worked well when none of the usual ground returns work is to spread copper screen material on the floor of the room under the operating position. The equipment ground is then attached to the screen with one or more low inductance leads. The screen creates an "artificial" ground plane in the studio. A carpet is usually placed over the screen to improve the appearance of the room! Consult any of the amateur handbooks or antenna books for a more in-depth discussion of grounding techniques.

The best way to confirm that a problem is caused by RF-induction is to temporarily eliminate the source. This may be done in stages, starting with a partial reduction in exciter drive, and ending with transmitter shut-off. Since RF energy may be induced in the CWR6850 through several paths, connecting the transmitter to a dummy load may not eliminate all RF related problems, although this is an excellent first step in verifying RF problems.

POOR

WORSE

CORRECT

BEST

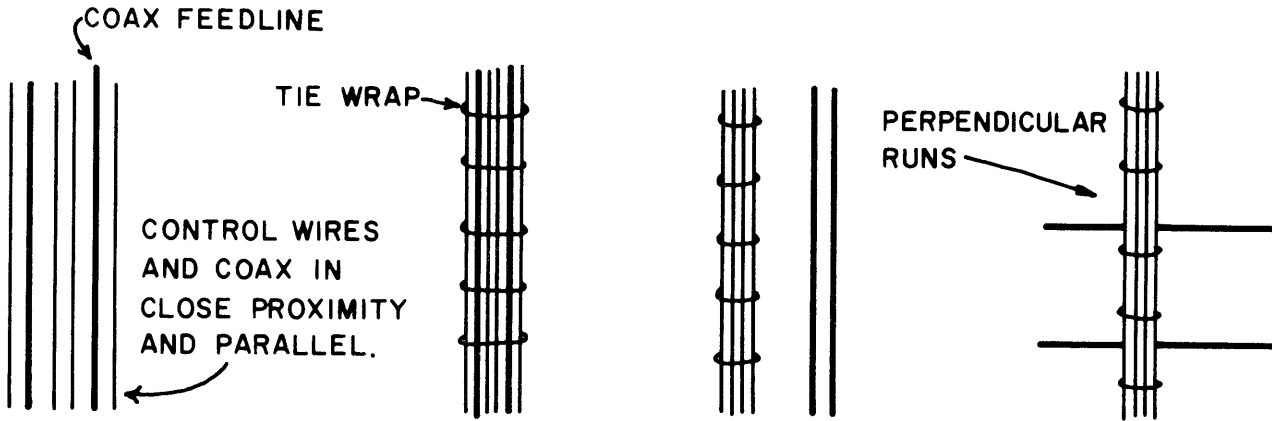

(A)

PLACE RF CHOKE CLOSE TO REAR PANEL OF EQUIPMENT

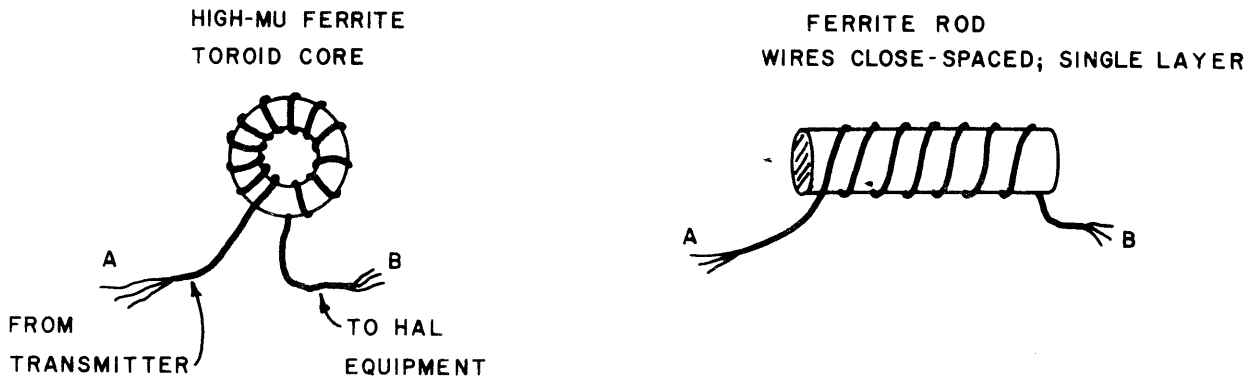

(B)

Figure 8. RFI Reduction Techniques

Radiation of RF energy from linear amplifiers, antenna tuners, coaxial switches, monitor scopes and interconnecting coaxial cable jumpers is also possible. In fact, it is this type of radiation that is most likely to be coupled into nearby I/O and power cables of the CWR6850. To locate the point or points of radiation, experiment with different cable arrangements to see if the RF-induced problem can be eliminated by reducing coupling between any of the CWR6850 cables and nearby coaxial lines carrying RF power. Figure 8A shows several cable arrangements, both good and bad, showing how to keep RF coupling to a minimum. Figure 8B shows how to use high- $\mu$  (950 - 2000) ferrite toroids or rods to choke the flow of RF on audio and control lines.

If cable rearrangement doesn't yield positive results, then begin eliminating pieces of equipment and sections of coaxial cable until the transmitter is connected directly to a shielded dummy load. As each piece of equipment is removed from the transmission line, check to see if the RF-related problems have diminished or disappeared. If the RF problem persists with the exciter connected directly to a dummy load, reduce the drive level to see if that eliminates the problem.

If operation into a dummy load does not significantly reduce the RF-related problems, disconnect all I/O cables from the CWR6850. Test the operation while it is connected only to AC power. At the same time, enable the transmitter so that it sends a CW signal into a dummy load. If RF problems are still present, then RF energy is probably being introduced to the CWR6850 through the power cord by way of the common AC mains power line. This is usually indicative of poor AC-line filtering in the radio transmitter power supply section. Figure 9A shows a common by-pass filter method used in many transmitters. Figure 9B shows a "brute-force" AC line filter that can be added to the transmitter or other equipment to eliminate the flow of RF on the AC power line.

In addition to the liberal use of RF by-passing capacitors on station equipment, the use of certain antennas may offer reduced levels of RF in the radio room in many cases. Whenever possible, use RESONANT dipole, vertical, quad, or Yagi antennas and try to achieve a good impedance match AT THE ANTENNA instead of relying on an antenna tuner. Random-length wire antennas and others that require extensive antenna tuning are more likely to create high levels of RF within the vicinity of the operating position.

The location of the transmitting antenna with respect to the radio room also has an effect on the RF energy that is coupled into interconnecting cables. Apartment dwellers may have the most difficulty achieving a good installation since many times an indoor antenna is the only type allowed. Where outdoor antennas are allowed, they should be placed as high as practical. Not only will this provide for better reception and transmission, but it will also reduce the level of RF in the shack. Also, if possible, avoid bringing an end of a half-wave dipole in close proximity to the operating position; there is a high voltage field at the ends of the dipole that may be hard to shield.

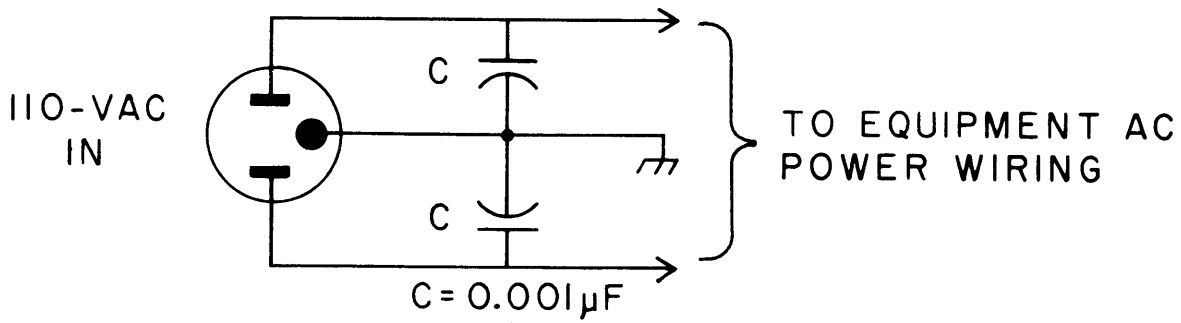

(A)

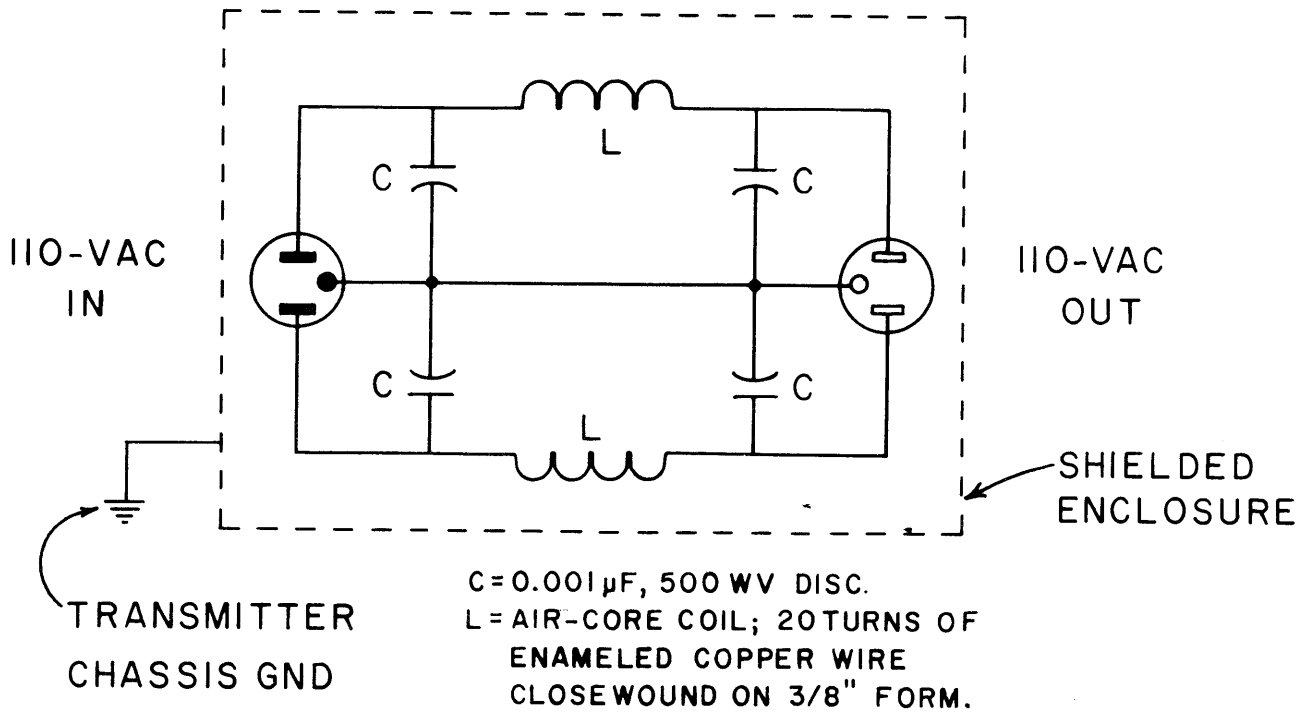

(B)

Figure 9. RFI Power Line Filters

In general, a shielded, coaxial cable feedline with low SWR is much preferred over open wire, twin-lead, or single wire feed systems. The self-shielding property and lower voltages present act to make the coaxial feedline much less susceptible to radiation of RF energy in the shack rather than at the antenna. RF energy may also be conducted back to the station by conduction down the outside of the coaxial cable shield. This may be a particular problem with half-wave dipoles on 40 and 80 meters that are center-fed with only coaxial cable. A balun at the antenna tends to reduce this problem. Also, dress the coaxial cable from the balun so that it drops perpendicular to the dipole, rather than parallel. In stubborn cases, you may find that dropping the coaxial cable clear to the ground and burying it (5 or 6 inches) for the horizontal run to the shack may help reduce RF coupling considerably. This technique has worked particularly well for second-story station installations. As an alternate to the balun, construction of an RF choke out of the Coax itself is sometimes effective; wind six or more turns of the coaxial cable in a six inch diameter coil. Place the coil at the antenna and wrap it with electrical tape to hold its shape. If there is a moderate to high SWR on the line (2:1 or more), you may find that varying the length of the line helps, although this is a poor substitute for a properly matched antenna.

Experience has shown that the TV monitor itself may be a source or conductor of RF interference. Various circuits of the TV monitor (particularly the sweep circuits) can and do generate RF interference which may be heard in the receiver. Also, the video output to the monitor is a widebandwidth digital signal with rich harmonic content as is required to produce the crisp character display. If the TV set is poorly shielded (not at all in some plastic-cabinet models) or lacks proper power line by-passing, the RF from the monitor's circuits or from the video output may escape to cause receiver interference. Also, RF from the transmitter may enter the monitor and disrupt the monitor or CWR6850 operation. This may be quickly tested by simply disconnecting the video cable from the CWR6850. There is no substitute for good shielding and by-passing; metal cabinet monitors are highly recommended!

When the CWR6850 is used in a mobile or portable installation, trouble may be experienced from transients caused by the battery-charging system. These transients may be minimized by connecting the CWR6850 power cord directly to the storage battery terminals, avoiding connections to the vehicle's DC terminal block. Any voltage drop between the battery and terminal block may also include the transient spikes. It may be necessary to install additional filtering on the DC leads to the CWR6850 and some on automotive accessories (such as blower and wiper motors) to eliminate such problems. Consult the ARRL Radio Amateur's Handbook for more information.



The CWR6850 has been tested and is verified by HAL Communications Corp. to be in compliance with Part 15, Subpart J of the FCC Rules And Regulations, Class B computing device. The following text is a requirement of that regulation:

"This equipment generates and uses radio frequency energy and if not installed and used properly, that is, in strict accordance with the manufacturer's instructions, may cause interference to radio and television reception. It has been type tested and found to comply with the limits for a Class B computing device in accordance with the specifications in Subpart J of Part 15 of FCC Rules, which are designed to provide reasonable protection against such interference in a residential installation. However, there is no guarantee that interference will not occur in a particular installation. If this equipment does cause interference to radio or television reception, which can be determined by turning the equipment off and on, the user is encouraged to try to correct the interference by one or more of the following measures:

- reorient the receiving antenna
- relocate the computer with respect to the receiver
- move the computer away from the receiver
- plug the computer into a different outlet so that computer and receiver are on different branch circuits.

If necessary, the user should consult the dealer or an experienced radio/television technician for additional suggestions. The user may find the following booklet prepared by the Federal Communications Commission helpful:

"How to Identify and Resolve Radio-TV Interference Problems."  
This booklet is available from the US Government Printing Office, Washington, DC 20402, Stock No. 004-000-00345-4."

In addition, the following rear-panel label is located on the CWR6850 rear panel:

"This equipment has been tested and found to comply with the technical specifications in Part 15 of FCC Rules for a Class B computing device."

Also, the following FCC text applies to use of peripherals attached to the CWR6850:

"WARNING: This equipment has been verified to comply with the limits for a Class B computing device, pursuant to Subpart J of Part 15 of FCC Rules. Only peripherals (computer input/output devices, terminals, printers, etc.) certified to comply with the Class B limits may be attached to this computer. Operation with non-certified peripherals is likely to result in interference to radio and TV reception."

## CHAPTER 6

## IN CASE OF DIFFICULTY

This section of your user's manual will discuss in general terms how to keep your CWR6850 in top operating condition and typical operating problems you might encounter (and some solutions). Circuit description, repair procedures, and schematic diagrams are included in the separate CWR6850 CUSTOMER MAINTENANCE MANUAL, available separately from HAL Communications Corp. or its dealers.

## 6.1 Care and Feeding of Your CWR6850

Your CWR6850 is the latest of many generations of terminals sold by HAL Communications. In every way, it has been designed, constructed, and tested to assure years of trouble-free operation. However, there are a number of simple procedures that you, the user, can follow to further improve the reliability, performance, and lifetime of the terminal. The following suggestions are offered to help preserve a long operating life for your CWR6850.

## Environment:

Electric equipment is very susceptible to variations in temperature, relative humidity, and to dust and dirt accumulations. The CWR6850 will operate in normal room-temperature environments and should be as tolerant of temperature extremes as you are while operating it. However, inadvertent blockage of the ventilating holes in the cabinet will cause the INTERNAL temperature of the terminal to rise considerably above the ambient room temperature and may in fact cause circuit failure. Also, accumulations of dust or dirt, particularly when accompanied by high humidity conditions, can also cause overheating and may result in long-term corrosion of the internal circuitry. Therefore, try to position the terminal so that its ventilating holes are not obstructed and try to avoid extremely dusty or dirty environments. On the other hand, the solid-state components in the CWR6850 are designed to operate at considerably higher temperatures than we humans; do not be overly disturbed if the cabinet of the CWR6850 (particularly the rear panel) operates quite warm to the touch. This internal heat often helps to "dry-out" humidity in the cabinet.

In the normal course of operation, the terminal and its display may attract a build-up of dust or smoke "haze". This may be expected even in the cleanest areas, particularly if tobacco smoking is prevalent. The display screen, because of the air flow around it and the high voltage applied to the CRT, actually attracts particulate matter from the air. This causes over a period of time what may appear to be a gradual fading of the screen intensity as well as de-focusing of the characters. Therefore, the face of the CRT should be cleaned often.

Be careful when cleaning any plastic parts as they scratch easily! Cleaning materials available for phonograph records are usually excellent for cleaning plastic, but may not be strong enough to do the job if too much dirt has accumulated.

The keyswitches in an electronic keyboard seem to be particularly vulnerable to humidity and particulate air contaminants. Experience has shown that keyswitch failures are considerably more likely in equipment used in a high humidity location (in a basement, for example); even more so if the basement operator also smokes! The keyswitches in the keyboard are commercial quality switches that should last for many years. However, they are essentially mechanical parts, unsealed from the environment and will tend to be much more susceptible to this type of problem than any other CWR6850 part.

#### Electrical Connection:

All electrical connection points of the CWR6850 have maximum voltage and current ratings as given in this manual. If these ratings are exceeded for even a short period of time, considerable damage to the terminal may result. Therefore, be very careful -- KNOW the ratings of the CWR6850 and the characteristics of any other equipment before making connections. Some common causes of electrical failures have been found to be:

- A. Inadequate grounding, causing RF interference problems as well as sensitivity to AC power line transients.
- B. Damage from lightning, or other transients on the power line or station antenna system. A good lightning protection system may help, as will disconnecting the terminal during electrical storms. However, such things are unpredictable and the CWR6850 is no more susceptible to such problems than other electronic equipment in the station.
- C. Improper connections to high voltage devices or to equipment with inadequate safety grounds. The CWR6850 does NOT include a high-voltage RTTY loop keying circuit and NONE of its rear panel jacks should be connected to high voltage loop circuits without the use of isolation devices such as optical isolators or relays. Be sure that all devices plugged into the AC mains have safety grounds attached to them. AC line by-pass capacitors in a piece of equipment may cause the cabinet of that equipment to "float" at an AC potential sufficiently high that damage might be done to the CWR6850 when the equipment is connected. **CONNECT THE GROUNDS FIRST - THEN CONNECT TO POWER!**

## 6.2 Typical Operational Problems

Because a large number of features are offered in the CWR6850, it is by nature a complicated device. Therefore, there may be times when it first appears that the terminal has either quit completely or gone off to "do its own thing". If some of the circuitry has failed, you may well get such symptoms. However, most often when a new owner finds the terminal "unresponsive", it is actually doing what it has been instructed to do. Familiarity with the CWR6850 controls will quickly reduce the chances of "cockpit error" during terminal operation.

The status line and front panel switch position are the best keys to what is happening in the CWR6850. Often, mistyping one key for another may cause a result entirely different from that intended. Some of the more confusing conditions you may encounter are:

1. Forgetting to terminate the programming of a HERE IS message with the RUB OUT key. If you forget to end the HERE IS programming, further typed text will continue to be entered into the HERE IS memory until all 64 memory locations are full. At this point, further typing is not accepted by the CWR6850 and it appears to be in a non-functioning condition. LOOK AT THE STATUS LINE! The "W1" next to the reverse video page "3" shows that the terminal is in write mode for HERE IS 1. Look at the displayed text in HERE IS 1, use the BS key to delete the extra characters you have typed, and end the HERE IS programming with the RUB OUT key. The "W1" will now disappear, the original display page will return to the screen, and the CWR6850 will function correctly.
2. The transmit buffer area of the screen will register the presence of a carriage control character (CR or LF), but will NOT perform the operation on this section of the screen; a LF will not shift the keyboard entry point to the next displayed line of the transmit buffer. The appropriate characters will be transmitted, however, in the sequence in which they were entered and the operations do appear in the RECEIVE section of the screen as they are transmitted (half duplex operation only). The transmit buffer display area is strictly linear, showing each key typed.
3. Wh2n word mode (CTRL-Y) and automatic control (CTRL-A) are used, the transmitter will turn on and off between words after the pre-typed text has been transmitted. This may cause loss of characters at the receiving station (particularly if a repeater is used). Use CTRL-X and continuous mode if this is a problem.
4. The CWR6850 may be operated in either half or full duplex modes as explained in section 4.7. However, transmitted text is ONLY "echoed" in the receive section of the display in half duplex.

5. The CWR6850 will only receive correctly if ALL the switches are set correctly. Refer to Chapter 3 for correct starting points for switch selection. The following are general guidelines:
- a. CW RECEIVE:
    - CW/RTTY - button out
    - RX/TAPE - button out
    - SEND/RECEIVE - RECEIVE or AUTO (CTRL-X off)
  - b. RTTY RECEIVE:
    - CW/RTTY - button in
    - ASCII/BAUDOT - select code (BAUDOT, usually)
    - LOCK-UOS ON - ON (button in)
    - NOR/REV - NOR (button out; if LSB used)
    - BAUD - select rate (45.5, usually)
    - SHIFT - select shift (170, usually)
    - TONE - high for VHF; either for HF
    - RX/TAPE - RX (button out)
    - SEND/RECEIVE - RECEIVE
    - FINE - "0" (center detent)
6. Look at the status line. The presence of one or more letters on this line indicates that a feature has been activated by the corresponding control command. A complete list of the control commands, their action, and the corresponding status indicator is shown in Chapter 7. Often, a confusing state may have been caused by accidental typing of a control command. Above all, be careful when using the "CTRL-L:RETURN" key sequence. If invoked, the CWR6850 is expecting to load the HERE IS memories from tape. The ONLY recovery is to load from the tape or cycle the power on and off! See section 4.3 for further information. The "CTRL-S:RETURN" tape save command will likewise yield confusing results, but will recover after the total contents of all six HERE IS memories have been transmitted.
7. The RESET button will clear the entire receive display area, clear the printer output buffer, and clear the tape save buffer. Use this control carefully, but in preference to cycling the power off and back on.

### 6.3 Repair Procedures

In the event that your CWR6850 develops a malfunction, the first step is to carefully note all of the symptoms of the problem. Statements such as "BROKEN" or "DOESN'T WORK" are of little help to the service technician, and usually lead to longer repair times than might otherwise be required. Try to provide as much information concerning the failure as you can before you contact your dealer. By all means, consult your dealer before calling the factory; he may be able to fix the unit locally and avoid the shipping and delay times.

The following are some of the things that will concern the dealer or factory:

1. Model number
2. Serial number
3. How long have you owned it?
4. Where did you purchase it (dealer's name)?
5. If purchased used, who was the previous owner? (Used to refer to any previous repair history on that unit.)
6. What terminal modes, rates, codes, and conditions are associated with the failure? Does it happen only in receive, transmit, or both?
7. Are there extenuating circumstances? (Lightning, spilled liquids, dropped unit?)
8. Is the problem confined to a particular unit? (CWR6850, keyboard?)
9. Is there anything else you can add to the description that you think might be useful?

AFTER you have determined answers to the above, contact your dealer and discuss the problem with him. If he indicates that he will be unable to assist you, the unit should be returned to the HAL factory for repair. Before returning the unit to the factory, either you or the dealer should call and receive factory return authorization so that we may expect the unit in shipping and be prepared to work on it when it arrives. When2ver possible, return the unit via UPS to the factory address below, insuring it for the full value. The shipping cost to the factory should be paid by you; the return shipping costs from the factory (48 contiguous states only) are paid by HAL (warranty repairs only). The factory "ship-to" address is:

HAL COMMUNICATIONS CORP  
1201 W. KENYON ROAD  
BOX 365  
URBANA, ILLINOIS 61801  
ATTENTION: REPAIR DEPARTMENT

The one-year limited warranty (listed in full at the end of this manual) provides for repair of the CWR6850 for a full year after purchase. The purchase invoice date from your dealer marks the beginning of the warranty period - save your copy of the invoice! Please read the warranty carefully to determine the full extent of the privileges and limitations.

#### 6.4 User Adjustments

Because of the complexity of the circuitry used in the CWR6850, we do NOT recommend that you personally undertake repairs of the terminal circuit boards. However, there are a number of alignment procedures that you may undertake if you have the test equipment available. DO NOT UNDERTAKE ANY ADJUSTMENTS UNTIL YOU ARE SURE THAT UNDERSTAND THE ENTIRE PROCEDURE! If in doubt, don't do it! (Ask your dealer or the factory for help.) The recommended minimum test equipment is:

1. Audio Frequency Counter - high impedance input, 1 V or better sensitivity, count to 1 MHz or higher.
2. Audio Frequency Oscilloscope - high impedance input, 1 V or better sensitivity, 1 MHz or greater bandwidth.
3. Volt-Ohm-Milliammeter (VOM) - 20K ohms/volt or higher.
4. Audio Frequency Oscillator - 500 ohm impedance, 10 mV to 1 V rms output, 500 - 3000 Hz adjustable frequency.

Simplified layout drawings are shown in Figure 10 that give the locations of various variable resistors (VR-n), test points (TP-n), and user jumper locations (JP-n). Note that there are numerous additional jumper locations on the circuit boards that should not be disturbed from their factory settings.

There are four major sub-assemblies that make-up the CWR6850;

1. The cabinet with its controls, connectors, and wire harnesses.
2. The CRT display section.
3. The digital circuit board (top board).
4. The modem circuit board (bottom board).

Most of the following adjustments are located on one of the two circuit boards. It is NOT necessary to remove any circuit boards to make these adjustments. You will, however, have to remove both the top and bottom covers of the CWR6850. Be careful to avoid misplacing any of the sixteen black screws that fasten the covers in place - they are metric and not easily replaced! Use a good No. 2 Phillips screw driver (NOT No. 1 or smaller). The diagrams in Figure 10 show the boards AS VIEWED FROM THE FRONT PANEL.

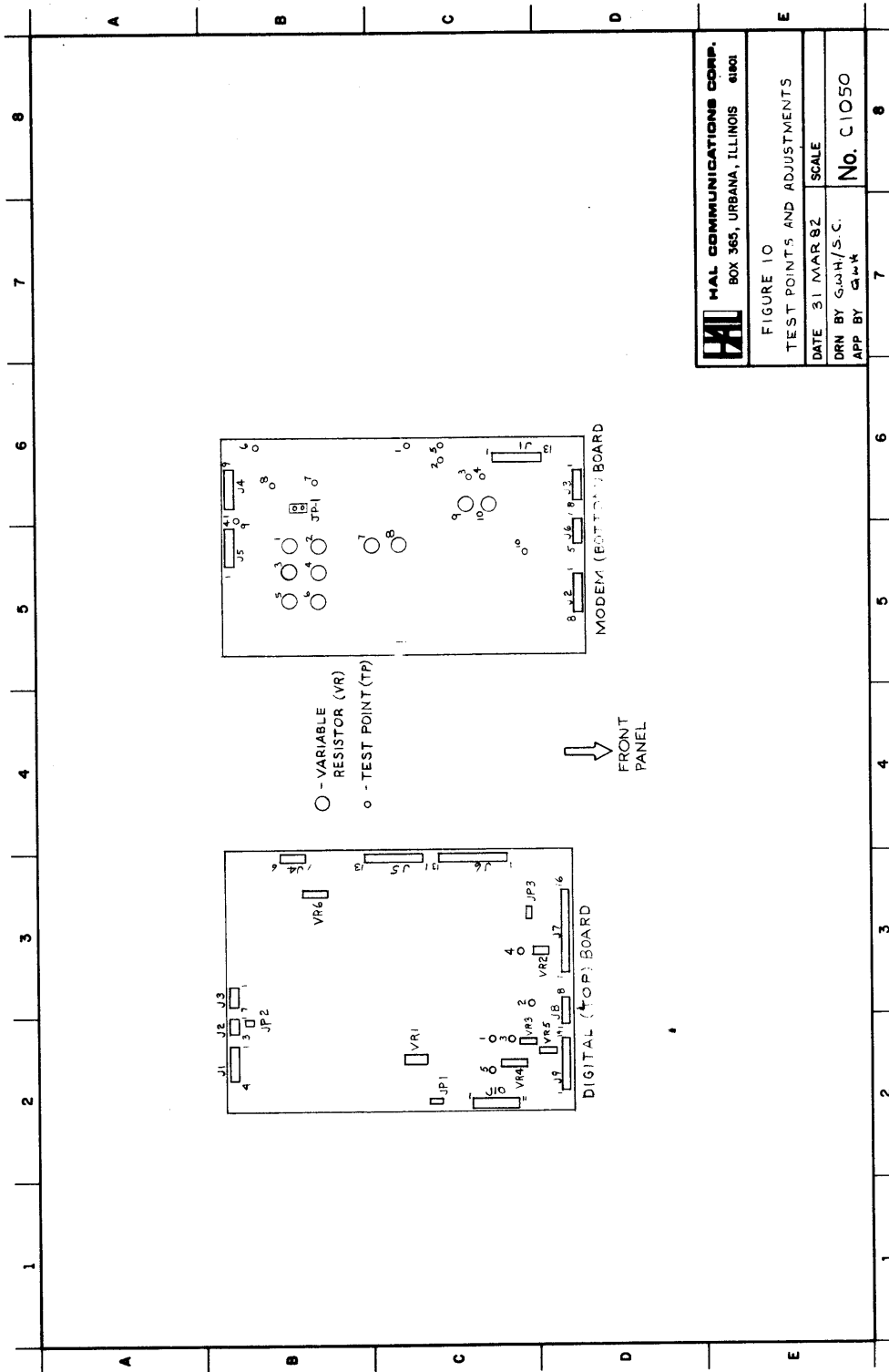

**HAI** HAL COMMUNICATIONS CORP.  
 BOX 365, URBANA, ILLINOIS 61801

FIGURE 10  
 TEST POINTS AND ADJUSTMENTS

DATE 31 MAR 82 SCALE  
 DRN BY GWH/S.C.  
 APP BY CLK No. C1050

Figure 10. Test Points and User-adjustable Controls



## CIRCUIT BOARD JUMPER FUNCTIONS

BOARD	JUMPER	JP OPEN CKT	JP SHORT CKT
MODEM (bottom)	JP-1	Set Mark Tone	Set Space Tone
DIGITAL (top)	JP-1	SW OUT FSK: MARK = "ON"	SW OUT FSK: SPACE = "ON"
	JP-2	SW OUT CW: +/- CW Keying 0.8 V offset	SW OUT CW: +CW keying only 0.2 V offset

- NOTES:
1. JP is used to align the transmit AFSK tones; use clip to chassis ground from pin at JP.
  2. Use "solder-bridge" to "short" JP-1 & JP-2.

## ADJUSTMENTS AND MEASUREMENTS ON DIGITAL (TOP) BOARD:

CONTROL/TP	ACTION
VR-1	Adjusts frequency of CW sidetone oscillator; set to 800 Hz at TP-1 AFTER ADJUSTING VR-2.
VR-2	Adjust center frequency of CW PLL filter; ADJUST BEFORE VR-1. With no signal input, set VR-2 for 800 Hz at TP-2.
VR-3	Adjust minimum CW transmit speed. Set SPEED slide control to minimum (0) and adjust VR-3 for CW transmit speed desired. (Measured at TP-3)
VR-4	Adjust maximum CW transmit speed. Set SPEED slide control to maximum (10) and adjust VR-4 for CW transmit speed desired. (Measured at TP-3)
VR-5	Adjusts center frequency of CW active filter. Feed 10-20 mV, 800 Hz signal into AF input, adjust VR-5 for maximum signal at TP-5 (use oscilloscope).
VR-6	Adjust contrast of the internal CRT display.
TP-6	Measure CW transmit speed; CW WPM = 2.667 x freq.

## ADJUSTMENTS AND MEASUREMENTS ON MODEM (BOTTOM) BOARD:

## 1. SET RECEIVE RTTY FILTERS:

Set-up as follows:

1. SEND-AUTO-RECEIVE to SEND
2. RX-TAPE to TAPE
3. Connect AFSK OUT-TAPE to AF IN-TAPE
4. SHIFT slide control to "0" (center detent)
5. AFSK GAIN control fully clockwise
6. Connect oscilloscope to TP-3 or TP-4 as indicated.
7. Open or short JP-1 as indicated.

TONE	SHIFT SWITCH	TEST POINT	JP-1	ADJ FOR MAXIMUM
HIGH	any	TP-3	OPEN	VR-7
	170	TP-4	SHORT	VR-1
	425	TP-4	SHORT	VR-2
	850	TP-4	SHORT	VR-3
LOW	any	TP-3	OPEN	VR-8
	170	TP-4	SHORT	VR-4
	425	TP-4	SHORT	VR-5
	850	TP-4	SHORT	VR-6

VR-9 and VR-10 are used to adjust the amplitude balance between the mark and space receive channels. They should NOT require re-adjustment!

## 2. OTHER USER ADJUSTMENTS:

The only remaining user-adjustable controls are those in the CRT monitor sub-assembly. The functions of these controls are clearly marked on the circuit board and you may adjust them if required. The available controls are:

MARKING	LOCATION	FUNCTION
V-LIN	Right side	Adjust vertical linearity
V-HEIGHT	Right side	Adjust vertical height
V-HOLD	Right side	Adjust vertical oscialltor frequency
VIDEO CENTER	Right side	Adjusts horizontal centering
SUB-BRIGHT	Right side	Adjust brightness of CRT
FOCUS	Right side	Adjust focus of display

These are the ONLY user-adjustable controls in the CWR6850. Please do attempt re-adjustment of any other controls or use of any jumpers not mentioned in the above discussion. If your CWR6850 still exhibits problems or cannot be adjusted as explained, please contact your dealer or the factory for more information.

CHAPTER 7  
SPECIFICATIONS

## INPUT/OUTPUT:

AUDIO INPUT: 30 mV to 2 V rms, 8 ohm audio  
800 Hz for Morse receive  
1000-3000 Hz for RTTY

AUDIO OUTPUT: XMIT OUT = 25 mV nom, 500 ohms (adj.)  
TAPE OUT = 25 mV nom, 500 ohms (adj.)  
EXT.SP = adj. to 2 Watts, 8 ohms

TTL I/O: (FSK TTL) Standard TTL data interface levels;  
Mark = +2.7 V  
Space = +0.6 V (= CW key down)

MORSE KEY: (SW.OUT-CW) Transistor switches to key + or - circuits  
Voltage = + or - 100 VDC maximum  
Current = 100 mA (+V); 10 mA (-V) maximum

SCOPE OUTPUTS: (OSCILLO) Separate mark and space connections for crossed  
ellipse indication on X-Y scope display.  
Voltage = 1.0 V p-p typical, 200K ohms

ASCII PRINTER: Parallel, Centronics - compatible printer output.  
Received and transmitted text may be printed on the  
ASCII printer, regardless of code.

KOS SWITCH: (SW.OUT-REMOTE) NPN transistor switch to ground to control TX/RX  
function of station. ("SW.OUT - REMOTE")  
Voltage = 50 +VDC maximum  
Current = 200 mA maximum  
Isolation relay or circuit required to switch neg-  
ative voltage control lines.

FSK OUT: (SW.OUT-FSK) NPN transistor switch to ground to switch direct  
FSK keying circuit ("SW.OUT - FSK")  
Voltage = 100 +VDC maximum  
Current = 100 mA maximum  
Standard: "ON" = space; "OFF" = mark; may be rev-  
ersed with internal jumper JP-1.

KEYBOARD; Connection to accessory keyboard.

VIDEO OUT: RS170 standard composite video output;  
1.0 V p-p, 72 ohms.

## DATA CODES AND RATES:

**BAUDOT CODE:** U.S. Standard 5-level International Telegraphic Alphabet No. 2 Baudot Code with 1 unit start and 1.5 unit stop bit (CCITT No. 2).

**ASCII CODE:** American National Standard Code for Information Interchange (ASCII) as defined by ANSI Standard X3.4-1968. 8 unit code with 1 unit start pulse; 2 unit stop pulse (ISO/CCITT No. 5).

**RTTY DATA RATES:** Baudot or ASCII codes may be transmitted and received at 45.45, 50, 56.88, 74.2, 110, and 300 baud.

**MORSE CODE:** Continental Morse Code including all letters, numbers, period, comma, colon, dash, apostrophe, parentheses, quote, question mark, and AA, AR, AS, BT, BT, KN, SK, and error prosigns. Receive speed automatically tracks from 1 to 100 wpm speeds; transmit speed may be set for 4 to 33 wpm.

## MODEMS:

**MORSE:** AF Active filter or Phase-lock loop filter; 800 Hz nominal center frequency.

**RTTY HIGH TONES:** Mark = 2125 Hz  
Space = 2295 Hz (170 Shift)  
= 2550 Hz (425 Shift)  
= 2975 Hz (850 Shift)  
CW ID = Space tone (all shifts)

**RTTY LOW TONES:** Mark = 1275 Hz (170 Shift)  
Space = 1445 Hz (170 Shift)  
= 1700 Hz (425 Shift)  
= 2125 Hz (850 Shift)  
CW ID = Space tone (all shifts)

Transmit audio tone frequencies are automatically set to correspond to selected modem and shift; NORM/REV switch changes polarity of RX tones only.

## DISPLAY:

**SCREEN:** 5 inch diagonal measur2 (3.25" x 4.26") green CRT; 20 lines of 32 characters per line; four pages may be selected for viewing.

**PAGE MEMORY:** 56 lines of 32 characters per line (4 pages); 25 lines of receive text, 15 lines of pretype transmit text; 12 lines of memory channel storage.

**CHARACTERS:** Full upper and lower case letters, all numbers and punctuation of the ASCII character set, special graphic symbols for ASCII control codes; 5 x 7 dot matrix; green characters on a dark background.

**SCROLL:** Received text is displayed on bottom line of receive area of screen; new text scrolls upward.

**TX/RX CONTROL:** Automatic Keyboard Operated Switch (KOS) or manual keyboard or manual front panel switch control of station transmit-receive circuitry (+ voltage).

**INDICATORS:**

**LED:** Four LED indicators show MARK, SPACE, Morse center tuning (CW), and Power indicator.

**SCREEN:** One line of screen shows which CTRL- functions are presently in use; contents of all HERE IS messages are displayed on page 3. (See APPENDIX B)

**SCOPE:** Rear panel connections to vertical and horizontal amplifier inputs of an X-Y oscilloscope for conventional crossed-loop indication (Oscilloscope NOT included with CWR6850).

**KEYBOARD:** 55 keys plus space bar, ASCII keyboard arrangement. RUB OUT allows back-up error correction.

**MESSAGE STORAGE:** Six, 64-character user-programmable HERE IS texts. (HERE IS) CW ID may be included within HERE IS 0 text.

**FRONT PANEL CONTROLS:**

**SLIDE CONTROLS:**

**INPUT:** Volume control for received signals.

**VOLUME:** Volume control to monitor CW sidetone and RTTY transmit tones.

**SPEED:** CW transmit speed adjustment.

**FINE:** Fine tuning of RTTY space filter center frequency; detent for optimum.

**LEVER SWITCHES:**

**POWER:** CWR6850 DC power switch.

**SEND-AUTO-RECEIVE:** SEND: The transceiver and CWR6850 are set to transmit continuously

AUTO: The transceiver and CWR6850 TX/RX condition may be set by keyboard commands.

RECEIVE: The transceiver and CWR6850 are set to receive continuously

PUSHBUTTON SWITCHES	RESET ON	Erase receive screen, return cursor to initial receive position, display 1st display page. Clear printer output register and erase memory transmission buffer.
	FILTER ON	Turns on CW PLL tracking filter; gives narrow bandwidth CW receive response.
	SPACE- NARROW	Reduces CW reception interpretation time of word spacing by 25%.
	CWID A- CWID B	CWID A: Transmit CW ID on SW-OUT CW, FSK, and 800 Hz tone. CWID B: Transmit CW ID using AFSK, mark-space RTTY tones.
	DISPLAY	PAGE: Cyle display pages on screen. MODE A: Page cycles between pages 0 and 1; used for receive only. MODE B: Page cycles through all four pages; used for TX/RX.
	CW - RTTY:	Selects between CW (Morse code) and RTTY (Baudot or ASCII) codes.
	ASCII- BAUDOT	Selects between the ASCII (8 unit) and BAUDOT (5 unit) RTTY codes.
	LTR ON	Restores Baudot receive to LTRS case.
	FIG ON	Restores Baudot receive to FIGS case.
	LOCK / UOS ON	In Baudot gives return to LTRS case after reception of a space character. In ASCII locks receive and transmit characters to upper case only.
	NOR - REV	Reverses the sense of received signals - does not change sense of transmitted tones.
	BAUD	Six interlocked switches set data rate for RTTY transmit and receive to: 45.45, 50.0, 56.9, 74.2, 110, 300 baud
	SHIFT	Three interlocked switches set RTTY transmit and receive shift to 170, 425 or 850 Hz.
	TONE	HIGH: Select RTTY "HIGH" tones for transmit and receive; mark = 2125 Hz. LOW: Select RTTY "LOW" tones for transmit and receive; mark = 1275 Hz.
	RX - TAPE	RX: Audio signal connected to AF IN - RX jack is interpreted by the CW and RTTY demodulators. TAPE: Audio signal connected to AF IN - TAPE jack is interpreted by the CW and RTTY demodulators. Local "echo" of transmitted data is suppressed, giving full duplex operation.

REAR PANEL CONNECTIONS: KEY BOARD, PRINTER, VIDEO OUT, EXT SP, PHONE, TELEGRAPH KEY, FSK TTL IN, FSK TTL OUT, AF OUT, SW OUT REMOTE, SW OUT FSK, SW OUT CW, OSCILLO SPACE, OSCILLO MARK, AFSK OUT TX, AFSK OUT TAPE, AF IN TAPE, AF IN RX, FUSE, DC 13.8V.

REAR PANEL CONTROLS: FSK DEMOD: INT: Internal FSK demodulator used for reception of RTTY.  
EXT: Internal FSK demodulator disconnected and received data interpreted from the FSK TTL IN connector.

AFSK GAIN: Controls output level to both AFSK OUT - TX and - TAPE connectors.

BRIGHT: Controls contrast of internal screen.

MECHANICAL SPECIFICATIONS:

CWR6850: 12.7"W x 5.0"H x 12.5"D (13.25x5.1x14 clearance)  
32.26cm x 12.7cm x 31.75cm (33.66x12.95x35.56 clr)  
Color: Dark gray top and bottom; black front panel; red, blue, gray, white, and black switch buttons. Green CRT phosphor.

KEYBOARD: 13.8"W x 2.3"H x 7.1"D  
35.05cm x 5.84cm x 18.03cm  
Color: Light gray top; dark gray bottom; blue and gray keytops.

WEIGHTS: 16.5 lbs net, 20 lbs shipping (including keyboard)  
7.5 kg net, 9.1 kg shipping (including keyboard)

POWER: 12 to 14.5 VDC (13.8 VDC nominal), 1.65 Amps.  
22 Watts

APPENDIX A  
CWR6850 KEYBOARD CONTROL COMMAND LIST

CONTROL KEY	STATUS INDICATOR	FUNCTION
CTRL-A	A	On - off control of automatic transmit-receive operation; SEND-AUTO-RECEIVE switch must be in AUTO position.
CTRL-C	C	On - off control of reception and transfer to the printer of ASCII control codes.
CTRL-D	D	Extends CW transmit dash length by 25%, reducing the effective CW "weight".
CTRL-E	E	On - off control of echo-back from transmit to receive buffer areas.
CTRL-G		Inserts signal bell code in transmit buffer; effective only in ASCII and Baudot.
CTRL-I		Changes transmit mode from RTTY to CW for all text to be transmitted. Shows reverse video star (*) in receive buffer.
CTRL-L:RETURN	L	Load start command to load contents of all six HERE IS memories from tape; control passes to tape and CWR6850 will not respond to further keyboard commands until after an ASCII STX character is received from tape.
CTRL-N		In Baudot, inserts FIGS character in transmit buffer; in ASCII inserts SO. No effect in CW.
CTRL-O		In Baudot, inserts LTRS character in transmit buffer; in ASCII inserts SI. No effect in CW.
CTRL-P	P	On - off control of the printer.
CTRL-Q:0	Q	Set display to page 0
CTRL-Q:1	Q	Set display to page 1
CTRL-Q:2	Q	Set display to page 2
CTRL-Q:3	Q	Set display to page 3
CTRL-Q:other		Set display to original display page.



CTRL-R:0	R	Read contents of HERE IS 0 for transmission
CTRL-R:1	R	Read contents of HERE IS 1 for transmission
CTRL-R:2	R	Read contents of HERE IS 2 for transmission
CTRL-R:3	R	Read contents of HERE IS 3 for transmission
CTRL-R:4	R	Read contents of HERE IS 4 for transmission
CTRL-R:5	R	Read contents of HERE IS 5 for transmission
CTRL-R:other		Reset CTRL-R command
CTRL-S:RETURN	S	Transmit contents of all 6 HERE IS messages to tape recorder for storage.
CTRL-U	U	RTTY transmit speed is slowed to 25-baud equivalent speed by increasing the length of the stop pulse. The baud rate of the character itself is not changed from that set by the BAUD switch.
CTRL-W:0	W	Program HERE IS #0; end with RUB OUT key.
CTRL-W:1	W	Program HERE IS #1; end with RUB OUT key.
CTRL-W:2	W	Program HERE IS #2; end with RUB OUT key.
CTRL-W:3	W	Program HERE IS #3; end with RUB OUT key.
CTRL-W:4	W	Program HERE IS #4; end with RUB OUT key.
CTRL-W:5	W	Program HERE IS #5; end with RUB OUT key.
CTRL-W:other		Cancel CTRL-W command.
CTRL-X	X	Turn on transmitter and transmit data; works when SEND-AUTO-RECEIVE switch is in AUTO; transmitter stays on until second CTRL-X is used to turn transmitter off.
CTRL-Y	Y	On - off control of word mode transmission.
CTRL-Z:BS	Z	Deletes final line in transmit buffer area; repeated BS operation deletes preceding line without further need of CTRL-Z.
CTRL-Z:SHIFT-\	Z	Deletes all text in transmit buffer.
CTRL-Z:SHIFT-*	Z	On - off control of insertion of CW text in stream of otherwise RTTY in transmit buffer
CTRL-^	^	Turns on sync-idle; stops sending transmit text until turned off with 2nd CTRL-^.
CTRL-@		Inserts NUL code in transmit buffer in ASCII; BLANK code in Baudot. No effect in CW.

APPENDIX B  
CWR6850 DISPLAY FORMAT

TOTAL DISPLAY CAPABILITY:

LINE NO.	DISPLAY CONTENT	
1	..... (blank).....	☐ — (page 0 shown)
2	.....	
3	.....	
4	.....	
5	.....	
6	.....	
7	.....	
8	.....	
9	.....	
10	.....	PAGE 0
11	.....	
12	...Receive Text Display Area....	.....
13	.....(Lines 2-27).....	
14	...26 Lines, 832 Characters.....	
15	.....	
16	.....	
17	.....	
18	.....	
19	.....	
20	.....	
21	.....	PAGE 1
22	.....	
23	.....	
24	.....	
25	☐...Receive cursor starts here..	
26	.....	
27	.....	
28	..Tape Store Output Buffer.....	
29	.....Status Indicators.....	☐ — (page 1,2,3 shown)
30	.....	
31	.....	
32	.....	
33	.....	
34	.....	PAGE 2
35	.....	
36	...Transmit Buffer Area.....	
37	.....Lines 30 - 44.....	
38	...15 Lines, 480 Characters....	
39	.....	
40	.....	
41	.....	
42	.....	
43	.....	
44	.....	
45	.....HERE IS 0.....	
46	.....(Lines 45-46).....	
47	.....HERE IS 1.....	
48	.....(Lines 47-48).....	
49	.....HERE IS 2.....	
50	.....(Lines 49-50).....	
51	.....HERE IS 3.....	
52	.....(Lines 51-52).....	
53	.....HERE IS 4.....	
54	.....(Lines 53-54).....	
55	.....HERE IS 5.....	
56	.....(Lines 55-56).....	

PAGE 3  
(lower  
8  
lines)

PAGE 3  
(Upper  
12  
lines)

PAGE 0 AND PAGE 1 DISPLAY FORMAT:

PAGE 0

LINE NO	DISPLAY CONTENT
1	.....Blank..... <input type="checkbox"/> — (Page No.)
2	.....
3	.....
4	.....
5	...Top Portion of Receive.....
6	.....Display.....
7	..(19 lines, 608 characters)....
8	.....
9	.....
10	.....
11	.....
12	.....
13	.....
14	.....
15	.....
16	.....
17	.....
18	.....
19	.....
20	.....

.....

|

Repeated

on

Page 1

|

.....

PAGE 1

LINE NO	DISPLAY CONTENTS
13	.....
14	.....
15	.....
16	.....
17	.....
18	.....
19	.....
20	...Bottom Portion of Receive....
21	.....Display.....
22	...15 Lines, 480 Characters.....
23	.....(Lines 13-27).....
24	.....
25	<input type="checkbox"/> .....
26	.....
27	.....
28	...Tape Store Output Buffer.....
29	....Status Indicators..... <input type="checkbox"/> — (Page No.)
30	....Top of Transmit Buffer.....
31	....3 Lines, 96 Characters.....
32	.....(Lines 30-32).....

.....

|

Repeated

from

Page 0

|

.....

Note: ONLY Page 0 and Page 1 are available in "MODE A"

PAGE 2 AND PAGE 3 DISPLAY FORMAT:

PAGE 2

LINE NO	DISPLAY CONTENTS
25	<input type="checkbox"/> ..Bottom of Receive Buffer.....
26	....3 Lines, 96 Characters.....
27	.....(Lines 25-27).....
28	...Tape Store Output Buffer.....
29	....Status Indicators..... <input type="checkbox"/> —(Page No.)
30	.....
31	.....
32	.....
33	.....
34	.....
35	.....
36	....All of Transmit Buffer.....
37	...15 Lines, 480 Characters.....
38	.....(Lines 30-44).....
39	.....
40	.....
41	.....
42	.....
43	.....
44	.....

PAGE 3

LINE NO	DISPLAY CONTENTS
45	.....HERE IS 0.....
46	.....(Lines 46,46).....
47	.....HERE IS 1.....
48	.....(Lines 47,48).....
49	.....HERE IS 2.....
50	.....(Lines 49,50).....
51	.....HERE IS 3.....
52	.....(Lines 51,52).....
53	.....HERE IS 4.....
54	.....(Lines 53,54).....
55	.....HERE IS 5.....
56	.....(Lines 55,56).....
25	<input type="checkbox"/> ..Bottom of Receive Buffer....
26	....3 Lines, 96 Characters.....
27	.....(Lines 25-27).....
28	...Tape Store Output Buffer.....
29	....Status Indicators..... <input type="checkbox"/> —(Page No.)
30	....Top of Transmit Buffer.....
31	....3 Lines, 96 Characters.....
32	.....(Lines 30-32).....

Note: "MODE B" must be selected to view Pages 1 and 2.

## LIMITED WARRANTY

HAL Communications Corp. of Urbana, Illinois, hereby warrants to the original retail purchaser only that the products herein described and sold shall be free from defects in materials and workmanship for a period of one year from the date of sale to the original retail purchaser.

In the event of a defect in materials or workmanship during the warranty period, HAL Communications Corp. will, at its own expense, repair the defective unit and replace any defective parts. Cost of shipping the unit to HAL Communications Corp. shall be paid by the purchaser, as well as costs of removal and reinstallation of the unit. HAL Communications Corp. will bear the shipping costs incurred in returning the unit to the purchaser (48 contiguous states only).

To obtain service under this warranty, the original purchaser should do the following:

1. Notify, as soon as possible, the Customer Service Department of the original selling dealer or HAL Communications Corp., Box 365, Urbana, Illinois, 61801, either in writing or by telephone, of the existence of a possible defect.
2. At the time of notification, identify the model and serial number, date of purchase, place of purchase, and the possible defect;
3. Hold the unit until a written return authorization is received.
4. Return the unit, freight prepaid, upon the receipt of the written return authorization with a copy of the original bill of sale for the equipment.

Correct installation, use, maintenance, and repair are essential for proper performance of this product. The purchaser should carefully read the technical manual.

This warranty does not apply to any defect which HAL Communications Corp. determines is due to any of the following:

1. Improper maintenance or repair, including the installation of parts or accessories that do not conform to the quality and specifications of the original parts;
2. Misuse, abuse, neglect, improper installation, or improper operation (including operation without a proper safety ground connection);
3. Accidental or intentional damage.







All implied warranties, if any, are limited in duration to a period of one year from the date of purchase by the original retail purchaser. (Some states do not allow limitations on how long an implied warranty lasts, so the above limitation may not apply to you.)

HAL Communications Corp. disclaims any liability for incidental or consequential damages arising out of the use of, or inability to use, this product. (Some states do not allow the exclusion or limitation of incidental or consequential damages, so the above limitation or exclusion may not apply to you.)

This warranty gives you specific legal rights, and you may also have other rights which vary from state to state.

## CWR6850 MANUAL ADDENDUM 1

The following additions apply to your CWR6850.

1. The command "CTRL-B" may be used to give a "break" transmit condition. The "break" command in RTTY gives continuous SPACE condition output until a second CTRL-B is typed. The "break" command in CW gives continuous "key-down" condition until a second CTRL-B is typed. The CTRL-B command may only be used when the SEND-AUTO-RECEIVE switch is in the SEND position. Activity of the "break" command is shown by the letter "B" in the status line.
2. The double vertical arrow symbol (  ) at the right-hand side of the status line is used to indicate that a command is waiting further input from the keyboard. Except for the ESC command, commands showing (  ) can be cancelled with the RUBOUT key. Also, the command will be cancelled if a key other than the proper response is typed (for example any key except RETURN after a CTRL-L). The exception is, of course, when CTRL-W is used to program the HERE IS messages; only the RUBOUT ends HERE IS programming.
3. An open (  ) or closed (  ) right-arrow on the status line shows that data input from the keyboard is not being accepted (such as during CTRL-L or CTRL-S operations). The arrow changes from open (  ) to closed (  ) when the operation is active. Only the RESET front panel switch may be used to cancel the right-arrow commands.
4. The CTRL-Q:n command is used to change the display page from the keyboard as explained on page 68 of the manual. When the CWR6850 is first turned on, the display is set to display page 1 on the screen; other pages may be set with the CTRL-Q:0, CTRL-Q:2, etc. commands. CTRL-Q:5 will reset the display back to page 1. The CTRL-Q:5 return page may be set to any other page with the following procedure: Use CTRL-Q:n to select the desired "default" display page and then type CTRL-Q:6. Now, the display will return to the new "default" page when CTRL-Q:5 is used.

5. The following precautions apply when using the CWR6850 with the ICOM brand of HF transceivers (IC710,720,720A,730):
  - a. When using SW-OUT FSK connection (see section 5.3 of the manual) to drive the direct FSK connection of the ICOM transceivers, it is necessary to invert the normal sense of the FSK output from mark = "on" to space = "on". To make this change, refer to section 6.4 of the manual and short-across jumper JP-1 on the digital board (top board). See Figure 10. for the location of JP-1. Refer to item (c) below for further considerations.
  - b. On the IC710 and IC720 (but NOT the IC720A), the FSK TTL OUT connection may be used in place of the SW-OUT FSK connection for direct FSK, subject to conditions listed in (c) below.
  - c. Measure the voltage at the FSK input terminal to the ICOM transceiver:
    - i. If a voltage larger than 5 volts is measured, use the SW-OUT FSK connection outlined in step (a) above.
    - ii. If no voltage is measured, use the FSK TTL OUT connection as discussed in step (b) above.
  - d. Do NOT use the audio signal on pin 4 of the ICOM accessory connector for audio output connection; connect the EXT-SP terminal of the ICOM to the AF IN RX connector of the CWR6850 instead.
  - e. Use the REV position of the NOR-REV switch of the CWR6850.
  - f. When transmitting CW, place a solder short across JP-2 on the digital board (top board) as explained in section 6.4 of the manual.
  - g. If problems are experienced with transmit-receive control of the ICOM transceiver by the CWR6850, it may be necessary to change the value of R50 on the digital board. R50 is located at the center rear of the circuit board and is presently a 1500 ohm resistor. Because of the high current relays used in the ICOM transceivers, it may be necessary to replace the 1500 ohm resistor with a 470 ohm resistor. This has not been found to a problem in our testing of the CWR6850, but may be present on some units due to ICOM production variations between units.
  
6. The special considerations for the ICOM brand of HF transceivers does not seem to apply to other manufacturer's brands of transceivers with the possible exception of the choice of audio output connection to the transceiver. ALWAYS use a low-impedance audio output such as the external speaker connection (or Kenwood phone patch output) rather than a high-impedance, low-level output (such as the TR7 auxilliary output).