

SECTION I

INTRODUCTION

1.1 PURPOSE

The purpose of this manual is to provide operating procedures and maintenance instructions for the Model 1280A Modem. Individual sections are devoted to installation, operation, theory of operation, preventive and corrective maintenance, and diagrams and parts lists.

1.2 GENERAL DESCRIPTION

The Model 1280A FSK Modem is microprocessor controlled. It is designed for use as a modem, a one or two channel modulator, or a one or two channel demodulator. It will accept input data of EIA-RS-232C, MIL-STD-188C, or high level (20 to 60 milliamps) loop current. It operates in the FSK* mode with shifts of 60 to 200 Hz and in the FSK mode with shifts from 60 to 5700 Hz (60 to 2700 Hz Bundespost). Baud rates are selectable to 1200. Operating parameters are entered by the front panel keypad (or a remote terminal) and displayed on the front panel plasma display.

The Modulator card(s) accepts high level current loop, EIA-RS-232 or MIL-STD-188C data in and modulates it at the frequencies selected. The Demodulator card(s) receives the keyed tones and demodulates them as determined by the selected parameters with a resulting data output of EIA-RS-232, MIL-STD-188C and optional high level current loop. The Control card serves as an interface between the keypad (or remote terminal) and the demodulator and modulator cards. The Control Board contains the high speed demodulator circuit with the standard configuration.

N O T E

The Demodulator Board D9087, Control Board D9084, and the Modulator Board D9096 make up the standard configuration. A dash one version (D9087-1 and D9084-1) is also available on special order.

* The modem offers true FSK as defined by FEC's U.S. Patent Number 4,317,209, which allows the change from mark to space to be made as a smooth progression of intermediate frequencies directly related to the selected keying rate. This reduces side band energy normally produced by the nearly instantaneous change from mark to space associated with the more commonly used FSK technique.

FREDERICK ELECTRONICS

The location of the used cards are depicted in Figure 1-1. The keypad and plasma display are located on the front panel.

NOTE

When the unit is configured as a dual demodulator, only one of the demodulators will operate at 1200 baud. The second demodulator is limited to 600 baud operation.

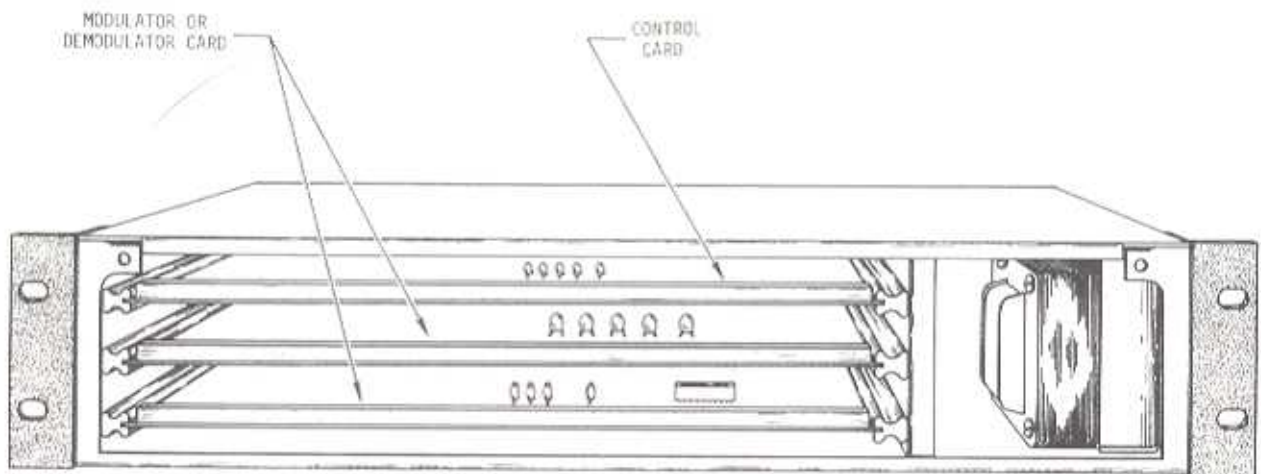

Figure 1-1. Unit With Front Panel Removed

The parameters selectable by the front panel keypad (or remote terminal) are as follows:

- a. Channel (one or two)
- b. Keying Type (FSK, Mark Only, Space Only, FEK)
- c. Diversity
- d. Mark Frequency
- e. Space Frequency
- f. Synchronous/Asynchronous mode
- g. Mute
- h. Baud Rate
- i. Output Polarity (normal or reverse)
- j. Auto Mark Hold/Hold (Standby)

FREDERICK ELECTRONICS

A detailed functional analysis of each board is provided in Section IV, Theory of Operation.

Specifications are listed in Table 1-1.

Table 1-1. Modem Specifications

ITEM	SPECIFICATION
<u>MODULATOR</u>	
Output Impedance	600 ohms \pm 10% (balanced and isolated).
Output Level	Adjustable internally from -20 dBm to +6 dBm into 600 ohms.
Output Frequency Range	300-6000 Hz 300-3000 Hz (special order)
Shift	60-200 Hz (FSK) 60-2700 Hz (FEK) (special order) 60-3000 Hz (FEK)
Transmit Clock*	EIA-RS-232
Mark and Space Tones	Selectable in 0.5 Hz increments.
Mute (low level only)	Automatic (strap selectable), 0-2.25 seconds transition time (switch selectable). Manual (keypad selectable)
Input Data	EIA-RS-232C, MIL-STD-188C, or optional High Level Loop
Sense	Selectable
Waveform Quality	Level of any harmonic will be less than -40 dB referenced to 0 dBm tone output. Maximum level of spurious output -60 dBm tone into 600 ohms.
■ Keyline Control*	Keyline disabled if no transitions are detected within preset time (0-2.25 seconds). (Standard)

*Added Feature

Table 1-1. Modem Specifications (cont.)

ITEM	SPECIFICATION
<u>DEMULATOR</u>	
Input Impedance	600 or 10K ohms (balanced and isolated, strap selectable.)
Input Level	+6 to -45 dBm into 600 ohms
Input Frequency Range	300-6000 Hz 300-3000 Hz (special order)
Mark and Space Frequency	Selectable in 0.5 Hz steps.
Shift Standard Configuration	60 to 3000 Hz up to 600 baud 850 to 1200 Hz from 601 to 1200 baud. 60 to 2700 Hz (special order)
Baud Rate	Selectable 30 to 1200.
Diversity	Selectable in two-channel DEMOD configuration only. (Up to 600 baud only with the standard configuration).
Data Output	Selectable (keypad or remote).
Synchronous Mode Asynchronous Mode	Regenerated EIA-RS-232 and MIL-STD-188C. Programmable 5, 6, 7, or 8-level, EIA-RS-232 and MIL-STD-188C.
Mid-Bit Clock	EIA-RS-232
Auto Mark Hold/ Carrier Detect	Switch selectable 0 to -42 dBm in 6 dB increments, 1 to 5 second delay (switch selectable) after signal drops below threshold. Carrier detect sense is strap selectable.*
Sense	Selectable (keypad or remote).
Indicators	Plasma display of energy in filter (bar graphs), frequency of mark/space tones, and baud rate.

*Added Feature

Table 1-1. Modem Specifications (cont.)

ITEM	SPECIFICATION
<u>REMOTE CONTROL</u>	
Device Number	Switch selectable 01 thru 08.
Data In/Out	EIA-RS-232C Asynchronous (1 start bit, 8 data bits, 2 stop bits).
Status	Received data only.
Data Rate	Strap Selectable for 300, 600, 1200, 2400, 4800, 9600, or 19,200 baud.
<u>GENERAL</u>	
Dimensions	19 in (48.26 cm) W x 3.5 in (8.89 cm) H x 14 in (35.56 cm) D. With High Level or DC Power Supply Options, 18 in (45.72 cm) D; with High Level and DC Power Supply Options, 22 in (55.88 cm) D; with MS Connector Panel 16.69 in (42.4 cm) D; and with MS Connector Bulkhead 22.1 in (56.13 cm) D.
Weight	Approximately 12 lbs. (5.44 Kg).
Voltage	115/230 Vac \pm 15%, 47 to 440 Hz (switch card selectable).
Optional Voltage #1	10 to 16 Vdc, 6A maximum at 10V.
Optional Voltage #2	19 to 31 Vdc, 2.5A maximum at 19V.

Table 1-1. Modem Specifications (cont.)

ITEM	SPECIFICATION
<u>ENVIRONMENTAL</u>	
Operating Range	
Temperature	0° to 50°C (32° to 122°F)
Humidity	To 95% non-condensing.
Altitude	MSL to 10,000 feet.
Non-Operating Range	
Temperature	-40° to +80°C
Humidity	To 95% non-condensing.
Altitude	MSL to 50,000 feet.
<u>OPTIONAL HIGH LEVEL</u>	
Loop Power Supply	+ 65 Vdc at 80 mA max. (non-regulated)
Keyer	Polar/neutral contacts isolated 80 mA max.

1.3 LIST OF ITEMS SUPPLIED

Items supplied with the Model 1280A are listed in Table 1-2.

Table 1-2. List of Items Supplied

ITEM	QUANTITY	PART NUMBER
Model 1280A FSK Modem NOTE: May be configured as a modem or as a two-channel demodulator or a two-channel modulator as selected (refer to paragraph 1.5).	1 ea	M1280A
Technical Manual	1 ea	TMC21201
AK 1280A (Accessory Kit)		
Line Cord	1 ea	366020
Connector Plug	1 ea	241192
Contact, Male, Crimp	9 ea	744810
Placard	1 ea	085700

1.4 CONFIGURATION IDENTIFICATION

Configuration of the Model 1280A, as shipped from the factory, can be identified by the Part Number on the rear I.D. Plate. The physical configuration of the Model 1280A is defined by the model number: M1280A-ABCDE, where:

- A = Mod/Demod Combination
- 1 = 1 Demod
 - 2 = 2 Demods
 - 3 = 1 Mod (D9096)
 - 4 = 2 Mods (D9096)
 - 5 = 1 Mod (D9096) and 1 Demod
 - 6 = 1 Mod (D9676) and 1 Demod
(Radio Keyline controlled by RTS/CTS)
- B = Rear Panel
- 0 = Standard (Barrier Strip)
 - 1 = D9124 MS Connector (A must be 5)
 - 2 = D9284 MS Connectors

FREDERICK ELECTRONICS

- C = Interface
 - 0 = Standard Low Level
 - 1 = High Level (Cannot be used when B = 1)

- D = Power
 - 0 = AC
 - 1 = 12V DC (Cannot be used when B = 1)
 - 2 = 24V DC (Cannot be used when B = 1)

- E = Firmware
 - 0 = Bundespost
 - 1 = Extended Frequencies (6 KHz)

FREDERICK ELECTRONICS

SECTION II

INSTALLATION

2.1 GENERAL

This section contains instructions for unpacking, mounting, and connecting the 1280A and its optional equipment.

2.2 UNPACKING AND INSPECTION

Open the shipping container. Do not use sharp metallic objects that might damage the contents. Remove the packing and the unit from the container and inspect for damage. If any damage is observed, file a written claim with the shipping agency and forward a copy of the claim to:

SFA DataComm, Inc./Frederick Electronics
7450 New Technology Way
Frederick, Maryland 21701
Attn: Customer Service

Phone: (301) 662-5901
Fax: (301) 662-1996

If packing for storage or reshipment is anticipated, replace the packing material in the shipping container and store for future use.

2.3 POWER REQUIREMENTS

The Modem operates on either 115 or 230 Vac, +15 percent, 47 to 440 Hz or with optional Direct Current (dc) supplies, 10 to 16 Vdc (6 Amps. maximum at 10V) or 19 to 31 Vdc (2.5 Amps. maximum at 19V). The unit can be set to operate on 115 volts or 230 volts by the position of the printed circuit (switch) board, located behind the fuse (F1) on the lower right-hand side of the unit. (Refer to Figure 2-1.) Power switch (S1) is located on the front panel. Turn the switch to the ON position to apply power.

* W A R N I N G *

The AC input circuit of this unit contains voltages which may be hazardous to life. Exercise caution while working in the unit when protective cover is removed.

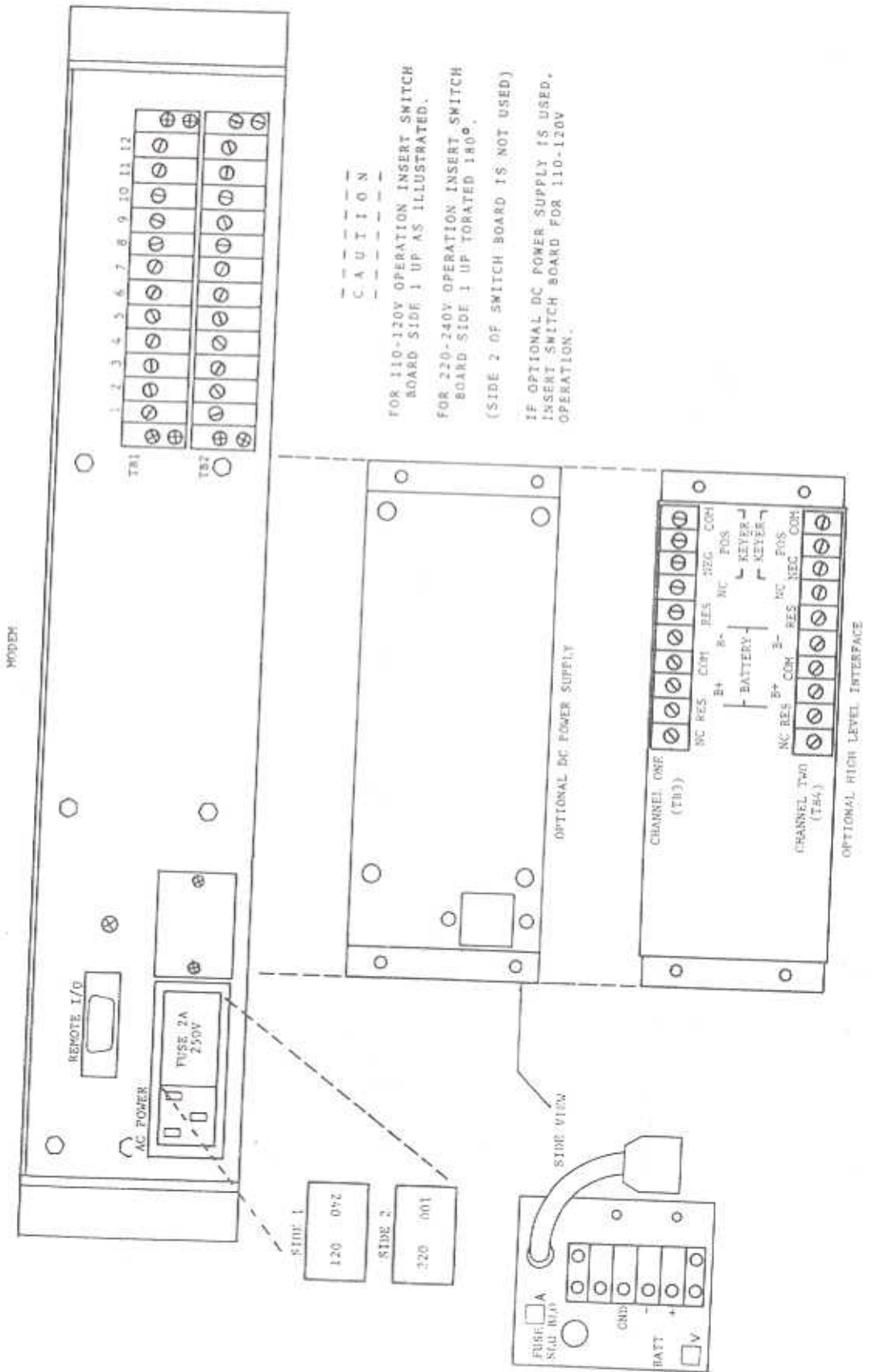

CAUTION

FOR 110-120V OPERATION INSERT SWITCH BOARD SIDE 1 UP AS ILLUSTRATED.

FOR 220-240V OPERATION INSERT SWITCH BOARD SIDE 1 UP TORATED 180°.

(SIDE 2 OF SWITCH BOARD IS NOT USED)

IF OPTIONAL DC POWER SUPPLY IS USED, INSERT SWITCH BOARD FOR 110-120V OPERATION.

Figure 2-1. Rear Panel

- - - - -
C A U T I O N
- - - - -

Ensure the switchboard is inserted correctly for the input voltage being used. Refer to Figure 2-1.

2.4 MOUNTING

The Model 1280A is designed to mount in a standard 19 inch (48.3 cm) rack. A vertical rack space of 3.5 inches (8.9 cm) is required. Refer to Figure 2-2 for an installation drawing that provides unit dimensions.

2.5 OPTIONS

The M1280A can be configured with several different rear panel mounted options.

2.5.1 DC Power Supply

The DC power supply is available with voltages of 10-16 Vdc (12 Vdc nominal) or 19 to 31 Vdc (24 Vdc nominal) and mounts directly to the rear of the Model 1280A (refer to Figure 2-1). If this unit is used, the AC line cord is removed and the DC supply is connected to the M1280A AC power connector. The unit contains a DC fuse (5A SLO-BLO for 19 to 31 Vdc operation or 7A SLO-BLO for 10 to 16 Vdc operation).

- - - - -
C A U T I O N
- - - - -

The fused switchboard must be inserted for 110-120V operation. (Refer to Figure 2-1.)

2.5.2 High Level Interface

The High Level (HL) Interface unit consists of a loop power supply and quad high level keyer that allows high level (20/60 mA) polar/neutral operation. The HL Interface unit mounts directly on the rear of the M1280A or, if used with the DC power supply, mounts on the rear of the DC supply (refer to Figure 2-1).

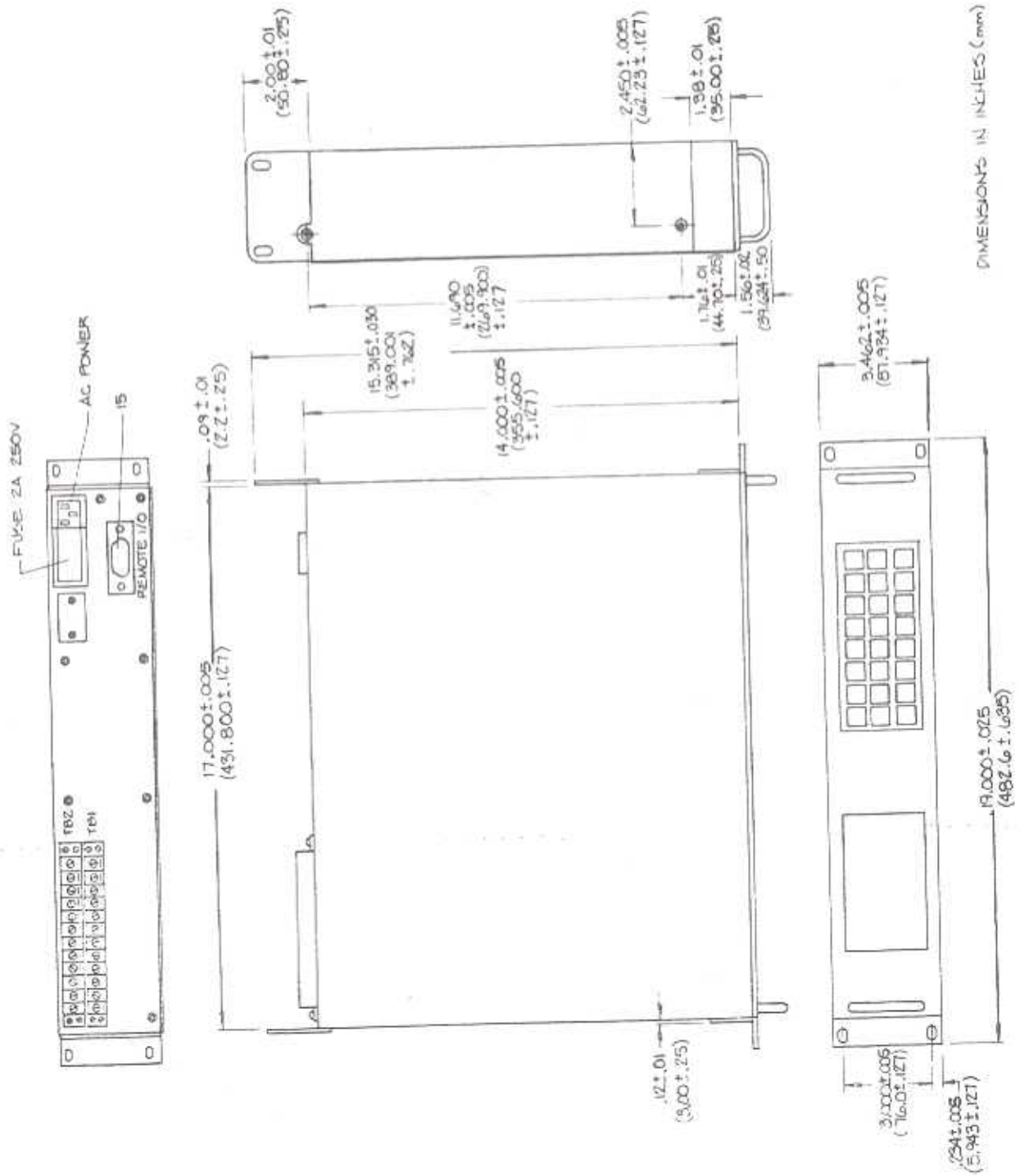

Figure 2-2. Installation Drawing

2.5.3 MS Connector Panel (D9124)

The MS connector panel (see Figure 2-3) provides signal connections via military style connectors. With this option, the M1280A can be configured as a modem only. The demodulator board must be inserted in Channel 1 position (backplane connector J3) and the modulator in Channel 2 position (backplane connector J4). Refer to Figure 6-40 and 6-41 for mating connector kits.

N O T E

If this connector panel is selected, access to the fused switchboard is through the fuse plate.

If this option is selected the HL Interface and DC power supply cannot be used.

2.5.4 MS Connector Bulkhead (D9284)

The MS Connector Bulkhead (see Figure 2-4) mounts on the rear of the Model 1280A. It provides military style connections for both signal and power. This unit can operate on 115/230 Vac, with optional and selectable 10-16 Vdc or 19-31 Vdc power supplies, and with an optional high level interface assembly. It contains an identification plate allowing the user to identify the configuration of the unit. (Refer to Figure 6-43 for mating connector kit.)

The unit contains an AC fuse (2A, 250V for 115 Vac and DC operation or 1A, 250V for 230 Vac operation) and a DC fuse (5A SLO-BLO for 19 to 31 Vdc operation or 7A SLO-BLO for 10 to 16 Vdc operation).

* * * * *
* W A R N I N G *
* * * * *

The AC input circuit and power supply circuits of this unit contain voltages which may be hazardous to life. Exercise caution while working in the unit when protective covers are removed.

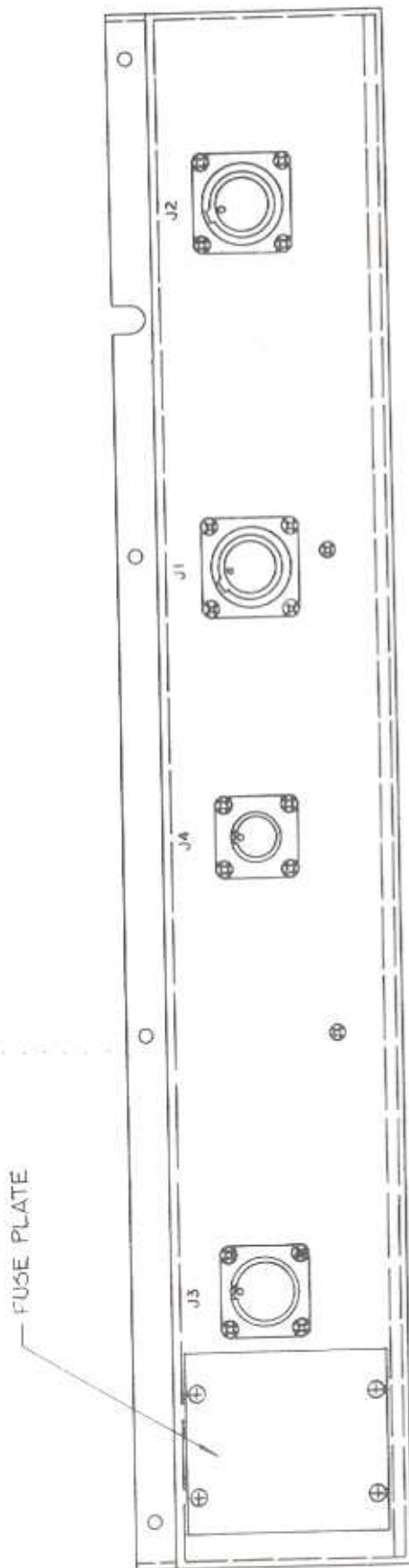

Figure 2-3. Optional Rear Panel (D9124) with MS Connectors

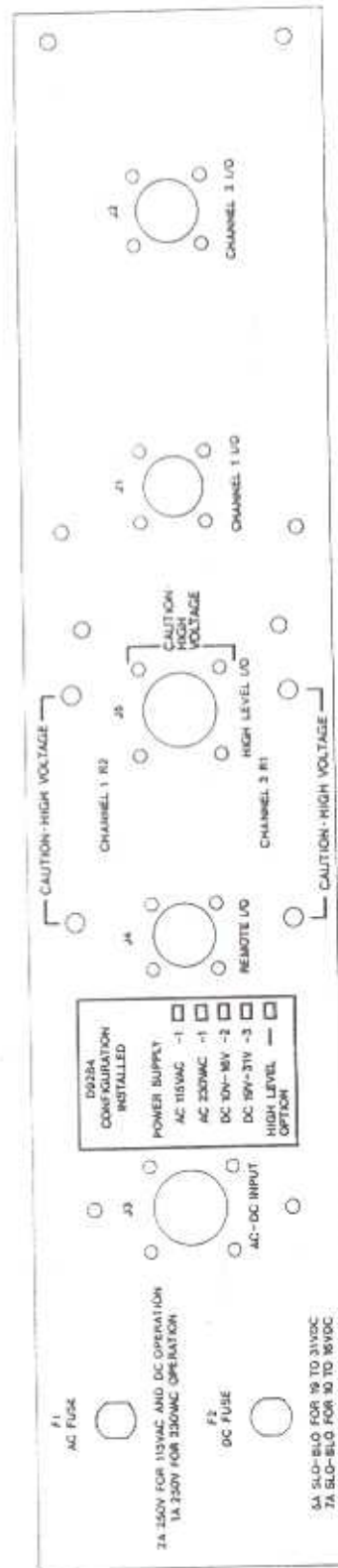

Figure 2-4. Optional MS Connector Bulkhead (D9284)

When the high level option is used, loop current must be externally limited to 80 mA maximum (60 mA typical) from each leg of the battery and arc suppression to less than 300 volts. Connections are provided on the rear of the unit to install current limiting resistors. Recommended limiting resistor for 20 mA neutral operation is 6500 ohms, 10 watts, and for 60 mA neutral, operation is 2200 ohms, 10 watts.

* * * * *
* W A R N I N G *
* * * * *

The current limiting resistors contain high voltage. Exercise extreme care while working with the unit. (Refer to Figure 6-40 for the location of the receive loop current limiting resistors.)

N O T E

The unit will not operate without current-limiting resistors.

2.6 SIGNAL CONNECTIONS

All signal connections to the modem are made on the rear panel and on the optional High Level Keyer Supply. An optional rear panel is available with MS connectors. (The High Level and DC options are not available with the optional rear panel.) Connections for the standard rear panel and High Level option are illustrated in Figure 2-1 and listed in Tables 2-1 and 2-2. The optional MS connector rear panel is illustrated in Figure 2-3 with connections listed in Table 2-3. The MS Connector Bulkhead is illustrated in Figure 2-4 with connections listed in Table 2-4.

- - - - -
C A U T I O N
- - - - -

High level loop current must be externally limited to 80 mA maximum (60 mA typical) and arc suppression to less than 300 volts.

N O T E

WITH THE STANDARD CONFIGURATION INSTALLED and the unit operated as a modem, the demodulator must be installed in backplane connector J3 for baud rates above 600. If operated as a dual demodulator only, the demodulator in backplane connector J3 will operate at 1200 baud. The demodulator in backplane connector J4 is limited to 600 baud operation and, if programmed for speeds greater than 600, Channel 2 will cease to output data.

2.6.1 Analog Cable (C5569)

The analog cable interface allows the Model 1280A to connect directly into a Transworld TW100F transceiver. The cable connects to J2 of the optional MS connector panel (D9124). Refer to Table 2-3 for pin configuration.

2.6.2 Digital Cable (C5568)

The digital cable interface allows the Model 1280A to connect directly into a KG84A encryption device. The cable connects to J1 of the optional MS connector panel (D9124). Refer to Table 2-3 for panel pin configuration.

Table 2-1. Modem Signal Connections

PIN NUMBER TB1/TB2	EXPLANATION
Signal connections to TB1/TB2 are determined by the board type (modulator or demodulator) that is installed in each location. TB1 corresponds to channel 1 position (backplane connector J3) and TB2 corresponds to channel 2 position (backplane connector J4).	
Modulator	Input/Output Signals
1	- High Level Input
2	+ High Level Input
3	Transmit Clock Output
4	Keyline
5	MARK Frequency Output
6	SPACE Frequency Output
7	Low Level Input - RS232 + FSK TO RIG.
8	Keyline
9	Balanced Output - AFSK
10	Balanced Output - AFSK
11	Analog Ground
12	Analog Ground
Demodulator	Input/Output Signals
1	NC
2	NC
3	Data Mid-Bit Sample
4	Carrier Detect
5	Undetected MARK - SCOPE TUNING
6	Undetected SPACE - SCOPE TUNING
7	Data Output RS-232-C
8	Data Output MIL-188-C
9	Balanced Audio Input
10	Balanced Audio Input
11	Ground
12	Ground

Table 2-1. Modem Signal Connections (cont.)

PIN NUMBER J5	EXPLANATION
Remote I/O	Remote Terminal Input/Output Connections
1	Data Input
2	Data Output
3	Busy In (DTR)
4	Busy Out (CTS)
5	+12V Static
6	N.C.
7	Ground
8	N.C.
9	N.C.
AC POWER	115 Vac/230 Vac/dc Power Connector

Table 2-2. Optional High Level Keyer/Loop Supply Signal Connections

PIN CONNECTION	EXPLANATION
Signal connections to TB3/TB4 are identical and provide high level output(s) for corresponding demodulator(s).	
NC	NC Connection
RES	External Current Limiting Resistor
B+ >	Internal Loop Positive (+) Battery (B+)
COM > BATTERY	Internal Loop Common (BCOMM)
B- >	Internal Loop Negative (-) Battery (B-)
RES	External Current Limiting Resistor
NC	NC
NEG >	MARK Keyer Output (MK)
POS > KEYER	SPACE Keyer Output (SP)
COM >	Keyer Loop Common (LP COMM)

Table 2-3. Optional MS Connector (D9124) Rear Panel Connections

CONNECTOR/PIN	SIGNAL	CHASSIS CONNECTING TERMINAL
NOTE		
With this option, the demodulator board must be inserted in Channel 1 position (backplane connector J3) and the modulator in Channel 2 position (backplane connector J4).		
J1-1 THRU 6	No Connection (NC)	
7	Demod Undetected Mark Output	TB1-5
8	Jumper	J2-8
9	Demod Undetected Space Output	TB1-6
10	Carrier Detect Output	TB1-4
11	NC	
12	Demod Analog Ground	TB1-11
13	Ground	TB1-12
14	Ground	TB1-11
15	Keyline	TB2-4
16	Keyline	TB2-8
17 AND 18	NC	
19	Transmit Clock Output	TB2-3
20	Mod Digital Data Input	TB2-7
21	Demod Mid-Bit Clock	TB1-3
22	Demod Digital Data Output (RS-232-C)	TB1-7
23	Demod Digital Data Output (MIL-188-C)	TB1-8
24	Mod Analog Ground	TB2-11
25	Ground	TB2-11
26	Ground	TB2-12
27 THRU 35	NC	
36	Mod Analog Ground	TB2-12
37	Shield	
J2-1	Mod FSK Output	TB2-9
2	NC	
3	Mod FSK Output	TB2-10
4	NC	
5	Keyline	TB2-4
6	Keyline	TB2-8
7	NC	
8	Jumper	J1-8
9	NC	
10	Demod FSK Input	TB1-9
11	NC	
12	Demod FSK Input	TB1-10
13 THRU 36	NC	
37	Shield	Chassis

Table 2-3. Optional MS Connector (D9124) Rear Panel Connections (cont.)

CONNECTOR/PIN	SIGNAL	CHASSIS CONNECTING TERMINAL
J3-A B THRU C D E THRU J K	Ground NC Neutral NC Hot	AC Power Connector
J4-1 2 3 4 5 6 7 THRU 13	Data Input Busy In (DTR) Data Output +12V Static Busy Out (CTS) Ground NC	J5-1 J5-3 J5-2 J5-5 J5-4 J5-7

Table 2-4. Optional MS Connector Bulkhead (D9284) Connections

CONNECTOR/PIN	SIGNAL	CONNECTING TERMINAL
<p>CHANNEL 1 I/O (J1) AND CHANNEL 2 I/O (J2)</p>	<p>N O T E</p> <p>Signal connections to J1/J2 are determined by the board type (modulator or demodulator) installed in chassis backplane connectors J3 (Channel-1, Connector J1) and J4 (Channel-2, Connector J2).</p>	<p>(CHASSIS)</p>
<p>(MODULATOR) J1/J2-1 and 2</p> <p>3</p> <p>4</p> <p>5</p> <p>6</p> <p>7</p> <p>8</p> <p>9</p> <p>10</p> <p>11</p> <p>12</p> <p>13</p>	<p>NC</p> <p>Transmit Clock Output</p> <p>Keyline</p> <p>Mark Frequency Output</p> <p>Space Frequency Output</p> <p>Low Level Input</p> <p>Keyline</p> <p>Balanced Audio Output</p> <p>Balanced Audio Output</p> <p>Analog Ground</p> <p>Analog Ground</p> <p>Ground</p>	<p>TB1-3</p> <p>TB1-4</p> <p>TB1-5</p> <p>TB1-6</p> <p>TB1-7</p> <p>TB1-8</p> <p>TB1-9</p> <p>TB1-10</p> <p>TB1-11</p> <p>TB1-12</p>
<p>(DEMODULATOR) J1/J2-1 and 2</p> <p>3</p> <p>4</p> <p>5</p> <p>6</p> <p>7</p> <p>8</p> <p>9</p> <p>10</p> <p>11</p> <p>12</p> <p>13</p>	<p>NC</p> <p>Data Mid-Bit Sample</p> <p>Carrier Detect</p> <p>Undetected Mark</p> <p>Undetected Space</p> <p>Data Output RS-232 C</p> <p>Data Output MIL-188-C</p> <p>Balanced Audio Input</p> <p>Balanced Audio Input</p> <p>Ground</p> <p>Ground</p> <p>NC</p>	<p>TB2-3</p> <p>TB2-4</p> <p>TB2-5</p> <p>TB2-6</p> <p>TB2-7</p> <p>TB2-8</p> <p>TB2-9</p> <p>TB2-10</p> <p>TB2-11</p> <p>TB2-12</p>

Table 2-4. Optional MS Connector Bulkhead (D9284) Connections
(cont.)

CONNECTOR/PIN	SIGNAL	CONNECTING TERMINAL
AC-DC INPUT		
J3-A	AC Chassis Ground*	**P6-2
B and C	NC	
D	AC NEUTRAL	P6-3
E	DC CHASSIS GROUND*	***P1-2
F	DC (+) Positive Battery Input	DC P1-4
G AND H	NC	
J	DC (-) Negative Battery Input	DC P1-6
K	AC Hot	P6-1
<p>*These are not common connections and must be wired separately as required. **P6 is the DC/AC INTERCONNECT CABLE (C4166). ***P1 is the Rear Power Connector Assembly (C4165).</p>		
REMOTE I/O		(CHASSIS)
J4-1	Data Input	J5-1
2	Busy In (DTR)	J5-3
3	Data Output	J5-2
4	+12V Static	J5-5
5	Busy Out (CTS)	J5-4
6	Ground	J5-7
7 thru 13	NC	
HIGH LEVEL I/O	High Level	(HL ASSY C5851)
J5-1	Demod 1 Negative Keyer	TB3-8
2	Demod 1 Keyer Common	TB3-10
3	Demod 1 Positive Keyer	TB3-9
4	Demod 1 B+	TB3-3
5	Demod 1 B Common	TB3-4
6	Demod 1 B-	TB3-5
7 and 8	NC	
9	Demod 2 B-	TB4-5
10	Demod 2 B Common	TB4-4
11	Demod 2 B+	TB4-3
12	Demod 2 Positive Keyer	TB4-9
13	Demod 2 Keyer Common	TB4-10
14	Demod 2 Negative Keyer	TB4-8
15	Mod 2 Negative HL Input	TB2-1 (Chassis)
16	Mod 2 Positive HL Input	TB2-2 (Chassis)
17 thru 19	NC	
20	Mod 1 Positive HL Input	TB1-2 (Chassis)
21	Mod 1 Negative HL Input	TB1-1 (Chassis)
22	NC	

Table 2-4. Optional MS Connector Bulkhead (D9284) Connections (cont.)

CONNECTOR/PIN	SIGNAL	CONNECTING TERMINAL
CHANNEL 1 R2		(HL ASSY C5851)
E1	HL Current Limiting	TB3-2
E2	HL Current Limiting	TB3-6
CHANNEL 2 R1		
E3	HL Current Limiting	TB4-2
E4	HL Current Limiting	TB4-6

2.6.3 Remote Control I/O Connections

Remote control I/O connections for the Model 1280A are shown in Figure 2-5.

The use of handshake lines (Busy In and Busy Out) is not mandatory when connecting the unit to an external ASCII device. Figure 2-6 shows typical interface connections for the 1280A with and without the use of handshaking.

	STANDARD REAR PANEL 9 Pin 'D' Connector	OPTIONAL D9124 or D9284 REAR PANELS 13 Pin 'MS' Connector
DATA IN	J5-1	J4-1
DATA OUT	J5-2	J4-3
BUSY IN	J5-3	J4-2
BUSY OUT	J5-4	J4-5
+12 V	J5-5	J4-4
GROUND	J5-7	J4-6

Figure 2-5. Remote Control I/O Connections

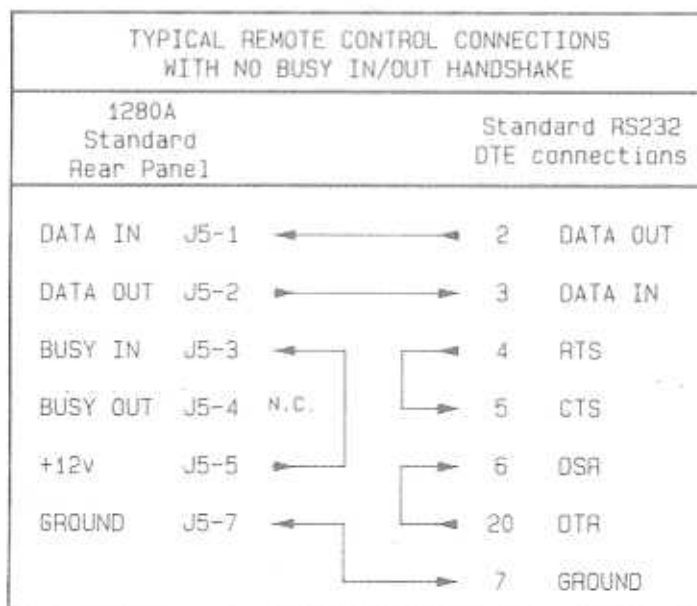
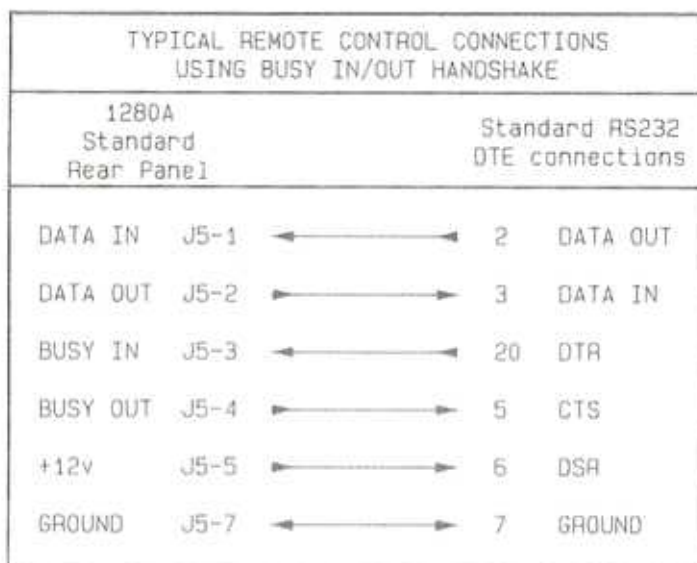

Figure 2-6. Typical Interface Connections

2.7 STRAPPING AND SWITCH CONFIGURATIONS

Several switches and jumpers allow the Model 1280A to be modified by the user to suit different applications and should be set before power is applied. These are identified by PWB.

2.7.1 Control Board

2.7.1.1 REMOTE I/O BAUD RATE SELECTION. The baud rate selection for the remote control device is accomplished by installing a jumper in the header U8 as shown in Figures 2-7 and 2-8. Labels adjacent to U8 indicate the baud rate achieved by each jumper.

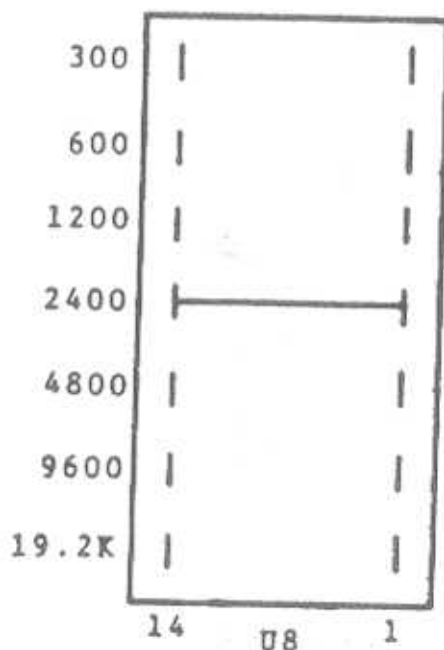

Figure 2-7. Remote I/O Baud Rate Selection

2.7.1.2 REMOTE I/O DEVICE ADDRESS SELECTION. The remote control device address is selectable by switch S1 as shown in Figure 2-7. The address selected by each switch is labeled adjacent to the switch from 01 through 08.

Switch S1 selects the identification number of the unit when more than one unit is being controlled by the same remote device.

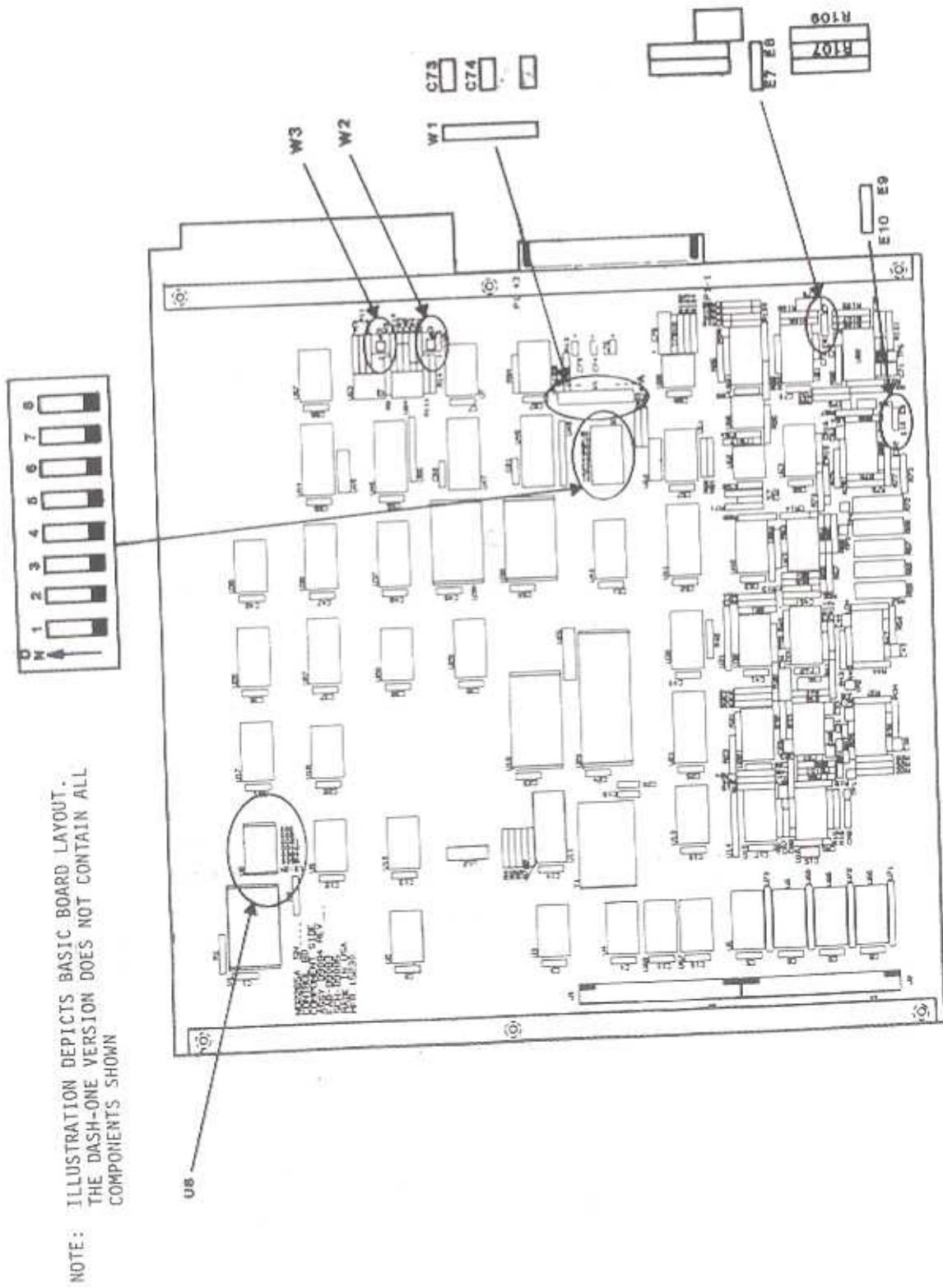

Figure 2-8. Expanded View of Control Board Showing Jumper and Switch Locations

FREDERICK ELECTRONICS

2.7.1.3 REMOTE CONTROL I/O SPECIFICATIONS. The remote control I/O specifications are as follows:

DATA FORMAT: EIA-RS-232 Serial ASCII characters.

1 Start bit, 7⁸ Data bits, 1 Parity bit,
and 2 Stop bits.

Upper and Lower Case characters are accepted.

Parity is ignored on incoming characters.

Parity is disabled on STATUS and ERROR response output characters (Bit 8 = 0).

When ECHO is enabled, the character is sent to the remote control output line exactly as it was received from the input line.

DATA RATE: 300, 600, 1200, 2400, 4800, 9600 or 19200 Baud.

Determined by selection of jumper wire on U8 on the Control Board.

2.7.1.4 REMOTE CONTROL I/O DESCRIPTION

Remote Control Input - This line is used to input remote control commands to the unit.

Remote Control Output - This line is used to output status and error responses from the unit. It will also output any characters received from the remote control input line if ECHO is enabled. This output has tri-state capability and will remain in a high-impedance state when not transmitting data.

2.7.1.5 HANDSHAKING

Unit Busy Input - This line is used to indicate to the unit that the remote controller device is busy and is unable to accept data from the Remote Control Output line. When this line is held in a negative state (-4V to -12V) the remote control output line is disabled. When it is held in a positive state (+4V to +12V), the remote control output line is enabled. A current limited, positive voltage source has been provided to connect to this input when it is not used elsewhere.

N O T E

This line should not be held negative for an extended period. If the unit attempts to output data on the remote output line, it will cease further processing until the line is returned positive. The modulator and demodulator boards will continue to function normally but the unit will not accept remote commands and the keypad will be disabled.

Unit Busy Output - This line is used to indicate to the remote control device that the unit is busy and is unable to accept data from the remote control input line. This line will go negative upon detection of a carriage return character (HEX 0D) on the remote control input and will return to positive when command processing is complete. The length of time required to process the remote commands will determine the length of time that the unit will be busy. Normal command lines, with no errors or requests for status, typically require 15 to 20 ms for processing. This time is independent of the data rate. Commands that result in status or error responses require an increased amount of time which is based upon the length of the output response message and the selected data rate. There is typically a 150 ms delay between detection of the carriage return character and any status or error responses and between successive error responses resulting from the same command line. If the unit-busy-output line is not used, it is recommended that the remote control device monitor the remote control output line. If no characters have been detected within 150 ms from the end of the carriage return in the command line, then the unit may be assumed to be available for further remote commands. If a character is detected, the remote controller should accept the data and restart the 150 ms timer.

2.7.1.6 PWB JUMPERS. The following jumpers, illustrated in Figure 2-8, are provided for operations as follows.

JUMPER	POSITION	DESCRIPTION
W1	IN	Test probe ground "always installed."
W2	1-2	Remote output terminated.
W3	1-2	Busy out terminated.
W2	2-3	Remote output not terminated.
W3	2-3	Busy out not terminated.

NOTE: Single unit operation - install both W2 and W3 in 1-2 position. For multi-unit operation, install W2 and W3 in 1-2 position in one unit. Install W2 and W3 in 2-3 position in remaining units.

JUMPER	POSITION	DESCRIPTION
E7-8	Always Open	
E9-10	Always Open	

2.7.2 Demodulator Board

2.7.2.1 AUTO MARK HOLD (AMH) THRESHOLD SWITCH. The AMH threshold level is selected by switch S7 (refer to Figure 2-9) for low speed operation and for high speed operation.

The threshold value is selectable between 0 dBm and -42 dBm in eight 3 dB steps (0 dBm and -42 dBm in eight 6 dB steps for low speed and -2 dBm and -21 dBm in four variable dB steps for high speed) as specified below.

<u>LOW SPEED</u>	<u>HIGH SPEED</u>
Slide 1 = 0 dBm	Slide 1 = -2 <u>+3</u> dBm
Slide 2 = -6 dBm	
Slide 3 = -12 dBm	Slide 3 = -10 <u>+3</u> dBm
Slide 4 = -18 dBm	
Slide 5 = -24 dBm	Slide 5 = -16 <u>+3</u> dBm
Slide 6 = -30 dBm	
Slide 7 = -36 dBm	Slide 7 = -21 <u>+3</u> dBm
Slide 8 = -42 dBm	

2.7.2.2 AMH DELAY SWITCH. The AMH delay switch (S8) allows a delay of one to five seconds after the AMH threshold has been exceeded prior to entering AMH. With all switch slides OFF, a five-second delay is provided. Other selections are identified below. Only one slide position should be selected at a time.

- S8 - Slide 1 ON = 4 seconds delay
- S8 - Slide 2 ON = 3 seconds delay
- S8 - Slide 3 ON = 2 seconds delay
- S8 - Slide 4 ON = 1 second delay

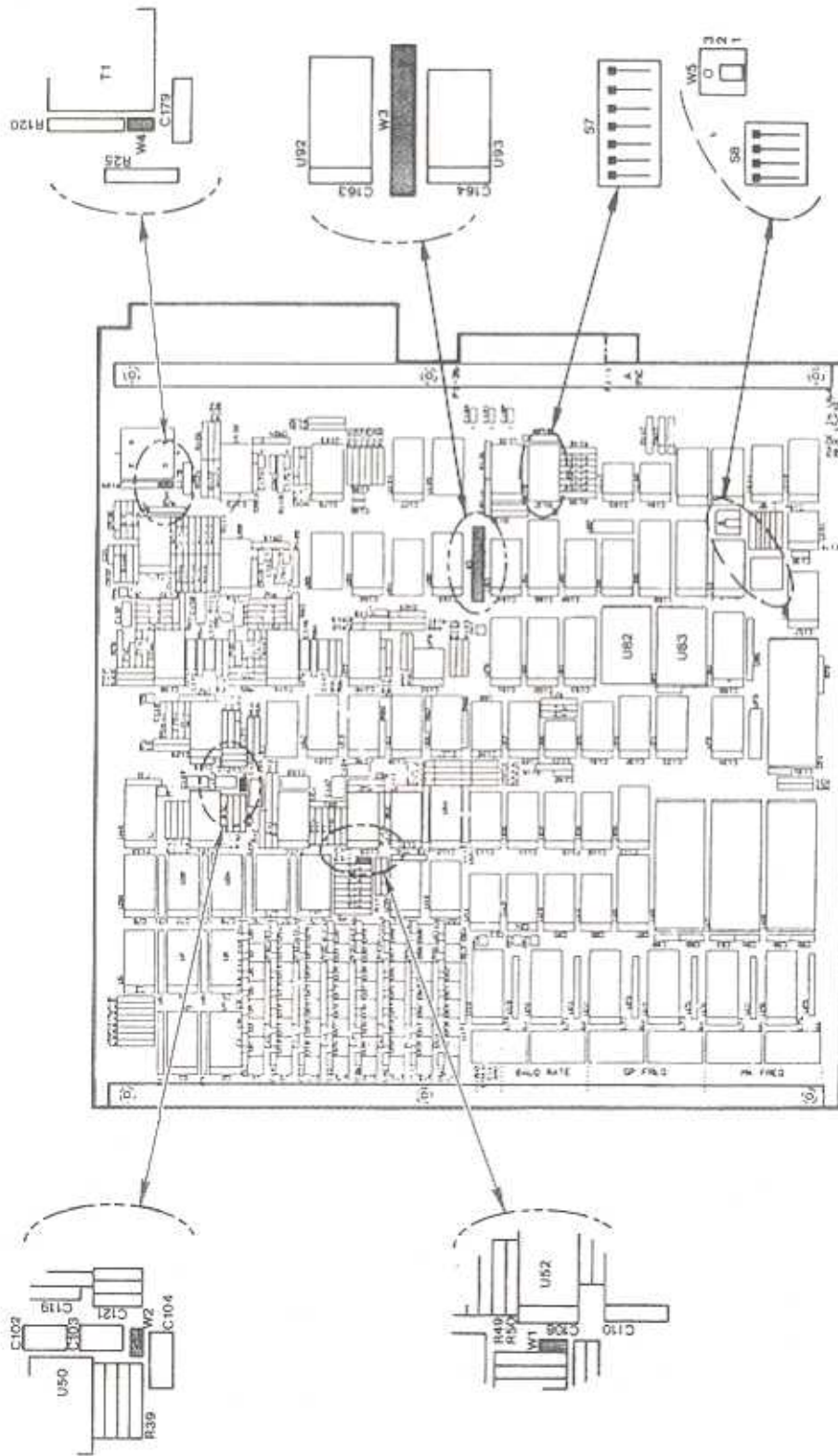

Figure 2-9. Expanded View of Demodulator Board
Showing Locations of Jumpers and Switches

2.7.2.3 PWB JUMPERS AND OPTIONS. The following jumpers and options, shown in Figure 2-8, will yield the indicated results:

JUMPER	IN	OUT	RESULTS
W1	X		Commutating filter feedback, "normally installed." Removed for troubleshooting only.
W2	X		Commutating filter feedback, "normally installed." Removed for troubleshooting only.
W3	X		Test probe ground "always installed."
W4	X		600 ohm input impedance.
W4		X	10K ohm input impedance.
W5	1-2		Detects loss of carrier (positive potential).
W5	2-3		Detects loss of carrier (negative potential).
EPROM SC575 U82/U83	X		Allows operation to 1200 baud (D9087 only).
EPROM SC614 U83	X		Allows operation 30 to 1200 baud (D9087-1 only).

2.7.3 Modulator Board(s)

2.7.3.1 AUTO-MUTE TRANSITION DELAY SWITCH. Switch S7 (Figure 2-10) is a four-position switch that allows an operator to select a specified time delay prior to going into the auto-mute and keyline enable condition after a loss of data transitions. Switch slides 3 and 4 provide control data to the down-counter, and slides 1 and 2 provide a count to the down-counter's C/D input. Either slide 1 or 2 must be selected (to enable auto-mute and keyline output), but both may not be selected at the same time. To select the auto-mute thresholds, set program switch S7 as indicated below. Thresholds are specified in seconds.

FREDERICK ELECTRONICS

<u>SWITCH SLIDE (S7)</u>	<u>SWITCH POSITIONS SELECTED</u>								
1	ON	ON	ON	ON	OFF	OFF	OFF	OFF	OFF
2	OFF	OFF	OFF	OFF	ON	ON	ON	ON	ON
3	ON	OFF	ON	OFF	ON	OFF	ON	OFF	OFF
4	ON	ON	OFF	OFF	ON	ON	OFF	OFF	OFF
THRESHOLDS	0	.0625	0.5	0.5625	0	0.250	2.0	2.25	

2.7.3.2 PWB JUMPERS. The following jumpers, shown in Figure 2-10, will yield the indicated results:

<u>JUMPER</u>	<u>POSITION</u>	<u>RESULTS</u>
W1	IN	Test Probe Ground "always installed."
W2	IN	Half-Duplex Operation
W2	OUT	Full-Duplex Operation
W3	OUT	RS-232-C Input
W3	IN	MIL-188-C Input
W4	IN	Auto Mute Enabled
W4	OUT	Auto Mute Disabled
W5	IN	Not used, "always installed."
W6	IN	Not used, "always installed."
W7	IN	20 mA input current.
W8	IN	60 mA input current.
W9	IN	Test probe ground, "always installed."

2.8 INSTALLATION

Signal Connections for typical operating conditions are illustrated in Figures 2-11 through 2-14. For options not illustrated refer to Tables 2-3 and 2-4.

2.9 INITIAL CHECKOUT PROCEDURE

The initial checkout procedures verify operation of the Model 1280A. They should be performed prior to connecting external signal cables. Should a fault occur during these procedures, refer to Section V for troubleshooting procedures.

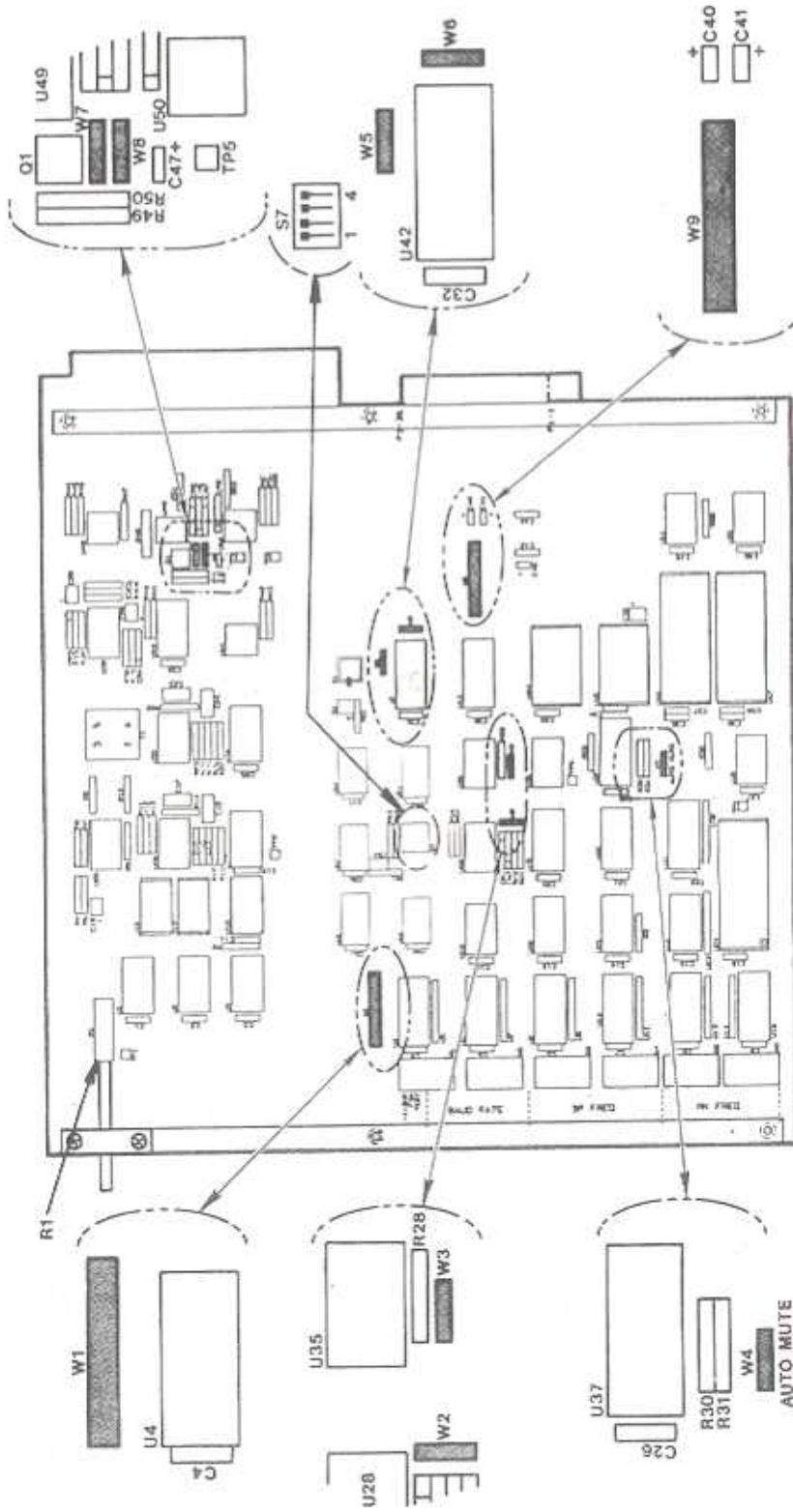

Figure 2-10. Expanded View of Modulator Board Showing Locations of Jumpers and Switches

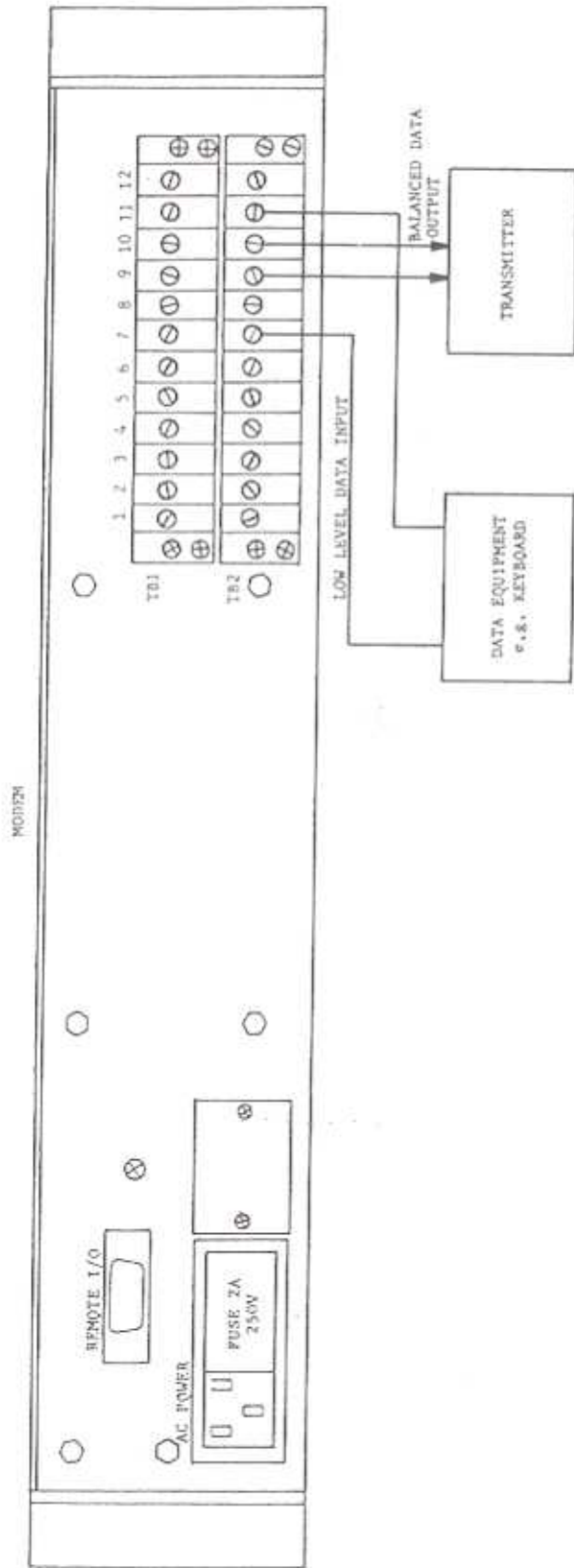
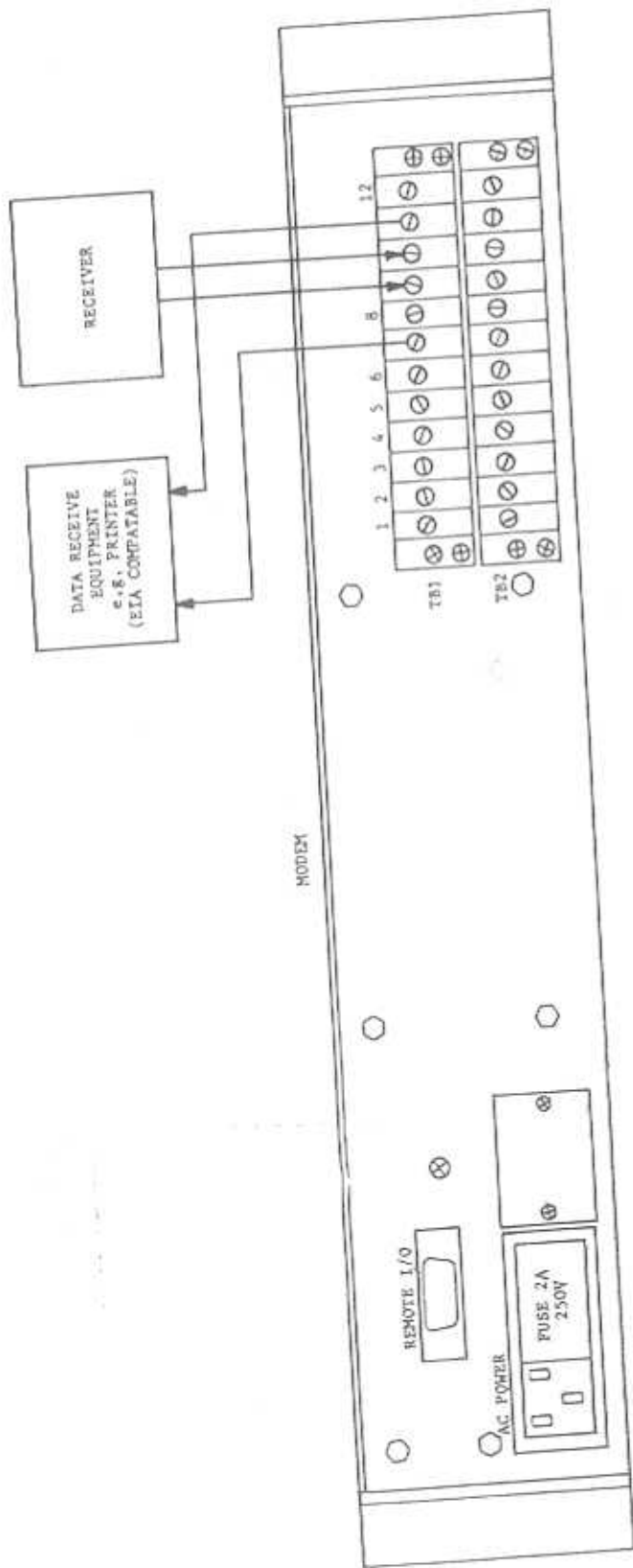

Figure 2-11. Typical Modulator Application



NOTE: When operating in diversity, the enhanced data output is available on both Channel 1 and Channel 2 data terminals.

Figure 2-12. Typical Demodulator Application

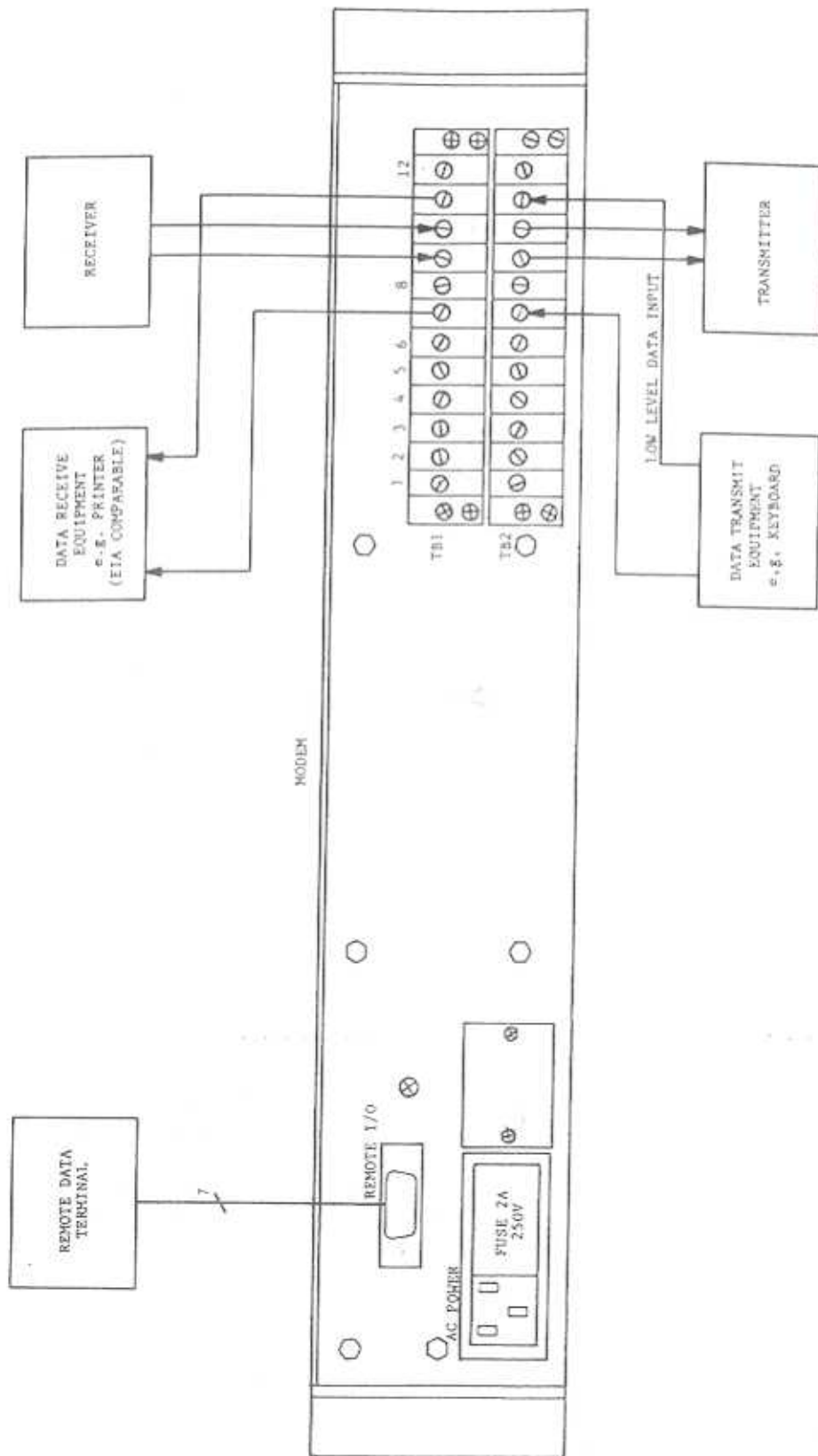
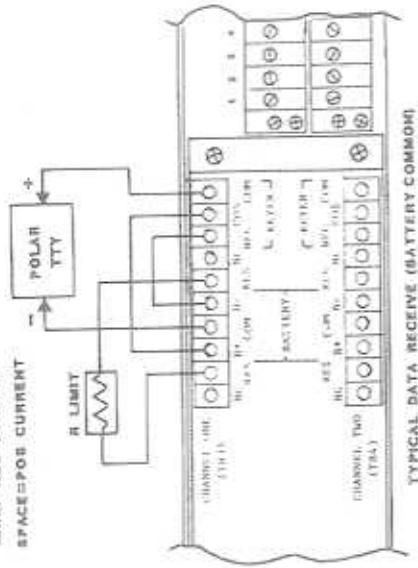

Figure 2-13. Remote Control Application

NOTE:
KEYING VOLTAGE =
±0.5 VDC TYPICAL
MARK=NEG CURRENT
SPACE=POS CURRENT



TYPICAL DATA RECEIVE (BATTERY COMMON)

NOTE:
KEYING VOLTAGE =
+130VDC TYPICAL
(REF: KEYS POSITIVE)

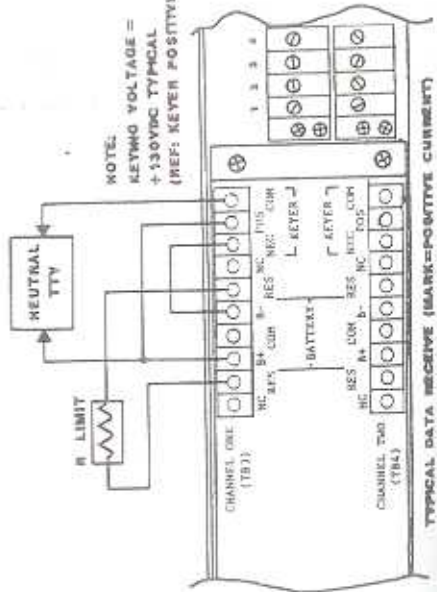

TYPICAL DATA RECEIVE (MARK=POSITIVE CURRENT)

NOTE:
KEYING VOLTAGE =
-130VDC TYPICAL
(REF: KEYS NEGATIVE)

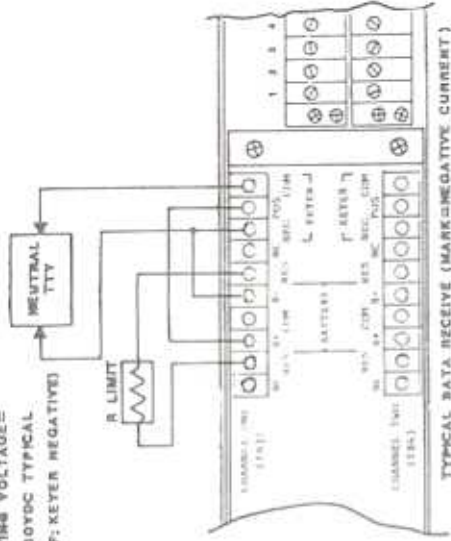

TYPICAL DATA RECEIVE (MARK=NEGATIVE CURRENT)

NOTE:
SHOWN FOR 30MA
OPERATION.
RECOMMENDED
LIMITER RESISTOR IS
5500Ω, 10W. INSURE 30MA
JUMPER IS INSTALLED

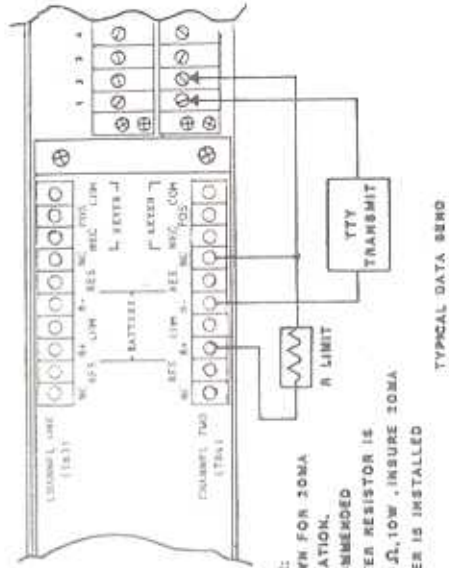

TYPICAL DATA SEND

CAUTION

LOOP CURRENT MUST BE
EXTERNALLY LIMITED TO
80 MA MAX (60 MA TYP)
AND ARC SUPPRESSION TO
LESS THAN 300 VOLTS

2.9.1 Power Supply Checkout

Turn the power switch on. Display descriptors should be illuminated.

2.9.2 Front Panel Keypad and Display Checkout

The Model 1280A can be configured as a modem, a one or two channel modulator, or a one or two channel demodulator. The following procedure pertains specifically to a modem with channel one as a demodulator and channel two as a modulator. If your unit has one or two modulators (Dual Mod), follow the "Modulator" procedure for the applicable channel (single modulator) or both channels (Dual Mod). If your unit has one or two demodulators (Dual Demod), follow the "Demodulator" procedure for the applicable channel (single demodulator) or both channels (Dual Demod).

The front panel plasma display is capable of indicating channel number, baud rate, mark and space frequencies, channel function, keying type, output polarity, AMH, hold, +.5 Hz function, synchronize mode, regenerative mode, and mark only and space only mode when entered from the keypad. Refer to Section III for the function of each key and display.

N O T E

The "ENTER" LED illuminates when the parameters are keyed in. After each key or series of key entries, the "ENTER" key must be pressed to accept the entry and before any other key entries are made. The only exceptions to this rule are channel selections and remote selection.

Demodulator

- a. Press 'CHAN' (channel) and '1' keys on keypad. Observe descriptor beside DEMOD illuminates on display; and digit 1 appears below CH on display.
- b. Press 'FSK' on keypad. Observe FSK descriptor illuminates on the display. (The 'FSK' descriptor may already be illuminated, depending on the state of the equipment when received.)
- c. Press 'AMH' (AMH) on keypad. Observe AMH descriptor illuminates on display.
- d. Press '2ND' and 'REV' (Reverse) on keypad. Observe REV descriptor illuminates on display.

FREDERICK ELECTRONICS

- e. Press 'BAUD RATE', '7', and '4' keys.
Observe the digits 74 appears below BAUD RATE on display.
- f. Press 'SPACE/ONLY' and '1', '3', '1', '7' keys.
Observe the digits 1317 appear below SPACE on display.
- g. Press 'MARK/ONLY' and '1', '2', '3', '2' keys.
Observe the digits 1232 appear below MARK on display.
- h. Press '2ND' (second function) and '5/+.5' keys.
Observe +.5 descriptor illuminates on display.
- i. Press '2ND' (second function) and 'HOLD' keys.
Observe HOLD descriptor illuminates on display.
- j. Press '2ND' (second function) and 'SYNCH/REGEN' keys.
Observe REGEN descriptor illuminates on display.
- k. Press '2ND' (second function) and 'SPACE/ONLY' keys.
Observe SP ONLY descriptor illuminates on display.
- l. Press '2ND' (second function) and 'MARK/ONLY' keys.
Observe MK ONLY descriptor illuminates and SP ONLY extinguishes on display.
- m. Press 'SYNCH/REGEN' key on the keypad twice.
Observe that the display extinguishes, except that the channel number and L-5 appear below the mark label on the display.
- n. Press the 'CLEAR' key.
Observe that the normal display is restored.
- o. Reset all parameters to an "OFF" state as follows.
(Remember to press the 'ENTER' key after each key selection. The new condition will not be selected until this is done. Ensure that the associated descriptor on the display extinguishes after each entry.)

Press 'FSK'
Press 'AMH/HOLD'
Press 'NORM/REV'
Press '2nd' and 'SYNCH/REGEN'
Press '2nd' and 'AMH/HOLD'
Press '2nd' and '5/+.5'

Modulator

- a. Press 'CHAN' (channel) and '2' key on the keypad.
Observe MOD descriptor illuminates on display and digit 2 appears below CH on the display.
- b. Press 'MUTE' key on the keypad.
Observe MUTE key LED and the ENTER key LED illuminates.

- c. Press 'ENTER' key on the keypad.
Observe ENTER key LED extinguishes.
- d. Press 'MUTE' key on the keypad.
Observe MUTE key LED extinguishes and the ENTER key LED illuminates. Press the 'ENTER' key on the keypad.
- e. Press '2nd' and 'NORM/REV' keys on the keypad.
Observe that the REV descriptor on the display illuminates.
- f. Press '2nd' and 'AMH/HOLD' keys on the keypad.
Observe that the HOLD descriptor on the display illuminates.
- g. Press 'MARK/ONLY', '1', '0', '0', and '0' keys on the keypad. Press 'SPACE/ONLY', '1', '2', '0', and '0' keys on the keypad. Press 'FSK' on the keypad.
Observe that the FSK descriptor on the display illuminates.
- h. Reset all parameters to an "OFF" state as follows.
(Remember to press the 'ENTER' key after each key selection. The new condition will not be selected until this is done. Ensure that the associated descriptor on the display extinguishes after each entry.)

 Press 'FSK'
 Press 'NORM/REV'
 Press '2nd' and 'AMH/HOLD'
- i. Press 'REMOTE' key on the keypad.
Observe that the REMOTE key LED is illuminated.

N O T E

Whenever the unit is in the Remote mode (Remote LED illuminated), the unit is operable from a remote device ONLY. The keypad is disabled.

- j. Verify that the keypad is inoperative when the REMOTE LED is illuminated. Attempt to select Channel 1 (press 'CHAN' and '1').
Observe that channel 1 has not been selected.
- k. Press 'REMOTE' key on the keypad.
Observe REMOTE LED is extinguished.
- l. Press 'CHAN' and '1' on the keypad.
Observe '1' appears below CHAN on the display.

2.9.3 Remote Control Verification

This procedure verifies the operation of the modem from a remote terminal (RT). An RT is any device that transmits and receives serial, asynchronous, digital messages. The digital messages consist of one start bit, eight data bits (ASCII characters), no parity, and two stop bits. When remote operating parameters are entered into the Model 1280A, the front panel display changes to reflect the entered operating parameters. A status report occurs when requested from the RT or when an input error is recognized by the modem.

- a. Connect the RT to REMOTE I/O on the rear panel of the Model 1280A. Refer to Table 2-1 or 2-4 for pin connection assignments.

N O T E

The RT must be RS-232 compatible.

- b. The CHANNEL ADDRESS switch S1 on the control board is set at the factory to 01. Ensure that the SW is set to 01. Refer to Section 2.7.1 for an explanation of the CHANNEL ADDRESS switch settings.
- c. Verify the BAUD RATE selection jumper on the control board is compatible for the RT in use (set at the factory to 9600 baud). Refer to Section 2.7.1 for an explanation of the BAUD RATE jumper settings.
- d. Perform each input command listed in Table 2-5 from the RT. Observe status and Model 1280A response.

Table 2-5. Remote Control Verification

INPUT COMMAND	MODEM RESPONSE
C01R1 (CR)	REMOTE key LED illuminates. DEMOD descriptor illuminates, digit 1 appears below CH on display.
J0 (CR)	FSK descriptor illuminates.
J1 (CR)	MK ONLY descriptor illuminates. FSK descriptor extinguishes.
J2 (CR)	SP ONLY descriptor illuminates. MK ONLY descriptor extinguishes.
A1 (CR)	AMH descriptor illuminates.
A0 (CR)	AMH descriptor extinguishes.
N1 (CR)	REV descriptor illuminates.
N0 (CR)	REV descriptor extinguishes.
B0600 (CR)	Digits 600 appear below baud rate on display.
S1575 (CR)	Digits 1575 appear below SPACE on display.
M2425 (CR)	Digits 2425 appear below MARK on display.
E1 (CR)	+.5 Hz descriptor illuminates on display.
E0 (CR)	+.5 Hz descriptor extinguishes.
H1 (CR)	HOLD descriptor illuminates on display.
H0 (CR)	HOLD descriptor extinguishes.
*D1 (CR)	DIV key LED illuminates.
*D0 (CR)	DIV key LED extinguishes.
Y1 (CR)	REGEN descriptor illuminates on display.
Y0 (CR)	REGEN descriptor extinguishes.

*These commands apply only to a unit with two DEMOD boards.

Table 2-5. Remote Control Verification (cont.)

INPUT COMMAND	MODEM RESPONSE
W0 (CR)	SYNCH descriptor illuminates on display.
W5 (CR)	SYNCH descriptor extinguishes.
C02B0600 (CR)	MOD descriptor illuminates, digit 2 appears below CH on display, and digits 600 appear below baud rate.
U1 (CR)	MUTE key LED illuminates.
U0 (CR)	MUTE key LED extinguishes.

SECTION III

OPERATION

3.1 GENERAL

This section contains an explanation of the controls and display indicator elements used in the operation of the Model 1280A FSK MODEM. It also describes the location and function of each element, control input and status output in the operation of the Model 1280A from a remote control device, and operating procedures for the Model 1280A.

3.2 CONTROLS AND DISPLAY INDICATOR ELEMENTS

The Model 1280A can be controlled by the front panel keypad. The keypad numeric and function keys are used to set up specific operating parameters. Some keys are dual function keys. For example, numeric "5" key also selects "+.5 Hz." To select the latter function, the "2nd" key has to be pressed before the 5/+.5 key is pressed. Specific keys contain LEDs that indicate the state of the Model 1280A.

The front panel indicator element displays the state of the controlled channel(s) via bargraph displays, descriptor lights, and digital read-outs of frequency, baud rate, and channel selected.

Functional descriptions of the display element, keypad, and power switch are given in Table 3-1. Figure 3-1 is a front panel view of the controls and indicators by item number.

Table 3-1. Controls and Indicators

ITEM	INDICATOR/CONTROL	DESCRIPTION
1	<p><u>Display Elements</u></p> <p>MARK Bar Graph</p> <p>SPACE Bar Graph</p> <p>SYNCH Descriptor</p> <p>MOD Descriptor</p> <p>DEMODO Descriptor</p> <p>MK ONLY Descriptor</p> <p>AMH Descriptor</p> <p>SP ONLY Descriptor</p> <p>HOLD Descriptor</p> <p>REV Descriptor</p> <p>+ .5 Hz Descriptor</p> <p>BAUD Rate</p> <p>CH</p> <p>SPACE</p> <p>MARK</p> <p>FSK</p> <p>REGEN</p>	<p>Indicates Mark tone input/filter output signal strength in dBm.</p> <p>Indicates Space tone input/filter output signal strength in dBm.</p> <p>Indicates channel in Synchronous mode when illuminated or Asynchronous mode when extinguished.</p> <p>Indicates channel is a Modulator.</p> <p>Indicates channel is a Demodulator.</p> <p>Indicates channel is in Mark Only mode.</p> <p>Indicates AMH selected.</p> <p>Indicates channel is in Space Only mode.</p> <p>Indicates channel is in Hold (standby) condition.</p> <p>Indicates channel output is in Reverse polarity.</p> <p>Indicates channel frequencies selected in .05 Hz increments.</p> <p>Indicates selected baud rate.</p> <p>Indicates selected Channel is 1 or 2.</p> <p>Four-digit display indicating Space tone frequency.</p> <p>Four-digit display indicating Mark tone frequency.</p> <p>Indicates FSK function selected.</p> <p>Indicates regenerated data mode selected.</p>

Table 3-1. Controls and Indicators (cont.)

ITEM	INDICATOR/CONTROL	DESCRIPTION
2	<p><u>Keypad Controls</u></p> <p>CHAN X</p> <p>AMH/HOLD</p> <p>DIV</p> <p>FSK</p> <p>BAUD RATE XXXX</p> <p>NORM/REV</p> <p>MUTE</p>	<p>Enables channel selection and control where X is numerical key 1 or 2.</p> <p>AMH - Selects or removes AMH function (Demod only).</p> <p>2nd-HOLD - Selects or removes Hold (STAND-BY) function.</p> <p>Selects or removes diversity of controlled channel with adjacent channel (Dual Demod configuration only).</p> <p>Selects or removes FSK Function of frequency shifts 200 Hz and below for modulator.</p> <p style="text-align: center;">N O T E</p> <p style="text-align: center;">Anytime a shift above 200 Hz is selected, the unit defaults to FEK mode.</p> <p>Enables selection of baud rate where XXXX are the four numerical keys.</p> <p>Selects Normal or Reverse output polarity.</p> <p>Selects or removes modulator Mute function; when selected, mute descriptor illuminates (Mod only).</p>

FREDERICK ELECTRONICS

Table 3-1. Controls and Indicators (cont.)

ITEM	INDICATOR/CONTROL	DESCRIPTION
2	<u>Key Pad Controls</u> (cont.)	
	MARK/ONLY	MARK XXXX - Enables selection of mark tone frequency for selected channel where XXXX are the four numerical keys specifying frequency in hertz.
		2nd Mark Only - Places selected channel in the Mark Only mode (Demod only).
	CLEAR	Clears operating parameters prior to pressing 'ENTER' Key.
	SYNCH/REGEN	Selects or removes selected channel in the synchronous regenerated data mode (Demod only).
	REMOTE	Enables or disables modem for remote control function; when selected descriptor illuminates, it is enabled.
	SPACE/ONLY	Space XXXX - Enables selection of Space tone frequency of selected channel where XXXX are the four numerical keys specifying frequency in hertz.
		2nd Space Only - Places selected channel in the Space Only mode (Demod only).
	2ND	Enables selection of 2nd functions for selected channel.
	1	Selects numeric 1.
	2	Selects numeric 2.
	3	Selects numeric 3.
4	Selects numeric 4.	

Table 3-1. Controls and Indicators (cont.)

ITEM	INDICATOR/CONTROL	DESCRIPTION
2	<p><u>Key Pad Controls</u> (cont.)</p> <p>5/+5</p> <p>6</p> <p>7</p> <p>8</p> <p>9</p> <p>0</p> <p>ENTER</p>	<p>5 - Selects numeric 5.</p> <p>2nd +.5 - Selects 0.5 Hz increment for Mark and/or Space frequencies.</p> <p>Selects numeric 6.</p> <p>Selects numeric 7.</p> <p>Selects numeric 8.</p> <p>Selects numeric 9.</p> <p>Selects numeric 0.</p> <p>Enters selected parameters to initiate control of the selected channel. Descriptor illuminates whenever a channel function is selected and extinguishes when parameters are entered.</p>
3	POWER	ON/OFF switch to provide unit power.
4	OUTPUT LEVEL ADJUSTMENT	Allows adjustment of modulator output level from front panel.