



DATA TECHNOLOGY ASSOCIATES, INC.
P.O. BOX 431912
MIAMI, FLORIDA 33143

DT-600

TELETYPE DEMODULATOR

TABLE OF CONTENTS

- SECTION I - INTRODUCTION
- SECTION II - THEORY OF OPERATION
- SECTION III - CONSTRUCTION TIPS
- SECTION IV - CHECKOUT AND ALIGNMENT

Data Technology Associates, Inc. reserves the right to discontinue products or to change specifications at any time without incurring any obligation to incorporate new features in products previously sold.

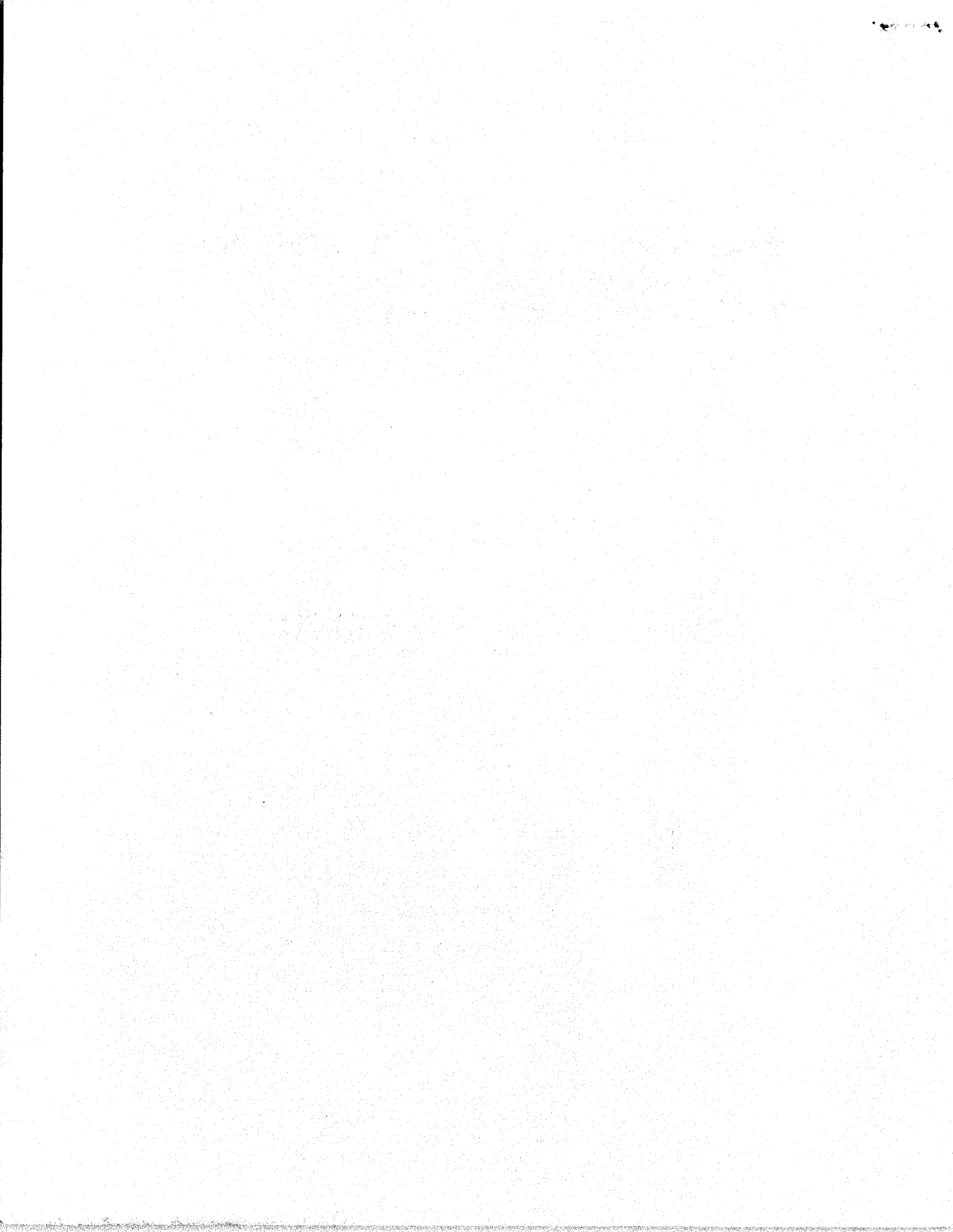

I M P O R T A N T

N O T I C E

The edge connector pin numbers referred to in the February 1976 issue of Ham Radio magazine which described the DT-600 were in error. The DT-600 is laid out for a 22 pin connector. The article describes pin numbers as high as 26. For your use in interpolating between the information given in the article and the data enclosed, we have prepared a conversion chart to cross reference the incorrect pin numbers with the edge connector numbers actually found on the DT-600 board.

Magazine Article Pin Numbers	Correct Pin Numbers	Function
1	3	Audio Input
2	2	Ground
3	4	Limiterless
4	9	Limiterless
5	6	Scope (Mark)
6	7	Scope (Space)
7	13	Data Output
8	12	Loop Keying
13	15	Print/Non-print (Data Flag)
14	18	Standby
15	17	Autostart Normal/Fast
16	20	Motor Automatic/On
18	21	Motor Control Relay
22	10	Tuning Meter
23	8	+12 Volts
24	22	Ground
25	5	-12 Volts
26	19	Autostart Normal/Off

It is not possible to lay out a circuit board that exactly matches the parts in your junk box. We at Data Technology Associates have laid out this board for modern circuit board components, readily available from large electronic suppliers. In cases where several manufacturers make suitable components, we have not listed specific part numbers.

SECTION I

INTRODUCTION

1.1 PURPOSE OF EQUIPMENT

The DT-600 RTTY Demodulator is designed to provide high performance detection of frequency shift keying signals. Accepting audio signals from a communications receiver, the DT-600 demodulates these signals and uses the resultant output for keying a standard 20 ma. or 60 ma. teletype loop or one or more TTL logic level devices. The effects of frequency selective fading are minimized through the use of a wide dynamic range limiter and an automatic threshold correction circuit.

In addition, the DT-600 provides a proven autoprnt system which discriminates against voice and C.W. signals. An anti-space circuit guards against steady signals in the space channel which cause the bothersome "open loop" condition in many demodulators of lesser quality. Full TTL logic interface and controllability are provided to facilitate easy interconnection with a wide variety of control and signaling devices.

Using single circuit board construction, the DT-600 is designed to provide optimum performance and features with minimum parts count.

1.2 PHYSICAL DESCRIPTION

The DT-600 RTTY Demodulator is contained on a single 4.50" by 6.50" (11.43 cm. by 16.51 cm.), double-sided plug-in circuit board suitable for mounting in a wide variety of enclosures.

1.3 ELECTRICAL SPECIFICATIONS (Amateur Standard)

Input

Impedance	Unbalanced 500-600 Ohms
Input Signal Level	0.2 to 10.0 Volts
Baud Rate	45 to 75 Baud
Frequency Shift	170 or 850 Hz

Bandpass Filter Bandwidth (-3 DB) (Toroidal Inductors)

850 Hz Shift	1100 Hz typical
170 Hz Shift	260 Hz typical

Bandpass Filter Bandwidth (-3 DB) (Pot Core Inductors)

850 Hz Shift	*
170 Hz Shift	*

Discriminator Filters

850 Hz Shift	MARK	2125 Hz
	SPACE	2975 Hz

REV 1

Discriminator Filters (cont.)

170 Hz Shift MARK 2125 Hz
SPACE 2295 Hz

Autostart Characteristics

Turn-On Time NORMAL 3-5 Seconds
FAST 1-2 Seconds

Mark-Hold Lock-up Time 1 Second

Motor Turn-Off Time 30 Seconds (nominal)

Outputs

Mark/Space Data

Standard 20 ma. or 60 ma. Teletype Loop Keyer (external current limiter)

Open-Collector NPN Transistor (Pulls down (ON) on MARK, up (OFF) on SPACE)

Autostart (Autoprint)

Open-Collector NPN Motor Control Relay Driver Transistor

Data Flag

Open-Collector NPN Transistor (Pulls down (ON) when no data, up (OFF) when data is present)

Power Requirements

+12 Volts DC at 38 ma. (Does NOT include motor relay current which does not have to be regulated.)

-12 Volts DC at 21 ma.

External Loop Supply, 70 to 180 volts at 20 ma or 60 ma

* Pot Core Bandwidth Characteristics

The Q and therefore the bandwidth of pot core inductors is a function of the type of ferrite material used in the core. Following are the characteristics of two pot core types presently under evaluation for use with the DT-600. (Note - the higher the Q, the better the bandwidth characteristics).

Type Inductor	L(MH)	"Q" at	1.0	2.0	2.2	2.4	2.6	2.8	3.0	KHz
Surplus Toroid	88		13	56	69	88	92	115	128	
Pot Core #1	88		65	300	325	375	400	475	500	
Pot Core #2	88		95	325	400	475	500	600	700	

SECTION II

THEORY OF OPERATION

2.1 PURPOSE

For those who are not proficient in solid state electronics, we offer this "simplistic" description of the operation of the DT-600 RTTY Demodulator. This Section is designed to supplement rather than replace the higher level theory of operation presented in the Ham Radio article. For this reason, this will not be a technically precise description. All voltage indications are approximations provided to help the non-professional builder understand the DT-600.

Should there be a problem with the DT-600, this section should be valuable in helping to isolate and correct the problem.

The DT-600 consists of several simple interconnected modules. It is possible to isolate and independently test most of these modules, a feature which eases the task of corrective maintenance.

2.2 BANDPASS FILTER

The Bandpass Filter circuit consists of R-1 thru R-6, D-1, D-2, L-1 thru L-3, and C-1 thru C-6.

This particular configuration of the 3-pole Butterworth bandpass filter family has been popular with amateurs for many years because of its simplicity and ease of tuning. The three "equivalent" tuned sections of this filter consist of the following parallel combinations:

- | | |
|-----------------------------|---|
| (1) L-1, C-1, C-2, C-7 | Note that the coupling capacitors become part of the adjacent tuned circuits. |
| (2) L-2, C-7, C-3, C-4, C-8 | |
| (3) L-3, C-8, C-5, C-6 | |

Resistor pairs R-1/R-2 and R-3/R-4 help in impedance matching while D-1 and D-2 limit the input voltage to U-1 to plus/minus 0.7 volts. R-5 is used only in the A.M. (limiterless) mode as a feedback resistor across U-1. This feedback causes U-1 to operate with decreased gain so that it will not limit on incoming signals.

There has been a lot of information on Butterworth filters and toroid tuning techniques in various amateur radio publications since 1966 should further reading be desired. Among others, we recommend the following:

- QST, May 1966, "Checking RTTY Shifts" by Hoff
- QST, August & September 1966, "High Performance RTTY Filters" by Hoff
- CQ, November & December 1966, "The Butterworth Filter Cookbook" by Lancaster
- QST, September 1968, "Inductance and Q of Modified Surplus Toroidal Inductors" by Weatherford

2.3 LIMITER

The Limiter circuit consists of U-1, R-7 thru R-13, and C-9 thru C-13. A single 709 op amp is used as U-1 in an open-loop configuration for maximum gain in all but the Limiterless mode. For this purpose the 709 is superior to the 741 but requires decoupling from the DC power busses, frequency compensation, and latch-up protection. The principle purpose of the Limiter circuit is to accept

a wide range of input signal levels from the Bandpass Filter and amplify them to the point of amplifier saturation. This provides hard limiting on the output of U-1 at approximately plus/minus 10 volts for about an 80-90 DB swing in the input signal level. This constant level output helps the Discriminator/Detector do its job and provides for reliable autostart operation.

The A.M. (limiterless) mode of operation is the one exception to the above circuit configuration. By connecting card edge connector Pins 4 and 9 together we place R-5 between the output (pin 6) and the input (pin 2) of U-1. This negative feedback circuit prevents U-1 from saturating (limiting). Instead, it serves simply as a signal amplifier and retains most of the signal variations present in incoming signal. Thus the terms A.M. and limiterless.

2.4 DISCRIMINATOR/DETECTOR

The plus/minus 10 volt square wave output of the Limiter (U-1) is applied through A.C. equalization components R-16 through R-19 to the MARK and SPACE discriminator filters. By grounding the center-tap of the two 88 MHz inductors (L-4 and L-5), two full-wave rectifier (detector) circuits consisting of D-5/D-6 and D-7/D-8 are possible. This results in a very efficient detection system. The MARK detector is configured for a negative voltage output while the SPACE detector is set for a positive output. These voltage outputs are summed and applied to pin 2 of U-2, the first stage of the active Low Pass Filter. Since pin 3 of U-2 is referenced to ground, the output of U-2 follows the plus/minus outputs of the Detector within the limits set by the low pass filter signal bandwidth.

A scope cross pattern which is easier to use for tuning purposes than the tuning meter can be obtained by connecting card edge Pin 6 to the horizontal amplifier input and Pin 7 to the vertical amplifier input with the internal oscilloscope time base turned off.

The functions of D-3, D-4 and C-14 are described in the Autostart section description.

We have made the point elsewhere in this documentation package that we do not consider it worthwhile to take the extra trouble to buy and use 1N270 germanium diodes for D-5 through D-12. We suggested the use of silicon diodes instead. The use of germanium diodes affects the threshold of the discriminator ONLY if signals drop so low that the diode barrier is approached. At the barrier potential of a silicon diode the audio input level is approximately 75 DB lower, or in the neighborhood of 50 MICROVOLTS RMS. This is an unuseable level. Most receivers put out more noise and hum than this with the antenna disconnected. The common misconception is that the ratio between the germanium and silicon thresholds is a measure of improvement ($.6/.3 = 2$ which equates to 3 DB) -- NOT TRUE. It just means that in a noiseless system you would get a 25 microvolt threshold on the input. The op amp itself has an "equivalent" noise input of 25 uv so the entire discussion of germanium versus silicon detection is purely academic. At 80-90 DB limiting we already capture more signal than we can extract information from with a reasonably low error rate.

2.5 LOW PASS FILTER

The Low Pass Filter circuit consists of U-2, U-3, R-22 thru R-27, and C-17 thru C-19.

The RTTY signals that we are interested in have pulse widths on the order of 13.3 ms. (100 WPM) to 22 ms. (60 WPM). Noise and other interference usually

contains pulses or "spikes" of much shorter duration and therefore have a higher frequency content. (We won't get into signal theory but the shorter the pulse and the faster its rise and fall times the higher the frequency content. This is why frequency calibrators put out square waves rich in high frequencies to insure "birdies" throughout the receiver frequency coverage range).

The purpose of the low pass filter is to roll off these high frequency components above the 45 or 75 bits per second rates of interest. This rolloff is adjusted by the values selected for C-17 and R-23 in the two-stage, 3-pole, active low pass filter circuit.

Question often come up on the effect on 60 WPM RTTY of setting this low pass filter at 100 WPM. In actual practice we must say that it will make a little difference but you will have to look long and hard to see it.

Likewise, the question comes up about setting the low pass filter for 60 WPM and then copying 100 WPM occasionally. In this case we lose a little more. Technically, we probably lose the 5th order and following terms in the fourier series which results in about a 3/23 or 13% change in output voltage which does not necessarily correspond directly to an equivalent decrease in performance. If there is a choice, however, we feel much more comfortable using the 100 WPM filter on 60 WPM than the other way around.

2.6 AUTOMATIC THRESHOLD CORRECTOR (ATC)

The ATC circuit consists of D-9 thru D-12, C-20, C-21, R-28 and R-29. One of the problems we run into when operating RTTY on the H.F. bands is called selective fading. Instead of the entire signal fading in and out, only the MARK or SPACE channel will fade. When this occurs we have in effect a strong signal in one channel and a weak or no signal in the other. If we maintain the switch-over threshold at zero volts we have in effect an on/off keying taking place in one channel and either no keying or minimal on/off keying in the other. Obviously in such cases we could obtain more positive keying action and more balanced keying if we could move the threshold closer to the mean of these two signals. The purpose of the ATC circuit is just that, to vary the threshold in accordance with the varying signal conditions prevalent in the MARK and SPACE channels and regulate the threshold for best keying performance. This provides the Slicer with cleaner, more distortion-free signals.

2.7 SLICER/KEYER

Although two independent circuits, the Slicer and Keyer are being treated together since they work in direct conjunction with each other. The Slicer circuit consists of U-4 and R-30 thru R-32. The Keyer consists of Q-1, Q-2, R-33 thru R-35, and D-13 thru D-16.

The symmetrical polar (plus/minus) voltages presented at the output of the ATC circuit are low level and gradually varying. As such, these voltages are not very appropriate for the uniform and expeditious turn-on/turn-off action desired for keying a teletype loop.

The Slicer, because of its high gain, will provide a plus/minus 10 volt swing on its output with only a 1 or 2 millivolt swing on its input. This output turns both Q-1 and Q-2 ON when positive and OFF when negative. D-14 is used to connect the positive voltage outputs of the Standby, Autostart, and Anti-Space circuits into the keyer circuits to force Q-1 and Q-2 ON (MARK-HOLD) regardless of the output of the Slicer. Notice, however, that Q-1 is effected by this MARK-HOLD voltage only if it is connected at the junction of D-13 and R-35 (C to 2) instead of to the output of U-4 (C to 1). Because of this feature, Q-1 (the TTL logic level output) is ideal for providing MARK/SPACE data to selective calling and similar station control equipment.

2.8 STANDBY CIRCUIT

The Standby Circuit consists of Q-4, D-22 thru D-24, R-44 thru R-46, and D-26. The purpose of the Standby Circuit, when card edge connector Pin 18 is pulled down or grounded, is two fold:

- a. The demodulator is forced into a MARK-HOLD condition.
- b. The motor is held on, regardless of whether or not a signal is present.

Let's discuss how these actions take place. As the circuit appears on the schematic with no pull-down on Pin 18, Q-4 is turned ON (saturated - its collector voltage is only a few tenths of a volt. This turn-on path is +12 volts through R-44, D-23 and the base-emitter junction of Q-4). Since the collector of Q-4 is LOW, no current flows through D-24 to place the unit in MARK-HOLD.

On the other hand, when Pin 18 is pulled down, Q-4 is turned off and its collector voltage rises to +12 volts. This voltage applied through D-24 turns on Q-2 (MARK-HOLD condition) and Q-3 (DATA FLAG OFF -- No data present). Also, the pull down on pin 18 pulls pin 3 of U-6 (via D-26) low (and less positive than the fixed positive bias voltage on pin 2 of U-6). The output of U-6 then goes negative, turning off Q-5 and forcing the output of U-7 positive thereby holding the motor relay ON. Refer to the Autostart circuit description in the next few paragraphs for more detail on this action.

2.9 AUTOSTART CIRCUIT

The Autostart Circuit consists of U-5, U-6, R-47 thru R-58, C-24, C-25, and D-25 thru D-27.

Whether there is noise, non-RTTY signals, weak or off-frequency signals, or strong precisely tuned RTTY signals at the input of the demodulator, the relative signal strength captured in the discriminator MARK and SPACE filters is rectified by D-3 and D-4, filtered by C-14, and presented at TP2 and to the Autostart Section. The magnitude of this voltage is lowest with noise (zero with no signal input -- receiver off) and highest when strong perfectly-tuned signals are present. Notice that signals in either the MARK or SPACE channel will produce a positive voltage output.

This output is fed to pin 2 of U-5 where it is compared with a fixed but settable positive bias threshold voltage on pin 3. This bias voltage is really the autostart sensitivity setting and is adjustable by R-50 between approximately 2.2 volts and 3.3 volts.

Before a valid RTTY signal is received, the voltage on pin 3 of U-5 is more positive than the voltage impressed on pin 2 by the incoming signal. The output of U-5 is then approximately +10 volts which in the NORMAL AUTOSTART mode charges C-24 and in the FAST AUTOSTART mode charges both C-24 and C-25 which are then in series. The voltage then on pin 3 of U-6 is approximately 6.2 volts which is higher than the fixed bias voltage of approximately 2.2 volts on pin 2. The output of U-6 is then approximately +10 volts which you will find when reading the next section on the Motor Control circuit turns the motor control relay OFF.

When a signal appears on the input, pin 2 of U-5 is then more positive than pin 3 and the output of U-5 swings to approximately -10 volts thus removing the source of charging voltage to C-24 (and C-25). C-24 (and C-25) then begin to discharge through the series combination of R-54 and R-55. This RC time constant circuit determines the autostart turn-on time. Notice then the subtle

difference between autostart sensitivity and turn-on time. Basically, sensitivity regulates when the autostart will begin to react and the RC time constant circuit regulates how long it will take. Such time constant circuits take longer when the resistance or capacitance is increased, shorter when they are decreased. In the NORMAL AUTOSTART mode when card edge Pin 17 is grounded we have 22 uf (or 18 uf -- see Parts List for more info). In the FAST AUTOSTART mode we have only 3.9 uf (4.7 uf in series with 22 uf), and thus a shorter turn-on time.

From the initial charge of approximately +9.3 volts (+10V output of U-5 less drop across D-25) on C-24 (and C-25), approximately 3-6 seconds (1-2 seconds in FAST AUTOSTART mode) is required to discharge down to approximately +3.6 volts at that time, because of the voltage divider arrangement of R-54 and R-55, the voltage on pin 3 of U-6 drops below the fixed bias voltage of +2.2 volts on pin 2 and the output of U-6 swings negative. As indicated in the Motor Control section to follow, this turns the motor relay on.

We can force the autostart turn-on in two ways. Notice in the above paragraph that the voltage on pin 3 of U-6 went lower than that on pin 2 for motor turn-on. By physically pulling pin 3 down using card edge connector Pin 19 (FORCE ON) or Pin 18 (STANDBY) via D-26, the motor will be forced on.

2.10 MOTOR CONTROL

The Motor Control circuit consists of U-7, Q-5, Q-6, C-26, R-59 thru R-64, and D-28 thru D-30.

No Signal Condition (Steady State)

When no valid signal is present on the input of the demodulator, the output of U-6 is positive and Q-5 is turned on (collector voltage is a few tenths of a volt). Capacitor C-26 is discharged and the voltage on pin 2 of U-7 is more positive (approx. +2.2 volts fixed bias) than that on pin 3. The voltage at the output of U-7 is negative. Therefore, Q-6, the motor control relay driver transistor, is OFF.

Valid Signal

After a few seconds of valid signal, the output of U-6 becomes negative which turns Q-5 off. As soon as Q-5 turned off, C-26 quickly charges to approximately +11.3 volts through R-60. With pin 3 of U-7 at approximately +11.3 volts (and more positive than the +2.2 volts fixed bias on pin 2), the output of U-7 is positive and Q-6, the motor control relay driver transistor, is ON.

Loss of Signal

The important part of the motor control circuit occurs when the signal disappears and the output of U-6 goes positive. Q-5 is immediately turned on and its collector voltage drops to a few tenths of a volt thereby removing the charging voltage source to C-26. The delay in motor turn-off is then determined by the length of time it takes C-26 to discharge through R-61 from approximately +11.3 volts down to just below the +2.2 volt fixed bias on pin 2 of U-7. With 18 uf for C-26 and 1 Meg for R-61 this takes about 30 seconds. The time can be shortened by reducing either component value, preferably the capacitance. Once pin 3 is less positive than pin 2, the output of U-7 swings negative and the motor control relay turns off.

Forced Turn-Off

One excellent feature of the DT-600 is available at card edge connector Pin 20 (which is connected to the collector of Q-5). A switch, transistor collector, or open-collector TTL package pull-down on Pin 20 will force the control circuit to time out (30 seconds) and turn the motor off regardless of whether a signal is present or not. This feature is especially useful for selective calling applications.

2.11 ANTI-SPACE CIRCUIT

The Anti-Space Circuit consists of U-8, Q-7, R-65 thru R-72, C-27, and D-32 thru D-34.

During a MARK condition when the output of the Slicer swings positive, Q-7 is turned on. Conversely, during SPACE the output of the Slicer swings negative and Q-7 is turned off. Each time Q-7 turns on (MARK), C-27 is quickly discharged through R-70. During each SPACE condition when Q-7 is off and its collector rises to approximately +12 volts, C-27 slowly charges through R-71 and R-72. If this steady SPACE condition is maintained for approximately 130 ms., the voltage across capacitor C-27 will rise to the point (approximately +5.5 volts) where pin 3 of U-8 is more positive than the fixed voltage on pin 2 (approx. +2.5 volts) at which time the output of U-8 swings positive and causes two things to happen:

a. This positive voltage through D-33 and D-14 forces the demodulator into MARK-HOLD.

b. Through D-32 the positive voltage charges C-24/C-25, drives the output of U-6 positive, and turns off Q-5. This has the same effect as signal loss and the nominal 30 second motor shut-off delay begins as C-26 discharges through R-61.

If the steady SPACE condition continues for approximately 30 seconds, the motor will shut off since the output of U-7 will swing negative as soon as C-26 has discharged to the point where pin 3 is less positive than pin 3 of U-7.

If the motor is initially off, the autostart will not turn on with steady SPACE. It will turn on with steady MARK or normal teletype signals.

Obviously, if U-8 fails so that its output is always positive, the demodulator will remain in a MARK-HOLD condition and the motor will stay off until this condition is rectified.

We know of no occasion where it would be desirable to disable the anti-space circuitry other than in the case of failure of the U-8 circuitry while awaiting parts. Should this be the case, however, the anti-space circuit can be disabled by removing D-32 and D-33 (just unsolder one end of both of them).

SECTION III

CONSTRUCTION TIPS

3.1 THE DT-600 CIRCUIT BOARD

Extra time spent in the careful selection and soldering of components to the circuit board will be time well-spent. These two actions are most important in insuring a product which will work the first time and deliver many years of trouble-free service.

For the purpose of discussions herein, we will refer to either the component side of the circuit board or to the foil side, even though foil patterns are present on both sides of the board. All components mount on the component side where the card edge pins are numbered 1 through 22. The components are soldered in place on the foil side, where the pins are numbered from A through Z. The holes in the board are plated through with approximately .001" of metal thereby connecting the foil on opposite sides of the board together. For this reason, soldering is necessary only on the foil side of the board.

All foil surfaces have been solder plated for ease in soldering. For this reason, less heat should be necessary. Solder plating is superior to the tin plating so often found on hobbyist boards since tin plating tends to oxidize after a few days. This oxidation must be removed if a good solder bond is to be obtained either by burnishing before soldering or by the application of excessive heat during the soldering process.

3.1.1 SOLDERING HINTS

Most people are aware of the dangers of overheating when soldering solid state components. In this regard, a few recommendations are in order:

A. Use a 20-50 watt pencil iron (rather than a soldering gun or high wattage iron). If such an iron is not available and you intend to do a lot of building, it may be advisable to invest in one.

B. Use only rosin core solder with a tin-lead content of either 60:40 or 50:50. (60:40 is the preferred composition ratio).

C. When soldering integrated circuits (IC's), pots, transistors or diodes, allow pins to cool before soldering another pin on that device as the heat tends to be cumulative. Actually, this habit is not a bad one for ANY component. Clip-on heat sinks are worthwhile if available. The idea in any case is to get on, solder a good joint, and "get off".

D. It is also possible to change resistance values, damage capacitors, or even damage the circuit board itself if too much heat is applied. Circuit board damage is VERY prevalent when unsoldering. Therefore, use care and patience in soldering (or unsoldering) all connections, not just in the fragile areas.

E. If you do make a mistake, removal of components is generally easier using "Solder-Wick" (a G. C. Electronics product) than with most desoldering tools.

REV 1

DT-600

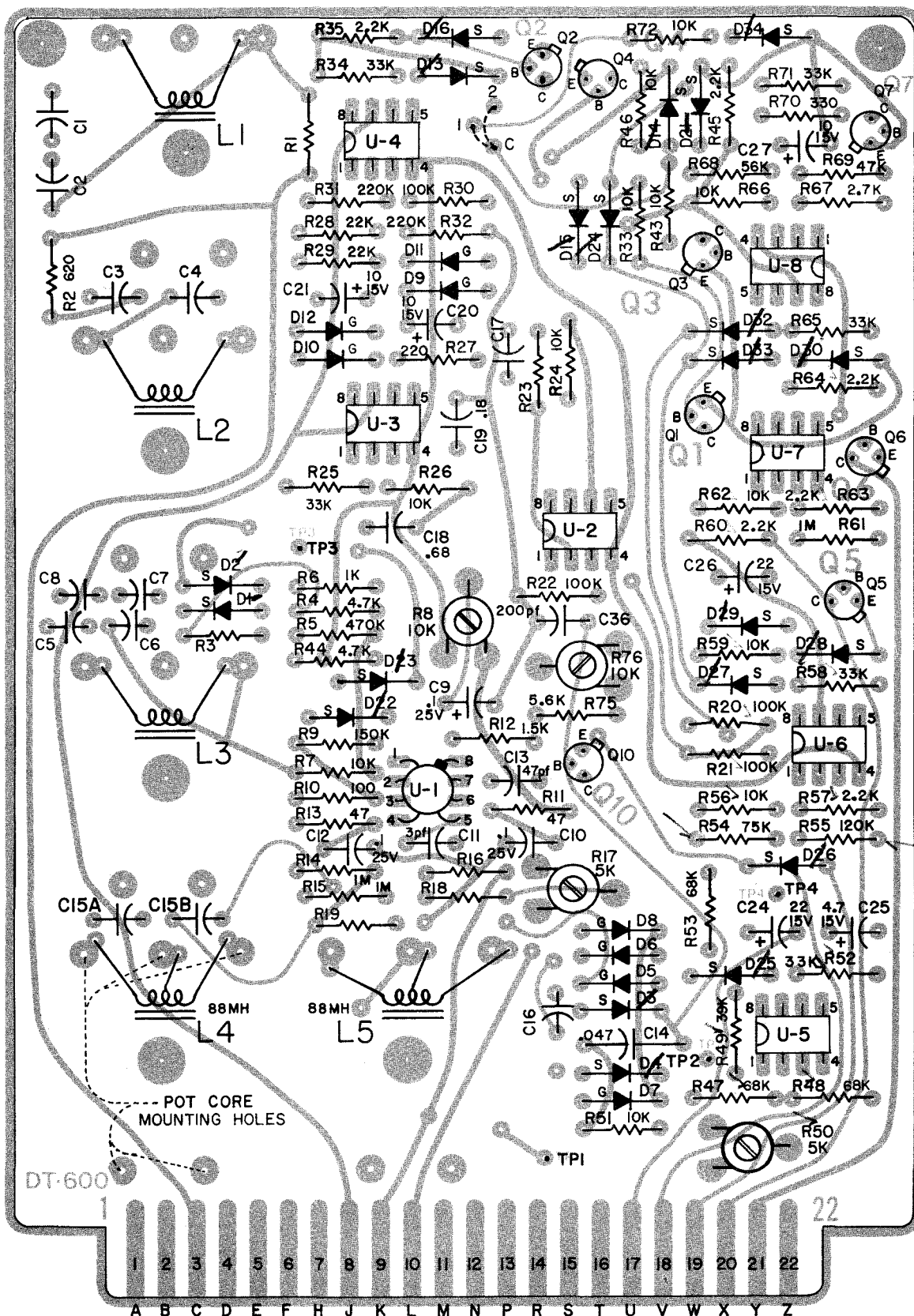

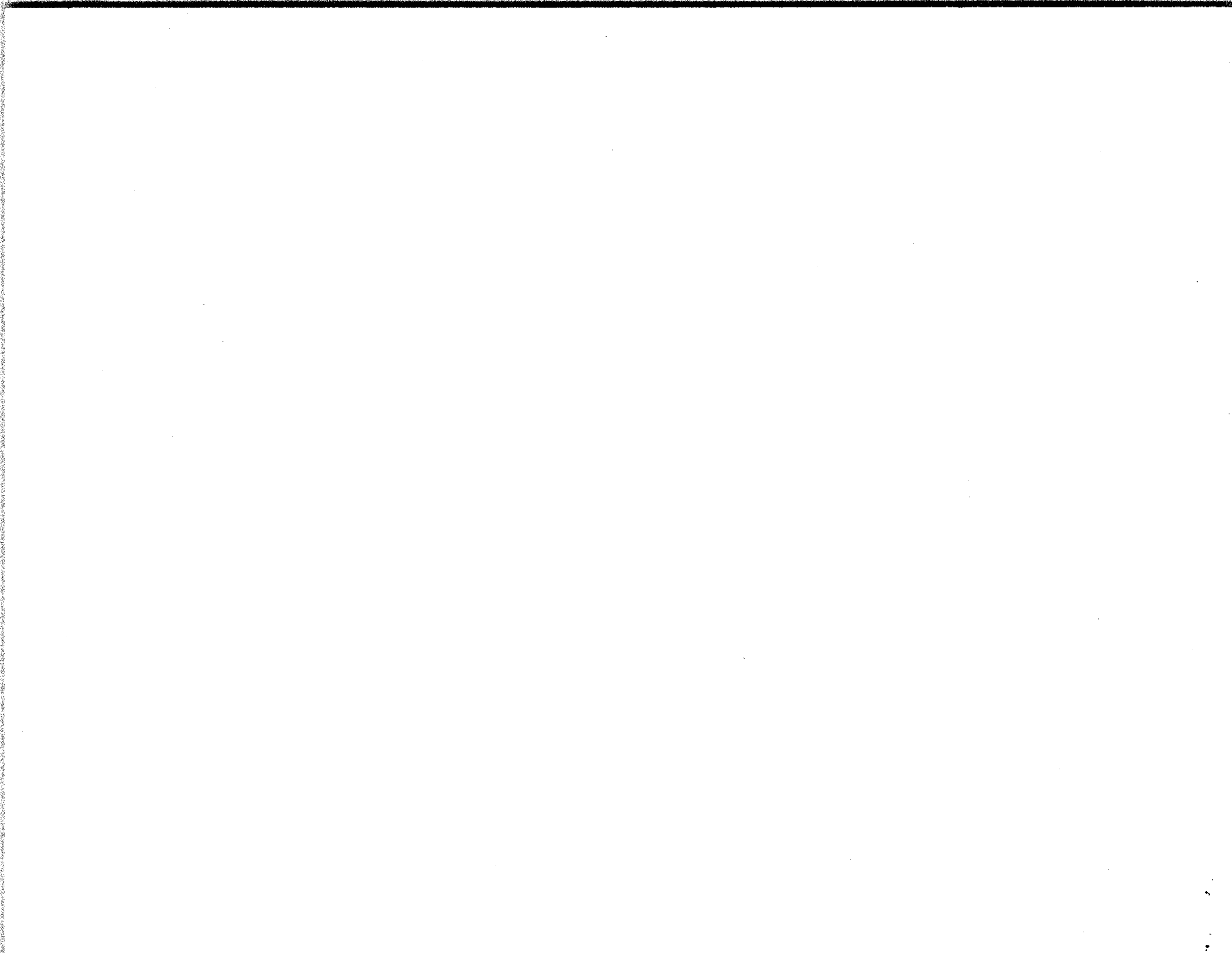

3.1.2 LOADING THE BOARD

NOTE - Refer to the component layout pictorial, Figure 3-1, for component placement.

Resistors:

Recommend placing the resistors on the board first. Be careful to place all resistors in their proper locations as it is a lot easier to be right the first time than to move them once they have been soldered in place. This is, of course, true of all components. Note that R-1 will probably be mounted off the board.

Although not necessary, a neater appearance will be obtained if all resistors are oriented in the same direction; i.e., banded end of all resistors either to the left or upward as appropriate. This also helps in reading the color codes.

Note that the resistors used in the discriminator are different for 170 Hz shift and 850 Hz shift. The following chart, identical to that on the large DT-600 schematic, is provided for convenience.

Resistor	2125/2295	2125/2975
R16	6.8K	4.7K
R18	6.8K	6.8K
R19	100K	33K
R23	270K	180K

Here is a ready reference for the color codes of all resistors used in the construction of the DT-600 board:

Resistance	Color Code
47	YELLOW-VIOLET-BLACK
100	BROWN-BLACK-BROWN
220	RED-RED-BROWN
330	ORANGE-ORANGE-BROWN
470	YELLOW-VIOLET-BROWN
620	BLUE-RED-BROWN
1K	BROWN-BLACK-RED
1.5K	BROWN-GREEN-RED
1.6K	BROWN-BLUE-RED
2.2K	RED-RED-RED
2.7K	RED-VIOLET-RED
3.3K	ORANGE-ORANGE-RED
4.7K	YELLOW-VIOLET-RED
5.6K	GREEN-BLUE-RED
6.8K	BLUE-GREY-RED
10K	BROWN-BLACK-ORANGE
22K	RED-RED-ORANGE
33K	ORANGE-ORANGE-ORANGE
39K	ORANGE-WHITE-ORANGE
47K	YELLOW-VIOLET-ORANGE
56K	GREEN-BLUE-ORANGE
68K	BLUE-GREY-ORANGE
75K	VIOLET-GREEN-ORANGE
100K	BROWN-BLACK-YELLOW
120K	BROWN-RED-YELLOW
150K	BROWN-GREEN-YELLOW
180K	BROWN-GREY-YELLOW
220K	RED-RED-YELLOW
270K	RED-VIOLET-YELLOW
470K	YELLOW-VIOLET-YELLOW
1 MEG	BROWN-BLACK-GREEN

Diodes:

Once the resistors have been mounted, mount all diodes EXCEPT D-32 and D-33 making sure to observe polarity. Also, be sure to place silicon and germanium diodes in their proper places (See Note 3 in the Parts List). Below are shown some equivalent diode markings:

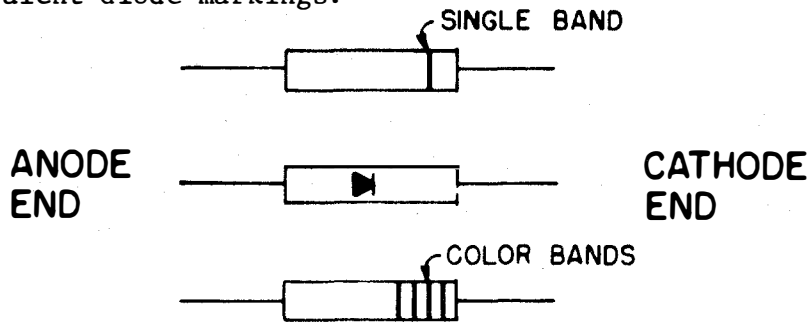

FIGURE 3-2

NOTE - D-32 and D-33 will be mounted during the initial checkout procedures described in Section IV. Also, there is no place on the board for D-31 since that mounts directly across the Motor Control Relay, K-1.

Potentiometers:

Next, mount the two 5K and two 10K potentiometers on the board. DO NOT OVERHEAT.

Transistors:

All useable transistors, especially Q2, may not have the metal case with tab to indicate the emitter lead as shown on the layout drawing. In any case, be very careful to mount all transistors with their emitter, base and collector leads oriented as shown on the component layout.

Operational Amplifiers:

Orient the leads of U-1, the 709, as shown on the component layout. Note that the tab is above pin 8 of the OP AMP.

Mount the 741 mini-dip packages as shown. Notice that U-8 is oriented in a direction opposite that of the other packages.

Capacitors:

Mount all capacitors except C-1 through C-8 and C-15 through C-16 on the board. These remaining capacitors will be mounted after the filters are tuned. Be sure to observe polarity, especially with the tantulum capacitors.

Note that C-17 is .012 ufd for 170 Hz shift and .018 for 850 Hz. Also, we recommend the use of 18 ufd for C-24 and C-26 vice 22 ufd indicated on the schematic and in the article.

Toroids or Pot Cores:

The toroidal or pot core inductors will not be mounted at this time. They will be mounted after the filters are tuned.

3.2 FILTER TUNING TEST SET-UP

Figure 3-3 depicts the recommended test set-up for filter tuning. The resistor is necessary to isolate the tuned circuit from the low output impedance of the audio signal generator. Although not critical, a resistor of approximately 100K ohms is recommended for this purpose.

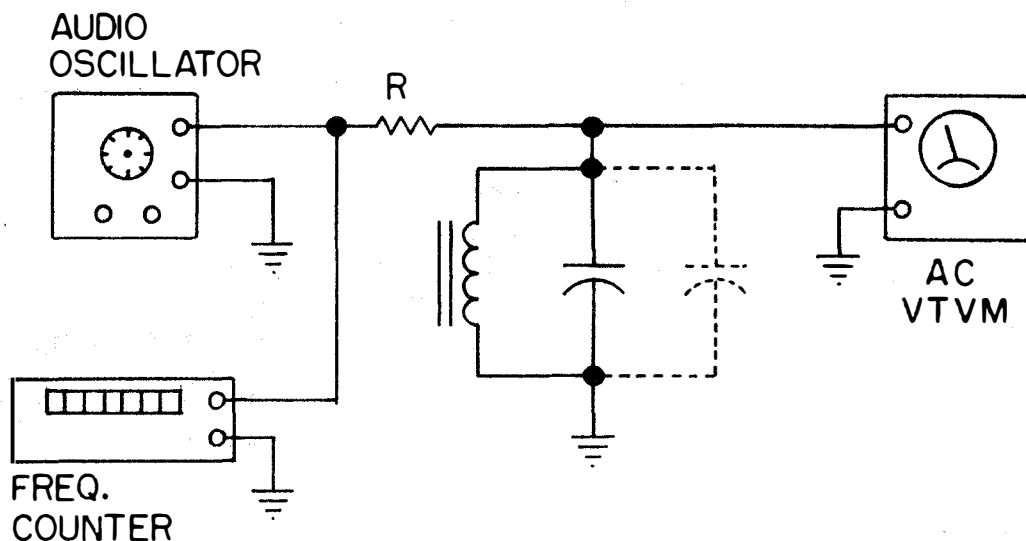

FIGURE 3-3

The general procedure is to tune the audio oscillator until a peak is obtained on the AC VTVM. When this peak is obtained, the frequency counter will indicate the resonant frequency of the filter circuit.

If the resonant frequency is too low, it can be raised by either decreasing the capacitance or carefully removing turns from the toroid.

NOTE - Capacitors typically used will be 10% or 20% tolerance and a significant change in the resonant frequency will be obtained by substituting other capacitors, if available, with the same marked value. It is recommended that you pick the capacitor which provides resonance closest to the resonant frequency on the low side; i.e., right on or just below the desired resonant frequency.

Additional tuning details are provided during the specific tuning procedures listed in the following paragraphs.

3.3 FILTER TUNING PROCEDURE

Careful attention should be paid to the tuning of the DT-600 Bandpass and Discriminator filter circuits, in particular the Discriminator, as these will greatly affect the performance of the unit. A frequency counter is highly desirable for this purpose as it will significantly simplify the task of proper filter alignment.

Note - Only mylar, polystyrene, metalized polycarbonate or mica capacitors (in increasing order of preference from a stability standpoint) are recommended for use in the filter circuits.

CAUTION - WHEN USING TOROIDS ON THE DT-600 BOARD, MAKE SURE TO PLACE A PIECE OF INSULATING MATERIAL BETWEEN THE TOROID AND THE FOIL UNDERNEATH.

3.3.1 Discriminator Filter Tuning (Toroidal Inductors)

a. Refer to Figure 3-4 and connect two toroids with their windings in series for 88 Mh.

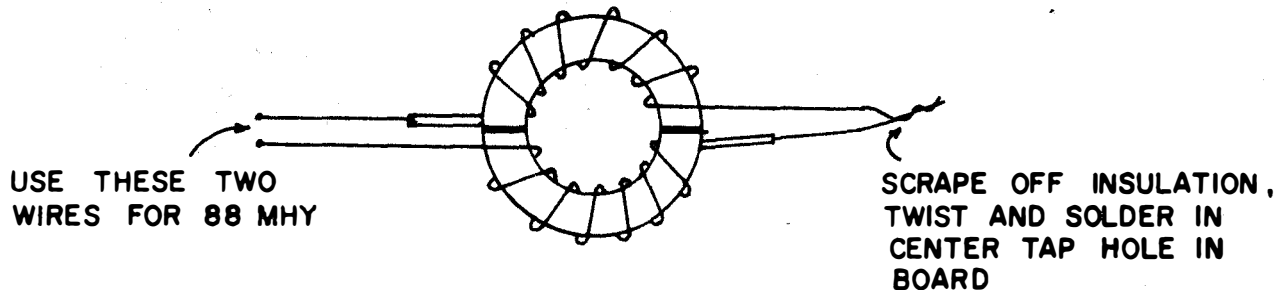

SERIES TOROID CONNECTION FOR 88 MHY

MARK Filter (L-4 and C-15)

FIGURE 3-4

b. Using the first of these toroids, connect as shown in Figure 3-3 with a .068 uf capacitor.

c. Tune this combination for 2135 Hz (10 Hz higher than the 2125 Hz MARK frequency to allow for circuit interaction when the filters are mounted on the board and for a small amount of capacitor aging).

Note - When removing turns from the Discriminator toroids, remove the same number of turns from each winding. One turn removed from both windings will raise the resonant frequency approximately 6 Hz.

CAUTION - TUNE IN SMALL STEPS, PARTICULARLY WHEN REMOVING TURNS.

d. Once tuned, refer to the component layout pictorial (Figure 3-1) and mount these components on the board.

SPACE Filter (L-5 and C-16)

e. Again refer to Figure 3-3 and connect the second toroid with a .056 uf capacitor for narrow shift or a .033 uf capacitor for wide shift.

f. Repeat steps c. and d. above, tuning this combination for 2305 Hz (narrow shift) or 2985 Hz (wide shift) as applicable.

3.3.2 Bandpass Filter Tuning (Toroidal Inductors)

a. Take the three remaining toroids and series connect them for 88 Mh as shown in Figure 3-4 for wide shift units or 22 Mh as shown in Figure 3-5 for narrow shift units.

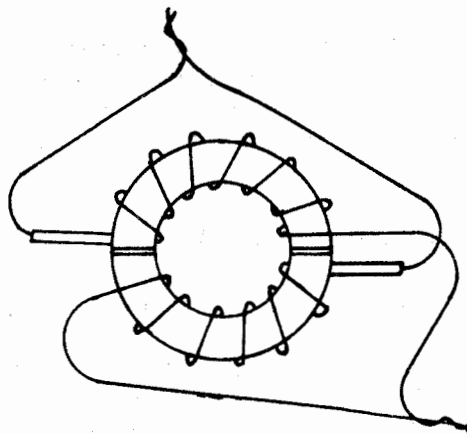

**SCRAPE OFF INSULATION,
TWIST AND SOLDER, AND
USE THESE CONNECTIONS
FOR 22 MHY.**

FIGURE 3-5

PARALLEL TOROID CONNECTION FOR 22 MHY.

Note - If the unit is being set up for wide shift, the bandpass filter is sufficiently broad that no tuning is required. Mount L-1 thru L-3 and C-1 thru C-8 on the circuit board and proceed to Section IV for checkout and alignment procedures.

For information, the wide shift bandpass filter stages resonate at approx. 2400 Hz (L-1, C-1, C-2, C-7), 2500 Hz (L-2, C-3, C-4, C-7, C-8), and 2400 Hz (L-3, C-5, C-6, C-8) respectively.

Narrow Shift Procedures:

b. Following the same procedures used in Section 3.3.1, tune L-1, C-1, C-2, and C-7 for 2195 Hz.

c. Except for C-7 which will be used in the next stage tuning, mount these components on the board.

d. Next, tune L-2, C-3, C-7 and C-8 for 2195 Hz. (C-4 is not used for narrow shift units). (Do not substitute values for C-7)

e. Except for C-8, mount these components on the board.

f. In like manner, tune L-3, C-5, C-6 and C-8 for 2195 Hz.
(Do not substitute values for C-8)

g. Mount these components on the board.

Note - All circuit board components shown on the component layout pictorial, Figure 3-1, should now be in place except for D-33 (and possibly R-1 which may be off board mounted).

This completes the toroidal filter tuning procedure. Turn to Section IV for check-out and alignment procedures.

SECTION IV

CHECKOUT AND ALIGNMENT

4.0 Once the printed circuit board has been completed, including filter tuning in Section III, you are ready for initial checkout and alignment. It is not necessary to have the ultimate enclosure completed to perform the steps outlined in this Section. However, the following items are necessary:

- a. 22-Pin Card Edge Connector
- b. +12 VDC Power Supply (50 ma. minimum)
- c. -12 VDC Power Supply (50 ma. minimum)
- d. One 1/4 or 1/2 Watt Resistor, 1K to 10K Ohms (resistance not critical)

WARNING - USE CAUTION DURING ALL TESTS NOT TO SHORT CARD EDGE CONNECTOR PINS TOGETHER OR LAY THE CIRCUIT BOARD ON A METALLIC SURFACE OR OBJECT AS CIRCUIT SHORTS COULD CAUSE DAMAGE TO CIRCUIT BOARD COMPONENTS.

4.1 Checkout Procedure

Referring to Figure 4-1, temporarily connect the power supplies, audio input, tuning meter, and the above mentioned resistor to the card edge connector. Plug the circuit board into the connector using care to match the card edge pin numbers to the socket pin numbers.

The following steps will ascertain whether or not the unit is basically functional before proceeding to the alignment procedure. If problems arise, refer to the Theory of Operation and Troubleshooting sections of this documentation package for assistance in isolating the problem.

These procedures assume that diodes D-32 and D-33 were left off the board during the construction phase.

- a. Set all 4 potentiometers to the center of their available tuning range.
- b. Connect an audio oscillator capable of the MARK and SPACE frequencies (2125/2295 Hz or 2125/2975 Hz) to the audio input, Pin 3.
- c. Carefully connect the positive lead of a DC voltmeter (12 VDC full scale minimum) to Pin 12 of the socket (Q2 collector). (Insure that the test resistor was connected to this same pin during the set-up phase.) Connect the negative lead of the voltmeter to ground.
- d. Turn on the power supplies. **TURN OFF IMMEDIATELY IN CASE OF SMOKE!!!**
- e. With no audio input, Pin 12 should read somewhat less than 1.0 volt (0.2v to 0.9v typical depending upon transistor type).
- f. Set the audio oscillator to SPACE (2295 Hz or 2975 Hz as appropriate). A few seconds after application of the audio the voltage on Pin 12 should read approximately +12 volts. (Absence of D-32 and D-33 disables the anti-space circuit allowing a steady SPACE to turn Q2 off).

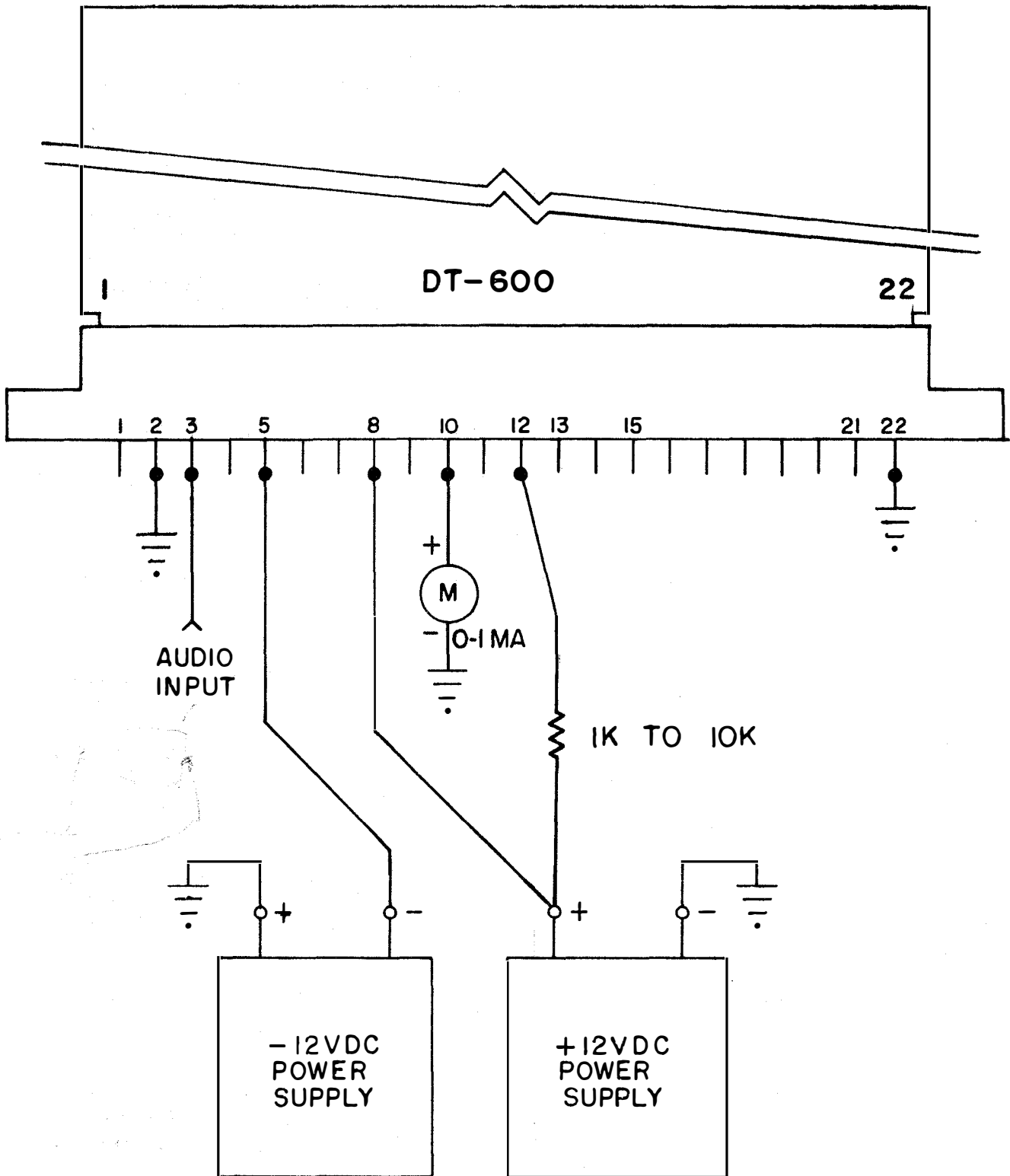

FIGURE 4-1

g. Carefully ground the Standby line, Pin 18. The voltage on Pin 12 should snap down to the MARK voltage (under 1 volt) when grounded and return to +12 VDC shortly after the ground is removed.

h. Vary the audio input frequency up and down slowly plus and minus 100 Hz. Once the frequency is moved off the SPACE frequency 30-50 Hz for a narrow shift unit or 60-80 Hz for a wide shift unit, the voltage at Pin 12 should again drop down to the MARK voltage indicating MARK HOLD. (Note - we have not yet set the autostart sensitivity pots so the above frequency ranges may not be very accurate at this point). The voltage will shift back up to the +12 volt SPACE reading a few seconds after the audio frequency is moved back within the autostart sensitivity range each time you tune toward the SPACE frequency.

i. Turn off the power supplies.

j. Move the resistor and voltmeter from Pin 12 of the socket to Pin 13.

k. Repeat steps d. through g. above. (All references to Pin 13 vice Pin 12)

l. Turn off the power supplies.

m. Move the resistor and voltmeter from Pin 13 of the socket to Pin 21.

n. Turn the audio oscillator OFF.

o. Turn on the power supplies and allow approximately 40 seconds for the autostart circuitry to stabilize. The voltage reading on Pin 21 should then be approximately +12 volts (analogous to autostart relay OFF).

p. Turn on the audio oscillator and set it to the MARK tone (2125 Hz). After 3-6 seconds of MARK the voltage on Pin 21 should drop to approximately 0.7 volts DC (indicating autostart relay ON).

q. Tune the audio oscillator away from the MARK (2125 Hz) frequency approx. 100 Hz (suggest setting 2000 Hz as a round number). After approximately 30 seconds the voltage on Pin 21 should rise to approximately +12 volts (indicating autostart relay OFF).

r. Turn the oscillator on, set the MARK frequency (2125 Hz) and allow the circuit to stabilize for approximately 10 seconds. The voltage on Pin 21 should read approximately +0.7 volts.

s. Set the oscillator to the SPACE frequency (2125 Hz or 2975 Hz). After approximately 30 seconds the voltage on Pin 21 should rise to approximately +12 VDC indicating autostart turn-off on steady SPACE. (This test demonstrates that the DT-600 autostart will not respond to steady SPACE signals and will turn off after 30 seconds if printing and the received signal goes to steady SPACE).

t. Turn off the power supplies.

u. Move the resistor and voltmeter from Pin 21 of the connector to Pin 15.

Note - Pin 15 is best referred to as the DATA FLAG as it directly follows the MARK HOLD circuit and indicates when MARK/SPACE data is available. Pin 3 corresponds to the collector of Q3 which is ON (TTL LOW) when no data is available and OFF (TTL HIGH) when data is available.

v. Turn the audio oscillator off.

w. Turn on the power supplies and allow approximately 10 seconds for the circuitry to stabilize.

x. The voltage on Pin 15 should be approximately +0.7 VDC, indicating NO DATA or NON-PRINT.

y. Turn on the audio oscillator and set the MARK frequency (2125 Hz). Approximately 3-6 seconds after setting MARK Pin 15 should rise to approximately +12 VDC. Tune the oscillator off frequency (away from the MARK and SPACE frequencies by at least 100 Hz) or turn the oscillator off. Pin 15 should drop almost immediately to approximately +0.7 VDC.

z. Turn off the power supplies.

aa. Mount diodes D-32 and D-33 on the circuit board and carefully solder in place.

bb. Move the resistor and voltmeter from Pin 15 of the connector back to Pin 12.

cc. Turn on the power supplies.

dd. Set the MARK frequency (2125 Hz) on the audio oscillator. Pin 15 should read under 1 VDC as in step e. above.

ee. Tune the oscillator to the SPACE frequency (2295 Hz or 2975 Hz). The voltage may flicker momentarily but should remain less than 1 VDC. This indicates that the ANTI-SPACE circuitry is working properly. (Notice in step f. above, before D-32 and D-33 were installed, that the voltage on Pin 12 climbed to +12 VDC).

ff. Turn off the power supplies. Disconnect the voltmeter and resistor from Pin 12. Turn off the audio oscillator.

This completes the initial checkout procedure.

Note - In a few cases it may be necessary to do a preliminary alignment before the unit will respond properly to all of the above checkout procedure.

4.3 Alignment Procedure

CAUTION - Use care in placing the voltmeter test lead on the various test points and pins in the following alignment procedure as it is easy to short pins and components together causing damage.

a. Turn on the power supplies.

b. Making sure that the audio oscillator is off or disconnected, ground the audio input lead (connects to Pin 3 as shown in Figure 4-1).

Note - a zero center DC voltmeter is best for the following alignment procedure but any DC voltmeter can be used as an alternate.

c. Set the positive meter lead to Test Point 1 (TP1)[Refer to the component layout. TP1 is near the card edge connector and R-51]. Ground the negative lead of the voltmeter.

d. It will not be possible to zero the meter reading as the Limiter (U-1) output being measured at TP1 will shift rapidly from positive to negative and vice versa. The idea is to set the DC Balance Pot, R-8, as close to the crossover point as possible.

e. Unground the audio input lead, turn on the audio oscillator, and set to the MARK frequency (2125 Hz).

f. Place the positive lead of the DC voltmeter on Test Point 2 (TP2)[located near U-5].

g. Carefully adjust the audio oscillator for a peak on the 0-1 ma. meter. (It may be necessary to adjust the meter potentiometer (R-76) for a convenient meter reading --- 1/2 to 2/3 scale is recommended at peak).

h. Note the meter reading. The idea here is to switch between the MARK and SPACE frequencies (peaking on the 0-1 ma. meter each time), and adjust the AC Balance Pot (R-17) for equal readings at TP2.

i. Using the positive lead of the DC voltmeter, carefully measure and record the voltage on Pin 2 of U-5.

j. Carefully tune the MARK frequency for a peak on the 0-1 ma. meter.

k. Adjust the Autostart Sensitivity Pot (R-50) so that the voltage on Pin 3 of U-5 is 1/2 volt (0.5 volt) LOWER than the voltage noted and recorded in step i. above. This procedure is equivalent but simpler than the frequency offset method described in the Ham Radio magazine article.

Note - If this recommended autostart sensitivity setting is not in accordance with your personal tastes after you have placed the DT-600 in operation, R-50 can be adjusted to some other setting at that time.

With the adjustment of the Tuning Meter Pot (R-76) for a convenient meter reading, this completes the alignment procedure.

1. Turn off the power supplies.

The DT-600 is now ready for mounting in a suitable enclosure.

DT-600 RTTY DEMODULATOR

PARTS LIST

SECTION 1 - LISTING BY PART NUMBER

THIS LIST FOR P.C. CARD ONLY

RESISTORS:

R-1 ✓	1.6K OHM, 1/4 WATT, 10%	(170 Shift)
	2.7K OHM, 1/4 WATT, 10%	(850 Shift)
R-2 ✓	620 OHM, 1/4 WATT, 10%	-----See Note 1
R-3 ✓	2.2K OHM, 1/4 WATT, 10%	(170 Shift)
	3.3K OHM, 1/4 WATT, 10%	(850 Shift)
R-4 ✓	4.7K OHM, 1/4 WATT, 10%	
R-5 ✓	470K OHM, 1/4 WATT, 10%	
R-6 ✓	1K OHM, 1/4 WATT, 10%	
R-7 ✓	10K OHM, 1/4 WATT, 10%	
R-8 ✓	10K OHM POTENTIOMETER, P.C. MOUNT	(PIHER Model PT-10V)
R-9 ✓	150K OHM, 1/4 WATT, 10%	
R-10 ✓	100 OHM, 1/4 WATT, 10%	
R-11 ✓	47 OHM, 1/4 WATT, 10%	
R-12 ✓	1.5K OHM, 1/4 WATT, 10%	
R-13 ✓	47 OHM, 1/4 WATT, 10%	
R-14 ✓	1 MEG OHM, 1/4 WATT, 10%	
R-15 ✓	1 MEG OHM, 1/4 WATT, 10%	
R-16 ✓	6.8K OHM, 1/4 WATT, 10%	(170 Shift)
	4.7K OHM, 1/4 WATT, 10%	(850 Shift)
R-17 ✓	5K OHM POTENTIOMETER, P.C. MOUNT	(PIHER Model PT-10V)
R-18 ✓	6.8K OHM, 1/4 WATT, 10%	(170 & 850 Shift)
R-19 ✓	100K OHM, 1/4 WATT, 10%	(170 Shift)
	33K OHM, 1/4 WATT, 10%	(850 Shift)
R-20 ✓	100K OHM, 1/4 WATT, 10%	
R-21 ✓	100K OHM, 1/4 WATT, 10%	
R-22 ✓	100K OHM, 1/4 WATT, 10%	
R-23 ✓	270K OHM, 1/4 WATT, 10%	(170 Shift)
	180K OHM, 1/4 WATT, 10%	(850 Shift)
R-24 ✓	10K OHM, 1/4 WATT, 10%	
R-25 ✓	33K OHM, 1/4 WATT, 10%	
R-26 ✓	10K OHM, 1/4 WATT, 10%	
R-27 ✓	220 OHM, 1/4 WATT, 10%	
R-28 ✓	22K OHM, 1/4 WATT, 10%	
R-29 ✓	22K OHM, 1/4 WATT, 10%	
R-30 ✓	100K OHM, 1/4 WATT, 10%	
R-31 ✓	220K OHM, 1/4 WATT, 10%	
R-32 ✓	220K OHM, 1/4 WATT, 10%	
R-33 ✓	10K OHM, 1/4 WATT, 10%	
R-34 ✓	33K OHM, 1/4 WATT, 10%	
R-35 ✓	2.2K OHM, 1/4 WATT, 10%	

R-43 ✓	10K OHM, 1/4 WATT, 10%
R-44 ✓	4.7K OHM, 1/4 WATT, 10%
R-45 ✓	2.2K OHM, 1/4 WATT, 10%
R-46 ✓	10K OHM, 1/4 WATT, 10%
R-47 ✓	68K OHM, 1/4 WATT, 10%
R-48 ✓	68K OHM, 1/4 WATT, 10%
R-49 ✓	39K OHM, 1/4 WATT, 10%
R-50 ✓	5K OHM POTENTIOMETER, P.C. MOUNT (PIHER Model PT-10V)
R-51 ✓	10K OHM, 1/4 WATT, 10%
R-52 ✓	33K OHM, 1/4 WATT, 10%
-R-53 ✓	68K OHM, 1/4 WATT, 10%
-R-54 ✓	75K OHM, 1/4 WATT, 10%
-R-55 ✓	120K OHM, 1/4 WATT, 10%
R-56 ✓	10K OHM, 1/4 WATT, 10%
R-57 ✓	2.2K OHM, 1/4 WATT, 10%
R-58 ✓	33K OHM, 1/4 WATT, 10%
R-59 ✓	10K OHM, 1/4 WATT, 10%
R-60 ✓	2.2K OHM, 1/4 WATT, 10%
R-61 ✓	1 MEG OHM, 1/4 WATT, 10%
R-62 ✓	10K OHM, 1/4 WATT, 10%
R-63 ✓	2.2K OHM, 1/4 WATT, 10%
R-64 ✓	2.2K OHM, 1/4 WATT, 10%
R-65 ✓	33K OHM, 1/4 WATT, 10%
R-66 ✓	10K OHM, 1/4 WATT, 10%
R-67 ✓	2.7K OHM, 1/4 WATT, 10%
R-68 ✓	56K OHM, 1/4 WATT, 10%
R-69 ✓	47K OHM, 1/4 WATT, 10%
R-70 ✓	330 OHM, 1/4 WATT, 10%
R-71 ✓	33K OHM, 1/4 WATT, 10%
R-72 ✓	10K OHM, 1/4 WATT, 10%
R-75 ✓	5.6K OHM, 1/4 WATT, 10%
R-76 ✓	10K OHM POTENTIOMETER, P.C. MOUNT (PIHER Model PT-10V)

CAPACITORS:

C-1 .15 UFD 25-100V MYLAR OR POLYSTYRENE (170 Shift)
~~.015 UFD 25-100V MYLAR OR POLYSTYRENE (850 Shift)~~
 C-2 .056 UFD 25-100V MYLAR OR POLYSTYRENE (170 Shift)
~~.018 UFD 25-100V MYLAR OR POLYSTYRENE (850 Shift)~~
 C-3 .18 UFD 25-100V MYLAR OR POLYSTYRENE (170 Shift)
~~.015 UFD 25-100V MYLAR OR POLYSTYRENE (850 Shift)~~
 C-4 .01 UFD 25-100V MYLAR OR POLYSTYRENE (850 Shift)
 C-5 .15 UFD 25-100V MYLAR OR POLYSTYRENE (170 Shift)
~~.015 UFD 25-100V MYLAR OR POLYSTYRENE (850 Shift)~~
 C-6 .056 UFD 25-100V MYLAR OR POLYSTYRENE (170 Shift)
~~.018 UFD 25-100V MYLAR OR POLYSTYRENE (850 Shift)~~
 C-7 .022 UFD 25-100V MYLAR OR POLYSTYRENE (170 Shift)
~~.015 UFD 25-100V MYLAR OR POLYSTYRENE (850 Shift)~~
 C-8 .022 UFD 25-100V MYLAR OR POLYSTYRENE (170 Shift)
~~.015 UFD 25-100V MYLAR OR POLYSTYRENE (850 Shift)~~
 C-9 .1 UFD 25V DISC CERAMIC
 C-10 .1 UFD 25V DISC CERAMIC
 C-11 3 PF DISC CERAMIC (3.3 PF Acceptable)
 C-12 .1 UFD 25V DISC CERAMIC
 C-13 47 PF DISC CERAMIC
 C-14 .047 UFD DISC CERAMIC
 C-15 .068 UFD 25-100V MYLAR OR POLYSTYRENE (170 & 850 Shift)
 C-16 .056 UFD 25-100V MYLAR OR POLYSTYRENE (170 Shift)
~~.033 UFD 25-100V MYLAR OR POLYSTYRENE (850 Shift)~~
 C-17 .012 UFD 25-100V MYLAR OR POLYSTYRENE (170 Shift)
~~.018 UFD 25-100V MYLAR OR POLYSTYRENE (850 Shift)~~
 C-18 .68 UFD 25-100V MYLAR OR POLYSTYRENE
 C-19 .18 UFD 25-100V MYLAR OR POLYSTYRENE
 C-20 10 UFD 15V TANTALUM
 C-21 10 UFD 15V TANTALUM
 C-24 ~~18~~ ²² UFD 15V TANTALUM -----See Note 2
 C-25 4.7 UFD 15V TANTALUM
 C-26 ~~18~~ ²² UFD 15V TANTALUM -----See Note 2
 C-27 10 UFD 15V TANTALUM
 C-36 200 PF DISC CERAMIC

DIODES:

D-1 thru D-4 Any small silicon diode, 50 PIV or higher (e.g., 1N914)
 D-5 thru D-12 1N270 germanium diode ----- See Note 3
 D-13 thru D-16 Any small silicon diode, 50 PIV or higher (e.g., 1N914)
 D-21 thru D-30 Any small silicon diode, 50 PIV or higher (e.g., 1N914)
 D-32 thru D-34 Any small silicon diode, 50 PIV or higher (e.g., 1N914)

Charles L. Houghton - OTY
 6395 Bodgen Lake
 SD CA 92119

REV 1

OPERATIONAL AMPLIFIERS:

U-1 709 (TO-99 Package)
U-2 thru U-8 741 ✓ (Mini-Dip Package)

TRANSISTORS:

Q-1 ✓ 2N3904, 2N2222, or equiv. silicon NPN
Q-2 2N5656, MJE-340, or equiv. H.V. silicon NPN
Q-3 ✓ 2N3904, 2N2222, or equiv. silicon NPN
Q-4 ✓ 2N3904, 2N2222, or equiv. silicon NPN
Q-5 ✓ 2N3904, 2N2222, or equiv. silicon NPN
Q-6 ✓ 2N3904, 2N2222, or equiv. silicon NPN
Q-7 ✓ 2N3904, 2N2222, or equiv. silicon NPN

Q-10 ✓ 2N3904, 2N2222, or equiv. silicon NPN

MISCELLANEOUS:

L-1 thru L-5 88 MHY C.T. Toroids or Pot Cores

Note 1 - If the communications receiver has a very high audio output capability (e.g., 2 watts or over) and there is danger of the audio gain control being turned up, recommend R-2 be mounted off the P.C. board (across the speaker terminals or demodulator audio input terminals) and be rated at 2 watts.

Note 2 - Recommend use of 18 UFD vice 22 UFD for C-24 and C-26 as these values provide a little nicer time constants for autostart turn on and turn off.

Note 3 - If silicon diodes are used in place of the germanium diodes specified above, there will be no noticeable difference in performance under other than laboratory conditions.

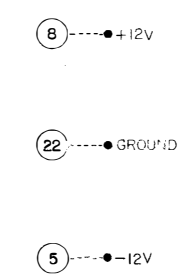
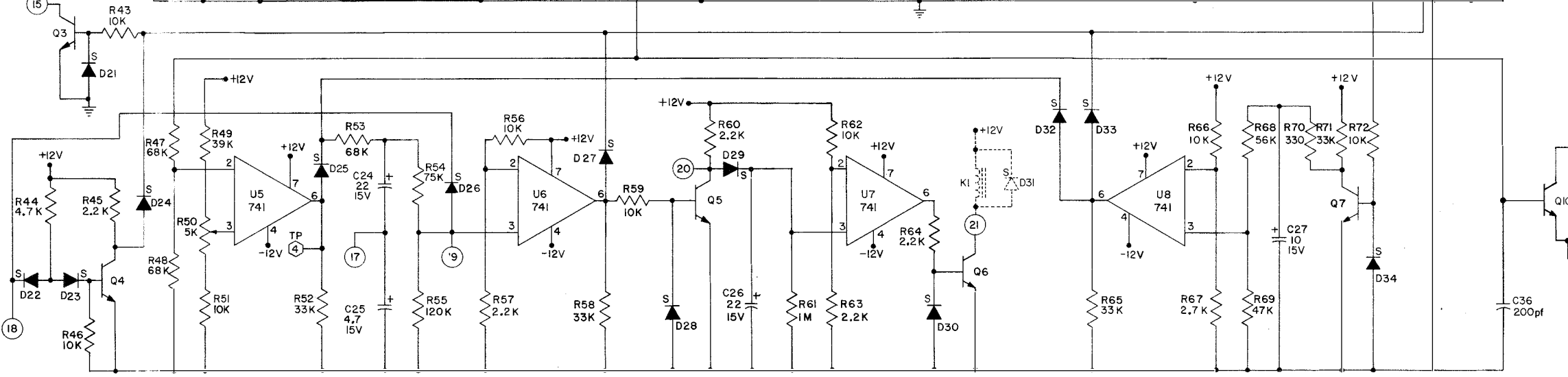
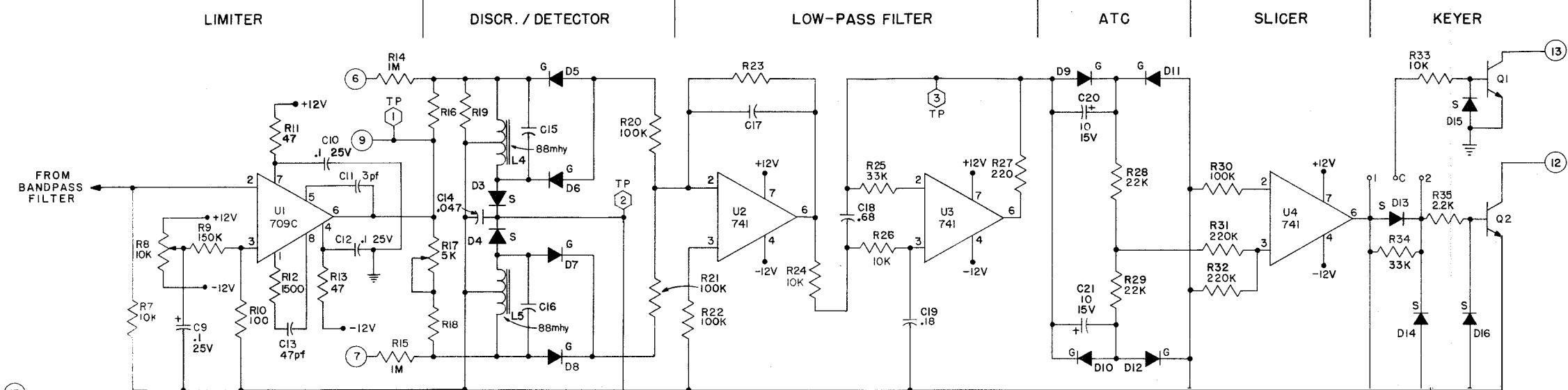

STANDBY | AUTOSTART | MOTOR CONTROL | ANTI-SPACE | TUNING METER

NOTES

1. DOTTED PORTION OF DRAWING INDICATES CIRCUIT COMPONENTS NOT MOUNTED ON CIRCUIT BOARD.
2. DIODES MARKED "G" ARE GERMANIUM IN270
3. DIODES MARKED "S" ARE SILICON 50PIV UNLESS NOTED
4. RESISTORS 1/4 WATT UNLESS NOTED
5. CAPACITORS IN MFD. UNLESS NOTED
6. TRANSISTORS/OP AMPS:
U-1 709C
U-2 THRU 8 741
Q2 - 2N5656, MJE340 OR EQUIV.
Q1, Q3 THRU Q7, Q10 - 2N3904, 2N2222 OR EQUIV.

DISCRIMINATOR VALUES

	2125/2295	2125/2975
R16	6.8K	4.7K
R18	6.8K	6.8K
R19	100K	33K
R23	270K	180K
C15	.068	.068
C16	.056	.033
C17	.012	.018

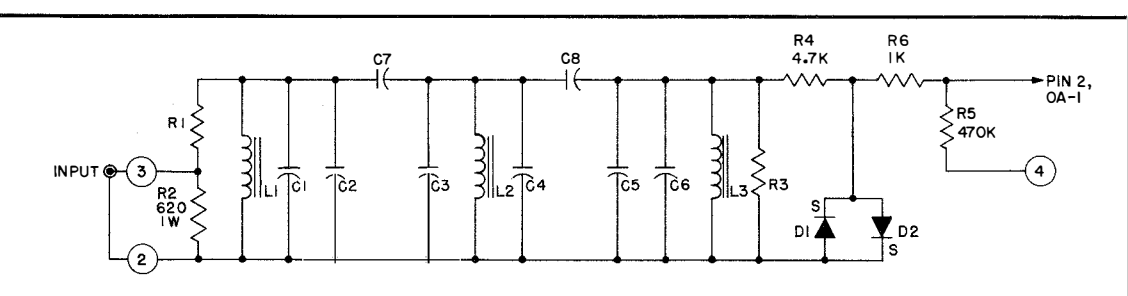

MARK	SPACE	SHIFT	C1	C2	C3	C4	C5	C6	C7	C8	L1,2,3	R1	R3	SEC 1	SEC 2	SEC 3
2125	2295	170	.15	.056	.18	—	.15	.056	.022	.022	22MH	1.6K	2.2K	2195	2195	2195
2125	2975	850	.015	.018	.015	.01	.015	.018	.015	.015	88MH	2.7K	3.3K	2400	2300	2400
1575	2425	850									88MH					

TUNING FREQS

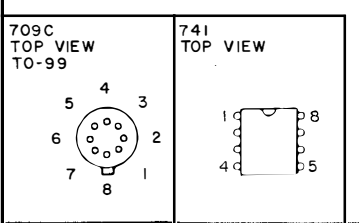

DT-600 TELETYPE DEMODULATOR

DATA TECHNOLOGY ASSOCIATES, INC.
P.O. BOX 431912
MIAMI, FLORIDA 33143