

# FIELD ENGINEERING MANUAL

**HANDBOOK OF INSTRUCTIONS  
FOR  
ADAPTER, RADIO TELETYPE  
UG-(XA-4) /U**

IB-39620



**ENGINEERING GROUP  
FIELD OPERATIONS SECTION**

**RCA SERVICE COMPANY, INC.**

**CAMDEN, N. J.**

A Radio Corporation of America Subsidiary  
**GOVERNMENT SERVICE DIVISION**

THIS DOCUMENT CONTAINS INFORMATION AFFECTING THE NATIONAL DEFENSE OF THE UNITED STATES WITHIN THE MEANING OF THE ESPIONAGE LAWS, TITLE 18, U.S.C., SECTION 793 AND 794. THE TRANSMISSION OR REVELATION OF ITS CONTENTS IN ANY MANNER TO AN UNAUTHORIZED PERSON IS PROHIBITED BY LAW.

# BE PREPARED WITH FIRST AID



KNOW THE NEWLY APPROVED METHOD OF

## ARTIFICIAL RESPIRATION



(HOLGER NIELSON METHOD)

### Artificial Respiration GENERAL CONSIDERATIONS

- 1. Start Immediately, Seconds Count**  
Do not move victim unless absolutely necessary to remove from danger. Do not wait or look for help or stop to loosen clothing, warm the victim or apply stimulants.
- 2. Check Mouth for Obstructions**  
If necessary, remove foreign objects — Pull tongue forward.
- 3. Loosen Clothing — Keep Warm**  
Take care of these items after victim is breathing by himself or when help is available. Do not interrupt the rhythm.
- 4. Remain in Position**  
After victim revives, be ready to resume respiration if necessary.
- 5. Call A Doctor**  
Have someone summon medical aid.
- 6. Don't Give Up**  
Continue without interruption until victim is breathing without help or is certainly dead.

### LAY VICTIM IN PRONE POSITION

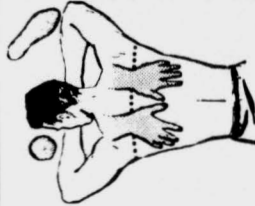

Elbows bent, one hand on the other. Head on hands, face to one side. Kneel at victim's head on either knee.



### 1 PLACE HANDS

Fingers spread, thumbs touching, heels of hands below line connecting armpits.



### 2 APPLY PRESSURE

Rock forward slowly until arms are vertical. Keep elbows straight.



### 3 RELEASE PRESSURE

Rock back slowly. Grasp victim's arms just above elbows. Continue backward.



### 4 LIFT ARMS

Raise arms until tension is felt, then lower victim's arms, completing cycle.

## REPEAT CYCLE 12 TIMES PER MINUTE

THIS MATERIAL HAS BEEN PRODUCED BY THE GOVERNMENT SERVICE DIVISION, ENGINEERING GROUP FOR THE INFORMATION, GUIDANCE AND USE OF RCA SERVICE COMPANY FIELD ENGINEERS SERVING WITH THE MILITARY. THE MATERIAL HEREIN NEITHER SUPERSEDES NOR TAKES PRECEDENCE OVER ANY OFFICIAL MILITARY ORDER, LETTER, MANUAL OR PUBLICATION. INITIAL DISTRIBUTION HAS BEEN LIMITED TO RCA SERVICE COMPANY EMPLOYEES.

RADIO CORPORATION OF AMERICA  
RCA VICTOR DIVISION  
Front and Cooper Streets  
Camden, New Jersey, U.S.A.

IB-39620

HANDBOOK OF INSTRUCTIONS  
FOR  
ADAPTER, RADIO TELETYPE  
UG-(XA-4)/U

Modification of  
Frequency Shift Converter CV-57/URR

Supplement to Instruction Book for  
Frequency Shift Converter CV-57/URR

15 December 1953  
Contract: AF33(600)-23134  
dated 1-5-53

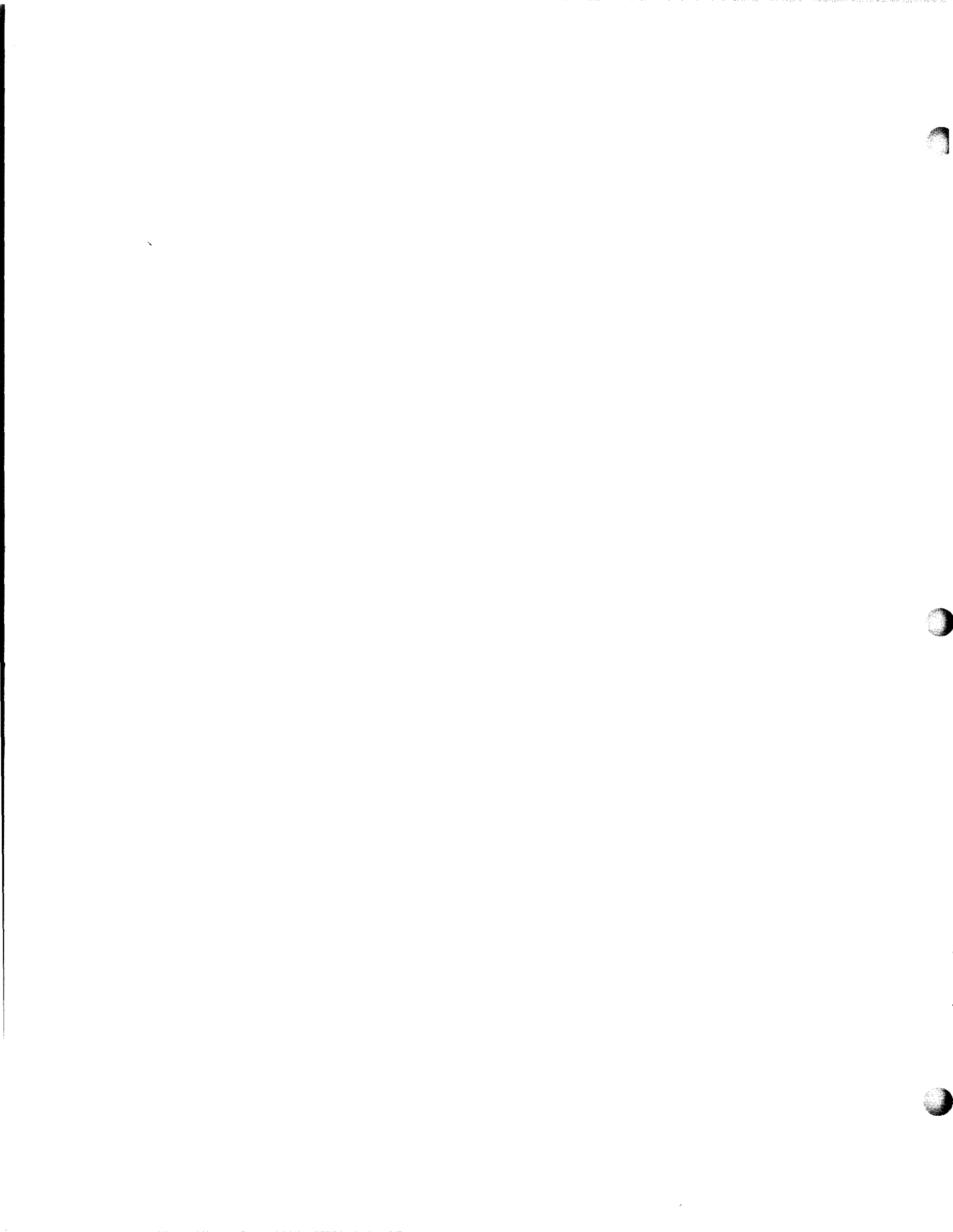

## TABLE OF CONTENTS

PARAGRAPH	SUBJECT	Total number of pages <sup>49</sup> PAGE
SECTION A. GENERAL DESCRIPTION		
1.	SCOPE .....	6
2.	EQUIPMENT SUPPLIED .....	6
3.	EQUIPMENT REQUIRED BUT NOT SUPPLIED .....	7
4.	GENERAL DESCRIPTION .....	8
	a. Purpose and use .....	8
	b. Housing .....	8
	c. Adapter, Radio Teletype UG-(XA-4)/U Construction .....	8
	d. Power Supply .....	9
	e. Input Unit .....	9
	f. I-F Unit .....	9
	g. Keyer Unit .....	9
	h. Tuning Monitor Unit .....	9
	i. Exciter-Filter-Relay Unit .....	9
5.	POWER CONSUMPTION .....	10
6.	INTERCHANGEABILITY .....	10
SECTION B. INSTALLATION AND ADJUSTMENT		
7.	UNPACKING .....	11
8.	PRE-INSTALLATION INSPECTION AND TESTS .....	11
	a. Inspection .....	11
	b. Tests .....	11
9.	INSTALLATION .....	14
	a. Location .....	14
	b. Mounting .....	14
	c. Connecting Cables .....	14
SECTION C. OPERATION		
10.	INTRODUCTION .....	15
11.	CAPABILITIES AND LIMITATIONS .....	16
12.	OPERATING CONTROLS .....	16
13.	OPERATING ADJUSTMENTS .....	16
14.	OPERATING PROCEDURE .....	17
	a. Starting Procedure .....	17
	b. Tuning to Another Frequency .....	17
	c. Transmitting Procedure .....	18
	d. Stopping the Adapter, Radio-Teletype UG-(XA-4)/U .....	18

TABLE OF CONTENTS (Continued)

PARAGRAPH	SUBJECT	PAGE
SECTION D. THEORY OF OPERATION		
15.	INTRODUCTION .....	18
16.	ADAPTER, RADIO TELETYPE UG-(XA-4)/U .....	18
	a. General .....	18
	b. Reception .....	18
	c. Transmission .....	19
	d. Chassis Arrangement .....	19
17.	ADAPTER CHASSIS ASSEMBLY .....	19
18.	EXCITER-FILTER-RELAY UNIT .....	20
	a. General .....	20
	b. Exciter Circuits .....	20
	c. Filter, Relay and Power Circuits .....	20
19.	INPUT UNIT .....	21
20.	I-F UNIT .....	21
21.	KEYER UNIT .....	21
22.	TUNING MONITOR UNIT .....	24
23.	POWER SUPPLY UNIT .....	24
SECTION E. MAINTENANCE		
24.	GENERAL .....	24
25.	ROUTINE MAINTENANCE .....	24
	a. Fuses .....	24
	b. Figures 5-3 and 7-9 .....	24
	c. System Sensitivity .....	25
	d. % Mark Check .....	25
	e. Mod Bal Check and Gate Balance Adjustment .....	25
	f. Teletypewriter Loop Current Adjustment .....	25
	g. Adjustment after Replacement of D-C Amplifier, V903 ...	25
	h. Lubrication .....	25
26.	CORRECTIVE MAINTENANCE .....	25
27.	LOCALIZING TROUBLE, ADAPTER, RADIO TELETYPE UG-(XA-4)/U .....	25
28.	UNIT TROUBLE SHOOTING AND REPAIR .....	26
	a. Equipment Required .....	26
	b. Exciter-Filter-Relay Unit .....	26
	c. Power Supply .....	29
	d. Tuning Monitor .....	29
	e. Input Unit .....	29
	f. I-F Unit .....	29
	g. Keyer Unit .....	29

TABLE OF CONTENTS (Continued)

PARAGRAPH	SUBJECT	PAGE
SECTION F. SUPPLEMENTARY INFORMATION		
29.	TUBE COMPLEMENT .....	32
30.	PHOTOGRAPHS .....	32

SECTION G. PARTS LIST

SECTION H. DRAWINGS

LIST OF ILLUSTRATIONS

FIGURE	TITLE	PAGE
1.	Exciter-Filter-Relay Unit, Top View .....	33
2.	Exciter-Filter-Relay Unit, Bottom View .....	33
3.	Block Diagram, Adapter, Radio Teletype UG-(XA-4)/U .....	42
4.	Schematic Diagram, Adapter, Radio Teletype UG-(XA-4)/U .....	43
5.	Schematic Diagram, Exciter-Filter-Relay Unit .....	44
6.	Installation Cabling Diagram .....	45



# FIRST AID

## WARNING!

Operation of electronic equipment involves the use of high voltages which are dangerous to life. Operating personnel must at all times observe all safety regulations. Do not change tubes or make adjustments inside the equipment with voltage supply on. Under certain conditions dangerous potentials may exist in circuits with power controls in the off position due to charges retained by capacitors, etc. To avoid casualties, always discharge and ground circuits prior to touching them.

## ABOUT FIRST AID

Personnel engaged in the installation, operation and maintenance of this equipment or similar equipment are urged to become familiar with the following rules both in theory and in the practical application thereof. It is the duty of every radioman to be prepared to give adequate First Aid and thereby prevent avoidable loss of life.

## PRONE-PRESSURE METHOD OF RESUSCITATION

1. PROTECT YOURSELF with dry insulating material.
2. BREAK THE CIRCUIT by opening the power switch or by pulling the victim free of the live conductor.

**DON'T TOUCH VICTIM WITH YOUR BARE HANDS UNTIL THE CIRCUIT IS BROKEN.**

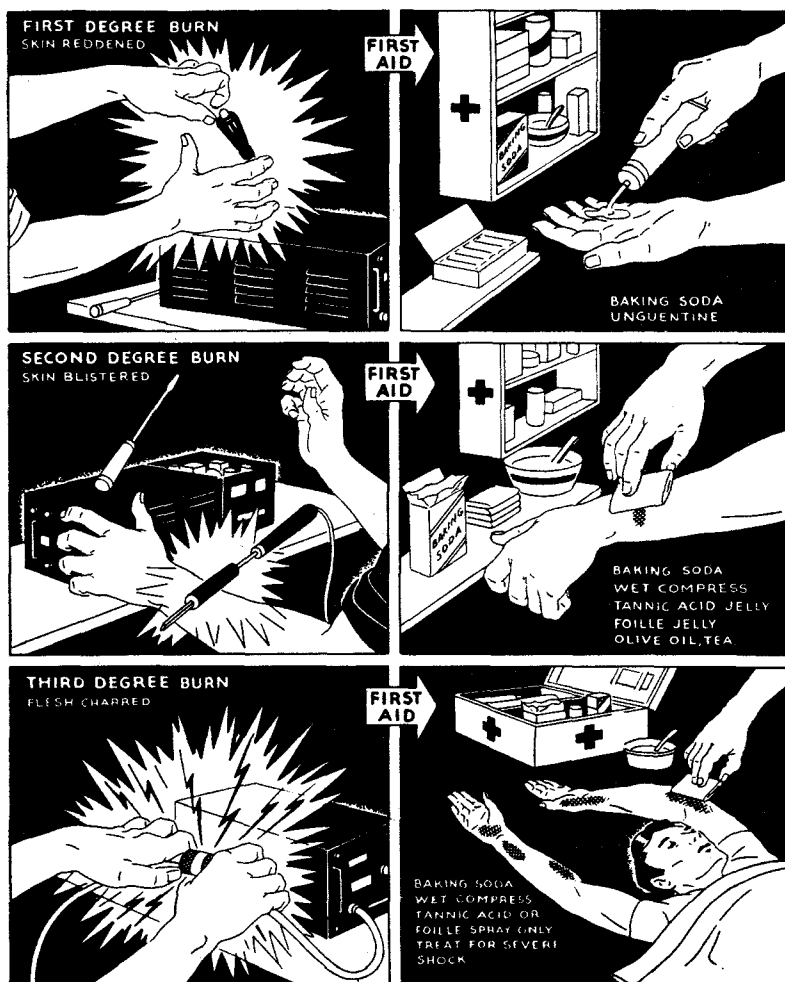

(A)



(B)

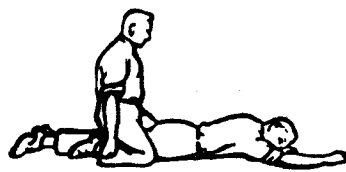

(C)

3. LAY PATIENT ON STOMACH, one arm extended, the other arm bent at elbow. Turn face outward resting on hand or forearm.
4. REMOVE FALSE TEETH, TOBACCO OR GUM from patient's mouth.
5. KNEEL STRADDLING PATIENTS THIGHS. See (A).
6. PLACE PALMS OF YOUR HANDS ON PATIENT'S BACK with little fingers just touching the lowest ribs.
7. WITH ARMS STRAIGHT, SWING FORWARD gradually bringing the weight of your body to bear upon the patient. See (B).
8. SWING BACKWARD IMMEDIATELY to relieve the pressure. See (C).
9. AFTER TWO SECONDS, SWING FORWARD AGAIN. Repeat twelve to fifteen times per minute.
10. WHILE ARTIFICIAL RESPIRATION IS CONTINUED, HAVE SOMEONE ELSE:
  - (a) Loosen patient's clothing.
  - (b) Send for doctor.
  - (c) Keep patient warm.
11. IF PATIENT STOPS BREATHING, CONTINUE ARTIFICIAL RESPIRATION. Four hours or more may be required.
12. DO NOT GIVE LIQUIDS UNTIL PATIENT IS CONSCIOUS.



SECTION A

GENERAL DESCRIPTION

1. SCOPE.

This book amends NAVSHIPS 91355, the Instruction Book for Frequency Shift Converter Comparator Groups AN/URA-6, AN/URA-7 and Frequency Shift Converter CV-57/URR to show changes made to the Frequency Shift Converter CV-57/URR for aircraft teletype transmission and reception use with Radio Set AN/ARC-21 and Auxiliary Radio Receiver R-224/ARR-36. The nomenclature of the converted units is Adapter, Radio Teletype UG-(XA-4)/U. This book gives the necessary information and corrections to make references to the Frequency Shift Converter CV-57/URR apply to the Adapter, Radio Teletype UG-(XA-4)/U.

2. EQUIPMENT SUPPLIED.

To Table 1-1 Equipment Supplied, on page 1-10 of NAVSHIPS 91355 indicate the addition of a table as follows:

TABLE A-1. EQUIPMENT SUPPLIED

ADAPTER, RADIO TELETYPE UG-(XA-4)/U

QUAN- TITY PER EQUIP- MENT	NAME OF UNIT	TYPE NUMBER	OVERALL DIMENSIONS (INCHES)			VOL- UME CU. FT.
			HEIGHT	WIDTH	DEPTH	
1	Adapter, Radio Teletype including tubes, external connecting plugs and jumper cable	UG-(XA-4)/U	5 1/8	17 5/16	14 13/16	1
2	Instruction Books (RCA IB-38482), one with supplement IB-39620	NAVSHIPS 91355				
1	Suitable container containing:					
	(A) 1 Bracket Assembly, Shock Mount Right Hand					
	(B) 1 Bracket Assembly, Shock Mount Left Hand					
	(C) Not supplied					
	(D) Not supplied					
	(E) 1 Channel					
	(F) 4 Shock Mounts					

TABLE A-1. EQUIPMENT SUPPLIED (Continued)

QUAN- TITY PER EQUIP- MENT	NAME OF UNIT	TYPE NUMBER	OVERALL DIMENSIONS (INCHES)			VOL- UME CU. FT.
			HEIGHT	WIDTH	DEPTH	
	(G) 1 Suitable container con- taining:					
	(1) 26 screws #8-32 x 3/8 pan h head					
	(2) 16 screws 1/4-20 x 1/2 hex head					
	(3) 26 lockwashers #8					
	(4) 16 lockwashers 1/4					
	(5) 16 nuts 1/4-20					
	(6) 8 washers #8					
1	Set of Spare Parts for Adapter, Radio Teletype UG-(XA-4)/U					

3. EQUIPMENT REQUIRED BUT NOT SUPPLIED.

To Table 1-2, Equipment and Publications Required But Not Supplied, on page 1-11 of NAVSHIPS 91355, indicate the addition of a table as follows:

TABLE A-2. EQUIPMENT AND PUBLICATIONS REQUIRED BUT NOT SUPPLIED

ADAPTER, RADIO TELETYPE UG-(XA-4)/U

QUAN- TITY PER EQUIP- MENT	NAME OF UNIT	TYPE NUMBER	REQUIRED USE	REQUIRED CHARACTERISTICS
1	Radio Set	AN/ARC-21	Transmission and recep- tion of signals	Using Power Supply PP-298/ ARC-21X
1	Auxiliary Radio Receiver	R-224/ARR- 36	Reception of signals	
1	Teletypewriter	TT-4A/ TG(XC-5)	Transcribe signals	

TABLE A-2. EQUIPMENT AND PUBLICATIONS REQUIRED BUT NOT SUPPLIED  
(Continued)

QUAN- TITY PER EQUIP- MENT	NAME OF UNIT	TYPE NUMBER	REQUIRED USE	REQUIRED CHARACTERISTICS
1	Power Source	--	Supply power	28 volts dc
1	Power Source	--	Supply power	115 volts ac 400 cycles
	Cabling (as indicated by the Interconnection Connection Cabling Diagram		Supply inter- connections	
2	Circuit breakers (5-ampere)	MS-25005-5	Protect line, teletypewriter and Adapter, Radio Teletype UG-(XA-4)/U	

4. GENERAL DESCRIPTION.

a. PURPOSE AND USE. Adapter, Radio Teletype UG-(XA-4)/U enables the use of Radio Set AN/ARC-21 and Auxiliary Radio Receiver R-224/ARR-36 for reception and transmission of frequency shift keying teletype signals. Once installed and functioning, the equipment can be controlled at the adaptor-teletypewriter position after the operating frequency and frequency shift keying is selected at the radio set control. Changing from reception to transmission is accomplished by the transmit-receive switch on the teletypewriter.

b. HOUSING. Adapter, Radio Teletype UG-(XA-4)/U is housed in its own metal case which can be mounted on a flat surface. A pair of shock mount brackets are supplied for surface mounting. In NAVSHIPS 91355, figure 1-1a shows the rack mounting, while the gussets are shown in figure 1-2. Figure 1-1b of the present book shows the Adapter, Radio Teletype UG-(XA-4)/U with shock mounts, although the actual shock mounts supplied are of the aircraft type. Extending from the rear of the case is the housing for the Exciter-Filter-Relay Chassis, taking place of the Filter Unit described in NAVSHIPS 91355.

c. ADAPTER, RADIO TELETYPE UG-(XA-4)/U CONSTRUCTION. Sliding drawer construction is used with several plug-in chassis on which are mounted the necessary components. The drawer acts mainly as a support and interconnection base. Control knobs on the front panel need not be removed when chassis are replaced, since the chassis control shafts are connected to the knob shafts by quick-setting couplings. Turning the right-hand handle clockwise and the left-hand handle counterclockwise unlocks the chassis so it can be pulled out of the case on the side rails. The handles are unlocked by pressing the button near the top of the handle. Pulling the chassis out of the case disconnects power,

control and signal circuits. These circuits can be restored while the chassis is pulled forward by using the jumper cable, W1402, supplied. The drawer can be tipped to various angles and locked at 45 or 90 degrees from horizontal for accessibility during servicing.

d. POWER SUPPLY. A plug-in power supply, operating from a 115-volt, 400-cycle source is supplied as one of the plug-in chassis. This power supply provides the operating power for heaters, plate power, bias voltage and oscilloscope power.

e. INPUT UNIT. The input unit takes the 300-kilocycle output signal of the Radio Set AN/ARC-21 receiver section, and converts it to an output frequency of 40 kilocycles for the i-f Unit. An automatic frequency control tube, V102, getting control voltage from the discriminator in the i-f Unit keeps the conversion oscillator on frequency. This unit is similar to the one supplied with the Frequency Shift Converter CV-57/URR, except for component changes for 300-kilocycle input instead of 395 to 470-kilocycle input.

f. I-F UNIT. The i-f Unit amplifies and limits the 40-kilocycle signal, after which the signal is fed through a discriminator to give positive and negative pulses corresponding to the received frequency shifts. Further information, as given in NAVSHIPS 91355 in regard to this unit, is correct since no changes were made in it to apply it to Adapter, Radio Teletype UG-(XA-4)/U.

g. KEYER UNIT. The Keyer Unit amplifies and filters the output of the discriminator, after which the signal drives trigger tubes to give the proper waveform to the pulses that are to drive the teletypewriter. These pulses then drive the output tubes whose plates are connected directly in the teletypewriter circuit. A d-c restorer establishes an axis around which the positive and negative signal voltages are symmetrical. Since the subject equipment is a conversion from the Frequency Shift Converter CV-57/URR, which had been designed for reception only, several changes are made in the Keyer Unit, to reduce power consumption so the new Exciter-Filter-Relay Unit can be operated without overloading the Power Supply Unit. The output tubes V607 and V608 are type 6AK6, and the tone modulator and tone oscillator tubes are removed although some of the components remain. The heater of tube V602A is also disconnected. A new relay, K601, permits switching of the keyer tube control grids from the trigger #2 output to the teletypewriter contacts in the transmit position for monitoring of printing. This relay is energized by the teletypewriter transmit-receive switch.

h. TUNING MONITOR UNIT. The Tuning Monitor Unit gives a visual check on receiver tuning of center frequency. Operation and description are the same as for the Frequency Shift Converter CV-57/URR. The units used in the Adapter, Radio Teletype UG-(XA-4)/U have changes in lead dress only to reduce ripple from the 400-cycle power source.

i. EXCITER-FILTER-RELAY UNIT. The Exciter-Filter-Relay Unit replaces the triangular filter mounted on the rear of the case. This chassis provides for transmission of teletype signals and filtering of the various external connections.

Crystal-controlled space and mark oscillators are connected to their respective gate tubes which, in turn, are controlled by the teletypewriter output signals.

The combined outputs of the gate tubes drives a five-to-one divider and locked-in oscillator, the output of which is supplied to the radio transmitter by a coaxial line through a cathode follower tube. An on-off relay, a transmit-receive relay and an auxiliary receiver relay are included for remote switching operations. The auxiliary relay selects either Radio Set AN/ARC-21 or Auxiliary Radio Receiver R-224/ARR-36 for reception of signals. A selenium rectifier power supply supplies the power for the teletypewriter receiving loop circuit. A cooling fan and group of filters complete the electrical items in the Exciter-Filter-Relay Unit. All external connections are made by plugs and jacks while a single jack provides all the internal connections.

#### 5. POWER CONSUMPTION.

During reception the power consumption is approximately 3 amperes at the rated line voltage of 115 volts, 400 cycles. During transmission the power consumption is approximately 3 amperes at the rated line voltage of 115 volts, 400 cycles.

#### 6. INTERCHANGEABILITY.

The Adapter, Radio Teletype UG-(XA-4)/U is specifically designed for use with Radio Set AN/ARC-21 and Auxiliary Radio Receiver R-224/ARR-36 and is not interchangeable with any other equipment or system. The Power Supply Unit, i-f Unit and Tuning Monitor are interchangeable with like units in the Frequency Shift Converter CV-57/URR or Frequency Shift Comparator Groups AN/URA-6 and AN/URA-7.

## SECTION B

### INSTALLATION AND ADJUSTMENT

#### 7. UNPACKING.

For unpacking information see paragraph 1 on page 3-1 of NAVSHIPS 91355.

#### 8. PRE-INSTALLATION INSPECTION AND TESTS.

a. Inspection. The Adapter, Radio Teletype UG-(XA-4)/U has been carefully inspected, bench tested and adjusted at the factory for optimum results. After inspection for damage during transportation it can be installed in the aircraft and the initial adjustments made although a bench test is desirable before installation.

Inspect the equipment for damage that may have occurred during shipment. Slide the drawer out of the case by pushing the button at the top of each handle while turning the right hand handle clockwise and the left hand handle counterclockwise as far as they will go. Pull the drawer out of the case as far as it will go.

#### CAUTION

Do not slide the drawer out unless the case is firmly anchored to the support otherwise the case will be over-balanced which may result in damage to the equipment if it overturns.

Check that the tubes and components are undamaged. Make sure the mounting screws for the various chassis are tight. To inspect the components on the under side of the drawer, press the bell shaped button near the bottom of the handles and lift the drawer to vertical position. To examine the Exciter-Filter-Relay Chasais, remove the cover at the rear of the case. Check that the tubes and components are undamaged.

b. Tests. Where facilities are available the adapter should be given an operational test before installation in the aircraft to prevent grounding the aircraft unnecessarily due to troubles in the Adapter, Radio Teletype UG-(XA-4)/U. The additional items required for a bench test and initial adjustments are as follows:

- An operating Radio Set AN/ARC-21 with suitable antenna
- Power Supply Source, 27.5 volts dc and 115 volts ac 400 cycles
- Teletypewriter TT-4A/TG(XC-5)
- Cabling for Radio Set AN/ARC-21 and Adapter, Radio Teletype UG-(XA-4)/U
- 0 to 100-milliampere milliammeter (may be incorporated in teletypewriter)
- Test oscilloscope
- Test receiver (tunable to point in range of 2 to 23 mc and having bfo)

Signal generator (unmodulated tunable to same frequency as test receiver)

R-f vacuum tube voltmeter (40 to 500-kc)

- (1) Close all circuit breakers in the supply lines.
- (2) Set the CW BROAD - CW SHARP - VOICE - FSK switch of Radio Set AN/ARC-21 to FSK.
- (3) Turn CONTROL switch of Radio Set AN/ARC-21 to ON.
- (4) Set CHANNEL to channel on which teletype signals can be received.
- (5) Set teletypewriter transmit-receive switch to receive.
- (6) Set POWER switch on Adapter, Radio Teletype UG-(XA-4)/U to ON.
- (7) Allow the equipment to warm up for two minutes.
- (8) If the line voltage is above or below 115 volts at the adapter input, turn POWER to OFF, remove the power supply unit and adjust tap on power transformer T801 by changing leads on terminal 2, 3 or 4. These terminals are for 105, 115 and 125 volts respectively.
- (9) Turn POWER to ON. The indicator light on the front panel should glow in about 10 seconds indicating the B+ voltage is on.
- (10) Set the TUNE-OPERATE switch to TUNE.
- (11) Tuning Monitor Adjustment. After the power has been on for one minute adjust the tuning monitor as follows:
  - (a) Using a screwdriver, adjust the INTENSITY control for a reasonably bright trace and the FOCUS control for sharpest trace. Too bright a trace will result in short tube life and focusing difficulties. These controls are located under oil cap type covers to the right above and below the tuning monitor tube.
  - (b) Turn POWER switch to OFF, slide the drawer out of the case and interconnect the drawer and Exciter-Filter using the jumper cable furnished as shown in figure 3-15 of NAVSHIPS 91355.
  - (c) Turn POWER switch to ON and allow one minute for warmup. Set the VERT. GAIN control fully counterclockwise and press the CAL IN button.
  - (d) Loosen the lock nut and adjust resistor R705, located just below the V CENT potentiometer R702, until the oscilloscope sweep line coincides with the center line engraved on the front window. Tighten the lock nut.
  - (e) Release the CAL IN button.
  - (f) Adjust V CENT, on panel, with a screwdriver until oscilloscope line coincides with the engraved center line.
  - (g) Readjust FOCUS with screwdriver for best average focus with CAL IN button depressed and released.
- (12) Adjustment of Teletypewriter Loop Current. Proceed as follows:
  - (a) Set SPEED switch to LOW. HIGH is used only for high speed multiplex or speeds greater than 60 words per minute.
  - (b) Plug a 0-100 milliammeter into the TTYP jack on the front panel. The meter should be connected to a standard phone plug with the meter "minus" connected to the plug tip and "plus" connected to the plug sleeve. If the teletypewriter has a built-in milliammeter in the loop circuit, use this meter. With no keying signal (steady mark) adjust the teletypewriter loop current, by adjusting resistor R1125 in the Exciter-Filter to a value of 30 milliamperes. When the teletypewriter is keying, the current indication on the meter will drop.
- (13) TUNING Adjustment. Proceed as follows:
  - (a) Use an unmodulated signal generator set to exact receiving frequency of Radio Set AN/ARC-21 for initial tuning of the adapter. Pick up



the transmitter output, on the chosen channel, by a receiver with a beat frequency oscillator. Tune the receiver to zero beat with the beat frequency oscillator turned on. Turn transmitter off and adjust signal generator to zero beat with test receiver. Turn off test receiver and connect signal generator to Radio Set AN/ARC-21 receiver input.

(b) Connect an r-f (40-kilocycle) vacuum tube voltmeter to terminal 1 on terminal board E302 and ground. This terminal is at the right hand side of the rear center in the I-F Unit. Set the vacuum tube voltmeter to the 10-volt range. Set the front panel TUNING control at center of travel (0).

(c) On the Input Unit adjust the core of transformer T101, and then the top and bottom cores of transformers T102 and T103 for maximum indication on the r-f voltmeter. Reduce signal generator output during tuning to keep meter reading on scale.

(d) Disconnect signal generator and connect an antenna to the receiver input of the Radio Set AN/ARC-21. Select a channel to receive teletype signals. With the VERT GAIN control, adjust the separation of the two horizontal lines on the tuning monitor tube to a convenient distance apart.

(e) Adjust TUNING on adapter to center the lines on the oscilloscope tube (see figure 3-16 of NAVSHIPS 91355).

(f) Set TUNE-OPERATE switch to OPERATE; teletypewriter may start printing.

(14) Calibration Adjustment. Proceed as follows:

(a) Push CAL IN button and adjust THRESHOLD control to produce a pattern on the Tuning Monitor tube which matches the top and bottom lines engraved on the Tuning Monitor window (see figure 3-17 of NAVSHIPS 91355).

(b) Release CAL IN button. Teletypewriter should be printing; if it does not, change the position of the NORM-REV switch.

(c) Turn the SPEED switch to ADJ and press the CAL IN button. The Tuning Monitor tube pattern should fit between the top and bottom engraved lines on the window within 1/16 inch. This is a sensitivity check of the Tuning Monitor tube V702 and amplifier V601B. If the pattern does not match the engraved lines, check the circuits as given in section 6 of NAVSHIPS 91355.

(d) Return the SPEED switch to LOW position and proceed with the % MARK adjustment.

(15) % MARK Adjustment. Proceed as follows:

(a) Connect an external oscilloscope across a 20-ohm resistor. Connect the resistor to terminals of a phone plug and insert the phone plug in the TYP jack located under the spring cover at the bottom left of the panel.

(b) Set speed switch to ADJ. Set test oscilloscope sweep for approximately 600 cycles with the sync. off.

(c) Adjust sweep of test oscilloscope so the peak of one cycle is centered in the trough of another cycle.

(d) Adjust the % MARK control to give peaks and troughs of equal width (see figure 3-19 NAVSHIPS 91355).

(e) Remove test oscilloscope and return SPEED switch to former position (HIGH or LOW). Teletypewriter should be printing normally. If operation is still unsatisfactory repeat procedure or check for trouble as given in section 7 of NAVSHIPS 91355.

(16) Exciter-Filter-Relay Unit Adjustment. No adjustments are required for the Exciter-Filter except for the adjustment of the teletypewriter loop current which has been given previously in this section. This unit is best tested by the transmission of teletypewriter signals that are received correctly by another installation.

## 9. INSTALLATION.

a. Location. The Adapter, Radio Teletype UG-(XA-4)/U should be located on a flat surface convenient to the associated teletypewriter. Allow front and rear clearance for convenience of operation and accessibility for maintenance. Allow side clearance for access to the interconnecting plugs and jacks. Figure 3-21, on pages 3-23 and 3-24 of NAVSHIPS 91355 can be used as an installation guide except for size and shape of shockmounts. The mounting screw arrangements will be the same except the hole sizes will be smaller. Mount the equipment so the front panel is even with the front edge of the support to allow the drawer to be tilted when withdrawn from the case.

b. Mounting. Assemble the shockmounts to the brackets first. Proceed as follows:

(1) Assemble two shockmounts, (F) of table A-1, to each of the bracket assemblies (A) and (B), table A-1, using 6-24 screws, lockwashers and nuts supplied. Put the lockwashers under the nuts.

(2) Attach the assemblies from step (1) to the channel (E) of table A-1, using eight No. 8-32 x 3/8 screws. Put flatwashers and lockwashers under the screws with the lockwashers next to the screw heads.

(3) Turn the case upside down and put the shock mount assembly in place.

(4) Fasten the shockmount assembly to the case with nine No. 8-32 x 3/8 screws and lockwashers on each side of the cabinet.

(5) Drill the four mounting holes for 1/4-20 bolts (not supplied). Two of the holes have 1 1/4-inch centers for the front shockmounts and the other two holes are 7 and 5/8 inches directly to the rear of the front bolt hole centers.

(6) Turn the equipment over to rest on the shock mounts and bolt to the support. The equipment is now ready to be connected into the system by cables.

c. Connecting Cables. Since the Adapter, Radio Teletype UG-(XA-4)/U is designed specifically for use with Radio Set AN/ARC-21 and Auxiliary Radio Receiver R-224/ARR-36, cabling information will be given as required in addition to the normal cabling of these associated equipments.

(1) General. Connectors required for connecting the adapter into the aircraft cabling are supplied as part of the equipment. Cable length should be kept to a minimum with wire sizes of the power leads large enough to prevent the voltage at the adapter terminals dropping below the rated value under load. Control and signal wires are not critical in length and size but should be kept short as practical. The three remaining cables are coaxial connecting the 100- and 300-kilocycle signals to the transmitting and receiving equipments.

(2) Open Wire Cable. This cable makes all interconnections except those for high frequency currents. The AN3106-20-1S connector required is supplied with the equipment. Use the Installation Cabling Diagram figure 6 as

a guide for fabricating the open wire cable. Run the leads directly to the indicated terminals using number 22 wire as a minimum wire size. The power wires must be large enough to deliver rated line voltage to the equipment under maximum load conditions (5 amperes each for the 28-volt d-c and 115-volt a-c lines).

Mount the circuit breakers either within the reach of the teletypewriter operator or on the aircraft circuit breaker panel according to the aircraft plan. Grounds indicated in the Installation C bling Diagram should be made at the location of the equipment as shown in the diagram. For instance leads 701A, 703A and 711A should be grounded to the aircraft frame at the Adapter, Radio Teletype UG-(XA-4)/U location. A solid ground connection at the mounting of all units must be made in addition to the specified plug safety grounds.

(3) Coaxial Cables. Cables 433A and 434A are required for transmission and reception using the Radio Set AN/ARC-21 and cable 714A is required for reception using the Auxiliary Radio Receiver R-224/AFR-36. These cables are made up of RG-58/U cable with UG-88/U connectors at either end. These cables should be run as directly as possible with enough slack at each end to permit the unit to vibrate freely on its shockmount and permit easy disconnection of the cable.

## SECTION C

### OPERATION

#### 10. INTRODUCTION.

The Adapter, Radio Teletype UG-(XA-4)/U, covered by this instruction book, is only part of the complete teletypewriter radio receiving and transmitting system. Other equipment required to complete the system are: a teletypewriter for coding and decoding the messages to be transmitted and received, a Radio Set AN/ARC-21 for transmission and reception of the frequency shift signals and a power source for supplying the required power to various pieces of equipment making up the overall installation.

A frequency shift keyed signal, centered about the 300-kilocycle intermediate frequency of the Radio Set AN/ARC-21 receiver section, is one of the input signals for the Adapter, Radio Teletype UG-(XA-4)/U. This signal shifts to higher and lower frequencies corresponding to the characters transmitted. The adapter translates these frequency shifts into off-on, keyed, d-c square-wave pulses to key the receiving teletypewriter loop circuit.

The teletypewriter output pulses for transmission, the other input signal to the adapter, key gate tubes, one each for the mark and space signals. These gate tubes connect the output of crystal oscillators, one a + nominal frequency and the other a - nominal frequency, to the Radio Set AN/ARC-21 transmitter exciter to shift the transmitter output frequency in accordance to the mark

and space pulses. A locked-in 5-to-1 divider-oscillator, whose frequency is shifted by the mark and space oscillators, operates nominally at 100 kilocycles output as the center frequency signal. This signal is applied to the transmitter exciter as shifted by the crystal oscillators. A cathode follower couples the adapter output to the transmitter exciter by a coaxial cable.

#### 11. CAPABILITIES AND LIMITATIONS.

For reception the equipment provides the best possible teletype signals when not subjected to interference and the irregularities common to radio transmission. It will, however, give accurate conversion up to the point where the noise level is approximately equal to or greater than the signal. The output signal level of the receiver must be high enough to keep the input to the adapter limiter stage well above saturation level.

Little attention of the operator is required during operation after the equipment has warmed up (warm-up time is about 10 minutes). The Tuning Monitor gives continuous, visible monitoring of the discriminator output. The neon ON indicator, operating from the +200-volt supply, gives a continuous indication of the B power supply for the tubes.

#### 12. OPERATING CONTROLS:

All operating controls are located on the front panel with all but the essential operating controls located under a center cover or behind oil-cup-type hole covers. This feature helps prevent break in service due to the operator accidentally manipulating the wrong knob. All but two controls, primarily of a maintenance nature, are accessible from the front panel.

#### 13. OPERATING ADJUSTMENTS.

The operating adjustments and their functions are listed in table C-1.

TABLE C-1. OPERATING ADJUSTMENTS

Control	Function
TUNING	Tunes the adapter to the intermediate (300 kc) frequency of Radio Set AN/ARC-21 receiver.
AFC ON-OFF	Disables automatic frequency Control circuits of adapter when in the OFF position.
TUNE-OPERATE	Prevents teletypewriter being keyed when in the TUNE position.
THRESHOLD	Adjusts discriminator output signal to proper level for Keyer Unit input.
NARROW-WIDE	Selects input signal and switches the discriminator for narrow or wide frequency shift.
TONE FREQUENCY	Not used in this equipment.
TONE LEVEL	Not used in this equipment.
SPEED	Selects proper filter for standard or high-speed teletypewriter. Applies a standard voltage for adjustments in the ADJ position.

TABLE C-1. OPERATING ADJUSTMENTS (Continued)

Control	Function
NORM-REV	Reverses polarity of teletype signals.
POWER OFF-ON	Turns power to Power Supply Unit on or off. Does not de-energize crystal oven, power line filters or teletypewriter loop circuit.
VERT GAIN	Adjusts height of pattern on Tuning Monitor tube.
CAL IN	Indicates Keyer Unit input voltage when depressed. Tuning Monitor tube is indicator.

14. OPERATING PROCEDURE.

a. Starting Procedure. With the Radio Set AN/ARC-21 operating on FSK and receiving frequency shift signals start the Adapter, Radio Teletype UG-(XA-4)/U as follows:

- (1) Turn POWER switch of the adapter to ON. The POWER switch may be kept in the ON position since the adapter is turned ON and OFF as a function of Radio Set AN/ARC-21. Allow sufficient time for all equipment to warm up.
- (2) Set teletypewriter transmit-receiver switch to receive.
- (3) Set the TUNE-OPERATE switch to TUNE and the AFC ON-OFF switch to ON. The automatic frequency control is off when the TUNE-OPERATE switch is in the TUNE position.
- (4) Adjust the TUNING of the adapter carefully to vertically center the horizontal lines on the Tuning Monitor tube. See figure 3-16 of NAVSHIPS 91355.
- (5) Set the TUNE-OPERATE switch to OPERATE.
- (6) Press the CAL IN button and adjust the THRESHOLD control to produce a Tuning Monitor pattern which matches the top and bottom lines engraved on the Tuning Monitor window. See figure 3-17 of NAVSHIPS 91355.
- (7) Release the CAL IN button.
- (8) The teletypewriter should be printing. If it is not printing change position of NORM-REV switch. If teletypewriter still does not operate refer to the maintenance procedures to locate the trouble.
- (9) Observe the Tuning Monitor indication occasionally and readjust receiver tuning as necessary to maintain proper operation until the equipment has thoroughly stabilized.

b. Tuning To Another Frequency. Proceed as follows:

- (1) Set the TUNE-OPERATE switch to TUNE and the AFC control to ON.
- (2) Change the Radio Set AN/ARC-21 to the new channel. Adjust the TUNING control to center the horizontal lines on the Tuning Monitor tube. See figure 3-16 of NAVSHIPS 91355.
- (3) Set the TUNE-OPERATE switch to OPERATE.
- (4) Push CAL IN button and adjust THRESHOLD control to produce Tuning Monitor tube pattern to match the parallel lines engraved on the Tuning Monitor window. See figure 3-17 of NAVSHIPS 91355.
- (5) Release the CAL IN button.
- (6) Teletypewriter should now be printing; if it is not, change the position of the NORM-REV switch.

c. Transmitting Procedure. To transmit teletype signals proceed as follows:

(1) Set Radio Set AN/ARC-21 to proper channel.

(2) After initial tune-up time has elapsed change teletypewriter transmit-receive switch to transmit and allow transmitter tune-up time for Radio Set AN/ARC-21.

(3) Send signals using teletypewriter keyboard. The teletypewriter printer should type the message being sent.

d. Stopping the Adapter, Radio Teletype UG-(XA-4)/U. To stop the adapter, switch the Radio Set AN/ARC-21 to another type of operation or off. The POWER switch on the adapter should be in the ON position except during maintenance periods.

## SECTION D

### THEORY OF OPERATION

#### 15. INTRODUCTION

This section covers the theory of operation of the Adapter, Radio Teletype UG-(XA-4)/U. The adapter uses frequency shift keying signals from the Radio Set AN/ARC-21 or Auxiliary Radio Receiver R-224/ARR-36 for reception. For transmission, the teletypewriter output signals are converted into frequency shift signals for the transmitter of the Radio Set AN/ARC-21.

A frequency shift signal is one whose normal frequency is shifted to another frequency for a period of time corresponding to the coding of the information being transmitted. The adapter changes the received frequency shift signals into d-c pulses of sufficient amplitude to operate a teletypewriter or other automatic recording device. Frequency shifts of from 10 to 1000 cycles, at the discriminator, can be handled by the subject equipment. For transmission the mark signal is generated at 501.0625 kilocycles and the space signal is 498.9375 kilocycles both of which are divided five times to give approximate 100-kilocycle signals for the Radio Set AN/ARC-21 transmitter.

#### 16. ADAPTER, RADIO TELETYPE UG-(XA-4)/U.

a. General. The Adapter, Radio Teletype UG-(XA-4)/U unit (see figure 3, the block diagram) is converted from CV-57/UJR units described in the NAVSHIPS instruction manual 91355. Two main conversions are made, one the change of input frequency of from 395 to 470 kilocycles to a lower center frequency of 300 kilocycles. The other conversion is the inclusion of facilities for converting the teletypewriter output signals into frequency shift pulses with a nominal frequency of 100 kilocycles for radio transmission by the Radio Set AN/ARC-21 equipment.

b. Reception. The receiver signal is filtered, converted to a 40-kilocycle frequency, amplified, clipped by the limiter and fed through a discriminator. The discriminator output is amplified, filtered, amplified again and then triggers two Eccles-Jordan flip-flop stages in cascade to key the teletypewriter keyer tubes.

c. Transmission. The teletypewriter keyboard (output) signals key mark and space gate tubes connected to the mark and space crystal oscillators. The output frequency of the gate tubes is divided by five by a locked-in oscillator and the resulting frequency-shifted 100-kilocycle frequency is applied to the Radio Set AN/ARC-21 for transmission. The teletypewriter keyboard output is also applied to the keyer tubes so the teletypewriter prints the characters transmitted by the keyboard.

d. Chassis Arrangement. The equipment is enclosed in a shock mounted metal case for shielding and mechanical protection. Unitized construction is used with all but the Exciter-Filter-Relay Unit being mounted in a drawer which slides out of the case for servicing. The individual units are plugged into jacks and held in place by screws except for the Exciter-Filter-Relay Unit which forms the back of the case and extends to the rear. All external connections are made through this unit. The following list gives data on the names and schematic diagrams for the different units:

Unit Name	Symbol Series	Schematic Diagram	
		NAVSHIPS	Figure Number This Publication
Adapter Chassis	1400	91355	---
Exciter-Filter-Relay Unit	1100	---	---
Input Unit	100	*7-38	---
I-F Unit	300	7-36	---
Keyer Unit	600	---	---
Tuning Monitor Unit	700	7-22	---
Power Supply Unit	800	7-28	---

\*Correct except for some values

#### 17. ADAPTER CHASSIS ASSEMBLY.

Refer to the system schematic diagrams, figures 4 and 5. All connections to the Exciter-Filter-Relay Unit and to the units on the adapter chassis are made by plugs and jacks. Plug P1401, mounted on the rear of the adapter chassis, engages with jack J1101 on the Exciter-Filter-Relay Unit when the adapter chassis is properly seated in the case. This permits external cable connections, which are made to the Exciter-Filter-Relay Unit, to be carried into the chassis assembly cable and distributed to jacks J1403 to J1407 inclusive. These jacks, in turn, engage the proper sub-assembly plugs when these units are assembled in the adapter chassis. Other electrical items of the chassis are the B+ "on" indicator and socket 1/X1401, the POWER OFF-ON switch S1401, the TTYP and PHONES jacks J1401 and J1402, and the B+ dropping resistor R1402.

The B+ "on" indicator is a neon lamp connected between ground and the 200-volt supply, in series with a limiting resistor R807 located in the power supply. The neon lamp glows to indicate that a voltage of 200 volts is present in the Power Supply Unit.

The POWER OFF-ON switch makes or breaks both legs of the a-c line into the power transformer primary. The TTYP jack, J1401, is connected in series with the external teletypewriter loop circuit and is used to meter the loop current and otherwise monitor the loop circuit. The PHONES jack, J1402, is not used in this equipment.

#### 18. EXCITER-FILTER-RELAY UNIT.

a. General. Refer to the schematic diagram, figure 5 and the block diagram, figure 3. The exciter portion provides the necessary components for converting the teletypewriter output pulses into the 100-kilocycle, frequency shifted signals, for the Radio Set AN/ARC-21 transmitter. The filter portion has control relays, filters for all the leads to jack J1102, a power supply for the teletype loop circuit and the jacks for all external and internal connections.

b. Exciter Circuits. The "mark" and "space" frequencies are generated by crystal oscillators using a double triode JAN 12AU7 tube V1101. The individual oscillators have the crystals connected from control grid, pins 2 and 7, to ground with a powered-iron core tuned transformer in the plate, pins 1 and 6, circuit. The transformers also couple the crystal oscillators into the gate tubes V1102 and V1103. The crystals are mounted in a temperature controlled oven to maintain the mark crystal frequency at 501.0625 kilocycles and the space crystal frequency at 498.9375 kilocycles.

The mark and space gate tubes, V1102 and V1103 are biased at the control grid, pin 1, so the mark gate tube will only respond to mark pulses and the space gate tube will only respond to space pulses from the teletypewriter. The mark and space frequencies are applied to the number 3 grid, pin 7, of the respective tubes. The plates, pin 5 on each of the gate tubes, are connected in parallel and have a common tunable output impedance.

The gate output is coupled into a locked-in oscillator using pins 6, 7, 8 of tube V1104. This oscillator is a five times divider used to reduce the frequency modulation produced when the gate tubes are keyed. The degree of frequency modulation is reduced by the divider ratio and remains a constant factor which is not increased by subsequent multiplication of frequency. An adjustable tuned impedance permits alignment of this stage. The locked-in oscillator output, centered around 100 kilocycles, is coupled into the other triode section of V1104 which operates as a cathode follower. This matches the output impedance to the coaxial line, coupling the adapter to the Radio Set AN/ARC-21 through jack J1105.

c. Filter, Relay and Power Circuits. All leads, except the ground leads making external connections through the main cable jack, J1102, are filtered. The filters are varied in design to provide efficient filtering with minimum voltage drop in the associated circuits. No filtering is necessary for the three coaxial interconnecting cables.

Three relays provide the control functions of the equipment from external locations. Relay K1101 turns on the 28-volt d-c and 115-volt a-c power to the equipment when energized by the Auxiliary Radio Receiver R-224/ARR-36 or the



Radio Set AN/ARC-21. This relay is energized through contacts of the input selection relay K1102. Relay K1101 is energized whenever the CW BROAD - CW SHARP - VOICE - FSK switch on the radio set control of either the Auxiliary Radio Receiver R-224/ARR-36 or the Radio Set AN/ARC-21 is in the FSK position and the CONTROL is ON.

Relay K1102 is energized when the Auxiliary Radio Receiver R-224/ARR-36 is operated on FSK. This relay energizes relay K1101 and in addition switches the adapter receiver output coaxial cable from the Radio Set AN/ARC-21 jack, J1104, to the Auxiliary Radio Receiver R-224/ARR-36 jack J1103. Relay K1103 is the transmit-receive relay energized for transmission through the teletypewriter transmit-receive switch. When energized this relay applies B+ voltage to the exciter tubes and energizes relay K601 in the Keyer Unit. Relay K601 applies the teletypewriter output pulses to the keyer tubes so the teletypewriter printer will monitor the transmission. During transmission the B+ voltage is removed from the Trigger II, V604. In the receive position, relay K601 is de-energized for signal reception, the B+ voltage is applied to the Trigger II tube, V604, and the B+ voltage is removed from the exciter tubes.

An a-c motor, B1101, drives a fan for cooling the equipment. A source of direct current for the teletypewriter loop circuit is provided using two germanium rectifiers in series to give suitable inverse resistance under high temperature conditions. A capacitor, C1118 provides the necessary filtering and resistor R1125 provides the voltage adjustment for the teletypewriter loop circuit. Rectifier CR1103 provides bias voltage.

#### 19. INPUT UNIT.

See paragraph 5 on page 2-2 of NAVSHIPS 91355 for the theory of operation. See the schematic diagram, figure 4 of this book for changes in values of components to give the 300-kilocycle input frequency required by the associated receiving equipments.

#### 20. I-F UNIT.

See paragraph 6 on page 2-3 of NAVSHIPS 91355 for the theory of operation. To show interconnections use the schematic diagram, figure 4 of this book.

#### 21. KEYER UNIT.

See the schematic diagram figure 4 of this book. During reception periods the Keyer Unit receives the d-c pulses from the discriminator, amplifies and filters them to energize the Eccles-Jordan flip-flop circuit. This circuit in turn, keys a power output stage to key the teletypewriter loop circuit. During transmission the Trigger II section of the Eccles-Jordan flip-flop circuit has the B+ voltage removed and the teletypewriter output pulses are fed into the keyer tubes, V607 and V608, to operate the teletypewriter printer

for monitoring the transmission. The tubes used in the Keyer Unit are as follows:

Schematic Symbol	Tube Type	Circuit Function
V601A		A-F Amplifier I
V601B	JAN12AU7	A-F Amplifier II
V602A		Not Used
	JAN12AU7	
V602B		Trigger Driver
V603A, B	JAN12AU7	Trigger I
V604A, B	JAN12AU7	Trigger II
V605		Not Used
V606	JAN6AL5	D-C Restorer
V607	JAN6AK6	Teletypewriter Loop Keyer
V608	JAN6AK6	Teletypewriter Loop Keyer

The audio signal from pin 14 of plug P601 is amplified by a-f amplifier I, V601A. The output of this stage is fed through the LOW-HIGH-ADJ switch, S601, connected between the plate circuit of tube V601A and the input circuit of tube V601B. The LOW-HIGH-ADJ switch inserts a low pass filter, Z601, for either low-or high-speed teletype signals or a calibration signal in the ADJ position.

Filter Z601 cuts off frequencies above those necessary for teletype reception. In the LOW position the filter response is flat within 6 decibels from 80 to 140 cycles and is down not less than 40 decibels from 240 cycles and above. However, capacitors C617 and C618 give an overall circuit response flat within 6 decibels from 80 to 125 cycles and down not less than 40 decibels from 200 cycles and above (these are approximate values only). In the HI position the filter response is flat within 6 decibels from 80 to 300 cycles and is down not less than 40 decibels from 500 cycles and above. However, capacitor C618 gives an overall circuit response flat within 6 decibels from 80 to 240 cycles and down not less than 40 decibels from 415 cycles and above (these are approximate values only).

The output of the A-F Amplifier II tube, V601B, is applied to the control grid, pin 2, of the Trigger Driver tube V602B, through capacitor C616 and resistor R605. This same signal is fed to the Tuning Monitor Unit through pin 5 of plug P601 to indicate the proper setting of the THRESHOLD control in the I-F Unit. When the THRESHOLD control is properly adjusted, this voltage should be approximately 17 volts peak-to-peak. The traces on the oscilloscope tube will then coincide with the top and bottom engraved lines on the Tuning Monitor Unit window when the CAL IN switch, S701, is depressed. Accuracy of the trace indication can be checked by setting the LOW-HI-ADJ switch, S601, to the ADJ position and observing the traces to coincide with the top and bottom lines on the window when the CAL IN button is depressed.

Connected between the grid of the Trigger Driver tube, V602B, and ground is a d-c restorer tube, V606, with its associated circuits. This circuit selects a portion from the output of tube V601B near the zero-voltage axis, eliminating the superimposed noise and telegraph distortion. This is accomplished by two diodes, one of which (pins 1 and 7) clips the negative portion and the other (pins 2 and 5), positively biased, clips the signal level above four volts. Therefore, appearing on the grid, pin 2, of the trigger driver, V602B, is a four-volt peak-to-peak square wave of plus two volts average. This square wave is identical to the discriminator square-wave output, except that the amplitude-modulated noise has been reduced and the d-c component has been removed by capacitive coupling.

In normal frequency shift teletypewriter operation the teletypewriter loop circuit is closed during the standby, or mark signal. This keeps the teletypewriter in condition to receive coding pulses which key the teletypewriter loop circuit through the keying tubes V607 and V608. The d-c component from the discriminator could be used to return the output tubes to conduction after each coding pulse has been received; however, since this component has been removed, a mark-return circuit is provided at the control grid of the trigger driver, V602B, to accomplish this result.

The mark-return circuit has a normal and a reverse position and consists of resistor R610 and switch S603B. This switch is used in the NORM position when the detected audio output from the receiver returns to a higher frequency in the mark or standby position. This permits the grid of tube V602B to return to plus four volts through resistor R610 and causes the output tubes, V607 and V608, to conduct. The REV position of switch S603B is used when the receiver output returns to a lower frequency and permits the control grid of tube V602B to return to zero voltage.

The output signal of tube V602A is direct coupled to an Eccles-Jordan flip-flop stage, V603A, B, which in turn, is coupled to another Eccles-Jordan flip-flop stage, V604A, B, having two stable positions. The output, taken from the grids of the second stage, V604A, B, is fed into the control grids of the output tubes, V607 and V608 through relay K601 and the NORM-REV switch S603A.

The pulse appearing in the teletypewriter loop circuit must be an exact duplicate of the pulse appearing at the discriminator output to prevent loss of printing margin on the teletypewriter. The Keyer Unit is provided with a MARK control, R613, located in the cathode circuit of tube V602B; this permits adjustment of the operating bias of this tube to obtain linear amplification of the pulse appearing on its grid and thereby minimize distortion of these pulses.

This control is adjusted to give a symmetrical square wave in the teletypewriter loop circuit with the LOW-HIGH-ADJ switch in the ADJ position. The detailed procedure is given in Section 3, paragraph 7a (20) of NAVSHIPS 91355.

The output tubes, V607 and V608, obtain their plate voltage and current from a power supply located in the Exciter-Filter-Relay Unit, through the tele-

typewriter and are controlled by the negative pulses received from the grids of the second trigger stage, V604A, B.

## 22. TUNING MONITOR UNIT.

For the theory of operation of the Tuning Monitor Unit use paragraph 8 on page 2-5 of NAVSHIPS 91355. The only difference in this chassis as compared to the chassis supplied for the CV-57/URR is a difference in lead dress to reduce the induced hum from the a-c power supply of 400 cycles compared to 60 cycles.

## 23. POWER SUPPLY UNIT.

For the theory of operation of the Power Supply Unit see paragraph 9, page 2-6 of NAVSHIPS 91355. The fan supply, while connected is not used. The +150 volts does not supply the tone oscillator since this is not used in this equipment.

# SECTION E

## MAINTENANCE

## 24. GENERAL.

This section gives instructions for routine and emergency maintenance, system and chassis trouble shooting and alignment procedures. A large portion of the maintenance procedures will be referenced to the Instruction Book for Frequency Shift Converter CV-57/URR, NAVSHIPS 91355, since a number of operations are unchanged and other operations have minor changes. New voltage and resistance tables are included in this section where necessary. Installation, block and schematic diagrams for the Adapter, Radio Teletype UG-(XA-4)/U are located in Section G and should be referred to along with the maintenance procedures.

## 25. ROUTINE MAINTENANCE.

For routine maintenance procedures see Section 5, Operator's Maintenance page 5-1 and Section 6, Preventive Maintenance page 6-1. Due to changes in the equipment make the following changes in procedures:

a. Fuses. On page 5-1, paragraph 2a, of NAVSHIPS 91355 refers to replacing fuses. No fuses are used in the Adapter, Radio Teletype UG-(XA-4)/U. However circuit breakers, external to the equipment, are used, one for the 27.5-volt supply and one for the 115-volt supply. These circuit breakers may be located at the equipment or on the aircraft breaker panel, depending on the particular installation.

b. Figures 5-3 and 7-9. Tubes V607 and V608 are type 6AK6 instead of 6AQ5. Tube V605 is no longer used being replaced by a new item, relay K601. Switch S604 is no longer used.

c. System Sensitivity. On page 6-1, paragraph 1C (1) use a frequency of 300 kilocycles for checking system sensitivity of the Adapter, Radio Teletype UG-(XA-4)/U.

d. 1/2 MARK Check. On page 6-2, paragraph 1f (7) the alternate procedure cannot be used since the tone oscillator is not used in the Adapter, Radio Teletype UG-(XA-4)/U.

e. MOD BAL Check and Gate Balance Adjustment. These adjustments, given in paragraphs 1g and 1h on page 6-2 are not applicable to the equipment described in this book.

f. Teletypewriter Loop Current Adjustment. Paragraph 1i on page 6-3 is correct except change the value of 60 ma to 30 ma and make the adjustment by varying resistor R1125 in the Exciter-Filter-Relay Unit.

g. Adjustment After Replacement of D-C Amplifier, V903. This paragraph only refers to the AN/URA-6 and AN/URA-7 equipments.

h. Lubrication. Paragraph 3 Lubrication is applicable to the Adapter, UG-(XA-4)/U.

## 26. CORRECTIVE MAINTENANCE.

Corrective maintenance procedures, where applicable, will be referred to in Section 7 of NAVSHIPS 91355 instruction book. Other maintenance procedures, applicable to the Adapter UG-(XA-4)/U and the associated voltage and resistance charts are given in this book. Use the information on page 7-1 of NAVSHIPS 91355 as a guide for the fundamental procedures. The photograph, figure 7-1, shows how the drawer can be made accessible for tests. Interconnections between drawer and Exciter-Filter-Relay Unit are made by jumper cable supplied. Do not slide the drawer out of the case unless the case is firmly fastened to the support.

27. LOCALIZING TROUBLE, ADAPTER, RADIO TELETYPE UG-(XA-4)/U. Use table 7-1 of NAVSHIPS 91355 on page 7-3. Change "fuses" to "circuit breakers" and delete "check for keyed tone at phones J1402". Proceed as follows:

a. Check power is on (circuit breakers closed and panel lamp is lighted).

b. If two lines appear on the tuning monitor tube while receiving frequency-shift signals and can be made to merge by reducing the radio receiver gain to zero, the Input Unit and I-F Unit are operating.

c. Press the CAL IN button. Two flickering lines on the tuning monitor tube indicates proper operation of circuits up to and including tube V601B in the Keyer Unit.

d. Plug a 0-50 or 0-100 ma milliammeter (connected to a phone plug with the tip to the meter "minus" and the shank to the meter "plus") into the TTYP jack on the front panel. A reading of about 30 milliamperes on the milliammeter, indicates correct circuit adjustment. The voltage to ground,

measured by a d-c voltmeter, should be about 78 volts. These indications will show the output tubes of the Keyer Unit are conducting but not keying.

e. Replace the unit that the above tests have shown to be defective with one known to be good. Most troubles in any of the units can be located by replacing tubes as described in paragraph 2b on page 5-2 of NAVSHIPS 91355 or by checking voltages and resistance values within that unit. Troubles in the Exciter-Filter-Relay Unit, Power Supply Unit or the Tuning Monitor Unit can best be located by continuity checks. See later paragraphs in this section for procedures referring to the individual units.

## 28. UNIT TROUBLE SHOOTING AND REPAIR.

a. Equipment Required. The equipment for trouble shooting should consist of the following:

- (1) A multimeter of 20,000 ohms-per-volt sensitivity.
- (2) An electronic voltmeter for a-c voltage measurements.
- (3) An electronic multimeter for d-c voltage measurements.
- (4) An oscilloscope similar to the type OS-8/U.
- (5) An adjustable signal generator such as R-F Signal Generator Set AN/URM-25. Minimum range 40 to 300 kilocycles with an output impedance of approximately 70 ohms.
- (6) An accurate frequency counter or precise frequency meter.
- (7) A 14-conductor cable approximately 4 feet long with a 14-prong plug on one end and a 14-prong jack on the other end to match the connectors for the operating sub-assemblies. This will enable trouble shooting the sub-chassis on the bench external to the equipment.
- (8) Use the equipment itself for servicing during non-operating periods. Where continuous operation is required, a separate maintenance system, comparable to the equipment in use, may be desirable.
- (9) Tools normally used in the electronic technician's work will be satisfactory for this work.

### NOTES

1. Before attempting to remove the individual units controlled by panel knobs, pull the panel knobs outward to disengage the mechanical coupling. After the unit has been re-seated, in the chassis, merely pushing the knobs will engage the mechanical couplers if the settings have not been disturbed; otherwise it will be necessary to push and turn the knobs to engage the couplings.
2. Remove the chassis by unscrewing the rear screws and then the front screw. Replace the units by tightening the front screw first and then the rear screws.

b. Exciter-Filter-Relay Unit. See figures 1 and 2 for location of components. Check circuits containing filters, relay contacts and relay coils using an ohmmeter. Use the schematic diagram, figure 5 as a guide for the

Exciter-Filter-Relay Unit and figure 4 for the associated circuits. Check the crystal oven for continuity while cold. Trouble in the fan motor, B1101, can best be remedied by replacing either the motor or its associated capacitor. Check the voltage and resistance values given in table E-1. Values varying more than 20 percent from those given in the table should be corrected by replacing tubes components, or realignment. The voltage measurements can be made using the jumper or test cable with the Exciter-Filter-Relay Unit. Resistance values are made using an ohmmeter with the Exciter-Filter-Relay Unit disconnected from the Adapter, Radio Teletype UG-(XA-4)/U and external circuits.

When alignment is required use the following procedure:

(1) Connect the r-f vacuum tube voltmeter to the space oscillator plate, pin 1 of tube V1101. Adjust transformer Z1101 by turning stud to give maximum voltage on the voltmeter. Turn stud outward until meter reads 90 per cent of maximum value. This will be the stable position of the oscillator.

(2) Connect the r-f vacuum tube voltmeter to the mark oscillator plate, pin 6 of tube V1101. Adjust transformer Z1102 by turning stud to give maximum voltage on the voltmeter. Turn stud outward until meter reads 90 per cent of maximum voltage reading for stable operation.

(3) Set frequency of space oscillator to 498.9375 kilocycles, by adjusting trimmer capacitor C1102, to within five or six cycles. Use frequency counter or precise frequency meter.

(4) Set frequency of mark oscillator to 501.0625 kilocycles, by adjusting trimmer capacitor C1101, to within five or six cycles. Use frequency counter or precise frequency meter.

(5) Repeat steps (1) and (2).

(6) Connect r-f voltmeter to plate, pin 5, of tube V1102 or V1103 and resonate transformer Z1103 for equal voltage from both mark and space oscillators. The space gate, tube V1103, will be open when pin C of jack J1102 is ungrounded. The mark gate, tube V1102, will be open when pin C of jack J1102 is grounded.

(7) Connect the vertical oscilloscope plates to the cathode follower section of tube V1104, pin 3 to ground or jack J1105. Connect signal generator output to the mixer grid, pin 7, of mark gate tube V1102. Connect horizontal input of oscilloscope to output of signal generator. Set signal generator output at two volts. Connect a 0.1 microfarad capacitor from plate, pin 5, of tube V1102 to ground. Set signal generator frequency precisely to 100 kilocycles and adjust transformer Z1104 until a one-to-one Lissajou's pattern is observed on the oscilloscope.

(8) Remove 0.1 microfarad capacitor from plate, pin 5, of tube V1102 and connect signal generator to pin 7 of tube V1102.

(9) Set signal generator frequency to 500 kilocycles. Adjust output transformer of tube V1102 same as given in step (6). A five-to-one Lissajou's pattern should be seen on the oscilloscope.

(10) Vary signal generator frequency above and below 500 kilocycles. Pattern on oscilloscope should lock-in symmetrically about the 500-kilocycle frequency. If it does not adjust transformer Z1104 until it does.

(11) Remove signal generator cable from pin 7 of tube V1102. Connect horizontal plates of oscilloscope to pin 7 of tube V1102. The pattern on the oscilloscope should be five-to-one and locked in.

TABLE E-1. EXCITER-FILTER-RELAY UNIT VOLTAGE

AND RESISTANCE MEASUREMENTS

All resistance measurements made with chassis removed and disconnected.

All voltage measurements made in transmit condition using vacuum tube voltmeter.

D-C voltage measurements M=mark S=space \*A-C voltage power line frequency

TUBE	1	2	3	4	5	6	7	8	9
V1101	M 76	2.5	7.0			76	2.5	7.0	
	S 76	2.5	7.0			76	2.5	7.0	
V1102	M -0.4	0			160	16	0	--	--
	S -43	0			160	150	0	--	--
	M -18.5	0			160	150	0	--	--
V1103	S -0.5	0			160	12	0	--	--
	M 180	0	3.5			110	-5.7	0	
V1104	S 180	0	3.5			110	-5.7	0	

A-C voltage measurements

V1101	M 35	6.0	1.5	3.1*	3.1*	35	6.0	1.5	3.1*
V1102	M 0.0	0.0	3.1*	3.1*	16	0.0	2.3	--	--
V1103	M 0.0	0.0	3.1*	3.1*	16	0.0	2.3	--	--
V1104	M 0.0	1.1	0.7	3.1*	3.1*	45	4.5	0.0	3.1*

Resistance measurements Meg=megohm K=1000 ohms INF=infinity

V1101	1.2 Meg	105K	4.7K	INF	INF	1 Meg	105K	4.7K	INF
V1102	100K	0	INF	INF	1 Meg	1 Meg	0.5	--	--
V1103	350K	0	INF	INF	1 Meg	1 Meg	0.5	--	--
V1104	1 Meg	47K	3.9K	INF	INF	1 Meg	100K	0	INF

Resistance jack J1101 to ground

Pin	1	2	3	4	5	6	7	8	9	10
Resistance										
Pin	11	12	13	14	15	16	17	18	19	20
Resistance										



(12) Key the teletype circuit and observe the 100-kilocycle output at jack J1105. Use sawtooth time base on the oscilloscope with a sweep frequency of 10 cycles per second. No amplitude or frequency modulation should be visible.

(13) Adjust the teletypewriter loop circuit by setting the teletypewriter to "receive" and adjust the sliding tap on resistor R1125 for a loop current of 30 milliamperes. The milliammeter on the teletypewriter can be used for this measurement or an external milliammeter plugged into the TYP jack on the Adapter, Radio Teletype UG-(XA-4)/U front panel. This completes the alignment.

c. Power Supply. Use the information for the Converter Power Supply, paragraph 2C on page 77 of NAVSHIPS 91355. No changes are made in this unit for use in the adapter but changes are made in the external circuits. For these circuits see the schematic diagram figure 4 in this book.

d. Tuning Monitor. Use the information given in paragraph 2d on page 7-7 of NAVSHIPS 91355. Before making repairs note changes to lead dress of the grid and plate leads as these changes in lead dress are the only differences from the Tuning Monitor described in NAVSHIPS 91355.

e. Input Unit. Use the information given in paragraph 2e on page 7-8 of NAVSHIPS 91355. Use an input frequency of 300 kilocycles, otherwise information is correct.

f. I-F Unit. Use the information given in paragraph 2h on page 7-8 of NAVSHIPS 91355.

g. Keyer Unit. Use the information given in paragraph 2g on page 7-8 of NAVSHIPS 91355. The following changes have been made:

(1) Switch S604 is not connected.  
(2) Tube V605, the tone oscillator and tone modulator is no longer used.

(3) Tube V602A, the balanced modulator, and the associated MOD BAL control R633 are no longer used. The heater of this tube section has been disconnected.

(4) A new relay, K601, has been added and is mounted in place of tube V605. Relay K601 switches the input signal to the keyer tubes, V607 and V608, from the receiver to the teletypewriter coder during transmission so the teletypewriter printer can be used to monitor the transmissions.

(5) The keyer tubes, V607 and V608, are type 6AK6.

(6) Use figure 4 of this book for the schematic diagram.

The trouble shooting procedure given in NAVSHIPS 91355 is correct except disregard the reference to switch S604 and paragraph (6) for tone oscillator check. Use the new table, E-2, in this book, for voltages and resistance values pertaining to the Keyer Unit changes. Table E-3 in this book amends Table 7-11, Tube Operating Voltages and Currents.

TABLE E-2. TUBE OPERATING VOLTAGES AND CURRENTS

AMENDED FOR UG-(XA-4)/U

TUBE	PLATE VOLTS	PLATE MA	SCREEN VOLTS	SCREEN MA	SUPPRESSOR VOLTS	CATHODE VOLTS	GRID VOLTS	HEATER VOLTS AC
V607f	+78	12.0	+78	3.0	0.0	0.0	0.0	6.3
V608f	+78	12.0	+78	3.0	0.0	0.0	0.0	6.3
V1101A	+75	*1.5	-	-	-	+7.0	+2.5	6.3
V1101B	+75	*1.5	-	-	-	+7.0	+2.5	6.3
V1102	+160	0.91	+16	0.95	0.0	0.0	-0.4	6.3
V1103	+160	0.91	+12	0.95	0.0	0.0	-0.5	6.3
V1104A	+110	3.15	-	-	-	0.0	-5.5	6.3
V1104B	+180	1.25	-	-	-	3.5	0.0	6.3

\*Represents a-c volts

With TTYP plug inserted

TABLE E-3. KEYER UNIT VOLTAGE AND RESISTANCE MEASUREMENTS

UG-(XA-4)/U

Voltage measurements to chassis ground (volts)

TUBE	1	2	3	4	5	6	7	8	9
601	105	0.0	2.25	3.1*	3.1*	55	0.0	2.1	3.1*
602	42	4.0 <del>f</del>	6.0	3.1*	3.1*	NOT USED			3.1*
603	158	42	65	3.1*	3.1*	120	62	65	3.1*
604	16.5	1.7	1.6	3.1*	3.1*	105	-23	1.6	3.1*
606	4.0 <del>f</del>	4.0 <del>f</del>	3.1*	3.1	4.6*	-	0.0	-	-
607	0.0	0.0	3.1*	3.1*	78 <del>f</del>	78 <del>f</del>	0.0	-	-
608	0.0	0.0	3.1*	3.1*	78 <del>f</del>	78 <del>f</del>	0.0	-	-

RESISTANCE MEASUREMENTS TO CHASSIS GROUND (OHMS K=1000 ohms)

601	INF	1.8 Meg	390	56K	56K	INF	1.8 Meg	1.8 Meg	56K
602	300K	1 Meg	5.5K	56K	56K	150K	INF	900	56K
603	130K	300K	19K	56K	56K	140K	72K	19K	56K
604	INF	INF	1000	56K	56K	INF	INF	1000	56K
606	1 Meg	1 Meg	56K	56K	5.6K	-	0.0	-	-
607	INF	0.0	56K	56K	INF	INF	0.0	-	-
608	INF	0.0	56K	56K	INF	INF	0.0	-	-

RESISTANCE MEASUREMENTS TO CHASSIS GROUND

P601			
PIN	RESISTANCE	PIN	RESISTANCE
1	56K	8	INF
2	125K	9	500
3	INF	10	INF
4	INF	11	0.0
5	INF	12	INF
6	INF	13	0.0
7	56K	14	INF

\*A-C volts

~~f~~Measured with electron-tube voltmeter

## SECTION F

## SUPPLEMENTARY INFORMATION

## 29. TUBE COMPLEMENT.

The following listed tubes are used in the Adapter, Radio Teletype UG-(XA-4)/U:

Symbol	Type	Location	Function
V101	JAN6C4	Input Unit	Conversion Oscillator
V102	JAN6AU6		Automatic frequency control
V103	JAN6BE6		Frequency converter
V301	JAN6AU6	I-F Unit	1st intermediate frequency amplifier
V302	JAN6AU6		Limiter
V303	JAN6AL5		Discriminator
V601	JAN12AU7	Keyer Unit	Amplifier I
V602	JAN12AU7		Amplifier II
V603	JAN12AU7		Trigger driver
V604	JAN12AU7		Not used
V605	JAN12AU7		Trigger I
V606	JAN12AU7		Trigger I
V607	JAN12AU7		Trigger II
V608	JAN12AU7		Trigger II
V609	-----		Not used
V606	JAN6AL5		D-C Restorer
V607	JAN6AK6		D-C Restorer
V608	JAN6AK6		Teletype keyer
V609	JAN6AK6		Teletype keyer
V701	JAN12AX7	Tuning Monitor Unit	Vertical Amplifier
V702	JAN2BP1		Vertical Amplifier Indicator
V801	JAN1Z2	Power Supply Unit	High voltage rectifier
V802	JAN6X4		Low voltage rectifier
V803	JANQA2		Voltage regulator
V1101	JAN12AU7	Exciter-Filter-Relay Unit	Mark oscillator
V1102	JAN6BE6		Space oscillator
V1103	JAN6BE6		Mark gate
V1104	JAN12AT7		Space gate
			Locked-in oscillator
			Cathode follower

## 30. PHOTOGRAPHS.

Following are photographs of the Exciter-Filter-Relay Unit to aid in identifying and locating items of equipment and their relative location.

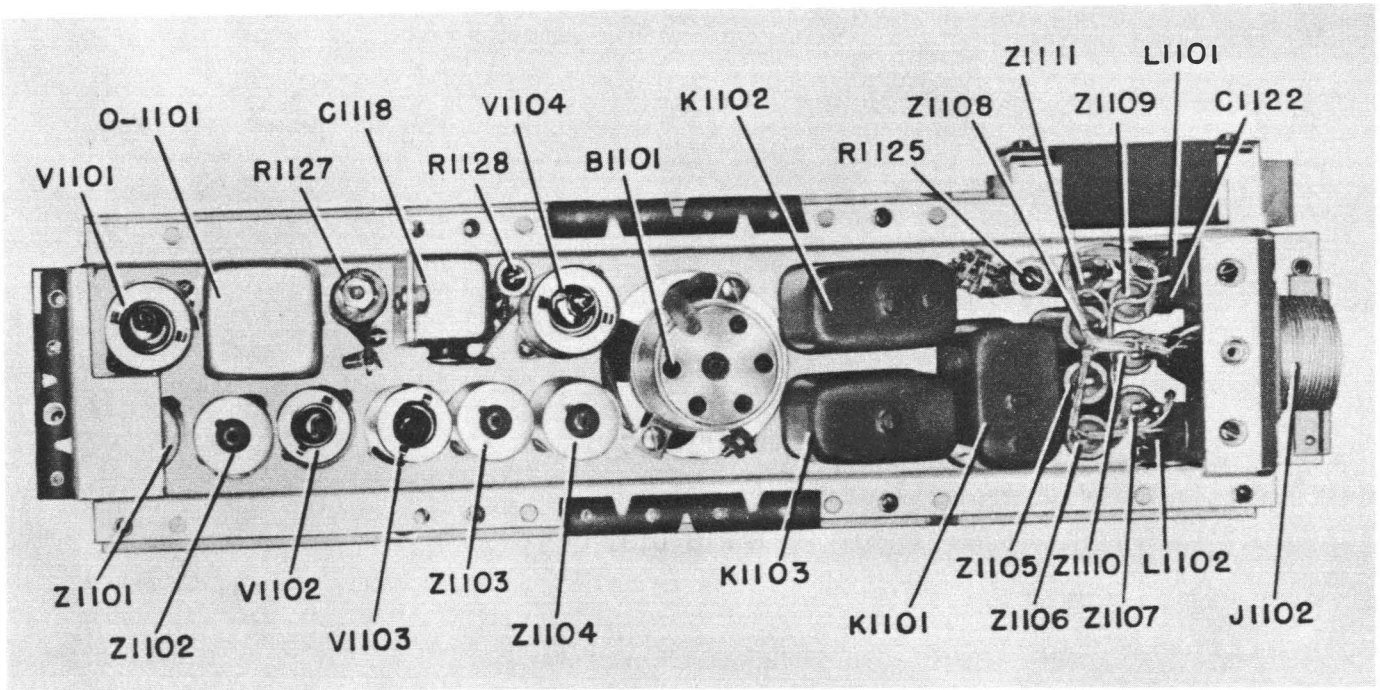

Figure 1. Exciter-Filter-Relay Unit, Top View

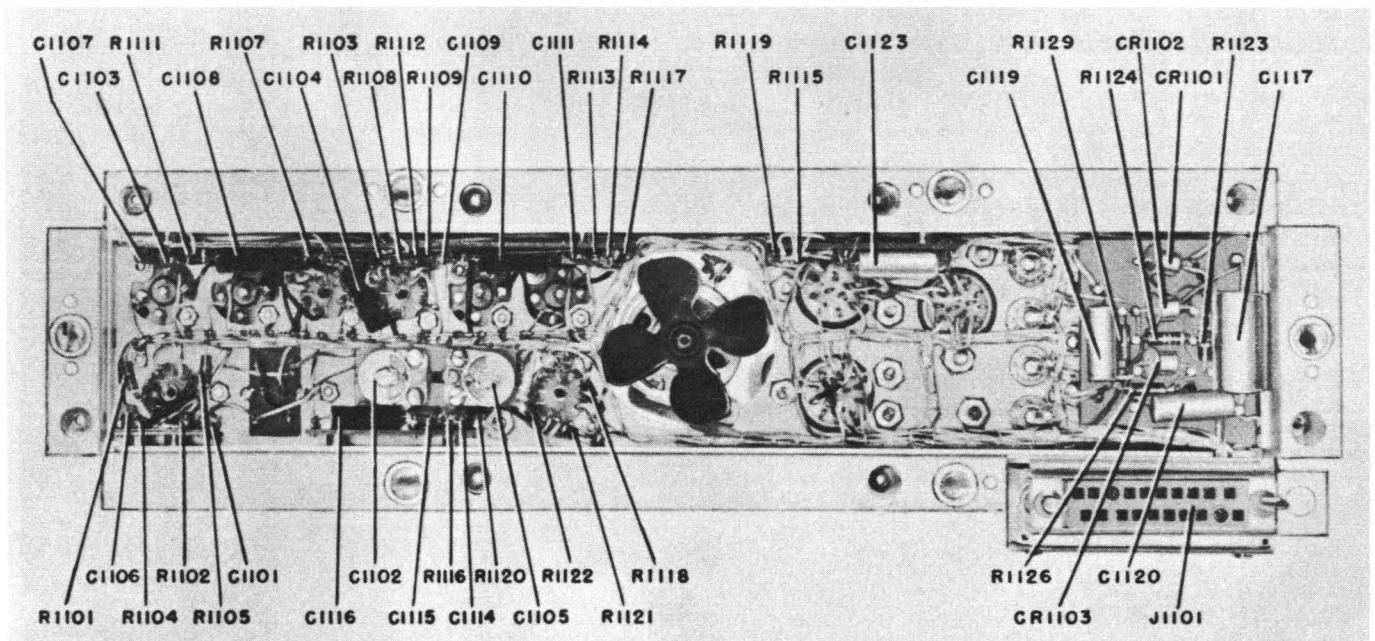

Figure 2. Exciter-Filter-Relay Unit, Bottom View

SECTION G

PARTS LIST

# LIST OF PARTS

A 8866700

COMP. BY *A. N. Coraggio Mar. 22, 1954*

CHECKED BY

SHEET CONT'D. ON SHEET

**DRAWING TITLE**  
  
EXCITER FILTER RELAY UNIT  
  
Sheet 1 of 10 sheets

USED ON	FIRST MADE FOR				
UG(XA-4)/U		501			

RADIO CORPORATION OF AMERICA, RCA VICTOR DIVISION, CAMDEN, N. J.

ITEM OR SYMBOL	RCA REFERENCE		DESCRIPTION	GOV. REFERENCE		QTY.	QTY.	QTY.	QTY.
	DRAWING	PART OR GROUP		RCA	OTHER MFGS. AN, JAN, ETC.				
B1101	471929	1	FAN MOTOR			1			
C1101	990162	239	CAPACITOR, MICA 470 MMF 10%			1			
C1102	8886252	3	CAPACITOR, TRIMMER 5-20 MMF			1			
C1103	990162	240	CAPACITOR, MICA 510 MMF 5%			1			
C1104	737816	49	CAPACITOR, OIL .022 MFD 200V.			1			
C1105	8886252	3	CAPACITOR, TRIMMER 5-20 MMF			1			
C1106	990162	239	CAPACITOR, MICA 470 MMF 10%			1			
C1107	990162	240	CAPACITOR, MICA 510 MMF 5%			1			
C1108	737816	49	CAPACITOR, OIL .022 MFD 200V.			1			
C1109	990162	239	CAPACITOR, MICA 470 MMF 5%			1			
C1110	737816	49	CAPACITOR, OIL .022 MFD 200V. 10%			1			
C1111	990162	237	CAPACITOR, MICA 390 MMF 10%			1			
C1112	737816	334	CAPACITOR, MICA 150 MMF 5%			1			
C1113	737816	49	CAPACITOR, OIL .022 MFD 200V. 10%			1			
C1114	743252	210	CAPACITOR, MICA 10 MMF 10%			1			
C1115	990162	235	CAPACITOR, MICA 330 MMF 10%			1			
C1116	737816	49	CAPACITOR, OIL .022 MFD 200V. 10%			1			
C1117	737816	293	CAPACITOR, OIL .1 MFD 600V. 10%			1			
C1118	723672	10	CAPACITOR, ELECTROLYTIC 20 MFD 150V.			1			
C1119	737875	152	CAPACITOR, ELECTROLYTIC 2 MFD 100V. 10%			1			
C1120	737875	152	CAPACITOR, ELECTROLYTIC 2 MFD 100V. 10%			1			
C1121	737816	147	CAPACITOR .01 MFD 600V. 10%			1			
C1122	458501	13	CAPACITOR, CERAMIC .05 MFD 250V. 20%			1			
C1123	737816	147	CAPACITOR .01 MFD 500V. 10%			1			

THESE DRAWINGS AND SPECIFICATIONS ARE THE PROPERTY OF RADIO CORPORATION OF AMERICA, RCA VICTOR DIVISION, AND SHALL NOT BE REPRODUCED, OR COPIED, OR USED AS THE BASIS FOR THE MANUFACTURE OR SALE OF APPARATUS OR DEVICES WITHOUT PERMISSION.

REVISIONS	0		
	AP. BY		
	AP. MFG.		

8866700

RADIO CORPORATION OF AMERICA, RCA VICTOR DIVISION CAMDEN, N. J.

# LIST OF PARTS

A | 8866700

COMP. BY *A. R. Campio, Mar. 22, 1954*

CHECKED BY

SHEET CONT'D. ON SHEET

DRAWING TITLE

EXCITER FILTER RELAY UNIT

USED ON

UG(XA-4)/U

FIRST MADE FOR

501

Sheet 2 of 30 sheets

ITEM OR SYMBOL	RCA REFERENCE		DESCRIPTION	GOV. REFERENCE		QTY.	QTY.	QTY.	QTY.
	DRAWING	PART OR GROUP		RCA	OTHER MFGS. AN, JAN, ETC.				
CR1101			RECTIFIER 1N93			1			
CR1102			RECTIFIER 1N93			1			
CR1103			RECTIFIER 1N93			1			
E1101	471938	501	TERMINAL BOARD			1			
E1102	8864485	501	TERMINAL BOARD			1			
E1103	8865944	501	TERMINAL BOARD			1			
E1104	8864486	501	TERMINAL BOARD			1			
E1105	8865945	501	TERMINAL BOARD			1			
E1106	471984	501	TERMINAL BOARD			1			
J1101	8738961	2	SOCKET 20 PIN			1			
J1102	737841	100	RECEPTACLE			1			
J1103	445813	1	RECEPTACLE, CO-AX UG-290/U			1			
J1104	445813	1	RECEPTACLE, CO-AX UG-290/U			1			
J1105	445813	1	RECEPTACLE, CO-AX UG-290/U			1			
K1101	629482	4	RELAY			1			
K1102	629482	4	RELAY			1			
K1103	629482	4	RELAY			1			
L1101	886754	1	FILTER INDUCTANCE			1			
L1102	886754	1	FILTER INDUCTANCE			1			
O1101	471141	501	OVEN, CRYSTAL			1			

THESE DRAWINGS AND SPECIFICATIONS ARE THE PROPERTY OF RADIO CORPORATION OF AMERICA, RCA VICTOR DIVISION, AND SHALL NOT BE REPRODUCED, OR COPIED, OR USED AS THE BASIS FOR THE MANUFACTURE OR SALE OF APPARATUS OR DEVICES WITHOUT PERMISSION.

REVISIONS	0				
	AP. BY				
	AP. MFR.				

8866700



# LIST OF PARTS

# A 8866700

 COMP. BY  
*A. W. [Signature] Mar. 22, 1957*

CHECKED BY

SHEET CONT'D. ON SHEET

**DRAWING TITLE**

EXCITER FILTER RELAY UNIT

**USED ON**

UG(XA-4)/U

**FIRST MADE FOR**

801

Sheet 3 of 10 sheets

RADIO CORPORATION OF AMERICA, RCA VICTOR DIVISION CAMDEN, N. J.

ITEM OR SYMBOL	RCA REFERENCE		DESCRIPTION	GOV. REFERENCE		QTY.	QTY.	QTY.	QTY.
	DRAWING	PART OR GROUP		RCA	OTHER MFGS. AN, JAN, ETC.				
R1101	722320	70	RESISTOR 4700 OHMS $\pm 10\%$ 1/2 WATT	RC20GF472K		1			
R1102	722320	86	RESISTOR 100K OHMS $\pm 10\%$ 1/2 WATT	RC20GF104K		1			
R1103	722320	85	RESISTOR 82K OHMS $\pm 10\%$ 1/2 WATT	RC20GF823K		1			
R1104	722320	86	RESISTOR 100K OHMS $\pm 10\%$ 1/2 WATT	RC20GF104K		1			
R1105	722320	70	RESISTOR 4700 OHMS $\pm 10\%$ 1/2 WATT	RC20GF472K		1			
R1106	722320	85	RESISTOR 82K OHMS $\pm 10\%$ 1/2 WATT	RC20GF823K		1			
R1107	722320	86	RESISTOR 100K OHMS $\pm 10\%$ 1/2 WATT	RC20GF104K		1			
R1108	722320	89	RESISTOR 180K OHMS $\pm 10\%$ 1/2 WATT	RC20GF184K		1			
R1109	722320	97	RESISTOR 820K OHMS $\pm 10\%$ 1/2 WATT	RC20GF824K		1			
R1110	722320	86	RESISTOR 100K OHMS $\pm 10\%$ 1/2 WATT	RC20GF104K		1			
R1111	722320	91	RESISTOR 270K OHMS $\pm 10\%$ 1/2 WATT	RC20GF274K		1			
R1112	722320	89	RESISTOR 180K OHMS $\pm 10\%$ 1/2 WATT	RC20GF184K		1			
R1113	722320	81	RESISTOR 39K OHMS $\pm 10\%$ 1/2 WATT	RC20GF393K		1			
R1114	722320	92	RESISTOR 330K OHMS $\pm 10\%$ 1/2 WATT	RC20GF334K		1			
R1115	722320	72	RESISTOR 6.8K OHMS $\pm 10\%$ 1/2 WATT	RC20GF682K		1			
R1116	722320	75	RESISTOR 12K OHMS $\pm 10\%$ 1/2 WATT	RC20GF123K		1			
R1117	722320	85	RESISTOR 82K OHMS $\pm 10\%$ 1/2 WATT	RC20GF823K		1			
R1118	722320	86	RESISTOR 100K OHMS $\pm 10\%$ 1/2 WATT	RC20GF104K		1			

THESE DRAWINGS AND SPECIFICATIONS ARE THE PROPERTY OF RADIO CORPORATION OF AMERICA, RCA VICTOR DIVISION, AND SHALL NOT BE REPRODUCED, OR COPIED, OR USED AS THE BASIS FOR THE MANUFACTURE OR SALE OF APPARATUS OR DEVICES WITHOUT PERMISSION.

REVISIONS	O				
	AP. BY				
	AP. MFG.				

# 8866700

# LIST OF PARTS

A 8866700

COMP. BY *A. R. Curcio Mgr. 2/1/54*

CHECKED BY

SHEET CONT'D. ON SHEET

**DRAWING TITLE**

EXCITER FILTER RELAY UNIT

USED ON

UG(XA-4)/U

FIRST MADE FOR

501

Sheet 4 of 10 sheets

RADIO CORPORATION OF AMERICA, RCA VICTOR DIVISION CAMDEN, N. J.

ITEM OR SYMBOL	RCA REFERENCE		DESCRIPTION	GOV. REFERENCE			
	DRAWING	PART OR GROUP		RCA			
				QTY.	QTY.	QTY.	QTY.
R1119	722320	79	RESISTOR 27K OHMS $\pm 10\%$ 1/2 WATT	RC20GF273K	1		
R1120	722320	77	RESISTOR 18K OHMS $\pm 10\%$ 1/2 WATT	RC20GF183K	1		
R1121	722320	82	RESISTOR 47K OHMS $\pm 10\%$ 1/2 WATT	RC20GF473K	1		
R1122	722320	69	RESISTOR 3900 OHMS $\pm 10\%$ 1/2 WATT	RC20GF392K	1		
R1123	722320	82	RESISTOR 47K OHMS $\pm 10\%$ 1/2 WATT	RC20GF473K	1		
R1124	722320	82	RESISTOR 47K OHMS $\pm 10\%$ 1/2 WATT	RC20GF473K	1		
R1125	889725	6	RESISTOR 1000 OHMS VAR. $\pm 20\%$ 8 WATT		1		
R1126	722320	62	RESISTOR 1000 OHMS $\pm 10\%$ 1/2 WATT	RC20GF102K	1		
R1127	990650	31	RESISTOR 1000 OHMS $\pm 20\%$ 18 WATT		1		
R1128	990638	75	RESISTOR 500 OHMS $\pm 20\%$ 8 WATT		1		
R1129	722320	78	RESISTOR 22K OHMS $\pm 10\%$ 1/2 WATT	RC20GF223K	1		
S1101	8822868	2	THERMOSTAT, STEVENS 75°C PART OF 01101		X		

THESE DRAWINGS AND SPECIFICATIONS ARE THE PROPERTY OF RADIO CORPORATION OF AMERICA, RCA VICTOR DIVISION, AND SHALL NOT BE REPRODUCED, OR COPIED, OR USED AS THE BASIS FOR THE MANUFACTURE OR SALE OF APPARATUS OR DEVICES WITHOUT PERMISSION.

REVISIONS	0		
	AP. BY		
AP. MFG.			

8866700

# LIST OF PARTS

A 8866700

COMP. BY *A. N. Campio, Mar. 24, 1954*

CHECKED BY

SHEET CONT'D. ON SHEET

DRAWING TITLE

EXCITER FILTER RELAY UNIT

USED ON

UG (XA-4)/U

FIRST MADE FOR

501

Sheet 5 of 10 sheets

RADIO CORPORATION OF AMERICA, RCA VICTOR DIVISION CAMDEN, N. J.

ITEM OR SYMBOL	RCA REFERENCE		DESCRIPTION	GOV. REFERENCE							
	DRAWING	PART OR GROUP		RCA	OTHER MFGS.	AN, JAN, ETC.	QTY.	QTY.	QTY.	QTY.	
V1101			TUBE 12AU7				1				
V1102			TUBE 6BE6				1				
V1103			TUBE 6BE6				1				
V1104			TUBE 12AT7				1				
X1101	8889548	1	TUBE SOCKET 9 PIN MINIATURE				1				
X1102	99370	2	TUBE SOCKET 7 PIN MINIATURE				1				
X1103	99370	2	TUBE SOCKET 7 PIN MINIATURE				1				
X1104	8888548	1	TUBE SOCKET 9 PIN MINIATURE				1				
Y1101			CRYSTAL SPACE 498937.5 C.P.S.				1				
Y1102			CRYSTAL MARK 501062.5 C.P.S.				1				
Z1101	8819016	501	TRANSFORMER 500KC MARK OSCILLATOR				1				
Z1102	8819016	501	TRANSFORMER 500KC SPACE OSCILLATOR				1				
Z1103	8819017	501	TRANSFORMER 500KC GATE OUTPUT				1				
Z1104	8819018	501	TRANSFORMER 100KC LOCKED OSCILLATOR				1				
Z1105	463563	1	FILTER				1				
Z1106	463563	1	FILTER				1				
Z1107	463563	1	FILTER				1				
Z1108	463563	1	FILTER				1				
Z1109	463563	1	FILTER				1				
Z1110	463563	1	FILTER				1				
Z1111	463563	1	FILTER				1				

THESE DRAWINGS AND SPECIFICATIONS ARE THE PROPERTY OF RADIO CORPORATION OF AMERICA, RCA VICTOR DIVISION, AND SHALL NOT BE REPRODUCED, OR COPIED, OR USED AS THE BASIS FOR THE MANUFACTURE OR SALE OF APPARATUS OR DEVICES WITHOUT PERMISSION.

REVISIONS	0	
AP. BY		
AP. MFG.		

8866700

# LIST OF PARTS

A 8866700

COMP. BY  
*A. B. Long, Mar 23, 1954*

CHECKED BY

SHEET CONT'D. ON SHEET

**DRAWING TITLE**

EXCITER FILTER RELAY UNIT

Sheet 6 of 10 sheets

USED ON	FIRST MADE FOR				
UG(XA-4)/U		801			

RADIO CORPORATION OF AMERICA, RCA VICTOR DIVISION CAMDEN, N. J.

ITEM OR SYMBOL	RCA REFERENCE		DESCRIPTION	GOV. REFERENCE								
	DRAWING	PART OR GROUP		RCA	OTHER MFGS.	AN, JAN, ETC.	QTY.	QTY.	QTY.	QTY.		
1	318650	1	EXCITER FILTER RELAY						X			
2	634661	1	SCHEMATIC						X			
3	317505	1	CONNECTION DIAGRAM						X			
4												
5												
6												
7	634669	501	CHASSIS, FRAME							1		
8	634668	501	COVER, REAR							1		
9	751313	501	COVER ASSEMBLY							1		
10	471140	1	CLAMP MOTOR							1		
11	8866653	1	PIN							2		
12	3840044	1	GUIDE							1		
13	3331168	1	SPRING							2		
14	8895386	1	SHIELD							1		
15	8895324	1	COVER							1		
16	8865946	1	INSULATOR							2		
17	8865947	1	INSULATOR							2		
18	3362656	1	PLATE							1		
19	3335385	2	CONTACT - TUBE							6		
20	3362657	1	PLATE							1		
21	99147	2	SHIELD - TUBE							2		
22	8888549	1	SHIELD - TUBE							2		
23												
24												
25												
26	57453	153	MACH. SCREW #3-48 x 3/16 LG. BR. NI. PLT.							12		
27												
28	990314	157	SCREW-MACH. #4-40 x 5/16 LG. BD. HD. BR. NI. PLT.							8		
29	77381	108	SCREW-MACH. #4-40 x 1-3/4 LG. BD. HD. BR. NI. PLT.							2		
30	990314	159	SCREW-MACH. #4-40 x 3/8 LG. BD. HD. BR. NI. PLT.							7		
31	990314	155	SCREW-MACH. #4-40 x 1/4 LG. BD. HD. BR. NI. PLT.							13		

THESE DRAWINGS AND SPECIFICATIONS ARE THE PROPERTY OF RADIO CORPORATION OF AMERICA, RCA VICTOR DIVISION, AND SHALL NOT BE REPRODUCED, OR COPIED, OR USED AS THE BASIS FOR THE MANUFACTURE OR SALE OF APPARATUS OR DEVICES WITHOUT PERMISSION.

REVISIONS	AP. BY	AP. MFG.	DATE	DESCRIPTION
0				

8866700

# LIST OF PARTS

A 8866700

COMP. BY *A. H. Conroy, Mar-22-1954*

CHECKED BY

SHEET CONT'D. ON SHEET

DRAWING TITLE

USED ON

FIRST MADE FOR

EXCITER FILTER RELAY UNIT

UG (XA-4/U)

501

Sheet 7 of 10 sheets

ITEM OR SYMBOL	RCA REFERENCE		DESCRIPTION	GOV. REFERENCE							
	DRAWING	PART OR GROUP		RCA	OTHER MFGS.	AN, JAN, ETC.	QTY.	QTY.	QTY.	QTY.	
32	57454	155	SCREW-MACH. #4-40 x 1/4 LG. RD. HD. BR. NI. PLT.				21				
33											
34	57456	159	SCREW-MACH. #6-32 x 3/8 LG. RD. HD. BR. NI. PLT.				1				
35	8892377	2	SCREW #6-32 x 5/8 LG. PAN HD. PHILLIPS CROSS RECESSED STN. STL. PASSIV. DIP				8				
36											
37	990316	155	SCREW-MACH. #6-32 x 1/4 LG. BD. HD. BR. NI. PLT.				4				
38											
39	57458	182	SCREW-MACH. #8-32 x 2-1/8 LG. RD. HD. BR. NI. PLT.				2				
40	57458	184	SCREW-MACH. #8-32 x 2-3/8 LG. RD. HD. BR. NI. PLT.				1				
41											
42	93620	154	WASHER-LOCK #3 .198 OD x .101 ID x .025 THK. BR. NI. PLT.				12				
43	93620	155	WASHER-LOCK #4 .212 OD x .115 ID x .025 THK. BR. NI. PLT.				51				
44											
45	93620	157	WASHER-LOCK #6 .251 OD x .141 ID x .031 THK. BR. NI. PLT.				14				
46	93620	159	WASHER-LOCK #8 .296 OD x .163 ID x .040 THK. BR. NI. PLT.				3				
47											
48	82278	153	WASHER-FLAT #4 .120 ID x 9/32 OD x .025 THK. BR. WHT. NI. PLT.				10				

THESE DRAWINGS AND SPECIFICATIONS ARE THE PROPERTY OF RADIO CORPORATION OF AMERICA, RCA VICTOR DIVISION, AND SHALL NOT BE REPRODUCED, OR COPIED, OR USED AS THE BASIS FOR THE MANUFACTURE OR SALE OF APPARATUS OR DEVICES WITHOUT PERMISSION.

REVISIONS

0							
AP. BY	AP. MFR.						

8866700

RADIO CORPORATION OF AMERICA, RCA VICTOR DIVISION CAMDEN, N. J.

# LIST OF PARTS

A 8866700

COMP. BY *A. R. Campy Mar 23/1957*

CHECKED BY

SHEET CONT'D. ON SHEET

**DRAWING TITLE**  
  
EXCITER FILTER RELAY UNIT  
  
Sheet 8 of 10 sheets

USED ON	FIRST MADE FOR
UG(XA-4)/U	501

RADIO CORPORATION OF AMERICA, RCA VICTOR DIVISION CAMDEN, N. J.

ITEM OR SYMBOL	RCA REFERENCE		DESCRIPTION	GOV. REFERENCE						
	DRAWING	PART OR GROUP		RCA	OTHER MFGS.	AN, JAN, ETC.	QTY.	QTY.	QTY.	QTY.
49	82278	154	WASHER-FLAT #6 .147 ID x 3/8 OD x .032 THK. BR. WHT. NI. PLT.				1			
50	82278	155	WASHER-FLAT #8 .172 ID x 3/8 OD x .032 THK. BR. WHT. NI. PLT.				5			
51										
52	99077	17	WASHER-INSULATING 7/16 OD x .173 ID x .015 THK. MICA				4			
53	99077	18	WASHER-INSULATING 1/2 OD x 1/4 ID x .017 THK. MICA				2			
54	887277	4	WASHER "C" STN. STL. PASSIV. DIP				6			
55	67592	2	TERMINAL LUG #4				9			
56	67592	6	TERMINAL LUG #6				2			
57										
58	59158	122	NUT-HEX #4-40 3/16 FLAT x .066 THK. BR. NI. PLT.				16			
59	59158	154	NUT-HEX #6-32 5/16 FLAT x .109 THK. BR. NI. PLT.				14			
60	59158	155	NUT-HEX #8-32 x 11/32 FLAT x .125 THK. BR. NI. PLT.				3			
61										
62										
63										
64										
65										
66			WIRE WHT-BLK TR. 7/.008 300V. 18 LG. PS724-33				1			
67			WIRE WHT-BLU TR. 7/.008 300V. 8 LG. PS724-33				1			

THESE DRAWINGS AND SPECIFICATIONS ARE THE PROPERTY OF RADIO CORPORATION OF AMERICA, RCA VICTOR DIVISION, AND SHALL NOT BE REPRODUCED, OR COPIED, OR USED AS THE BASIS FOR THE MANUFACTURE OR SALE OF APPARATUS OR DEVICES WITHOUT PERMISSION.

REVISIONS	0				
	AP. BY	AP. MFR.			

8866700

# LIST OF PARTS

# A

 COMP. BY  
*A. N. Conzo, Mar. 22, 1957*

CHECKED BY

SHEET      CONT'D. ON SHEET

**DRAWING TITLE**  
  
 EXCITER FILTER RELAY UNIT  
  
 Sheet 9 of 10 sheets

USED ON	FIRST MADE FOR	801			
UG(XA-4)/U					

RADIO CORPORATION OF AMERICA, RCA VICTOR DIVISION CAMDEN, N. J.

ITEM OR SYMBOL	RCA REFERENCE		DESCRIPTION	GOV. REFERENCE				QTY.	QTY.	QTY.	QTY.
	DRAWING	PART OR GROUP		RCA	OTHER MFGS.	AN, JAN, ETC.					
68			WIRE WHT-GRN TR.      7/.008 300V. 12 LG.      PS724-33					1			
69			WIRE WHT-BRN TR.      7/.008 300V. 24 LG.      PS724-33					1			
70			WIRE WHT-ORN TR.      7/.008 300V. 12 LG.      PS724-33					1			
71			WIRE WHT-RED TR.      7/.008 300V. 24 LG.      PS724-33					1			
72			WIRE WHT-YEL TR.      7/.008 300V. 8 LG.      PS724-33					1			
73			WIRE WHT-BRN/RED TR.      7/.008 300V. 10 LG.      PS724-33					1			
74			WIRE WHT-RED/GRN TR.      7/.008 300V. 8 LG.      PS724-33					1			
75			WIRE WHT-RED/BLU TR.      7/.008 300V. 12 LG.      PS724-33					1			
76			WIRE WHT-YEL/GRN TR.      7/.008 300V. 24 LG.      PS724-33					1			
77			WIRE WHT-GRN/BRN TR.      7/.008 300V. 10 LG.      PS724-33					1			
78			WIRE WHT-GRN/RED TR.      7/.008 300V. 8 LG.      PS724-33					1			
79			WIRE WHT-BLU/RED TR.      7/.008 300V. 12 LG.      PS724-33					1			
80			WIRE WHT-RED/BLK TR.      7/.008 300V. 8 LG.      PS724-33					1			
81			WIRE WHT-YEL/BLK TR.      7/.008 300V. 8 LG.      PS724-33					1			
82			WIRE WHT 300V. 18 LG.      PS724-33					1			
83			WIRE TINNED COPPER .020 DIA. 30 LG.      PS105					1			
84			WIRE TINNED COPPER .050 DIA. 8 LG.      PS105					1			
85			SLEEVING BLK. .034 ID 30 LG.      8845688-3					1			

THESE DRAWINGS AND SPECIFICATIONS ARE THE PROPERTY OF RADIO CORPORATION OF AMERICA, RCA VICTOR DIVISION, AND SHALL NOT BE REPRODUCED, OR COPIED, OR USED AS THE BASIS FOR THE MANUFACTURE OR SALE OF APPARATUS OR DEVICES WITHOUT PERMISSION.

<b>REVISIONS</b>	0						
	AP. BY	AP. MFG.					





SECTION H

DRAWINGS

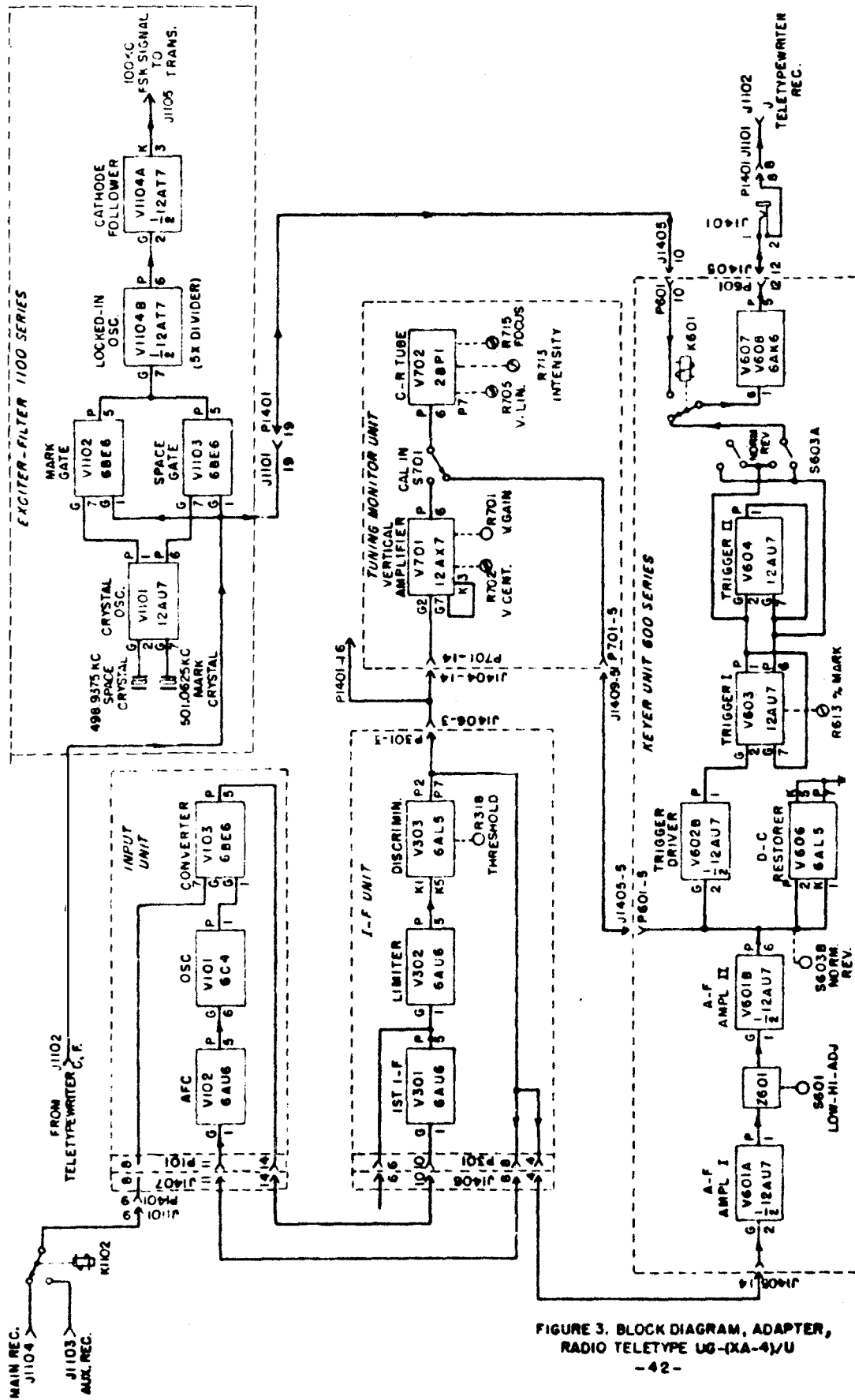

FIGURE 3. BLOCK DIAGRAM, ADAPTER, RADIO TELETYPE UG-(XA-4)/U

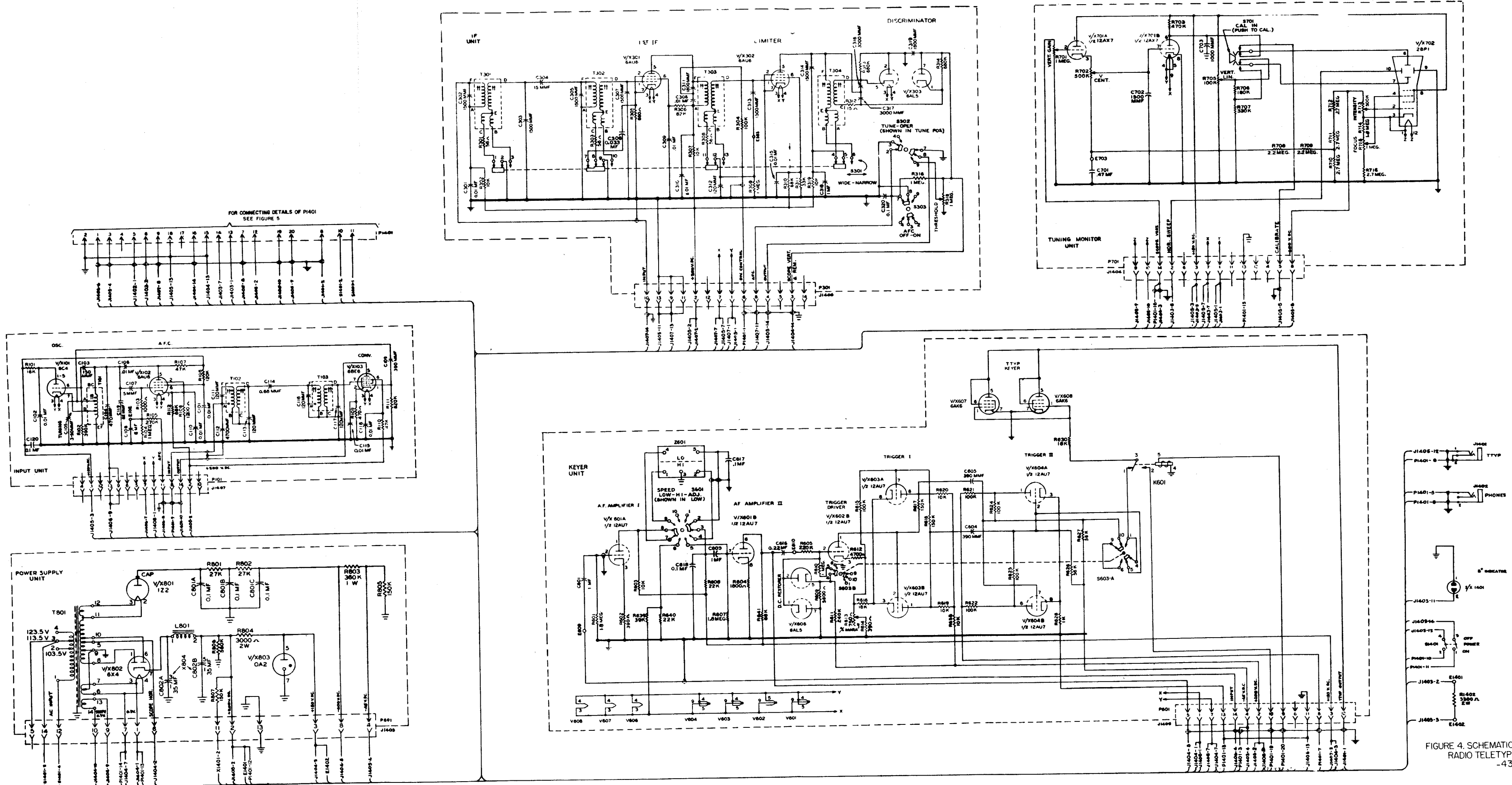

FIGURE 4. SCHEMATIC DIAGRAM, ADAPTER, RADIO TELETYPE UG-(XA-4)/U

NOTE:  
 1 O-1101(A),(B) IS ONE OVEN.

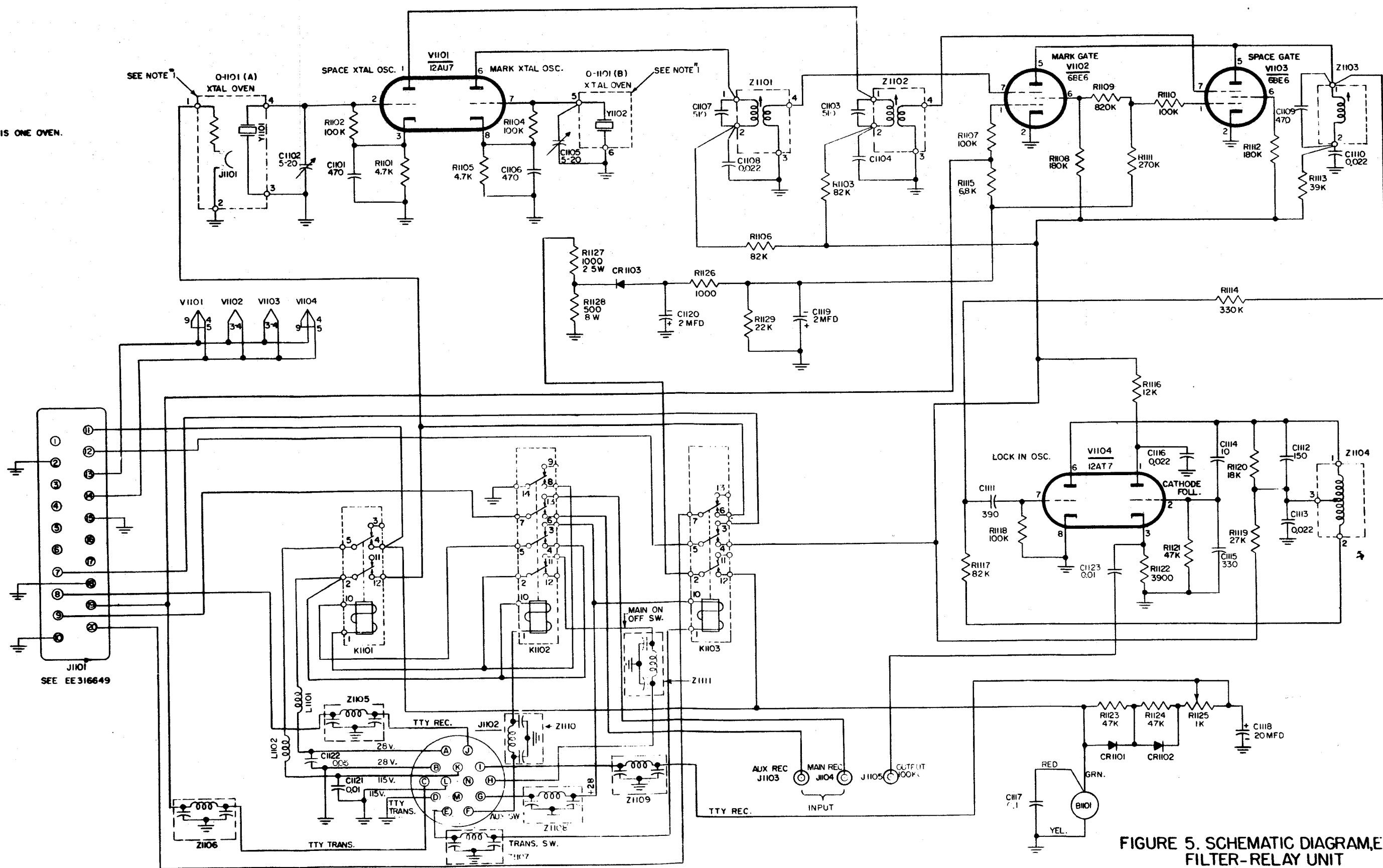

FIGURE 5. SCHEMATIC DIAGRAM, EXCITER FILTER-RELAY UNIT  
 -44-

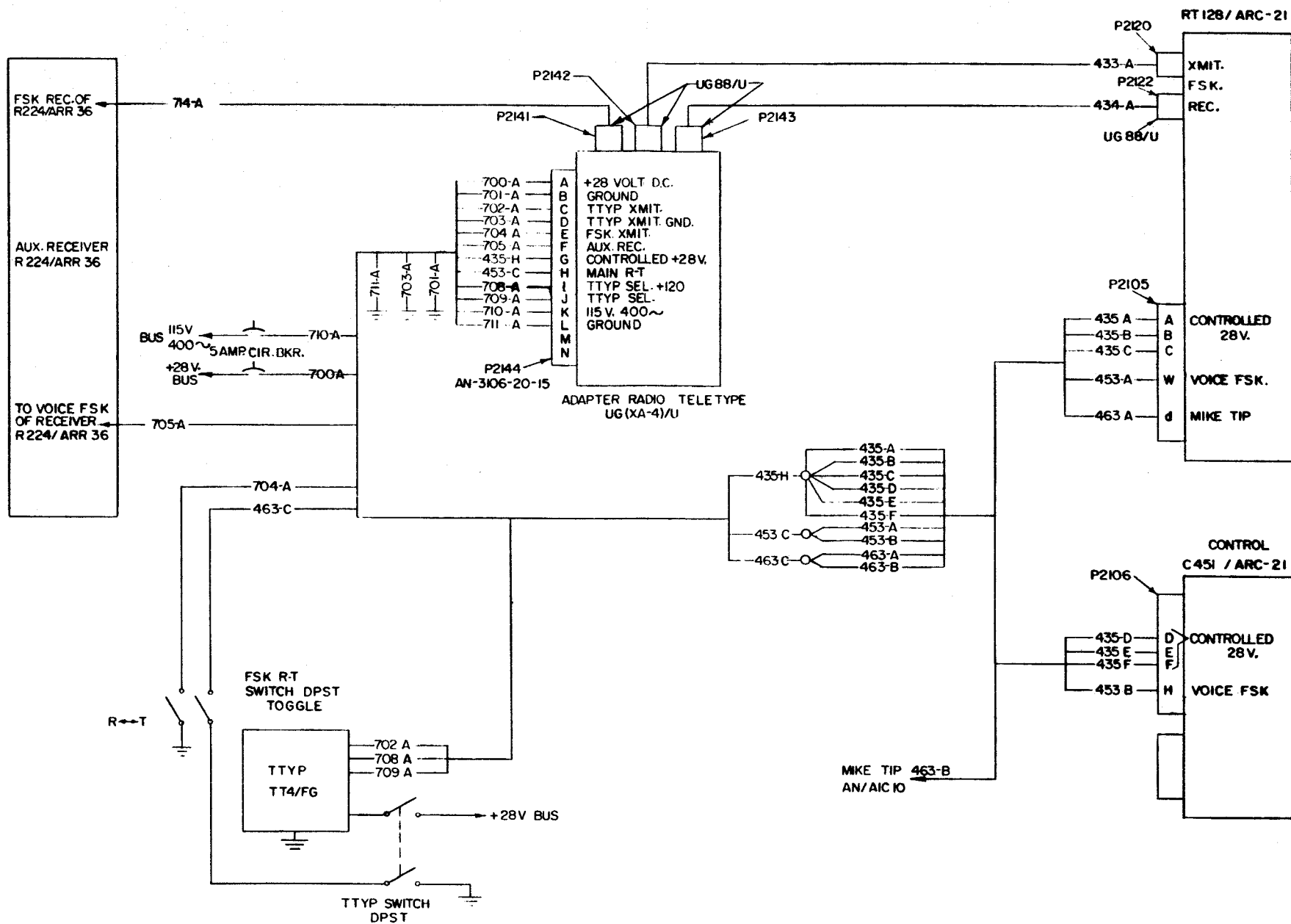

FIGURE 6. INSTALLATION CABLING DIAGRAM