

RESTRICTED

TRANSMITTER FUNDAMENTALS

COURSE 502



NAVAL RADIO MATERIEL TRAINING PROGRAM

RESTRICTED

TRANSMITTER FUNDAMENTALS

COURSE 502

NAVAL TRAINING SCHOOL
(RADIO MATERIEL)
TREASURE ISLAND
SAN FRANCISCO, CALIFORNIA

FEBRUARY 1945

TRANSMITTER FUNDAMENTALS

INTRODUCTION TO TRANSMITTERS

Most Navy communication must be accomplished without wires between ships or stations. In order to do this, radio transmitters are used to convert the intelligence into electromagnetic waves which can be transmitted through space.

The radio frequency spectrum is divided into the following standard frequency bands by the Federal Communications Commission:

DESIGNATION	FREQUENCIES	COMMUNICATION USES
Super high SHF	3,000 to 30,000 mc.)	
Ultra high UHF	300 to 3,000 mc.)	Short distance only.
Very high VHF	30 to 300 mc.)	
High HF	3 to 30 mc.)	Distance depends on time of day.
Medium MF	300 to 3,000 kc.)	Long distance at night only.
Low LF	30 to 300 kc.)	With high power, reliable long distance
Very low VLF	10 to 30 kc.)	day or night.

A complete radio transmitter may use amplifiers of several different types. The following table reviews the classes of operation and shows typical uses of each:

CLASS OF OPERATION	HOW BIASED	PLATE CURRENT FLOWS	GRID CURRENT FLOWS	TYPICAL USE OF AMPLIFIER IN TRANSMITTER OR RECEIVER
Class A	Between zero and cutoff, near the center of the straight portion of e_c vs i_b curve	360°	Class A ₁ 0°	Speech amplifier. RF, IF, and AF stages in receiver.
			Class A ₂ On signal peaks	Limiter in FM receiver. Audio oscillator.
Class AB	Between zero and cutoff, but usually more negative than Class A	Slightly less than 360°	Class AB ₁ 0°	Driver in modulator. RF oscillator in receiver.
			Class AB ₂ On signal peaks	
Class B	At cutoff, or projected cutoff	About 180°	Class B ₁ 0°	Driver in modulator. Linear RF amplifier for low-level modulation.
			Class B ₂ On signal peaks	
Class C	More negative than 1 1/2 times cutoff	Usually less than 150°	Class C ₁ 0°	Buffer.
			Class C ₂ On signal peaks	RF power amplifier in transmitter.

TRANSMITTER FUNDAMENTALS

The following figures illustrate the differences between the types of emission used in Navy communication transmitters:

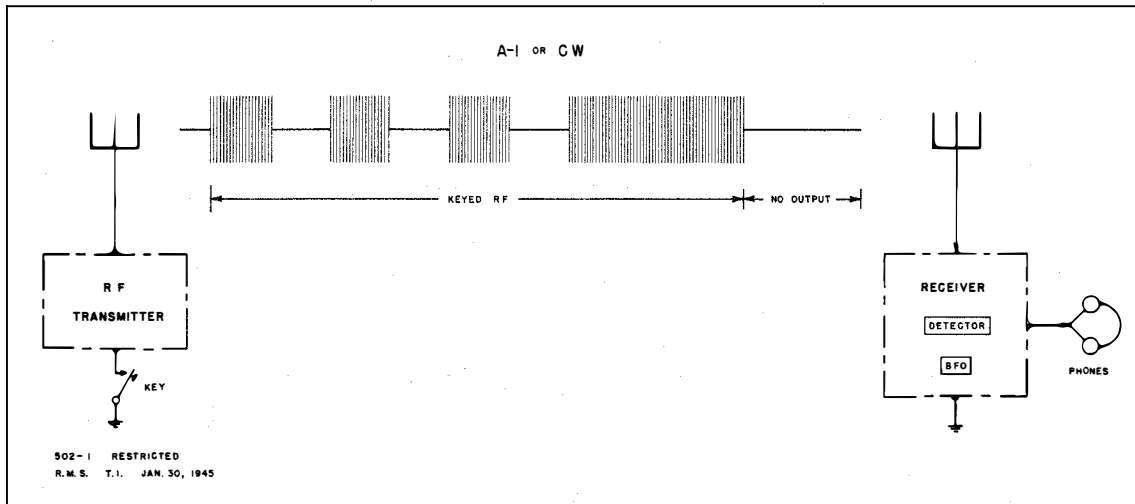

Fig. 1 Radiotelegraph system.

TYPE OF EMISSION: Radiotelegraphy. A-1 or CW.

USE: Long distance communication.

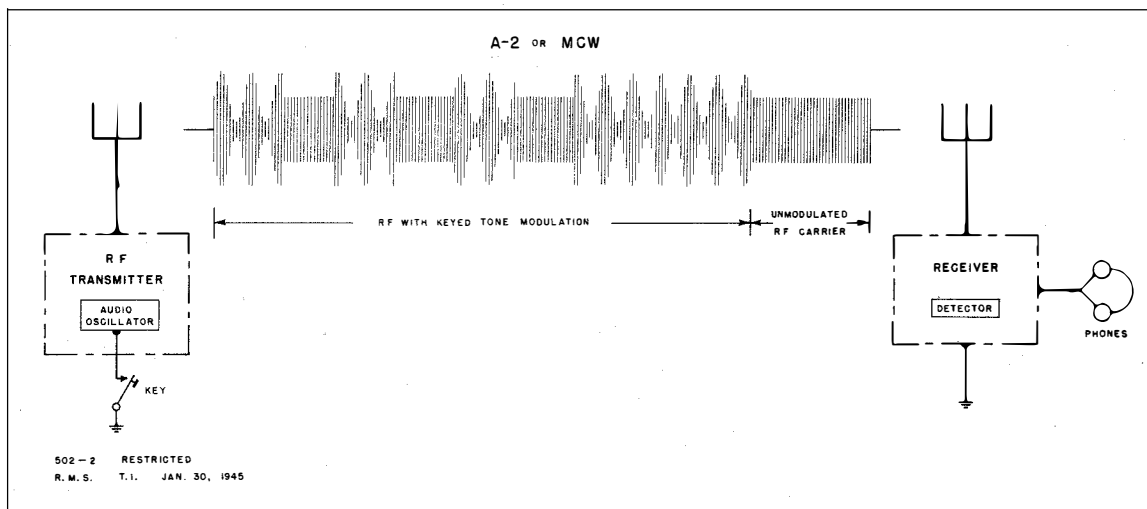

Fig. 2 Modulated radiotelegraphy system.

TYPE OF EMISSION: Amplitude modulated radiotelegraphy. A-2 or MCW.

USE: Jamming and emergency communication.

TYPES OF EMISSION

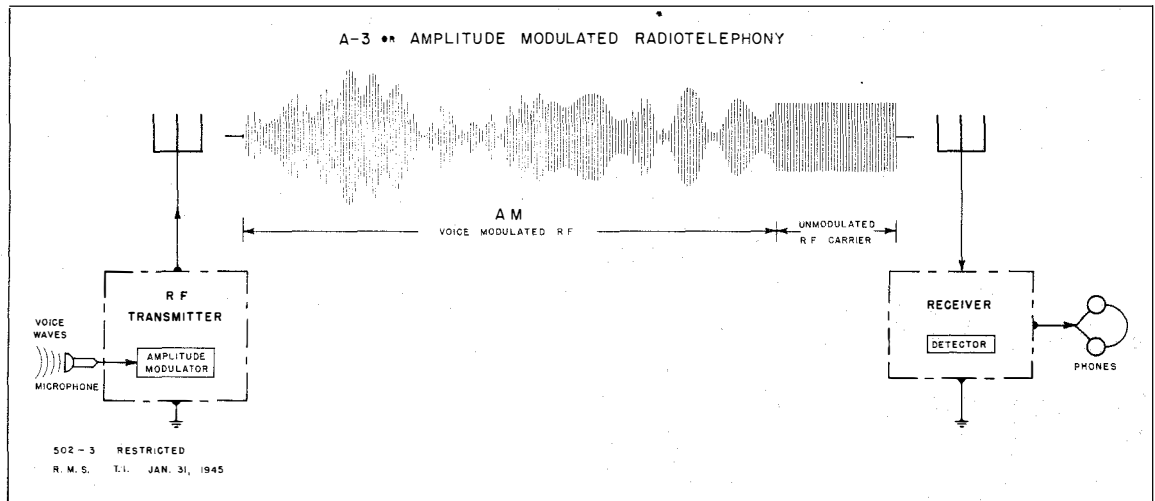

Fig. 3 Amplitude modulated radiotelephony system.

TYPE OF EMISSION: Amplitude modulated radiotelephony. A-3 or PHONE.

USE: Short distance communication.

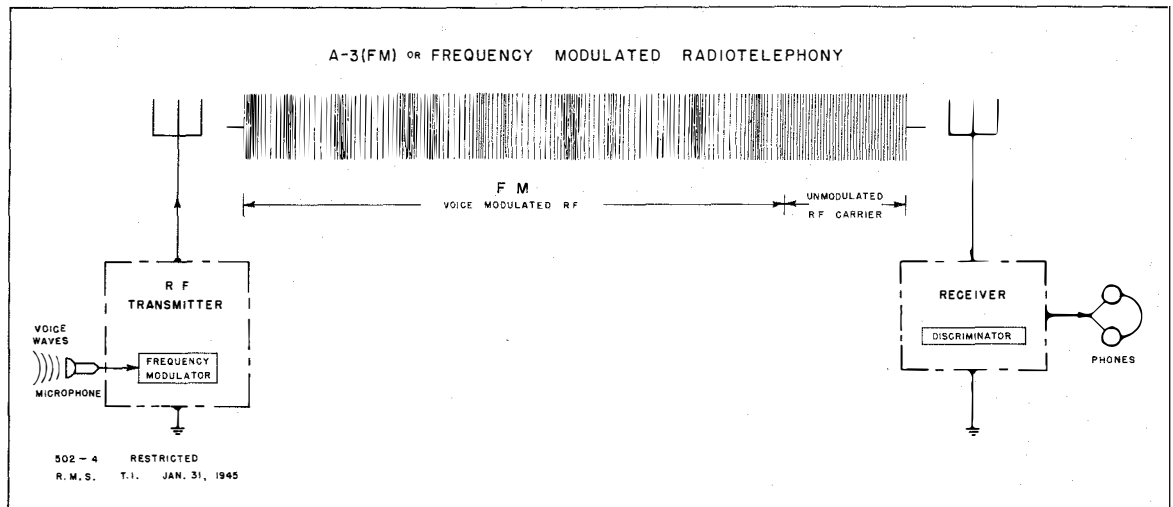

Fig. 4 Frequency modulated radiotelephony system.

TYPE OF EMISSION: Frequency modulated radiotelephony. A-3(FM).

USE: Portable communication equipment.

TRANSMITTER FUNDAMENTALS

DEVELOPMENT OF A BASIC RADIO TRANSMITTER

PURPOSE: A communication type transmitter must provide an RF signal with good frequency stability, and with sufficient power to be radiated from an antenna to a distant receiver.

POWER OSCILLATOR TYPE TRANSMITTER

The oscillator tank is directly coupled to the antenna.

This transmitter is very simple, but has poor frequency stability because changes in the capacitance C_A between the antenna and ground detune the oscillator tank circuit.

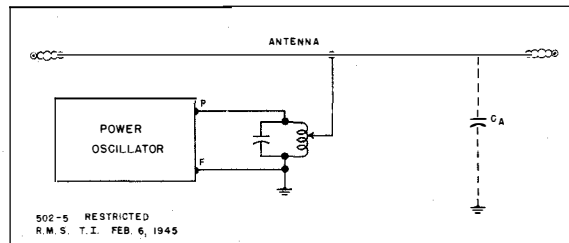

Fig. 5 Power oscillator transmitter.

MASTER OSCILLATOR POWER AMPLIFIER TYPE TRANSMITTER

A power amplifier is connected between the oscillator and the antenna.

Loose coupling between the two stages improves frequency stability.

The power amplifier increases the power output of the transmitter.

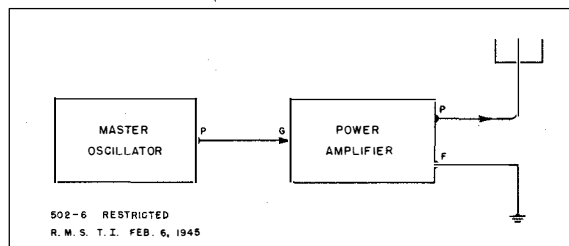

Fig. 6 MOPA transmitter.

THREE-STAGE TYPE TRANSMITTER

An intermediate amplifier is connected between the master oscillator and the final power amplifier, and may serve as a frequency multiplier, a buffer, a power amplifier, or a combination of all three.

The advantages of the three-stage transmitter are:

- (1) Good frequency stability.
- (2) Wide frequency range.
- (3) High power output.

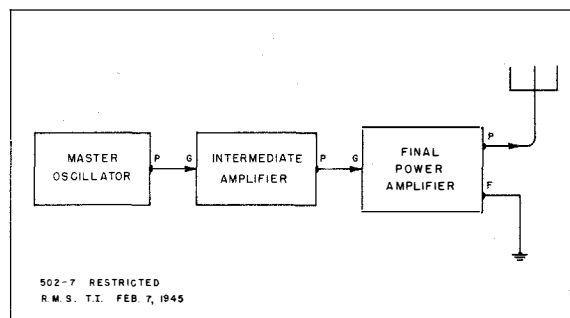

Fig. 7 Three-stage transmitter.

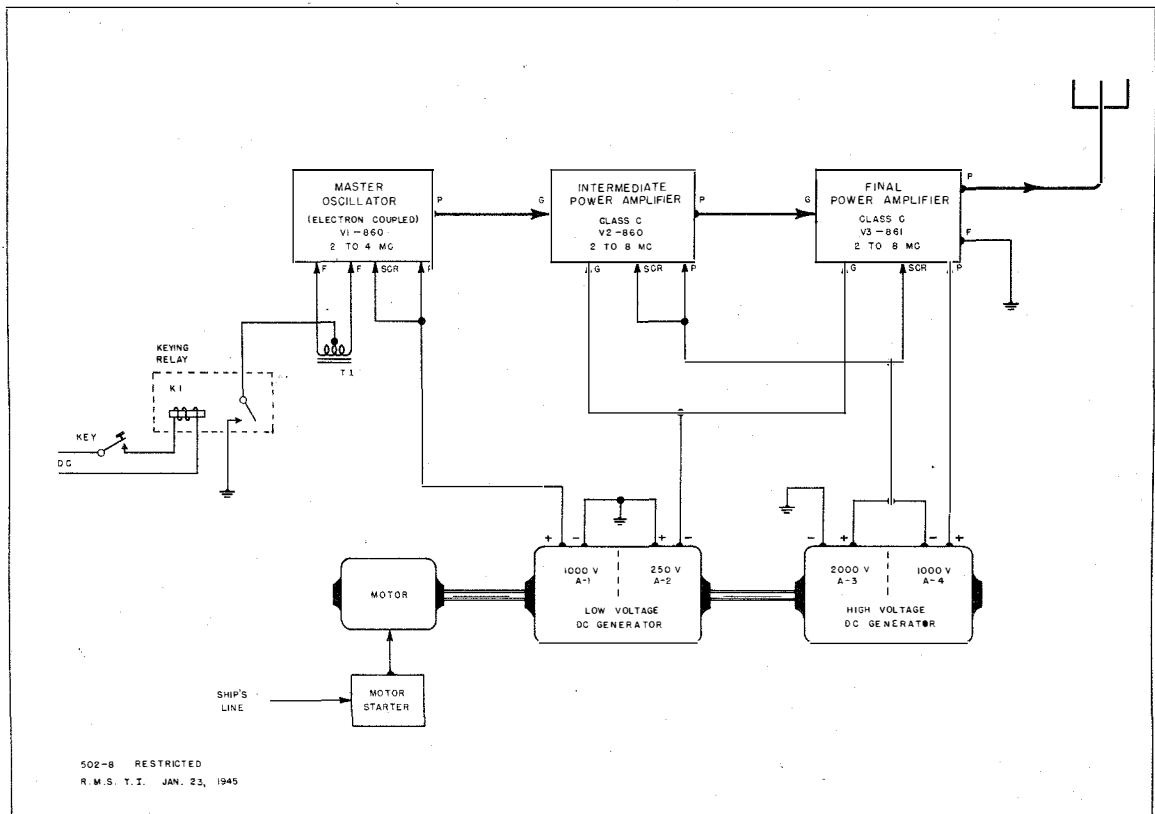

Fig. 8 A basic transmitter and power supply

1. **PURPOSE:** To generate, amplify, and transmit an RF signal.
2. **GENERAL CIRCUIT CONDITIONS; :**
 - (a) The primary of the filament transformer is supplied from:
 - (1) The ship's line if line is AC.
 - (2) Slip rings on the motor if ship's line is DC.
 - (b) The master oscillator is of the electron coupled type for good frequency stability over a wide tuning range.
 - (c) The oscillator and amplifier stages all are operated Class C for good efficiency.
3. **OPERATION:**
 - (a) The master oscillator (MO) generates the RF signal.
 - (b) The intermediate power amplifier (IPA) isolates the master oscillator from the final power amplifier to improve frequency stability, and also doubles the frequency on the upper half of the tuning range.
 - (c) The final power amplifier (PA) delivers 500 watts of RF power output to the antenna.
 - (d) Keying is accomplished in the master oscillator stage. While the key is up, the amplifier tubes are protected by fixed bias.
4. **RESULTS:** This transmitter can produce a 500-watt CW signal at any frequency from 2 to 8 mc.

TRANSMITTER FUNDAMENTALS

POWER SUPPLY

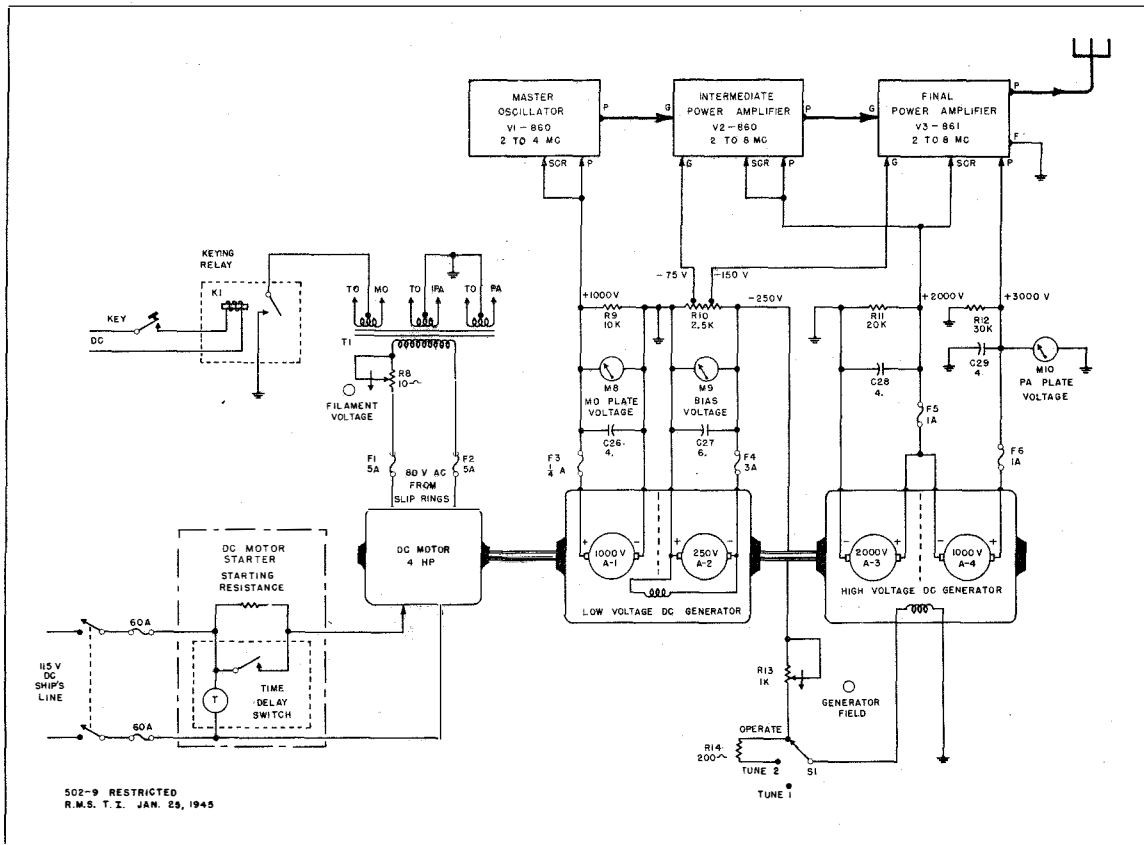

Fig. 9 Power supply of basic transmitter

1. **PURPOSE:** To provide filament, bias, screen and plate voltages.
2. **OPERATION OF MOTOR:** The 4-horsepower DC motor drives the two DC generators, and supplies AC to the filament transformer (T-1) from slip rings connected to the motor armature.
3. **OPERATION OF LOW VOLTAGE DC GENERATOR:**
 - (a) A 1000-volt armature (A-1) and a 250-volt armature (A-2) both are wound on the same core.
 - (b) The shunt field is self-excited from the 250-volt DC output.
4. **OPERATION OF HIGH VOLTAGE DC GENERATOR:**
 - (a) A 2000-volt armature (A-3) and a 1000-volt armature (A-4) both are wound on the same core.
 - (b) The shunt field is excited from the 250-volt DC output of the low voltage generator.
 - (c) The high voltage DC outputs are adjusted by changing the field excitation, either with GENERATOR FIELD control (R-13) or with TUNE-OPERATE switch (S-1) and R-14.

MASTER OSCILLATOR

7

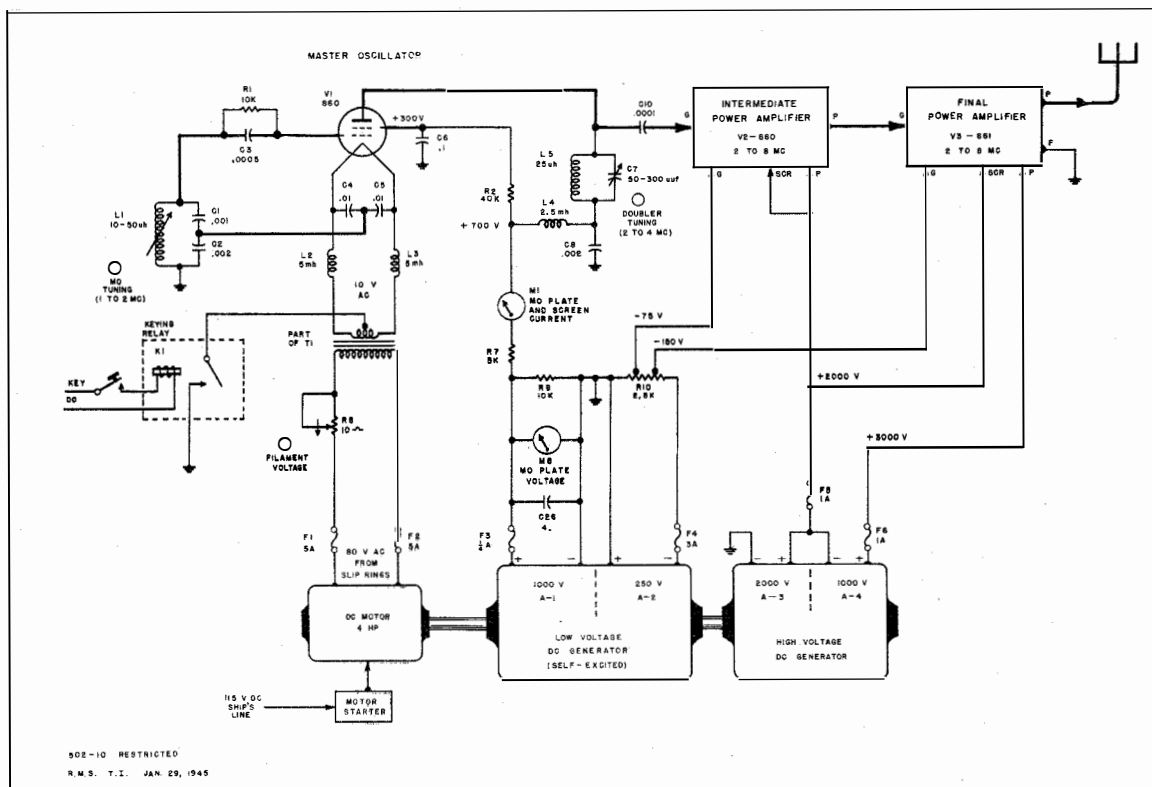

Fig. 10 Master oscillator of basic transmitter.

1. **PURPOSE:** To generate a stable RF signal that can be tuned over a wide range in frequency.
2. **GENERAL CIRCUIT CONDITIONS:** An 860 tube in an electron-coupled circuit.
3. **OPERATION OF GRID-SCREEN GRID CIRCUIT:**
 - (a) Frequency of oscillation is determined by the grid-screen grid tank circuit (L-1, C-1 and C-2), and ranges from 1 to 2 mc.
 - (b) Grid leak bias is developed across R-1 and C-3.
 - (c) The filament is maintained above RF ground by L-2 and L-3.
 - (d) C-4 and C-5 provide an RF return path to the filament.
 - (e) T-1 supplies 10 volts AC for the filament.
 - (f) R-2 drops the screen supply to 300 volts.
 - (g) C-6 grounds the screen for RF.
 - (h) RF oscillations are electron-coupled to the plate circuit.
4. **OPERATION OF THE DOUBLER CIRCUIT:**
 - (a) The plate tank circuit (L-5 and C-7) doubles the frequency to improve the isolation between grid and plate circuits.
 - (b) C-8 grounds one side of the plate tank circuit for RF.
 - (c) M-1 measures DC plate and screen current.
 - (d) R-7 drops the plate supply to 700 volts.
 - (e) The RF choke L-4 connects DC plate voltage to V-1, and keeps RF out of the power supply.
 - (f) The RF output is coupled from the MO to the next stage through C-10.

TRANSMITTER FUNDAMENTALS

INTERMEDIATE POWER AMPLIFIER

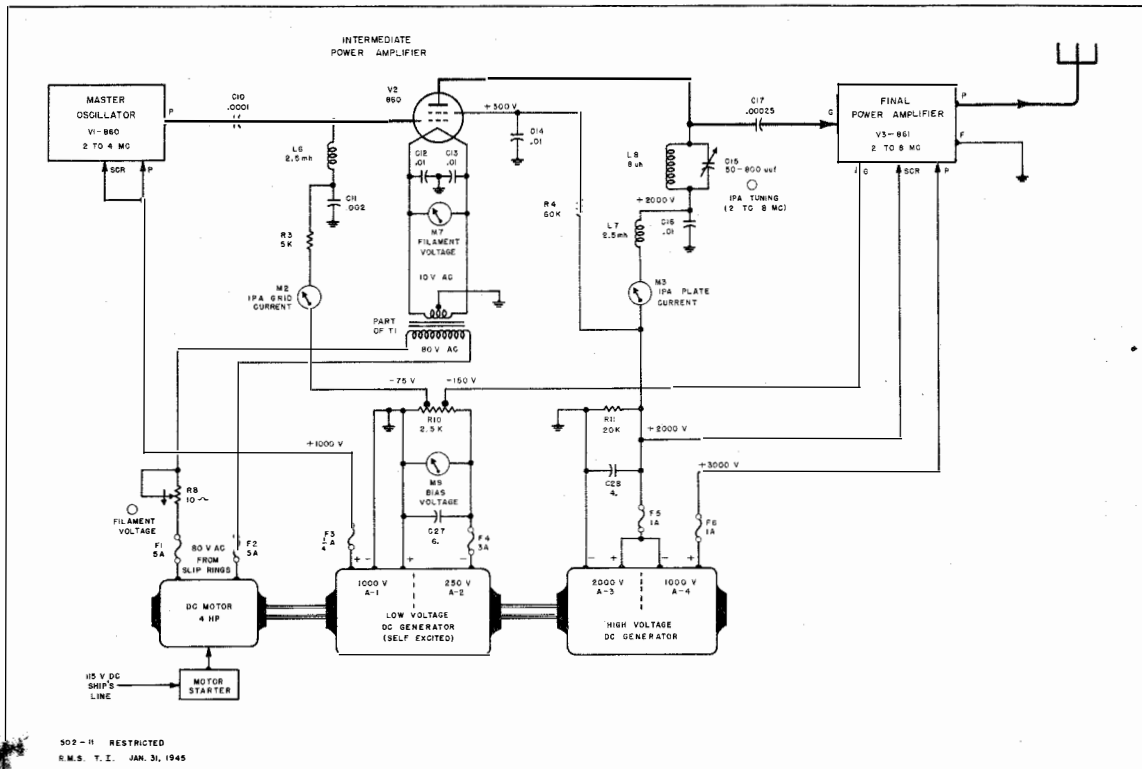

Fig. 11 Intermediate power amplifier of basic transmitter.

1. **PURPOSE:** To increase the excitation for the final power amplifier, without impairing the frequency stability of the master oscillator. Also to increase the tuning range if desired.
2. **GENERAL CIRCUIT CONDITIONS:** An 860 tube operated Class C.
3. **OPERATION:**
 - (a) The IPA may either double or operate straight through.
 - (b) C-10 couples the output of the MO to the IPA.
 - (c) C-12 and C-13 provide an RF return to the filament.
 - (d) Grid leak bias across R-3 adds to the fixed bias from the generator.
 - (e) L-6 and C-11 prevent loss of RF through the DC bias supply.
 - (f) M-2 measures DC grid current.
 - (g) T-1 supplies 10 volts AC for the filament.
 - (h) M-7 measures filament voltage.
 - (i) R-4 drops the screen supply to 300 volts.
 - (j) C-14 grounds the screen for RF.
 - (k) The plate tank circuit (L-8 and C-15) tunes from 2 to 8 mc.
 - (l) M-3 measures DC plate current.
 - (m) C-16 grounds one side of the plate tank circuit for RF.
 - (n) L-7 prevents RF from reaching the high voltage DC power supply.
 - (o) The RF output of the IPA is coupled to the next stage through C-17.

FINAL POWER AMPLIFIER

9

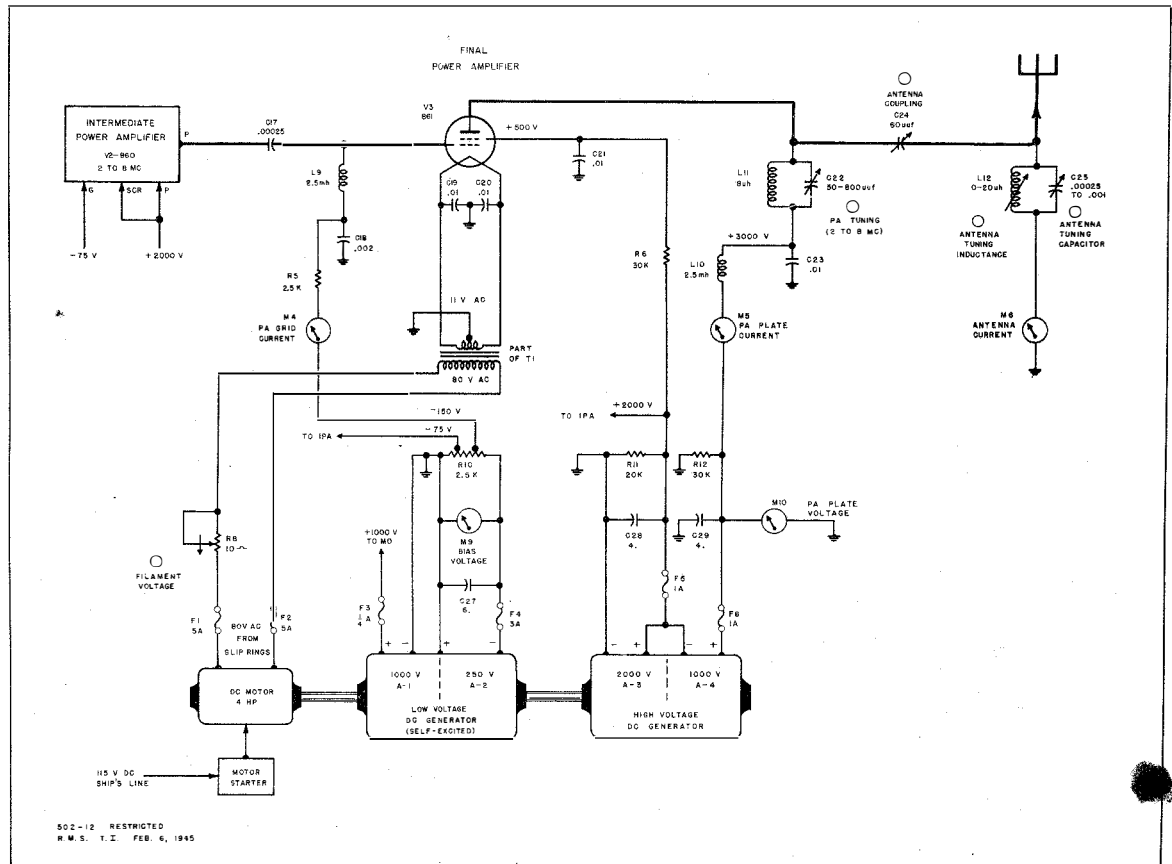

Fig. 12 Final power amplifier of basic transmitter.

1. **PURPOSE:** To increase the RF power output of the transmitter to 500 watts.
2. **GENERAL CIRCUIT CONDITIONS:** An 861 tube operated Class C.
3. **OPERATION:**
 - (a) The final power amplifier (PA) always operates straight through for good efficiency.
 - (b) C-17 couples the RF output from the IPA to the final PA.
 - (c) C-19 and C-20 provide an RF return path to the filament.
 - (d) Grid leak bias across R-5 adds to the fixed bias from the generator.
 - (e) L-9 and C-18 prevent loss of RF through the DC bias supply.
 - (f) M-4 measures DC grid current.
 - (g) T-1 supplies 11 volts AC for the filament.
 - (h) R-6 drops the screen supply to 500 volts.
 - (i) C-21 grounds the screen for RF.
 - (j) The plate tank circuit (L-11 and C-22) tunes from 2 to 8 mc.
 - (k) The RF choke L-10 keeps RF out of the high voltage DC power supply.
 - (l) M-5 measures DC plate current.
 - (m) C-24 couples the RF output from the PA to the antenna.
 - (n) L-12 and C-25 tune the antenna circuit to resonance.
 - (o) M-6 measures the RF antenna current.

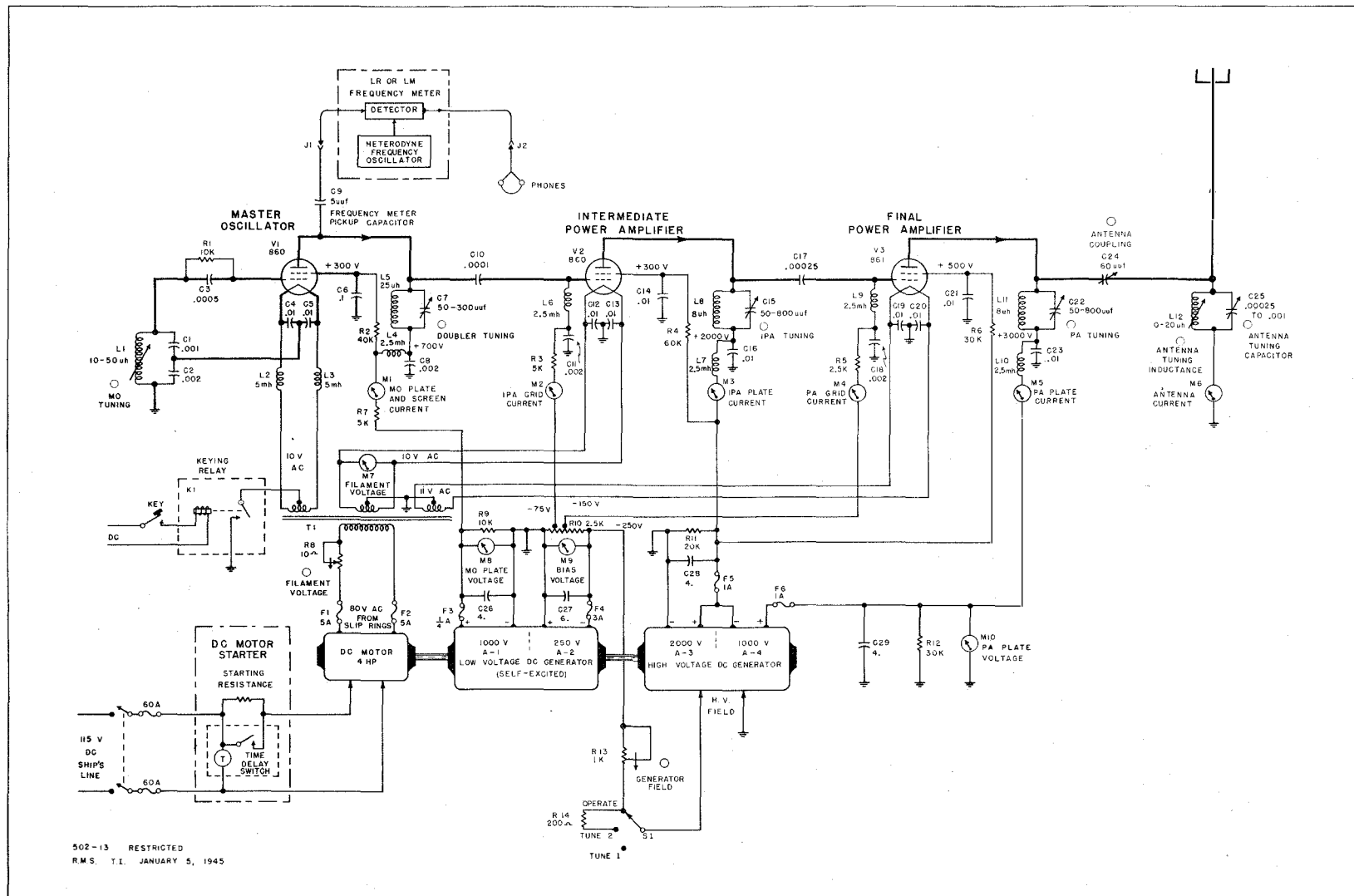

Fig. 13 Basic transmitter, schematic diagram, showing frequency meter connection.

STARTING THE TRANSMITTER

1. Start the motor-generator.
2. Adjust **FILAMENT VOLTAGE** (R-8) for 10 v. on the filament voltmeter (M-7).
3. Place the tune-operate switch (S-1) in **OPERATE**. *Do not close the key!*
4. Adjust **GENERATOR FIELD** (R-13) for 3,000 v. on the plate voltmeter (M-10).
5. Place the tune-operate switch (S-1) in **TUNE 1**.

CONNECTING THE FREQUENCY METER

6. Connect the frequency meter (LR or LM) to the MO plate circuit.
7. Set the LR or LM to the exact frequency required at the output of the MO. If necessary, divide the transmitter output frequency by 2 until it is within the 2 to 4 mc. range of the MO.
8. Set all transmitter tuning controls approximately to the correct frequency with the aid of tuning charts and curves in the instruction book. Set **ANTENNA COUPLING** (C-24) to *minimum*.

TUNING THE MASTER OSCILLATOR

9. Hold the test key closed *only during tuning adjustments*.
10. Adjust **MP TUNING** (L-1) for zero beat in the output of the frequency meter.

11. Adjust **DOUBLER TUNING** (C-7) for a *peak* in IPA grid current (M-2).

TUNING THE INTERMEDIATE POWER AMPLIFIER

12. Place the tune-operate switch (S-1) in **TUNE 2**.
13. Adjust **IPA TUNING** (C-15) for a *dip* in IPA plate current (M-3), or for a *peak* in PA grid current (M-4). *Watch the PA plate current* (M-5), and if it exceeds 200 ma., stop tuning the IPA and adjust **PA TUNING** (C-22) for a *dip* in PA plate current (M-5). Finish tuning the IPA.

TUNING THE FINAL POWER AMPLIFIER

14. Adjust **PA TUNING** (C-22) for a *dip* in PA plate current (M-5).

TUNING THE ANTENNA CIRCUIT

15. Increase **ANTENNA COUPLING** (C-24) for about a 10% *rise* in PA plate current (M-5).
16. Adjust **ANTENNA TUNING INDUCTANCE** (L-12, coarse) and **ANTENNA TUNING CAPACITOR** (C-25, vernier) for a *peak* in PA plate current (M-5).
17. Readjust **PA TUNING** (C-22) for a *dip* in PA plate current (M-5).
18. Repeat steps 15, 16 and 17 as many times as necessary to obtain about 200 ma. (2/3 maximum) PA plate current (M-5).
19. Place the tune-operate switch (S-1) in **OPERATE**, and repeat steps 15, 16 and 17 to obtain not more than 300 ma. of PA plate current (M-5) for full power output.

TRANSMITTER FUNDAMENTALS

KEYING RADIOTELEGRAPH TRANSMITTERS

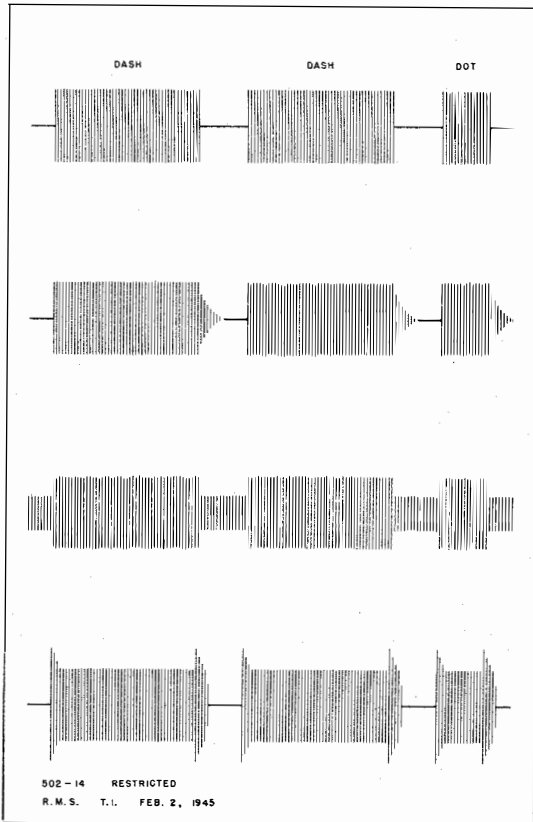

NORMAL KEYING: Clear-cut and distinct.

KEYING TAILS: A gradual reduction in RF output after the key is opened, instead of the desired abrupt drop to zero.

BACKWAVE: Incomplete blocking of one or more of the transmitter stages while the key is up.

KEY CLICKS: Abnormally high power applied to the antenna at the instant the key is first closed, and again when the key is opened. Key clicks are often caused by arcing at the keying contacts.

Fig. 14 Keying waveforms.

1. **PURPOSE:** To control the RF output from a transmitter so intelligence in the form of dots and dashes will be transmitted.
2. **TRANSMITTER KEYING REQUIREMENTS:**
 - (a) The keying must be positive. That is, the signal at the distant receiver must be clear-cut and distinct. There should be no tails, backwave or key clicks.
 - (b) The transmitter should have good frequency stability when keyed so the signal will not be 'bloopy' or 'chirpy'.
 - (c) The keying system must be capable of operating at the required speed. Hand keying seldom exceeds 20 words per minute, but automatic keying heads operate up to several hundred words per minute.
 - (1) Up to 100 words per minute, the mechanical action of a keying relay is satisfactory.
 - (2) Above 100 words per minute, vacuum tube keying systems should be used.
 - (d) The transmitter should consume as little power as possible while the key is up.
 - (e) All stages that are not keyed must have protective fixed bias while the key is up.

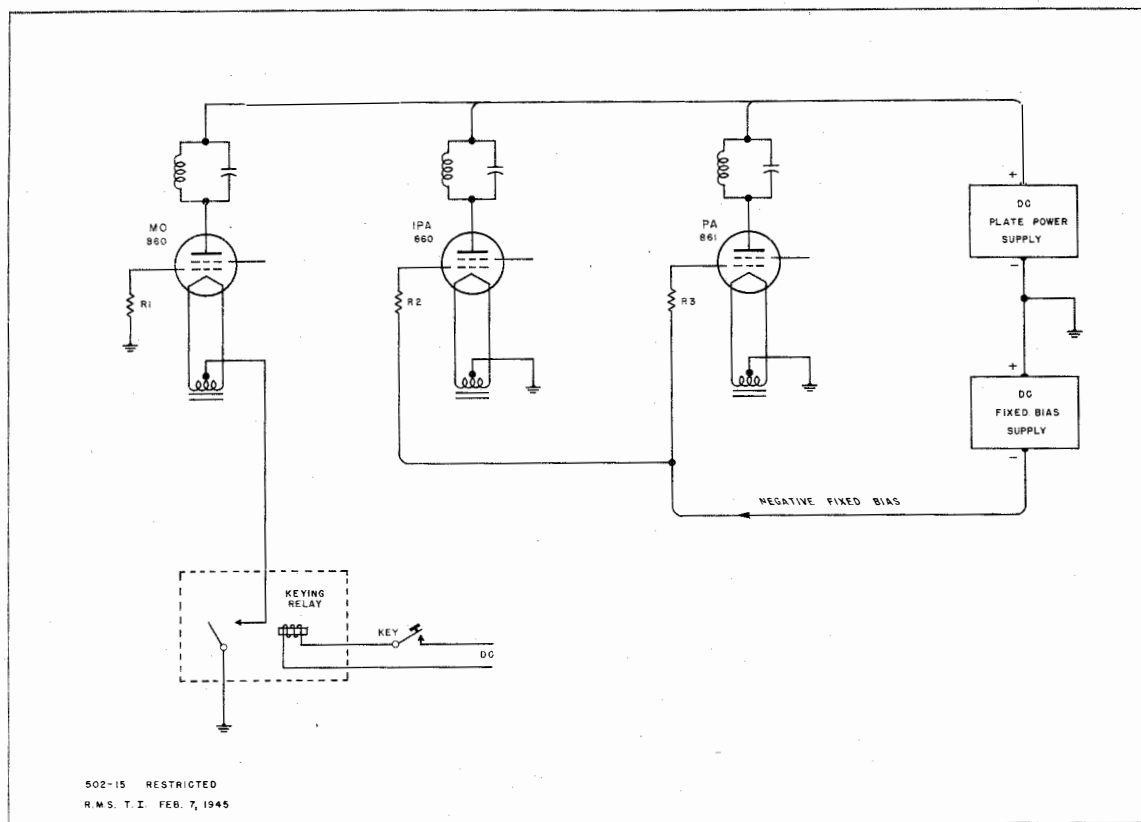

Fig. 15 Center tap keying circuit similar to that of TBK transmitters.

1. **GENERAL CIRCUIT CONDITIONS:** The amplifier stages are biased at or beyond cutoff without RF excitation.
2. **OPERATION:**
 - (a) When the key is closed the keying relay is energized.
 - (b) The keying relay contacts close, completing a DC path from the plate power supply through the center tap on the filament transformer to the filament of the master oscillator.
 - (c) Oscillations start in the MO, and are amplified by the IPA and PA.
 - (d) When the key is opened the keying relay is de-energized.
 - (e) The relay contacts open, breaking the DC path to the master oscillator filament center tap.
 - (f) Oscillations stop in the MO, thus removing RF excitation from the IPA and PA.
 - (g) Fixed bias on the IPA and PA reduces plate current and RF output to zero.
3. **RESULTS:**
 - (a) Positive keying because the master oscillator is keyed.
 - (b) Satisfactory keying at speeds up to 100 words per minute.
 - (c) Key clicks will occur unless a key click filter is used. Typical filters of this type are explained in Course 503-504.

TRANSMITTER FUNDAMENTALS

BLOCKED GRID KEYING

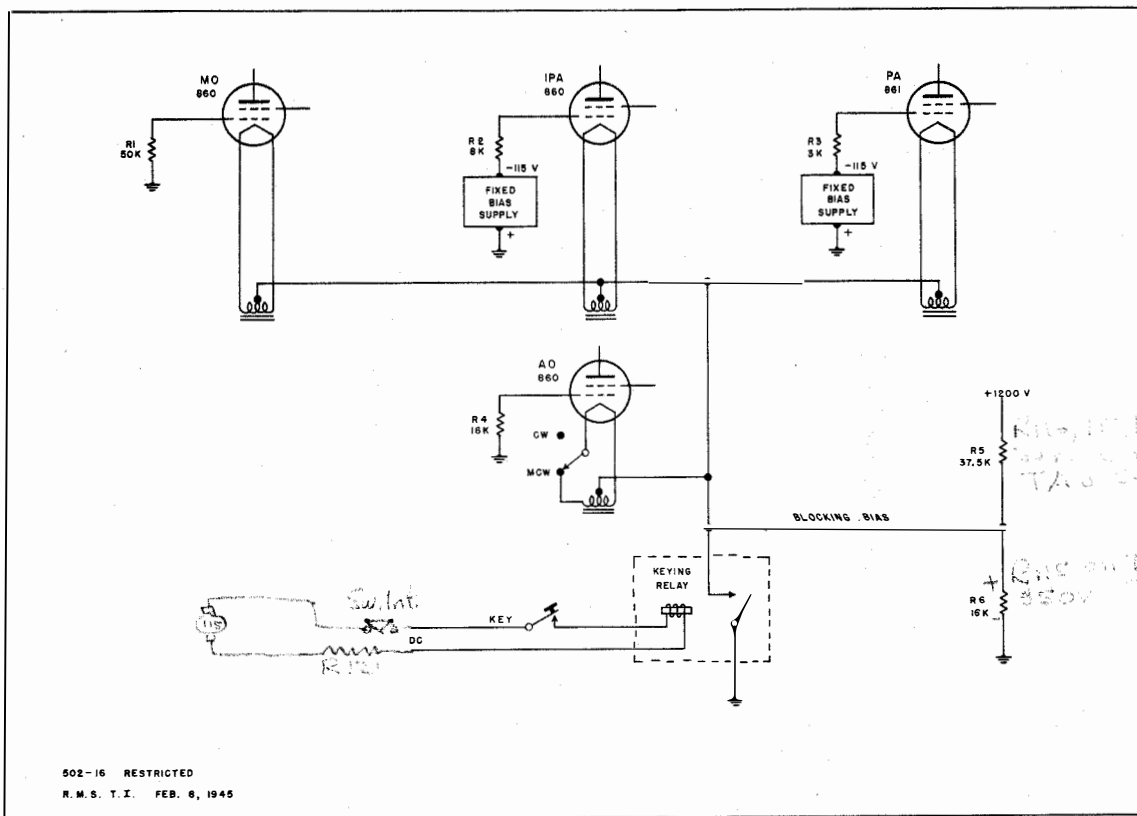

Fig. 16 Blocked grid keying circuit similar to that of TAJ transmitters.

1. GENERAL CIRCUIT CONDITIONS:

- (a) The amplifier stages are biased beyond cutoff without RF excitation.
- (b) Additional bias across R-6 is high enough to block all stages when the key is open.

2. OPERATION:

- (a) When the key is closed, the keying relay is energized.
- (b) The relay contacts short out the blocking bias across R-6, grounding the common filament return of all stages.
- (c) RF oscillations start in the MO and are amplified by the IPA and PA.
- (d) If the emission selector switch is in MCW position, AF oscillations start in the audio oscillator (AO), tone modulating the RF.
- (e) When the key is opened, the keying relay is de-energized.
- (f) With the relay contacts open, bleeder current develops blocking bias across R-6, raising all filaments to a high positive potential with respect to the grids.
- (g) This makes the grids very negative with respect to the filaments, stopping the output from all stages.

3. RESULTS: Positive keying because all stages are keyed simultaneously. Otherwise the results are the same as in center tap keying.

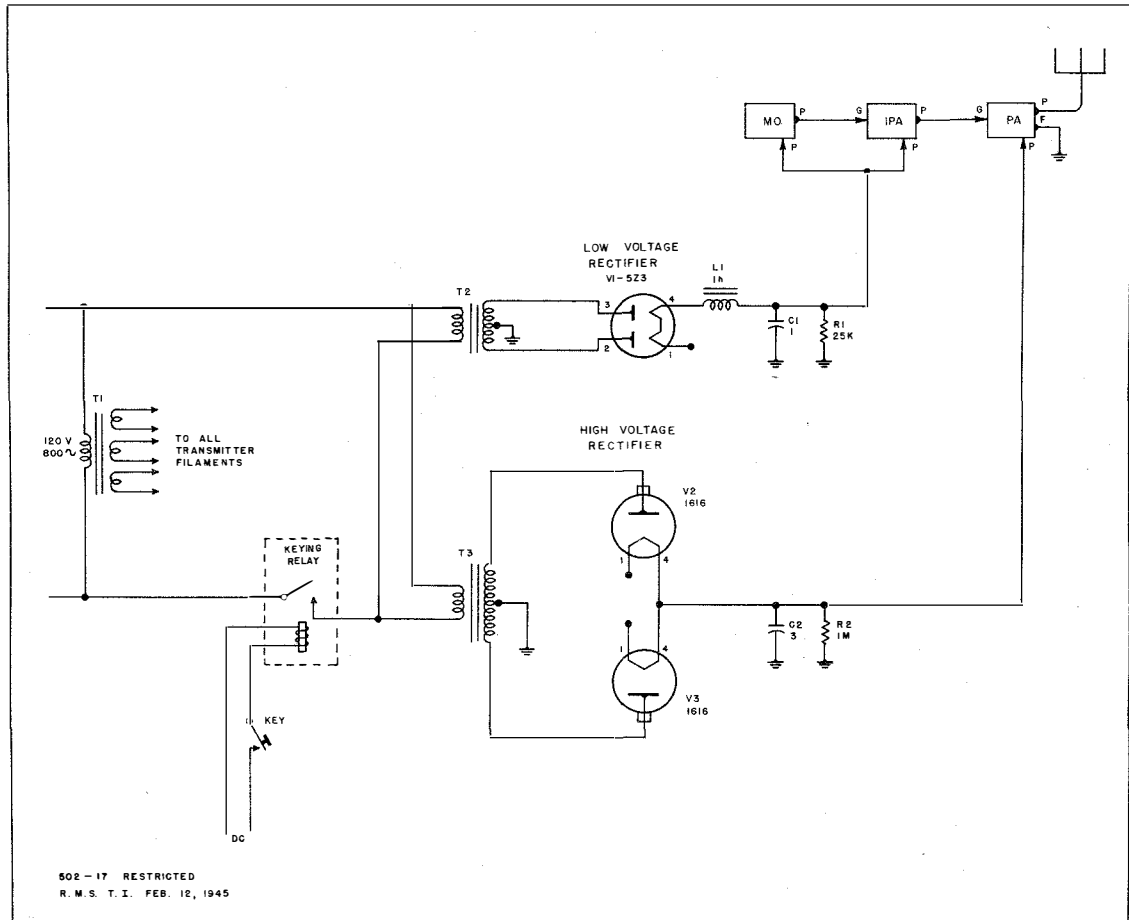

Fig. 17 Plate transformer primary keying similar to that in TBW transmitters.

1. GENERAL CIRCUIT CONDITIONS:

- (a) High frequency (800-cycle) AC power supply minimizes the transformer inductance and filter capacity necessary.
- (b) The filament transformer is energized continuously.

2. OPERATION:

- (a) When the key is closed, the keying relay contacts connect the primaries of both rectifier plate transformers to the 800-cycle line.
- (b) The power supply rectifiers deliver DC to the plates of the transmitter tubes, causing the transmitter to operate.
- (c) When the key is open, the keying relay contacts disconnect the primaries of the power supply rectifiers.

3. RESULTS:

- (a) Satisfactory keying at hand speeds in portable and aircraft equipment
- (b) The circuit is not adaptable to high speed keying because of the smoothing action of the power transformers and filter circuits.
- (c) Cannot be used on high powered transmitters because of the high primary currents.

TRANSMITTER FUNDAMENTALS

GRID LEAK KEYING

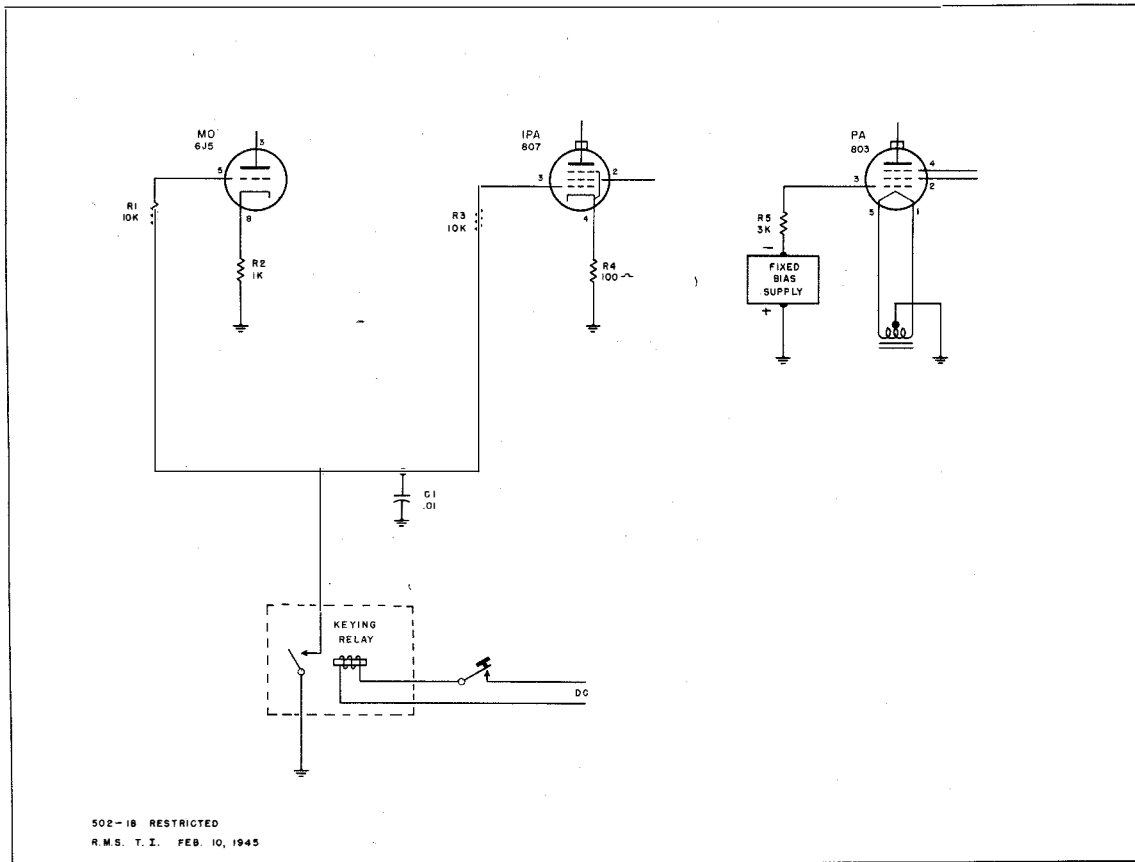

Fig. 18 Grid leak keying similar to that in TBW transmitters.

1. GENERAL CIRCUIT CONDITIONS:

- (a) Cutoff fixed bias on the PA stage.
- (b) Self-bias on the keyed stages for protection of tubes if RF excitation fails. (Fixed bias can not be used on these stages).

2. OPERATION:

- (a) When the key is closed, the keying relay contacts connect the grid return of the MO and IPA to ground.
- (b) Oscillations start in the MO and are amplified by the IPA and PA.
- (c) When the key is open, the keying relay contacts open, and grid current charges C-1 negative on the grid side.
- (d) The MO is blocked and oscillations stop.
- (e) The transmitter will stay off until the charge on C-1 leaks off through stray leakage paths.

3. RESULTS: This system of keying is satisfactory only when used in conjunction with some other system such as primary keying, because once the charge on C-1 leaks off, the RF carrier comes on again automatically unless power is removed from the tubes.

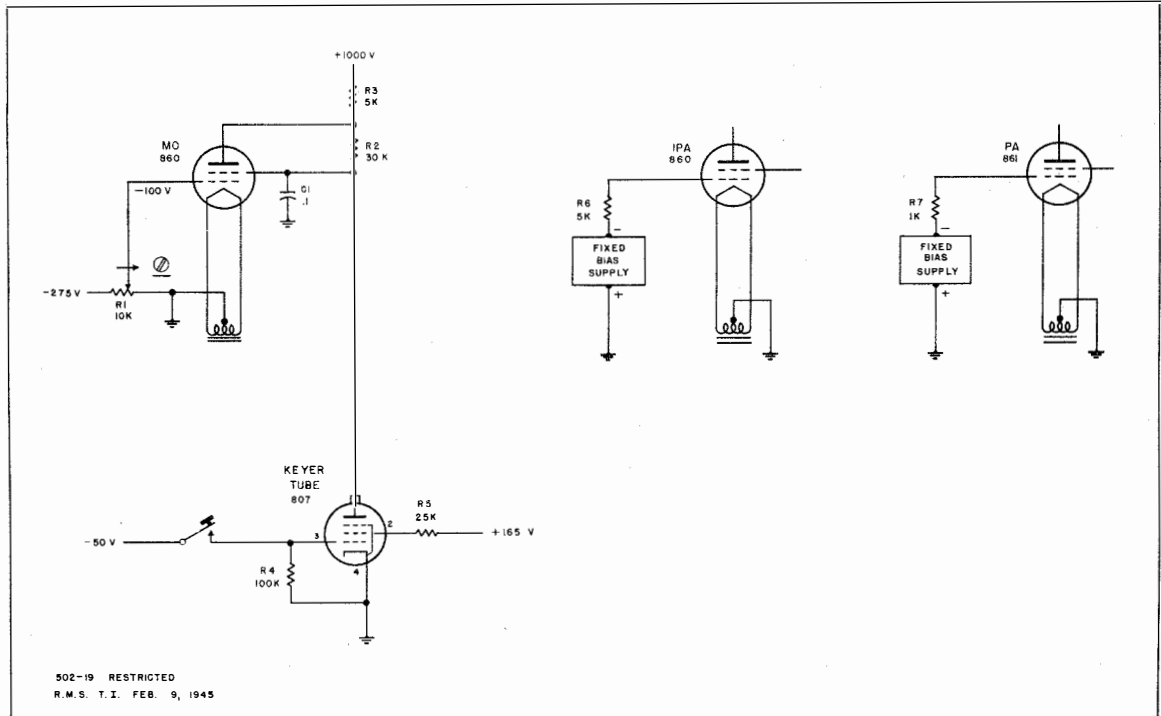

Fig. 19 Vacuum tube keying similar to that in TBK transmitters.

1. GENERAL CIRCUIT CONDITIONS:

- (a) Cutoff fixed bias on the IPA and PA stages.
- (b) Keyer tube normally conducting with zero bias (key open).
- (c) MO circuit adjusted so that low screen voltage stops oscillations.
- (d) Either a manual key or an automatic keying head may be connected directly in the keyer tube grid circuit without a relay.

2. OPERATION:

- (a) When the key is up, plate current of the zero biased keyer tube flows through R-2, dropping the MO screen voltage to a low value and thus preventing oscillations.
- (b) The keyer tube continues to conduct plate current even though its plate voltage is low.
- (c) When the key is closed, a negative voltage applied to the grid of the keyer tube stops its plate current.
- (d) The MO screen voltage rises to the normal value because no keyer tube plate current flows through R-2.
- (e) Oscillations start in the MO and are amplified by the IPA and PA.

3. RESULTS:

- (a) The instantaneous response of a vacuum tube keyer permits keying speeds up to 500 words per minute by the use of a keying head.
- (b) No current flow is broken by the keying contacts, thus reducing key clicks and preventing the keying contacts from burning.
- (c) Backwave will result if the keyer tube plate current does not drop the MO screen voltage low enough to completely block oscillations.

TRANSMITTER FUNDAMENTALS

MODULATION OF RF TRANSMITTERS

Sound waves, code or other impulses which can not be transmitted directly through space for long distances are combined with an RF signal in the transmitter. The entire combination is radiated as an electromagnetic wave from the transmitting antenna. The modulation impulses are separated from the RF 'Carrier' wave by the demodulator in the receiver, and the original intelligence is reproduced.

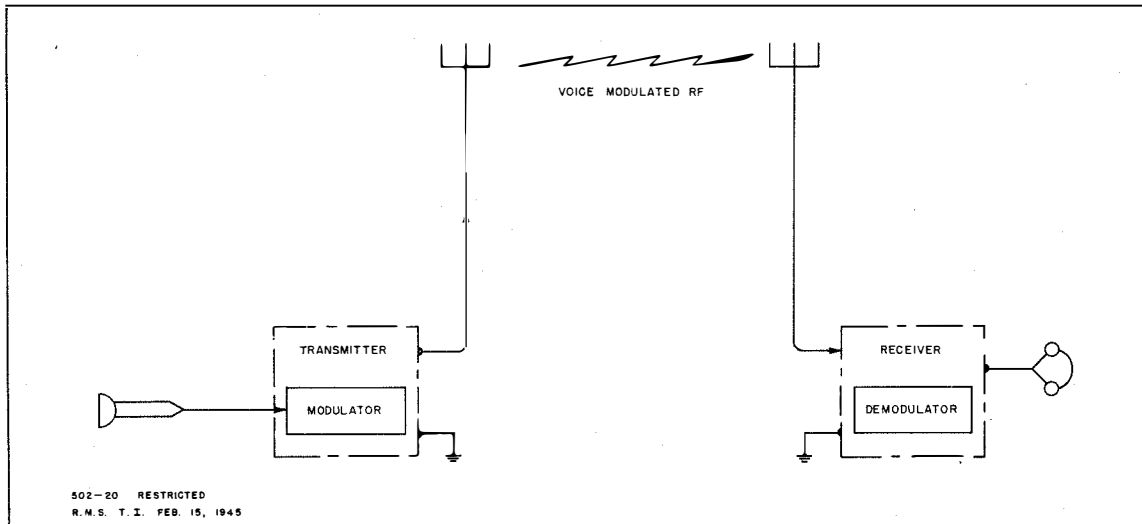

Fig. 20 Basic system of communication by voice modulated RF.

1. **PURPOSE OF MODULATION:** To vary the RF output of a transmitter according to intelligence to be transmitted.
2. **GENERAL CONDITIONS:** Voice modulation is indicated in Fig. 20, but the modulation also may be code, music or picture impulses.
3. **OPERATION:**
 - (a) The microphone converts sound waves into electrical impulses.
 - (b) The modulator amplifies the audio frequencies and feeds them to the RF transmitter.
 - (c) The RF output of the transmitter varies according to the sound waves, causing a modulated RF wave to appear at the antenna.
 - (d) The modulated RF wave is radiated from the transmitter antenna to a distant receiver, becoming weaker with increased distance.
 - (e) The signal is picked up by the receiving antenna.
 - (f) The receiver amplifies the weak RF signal, and demodulates it to reproduce the audio frequencies.
 - (g) The AF signal is further amplified and fed to the phones.
 - (h) The phones convert the AF electrical variations to sound waves that are practically identical to those which actuated the microphone at the transmitting station.
4. **RESULTS:** Intelligence is transmitted through space without wires between transmitter and receiver.

1. **AMPLITUDE MODULATION:** The intelligence to be transmitted causes the *amplitude* of the radiated wave to vary. If the envelope variations of the modulated wave exactly reproduce the original variations in sound pressure, light intensity or code characters, these variations are transmitted without distortion.

AM is used throughout the radio spectrum, but principally below the VHF band.

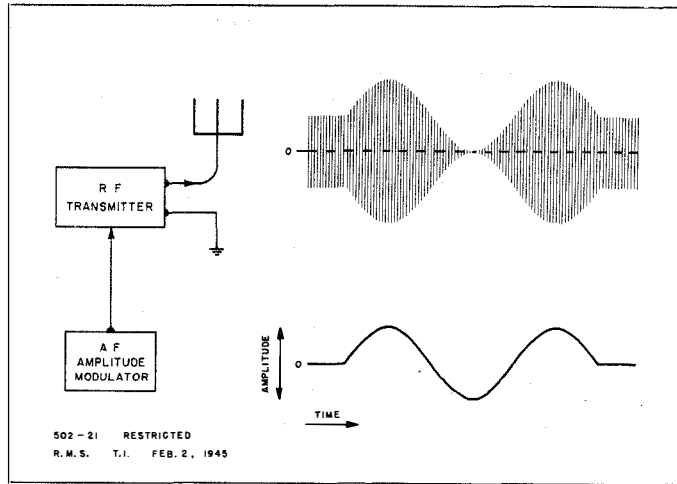

Fig. 21 Amplitude modulation.

2. **FREQUENCY MODULATION:** The intelligence to be transmitted causes not the amplitude but the *frequency* of the radiated wave to vary in accordance with the intelligence to be transmitted.

FM is used principally in the VHF band.

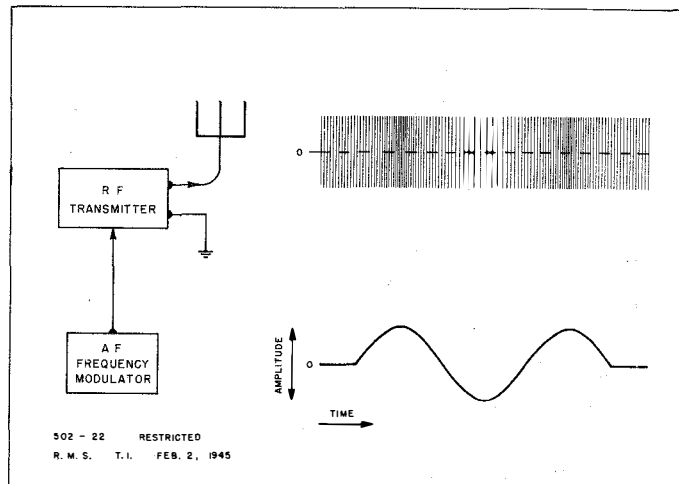

Fig. 22 Frequency modulation.

3. **PHASE MODULATION:** The phase relations between the original RF and the radiated wave are varied according to the intelligence to be transmitted. This type of modulation is seldom used because it requires an excessively wide frequency band.

TRANSMITTER FUNDAMENTALS

DETERMINING PERCENTAGE OF MODULATION

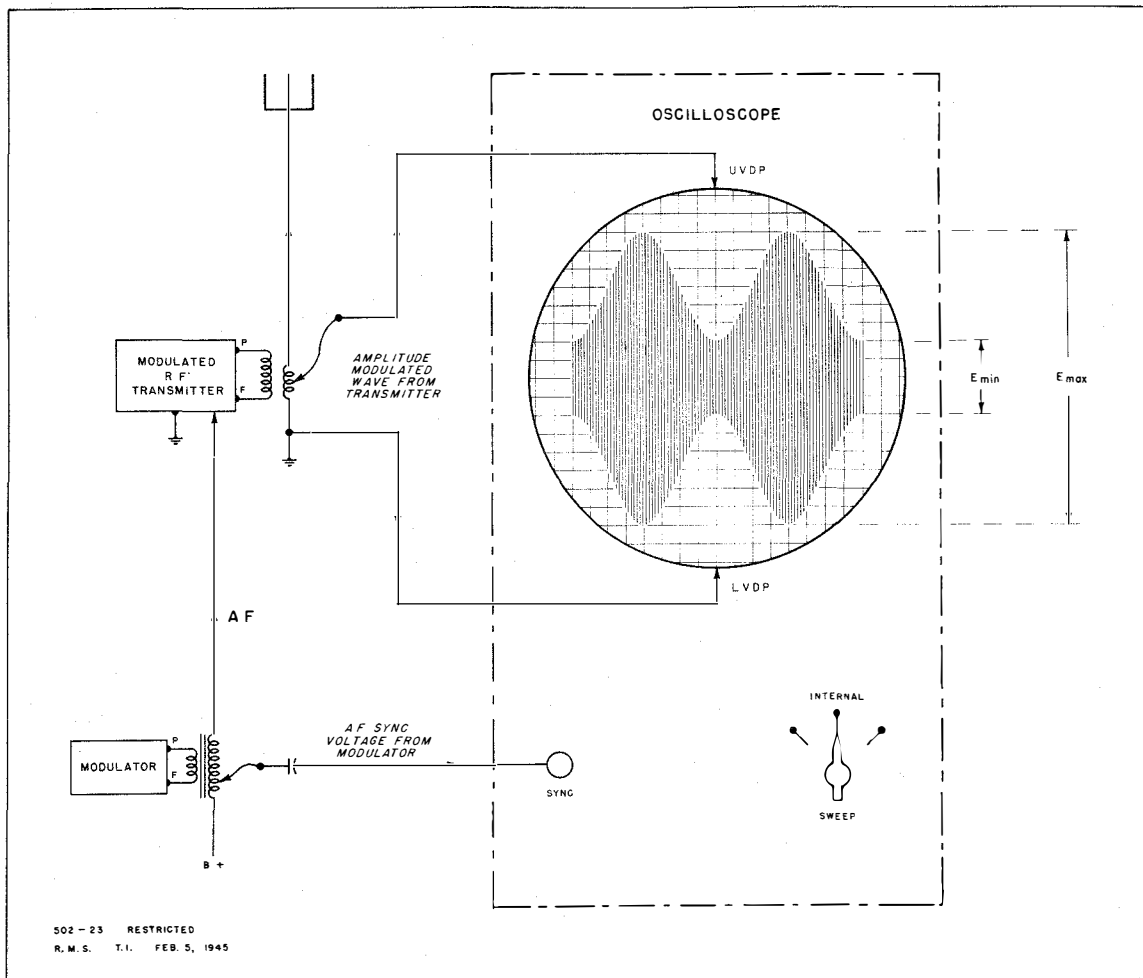

Fig. 23 Typical hookup for determining the percentage of modulation of an amplitude modulated RF wave.

1. GENERAL CIRCUIT CONDITIONS:

- (a) A small amount of amplitude modulated RF is coupled from the transmitter output to the vertical deflection plates of the oscilloscope.
- (b) The sweep frequency is approximately half the modulation frequency.

2. CALCULATION OF MODULATION PERCENTAGE:

- (a) Count the greatest number of squares covered vertically by the modulation envelope, and let that equal E_{max} .
- (b) Count the least number of squares covered vertically by the modulation envelope, and let that equal E_{min} .
- (c) Percentage of modulation = 100 times the modulation index M , where

$$M = \frac{E_{max} - E_{min}}{E_{max} + E_{min}}$$

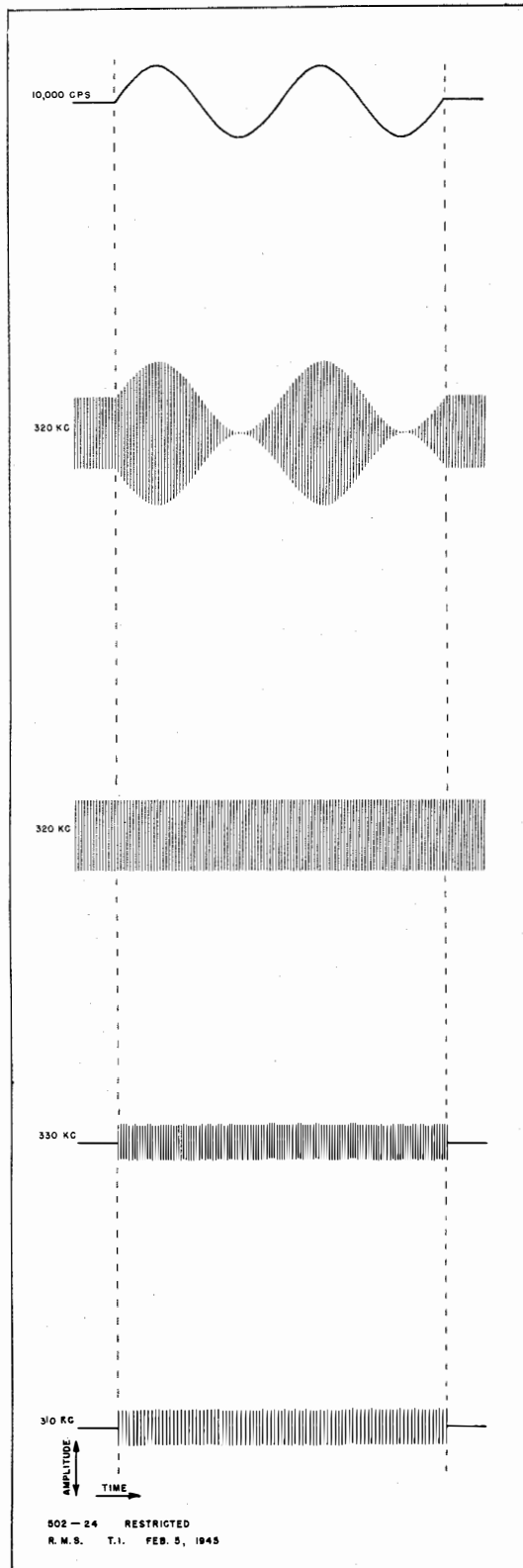

Audio frequency intelligence signal used to modulate the RF signal in the transmitter.

A 100% modulated RF wave as it leaves the antenna. This wave is a combination of several components, all of which are radio frequency waves.

The CARRIER component of the output wave is constant in both amplitude and frequency. The amplitude is equal to the average amplitude of the modulated wave.

The UPPER SIDE BAND is an additional component produced when the original RF wave is modulated. The amplitude is equal to half the carrier amplitude. The frequency is the *sum* of the carrier frequency and the AF modulation frequency.

The LOWER SIDE BAND is another component produced when the original RF wave is modulated. The amplitude is equal to half the carrier amplitude. The frequency is the *difference* between the carrier frequency and the AF modulation frequency.

Fig. 24 Components of an amplitude modulated wave.

TRANSMITTER FUNDAMENTALS

POWER RELATIONS IN AN AMPLITUDE MODULATED WAVE

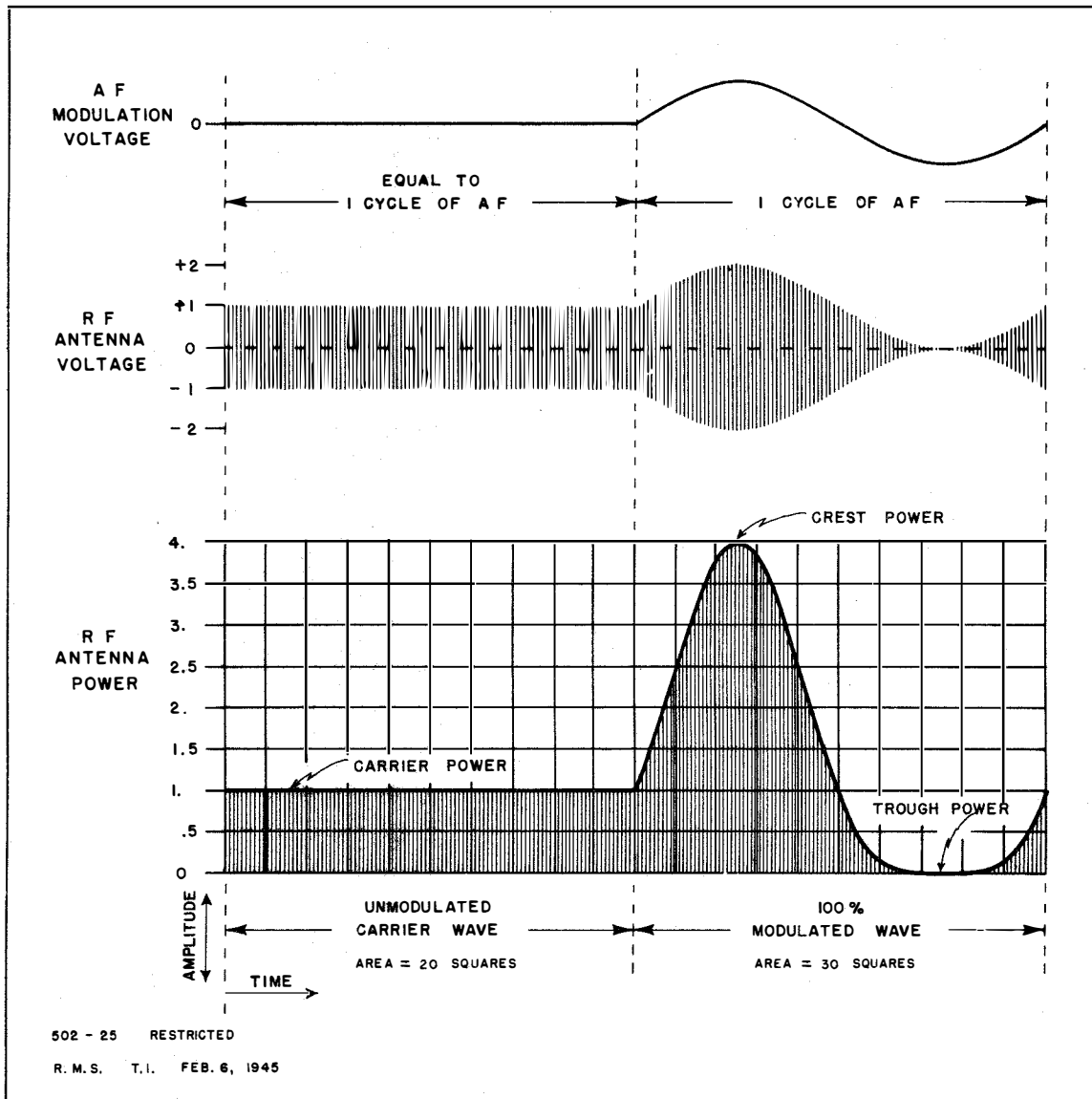

Fig. 25 Power relations in an amplitude modulated wave.

1. GENERAL CONDITIONS: Fig. 25 shows both an unmodulated carrier wave and a 100% modulated wave for comparison.

2. POWER RELATIONS:

- (a) Power is proportional to the square of the voltage. $P = \frac{E^2}{R}$
- (b) Crest power is four times carrier power.
- (c) Trough power is zero.
- (d) Average power in the modulated wave is 50% greater than carrier power, as shown in Fig. 25 by a comparison of the areas under the curves of antenna power.

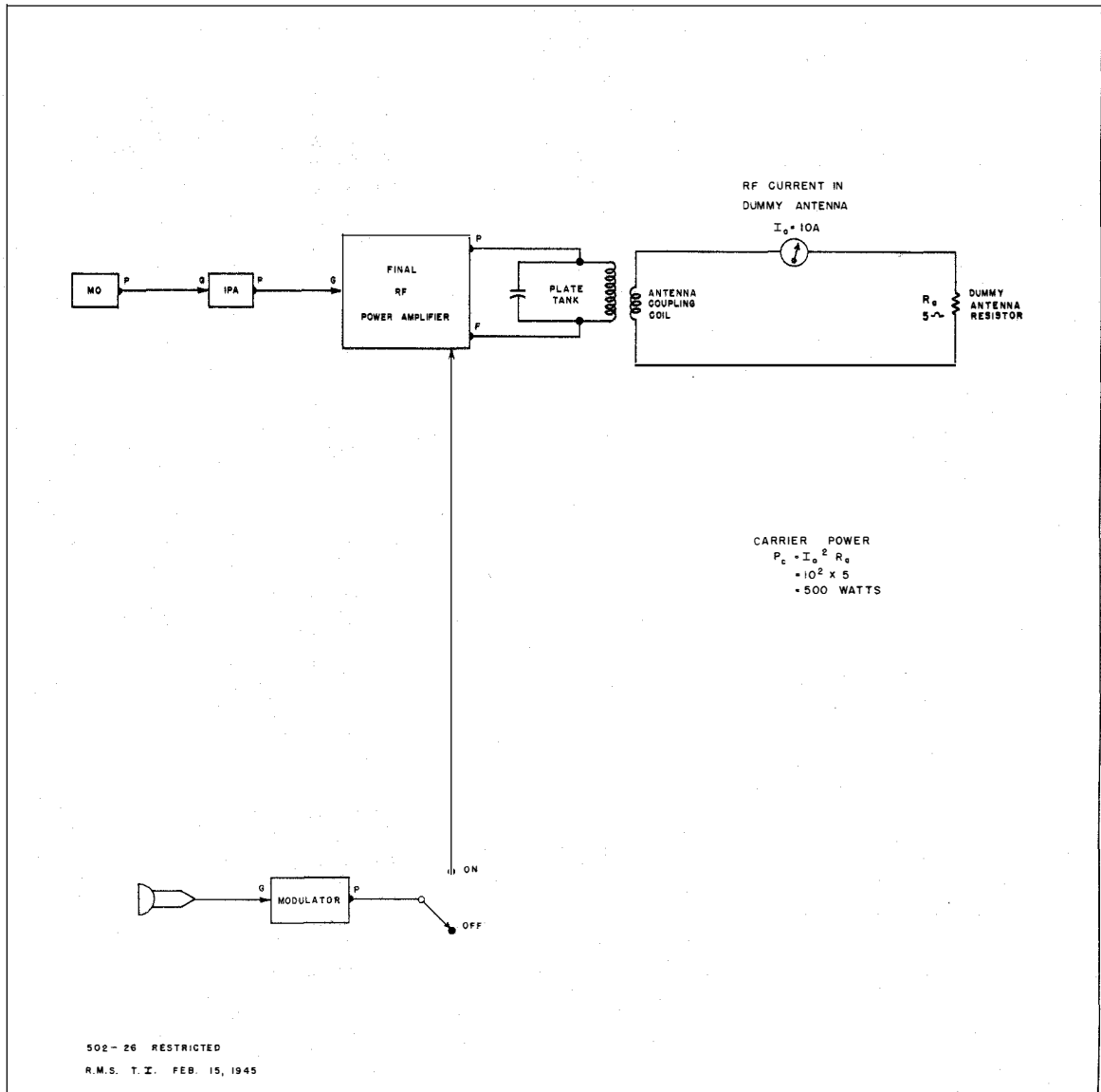

Fig. 26 Typical hookup for determining RF carrier power.

1. CARRIER POWER: $P_c = I_a^2 R_a$ where

- (a) P_c is carrier power.
- (b) I_a is dummy antenna current.
- (c) R_a is dummy antenna resistance.

2. EXAMPLE: In Fig. 26,

- (a) Dummy antenna current is 10 amperes.
- (b) Dummy antenna resistance is 5 ohms.
- (c) Carrier power $P_c = 10 \times 10 \times 5 = 500$ watts.

TRANSMITTER FUNDAMENTALS

SIDE BAND POWER IN AN AMPLITUDE MODULATED WAVE

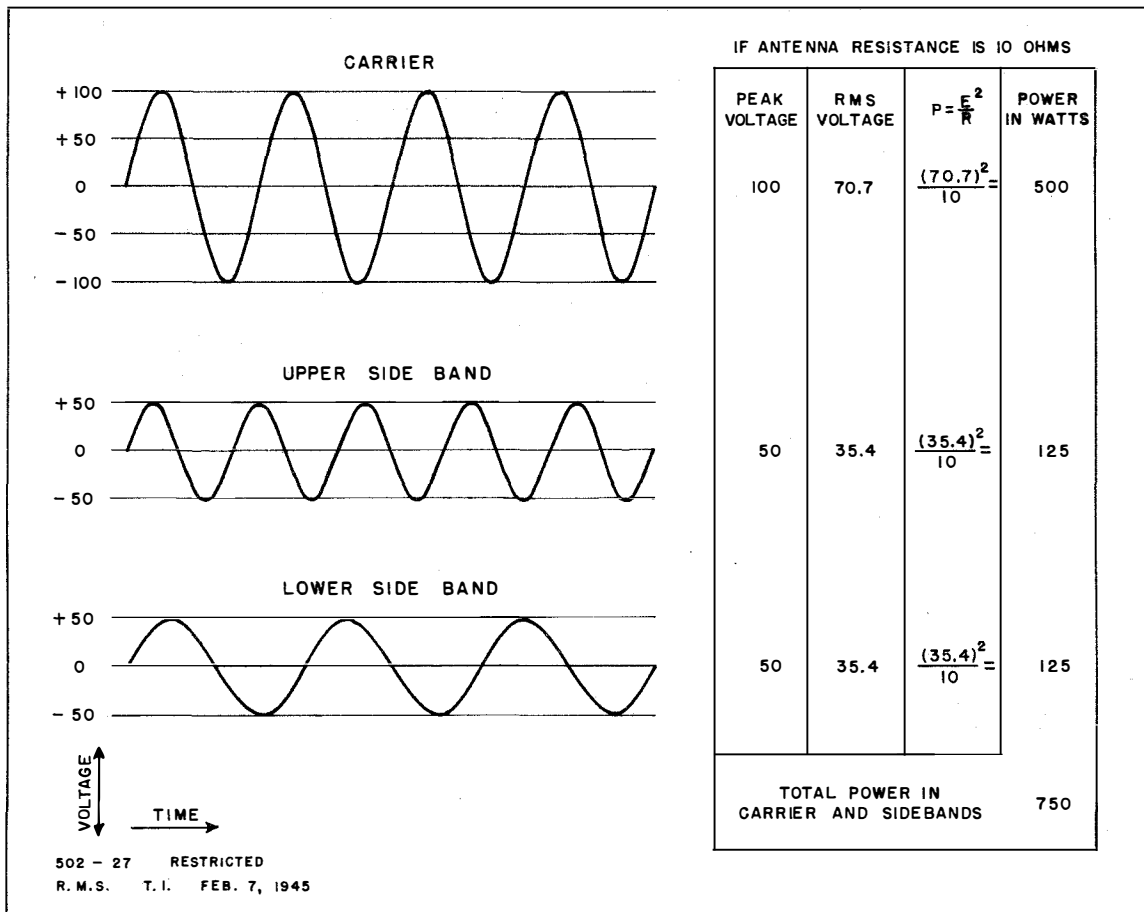

Fig. 27 Components of a modulated wave, showing side band power.

1. PURPOSE: To determine the side band power in an amplitude modulated wave for any percentage of modulation.

2. GENERAL CONDITIONS:

- (a) Fig. 27 shows side band power for 100% modulation.
 (b) For percentages of modulation other than 100%, side band power varies as the square of the side band voltage.

3. UPPER SIDE BAND POWER: $USBP = \frac{M^2}{4} P_c$ where

(a) M = modulation factor.

(b) P_c = carrier power.

4. LOWER SIDE BAND POWER: $LSBP = \frac{M^2}{4} P_c$ where the units are the same.

5. TOTAL SIDE BAND POWER: $SBP = \frac{M^2}{2} P_c$ where the units are the same.

1. ANTENNA CURRENT WITHOUT MODULATION:

$$I_o = \sqrt{\frac{P_c}{R_a}}$$

Where

I_o is RF carrier current,
 P_c is carrier power,
 R_a is antenna resistance.

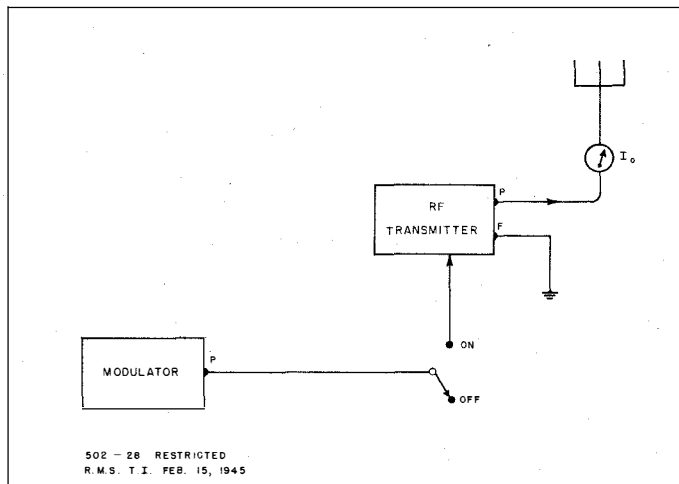

Fig. 28 RF transmitter without modulation.

2. ANTENNA CURRENT WITH MODULATION:

$$I_{am} = I_o \sqrt{\frac{M^2}{2} + 1}$$

Where

I_{am} is RF antenna current with modulation,
 I_o is RF carrier current,
 M is modulation factor.

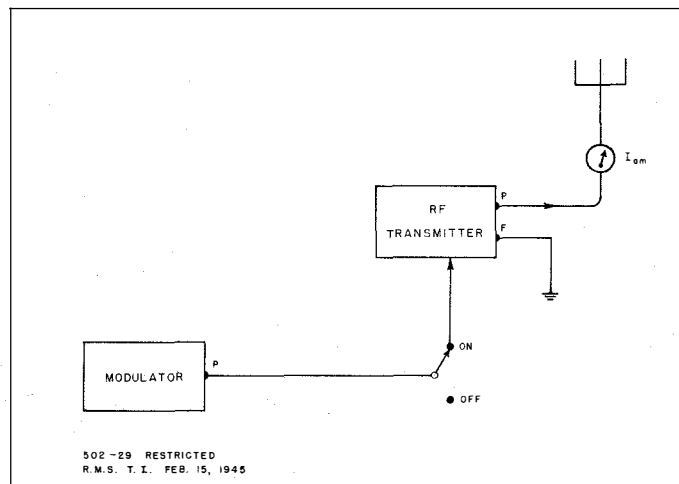

Fig. 29 RF transmitter with modulation.

3. ANTENNA CURRENT INCREASE WITH 100% MODULATION:

(a) $I_{am} = I_o \sqrt{\frac{M^2}{2} + 1}$

(b) At 100% modulation, $I_{am} = I_o \sqrt{\frac{1}{2} + 1} = I_o \sqrt{1.5} = I_o \times 1.225$.

4. RESULT: When 100% sinusoidal modulation is applied to an RF transmitter, the antenna current is 22.5% greater than when no modulation is applied.

TRANSMITTER FUNDAMENTALS

PLATE MODULATED AMPLIFIER

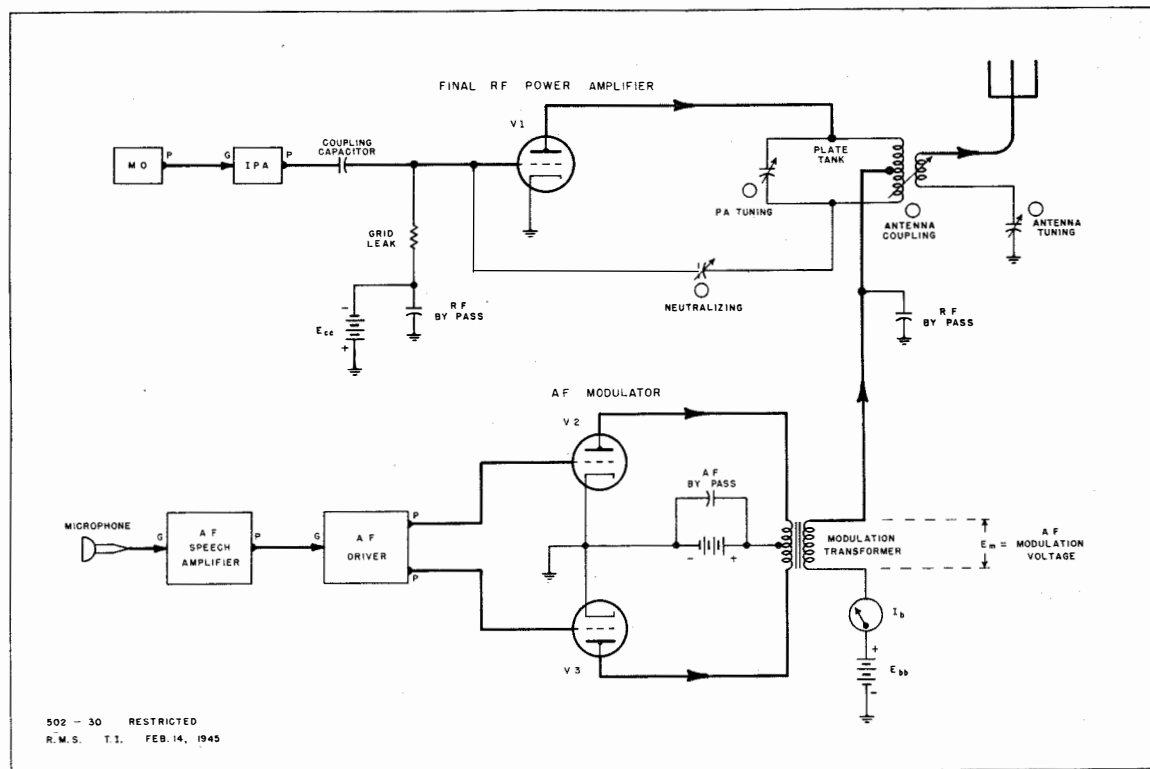

Fig. 30 Plate modulated amplifier.

1. GENERAL CIRCUIT CONDITIONS:

- (a) RF power amplifier (V-1) is operated Class C.
- (b) AF modulator (V-2 and V-3) is operated push pull Class B.

2. OPERATION:

- (a) The RF power amplifier (V-1) amplifies the RF excitation applied to its grid, developing an RF voltage across the plate tank circuit.
- (b) An RF voltage is induced in the antenna circuit.
- (c) The modulator (V-2 and V-3) amplifies the AF voltage applied to its grids, developing an AF voltage in the modulator plate circuit.
- (d) An AF modulation voltage E_m is induced in the secondary of the modulation transformer.
- (e) The AF modulation voltage E_m is in series with the DC plate supply voltage E_{bb} of the RF power amplifier (V-1).
- (f) As E_m swings in the positive direction, plate voltage of the PA (V-1) increases, causing plate current and RF power output to increase.
- (g) As E_m swings in the negative direction, plate voltage of the PA (V-1) decreases, causing plate current and RF power output to decrease.

3. RESULTS: An AF signal in the modulator causes the RF power output of the PA to vary according to the intelligence to be transmitted. The linearity of plate modulation is good, and the plate efficiency of the PA is from 60 to 80 percent.

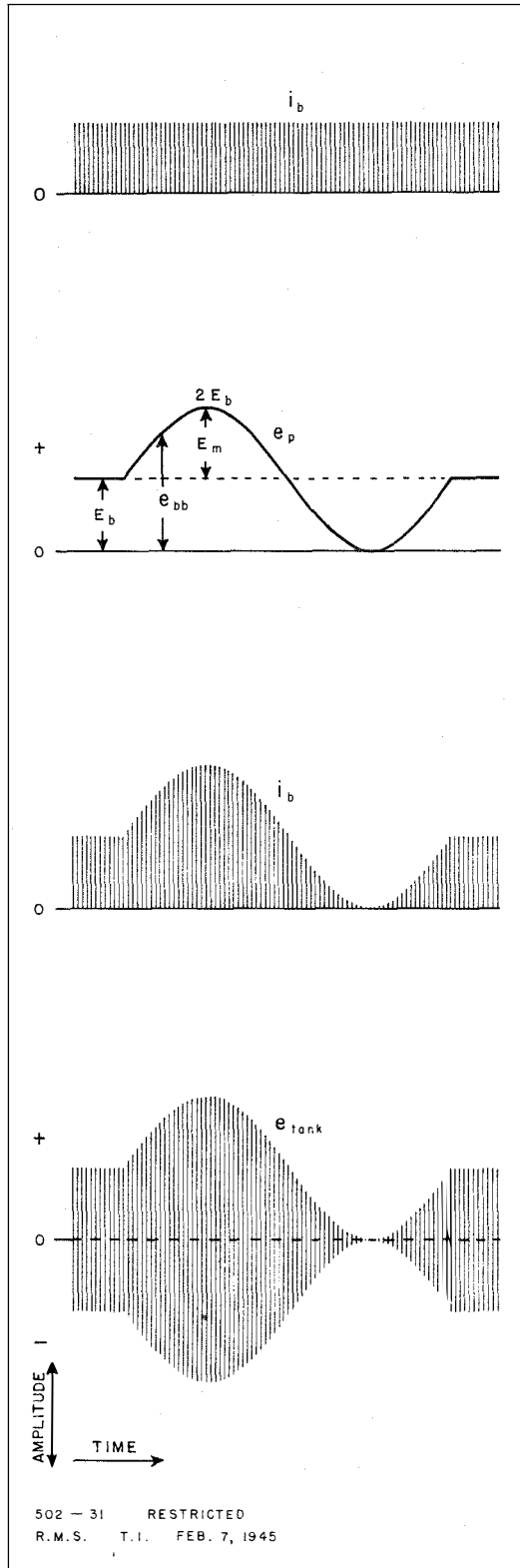

RF plate current of the normal Class C amplifier with no modulation applied. Each sharp pulse of plate current is of approximately 150° duration and occurs at an RF rate.

Modulated plate supply voltage of RF amplifier with 100% modulation. The plate supply voltage is varied between twice normal on positive modulation peaks and zero on negative peaks.

RF plate current of 100% modulated Class C amplifier. The sharp pulses of RF plate current follow the AF waveform of the applied plate voltage.

RF voltage developed across LC tank. The flywheel effect of the tuned tank circuit carries over the portion of each RF cycle in which no plate current flows, filling in the remainder of the modulated wave. The same waveform appears in the antenna circuit coupled to the tank.

Fig. 31 Waveforms of plate modulated amplifier.

TRANSMITTER FUNDAMENTALS

URNS RATIO OF MODULATION TRANSFORMER

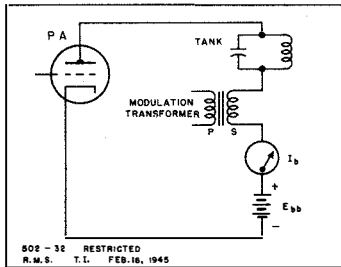

Fig. 32 Normal RF amplifier.

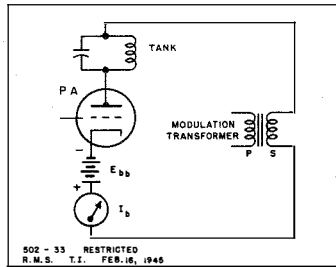

Fig. 33 Shunting action of RF amplifier across modulation transformer.

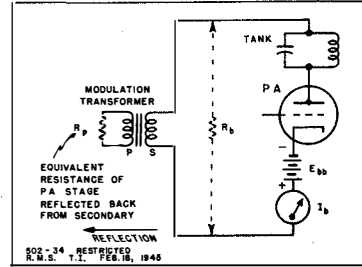

Fig. 34 Equivalent circuit of load on modulation transformer.

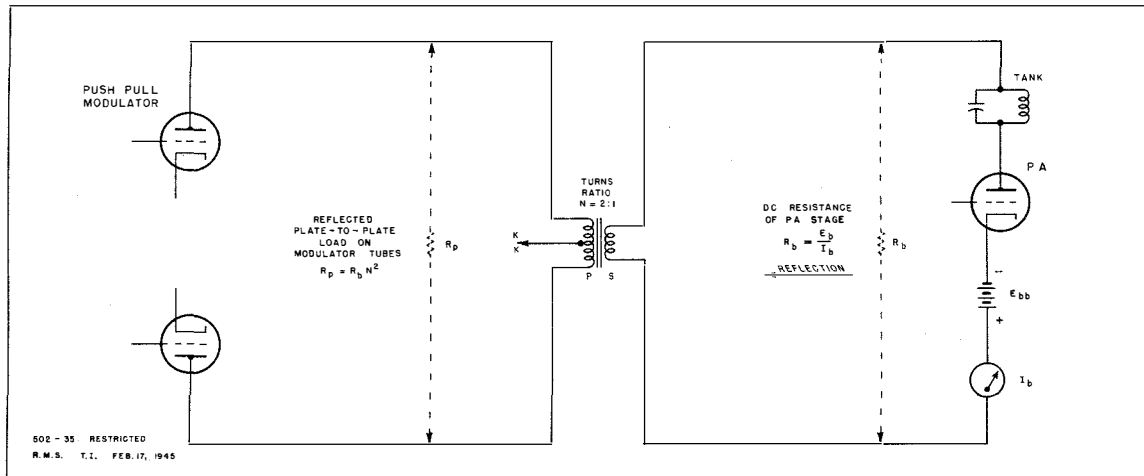

Fig. 35 Load on modulation transformer.

1. **PURPOSE:** To match the impedance between primary and secondary of a modulation transformer to obtain maximum undistorted power output.

2. **URNS RATIO** $N = \frac{N_p}{N_s}$ where N_p is the number of turns in the primary winding, and N_s is the number of turns in the secondary winding.

3. **REQUIRED TURNS RATIO** $= \sqrt{\frac{R_p}{R_b}}$ where R_p is the rated plate-to-plate resistance load of the modulator tubes, and R_b is the DC resistance of the RF power amplifier.

4. **EXAMPLE:** If the rated load R_p for the modulator tubes is 40,000 ohms, the DC plate voltage of the RF amplifier is 3,000 volts, and the DC plate current of the RF amplifier is 300 ma, then $R_b = 3,000 / .3 = 10,000$ ohms.

The required turns ratio $= \sqrt{\frac{R_p}{R_b}} = \sqrt{\frac{40,000}{10,000}} = \sqrt{4} = 2$, or a 2:1 step-down.

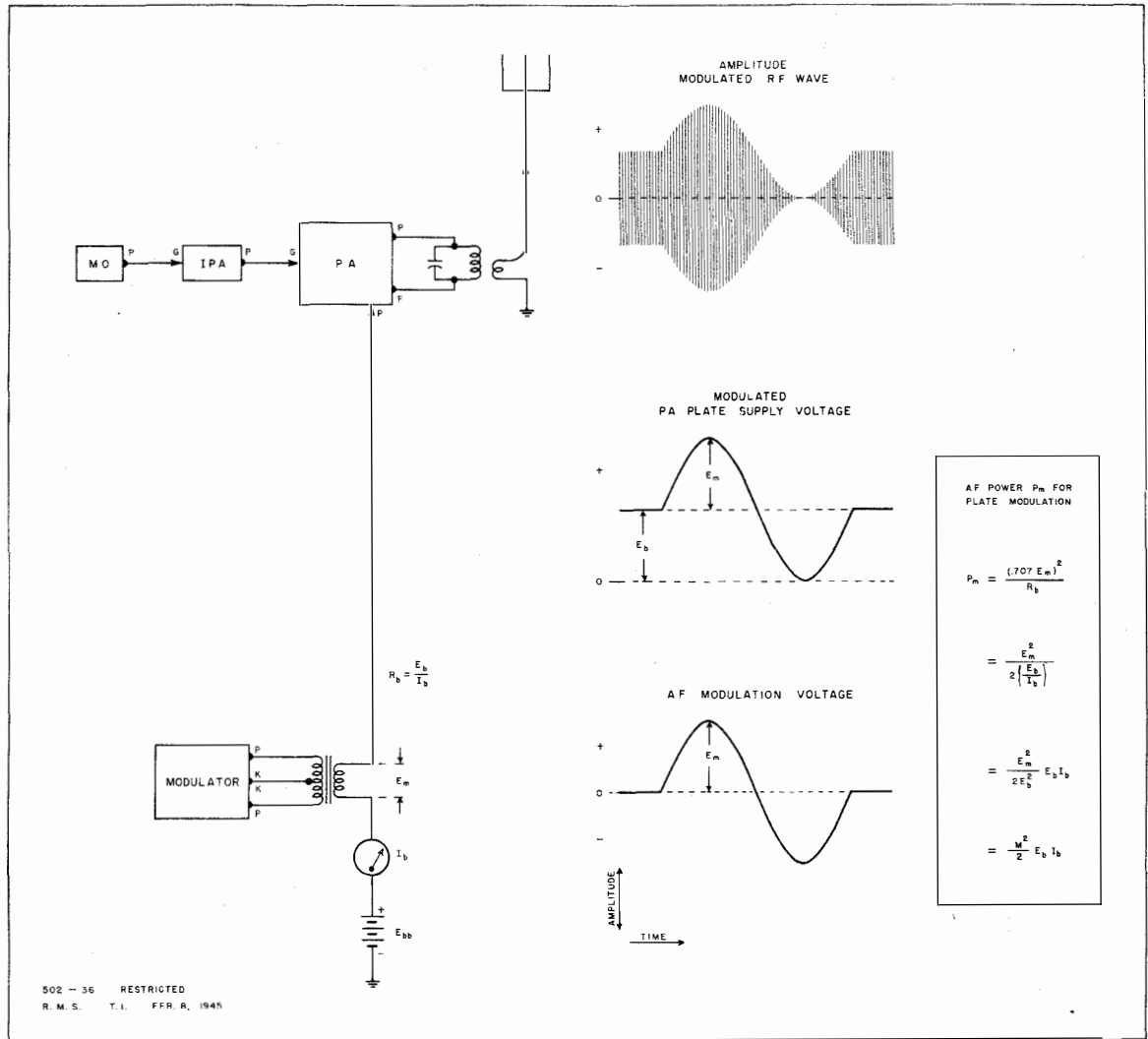

Fig. 36 AF power required from modulator.

1. GENERAL FORMULA: $P_m = \frac{M^2}{2} E_b I_b$ where P_m is the AF modulation power, M is the modulation factor, E_b is the DC plate voltage of the PA, and I_b is the DC plate current of the modulated stage (PA).
2. AF POWER FOR 100% PLATE MODULATION: $P_m = \frac{M^2}{2} E_b I_b = \frac{(1.0)^2}{2} E_b I_b = \frac{E_b I_b}{2}$, or one-half the DC plate power input to the modulated stage (PA).
3. EXAMPLE: If an RF power amplifier has DC plate voltage of 3,000 v., and DC plate current of 300 ma., how much AF power will be required to plate modulate the stage 100%?

$$P_m = \frac{M^2}{2} E_b I_b = \frac{(1.0)^2 \times 3,000 \times .3}{2} = \frac{900}{2} = 450 \text{ watts.}$$

TRANSMITTER FUNDAMENTALS

ADJUSTMENT OF PLATE MODULATED AMPLIFIER

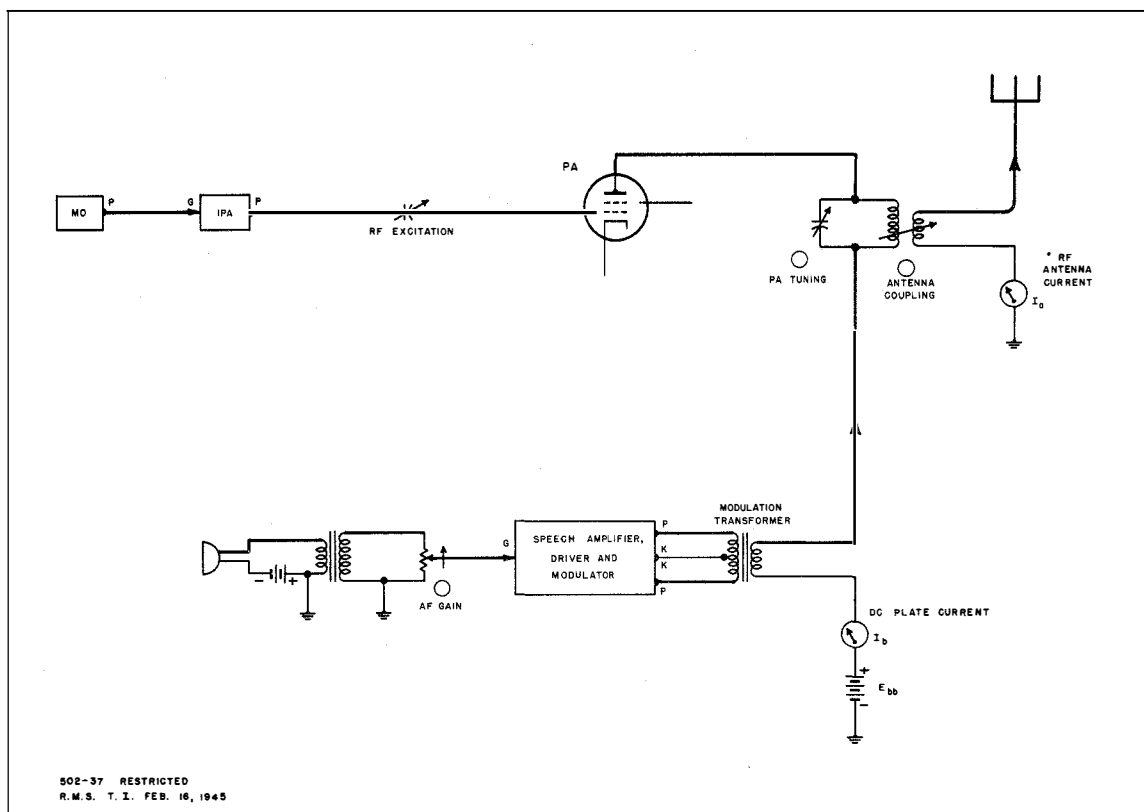

Fig. 37 Adjustment of plate modulated amplifier.

1. **PURPOSE:** To cause the RF amplifier (PA) to be modulated 100%.
2. **GENERAL CIRCUIT CONDITIONS:** The transmitter is tuned and operating.
3. **ADJUSTMENTS:**
 - (a) Adjust **ANTENNA COUPLING** until rated DC plate current flows. This places the correct load on the modulator.
 - (b) Apply sinusoidal modulation and increase **AF GAIN** of modulator until DC plate current just begins to change. This setting corresponds to 100% modulation. The RF antenna current should be 22.5% greater than it was with no modulation.
 - (c) If DC plate current *decreases* as **AF GAIN** is increased, one or more of the following adjustments will be necessary:
 - (1) Adjust **ANTENNA COUPLING** so the PA operates into the correct plate impedance.
 - (2) Replace weak PA tube. Filament emission may be insufficient to supply modulation peaks.
 - (3) Increase **RF EXCITATION** to the PA stage.
 - (4) Change PA grid bias voltage.
 - (d) If DC plate current *increases* on modulation peaks, overmodulation exists. Reduce **AF GAIN** of the modulator.

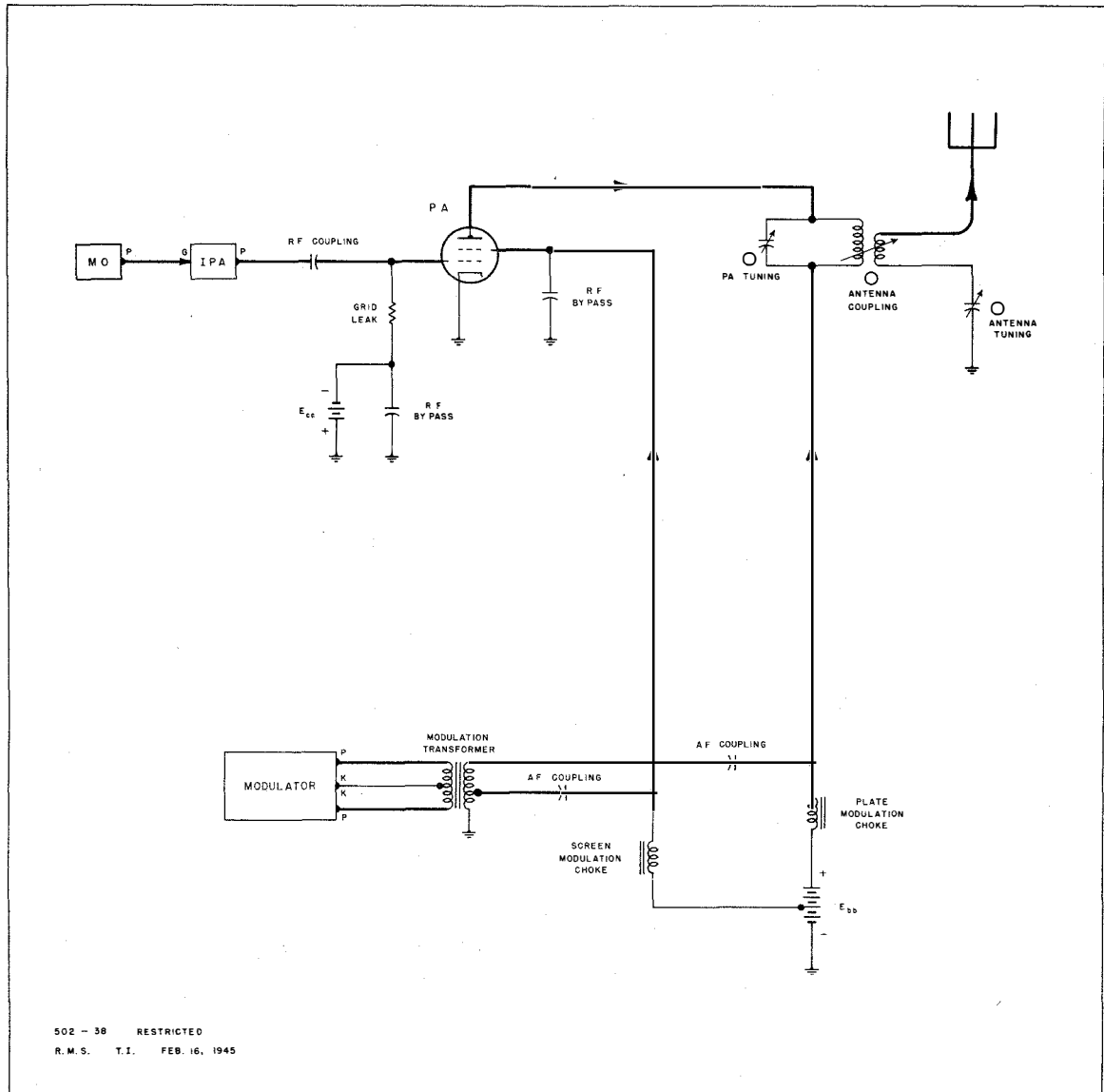

Fig. 38 Plate modulation of a screen grid tube.

1. OPERATION: Same as for a plate modulated triode except for the following:
 - (a) No neutralization is required because of the shielding action of the screen grid of the PA tube.
 - (b) In screen grid tubes, plate current is relatively independent of plate voltage. Thus the screen grid must be modulated in addition to the plate to prevent distortion. Screen modulation voltage is taken from a tap on the modulation transformer because the screen requires less power than the plate.
2. RESULT: Simultaneous modulation of both the plate and the screen circuits permits 100% modulation of tetrodes and pentodes without excessive distortion.

TRANSMITTER FUNDAMENTALS

A TYPICAL NAVY MODULATOR UNIT

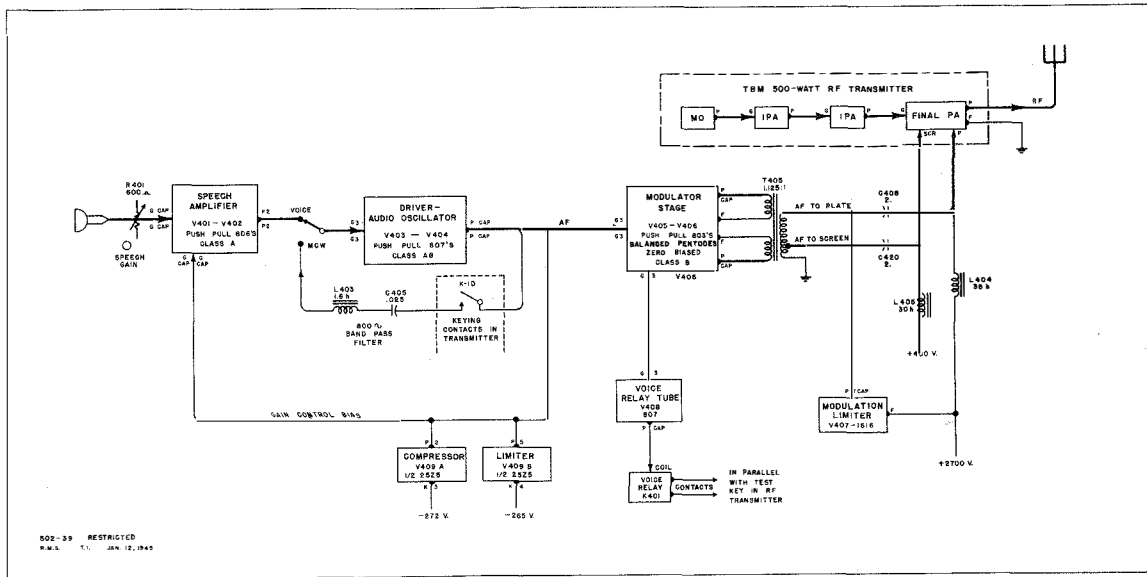

Fig. 39 TEM modulator unit, block diagram.

1. **PURPOSE:** To plate modulate a 500-watt RF transmitter.
2. **AMPLIFIER STAGES:** Three stages of push-pull transformer coupled audio amplification provide a maximum of 400 watts AF power for modulating the transmitter.
3. **AUXILIARY CIRCUITS:**
 - (a) **COMPRESSOR (V-409A) 1/2 25Z5:**
 - (1) Rectifies part of the driver AF output to be used as gain-controlling bias for the speech amplifier.
 - (b) **LIMITER (V-409B) 1/2 25Z5:**
 - (1) 7 volts fixed bias between cathode and plate permits operation on AF signal peaks only. Otherwise the limiter action is the same as that of the compressor.
 - (c) **MODULATION LIMITER (V-407) 1616 high voltage diode:**
 - (1) Prevents overmodulation. 2,700 volts fixed bias between cathode and plate prevents the modulation limiter from conducting until modulation exceeds 100%.
 - (d) **AUDIO OSCILLATOR:** For MCW operation, the speech amplifier is disconnected and the driver (V-403 and V-404) is converted into an audio oscillator through an 800-cycle band pass feedback circuit.
 - (e) **VOICE RELAY (K-401) and VOICE RELAY TUBE (V-408) 807:**
 - (1) Automatically turns on the RF carrier whenever an AF signal is fed to the modulator, and turns off the RF carrier when no AF signal is present.

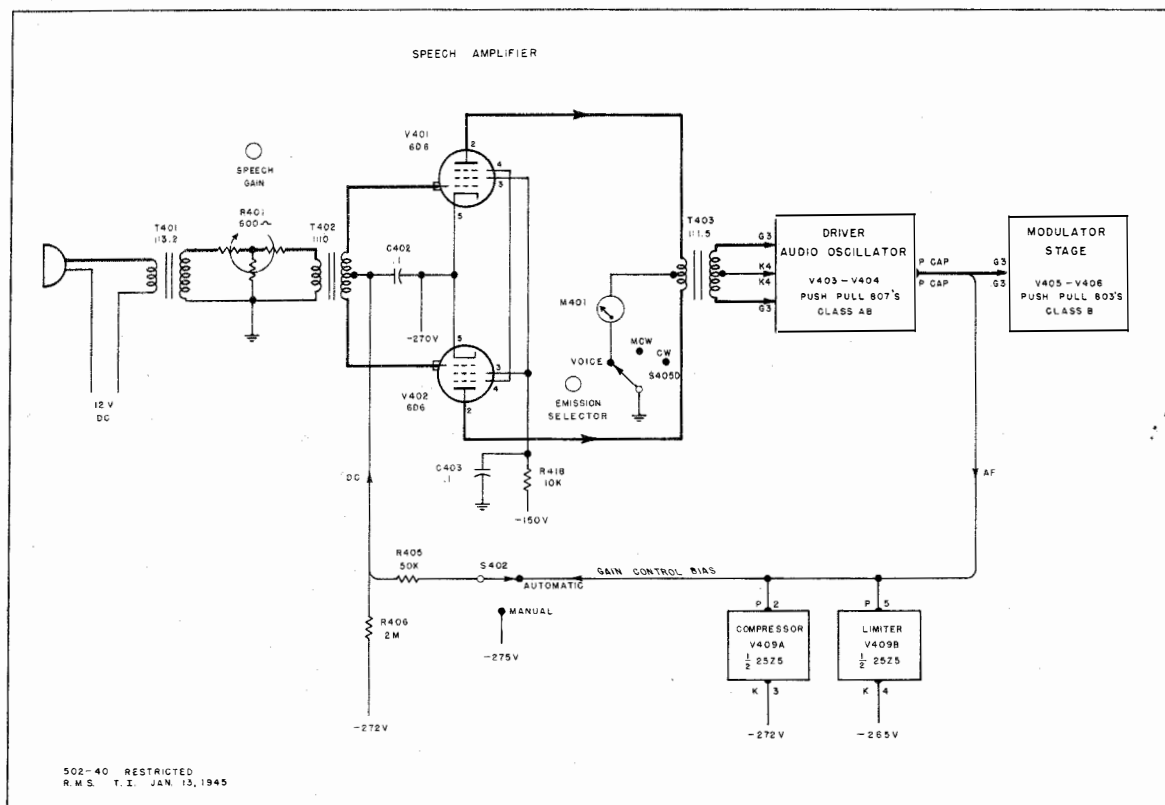

Fig. 40 TBM speech amplifier.

1. **PURPOSE:** To amplify the AF voltage from the microphone.
2. **GENERAL CIRCUIT CONDITIONS:**
 - (a) Class A voltage amplifier.
 - (b) Push-pull transformer coupled.
 - (c) Variable-MU tubes (6D6's).
 - (d) Plates are grounded. All other elements negative with respect to DC ground.
3. **OPERATION:**
 - (a) AF current from the microphone flows through the primary of the microphone transformer (T-401), inducing AF voltage in the secondary.
 - (b) The amount of AF voltage fed to the primary of T-402 is controlled by the SPEECH GAIN attenuator (R-401).
 - (c) The AF voltage is coupled to the grids of the speech amplifier through T-402.
 - (d) The AF voltage is amplified sufficiently by the speech amplifier to excite the grids of the driver stage.
 - (e) In MANUAL position of the GAIN switch (S-402), the speech amplifier grids are biased 5 volts negative by applying -270 volts to the cathodes and -275 volts to the grids.
 - (f) In AUTOMATIC position of the GAIN switch (S-402), the speech amplifier grid bias is controlled by the compressor (V-409A) and the limiter (V-409B).

TRANSMITTER FUNDAMENTALS

TBM DRIVER - AUDIO OSCILLATOR

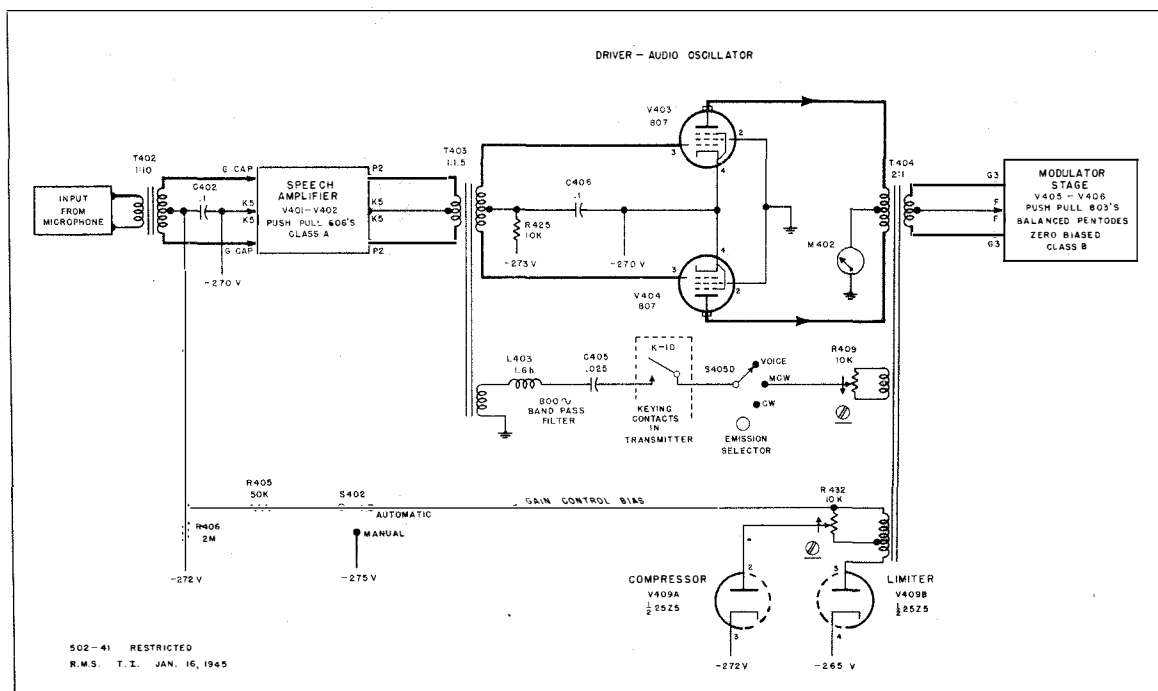

Fig. 41 TBM driver-audio oscillator.

1. PURPOSES:

- (a) For VOICE operation, to provide *power amplification* of the speech signal from the speech amplifier.
- (b) For MCW operation, to generate an 800-cycle signal.

2. GENERAL CIRCUIT CONDITIONS:

- (a) Class AB power amplifier.
- (b) Push-pull transformer coupled.
- (c) Plate and screen are grounded. All other elements negative with respect to DC ground.

3. OPERATION AS A DRIVER:

- (a) The AF signal coupled from the speech amplifier through T-403 is amplified sufficiently to drive the grids of the modulator tubes.
- (b) The driver must be a power amplifier because the grids of the Class B modulator tubes draw current during part of the cycle.

4. OPERATION AS AN AUDIO OSCILLATOR:

- (a) With **EMISSION SELECTOR** in MCW position, S-405D connects an 800-cycle band pass filter (L-403 and C-405) in a feedback circuit to produce audio oscillation.
- (b) The audio oscillator is keyed by contacts K-1D of the keying relay in the transmitter.
- (c) The power output of the audio oscillator is factory-adjusted by R-409 to produce 100% modulation of the transmitter.

TBM COMPRESSOR - LIMITER

35

1. **PURPOSE:** To compensate for wide variations in speech input level.
2. **GENERAL CIRCUIT CONDITIONS:**
 - (a) The plates of both the compressor (V-409A) and the limiter (V-409B) are negative with respect to ground by 272 volts and the voltage across R-406.
 - (b) The cathode of the compressor (V-409A) is maintained at -272 volts.
 - (c) The cathode of the limiter (V-409B) is maintained at -265 volts.
3. **OPERATION:**
 - (a) When the GAIN switch (S-402) is in AUTOMATIC, a portion of the AF output from the driver is fed from an additional winding on T-404 to the plates of both the compressor (V-409A) and the limiter (V-409B).
 - (b) With no AF signal, neither the compressor nor the limiter conduct. The speech amplifier grids are biased 2 volts negative by applying -270 volts to the cathodes and -272 volts to the grids.
 - (c) With a normal AF signal, the voltage across the compressor-limiter winding of T-404 causes the compressor (V-409A) to conduct during signal peaks until the grid capacitor (C-402) is charged to the normal bias of -5 volts.
 - (d) With an excessive AF signal, the voltage at the plate of the limiter (V-409B) also becomes less negative than the fixed cathode voltage during signal peaks. Then both the compressor and the limiter conduct, adding to the negative charge on the grid capacitor (C-402) until the speech amplifier bias is sufficiently negative to prevent excessive gain.
 - (e) If the signal remains at a constant level after the necessary bias is established, the limiter ceases to conduct, and the compressor conducts only enough on signal peaks to replace the leakage from the grid capacitor (C-402) through the 2-megohm resistor (R-406).
 - (f) If the signal level decreases, the compressor also ceases to conduct. The grid capacitor (C-402) then discharges through R-406, decreasing the negative bias to compensate for the reduction in AF signal.
 - (g) The compressor sensitivity may be adjusted with R-432.

TRANSMITTER FUNDAMENTALS

TBM MODULATOR STAGE

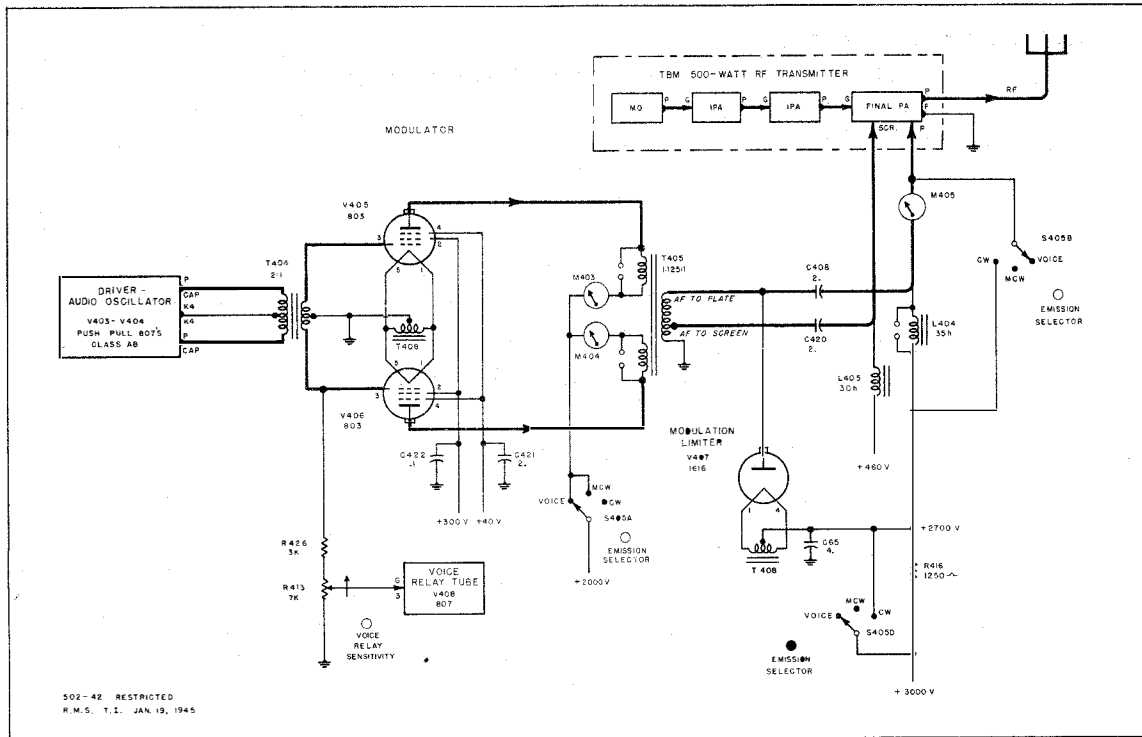

Fig. 42 TBM modulator stage.

1. **PURPOSE:** To develop *high AF power* to plate modulate a 500-watt RF transmitter.
2. **GENERAL CIRCUIT CONDITIONS:**
 - (a) Class B power amplifier.
 - (b) Push-pull transformer coupled.
 - (c) Zero biased.
3. **OPERATION:**
 - (a) AF signal power coupled from the driver through T-404 is amplified to provide 400 watts maximum from the modulation transformer (T-405).
 - (b) 365 watts of AF power is coupled through C-408 to the plate of the PA in the transmitter for 100% modulation.
 - (c) 10 watts of AF power is coupled through C-420 to the screen of the PA in the transmitter for 100% modulation.
 - (d) C-408 and C-420 also block DC from the secondary of the modulation transformer (T-405) to prevent core saturation.
 - (e) Modulation chokes (L-404 and L-405) prevent loss of AF power in the DC power supply.
 - (f) M-405 measures the percentage of modulation.
 - (g) R-416 reduces the plate voltage of the PA to +2,700 volts for VOICE and MCW so plate dissipation will not be excessive during modulation.
 - (h) Spark gaps across T-405 and L-404 prevent insulation breakdown if the modulator is operated without proper load.

1. **PURPOSE:** To prevent overmodulation.
2. **GENERAL CIRCUIT CONDITIONS:**
 - (a) The DC plate voltage of the RF transmitter is 2,700 volts.
 - (b) The plate of the modulation limiter diode (V-407) is biased 2,700 volts negative with respect to the cathode.
3. **OPERATION:**
 - (a) On positive modulation peaks, if the AF modulation voltage exceeds 2,700 volts the bias is overcome and the modulation limiter conducts.
 - (b) While conducting, V-407 acts as a low resistance, clipping off the positive peaks of all audio voltages in excess of 2,700 volts.

TBM VOICE RELAY CARRIER CONTROL

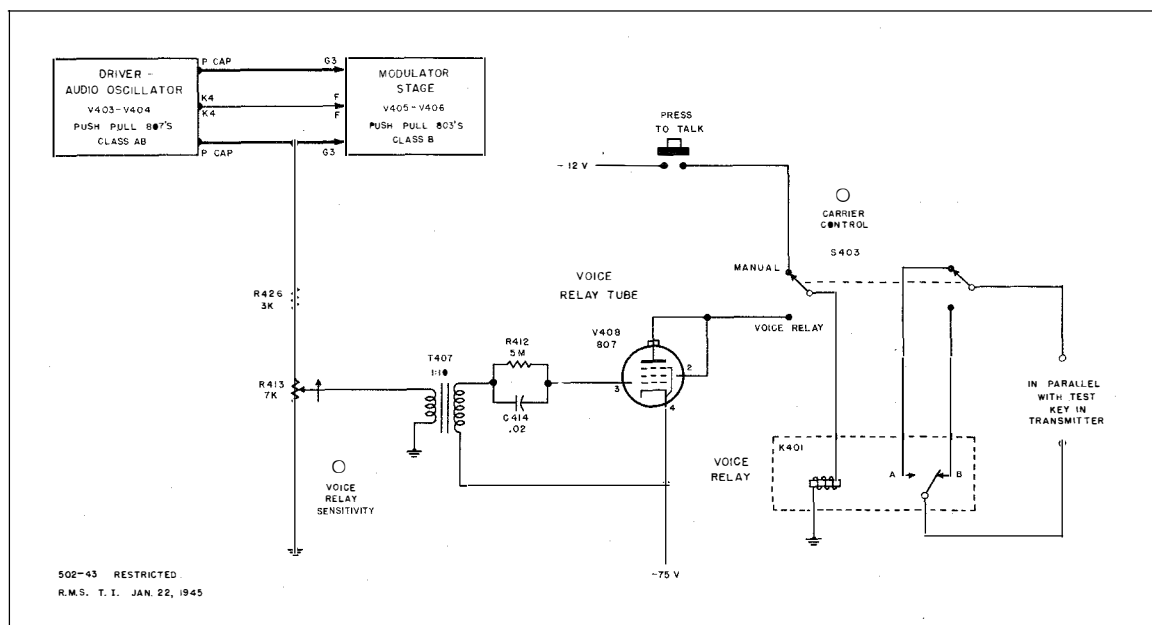

Fig. 43 TBM carrier control circuit in MANUAL position.

1. **PURPOSE:** To automatically turn on the RF carrier by speaking into the microphone, and turn off the RF carrier when no AF signal is present.
2. **GENERAL CIRCUIT CONDITIONS:** Depending on the position of CARRIER CONTROL switch (S-403), the voice relay (K-401) may be energized either from the 12-v. DC power supply or from the plate and screen current of the voice relay tube (V-408).
3. **OPERATION WITH CARRIER CONTROL SWITCH (S-403) IN MANUAL POSITION:**
 - (a) Whenever a TALK switch is closed, either at the modulator panel or at a remote telephone unit, the voice relay is energized from the 12-v. power supply and closes contacts K-401A to turn on the RF carrier.

TRANSMITTER FUNDAMENTALS

TBM VOICE RELAY CARRIER CONTROL (CONTINUED)

4. OPERATION WITH CARRIER CONTROL SWITCH (S-403) IN VOICE RELAY POSITION:

- (a) With no AF signal, the voice relay tube (V-408) has zero grid bias, and conducts sufficient current to energize the voice relay (K-401) to hold contacts K-401B open and keep the RF carrier off.
- (b) When an AF signal is applied to the modulator, a portion of the signal is fed through T-407 to the grid of the voice relay tube (V-408).
- (c) During each positive signal peak, grid current of V-408 charges the grid capacitor (C-414) negative on the grid side, through the low resistance between cathode and positive grid.
- (d) When no grid current flows, the cathode-to-grid resistance is high, and C-414 discharges slowly through the 5-megohm resistor (R-412).
- (e) After a few cycles, C-414 becomes charged sufficiently negative to bias V-408 to cutoff. This de-energizes the voice relay (K-401), allowing contacts K-401B to close and turn on the RF carrier.
- (f) If the AF signal stops, the grid capacitor (C-414) discharges through R-412 until the negative bias is lost and V-408 conducts, energizing the voice relay to open contacts K-401B and turn off the RF carrier.
- (g) The amount of AF signal required to turn on the RF carrier depends on the setting of the VOICE RELAY SENSITIVITY control (R-413) on the modulator front panel.

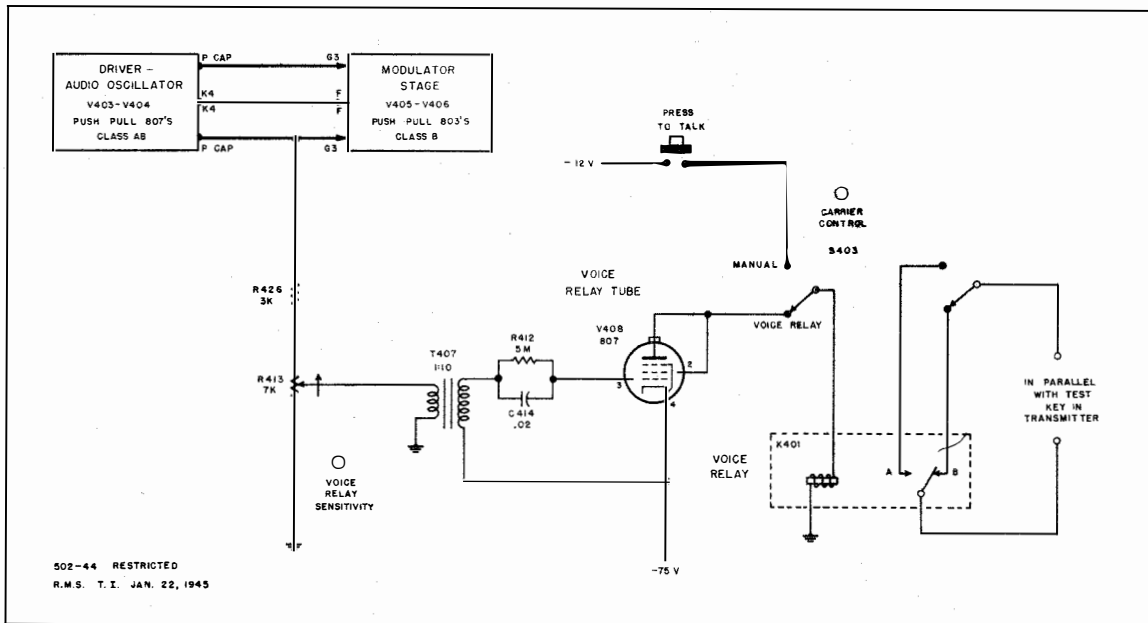
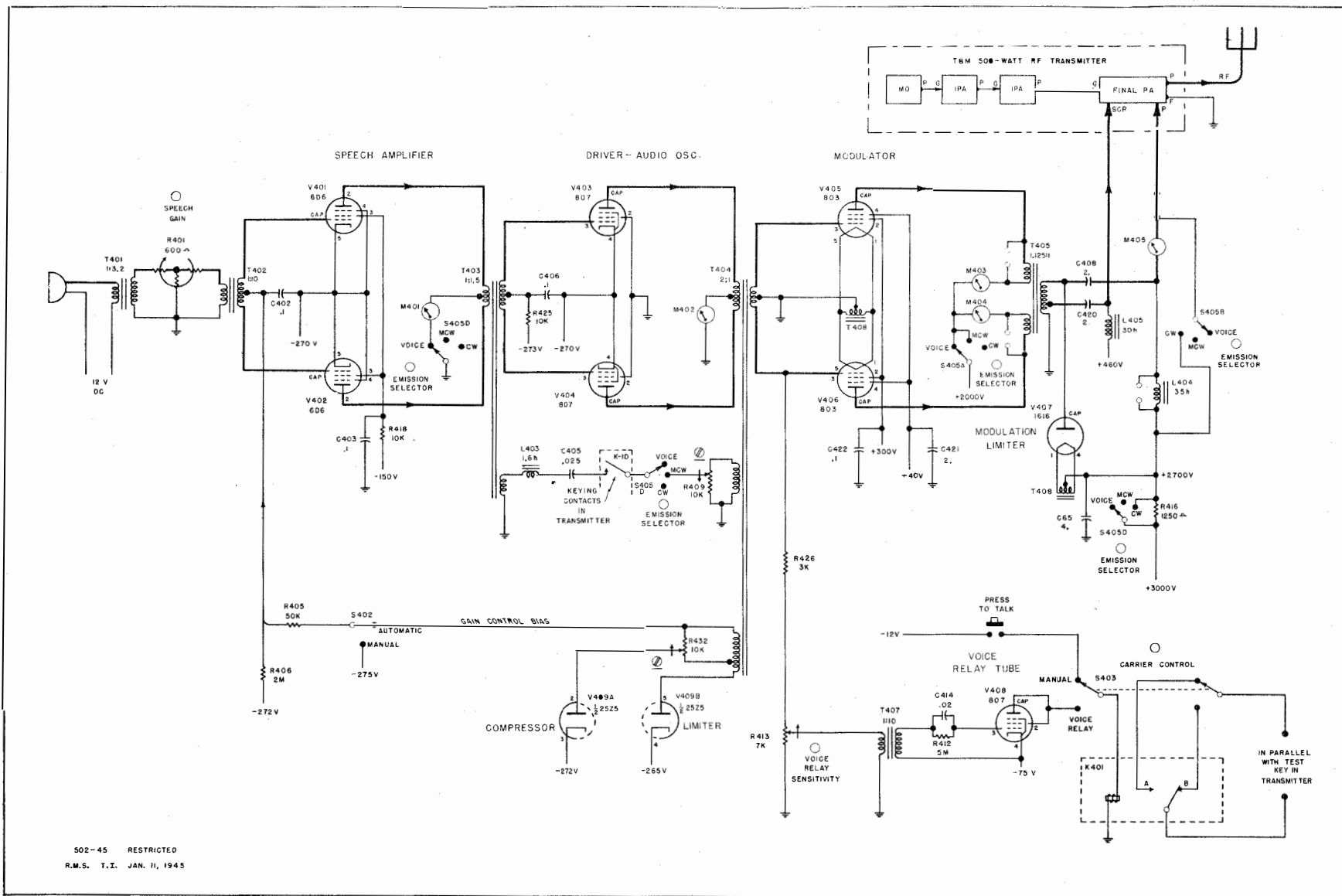

Fig. 44 TBM carrier control circuit in VOICE RELAY position.

TBM MODULATOR UNIT



502-45 RESTRICTED
R.M.S. T.I. JAN. 11, 1945

Fig. 45 TBM modulator unit, simplified schematic diagram.

TRANSMITTER FUNDAMENTALS

SUPPRESSOR GRID MODULATION

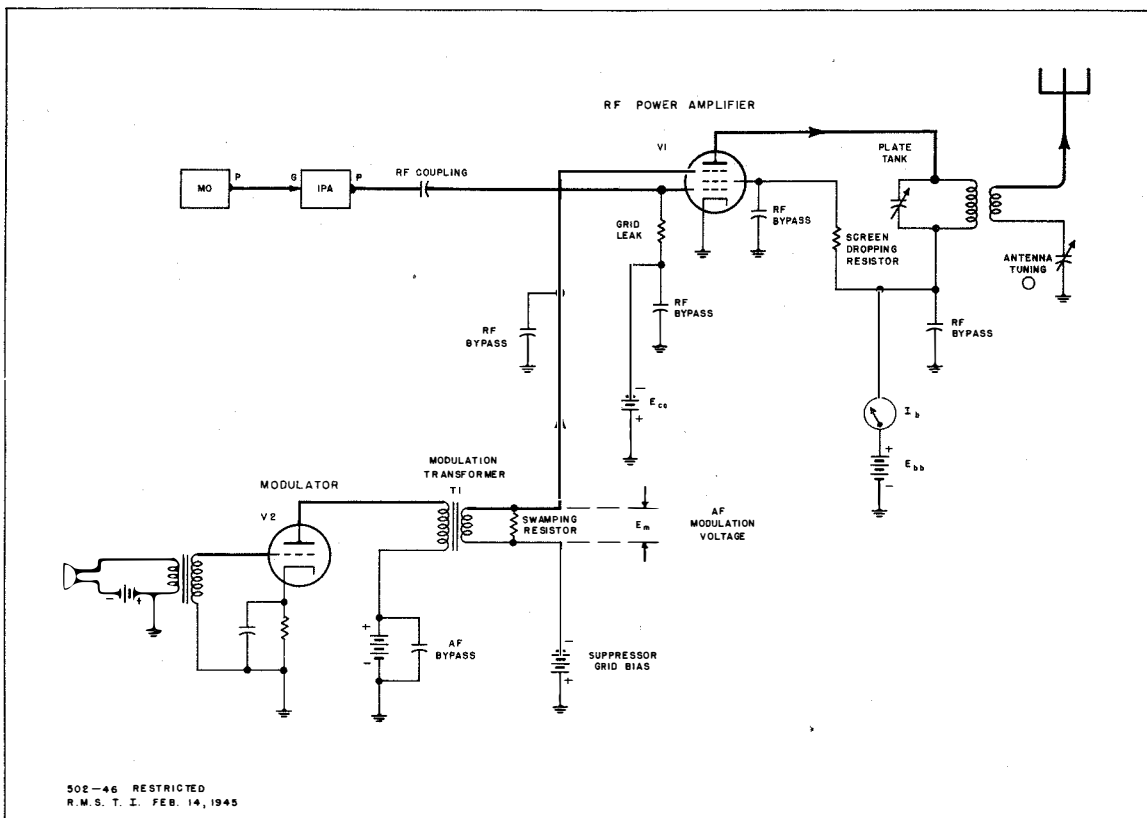

Fig. 46 Suppressor grid modulated amplifier.

1. GENERAL CIRCUIT CONDITIONS:

- (a) Class C RF power amplifier (V-1) with negative suppressor grid bias.
- (b) Class A modulator delivers the small amount of AF power required.

2. OPERATION:

- (a) The AF output E_m of the modulator (V-2) across the secondary of the modulation transformer (T-1) alternately adds to and subtracts from the negative suppressor grid bias voltage.
- (b) This causes the plate current of the RF power amplifier (V-1) to vary at an AF rate, producing a modulated wave in the transmitter output.
- (c) On positive modulation peaks, suppressor grid current flows, causing distortion. To minimize this distortion, a swamping resistor is connected across the secondary of the modulation transformer (T-1).
- (d) On negative modulation peaks, a virtual cathode is formed between the suppressor and screen, causing screen current to increase. The RF power output is limited by the allowable screen dissipation.

3. RESULTS:

- (a) Linearity with 100% modulation is poor due to the curvature in the suppressor grid voltage vs. plate current characteristic curve.
- (b) Plate efficiency of the RF power amplifier is from 30 to 40 percent.

SUPPRESSOR GRID MODULATED AMPLIFIER

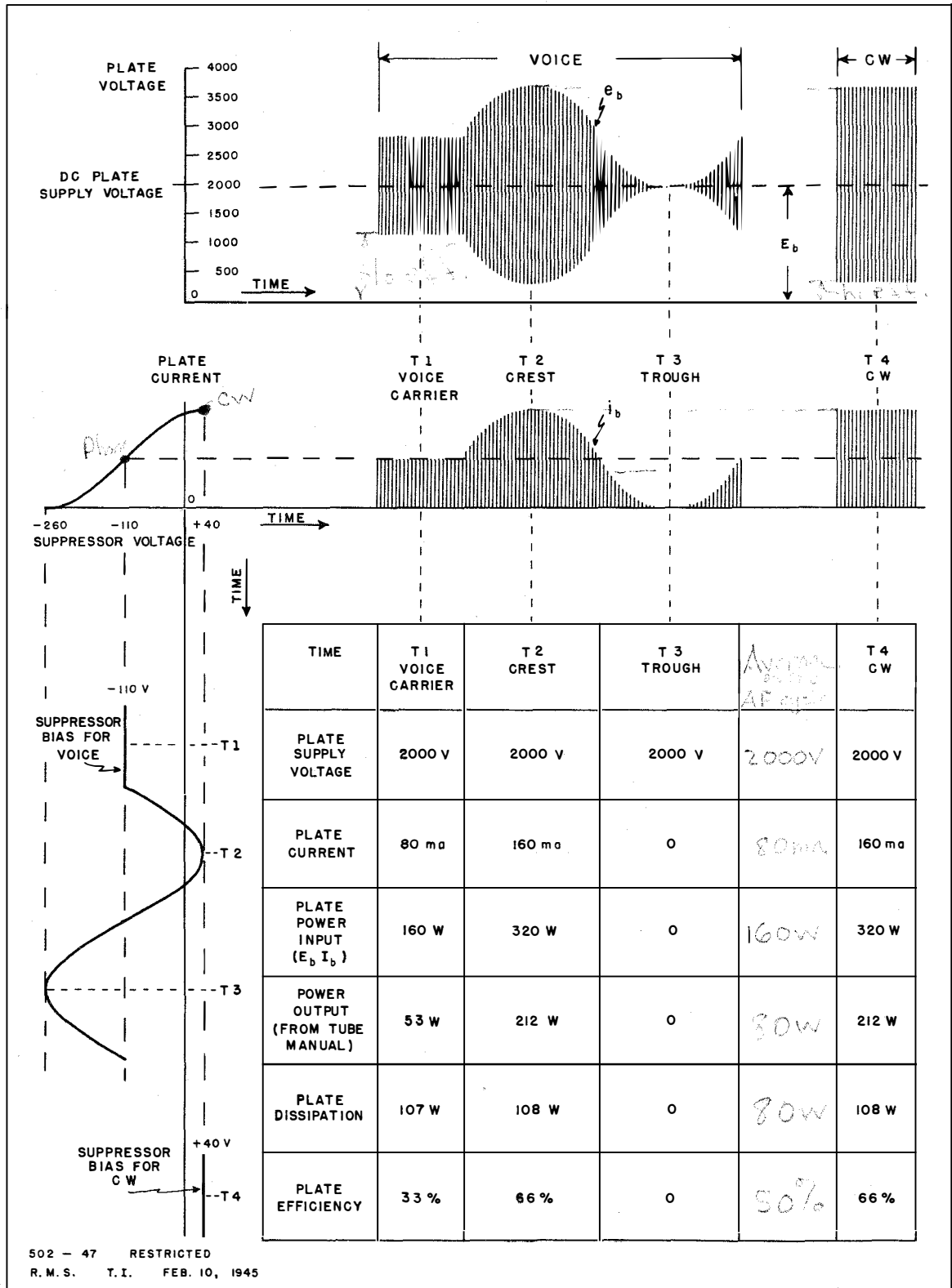

502 - 47 RESTRICTED
R. M. S. T. I. FEB. 10, 1945

Fig. 47 Voltage, current and power relations in suppressor grid modulated amplifier.

TRANSMITTER FUNDAMENTALS

GRID MODULATION

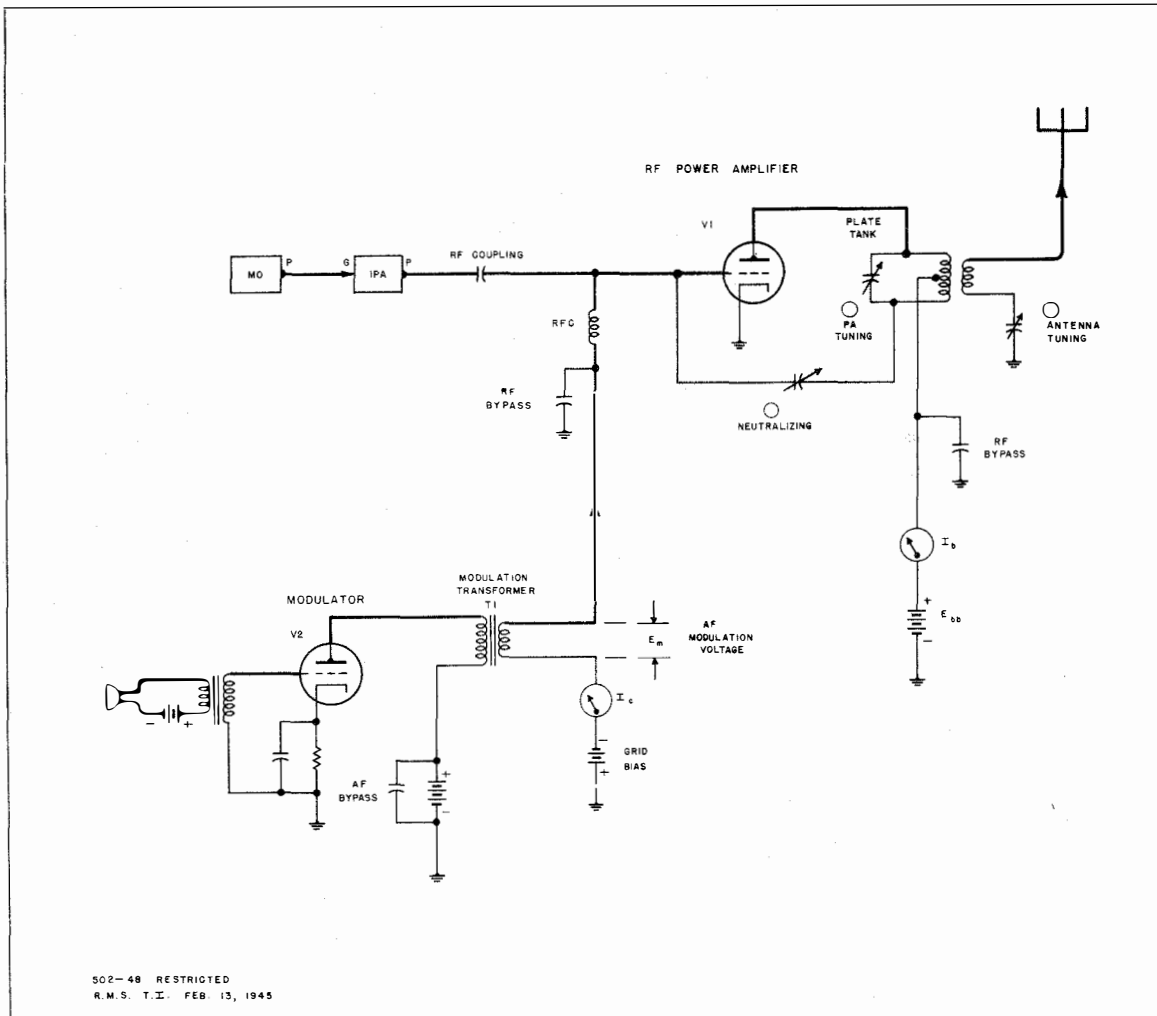

Fig. 48 Grid modulated amplifier.

1. GENERAL CIRCUIT CONDITIONS:

- (a) Class C_1 RF power amplifier.
- (b) Class A modulator delivers the small amount of AF power required.

2. OPERATION:

- (a) The AF output E_m of the modulator (V-2) across the secondary of the modulation transformer (T-1) alternately adds to and subtracts from the negative grid bias of the RF power amplifier (V-1).
- (b) This causes the plate current of the RF power amplifier (V-1) to vary at an AF rate, producing a modulated wave in the transmitter output.

3. RESULTS:

- (a) Linearity is good if no grid current flows in the RF power amplifier.
- (b) Plate efficiency of the RF power amplifier is from 30 to 40 percent.

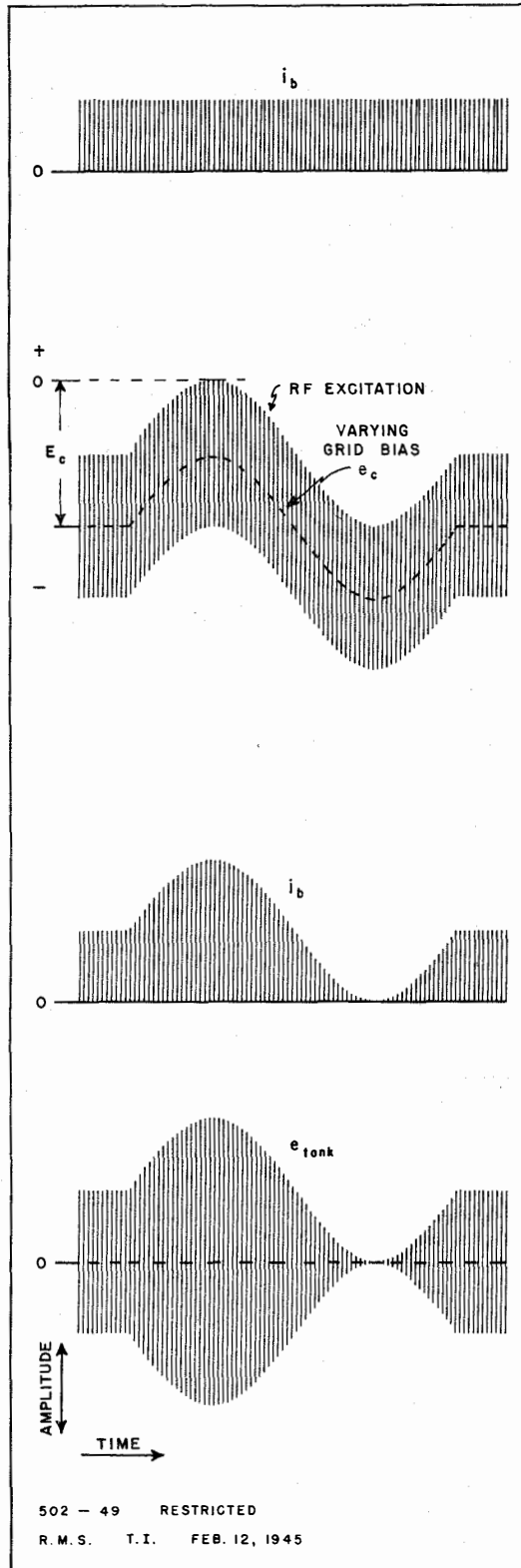

RF plate current with no modulation. The sharp pulses of plate current are constant in amplitude when no modulation is applied.

Grid voltage with 100% modulation. The DC grid bias of the modulated RF amplifier is varied above and below the unmodulated value to shift the operating point of the stage at an RF rate. RF excitation is superimposed on the modulated grid bias voltage to produce variations in plate current according to the intelligence to be transmitted.

Resulting RF plate current with 100% modulation. The sharp pulses of plate current follow the AF waveform of the grid bias voltage.

RF voltage developed across LC tank. The flywheel effect of the tuned tank circuit carries over the portion of each RF cycle in which no plate current flows, filling in the remainder of the modulated wave. The same waveform appears in the antenna circuit coupled to the tank.

502 - 49 RESTRICTED
R. M. S. T. I. FEB. 12, 1945

Fig. 49 Waveforms of grid modulated amplifier.

TRANSMITTER FUNDAMENTALS

FREQUENCY MODULATION

For communication use, frequency modulation (FM) is a process in which the carrier amplitude is constant and the output frequency of the transmitter is made to vary about the carrier or rest frequency at a rate corresponding to the audio frequencies of the modulating signal. The extent to which the frequency changes from the carrier or rest frequency is proportional to the amplitude of the modulating signal.

1. ADVANTAGES:

- (a) Reduction of all types of electrical noise, because these noises are oscillations varying in amplitude.
- (b) Very little AF modulating power is required because there is no power variation in the FM output.
- (c) Greatly reduced interference from stations operating in the same and adjacent channels.

2. LIMITATIONS:

- (a) Relatively wide band of frequencies required.
- (b) In the VHF bands allotted to FM, the transmission range is practically line-of-sight.

3. NAVY USE:

- (a) Short range communication, usually with portable equipment.

4. METHODS OF PRODUCING FM:

- (a) Capacitor microphone.
- (b) Reactance tube.
- (c) Indirect system using phase modulation.

CAPACITOR MICROPHONE SYSTEM OF FM

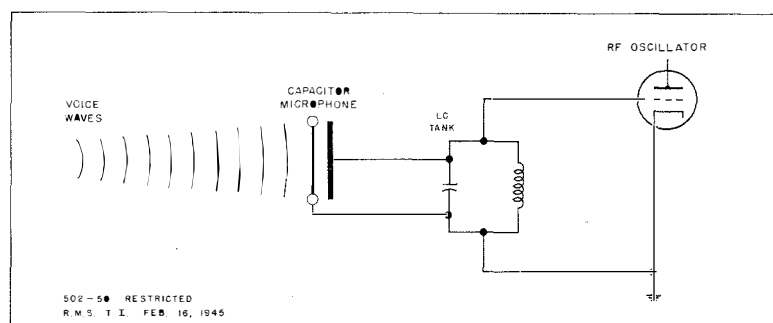

Fig. 50 Capacitor microphone FM oscillator.

Voice waves striking the microphone cause changes in the capacity of the RF tank circuit. The oscillator frequency varies above and below normal at the voice rate, the extent of the frequency change depending on the amplitude of the voice waves.

Although fundamentally the simplest, this method of producing FM is the least practical because of mechanical limitations and non-linearity of modulation.

The three terms used to express the characteristics of an FM wave are:

1. **DEVIATION:** The amount the frequency is varied away from the carrier frequency in one direction.
 - (a) Directly proportional to the amplitude of the modulating voltage.
 - (b) Independent of the frequency of the modulating voltage.
2. **TOTAL SWING:** The sum of the deviation above and below the carrier.
3. **MODULATION INDEX:** A measure of the degree of frequency modulation.
 - (a) The ratio of *deviation* to *modulation frequency*.

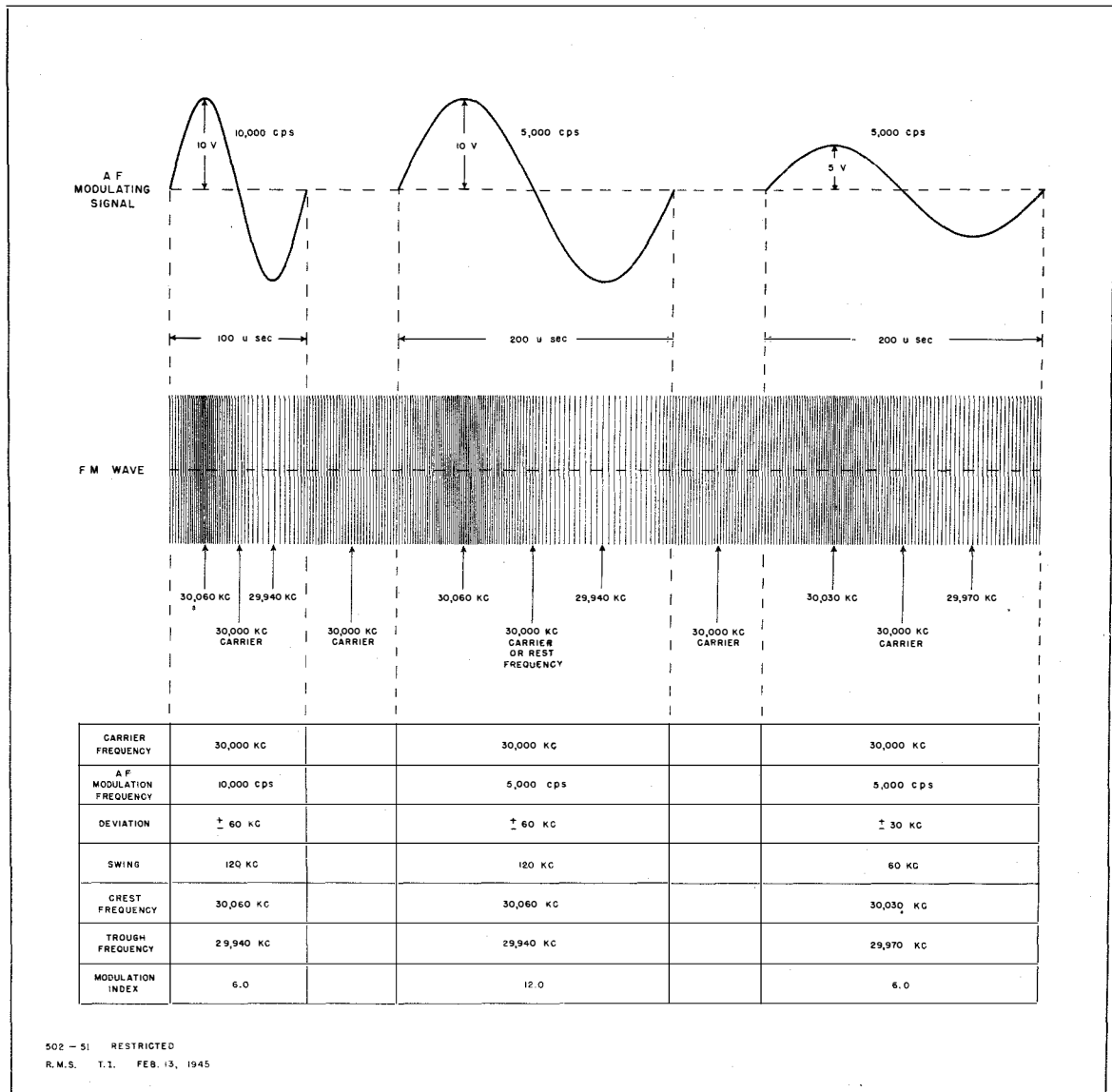

Fig. 51 Relations between an FM wave and the modulating voltage.

TRANSMITTER FUNDAMENTALS

REACTANCE TUBE SYSTEM OF FREQUENCY MODULATION

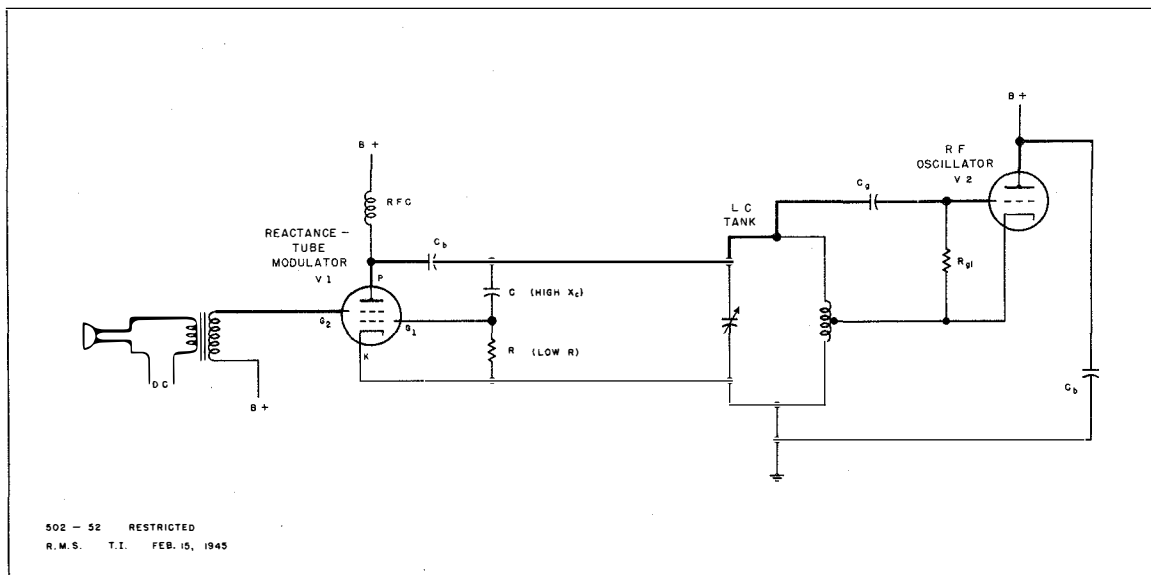

Fig. 52 Reactance tube system of FM.

1. **PURPOSE:** To vary the frequency of the RF oscillator in accordance with the intelligence to be transmitted.
2. **GENERAL CIRCUIT CONDITIONS:**
 - (a) The combination of carbon microphone, tetrode tube and phase shifter in Fig. 52 perform the same function as the capacitor microphone in Fig. 50.
 - (1) The phase shifter network consists of a high X_C and low R to provide practically a full 90-degree phase shift.
3. **OPERATION:**
 - (a) The RF voltage across the LC tank circuit causes a 90-degree leading current to flow in the phase shifter.
 - (b) The RF excitation voltage applied to the control grid (G_1) of the reactance tube (V-1) leads the tank voltage by 90 degrees.
 - (c) The reactance tube plate current is in phase with the 90-degree leading grid voltage, so the effect on the oscillator tank circuit is the same as if the reactance tube were a capacitor connected across the tank.
 - (d) When an AF voltage from the microphone is applied to the screen grid (G_2), the 90-degree leading RF plate current of the reactance tube varies in amplitude at the AF rate. This has the effect of varying the capacitive reactance of the oscillator tank circuit, and therefore causes the RF oscillator frequency to increase and decrease at the AF rate of the microphone signal.
 - (e) This circuit may be converted into an inductive-reactance type rather than a capacitive-reactance type by inverting the RC phase shifter and transposing the relative values of R and X_C .

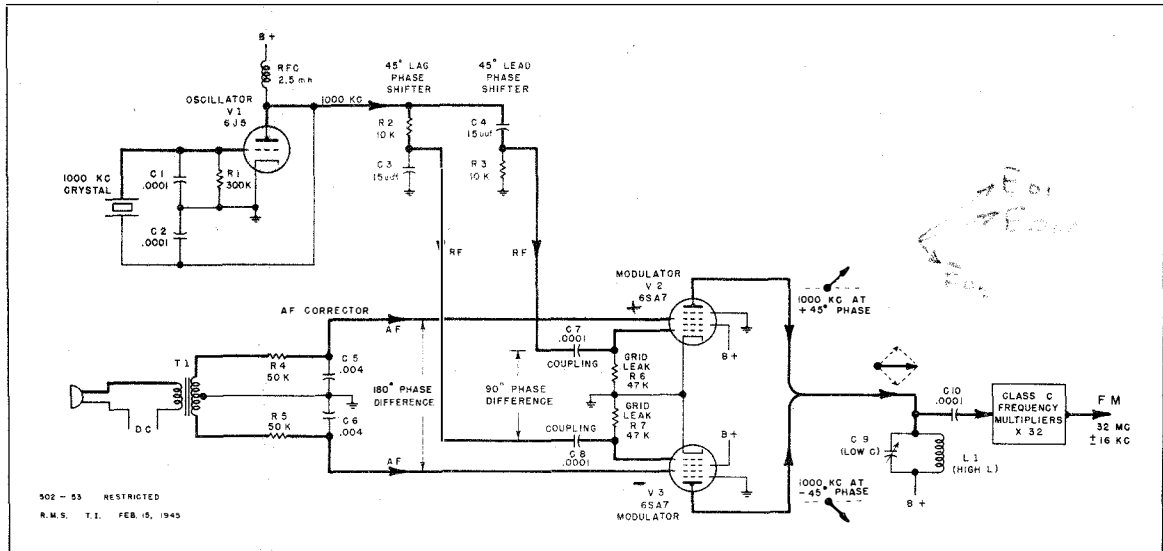
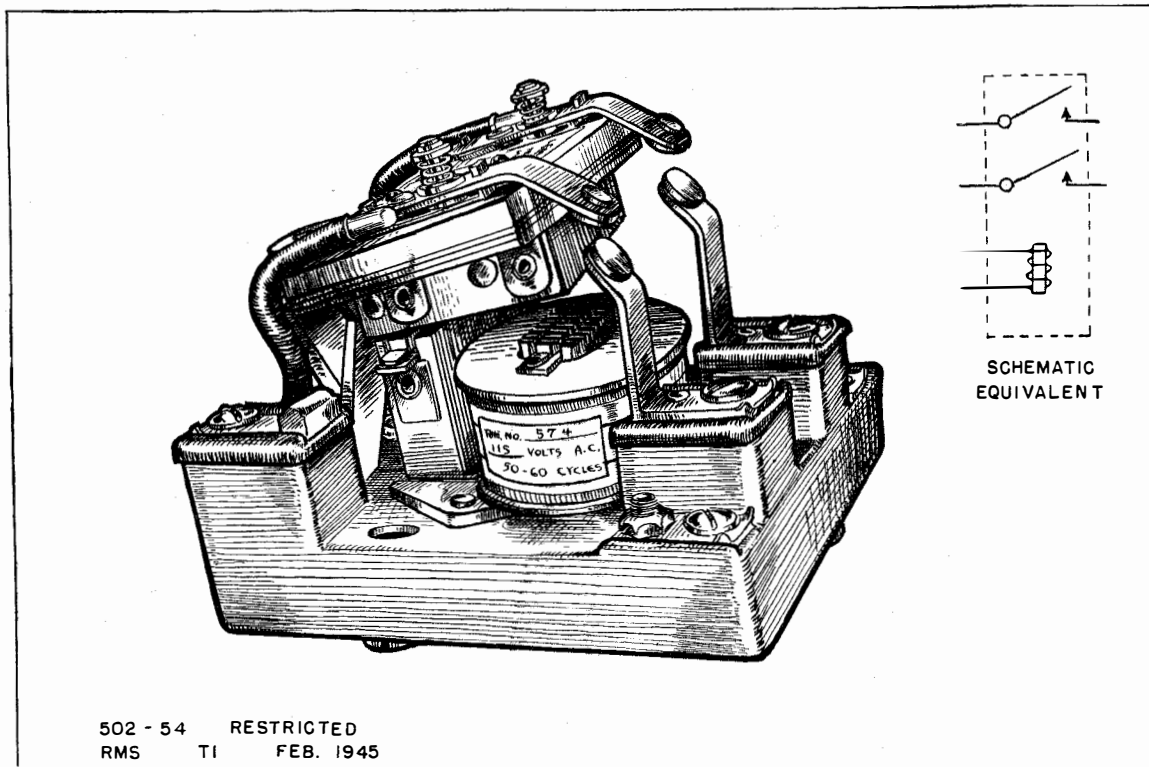

Fig. 53 An indirect system of frequency modulation.

1. PURPOSE: To produce FM by modulating the phase of an RF wave.
2. GENERAL CIRCUIT CONDITIONS:
 - (a) A stable frequency is generated by the crystal oscillator V-1.
 - (b) Phase shifter C4-R3 causes the RF output of V2 to lead by 45 degrees.
 - (c) Phase shifter R2-C3 causes the RF output of V3 to lag by 45 degrees.
 - (d) Audio modulating voltage is applied to the modulator injector grids in push-pull.
 - (e) The modulator plates are connected in parallel.
3. OPERATION:
 - (a) Without modulation, the RF outputs of V-2 and V-3 are of equal magnitude. These two RF signals have a phase difference of 90 degrees, and when combined in the tank L1-C9 produce the rest frequency.
 - (b) On the extreme positive peak of modulation, the output of V-2 is maximum and V-3 is cut off. Using the rest frequency as a reference, the RF output wave is now leading by 45 degrees.
 - (c) On the extreme negative peak of modulation, V-2 is cut off and the output of V-3 is maximum. The RF output wave is now lagging the rest frequency by 45 degrees.
 - (d) With voice modulation, to preserve linearity the phase deviation is limited to ± 30 degrees or less, but the effect is the same.
 - (e) The Class C frequency multiplier stages following the modulator increase the frequency deviation and also act as limiters to remove undesirable amplitude modulation.
4. RESULTS:
 - (a) As the phase of the output wave *moves ahead*, the frequency is higher than the rest frequency.
 - (b) As the phase of the output wave *falls behind*, the frequency is lower than the rest frequency.

TRANSMITTER FUNDAMENTALS

A TYPICAL RELAY OR MAGNETIC CONTACTOR



502 - 54 RESTRICTED
RMS TI FEB. 1945

Fig. 54 AC-DC double pole single throw relay.

1. **PURPOSE:** To open or close electrical circuits by remote control.
2. **GENERAL CONDITIONS:**
 - (a) Contact tips are silver for good conductivity even when oxidized.
 - (b) Tension springs compensate for contact wear and misalignment.
 - (c) Return spring holds contacts *open* when relay coil is *de-energized*. This type of contact is called '*normally open*'.
 - (d) Coil of copper wire mounted on U-shaped iron core forms an electro-magnet for operating the relay. The magnetic strength depends on the ampere-turns.
 - (1) For AC operation, the iron core and armature are laminated to reduce heating from eddy current losses. The current induced in the copper 'shading coils' embedded in the core faces is sufficient to prevent chattering. Current in the operating coil is limited mainly by inductive reactance.
 - (2) The same relay may be operated with DC, either at reduced supply voltage or with a series resistor.
3. **OPERATION:**
 - (a) When the coil circuit is energized, the magnetized core attracts the iron armature and closes the contacts.
 - (b) When the coil is de-energized, the return spring pulls the armature away from the de-magnetized core and opens the contacts.

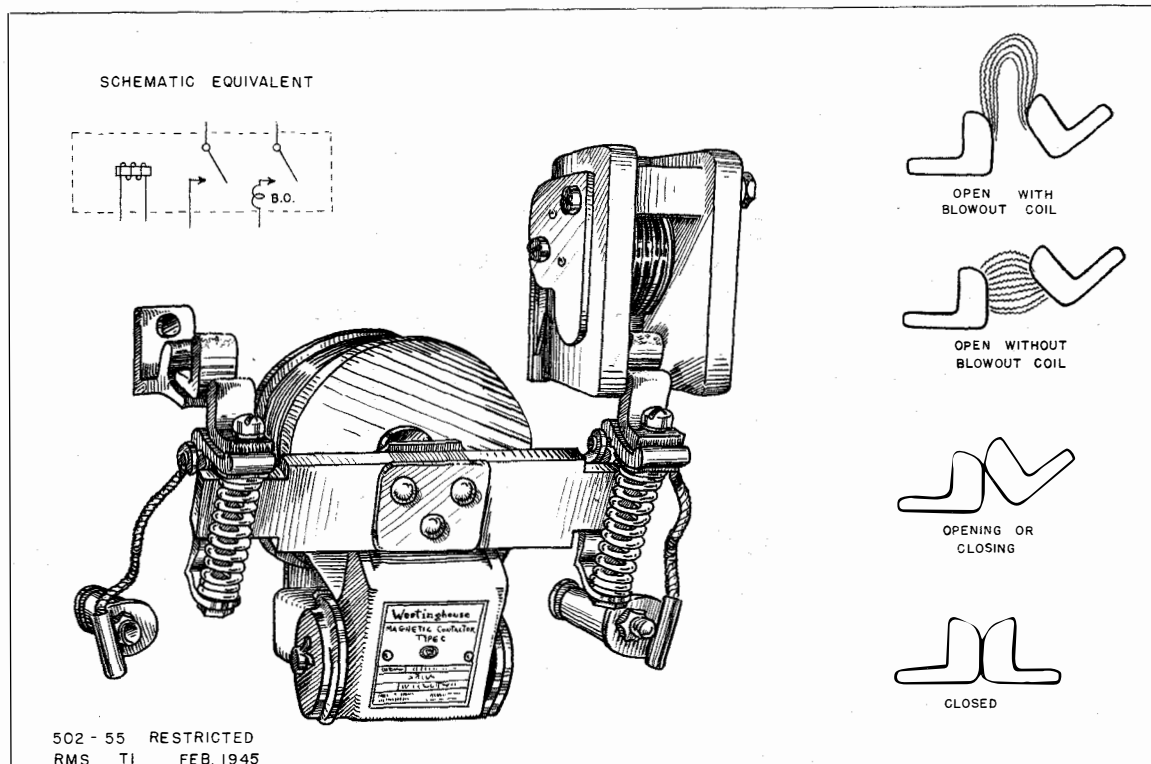
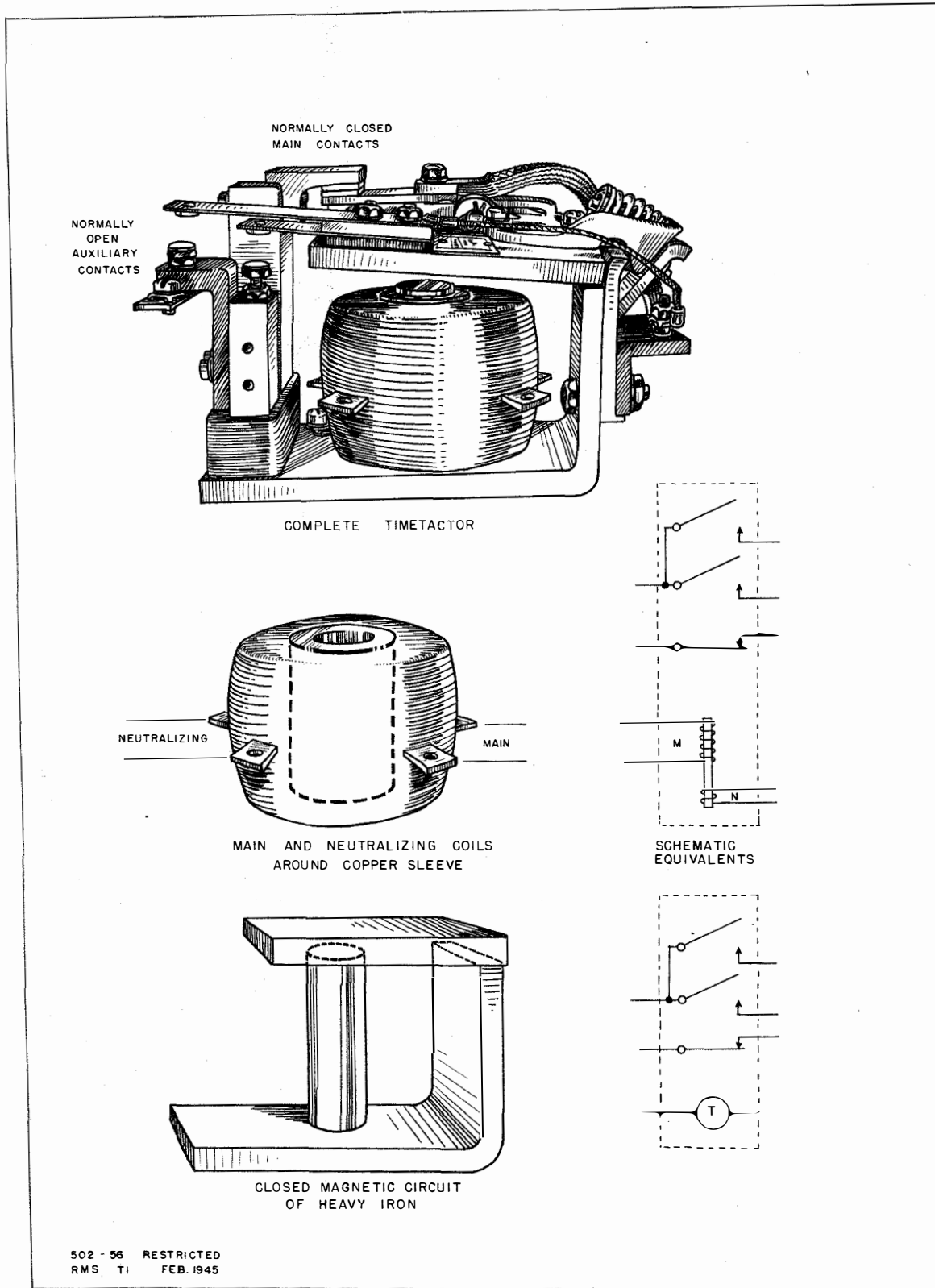

Fig. 55 A typical heavy duty double pole single throw DC relay.

1. **PURPOSE:** To make and break a circuit carrying a heavy DC load.
2. **GENERAL CONDITIONS:**
 - (a) Large operating coil is a strong electromagnet for operating heavy contacts and maintaining firm contact pressure.
 - (b) Solid iron core and armature (laminations are unnecessary for DC).
 - (c) Heavy copper contacts for high amperage are easily replaceable. Curved faces and rolling action prevent sticking and cause make and break to occur only at top of contacts. When completely closed, contact is maintained over a broad area near the bottom.
 - (d) Blowout coil of edgewise-wound heavy copper ribbon carries the entire load current, and provides a strong magnetic field at right angles to the current flow across the contacts for deflecting the arc upward. Iron plates on arc barriers extend magnetic field to the contacts.
3. **OPERATION:**
 - (a) When the operating coil is energized, the magnetized core attracts the iron armature and closes the contacts.
 - (b) When the operating coil is de-energized, the heavy tension springs and return spring open the contacts with a rolling action so the break will occur at the top of the contacts.
 - (c) The large arc formed when the high amperage DC circuit is being broken is deflected upward by the magnetic field of the blowout coil. This lengthens, cools and quickly extinguishes the arc, minimizing the burning and confining the damage to the top of the contacts.

TRANSMITTER FUNDAMENTALS



502 - 56 RESTRICTED
RMS TI FEB. 1945

Fig. 56 Timetactor time delay relay.

1. **PURPOSE:** To provide a time delay between the removal of a control voltage and the operation of the relay contacts. A Timetactor is commonly used in a DC motor starter, to short out starting resistance after the motor gains speed. Any relay used in this manner may be called an accelerating relay.
2. **GENERAL CONDITIONS:**
 - (a) The main contacts are broad and heavy, with silver faces. They must short out the starting resistance and carry the motor armature current, but require no arc protection because they never open under load. These are *normally closed* contacts (held closed by the return spring when the coil is de-energized).
 - (b) The auxiliary contacts are both *normally open*. One pair controls the main line contactor, and the other controls the neutralizing circuit of the Timetactor.
 - (c) The main coil corresponds to the operating coil of an ordinary relay. When energized from the DC line, this coil magnetizes the iron core, attracts the armature and operates the contacts (in this case opens the main contacts and closes both pairs of auxiliary contacts).
 - (d) The thick copper sleeve extending through the center of the coil is a closed electrical circuit of very low resistance.
 - (e) When the main coil is de-energized, the magnetic field intensity begins to decrease, but even a slight change in field intensity induces sufficient current in the copper sleeve to sustain most of the original magnetic field. By delaying the loss of the magnetic field, the copper sleeve delays the return of the relay armature to the normal (de-energized) position.
 - (f) The iron core, armature and mounting bracket all are made unusually heavy to provide a closed magnetic circuit of very low reluctance as long as the armature is touching the face of the core.
 - (g) The electrical and magnetic losses are so small that unless the core is intentionally de-magnetized it will not release the relay armature for several hours after the main coil is de-energized.
 - (h) The time delay is shortened to the desired length by passing a small amount of DC through the neutralizing coil in a direction opposite to that of the original magnetizing current in the main coil. The time delay may be adjusted over a useable range of 1/2 to 6 seconds by controlling the neutralizing current.
3. **TYPICAL OPERATION OF A TIMETACTOR IN A DC MOTOR STARTER:** The normally closed main contacts are connected across the starting resistance. Therefore the manual start switch must energize the Timetactor to open these contacts before the motor is turned on. One pair of Timetactor auxiliary contacts energizes the main line contactor to start the motor. The other pair energizes the neutralizing coil. After a delay sufficient for the motor to accelerate, the Timetactor releases. The main contacts close and short out the starting resistance. The auxiliary contacts open, ready for the next start. The main line contactor has holding contacts to keep its coil energized after the Timetactor releases.

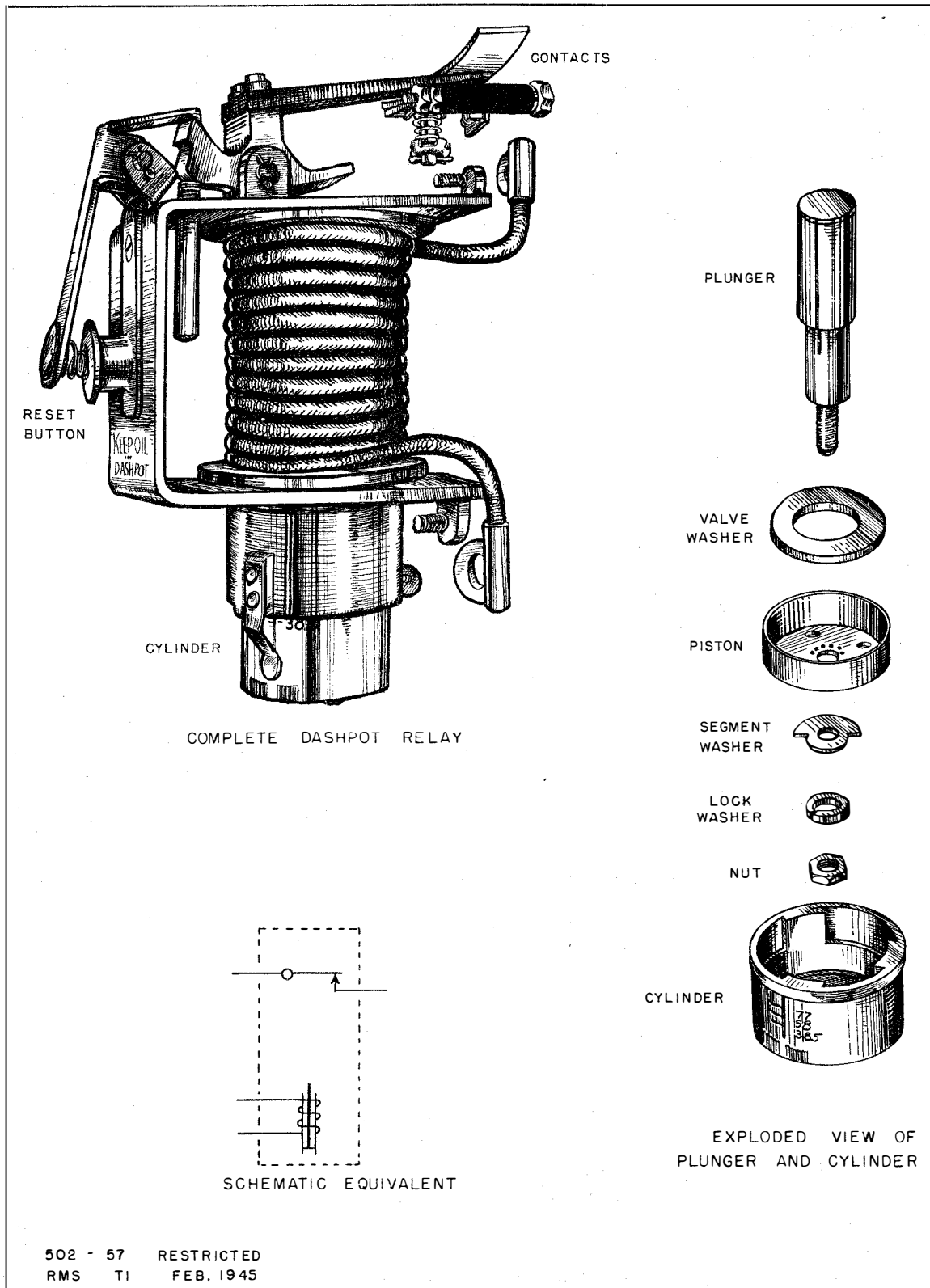

Fig. 57 Typical dashpot type time delay relay.

1. **PURPOSE:** To provide a time delay between the energizing of the relay coil and the operation of the contacts. Dashpot relays are particularly suitable for overload protection because for any given setting, the actual delay varies inversely with the amount of overload.
2. **GENERAL CONDITIONS:**
 - (a) The complete dashpot relay is shown in the tripped position, with the normally closed contacts mechanically latched open.
 - (b) The contacts are intended to break only small currents: If the circuit to be protected carries high amperage, the dashpot relay contacts may control the coil circuit of a heavy duty relay such as the one shown in Fig. 55.
 - (c) The operating coil is a hollow solenoid into which the dashpot plunger may be lifted by the magnetic field. The coil in Fig. 57 has relatively few turns of heavy wire, and is intended to carry from 38.5 to 77 amperes. This relay is suitable for overload protection of a 5-hp, 115-volt DC motor. If the operating coil had several hundred turns of fine wire, a fraction of an ampere would operate the relay, making it suitable for overload protection of a vacuum tube.
3. **OPERATION:**
 - (a) As long as current in the operating coil does not exceed the value of the dashpot setting, the plunger assembly rests on the bottom of the cylinder.
 - (b) When current flow exceeds the setting, the magnetic field intensity is sufficient to lift the plunger assembly. However, the upward travel is retarded by the slow transfer of oil through the small holes near the center of the piston.
 - (1) If the current flow returns to normal before the piston reaches the three by-pass channels in the cylinder wall, the plunger falls back down without operating the contacts.
 - (2) If the overload continues, the plunger rises slowly until the oil can pass freely around the piston through the by-pass channels in the cylinder wall. Then the plunger jumps to the top of its travel and opens the contacts.
 - (c) When the overloaded circuit is broken, current no longer flows in the dashpot operating coil. As the plunger moves downward, oil lifts the loose valve washer off the large holes in the piston, allowing the entire plunger assembly to drop quickly to the bottom of the cylinder.
 - (d) The contacts remain latched open until the reset button is pressed.
4. **CURRENT ADJUSTMENT:** The magnetic field intensity required to lift the iron plunger depends on the vertical position of the plunger within the coil. To increase the current setting, the dashpot cylinder is screwed downward in the mounting, lowering the entire dashpot assembly.
5. **TIME ADJUSTMENT:** To lengthen the time delay, the segment washer is set to cover more of the small holes in the bottom of the piston.

