

UNCLASSIFIED

NAVSHIPS 0967-031-9010

TECHNICAL MANUAL

for

TRANSMITTER
GROUP
AN/WRA-3

DEPARTMENT OF THE NAVY

BUREAU OF SHIPS

UNCLASSIFIED

Approved: 23 July 1965

LIST OF EFFECTIVE PAGES

PAGE NUMBERS	CHANGE IN EFFECT	PAGE NUMBERS	CHANGE IN EFFECT
Title Page	Original	4-1 to 4-24	Original
ii to vii	Original	5-1 to 5-36	Original
1-0 to 1-6	Original	6-1 to 6-43	Original
2-1 to 2-16	Original	i-0 to i-2	Original
3-1 to 3-20	Original		

HOFFMAN ELECTRONICS CORPORATION, MILITARY PRODUCTS DIVISION
 HOFFMAN ELECTRONIC PARK, EL MONTE, CALIFORNIA Contract: NObsr-91345

Errors found in this publication (other than obvious typographical errors), which have not been corrected by means of Temporary Corrections or Permanent Changes should be reported. Such report should include the complete title of the publication and the publication number (short title); identify the page and line or figure and location of the error; and be forwarded to the Electronics Publications Section of the Bureau of Ships.

All Navy requests for NAVSHIPS electronics publications listed in the current issue of NAVSANDA Publication 2002 "Requisitioning Guide and Index of Forms and Publications", Cognizance Symbol I, or in a subsequent issue of the Electronics Information Bulletin should be directed to the appropriate Forms and Publications Supply Point.

NOTE

Transmitter Group AN/WRA-3 is designed to operate from either a 115 or 230 volt, 60 cycle, single phase primary power source.

As shipped from the factory, the AN/WRA-3 is internally connected for operation from a 115 volt, 60 cycle, single phase primary power source. Refer to Technical Manual NAVSHIPS 0967-031-9010, para. 2-4c, for instructions if operation from 230 volt, 60 cycle, single phase power is required.

In addition, the AN/WRA-3 is internally connected for the emergency substitution of Electrical Frequency Synthesizer O-1115/URC operating from a 115 volt, 400 cycle, single phase primary power source. Refer to Technical Manual NAVSHIPS 0967-031-9010, para. 2-8, steps 6 through 10, for information on the additional 115 volt, 400 cycle, single phase primary power source connections required, or para. 2-9 for procedure to reconnect internal wiring to use a synthesizer operating from 115 volt, 60 cycle, single phase power.



-

-

1



.

.



Temporary Change 1 to Technical Manual for Transmitter Group AN/WRA-3

This temporary change corrects minor errors and omissions in the Technical Manual published under Contract NObsr-91345, and is in effect immediately upon receipt.

Maintenance support activities shall insert this change in the technical manual immediately behind the front cover.

1. No pages of the technical manual are superseded by this temporary change.
2. Make the following pen-and-ink changes, and mark "TC ~~CHG~~ 1" adjacent to the pen-and-ink changes.

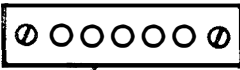
First Issued In	Page No.	Chg In Effect	Table, Col, Para, or Figure	Line or Location	Action
Orig	1-4	Orig	Table 1-1	Second column, line 35	CHANGE: "URC (GFM)" to "URC (GFM)****"
Orig	2-11	Orig	Figure 2-7	Below illustration J 6 J10	ADD: "**In some units input power is applied to TB1 instead of J6." CHANGE: "J6" to "J6*" ADD: <div style="text-align: center;">  <p>(TB1)*</p> </div> about 3/8 inch left of connector J10 and 3/8 inch above bottom edge of panel.

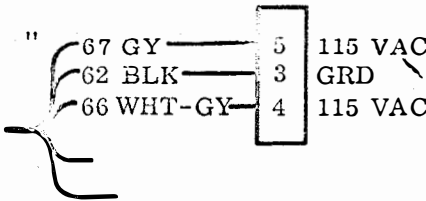
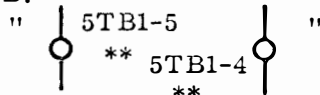
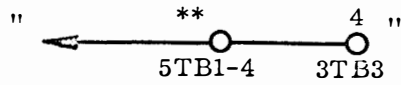
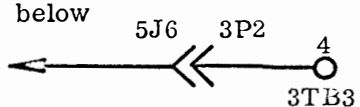
First Issued In	Page No.	Chg In Effect	Table, Col, Para, or Figure	Line or Location	Action
Orig	2-15	Orig	Figure 2-10	Top right corner of diagram	<p>ADD: 5TB1</p>  <p>ALTERNATE POWER CONNECTIONS FOR O-1115/URC UNITS USING TERMINAL BOARD TB1 INSTEAD OF CONNECTOR J6 (3P22 NOT USED)."</p>
Orig	4-23	Orig	Figure 4-5	Left center	CHANGE: Diode 2CR1 from "1N3031B" to "1N3035B"
Orig	5-13	Orig	Figures 5-8 and 5-9	Top photo (top view)	DELETE: "+7.6VDC" shown marked adjacent to test point J2 in figures 5-8 and 5-9. (2 places)
Orig	5-25	Orig	Figure 5-13	Upper right corner (inside dashed line box) Right side of motor circuit	<p>ADD:</p>  <p>adjacent to connectors 5J6A and 5J6C.</p> <p>ADD:</p>  <p>below</p> 

First Issued In	Page No.	Chg In Effect	Table, Col, Para, or Figure	Line or Location	Action
Orig	6-22	Orig	Table 6-2	2CR1	CHANGE: MIL-type "IN3031B" to "IN3035B"
Orig	6-31	Orig	Table 6-2	2A4R3	CHANGE: MIL-type "RC42GF820K" to "RW67V820"
				2A4R5	CHANGE: MIL-type "RC32GF223K" to "RC32GF822K"
Orig	6-34	Orig	Table 6-2	2CR1	CHANGE: MIL-type "IN3031B" to "IN3035B"
Orig	6-35	Orig	Table 6-2	3F1	DELETE: "MS90079-25-1" and "MS90078-15-1" CHANGE: MIL-type "FO3G12R0B" to "FO3A250V12AS" CHANGE: MIL-type "FO3G6R00A" to "FO2A250V6AS"

TABLE OF CONTENTS

Paragraph	Page	Paragraph	Page		
SECTION 1- GENERAL INFORMATION		SECTION 1- GENERAL INFORMATION (Cont)			
1-1.	Scope	1-1	1-7.	Factory or Field Changes . . .	1-3
1-2.	General Description	1-1	1-8.	Equipment Similarities	1-3
1-3.	Description of Units	1-1	1-9.	Preparation for Reshipment . .	1-3
	a. General	1-1	SECTION 2 - INSTALLATION		
	b. Electrical Equipment Cabinet		2-1.	Unpacking and Handling	2-1
	CY-3022/WRA-3	1-1	2-2.	Power Requirements and	
	c. Electrical Frequency		Distribution	2-1	
	Synthesizer O-1115/		2-3.	Installation Layout	2-1
	URC(GFM)	1-1	2-4.	Installation Requirements . . .	2-1
	d. Interconnecting Unit		a. General	2-1	
	MX-3645/WRA-3	1-1	b. Dismantling	2-1	
	e. Radio Frequency Amplifier		(1) Removal of Power		
	AM-2819/WRA-3	1-1	Supply		
	f. Power Supply		PP-2796/WRA-3	2-1	
	PP-2796/WRA-3	1-2	(2) Removal of Radio Fre-		
	g. Resilient Mount		quency Amplifier		
	MT-2661/WRA-3	1-2	AM-2819/WRA-3	2-3	
	h. Relay Assembly		(3) Removal of Interconnect-		
	RE-754/WRT-4	1-2	ing Unit		
	i. Modification Kit		MX-3645/WRA-3	2-3	
	MK-846/WRA-3	1-2	(4) Removal of Electrical		
1-4.	Reference Data	1-2	Frequency Synthe-		
	a. Frequency Range	1-2	sizer O-1115/URC	2-4	
	(1) Electrical Frequency		(5) Disassembly of Elec-		
	Synthesizer		trical Equipment		
	O-1115/URC(GFM)	1-2	Cabinet		
	(2) Radio Frequency Ampli-		CY-3022/WRA-3	2-4	
	fier AM-2819/WRA-3	1-2	c. Reassembly and		
	b. Type of Frequency Control . .	1-2	Connections	2-4	
	(1) Electrical Frequency		d. Outline Drawing	2-4	
	Synthesizer		e. Interconnection	2-4	
	O-1115/URC(GFM)	1-2	(1) Radio Set AN/URC-32 . .	2-4	
	(2) Radio Frequency Ampli-		(2) Radio Transmitting Set		
	fier AM-2819/WRA-3	1-2	AN/WRT-2	2-4	
	c. Type of Emission and Modu-		2-5.	Cable Assemblies	2-8
	lation Characteristics	1-2	2-6.	Inspection and Adjustment . . .	2-8
	d. Power Output	1-2	a. General Inspection	2-8	
	(1) For Direct Transmission .	1-2	b. Energizing the Equipment		
	(2) For Excitation	1-2	for the First Time	2-9	
	e. Frequency Stability	1-2	c. Installation Adjustments . .	2-11	
	f. Electrical Input and Output		d. Checking Performance	2-11	
	Data	1-2	2-7.	Interference Reduction	2-13
	(1) Electrical Frequency		2-8.	Emergency Use of Synthesizer	
	Synthesizer		Operating with 115 Volt 400		
	O-1115/URC(GFM)	1-2	cps Power Input	2-13	
	(2) Radio Frequency Ampli-		2-9.	Returning Equipment to Normal	
	fier AM-2819/WRA-3	1-2	Configuration After Emer-		
	g. Characteristics of		gency Use of Synthesizer . . .	2-14	
	Recommended Antennas	1-3	SECTION 3 - OPERATION		
	h. Ambient Temperature		3-1.	Functional Operation	3-1
	Limitations	1-3	3-2.	Operating Procedures	3-1
	i. Characteristics of Power		a. Description of Controls	3-1	
	Supply PP-2796/WRA-3	1-3			
1-5.	Equipment Supplied	1-3			
1-6.	Equipment and Publications				
	Required But Not Supplied . . .	1-3			

TABLE OF CONTENTS (Cont)

Paragraph	Page	Paragraph	Page
SECTION 3 - OPERATION (Cont)		SECTION 4 - TROUBLE SHOOTING (Cont)	
3-2.	3-1	a.	4-1
b.	3-1	b.	4-1
(1)	3-1	c.	4-1
(a)	3-1	Function	
(b)	3-1	d.	4-1
1.	3-1	Function	
mission (15		e.	4-1
Watts Power		Circuit	
Output)	3-1	f.	4-1
2.	3-1	Failure Analysis	
Excitation (for		4-2.	4-1
Larger		Over-All Functional	
Equipment)	3-1	Description	
(c)	3-2	4-3.	4-3
Starting Transmitter		Functional Section	
Group AN/WRA-3	3-2	Description	
(d)	3-7	a.	4-3
Starting Radio Trans-		Over-All Functional	
mitting Set		Section Description	
AN/WRT-2	3-7	b.	4-4
(e)	3-7	Functional Section Isola-	
Starting Radio Set		tion Procedure	
AN/URC-32	3-7	c.	4-5
(2)	3-7	Synthesizer Functional	
During Use		Section Description	
(a)	3-7	d.	4-5
Adjustments for		Synthesizer Functional	
Electrical Fre-		Section Test Data	
quency Synthesizer		(1) Control Settings	4-5
O-1115/URC	3-7	(2) Test Equipment and	
(b)	3-8	Special Tools	4-5
Adjustments for		(3) Performance	
Radio Transmitting		Indicators	4-5
Set AN/WRT-2	3-8	(4) Test Points	4-5
(c)	3-9	(5) Test	4-6
Adjustments for		e.	4-6
Radio Set		Power Supply Functional	
AN/URC-32	3-9	Description	
(3)	3-10	(1) +300 Volt DC Power	
Standby		Supply 2A1	4-6
(4)	3-10	(2) +950 Volt DC Power	
Secure		Supply 2A2	4-6
(a)	3-10	(3) Bias Power Supply 2A3	4-6
Transmitter Group		(4) 144 Volt (RMS) 400	
AN/WRA-3	3-10	Cycle Power Supply	
(b)	3-10	2A4	4-6
Radio Transmitting		(5) 28 Volt Power Supplies	
Set AN/WRT-2	3-10	2A5 and 2A6	4-6
(c)	3-10	f.	4-7
Radio Set AN/URC-32		Power Supply Functional	
3-3.	3-10	Section Test Data	
Summary of Operating		(1) Control Settings	4-7
Procedures	3-10	(2) Test Equipment and	
3-4.	3-10	Special Tools	4-7
Emergency Operation		(3) Test Points	4-7
3-5.	3-10	(4) Test	4-7
Operator's Maintenance		g.	4-9
a.	3-10	Radio Frequency Ampli-	
Operating Checks and		fier Functional Section	
Adjustments	3-10	Description	
b.	3-11	(1) Balanced Modulator	4-9
Emergency Maintenance		(2) Driver and Power	
(1)	3-11	Amplifiers	4-10
Replacing Indicator		(3) Controls and Indicators	4-10
Lamps	3-11	h.	4-14
(2)	3-11	Radio Frequency Ampli-	
Replacing Fuses		fier Functional Section	
(3)	3-11	Test Data	
Replacing Vacuum Tubes			
(a)	3-11		
Symptoms of Tube			
Failure	3-11		
(b)	3-11		
Power Amplifier			
Tube	3-11		
c.	3-11		
Routine Check Charts			
SECTION 4 - TROUBLE SHOOTING			
4-1.	4-1		
Logical Trouble Shooting			

TABLE OF CONTENTS (Cont)

Paragraph	Page	Paragraph	Page
SECTION 4 - TROUBLE SHOOTING (Cont)		SECTION 5- MAINTENANCE (Cont)	
4-3.	(1) Control Settings 4-14	5-3.	d. Instructions 5-1
	(2) Test Equipment and Special Tools 4-14		(1) Adjustment of Power Supply PP-2796/ WRA-3 5-1
	(3) Performance Indicators 4-14		(a) Plate Overload Relay Current Adjustment 5-2
	(4) Test Points 4-14		(b) Bias Power Supply 2A3, Output Adjustment 5-2
	(5) Tests 4-14		(c) +28 Volt DC Power Supply 2A6, Volt- age Output Adjustment 5-2
	i. Miscellaneous Trouble- Shooting Data 4-15		(d) -28 Volt DC Power Supply 2A5, Volt- age Output Adjustment 5-2
	(1) Control and Power Circuits 4-15		(e) 144 Volt (RMS) 400 cps Power Supply 2A4, Frequency Output Adjustment 5-2
	(a) Turn-On Sequence 4-15		(2) Adjustment of Radio Frequency Amplifier AM-2819/WRA-3 5-3
	(b) Protective Circuits 4-15		(a) Driver Amplifier Alignment 5-4
	(c) Keying Relay 4-15		(b) Modulator Balancing Adjustment 5-5
	(d) Direct Transmis- sion Application 4-16		(c) Amplifier Neutralization 5-8
	(e) Exciter Application 4-16	5-4.	Repair 5-10
	(2) Interconnecting Unit MX-3645/WRA-3 4-16		a. Removal, Repair and Replacement of Parts 5-10
	(3) Electrical Equipment Cabinet CY-3022/ WRA-3 4-16		b. Removal of Parts in Radio Frequency Amplifier AM-2819/WRA-3 5-10
	(4) Relay Assembly RE-754/WRT-4 4-16		(1) Removal and Replace- ment of Power Ampli- fier Tube 1V5 5-11
	(5) Resilient Mount MT-2661/WRA-3 4-16		(2) Removal and Replace- ment of Blower Motor 1B1 5-12
	j. Miscellaneous Test Data 4-16		(3) Removal and Replace- ment of Parts in the Balanced Modulator Driver Amplifier Stages 5-12
	(1) Control Setting 4-16		(4) Removal of Tuning Chassis 5-12
	(2) Test Equipment and Special Tools 4-16		(5) Installation of Tuning Chassis 5-17
	(3) Test Points 4-16		c. Removal of Parts in Power Supply PP-2796/ WRA-3 5-19
	(4) Test 4-16		
	(a) Control/Power and Protective Circuits 4-16		
	(b) Interconnecting Unit MX-3645/WRA-3 4-16		
	(c) Electrical Equip- ment Cabinet CY-3022/WRA-3 4-16		
	(d) Relay Assembly RE-754/WRT-4 4-16		
	(e) Resilient Mount MT-2661/WRA-3 4-16		
SECTION 5 - MAINTENANCE			
5-1.	Failure, and Performance and Operational Reports 5-1		
5-2.	Preventive Maintenance 5-1		
5-3.	Tuning and Adjustment 5-1		
	a. General 5-1		
	b. Test Equipment and Special Tools 5-1		
	c. Control Settings 5-1		

TABLE OF CONTENTS (Cont)

Paragraph	Page	Paragraph	Page
SECTION 5 - MAINTENANCE (Cont)		SECTION 6 - PARTS LIST	
5-4. d. Removal of Parts in Electrical Equipment Cabinet CY-3022/WRA-3	5-19	6-1. Introduction	6-1
e. Removal of Parts in Interconnecting Unit MX-3645/WRA-3	5-19	6-2. List of Major Units	6-1
		6-3. Maintenance Parts List	6-1
		6-4. List of Manufacturers	6-1
		6-5. Notes	6-1

LIST OF ILLUSTRATIONS

Figure	Page	Figure	Page
SECTION 1 - GENERAL INFORMATION		SECTION 3 - OPERATION (Cont)	
1-1. Transmitter Group AN/WRA-3	1-0	3-4. Electrical Equipment Cabinet CY-3022/WRA-3, Unit 3, Front Panel Controls and Indicators	3-5
SECTION 2 - INSTALLATION		3-5. Radio Frequency Amplifier AM-2819/WRA-3, Unit 1, Top View	3-6
2-1. Transmitter Group AN/WRA-3, Dimensional Outline Drawing	2-2	SECTION 4- TROUBLE SHOOTING	
2-2. Transmitter Group AN/WRA-3, Dismantling Diagram	2-5	4-1. Transmitter Group AN/WRA-3, Over-All Functional Block Diagram	4-2
2-3. Power Supply PP-2796/WRA-3, Unit 2, Drawer Slide Installation	2-7	4-2. Power Supply PP-2796/WRA-3, Unit 2, Functional Section Servicing Block Diagram	4-11
2-4. Power Supply PP-2796/WRA-3, Unit 2, Bottom View	2-8	4-3. Radio Frequency Amplifier AM-2819/WRA-3, Unit 1, Functional Section Servicing Block Diagram	4-17
2-5. Radio Frequency Amplifier AM-2819/WRA-3, Unit 1, Bottom View	2-9	4-4. Radio Frequency Amplifier AM-2819/WRA-3, Unit 1, Simplified Schematic Diagram	4-19
2-6. Interconnecting Unit MX-3645/WRA-3, Unit 4, Top View	2-10	4-5. Transmitter Group AN/WRA-3, Control and Power Circuits Diagram	4-21
2-7. Electrical Frequency Synthesizer O-1115/URC, Unit 5, Rear View	2-11	SECTION 5 - MAINTENANCE	
2-8. Electrical Equipment Cabinet CY-3022/WRA-3, Unit 3, External Cable Connector Compartment	2-12	5-1. Power Supply PP-2796/WRA-3, Unit 2, Top View, Assembly and Adjustment Locations	5-3
2-9. Electrical Equipment Cabinet CY-3022/WRA-3, Unit 3, Base Compartment	2-13	5-2. Radio Frequency Amplifier AM-2819/WRA-3, Unit 1, Adjustment Locations	5-4
2-10. Transmitter Group AN/WRA-3, Interconnecting Cabling Diagram	2-15	5-3. Power Supply PP-2796/WRA-3, Unit 2, Test Points and Parts Location	5-5
SECTION 3 - OPERATION		5-4. +300 Volt DC Power Supply, Assembly 2A1, Test Points and Parts Location	5-8
3-1. Electrical Frequency Synthesizer O-1115/URC, Unit 5, Front Panel Controls and Indicators	3-2	5-5. +950 Volt DC Power Supply, Assembly 2A2, Test Points and Parts Location	5-9
3-2. Radio Frequency Amplifier AM-2819/WRA-3, Unit 1, Front Panel Controls and Indicators	3-3		
3-3. Power Supply PP-2796/WRA-3, Unit 2, Front Panel Controls and Indicators	3-4		

LIST OF ILLUSTRATIONS (Cont)

Figure	Page	Figure	Page
SECTION 5 - MAINTENANCE (Cont)		SECTION 5 - MAINTENANCE (Cont)	
5-6.	Bias Power Supply, Assembly 2A3, Test Points and Parts Location 5-10	5-12.	Test Points and Parts Location. Interconnecting Unit MX-3645/WRA-3, Unit 4, Test Points and Parts Location 5-21
5-7.	144 Volt (RMS), 400 cps Power Supply, Assembly 2A4, Test Points and Parts Location 5-11	5-13.	Transmitter Group AN/WRA-3, Primary Power Distribution . . . 5-25
5-8.	-28 Volt DC Power Supply, Assembly 2A5, Test Points and Parts Location 5-13	5-14.	Electrical Equipment Cabinet CY-3022/WRA-3, Schematic Diagram 5-27
5-9.	+28 Volt DC Power Supply, Assembly 2A6, Test Points and Parts Location 5-13	5-15.	Interconnecting Unit MX-3645/WRA-3, Unit 4, Schematic Diagram 5-29
5-10.	Radio Frequency Amplifier AM-2819/WRA-3, Unit 1, Test Points and Parts Location 5-14	5-16.	Radio Frequency Amplifier AM-2819/WRA-3, Unit 1, Schematic Diagram 5-31
5-11.	Electrical Equipment Cabinet CY-3022/WRA-3, Unit 3,	5-17.	Power Supply PP-2796/WRA-3, Unit 2, Schematic Diagram . . . 5-33
		5-18.	Relay Assembly RE-754/WRT-4, Schematic Diagram 5-35

LIST OF TABLES

Table	Page	Table	Page
SECTION 1 - GENERAL INFORMATION		SECTION 4 - TROUBLE SHOOTING (Cont)	
1-1.	Equipment Supplied 1-4	4-2.	Typical Meter Indications 4-13
1-2.	Equipment and Publications Required But Not Supplied 1-5	SECTION 5 - MAINTENANCE	
SECTION 3 - OPERATION		5-1.	Transmitter Group AN/WRA-3, Initial Control Settings for Maintenance 5-22
3-1.	Electrical Frequency Synthesizer O-1115/URC Operating Controls and Indicators 3-12	5-2.	Transmitter Group AN/WRA-3, Test Equipment Required for Maintenance 5-22
3-2.	Radio Frequency Amplifier AM-2819/WRA-3, Operating Controls and Indicators 3-13	5-3.	Radio Frequency Amplifier AM-2819/WRA-3, Control Settings and Adjustments for Driver Amplifier Alignment 5-23
3-3.	Power Supply PP-2796/WRA-3 Operating Controls and Indicators 3-14	SECTION 6 - PARTS LIST	
3-4.	Electrical Equipment Cabinet CY-3022/WRA-3 Operating Controls and Indicators 3-15	6-1.	Transmitter Group AN/WRA-3, List of Units and Assemblies . . . 6-2
3-5.	Summary of Operating Procedures 3-16	6-2.	Transmitter Group AN/WRA-3 Maintenance Parts List 6-3
SECTION 4 - TROUBLE SHOOTING		6-3.	Modification Kit MK-846/WRA-3 Maintenance Parts List 6-39
4-1.	Transmitter Group AN/WRA-3 Preliminary Control Settings for Trouble Shooting 4-4	6-4.	Transmitter Group AN/WRA-3, List of Manufacturers 6-42

Figure
1-1

NAVSHIPS 0967-031-9010

AN/WRA-3
GENERAL INFORMATION

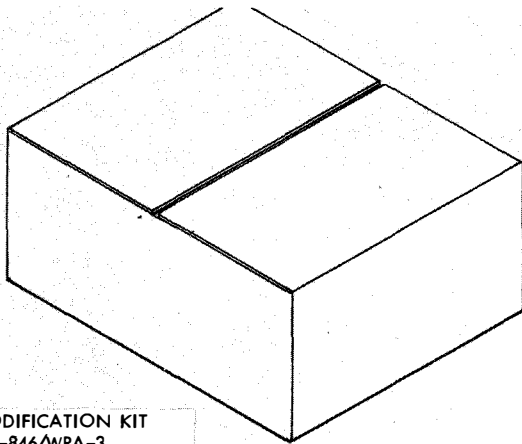

MODIFICATION KIT
MK-846/WRA-3
(INCLUDES TRANSMITTER
TRANSFER CONTROL
C-6562/WRA-3)

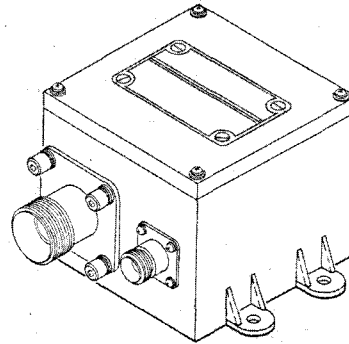

RELAY ASSEMBLY
RE-754/WRT-4
UNIT 7

ELECTRICAL
FREQUENCY
SYNTHESIZER
0-1115/URC
UNIT 5 (GFM)

P/O RESILIENT
MOUNT
MT-2661, UNIT 8

RADIO
FREQUENCY
AMPLIFIER
AM-2819/WRA-3,
UNIT 1

INTERCONNECTING
UNIT MX-3645/WRA-3,
UNIT 4

ELECTRICAL
EQUIPMENT
CABINET
CY-3022/WRA-3,
UNIT 3

POWER SUPPLY
PP-2796/WRA-3,
UNIT 2

P/O RESILIENT
MOUNT
MT-2661, UNIT 8

657-1

Figure 1-1. Transmitter Group AN/WRA-3

1-0

ORIGINAL

SECTION 1

GENERAL INFORMATION

1-1. SCOPE

a. This Technical Manual is in effect upon receipt. When superseded by a later edition, this publication should be destroyed. Extracts from this publication may be made to facilitate the preparation of other Department of Defense publications.

b. The contents of this Technical Manual consists of General Information, Installation, Operation, Trouble Shooting, and Maintenance data, plus a parts list, for Transmitter Group AN/WRA-3. Figure 1-1 is an illustration of the equipment described in this Technical Manual.

1-2. GENERAL DESCRIPTION.

Transmitter Group AN/WRA-3 is a continuous wave (cw) transmitter, designed for installation aboard surface and undersurface vessels.

This equipment is primarily intended for use as an exciter for larger transmitting equipment, such as Radio Set AN/URC-32 or Radio Transmitting Set AN/WRT-2. However, it may also be used independently when coupled to an antenna system presenting a 50-ohm impedance.

The transmitter group provides complete coverage, in five bands, of the frequencies in the 2 to 32 megacycle range. The equipment is capable of providing a nominal average power output of 15 watts when used as a separate transmitter and 1.5 watts output when used as an exciter for larger transmitters.

Operation of the transmitter group is similar to any conventional cw transmitter. An electrical frequency synthesizer generates a continuous radio frequency which is amplified by a radio frequency amplifier. During cw operation the amplifier is controlled by means of a telegraph key. The output of the amplifier is either coupled to an antenna for direct transmission, or coupled to the power amplifier of a larger transmitter, amplified to a higher power level and then applied to the antenna for transmission.

1-3. DESCRIPTION OF UNITS.

a. GENERAL.--The transmitter group is comprised of seven separate units and an electronic equipment modification kit: namely, Electrical Frequency Synthesizer O-1115/URC(GFM), Interconnecting Unit MX-3645/WRA-3, Radio Frequency Amplifier AM-2819/WRA-3, Power Supply PP-2796/WRA-3, Electrical Equipment Cabinet CY-3022/WRA-3, Resilient Mount MT-2661/WRA-3, Relay

Assembly RE-754/WRT-4, and Modification Kit MK-846/WRA-3. Four of the seven units (synthesizer, amplifier, power supply, and interconnecting unit) are drawer mounted in the electrical equipment cabinet unit. Each of the drawer units have two front panel handles used for withdrawing the units, on runner slides, from the cabinet. When completely withdrawn from the cabinet, the synthesizer, radio frequency amplifier, and interconnecting unit can be locked in that position or tilted and locked, up or down, in a 90 degree position. In addition, the radio frequency amplifier and interconnecting unit can be tilted, up or down, in a 45 degree position. The remaining unit, the power supply, can be tilted in a 45 or 90 degree up position only. The resilient mount provides mounting facilities for the electrical equipment cabinet. The relay assembly and modification kit are used only when the transmitter group is used as an exciter for larger transmitting equipment.

Individual characteristics of the various units and modification kit of the transmitter group are as follows.

b. ELECTRICAL EQUIPMENT CABINET CY-3022/WRA-3. -- The electrical equipment cabinet, unit 3, houses four units of the transmitter group. This unit also contains the interunit connecting cables, a forced air cooling system, line fuses, MAIN POWER switch, line filter, an autotransformer, and miscellaneous parts.

c. ELECTRICAL FREQUENCY SYNTHESIZER O-1115/URC(GFM). -- The electrical frequency synthesizer, unit 5, provides rf from 2 to 32 mc in four bands and also provides a 1 mc reference signal. (Refer to paragraph 1-4a(1) for frequencies of operation.) This unit serves as the master oscillator for the radio frequency amplifier, and has a frequency stability of one part in 100 million. The synthesizer has a self-contained power supply. All operating controls, meters and spare fuses are located on the front panel. Refer to NAVSHIPS 94829 for complete information concerning the operation of this unit.

d. INTERCONNECTING UNIT MX-3645/WRA-3. -- The interconnecting unit, unit 4, provides for the termination of various cables within the transmitter group, when the transmitter group is not being used with auxiliary equipment. For auxiliary equipment details, refer to NAVSHIPS 0967-047-7010. This unit has no front panel controls, meters or fuses.

e. RADIO FREQUENCY AMPLIFIER AM-2819/WRA-3. -- The radio frequency amplifier, unit 1,

can be tuned through the frequency range of from 2 to 32 mc in five bands (refer to paragraph 1-4a(2) for information concerning the bands). The power output of the amplifier is normally adjusted to 15 watts for direct transmission. The circuit consists of a balanced modulator, driver, and power amplifier. The balanced modulator function is used only when auxiliary equipment is installed. A 15 watt dummy load, for tuning purposes, is also included in this unit. All controls and a single meter are located on the front panel.

f. POWER SUPPLY PP-2796/WRA-3. -- The power supply, unit 2, provides all the voltages required for operation of the radio frequency amplifier, as well as voltages for the interconnecting unit and control voltage for the transmitter group. Application of power to the various units of the transmitter group is controlled by protective circuits and warning devices. A plate time meter is included as part of the power supply circuit. The meter indicates in hours and tenths of hours the accumulated time that plate voltage has been applied to the power amplifier tube in the radio frequency amplifier. All operating controls, a PA PLATE CURRENT meter, and spare fuses for the power supply and associated cabinet are located on the front panel.

g. RESILIENT MOUNT MT-2661/WRA-3. -- The resilient mount, unit 8, consists of two separate parts: 1) the base mount and 2) the stabilizer mount. The base mount secures the base of the electrical equipment cabinet to the installation position and damps vertical vibrations. The stabilizer mount secures the rear of the electrical equipment cabinet to the bulkhead and damps horizontal vibrations.

h. RELAY ASSEMBLY RE-754/WRT-4. -- The relay assembly, unit 7, is in essence an antenna transfer relay, in that it provides the means for electrically transferring an antenna to a desired equipment during transmission. No external operating controls are provided. Normally the relay assembly is used only when the transmitter group is used with auxiliary equipment and in conjunction with the AN/URC-32 or AN/WRT-2 equipment.

i. MODIFICATION KIT MK-846/WRA-3. -- The modification kit is used only when the transmitter group is used as an exciter for the AN/URC-32 or AN/WRT-2 equipment. In addition to cables, connectors and miscellaneous hardware, the kit also contains Transmitter Transfer Control C-6562/WRA-3, unit 6.

1-4. REFERENCE DATA.

a. FREQUENCY RANGE.

(1) ELECTRICAL FREQUENCY SYNTHESIZER O-1115/URC(GFM).

Band 1: 2 to 4.25 mc - one channel every 12.5 cycles.

Band 2: 4 to 8.5 mc - one channel every 25 cycles.

Band 3: 8 to 17 mc - one channel every 50 cycles.

Band 4: 16 to 34 mc - one channel every 100 cycles.

NOTE

The frequency range from 32 to 34 mc is not used.

(2) RADIO FREQUENCY AMPLIFIER AM-2819/WRA-3.

Band 1: 2 to 4 mc, continuously variable.

Band 2: 4 to 8 mc, continuously variable.

Band 3: 8 to 16 mc, continuously variable.

Band 4: 16 to 23 mc, continuously variable.

Band 5: 23 to 32 mc, continuously variable.

b. TYPE OF FREQUENCY CONTROL.

(1) ELECTRICAL FREQUENCY SYNTHESIZER O-1115/URC(GFM). -- The frequency of the electrical frequency synthesizer is crystal and reactance controlled.

(2) RADIO FREQUENCY AMPLIFIER AM-2819/WRA-3. -- The radio frequency amplifier is manually controlled and reactance tuned. The output frequency is determined by the electrical frequency synthesizer.

c. TYPE OF EMISSION AND MODULATION CHARACTERISTICS. -- Continuous wave, A0, or A1 emission.

d. POWER OUTPUT.

(1) FOR DIRECT TRANSMISSION. -- Adjustable up to 15 watts, into a 50-ohm load.

(2) FOR EXCITATION. -- Adjustable up to 1.5 watts, into a 50-ohm load.

e. FREQUENCY STABILITY. -- The frequency of the transmitter group is stable to one part in 100 million per day.

f. ELECTRICAL INPUT AND OUTPUT DATA.

(1) ELECTRICAL FREQUENCY SYNTHESIZER O-1115/URC(GFM). -- The output of the electrical frequency synthesizer is adjustable from 1.0 to 2.5 volts. This output is 2.0 volts when the O-1115/URC is used with the transmitter group.

(2) RADIO FREQUENCY AMPLIFIER AM-2819/WRA-3. -- Input from the electrical frequency

synthesizer is 80 milliwatts into 50-ohm load. An additional input is applied to the radio frequency amplifier only when auxiliary equipment is used. This input also has a nominal input impedance of 50 ohms. The output is variable to either 1.5 watts into 50 ohms (for excitation) or 15 watts into 50 ohms (for direct transmission).

g. CHARACTERISTICS OF RECOMMENDED ANTENNAS. -- For direct transmission, a tunable antenna with an input impedance of 50 ohms is required.

h. AMBIENT TEMPERATURE LIMITATIONS. -- The transmitter group will operate satisfactorily within the ambient temperature range of from 0 to 50° C (32 to 122° F).

i. CHARACTERISTICS OF POWER SUPPLY PP-2796/WRA-3. -- The power supply operates with 115 volt, 47.5 to 63.0 cps, single phase primary power input. The power consumption is a nominal 595 watts during standby operation and a nominal 1020 watts during locked-key cw operation. The power factor is from 0.85 to 1.0, depending upon mode of operation. The power supply has the following nominal outputs:

2 amp at +28 vdc
0.7 amp at -28 vdc
1.4 amp at -28 vdc
-24 to -39 vdc (bias)
80 ma at +300 vdc
220 ma at +950 vdc
1.4 amp at 144 (rms),
400 cps quasi square wave

1-5. EQUIPMENT SUPPLIED.

Transmitter Group AN/WRA-3 consists of the major units and miscellaneous items listed in table 1-1.

1-6. EQUIPMENT AND PUBLICATIONS REQUIRED BUT NOT SUPPLIED.

A list of all the equipment and publications required but not supplied comprises table 1-2.

1-7. FACTORY OR FIELD CHANGES.

No factory or field changes have been made as of the date of this original publication.

1-8. EQUIPMENT SIMILARITIES.

Transmitter Group AN/WRA-3 is similar to Transmitter Group AN/WRA-3(XN-1). The basic differences between the two equipments is that the AN/WRA-3 has been upgraded in the use of non-standard parts, an rf drive control gear box has been added, and rf dial lights have been incorporated. Also, Relay Assembly RE-754/WRT-4 is now supplied and the accompanying modification kit has been changed, Transmitter Transfer Control C-6562/WRA-3 (part of the modification kit) has been redesigned, and Synthesizer O-1115/URC is now used in place of the O-792/SRC.

1-9. PREPARATION FOR RESHIPMENT.

Since there are no special precautions to be observed in preparing the transmitter group for reshipment, preparation for reshipment can be accomplished by following standard naval packaging procedures for electronic equipment.

TABLE 1-1. EQUIPMENT SUPPLIED

QTY PER EQUIP	NOMENCLATURE		UNIT NO.	OVER-ALL DIMENSIONS (IN.)			VOLUME (CU FT)	WEIGHT (LB)
	NAME	DESIGNATION		HEIGHT	WIDTH	DEPTH		
1	Transmitter Group	AN/WRA-3					12.1	607
1	Electrical Equipment Cabinet	CY-3022/WRA-3	3	37.5	22.25	23.25	11.1	265.5
1	Electrical Fre- quency Synthe- sizer (GFM)***	O-1115/URC	5	5.25	19	21.5	1.23	90
1	Radio Frequency Amplifier	AM-2819/WRA-3	1	7	19	21.5	1.65	45
1	Power Supply	PP-2796/WRA-3	2	7	19	23.25	1.78	103
1	Interconnecting Unit	MX-3645/WRA-3	4	7	19	21.8	1.6	9.5
1	Resilient Mount Base Stabilizer	MT-2661/WRA-3	8	4 6.75	22.2 25.75	22.7 2.75	1.14 0.27	67 27
1	Relay Assembly	RE-754/WRT-4	7	3.75	5.5	5.63	0.08	3
1	Modification Kit	MK-846/WRA-3	-	-	-	-	-	-
2	Technical Man- ual for Trans- mitter Group AN/WRA-3	NAVSHIPS 0967-031-9010	-	-	-	-	-	-
2	Maintenance Standards Book for Transmitter Group AN/WRA-3	NAVSHIPS 0967-031-9030	-	-	-	-	-	-
1	Performance Standard Sheet for Transmitter Group AN/WRA-3	NAVSHIPS 0967-031-9020	-	-	-	-	-	-
2	Technical Man- ual for Electrical Frequency Syn- thesizer O-1115/ URC (GFM)	NAVSHIPS 94829	-	-	-	-	-	-
	Miscellaneous Parts Box, containing:	-		2.0	6.0	9.0	-	-
1	Connector	MS35168-88F	-	-	-	-	-	-
1	Connector	UG-21E/U	-	-	-	-	-	-
2	Connector	UG-154A/U	-	-	-	-	-	-
4	Fuse, 6 ampere*	F02A250V6AS (3F1, 3F2)	-	-	-	-	-	-
4	Fuse, 12 ampere* Miscellaneous Hardware**	F03A250V12AS (3F1, 3F2)	-	-	-	-	-	-

*Alternate fuses for 115 vac or 230 vac operation.

**For fastening the resilient mount to the electrical equipment cabinet.

***Not necessarily shipped from AN/WRA-3 contractor.

TABLE 1-2. EQUIPMENT AND PUBLICATIONS REQUIRED BUT NOT SUPPLIED

QTY PER EQUIP	NOMENCLATURE		REQUIRED USE	REQUIRED CHARACTERISTICS
	NAME	DESIGNATION		
1	Electronic Multimeter	AN/USM-116	For trouble shooting and maintenance	Voltage: 0-50 vac (rf) Frequency: 60 cycles to 32 mc
1	Multimeter	AN/PSM-4	For trouble shooting and maintenance	Voltages: 6 to 800 vac (60/400 cycle) 1 to 1050 vdc Resistance: 0 to 10 mego
1	Oscilloscope	AN/USM-117	For trouble shooting and maintenance	Vertical sensitivity: 50 volts per CM Horizontal Period: 2.5 milliseconds
1	RF Signal Generator	CAQI-606-A	For trouble shooting and maintenance	Frequency: .5 to 3.5 mc Output: .8 volt (rms)
1	Dummy Load	DA-91/U	For trouble shooting and maintenance	50 ohm termination
1	Radio Receiver	R-1051/URC	For trouble shooting and maintenance	Capable of 32 mc reception; must have a signal strength meter.
1	Tube Socket Adapter Test Kit	AN/USM-119	For trouble shooting and maintenance	
*	Bulk Cable	RG218/U	For Relay Assembly RE-754/WRT-4	
*	Bulk Cable	DSGA-4	Power Cable	
*	Bulk Cable	RG58C/U	RF Interconnecting Cable	
*	Bulk Cable	TTHFWA-1 1/2	For connecting Re- lay Assy RE-754/ WRT-4 and hand key (if used)	
*	Bulk Cable	MSCA-7	For connecting Transmitter Trans- fer Control C-6562/WRA-3	
*	Bulk Cable	RG213/U	For Relay As- sembly RE-754/ WRT-4	
1	Telegraph Key	Any type	For manual keying of AN/WRA-3	
	Miscellaneous Hardware	--	--	

* As required by specific AN/WRT-2 or AN/URC-32 installation when used with Modification
Kit MK-846/WRA-3.

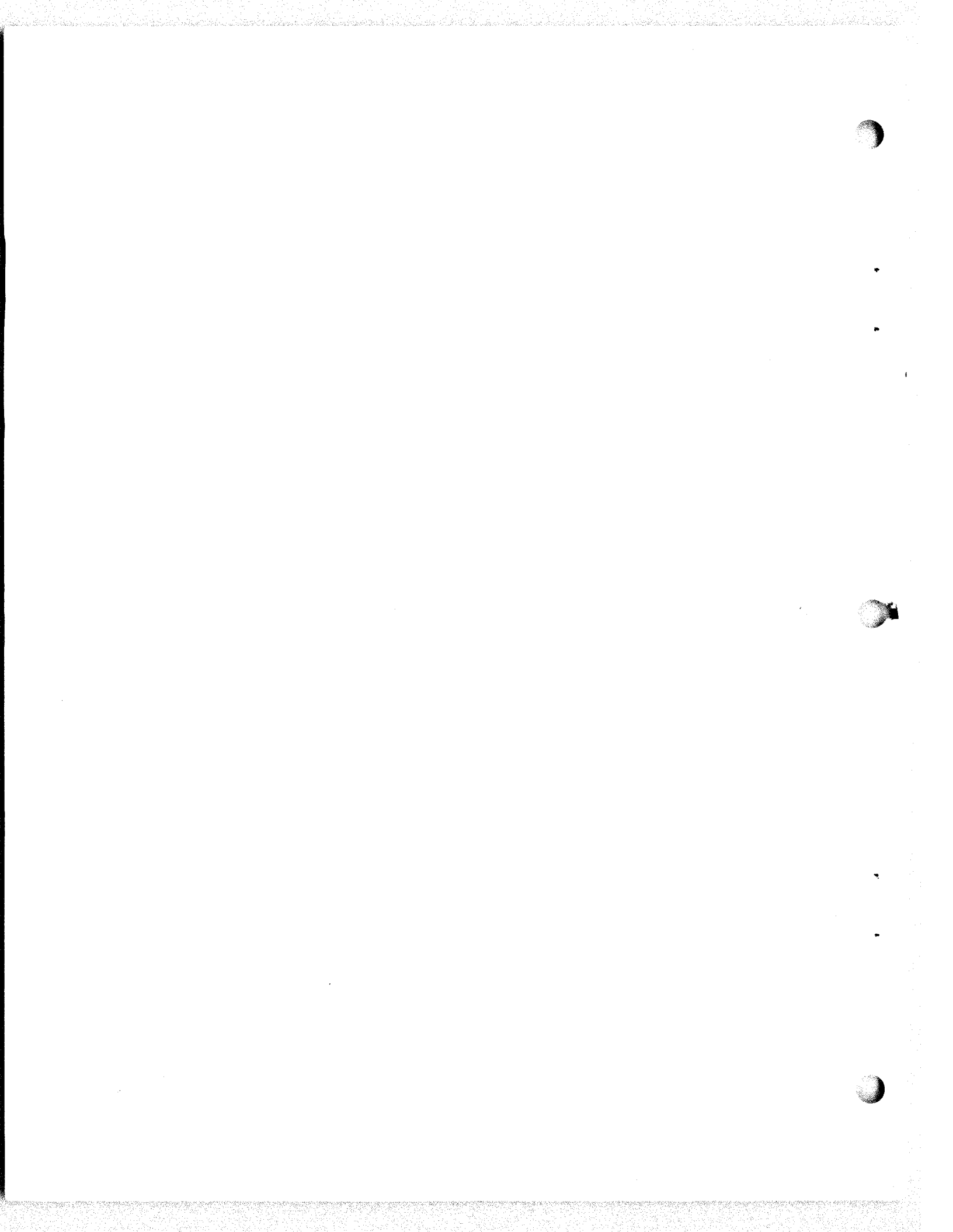

SECTION 2

INSTALLATION

2-1. UNPACKING AND HANDLING.

As shipped, Transmitter Group AN/WRA-3 is contained in three separate packing crates: one crate contains the transmitter proper, with Relay Assembly RE-754/WRT-4 enclosed; a second crate contains Resilient Mount MT-2661/WRA-3 and miscellaneous hardware; and a third crate contains Modification Kit MK-846/WRA-3. Note that the modification kit and relay assembly are used only when the transmitter group is used as an exciter for Radio Set AN/URC-32 or Radio Transmitting Set AN/WRT-2.

Hoist used in moving the equipment should be equipped with a sling. No special tools are required for opening the packing crates.

CAUTION

Do not leave the unpacked transmitter in an upright position, without support, when it is not secured to one or both of its shock mounts.

2-2. POWER REQUIREMENTS AND DISTRIBUTION.

The Transmitter Group requires 115 v or 230 v, single phase, 47.5 to 63.0 cps ac, and draws 850 va at standby, and 1430 va when operating with locked key. The power factor under these conditions is from 0.85 to 1.00. See figure 5-13 for the primary power distribution diagram. If an electrical frequency synthesizer operating on 115 volt 400 cps power input must be used, in an emergency, refer to paragraph 2-8 for special installation instructions. Refer to paragraph 2-9 for instructions on returning the equipment to its normal configuration after emergency synthesizer use.

2-3. INSTALLATION LAYOUT.

When used as an independent transmitter, the installation layout for the transmitter group is left to the discretion of the installation officer. He will consider operating convenience, maintenance accessibility, availability of power and antenna connections, and ventilation.

When used as an exciter, the transmitter group must be positioned close to the transmitter being excited (Radio Set AN/URC-32 or Radio Transmitting Set AN/WRT-2). This will enable the operator to adjust the transmitter group while observing the front panel meters of the larger transmitter. It should also be possible for the operator to reach the RF DRIVE control on the transmitter group while tuning the larger transmitters.

For proper ventilation, a minimum of four inches must separate the sides of the equipment or bulkheads. Enough space must be allotted in front of the equipment to allow drawer withdrawal. The stabilizer installed between the rear of the equipment cabinet and the bulkhead provides sufficient clearance between the cabinet and bulkhead for normal ventilation.

2-4. INSTALLATION REQUIREMENTS.

a. General. -- The transmitter group must be dismantled when transported through a 25-inch hatch. The dismantling and reassembly procedures are used when sufficient clearance is not available for the assembled transmitter group. See figure 2-1 for dimensions of the transmitter group. Omit the dismantling and reassembly procedures when sufficient clearances are available, and use instructions and procedures beginning with paragraph 2-4c.

b. DISMANTLING. -- During dismantling of the transmitter group, the units are removed from the electrical equipment cabinet, and the cabinet is disassembled. No special tools are required for dismantling, but a set of standard socket wrenches and Allen wrenches are required. At least two men are required to dismantle the transmitter group, and one of the two men must be an electronics technician. Four or five hours (eight or ten man-hours) are normally required for two men to dismantle the transmitter group. Time required for reassembly is normally twice as much as the time required for dismantling. Paragraphs 2-4b(1) through 2-4b(5) include instructions for removal of the units from, and disassembly of, the electrical equipment cabinet.

(1) REMOVAL OF POWER SUPPLY PP-2796/WRA-3. (See figure 2-2.)

- Step 1. Loosen four captive screws on front panel, and pull drawer out on slides.
- Step 2. Pull tilt-lock release handle at each side of drawer (figure 2-3), and tilt drawer up 90°; allow tilt locks to engage; lock drawer in 90° position.
- Step 3. Remove screws holding bottom cover and remove cover to gain access to terminal boards (figure 2-4).
- Step 4. At applicable terminal boards, disconnect wires of interconnecting cable from electrical equipment cabinet. Be sure that each wire is legibly tagged to

Figure 2-1

NAVSHIPS 0967-031-9010

AN/WRA-3
INSTALLATION

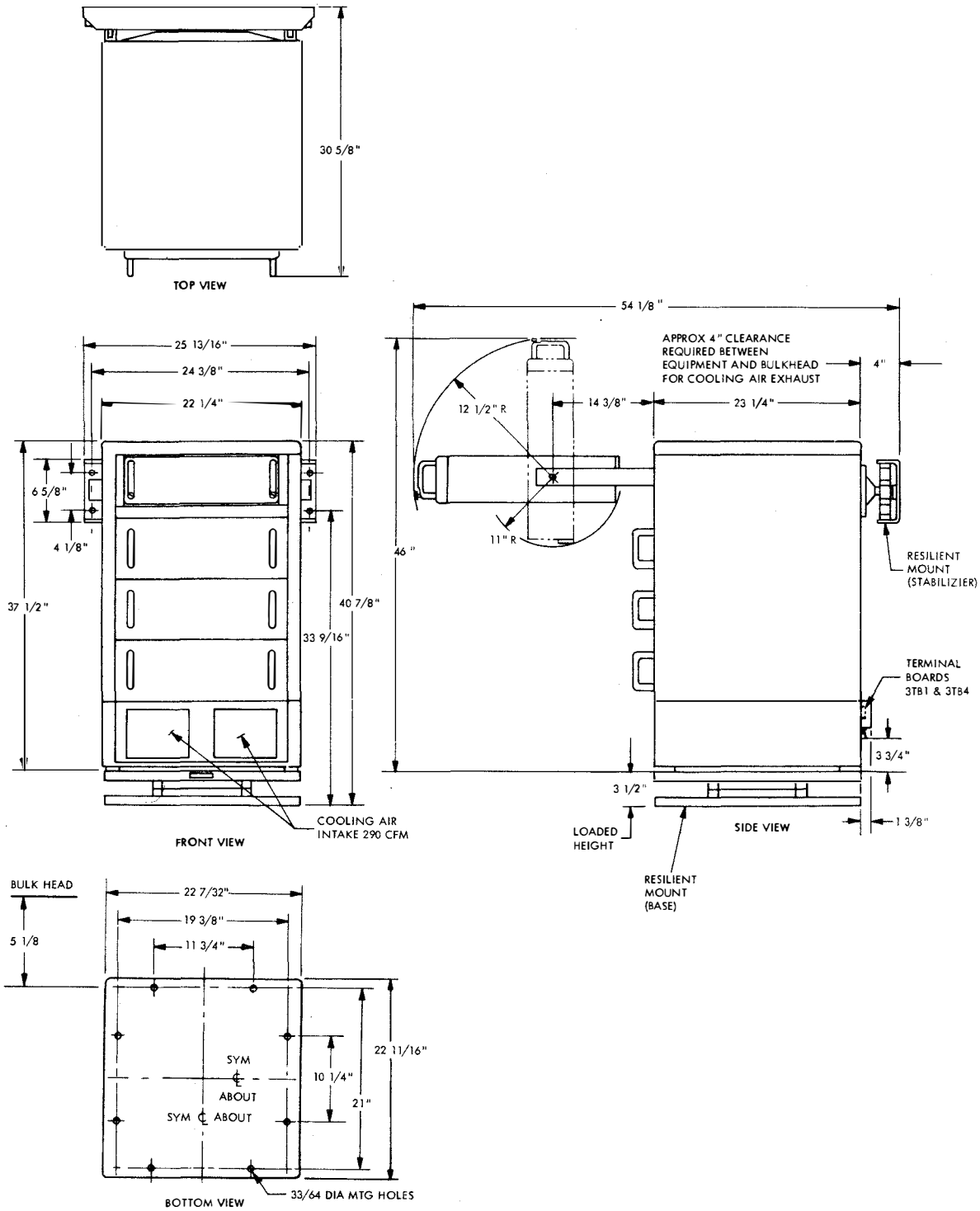

657-2

Figure 2-1. Transmitter Group AN/WRA-3, Dimensional Outline Drawing (Sheet 1 of 2)

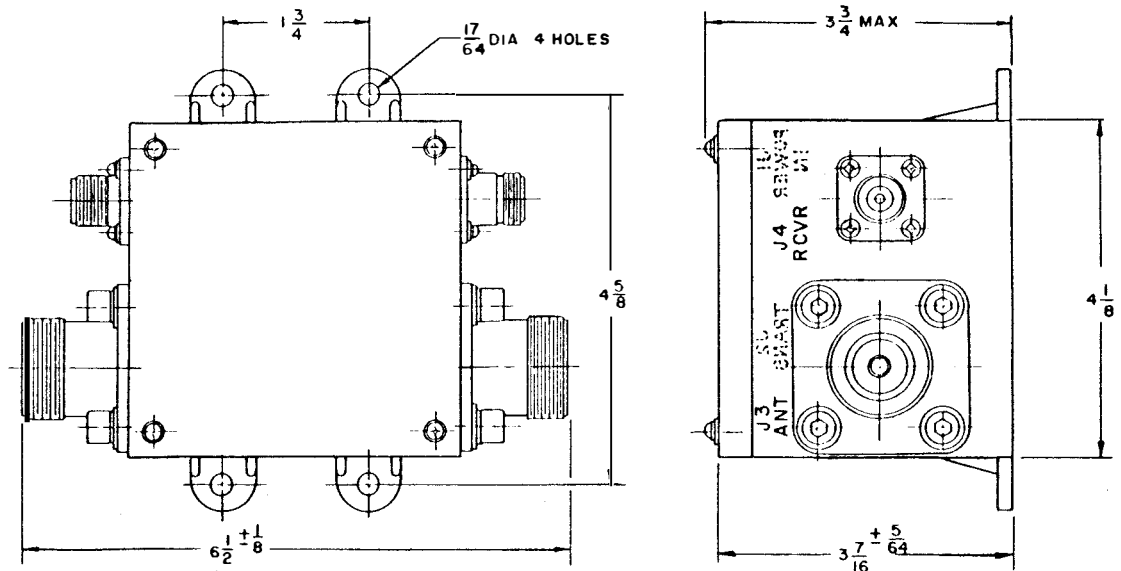

657-3

Figure 2-1. Transmitter Group AN/WRA-3, Dimensional Outline Drawing (Sheet 2 of 2)

indicate proper terminal and terminal board. Disconnect 3P20 from 2J1. Remove cable clamps from interconnecting cable and pull cable free from power supply.

- Step 5. Pull tilt-lock release handles and tilt drawer back to original position.
- Step 6. Loosen two tilt block screws (one in each drawer slide) and remove tilt block (figure 2-3).
- Step 7. Two men are required to remove unit. Pull tilt-lock release handles, lift drawer vertically until disengaged from slides, and remove.

CAUTION

Equipment may be damaged if one man removes unit without assistance.

(2) REMOVAL OF RADIO FREQUENCY AMPLIFIER AM-2819/WRA-3. (See figure 2-2.)

- Step 1. Perform steps 1 and 2 of paragraph 2-4b(1).

- Step 2. Remove covers from bottom of unit (figure 2-5).
- Step 3. Disconnect wires of interconnecting cable from electrical equipment cabinet at applicable terminal boards. Be sure to legibly tag each wire to indicate proper terminal. Disconnect four coaxial connectors (3P12, 3P21, 3P8, and 3P15) from radio frequency amplifier.
- Step 4. Repeat steps 5 through 7 of paragraph 2-4b(1).

(3) REMOVAL OF INTERCONNECTING UNIT MX-3645/WRA-3. (See figure 2-2.)

- Step 1. Perform steps 1 and 2 of paragraph 2-4b(1).
- Step 2. Disconnect wires of interconnecting cable at terminal boards 4TB1 and 4TB2, (figure 2-6). Be sure that each wire is legibly tagged to indicate proper terminal. Disconnect 3P5 from 4J2 and 3P19 from 4J1.
- Step 3. Perform steps 5 through 7 of paragraph 2-4b(1).

(4) REMOVAL OF ELECTRICAL FREQUENCY SYNTHESIZER O-1115/URC. (See figure 2-2.)

- Step 1. Disconnect cables from connectors (figure 2-7) at rear of electrical frequency synthesizer slide frame.
- Step 2. Loosen two captive screws in front panel handles and pull unit out on slides. This will allow access to four screws which hold rear of slide frame to cabinet brackets.
- Step 3. Remove four socket-head cap screws which hold top panel of the cabinet, (figure 2-2). Remove top panel.
- Step 4. Two men are required to perform this step. Supporting rear of unit's slide frame, remove four screws holding it to brackets at rear of cabinet.

CAUTION

Equipment may be damaged if one man removes unit without assistance.

- Step 5. Slide unit back into frame and fasten captive screws. Support unit, and remove eight screws which hold front of synthesizer. Remove unit, complete with slide frame.

(5) DISASSEMBLY OF ELECTRICAL EQUIPMENT CABINET CY-3022/WRA-3. (See figure 2-2.)

- Step 1. Remove 10 screws holding rear base cover to cabinet and remove cover.
- Step 2. Disconnect 3P2 from 3J1 (figure 2-8), inside connector compartment.
- Step 3. Disconnect wires of cable running from cabinet rear panel assembly to base terminal boards 3TB3 and 3TB4 (figure 2-9). Loosen cable clamps holding cable to base section of cabinet.
- Step 4. Remove 16 screws holding back panel to cabinet (figure 2-2). Remove rear panel assembly. Be careful when withdrawing cables from cabinet.
- Step 5. Remove 20 screws holding each of two inter-drawer shields and remove shields.
- Step 6. Remove four screws holding front panels of cabinet. Remove panels.
- Step 7. Remove eight screws holding each of two base side panels. Remove base side panels.

- Step 8. Hold one side assembly to prevent falling, and remove lower corner post screws from base. Repeat this step for other side assembly.

c. REASSEMBLY AND CONNECTIONS. -- The transmitter group is reassembled in reverse order of disassembly. See figure 2-10 for interunit cable connections.

If the transmitter group is to be used as an exciter for larger transmitters, refer to figure 2-10 for data pertaining to the connections for Relay Assembly RE-754/WRT-4 and the keying relay. Also refer to this figure if a hand key is to be used. If required, these connections are to be made prior to permanent mounting of the equipment. Refer to table 1-2 for applicable cable information.

CAUTION

If primary power source is 115 vac, verify that 3T1 is connected for same, e.g., gray wire no. 9 (figures 2-9 and 2-10) is connected to 3T1-2. If primary power source is 230 vac, gray wire no. 9 is to be connected to 3T1-1. Also verify line fuses; 12 amps for 115 vac, 6 amps for 230 vac. Refer to table 1-2 for power cable data.

To ensure that the base mount (figure 2-1) is installed correctly, bolt it to the deck with the manufacturer's inscription in normal reading position toward the front of the cabinet. If space permits, bolt the electrical equipment cabinet base to the base mount before reassembly of the transmitter group. The mount bolts are installed at the bottom corners of the base (figures 2-1 and 2-2).

To ensure that the stabilizer mount (figure 2-1) is installed correctly, bolt the movable cabinet mounting bracket to the upper rear portion of the electrical equipment cabinet with the four 3/8-inch bolts. Bolt the stabilizer channel bracket to the bulkhead with four 3/8-inch bolts.

d. OUTLINE DRAWING. -- Figure 2-1 is an outline drawing providing all of the dimensions affecting installation of the transmitter group, including mounting dimensions and clearances.

e. INTERCONNECTION. -- Figure 2-10 is an interconnecting diagram of the transmitter group proper.

(1) RADIO SET AN/URC-32. -- Complete instructions for interconnecting the AN/URC-32 to the AN/WRA-3 are contained in Modification Kit MK-846/WRA-3.

(2) RADIO TRANSMITTING SET AN/WRT-2. -- Complete instructions for interconnecting the AN/WRT-2 to the AN/WRA-3 are contained in

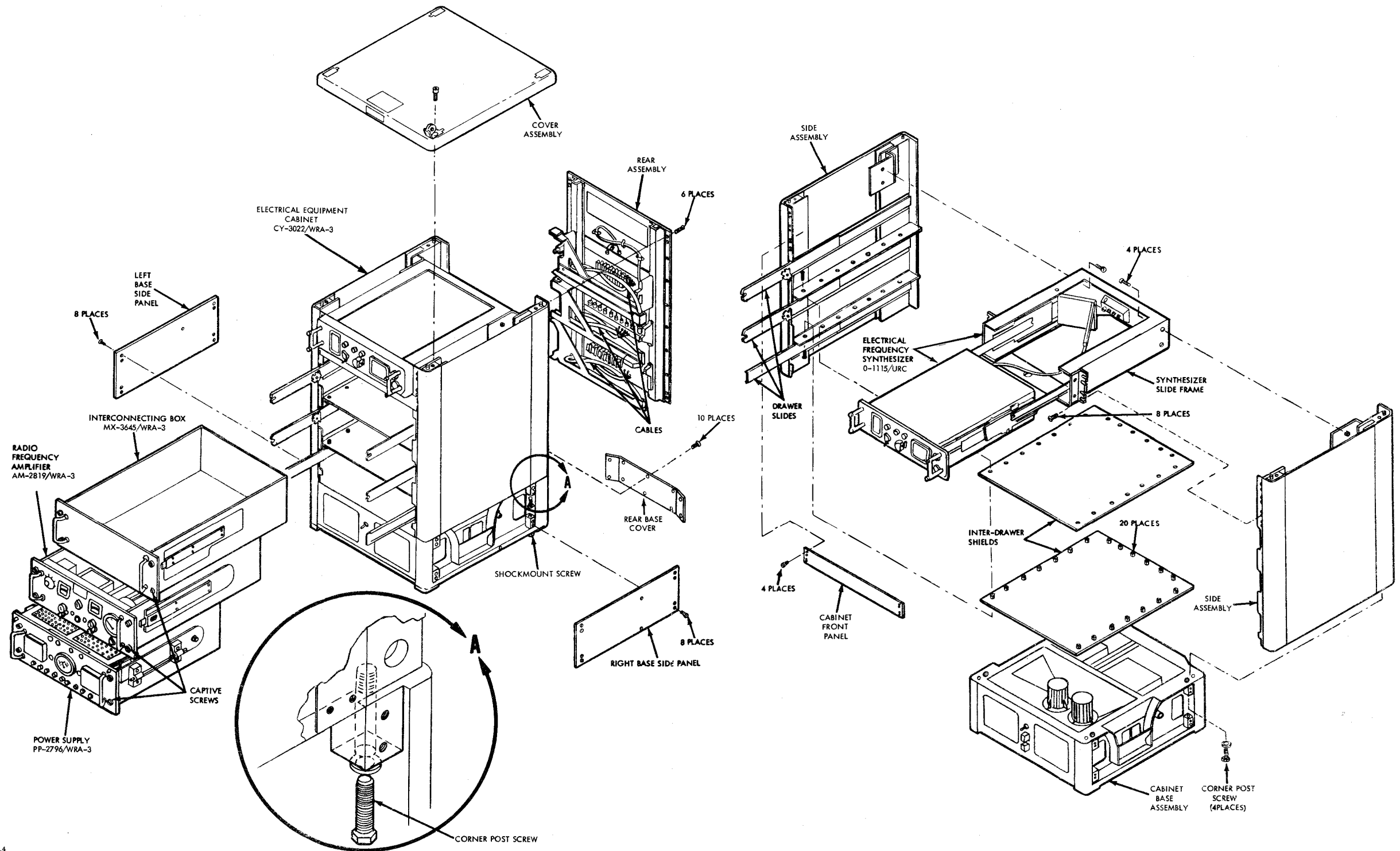

657-4

Figure 2-2. Transmitter Group AN/WRA-3,
Dismantling Diagram

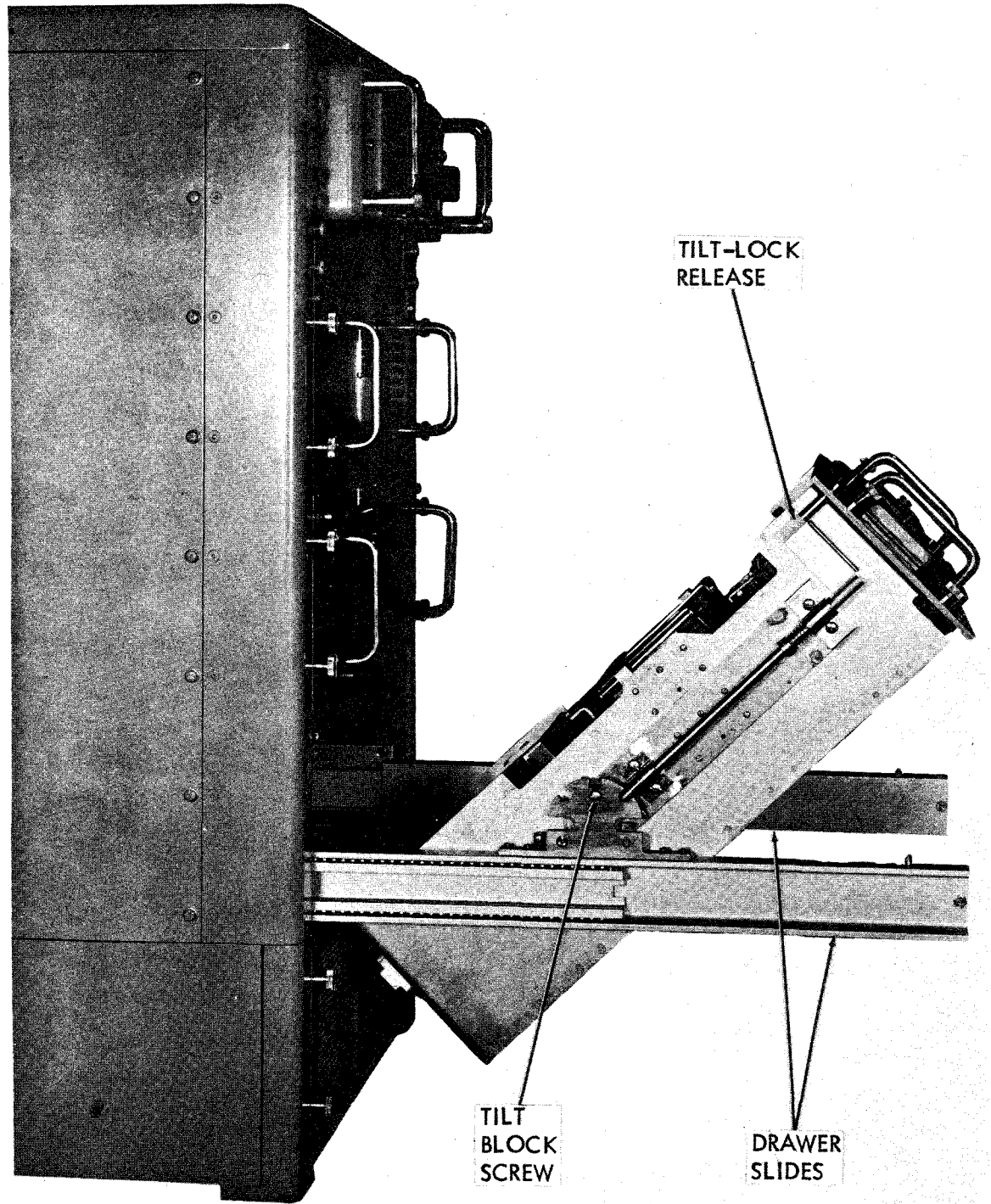

657-5

Figure 2-3. Power Supply PP-2796/WRA-3, Unit 2, Drawer Slide Installation

Modification Kit MK-846/WRA-3.

2-6. INSPECTION AND ADJUSTMENT.

2-5. CABLE ASSEMBLIES.

Cables are not supplied with the transmitter group proper; however, some are supplied as part of Modification Kit MK-846/WRA-3. Complete instructions for the assembly of these cables are contained within the kit. In all cases the fabrication of multiconductor and coaxial cables to connectors should follow the procedures outlined in Electronic Installation Practice Manual NAVSHIPS 900171, Chapters 5 and 10. Also reference should be made to the Armed Services Index of RF Transmission Lines and Fitting, NAVSHIPS 900-102B.

a. GENERAL INSPECTION. -- Before inspecting the transmitter group, make sure that the ship's power is not applied and the MAIN POWER switch on the front panel of the electrical equipment cabinet base is in the OFF position. Then make a visual inspection of all units as follows.

Step 1. Inspect all incoming and outgoing cables for correct installation.

Step 2. Check inside each unit drawer for presence of handtools, loose solder, wire clippings, hardware, or other foreign

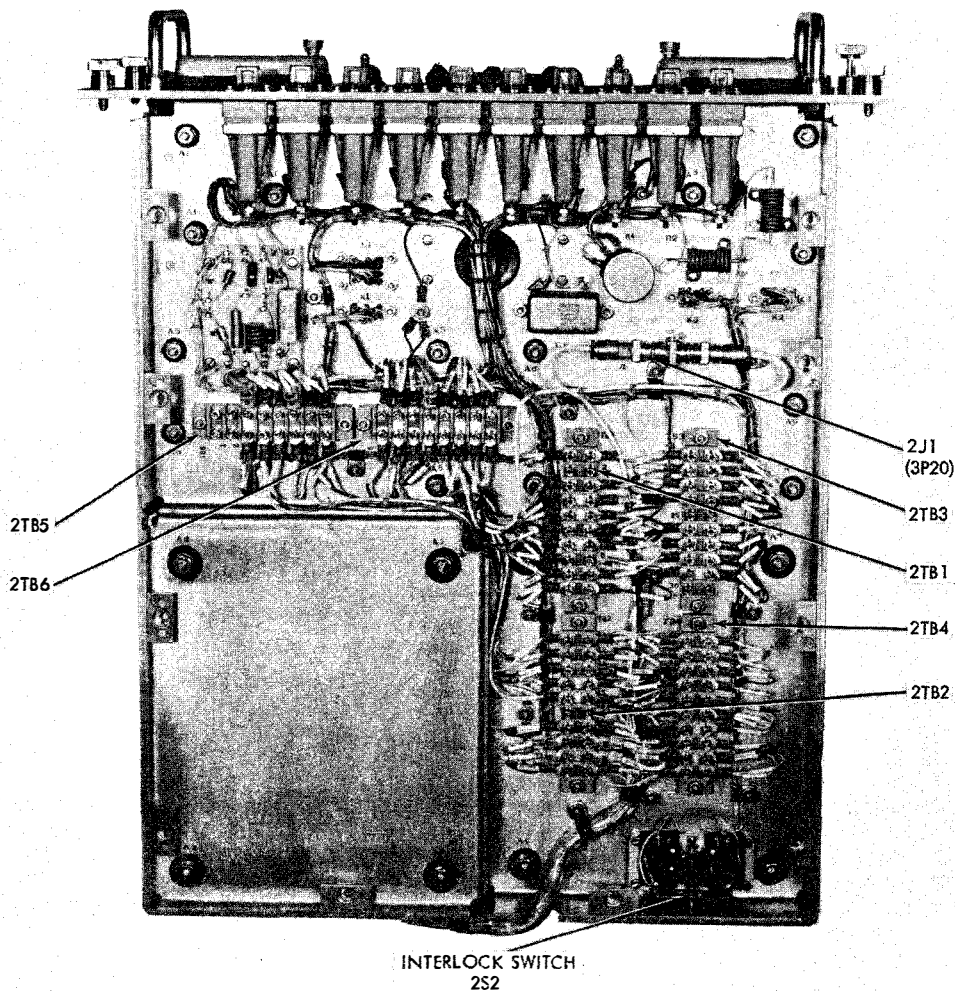

657-6

Figure 2-4. Power Supply PP-2796/WRA-3, Unit 2, Bottom View

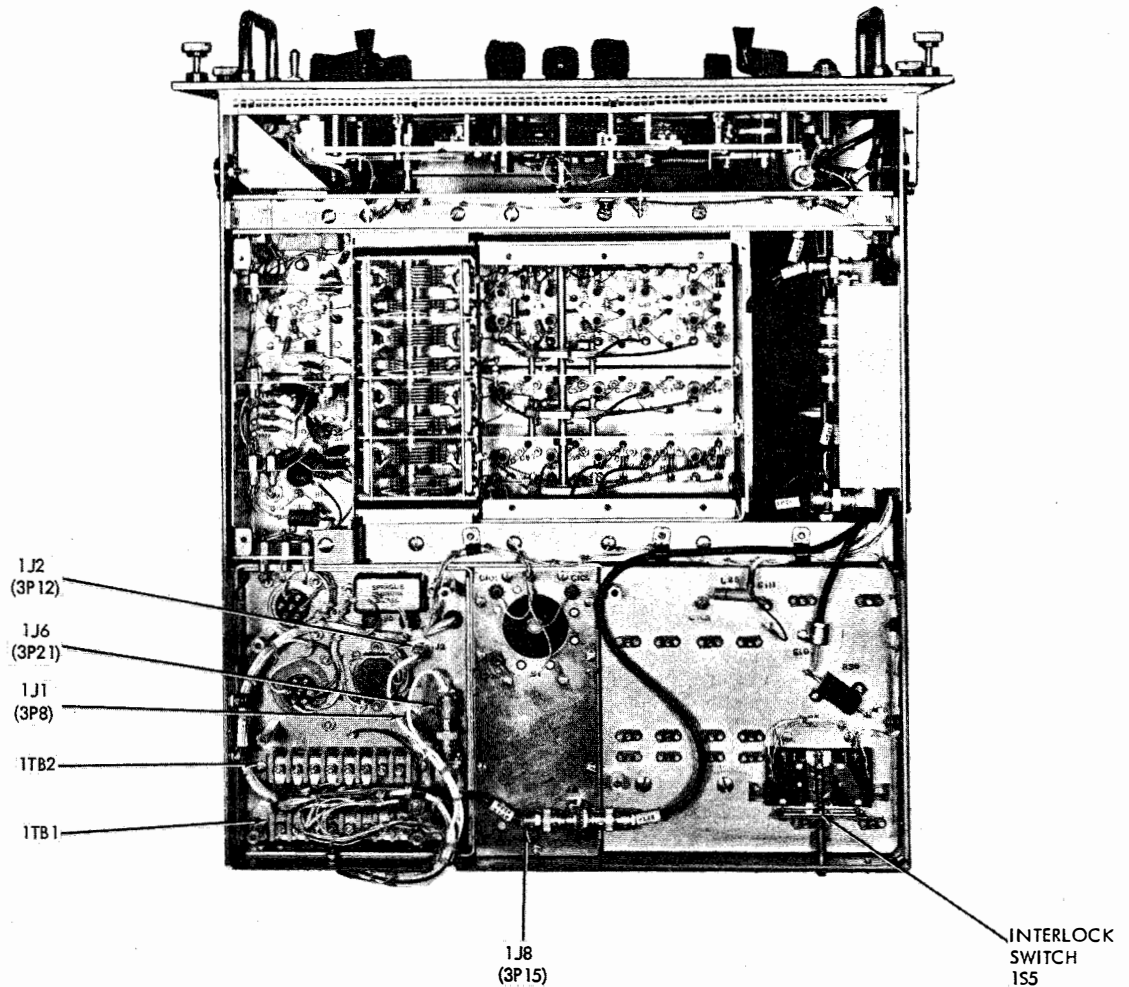

657-7

Figure 2-5. Radio Frequency Amplifier AM-2819/WRA-3, Unit 1, Bottom View

- material.
- Step 3. Check radio frequency amplifier tubes for signs of damage, and make sure they are seated securely.
- Step 4. Open each drawer to full length of travel. Pull tilt-lock releases (figure 2-3) and tilt each drawer to maintenance positions. (The power supply drawer tilts upward only.) There must be no binding in either tilt motion or side motion. If there is, look for damaged parts or foreign material introduced during dismantling and reassembly.
- Step 5. Examine front panels for damaged con-
- trols. Make sure glass indicator covers are intact.
- Step 6. Close all four drawers and secure.
- b. ENERGIZING THE EQUIPMENT FOR THE FIRST TIME.
- Step 1. Check line fuses on front panel of electrical equipment cabinet base. For 115v operation, install 12-amp fuses; for 230v operation, install 6-amp fuses. If placard in panel cutout above fuses gives wrong fuse rating for installation, remove front panel of cabinet base and rotate placard thumbwheel until correct fuse rating appears through cutout in

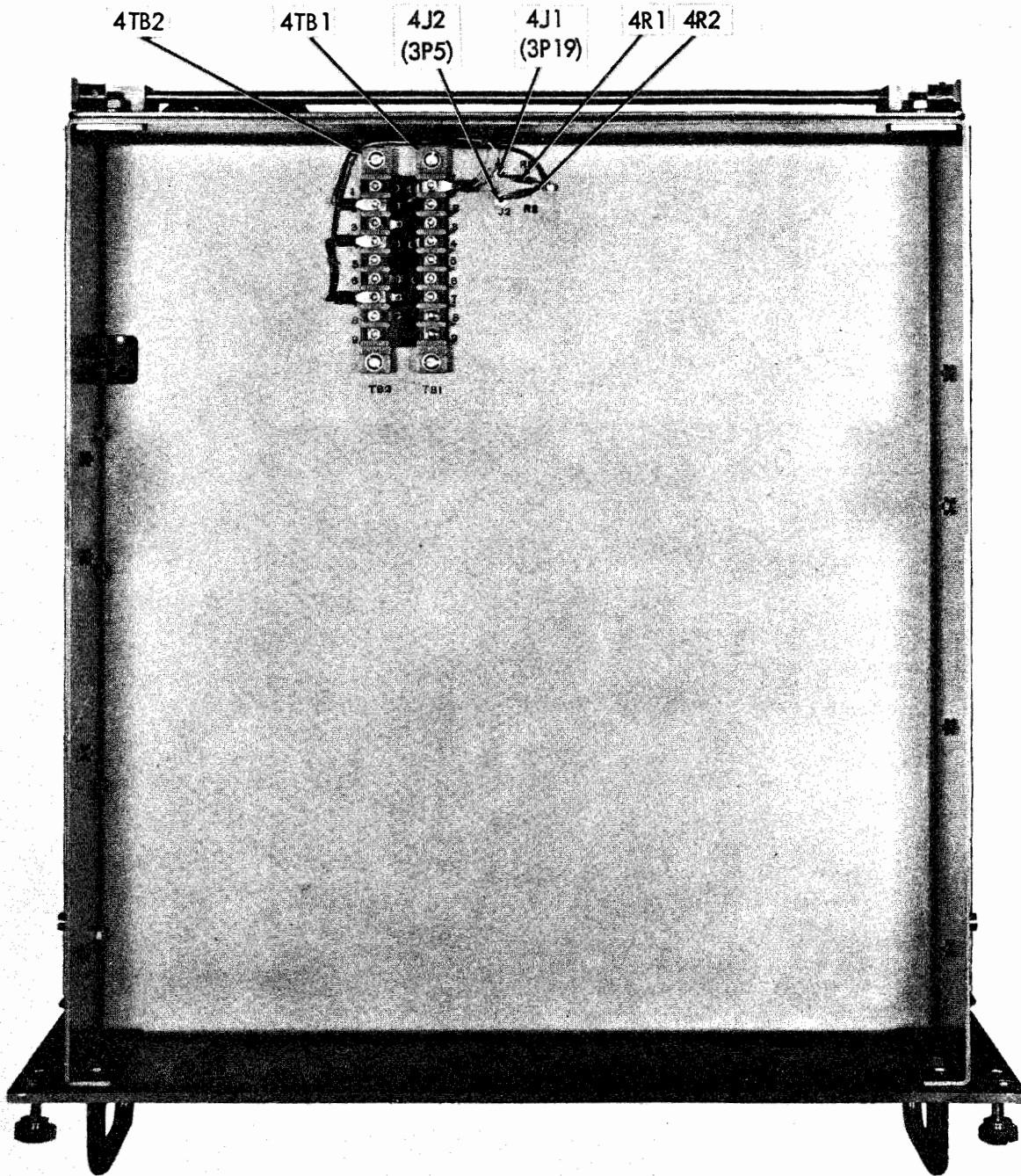

657-8

Figure 2-6. Interconnecting Unit MX-3645/WRA-3, Unit 4, Top View

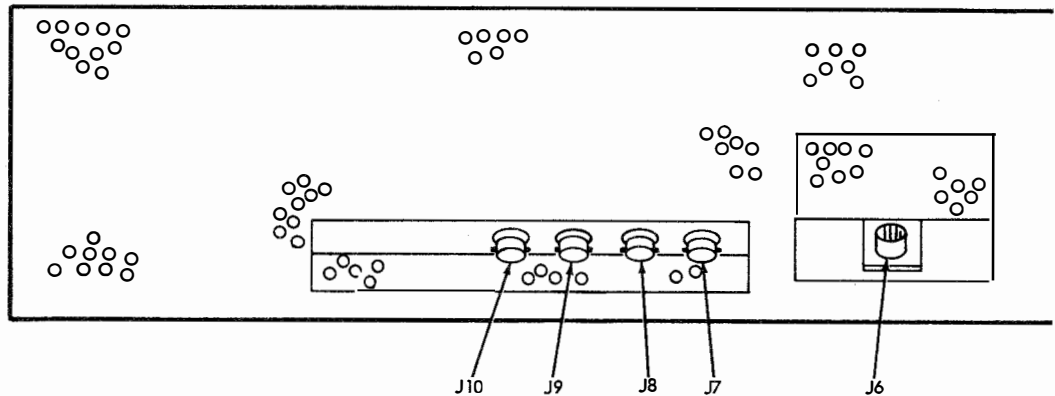

657-9

Figure 2-7. Electrical Frequency Synthesizer O-1115/URC, Unit 5, Rear View

front panel. Replace front panel.

CAUTION

Equipment may be damaged if wrong fuses are used.

- Step 2. Check behind SPARE FUSES doors on power supply front panel. Spare fuses should include duplicates of line fuses which are installed.
 - Step 3. Energize primary power source and perform procedures outlined in paragraph 3-2b(1)(c), steps 1 through 12, setting tuning controls for frequency of 12 mc.
 - Step 4. At completion of step 3, proceed to paragraph 2-6c.
- c. INSTALLATION ADJUSTMENTS. -- Perform the following adjustments before proceeding with paragraph 2-6d.
- Step 1. On radio frequency amplifier, press TEST KEY (figure 3-2) down for an instant and read power supply PA PLATE CURRENT meter (figure 3-3). If reading is more than 200 ma, release TEST KEY immediately. If power supply PLATE OVERLOAD or SCREEN OVERLOAD lamp lights, press corresponding RESET button. If PA PLATE CURRENT meter reads less than 200 ma, omit steps 2 and 3.
 - Step 2. If PA PLATE CURRENT meter indicates more than 200 ma, or OVERLOAD

lamp(s) light, use screwdriver to set power supply BIAS ADJUST to extreme counterclockwise position.

- Step 3. Again press TEST KEY for an instant. If PA PLATE CURRENT meter still reads more than 200 ma, secure transmitter group (paragraph 3-2b(4)(a) and check bias wiring (figure 2-10).
- Step 4. When TEST KEY can be pressed without PA PLATE CURRENT meter indicating more than 200 ma, place TEST KEY in locking position (up).
- Step 5. Set BIAS ADJUST screwdriver adjustment to produce an indication of 190 ma on PA PLATE CURRENT meter.
- Step 6. Press HIGH VOLTAGE OFF switch.
- Step 7. Adjust synthesizer per paragraph 3-2b(2)(a). Synthesizer must be turned on at least one hour before making these adjustments.

d. CHECKING PERFORMANCE.

- Step 1. Perform procedures of paragraph 3-2b(1)(b), steps 1 through 3, and place radio frequency amplifier TUNE OPERATE switch (figure 3-2) in TUNE position.
- Step 2. Press power supply HIGH VOLTAGE ON switch (figure 3-3), and on radio frequency amplifier, set RF DRIVE control for full scale reading on RF OUTPUT meter.

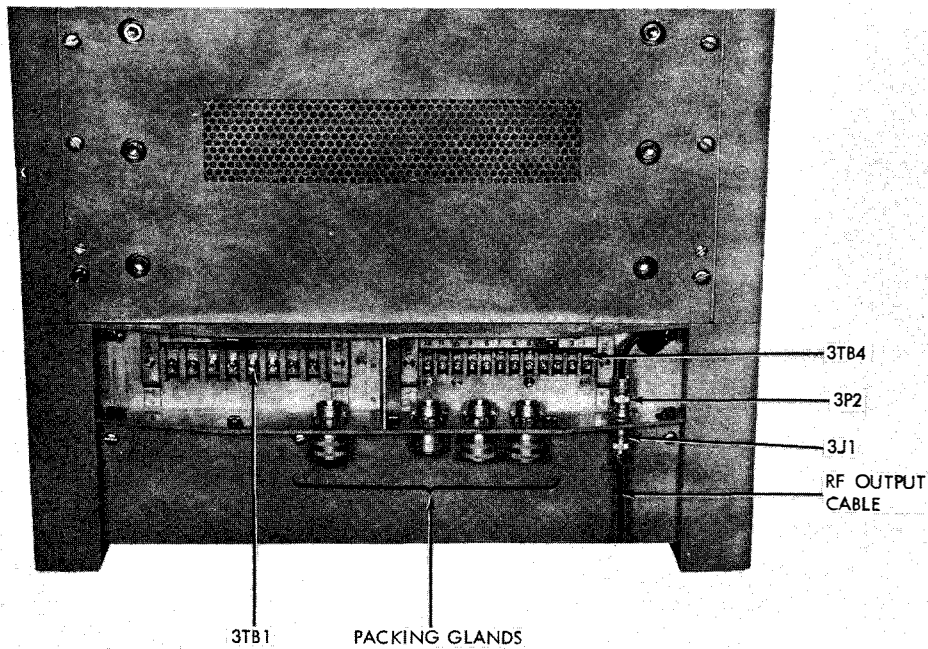

657-10

Figure 2-8. Electrical Equipment Cabinet CY-3022/WRA-3, Unit 3,
External Cable Connector Compartment

- Step 3. Open radio frequency amplifier drawer. Power supply HIGH VOLTAGE ON lamp should extinguish, and radio frequency amplifier RF OUTPUT and power supply PA PLATE CURRENT meters should indicate zero.
- Step 4. Defeat radio frequency amplifier drawer interlock switch 1S5 (figure 2-5) by lifting up plunger and pulling toward rear of equipment. Power supply READY lamp and radio frequency amplifier INTERLOCK DISABLED lamp should both light.
- Step 5. Press power supply HIGH VOLTAGE ON switch. RF OUTPUT meter should read full scale.
- Step 6. Close radio frequency amplifier drawer. READY lamp should illuminate. HIGH VOLTAGE ON and INTERLOCK DISABLED lamps should extinguish. RF OUTPUT and PA PLATE CURRENT meters should indicate zero.
- Step 7. Press HIGH VOLTAGE ON switch. RF OUTPUT meter should read full scale.
- Step 8. Open power supply drawer. RF OUTPUT and PA PLATE CURRENT meters should read zero. HIGH VOLTAGE ON lamp should extinguish.
- Step 9. Disable interlock switch 2S2 (figure 2-4) on power supply drawer by lifting up plunger and pulling toward rear of equipment. READY and INTERLOCK DISABLED lamps on power supply should illuminate.
- Step 10. Press HIGH VOLTAGE ON switch. RF OUTPUT meter should read full scale.
- Step 11. Close power supply drawer. READY lamp should light. HIGH VOLTAGE ON and INTERLOCK DISABLED lamp should go out. RF OUTPUT and PA PLATE CURRENT meter should read zero.
- Step 12. Press HIGH VOLTAGE ON switch. RF OUTPUT meter should read full scale.
- Step 13. Press and release TEST KEY. RF OUTPUT and PA PLATE CURRENT meters should read zero.
- Step 14. Close external telegraph key. If external telegraph key is not used, withdraw interconnecting unit and jumper 4TB1-1 to ground. In either case, RF OUTPUT

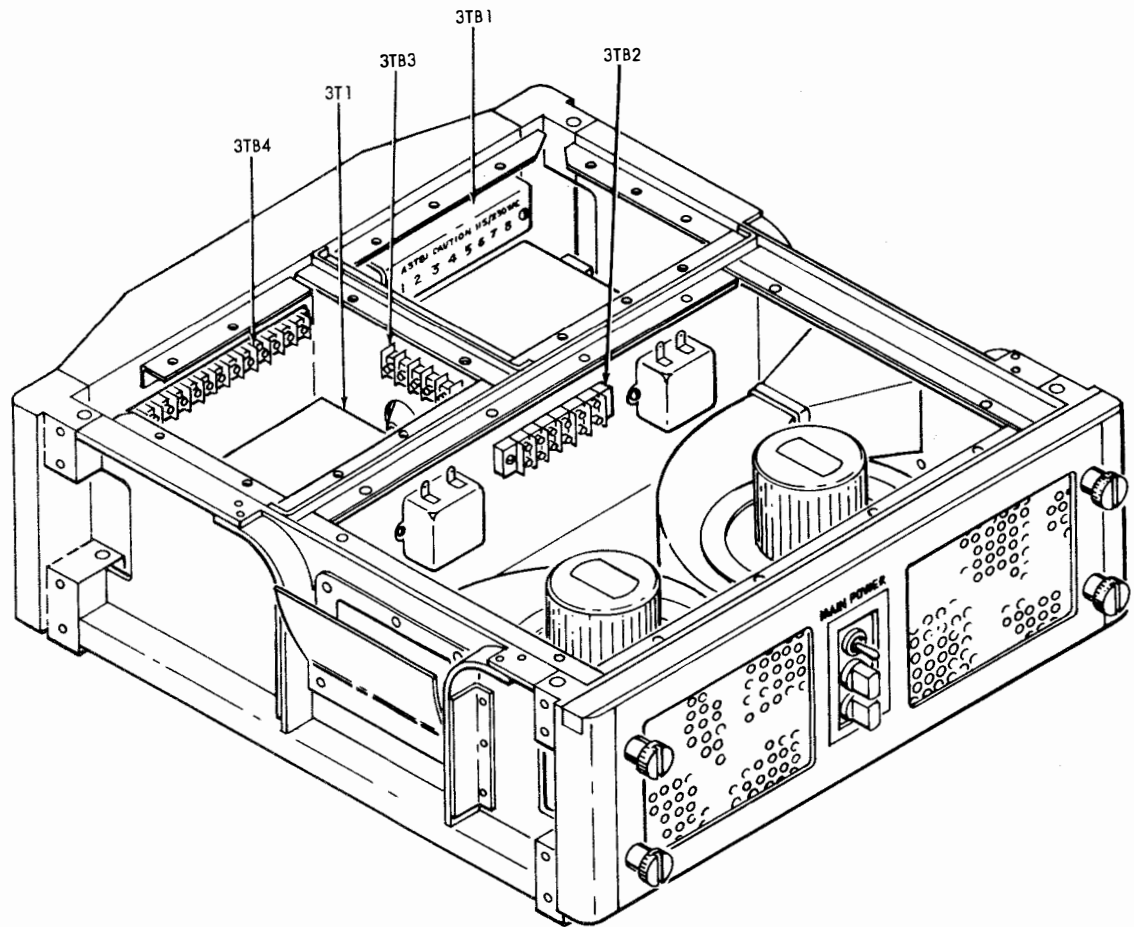

657-11

Figure 2-9. Electrical Equipment Cabinet CY-3022/WRA-3, Unit 3, Base Compartment

meter should read full scale. Remove jumper from 4TB1-1 to ground, if used, and secure interconnecting unit.

- Step 15. Turn RF DRIVE control to zero.
- Step 16. Perform applicable step (17 or 18) of paragraph 3-2b(1)(c).
- Step 17. Perform procedures of 3-2b(2)(b) or 3-2b(2)(c), whichever paragraph is applicable for installation, when transmitter group is used with larger equipment. If it is impossible to obtain proper operation of larger equipment when it is excited by the AN/WRA-3, contact maintenance personnel.

2-7. INTERFERENCE REDUCTION.

If the installation of the transmitter group is completed according to instructions, no objectionable interference should be radiated. Noise interference can be caused by a poor coaxial cable connection. To reduce possible interference, check all coaxial connections and tighten loose connectors.

2-8. EMERGENCY USE OF SYNTHESIZER OPERATING WITH 115 VOLT 400 CPS POWER INPUT.

Transmitter Group AN/WRA-3 is designed to use an electrical frequency synthesizer which operates from 115 volt 60 cps power source. However, in an emergency, a synthesizer (such as the O-1115/URC) which requires 115 volt 400 cps input power (as noted on the identification plate) may be used by performing the following steps.

NOTE

If following procedure is to be accomplished prior to reassembly of Transmitter Group AN/WRA-3, disregard steps 1 and 6.

- Step 1. Secure equipment (paragraph 3-2b(4)), then remove power supply from cabinet (paragraph 2-4b(1)).
- Step 2. Remove cover plate, base, left rear, from electrical equipment cabinet, as seen from power supply opening.
- Step 3. Locate wire 13 (figure 2-10) connected between terminals 3TB3-3 and 3TB3-5 (figure 2-9). Disconnect wire 13 from 3TB3-3 and connect to 3TB3-8.
- Step 4. Locate wire 14 (figure 2-10) connected between 3TB3-2 and 3TB3-4 (figure 2-9). Disconnect wire 14 from terminal 3TB3-2 and connect to 3TB3-7.
- Step 5. Replace cover plate removed in step 2.
- Step 6. Install power supply by performing, in reverse order of procedure, paragraph 2-4b(1).
- Step 7. Remove cover plate on electrical equipment cabinet external cable compartment (figure 2-8).
- Step 8. Pass 115 volt 400 cps, single-phase cable through one of packing glands on bottom of electrical equipment cabinet external cable compartment.
- Step 9. Connect wires of 115 volt 400 cps, single-phase cable to 3TB4-11 and 3TB4-12 (figure 2-8); connect shield to 3TB4-10.
- Step 10. Replace cover plate removed in step 7.

NOTE

The following condition now exists; no main power switch is provided for the 400 cps source other than the POWER switch located in Electrical Frequency Synthesizer O-1115/

URC. The synthesizer crystal oven cannot be turned off unless the 400 cps power source is deenergized external to the transmitter group. No main line fuse is provided for the 400 cps source other than the fuses located within the synthesizer. The 400 cps line will not have a line filter (for rf isolation) between the external line and interior of the electrical equipment cabinet.

2-9. RETURNING EQUIPMENT TO NORMAL CONFIGURATION AFTER EMERGENCY USE OF SYNTHESIZER.

To reconnect the transmitter group using an electrical frequency synthesizer which operates from 115 volt 60 cps power source, perform the following steps.

- Step 1. Disconnect 115 volt 400 cps power cable at power source.
- Step 2. Remove cover plate on electrical equipment cabinet external cable compartment (figure 2-8).
- Step 3. Disconnect 115 volt 400 cps power cable at 3TB4-10, -11, and -12 (figure 2-8).
- Step 4. Replace cover plate removed in step 2.
- Step 5. Refer to paragraph 2-4b(1) and remove power supply from cabinet.
- Step 6. Remove cover plate, base, left rear of electrical equipment cabinet as seen from power supply opening.
- Step 7. Disconnect wire 13 (figure 2-10) from 3TB3-8 (figure 2-9) and connect to 3TB3-3.
- Step 8. Disconnect wire 14 (figure 2-10) from 3TB3-7 (figure 2-9) and connect to 3TB3-2.
- Step 9. Replace cover plate removed in step 6.
- Step 10. Install power supply by performing, in reverse order and procedure, paragraph 2-4b(1).

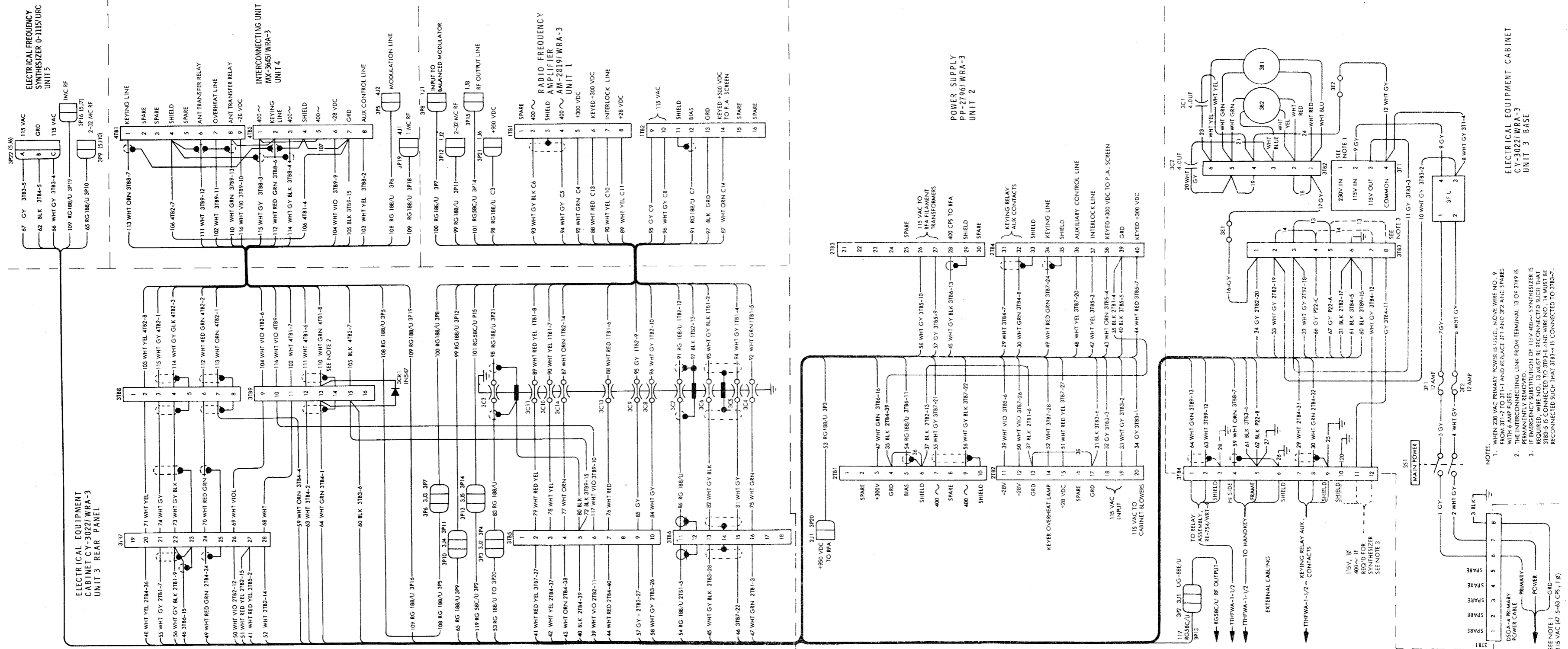

Figure 2-10. Transmitter Group AN/WRA-3, Interconnecting Cabling Diagram

SECTION 3
OPERATION

3-1. FUNCTIONAL OPERATION.

Transmitter Group AN/WRA-3 is a continuous wave (cw) transmitter primarily intended for use as an exciter for Radio Set AN/URC-32 and Radio Transmitting Set AN/WRT-2. However, it may also be used independently for direct transmission.

The transmitter group provides complete coverage, in five bands, of the frequencies in the 2 to 32 mc range. The equipment is capable of providing a nominal average power output of 15 watts when used as a separate transmitter and is 1.5 watts output when used as an exciter.

The transmitter group consists of seven separate units and an electronic equipment modification kit; namely: Electrical Frequency Synthesizer O-1115/URC(GFM), Interconnecting Unit MX-3645/WRA-3, Radio Frequency Amplifier AM-2819/WRA-3, Power Supply PP-2796/WRA-3, Electrical equipment Cabinet CY-3022/WRA-3, Resilient Mount MT-2661/WRA-3, Relay Assembly RE-754/WRT-4, and Modification Kit MK-846/WRA-3.

Three of these seven units (synthesizer, radio frequency amplifier, and power supply) require the attention of the operator. Two of the remaining units (interconnecting unit and cabinet) provide terminating points for interunit cable connections.

The resilient mount provides part of the mounting facilities for the cabinet and the relay assembly and modification kit are used only when the transmitter group is used with auxiliary equipment. Refer to NAVSHIPS 0967-047-7010 for auxiliary equipment details.

The operation of the equipment is similar to that of any conventional cw transmitter. The electrical frequency synthesizer generates a radio frequency in the 2 to 32 mc range. The synthesizer output is applied to the radio frequency amplifier to be amplified and keyed. The output of the rf amplifier can either be applied directly to an antenna and transmitted, or it can be applied to the rf amplifier of a larger transmitter (AN/URC-32 or AN/WRT-2) for amplification to a higher power level.

3-2. OPERATING PROCEDURES.

a. DESCRIPTION OF CONTROLS. -- Controls for the operation of the transmitter group are located on the unit front panels, as shown in figures 3-1 through 3-4. Tables 3-1 through 3-4 list the controls and indicators and their functions.

b. SEQUENCE OF OPERATION. -- The normal sequence of operation for the transmitter group

before use, during use, standby, and secure is given in the following paragraphs.

(1) BEFORE USE.

(a) MOD OPERATION. - MOD operation is used only with auxiliary equipment. Refer to NAVSHIPS 0967-047-7010 for details.

(b) CW OPERATION. -- Before turning on the transmitter group, perform the following steps.

NOTE

If auxiliary equipment is installed, refer to NAVSHIPS 0967-047-7010 for cw operation.

- Step 1. Open radio frequency amplifier drawer by loosening four large captive screws on front panel; pull out unit on slides until slide locks engage.
- Step 2. Connect 1P4 to 1J7 (figure 3-5) if not already connected to 1J7. Leave radio frequency amplifier extended and proceed to step 3.
- Step 3. Place cw-mod switch 1S6 in cw position.
- Step 4. If output mode is direct transmission, proceed to paragraph 3-2b(1)(b)1. If mode of transmission is excitation, proceed to paragraph 3-2b(1)(b)2.

1. DIRECT TRANSMISSION (15 WATTS POWER OUTPUT).

- Step 1. Connect 1P5 and 1P6 to 1J5 (figure 3-5). Note that connectors 1P5 and 1P6 may already be connected to 1J5.
- Step 2. Close and secure radio frequency amplifier drawer by pressing SLIDE RELEASE buttons above handles while pushing unit into cabinet, then securing four captive screws.
- Step 3. Connect rf output cable from electrical equipment cabinet connector 3J1 (figure 2-8) to suitable antenna or antenna coupler.

2. EXCITATION (FOR LARGER EQUIPMENT).

- Step 1. Connect rf attenuator of radio frequency amplifier by connecting 1P6 to 1J11 and 1P5 to 1J10 (figure 3-5).

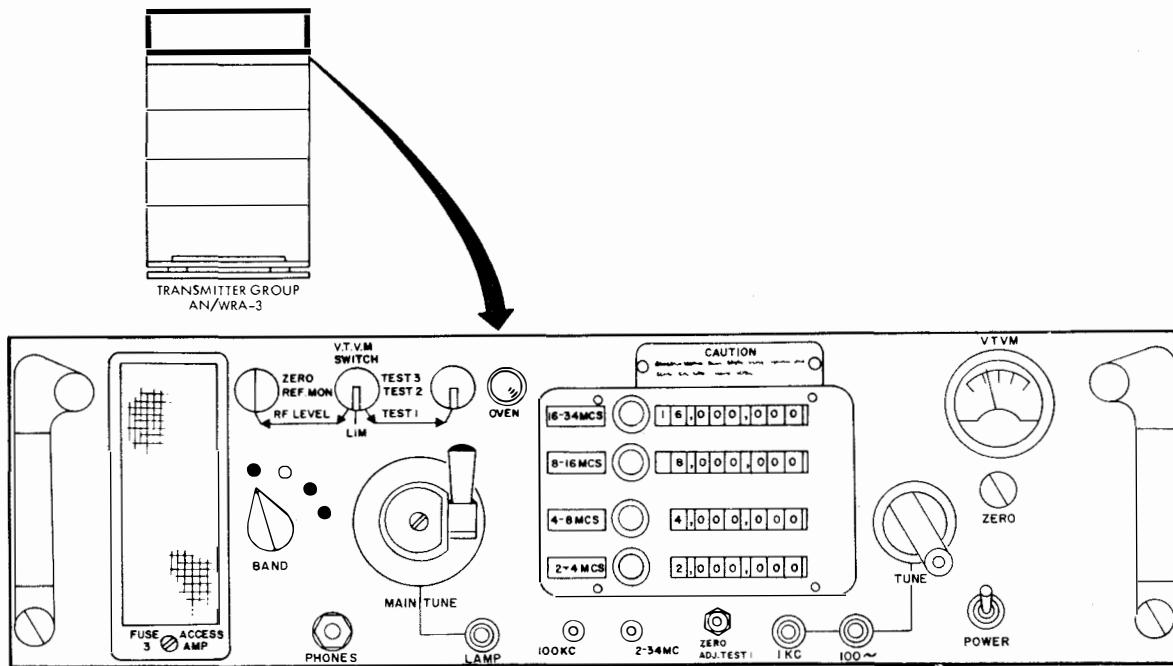

657-13

Figure 3-1. Electrical Frequency Synthesizer O-1115/URC, Unit 5,
Front Panel Controls and Indicators

- Step 2. Close and secure radio frequency amplifier drawer by pressing SLIDE RELEASE buttons above handles while pushing unit into cabinet, then securing four captive screws.
- Step 3. Connect rf output cable from electrical equipment cabinet connector 3J1 (figure 2-8) to applicable equipment. If the AN/WRT-2 equipment is used, connect directly to transmitter. If the AN/URC-32 equipment is used, connect directly to Transmitter Transfer Control C-6562/WRA-3 (part of Modification Kit MK-846/WRA-3).

(c) STARTING TRANSMITTER GROUP
AN/WRA-3.

- Step 1. Power supply FILAMENT and LOW VOLTAGE switches must be in OFF position, (figure 3-3).
- Step 2. Place MAIN POWER switch in ON position (located on front panel of electrical equipment cabinet), figure 3-4. Electrical frequency synthesizer OVEN

lamp should light, (figure 3-1). If not warmed up, OVEN lamp stays lit 30 minutes. When crystal oven reaches correct temperature, OVEN lamp should cycle on and off every 40 seconds.

- Step 3. Place electrical frequency synthesizer POWER switch in on position (up). Synthesizer blower should operate and dial illuminate.

NOTE

Electrical Frequency Synthesizer O-1115/URC requires one hour warmup for best frequency stability. (For detailed information, refer to NAVSHIPS 94829.)

- Step 4. Set electrical frequency synthesizer BAND switch to desired band position.
- Step 5. Set electrical frequency synthesizer controls to desired frequency. As these controls are set, frequency is displayed on digital readout for selected band (indicated by a light).

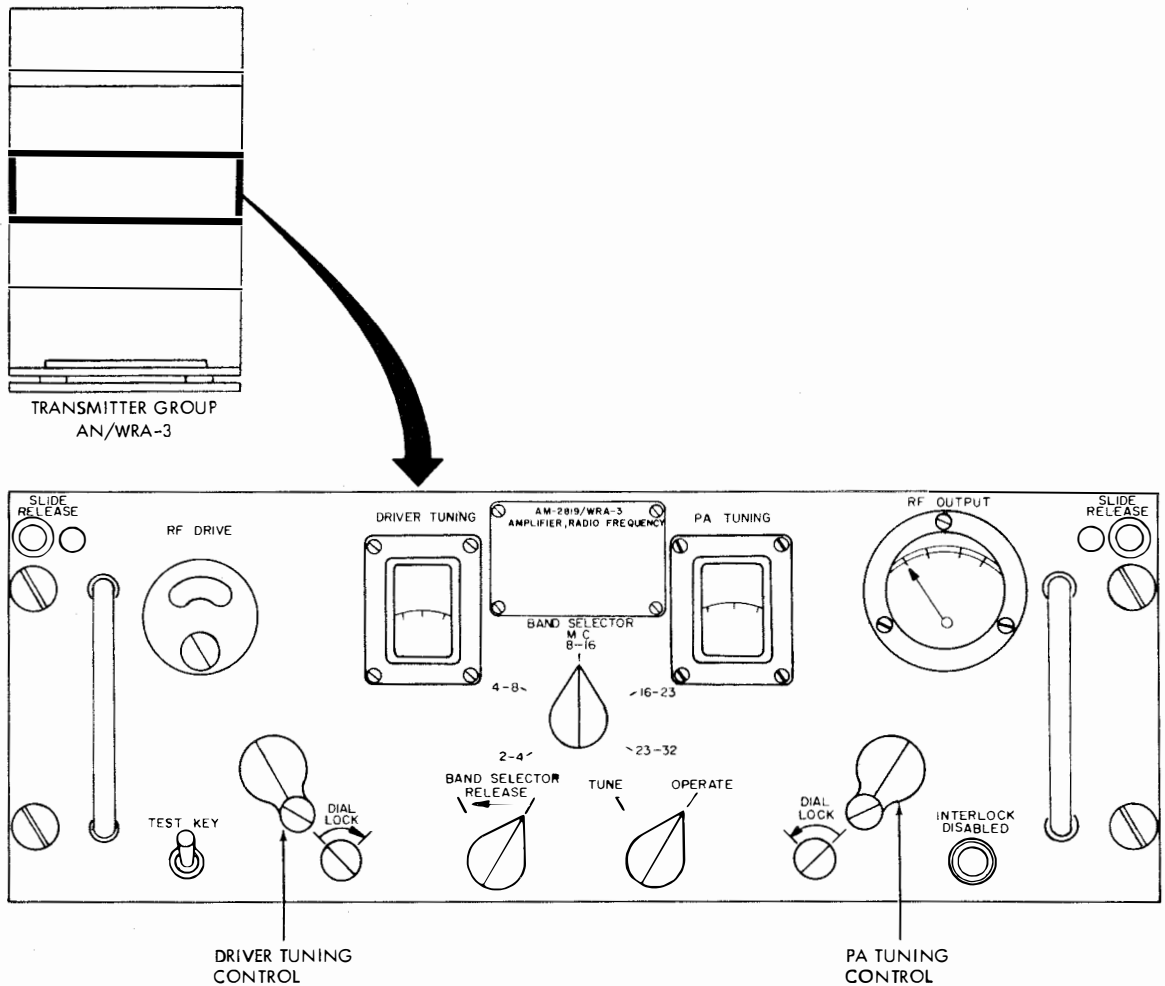

657-14

Figure 3-2. Radio Frequency Amplifier AM-2819/WRA-3, Unit 1, Front Panel Controls and Indicators

NOTE

Main tune control handle must be collapsed to detent position. Both detent lamps blink for about one minute after turning on electrical frequency synthesizer. After that time, they must be dark to indicate that the two frequency controls are properly set in their detents.

- Step 6. Set VTVM switch on synthesizer to R. F. LEVEL position. Adjust R. F. LEVEL control to VTVM reading of 2.0 volts.
- Step 7. Set radio frequency amplifier BAND

SELECTOR (Figure 3-2) to desired band.

- Step 8. Set radio frequency amplifier BAND TUNING and PA TUNING to desired frequency.
- Step 9. Place power supply FILAMENT switch in ON position. FILAMENT lamp and tuning dial lamps on rf amplifier should light. Blowers should operate (audibly detected). Check that no fuse blown lamps are lighted.
- Step 10. Place power supply LOW VOLTAGE

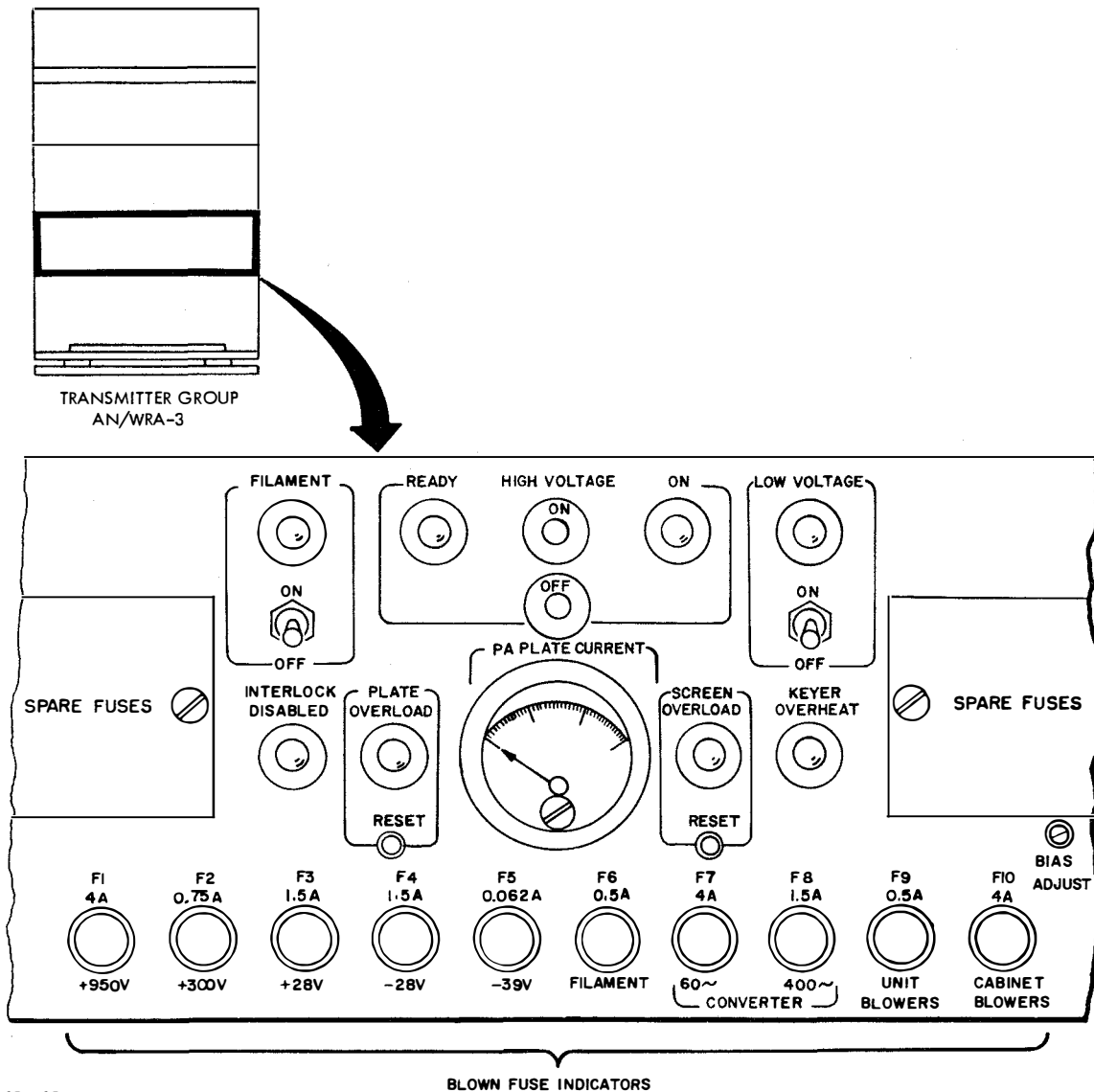

657-15

Figure 3-3. Power Supply PP-2796/WRA-3, Unit 2,
Front Panel Controls and Indicators

switch in ON position. LOW VOLTAGE lamp lights. READY lamp should light if FILAMENT switch has been placed in ON position for at least 30 seconds. Check that no fuse blown lamps are lighted.

Step 11. Place radio frequency amplifier TUNE OPERATE switch in TUNE position. Turn R. F. DRIVE to 0 position.

Step 12. When power supply READY lamp lights, push HIGH VOLTAGE ON switch. HIGH VOLTAGE ON lamp lights and READY lamp goes out.

NOTE

After high voltage circuit is energized, operation of TUNE OPERATE or BAND

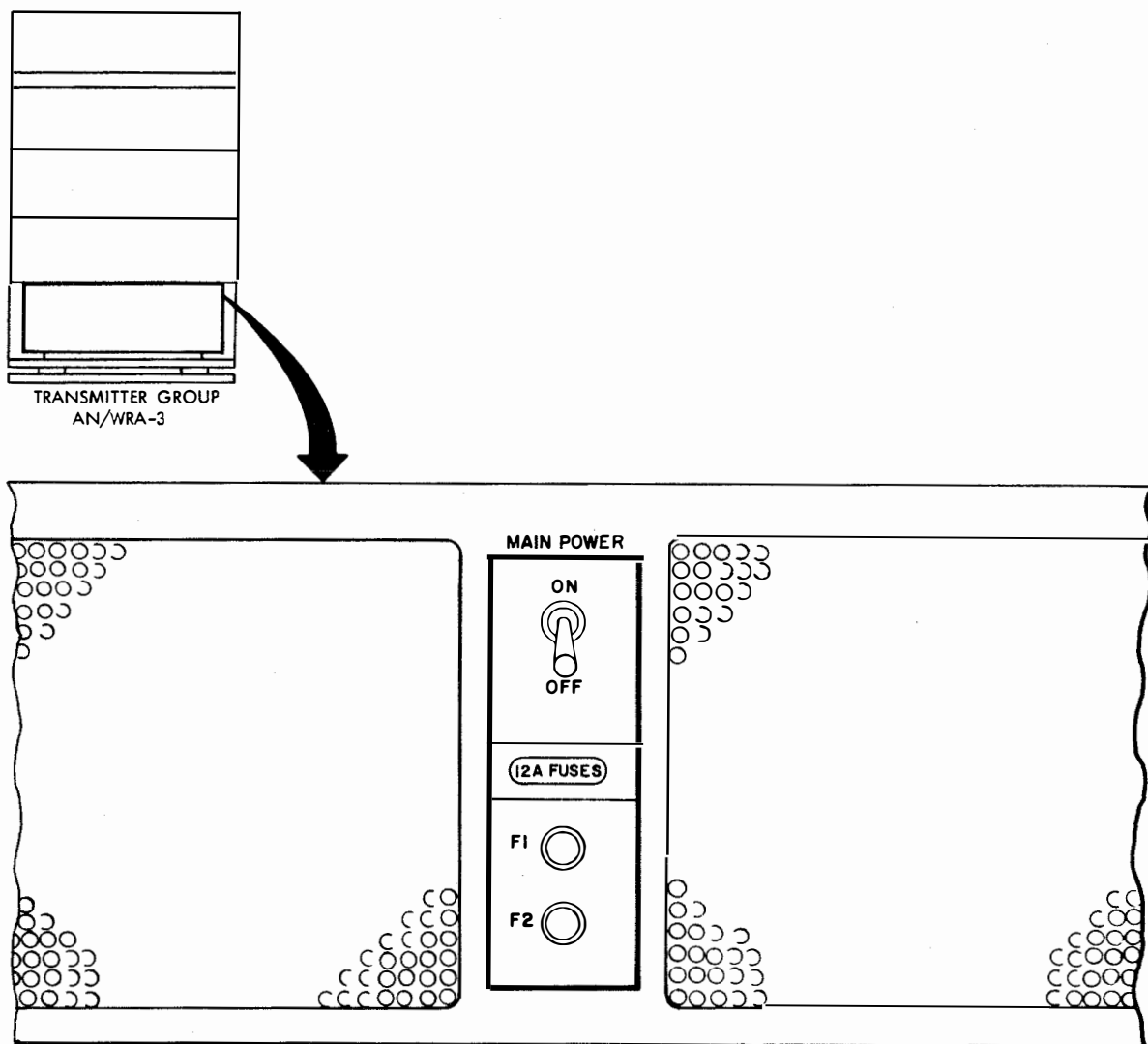

657-16

Figure 3-4. Electrical Equipment Cabinet CY-3022/WRA-3, Unit 3,
Front Panel Controls and Indicators

SELECTOR RELEASE controls deenergizes high voltage circuit. The HIGH VOLTAGE ON pushbutton must be pressed again to obtain high voltage.

produce peak indication on RF OUTPUT meter. If needle goes above 3/4 scale, reduce setting of RF DRIVE control, and again tune for peak indication.

Step 13. Place radio frequency amplifier TEST KEY in locking position (up) and adjust RF DRIVE for reading of about one-third scale on RF OUTPUT meter.

Step 14. Adjust radio frequency amplifier DRIVER TUNING and PA TUNING to

NOTE

PLATE OVERLOAD or SCREEN OVERLOAD lamps should light when corresponding protective relays trip. When either of these lamps light, HIGH VOLTAGE ON lamp should go out. To reset, turn RF DRIVE to

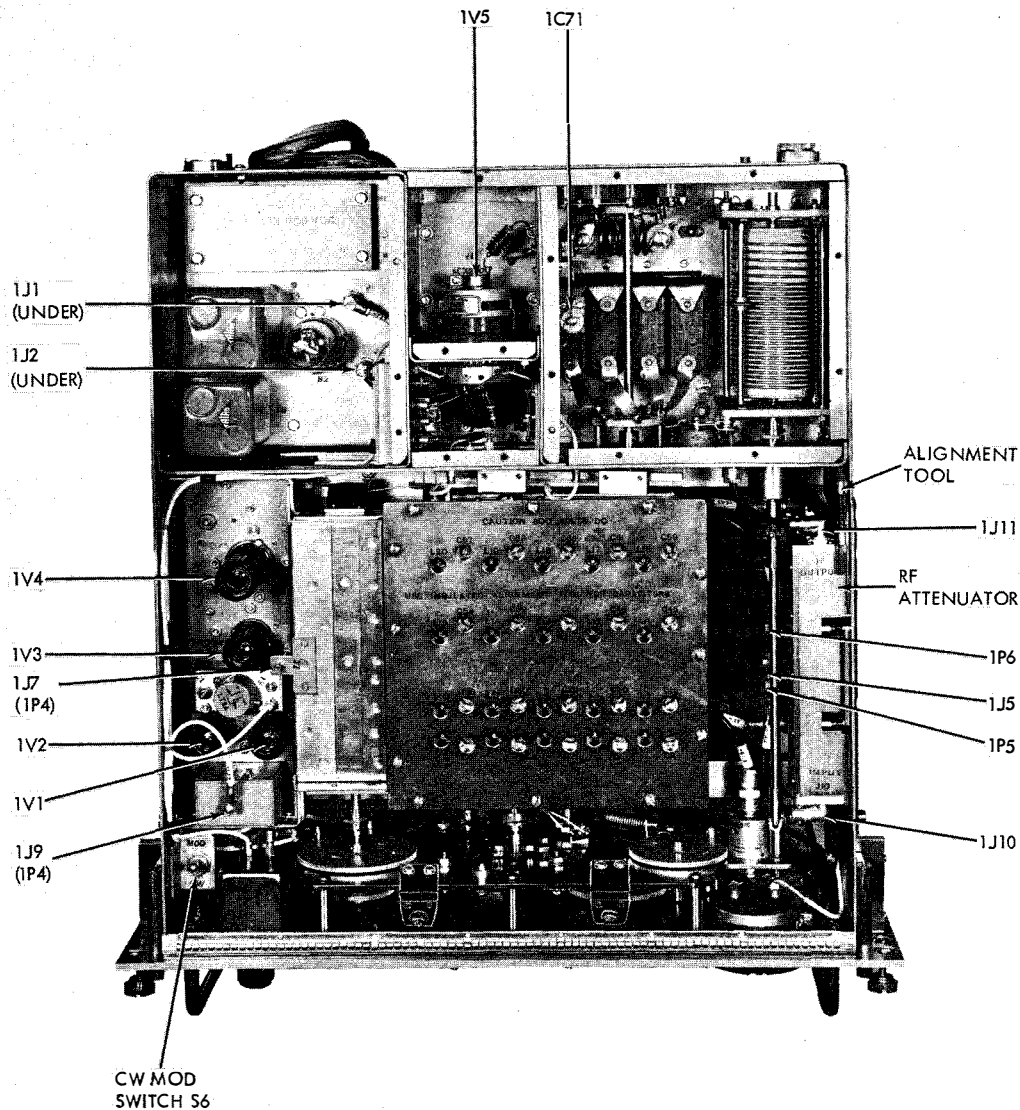

Figure 3-5. Radio Frequency Amplifier AM-2819/WRA-3, Unit 1, Top View

0 position, press RESET button below glowing OVERLOAD lamp, then press HIGH VOLTAGE ON button. If OVERLOAD lamps light repeatedly, contact maintenance personnel.

ON pushbutton. The transmitter group is now tuned to transmit at the desired frequency.

CAUTION

Equipment may be damaged if rf output load is disconnected and equipment is keyed in OPERATE mode.

Step 15. Turn radio frequency amplifier RF DRIVE to 0 position.

Step 16. Check rf output connection to associated equipment, to be sure that normal load is connected. Press TEST KEY of radio frequency amplifier down and release. Turn TUNE OPERATE switch to OPERATE position. Push HIGH VOLTAGE

Step 17. If transmitter group is to be used for direct transmission, tune antenna, then press radio frequency amplifier TEST KEY and adjust RF LEVEL for full-scale indication on RF OUTPUT meter. Operate telegraph key.

Step 18. If transmitter group is to be used to excite the AN/WRT-2 or AN/URC-32, perform procedure for starting larger equipment, given in applicable paragraph which follows.

(d) STARTING RADIO TRANSMITTING SET AN/WRT-2. (All controls located on the front panel of AN/WRT-2.) Refer to NAVSHIPS 93319(A).

- Step 1. Place power supply EMERGENCY STOP switch in ON position.
- Step 2. Place amplifier-power supply FILAMENT POWER to ON, POWER SELECTOR to ADJ, EMISSION SELECTOR to CW, press PLATE POWER ON, and place LOCAL-REMOTE to LOCAL.
- Step 3. Place radio frequency amplifier CARRIER TEST KEY to OFF, P.A. CATHODE CURRENTS to TOTAL, and TUNER CONTROL to 1KC STEPS.
- Step 4. Place radio frequency amplifier COUPLER ANTENNA control to position best suited for frequency of transmission. Refer to the following:

- 2.0 to 4.0 mc: DIRECT
- 3.5 to 4.5 mc: B
- 4.0 to 5.0 mc: A
- 4.5 to 6.5 mc: DIRECT
- 5.5 to 7.5 mc: Set TUNER CONTROL to BYPASS position.
- 7.0 to 32.0 mc: DIRECT

(e) STARTING RADIO SET AN/URC-32. (All controls located on front panel of AN/URC-32.) -- Refer to NAVSHIPS 93285(A).

- Step 1. Place low voltage power supply ON-OFF switch in ON position.
- Step 2. Place power amplifier FIL OFF-TUNE-OPERATE switch in OPERATE position.
- Step 3. After 30 seconds, place power amplifier PLATE switch in ON position.
- Step 4. Place antenna tuner ANT-LOAD switch to LOAD.

(2) DURING USE.

(a) ADJUSTMENTS FOR ELECTRICAL FREQUENCY SYNTHESIZER O-1115/URC. (See figure 3-1.) -- The following adjustments should be made at least once each time the synthesizer is turned on or tuned to a new frequency. The synthesizer should be turned on at least one hour before proceeding.

- Step 1. Approximately 10 minutes after starting

equipment, set BAND switch to band that includes desired output frequency. Full frequency range and steps of each band are as follows:

Band 1: 16 to 34 mc in 100 cycle steps

Band 2: 8 to 17 mc in 50 cycle steps

Band 3: 4 to 8.5 mc in 25 cycle steps

Band 4: 2 to 4.25 mc in 12.5 cycle steps

- Step 2. Set TEST 1 control so that white indicator line on knob is vertical.
- Step 3. Rotate MAIN TUNE control to select 10 kc and higher digits of desired frequency, indicated on counters of selected band. For quick rotation of MAIN TUNE control, lift up handle and rotate rapidly. After selecting first four digits of output frequency, turn rapid MAIN TUNE control handle down.

NOTE

When tuning controls are rotated, respective indicator lamps will light. However, as soon as tuning controls are returned to detent, indicator lamps will extinguish.

- Step 4. Rotate TUNE (1 KC) control to select 1 kc digit of desired frequency. Then turn TUNE (100~) control for remaining desired digits. The TUNE (1 KC) and TUNE (100~) controls are concentric and operate together.

NOTE

When TUNE (1 KC) control is turned rapidly, TUNE (100~) control tends to return to nearest stop. Therefore, when TUNE (1 KC) control is used, check frequency setting on counter.

- Step 5. Turn VTVM switch to ZERO position and zero adjust VTVM with ZERO control.
- Step 6. Turn VTVM switch to LIM position. Simultaneously depress ZERO ADJ TEST 1 switch and adjust TEST 1 control for maximum indication on VTVM.
- Step 7. Turn VTVM switch to TEST 1 position. Depress ZERO ADJ TEST 1 switch and adjust TEST 1 control for null (zero). Release ZERO ADJ TEST 1 switch and VTVM should remain at null.

Step 8. Turn VTVM switch to TEST 2, TEST 3, and TEST 4 positions, respectively. Indication of VTVM for each setting should be 0 ± 1 volt. If necessary, obtain correct voltages at TEST 2 and TEST 3 positions by adjusting capacitors C1506 and C1806, respectively, available through holes in bottom cover. Refer to NAVSHIPS 94829 for details. Obtain correct voltage at TEST 4 position by adjusting capacitor C1906, accessible through hole in top cover.

Step 9. Turn VTVM switch to LIM position and check that voltage is between -1 and -5 volts. If voltage is not within specified range, notify maintenance personnel.

Step 10. Turn VTVM switch to RF LEVEL position. Adjust VTVM reading to 2.0 volts with RF LEVEL control.

NOTE

VTVM scale is calibrated for rf output only when synthesizer is terminated in 50-ohm load.

(b) ADJUSTMENTS FOR RADIO TRANSMITTING SET AN/WRT-2. -- When Transmitter Group AN/WRA-3 is used to excite the AN/WRT-2, proceed as follows.

NOTE

Capital letters, enclosed in circle, are front panel markings of the AN/WRT-2.

- Step 1. Set transmitter excitation INT-EXT switch (on Transmitter Transfer Control C-6562/WRA-3) to EXT position.
- Step 2. Place Amplifier-Power Supply AM-2122/WRT-2 LOCAL REMOTE switch at REMOTE, and turn DRIVE ADJUST control (located on front panel of Radio Frequency Amplifier AM-2121/WRT-2) fully ccw.
- Step 3. Place TUNE-COUP control to TUNE position and set I.P.A. TUNING (F) and P.A. TUNING (G) to assigned frequency.
- Step 4. Place TUNE-COUP control in COUP position, set I.P.A. FINE TUNING to 5, P.A. COUPLING (H) to 50, and DRIVE ADJUST to zero.
- Step 5. Place OUTPUT METER switch to R-F OUTPUT and TEST AMMETER to P.A. POS. SCREEN CURRENT.
- Step 6. Place CARRIER TEST KEY in ON position.

Step 7. On AN/WRA-3, place TEST KEY in locking position (up) and set Radio Frequency Amplifier AM-2819/WRA-3 RF DRIVE control to produce a reading of .25 on RF OUTPUT meter.

Step 8. Adjust I.P.A. TUNING (F) and I.P.A. FINE TUNING controls (on Radio Frequency Amplifier AM-2121/WRT-2) for peak reading on TEST AMMETER. On AN/WRA-3, set RF DRIVE control to keep TEST AMMETER needle between green scale lines.

Step 9. On AN/WRA-3, set RF DRIVE control to 0.

Step 10. Place POWER SELECTOR switch (on Amplifier-Power Supply AM-2122/WRT-2) at TUNE position.

Step 11. On AN/WRA-3, adjust RF DRIVE control until, on AN/WRT-2, a reading of 600 ma is obtained on Radio Frequency Amplifier AM-2121/WRT-2 PA CATHODE CURRENT meter (or 100 watts on R-F OUTPUT meter, whichever happens first).

Step 12. Place TUNE-COUP control (Radio Frequency Amplifier AM-2121/WRT-2) in TUNE position, and adjust P.A. TUNING (G) for peak reading on RF OUTPUT meter. Reduce AN/WRA-3 RF DRIVE if necessary to keep output below 100 watts (on RF OUTPUT meter on AN/WRT-2).

Step 13. Place POWER SELECTOR control (Amplifier-Power Supply AM-2122/WRT-2) in 100 W position.

Step 14. On Radio Frequency Amplifier AM-2121/WRT-2 alternately press POSITION CONTROL UP (K) and DOWN (L) buttons for peak reading on R-F OUTPUT meter.

Step 15. Press SLOW READ SWR (M) button and alternately press POSITION CONTROL UP (K) and DOWN (L) buttons for most leftward indication on SWR INDICATOR scale. (Keep needle on scale with SWR CALIBRATE control.)

Step 16. Adjust P.A. TUNING (G) control for peak on RF OUTPUT meter.

Step 17. Place POWER SELECTOR switch (on Amplifier-Power Supply AM-2122/WRT-2) in 500 W position.

CAUTION

TOTAL P.A. CATHODE CURRENT MUST

NOT EXCEED 825 ma for 500 watt output. TOTAL P.A. CATHODE CURRENT MUST NOT EXCEED 500 ma for no output. If these current limits are exceeded, repeat steps 8 through 15.

- Step 18. On AN/WRA-3, adjust RF DRIVE for 500 watt reading on R-F OUTPUT METER (on Radio Frequency Amplifier AM-2121/WRT-2). Alternately adjust P.A. COUPLING (H) and P.A. TUNING (G) until 500 watts is obtained with less than 15 ma on TEST AMMETER switch in P.A. NEG SCREEN CURRENT position. When P.A. CATHODE CURRENTS switch is in TOTAL position, P.A. CATHODE CURRENTS meter should read from 700 to 750 ma.
- Step 19. Place CARRIER TEST KEY in OFF position. On Amplifier-Power Supply AM-2122/WRT-2, place LOCAL REMOTE switch at REMOTE. On AN/WRA-3, press and release TEST KEY. The AN/WRT-2 is now adjusted to transmit output of the AN/WRA-3. For standby, press HIGH VOLTAGE OFF button (on Power Supply PP-2796/WRA-3), and PLATE POWER OFF button (on Amplifier-Power Supply AM-2122/WRT-2).

NOTE

For independent operation or adjustment of Radio Transmitting Set AN/WRT-2, with Transmitter Transfer Control C-6562/WRA-3 installed, the following must be performed:

- 1) Set RF DRIVE control of Radio Frequency Amplifier AM-2819/WRA-3 to 0.
- 2) Push HIGH VOLTAGE OFF pushbutton of Power Supply PP-2796/WRA-3.
- 3) Set WRT-2/WRA-3 switch of transmitter transfer control to WRT-2 position.
- 4) Refer to NAVSHIPS 93319(A) for normal adjustment and operating procedures of the AN/WRT-2 for independent operation.

Transmitter Group AN/WRA-3 can be deenergized, if desired, when the AN/WRT-2 is operating as an independent transmitter. If using facility requires immediate availability of the AN/WRT-2, leave transmitter transfer control set to INT-WRT-2.

(c) ADJUSTMENTS FOR RADIO SET AN/URC-32. -- When the AN/WRA-3 output is used to excite the AN/URC-32, proceed as follows.

- Step 1. Set transmitter excitation switch (on Transmitter Transfer Control C-6562/WRA-3) to EXT - WRA-3 position. Set EXCITER RF GAIN control on Sideband Generator 786F-1 of the AN/URC-32 to maximum ccw position.
- Step 2. Set FIL OFF-TUNE-OPERATE switch (on Power Amplifier 367A-3) to TUNE position.
- Step 3. Place PLATE switch (Power Amplifier 367A-1) in KEY position.
- Step 4. On AN/WRA-3, place TEST KEY in locking position (up) and adjust RF DRIVE (on Radio Frequency Amplifier AM-2819/WRA-3) to produce reading of 200 ma on PLATE CURRENT meter (Power Amplifier 367A-1).
- Step 5. Adjust DRIVER TUNE (on Power Amplifier 367A-1) for peak on PLATE CURRENT meter. (Keep PLATE CURRENT meter reading below 200 ma by adjusting RF DRIVE (on Radio Frequency Amplifier AM-2819/WRA-3). Detune P.A. TUNE for zero power output indication on antenna tuner RF meter. Readjust DRIVER TUNE control for peak. Do not change setting during rest of tuning procedure. Set PLATE switch in ON position.
- Step 6. Set P.A. TUNE (On Power Amplifier 367A-1) to assigned frequency according to applicable tuning chart (refer to NAVSHIPS 93285(A)). Place PLATE switch in KEY position, and adjust P.A. TUNE for dip in PLATE CURRENT meter indication. Set PLATE switch in ON position.
- Step 7. On AN/WRA-3, turn RF DRIVE control (on Radio Frequency Amplifier AM-2819/WRA-3) to 0 position.
- Step 8. Set FIL OFF-TUNE-OPERATE switch (on Power Amplifier 367A-2) to OPERATE position.
- Step 9. Place PLATE switch in KEY position, and on the AN/WRA-3, adjust RF Drive for 500 watt output, as indicated on antenna tuner RF meter. Set PLATE switch in ON position. Set LOCAL-REMOTE switch in REMOVE position. On AN/WRA-3, press and release TEST KEY. Radio Set AN/URC-32 is now ready to transmit output of the AN/WRA-3.

NOTE

For independent operation of adjustment

of Radio Set AN/URC-32, with Transmitter Transfer Control C-6562/WRA-3 installed, the following must be performed:

- 1) Set RF DRIVE control of Radio Frequency Amplifier AM-2819/WRA-3 to 0.
- 2) Push HIGH VOLTAGE OFF pushbutton of Power Supply PP-2796/WRA-3.
- 3) Set URC-32 WRA-3 switch of transmitter transfer control to URC-32.
- 4) Refer to NAVSHIPS 93285(A) for normal adjustment and operating procedures of the AN/URC-32 for independent operation.

Transmitter Group AN/WRA-3 can be deenergized, if desired, when an AN/URC-32 is operating as an independent transmitter. If using facility requires immediate availability of the AN/URC-32, leave transmitter transfer control set to INT-URC-32.

(3) STANDBY. -- For local standby operation of the AN/WRA-3, push the power supply HIGH VOLTAGE OFF pushbutton. On the AN/WRT-2, press PLATE POWER OFF pushbutton. On the AN/URC-32, place the PLATE switch in the OFF position.

For long standby, secure the equipment as described in the next paragraph except for steps 3 and 4. (Leave the MAINPOWER switch in the ON position and leave the electrical frequency synthesizer POWER switch in the on position (up)).

(4) SECURE.

(a) TRANSMITTER GROUP AN/WRA-3.

- Step 1. Place LOW VOLTAGE switch in OFF position (power supply).
- Step 2. After 3 minutes, place FILAMENT switch in OFF position.
- Step 3. Place MAIN POWER switch in OFF position (located on cabinet base front panel).
- Step 4. Place electrical frequency synthesizer POWER switch in off position (down).
- Step 5. Secure larger transmitter by procedure given in following applicable paragraph.

(b) RADIO TRANSMITTING SET AN/WRT-2.

- Step 1. Press PLATE POWER OFF switch (on Amplifier-Power Supply AM-2122/WRT-2).

- Step 2. Place FILAMENT POWER switch to OFF.
- Step 3. Place EMERGENCY STOP switch to OFF (on Power Supply PP-2222/WRT).

(c) RADIO SET AN/URC-32.

- Step 1. Place PLATE switch to OFF (on Power Amplifier 367A).
- Step 2. Place FIL OFF-TUNE-OPERATE switch to FIL OFF.
- Step 3. Place ON-OFF switch to OFF (on Low Voltage Power Supply 429B-1).

3-3. SUMMARY OF OPERATING PROCEDURES.

After the operator is familiar with the controls and the operation of the transmitter group and associated equipment, operation will become routine. Table 3-5 is provided as a summary of operating procedures. The summary includes those instructions necessary to operate the AN/WRT-2 and the AN/URC-32 equipments in conjunction with the AN/WRA-3. (For further information regarding these equipments, refer to NAVSHIPS 93319(A) for the AN/WRT-2, or NAVSHIPS 93285(A) for the AN/URC-32).

3-4. EMERGENCY OPERATION.

In the event the main cabinet blowers fail, the transmitter group can be operated by opening radio frequency amplifier and power supply drawers to increase air circulation, providing drawer interlock switches are defeated.

3-5. OPERATOR'S MAINTENANCE.

a. OPERATING CHECKS AND ADJUSTMENTS.

-- The following checks should be made during each period of operation.

- Step 1. Place transmitter group in standby. Place radio frequency amplifier TUNE OPERATE switch in TUNE position. Check that following power supply lamps are lighted: FILAMENT, LOW VOLTAGE, and READY. Check that synthesizer OVEN lamp cycles on and off.
- Step 2. Place electrical frequency synthesizer BAND switch at each of its positions. At each position, check that lamp lights in window displaying band frequency.
- Step 3. Turn radio frequency amplifier RF DRIVE counterclockwise to 0 position. Press power supply HIGH VOLTAGE ON pushbutton and switch TEST KEY up. READY lamp goes out. Check that power supply HIGH VOLTAGE ON lamp

lights, and that PA PLATE CURRENT meter indicates approximately 190 to 220 ma with hand key or TEST KEY closed.

- Step 4. Replace any lamps that did not light correctly during steps 1 through 3. (Refer to paragraph 3-5b(1)).
- Step 5. Recheck any lamp that has been replaced. If lamp still does not light (as described in steps 1 through 3), contact maintenance personnel.
- Step 6. Check power supply blown fuse indicators. Replace any fuse indicated as blown (refer to paragraph 3-5b(2)).
- Step 7. Turn radio frequency amplifier RF DRIVE CONTROL to produce full scale reading on RF OUTPUT meter.
- Step 8. Read radio frequency amplifier PA PLATE CURRENT meter. If indication is more than 220 ma, contact maintenance personnel.
- Step 9. Release hand key or TEST KEY operated in step 3. Press HIGH VOLTAGE OFF switch. Return TUNE OPERATE switch to OPERATE position.

b. EMERGENCY MAINTENANCE.

(1) REPLACING INDICATOR LAMPS.*

- Step 1. Unscrew lamp cover with lens.
- Step 2. Press lamp in and twist counterclockwise to remove.
- Step 3. Press new lamp into socket and twist clockwise to secure
- Step 4. Screw on lamp cover with lens.

(2) REPLACING FUSES.*

- Step 1. Grasp transparent cover of blown fuse indicator, press and twist counterclockwise to remove fuse holder.
- Step 2. Remove blown fuse from clip in fuse holder.
- Step 3. Obtain new fuse of correct rating (as marked on front panel below blown fuse indicator).
- Step 4. Place new fuse in clip in fuse holder.
- Step 5. Align fuse holder to insert in socket. Press in and twist clockwise to secure.

(3) REPLACING VACUUM TUBES.*

(a) SYMPTOMS OF TUBE FAILURE. -- A common cause for malfunction is tube failure. When a malfunction occurs, first check for improperly set controls and for blown fuses. To check the tubes, open the radio frequency amplifier drawer. To do this, loosen four large captive screws on front panel, and pull unit out on its slides. Place power supply MAIN POWER and FILAMENT switches in the ON position. Check V1 through V4 (figure 3-5) to see if filaments glow. Replace any tube that does not glow. If test equipment is not available, tubes can be checked further by substitution, using new tubes in place of the old until malfunction is corrected.

(b) POWER AMPLIFIER TUBE. -- Do not replace power amplifier tube 1V5 (figure 3-5). Maintenance personnel are required to replace 1V5.

c. ROUTINE CHECK CHARTS. -- For preventive maintenance to be performed by the operator, refer to Maintenance Standards Book for Transmitter Group AN/WRA-3, NAVSHIPS 0967-031-9030.

*Refer to NAVSHIPS 94829 for synthesizer lamp, fuse, and vacuum tube replacement.

TABLE 3-1. ELECTRICAL FREQUENCY SYNTHESIZER O-1115/URC, UNIT 5
OPERATING CONTROLS AND INDICATORS

CONTROL OR INDICATOR	FUNCTION
POWER switch	Applies or removes input a-c power.
BAND switch	Selects one of four bands of output frequencies: 16 to 34 mc, 8 to 17 mc, 4 to 8.5 mc, or 2 to 4.25 mc.
MAIN TUNE control	Selects first four digits of output frequency.
MAIN TUNE indicator lamp	Indicates that MAIN TUNE control is in detent to assure accurate positioning of control, correct output frequency, and that synthesizer is frequency locked.
TUNE (1 KC) control	Selects fourth digit of output frequency.
1 KC indicator lamp	Indicates TUNE (1 KC) control is in detent to assure accurate positioning of control, correct output frequency, and that synthesizer is frequency locked.
TUNE (100~) control	Selects final three digits of output frequency.
100~ indicator lamp	Indicates that TUNE (100~) control is in detent to assure correct positioning of control, correct output frequency, and that synthesizer is frequency locked.
OVEN indicator lamp	Lights when oven heater is energized and extinguishes when correct oven temperature is reached.
VTVM meter	Monitors r-f output level, phase correction voltages, and i-f voltage.
ZERO control	Zero sets VTVM.
VTVM switch	Selects any one of eight operating modes for VTVM.
ZERO position	Allows VTVM to be zero set with ZERO control.
LIM position	Second i-f output level is read on VTVM.
REF MON position	Relative phase error between internal and external oscillators is read on VTVM.
RF LEVEL position	R-f output level is read on VTVM and RF LEVEL control may be adjusted for proper VTVM reading.
TEST 1 position	Main vfo phase-correction voltage is read on VTVM and can be properly adjusted by TEST 1 control.
TEST 2 position	Phase-correction voltage of 10-kc vfo is read on VTVM and can be adjusted by capacitor C1506 (accessible through bottom cover).
TEST 3 position	Phase-correction voltage of 1-kc vfo is read on VTVM and can be adjusted by capacitor C1806 (accessible through bottom cover).
TEST 4 position	Phase-correction voltage of 100-cycle vfo is read on VTVM and can be adjusted by capacitor C1906 (accessible through top cover).
TEST 1 control	Adjusts phase-correction voltage of main-loop vfo.

TABLE 3-1. (Continued)

CONTROL OR INDICATOR	FUNCTION
ZERO ADJ TEST 1 switch	When depressed, allows TEST 1 control to be accurately set for zero reading on VTVM.
RF LEVEL control	Adjusts 2 to 34 mc output signal level as read on VTVM. (Red mark on VTVM is calibrated for 2.5 vrms output when synthesizer output is terminated in 50-ohm load).
2-34 MC and 100 KC front panel output jacks	Provide auxiliary r-f output and time base output for counter monitoring.
PHONE jack	Provides audio output from phase monitor for frequency comparison checks.

TABLE 3-2. RADIO FREQUENCY AMPLIFIER AM-2819/WRA-3, UNIT 1
OPERATING CONTROLS AND INDICATORS

CONTROL OR INDICATOR	FUNCTION
BAND SELECTOR	Selects one of five frequency bands: 2-4 mc, 4-8 mc, 8-16 mc, 16-23 mc, or 23-32 mc.
BAND SELECTOR RELEASE	Locks BAND SELECTOR control, when in cw (normal) position. Unlocks BAND SELECTOR control when in ccw position, and opens high voltage interlock circuit.
DRIVER TUNING (control and indicator)	Control is used to tune driver and modulator circuits. Indicator displays frequency of driver and modulator circuits.
DRIVER TUNING DIAL LOCK	Locks DRIVER TUNING control when in cw position. Unlocks DRIVER TUNING control when in ccw position.
PA TUNING (control and indicator)	Control is used to tune power amplifier circuits. Indicator displays frequency of power amplifier circuits.
PA TUNING DIAL LOCK	Locks PA TUNING control when in ccw position. Unlocks PA TUNING control when in cw position.
RF DRIVE	Varies amplitude of synthesizer signal fed to the rf amplifier circuits.
TEST KEY	Keys driver and power amplifier stages for testing. The TEST KEY is pressed down for momentary keying and up for locked keying.
TUNE OPERATE	TUNE position is used to select dummy load. OPERATE position is used to select normal rf output. High voltage interlock circuit is opened if switch is operated with HV on.
RF OUTPUT meter	Indicates relative power output of rf amplifier.
INTERLOCK DISABLED indicator	Glowes when drawer is open and interlock switch is manually disabled.

TABLE 3-3. POWER SUPPLY PP-2796/WRA-3, UNIT 2
OPERATING CONTROLS AND INDICATORS

CONTROL OR INDICATOR	FUNCTION
FILAMENT (switch)	Switches primary power to cabinet blowers, filament transformers and 144 vac 400 cycle power supply ON and OFF.
FILAMENT (indicator)	Lights when FILAMENT switch is in ON position.
LOW VOLTAGE (switch)	Switches low voltage power supplies ON and OFF.
LOW VOLTAGE (indicator)	Lights when LOW VOLTAGE switch is in the ON position.
READY (indicator)	Lights to indicate hv interlock line is closed. Extinguishes when HIGH VOLTAGE ON lamp is lit.
HIGH VOLTAGE ON pushbutton	When pressed, energizes relay K4 (if READY lamp is lit) to apply 115 vac power to +950 v and +300 v power supplies.
HIGH VOLTAGE ON (indicator)	Lights when relay K4 is energized.
HIGH VOLTAGE OFF pushbutton	Removes +28 vdc from relay K4 coil.
INTERLOCK DISABLED (indicator)	Lights when unit drawer is open and interlock switch is manually disabled.
PLATE OVERLOAD (indicator)	Lights when plate overload relay trips.
PLATE OVERLOAD RESET	Resets plate overload relay.
SCREEN OVERLOAD (indicator)	Lights when screen overload relay trips.
SCREEN OVERLOAD RESET	Resets screen overload relay.
KEYER OVERHEAT (indicator)	Indicates overheating of auxiliary equipment (when used).
PA PLATE CURRENT (meter)	Indicates power amplifier plate current, in milliamperes.
+950V blown fuse indicator (part of 2XF1)	Lights when fuse F1 in 115 vac input circuit to +950 volt dc power supply blows.
+300V blown fuse indicator (part of 2XF2)	Lights when fuse F2 in 115 vac input circuit to +300 volt dc power supply blows.
+28V blown fuse indicator (part of 2XF3)	Lights when fuse F3 in 115 vac input circuit to +28 volt dc power supply blows.
-28V blown fuse indicator (part of 2XF4)	Lights when fuse F4 in 115 vac input circuit to -28 volt dc power supply blows.
-39V blown fuse indicator (part of 2SF5)	Lights when fuse F5 in 115 vac input circuit to bias power supply blows.
FILAMENT blown fuse indicator (part of 2XF6)	Lights when fuse F6 in 115 vac input circuit to radio frequency amplifier filament transformers blows.
CONVERTER 60~ blown fuse indicator (part of 2XF7)	Lights when fuse F7 in 115 vac input circuit to 144 volt (rms) 400 cps power supply blows.
CONVERTER 400~ blown fuse indicator (part of 2XF8)	Lights when fuse F8 in 144 volt 400 cps input circuit to interconnecting unit blows.

TABLE 3-3. (Continued)

CONTROL OR INDICATOR	FUNCTION
UNIT BLOWERS blown fuse indicator (part of 2XF9)	Lights when fuse F9 in 144 volt 400 cps input circuit to unit blowers blows.
CABINET BLOWERS blown fuse indicator (part of 2XF10)	Lights when fuse F10 in 115 vac input circuit to cabinet blowers blows.

TABLE 3-4. ELECTRICAL EQUIPMENT CABINET CY-3022/WRA-3, UNIT 3
OPERATING CONTROLS AND INDICATORS

CONTROL OR INDICATOR	FUNCTION
MAIN POWER	Switches primary power to transmitter group on and off.
Main power blown fuse indicator	Lights when fuse 3F1 is blown (115 or 230 vac primary power input).
Main power blown fuse indicator (located on electrical equipment cabinet base)	Lights when fuse 3F2 is blown (115 or 230 vac primary power input).

TABLE 3-5. SUMMARY OF OPERATING PROCEDURES

OPERATING INSTRUCTIONS TRANSMITTER GROUP AN/WRA-3			
These instructions are not intended to replace the entire technical manual, but to provide ready reference to standard operating procedures. Read your technical manual.			
I STARTING THE EQUIPMENT NORMALLY			
a. To start Transmitter Group AN/WRA-3, set controls in the order listed:			
STEP	CONTROL NAME	LOCATION	POSITION
1	MAIN POWER	Electrical Equipment Cabinet	ON
2	POWER	Electrical Frequency Synthesizer	ON
NOTE			
Electrical frequency synthesizer requires one hour warmup time.			
3	BAND, MAIN TUNE, 1 KC TUNE, and 100~ TUNE	Electrical Frequency Synthesizer	To desired frequency
4	VTVM	Electrical Frequency Synthesizer	RF LEVEL
5	RF LEVEL	Electrical Frequency Synthesizer	For VTVM 2.0 volt indication
6	BAND SELECTOR, DRIVER TUNING and PA TUNING	Radio Frequency Amplifier	Desired frequency (unlock tuning controls before setting)
7	FILAMENT	Power Supply	ON
8	LOW VOLTAGE	Power Supply	ON
9	TUNE OPERATE	Radio Frequency Amplifier	TUNE
10	RF DRIVE	Radio Frequency Amplifier	0
11	HIGH VOLTAGE ON	Power Supply	Press after READY lamp lights.
12	TEST KEY	Radio Frequency Amplifier	Locking (up)
13	RF DRIVE	Radio Frequency Amplifier	To produce one-third scale reading on RF OUTPUT meter.

TABLE 3-5. (Continued)

STEP	CONTROL NAME	LOCATION	POSITION
14	DRIVER TUNING and PA TUNING	Radio Frequency Amplifier	To produce peak reading on RF OUTPUT meter.
		NOTE	
		When tuning for peak rf output, adjust RF DRIVE to keep RF OUTPUT meter needle from going off-scale.	
15	RF DRIVE	Radio Frequency Amplifier	0
16	TEST KEY	Radio Frequency Amplifier	Press and release.
17	TUNE OPERATE	Radio Frequency Amplifier	OPERATE
18	HIGH VOLTAGE ON	Power Supply	Press to restore high voltage, after either TUNE OPERATE or BAND SELECTOR control is switched.
<p>b. STARTING RADIO TRANSMITTING SET AN/WRT-2. -- To start Radio Transmitting Set AN/WRT-2 (when it is used in conjunction with the AN/WRA-3), refer to NAVSHIPS 93319(A), and set controls in the order listed:</p>			
1	EMERGENCY STOP	Power Supply	ON
2	FILAMENT POWER	Amplifier-Power Supply	ON
	POWER SELECTOR		ADJ
	EMISSION SELECTOR		CW
	PLATE POWER ON		Press
	LOCAL-REMOTE		LOCAL
3	CARRIER TEST KEY	Radio Frequency Amplifier	OFF
	P.A. CATHODE CURRENTS		TOTAL (1.5 A)
	TUNER CONTROL		1 KC STEPS
4	COUPLER ANTENNA	Radio Frequency Amplifier	2.0 to 4.0 mc: DIRECT 3.5 to 4.5 mc: B 4.0 to 5.0 mc: A 4.5 to 6.5 mc: DIRECT 5.5 to 7.5 mc: * 7.0 to 32.0 mc: DIRECT

* Set TUNER CONTROL to BYPASS position.

TABLE 3-5. (Continued)

STEP	CONTROL NAME	LOCATION	POSITION
c. STARTING RADIO SET AN/URC-32. -- To start Radio Set AN/URC-32 (when it is used in conjunction with the AN/WRA-3), refer to NAVSHIPS 93285(A), and set controls in the order listed.			
1	ON-OFF	Low-Voltage Power Supply	ON
2	FIL OFF-TUNE-OPERATE	Power Amplifier	OPERATE
3	PLATE	Power Amplifier	ON (after 30 seconds)
4	ANT-LOAD	Antenna Tuner	LOAD
II OPERATING ADJUSTMENTS			
<p>a. If the output of AN/WRA-3 is applied directly to an antenna tuner, press TEST KEY and adjust RF DRIVE for full scale reading on RF OUTPUT meter. Release TEST KEY. The transmitter group is now adjusted to transmit. For standby, press HIGH VOLTAGE OFF button.</p> <p>b. ADJUSTMENTS FOR RADIO TRANSMITTING SET AN/WRT-2. -- When the AN/WRA-3 is used with the AN/WRT-2, proceed as follows:</p>			
<p>Preliminary Procedure: Before proceeding with the operating adjustments for the AN/WRT-2, connect the AN/WRA-3 for low power output as follows: (1) extend Radio Frequency Amplifier AM-2819/WRA-3; (2) disconnect 1P5 and 1P6 from 1J5 (figure 3-5); (3) connect 1P5 and 1P6 to the attenuator circuit, connecting 1P5 to 1J10, and 1J6 to 1J11 and (4) secure the radio frequency amplifier in the cabinet.</p>			
NOTE			
The capital letters, enclosed in a circle, are front panel control markings of the AN/WRT-2.			
STEP 1	Set transmitter excitation switch (on Transmitter Transfer Control C-6562/WRA-3) to the EXT - WRA-3 position.		
STEP 2	Place LOCAL REMOTE switch at REMOTE. Turn DRIVE ADJUST control of Radio Frequency Amplifier AM-2121/WRT-2 fully ccw.		
STEP 3	Place TUNE-COUP control in TUNE position and set I.P.A. TUNING (F) and P.A. TUNING (G) to assigned frequency.		
STEP 4	Place TUNE-COUP control in COUP position, set I.P.A. FINE TUNING to 5, P.A. COUPLING (H) to 50, and DRIVE ADJUST to zero.		
STEP 5	Place OUTPUT METER switch to R-F OUTPUT and TEST AMMETER to P.A. POS. SCREEN CURRENT.		
STEP 6	Place CARRIER TEST KEY in the ON position.		
STEP 7	On AN/WRA-3, place TEST KEY in locking position (up) and set RF DRIVE control to produce a reading of one-third scale on RF OUTPUT meter.		
STEP 8	Adjust I.P.A. TUNING (F) and I.P.A. FINE TUNING controls for peak reading on TEST AMMETER. On AN/WRA-3, set RF DRIVE control to keep AN/WRT-2 TEST AMMETER needle between green scale lines.		
STEP 9	On AN/WRA-3, set RF DRIVE control to 0.		

TABLE 3-5. (Continued)

II OPERATING ADJUSTMENTS (Continued)	
STEP 10	Place POWER SELECTOR switch in the TUNE position.
STEP 11	On AN/WRA-3, adjust RF DRIVE control until a reading of 600 ma is obtained on P.A. CATHODE CURRENT meter on AN/WRT-2 (or 100 watts on R-F OUTPUT meter, whichever happens first).
STEP 12	Place TUNE-COUP control in TUNE position, and adjust P.A. TUNING (G) for peak reading on R-F OUTPUT meter. Reduce AN/WRA-3 RF DRIVE if necessary to keep output below 100 watts (on R-F OUTPUT meter, AN/WRT-2).
STEP 13	Place POWER SELECTOR switch in the 100 W position.
STEP 14	Alternately press POSITION CONTROL UP (K) and DOWN (L) buttons for peak reading on R-F OUTPUT meter.
STEP 15	Press SLOW READ SWR (M) button and alternately press POSITION CONTROL UP (K) and DOWN (L) buttons for most leftward indication on SWR INDICATOR scale. (Keep needle on scale with SWR CALIBRATE control.)
STEP 16	Adjust P.A. TUNING (G) control for peak R-F OUTPUT meter.
STEP 17	Place POWER SELECTOR switch in 500 W position.
CAUTION	
TOTAL P.A. CATHODE CURRENT MUST NOT EXCEED 825 ma for 500 watt output. TOTAL P.A. CATHODE CURRENT MUST NOT EXCEED 500 ma for no output. If these current limits are exceeded, repeat steps 7 through 14.	
STEP 18	On AN/WRA-3, adjust RF DRIVE for 500 watt reading on R-F OUTPUT meter. Alternately adjust P.A. COUPLING (H) and P.A. TUNING (G) until 500 watts is obtained with less than 15 ma on TEST AMMETER (TEST AMMETER switch in P.A. NEG SCREEN CURRENT position). When P.A. CATHODE CURRENTS switch is in TOTAL position, P.A. CATHODE CURRENTS meter should read from 700 to 750 ma.
STEP 19	Place CARRIER TEST KEY in the OFF position. On AN/WRA-3, press and release TEST KEY. The AN/WRT-2 is now adjusted to transmit the output of the AN/WRA-3. For standby, press HIGH VOLTAGE OFF button (on Power Supply PP-2796/WRA-3), and PLATE POWER OFF button (on Amplifier-Power Supply AM-2122/WRT-2).
<p>c. ADJUSTMENTS FOR RADIO SET AN/URC-32. -- To transmit the AN/WRA-3 output with the AN/URC-32, proceed as follows:</p> <p>Preliminary Procedure: Before proceeding with the operating adjustments for the AN/URC-32, connect the AN/WRA-3 for low power output. Repeat the preliminary procedure listed for the AN/WRT-2.</p>	
STEP 1	Set transmitter excitation switch (on Transmitter Transfer Control C-6562/WRA-3) to the WRA-3 position. Set EXCITER RF GAIN control of Sideband Generator 786F-1 of the AN/URC-32 to maximum ccw position.
STEP 2	Set FIL OFF-TUNE-OPERATE switch to TUNE position.
STEP 3	Place PLATE switch in KEY position.
STEP 4	On AN/WRA-3, press HIGH VOLTAGE ON switch, place TEST KEY in locking position (up) and adjust RF DRIVE to produce a reading of 200 ma on the PLATE CURRENT meter.

TABLE 3-5. (Continued)

II OPERATING ADJUSTMENTS (Continued)			
STEP 5	Adjust DRIVER TUNE for peak of PLATE CURRENT meter. (Keep PLATE CURRENT meter reading below 200 ma by adjusting RF DRIVE on AN/WRA-3.) Detune P.A. TUNE for zero power output indication on antenna tuner RF meter. Readjust DRIVER TUNE control for peak. Do not change its setting during the rest of this tuning procedure. Set PLATE switch in ON position.		
STEP 6	Set P.A. TUNE to assigned frequency according to applicable tuning chart. Place PLATE switch in KEY position, and adjust P.A. TUNE for a dip in the PLATE CURRENT meter indication. Set PLATE switch in ON position.		
STEP 7	On AN/WRA-3, turn RF DRIVE control to 0 position.		
STEP 8	Set FIL OFF-TUNE-OPERATE switch (on Power Amplifier 367A-2) to OPERATE position.		
STEP 9	Place PLATE switch in KEY position, and on the AN/WRA-3, adjust RF DRIVE for 500 watt output, as indicated on antenna tuner R. F. meter. Set PLATE switch in ON position. On control-power supply C-2691/URC, place LOCAL-REMOTE switch in the REMOTE position. On AN/WRA-3, press and release TEST KEY. Radio Set AN/URC-32 is now ready to transmit the output of the AN/WRA-3.		
III STOPPING THE EQUIPMENT			
To shut down Transmitter Group AN/WRA-3, place LOW VOLTAGE switch in the OFF position. After 3 minutes, place FILAMENT and MAIN POWER switch in OFF position. Shut down the AN/WRT-2 or AN/URC-32 by setting controls in the order listed:			
Stopping Radio Transmitting Set AN/WRT-2			
STEP	CONTROL NAME	LOCATION	POSITION
1	PLATE POWER OFF	Amplifier-Power Supply	Press
2	FILAMENT POWER	Amplifier-Power Supply	OFF
3	EMERGENCY STOP	Power Supply	OFF
Stopping Radio Set AN/URC-32			
1	PLATE	Power Amplifier	OFF
2	FIL OFF-TUNE-OPERATE	Power Amplifier	FIL OFF
3	ON-OFF	Low Voltage Power Supply	OFF

SECTION 4

TROUBLE SHOOTING

4-1. LOGICAL TROUBLE SHOOTING.

a. SYMPTOM RECOGNITION. -- This is the first step in the trouble-shooting procedure and is based on a complete knowledge and understanding of equipment operating characteristics. All equipment troubles are not the direct result of component failure. Therefore, a trouble in an equipment is not always easy to recognize since all conditions of less than peak performance are not always apparent. This type of equipment trouble is usually discovered while accomplishing preventive maintenance procedures, such as the POMSEE checks. It is important that the "not so apparent" troubles, as well as the apparent troubles, be recognized.

b. SYMPTOM ELABORATION. -- After an equipment trouble has been "recognized", all the available aids designed into the equipment should be used to further elaborate on the original trouble symptom. Use of front panel controls and other built-in indicating or testing aids should provide better identification of the original trouble symptom. Also, checking or otherwise manipulating the operating controls may eliminate the trouble.

c. LISTING PROBABLE FAULTY FUNCTION. -- The next step in logical trouble shooting is to formulate a number of "logical choices" as to the cause and likely location (functional section) of the trouble. The "logical choices" are mental decisions which are based on knowledge of the equipment operation, a full identification of the trouble symptom, and information contained in this manual. The over-all functional description and its associated block diagram should be referred to when selecting possible faulty functional sections.

d. LOCALIZING THE FAULTY FUNCTION. -- For the greatest efficiency in localizing trouble, the functional sections which have been selected by the "logical choice" method should be tested in an order that will require the least time. This requires a mental selection to determine which section to test first. The selection should be based on the validity of the "logical choice" and the difficulties in making the necessary tests. If the tests do not prove that functional section to be at fault, the next selection should be tested, and so on until the faulty functional section is located. As aids in this process the manual contains a functional description and a servicing block diagram for each functional section. Waveforms (or other pertinent indications) are included at significant check points on servicing block diagrams to aid in isolating the faulty section. Also, test data (such as information on control settings, critical adjustments, and

required test equipment) are supplied to augment the functional description and servicing block diagram for each functional section.

e. LOCALIZING TROUBLE TO THE CIRCUIT. -- After the faulty functional section has been isolated, it is often necessary to make additional "logical choices" as to which group of circuits or circuit (within the functional section) is at fault. Servicing block diagrams for each functional section and individual functional circuit groups (when required) provide the signal flow and test location information needed to bracket and then isolate the faulty circuit. Functional descriptions, simplified schematics, and pertinent test data for individual circuits or groups of circuits comprising the functional section are all placed together in one area of the manual. Insofar as is practicable, this information is contained on facing pages. Information which is too lengthy in nature to be included in this arrangement is readily referenced from the test data portion of the trouble-shooting information.

f. FAILURE ANALYSIS. -- After the trouble (faulty component, misalignment, etc.) has been located (but prior to performing corrective action), the procedures followed up to this point should be reviewed to determine exactly why the fault affected the equipment in the manner it did. This review is usually necessary to make certain that the fault discovered is actually the cause of the malfunction, and not just the result of the malfunction.

4-2. OVER-ALL FUNCTIONAL DESCRIPTION.

Transmitter Group AN/WRA-3 is a low power, high frequency, continuous wave (cw) transmitter, primarily designed for use as an exciter for larger transmitting equipment. However, the transmitter group can be used separately for direct transmission. The frequency range of the transmitter group is 2 to 32 mc. The power output is variable to 1.5 watts, when used as an exciter, and 15 watts when used as an independent transmitter. For specific data pertaining to the over-all equipment performance characteristics, refer to Performance Standards Sheet NAVSHIPS 0967-031-9020.

The transmitter group is comprised of seven separate units and an electronic modification kit, namely: Electrical Frequency Synthesizer O-1115/URC(GFM), Interconnecting Unit MX-3645/WRA-3, Radio Frequency Amplifier AM-2819/WRA-3, Power Supply PP-2796/WRA-3, Electrical Equipment Cabinet CY-3022/WRA-3, Resilient Mount MT-2661/WRA-3, Relay Assembly RE-754/WRT-4, and Modification Kit MK-846/WRA-3. Note that

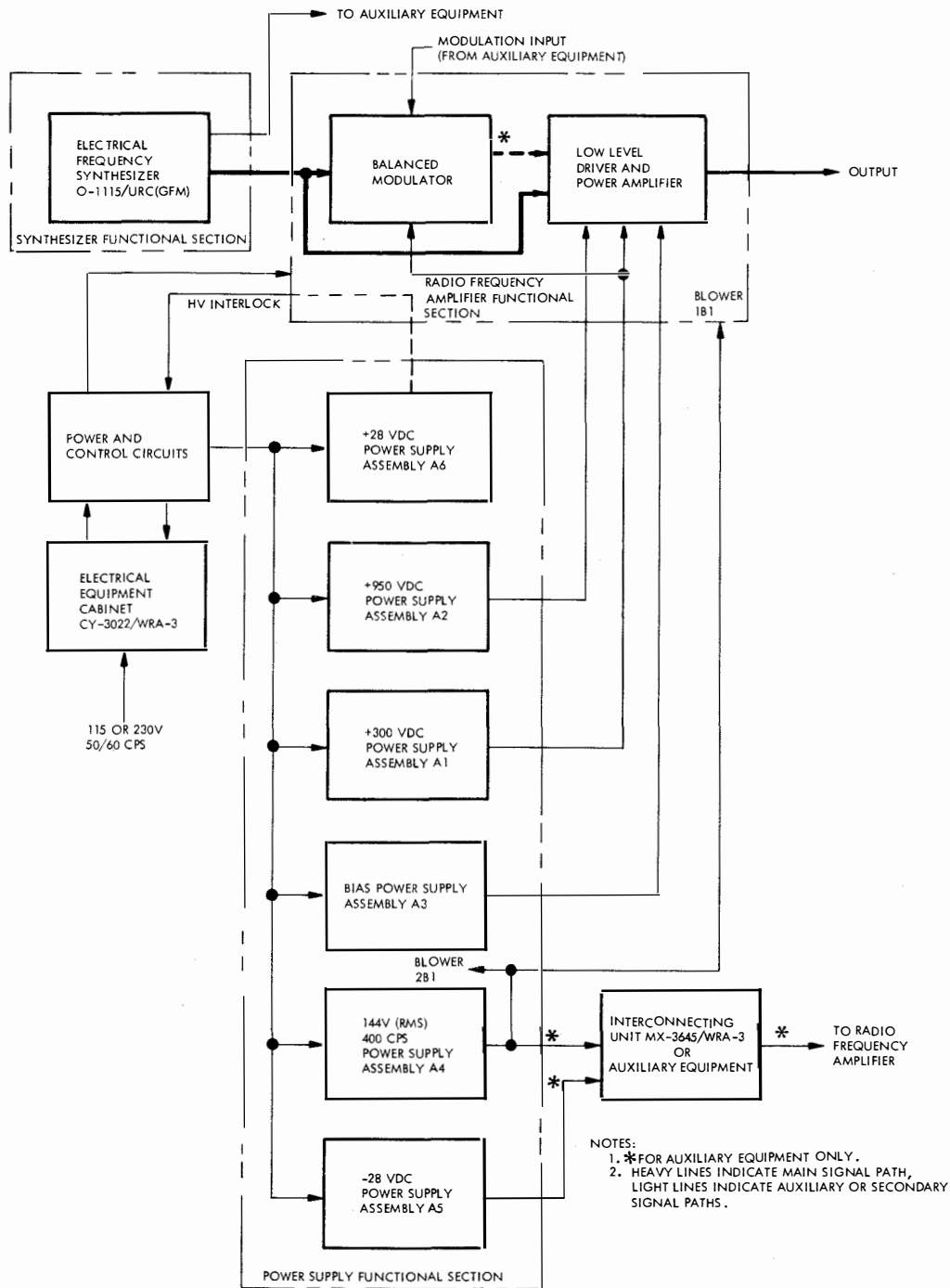

657-18

Figure 4-1. Transmitter Group AN/WRA-3, Over-All Functional Block Diagram

the relay assembly and the modification kit are used only when the transmitter group is used as an exciter for larger transmitting equipment. Refer to paragraphs 1-3h and 1-3i for details. Six of the seven units perform electrical functions while the seventh, the resilient mount, performs a mechanical function. Five of the six electrical units are part of the transmitter group proper, with the sixth unit, the relay assembly, being a separate unit. Also, of the five remaining units, the interconnecting unit and the electrical equipment cabinet provide, in essence, a terminating point for interconnecting cables. Consequently the remaining three units (synthesizer, radio frequency amplifier and power supply) are the three functional sections of the transmitter group, see figure 4-1.

The electrical frequency synthesizer generates an rf signal that is applied either to the balanced modulator of the radio frequency amplifier, when auxiliary equipment is used, or directly to the driver amplifier, when auxiliary equipment is not used. Refer to NAVSHIPS 0967-047-7010 for auxiliary equipment details. In addition, the synthesizer furnishes a reference frequency to the auxiliary equipment when used. In the driver amplifier stage the rf signal is amplified to a level sufficient to drive the power amplifier. The output of the power amplifier is either coupled to an antenna for direct transmission, or coupled to the power amplifier of a larger transmitter, amplified to a higher power level and then applied to the antenna for transmission. When the interconnecting unit is replaced by auxiliary equipment, the frequency of operation is established by the combination of the electrical frequency synthesizer signal and the modulation signal from the auxiliary equipment.

The power supply provides plate, screen, and bias voltages for the radio frequency amplifier, +28 vdc for a high voltage interlock and control circuit, 144V (rms) 400 cps for unit blowers and auxiliary equipment, and -28 vdc for auxiliary equipment.

Refer to paragraphs 4-3i(2) through 3-4i(5) for a description of the interconnecting unit, electrical equipment cabinet, resilient mount, and relay assembly.

4-3. FUNCTIONAL SECTION DESCRIPTION.

a. OVER-ALL FUNCTIONAL SECTION DESCRIPTION. -- A detailed description of each of the three functional sections (figure 4-1) is given in paragraphs 4-3c, 4-3e, and 4-3g, with the emphasis of this paragraph and paragraph 4-3b being placed on over-all equipment trouble shooting.

Prior to trouble shooting the transmitter group, on a functional section basis, it is first necessary to isolate the malfunction to one of the three functional sections. This isolation is best accomplished by an over-all equipment trouble shooting

procedure: that is, a comprehension of the data contained in the first three sections of this technical manual, a visual inspection both externally and internally of the transmitter group and its various units, and following the procedure outlined in this paragraph and paragraph 4-3b.

To efficiently troubleshoot the transmitter group it is essential that the technician be completely familiar with the operation of the equipment. If this familiarity does not exist it is recommended that Sections 1, 2, and 3 of this manual be read. The information contained in Section 1 will provide general equipment information; Section 2 will provide information as to installation, power requirements and special adjustments, etc.; and Section 3 will provide operating knowledge as well as normal indicator readings, fuse locations, proper control settings, etc.

Visual inspection is helpful in locating obvious troubles and in many cases will actually isolate the defective functional section, stage and/or component. The visual inspection should include: inspection for broken or burnt resistors, broken standoff terminals, cold solder joints, loose or broken wires, accidental shorting of component leads with chassis or other components, broken or improperly operating drawer interlock switches, improper mating of connectors, etc. Inspect the primary power source. If the electrical frequency synthesizer is connected for 400 cps primary power (paragraph 2-8), include inspection of the 115 vac, 400 cps power source.

Prior to withdrawing the various units from the electrical equipment cabinet, for visual inspection, it is first necessary to deenergize the equipment (paragraph 3-2b(4)(a)), then proceed as follows.

1. Electrical Frequency Synthesizer O-1115/URC, Unit 5: Disengage captive screw located in each handle assembly and withdraw unit fully to engage slide locks; pull outward on tilt lock handles located at front, left and right sides of unit, near start of slide mechanism; tilt unit to desired lock position (45 or 90 degrees up or down). (To slide unit into cabinet, return unit to normal position and press downward on slide-lock release levers located on top of slide mechanisms.)

2. Interconnecting Unit MX-3645/WRA-3, Unit 4: Disengage two captive screws at each side of panel and withdraw unit fully to engage slide locks; pull outward on tilt lock handles located on front, left and right sides of unit near start of slide mechanism; tilt unit to desired lock position (45 or 90 degrees up or down). (To slide unit into cabinet, return unit to normal position and press downward on slide-lock release blocks located at top rear of each slide mechanism.)

3. Radio Frequency Amplifier AM-2819/WRA-3, Unit 1: Disengage two captive screws at each side

TABLE 4-1. TRANSMITTER GROUP AN/WRA-3 PRELIMINARY CONTROL SETTINGS FOR TROUBLE SHOOTING

CONTROL	LOCATION	SETTING
MAIN POWER (3S1)	Electrical equipment cabinet panel	ON
POWER (5S1)	Synthesizer panel	ON
FILAMENT (2S7)	Power supply panel	ON
LOW VOLTAGE (2S6)	Power supply panel	ON
HIGH VOLTAGE (2S4)	Power supply panel	ON
RF DRIVE (1R33)	Radio frequency amplifier panel	0
TEST KEY (1S4)	Radio frequency amplifier panel	OFF (center)
TUNE/OPERATE (1S3)	Radio Frequency amplifier panel	TUNE

of panel and withdraw unit fully to engage slide locks; pull outward on tilt lock handles located on front, left and right sides of unit near start of slide mechanism; tilt unit to desired lock position (45 or 90 degrees up or down); remove covers as required for desired degree of access. To slide unit into cabinet, return unit to normal position and press SLIDE RELEASE button at each side of panel.

4. Power Supply PP-2796/WRA-3, Unit 2: Disengage two captive screws at each side of panel and withdraw unit fully to engage slide locks; pull outward on tilt lock handles located on front, left and right sides of unit near start of slide mechanism; tilt unit to desired lock position (45 or 90 degrees up only); remove covers as required for desired degree of access. To slide unit into cabinet, return unit to normal position and press SLIDE RELEASE button at each side of panel.

b. FUNCTIONAL SECTION ISOLATION PROCEDURE. -- If the visual inspection procedure, outlined in paragraph 4-3a, failed to isolate the trouble, it then becomes necessary to determine, electrically, which one (or more) of the three functional sections is malfunctioning. This is accomplished by performing steps 1 through 5 of the following procedure. Note that the transmitter group is to be "set up" for type A1 emission (paragraph 3-2b(1)(b), steps 1 through 3) and direct transmission at 15 watts (paragraph 3-2b(1)(b)1, steps 1 and 2). Tuning controls are to be set for 2 mc, unless the trouble has been localized to a particular band(s). (Refer to table 3-5, part 1, steps 1 through 6.) Also, place the TUNE/OPERATE switch 1S2 in the TUNE position and the RF DRIVE control to 0. At this stage of trouble shooting it is assumed that all fuses and indicators

have been checked for malfunction and that operation of the equipment has been checked against the procedure listed in Section 3.

WARNING

DANGEROUSLY HIGH VOLTAGE (APPROXIMATELY 1000 VOLTS) IS PRESENT IN THE RADIO FREQUENCY AMPLIFIER AND POWER SUPPLY UNITS, AND MAY CAUSE SERIOUS INJURY OR DEATH IF PERMITTED TO CONTACT THE BODY. PRIOR TO ATTEMPTING ANY VOLTAGE MEASUREMENTS, PRESS POWER SUPPLY HIGH VOLTAGE OFF SWITCH 2S5, AND, USING AN APPROPRIATELY INSULATED JUMPER, SHORT 2S2J1 AND J2, FIGURES 5-5 AND 5-17, BEFORE CONNECTING METER LEADS. DO NOT RELY ON DRAWER INTERLOCK SWITCHES TO DEENERGIZE HV CIRCUITS.

Step 1. Place FILAMENT switch 2S7 (power supply) to ON position. FILAMENT indicator 2DS7 should light. The cabinet, power supply and radio frequency amplifier blowers should operate (audibly detected) and radio frequency amplifier tuning dial lamps should illuminate. If indications are normal, proceed to step 2. If FILAMENT indicator fails to light, check 2R2, figure 5-3 (sheet 3). If cabinet blowers fail to operate, check blowers 3B1 and 3B2, and primary power distribution to 3TB2-1, -4, figures 5-11 and 5-13. If power supply and radio frequency blowers fail to operate, check blowers 1B1 and 2B1,

- figures 5-10 (sheet 2) and 5-3 (sheet 2). If no indications are obtained, check primary power source at 3TB1-6, -7, line filter 3Z1, and autotransformer 3T1, figures 5-11 and 5-13.
- Step 2. Place LOW VOLTAGE switch 2S6 (power supply) to ON position. LOW VOLTAGE indicator 2DS6 should light and READY indicator 2DS4 should light within 30 seconds. If indications are normal, proceed to step 3. If no indication is obtained, check +28 vdc power supply (paragraph 4-3f(4), step 20). If LOW VOLTAGE indicator fails to light, check 2R1 (figure 5-3, sheet 3). If READY indicator 2DS4 fails to light, observe PLATE OVERLOAD and SCREEN OVERLOAD indicators 2DS1 and 2DS2 (figure 5-3, sheet 1); if either indicator is lighted, press PLATE OVERLOAD RESET 2S3 or SCREEN OVERLOAD RESET 2S1 to reset interlock line. Check drawer interlocks 2S2 and 1S5 (figures 2-4 and 2-5). Check band selector and tune-operate interlock switches 1S7 and 1S8 (figure 5-2). Check hv time delay switch 1S2 and output of filament transformer 1T4, figure 5-10 (sheet 2). Check overload relays 2K2 and 2K3, figure 5-3 (sheet 3).
- Step 3. Press HIGH VOLTAGE ON switch 2S4 (power supply). HIGH VOLTAGE ON indicator 2DS5 should light and READY indicator 2DS4 should cease to light. If indications are normal, proceed to step 4. If indications are abnormal, check hv operate relay 2K4, figure 5-3 (sheet 3). If PLATE OVERLOAD indicator lights, deenergize equipment and check for overload in power amplifier circuit; refer to figure 5-16 for resistance measurements.
- Step 4. Place TEST KEY 1S4 to up position; adjust RF DRIVE 1R33 for full scale indication on RF OUTPUT meter 1M1 with DRIVER TUNING and PA TUNING controls adjusted for peak indication. Refer to table 4-2 for normal indication at nearest frequency to which equipment is tuned. If PLATE OVERLOAD indicator lights repeatedly, check overload relay adjustment, paragraph 5-3d(1)(a), bias supply adjustment, paragraph 5-3d(1)(b), and power amplifier circuit. If SCREEN OVERLOAD indicator lights repeatedly, refer to figure 5-16 for resistance measurements. If unable to adjust RF DRIVE control for proper indication on RF OUTPUT meter, read PA PLATE CURRENT meter. PA PLATE CURRENT should be approximately 190 to 220 ma. If normal indication is obtained on PA PLATE CURRENT meter, check synthesizer (paragraph 4-3d), power supply (paragraph 4-3f), and radio frequency amplifier (paragraph 4-3h). If PA PLATE CURRENT meter indication is not normal, check the power supply (paragraph 4-3f) and radio frequency amplifier (paragraph 4-3h).
- Step 5. Check to see if malfunction is present on all bands. If malfunction is not present on all bands, check synthesizer (paragraph 4-3d) and radio frequency amplifier (paragraph 4-3h).
- Step 6. If at this stage of over-all equipment trouble shooting, the malfunction has not been isolated to a particular functional section, or stage, refer to paragraphs 4-3c through 4-3j, respectively, and perform the procedures as outlined.
- c. SYNTHESIZER FUNCTIONAL SECTION DESCRIPTION. -- Electrical Frequency Synthesizer O-1115/URC is a Government Furnished item. Complete information pertaining to a functional section description of this equipment is contained in NAVSHIPS 94829, paragraphs 4-3 through 4-10.
- For application with the transmitter group it will suffice to note that the synthesizer is basically a precision frequency generator that produces 690,000 discrete frequencies ranging from 2 to 34 mc. Auxiliary output signals of 1 mc and 100 kc are also provided. Radio frequency signals, from 2 to 32 mc, and a 1 mc reference signal (used only with auxiliary equipment) are applied, from the synthesizer, to Radio Frequency Amplifier AM-2819/WRA-3 and Interconnecting Unit MX-3645/WRA-3 respectively of the transmitter group. Note that the transmitter group is designed to use a synthesizer requiring 115V 60 cycle single phase input power. Refer to paragraph 2-8 when a synthesizer requiring 115V 400 cycle single phase input power is used.
- d. SYNTHESIZER FUNCTIONAL SECTION TEST DATA. -- Information which will aid in determining whether a malfunction is present in the synthesizer is as follows:
- (1) CONTROL SETTINGS. -- As indicated in steps 1 and 2 of the test procedure.
 - (2) TEST EQUIPMENT AND SPECIAL TOOLS. -- Multimeter AN/USM-116 or Hewlett-Packard 410B. There are no requirements for special tools.
 - (3) PERFORMANCE INDICATORS. -- As indicated in step 2 of the test procedure.
 - (4) TEST POINTS. -- Test points are used to facilitate trouble shooting. The test points used in isolating a malfunction to a functional section are

identified by a capital letter enclosed within a circle A, B, etc. In the text test points are identified by a circle followed by the applicable letter oA, oB, etc. See figure 4-3 for the circuit location of test points and figure 5-10 (sheet 2) for the physical location of test points.

(5) TEST. -- Perform the following test to determine whether the synthesizer functional section is faulty.

- Step 1. Place POWER switch in ON position and VTVM switch in RF LEVEL position (synthesizer front panel).
- Step 2. Adjust RF LEVEL control for 2 volt indication on VTVM meter.
- Step 3. If meter indication cannot be reduced to 2 volts, check cabling interconnecting synthesizer and Radio Frequency Amplifier AM-2819/WRA-3, figure 2-10. If still unable to obtain 2 volts, refer to NAVSHIPS 94829, Section 4, for additional troubleshooting procedures.
- Step 4. If 2 volts is indicated, withdraw Radio Frequency Amplifier AM-2819/WRA-3 from cabinet (paragraph 4-3a(3)).
- Step 5. Disconnect 1P2 from 1J2 (figure 5-10 (sheet 1)). Using the AN/USM-116, connect AC probe to 1J2, test point oA, figures 4-3 and 5-10 (sheet 1), and ground probe clip to chassis.
- Step 6. The multimeter indication should be in excess of 2 vrms. (The voltage is in excess of 2 volts, since disconnecting 1P2 from 1J2 removes the 50 ohm termination from the synthesizer.)
- Step 7. If reading is not present at 1J2, check cable and connectors interconnecting synthesizer to the radio frequency amplifier.
- Step 8. If cables check OK, refer to NAVSHIPS 94829 for additional trouble-shooting procedures.
- Step 9. If reading is present at 1J2, reconnect to 1P2 and proceed as follows.

e. POWER SUPPLY FUNCTIONAL SECTION DESCRIPTION. (See figure 4-1, 4-2 and 5-17.) -- Power Supply PP-2796/WRA-3 provides dc power for the operation of Radio Frequency Amplifier AM-2819/WRA-3. The power supply also supplies ac (400 cps) and dc power to auxiliary equipment when installed. Portions of control circuits and a high voltage interlock circuit are also included in the power supply. Refer to paragraph 4-3i(1) for control and power circuit details. The power supply unit is comprised of six separate power

supply assemblies. These assemblies are discussed as follows:

(1) +300 VOLT DC POWER SUPPLY 2A1. -- Power amplifier screen voltage and the B+ voltages for the balanced modulator and driver stages are obtained from the +300 volt supply. The circuit supplies +300 vdc at 80 ma maximum, and has an input transformer, a conventional full-wave silicon diode bridge rectifier with filtering and Zener diode regulation.

(2) +950 VOLT DC POWER SUPPLY 2A2. -- The plate voltage for the power amplifier is obtained from the unregulated +950 volt supply, consisting of an input transformer, a full-wave bridge rectifier, and a filtering network. The maximum current normally supplied is 200 ma.

(3) BIAS POWER SUPPLY 2A3. -- Grid bias voltage (-24 to -39 vdc) for the power amplifier is obtained from the bias power supply. The supply consists of a transformer, T1, a full-wave bridge rectifier, CR1 through CR4, filter network (C1, L1, and R3), and Zener diode regulator CR5. The output voltage is adjustable from -24 to -39 vdc by potentiometer R1. Normally, the bias circuits do not draw current from the bias power supply.

(4) 144 VOLT (RMS) 400 CYCLE POWER SUPPLY 2A4. -- The 144 volt (rms) power supply converts the primary power (115 volt 50 to 60 cps) input to 144 volt (rms) 400 cps. The output of 2A4 provides power for blower motors 1B1 and 2B1, and is available for auxiliary equipment power. The output of 2A4 is a quasi square wave. Assembly 2A4 consists of a regulated dc power supply, a 400 cycle oscillator, and a power amplifier. The 400 cps oscillator consists of Q3 and Q4, operating in push-pull, with R5 and R6 supplying base bias. Oscillator voltage is regulated by CR5, Q1 and Q2. Positive voltage to the oscillator emitters is derived directly from the full-wave bridge rectifier CR1-CR4, but oscillator collector voltage is obtained from the emitter of Q2. Transistor Q2 is biased by a fixed voltage reference from Zener diode CR 5 through reference amplifier Q1. The 400-cycle oscillator output is applied to the power amplifier through transformer T2. The output frequency is set to 400 cps by adjustment of R2.

The power amplifier consists of transistors Q5 through Q8 operating in push-pull parallel. Collector voltage to the 400 cycle power amplifier is unregulated. The output frequency of the supply is adjusted by varying oscillator voltage with R2 to obtain 400 cps with a load current of 1.3 amp.

(5) 28 VOLT POWER SUPPLIES 2A5 AND 2A6. -- Assemblies 2A5 and 2A6 are two nearly identical 28-volt supplies connected to obtain opposite output polarities (with respect to ground). The circuit for either 28-volt supply contains an input transformer T1 with two secondary windings. One

winding is connected to a half-wave silicon rectifier CR1, which provides voltage for zener diode CR4. Another winding is connected to a full-wave rectifier (CR2 and CR3), which is the power rectifier. A series regulator (Q2 and Q3) acts as a variable resistance to regulate output voltage. Zener diode CR4 establishes a fixed reference voltage (across R2 and R3) which holds the base of Q1 at a constant negative voltage with respect to the positive output line. The emitter voltage of Q1 is held constant with respect to the positive output line, because any change in Q1 emitter voltage causes a change in base current and causes Q1 to change conduction to bring the voltage back to the initial value. The emitter of Q1 is connected to the bases of, and is the voltage reference for, the series regulator transistors Q2 and Q3. The emitters of Q2 and Q3 are kept at a constant negative voltage with respect to the positive output line in the same way as the emitter of Q1. The negative output of the supply is taken from the emitters of Q2 and Q3. The output voltage is adjusted (by setting R1) for 28 vdc. The maximum current supplied by the positive 28-volt supply 2A6 is 2 amperes. In 2A6, regulators Q2 and Q3 are connected in parallel. Assembly 2A5 has two -28 volt outputs, one regulated by Q2, the other by Q3. One output of 2A5 supplies 1.4 amperes maximum, and the other output supplies 0.7 ampere maximum.

f. POWER SUPPLY FUNCTIONAL SECTION TEST DATA. -- Information which will aid in determining whether a malfunction is present in the power supply is as follows:

(1) CONTROL SETTINGS. -- Refer to table 4-1 for proper control settings.

(2) TEST EQUIPMENT AND SPECIAL TOOLS. -- Use Multimeter AN/PSM-4 throughout. There are no requirements for special tools.

(3) TEST POINTS. -- Test points used in isolating the trouble in the power supply functional section are identified by a capital letter enclosed within a circle (A). In the test the test point is identified by a circle followed by the applicable letter, oA, oB, etc. See figure 4-2 for circuit location of test points and figures 5-3, 5-5, 5-8, and 5-9 for physical location of test points.

(4) TEST. -- Perform the following test to determine whether the power supply functional section is faulty. Once the fault has been isolated to a particular stage, refer to figure 5-17 for additional voltage and resistance data.

WARNING

DANGEROUSLY HIGH VOLTAGE (APPROXIMATELY 1000 VOLTS) IS PRESENT IN THE POWER SUPPLY AND MAY CAUSE SERIOUS INJURY OR DEATH IF PERMITTED TO CONTACT THE BODY. USE EXTREME CAUTION WHEN TROUBLE

SHOOTING WITH DRAWER INTERLOCKS DISABLED. PRIOR TO ATTEMPTING ANY VOLTAGE MEASUREMENTS, PRESS HIGH VOLTAGE OFF SWITCH 2S5, AND CONNECT METER LEADS. DO NOT PRESS HIGH VOLTAGE ON SWITCH 2S4 UNTIL PERSONNEL ARE CLEAR OF EXPOSED EQUIPMENT. DO NOT RELY ON DRAWER INTERLOCK SWITCHES TO DEENERGIZE HV CIRCUITS.

- Step 1. Place FILAMENT switch 2S7 to OFF position.
- Step 2. Place LOW VOLTAGE switch 2S6 to OFF position.
- Step 3. Withdraw power supply drawer from cabinet (paragraph 4-3a(4)).
- Step 4. Defeat drawer interlock switch 2S2, figure 2-4.
- Step 5. Connect multimeter between 2TB1-7 and -9, test point oA, figure 4-2 and 5-3 (sheet 3).
- Step 6. Place FILAMENT switch 2S7 to ON position. A normal indication of 124 to 164 volts should register on multimeter. If indication is normal, proceed to step 10. If indication is abnormal, proceed to next step.
- Step 7. Connect multimeter between 2A2T3-1 and -3, test point oB, figures 4-2 and 5-3 (sheet 2). A normal indication of 42 vac (approximately) should register on multimeter. If indication is normal, check transformer 2A4T3 secondary winding (figure 5-7 (sheet 1)) and external circuits (blowers 1B1, 2B1, and associated phase shifting capacitors 1C95, 2C4, figures 5-10 (sheet 2) and 5-3 (sheet 2)). If indication is abnormal proceed to next step.
- Step 8. Connect multimeter between 2A4T2-1 and -3, test point oC, figures 4-2 and 5-3 (sheet 2). A normal indication of 50 vac (approximately) should register on multimeter. If indication is normal, check amplifiers 2A4Q5 through Q8, 2A4T3 primary, and 2A4R1 through R10, figure 5-7 (sheet 1). If indication is abnormal proceed to next step.
- Step 9. Connect multimeter between 2A4T3-2 and chassis ground, test point oD, figures 4-2 and 5-3 (sheet 2). A normal indication of +28 vdc (approximately) should register on multimeter. If indication is normal, check voltage regulator 2A4Q1, Q2 and associated components;

400 cps oscillator circuit 2A4Q3, Q4, 2A4T2, and associated components, figure 5-7 (sheet 1). If indication is abnormal check bridge rectifiers 2A4CR1 through CR4, figure 5-7 (sheet 2); check primary power input to 2A4T1, figure 5-7 (sheet 1).

- Step 10. Connect multimeter between 2TB1-5 and ground, test point oE, figures 4-2 and 5-3 (sheet 3).
- Step 11. Place LOW VOLTAGE switch 2S6 to ON position. A normal indication of -24 to -41 vdc should register on multimeter. If indication is normal proceed to step 14. If indication is abnormal check bias adjustment 2A3R1 (refer to paragraph 5-3d(1)(b)); if unable to obtain proper output, proceed to next step.
- Step 12. Connect multimeter between 2A3J2 and ground, test point oF, figures 4-2 and 5-3 (sheet 2). A normal indication of -39 to -44 vdc should register on multimeter. If the indication is normal, check filter 2A3L1, 2A3R3, and zener diode 2A3CR5, figure 5-6. If indication is abnormal proceed to next step.
- Step 13. Connect multimeter between 2A3T1-3 and -4, test point oG, figures 4-2 and 5-3 (sheet 2). A normal indication of 38 vac (approximately) should register on multimeter. If indication is normal, check bridge network 2A3CR1 through CR4 and filter capacitor 2A3C1, figure 5-6. If indication is abnormal, check transformer 2A3T1 and primary power input to 2A3T1 for open or shorted coil windings.
- Step 14. Connect multimeter between 2TB2-12 and ground, test point oH, figures 4-2 and 5-3 (sheet 3). A normal indication of -27.5 to -28.5 vdc should register on multimeter. If indication is normal proceed to step 15. If indication is abnormal also proceed to step 15.
- Step 15. Connect multimeter between 2TB2-11 and ground, test point oI, figures 4-2 and 5-3 (sheet 3). A normal indication of -27.5 to -28.5 vdc should register on multimeter. If indication is normal proceed to step 20. If only one of the readings of step 14 and 15 is abnormal, check the associated regulator circuitry, figure 5-17. If both of the readings of steps 14 and 15 are abnormal, check -28 V adjustment 2A5R2; refer to paragraph 5-3d(1)(d).
- Step 16. Connect multimeter between 2A5J2 and ground, test point oJ, figure 4-2 and

5-8. A normal indication of -28 vdc (approximately) should register on multimeter. If indication is normal, proceed to step 18; if indication is abnormal, proceed to next step.

- Step 17. Place MAIN POWER switch 3S1 and LOW VOLTAGE switch 2S6 to OFF positions, and partially remove assembly 2A5; refer to paragraph 5-4c. Connect multimeter between 2A5T1-3, -4, test point oK, figures 4-2 and 5-8. Place MAIN POWER switch and LOW VOLTAGE switch 2S6 to ON position; a normal indication of 92 vac (approximately) should register on multimeter. If indication is normal, check regulator bias circuit, 2A5CR1, 2A5R1 through R3, zener diode 2A5CR4, and 2A5C1, C4. If indication is abnormal, check primary power input to 2A5T1.
- Step 18. Connect multimeter between 2A5J1 and ground, test point oL, figures 4-4 and 5-8. A normal indication of -40 vdc (approximately) should register on multimeter. If indication is normal, check voltage regulator 2A5Q1, Q2, Q3, and associated components. If indication is abnormal, proceed to next step.
- Step 19. Connect multimeter between 2A5T1-5 and -7, test point oM, figures 4-2 and 5-8. A normal indication of 64 vac (approximately) should register on multimeter. If indication is normal, check rectifiers 2A5CR2, CR3 and capacitors 2A5C2 and C3.
- Step 20. Connect multimeter between 2TB2-15 and ground, test point oN, figures 4-2 and 5-3 (sheet 3). A normal indication of +27.5 to +28.5 vdc should register on multimeter. If indication is normal, proceed to step 25. If indication is abnormal, check +28 volt adjustment 2A6S2, refer to paragraph 5-3d(1)(c). If indication is still abnormal, proceed to next step.
- Step 21. Connect multimeter to 2A6J2 and 2TB2-15, test point oO, figures 4-2, 5-9 and 5-3 (sheet 3). A normal indication of -28 vdc (approximately) should register on multimeter. If indication is normal, proceed to step 23. If indication is abnormal, proceed to next step.
- Step 22. Place MAIN POWER switch 3S1 and LOW VOLTAGE switch 2S6 to OFF positions, and partially remove assembly 2A6; refer to paragraph 5-4c. Connect multimeter between 2A6T1-3, -4, test

- point oK, figure 4-2 and 5-9. Place MAIN POWER switch and LOW VOLTAGE switch to ON position. A normal indication of 92 vac (approximately) should register on multimeter. If indication is normal, check regulator bias circuit, 2A6CR1, 2A6R1 through R3, zener diode 2A6CR4 and 2A6C1, C4. If indication is abnormal, check primary power input to 2A6T1.
- Step 23. Connect multimeter between 2A6J1 and 2TB2-15, test point oP, figure 4-2, 5-9 and 5-3 (sheet 3). A normal indication of -40 vdc (approximately) should register on multimeter. If indication is normal, check voltage regulator 2A6Q1, Q2, Q3 and associated components. If indication is abnormal, proceed to next step.
- Step 24. Connect multimeter between 2A6T1-5 and -7, test point oM, figures 4-2 and 5-9. A normal indication of 64 vac (approximately) should register on multimeter. If indication is normal, check rectifier 2A6CR2, CR3, and capacitors 2A6C2 and C3.
- Step 25. Connect multimeter between 2TB1-3 and ground, test point oQ, figures 4-2 and 5-3 (sheet 3). Press HIGH VOLTAGE ON switch 2S4; place TEST KEY 1S4 (radio frequency amplifier panel) to up position. A normal indication of 285 vdc to 315 vdc should register on multimeter. If indication is normal, proceed to step 30. If indication is abnormal, proceed to next step.
- Step 26. Connect multimeter between 2A1J2 and ground, test point oR, figures 4-2 and 5-3 (sheet 2). A normal indication of 320 vdc (approximately) should register on multimeter. If indication is normal, check 2A1L1B, figure 5-4. If indication is abnormal, proceed to next step.
- Step 27. Connect multimeter between 2A2J1 and ground, test point oS, figures 4-2 and 5-3 (sheet 2). A normal indication of 335 vdc (approximately) should register on multimeter. If indication is normal, check 2A2C1A, figure 5-4. If indication is abnormal, proceed to next step.
- Step 28. Connect multimeter between 2A1TB1-4 and ground (junction of 2A1CR1 and CR3), test point oT, figure 4-2 and 5-3 (sheet 2). A normal indication of 370 vdc (approximately) should register on multimeter. If indication is normal, check zener diodes 2A1CR5 through CR7, 2A1R1 through R4, and 2A1C1 through C3, figure 5-4. If indication is abnormal, proceed to next step.
- Step 29. Connect multimeter between 2A1T1-3 and -4, test point oU, figures 4-2 and 5-3 (sheet 2). A normal indication of 330 vac (approximately) should register on multimeter. If indication is normal, check rectifier bridge, 2A1CR1 through CR4, figure 5-4. If indication is abnormal, check input power to transformer 2A1T1.
- Step 30. Press HIGH VOLTAGE OFF switch 2S5. Connect multimeter between 2A2J1 and ground test point oV, figures 4-2 and 5-3 (sheet 2). Press HIGH VOLTAGE ON switch 2S4. A normal indication of 930 vdc to 970 vdc should register on multimeter. If for some reason normal load current is not being drawn, voltage may rise as high as 1050 vdc. If indication is normal, proceed to next step. If indication is abnormal, check filter network 2A2C13 through C16, 2A2L1, and resistors 2A2R13, R14, figure 5-5. Place MAIN POWER switch 3S1 to OFF position, and check rectifier bridge 2A2CR1 through CR12 and associated diode resistor-capacitor protection networks.
- Step 31. Connect multimeter across 2A2T1-3, -4, test point oW, figures 4-2, 5-5 and 5-17. A normal indication of 757 vac (approximately) should register on multimeter. If indication is abnormal, check 2A2T1. Place MAIN POWER switch in ON position. When READY lamp lights, press HIGH VOLTAGE ON switch 2S4 and check primary power to 2A2T1 at 2TB6-14 and -15, figure 5-3 (sheet 3).
- g. RADIO FREQUENCY AMPLIFIER FUNCTIONAL SECTION DESCRIPTION. (See figures 4-1, 4-3, 4-4, and 5-16.) -- Radio Frequency Amplifier AM-2819/WRA-3 consists of four stages: balanced modulator V1 and V2, first driver amplifier V3, second driver amplifier V4, and power amplifier V5. When the transmitter group is operating with auxiliary equipment the attenuated rf signal from the synthesizer and a modulation signal from the auxiliary equipment are routed to the balanced modulator. When auxiliary equipment is not used, the rf input signal from the synthesizer, is routed through the attenuator circuits directly to the first driver amplifier V3.
- (1) BALANCED MODULATOR. -- Balanced modulator tubes V1 and V2 operate as a class A amplifier mixer. When auxiliary equipment is used, the input from the synthesizer is applied to the control grid of each tube, and the modulation input from auxiliary equipment is applied to the suppressor grids. Each of these inputs is applied, using the same method used for the input to a push-pull amplifier. Each signal input of one tube is 180° out of phase with the corresponding input to

the other tube. The plates of V1 and V2 are connected together to combine (sum) the outputs of V1 and V2.

The rf signal from the synthesizer is cancelled by V1 and V2. If there is no modulation input, the amplified signals of equal voltage and opposite phase are cancelled in the common plate circuit, and the balanced modulator has no output. Modulation applied to the suppressor grids changes the balanced condition of the circuit, unbalancing the modulator alternately in one direction and then the other. When both input signals are fed to the balanced modulator, modulation occurs as a result of the combined effect of the input signals on the plate currents of V1 and V2. The two original input signals are essentially cancelled in the common plate (output) circuit, leaving only the sum and difference frequencies.

The output of the modulator consists of sidebands (products of the heterodyning or mixing of the two inputs). The output is coupled by C9 to the tuned circuit selected by the BAND SELECTOR control. This tuned circuit, and the tuned circuits of the following amplifier stages, are tuned to the center of the desired sideband.

The balance of the modulator is initially adjusted with R11 and C2. Potentiometer R11 is adjusted to balance the amplitude of the plate currents of V1 and V2. Split-stator capacitor C2 is adjusted to provide an exact 180° phase difference between the synthesizer signals applied to the two control grids. When the modulator is correctly balanced, neither the synthesizer frequency nor the modulation frequency appears in the output (with circuits tuned to proper sideband), and only the desired product of the two signals is amplified by the rf amplifier stages.

(2) DRIVER AND POWER AMPLIFIERS. -- The driver amplifiers (V3 and V4) drive the power amplifier (V5). The driver amplifier stages are conventional grounded-cathode rf amplifier stages. The input resonant circuit of V3, along with the input and output resonant circuits of V4, are tuned by the DRIVER TUNING control. During cw operation, the synthesizer signal is coupled to the input resonant circuit of V3. When the balanced modulator is used, the synthesizer connection is removed from the grid circuit of V3 and connected to the balanced modulator. A resonant plate circuit of the balanced modulator is capacitance coupled to an input resonant circuit of V3. Both of these circuits are selected by BAND SELECTOR S1, and tuned by the DRIVER TUNING control. (The DRIVER TUNING control is secured by the adjacent DIAL LOCK, when not in use.)

The screen-grid voltages of V3 and V4 are obtained from the +300 volt supply, dropped to +160 volts and regulated by zener diode CR1. The zener diode maintains the voltage of +160 volts and also filters out residual primary power hum. Plate

voltages for V3 and V4 are obtained through dropping resistors from the +300 volt supply. The application of both screen and plate voltages is controlled by TEST KEY S4 or by the keying relay in the power supply.

Power amplifier V5 is a ceramic tetrode operating as a class A linear amplifier. Signal from the 2nd driver amplifier V4 is coupled through C69 to the input of the power amplifier V5. The output of V5 is developed in the resonant plate circuit of V5. Variable inductor L24 tunes the resonant plate circuit selected by the BAND SELECTOR.

(3) CONTROLS AND INDICATORS. -- The radio frequency amplifier has the following controls and indicators on the front panel:

RF DRIVE
BAND SELECTOR
DRIVER TUNING
Driver tuning DIAL LOCK
PA TUNING
TUNE/OPERATE
TEST KEY
RF OUTPUT (meter)
INTERLOCK DISABLED (indicator)
PA tuning DIAL LOCK

The RF DRIVE control is a dual potentiometer (R33) located in an attenuator in the input line from the synthesizer. An additional input attenuator circuit, consisting of R38, R39, and R40, is switched to the synthesizer line by the CW MOD switch S6 when the transmitter group is used in the cw mode of operation.

The RF DRIVE control remains in the synthesizer line regardless of mode of operation. The RF DRIVE control is used to vary the amount of input attenuation, and hence, the level of the signal driving the radio frequency amplifier.

The BAND SELECTOR selects tank circuits for the driver stages and capacitance for the power amplifier output impedance matching pi-section. The BAND SELECTOR has the following band positions: 2-4 mc, 4-8 mc, 8-16 mc, 16-23 mc, and 23-32 mc. At each position of the BAND SELECTOR, the DRIVER TUNING control, C10, is used to vary the capacitance of the driver tuned circuits. On the two highest frequency bands (16-23 and 23-32) only sections B, D, F, and H of the DRIVER TUNING ganged capacitor C10 are used. Operating the PA TUNING control varies the continuous tap of L24 in the power amplifier output impedance matching pi-section. Coil L24 is an air-wound helix with tapered turns-spacing. The tap of L24 is a roller which rides the conductor forming the helix, and advances along the helix, which rotates when PA TUNING control is turned. The PA TUNING control is secured by the adjacent DIAL LOCK, when not in use.

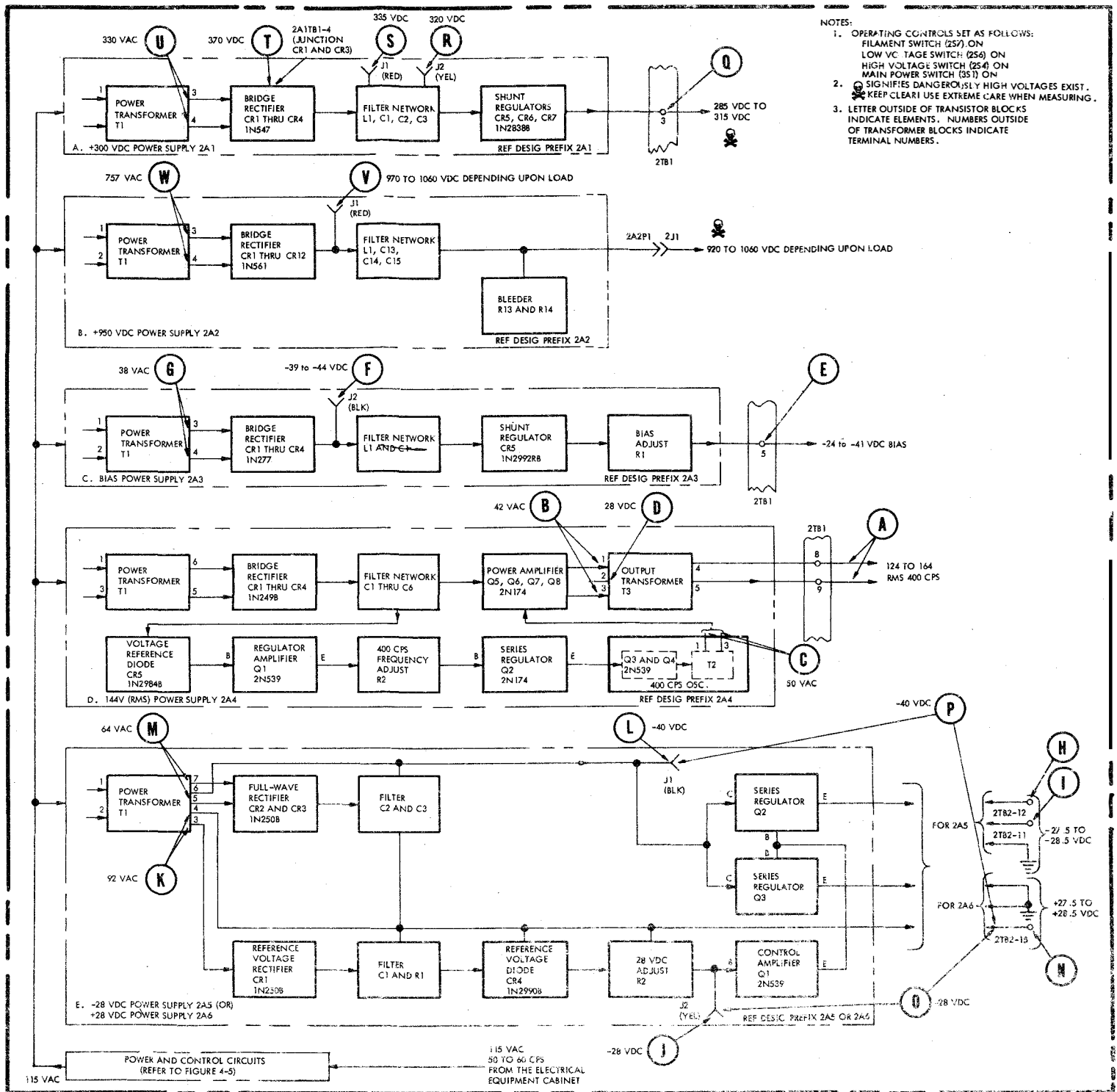

Figure 4-2. Power Supply PP-2796/WRA-3,
Unit 2, Functional Section
Servicing Block Diagram

TABLE 4-2. TYPICAL METER INDICATIONS

BAND SELECTOR	FREQUENCY (MC)	RF DRIVE SETTING	PA PLATE CURRENT (MA)	REMARKS
2-4	2.5	4.0	210	TUNE/OPERATE switch in TUNE position; RF DRIVE set for full scale deflection of RF OUTPUT meter (15 watts).
2-4	3.5	2.5	215	
4-8	4.5	3.0	200	
4-8	7.5	1.5	205	
8-16	9	5.5	210	
8-16	14	4.0	210	
16-23	17	3.0	210	
23-32	23	5.5	210	
23-32	25	5.5	215	
23-32	31	7.0	220	

The neutralization network of the power amplifier consists of capacitors C69 through C72 and C80, the tuned plate circuit of the driver amplifier V4, and the grid circuit of the power amplifier V5. This network neutralizes the plate-to-grid interelectrode capacitance of V5. When adjusted at the frequency of 23 mc, capacitor C71 provides effective neutralization over the 2-32 mc frequency range.

Front panel controls of the radio frequency amplifier are mechanically linked to circuit elements and indicator dials through the gear box, 1MP 15, located directly behind the front panel. The BAND SELECTOR control is mechanically linked to bandswitching circuits and to the DRIVER TUNING and PA TUNING indicator masks. Bead chain drives position the indicator masks, as the BAND SELECTOR control is switched. The masks cover indicator scales that are not applicable to the selected band, permitting only the scales for the selected band to be viewed. The BAND SELECTOR control cannot be turned until BAND SELECTOR RELEASE control is held in RELEASE position. The BAND SELECTOR RELEASE control is mechanically linked to the band selector detent bar. The detent bar opens the band selector switch interlock 1S7 when the BAND SELECTOR RELEASE control is turned, deenergizing the high voltage circuit. In addition, the band selector detent prevents the detent bar from returning to normal position and prevents the closure of 1S7, until the bandswitch contacts are closed. The TUNE OPERATE control is

mechanically coupled to the tune operate switch 1S3. During switching of 1S3, the tune operate interlock switch 1S8 opens momentarily, deenergizing the high voltage circuit. Conventional gear trains or mechanical coupling is used for other front panel controls of the radio frequency amplifier.

The output line contains a low pass filter (FL1) and an attenuator which may or may not be used. When the transmitter group is used as an exciter, the attenuator is connected into the line, and the output level is reduced from 15 watts to 1.5 watts. The low pass filter passes frequencies up to 32 mc and attenuates higher frequencies. The cut-off frequency of the filter is 40 mc.

The TUNE OPERATE control is a coaxial switch, S3, which switches the output of the power amplifier to the output line, in the OPERATE position, or to a 50-ohm dummy-load resistor, R36, in the TUNE position. The TEST KEY, S4, controls the application of plate and screen voltages to the balanced modulator and driver stages and screen voltage to the power amplifier for test purposes. The TEST KEY is normally set in the off (center) position when the transmitter group is used with auxiliary equipment or external hand key.

The RF OUTPUT meter, M1, is a 0-1 milliammeter connected to an rf sampling circuit. The meter indicates the relative power level of rf output, and is used to determine peak condition when tuning the radio frequency amplifier.

h. RADIO FREQUENCY AMPLIFIER FUNCTIONAL SECTION TEST DATA. -- Information which will aid in determining whether a malfunction is present in the radio frequency amplifier is as follows.

(1) CONTROL SETTINGS. -- Refer to table 4-1 for proper control settings. The transmitter group should be connected for type A1 emission (paragraph 3-2b(1)(b), steps 1 through 3) and direct transmission at 15 watts (paragraph 3-2b(1)(b)1, steps 1 and 2). Tuning controls should be set to desired frequency and band.

(2) TEST EQUIPMENT AND SPECIAL TOOLS. -- For rf measurements used Multimeter AN/USM-116 or Hewlett-Packard 410B. For ac or dc measurements use Multimeter AN/PSM-4. For vacuum tube measurements, use Socket Adapter Test Kit AN/USM-119, when applicable. There are no requirements for special tools.

(3) PERFORMANCE INDICATORS. -- Refer to table 4-2 for typical meter indications. These indications are typical when the transmitter group is "set up" for type A1 emission.

(4) TEST POINTS. -- Test points are used to facilitate trouble shooting. The test points used in isolating a malfunction to a functional section are identified by a capital letter enclosed within a circle as (A). In the text the test point is identified by a circle followed by the applicable letter as oA, oB, etc. See figure 4-3 for circuit location of test points and figure 5-1 for the physical location of test points.

(5) TESTS. -- Perform the following test to determine whether the radio frequency amplifier functional section is faulty. Once the fault has been isolated to a particular stage, refer to figure 5-16 for additional voltage and resistance data. Note that the balanced modulator checks, step 9, are to be omitted unless auxiliary equipment (refer to NAVSHIPS 0967-047-7010 for details) is used and trouble in the balanced modulator is indicated.

WARNING

DANGEROUSLY HIGH VOLTAGE (APPROXIMATELY 1000 VOLTS) IS PRESENT IN THE RADIO FREQUENCY AMPLIFIER AND MAY CAUSE SERIOUS INJURY OR DEATH IF PERMITTED TO CONTACT THE BODY. USE EXTREME CAUTION WHEN TROUBLE SHOOTING WITH DRAWER INTERLOCKS DISABLED. PRIOR TO ATTEMPTING ANY VOLTAGE MEASUREMENTS, PRESS HIGH VOLTAGE OFF SWITCH 2S5, AND CONNECT METER LEADS; DO NOT PRESS HIGH VOLTAGE ON SWITCH 2S4 UNTIL PERSONNEL ARE CLEAR OF EXPOSED EQUIPMENT. DO NOT RELY ON DRAWER INTERLOCK SWITCHES TO DEENERGIZE HV CIRCUITS.

CAUTION

DO NOT OPERATE POWER AMPLIFIER 1V5 WITH ACCESS COVERS OFF LONGER THAN ABSOLUTELY NECESSARY. UNDER THIS CONDITION, TUBE WILL NOT RECEIVE SUFFICIENT COOLING AIR AND WILL BE DAMAGED IF THE CONDITION IS PROLONGED.

- Step 1. Press HIGH VOLTAGE OFF button located on power supply. (HIGH VOLTAGE READY lamp lights.)
- Step 2. Withdraw radio frequency amplifier drawer from cabinet (paragraph 4-3a(3)), and tilt up.
- Step 3. Defeat drawer interlock switch 1S5, figure 2-5.
- Step 4. Connect Multimeter AN/USM-116 AC probe to ungrounded end of 1R36 and ground probe to ground, test point oB, figures 4-3 and 5-10 (sheet 2).
- Step 5. Press HIGH VOLTAGE ON button. (HIGH VOLTAGE ON lamp lights.)
- Step 6. Adjust RF DRIVE control (1R33) for normal indication of approximately 28 to 35 vrms on multimeter. Refer to table 4-2. If indication is normal, check meter 1M1 and rf sampling network 1R28 through 1R30, 1CR2, 1C25, and associated capacitors. See figure 5-10 (sheets 3 and 4). If indication is high and/or uncontrollable (with RF DRIVE control set to 0), check power amplifier neutralization, paragraph 5-3d(2)(c). If normal indication cannot be obtained, proceed to next step.
- Step 7. Connect multimeter AC probe to pin 6 of 1V4 tube adapter; test point oC, figures 4-3 and 5-10 (sheet 4). Adjust RF DRIVE control, as required, to obtain normal indication of 8.0 to 11.5 vrms on multimeter. If indication is normal, check 1V4 and associated circuits, figure 5-3 (sheet 1), and bias adjust, paragraph 5-3d(1)(b). If proper indication cannot be obtained, proceed to next step.
- Step 8. Connect multimeter AC probe to pin 2 of 1V4 tube adapter, test point oD, figure 4-3 and 5-10 (sheet 4). Adjust RF DRIVE control, as required, to obtain normal indication of 0.18 to 0.26 vrms on multimeter. If indication is normal, deenergize equipment (paragraph 3-2b(4)(a)) and check 1V4 and associated circuit.

Step 9.* Leave (or connect) multimeter AC probe to pin 2 of 1V4 tube adapter. Connect 1P4 to 1J9 (figure 3-5). Place cw-mod switch 1S6 in mod position. Adjust RF DRIVE control, as required, to obtain normal indication of 0.18 to 0.26 vrms on multimeter. (Note that the synthesizer, radio frequency amplifier and auxiliary equipment must be properly tuned for correct balanced modulator use; refer to NAVSHIPS 0967-047-7010. If unable to obtain proper reading, check 1V1 and 1V2, and associated circuit (figure 5-10, sheet 4).

i. MISCELLANEOUS TROUBLE-SHOOTING DATA.

In addition to the three functional sections listed in paragraphs 4-3c, 4-3e, and 4-3g, there are other circuits that are either a combination of, or separated from, said functional sections. This includes circuits located in the synthesizer, radio frequency amplifier, power supply, electrical equipment cabinet, interconnecting unit, and the relay assembly. Also included are circuits related to government furnished material.

In essence these circuits provide for the control, power and interconnection of various switching functions throughout the transmitter group.

The following information provides a description of these circuits, and, where applicable, a troubleshooting procedure.

(1) CONTROL and POWER CIRCUITS. (See figure 4-5 (sheets 1 and 2).) -- The control and power circuits ensure the proper turn-on sequence of six separate power supply assemblies. In addition, the control circuits provide overload protection for the power supplies and associated circuits.

(a) TURN-ON SEQUENCE. (See figure 4-5 (sheet 1).) -- Power is applied to the transmitter group by placing the MAIN POWER switch (electrical equipment cabinet), the FILAMENT switch (power supply) and the LOW VOLTAGE switch (power supply) in their ON positions. With the MAIN POWER switch (3S1) in the ON position, the synthesizer can be turned on to warm up. After the FILAMENT switch (2S7) is placed in the ON position, cabinet blowers (3B1 and 3B2) operate and auxiliary equipment powered by the 144 vac 400 cps power supply (2A4) operates. The FILAMENT indicator (2DS7) lights and the 400 cycle blower (1B1) in the radio frequency amplifier and the 400 cycle blower (2B1) in the power supply operates; also the filament transformers (1T3 and 1T4) in the radio frequency amplifier are energized. A thermal delay relay (1S2) in the radio frequency amplifier obtains heater power from the power amplifier filament transformer. When the LOW VOLTAGE switch is placed in the ON position, the

28 vdc and bias power supplies (2A3, 2A5 and 2A6) are energized. At this time the LOW VOLTAGE indicator lights. Thirty seconds after the FILAMENT switch is ON, the contacts of the thermal delay relay close (figure 4-5 (sheet 2)), and assuming that the radio frequency amplifier interlock (1S5) is closed, +28 vdc power is applied to: band-switch interlock (1S7), tune-operate interlock (1S8), power supply interlock (2S2), screen overload relay (2K2), plate overload relay (2K3), and through a portion of the high voltage relay (2K4) where the H.V. READY indicator (2DS4) lights. With the H.V. READY indicator lighted, the H.V. ON button (2S4) can be pressed, thus energizing the high voltage relay 2K4, which in turn energizes the +300 (2A1) and +950 (2A2) power supplies. At the same time the H.V. ON indicator (2DS5) lights and power is removed from the H.V. READY indicator. With the +300 and +950 volt power supplies energized, 300 volts are applied to the radio frequency amplifier driver and 950 volts are supplied to the power amplifier plate current meter 2M1 and to the power amplifier 1V5.

(b) PROTECTIVE CIRCUITS. -- Protective devices in the power supply functional section include primary and secondary power fuses and a high voltage interlock line. Only the 144 vac 400 cycle (Quasi square wave) supply (2A4) has fuses in its output lines. Each of the power supply assemblies has a fuse in its primary line. The power supply also houses the fuses for the filament transformers and the blowers.

The high voltage interlock line (figure 4-5, sheet 2) is a series circuit containing seven sets of contacts which must be closed for operation of the high voltage relay (2K4). Included in the interlock line are: contacts in two drawer-closed interlock switches, 1S5 and 2S2, the high voltage thermal time delay 1S2, bandswitch interlock 1S7, tune-operate switch interlock 1S8, and overload relays 2K2 and 2K3 for the rf power amplifier plate and screen voltages. The overload relays trip at 35 ma (screen current) and 240 ma (plate current). The relays are reset by means of SCREEN OVERLOAD RESET 2S1, and PLATE OVERLOAD RESET 2S3. The interlock line is associated with the following indicators: INTERLOCK DISABLED (radio frequency amplifier drawer), INTERLOCK DISABLED (power supply drawer), SCREEN OVERLOAD (power supply drawer), PLATE OVERLOAD (power supply drawer), and READY (power supply drawer).

(c) KEYING RELAY. -- Keying relay 2K1 (figure 4-5, sheet 2) enables the transmitter group to be keyed by an external hand key. The hand key, when closed, applies ground to the keying relay, energizing the relay. When energized, the keying relay applies the output of the +300 volt dc power supply to the plates and screen grids of the low level driver tubes and to the screen grid of the power amplifier tube, allowing transmission. When the hand key is released, the ground is removed from the keying relay which then deenergizes.

* Applicable only when AN/WRA-3 is used with auxiliary equipment.
ORIGINAL

Deenergizing the keying relay removes the +300 volt dc from the tubes in the radio frequency amplifier and transmission ceases. The circuit, composed of 2R6, 2L1, 2C6, 2R7, 2R5, and 2C5, provides for shaping of the keyed waveform.

(d) DIRECT TRANSMISSION APPLICATION. -- When the transmitter group is used for direct transmission, the control and power circuit applications are identical to those listed in paragraph 4-3i(1), with power output being applied through the rf attenuator bypass connector (P5) J5 (P6)), filter (FL1) and TUNE-OPERATE switch S3, directly to a patch panel and applicable antenna.

(e) EXCITER APPLICATION. -- When the transmitter group is used as an exciter for larger transmitters such as the AN/URC-32 and the AN/WRT-2, the control and power circuit applications are identical with the following exception: the keying relay 2K1, (figure 4-5, sheet 2), of the transmitter group, in addition to performing its original function, is used to key the applicable transmitter. Also, the power output is applied through the rf attenuator, filter (FL1) and TUNE-OPERATE switch S3, to Transmitter Transfer Control C-6562/WRA-3. Refer to Supplement to NAVSHIPS 93319(A) and Supplement to NAVSHIPS 93285(A) for further details covering the use of the AN/WRA-3 with the AN/URC-32 and the AN/WRT-2.

(2) INTERCONNECTING UNIT MX-3645/WRA-3. (See figure 5-15.) -- The interconnecting unit contains two 47 ohm resistors and cabling for inputs and outputs of auxiliary equipment. Resistor R1 terminates the 1 mc output of the electrical frequency synthesizer in its characteristic impedance. Resistor R2 is a load resistor for balanced modulator input transformer 1T1, in the radio frequency amplifier.

(3) ELECTRICAL EQUIPMENT CABINET CY-3022/WRA-3. (See figure 5-14.) -- The electrical equipment cabinet provides for the primary power for all units of the transmitter group. MAIN POWER switch 3S1 applies primary power through line fuses 3F1 and 3F2 and line filter 3FL1 to autotransformer 3T1, which has taps for 115 or 230 vac primary power input. For 115 vac primary power input, line fuses 3F1 and 3F2 are to be 12 amperes rating. For 230 vac primary power input, line fuses 3F1 and 3F2 are 6 amp fuses. When the MAIN POWER and FILAMENT switches are ON, blowers 3B1 and 3B2 operate to provide cooling air for the cabinet.

(4) RELAY ASSEMBLY RE-754/WRT-4. (See figure 5-18.) -- The relay assembly has double-pole, double-throw switching facilities, controlled by auxiliary equipment. Essentially the relay assembly is an antenna transfer relay, allowing the transmitter group or associated equipment to be switched to the same antenna.

(5) RESILIENT MOUNT MT-2661/WRA-3. (See figure 2-1.) -- The resilient mount is a mechanical device providing for the damping of horizontal and vertical vibrations of the transmitter group.

j. MISCELLANEOUS TEST DATA.

(1) CONTROL SETTING. -- Place MAIN POWER switch 3S1, FILAMENT switch 2S7 and LOW VOLTAGE switch 2S6 in their respective ON positions.

(2) TEST EQUIPMENT AND SPECIAL TOOLS. -- For dc measurement use Multimeter AN/PSM-4. There are no requirements for special tools.

(3) TEST POINTS. -- Test points are used to facilitate trouble shooting. The test points used in isolating the trouble in the control/power and protective circuits are identified by a capital letter and a numeral enclosed within a circle, (A₁). In the text the test point is identified by a circle followed by the applicable letter and numeral -- oA₁, oB₁, etc. See figure 4-5 (sheet 2) for circuit location of test points and figures 5-10 (sheet 2), 5-3 (sheet 3), and 5-12 for the physical location of test points.

(4) TEST. -- Perform the following test to determine whether the control/power and protective circuits are faulty.

(a) CONTROL/POWER AND PROTECTIVE CIRCUITS. (See figure 4-5, sheet 2.)

(1) Perform checks listed in paragraph 4-3b. If unable to isolate malfunction, proceed to next step.

(2) Using multimeter, make measurements at test points oA₁ through oE₁ to ground, figures 4-5 (sheet 2), 5-10 (sheet 2), 5-3 (sheet 3), and 5-12. A normal indication of +28 vdc should register on multimeter at each test point. If unable to obtain correct voltage, trouble shoot circuit between last correct voltage and incorrect voltage reading as indicated in the referenced figure.

(b) INTERCONNECTING UNIT MX-3645/WRA-3. -- Trouble shooting is not required.

(c) ELECTRICAL EQUIPMENT CABINET CY-3022/WRA-3. -- The trouble-shooting procedure for the electrical equipment cabinet consists of making continuity checks, using Multimeter AN/PSM-4 and figure 5-14.

(d) RELAY ASSEMBLY RE-754/WRT-4. -- Trouble shooting the relay assembly required the use of auxiliary equipment. Refer to NAVSHIPS 0967-047-7010 for details.

(e) RESILIENT MOUNT MT-2661/WRA-3. -- Trouble shooting is not required.

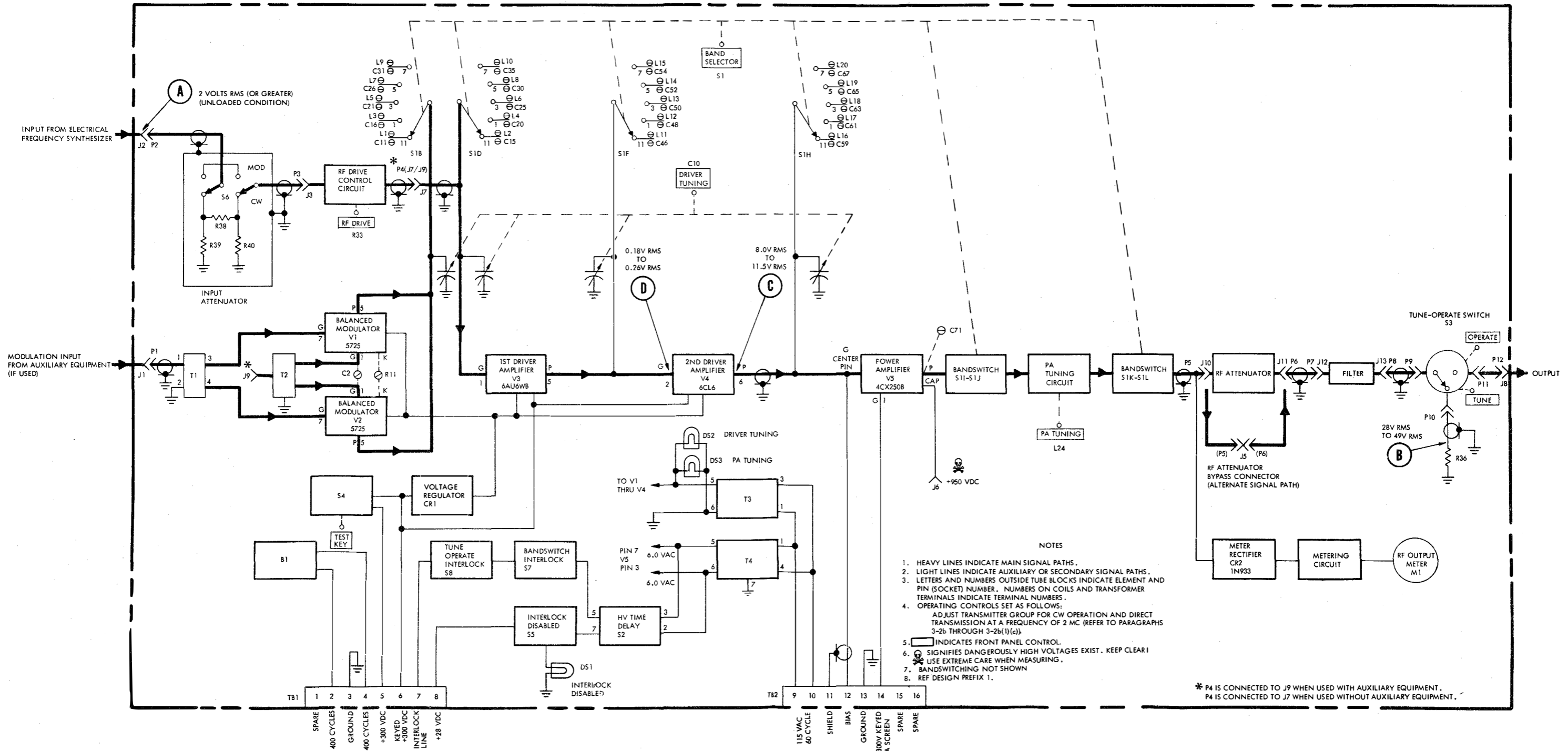

Figure 4-3. Radio Frequency Amplifier AM-2819/WRA-3, Unit 1, Functional Section Servicing Block Diagram

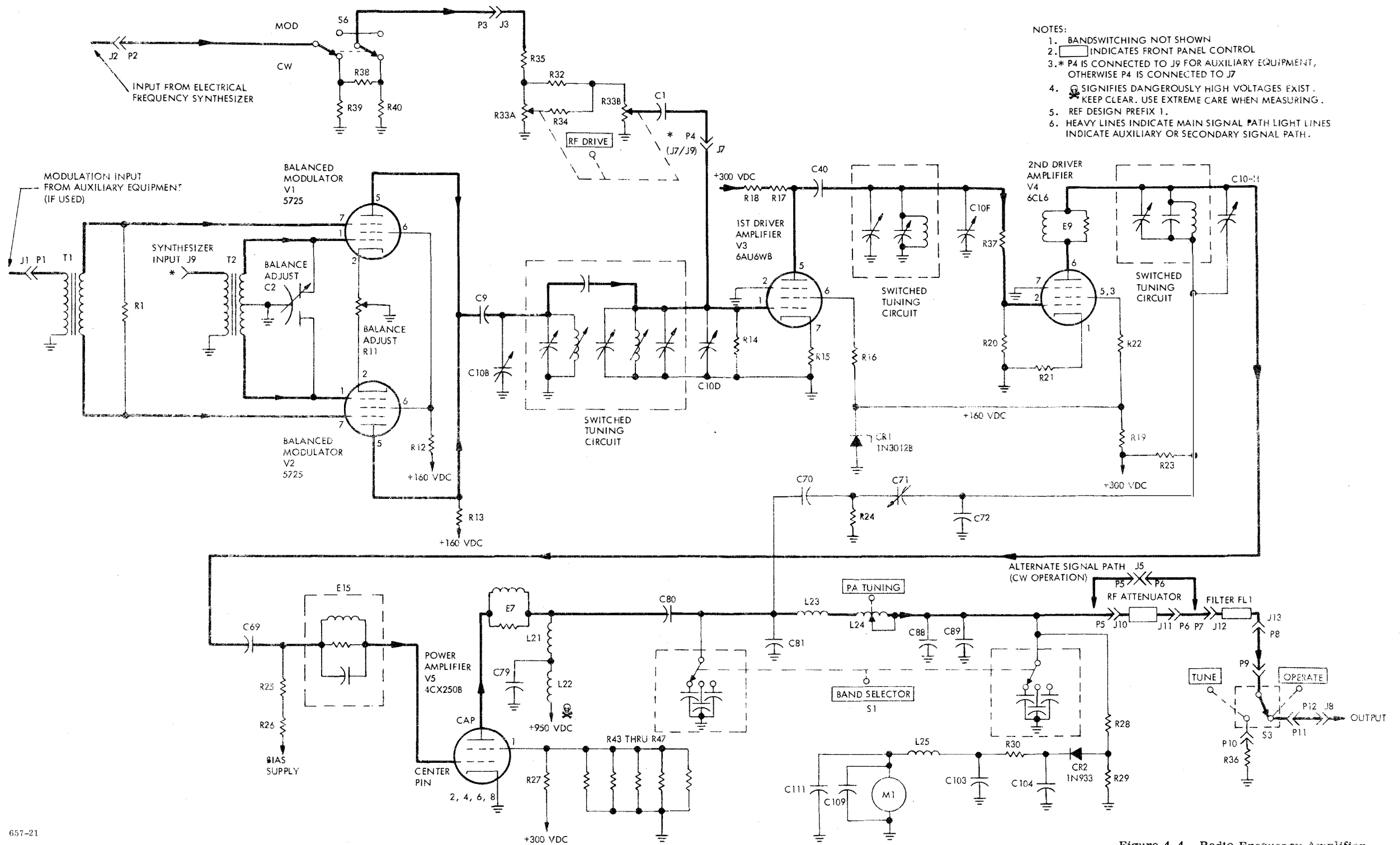
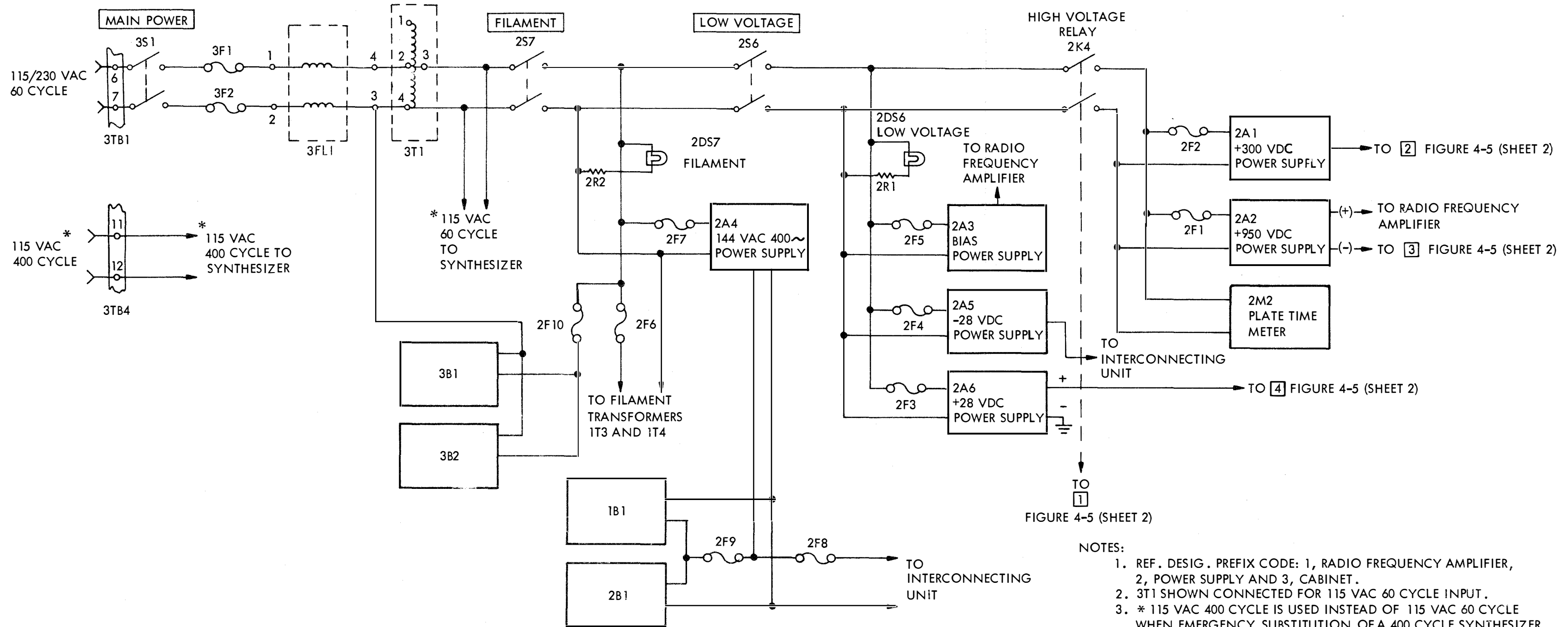

Figure 4-4. Radio Frequency Amplifier
AM-2819/WRA-3, Unit 1, Simplified
Schematic Diagram



- NOTES:
1. REF. DESIG. PREFIX CODE: 1, RADIO FREQUENCY AMPLIFIER, 2, POWER SUPPLY AND 3, CABINET.
 2. 3T1 SHOWN CONNECTED FOR 115 VAC 60 CYCLE INPUT.
 3. * 115 VAC 400 CYCLE IS USED INSTEAD OF 115 VAC 60 CYCLE WHEN EMERGENCY SUBSTITUTION OF A 400 CYCLE SYNTHESIZER IS REQUIRED.
 4. INDICATES FRONT PANEL CONTROL.

657-22-1

Figure 4-5. Transmitter Group AN/WRA-3,
Control and Power Circuits Diagram
(Sheet 1 of 2)

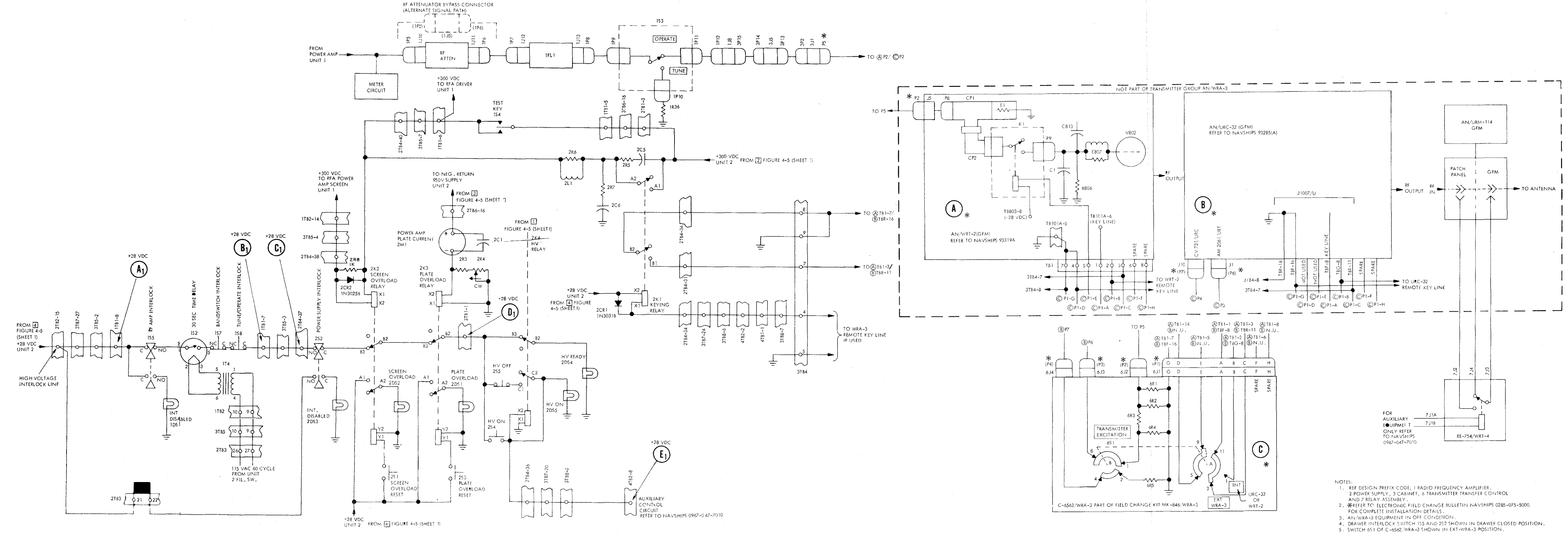

- NOTES:
1. REF DESIGN PREFIX CODE; 1 RADIO FREQUENCY AMPLIFIER, 2 POWER SUPPLY, 3 CABINET, 6 TRANSMITTER TRANSFER CONTROL AND 7 RELAY ASSEMBLY.
 2. *REFER TO ELECTRONIC FIELD CHANGE BULLETIN NAVSHIPS 0285-075-5000, FOR COMPLETE INSTALLATION DETAILS.
 3. AN/WRA-3 EQUIPMENT IN OFF CONDITION.
 4. DRAWER INTERLOCK SWITCH 155 AND 252 SHOWN IN DRAWER CLOSED POSITION.
 5. SWITCH 651 OF C-6562/WRA-3 SHOWN IN EXT-WRA-3 POSITION.

Figure 4-5. Transmitter Group AN/WRA-3, Control and Power Circuits Diagram (Sheet 2 of 2)

SECTION 5
MAINTENANCE

5-1. FAILURE, AND PERFORMANCE AND
OPERATIONAL REPORTS.

NOTE

The Bureau of Ships no longer requires the submission of failure reports for all equipments. Failure Reports and Performance and Operational Reports are to be accomplished for designated equipments (refer to Electronics Installation and Maintenance Book, NAVSHIPS 900,000) only to the extent required by existing directives. All failures shall be reported for those equipments requiring the use of Failure Reports.

5-2. PREVENTIVE MAINTENANCE.

Complete preventive maintenance procedures are included in the Maintenance Standards Book for Transmitter Group AN/WRA-3, NAVSHIPS 0967-031-9030. The maintenance standards book contains a series of maintenance standard test procedures which provide indications representing top performance of the equipment, and a series of maintenance check-off procedures which, when performed as directed, will aid in detecting impending failures before they occur. When standards are not acceptable due to misalignment, tuning and adjustment procedures contained in paragraph 5-3 of this section should bring the transmitter group within standards.

To augment the maintenance information contained in NAVSHIPS 0967-031-9030, this section of the technical manual contains illustrations which locate all maintenance parts and test points. When an adjustment or repair procedure refers to certain components or test points, the illustration showing said components or test points is placed as close as possible to this procedure. Other location diagrams are located toward the end of the section. To locate any specific part, refer to the FIG. NO. column of the maintenance parts list of Section 6. For each maintenance part, this column denotes the figure in which the location of the part is illustrated. Also, refer to figure 2-10 for information pertaining to interunit cabling connections and figure 5-13 for the primary power distribution diagram.

5-3. TUNING AND ADJUSTMENT.

a. GENERAL. -- This paragraph includes the entire tuning and adjustment procedures for the transmitter group, with the exception of Electrical Frequency Synthesizer O-1115/URC, which is government furnished. Refer to NAVSHIPS 94829 for tuning and adjustment procedures relating to

this equipment. After maintenance personnel become thoroughly acquainted with the transmitter group, specific portions of the entire tuning and adjustment procedure may be individually performed if proper control settings and electrical connections are accomplished which relate to the specific procedure.

Detail information relating to the removal of assemblies or parts is not provided in this paragraph. Refer to paragraph 5-4 for removal instructions.

b. TEST EQUIPMENT AND SPECIAL TOOLS. -- Test equipment required during tuning and adjustment of the transmitter group is listed in table 5-2. The only special tool required is an alignment tool included in the radio frequency amplifier unit; see figure 5-10 (sheet 1).

c. CONTROL SETTINGS. -- Refer to table 5-1 for control settings.

d. INSTRUCTIONS. -- Before power is applied to the transmitter group to perform the tuning and adjustment procedures, the following steps must be performed.

Step 1. Connect 50 ohm dummy load to rf output jack 3J1, located at rear of electrical equipment cabinet, figure 2-8.

Step 2. Set front panel controls in positions listed in table 5-1.

Step 3. Perform procedures listed in paragraph 3-2b(1)(b), steps 1 through 3, then prepare transmitter group for 15 watt cw operation at 2mc (direct transmission), as described in paragraph 3-2b(1)(b)1, steps 1 and 2.

(1) ADJUSTMENT OF POWER SUPPLY PP-2796/WRA-3. (See figures 5-1 and 5-17.) -- To perform the procedures listed in this paragraph, loosen the front panel screws on the power supply, extend the drawer, defeat interlock switch 2S2 (figure 2-4), and remove the cover plates. Place MAIN POWER switch 3S1, LOW VOLTAGE switch 2S6, FILAMENT switch 2S7, and synthesizer POWER switch 5S1 to their respective ON positions. After READY lamp lights, press HIGH VOLTAGE ON switch 2S4, then proceed as follows.

WARNING

HIGH VOLTAGES ARE NOW PRESENT AT
TERMINALS AND CONNECTORS WITHIN
POWER SUPPLY, UNIT 2. EXERCISE

EXTREME CAUTION WHEN MAKING
ADJUSTMENTS AND MEASUREMENTS.

(a) PLATE OVERLOAD RELAY CURRENT
ADJUSTMENT.

- Step 1. Set TEST KEY 1S4 in lock (up) position.
- Step 2. Rotate RF DRIVE control to 0.
- Step 3. Rotate plate current overload adjust resistor 2R4 (figure 5-1) completely clockwise.
- Step 4. Rotate BIAS ADJUST 2A3R1 for 240 ma reading on PA PLATE CURRENT meter 2M1, then rotate 2R4 counterclockwise until PLATE OVERLOAD indicator 2DS1 lights.

CAUTION

PLATE CURRENT IN EXCESS OF 250 MA
FOR A PROLONGED LENGTH OF TIME
MAY PHYSICALLY DAMAGE POWER
AMPLIFIER TUBE 1V5.

NOTE

Screen overload indicator 2DS2 may also light during steps 4 and 5. Disregard this indication, but both PLATE OVERLOAD RESET switch 2S3 and SCREEN OVERLOAD RESET switch 2S1 must be pressed.

- Step 5. Rotate BIAS ADJUST 2A3R1 counterclockwise approximately five or more turns, then press HIGH VOLTAGE ON switch 2S4.
- Step 6. Check overload setting by rotating 2A3R1 clockwise until PLATE OVERLOAD indicator 2DS1 lights. PA PLATE CURRENT meter 2M1 should read 240 ma when this occurs, dropping to zero after 2DS1 lights. If a different reading is obtained, 2R4 must be slightly readjusted.
- Step 7. Adjust for proper bias as described in following paragraph.

(b) BIAS POWER SUPPLY 2A3, OUTPUT
ADJUSTMENT.

- Step 1. Set TEST KEY 1S4 in locked (up) position.
- Step 2. Rotate RF DRIVE control to 0.
- Step 3. Press SCREEN OVERLOAD RESET control 2S1, and PLATE OVERLOAD RESET control 2S3, then press HIGH VOLTAGE ON control 2S4.

- Step 4. Adjust BIAS ADJUST 2A3R1 for indication of 190 milliamperes on PA PLATE CURRENT meter 2M1.

(c) +28 VOLT DC POWER SUPPLY 2A6, VOLT-
AGE OUTPUT ADJUSTMENT.

- Step 1. Set MAIN POWER switch 3S1 in OFF position.
- Step 2. Connect Multimeter AN/PSM-4 between 2TB2-15 and ground, figure 5-3 (sheet 3).
- Step 3. Set MAIN POWER switch 3S1 in ON position.
- Step 4. Adjust 2A6R2 (figure 5-1) for indication of +28 volts dc.

(d) -28 VOLT DC POWER SUPPLY 2A5, VOLT-
AGE OUTPUT ADJUSTMENT.

- Step 1. Set MAIN POWER switch 3S1 in OFF position.
- Step 2. Connect Multimeter AN/PSM-4 between 2TB2-12 and ground, figure 5-3 (sheet 3).
- Step 3. Set MAIN POWER switch 3S1 in ON position.
- Step 4. Adjust 2A5R2 (figure 5-1) for indication of -28 volts dc with auxiliary equipment connected and operating.
- Step 5. Connect Multimeter between 2TB2-11 and ground. Meter should read -28 volts dc.

(e) 144 VOLT (RMS) 400 CPS POWER SUPPLY
2A4, FREQUENCY OUTPUT ADJUSTMENT.
(Auxiliary equipment must be connected, refer to
NAVSHIPS 0967-047-7010 for details.)

- Step 1. Set MAIN POWER switch 3S1 in OFF position.
- Step 2. Connect vertical input lead of Oscilloscope AN/USM-117 to 2TB-7, and ground lead to 2TB1-9, figure 5-3 (sheet 3).
- Step 3. Set MAIN POWER switch 3S1 in ON position.
- Step 4. Set test equipment in operating condition for single cycle presentation.
- Step 5. Adjust 2A4R2 (figure 5-1) for a single cycle period of 2.50 milliseconds (400 cps) pattern on oscilloscope display with auxiliary equipment connected and operating.
- Step 6. Set MAIN POWER switch in OFF position.
- Step 7. Disconnect test equipment, replace cover plates, and secure power supply, unit 2.

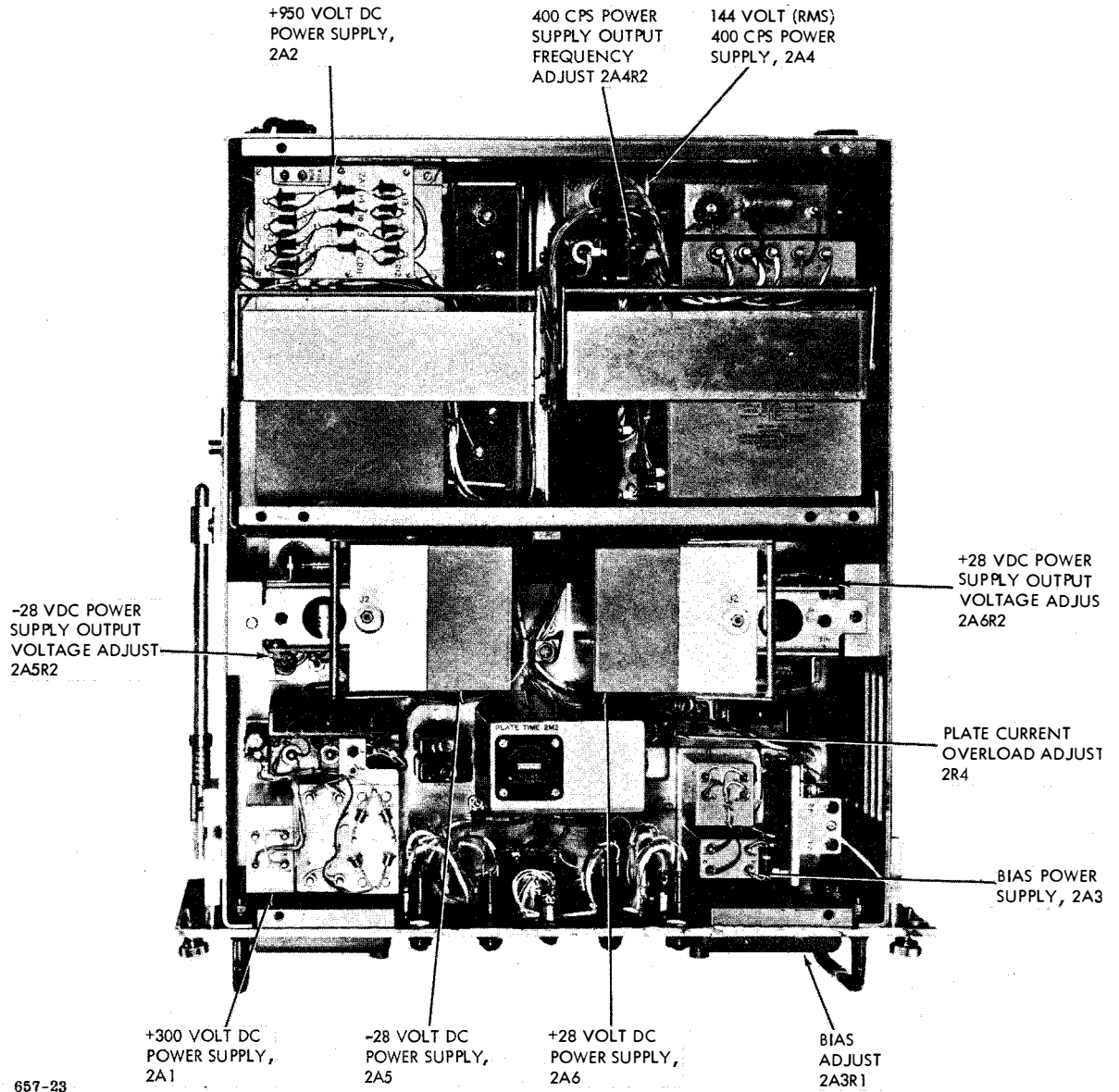

Figure 5-1. Power Supply PP-2796/WRA-3, Unit 2, Top View, Assembly and Adjustment Locations

(2) ADJUSTMENT OF RADIO FREQUENCY AMPLIFIER AM-2819/WRA-3. (See figures 5-2, 5-13, and 5-16.) -- Perform the procedures listed in paragraph 5-3d; loosen the front panel screws on the radio frequency amplifier, extend the drawer, defeat interlock switch 1S5 (figure 2-5), remove cover plates, then proceed as follows.

1V5 WITH ACCESS COVERS OFF LONGER THAN ABSOLUTELY NECESSARY. UNDER THIS CONDITION, TUBE WILL NOT RECEIVE SUFFICIENT COOLING AIR AND WILL BE DAMAGED IF THE CONDITION IS PROLONGED.

CAUTION

DO NOT OPERATE POWER AMPLIFIER

WARNING

HIGH VOLTAGES ARE PRESENT AT TERMINALS AND CONNECTORS WITHIN THE

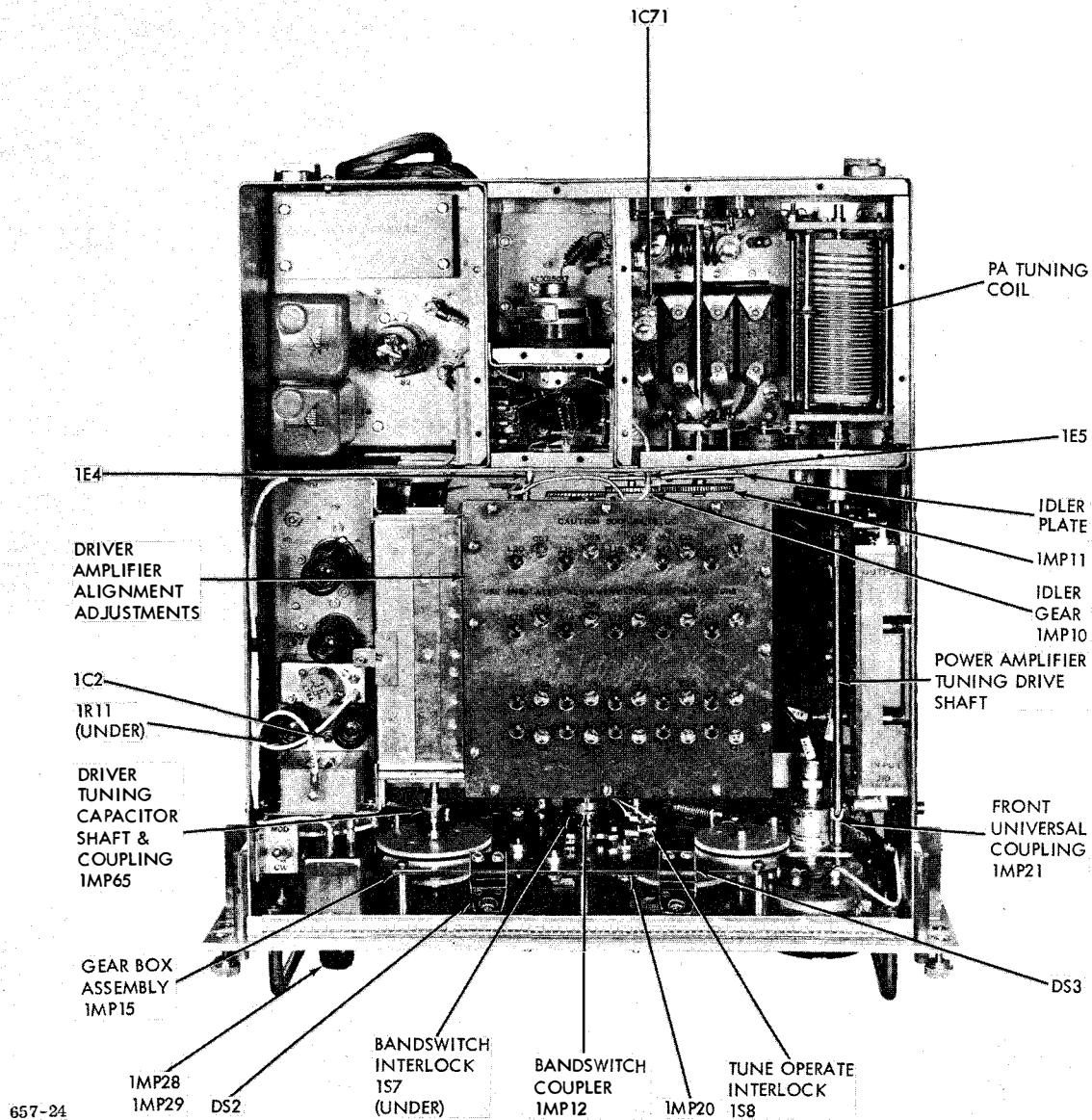

Figure 5-2. Radio Frequency Amplifier AM-2819/WRA-3, Unit 1, Adjustment Locations

RADIO FREQUENCY AMPLIFIER. EXERCISE EXTREME CAUTION WHEN MAKING ADJUSTMENTS AND MEASUREMENTS.

(a) DRIVER AMPLIFIER ALIGNMENT.

Step 1. Disconnect plug 3P8 from jack 1J1 (figures 5-10, sheet 2 and 5-14), then connect output of Signal Generator CAQI-606-A to jack 1J1.

Step 2. Disconnect plug 1P4 from jack 1J7 and connect it to jack 1J9, located on top of transformer 1T2 (figure 5-10, sheet 4).

Step 3. Set cw/mod switch 1S6 (figure 5-10, sheet 1) in mod position.

Step 4. Connect plugs 1P5 and 1P6 to jack 1J5 (figure 5-10, sheet 2), bypassing rf attenuator.

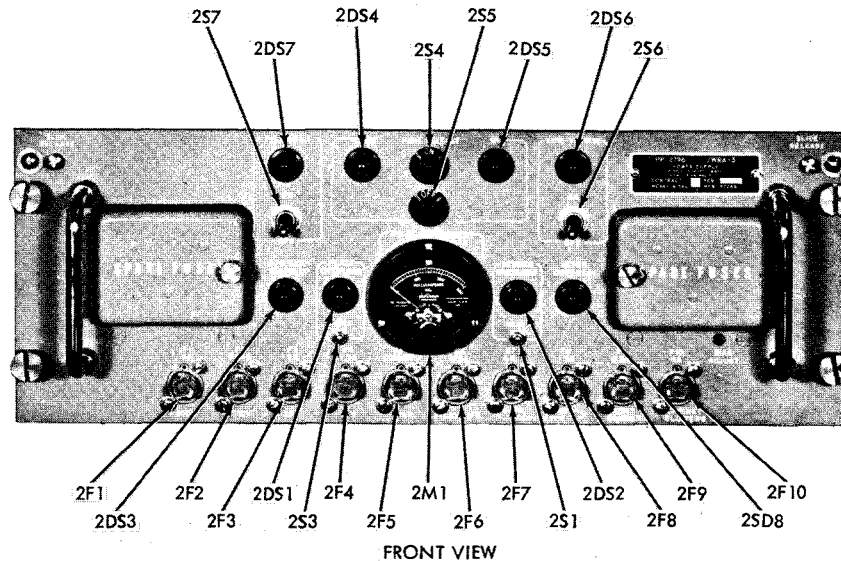

657-25-1

Figure 5-3. Power Supply PP-2796/WRA-3, Unit 2, Test Points and Parts Location
(Sheet 1 of 3)

- | | |
|--|---|
| <p>Step 5. Set electrical frequency synthesizer and Signal Generator CAQI-606-A for 2 mc output (according to table 5-3), then set BAND SELECTOR, DRIVER TUNING, and PA TUNING controls for same frequency, then perform synthesizer adjustments given in paragraph 3-2b(2)(a).</p> <p>Step 6. Start transmitter group by performing steps 1 through 16 of paragraph 3-2b(1)(c). Do not adjust tuning controls for peak indication.</p> <p>Step 7. If large output is indicated on RF OUTPUT METER 1M1 and cannot be reduced by adjusting RF DRIVE control, perform the next step. If indication is normal or low, and gain can be adjusted by RF DRIVE control, omit the next step.</p> <p>Step 8. Adjust capacitor 1C71 (figure 5-10, sheet 1) for zero deflection on RF OUTPUT meter and perform neutralization procedure of paragraph 5-3d(2)(c).</p> <p>Step 9. Adjust Signal Generator CAQI-606-A output for 0.8 volt.</p> <p>Step 10. Adjust RF DRIVE control for midscale reading on RF OUTPUT meter. Adjust for peak indication on RF OUTPUT meter by adjusting slugs of following inductors, in order stated: 1L16, 1L11, 1L2, and 1L1 (figure 5-10, sheet 4). (Reduce setting of RF DRIVE control as necessary to prevent meter needle from pegging.)</p> | <p>Step 11. Reset controls for frequency of 4 mc in 2-4 mc band (see table 5-3), then adjust trimmer capacitors in following order: 1C59, 1C46, 1C15, and 1C11 for peak indication on RF OUTPUT meter.</p> <p>Step 12. Repeat step 10 and 11 for optimum alignment.</p> <p>Step 13. Table 5-3 lists the settings required in tuning the transmitter group to extreme ends of each band. Repeat steps 1 through 12 for each band, using settings and adjustments listed in table 5-3.</p> <p>Step 14. Press HIGH VOLTAGE OFF switch 2S5, then set other controls in positions listed in table 5-1.</p> <p>Step 15. Reconnect 3P8 to 1J1, 1P4 to 1J7; disconnect 1P5 and 1P6 from 1J5, disconnect test equipment.</p> <p>(b) MODULATOR BALANCING ADJUSTMENT.
-- The following procedure described the steps necessary to balance the balanced modulator stage of the radio frequency amplifier. (When auxiliary equipment is installed, refer to NAVSHIPS 0967-047-7010 for balancing procedure.)</p> <p>Step 1. Disconnect plug 1P4 from jack 1J7 and connect it to jack 1J9 located on top of transformer 1T2 (figure 5-10, sheet 4).</p> <p>Step 2. Disconnect jack 1J1 from plug 3P8 (figures 5-20, sheet 2 and 5-14), then connect output of RF Signal Generator CAQI-606-A to jack 1J1.</p> |
|--|---|

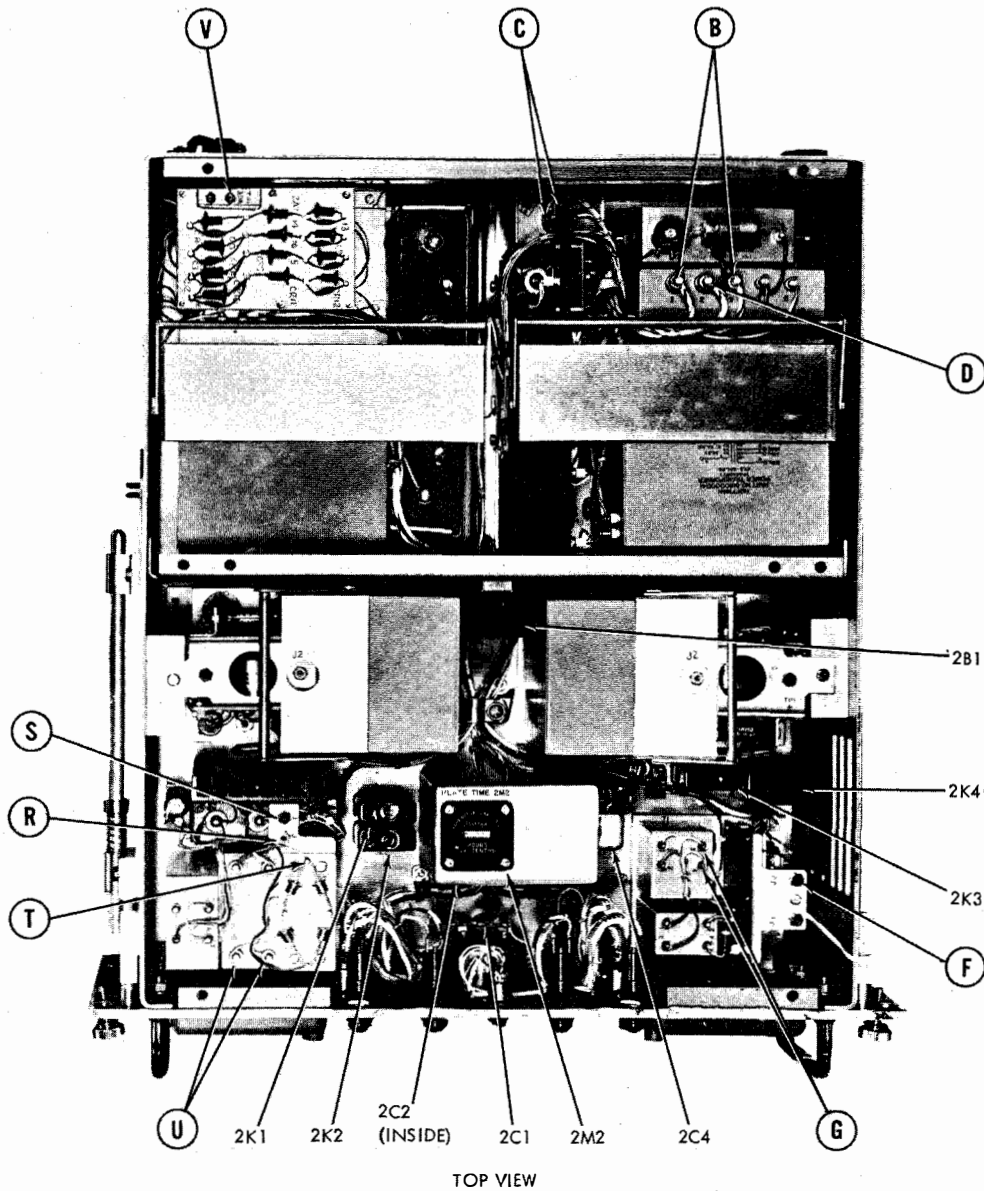

657-25-2

Figure 5-3. Power Supply PP-2796/WRA-3, Unit 2, Test Points and Parts Location
(Sheet 2 of 3)

- | | |
|--|---|
| <p>Step 3. Set cw mod switch 1S6 (figure 5-10, sheet 1) in mod position.</p> <p>Step 4. Set MAIN POWER switch 3S2 in ON position.</p> <p>Step 5. Set FILAMENT switch 2S7 and LOW VOLTAGE switch 2S6 in ON positions.</p> | <p>Step 6. Disable interlock switch 1S5 (figure 2-5).</p> <p>Step 7. Press HIGH VOLTAGE ON switch 2S4.</p> <p>Step 8. Set TEST KEY 1S4 in locked (up) position.</p> <p>Step 9. Adjust electrical frequency synthesizer for output of 2 volts at 4.0 mc.</p> |
|--|---|

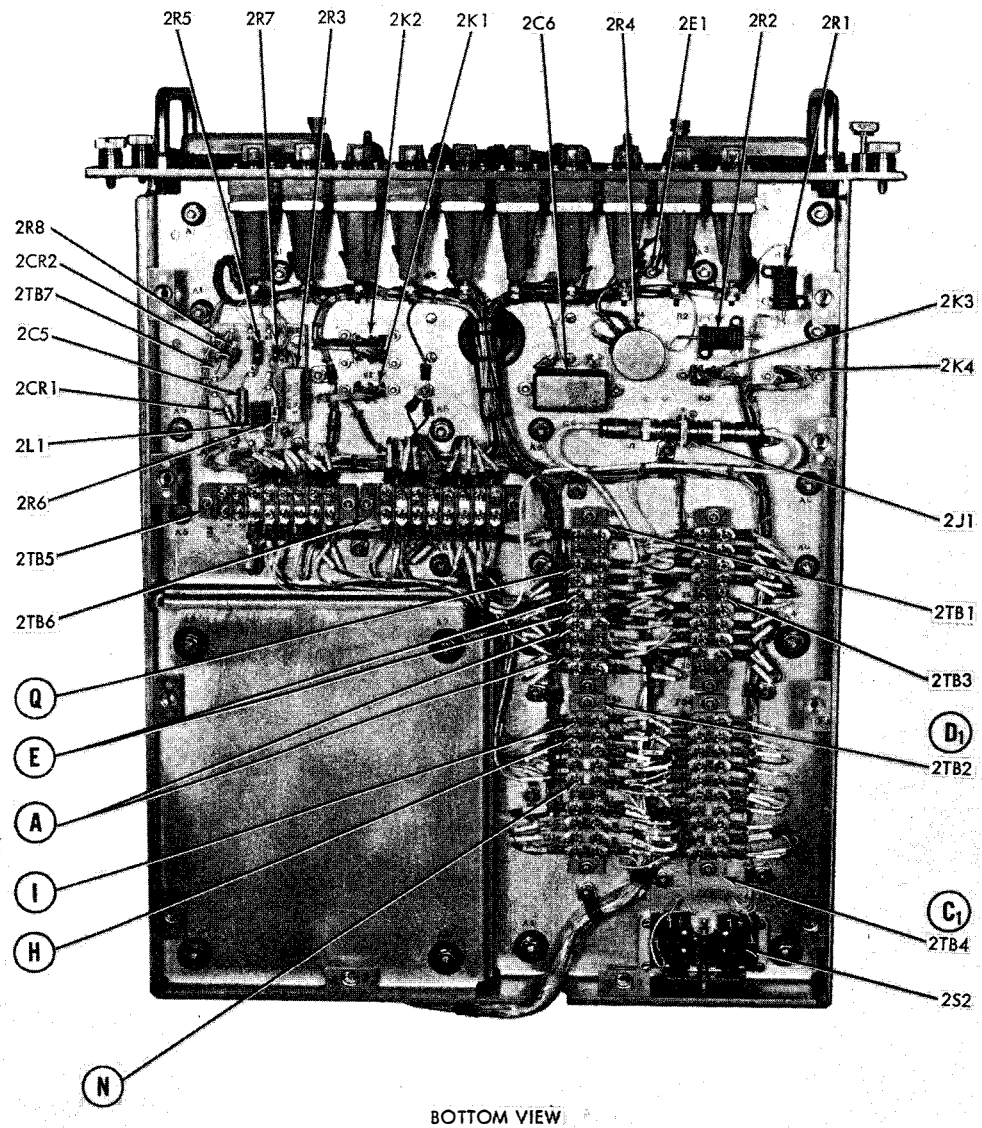

657-25-3

Figure 5-3. Power Supply PP-2796/WRA-3, Unit 2, Test Points and Parts Location
(Sheet 3 of 3)

- Step 10. Adjust RF Signal Generator CAQI-606-A for output of 0.8 volt at 0.5 mc.
- Step 11. Set BAND SELECTOR, DRIVER TUNING, and PA TUNING controls of radio frequency amplifier for 4.0 mc output. (Press HIGH VOLTAGE ON switch 2D4 if new band was selected.)
- Step 12. Increase RF DRIVE control setting, and peak tuning controls, observing RF

- OUTPUT meter 1M1.
- Step 13. Adjust resistor 1R11 (figure 5-10, sheet 5) for minimum deflection of RF OUTPUT meter 1M1.
- Step 14. Advance RF DRIVE control and repeat step 13 to obtain minimum deflection point on RF OUTPUT meter 1M1.
- Step 15. Adjust electrical frequency synthesizer, unit 5, for output at 28.5 mc.

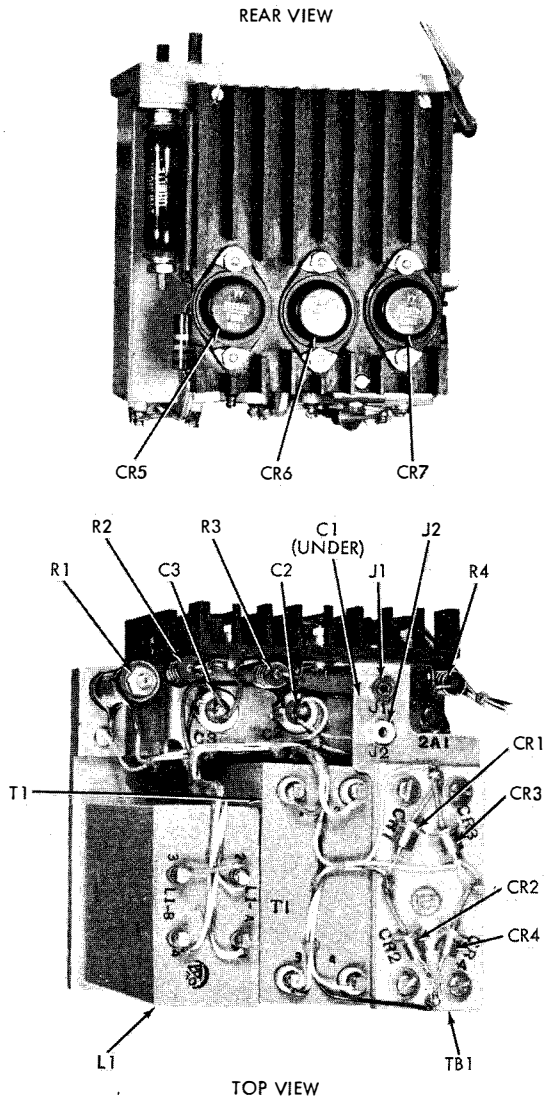

657-26

REF DESIG PREFIX 2A1

Figure 5-4. +300 Volt DC Power Supply,
Assembly 2A1, Test Points
and Parts Location

- Step 16. Adjust RF Signal Generator CAQI-606-A for output of 0.8 volt at 3.5 mc.
- Step 17. Set BAND SELECTOR, DRIVER TUNING, and PA TUNING controls for output at 28.5 mc.
- Step 18. Advance RF DRIVE control and adjust capacitor 1C2 (figure 5-10, sheet 5) to obtain minimum deflection point.
- Step 19. Repeat steps 9 through 13.
- Step 20. Set MAIN POWER switch 3S1, FILAMENT switch 2S7, and LOW VOLTAGE switch 2S6 in OFF positions.
- Step 21. Disconnect plug 1P4 from jack 1J9 and reconnect it to jack 1J7.
- Step 22. Disconnect Signal Generator CAQI-606-A and reconnect jack 1J1 to plug 3P8.
- Step 23. Set cw mod switch 1S6 in cw position.
- Step 24. Slide radio frequency amplifier into cabinet and tighten captive mounting screws.
- (c) AMPLIFIER NEUTRALIZATION. -- The following procedure described the steps necessary to neutralize the radio frequency amplifier. The transmitter group must be set in cw operation as specified in paragraph 5-3d, step 3, before this procedure may be accomplished.
- Step 1. Set MAIN POWER switch 3S1 in ON position.
- Step 2. Set FILAMENT switch 2S7 and LOW VOLTAGE switch 2S6 in ON positions.
- Step 3. Press HIGH VOLTAGE ON switch 2S4.
- Step 4. Set TEST KEY 1S4 in locked (up) position.
- Step 5. Adjust electrical frequency synthesizer for output of 23 mc.
- Step 6. Set BAND SELECTOR, DRIVER TUNING, and PA TUNING controls of radio frequency amplifier for 23 mc output on 16 to 23 mc band. (Press HIGH VOLTAGE ON switch 2S4 if new band was selected.)
- Step 7. Increase RF DRIVE control setting, and peak tuning controls, observing RF OUTPUT meter 1M1.
- Step 8. Press HIGH VOLTAGE OFF switch 2S5.
- Step 9. Set FILAMENT switch 2S7, and LOW VOLTAGE switch 2S6 in OFF positions.
- Step 10. Extend radio frequency amplifier and remove bottom rear cover, then disconnect plug 3P21 from jack 1J6, figure 5-10, (sheet 2).
- Step 11. Remove fuse 2F1 from front panel of power supply to disable +950 vdc supply.
- Step 12. Disconnect lead from capacitor 1C78 at terminal board 1TB2-14, figure 5-10 (sheet 2).
- Step 13. Connect cable between output jack 3J1 (figure 2-8) and 50 ohm antenna input of

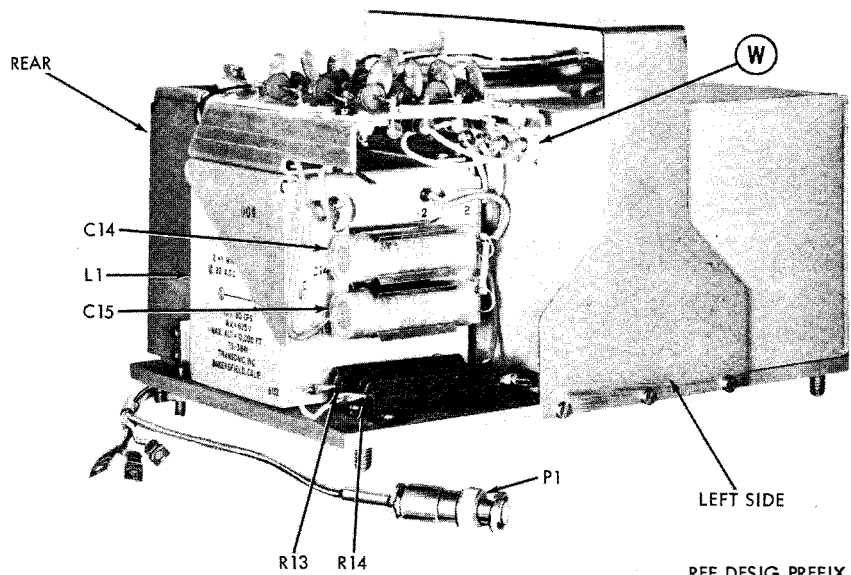
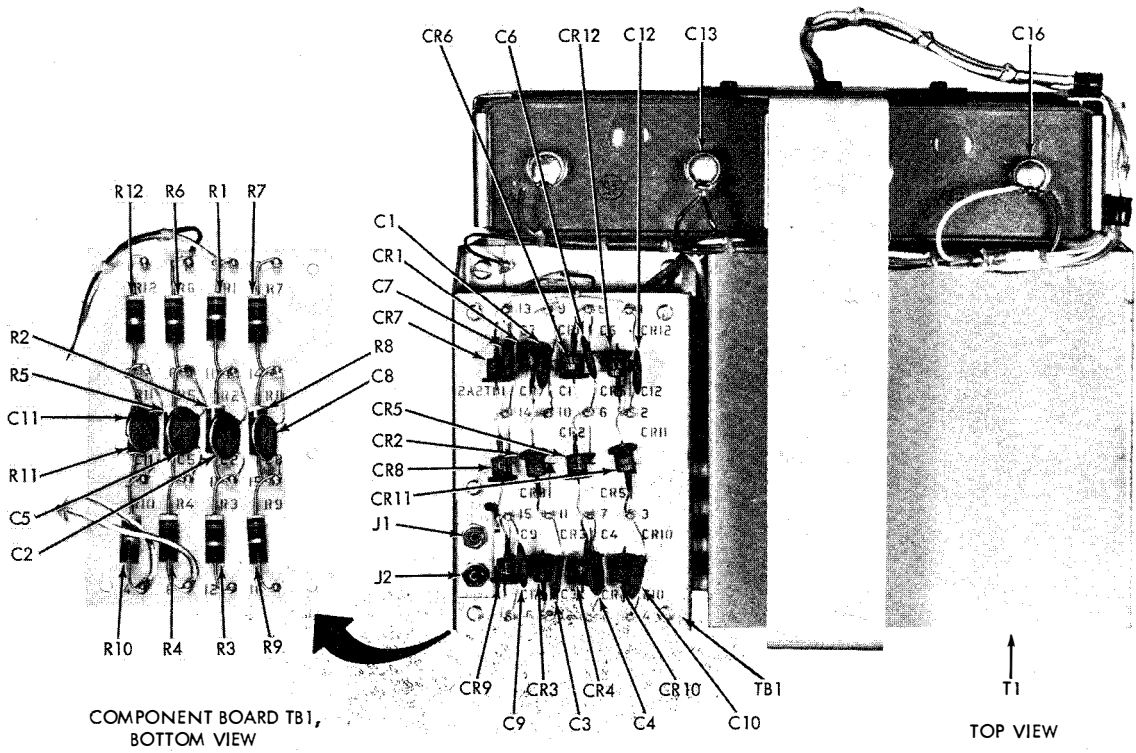

657-27

REF DESIG PREFIX 2A2

Figure 5-5. +950 Volt DC Power Supply, Assembly 2A2, Test Points and Parts Location

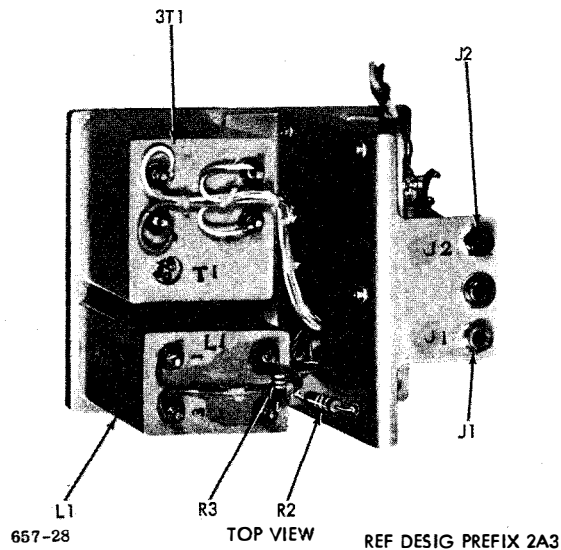
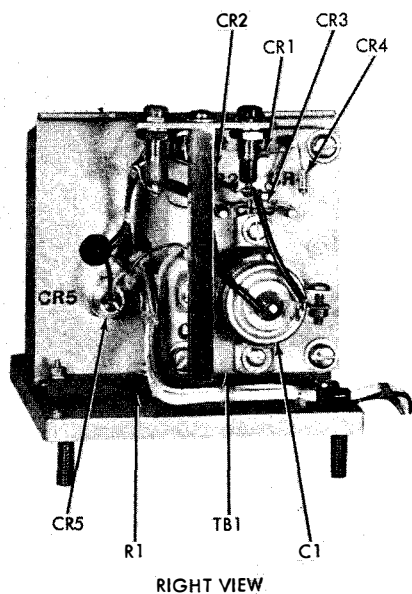

Figure 5-6. Bias Power Supply, Assembly 2A3, Test Points and Parts Location

radio receiver described in table 5-2. This cable (not supplied) should be fabricated from RG-58C/U cable and UG-88C/U connectors.

- Step 14. Set FILAMENT switch 2S7 and LOW VOLTAGE switch 2S6 in ON positions.

- Step 15. Disable interlock switch 1S5, figure 2-5.
- Step 16. Press HIGH VOLTAGE ON switch 2S4.
- Step 17. Set TEST KEY switch 1S4 in locked (up) position.
- Step 18. Turn on radio receiver and allow to warm up.
- Step 19. Tune radio receiver to 23 mc.
- Step 20. Adjust RF DRIVE control on radio frequency amplifier, and rf gain control on radio receiver, for maximum indication on signal strength meter, also located on radio receiver.
- Step 21. Adjust neutralization capacitor 1C71 (figure 5-10, sheet 1) for null indication on signal strength meter.
- Step 22. Increase rf gain and "rock" capacitor 1C71 as necessary to insure that proper null point is reached.
- Step 23. Press HIGH VOLTAGE OFF switch 2S5 and set TEST KEY switch 1S4 in off (center) position.
- Step 24. Set LOW VOLTAGE switch 2S6 and FILAMENT switch 2S7 in OFF positions.
- Step 25. Set MAIN POWER switch 3S1 in OFF position.
- Step 26. Reconnect lead from capacitor 1C78 to terminal board 1TB2-14. Reconnect 3P21 to 1J6.
- Step 27. Install bottom rear cover plate on radio frequency amplifier, slide unit into cabinet and tighten captive screws on front panel. Replace fuse 2F1.

5-4. REPAIR.

a. REMOVAL, REPAIR AND REPLACEMENT OF PARTS, SUBASSEMBLIES, AND UNITS. -- The following paragraphs outline procedures for removal, repair, and replacement of parts, sub-assemblies, and units of Transmitter Group AN/WRA-3 except Radio Frequency Synthesizer O-1115/URC, Unit 5, which is government furnished and described in NAVSHIPS 94829. Prior to proceeding with any of the following procedures, power must be turned off. Place the MAIN POWER switch 3S1, located on the base of the electrical equipment cabinet, in the OFF position.

b. REMOVAL OF PARTS IN RADIO FREQUENCY AMPLIFIER AM-2819/WRA-3. (See figure 5-10, sheets 1 through 5.) -- Parts may be removed from the radio frequency amplifier, when the unit is extended from electrical equipment cabinet, and cover plates are removed. On the top of the unit,

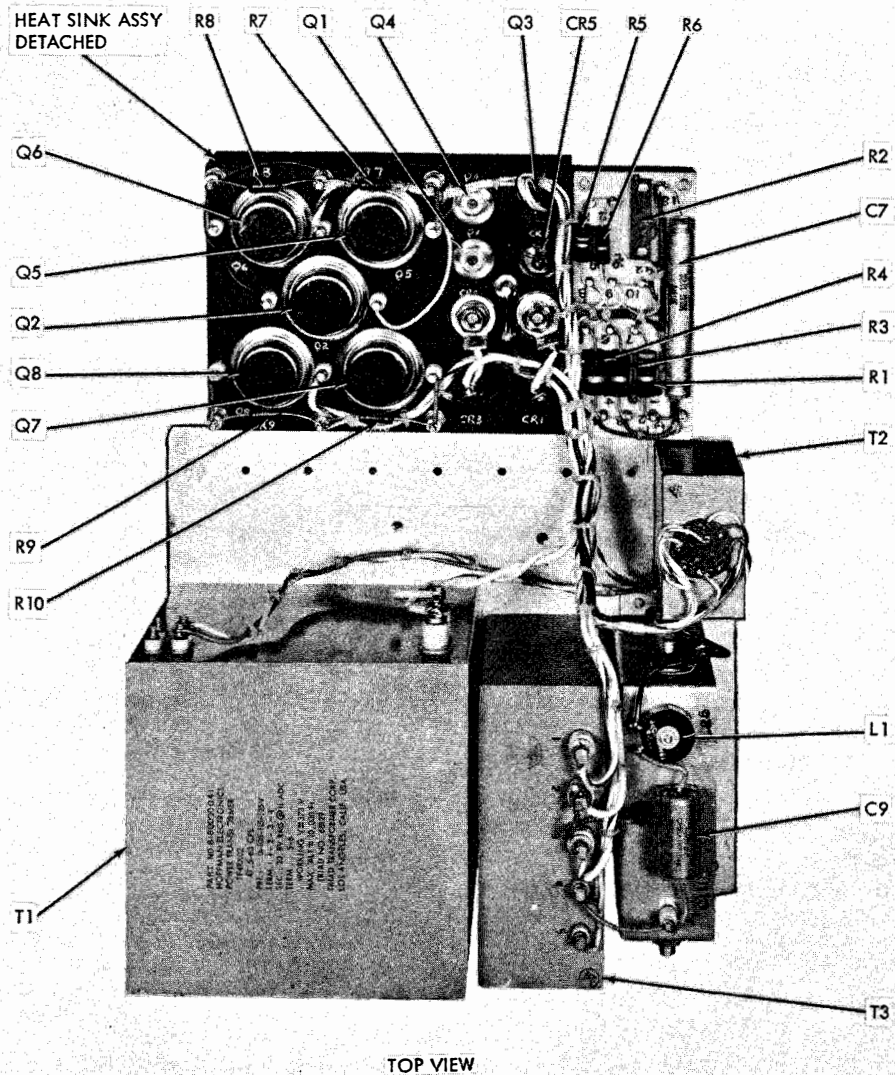

657-29-1

REF DESIG PREFIX 2A4

Figure 5-7. 144 Volt (RMS), 400 cps Power Supply, Assembly 2A4,
Test Points and Parts Location (Sheet 1 of 2)

one plate covers the power amplifier stage. On the bottom of the unit, one plate covers the tuning chassis (balanced modulator and driver amplifier stages), and another plate, designated the bottom radio frequency amplifier cover, covers the blower motor mounting plate and interconnecting terminal boards.

(1) REMOVAL AND REPLACEMENT OF POWER AMPLIFIER TUBE 1V5. (See figure 5-10, sheet 1.)

Step 1. Loosen captive screws on front panel of

radio frequency amplifier, and withdraw unit from cabinet.

Step 2. Remove top plate covering power amplifier stage by loosening captive screws.

Step 3. Ground plate cap of power amplifier tube.

WARNING

PERSONNEL MAY BE INJURED BY HIGH VOLTAGE IF STEP 3 IS NOT ACCOMPLISHED.

ORIGINAL

5-11

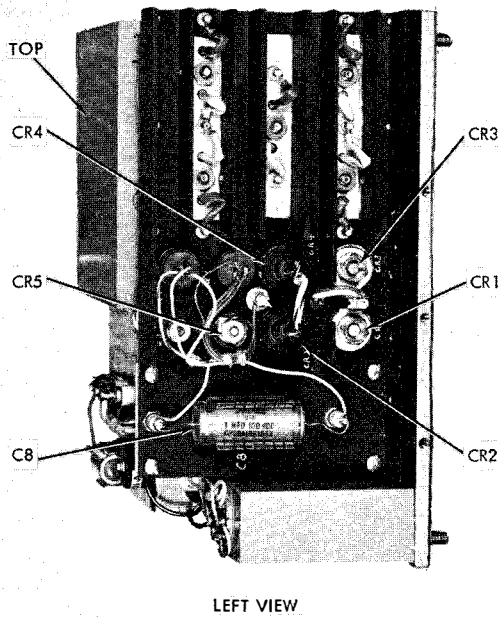

LEFT VIEW

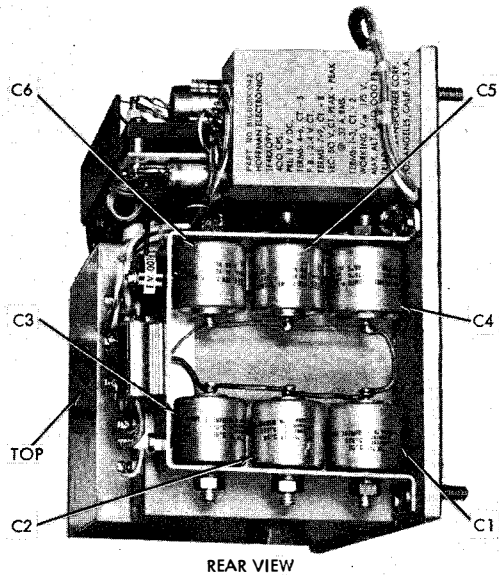

REAR VIEW

657-29-2

REF DESIG PREFIX 2A4

Figure 5-7. 144 Volt (RMS), 400 cps
Power Supply, Assembly 2A4,
Test Points and Parts Location
(Sheet 2 of 2)

- Step 4. Loosen plate cap retaining screw and carefully remove plate cap from 1V5.
- Step 5. Pull up lever on clamp.

- Step 6. Remove power amplifier tube 1V5 by pulling toward rear of unit.
- Step 7. Install new tube by performing, in reverse sequence and procedure, steps 1 through 6, omitting step 3. Check that key on 1V5 is properly oriented when seating tube.

(2) REMOVAL AND REPLACEMENT OF BLOWER MOTOR 1B1. (See figure 5-10, sheet 2.)

- Step 1. Loosen captive screws on front panel of radio frequency amplifier, and withdraw unit from cabinet.
- Step 2. Release tilt locks and position radio frequency amplifier, vertically.
- Step 3. Remove bottom radio frequency amplifier cover, then disconnect, and tag for identification, wires from capacitors 1C100, 1C101, and 1C102. Disconnect electrical connectors attached to blower mounting plate.
- Step 4. Loosen 12 screws on blower mounting plate and pull out mounting plate and blower.
- Step 5. Remove two screws just below 1C101 to remove blower from mounting plate. Remove rubber extrusions from blower.
- Step 6. Install new blower by performing, in reverse sequence and procedure, steps 1 through 5. Blower terminal block must be positioned between two fixed blower clamps during installation.

(3) REMOVAL AND REPLACEMENT OF PARTS IN THE BALANCED MODULATOR AND DRIVER AMPLIFIER STAGES. (See figure 5-10, sheet 5.) -- To gain access to parts of the balanced modulator and driver amplifier stages of the radio frequency amplifier, the tuner bottom cover must be removed when the unit is in the extended and vertical position from electrical equipment cabinet.

(4) REMOVAL OF TUNING CHASSIS. -- Perform the following steps to remove the tuning chassis, which contains the balanced modulator and power amplifier stages.

- Step 1. Loosen captive screws on front panel of radio frequency amplifier, and withdraw unit from electrical equipment cabinet.
- Step 2. Release tilt lock and vertically position radio frequency amplifier.
- Step 3. Remove screws holding tuner bottom cover, gaining access to tuning circuits and driver amplifier tube compartment.

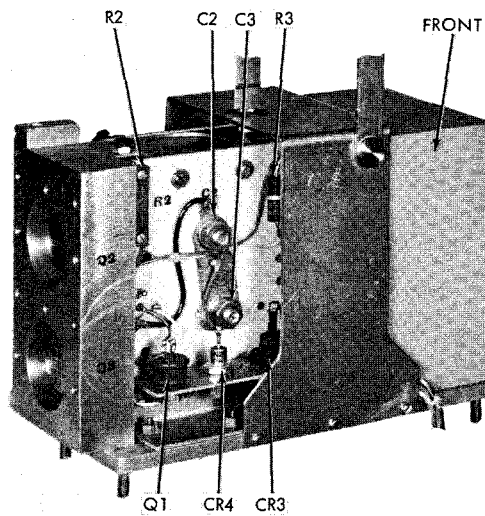
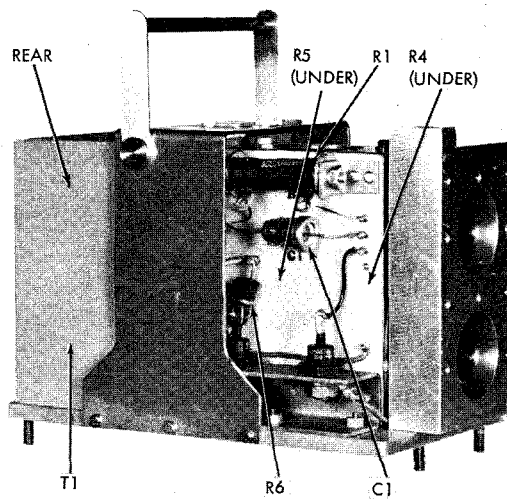
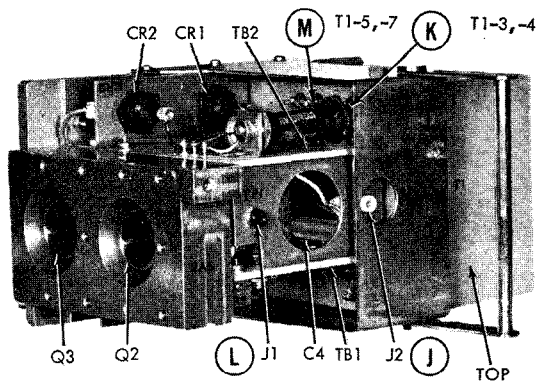

657-30

REF DESIG PREFIX 2A5

Figure 5-8. -28 Volt DC Power Supply,
Assembly 2A5, Test Points and Parts Location

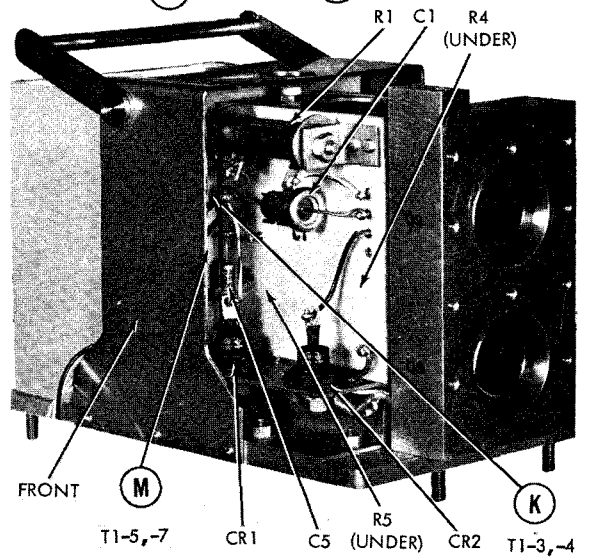
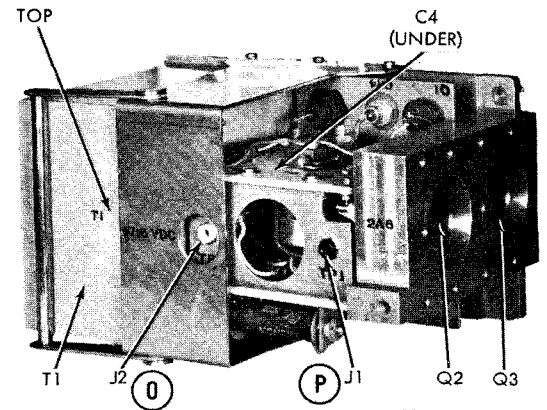

657-31

Q1 CR4 C3 CR3 REF DESIG PREFIX 2A6

Figure 5-9. +28 Volt DC Power Supply,
Assembly 2A6, Test Points and Parts Location

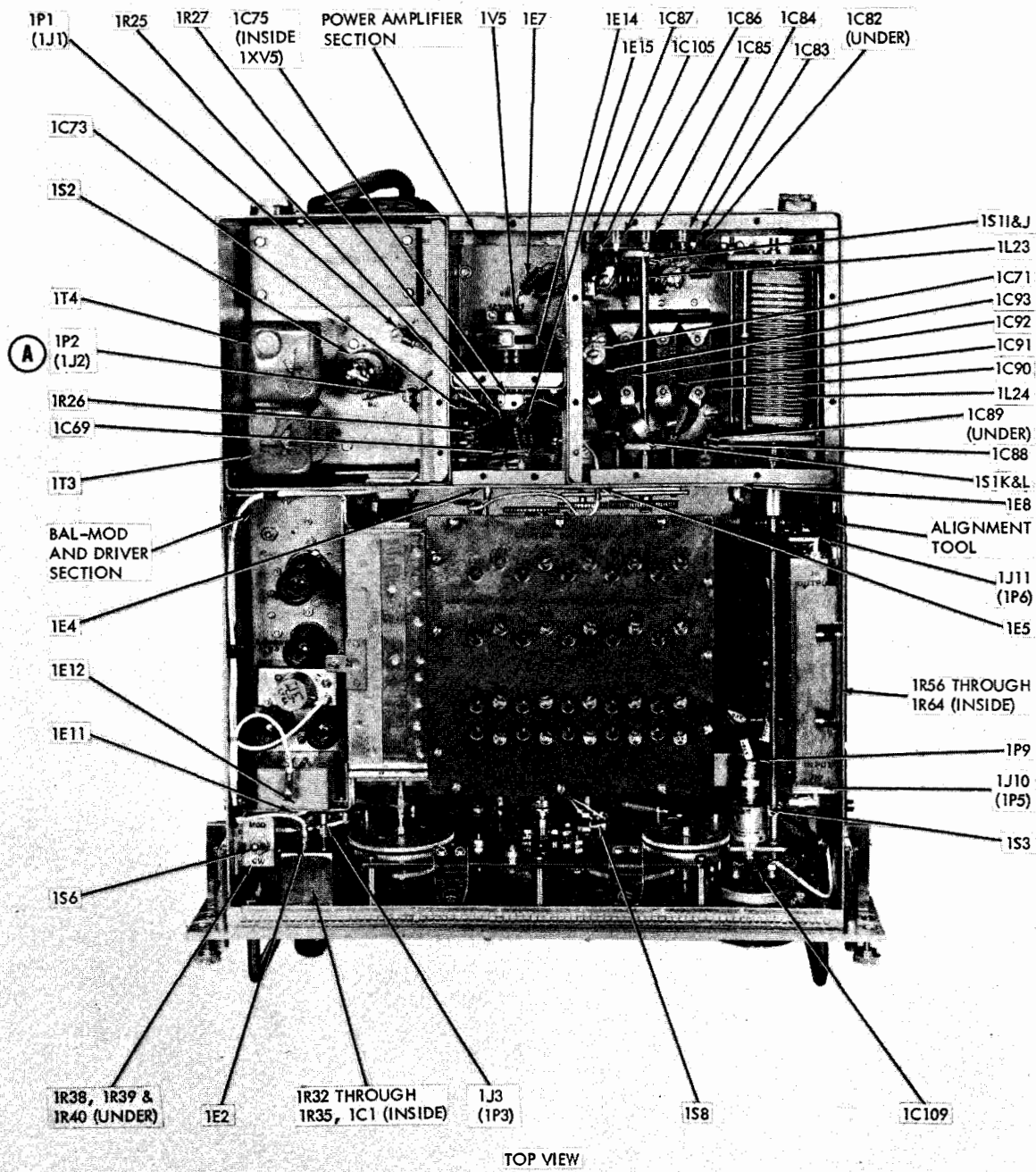

TOP VIEW

657-32-1

Figure 5-10. Radio Frequency Amplifier AM-2819/WRA-3, Unit 1, Test Points and Parts Location (Sheet 1 of 5)

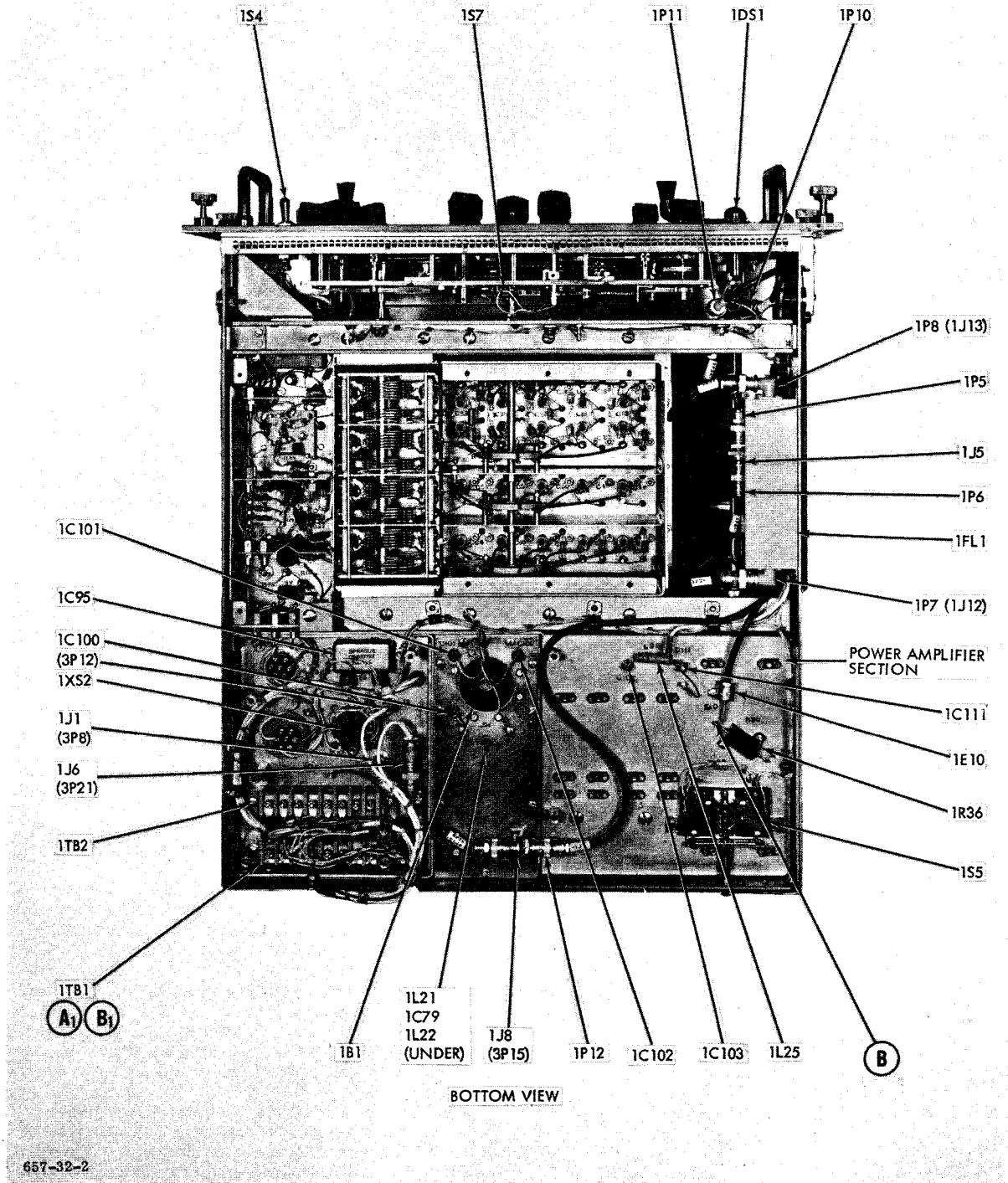
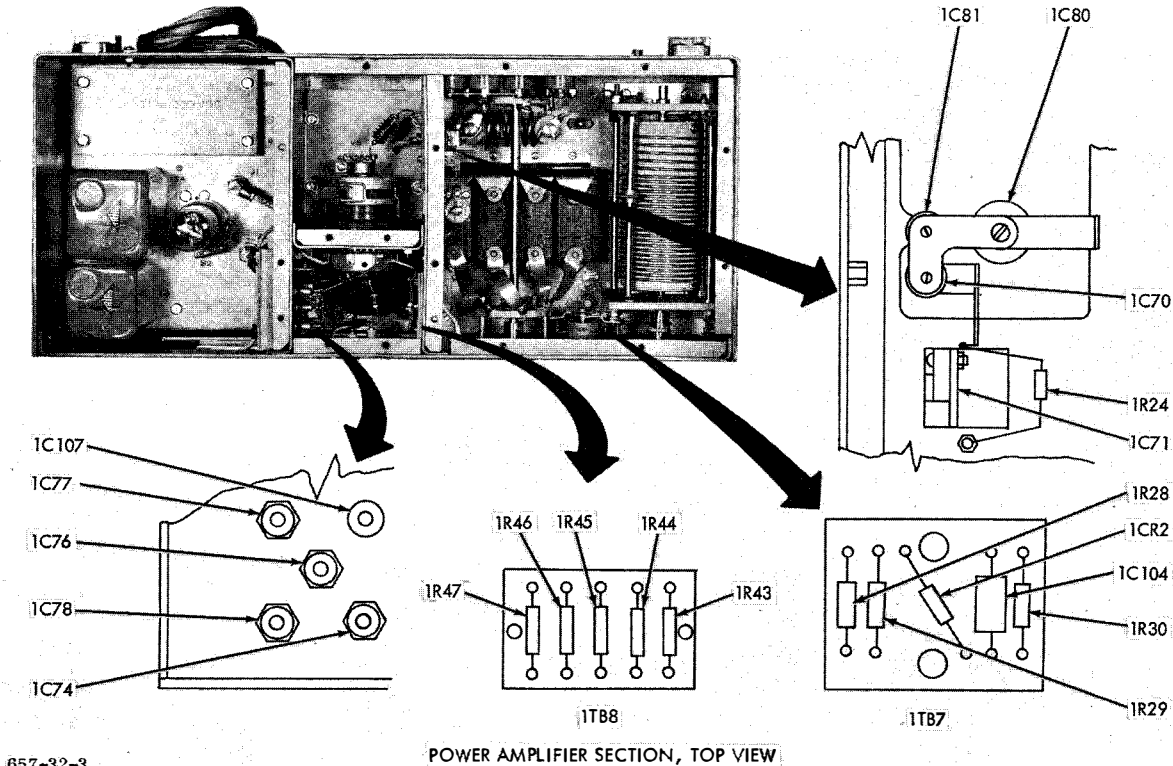

Figure 5-10. Radio Frequency Amplifier AM-2819/WRA-3, Unit 1, Test Points and Parts Location (Sheet 2 of 5)



657-32-3

POWER AMPLIFIER SECTION, TOP VIEW

Figure 5-10. Radio Frequency Amplifier AM-2819/WRA-3, Unit 1, Test Points and Parts Location (Sheet 3 of 5)

- | | |
|--|---|
| <p>Step 4. Disconnect and tag for identification, leads from capacitors 1C96, 1C97, and 1C98.</p> <p>Step 5. Release tilt lock and position radio frequency amplifier in normal (horizontal) position.</p> <p>Step 6. Remove top cover to power amplifier tube 1V5.</p> <p>Step 7. Loosen sleeves 1E4 and 1E5 and unsolder center coaxial leads from capacitors 1C69 and 1C71, and ground leads. Remove entire sleeves and cables from chassis cross member.</p> <p>Step 8. Remove two cable clamps from left side panel of drawer and one cable clamp from chassis cross member.</p> <p>Step 9. Remove plug 1P1 from jack 1J1.</p> <p>Step 10. Remove plug 1P4 from jack 1J9 or jack 1J7.</p> <p>Step 11. Rotate BAND SELECTOR switch to a position where roll pin is accessible on front side of band selector coupling.</p> | <p>Step 12. Remove roll pin and rotate BAND SELECTOR switch to 2-4 MC position.</p> <p>Step 13. Loosen setscrew on same half of band selector coupling.</p> <p>Step 14. Slide front half of coupling with nylon bushing toward front panel.</p> <p>Step 15. Rotate DRIVER TUNING switch until roll pin on rear half of driver tuning coupling is accessible.</p> <p>Step 16. Remove roll pin from coupling, then rotate DRIVER TUNING switch completely clockwise.</p> <p>Step 17. Loosen setscrew on same half of driver tuning coupling.</p> <p>Step 18. Slide rear half of coupling with nylon bushing toward tuner chassis.</p> <p>Step 19. Loosen two hex head screws on idler plate between tuner chassis and cross member, and rotate idler plate upwards to disengage gears. Slightly tighten one screw to hold idler plate in disengaged position.</p> |
|--|---|

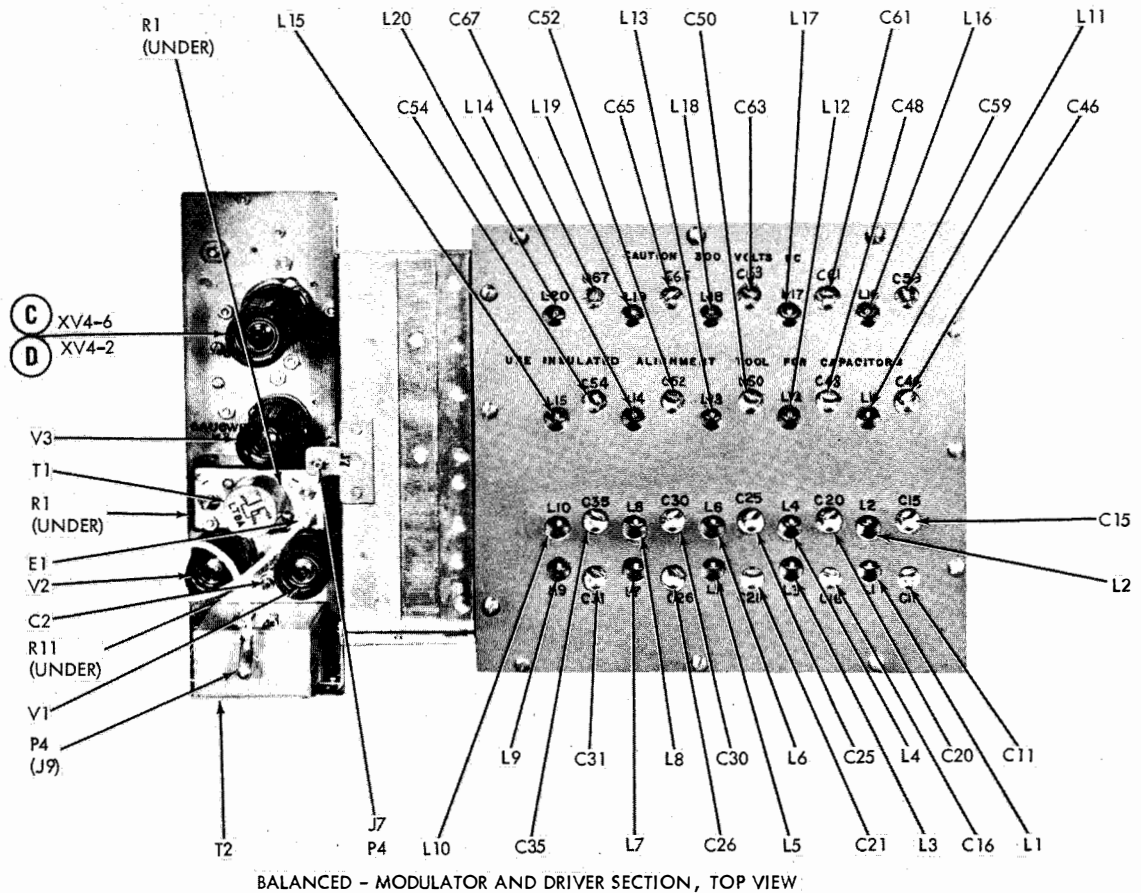

657-32-4

REF DESIG PREFIX 1

Figure 5-10. Radio Frequency Amplifier AM-2819/WRA-3, Unit 1,
Test Points and Parts Location (Sheet 4 of 5)

- Step 20. Release tilt lock and position radio frequency amplifier vertically. Remove screws holding tuner chassis from supporting flange and channel.

CAUTION

Tuner chassis must be held in place while removing screws.

- Step 21. Release tilt lock and position radio frequency amplifier in normal (horizontal) position.
- Step 22. Lift tuner assembly out of radio frequency amplifier, being careful to avoid damaging feedthrough capacitors 1C96, 1C97, and 1C98.

(5) INSTALLATION OF TUNING CHASSIS. -- Perform the following steps to replace the tuning chassis in the radio frequency amplifier, which must be extended from the electrical equipment cabinet, and in a horizontal position before proceeding.

- Step 1. Set BAND SELECTOR switch in 2-4 MC position.
- Step 2. Rotate DRIVER TUNING control fully clockwise.
- Step 3. Check to insure that nylon bushing is still on band selector shaft coupler.
- Step 4. Drive shafts of BAND SELECTOR switch and DRIVER TUNING switch must be in proper position before tuning chassis is installed. Check to insure that small

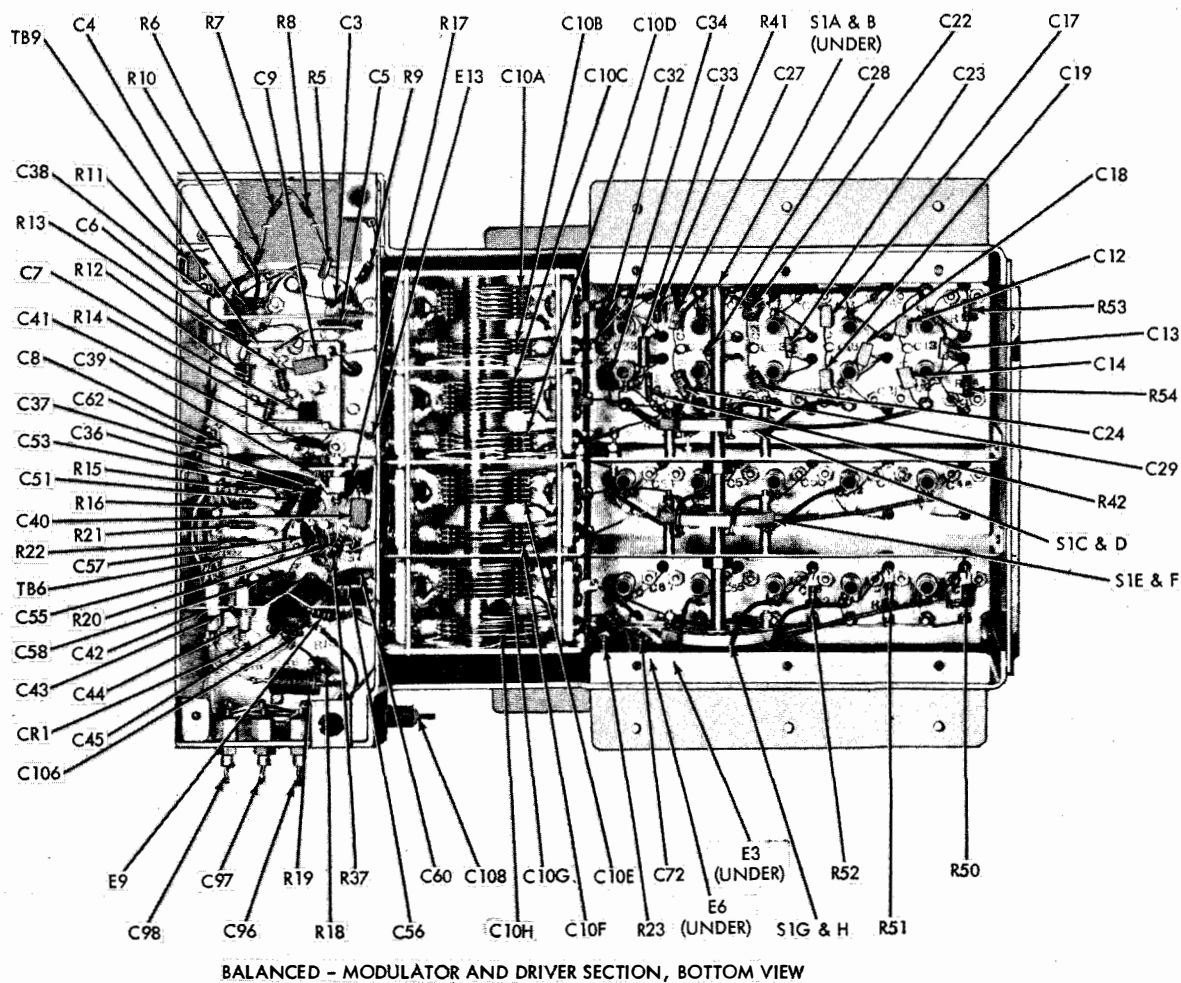

BALANCED - MODULATOR AND DRIVER SECTION, BOTTOM VIEW

657-32-5

REF DESIG PREFIX 1

Figure 5-10. Radio Frequency Amplifier AM-2819/WRA-3, Unit 1,
Test Points and Parts Location (Sheet 5 of 5)

wiper on 1S1B is making contact with inductor 1L1, and front wiper is between contacts to capacitors 1C92 and 1C93. Rotate shafts to these positions, if required.

- Step 5. Rotate tuning capacitor fully clockwise.
- Step 6. Check to insure that nylon bushing and tuning capacitor coupling is still on shaft of tuning capacitor.
- Step 7. Set tuning chassis into radio frequency amplifier, being careful to avoid damag-

ing feedthrough capacitors 1C96, 1C97, and 1C98.

- Step 8. Release tilt lock on front panel, and rotate radio frequency amplifier, vertically, holding tuning capacitor in place. Install mounting screws in the supporting flange and channel while still holding the tuning capacitor in place. Do not tighten the mounting screws completely.
- Step 9. Position tuning capacitor so that shaft aligns with front panel shaft, then tighten three mounting screws.

- Step 10. Position tuner chassis to align switch shaft with front panel shaft, then tighten mounting screws.
- Step 11. Slide front half of bandswitch coupling, with nylon bushing, to engage mating half of coupling. When pin hole in coupling aligns with pin hole in shaft, tighten setscrew, then rotate BAND SELECTOR switch until pin hole is accessible, and press in pin.
- Step 12. Slide rear half of capacitor coupling, with nylon bushing, to engage mating half of coupling, then rotate DRIVER TUNING control until pin hole in coupling aligns with pin hole in shaft, then tighten setscrew. Rotate DRIVER TUNING control until pin hole is accessible, then press in pin.

NOTE

If a new tuning capacitor has been installed, a roll pin hole must be drilled in the capacitor shaft. To accomplish this, first adjust the tuning capacitor so that when the DRIVER TUNING control is rotated to extreme ends, the rotor blades do not seat, then rotate the DRIVER TUNING control until the pin hole in the coupling is accessible for drilling. Drill a 0.062 in. diameter hole in the shaft, using the existing coupling hole as a guide. Press in the roll pin after the hole is drilled.

- Step 13. Check to insure that BAND SELECTOR switch is in 2-4 MC position, and switch in tuner chassis is correspondingly in same position. Also check to insure that drive shaft for BAND SELECTOR switch is still in same position. (See step 4.)
- Step 14. Loosen two hex head screws on idler gear plate and rotate idler gear plate down to engage with tuner chassis gear, then tighten both hex head screws.
- Step 15. Reverse steps 3 through 10 to make nec-

essary electrical connections and install covers.

- Step 16. Realign radio frequency amplifier, as described in paragraph 5-3d(2).

c. REMOVAL OF PARTS IN POWER SUPPLY PP-2796/WRA-3. (See figures 5-1 and 5-3, sheets 1 through 3.) -- Assemblies and parts of the power supply may be removed when the unit is extended from the electrical equipment cabinet, and cover plates are removed. To remove any assembly from the chassis, first remove the nuts which hold the assembly in place on the bottom of the unit, then lift the assembly out by using the handles provided. After the assembly has completely cleared the chassis, the wires from the assembly may be disconnected at the terminal boards on the chassis. Electrical disconnection is normally not required to troubleshoot or repair any assembly, however.

d. REMOVAL OF PARTS IN ELECTRICAL EQUIPMENT CABINET CY-3022/WRA-3. (See figure 5-11.) -- Parts installed on the rear vertical panel of the unit may be removed after the unit located in front of that area is first removed. Most parts located in the blower area must be removed through the area normally occupied by the power supply. By removing the front panel in the blower area, air filters 1MP1 and 1MP2 may be removed. If wiring relating to MAIN POWER switch 3S1 and MAIN POWER fuses 3F1 and 3F2 must be checked, an internal switch panel must also be removed.

WARNING

PRIMARY POWER MUST BE REMOVED FROM THE TRANSMITTER GROUP BEFORE ANY REMOVAL IS ACCOMPLISHED IN THE BLOWER AREA. FAILURE TO ACCOMPLISH THIS MAY RESULT IN SERIOUS INJURY TO PERSONNEL.

e. REMOVAL OF PARTS IN INTERCONNECTING UNIT MX-3645/WRA-3. (See figure 5-12.) -- All parts of the interconnecting unit are visible from the top and may be removed when the unit is extended from the electrical equipment cabinet.

NOTE:
PLUGS NOT SHOWN ARE LOCATED ON
CABLE HARNESS TO UNITS, AS
FOLLOWS:
UNIT 1: 3P8, 3P12, 3P15, 3P21
UNIT 2: 3P20
UNIT 4: 3P5, 3P19
UNIT 5: 3P9, 3P16, 3P22

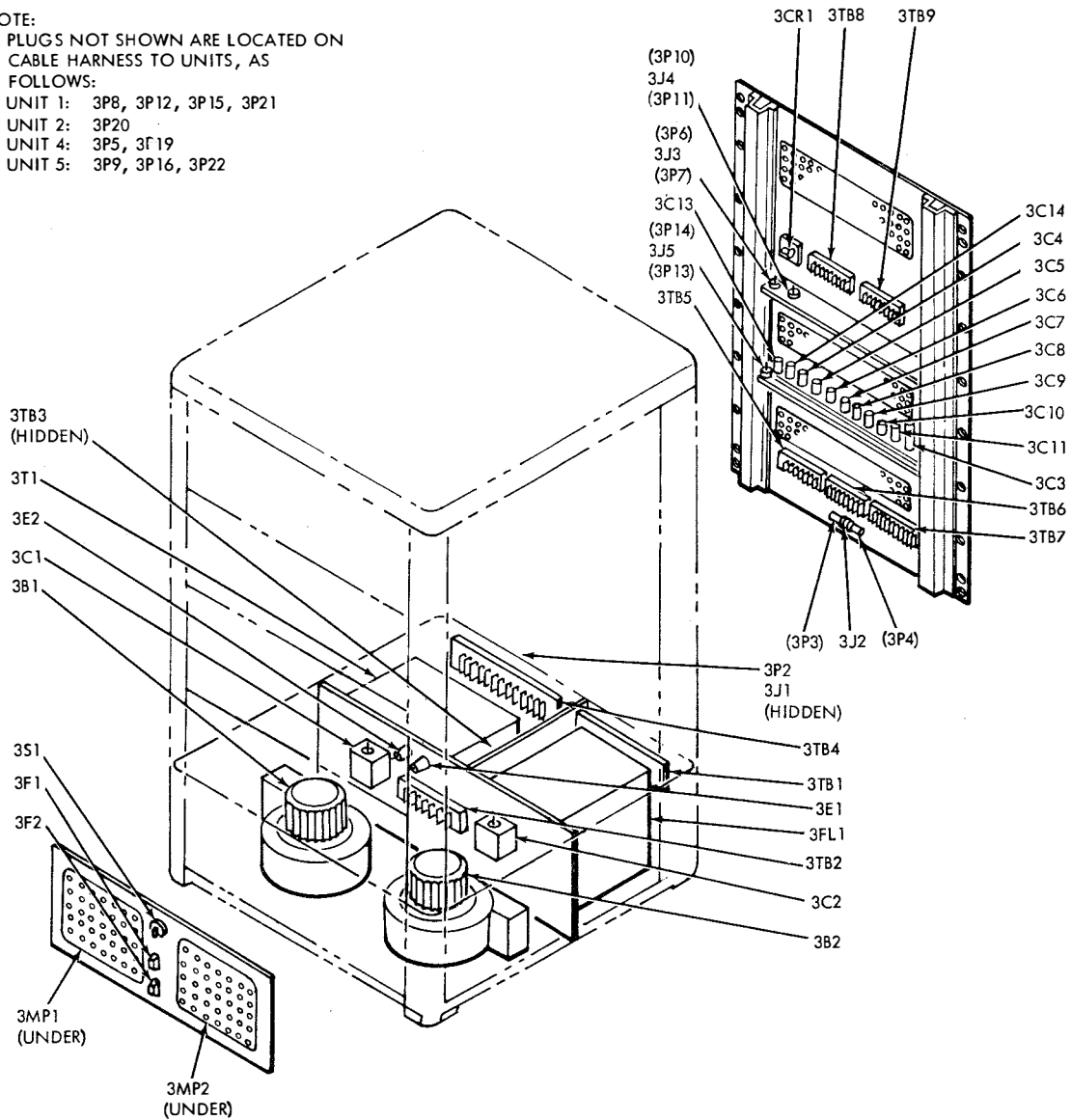

657-33

Figure 5-11. Electrical Equipment Cabinet CY-3022/WRA-3, Unit 3,
Test Points and Parts Location

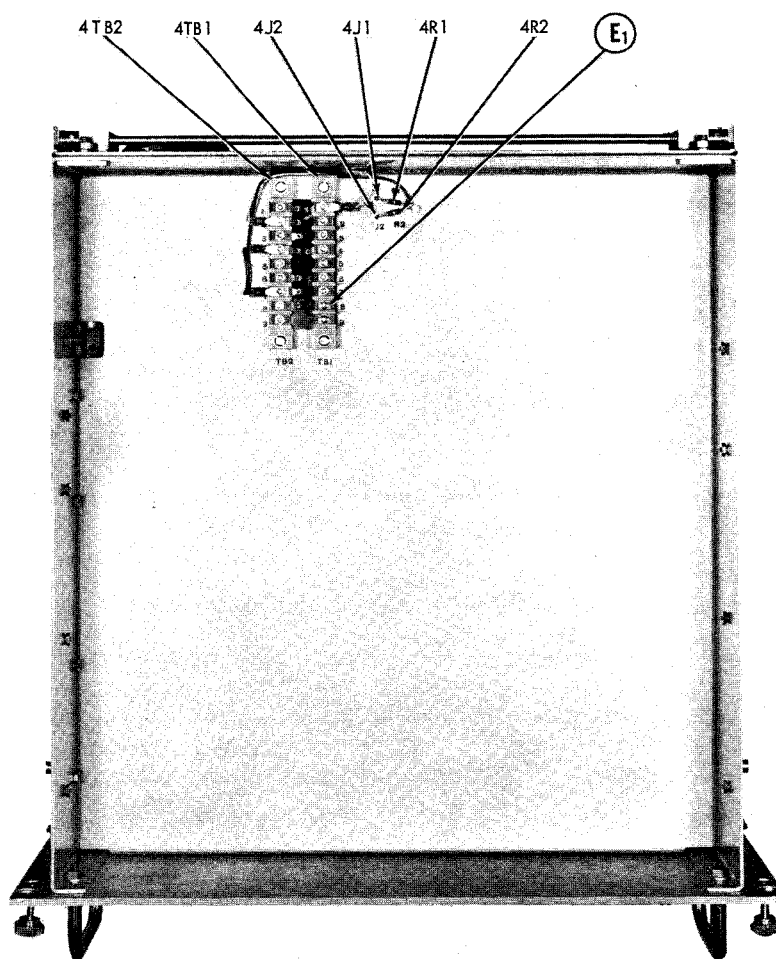

657-34

Figure 5-12. Interconnecting Unit MX-3645/WRA-3, Unit 4,
Test Points and Parts Location

ORIGINAL

5-21

TABLE 5-1. TRANSMITTER GROUP AN/WRA-3, INITIAL CONTROL SETTINGS FOR MAINTENANCE

FRONT PANEL CONTROL	REFERENCE DESIGNATION	POSITION
ELECTRICAL FREQUENCY SYNTHESIZER O-1115/URC		
POWER	5S1	OFF
BANDSWITCH		2-4 mc
RADIO FREQUENCY AMPLIFIER AM-2819/WRA-3		
BAND SELECTOR	1S1	2-4
TEST KEY	1S4	Off (center position)
TUNE OPERATE	1S3	OPERATE
RF DRIVE	1R33	0
POWER SUPPLY PP-2796/WRA-3		
FILAMENT	2S7	OFF
LOW VOLTAGE	2S6	OFF
ELECTRICAL EQUIPMENT CABINET CY-3022/WRA-3		
MAIN POWER	3S1	OFF

TABLE 5-2. TRANSMITTER GROUP AN/WRA-3, TEST EQUIPMENT REQUIRED FOR MAINTENANCE

TEST EQUIPMENT	APPLICATION
Multimeter AN/PSM-4	Measurement of output voltages during adjustment of power supply, unit 2.
Oscilloscope AN/USM-117	Display of proper Lissajous pattern during frequency adjustment of power supply, unit 2.
Dummy Load DA-91/U	Termination of rf output throughout tuning and adjustment procedures.
RF Signal Generator CAQI-606-A	Signal input for driver amplifier and balanced modulator alignment.
Radio receiver capable of reception at 23 megacycles, and containing a signal strength meter.	Measures rf output for amplifier neutralization.

TABLE 5-3. RADIO FREQUENCY AMPLIFIER AM-2819/WRA-3, CONTROL SETTINGS AND ADJUSTMENTS FOR DRIVER AMPLIFIER ALIGNMENT

OUTPUT FREQUENCY	CONTROL SETTINGS				ADJUST
	BAND SELECTOR (MC)	DRIVER AND PA TUNING (MC)	SYNTHESIZER TUNING (MC)	SIGNAL GENERATOR TUNING (MC)	
2	2-4	2	2.5	0.5	L16, L11, L2, L1
4	2-4	4	4.5	0.5	C59, C46, C15, C11
4	4-8	4	3.5	0.5	L17, L12, L4, L3
8	4-8	8	7.5	0.5	C61, C48, C20, C16
8	8-16	8	9.5	1.5	L18, L13, L6, L5
16	8-16	16	17.5	1.5	C63, C50, C25, C21
16	16-23	16	18.5	2.5	L19, L14, L8, L7
23	16-23	23	25.5	2.5	C65, C52, C30, C26
23	23-32	23	19.5	3.5	L20, L15, L10, L9
32	23-32	32	28.5	3.5	C67, C54, C35, C31



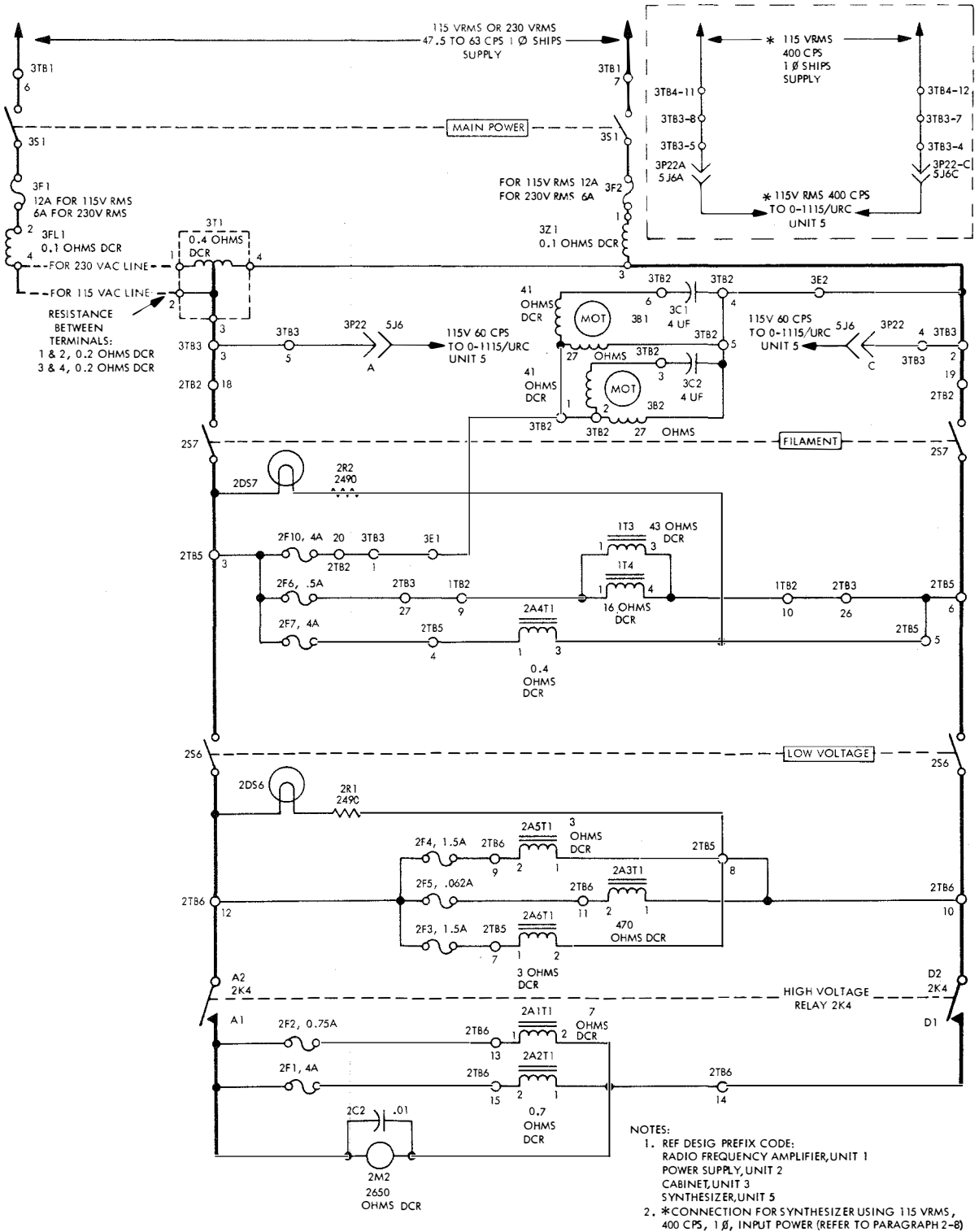

657-35

Figure 5-13. Transmitter Group AN/WRA-3,
Primary Power Distribution

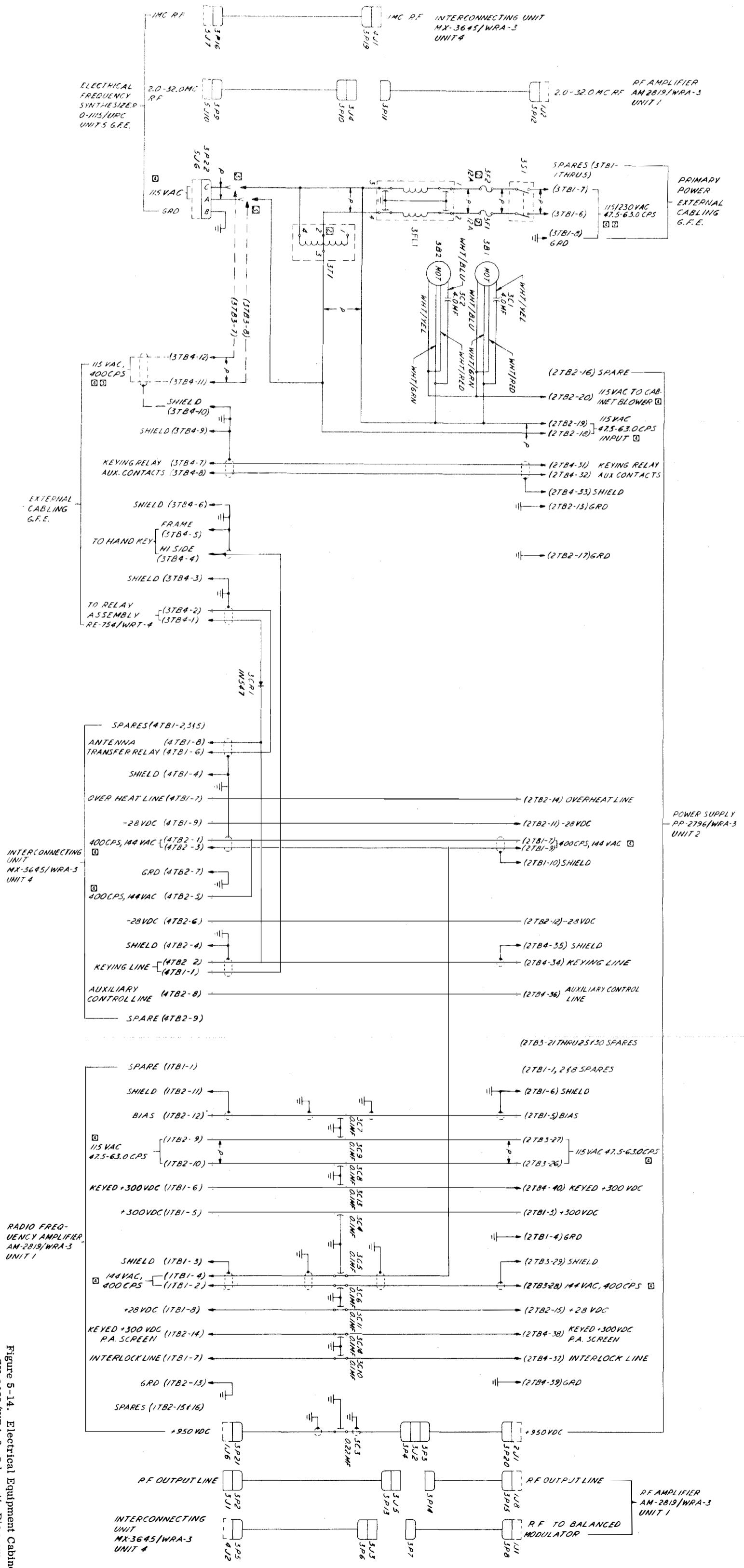

1. REF. DESIG. PREFIX CODE: 1 RADIO FREQUENCY AMPLIFIER, 2 POWER SUPPLY, 3 ELECTRICAL EQUIPMENT CABINET, 4 INTERCONNECTING UNIT, AND 5 ELECTRICAL FREQUENCY SYNTHESIZER.
2. FOR ZNY OPERATION, WIRE IS MOVED FROM 31-2 TO 31-1 AND 31 AND 32 ARE CHANGED FROM 12A TO 9A.
3. DOTTED LINES INDICATE WIRING FOR EMERGENCY SUBSTITUTION OF A 115 VAC 60 CPS SYNTHESIZER.
4. SINGLE PHASE POWER.

657-82

ORIGINAL

Figure 5-14. Electrical Equipment Cabinet
CY-3022/WRA-3, Schematic Diagram

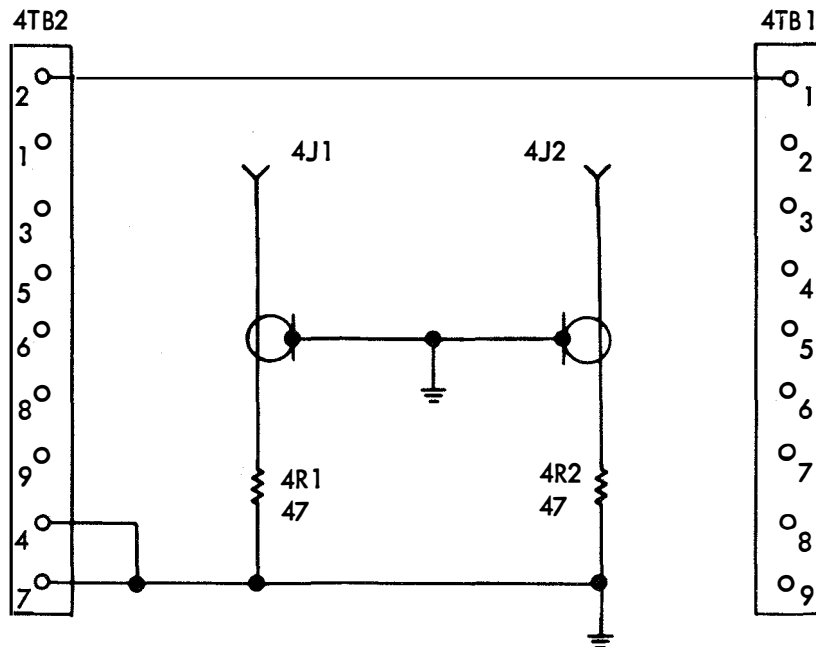

NOTE:
UNLESS OTHERWISE SPECIFIED
1. ALL RESISTORS IN OHMS, 1/2W, $\pm 10\%$ TOL.

PART LOCATION INDEX

REF DESIG	LOC	REF DESIG	LOC	REF DESIG	LOC	REF DESIG	LOC	REF DESIG	LOC	REF DESIG	LOC
B1	15I	C38	11H	C83	18C	J11	23C	R5	7G	R49	*
C1	5E	C39	12E	C84	18C	J12	24C	R6	7G	R50	15A
C2	8G	C40	12E	C85	16B	J19	24C	R7	7G	R51	15B
C3	9G	C41	12I	C86	16B	L1	8A	R8	7G	R52	15B
C4	9G	C42	13H	C87	17B	L2	8A	R9	8G	R53	7A
C5	9G	C43	16H	C88	19B	L3	8B	R10	8G	R54	9A
C6	9G	C44	13F	C89	19B	L4	8B	R11	8G	R55	*
C7	9I	C45	14G	C90	16A	L5	8B	R12	9H	R56	20C
C8	12H	C46	11A	C91	16A	L6	8B	R13	9H	R57	21C
C9	7E	C47	*	C92	17A	L7	8C	R14	11E	R58	21C
C10-A	8E	C48	11A	C93	17A	L8	8C	R15	12F	R59	21C
C10-B	8E	C49	*	C94	*	L9	8C	R16	13G	R60	21C
C10-C	10E	C50	11B	C95	16I	L10	8C	R17	12E	R61	22C
C10-D	10E	C51	12F	C96	16H	L11	12B	R18	13G	R62	22C
C10-E	11D	C52	11C	C97	20H	L12	12B	R19	16G	R63	22C
C10-F	11D	C53	13G	C98	20H	L13	12C	R20	14F	R64	22C
C10-G	15D	C54	11C	C99	*	L14	12C	R21	15F	S1-A	8E
C10-H	15D	C55	15F	C100	16H	L15	12D	R22	16G	S1-B	6B
C11	7A	C56	15F	C101	16H	L16	16A	R23	14E	S1-D	10B
C12	8A	C57	16F	C102	16I	L17	16B	R24	17C	S1-E	11D
C13	8A	C58	16F	C103	22B	L18	16B	R25	17E	S1-F	11B
C14	8A	C59	15A	C104	21B	L19	16C	R26	17F	S1-G	15D
C15	9A	C60	14F	C105	17B	L20	16C	R27	18F	S1-H	14B
C16	7B	C61	15B	C106	14I	L21	19F	R28	20A	S1-I	17B
C17	7B	C62	12H	C107	17F	L22	19F	R29	21B	S1-K	17A
C18	8A	C63	15B	C108	14F	L23	18C	R30	22A	S1-L	17A
C19	8B	C64	*	C109	24B	L24	18B	R31	*	S2	19I
C20	9B	C65	15C	C110	*	L25	23B	R32	*	S3	25E
C21	7B	C66	*	C111	23B	M1	24B	R33A	4E	S4	17H
C22	7B	C67	15C	CR1	16G	P1	3F	R33B	4E	S5	1H
C23	8B	C68	*	CR2	21B	P2	1C	R34	4E	S6	2D
C24	*C	C69	17D	DS1	18I	P3	3D	R35	4E	S7	19H
C25	9C	C70	17C	DS2	21F	P4	6F	R36	24F	S8	18H
C26	7C	C71	17C	DS3	21G	P5	20C	R37	14E	T1	4G
C27	7C	C72	17D	FL1	24C	P6	23C	R38	2E	T2	7F
C28	8B	C73	17F	J1	3F	P7	23C	R39	1E	T3	21G
C29	8C	C74	17G	J2	1C	P8	24C	R40	2E	T4	21H
C30	9C	C75	18F	J3	3D	P9	25E	R41	7C	TB1	17H
C31	7C	C76	20H	J4	*D	P10	24E	R42	9D	TB2	21I
C32	7C	C77	20H	J5	21D	P11	25E	R43	20E	V1	8F
C33	8C	C78	18F	J6	23H	P12	25E	R44	20E	V2	8G
C34	8D	C79	19F	J7	10E	R1	5G	R45	21E	V3	12E
C35	9D	C80	18D	J8	25E	R2	*	R46	21E	V4	15F
C36	12F	C81	19D	J9	6F	R3	*	R47	22E	V5	17E
C37	13F	C82	17B	J10	20C	R4	*	R48	*		

*Not used

RESISTANCE CHART

TUBE	PIN NUMBER									CENTER PIN
	1	2	3	4	5	6	7	8	9	
V1	210	840*	0.2	0	4 mego	4 mego	0.5	--	--	--
V2	210	620*	0.2	0	4 mego	4 mego	0.5	--	--	--
V3	0	0	0.2	0	4 mego	4 mego	100	--	--	--
V4	82	37	4 mego	0	0.2	4 mego	0	4 mego	37	--
V5	24K	0	0.1	0	NC	0	0.1	0	INF	INF**

- NOTES**
- Measurements taken with multimeter.
 - All measurements taken with respect to ground.
 - Power supply cables disconnected.
 - *Varies with setting of R11.
 - **Varies with setting of 2A3R1.
 - K = 1,000; mego = 1,000,000.
 - CRI forward resistance = 8.5 ohms, reverse resistance = 4 mego.

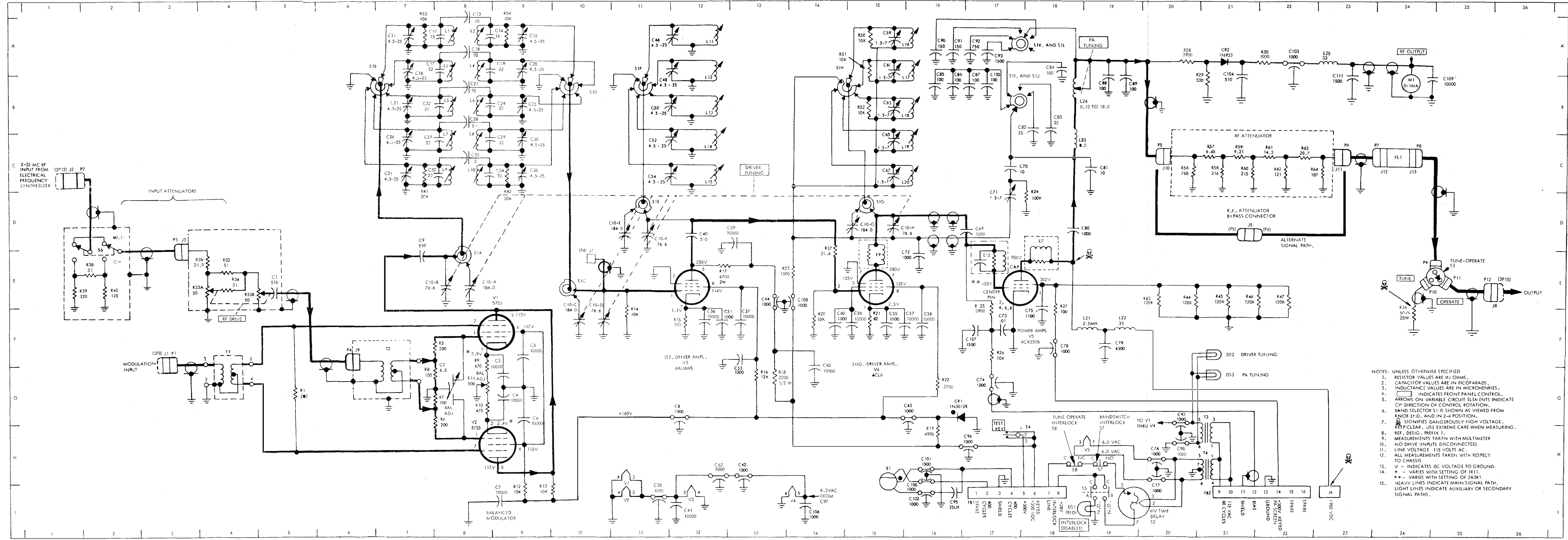

- NOTES**
- UNLESS OTHERWISE SPECIFIED RESISTOR VALUES ARE IN OHMS.
 - CAPACITOR VALUES ARE IN PICOFARADS.
 - INDUCTANCE VALUES ARE IN MICROHENRIES.
 - INDICATES FRONT PANEL CONTROL.
 - ARROWS ON VARIABLE CIRCUIT ELEMENTS INDICATE CW DIRECTION OF CONTROL ROTATION.
 - BAND SELECTOR S1 IS SHOWN AS VIEWED FROM KNOB END, AND IN 2-4 POSITION.
 - ⚡ SIGNIFIES DANGEROUSLY HIGH VOLTAGE. KEEP CLEAR. USE EXTREME CARE WHEN MEASURING.
 - REF. DESIG. PREFIX I.
 - MEASUREMENTS TAKEN WITH MULTIMETER. NO DRIVE INPUTS DISCONNECTED.
 - LINE VOLTAGE 115 VOLTS AC.
 - ALL MEASUREMENTS TAKEN WITH RESPECT TO CHASSIS.
 - V - INDICATES DC VOLTAGE TO GROUND.
 - * - VARIES WITH SETTING OF R11.
 - ** - VARIES WITH SETTING OF 2A3R1.
 - HEAVY LINES INDICATE MAIN SIGNAL PATH. LIGHT LINES INDICATE AUXILIARY OR SECONDARY SIGNAL PATHS.

Figure 5-16. Radio Frequency Amplifier AM-2819/WRA-3, Unit 2, Schematic Diagram

PART LOCATION INDEX

REF DESIG	LOC	REF DESIG	LOC	REF DESIG	LOC	REF DESIG	LOC	REF DESIG	LOC
UNIT 2									
B1	25B	S1	20H	C15	23D	J1	11D	T2	18B
C1	25F	S2	25I	C16	23D	J2	10E	T3	22A
C2	18D	S4	19H	CR1	21C	R1	11D		
C3	*	S5	16H	CR3	21C	R2	12D	UNIT 2A5	
C4	26B	S6	5C	CR4	21C	R3	11D	C1	9G
C5	24H	S7	2C	CR5	21D	T1	9D	C2	10F
C6	22H			CR6	21E			C3	10F
CR1	23E	UNIT 2A1		CR7	20D	UNIT 2A4		C4	11F
CR2	23E	C1	20F	CR8	20D	C1	10B	CR1	9F
DS1	18H	C2	21F	CR9	20D	C2	10B	CR2	9F
DS2	21G	C3	21F	CR10	19C	C3	11B	CR3	10F
DS3	25G	CR1	19F	CR11	19C	C4	11B	J1	10E
DS4	15G	CR2	19F	CR12	20C	C5	11B	J2	11F
DS5	15G	CR3	19F	T1	18C	C6	12B	Q1	12F
DS6	15G	CR4	19F	C7	13B	Q2	12F	Q2	12F
DS7	6C	CR5	22F	C8	19B	Q3	13B	Q3	13F
DS8	26I	CR6	22F	J1	22C	C9	23B	R1	10G
F1	16D	J1	20E	L1	23C	CR2	9B	R2	11G
F2	16E	J2	21E	P1	25C	CR3	9B	R3	11G
F3	8H	L1	21F	R1	21C	CR4	9B	R4	12G
F4	8F	R1	19F	R2	21C	CR5	12B		
F5	9C	R2	22F	R3	21D	L1	23B	UNIT 2A6	
F6	4A	R3	22F	R4	21D	Q1	13B	C1	9I
F8	24B	R4	22F	R5	21D	Q2	13B	C2	10H
F9	25A	T1	18F	R6	21E	Q3	15B	C3	10I
F10	4B			R7	20E	Q4	15B	C4	13I
J1	25B	UNIT 2A2		R8	20D	Q5	20A	CR1	9I
K1	24H	C1	21C	R9	19D	Q6	21A	CR2	9I
K2	22I	C2	21D	R10	19C	Q7	20B	CR3	9H
K3	17I	C3	21D	R11	19C	Q8	21B	CR4	10I
K4	16I	C4	21D	R12	20C	R1	12B	J1	10H
L1	22G	C5	21D	R13	24C	R2	13B	J2	11H
M1	24F	C6	21D	R14	24D	R3	14A	Q1	12I
M2	16C	C7	20D	R4	14B	Q2	14B	Q2	12I
R1	9D	C8	20D	R5	17B	Q3	17B	Q3	13H
R2	9C	C9	20D	C1	10D	R6	16B	R1	10I
R3	17H	C10	20D	CR1	9D	R7	19B	R2	11I
R4	17H	C11	20C	CR2	9D	R8	19B	R3	12I
R5	24H	C12	20C	CR3	9D	R9	19B	R4	11I
R6	22G	C13	22D	CR4	9D	R10	19B	R5	13I
R7	22G	C14	23C	CR5	11D	T1	9B	T1	9H

TRANSISTOR VOLTAGE CHART

TRANSISTOR	EMITTER	BASE	COLLECTOR
144 VOLT (RMS) 400 CPS POWER SUPPLY (2A4)			
Q1	6.6	6.4	0
Q2	8.2	8.4	0
Q3	27	27.7	8.4
Q4	27	8.3	8.4
Q5	26.8	27.3	0
Q6	26.8	27.3	0
Q7	26.8	27.3	0
Q8	26.8	27.3	0
-28 VOLT DC POWER SUPPLY (2A5)			
Q1	-27.6	-27.9	-35.3
Q2	-28	-27.9	-35.3
Q3	-28	-27.9	-35.3
+28 VOLT DC POWER SUPPLY (2A6)			
Q1	-28.2	-28.5	-36
Q2	-28	-28.2	-36
Q3	-28	-28.2	-36

NOTES:
1. Assembly 2A4 measurements made to ground.
2. Assembly 2A5 measurements made to 2A5T1-1.
3. Assembly 2A6 measurements made to 2A5T1-1.

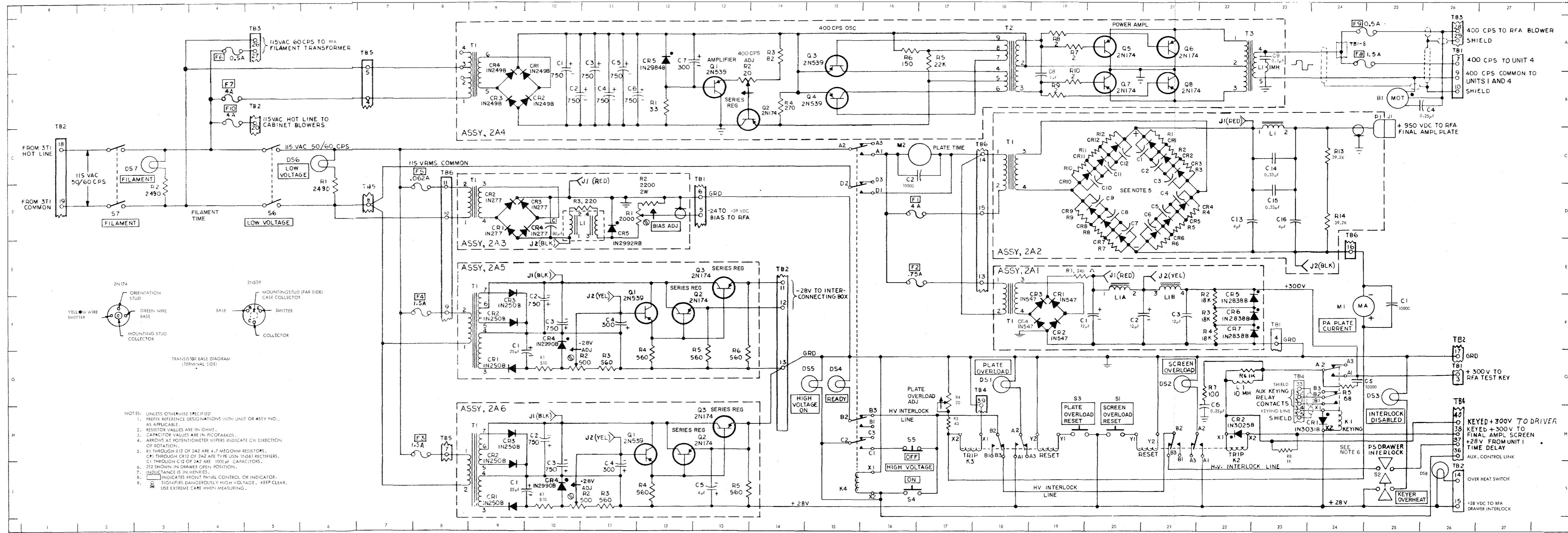

657-39

ORIGINAL

Figure 5-17. Power Supply PP-2796/WRA-3, Unit 2, Schematic Diagram

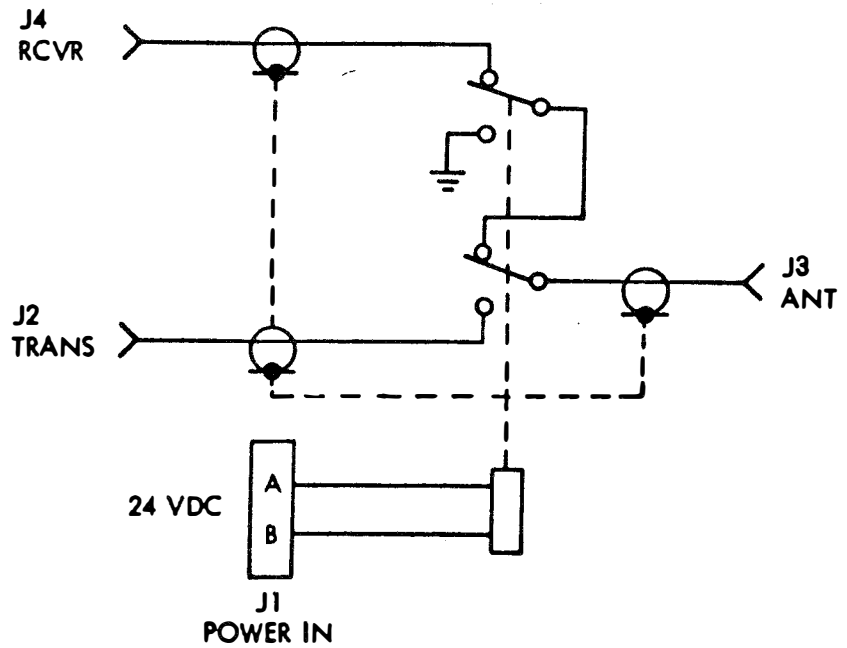

657-48

Figure 5-18. Relay Assembly RE-754/WRT-4,
Schematic Diagram

SECTION 6

PARTS LIST

6-1. INTRODUCTION.

Stock Number Identification Tables (SNIT) or Allowance Parts List (APL) issued by the Electronics Supply Office include Federal Stock Numbers and Source Maintenance and Recoverability Codes. Therefore, reference shall be made to the appropriate SNIT or APL for this information.

Reference designations have been assigned to identify all maintenance parts of the equipment and are included on drawings, diagrams, and the parts list. The letters of a reference designation indicate the kind of part (generic group), such as resistor, amplifier, electron tube, etc. The number differentiates between parts of the same generic group. Sockets associated with a particular plug-in device, such as an electron tube or a fuse, are identified by a reference designation which includes the reference designation of the plug-in device. For example, the socket for V1 is designated XV1.

The unit numbering system has been used for the identification of all units, assemblies, and parts. An example of this unit numbering system to reference a particular part is as follows:

2A2R1	-	Reference Designation
2	-	Unit 2
2A2	-	Assembly 2 of Unit 2
2A2R1	-	Resistor 1 of Assembly 2 of Unit 2

Most parts of the equipment are marked in the abbreviated form. In order to match these abbreviated markings with the parts list, it is necessary to prefix the abbreviated designation with the unit and assembly number.

6-2. LIST OF MAJOR UNITS.

Table 6-1 is a list of units and related assemblies

with assigned reference designations. When the reference designation of a part is known, this table will furnish ready reference to the major unit in which it is used.

6-3. MAINTENANCE PARTS LIST.

Table 6-2 is a maintenance parts list for Transmitter Group AN/WRA-3. This table lists all electrical parts shown in the schematic diagrams and those mechanical parts and assemblies which may require replacement. (Refer to provisioning documentation when a more extensive mechanical parts breakdown is required.) Maintenance parts for Electrical Frequency Synthesizer O-1115/URC, Unit 5, are not included in table 6-2, as this unit is government-furnished. (Refer to NAVSHIPS 94829 for information regarding Electrical Frequency Synthesizer O-1115/URC.)

Table 6-3 lists all the electrical parts in modification kit, electronic equipment MK-846/WRA-3.

6-4. LIST OF MANUFACTURERS.

Table 6-4 lists manufacturers of parts used in the equipment. The first column includes the abbreviations used in table 6-2 to identify manufacturers.

6-5. NOTES.

The following notes provide information as referenced in table 6-2.

1. This unit is government-furnished. Refer to NAVSHIPS 94829 for parts list.

2. Used only when Transmitter Group AN/WRA-3 is used as an exciter for Radio Set AN/URC-32 or Transmitting Set AN/WRT-2.

TABLE 6-1. TRANSMITTER GROUP AN/WRA-3, LIST OF UNITS AND ASSEMBLIES

REF. DESIG.	QUANT.	NAME OF UNIT OR ASSEMBLY	DESIGNATION	COLLOQUIAL NAME	PAGE
1	1	Radio Frequency Amplifier AM-2819/WRA-3	Unit 1	Radio Frequency Amplifier	6-3
2	1	Power Supply PP-2796/WRA-3	Unit 2		6-22
2A1	1	+300 Volt DC Power Supply	2A1	+300 Volt DC Power Supply	6-26
2A2	1	+950 Volt DC Power Supply	2A2	+950 Volt DC Power Supply	6-27
2A3	1	-24 to -39 Volt DC (Bias) Power Supply	2A3	-24 Volt DC (Bias) Power Supply	6-29
2A4	1	144 Volt (RMS) 400 CPS Power Supply	2A4	144 Volt (RMS) 400 CPS Power Supply	6-30
2A5	1	-28 Volt DC Power Supply	2A5	-28 Volt DC Power Supply	6-32
2A6	1	+28 Volt DC Power Supply	2A6	+28 Volt DC Power Supply	6-33
3	1	Electrical Equipment Cabinet CY-3022/WRA-3	Unit 3	Electrical Equipment Cabinet	6-35
4	1	Interconnecting Unit MX-3645/WRA-3	Unit 4	Interconnecting Unit	6-38
5	1	Electrical Frequency Synthesizer O-1115/URC	Unit 5	Synthesizer	6-38
6	1*	Transmitter Transfer Control C-6562/WRA-3	Unit 6	Transmitter Transfer Control	6-41
7	1	Relay Assembly RE-754/WRT-4	Unit 7	Antenna Transfer Relay	6-38
8	1	Resilient Mount MT-2661/WRA-3	Unit 8	Shockmount	N/A
9	1 set	Modification Kit MK-846/WRA-3 (Misc. parts)	Unit 9	Mod kit	N/A

* See Note 2

TABLE 6-2. TRANSMITTER GROUP AN/WRA-3
MAINTENANCE PARTS LIST

RADIO FREQUENCY AMPLIFIER AM-2819/WRA-3, UNIT 1

REF DESIG	NOTES	NAME AND DESCRIPTION	FIG. NO.
UNIT 1		RADIO FREQUENCY AMPLIFIER: Drawer mounted unit, overall dimensions 7-1/2 in. high, 17-3/4 in. wide, 22-1/2 in. depth; Hoffman part 8020000119-2	5-10, Sheet 1
1B1		BLOWER, VANEAXIAL: 115v, 400 cps, single phase, two pole, 22,500 rpm; Rotron Aximax 1; motor 623YS, Hoffman part 3009900808	5-10, Sheet 2
1C1		CAPACITOR: MIL-type CM15D511JN3	5-10, Sheet 1
1C2		CAPACITOR, VARIABLE, GLASS DIELECTRIC: Tubular, panel mount, 6.8 pf capacitance crossover, 24 carat gold plated, differential trimmer; JFD part DC404; Hoffman part 1079901505	5-10, Sheet 4
1C3		CAPACITOR: MIL-type CK06CW103M	5-10, Sheet 5
1C4		Same as 1C3	5-10, Sheet 5
1C5		Same as 1C3	5-10, Sheet 5
1C6		Same as 1C3	5-10, Sheet 5
1C7		Same as 1C3	5-10, Sheet 5
1C8		CAPACITOR: MIL-type CK70AW102M	5-10, Sheet 5
1C9		Same as 1C1	5-10, Sheet 5
1C10A to 1C10H		CAPACITOR, VARIABLE, AIR DIELECTRIC: 4 section; low capacity section 76.6 pf, high capacity section 184.0 pf effective capacitance, Radio Condenser Co. part 882503; Hoffman part 8180000056	5-10, Sheet 5
1C11		CAPACITOR: MIL-type CV11A250	5-10, Sheet 4
1C12		CAPACITOR: MIL-type CY10C150J	5-10, Sheet 5
1C13		CAPACITOR: MIL-type CY10C100J	5-10, Sheet 5
1C14		Same as 1C12	5-10, Sheet 5
1C15		Same as 1C11	5-10, Sheet 4

TABLE 6-2. TRANSMITTER GROUP AN/WRA-3
MAINTENANCE PARTS LIST (Continued)

RADIO FREQUENCY AMPLIFIER AM-2819/WRA-3, UNIT 1

REF DESIG	NOTES	NAME AND DESCRIPTION	FIG. NO.
1C16		Same as 1C11	5-10, Sheet 4
1C17		CAPACITOR: MIL-type CY10C220J	5-10, Sheet 5
1C18		Same as 1C13	5-10, Sheet 5
1C19		Same as 1C17	5-10, Sheet 5
1C20		Same as 1C11	5-10, Sheet 4
1C21		Same as 1C11	5-10, Sheet 4
1C22		Same as 1C17	5-10, Sheet 5
1C23		Same as 1C13	5-10, Sheet 5
1C24		Same as 1C17	5-10, Sheet 5
1C25		Same as 1C11	5-10, Sheet 4
1C26		Same as 1C11	5-10, Sheet 4
1C27		Same as 1C17	5-10, Sheet 5
1C28		CAPACITOR: MIL-type CY10C5R1C	5-10, Sheet 5
1C29		Same as 1C17	5-10, Sheet 5
1C30		Same as 1C11	5-10, Sheet 4
1C31		Same as 1C11	5-10, Sheet 4
1C32		Same as 1C17	5-10, Sheet 5
1C33		CAPACITOR: MIL-type CY10C3R0C	5-10, Sheet 5
1C34		Same as 1C17	5-10, Sheet 5
1C35		Same as 1C11	5-10, Sheet 4
1C36		CAPACITOR: MIL-type CK63AW103M	5-10, Sheet 5

TABLE 6-2. TRANSMITTER GROUP AN/WRA-3
MAINTENANCE PARTS LIST (Continued)

RADIO FREQUENCY AMPLIFIER AM-2819/WRA-3, UNIT 1

REF DESIG	NOTES	NAME AND DESCRIPTION	FIG. NO.
1C37		Same as 1C36	5-10, Sheet 5
1C38		Same as 1C8	5-10, Sheet 5
1C39		Same as 1C36	5-10, Sheet 5
1C40		Same as 1C1	5-10, Sheet 5
1C41		Same as 1C36	5-10, Sheet 5
1C42		Same as 1C8	5-10, Sheet 5
1C43		Same as 1C8	5-10, Sheet 5
1C44		Same as 1C8	5-10, Sheet 5
1C45		Same as 1C36	5-10, Sheet 5
1C46		Same as 1C11	5-10, Sheet 4
1C47		Not used	
1C48		Same as 1C11	5-10, Sheet 4
1C49		Not used	
1C50		Same as 1C11	5-10, Sheet 4
1C51		CAPACITOR: MIL-type CK60AW102M	5-10, Sheet 5
1C52		Same as 1C11	5-10, Sheet 4
1C53		Same as 1C51	5-10, Sheet 5
1C54		Same as 1C11	5-10, Sheet 4
1C55		Same as 1C51	5-10, Sheet 5
1C56		Same as 1C36	5-10, Sheet 5
1C57		Same as 1C36	5-10, Sheet 5

TABLE 6-2. TRANSMITTER GROUP AN/WRA-3
MAINTENANCE PARTS LIST (Continued)

RADIO FREQUENCY AMPLIFIER AM-2819/WRA-3, UNIT 1

REF DESIG	NOTES	NAME AND DESCRIPTION	FIG. NO.
1C58		Same as 1C36	5-10, Sheet 5
1C59		CAPACITOR: MIL-type CV11A070	5-10, Sheet 4
1C60		Same as 1C51	5-10, Sheet 5
1C61		Same as 1C59	5-10, Sheet 4
1C62		Same as 1C8	5-10, Sheet 5
1C63		Same as 1C59	5-10, Sheet 4
1C64		Not used	
1C65		Same as 1C59	5-10, Sheet 4
1C66		Not used	
1C67		Same as 1C59	5-10, Sheet 4
1C68		Not used	
1C69		CAPACITOR: MIL-type CY20C102J	5-10, Sheet 1
1C70		CAPACITOR, FIXED, CERAMIC DIELECTRIC: 10 pf, 5000 vdc, NPO, Centralab part 854A-10Z; Hoffman part 1079901503	5-10 Sheet 3
1C71		Same as 1C59	5-10, Sheet 3
1C72		Same as 1C69	5-10, Sheet 5
1C73		Same as 1C36	5-10, Sheet 1
1C74		Same as 1C8	5-10, Sheet 3
1C75		CAPACITOR, FIXED: 1100pf, p/o Eimac SK-630 socket 1XV5	5-10, Sheet 1
1C76		Same as 1C8	5-10, Sheet 3
1C77		Same as 1C8	5-10, Sheet 3
1C78		Same as 1C8	5-10, Sheet 3
1C79		CAPACITOR: MIL-type CM55C432JN3	5-10, Sheet 2

TABLE 6-2. TRANSMITTER GROUP AN/WRA-3
MAINTENANCE PARTS LIST (Continued)

RADIO FREQUENCY AMPLIFIER AM-2819/WRA-3, UNIT 1

REF DESIG	NOTES	NAME AND DESCRIPTION	FIG. NO.
1C80		CAPACITOR, FIXED, CERAMIC DIELECTRIC: 1000 pf, 5000 vdc, H1-K, Centralab part 858S-1000; Hoffman part 1079901504	5-10, Sheet 3
1C81		Same as 1C70	5-10, Sheet 3
1C82		CAPACITOR, FIXED, CERAMIC DIELECTRIC: 25 pf, $\pm 10\%$, 7500 vdc; Centralab part 850S-25Z; Hoffman part 1079901552	5-10, Sheet 1
1C83		Same as 1C82	5-10, Sheet 1
1C84		CAPACITOR, FIXED, CERAMIC DIELECTRIC: 100 pf, $\pm 10\%$, 5000 vdc; Centralab 850S-100N; Hoffman part 1079901553	5-10,
1C85		Same as 1C84	5-10, Sheet 1
1C86		Same as 1C84	5-10, Sheet 1
1C87		Same as 1C84	5-10, Sheet 1
1C88		Same as 1C84	5-10, Sheet 1
1C89		Same as 1C84	5-10, Sheet 1
1C90		CAPACITOR: MIL-type CM65D151JM1	5-10, Sheet 1
1C91		Same as 1C90	5-10, Sheet 1
1C92		CAPACITOR: MIL-type CM65D751JM1	5-10, Sheet 1
1C93		CAPACITOR: MIL-type CM65D152JM1	5-10, Sheet 1
1C94		Not used	
1C95		CAPACITOR: MIL-type CP53B1EF254K1	5-10, Sheet 2
1C96		Same as 1C8	5-10, Sheet 5
1C97		Same as 1C8	5-10, Sheet 5
1C98		Same as 1C8	5-10, Sheet 5
1C99		Not used	
1C100		Same as 1C8	5-10, Sheet 2

TABLE 6-2. TRANSMITTER GROUP AN/WRA-3
MAINTENANCE PARTS LIST (Continued)

RADIO FREQUENCY AMPLIFIER AM-2819/WRA-3, UNIT 1

REF DESIG	NOTES	NAME AND DESCRIPTION	FIG. NO.
1C101		Same as 1C8	5-10, Sheet 2
1C102		Same as 1C8	5-10, Sheet 2
1C103		Same as 1C8	5-10, Sheet 2
1C104		Same as 1C1	5-10, Sheet 3
1C105		Same as 1C84	5-10, Sheet 1
1C106		Same as 1C51	5-10, Sheet 5
1C107		CAPACITOR: MIL-type CK80AW152M	5-10, Sheet 3
1C108		Same as 1C8	5-10, Sheet 5
1C109		Same as 1C36	5-10, Sheet 1
1C110		Not used	
1C111		Same as 1C107	5-10, Sheet 2
1CR1		SEMICONDUCTOR DEVICE, DIODE: MIL-type 1N3012B	5-10, Sheet 5
1CR2		SEMICONDUCTOR DEVICE, DIODE: MIL-type 1N933	5-10, Sheet 3
1DS1		LAMP, INCANDESCENT: MIL-type MS25231-1819	5-10, Sheet 2
1DS2		LAMP, INCANDESCENT: MIL-type MS25237-328	5-10, Sheet 1
1DS3		Same as 1DS2	5-10, Sheet 1
1E1		TERMINATION, COAXIAL, SUBMINIATURE: 50 ohms impedance, Sealelectro 3006;Hoffman part 1199900614	5-10, Sheet 4
1E2		Same as 1E1	5-10, Sheet 1
1E3		Same as 1E1	5-10, Sheet 5
1E4		Same as 1E1	5-10, Sheet 1

TABLE 6-2. TRANSMITTER GROUP AN/WRA-3
MAINTENANCE PARTS LIST (Continued)

RADIO FREQUENCY AMPLIFIER AM-2819/WRA-3, UNIT 1

REF DESIG	NOTES	NAME AND DESCRIPTION	FIG. NO.
1E5		SLEEVE, COAXIAL, SUBMINIATURE: Sealectro 5223-1; Hoffman part 1199900667	5-10, Sheet 1
1E6		Same as 1E1	5-10, Sheet 5
1E7		SUPPRESSOR, PARASITIC: Six turns 16 AWG copper wire on 47 ohm, 2 watt composition resistor; Hoffman part 8050001502	5-10, Sheet 1
1E8		TERMINATION, COAXIAL, BNC: MIL-type MX-1684A/U	5-10, Sheet 1
1E9		SUPPRESSOR, PARASITIC: Four turns 18 AWG copper wire on 47 ohm, 1/2 watt composition resistor; Hoffman part 8050001503	5-10, Sheet 5
1E10		TERMINATION, COAXIAL, BNC: MIL-type MX-1744A/U	5-10, Sheet 2
1E11		Same as 1E1	5-10, Sheet 1
1E12		Same as 1E1	5-10, Sheet 1
1E13		Same as 1E1	5-10, Sheet 5
1E14		CHIMNEY, TUBE: 2-5/8 in. sq., Eimac part SK636A, Hoffman part 1949900088	5-10, Sheet 1
1E15		SUPPRESSOR, PARASITIC: Six turns #18 AWG copper wire on 47 ohm, 1 watt composition resistor; 22 pf glass capacitor; Hoffman part 8030000171	5-10, Sheet 1
1FL1		FILTER, RF, LOW PASS: 40 mc cutoff, 2-32 mc bandpass, 25 w, Microphase Corp. part LR14L3A; Hoffman part 8180000064	5-10, Sheet 2
1J1		ADAPTER CONNECTOR: BNC series UG-492C/U, MIL-type MS35177-492D	5-10, Sheet 2
1J2		Same as 1J1	5-10, Sheet 1
1J3		CONNECTOR, RECEPTACLE, ELECTRICAL: 50 ohms impedance, Sealectro part 3002; Hoffman part 1199900612	5-10, Sheet 1
1J4		Not used	
1J5		Same as 1J1	5-10, Sheet 2
1J6		CONNECTOR, RECEPTACLE, ELECTRICAL: High voltage; UG-931/U	5-10, Sheet 2
1J7		CONNECTOR, RECEPTACLE, ELECTRICAL Sealectro part 3003; Hoffman part 1199900640	5-10, Sheet 4

TABLE 6-2. TRANSMITTER GROUP AN/WRA-3
MAINTENANCE PARTS LIST (Continued)

RADIO FREQUENCY AMPLIFIER AM-2819/WRA-3, UNIT 1

REF DESIG	NOTES	NAME AND DESCRIPTION	FIG. NO.
1J8		Same as 1J1	5-10, Sheet 2
1J9		CONNECTOR: Subminax, #10-32NF-2A thread (Integral part of 1T2)	5-10, Sheet 4
1J10		CONNECTOR, RECEPTACLE, ELECTRICAL: right angle, type 3NC UG-535/U, part of rf attenuator	5-10, Sheet 1
1J11		Same as 1J10	5-10, Sheet 1
1J12		CONNECTOR, RECEPTACLE: type BNC (Integral part of 1FL1)	5-10, Sheet 2
1J13		Same as 1J12	5-10, Sheet 2
1L1		COIL, RADIO FREQUENCY: Variable, 12 uh $\pm 10\%$ to 22 uh $\pm 10\%$; Hoffman part 8050001494	5-10, Sheet 4
1L2		Same as 1L1	5-10, Sheet 4
1L3		COIL, RADIO FREQUENCY: Variable, 2.6 uh $\pm 10\%$ to 5 uh $\pm 10\%$; Hoffman part 8050001498	5-10, Sheet 4
1L4		Same as 1L3	5-10, Sheet 4
1L5		COIL, RADIO FREQUENCY: Variable, 0.7 uh $\pm 10\%$ to 1.4 uh $\pm 10\%$; Hoffman part 8050001495	5-10, Sheet 4
1L6		Same as 1L5	5-10, Sheet 4
1L7		COIL, RADIO FREQUENCY: Variable, 0.5 uh $\pm 10\%$ to 0.9 uh $\pm 10\%$; Hoffman part 8050001497	5-10, Sheet 4
1L8		Same as 1L7	5-10, Sheet 4
1L9		COIL, RADIO FREQUENCY: Variable, 0.25 uh $\pm 10\%$ to 0.45 uh $\pm 10\%$; Hoffman part 8050001496	5-10, Sheet 4
1L10		Same as 1L9	5-10, Sheet 4
1L11		Same as 1L1	5-10, Sheet 4
1L12		Same as 1L3	5-10, Sheet 4
1L13		Same as 1L5	5-10, Sheet 4

TABLE 6-2. TRANSMITTER GROUP AN/WRA-3
MAINTENANCE PARTS LIST (Continued)

RADIO FREQUENCY AMPLIFIER AM-2819/WRA-3, UNIT 1

REF DESIG	NOTES	NAME AND DESCRIPTION	FIG. NO.
1L14		Same as 1L7	5-10, Sheet 4
1L15		Same as 1L9	
1L16		Same as 1L1	5-10, Sheet 4
1L17		Same as 1L3	5-10, Sheet 4
1L18		Same as 1L5	5-10, Sheet 4
1L19		Same as 1L7	5-10, Sheet 4
1L20		Same as 1L9	5-10, Sheet 4
1L21		COIL, RADIO FREQUENCY: 2.5 mh \pm 5%, 250 ma; Millen part 34102; Hoffman part 1169900261	5-10, Sheet 2
1L22		CHOKER, RADIO FREQUENCY: 33 uh, 865 ma; MIL-type LT8K009; MS91189-31	5-10, Sheet 2
1L23		COIL, RADIO FREQUENCY: 0.5 uh; Hoffman part 8050001501	5-10, Sheet 1
1L24		COIL, RADIO FREQUENCY: Variable, 0.13 to 18.0 uh; E. F. Johnson part 229-202; Hoffman part 1169900262	5-10, Sheet 1
1L25		Same as 1L22	5-10, Sheet 2
1M1		METER, ELECTRICAL: Sealed, 2.695 in. dia, same as MIL-M-10304 type MR26B001DCMAR with zero adjustment except max depth and scale; Hoffman part 8180000070	3-2
1MP1		GEAR, SPUR: Hub: 21 teeth; 72 pitch; Dynaco part 356-21; Hoffman part 1319900105; p/o 1MP15	5-2
1MP2		GEAR, SPUR: Hub, 72 pitch; antibacklash; Dynaco part AB350-216; Hoffman part 1319900109; p/o 1MP15	5-2
1MP3		GEAR, SPUR: Hub, 64 pitch antibacklash; Dynaco part AB250-117; Hoffman part 1319900108; p/o 1MP15	5-2
1MP4		GEAR, SPUR: 63 teeth; 64 pitch; Hoffman part 8060002496; p/o 1MP15	5-2
1MP5		GEAR, SPUR: Hubless; 132 teeth; 48 pitch; Dynaco part 151-132; Hoffman part 1319900101; p/o 1MP15	5-2
1MP6		GEAR, SPUR: Hub; 22 teeth; Dynaco part 154-22; Hoffman part 1319900102; p/o 1MP15	5-2

TABLE 6-2. TRANSMITTER GROUP AN/WRA-3
MAINTENANCE PARTS LIST (Continued)

RADIO FREQUENCY AMPLIFIER AM-2819/WRA-3, UNIT 1

REF DESIG	NOTES	NAME AND DESCRIPTION	FIG. NO.
1MP7		GEAR, SPUR: Hub; 48 pitch; antibacklash; Dynaco part AB150-120; Hoffman part 1319900106; p/o 1MP15	5-2
1MP8		GEAR, SPUR: Hub; 24 teeth; Dynaco part 154-24; Hoffman part 1319900103; p/o 1MP15	5-2
1MP9		GEAR, SPUR: Hub; 69 pitch; antibacklash; Dynaco part AB250-80; Hoffman part 1319900107; p/o 1MP15	5-2
1MP10		IDLER GEAR ASSY: Hoffman part 8030000005	5-2
1MP11		GEAR, SPUR: Hub, 96 teeth, PIC part G7-96; Hoffman part 1319900122	5-2
1MP12		COUPLING, SHAFT, FLEXIBLE: Hoffman part 8060001858-1	5-2
1MP13		GEAR, SPUR: Hub; 96 teeth; PIC part G17-96; Hoffman part 1319900100	5-2
1MP14		Not used	
1MP15		GEAR, BOX, ASSY: Hoffman part 8020000289-1	5-2
1MP16		SPROCKET, WHEEL: Hoffman part 8060001470; p/o 1MP15	5-2
1MP17		SPROCKET, WHEEL: Hoffman part 8060001471; p/o 1MP15	5-2
1MP18		SPROCKET, WHEEL: Hoffman part 8060001492; p/o 1MP15	5-2
1MP19		SPROCKET, WHEEL: Volland part 6-12; Hoffman part 2009900013; p/o 1MP15	5-2
1MP20		CHAIN, BEAD: closed loop type, Volland part 6; Hoffman part 3009900876; p/o 1MP15	5-2
1MP21		UNIVERSAL JOINT: Modified from Falcon Machine part 6B5, Hoffman part 8060001765	5-2
1MP22		BEARING, SLEEVE: PIC part B11-9 modified; Hoffman part 8060001466-1; p/o 1MP15	5-2
1MP23		BEARING, SLEEVE: PIC part B11-9 modified; Hoffman part 8060001466-2; p/o 1MP15	5-2
1MP24		BEARING, SLEEVE: PIC part B11-9 modified; Hoffman part 8060001466-3; p/o 1MP15	5-2
1MP25		BEARING, SLEEVE: PIC part B11-9 modified; Hoffman part 8060001466-4; p/o 1MP15	5-2
1MP26		BEARING, SLEEVE: PIC part B11-9 modified; Hoffman part 8060001466-5; p/o 1MP15	5-2

TABLE 6-2. TRANSMITTER GROUP AN/WRA-3
MAINTENANCE PARTS LIST (Continued)

RADIO FREQUENCY AMPLIFIER AM-2819/WRA-3, UNIT 1

REF DESIG	NOTES	NAME AND DESCRIPTION	FIG. NO.
1MP27		BEARING: PIC B11-9 modified; Hoffman part 1019900094	5-2
1MP28		GEAR, SPUR: Hub; 20 teeth; 64 pitch; Boston Gear part Y6420; Hoffman part 1319900137	5-2
1MP29		GEAR, MODIFIED: Hub; 80 teeth; 64 pitch; modified Boston Gear Y6480; Hoffman part 8200000078	5-2
1MP30		PIN, SPRING: Steel, AMS-5506; Military Standard MS 171434; p/o 1MP15	5-2
1MP31		PIN, SPRING: Steel, AMS-5506; Military Standard MS 171435; p/o 1MP15	5-2
1MP32		PIN, SPRING: Steel, AMS-5506; Military Standard MS 171437; p/o 1MP15	5-2
1MP33		PIN, SPRING: Steel, AMS-5506; Military Standard MS 171438; p/o 1MP15	5-2
1MP34		PIN, SPRING: Steel, AMS-5506; Military Standard MS 171466; p/o 1MP15	5-2
1MP35		PIN, SPRING: Steel, AMS-5506; Military Standard MS 171468; p/o 1MP15	5-2
1MP36		PIN, SPRING: Steel, AMS-5506; Military Standard MS 171496; p/o 1MP15	5-2
1MP37		PIN, SPRING: Steel, AMS-5506; Military Standard MS 171498; p/o 1MP15	5-2
1MP38		PIN, SPRING: Steel, AMS-5506; Military Standard MS 171524; p/o 1MP15	5-2
1MP39		RING, RETAINING: Copper, per QQ-C-533 condition H; NAS-670-12; p/o 1MP15	5-2
1MP40		RING, RETAINING: Copper, per QQ-C-533 condition H; NAS-670-18; p/o 1MP15	5-2
1MP41		RING, RETAINING: Steel Std, 66 NOS; NAS-670-25; p/o 1MP15	5-2
1MP42		KNOB: MIL-type MS-91528-1N2D	3-2
1MP43		KNOB: MIL-type MS-91528-2K2D	3-2
1MP44		KNOB: MIL-type MS-91528-3S2D	3-2
1MP45		KNOB: MIL-type MS-91528-0N1B	3-2
1MP46		BUSHING SHAFT, PANEL: Birnback part 550A; Hoffman part 1019900108	5-2
1MP47		FILTER, AIR: AL alloy screen and frame, Hoffman part 8180000061	5-2

TABLE 6-2. TRANSMITTER GROUP AN/WRA-3
MAINTENANCE PARTS LIST (Continued)

RADIO FREQUENCY AMPLIFIER AM-2819/WRA-3, UNIT 1

REF DESIG	NOTES	NAME AND DESCRIPTION	FIG. NO.
1MP48		GROMMET, BLIND: Specification MIL-D-20693, type I, NMC part NMC-G57NB-2; Hoffman part 1349900047	5-2
1MP49		GROMMET, SPLIT: MIL-M-20693, type I nylon, color natural; NAS557-3C	5-2
1MP50		GROMMET, RUBBER: Rubbercraft part 9604; Hoffman part 1349900046	5-2
1MP51		TUNER ASSY: Hoffman part 8020000290	5-2
1MP52		SPRING, HELICAL, TORSION: Hoffman part 8150000163; p/o 1MP15	5-2
1MP53		SPRING, HELICAL, EXTENSION: Hoffman part 8150000164; p/o 1MP15	5-2
1MP54		SPRING, HELICAL, EXTENSION: Hoffman part 8150000165; p/o 1MP15	5-2
1MP55		SPRING, TENSION: Hoffman part 8150000166	5-2
1MP56		WHEEL, DETENT: Hoffman part 8060001481; p/o 1MP15	5-2
1MP57		Not used	
1MP58		STOP, DIAL: Hoffman part 8060001483; p/o 1MP15	5-2
1MP59		STOP, DIAL: Hoffman part 8060001484; p/o 1MP15	5-2
1MP60		BEARING ASSY: Hoffman part 8021000166-1	5-2
1MP61		RING, RETAINING: Waldes Kohinoor part 5100-25W; Hoffman part 1799900057; p/o 1MP10	5-2
1MP62		GEAR, SPUR: Hub, 72 teeth; AB2-72; Hoffman part 1319900121; p/o 1MP10	5-2
1MP63		SPRING, WIPER: Hoffman part 8150000196; p/o 1MP10	5-2
1MP64		PIN, SPRING: Military Standard MS 171436; p/o 1MP51	5-2
1MP65		COUPLING, SHAFT, FLEXIBLE: PIC part T7-3N; Hoffman part 3009900789	5-2
1MP66		BUSHING, SLEEVE: Hoffman part 8060001868; p/o 1MP51	5-2
1MP67		BEARING AND BUSHING ASSY: Hoffman part 8060001871-1	5-2
1P1		CONNECTOR, PLUG, ELECTRICAL: connector is used to adapt RG-188/U cable to BNC connector mating end; Dage part 1-150-4; Hoffman part 1199900589	5-10, Sheet 1
1P2		Same as 1P1	5-10, Sheet 1
1P3		CONNECTOR, PLUG, ELECTRICAL: right angle; for RG-188/U cable; Sealectro part 3005; Hoffman part 1199900613	5-10, Sheet 1
1P4		Same as 1P3	3-5
1P5		CONNECTOR, PLUG, ELECTRICAL: BNC series UG-88E/U; MIL-type MS35168-88E	5-10, Sheet 1

TABLE 6-2. TRANSMITTER GROUP AN/WRA-3
MAINTENANCE PARTS LIST (Continued)

RADIO FREQUENCY AMPLIFIER AM-2819/WRA-3, UNIT 1

REF. DESIG.	NOTES	NAME AND DESCRIPTION	FIG. NO.
1P6		Same as 1P5	5-10, Sheet 1
1P7		Same as 1P5	5-10, Sheet 2
1P8		Same as 1P5	5-10, Sheet 2
1P9		Same as 1P5	5-10, Sheet 1
1P10		Same as 1P5	5-10, Sheet 2
1P11		Same as 1P5	5-10, Sheet 2
1P12		Same as 1P5	5-10, Sheet 2
1R1		RESISTOR: MIL-type RL07AD201G	5-10, Sheet 2
1R2		Not used	
1R3		Not used	
1R4		Not used	
1R5		Same as 1R1	5-10, Sheet 5
1R6		Same as 1R1	5-10, Sheet 5
1R7		RESISTOR: MIL-type RL07AD101G	5-10, Sheet 5
1R8		Same as 1R7	5-10, Sheet 5
1R9		RESISTOR: MIL-type RL20AD471J	5-10, Sheet 5
1R10		Same as 1R9	5-10, Sheet 5
1R11		RESISTOR, VARIABLE, WIREWOUND: 500 ohms, 3/4 w; Bourns part 1162; Hoffman part 1829901593	5-10, Sheet 5
1R12		RESISTOR: MIL-type RL20AD103J	5-10, Sheet 5
1R13		Same as 1R12	5-10, Sheet 5
1R14		Same as 1R12	5-10, Sheet 5
1R15		RESISTOR: MIL-type RL20AD101J	5-10, Sheet 5
1R16		RESISTOR: MIL-type RL20AD123J	5-10, Sheet 5

TABLE 6-2. TRANSMITTER GROUP AN/WRA-3
MAINTENANCE PARTS LIST (Continued)

RADIO FREQUENCY AMPLIFIER AM-2819/WRA-3, UNIT 1

REF DESIG	NOTES	NAME AND DESCRIPTION	FIG. NO.
1R17		RESISTOR: MIL-type RL42AD472J	5-10, Sheet 5
1R18		RESISTOR: MIL-type RL20AD222J	5-10, Sheet 5
1R19		RESISTOR: MIL-type RE65G4991	5-10, Sheet 5
1R20		Same as 1R12	5-10, Sheet 5
1R21		RESISTOR: MIL-type RL20AD820J	5-10, Sheet 5
1R22		RESISTOR: MIL-type RL20AD272J	5-10, Sheet 5
1R23		RESISTOR: MIL-type RC42GF102K	5-10, Sheet 5
1R24		RESISTOR: MIL-type RC20GF104K	5-10, Sheet 5
1R25		RESISTOR: MIL-type RC32GF392K	5-10, Sheet 1
1R26		Same as 1R12	5-10, Sheet 1
1R27		Same as 1R15	5-10, Sheet 1
1R28		RESISTOR: MIL-type RL20AD392J	5-10, Sheet 3
1R29		RESISTOR: MIL-type RL20AD331J	5-10, Sheet 3
1R30		RESISTOR: MIL-type RL20AD102J	5-10, Sheet 3
1R31		Not used	
1R32		RESISTOR: MIL-type RL20AD510J	5-10, Sheet 1
1R33		RESISTOR, VARIABLE, COMPOSITION, DUAL: 50 ohms each section, linear taper $\pm 10\%$, Allen Bradley part JD1N048P500UA; Hoffman part 1829901594	5-10, Sheet 1
1R34		Same as 1R32	5-10, Sheet 1
1R35		RESISTOR: MIL-type RN60D24R9F	5-10, Sheet 1
1R36		RESISTOR, FIXED, WIREWOUND: 50 ohms $\pm 1\%$, 25 w, Dale Products type NH-25-50; Hoffman part 1829901353	5-10, Sheet 2
1R37		RESISTOR: MIL-type RN60B31R6F	5-10, Sheet 5

TABLE 6-2. TRANSMITTER GROUP AN/WRA-3
MAINTENANCE PARTS LIST (Continued)

RADIO FREQUENCY AMPLIFIER AM-2819/WRA-3, UNIT 1

REF. DESIG.	NOTES	NAME AND DESCRIPTION	FIG. NO.
1R38		Same as 1R32	5-10, Sheet 1
1R39		RESISTOR: MIL-type RL20AD121J	5-10, Sheet 1
1R40		Same as 1R39	5-10, Sheet 1
1R41		RESISTOR: MIL-type RL20AD203J	5-10, Sheet 5
1R42		Same as 1R41	5-10, Sheet 5
1R43		RESISTOR: MIL-type RC42GF124K	5-10, Sheet 3
1R44		Same as 1R43	5-10, Sheet 3
1R45		Same as 1R43	5-10, Sheet 3
1R46		Same as 1R43	5-10, Sheet 3
1R47		Same as 1R43	5-10, Sheet 3
1R48		Not used	
1R49		Not used	
1R50		Same as 1R12	5-10, Sheet 5
1R51		Same as 1R12	5-10, Sheet 5
1R52		Same as 1R12	5-10, Sheet 5
1R53		Same as 1R12	5-10, Sheet 5
1R54		Same as 1R12	5-10, Sheet 5
1R55		Not used	
1R56		RESISTOR, FIXED, WIREWOUND: 768 ohms $\pm 1\%$, 10 w, non-inductive; Dale Products type NH-10-768, Hoffman part 1829901476	5-10, Sheet 1
1R57		RESISTOR, FIXED, WIREWOUND: 6.65 ohms $\pm 1\%$, 10 w, non-inductive; Dale Products type NH-10-6.65, Hoffman part 1829901468	5-10, Sheet 1
1R58		RESISTOR, FIXED, WIREWOUND: 316 ohms $\pm 1\%$, 10 w, non-inductive; Dale Products type NH-10-316; Hoffman part 1829901475	5-10, Sheet 1

TABLE 6-2. TRANSMITTER GROUP AN/WRA-3
MAINTENANCE PARTS LIST (Continued)

RADIO FREQUENCY AMPLIFIER AM-2819/WRA-3, UNIT 1

REF. DESIG.	NOTES	NAME AND DESCRIPTION	FIG. NO.
1R59		RESISTOR, FIXED, WIREWOUND: 9.31 ohms $\pm 1\%$, 10 w, non-inductive; Dale Products type NH-10-9.31, Hoffman part 1829901469	5-10, Sheet 1
1R60		RESISTOR, FIXED, WIREWOUND: 215 ohms $\pm 1\%$, 10 w; non-inductive; Dale Products type NH-10-215, Hoffman part 1829901474	5-10, Sheet 1
1R61		RESISTOR, FIXED, WIREWOUND: 14.3 ohms $\pm 1\%$, 10 w; non-inductive; Dale Products type NH-10-14.3, Hoffman part 1829901470	5-10, Sheet 1
1R62		RESISTOR, FIXED, WIREWOUND: 121 ohms $\pm 1\%$, 10 w; non-inductive; Dale Products type NH-10-121, Hoffman part 1829901472	5-10, Sheet 1
1R63		RESISTOR, FIXED, WIREWOUND: 28.7 ohms $\pm 1\%$, 10 w; non-inductive; Dale Products type HN-10-28.7, Hoffman part 1829901471	5-10, Sheet 1
1R64		RESISTOR, FIXED, WIREWOUND: 187 ohms $\pm 1\%$, 10 w, non-inductive; Dale Products type NH-10-187; Hoffman part 1829901473	5-10, Sheet 1
1S1A thru 1S1L		SWITCH, ROTARY SELECTOR: 60° throw, 4 sections, Hoffman part 8050001507, 1 section per Hoffman part 8050001505, 1 section per Hoffman part 8050001506	5-10, Sheets 1 & 5
1S2		SWITCH, THERMAL: Time delay, 6.3 v, 5 w, heating element, 30 sec delay, contacts SPST, normally open, rated 3.0 amp at 150 vdc; Thos. A. Edison part B2024; Hoffman part 1749900043	5-10, Sheet 1
1S3		SWITCH, RF TRANSMISSION LINE: SPDT, 3 BNC connector termination, 50 w, 500 v, Automatic Metals Products part 10CRM-1/2-02; Hoffman part 2039900081	5-10, Sheet 1
1S4		SWITCH, TOGGLE: MIL-type MS35058-31	3-2
1S5		SWITCH, INTERLOCK: MIL-type MS16106-2	5-10, Sheet 2
1S6		SWITCH, TOGGLE: MIL-type MS35059-23	5-10, Sheet 1
1S7		SWITCH, SUBMINIATURE: SPDT, 4 amps at 28 vdc, MS24547-1 with Micro Switch JX41 actuator	5-10, Sheet 2
1S8		SWITCH, SUBMINIATURE: SPDT, 4 amps at 28 vdc, MS24547-1 with Micro Switch JX51 actuator	5-10, Sheet 1
1T1		TRANSFORMER, RADIO FREQUENCY: 50 ohms impedance input unbalanced to 200 ohms impedance balanced, ± 1 db 0.350 mc to 3.650 mc; Hoffman part 8050001456	5-10, Sheet 4

TABLE 6-2. TRANSMITTER GROUP AN/WRA-3
MAINTENANCE PARTS LIST (Continued)

RADIO FREQUENCY AMPLIFIER AM-2819/WRA-3, UNIT 1

REF. DESIG.	NOTES	NAME AND DESCRIPTION	FIG. NO.
1T2		TRANSFORMER, RADIO FREQUENCY: 50 ohms impedance input unbalanced to 200 ohms impedance balanced, ± 0.2 db 2-32 mc, 0.5 db insertion loss; CGS Labs part HPC-200/50A; Hoffman part 2109900050. Includes 1J9 as input connector	5-10, Sheet 4
1T3		TRANSFORMER, POWER, STEP-DOWN: Primary 105, 115, 125 vrms, 50/60 cps, secondary 6.3 vct at 2.0 amps; Triad part HSM225; Raytheon part 292-5637G1; Hoffman part 2109900051	5-10, Sheet 1
1T4		TRANSFORMER, POWER, STEP-DOWN: Primary 105, 115, 125 vrms, 50/60 cps, secondary 6.3 vct at 3.6 amp, Triad part HSM226; Raytheon part 292-5638G1; Hoffman part 2109900052	5-10, Sheet 1
1TB1		TERMINAL BOARD: MIL-type 7TB8	5-10, Sheet 2
1TB2		Same as 1TB1	5-10, Sheet 2
1TB3		Not used	
1TB4		Not used	
1TB5		Not used	
1TB6		TERMINAL BOARD: CTC part X2030; Hoffman part 8031100791	5-10, Sheet 5
1TB7		TERMINAL BOARD: Hoffman part 8080000551-1	5-10, Sheet 3
1TB8		TERMINAL BOARD: Hoffman part 8080000453-1	5-10, Sheet 3
1TB9		TERMINAL BOARD: Hoffman part 8080000457-1	5-10, Sheet 5
1V1		ELECTRON TUBE: MIL-type 5725/6AS6W	5-10, Sheet 4
1V2		Same as 1V1	5-10, Sheet 4
1V3		ELECTRON TUBE: MIL-type 6AU6WB	5-10, Sheet 4
1V4		ELECTRON TUBE: MIL-type 6CL6	5-10, Sheet 4
1V5		ELECTRON TUBE: Eimac part 4CX250B	5-10, Sheet 1
1XDS1		LAMPHOLDER: MIL-type LH75LC14RD	5-10, Sheet 2
1XDS2		LIGHT, PANEL: MIL-type MS25010C12B	5-10, Sheet 1
1XDS3		Same as 1XDS2	5-10, Sheet 1
1XS2		SOCKET, OCTAL: MIL-type TS101P02	5-10, Sheet 1

TABLE 6-2. TRANSMITTER GROUP AN/WRA-3
MAINTENANCE PARTS LIST (Continued)

RADIO FREQUENCY AMPLIFIER AM-2819/WRA-3, UNIT 1

REF DESIG	NOTES	NAME AND DESCRIPTION	FIG. NO.
1XV1		SOCKET, ELECTRON TUBE: MIL-type TS102C03 modified, Hoffman part 8140000189	5-10, Sheet 4
1XV2		Same as 1XV1	5-10, Sheet 4
1XV3		Same as 1XV1	5-10, Sheet 4
1XV4		SOCKET, ELECTRON TUBE: MIL-type TS103C03 modified, Hoffman part 8140000190	5-10, Sheet 4
1XV5		SOCKET, ELECTRON TUBE: Octal, Eimac part SK-630-6000, Hoffman part 1949900089	5-10, Sheet 1
1TB6		TERMINAL BOARD: Mounting board assy for cathode and screen circuits of V3 and V4; CTC part X2030; Hoffman part 8031100791	5-10, Sheet 5
1R15		RESISTOR: MIL-type RL20AD101J	
1R16		RESISTOR: MIL-type RL20AD123J	
1R21		RESISTOR: MIL-type RL20AD820J	
1R22		RESISTOR: MIL-type RL20AD272J	
1TB7		TERMINAL BOARD: Mounting board assy for output meter network; c/o Hoffman printed circuit board 8080000551 with 2 terminals, USECO part 2510B; 2 standoffs, USECO part 1530B; 8 eyelets, Circon part CE43F	5-10, Sheet 3
1C104		CAPACITOR: MIL-type CM15D511JN3	
1CR2		SEMICONDUCTOR DEVICE, DIODE: MIL-type 1N933	
1R28		RESISTOR: MIL-type RL20AD392J	
1R29		RESISTOR: MIL-type RL20AD331J	
1R30		RESISTOR: MIL-type RL20AD102J	
1TB8		TERMINAL BOARD: Mounting board assy for screen bleeder network V5; c/o Hoffman part 8080000453 with 10 terminals, USECO part 1280B-1	5-10, Sheet 3
1R43		RESISTOR: MIL-type RC42GF124K	
1R44		Same as 1R43	
1R45		Same as 1R43	
1R46		Same as 1R43	
1R47		Same as 1R43	

TABLE 6-2. TRANSMITTER GROUP AN/WRA-3
MAINTENANCE PARTS LIST (Continued)

RADIO FREQUENCY AMPLIFIER AM-2819/WRA-3, UNIT 1

REF DESIG.	NOTES	NAME AND DESCRIPTION	FIG. NO.
1TB9		TERMINAL BOARD: Mounting board assy for balanced modulator output network; c/o Hoffman part 8080000457 with 2 standoffs CTC part X1898A; 8 terminals, USECO part 1280C-6	5-10, Sheet 5
1C7		CAPACITOR: MIL-type CK06CW103M	
1C9		CAPACITOR: MIL-type CM15D511JN3	
1R12		RESISTOR: MIL-type RL20AD103J	
1R13		Same as 1R12	
1R14		Same as 1R12	

TABLE 6-2. TRANSMITTER GROUP AN/WRA-3
MAINTENANCE PARTS LIST (Continued)

POWER SUPPLY PP-2796/WRA-3, UNIT 2

REF DESIG	NOTES	NAME AND DESCRIPTION	FIG. NO.
UNIT 2		POWER SUPPLY: Consisting of +300 vdc power supply; +950 vdc power supply; adjustable -24 to -39 vdc power supply; -28 vdc power supply; +28 vdc power supply and 47.5/63 cps to 400 cps frequency changer; Hoffman part 8020000117-2	5-1
2B1		BLOWER, VANEAXIAL: 115 V, 400 cps, single phase, two pole, 22,500 rpm; Rotron Aximax 1; motor 623YS, Hoffman part 3009900808	5-3, Sheet 2
2C1		CAPACITOR: MIL-type CK63AW103M	5-3, Sheet 2
2C2		Same as 2C1	5-3, Sheet 2
2C3		Not used	
2C4		CAPACITOR: MIL-type CP53B1EF254K1	5-3, Sheet 2
2C5		CAPACITOR: MIL-type CH05A1NF103K	5-3, Sheet 3
2C6		Same as 2C4	5-3, Sheet 3
2CR1		SEMICONDUCTOR DEVICE, DIODE: MIL-type 1N3031B	5-3, Sheet 3
2CR2		SEMICONDUCTOR DEVICE, DIODE: MIL-type 1N3025B	5-3, Sheet 3
2DS1		LAMP, INCANDESCENT: MIL-type MS25231-1819	5-3, Sheet 1
2DS2		Same as 2DS1	5-3, Sheet 1
2DS3		Same as 2DS1	5-3, Sheet 1
2DS4		Same as 2DS1	5-3, Sheet 1
2DS5		Same as 2DS1	5-3, Sheet 1
2DS6		Same as 2DS1	5-3, Sheet 1
2DS7		Same as 2DS1	5-3, Sheet 1
2DS8		Same as 2DS1	5-3, Sheet 1
2E1		TERMINAL, STUD, INSULATED: MIL-type SE19XD01	5-3, Sheet 3
2F1		FUSE: MIL-type F02A250V4AS	5-3, Sheet 1

TABLE 6-2. TRANSMITTER GROUP AN/WRA-3
MAINTENANCE PARTS LIST (Continued)

POWER SUPPLY PP-2796/WRA-3, UNIT 2

REF DESIG	NOTES	NAME AND DESCRIPTION	FIG. NO.
2F2		FUSE: MIL-type F02B250V 3/4AS	5-3, Sheet 1
2F3		FUSE: MIL-type F02B125V1 1/2AS	5-3, Sheet 1
2F4		Same as 2F3	5-3, Sheet 1
2F5		FUSE: MIL-type F02B250V 1/16AS	5-3, Sheet 1
2F6		FUSE: MIL-type F02B250V 1/2AS	5-3, Sheet 1
2F7		Same as 2F1	5-3, Sheet 1
2F8		Same as 2F3	5-3, Sheet 1
2F9		Same as 2F6	5-3, Sheet 1
2F10		Same as 2F1	5-3, Sheet 1
2J1		CONNECTOR, RECEPTACLE, ELECTRICAL: Straight adapter, two female ends, IPC part 12650; Hoffman part 1199900609	5-3, Sheet 3
2K1		RELAY, ELECTRICAL ARMATURE: Coil, 28 vdc minimum; DPDT, Leach part 9229-4457; Hoffman part 1749900041	5-3, Sheet 3
2K2		RELAY, ELECTRICAL, ARMATURE: DPDT, coil, 100 dc ma max at 35 dc ma; Leach part 9235-6123; Hoffman part 1749900042	5-3, Sheet 3
2K3		Same as 2K2	5-3, Sheet 3
2K4		RELAY, ELECTRICAL ARMATURE: Coil, 28 vdc, 150 ma, contacts 4, form C, MIL-type MS25267-D1	5-3, Sheet 3
2L1		CHOKE, RADIO FREQUENCY: MIL-type LT4K073; MS75055-5	5-3, Sheet 3
2M1		METER, ELECTRICAL: MIL-type MR26B300DCMAR	5-3, Sheet 1
2M2		METER, ELAPSED TIME: 2 w, 115 volts, 60 cps, Haydon Div. General Time part 7010-010; Hoffman part 3009900284	5-3, Sheet 2
2M3		Not used	
2R1		RESISTOR: MIL-type RE70G2491	5-3, Sheet 3
2R2		Same as 2R1	5-3, Sheet 3
2R3		RESISTOR: MIL-type RW55G430	5-3, Sheet 3

TABLE 6-2. TRANSMITTER GROUP AN/WRA-3
MAINTENANCE PARTS LIST (Continued)

POWER SUPPLY PP-2796/WRA-3, UNIT 2

REF. DESIG.	NOTES	NAME AND DESCRIPTION	FIG. NO.
2R4		RESISTOR: MIL-type RA20LASB200A	5-3, Sheet 3
2R5		RESISTOR: MIL-type RC32GF680K	5-3, Sheet 3
2R6		RESISTOR: MIL-type RC20GF102K	5-3, Sheet 3
2R7		RESISTOR: MIL-type RC20GF101K	5-3, Sheet 3
2R8		RESISTOR: MIL-type RL20AD102J	5-3, Sheet 3
2S1		SWITCH, PUSH: Momentary contact, normally open, SPDT, 28 vdc at 2.5 amp; Control Switch A4-20-270; Hoffman part 2039900133	5-3, Sheet 1
2S2		SWITCH, INTERLOCK: MIL-type MS16106-2	5-3, Sheet 3
2S3		Same as 2S1	5-3, Sheet 1
2S4		SWITCH, PUSH: 3 terminal, momentary contact, normally open, 28 vdc, 10 amp resistive load; Control Switch W104PB6-298; Hoffman part 2039900131	5-3, Sheet 1
2S5		SWITCH, PUSH: 3 terminal, momentary contacts, normally closed, 28 vdc, 10 amp resistive load; Control Switch W105PB6R-93; Hoffman part 2039900132	5-3, Sheet 1
2S6		SWITCH, TOGGLE: DPST, MIL-type MS35059-22	5-3, Sheet 1
2S7		Same as 2S6	5-3, Sheet 1
2TB1		TERMINAL BOARD: MIL-type 8TB10	5-3, Sheet 3
2TB2		Same as 2TB1	5-3, Sheet 3
2TB3		Same as 2TB1	5-3, Sheet 3
2TB4		Same as 2TB1	5-3, Sheet 3
2TB5		TERMINAL BOARD: MIL-type 8TB8	5-3, Sheet 3
2TB6		Same as 2TB5	5-3, Sheet 3
2TB7		TERMINAL BOARD: Hoffman part 8031100773-1	5-3, Sheet 3
2XDS1		LAMPHOLDER: MIL-type LH75LC14RD	5-3, Sheet 1
2XDS2		Same as 2XDS1	5-3, Sheet 1

TABLE 6-2. TRANSMITTER GROUP AN/WRA-3
MAINTENANCE PARTS LIST (Continued)

POWER SUPPLY PP-2796/WRA-3, UNIT 2

REF. DESIG.	NOTES	NAME AND DESCRIPTION	FIG. NO.
2XDS3		Same as 2XDS1	5-3, Sheet 1
2XDS4		LAMPHOLDER: MIL-type LH75LC14YD	5-3, Sheet 1
2XDS5		LAMPHOLDER: MIL-type LH75LC14GD	5-3, Sheet 1
2XDS6		Same as 2XDS5	5-3, Sheet 1
2XDS7		Same as 2XDS5	5-3, Sheet 1
2XDS8		Same as 2XDS1	5-3, Sheet 1
2XF1		FUSEHOLDER: MIL-type FHL11G	5-3, Sheet 1
2XF2		Same as 2XF1	5-3, Sheet 1
2XF3		Same as 2XF1	5-3, Sheet 1
2XF4		Same as 2XF1	5-3, Sheet 1
2XF5		Same as 2XF1	5-3, Sheet 1
2XF6		Same as 2XF1	5-3, Sheet 1
2XF7		Same as 2XF1	5-3, Sheet 1
2XF8		Same as 2XF1	5-3, Sheet 1
2XF9		Same as 2XF1	5-3, Sheet 1
2XF10		Same as 2XF1	5-3, Sheet 1

TABLE 6-2. TRANSMITTER GROUP AN/WRA-3
MAINTENANCE PARTS LIST (Continued)

POWER SUPPLY, +300 V

REF. DESIG.	NOTES	NAME AND DESCRIPTION	FIG. NO.
UNIT 2 ASSY 1		POWER SUPPLY: +300 vdc $\pm 5\%$ at 80 ma with 115 vrms, 60 cps input; output $\pm 5\%$ with inputs $\pm 10\%$, 47.5 to 63 cps, and output load of zero to 80 ma. Ripple plus noise max 100 millivolts rms; Hoffman part 8021100079-1	5-1
2A1C1		CAPACITOR: MIL-type CL16CT120UP3	5-4
2A1C2		Same as 2A1C1	5-4
2A1C3		Same as 2A1C1	5-4
2A1CR1		SEMICONDUCTOR DEVICE, DIODE: MIL-type 1N547	5-4
2A1CR2		Same as 2A1CR1	5-4
2A1CR3		Same as 2A1CR1	5-4
2A1CR4		Same as 2A1CR1	5-4
2A1CR5		SEMICONDUCTOR DEVICE, DIODE: MIL-type 1N2838B	5-4
2A1CR6		Same as 2A1CR5	5-4
2A1CR7		Same as 2A1CR5	5-4
2A1J1		JACK, TIP: red, MIL-type MS16108-2A	5-4
2A1J2		JACK, TIP: yellow, MIL-type MS16108-8A	5-4
2A1L1		CHOKE, FILTER: 2.3 h; Triad Transformer Corp part 15521; Hoffman part 8180000045	5-4
2A1R1		RESISTOR: MIL-type RW31V241	5-4
2A1R2		RESISTOR: MIL-type RC42GF183K	5-4
2A1R3		Same as 2A1R2	5-4
2A1R4		Same as 2A1R2	5-4
2A1T1		TRANSFORMER, POWER: 4 terminals, 535 volts; Triad Transformer Corp part 68009; Hoffman part 8180000048	5-4

TABLE 6-2. TRANSMITTER GROUP AN/WRA-3
MAINTENANCE PARTS LIST (Continued)

POWER SUPPLY, +950 V

REF. DESIG.	NOTES	NAME AND DESCRIPTION	FIG. NO.
UNIT 2 ASSY 2		POWER SUPPLY: +950 vdc ± 15 v at 220 ma with 115 v 60 cps input. Output ± 150 v at 220 ma or ± 250 v at no load of nominal value, with input of 115 v $\pm 10\%$ and 47.5 to 63 cps. Ripple and noise max 10 v; Hoffman part 8021100081-1	5-1
2A2C1		CAPACITOR: MIL-type CK62BX102K	5-5
2A2C2		Same as 2A2C1	5-5
2A2C3		Same as 2A2C1	5-5
2A2C4		Same as 2A2C1	5-5
2A2C5		Same as 2A2C1	5-5
2A2C6		Same as 2A2C1	5-5
2A2C7		Same as 2A2C1	5-5
2A2C8		Same as 2A2C1	5-5
2A2C9		Same as 2A2C1	5-5
2A2C10		Same as 2A2C1	5-5
2A2C11		Same as 2A2C1	5-5
2A2C12		Same as 2A2C1	5-5
2A2C13		CAPACITOR: MIL-type CP70B1EH405K1	5-5
2A2C14		CAPACITOR, FIXED, PAPER DIELECTRIC: 0.33 uf $\pm 10\%$, 600 vdc working; MIL-C-25 type CP05A1KF334K3	5-5
2A2C15		Same as 2A2C14	5-5
2A216		Same as 2A2C13	5-5
2A2CR1		SEMICONDUCTOR DEVICE, DIODE: MIL-type 1N561	5-5
2A2CR2		Same as 2A2CR1	5-5
2A2CR3		Same as 2A2CR1	5-5
2A2CR4		Same as 2A2CR1	5-5
2A2CR5		Same as 2A2CR1	5-5
2A2CR6		Same as 2A2CR1	5-5
2A2CR7		Same as 2A2CR1	5-5
2A2CR8		Same as 2A2CR1	5-5

TABLE 6-2. TRANSMITTER GROUP AN/WRA-3
MAINTENANCE PARTS LIST (Continued)

POWER SUPPLY, +950 V

REF. DESIG.	NOTES	NAME AND DESCRIPTION	FIG. NO.
2A2CR9		Same as 2A2CR1	5-5
2A2CR10		Same as 2A2CR1	5-5
2A2CR11		Same as 2A2CR1	5-5
2A2CR12		Same as 2A2CR1	5-5
2A2J1		Same as 2A1J1	5-5
2A2J2		JACK, TIP: black, MIL-type MS16108-3A	5-5
2A2L1		CHOKE, FILTER: 2 hy at 220 ma dc, Tride Transformer Corp part 15520; Hoffman part 818000049	5-5
2A2P1		CONNECTOR, PLUG, ELECTRICAL: BNC 5000 v; Dage part 4934-1; Hoffman part 1199900608	5-5
2A2R1		RESISTOR: MIL-type RC32GF475K	5-5
2A2R2		Same as 2A2R1	5-5
2A2R3		Same as 2A2R1	5-5
2A2R4		Same as 2A2R1	5-5
2A2R5		Same as 2A2R1	5-5
2A2R6		Same as 2A2R1	5-5
2A2R7		Same as 2A2R1	5-5
2A2R8		Same as 2A2R1	5-5
2A2R9		Same as 2A2R1	5-5
2A2R10		Same as 2A2R1	5-5
2A2R11		Same as 2A2R1	5-5
2A2R12		Same as 2A2R1	5-5
2A2R13		RESISTOR: MIL-type RE75G3922	5-5
2A2R14		Same as 2A2R13	5-5
2A2T1		TRANSFORMER, POWER: 1200 peak working volts; Triad Transformer Corp part 68008; Hoffman part 8180000050	5-5

TABLE 6-2. TRANSMITTER GROUP AN/WRA-3
MAINTENANCE PARTS LIST (Continued)

POWER SUPPLY, 0-39 V

REF. DESIG.	NOTES	NAME AND DESCRIPTION	FIG. NO.
UNIT 2 ASSY 3		POWER SUPPLY: Bias, output -39 vdc $\pm 5\%$ with 2A3R1 set for maximum output voltage at no load and with input of 115 vrms, 60 cps; output voltage $\pm 1\%$ with inputs of 115 vrms $\pm 10\%$, at 47.5 to 63 cps. Ripple plus noise max 10 mv rms; output voltage adjustable from approximately -24 volts dc to max above; Hoffman part 8021100078-1	5-1
2A3C1		CAPACITOR: MIL-type CL14CK800UP3	5-6
2A3CR1		SEMICONDUCTOR DEVICE, DIODE: MIL-type 1N277	5-6
2A3CR2		Same as 2A3CR1	5-6
2A3CR3		Same as 2A3CR1	5-6
2A3CR4		Same as 2A3CR1	5-6
2A3CR5		SEMICONDUCTOR DEVICE, DIODE: MIL-type 1N2992RB	5-6
2A3J1		Same as 2A1J1	5-6
2A3J2		Same as 2A2J2	5-6
2A3L1		CHOKE, FILTER: 4 terminals, terminals 1-2, 0.750 mh, terminals 3-4, 0.308 mh; Triad Transformer Corp part 15522; Hoffman part 8180000046	5-6
2A3R1		RESISTOR: MIL-type RT12C2 L202	5-6
2A3R2		RESISTOR: MIL-type RC42GF222K	5-6
2A3R3		RESISTOR: MIL-type RC42GF221K	5-6
2A3T1		TRANSFORMER, POWER: 4 terminals 47.5 cps to 63 cps; 360 peak working volts; Triad Transformer Corp part 68010; Hoffman part 8180000047	5-6
2A3TB1		TERMINAL BOARD: Hoffman part 8031100772-1	5-6

TABLE 6-2. TRANSMITTER GROUP AN/WRA-3
MAINTENANCE PARTS LIST (Continued)

POWER SUPPLY, 144 V (RMS) 400 CPS

REF. DESIG.	NOTES	NAME AND DESCRIPTION	FIG. NO.
UNIT 2 ASSY 4		POWER SUPPLY, 144 V (RMS) 400 CPS: Frequency converter, output 144 v \pm 20 v at 0.17 amp load, with input of 115 v rms 60 cps; output voltage \pm 25 cps of 400 cps with input of 115 vrms \pm 10%, 47.5 to 63 cps, and output load of 0.17 to 1.4 amps, Hoffman part 8021100082-1	5-1
2A4C1		CAPACITOR, FIXED, ELECTROLYTIC: 750 pf +50% -15%, 60 vdc working; Mallory part XTV757T060POE, Hoffman part 1079901554	5-7, Sheet 2
2A4C2		Same as 2A4C1	5-7, Sheet 2
2A4C3		Same as 2A4C1	5-7, Sheet 2
2A4C4		Same as 2A4C1	5-7, Sheet 2
2A4C5		Same as 2A4C1	5-7, Sheet 2
2A4C6		Same as 2A4C1	5-7, Sheet 2
2A4C7		CAPACITOR: MIL-type CL25BH301UP3	5-7, Sheet 1
2A4C8		CAPACITOR: MIL-type CP09A1KB105K3	5-7, Sheet 2
2A4C9		CAPACITOR: MIL-type CP05A1KF104K3	5-7, Sheet 1
2A4CR1		SEMICONDUCTOR DEVICE, DIODE: MIL-type 1N249B	5-7, Sheet 2
2A4CR2		Same as 2A4CR1	5-7, Sheet 2
2A4CR3		Same as 2A4CR1	5-7, Sheet 2
2A4CR4		Same as 2A4CR1	5-7, Sheet 2
2A4CR5		SEMICONDUCTOR DEVICE, DIODE: MIL-type 1N2984B	5-7, Sheet 2
2A4L1		COIL, RF: Toroid; 1 mh; Triad part EM-001-A; Hoffman part 1169900306	5-7, Sheet 1
2A4Q1		TRANSISTOR: MIL-type 2N539	5-7, Sheet 1
2A4Q2		TRANSISTOR: MIL-type 2N174	5-7, Sheet 1
2A4Q3		Same as 2A4Q1	5-7, Sheet 1
2A4Q4		Same as 2A4Q1	5-7, Sheet 1

* Not applicable.

TABLE 6-2. TRANSMITTER GROUP AN/WRA-3
MAINTENANCE PARTS LIST (Continued)

POWER SUPPLY, 144 V (RMS) 400 CPS

REF. DESIG.	NOTES	NAME AND DESCRIPTION	FIG. NO.
2A4Q5		Same as 2A4Q2	5-7, Sheet 1
2A4Q6		Same as 2A4Q2	5-7, Sheet 1
2A4Q7		Same as 2A4Q2	5-7, Sheet 1
2A4Q8		Same as 2A4Q2	5-7, Sheet 1
2A4R1		RESISTOR: MIL-type RC42GF330K	5-7, Sheet 1
2A4R2		RESISTOR: MIL-type RT12C2L200	5-7, Sheet 1
2A4R3		RESISTOR: MIL-type RC42GF820K	5-7, Sheet 1
2A4R4		RESISTOR: MIL-type RC42GF271K	5-7, Sheet 1
2A4R5		RESISTOR: MIL-type RC32GF223K	5-7, Sheet 1
2A4R6		RESISTOR: MIL-type RC32GF151K	5-7, Sheet 1
2A4R7		RESISTOR: MIL-type RW69V2RO	5-7, Sheet 1
2A4R8		Same as 2A4R7	5-7, Sheet 1
2A4R9		Same as 2A4R7	5-7, Sheet 1
2A4R10		Same as 2A4R7	5-7, Sheet 1
2A4T1		TRANSFORMER, POWER: Primary, 105-115-125 v at 60 cps $\pm 10\%$, secondary 23.8 v rms $\pm 1\%$ with 11 amp load, 47.5 to 63 cps, 373 working volts; Triad Transformer Corp part 68129; Hoffman part 818000041	5-7, Sheet 1
2A4T2		TRANSFORMER: Oscillator, 400 cps $\pm 5\%$, 175 working volts; Triad Transformer Corp part 68066; Hoffman part 818000042	5-7, Sheet 1
2A4T3		TRANSFORMER, POWER: Primary 50 v p-p square wave 400 cps, secondary 308 v p-p at 1.4a rms; Triad Transformer Corp part 68067; Hoffman part 818000040	5-7, Sheet 1

TABLE 6-2. TRANSMITTER GROUP AN/WRA-3
MAINTENANCE PARTS LIST (Continued)

POWER SUPPLY, -28 VDC

REF. DESIG.	NOTES	NAME AND DESCRIPTION	FIG. NO.
UNIT 2 ASSY 5		POWER SUPPLY, -28 VDC: Two outputs 0.7a and 1.4a with 115 v 60 cps input; output voltage ± 1 v of nominal value with input of 115 v $\pm 10\%$ and 47.5 to 63 cps and output load of 0 to full loads; ripple plus noise max 50 mv rms; Hoffman part 8031100080-1	5-1
2A5C1		CAPACITOR: MIL-type CL65BP250MP3	5-8
2A5C2		Same as 2A4C1	5-8
2A5C3		Same as 2A4C1	5-8
2A5C4		Same as 2A4C7	5-8
2A5CR1		SEMICONDUCTOR DEVICE, DIODE: MIL-type 1N250B	5-8
2A5CR2		Same as 2A5CR1	5-8
2A5CR3		Same as 2A5CR1	5-8
2A5CR4		SEMICONDUCTOR DEVICE, DIODE: MIL-type 1N2990B	5-8
2A5J1		Same as 2A2J2	5-8
2A5J2		Same as 2A1J2	5-8
2A5Q1		Same as 2A4Q1	5-8
2A5Q2		Same as 2A4Q2	5-8
2A5Q3		Same as 2A4Q2	5-8
2A5R1		RESISTOR: MIL-type RW31V511	5-8
2A5R2		RESISTOR: MIL-type RT12C2L501	5-8
2A5R3		RESISTOR: MIL-type RC42GF561K	5-8
2A5R4		Same as 2A5R3	5-8
2A5R5		Same as 2A5R3	5-8
2A5R6		Same as 2A5R3	5-8
2A5T1		TRANSFORMER, POWER: 47.5 to 63 cps, 535 peak working volts; Triad Transformer Corp part 68172; Hoffman part 818000057	5-8

TABLE 6-2. TRANSMITTER GROUP AN/WRA-3
MAINTENANCE PARTS LIST (Continued)

POWER SUPPLY, +28 VDC

REF. DESIG.	NOTES	NAME AND DESCRIPTION	FIG. NO.
UNIT 2 ASSY 6		POWER SUPPLY, +28 VDC: 2 amps, 115 v 60 cps input, output voltage ± 1 v of nominal value with input of 115 v $\pm 10\%$, 47.5 to 63 cps, output load of 0 to 2 amp; ripple plus noise max 100 mv rms; Hoffman part 8021100080-2	5-1
2A6C1		Same as 2A5C1	5-9
2A6C2		Same as 2A4C1	5-9
2A6C3		Same as 2A4C1	5-9
2A6C4		Same as 2A4C7	5-9
2A6C5		CAPACITOR: MIL-type CL65BK040MP3	5-9
2A6CR1		Same as 2A5CR1	5-9
2A6CR2		Same as 2A5CR1	5-9
2A6CR3		Same as 2A5CR1	5-9
2A6CR4		Same as 2A5CR4	5-9
2A6J1		Same as 2A2J2	5-9
2A6J2		Same as 2A1J2	5-9
2A6Q1		Same as 2A4Q1	5-9
2A6Q2		Same as 2A4Q2	5-9
2A6Q3		Same as 2A4Q2	5-9
2A6R1		Same as 2A5R1	5-9
2A6R2		Same as 2A5R2	5-9
2A6R3		Same as 2A5R3	5-9
2A6R4		Same as 2A5R3	5-9
2A6R5		Same as 2A5R3	5-9
2A6T1		Same as 2A5T1	5-9

TABLE 6-2. TRANSMITTER GROUP AN/WRA-3
MAINTENANCE PARTS LIST (Continued)

POWER SUPPLY, TERMINAL BOARD ASSEMBLIES

REF. DESIG.	NOTES	NAME AND DESCRIPTION	FIG. NO.
2TB7		TERMINAL BOARD: Mounting board assembly for Bias Supply, consisting of Hoffman part 8031100773 with 13 CTC 1280B-6 terminals and 1 Augat Bros, 6003-8CC component clip	5-3, Sheet 3
2C5		CAPACITOR: MIL-type CH05A1NF103K	
2CR1		SEMICONDUCTOR DEVICE, DIODE: MIL-type 1N3031B	
2CR2		SEMICONDUCTOR DEVICE, DIODE: MIL-type 1N3025B	
2L1		CHOKES, RADIO FREQUENCY: MIL-type LT4K073; MS75055-5	
2R3		RESISTOR: MIL-type RW55G470	
2R5		RESISTOR: MIL-type RC32GF680K	
2R6		RESISTOR: MIL-type RC20GF102K	
2R7		RESISTOR: MIL-type RC20GF101K	
2R8		RESISTOR: MIL-type RL20AD102J	5-3, Sheet 3
2A3TB1		TERMINAL BOARD: Mounting board assembly for Bias Supply, consisting of Hoffman part 8031100772 with 5 CTC 1280B-6 terminals	5-6
2A3C1		CAPACITOR: MIL-type CL14CK800UP3	
2A3CR1		SEMICONDUCTOR DEVICE, DIODE: MIL-type 1N277	
2A3CR2		Same as 2A3CR1	
2A3CR3		Same as 2A3CR1	
2A3CR4		Same as 2A3CR1	

TABLE 6-2. TRANSMITTER GROUP AN/WRA-3
MAINTENANCE PARTS LIST (Continued)

ELECTRICAL EQUIPMENT CABINET CY-3022/WRA-3, UNIT 3

REF. DESIG.	NOTES	NAME AND DESCRIPTION	FIG. NO.
UNIT 3		ELECTRICAL EQUIPMENT CABINET: 22-1/4 in. w, 23-1/4 in. deep, 37 in. high; Hoffman part 8020000118-1	5-11
3B1		BLOWER: Squirrel cage, cw; Rotron Model DRPP1, type KS505-CW, series 329ADA frame; Hoffman part 8180000068	5-11
3B2		BLOWER: Squirrel cage, ccw; Rotron Model DRPP1, type KS505-CCW, series 329ADA frame; Hoffman part 8180000067	5-11
3C1		CAPACITOR: MIL-type CH53B1NF405K	5-11
3C2		Same as 3C1	5-11
3C3		CAPACITOR, FIXED, PAPER DIELECTRIC: 0.22 uf, 1250 vdc working; Sprague part 99JX36; Hoffman part 1079901508	5-11
3C4		CAPACITOR: MIL-type CZ24BEE104	5-11
3C5		Same as 3C4	5-11
3C6		Same as 3C4	5-11
3C7		Same as 3C4	5-11
3C8		Same as 3C4	5-11
3C9		Same as 3C4	5-11
3C10		Same as 3C4	5-11
3C11		Same as 3C4	5-11
3C12		Not used	
3C13		CAPACITOR: MIL-type CZ24BEF103	5-11
3C14		Same as 3C13	5-11
3CR1		SEMICONDUCTOR DEVICE, DIODE: MIL-type 1N547	5-11
3E1		TERMINAL FEEDTHRU, INSULATED: MIL-type FT01-02	5-11
3E2		Same as 3E1	5-11
3F1		FUSE: MIL-type F03G12R0B, MS90079-25-1 for 115 v, operation; replace with MIL-type F03G6R00A; MS 90078-15-1 for 230 v operation	5-11
3F2		Same as 3F1	5-11
3FL1		LINE FILTER: Low pass, 115 v rms, 60 cps at 20 amp, 230 vrms, 60 cps at 10 amp, 100 db attenuation between 0.1 mc and 1000 mc; Cornell Dublier Elect. Div. part NF20427-1; Hoffman part 8180000051	5-11

TABLE 6-2. TRANSMITTER GROUP AN/WRA-3
MAINTENANCE PARTS LIST (Continued)

ELECTRICAL EQUIPMENT CABINET CY-3022/WRA-3, UNIT 3

REF. DESIG.	NOTES	NAME AND DESCRIPTION	FIG. NO.
3J1		ADAPTER, CONNECTOR: BNC series UG-492C/U, MIL-type MS35177-492D	5-11
3J2		CONNECTOR, RECEPTACLE, ELECTRICAL: Straight adapter, two female ends, IPC part 12650; Hoffman part 1199900609	5-11
3J3		Same as 3J1	5-11
3J4		Same as 3J1	5-11
3J5		Same as 3J1	5-11
3MP1		FILTER, AIR: Aluminum alloy screen and frame, Hoffman part 8180000061	5-11
3MP2		Same as 3MP1	5-11
3P1		Not used	
3P2		CONNECTOR, PLUG, ELECTRICAL: BNC series UG88E/U; MIL-type MS35168-88E	5-11
3P3		CONNECTOR, PLUG, ELECTRICAL: BNC 5000V; Dage part 4934-1; Hoffman part 1199900608	5-11
3P4		Same as 3P3	5-11
3P5		CONNECTOR, PLUG, ELECTRICAL: Subminiature for RG188/U cable; Sealectro part 3000; Hoffman part 1199900611	5-11
3P6		CONNECTOR, PLUG, ELECTRICAL: Adapter for RG188/U cable to BNC connector mating end; Dage part 1-150-4; Hoffman part 1199900589	5-11
3P7		Same as 3P6	5-11
3P8		Same as 3P6	5-11
3P9		Same as 3P6	5-11
3P10		Same as 3P6	5-11
3P11		Same as 3P6	5-11
3P12		Same as 3P6	5-11
3P13		Same as 3P2	5-11
3P14		Same as 3P2	5-11
3P15		Same as 3P2	5-11
3P16		Same as 3P6	5-11
3P17		Not used	

TABLE 6-2. TRANSMITTER GROUP AN/WRA-3
MAINTENANCE PARTS LIST (Continued)

ELECTRICAL EQUIPMENT CABINET CY-3022/WRA-3, UNIT 3

REF. DESIG.	NOTES	NAME AND DESCRIPTION	FIG. NO.
3P18		Not used	
3P19		Same as 3P5	5-11
3P20		Same as 3P3	5-11
3P21		Same as 3P3	5-11
3P22		CONNECTOR, PLUG, ELECTRICAL: MIL-type MS3106R10SL-3S	5-11
3S1		SWITCH, TOGGLE: DPST, MIL-type MS35059-22	5-11
3T1		TRANSFORMER, POWER, FIXED: Single autoformer winding. Input taps for 115 vrms and 230 vrms. Output tap 115 vrms at 13 amp, U.T.C. Pac. Div. part PA-5276A; Hoffman part 818000010	5-11
3TB1		TERMINAL BOARD: MIL-type 5TB8	5-11
3TB2		TERMINAL BOARD: MIL-type 8TB6	5-11
3TB3		Same as 2TB5	5-11
3TB4		TERMINAL BOARD: MIL-type 7TB12	5-11
3TB5		TERMINAL BOARD: MIL-type 8TB10	5-11
3TB6		TERMINAL BOARD: MIL-type 8TB8	5-11
3TB7		Same as 3TB5	5-11
3TB8		Same as 3TB6	5-11
3TB9		Same as 3TB6	5-11
3TB10		TERMINAL BOARD ASSY: Hoffman part 8030000036-1	5-11
3XF1		FUSEHOLDER: MIL-type FHL10G	5-11
3TB10		TERMINAL BOARD ASSY: Mounting board assembly consisting of Hoffman part 8080000589 with 2 CTC 1280B-6 terminals	5-11
3CR1		SEMICONDUCTOR DEVICE, DIODE: MIL-type 1N547	5-11
			5-11

TABLE 6-2. TRANSMITTER GROUP AN/WRA-3
MAINTENANCE PARTS LIST (Continued)

INTERCONNECTING UNIT MX-3645/WRA-3, UNIT 4

REF. DESIG.	NOTES	NAME AND DESCRIPTION	FIG. NO.
UNIT 4		INTERCONNECTING UNIT: 19 in. lg, 6.968 in. high, 19.25 in. deep; Hoffman part 8021000164	5-12
E1		TERMINAL, STUD: USECO part 1300T-6; Hoffman part 2099900438	5-12
4J1		CONNECTOR, RECEPTACLE, ELECTRICAL: 50 ohms impedance; Sealectro part 3002; Hoffman part 1199900612	5-12
4J2		Same as 4J1	5-12
4R1		RESISTOR: MIL-type RC20GF470K	5-12
4R2		Same as 4R1	5-12
4TB1		TERMINAL BOARD: MIL-type 11TB9	5-12
4TB2		Same as 4TB1	5-12
ELECTRICAL FREQUENCY SYNTHESIZER O-1115/URC			
UNIT 5	1	ELECTRICAL FREQUENCY SYNTHESIZER O-1115/URC	
RELAY ASSEMBLY RE-754/WRT-4, UNIT 7			
UNIT 7	2	RELAY ASSEMBLY: Coaxial relay unit, over-all dimensions 3-3/4 in. high, 5-1/8 in. wide, 6-1/2 in. deep; DPDT, 24 vdc $\pm 10\%$, 50 ohms impedance, 2 KW CW average, 5 KW peak, 15 milliseconds typical transfer time, 20 milliseconds maximum; mating "Power In" connector MIL-type 10-109611-4S included; Jennings part RC45E6101X44; Hoffman part 8030000241-5	2-1

TABLE 6-3. MODIFICATION KIT MK-846/WRA-3
MAINTENANCE PARTS LIST

REF. DESIG.	NOTES	NAME AND DESCRIPTION	*FIG. NO.
C1A	2	CAPACITOR: MIL-type CY10C5R1C	
C1B	2	CAPACITOR: MIL-type CM15C330JN3	
CP1	2	COAXIAL ADAPTER: MIL-type UG274B/U; MS35173-274B	
CP2	2	COAXIAL ADAPTER: MIL-type UG-306B/U; MS35173-306B	
E1	2	COAXIAL TERMINATION ASSY: Consisting of MIL-type connector MS35168-88E and MIL-type resistor RC42GF470K; Hoffman part 8030000167	
E2	2	TERMINAL LUG: Stud size #5, #22-16 AWG wire, copper electro tinned, vinyl insulation; AMP part 327950; Hoffman part 2099900424	
E3	2	Same as E2	
E4	2	Same as E2	
E5	2	Same as E2	
E6	2	Same as E2	
E7	2	Same as E2	
E8	2	Same as E2	
E9	2	Same as E2	
E10	2	Same as E2	
E11	2	Same as E2	
E12	2	Same as E2	
E13	2	TERMINAL LUG: Stud size #6, 22-16 AWG wire, copper electro tinned, vinyl insulation; AMP part 327938; Hoffman part 2099900421	
E14	2	Same as E13	
E15	2	Same as E13	
E16	2	Same as E13	
E17	2	Same as E13	
E18	2	Same as E13	
J5	2	CONNECTOR, RECEPTACLE, ELECTRICAL: Beryllium copper contacts, teflon insulators; Aviel part 02-629; Hoffman part 1199900656	

* Not applicable.

TABLE 6-3. MODIFICATION KIT MK-846/WRA-3
MAINTENANCE PARTS LIST (Continued)

REF. DESIG.	NOTES	NAME AND DESCRIPTION	*FIG. NO.
K1	2	COAXIAL RELAY: SPDT, hermetically sealed remote operation, 3 BNC-type connectors, 26 vdc, 280 ohms, 10 millisecc operating time; Amphenol-Borg part 346-010025-3; Hoffman part 2039900134	
P1	2	CONNECTOR, PLUG, ELECTRICAL: MIL-type 10-109618-1S	
P2	2	CONNECTOR, PLUG, ELECTRICAL: MIL-type MS35168-88E	
P3	2	Same as P2	
P4	2	Same as P2	
P5	2	Same as P2	
P6	2	Same as P2	
P7	2	Same as P2	
P8	2	CONNECTOR, PLUG, ELECTRICAL: Brass, silver plate, 5/8 in. dia by 15/16 in. lg; Dage part 1-150-4; Hoffman part 1199900589	
P9	2	CONNECTOR, PLUG, ELECTRICAL: Brass, silver plate, 1/2 in. dia by 1 in. lg; Dage part 4982-2; Hoffman part 1199900738	
TB1	2	TERMINAL BOARD: MIL-type 8TB8	

* Not applicable.

TABLE 6-3. MODIFICATION KIT MK-846/WRA-3
MAINTENANCE PARTS LIST (Continued)

TRANSMITTER TRANSFER CONTROL C-6562/WRA-3, UNIT 6

REF. DESIG.	NOTES	NAME AND DESCRIPTION	*FIG. NO.
UNIT 6	2	TRANSMITTER TRANSFER CONTROL: Hoffman part 8020000154-1	
6E1	2	TERMINAL STUD, INSULATED: MIL-type SE19-1	
6E2	2	Same as 6E1	
6E3	2	TERMINAL LUG: 0.375 hole size, copper, hot tinned; Zierick part 334; Hoffman part 2099900159	
6E4	2	TERMINAL LUG: Brass, hot tinned; Zierick part 9-4; Hoffman part 2091000008	
6J1	2	CONNECTOR, RECEPTACLE, ELECTRICAL: MIL-type MS3102R18-1P	
6J2	2	CONNECTOR, RECEPTACLE, ELECTRICAL: MIL-type MS27035-625B	
6J3	2	Same as 6J2	
6J4	2	Same as 6J2	
6MP1	2	KNOB: MIL-type MS91528-2K2B	
6R1	2	RESISTOR: MIL-type RC42GF221K	
6R2	2	Same as 6R1	
6R3	2	RESISTOR: MIL-type RC42GF680K	
6R4	2	RESISTOR: MIL-type RC42GF101K	
6R5	2	RESISTOR: MIL-type RC42GF470K	
6S1A	2	ROTARY SWITCH: One section, hardware supplied; Hoffman part 8050001679	
6S1B	2	WAFER SWITCH: Hoffman part 8180000150	

TABLE 6-4. TRANSMITTER GROUP AN/WRA-3,
LIST OF MANUFACTURERS

ABBREVIATION	NAME	ADDRESS
Allen-Bradley	Allen-Bradley Co.	Milwaukee, Wis.
AMP	AMP, Inc.	Harrisburg, Pa.
Augat	Augat Bros., Inc.	Attleboro, Mass.
Automatic Metals Products	Automatic Metals Products Co.	Brooklyn, N.Y.
Aviel	Aviel Electronics Inc.	Venice, Calif.
Birnbach	Birnbach Radio Co.	New York, N.Y.
Boston Gear	Boston Gear Works	Boston, Mass.
Bourns	Bourns Laboratories, Inc.	Riverside, Calif.
Centralab	Centralab (Div. of Globe Union, Inc.)	Milwaukee, Wis.
CGS Labs	CGS Laboratories, Inc.	Stamford, Conn.
Circon	Circon Components	Goleta, Calif.
Control Switch	Control Switch (Div. of Controls Co. of America)	Folcroft, Pa.
Cornell Dubilier Elec. Div.	Cornell Dubilier Electric Corp. (Electronic Div.)	Indianapolis, Ind.
CTC	Cambridge Thermionic	Cambridge, Mass.
Dage	Dage Electric Co.	Beech Grove, Ind.
Dale Products	Dale Products, Inc. (Pacific Div.)	Burbank, Calif.
Dynaco	Dynamics Gear Co.	Amityville, N.Y.
E. F. Johnson	E. F. Johnson Co.	Waseca, Minn.
Eimac	Eital-McCullough, Inc.	San Carlos, Calif.
Falcon Machine	Falcon Machine and Tool Co.	Cambridge, Mass.
Haydon Div., General Time	Haydon Mfg. Co. (Div. of General Time Instruments Corp.)	Forestville, Conn.
Hoffman	Hoffman Military Products (Div. of Hoffman Electronics Corp.)	El Monte, Calif.
IPC (Amphenol-Borg)	Industrial Products Co. (Div. of Amphenol-Borg Electronic Corp.)	Danbury, Conn.
Jennings	Jennings Radio	San Jose, Calif.
JFD	JFD Electronics Corp.	Brooklyn, N.Y.

TABLE 6-4. TRANSMITTER GROUP AN/WRA-3,
LIST OF MANUFACTURERS (Continued)

ABBREVIATION	NAME	ADDRESS
Leach	Leach Relay Co.	Los Angeles, Calif.
Mallory	Mallory Electric Corp.	Detroit, Mich.
Microphase Corp.	Microphase Corp.	Greenwich, Conn.
Micro Switch	Micro Switch Corp. (Div. of First Industrial Corp.)	Freeport, Ill.
Millen	James Millen Mfg. Co., Inc.	Malden, Mass.
NMC	Nylon Moulding Corp.	Garwood, N.J.
PIC	PIC Design Corp.	East Rockaway, N.Y.
Radio Condenser	Radio Condenser Co.	Camden, N.J.
Raytheon	Raytheon Mfg. Co.	Waltham, Mass.
Rotron	Rotron Mfg. Co., Inc.	Woodstock, N.Y.
Rubbercraft	Rubbercraft Corp. of California, Ltd.	Torrance, Calif.
Seaelectro	Seaelectro Corp.	New Rochelle, N.Y.
Sprague	Sprague Electric Co.	North Adams, Mass.
Thos. A. Edison	Thos. A. Edison Industries (Div. of McGraw-Edison Co.)	West Orange, N.J.
Triad	Triad Transformer Corp.	Venice, Calif.
USECO	U.S. Engineering Co.	Glendale, Calif.
U.T.C. Pac. Div.	United Transformer Co. (Pacific Div.)	Los Angeles, Calif.
Voland	Voland and Sons	New Rochelle, N.Y.
Waldes Kohinoor	Waldes Kohinoor, Inc.	Long Island City, N.Y.
Zierick	Zierick Mfg. Co.	New Rochelle, N.Y.

INDEX

	Paragraph (Figure) *Table	Paragraph (Figure) *Table
A		
Adjustment:		
Electrical Frequency Synthesizer . . .	3-2b(2)(a)	
Power Supply PP-2796/WRA-3 . . .	5-3d(1)	
Radio Frequency Amplifier		
AM-2819/WRA-3	5-3d(2)	
Radio Set AN/URC-32	3-2b(2)(c)	
Radio Transmitting Set AN/WRT-2 . . .	3-2b(2)(b)	
Adjustments:		
installation	2-6c	
operating checks	3-5a	
tuning	5-3	
Antennas, characteristics of		
recommended	1-4g	
B		
Block diagrams:		
functional	(4-1)	
servicing	(4-2), (4-3)	
C		
Characteristics:		
power supply	1-4i	
recommended antennas	1-4g	
Controls, description of	3-2a	
Controls and indicators:		
Electrical Equipment Cabinet		
CY-3022/WRA-3	*3-4	
Electrical Frequency Synthesizer		
O-1115/URC	*3-1	
Power Supply PP-2796/WRA-3 . . .	*3-3	
Radio Frequency Amplifier		
AM-2819/WRA-3	*3-2	
D		
Description:		
controls	3-2a	
functional section	4-3	
over-all functional	4-2	
power supply functional section . . .	4-3e	
radio frequency amplifier		
functional section	4-3g	
synthesizer functional section . . .	4-3c	
units	1-3	
Diagrams:		
equipment schematic . . . (5-14), (5-15), (5-16), (5-17), (5 18)		
Diagrams: (Cont)		
power schematic	(5-13)	
servicing block	(4-2), (4-3)	
simplified schematic	(4-4)	
unit interconnection	(2-6)	
Dismantling	2-4b	
E		
Electrical Equipment Cabinet		
CY-3022/WRA-3		
controls and indicators	*3-4	
removal of parts	5-4d	
Electrical Frequency Synthesizer		
O-1115/URC		
adjustments	3-2b(2)(a)	
controls and indicators	*3-1	
Electrical input and output data . . .	1-4f	
Emergency:		
maintenance	3-5b	
operation	3-4	
use of synthesizer	2-8	
Emission, type of	1-4c	
Energizing equipment, first time . . .	2-6b	
Equipment and publications required		
but not supplied	1-6	
Equipment similarities	1-8	
Equipment supplied	1-5	
Excitation	3-1b(1)(b)1	
F		
Factory or field changes	1-7	
Failure, performance and		
operational reports	5-1	
Frequency		
control, type of	1-4b	
range	1-4a	
stability	1-4e	
Functional block diagrams,		
equipment (4-1), (4-2), (4-3)		
Functional operation of Transmitter		
Group AN/WRA-3	3-1	
Functional section test data	4-3d, 4-3f, 4-3h	
H		
Handling and unpacking	2-1	

INDEX (Cont)

	Paragraph (Figure) *Table		Paragraph (Figure) *Table
Sequence of operation	3-2b	starting	3-2b(1)(c)
Standby	3-2b(3)	Trouble shooting:	
Starting:		Electrical Equipment Cabinet	
Radio Set AN/URC-32	3-2b(1)(e)	CY-3022/WRA-3	4-3j(4)(c)
Radio Transmitting Set AN/WRT-2	3-2b(1)(c)	Electrical Frequency Synthesizer	
Transmitter Group AN/WRA-3	3-2b(1)(c)	O-1115/URC (GFM)	4-3d
Summary of operating procedures	3-3	Interconnecting Unit	
Synthesizer, emergency use of	2-8	MX-3645/WRA-3	4-3j(4)(b)
		logical	4-1
T		miscellaneous	4-3i
Temperature, ambient, limitations	1-4h	Power Supply PP-2796/WRA-3	4-3f
Test data:		Radio Frequency Amplifier	
Miscellaneous	4-3j	AM-2819/WRA-3	4-3h
Power Supply functional section	4-3f	Relay Assembly RE-754/WRT-4	4-3j(4)(c)
Radio Frequency Amplifier		Resilient Mount MT-2661/WRA-3	4-3j(4)(e)
functional section	4-3h	Tuning and adjustment	5-3
Synthesizer functional section	4-3d		
Transmission, direct	3-1b(1)(b)1	U	
Transmitter Group AN/WRA-3,		Unpacking and handling	2-1