

★

NAVSHIPS 92482

INSTRUCTION BOOK

for

RF SIGNAL GENERATOR SET
AN/URM-26A

MEASUREMENTS CORPORATION

BOONTON, NEW JERSEY

BUREAU OF SHIPS

NAVY DEPARTMENT

★

Contract: NObsr-52212

Approved by BuShips: 11 April 1955

LIST OF EFFECTIVE PAGES

| PAGE NUMBERS | CHANGE IN EFFECT | PAGE NUMBERS | CHANGE IN EFFECT |
|-------------------------|-----------------------------|-------------------------|-----------------------------|
| Title Page | Original | 5-0 | Original |
| A to C | Original | 6-1 | Original |
| i to v | Original | 7-0 to 7-28 | Original |
| 1-0 to 1-3 | Original | 8-0 to 8-25 | Original |
| 2-0 to 2-7 | Original | | |
| 3-0 to 3-1 | Original | | |
| 4-0 to 4-5 | Original | | |

Temporary Correction T-1 to Instruction Book for R. F. Signal Generator Set AN/URM-26A (NAVSHIPS 92482).

The corrections noted in this Temporary Correction should be marked with pen and ink on the referenced pages of the Instruction Book. This Temporary Correction should then be inserted in the front of the book as a permanent record.

| PAGE | FIGURE OR TABLE | CORRECTION |
|---|--------------------|---|
| 1-2 | 1-3 | Change number of installed Type 5814 tubes from 2 to 1. Oposite V-108 add numeral 1 in first column, and 12AU7 in second column. |
| NOTE | | |
| Tube V-108 cannot be replaced by its equivalent "reliable" type tube because of various factors affecting interchangeability. When requesting replacement, specifically state "No Substitute Acceptable." | | |
| 2-2 | 2-3 | Add reference T-101 for Power Transformer. Value of C-134 should be .5. |
| 2-3 | 2-4 | Add reference E-120 for antenna symbol adjacent to Resistor R-154. Delete connection between C-115 and L-105. Value of R-176 should be 47. |
| 2-4 | 2-5 | Add meter reference M-101. Change V-108 from Type 5814 to Type 12AU7. |
| 2-5 | 2-7 | Value of R-176 should be 47. |
| 2-6 | 2-8 | Change B+ voltage to 390. |
| 2-7 | 2-9 | Change +150 volts to +160 volts. Change value R-112 from 265K to 240K. |
| 7-3 | 7-2 | Change V-108 from Type 5814 to Type 12AU7. |
| 7-22 | 7-3 | Change Tube Type of Meter Rectifier from 5814 to 12AU7. |
| 7-22 | 7-4 | Below Tube Type 5814 add 12AU7. Tube characteristics are same as for Type 5814 except as follows: "Filament Current .30*; AC Plate Resistance 7700 ohms; Voltage Amplification Factor 17.0. |
| 7-27 | 7-21 | Mark: R-112, 240K; R-159, 4.7K. Change V-108 from Type 5814 to Type 12AU7. Interchange positions of + and - signs on Meter M-101. |
| 8-1 | 8-1 | Add the following note under description of GENERATOR SET, RF SIGNAL: "For ASO only, substitute SNSN R-16-AN-URM-26A" |

| PAGE | FIGURE OR TABLE | CORRECTION |
|------|--------------------|---|
| 8-11 | 8-1 | Change value of R-112 from 265,000 ohms to 240,000 ohms and MC Part No. from H-3669 to H-5460. |
| 8-12 | 8-1 | Opposite R-132 add description: "RESISTOR, fixed, deposited film: 265,000 ohms $\pm 2\%$; lw. Continental Carbon, Inc. Type X1; Measurements Corp. Part H-3669." Change description of R-133 to read: "Same as R-132." |
| 8-13 | 8-1 | Change description of R-159 to read: "RESISTOR, fixed, composition: 4700 ohms $\pm 10\%$, 1/2w; JAN-R-11 Type RC20BF472K." |
| 8-14 | 8-1 | Type number for S-101 is ST52N. |
| 8-16 | 8-1 | Change description of V-108 to read: "ELECTRON TUBE: double triode; JAN Type 12AU7." Under description for W-104 change 9" to 12" and 8" to 11". |
| 8-18 | 8-2 | Below H-125 add H-127, SNSN N16-P-403502-351. |
| 8-19 | 8-2 | For J-101, SNSN is N17-C-73139-7637. For L-111, SNSN is N16-C-72573-7424. |
| 8-20 | 8-2 | For P-101, SNSN is N17-C-71463-4133. For R-111, SNSN is N16-R-73293-6791. Delete original SNSN for R-112 and replace with N16-R-73226-6178. Below R-130 add R-132, SNSN N16-R-55235-776. Below R-152 add R-159, SNSN N16-R-50129-811. |
| 8-21 | 8-2 | For XE-102, SNSN is N17-L-51688-1074. Delete W-104, W-105, and W-107. Below V-104, add V-108, SNSN N16-T-58241. |
| 8-23 | 8-3 | Below SNSN N16-R-49922-811 add N16-R-50129-811, R-159. Below SNSN N16-R-66397-4791 add N16-R-73226-6178, R-112. Opposite SNSN N16-R-55235-776 change R-112 to R-132. Below SNSN N16-T-56840-60 add N16-T-58241, V-108. |
| 7-10 | | Paragraph 7a(5), delete sentence, "If sub-assembly for band A, band E, or band F is to be removed, it is also necessary to unsolder the shield where it is attached to the neighboring sub-assembly." |
| 7-12 | 7-11 | Delete notes: "SHIELDS SOLDERED HERE." These shields are not used in production equipment. |

DEPARTMENT OF THE NAVY
BUREAU OF SHIPS
WASHINGTON 25, D. C.

IN REPLY REFER TO

Code 993-100
11 April 1955

From: Chief, Bureau of Ships
To: All Activities Concerned with the
Installation, Operation and Main-
tenance of the Subject Equipment

Subj: Instruction Book for R.F. Signal
Generator Set AN/URM-26A, NAVSHIPS
92482

1. This is the instruction book for the subject equipment and is in effect upon receipt.
2. When superseded by a later edition, this publication shall be destroyed.
3. Extracts from this publication may be made to facilitate the preparation of other Department of Defense Publications.
4. All Navy requests for NAVSHIPS Electronics publications should be directed to the nearest District Publications and Printing Office. When changes or revised books are distributed, notice will be included in the Electronics Information Bulletin, NAVSHIPS 900,022(A) and in the Index of Bureau of Ships General and Electronics Publications, NAVSHIPS 250-020.

A. G. MUMMA
Chief of Bureau

TABLE OF CONTENTS

| SECTION 1—GENERAL DESCRIPTION | | SECTION 6—PREVENTIVE MAINTENANCE | |
|--|-------------|---|-------------|
| <i>Paragraph</i> | <i>Page</i> | <i>Paragraph</i> | <i>Page</i> |
| 1. Instruction Book Coverage | 1-1 | 1. Routine Maintenance | 6-1 |
| 2. Purpose and Basic Principles | 1-1 | 2. Retropicalization | 6-1 |
| 3. Major Unit | 1-1 | 3. Lubrication | 6-1 |
| 4. Reference Data | 1-1 | | |
| SECTION 2—THEORY OF OPERATION | | SECTION 7—CORRECTIVE MAINTENANCE | |
| 1. General Description of Circuits | 2-0 | 1. Trouble Shooting and Repair | 7-1 |
| 2. Power Supply | 2-0 | 2. Plate Voltage Adjustment | 7-1 |
| 3. Radio Frequency Oscillator | 2-3 | 3. Output Meter Zero Adjustment | 7-5 |
| 4. Output System | 2-3 | 4. Output Meter Calibration | 7-5 |
| 5. Audio Oscillator | 2-5 | 5. Calibration of Percentage Modulation and Zero Set | 7-6 |
| 6. Modulator and Modulation Monitor | 2-6 | 6. Checking Frequency Calibration | 7-8 |
| 7. External Modulation | 2-7 | 7. Replacement of Oscillator Coil Sub-Assembly | 7-10 |
| 8. Pulse Modulation | 2-7 | 8. Replacing Bolometer Assembly | 7-12 |
| 9. Standby Heater | 2-7 | 9. Replacing Filter Coils L-105 through L-110 | 7-14 |
| SECTION 3—INSTALLATION | | 10. Replacing Attenuator Components | 7-14 |
| 1. Unpacking | 3-1 | 11. Replacing Tuning Capacitor | 7-15 |
| 2. Installation | 3-1 | 12. Frequency Recalibration | 7-15 |
| 3. Initial Adjustments | 3-1 | 13. Replacing Attenuator Drive Cable | 7-16 |
| SECTION 4—OPERATION | | 14. Replacement of Oscillator Tube | 7-17 |
| 1. Functions of Panel Controls | 4-1 | 15. Repair of Bolometer Filter | 7-17 |
| 2. Preliminary Adjustments | 4-1 | 16. Repair of Oscillator Heater Filter | 7-18 |
| 3. Connections to Equipment Under Test .. | 4-1 | 17. Repair of Oscillator Plate Supply Filter .. | 7-18 |
| 4. Connections to Auxiliary Equipment | 4-3 | 18. Replacement of Coil L-113 | 7-18 |
| 5. Measurement of Receiver Sensitivity | 4-4 | 19. Replacing Resistors in Fixed Attenuator CN-179/URM-26A | 7-18 |
| 6. Measurement of Receiver Selectivity | 4-4 | 20. Replacing Resistors in Test Adapter MX-1289/URM-26A | 7-20 |
| 7. Determining Signal-to-Noise Ratio | 4-4 | | |
| 8. Determining Image Ratios | 4-5 | | |
| SECTION 5—OPERATOR'S MAINTENANCE | | SECTION 8—PARTS LISTS | |
| 1. Emergency Maintenance | 5-0 | | |

LIST OF ILLUSTRATIONS

| SECTION 1—GENERAL DESCRIPTION | | <i>Figure</i> | <i>Page</i> |
|--------------------------------------|--|---|---|
| <i>Figure</i> | <i>Page</i> | 4-4 | Pulse Output Correction 4-3 |
| 1-1 | RF Signal Generator Set AN/URM-26A | 4-5 | Typical Set-up for Receiver Measure- ments 4-4 |
| | | | |
| SECTION 2—THEORY OF OPERATION | | SECTION 5—OPERATOR'S MAINTENANCE | |
| 2-1 | RF Signal Generator SG-45A/URM-26, Functional Block Diagram | 5-1 | RF Signal Generator SG-45A/URM-26, Tube Locations 5-0 |
| 2-2 | RF Signal Generator SG-45A/URM-26, Interior | SECTION 6—PREVENTIVE MAINTENANCE | |
| 2-3 | RF Signal Generator SG-45A/URM-26, Functional Schem- atic Diagram, Power Supply | SECTION 7—CORRECTIVE MAINTENANCE | |
| 2-4 | RF Signal Generator SG-45A/URM-26, Functional Schem- atic Diagram, RF Oscillator | 7-1 | Voltage, Resistance and Parts Location of Terminal Boards 7-2 |
| 2-5 | RF Signal Generator SG-45A/URM-26, Functional Schem- atic Diagram, RF Monitor | 7-2 | Tube Socket Voltage and Resistance Data 7-3 |
| 2-6 | Simplified Schematic Diagram, Meter Balancing Circuit | 7-3 | RF Signal Generator SG-45A/URM-26, Rear View 7-4 |
| 2-7 | RF Signal Generator SG-45A/URM-26, Functional Schem- atic Diagram, Output System | 7-4 | RF Signal Generator SG-45A/URM-26, Side View 7-5 |
| 2-8 | RF Signal Generator SG-45A/URM-26, Functional Schem- atic Diagram, AF Oscillator | 7-5 | RF Signal Generator SG-45A/URM-26, Top View 7-6 |
| 2-9 | RF Signal Generator SG-45A/URM-26, Functional Schem- atic Diagram, Modulator and Modu- lation Monitor | 7-6 | RF Signal Generator SG-45A/URM-26, Power Supply 7-7 |
| | | 7-7 | RF Signal Generator SG-45A/URM-26, Connections for Measuring Output Voltage 7-8 |
| SECTION 3—INSTALLATION | | 7-8 | RF Signal Generator SG-45A/URM-26, Connections for Checking Frequency Calibration 7-8 |
| 3-1 | RF Signal Generator Set AN/URM-26A, Typical Packaging | 7-9 | RF Signal Generator SG-45A/URM-26, Partial Disassembly, Front Panel 7-9 |
| 3-2 | RF Signal Generator Set AN/URM-26A, Outline Dimensional Drawing | 7-10 | RF Signal Generator SG-45A/URM-26, Oscillator Compart- ment, Interior 7-11 |
| | | 7-11 | RF Signal Generator SG-45A/URM-26, Coil Disc Assembly 7-12 |
| SECTION 4—OPERATION | | 7-12 | RF Signal Generator SG-45A/URM-26, Oscillator Compart- ment showing Bolometer 7-13 |
| 4-1 | RF Signal Generator SG-45A/URM-26, Front Panel Dia- gram | 7-13 | RF Signal Generator SG-45A/URM-26, RF Attenuator 7-15 |
| 4-2 | RF Signal Generator Set AN/URM-26A, Cording Diagram | 7-14 | RF Signal Generator SG-45A/URM-26, Tuning Capacitor Mounting 7-16 |
| 4-3 | RF Signal Generator SG-45A/URM-26, Diagram for External Modulation | 7-15 | RF Signal Generator SG-45A/URM-26, Recalibration Set- up 7-17 |

| | | | |
|---|------|---|------|
| 7-16 RF Signal Generator SG-45A/URM-26, Typical Dial Cali bration | 7-17 | 7-19 Methods of Assembling Cord and Cable | 7-21 |
| 7-17 RF Signal Generator SG-45A/URM-26, RF Filters | 7-19 | 7-20 RF Signal Generator SG-45A/URM-26 Wiring Diagram, Interconnection, Power Supply to Panel Assembly | 7-26 |
| 7-18 Fixed Attenuator CN-179/URM-26A and Test Adapter MX-1289/URM-26A | 7-20 | 7-21 RF Signal Generator Set AN/URM-26A, Schematic Diagram .. | 7-27 |

LIST OF TABLES

SECTION 1—GENERAL DESCRIPTION

| <i>Table</i> | | <i>Page</i> |
|--------------|--------------------------------|-------------|
| 1-1 | Equipment Supplied | 1-1 |
| 1-2 | Shipping Data | 1-2 |
| 1-3 | Electron Tube Complement | 1-2 |
| 1-4 | Lamp Complement | 1-3 |
| 1-5 | Cross Reference—Tubes | 1-3 |

SECTION 2—THEORY OF OPERATION

SECTION 3—INSTALLATION

SECTION 4—OPERATION

SECTION 5—OPERATOR'S MAINTENANCE

SECTION 6—PREVENTIVE MAINTENANCE

| <i>Table</i> | | <i>Page</i> |
|--------------|-------------------------------------|-------------|
| 6-1 | Routine Maintenance Check Chart ... | 6-1 |

SECTION 7—CORRECTIVE MAINTENANCE

| | | |
|-----|--------------------------------------|------|
| 7-1 | Trouble Shooting Chart | 7-0 |
| 7-2 | Test Equipment For Maintenance Use | 7-1 |
| 7-3 | Tube Operating Voltages and Currents | 7-22 |
| 7-4 | Tube Characteristics | 7-22 |
| 7-5 | Winding Data | 7-23 |

SECTION 8—PARTS LIST

| | | |
|-----|------------------------------------|------|
| 8-1 | Maintenance Parts List | 8-1 |
| 8-2 | Stock Number Identification | 8-18 |
| 8-3 | Stock Number Cross Reference | 8-22 |
| 8-4 | List of Manufacturers | 8-25 |

GUARANTEE

The equipment, including all parts and spare parts, except vacuum tubes, batteries, rubber and material normally consumed in operation, is guaranteed for a period of one year from the date of delivery of the equipment to and acceptance by the Government with the understanding that all such items found to be defective as to material, workmanship or manufacture will be repaired or replaced, f.o.b. any point within the continental limits of the United States designated by the Government, without delay and at no expense to the Government; provided that such guarantee will not obligate the Contractor to make repair or replacement of any such defective items unless the defect appears within the aforementioned period and the Contractor is notified thereof in writing within a reasonable time and the defect is not the result of normal expected shelf life deterioration.

To the extent the equipment, including all parts and spare parts, as defined above, is of the Contractor's design or is of a design selected by the Contractor, it is also guaranteed, subject to the foregoing conditions, against defects in design with the understanding that if ten percent (10%) or more of any such said item, but not less than two of any such item, of the total quantity comprising such items furnished under the contract, are found to be defective as to design, such item will be conclusively presumed to be of defective design and subject to one hundred percent (100%) correction or replacement by a suitably redesigned item.

All such defective items will be subject to ultimate return to the Contractor. In view of the fact that normal activities of the Naval Service may result in the use of equipment in such remote portions of the world or under such conditions as to preclude the return of the defective items for repair or replacement without jeopardizing the integrity of Naval communications, the exigencies of the Service, therefore, may necessitate expeditious repair of such items in order to prevent extended interruption of communications. In such cases the return of the defective items for examination by the Contractor prior to repair or replacement will not be mandatory. The report of a responsible authority, including details of the conditions surrounding the failure, will be acceptable as a basis for affecting expeditious adjustment under the provisions of this contractual guarantee.

The above one year period will not include any portion of time the equipment fails to perform satisfactorily due to any defects, and any items repaired or replaced by the Contractor will be guaranteed anew under this provision.

INSTALLATION RECORD

| | |
|---|-----------------------------------|
| Contract Number NObsr-52212 | Date of Contract, 10 January 1951 |
| <i>Serial Number of equipment</i> | |
| <i>Date of acceptance by the Navy</i> | |
| <i>Date of delivery to contract destination</i> | |
| <i>Date of completion of installation</i> | |
| <i>Date placed in service</i> | |

Blank spaces on this page shall be filled in at time of installation.

REPORT OF FAILURE

Report of failure of any part of this equipment, during its entire service life, shall be made to the Bureau of Ships in accordance with current regulations using form NAVSHIPS NBS 383 (revised) except for Marine Corps equipment, in which case the "Signal Equipment Failure Report" form shall be used and distributed in accordance with instructions pertaining thereto. The report shall cover all details of the failure and give the date of installation of the equipment. For procedure in reporting failures see Chapter 67 of the *Bureau of Ships Manual* or superseding instructions.

ORDERING PARTS

All requests or requisitions for replacement material should include the following data:

1. Federal stock number or, when ordering from a Marine Corps or Signal Corps supply depot, the Signal Corps stock number.
2. Name and short description of part.

If the appropriate stock number is not available the following shall be specified:

1. Equipment model or type designation, circuit symbol, and item number.
2. Name of part and complete description.
3. Manufacturer's designation.
4. Contractor's drawing and part number.
5. JAN or Navy type number.

SAFETY NOTICE

The attention of officers and operating personnel is directed to Chapter 67 of the *Bureau of Ships Manual* or superseding instructions on the subject of radio-safety precautions to be observed.

This equipment employs voltages which are dangerous and may be fatal if contacted by operating personnel. Extreme caution should be exercised when working with the equipment.

While every practicable safety precaution has been incorporated in this equipment, the following rules must be strictly observed:

KEEP AWAY FROM LIVE CIRCUITS:

Operating personnel must at all times observe all safety regulations. Do not change tubes or make adjustments inside equipment with high voltage supply on. Under certain conditions dangerous potentials may exist in circuits with power controls in the off position due to charges retained by capacitors.

To avoid casualties always remove power and discharge and ground circuits prior to touching them.

DON'T SERVICE OR ADJUST ALONE:

Under no circumstances should any person reach within or enter the enclosure for the purpose of servicing or adjusting the equipment without the immediate presence or assistance of another person capable of rendering aid.

DON'T TAMPER WITH INTERLOCKS:

Do not depend upon door switches or interlocks for protection but always shut down motor generators or other power equipment. Under no circumstances should any access gate, door, or safety interlock switch be removed, short-circuited, or tampered with in any way, by other than authorized maintenance personnel, nor should reliance be placed upon the interlock switches for removing voltages from the equipment.

RESUSCITATION

AN APPROVED POSTER ILLUSTRATING THE RULES FOR RESUSCITATION BY THE PRONE PRESSURE METHOD SHALL BE PROMINENTLY DISPLAYED IN EACH RADIO, RADAR, OR SONAR ENCLOSURE. POSTERS MAY BE OBTAINED UPON REQUEST TO THE BUREAU OF MEDICINE AND SURGERY.

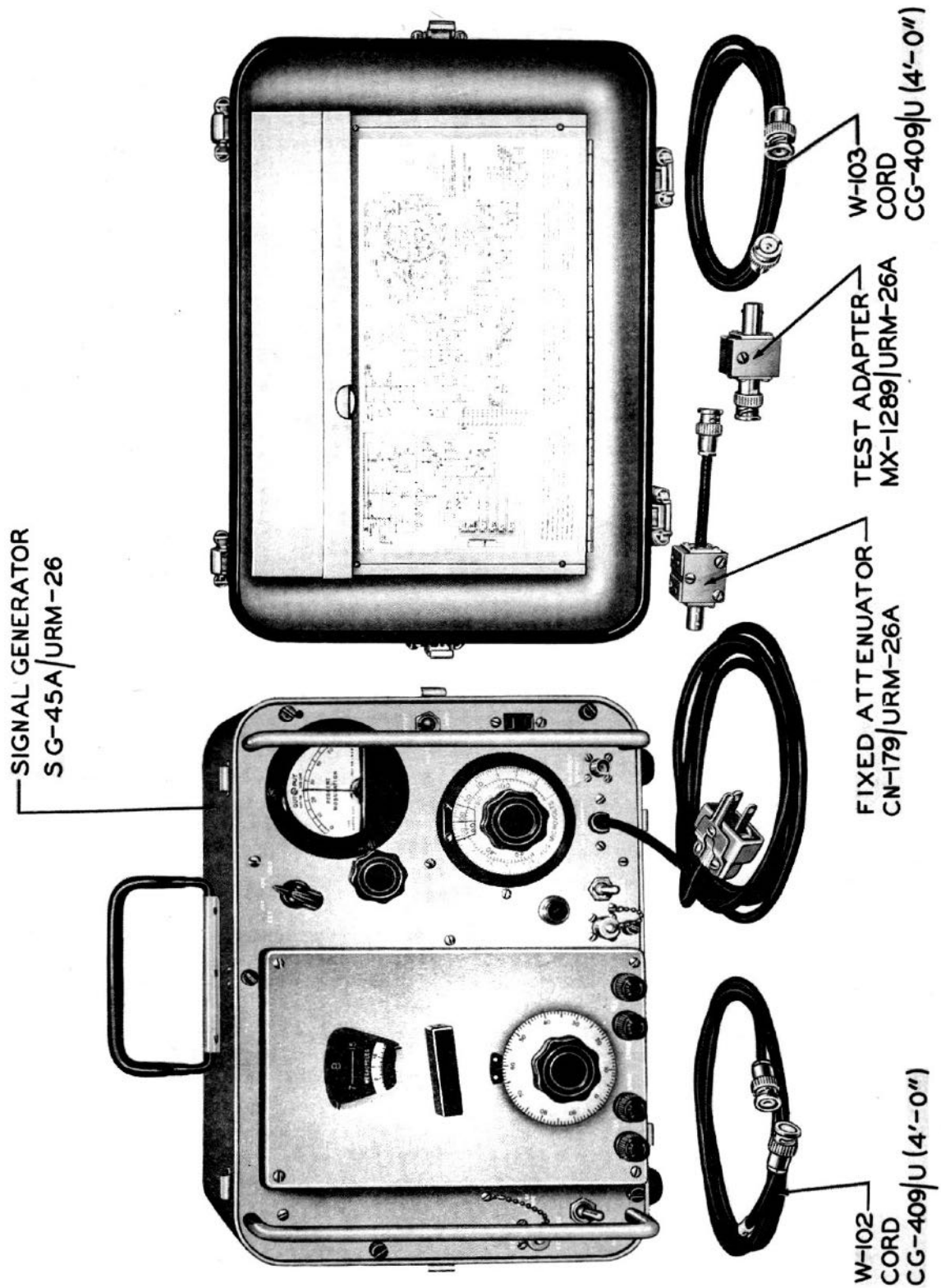


Figure 1-1. RF Signal Generator Set AN/URM-26A

SECTION 1
GENERAL DESCRIPTION

1. INSTRUCTION BOOK COVERAGE.

a. Instruction Book NAVSHIPS 92482 covers only the operation of RF Signal Generator Set AN/URM-26A and associate equipment as listed in Table 1-1.

2. PURPOSE AND BASIC PRINCIPLES.

a. RF Signal Generator Set AN/URM-26A is portable test equipment for the generation of radio frequency signals over the frequency range 3 to 405

sists of RF Signal Generator SG-45A/URM-26, and accessories as itemized in Table 1-1.

4. REFERENCE DATA.

a. Nomenclature: RF Signal Generator Set AN/URM-26A.

b. Contract Number NObsr-52212, dated 10 January 1951.

c. Contractor: Measurements Corporation, Boonton, New Jersey.

d. Cognizant Naval Inspector: Inspector of Naval Material, Newark, New Jersey.

TABLE 1-1. EQUIPMENT SUPPLIED

| QUANTITY PER EQUIPMENT | NAME OF UNIT | NAVY TYPE DESIGNATION | OVERALL DIMENSIONS | | | VOLUME | WEIGHT |
|------------------------|-------------------------|-----------------------|--------------------|--------|-------|--------|--------|
| | | | HEIGHT | WIDTH | DEPTH | | |
| 1 | RF Signal Generator Set | AN/URM-26A | 11½ | 15⅝ | 10¾ | 1.1 | 36.5 |
| 1 | RF Signal Generator | SG-45A/URM-26 | 11½ | 15⅝ | 10¾ | 1.1 | 35.7 |
| 2 | Cord | CG-409/U (4'0") | 48 | | | | 0.3 |
| 1 | Fixed Attenuator | CN-179/URM-26A | 5 | 1-1/16 | ¾ | | 0.3 |
| 1 | Test Adapter | MX-1289/URM-26A | 2-7/16 | 1-1/16 | ¾ | | 0.2 |
| 2 | Instruction Books | NAVSHIPS 92482 | | | | | |
| 1 | Equip. Spares | See Note* | | | | | |

Unless otherwise stated, linear dimensions are in inches, volume in cubic feet, and weight in pounds.
*Note: Not always included.
Not always same when included.

megacycles. Amplitude of output voltage across the terminals of a terminated 50-ohm cable is continuously variable from 50,000 microvolts to .1 microvolt (-13 to -127 DBM).

b. It is used primarily for testing and determining the characteristics of radio frequency receivers, amplifiers, filters and similar equipment operating within the specified frequency range.

c. It operates from a power source of 115 volts, 50 to 1000 cycles.

3. MAJOR UNIT.

a. RF Signal Generator Set AN/URM-26A con-

e. Number of packages per complete equipment:
(1) when equipment spares are not furnished.
(2) when equipment spares are furnished.

f. Total cubical contents:

(1) Crated: 2.9 cubic feet, less equipment spares.

cubic feet, including equipment spares.

(2) Uncrated: 1.1 cubic feet, less equipment spares.

cubic feet, including equipment spares.

- g. Total weight:
 (1) Crated: 58 pounds, less equipment spares.
 pounds, including equipment spares.
 (2) Uncrated: 36.5 pounds, less equipment spares.
 pounds, including equipment spares.
- h. Frequency range: 3 to 405 megacycles.
- i. Tuning range of each band:
 (1) Band A 3 to 7 megacycles
 (2) Band B 7 to 15 megacycles
 (3) Band C 15 to 30 megacycles
 (4) Band D 30 to 78 megacycles
 (5) Band E 78 to 180 megacycles
 (6) Band F 180 to 405 megacycles
- j. Type of frequency control; inductance-capacitance.
- k. Types of emission:
 (1) Continuous wave (CW).
 (2) Amplitude modulated continuous wave (MCW).

- (3) Pulsed continuous wave (PCW) using external pulse generator.
- l. Output voltage: Nominal, .05 volt maximum across a 50-ohm load.
 Range, 0.1 microvolts to 50,000 microvolts.
- m. Output impedance: 50 ohms.
- n. Frequency accuracy: $\pm 0.5\%$.
- o. Frequency stability over a two-hour period at constant ambient temperature and after a warm-up period of 30 minutes:
 (1) $\pm 0.1\%$ 3 to 100 megacycles.
 (2) $\pm 0.15\%$ 100 to 405 megacycles.
- p. Modulation frequencies:
 (1) Internal: 400 and 1000 cycles per second.
 (2) External: 100 to 20,000 cycles per second.
- q. Modulation capability: continuously variable 0 to 50%.
- r. Characteristics of power supply: 115 volts $\pm 10\%$, single phase, 50 to 1000 cycles, 70 watts.

TABLE 1-2. SHIPPING DATA

| SHIPPING BOX NO. | CONTENTS | | OVERALL DIMENSIONS | | | VOLUME | WEIGHT |
|------------------|-------------------------|-------------|--------------------|---------|------------------|--------|--------|
| | NAME | DESIGNATION | HEIGHT | WIDTH | DEPTH | | |
| 1 | RF Signal Generator Set | AN/URM-26A | 16 $\frac{3}{8}$ | 18-1/16 | 15 $\frac{3}{4}$ | 2.9 | 58 |
| 2* | Equipment Spares | | | | | | |

Unless otherwise specified, linear dimensions are in inches, volume in cubic feet, weight in pounds.

*Note: Not always included.

Not always same when included.

TABLE 1-3. ELECTRON TUBE COMPLEMENT

| NUMBER INSTALLED | TUBE TYPE | REFERENCE SYMBOL | FUNCTION |
|------------------|-----------|----------------------|--|
| 3 | 6005 | V102 V105 V107 | Voltage Regulator Modulator Audio Osc. |
| 2 | 6AU6WA | V103 V106 | Voltage Regulator Audio Osc. |
| 1 | 6F4 | V110 | RF Osc. |
| 1 | 6X4WA | V101 | B+ Rectifier |
| 2 | 5814 | V104 V108 | VTVM & Mod. Amplifier Meter Rectifier |
| 1 | 5751 | V109 | Meter Amplifier |

TABLE 1-4. LAMP COMPLEMENT

| NUMBER INSTALLED | MANUFACTURERS DESIGNATION | REFERENCE SYMBOL | FUNCTION |
|---------------------|------------------------------|---------------------|-------------------|
| 1 | #44F | E101 | Pilot Light |
| 1 | #3WS6 | E102 | AF Osc. Control |
| 1 | #991 | E103 | Voltage Reference |

TABLE 1-5. CROSS REFERENCE—TUBES

| RELIABLE TYPE | EQUIVALENT STANDARD TYPE |
|---------------|--------------------------|
| 6005 | 6AQ5 |
| 6AU6WA | 6AU6 |
| 6X4WA | 6X4 |
| 5814 | 12AU7 |
| 5751 | 12AX7 |

SECTION 2
THEORY OF OPERATION

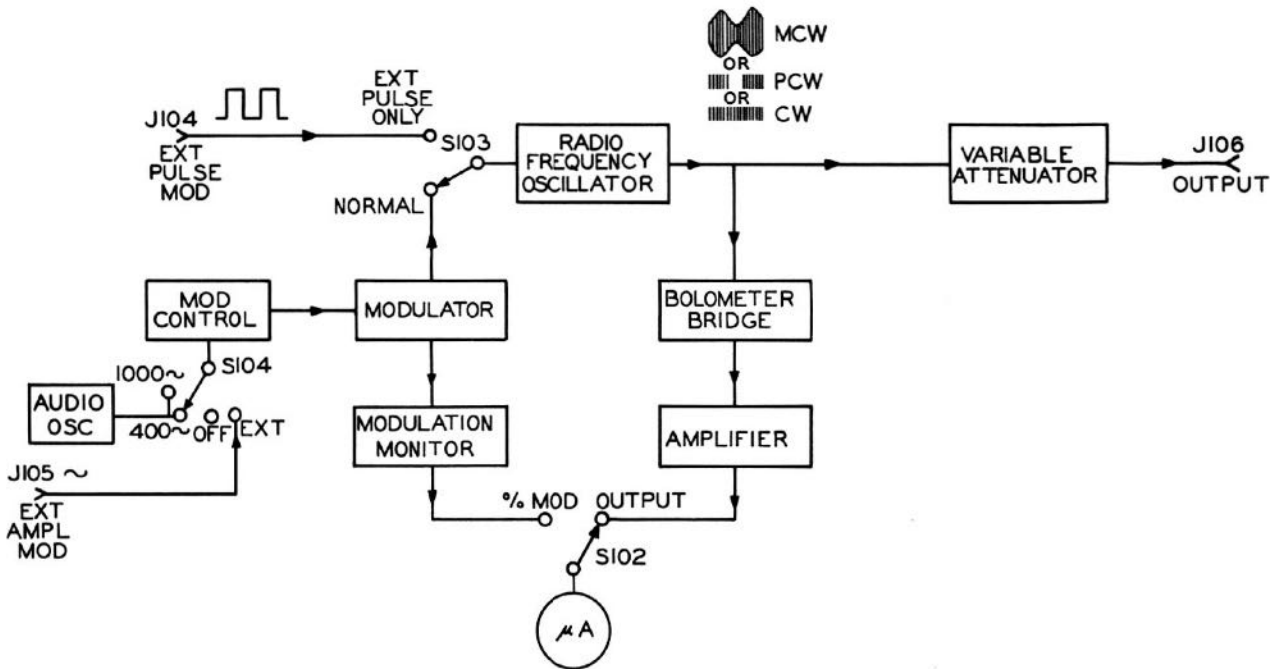


Figure 2-1. RF Signal Generator SG-45A/URM-26, Functional Block Diagram

1. GENERAL DESCRIPTION OF CIRCUITS.

a. A functional block diagram of RF Signal Generator SG-45A/URM-26 is shown in figure 2-1.

b. The RF oscillator is tunable from 3 to 405 megacycles in six ranges. This signal voltage is applied simultaneously to the output attenuator and output monitor circuits. The monitor circuit establishes the reference voltage level and indicates same when the meter switch is in the OUTPUT position.

c. The AF oscillator generates frequencies of 400 and 1000 cycles per second which are amplified by the modulator and applied to the plate circuit of the RF oscillator to modulate the carrier frequency. A portion of the modulator output is applied to the modulation monitor and meter when METER switch is in % MOD position.

d. The carrier may be modulated from an external audio frequency source by applying a signal to the connector marked EXT AMPL MOD. The modulation frequencies should be within the range 100 to 20,000 cycles per second.

e. The RF oscillator may be pulse-modulated from an external pulse generator capable of delivering a positive pulse of at least 40 volts across approximately 500 ohms. Normal output amplitude requires a positive pulse of 150 volts. The pulse repetition frequency should be within the range of 50 to 5000 pulses per second.

f. The power supply circuit operating from a 115-volt, 50- to 1000-cycle source provides the required ac and rectified dc voltages for all circuits.

2. POWER SUPPLY.

a. The power supply employs a conventional electronic tube rectifier V-101 to produce the direct current plate potential (B voltage) for all tubes. An electronic voltage regulator consisting of tubes V-102, V-103, and lamp E-103 maintains a substantially constant plate potential for the RF oscillator and modulator circuits, and also for the associated monitoring circuits. The power supply is assembled together with the modulator on a separate chassis as shown in figure 2-2. A functional schematic of the power supply is shown in figure 2-3.

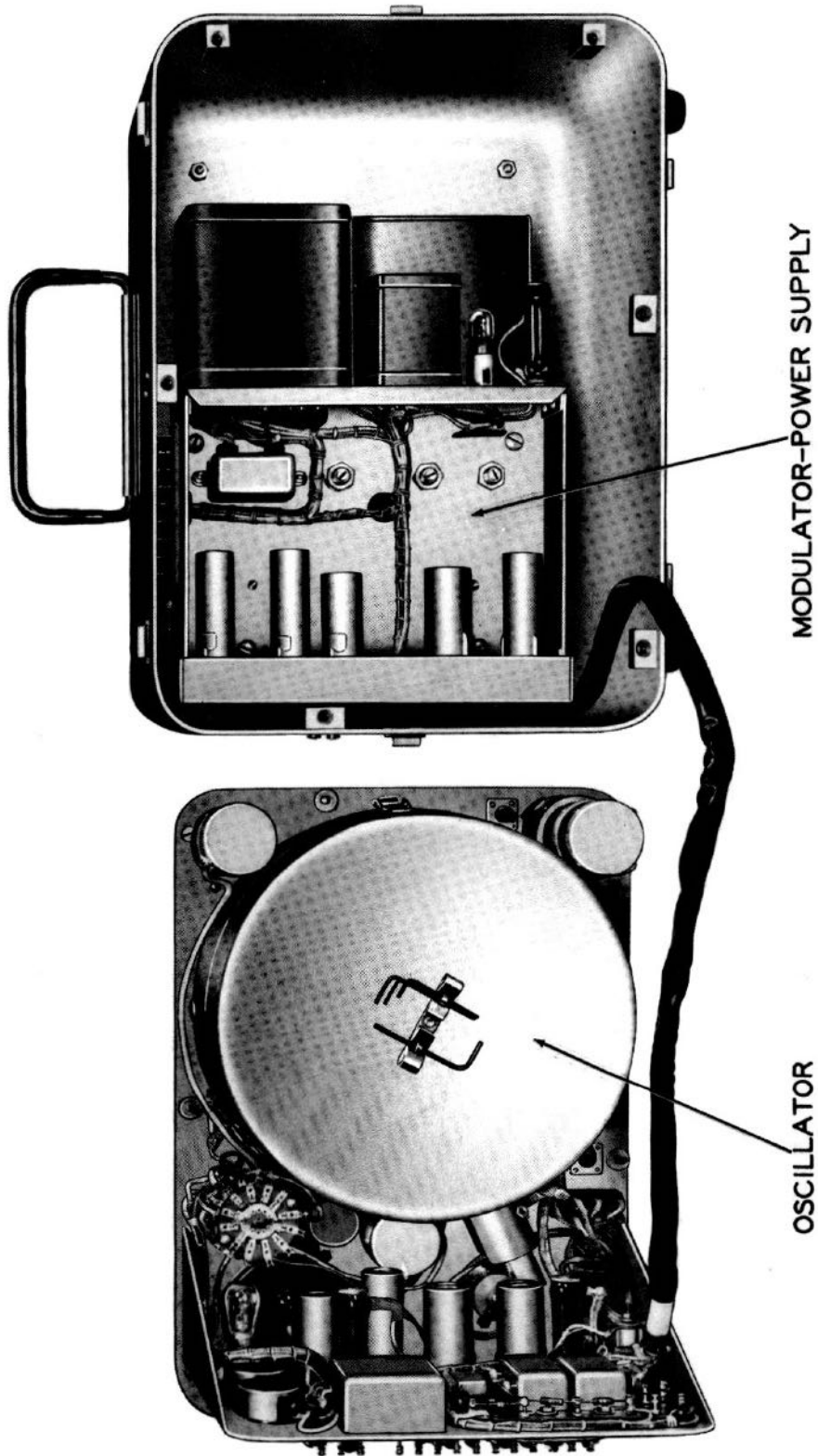


Figure 2-2. RF Signal Generator SG-45A/URM-26, Interior

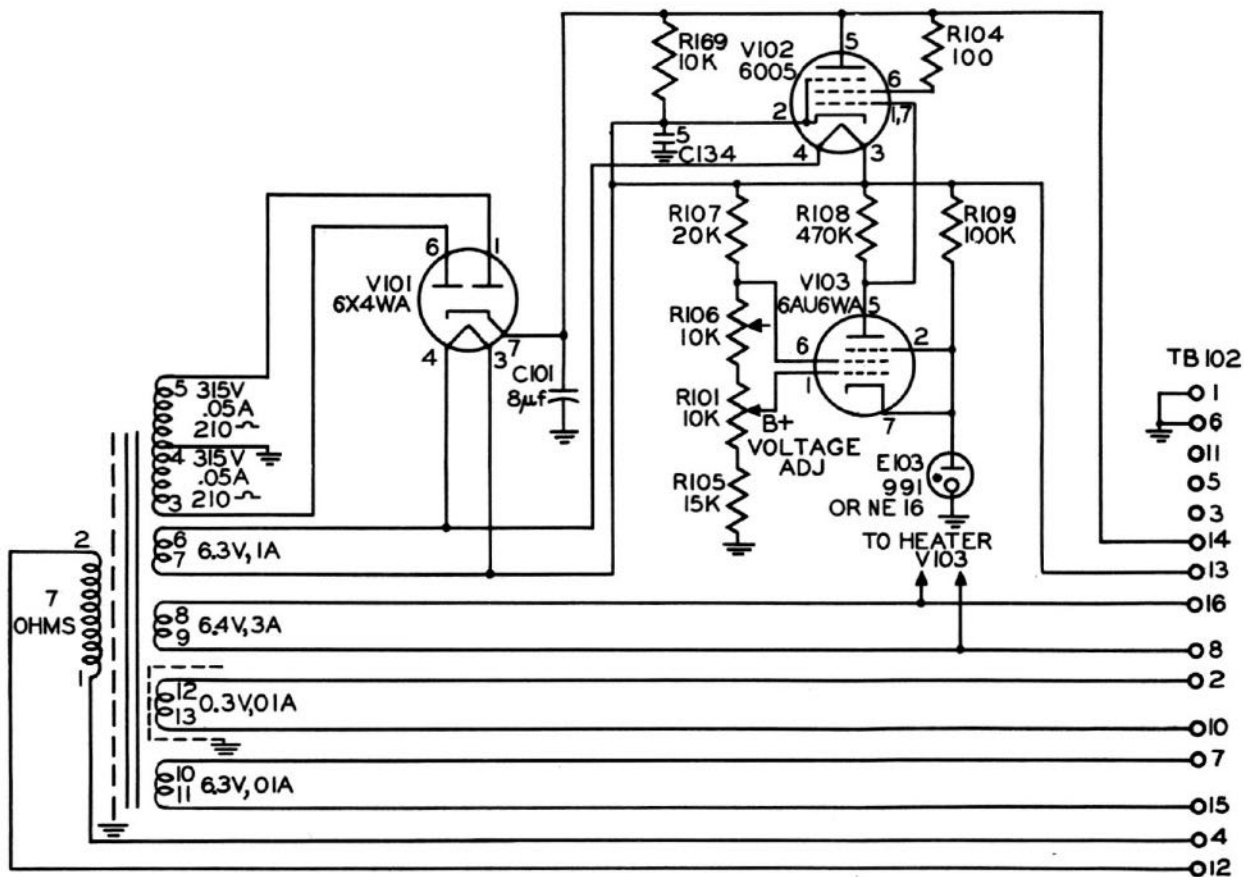


Figure 2-3. RF Signal Generator SG-45A/URM-26, Functional Schematic Diagram, Power Supply

b. Terminals 3 and 5 of the high voltage winding of transformer T-101 connect to plate terminals 6 and 1, respectively, of the rectifier tube V-101. Rectified dc voltage is developed between the cathode, pin 7, of tube V-101 and ground. Capacitor C-101 functions as a filter to reduce the residual ac component, leaving dc with superimposed ripple at the plate of tube V-102 and cable terminal 14. This voltage is unregulated and will vary with changes in line potential.

c. Tubes V-102 and V-103 and bias stabilizing glow lamp E-103 provide means for maintaining a high voltage supply which is essentially independent of line voltage. It also reduces the ripple voltage to a negligible value. The regulating and filtering action of this circuit is as follows:

(1) Plate current of tube V-102 flows through the other tubes and bias-stabilizing glow lamp E-103 to ground, developing a dc potential between cathode, pin 2, of tube V-102 and ground. The normal value of plate current, and therefore the potential between the cathode of tube V-102 and ground, is adjusted by the setting of potentiometer R-101 which controls grid bias of tube V-103.

(2) A change in the potential of tube V-102 cathode will correspondingly change the grid bias of tube V-103 and its plate current. This change of tube V-103 plate current, flowing through resistor R-108, changes the relative negative bias of the control grid of tube V-102 with respect to its cathode. The net effect of all these changes is to restore the potential at tube V-102 cathode to its original adjusted value.

(a) An increase of potential at tube V-102 cathode decreases grid bias of tube V-103 and increases its plate current. In turn this increase of current increases the negative bias of tube V-102 control grid which decreases plate current through tube V-102 and thus restores the potential at tube V-102 cathode to its adjusted value.

(b) A decrease of potential at tube V-102 cathode effects changes, in opposite sense to those described in paragraph immediately above, which also result in the restoration of potential at tube V-102 cathode to its adjusted value.

(3) Bias stabilizing glow lamp E-103 maintains a positive potential on the cathode of tube V-103 which is independent of variations in the potential

of tube V-102 cathode, pin 2. The grid potential of tube V-103 will always be positive with respect to ground but negative with respect to its cathode, pin 7.

(4) Two 6.3-volt secondary windings supply heater power for all tubes. One 6.3-volt winding supplies cathode potential for the RF output monitor circuit. One 0.3-volt winding supplies power to the bolometer bridge of the output monitor.

3. RADIO FREQUENCY OSCILLATOR.

a. The RF oscillator utilizes a conventional split Colpitts circuit and is shown schematically in figure 2-4. Six coils, each with switch-blade terminals and mounted on a rotatable disc, provide means for range selection. The range selector knob moves this disc simultaneously with the dial mask.

The dial mask indicates the range and reveals the corresponding scale on the frequency dial.

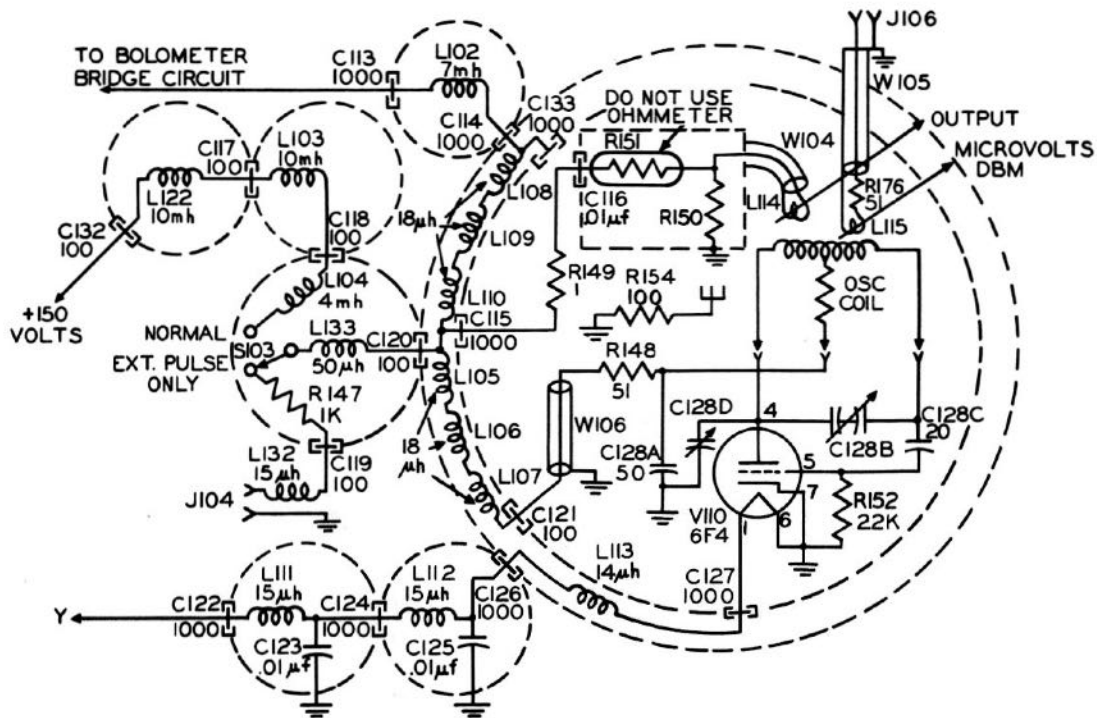


Figure 2-4. RF Signal Generator SG-45A/URM-26, Functional Schematic Diagram, RF Oscillator

b. Plate voltage for oscillator tube V-110 is applied through the center-tap of the coil in use. Excitation voltage for the grid circuit is applied through capacitor C-128C. Rectified grid current flows through resistor R-152 to provide self-bias for the oscillator tube.

c. The coil in use is positioned so that its magnetic field is concentrated opposite the tubes which form the mutual inductance attenuator. Coils L-114 and L-115 are coupling elements of the monitor and output circuits; their action is described in paragraph 4.

d. The oscillator unit is housed within two concentric, silver-plated, copper shields. Plate and heater supply leads are adequately filtered to prevent conduction of radio frequency currents beyond the oscillator compartment. This combination of shielding and filtering reduces RF leakage to a negligible value.

e. Resistor R-154 and Antenna E120 damp out resonance effects on the high frequency range.

4. OUTPUT SYSTEM.

a. The output system of RF Signal Generator SG-45A/URM-26 consists of a mutual inductance type variable attenuator and a bolometer bridge circuit which permits continuous monitoring of output voltage level. Driving voltages for the bolometer bridge and variable attenuator are obtained by magnetic coupling between the single turn coils, L-114 and L-115, and the oscillator coil which is positioned close to the open end of the attenuator tube and symmetrical with respect to the single turn loops.

b. The monitor coil L-114 is mounted flush with the open end of the movable attenuator tube which is controlled by the OUTPUT index dial. The output pickup coil L-115 is mounted on the attenuator plunger which is controlled by the MICROVOLTS dial. When set for maximum output, L-115 is flush and in exact alignment with L-114.

c. The variable attenuator tube functions as a waveguide below cut-off frequency and the intensity of the magnetic field within the tube will, therefore,

decrease in logarithmic proportion to the distance from the open end. The voltage induced in each pick-up coil (L-114 and L-115) is proportional to the intensity of the magnetic field at the plane of each coil.

The OUTPUT index (see figure 4-1) moves both L-114 and L-115 simultaneously and equally. The positioning of L-114 determines the voltage applied to the bolometer bridge which, in turn, establishes the reference output voltage level. The MICRO-VOLTS dial moves L-115 only and, when L-114 is properly positioned, indicates the voltage across a terminated 50-ohm cable.

d. RF OUTPUT MONITOR CIRCUIT: The output voltage reference level is established by adjusting the OUTPUT index (see figure 4-1) to bring the output meter pointer to the red line. This setting indicates that the high frequency bolometer bridge is in balance. A functional schematic diagram of the bolometer bridge which serves as monitor of RF output is shown in figure 2-5.

For the purpose of simplification, RF filter circuits have been omitted from figure 2-5. The action of the meter tube V-108 is explained in paragraph 2-4c. It is sufficient at this time to state that, with no voltage on the grids of V-108, the meter M-101 reads at center scale; the presence of an ac voltage on these grids will cause the meter to deflect from center scale, the direction being determined by the relative phase of this voltage with respect to the voltage appearing between the cathodes and ground.

(1) Referring to figure 2-5, resistors R-126, R-128, R-129, and bolometers R-151 and R-155 form a Wheatstone bridge circuit which is driven by the ac potential across A₁-A₂. When the voltage drop across R-128 equals that across R-149 and R-151 and the voltage drop across R-129 equals that across R-126 and R-155, no potential difference will exist between point B and ground; this is known as a balanced bridge and is the condition that establishes the output voltage reference level.

(2) Bolometers R-151 and R-155 each consist of a fine platinum wire, sealed in an evacuated glass tube. Current from the RF source and from the 0.3-volt winding of transformer T-101, flowing through these bolometers, will heat their elements thereby causing changes in resistance. In the bridge circuit of figure 2-5, current at power line frequency will flow through both bolometers but current from the RF oscillator flows only through bolometer R-151, being by-passed to ground by capacitor C-116. At RF, resistor R-150 is in shunt with R-151 and serves to terminate cable W-104 in 50 ohms. At power frequencies, R-150 is effectively short-circuited by coil L-114 and, therefore, forms no part of the bridge.

(3) When bridge is balanced, meter M-101 reads at center scale. Displacing the position of L-114 will increase or decrease the resistance of R-151 thereby unbalancing the bridge and causing meter M-101 to read right or left of center scale.

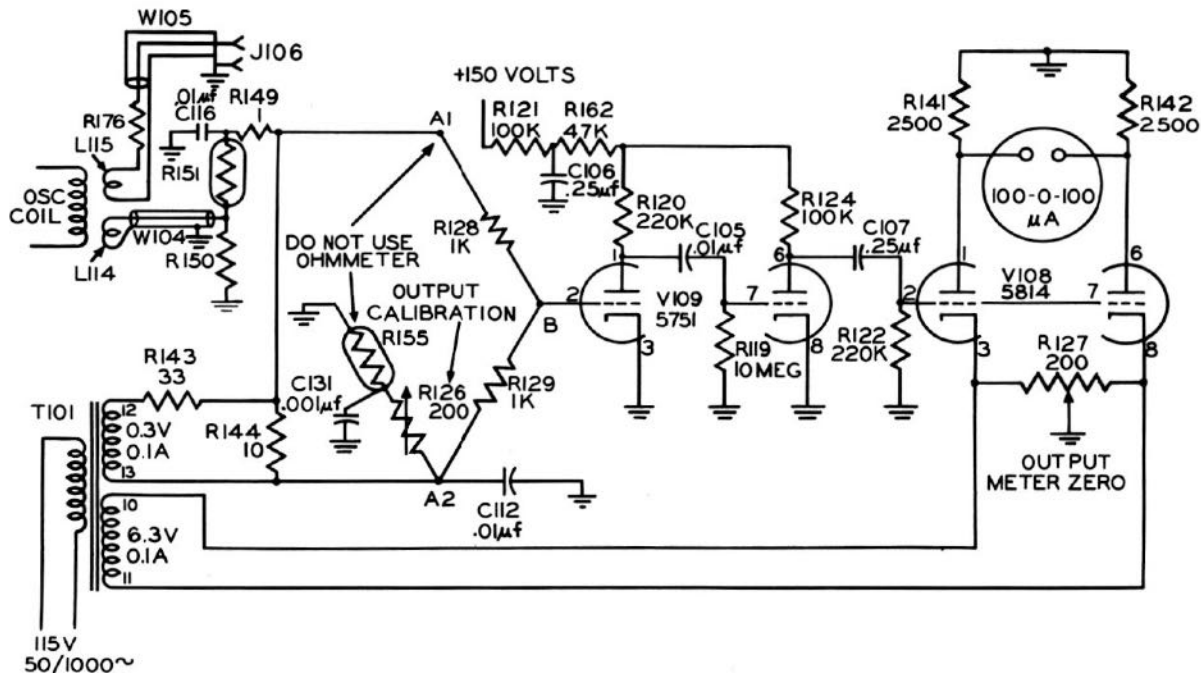


Figure 2-5. RF Signal Generator SG-45A/URM-26, Functional Schematic Diagram, RF Monitor

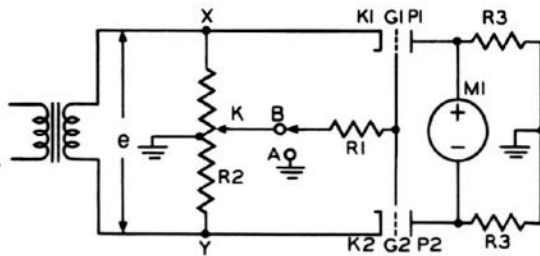


Figure 2-6. Simplified Schematic Diagram, Meter Balancing Circuit

e. The action of the meter circuit is illustrated by figure 2-6. Let grid resistor R-1 be grounded at point A and supply an ac potential, *e*, across cathodes K-1 and K-2. As both plates are normally at ground potential, conduction will occur only when cathode potentials are negative with respect to ground. With the circuit arrangement illustrated, opposite halves of the tube will conduct on alternate half-cycles of applied voltage.

(1) During the first half-cycle of applied voltage the plate of the conducting triode will be negative with respect to the non-conducting triode and current will flow through meter M-1. On the second half-cycle the polarity of the plates will be reversed and the direction of current flow through meter M-1 will be reversed. By adjusting the ground contact on potentiometer R-2 the potential drop across meter M-1 can be made equal and opposite for each half cycle of applied voltage *e*. The average current flow, being the algebraic sum of the currents during each half cycle, will then be zero and the meter M-1 will read zero.

(2) Let resistor R-1 be connected to slide contact K and balance will be maintained only when K is at ground potential. Moving K towards Y will decrease the potential difference between grid G-2 and cathode K-2 while increasing the potential difference between grid G-1 and cathode K-1. This is equivalent to saying that, relative to ground, the potential applied to grid G-2 is in phase with the potential applied to cathode K-2 while the voltage

applied to grid G-1 is out of phase with the voltage applied to K-1. The effect of this phasing is to cause the current from plate P-1 to cathode K-1 during the conduction period to exceed that from plate P-2 to cathode K-2 during the conduction cycle of the second triode. As a result, the "average" current flow through meter M-1 will exceed zero and the pointer will deflect in one direction.

(3) If contact K is moved towards X, the average current flow through meter M-1 will be in the reverse direction and the pointer will deflect in the opposite direction.

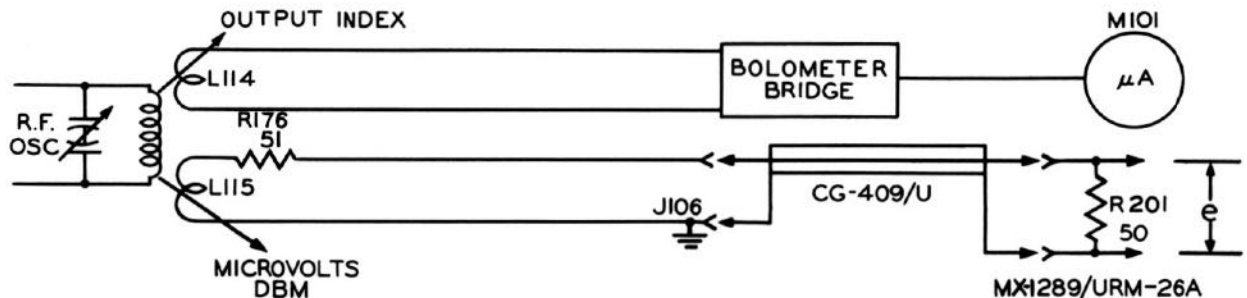
f. Referring back to figure 2-5, the relative phase of the voltage applied to the grids of tube V-108 with respect to the voltage on the cathodes is determined by the resistance of bolometer R-151. When the resistance of R-151 is greater than the value required for balance, (this occurs when L-114 is coupled too tightly to the RF oscillator) the phase of the voltage applied to the grids of tube V-108 will cause meter M-101 to deflect to the right. When coil L-114 is too loosely coupled to the oscillator, the value of R-151 will be less than that required for balance and the phase of the grid voltage at tube V-108 will cause the meter to deflect to the left.

(1) The two-stage amplifier represented by V-109 serves merely to increase the sensitivity of the meter circuit by increasing the magnitude of the voltage developed between point B and ground as a result of bridge unbalance.

g. RF ATTENUATOR: Coupling loop L-115 moves axially within the attenuator tube under control of the MICROVOLTS dial. The voltage developed in the coil is proportional to the strength of the magnetic field at any point within the tube. When the bolometer bridge is balanced, as described in paragraph 2-4c, the MICROVOLTS dial indicates the voltage across a terminated, 50-ohm cable (see figure 2-7). Resistor R-176 serves to improve the VSWR of the output system.

5. AUDIO OSCILLATOR.

a. A functional schematic diagram of the audio oscillator is shown in figure 2-8.



e = OPEN CIRCUIT VOLTAGE ACROSS R 201

Figure 2-7. RF Signal Generator SG-45A/URM-26, Functional Schematic Diagram, Output System

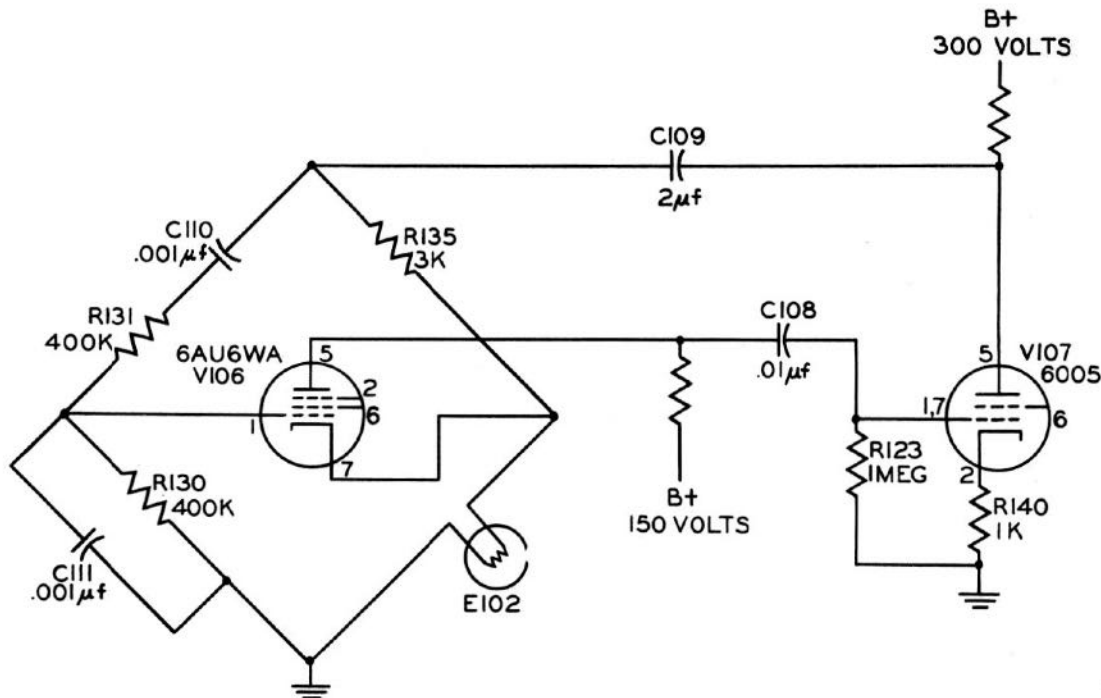


Figure 2-8. RF Signal Generator SG-45A/URM-26, Functional Schematic Diagram, AF Oscillator

b. The AF oscillator consists of tubes V-106 and V-107. These tubes function as a two-stage resistance coupled AF amplifier the output of which is applied to its input through a frequency-selective network which is actually a Wien bridge, as shown in figure 2-8. Oscillation will occur at the frequency at which phase shift through the bridge is zero.

c. Resistance-capacitance oscillators have been employed for many years and since the theory of operation is amply covered in textbooks and handbooks, it will be discussed but briefly here. Referring to figure 2-8 the output of tube V-107 is applied, through the resistance-capacitance network consisting of R-130, R-131, C-110 and C-111, to the grid of tube V-106 and through the resistive network consisting of R-135 and E-102 to the cathode of tube V-106. The first network provides regenerative feedback voltage in proper phase to sustain oscillations while the second network provides degenerative feedback voltage to minimize distortion and stabilize the amplitude of output voltage. The latter function is controlled by lamp E-102; an increase in output voltage causes an increase in the resistance of this lamp which, in turn, increases the amount of degenerative feedback thus maintaining a constant amplitude of oscillation. Distortion is minimized by operating the tubes as Class A amplifiers.

d. As the value of resistor R-130 is equal to R-131 and the value of capacitor C-110 equal to C-111 the frequency of oscillation in cycles per second, will be

$$f = \frac{10^6}{2\pi RC}$$

where R (equal to R-130) is expressed in ohms and C (equal to C-111) is expressed in microfarads.

6. MODULATOR AND MODULATION MONITOR.

a. MODULATOR: The modulator circuit is a two-stage amplifier consisting of one triode of tube V-104 and tube V-105. A functional schematic diagram is shown in figure 2-9. Audio signal from either the internal oscillator or an external source is applied to grid #7 of tube V-104. The amplified signal developed across reactor L-101 is superimposed on the dc plate potential of the oscillator tube V-110 thereby varying the carrier amplitude at an audio rate.

b. MODULATION MONITOR: The signal voltage developed across reactor L-101 is applied to grid terminal #2 of tube V-104. This grid is connected to its associated plate thereby causing this section of the tube to function as a diode

(1) On positive halves of the audio frequency cycle, capacitor C-102 charges through resistor R-113 and $\frac{1}{2}$ of V-104. On negative half cycles, capacitor

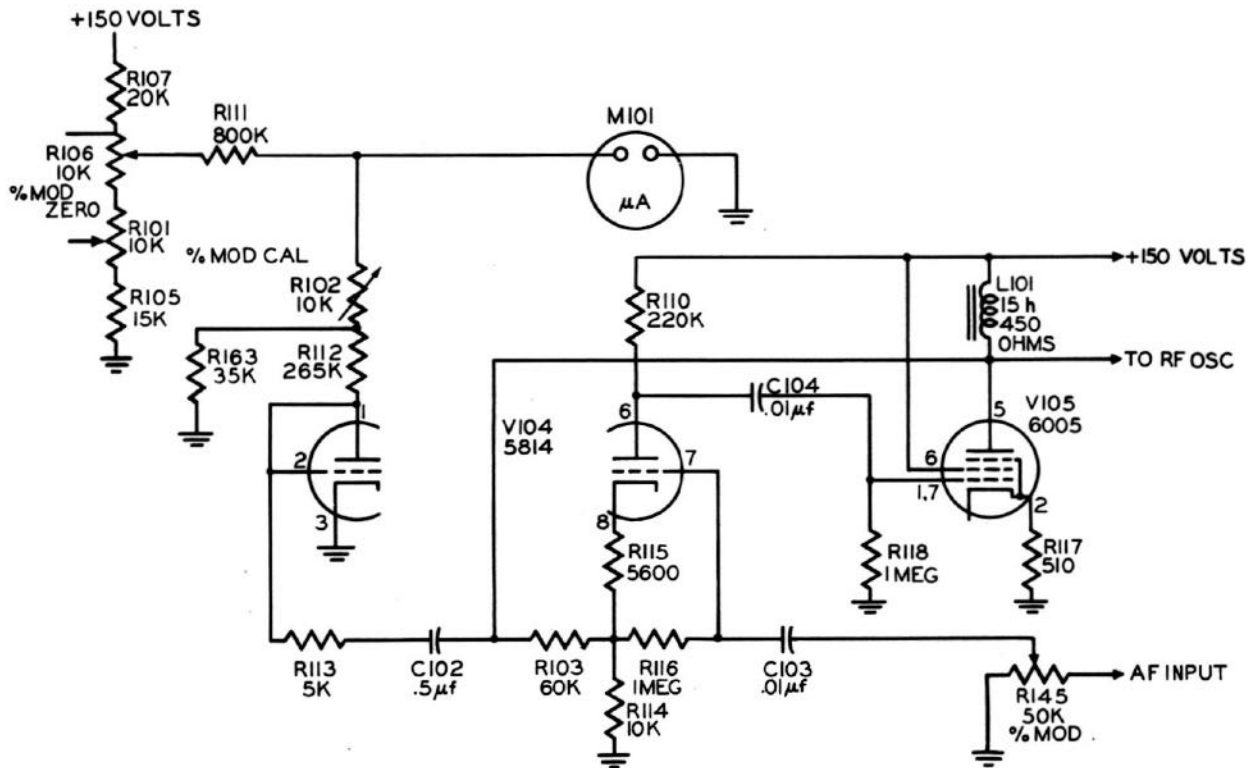


Figure 2-9. Signal Generator SG-45A/URM-26, Functional Schematic Diagram, Modulator and Modulation Monitor

C-102 discharges through R-113, R-112, R-102 and the meter, when the METER switch is in the % MOD position. R-163 is a shunt permitting wider adjustment of the full scale reading of the meter. The meter reading is thus proportional to the modulating voltage developed across reactor L-101.

(2) Meter M-101 is calibrated to read modulation percentage. Potentiometer R-102 provides means for setting the reference reading during the calibration procedure.

(3) Meter M-101 is a zero center scale meter. With switch S-102 in the % MOD position, current flowing through R-111 causes the meter pointer to assume a conventional left hand zero position with no modulation applied. The zero reading may be corrected by means of resistor R-106.

7. EXTERNAL MODULATION.

a. External modulation between 100 and 20,000 cycles may be applied through connector J-105.

b. When AMPLITUDE MODULATION switch S-104 is placed in EXT position the internal AF oscillator is made inoperative, by grounding the grid of tube V-106, and the % MOD control R-145 is connected across input connector J-105.

8. PULSE MODULATION.

a. Pulsed carrier output may be obtained by connecting a suitable pulse generator to connector J-104.

Switch S-103 must be placed in the EXT PULSE ONLY position to disconnect the internal plate supply for oscillator tube V-110. The pulse generator must be capable of delivering a positive pulse of 40 to 150 peak volts across 500 ohms. A 150-volt pulse will give approximately the same carrier amplitude as that obtained under CW conditions. For lower voltage pulses, the carrier amplitude is determined from the PULSE OUTPUT CORRECTION chart, figure 4-4.

b. The minimum value of pulse width is limited by the tuning capacitance. Increasing capacitance increases the inherent inertia of the oscillator circuit and, consequently, limits the ability of the oscillator to respond to short pulses. Pulse widths as short as six microseconds may be obtained at any frequency. Shorter pulses may be obtained at the higher frequencies in each range. The inertia of the oscillator circuit causes a delay in response of the oscillator to an applied pulse of approximately one to three microseconds. The width of the output pulse will be the same as that of the input pulse.

9. STANDBY HEATER.

a. Resistors R-160 and R-161 provide a source of heat to maintain the internal temperature slightly above the external ambient temperature during standby period. This provision tends to prevent condensation of moisture within the case.

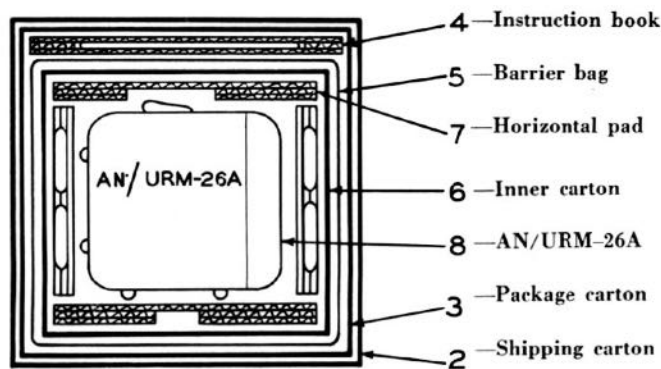
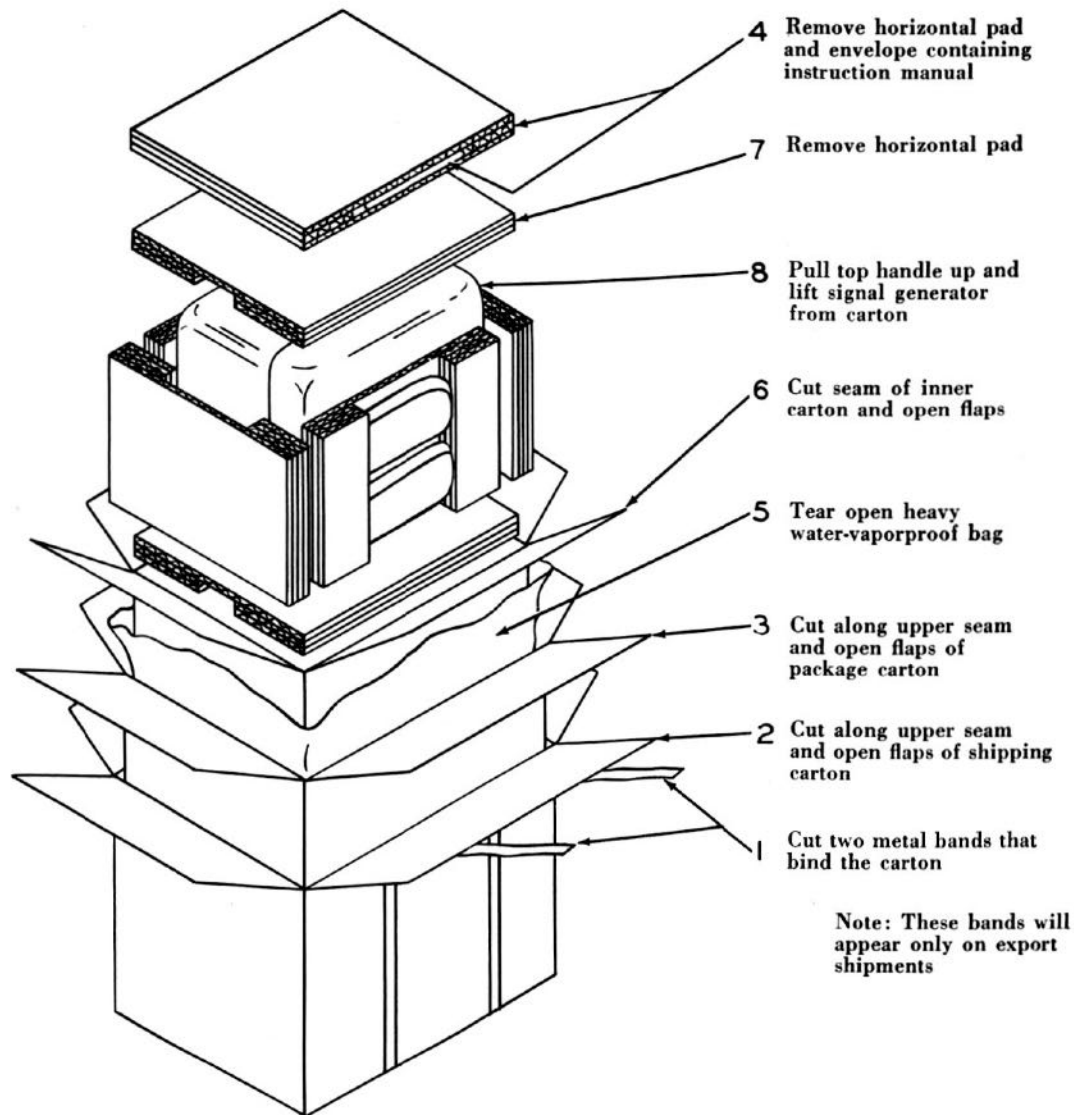


Figure 3-1. RF Signal Generator Set AN/URM-26A, Typical Packaging

SECTION 3

INSTALLATION

1. UNPACKING.

a. Packaging details and instructions for unpacking the instrument are given in Figure 3-1. The equipment is packaged in a specially cushioned carton which is then sealed in a water-moistureproof barrier and overpacked in its shipping carton. Packages intended for overseas shipment are further protected by metal strapping at each end of the carton.

b. Within the cover of the combination case are stored:

- (1) One instruction book.
- (2) Two Cords CG-409/U (4'-0").
- (3) One Fixed Attenuator CN-179/URM-26A.
- (4) One Test Adapter MX-1289/URM-26A.

c. Electron tubes are installed in their sockets.

d. Two spare fuses are installed on front panel.

2. INSTALLATION.

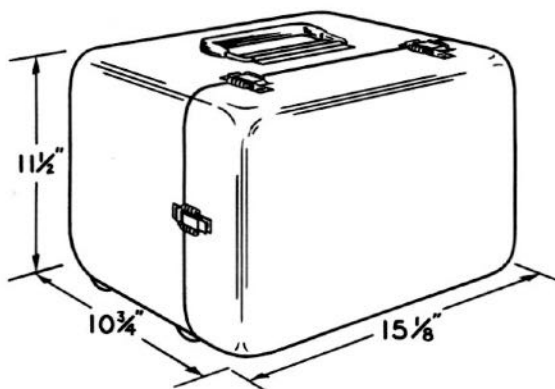


Figure 3-2. RF Signal Generator Set AN/URM-26A, Outline Dimensional Drawing

a. Outline dimensions of the signal generator are shown in Figure 3-2. This is portable test equipment and does not require permanent installation.

b. The equipment may be operated with the panel in either the vertical or horizontal position. It should be positioned close enough to the equipment under

test to permit use of the test cables supplied. All control operations and connections are made at the front panel. If possible place the generator above and behind the unit being worked on; this provides space for tools and for movement of the equipment under test.

c. The following preliminary settings and checks are required prior to placing the signal generator in operation (see figure 4-1, Section 4).

- (1) Place ON-POWER switch S-101 at POWER.
- (2) Make required output connections to equipment under test (see Section 4).
- (3) Rotate MICROVOLTS-DBM dial I-103 to maximum counter-clockwise position.
- (4) Place NORMAL-EXT PULSE ONLY switch S-103 at NORMAL.
- (5) Place AMPLITUDE MODULATION switch S-104 at OFF.
- (6) Rotate % MOD control E-108 fully counter-clockwise.
- (7) Connect power cable W-101 to 115 vac source.
- (8) Place ON-POWER switch at ON.
- (9) Allow equipment to warm up for at least 15 minutes.

3. INITIAL ADJUSTMENTS.

a. Operating adjustments are discussed in Section 4, OPERATION.

b. The preliminary checks described below will assist in determining if the equipment is operating properly:

- (1) Rotate range selector E-107 until any one range is detented in operating position.
- (2) Place METER switch S-102 at OUTPUT then adjust OUTPUT index H-108 to bring pointer of meter M-101 to red line.
- (3) Place METER switch S-102 at % MOD; meter pointer should swing left to zero.
- (4) Place AMPLITUDE MODULATION switch S-104 at either 400 or 1000.
- (5) Rotate % MOD knob E-108 clockwise; meter pointer should move up scale.

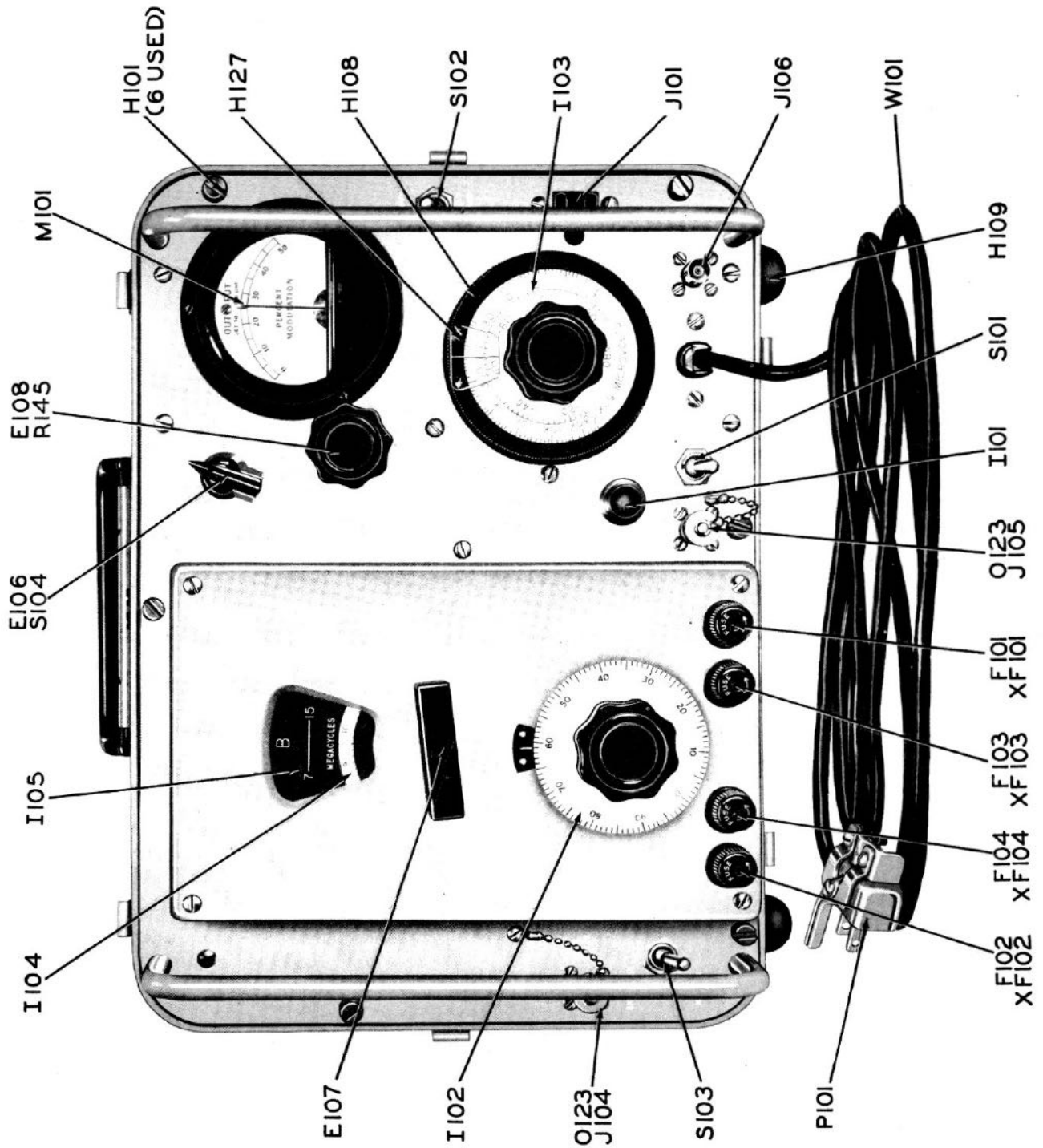


Figure 4-1. RF Signal Generator SG-45A/URM-26, Front Panel Diagram

SECTION 4 OPERATION

1. FUNCTIONS OF PANEL CONTROLS.

a. Panel controls of RF Signal Generator SG-45A/URM-26 are identified in figure 4-1.

b. MEGACYCLES:

(1) The range desired is selected by means of the bar knob beneath the window.

(2) Tuning is varied by the indicator dial directly below the bar knob. This dial has 100 uniform divisions. The dial drive disengages when the frequency dial stops are reached. By pushing the knob toward the bottom of the panel, the tuning drive may be disengaged at any time and the dial repositioned as desired.

c. OUTPUT: This control consists of the OUTPUT index (outer bakelite ring) and the DBM-MICROVOLTS dial.

(1) The OUTPUT index controls the input to one arm of the bolometer bridge and establishes the reference output voltage level.

(2) The DBM-MICROVOLTS dial controls carrier output voltage across a terminated 50-ohm cable connected to connector J-106, marked CG-409/U OUTPUT. The DBM scale indicates decibels below 1 milliwatt into 50 ohms.

d. AMPLITUDE MODULATION: This switch selects the desired internal modulation frequency or connects the modulator amplifier to the EXT AMPL MOD connector.

e. METER: This switch determines function indicated by meter M-101.

(1) When switch is in OUTPUT position, meter indicates output voltage reference level balance.

(2) When switch is in % MOD position, meter indicates modulation percentage.

f. % MOD: This knob adjusts the percentage of modulation.

g. EXT PULSE MOD: This switch provides means for connecting the RF oscillator to an external pulse generator.

(1) When placed in NORMAL position the plate circuit of the RF oscillator is connected to the internal power supply.

(2) When placed in EXT PULSE ONLY position the plate circuit of the RF oscillator is transferred to the pulse connector marked CG-409/U EXT PULSE MOD.

h. ON-POWER: This switch controls application of power to the instrument.

(1) When in ON position, switch connects power to primary of power transformer. Indicator light is energized.

(2) When in POWER position, switch connects power to standby heaters. Indicator light is not energized.

i. PANEL CONNECTORS:

(1) EXT PULSE MOD: Provides connection to external pulse generator through Cord CG-409/U.

(2) EXT AMPL MOD: Provides connection to external source of sine-wave modulation.

(3) OUTPUT: Provides connection to Cord CG-409/U.

2. PRELIMINARY ADJUSTMENTS.

a. Connect power cable to 115 V, 50-1000~ power source.

b. Set POWER switch S-101 at ON position. Pilot lamp should light.

c. Set EXT PULSE MOD switch S-103 at NORMAL position.

d. Rotate bar knob to set MEGACYCLES indicator at desired range.

e. Rotate tuning dial until a definite frequency is indicated.

f. Set METER switch S-102 at % MOD position.

g. Set AMPLITUDE MODULATION switch S-104 at either 400 or 1000 position.

h. Rotate % MOD control. Meter should deflect correspondingly.

i. Set AMPLITUDE MODULATION switch to OFF.

j. Attach one end of Cord CG-409/U to OUTPUT connector and the other end to either Test Adapter MX-1289/URM-26A or Fixed Attenuator CN-179/URM-26A.

k. Set METER switch S-102 at OUTPUT position.

l. Rotate OUTPUT index to set meter pointer to red line.

3. CONNECTIONS TO EQUIPMENT UNDER TEST.

a. Connections suitable for different characteristics of equipment under test are shown in figure 4-2.

b. The cording shown in figure 4-2a is suitable for general purpose use provided the input impedance of the equipment under test is 50-ohms resistive. This connection provides maximum voltage to the equipment being tested, the input voltage being indicated directly by the MICROVOLTS dial.

c. The cording shown in figure 4-2b is recommended when maximum accuracy is described. The use of Attenuator CN-179/URM-26A improves the voltage standing wave ratio (VSWR) but reduces the voltage available across the input terminals of the equipment under test.

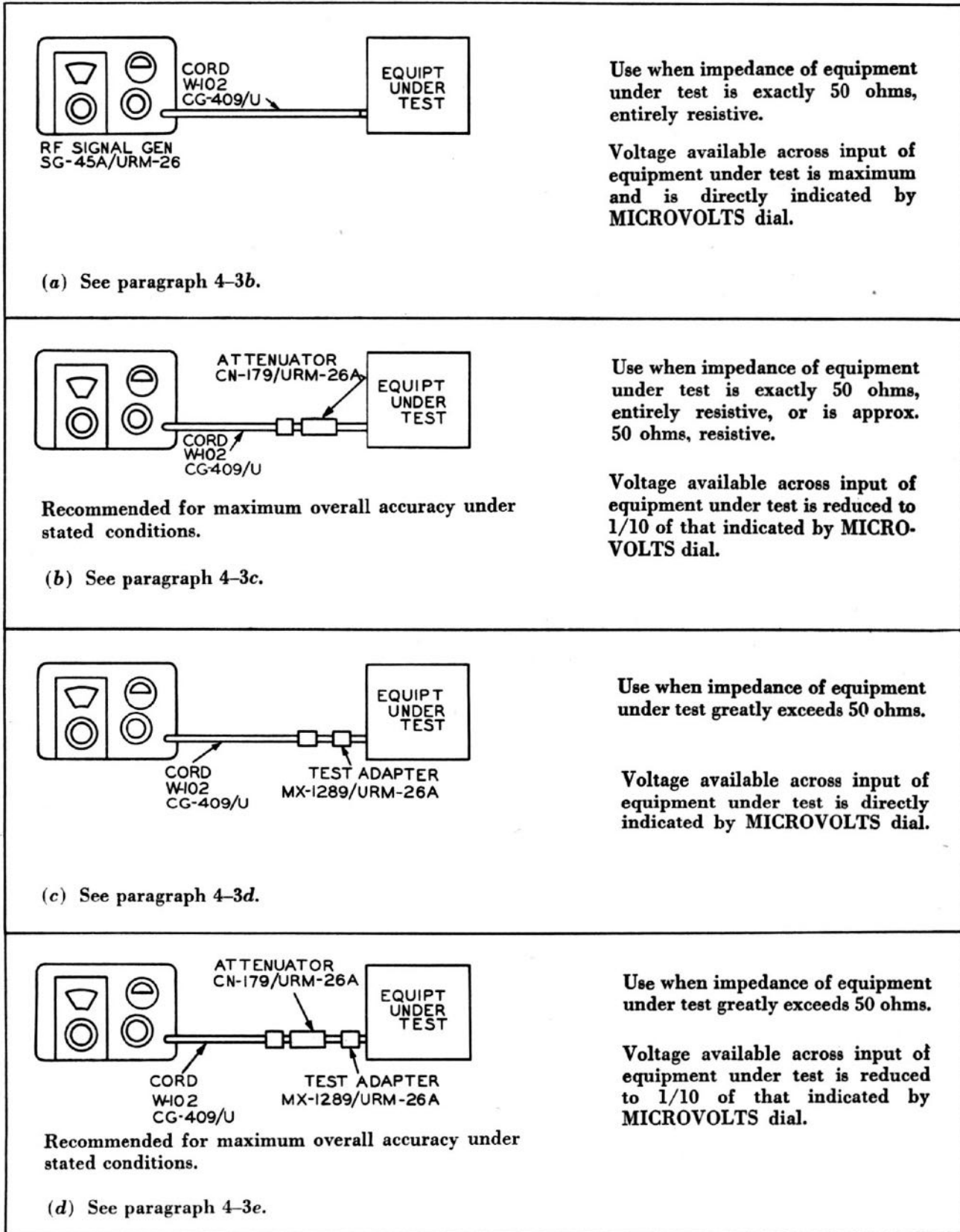


Figure 4-2. RF Signal Generator Set AN/URM-26A, Cording Diagram

(1) When the input impedance of the equipment under test is exactly 50 ohms resistive the voltage available across the input terminals will be one-tenth that indicated by the MICROVOLTS dial.

(2) When the input impedance of the equipment under test differs slightly from 50 ohms, the voltage across the input terminals will be a function of the input impedance and will not be exactly one-tenth of the MICROVOLTS dial reading. In general, if the load impedance is higher than 50 ohms, the input voltage will be proportionately higher than the dial indication while the reverse will be true when the input impedance is less than 50 ohms.

d. The cording shown in figure 4-2c is recommended when the input impedance of the equipment under test greatly exceeds 50 ohms. Using this cording, Test Adapter MX-1289/URM-26A provides the proper termination for Cord CG-409/U. Voltage across the input terminals of the equipment under test will be indicated directly by the MICROVOLTS dial.

e. The cording shown in figure 4-2d is recommended when the input impedance of the equipment under test greatly exceeds 50 ohms and maximum accuracy is desired. As in figure 4-2b, the use of Attenuator CN-179/URM-26A improves the VSWR but reduces voltage across the input terminals to one-tenth that indicated by the MICROVOLTS dial.

4. CONNECTIONS TO AUXILIARY EQUIPMENT.

a. Figure 4-3 illustrates methods for connecting RF Signal Generator SG-45A/URM-26 to either an external pulse generator or sine wave oscillator. These auxiliary equipments are not necessary for proper functioning of the signal generator but they expand its test facilities and range of application.

b. PULSE MODULATION: Figure 4-3a shows the signal generator connected to an external pulse generator. The pulse generator must be capable of delivering a positive pulse of 40 to 150 peak volts into a 500-ohm load.

(1) For pulse modulation, set OUTPUT meter to red line as follows:

(a) Set EXT PULSE MOD switch to NORMAL.

(b) Set AMPLITUDE MODULATION switch to OFF.

(c) Rotate OUTPUT index to bring meter pointer to red line.

CAUTION

Output index should not be disturbed during pulse operation. If it is inadvertently moved, it should be reset by repeating (a), (b), (c).

(d) Set EXT PULSE MOD switch to EXT PULSE ONLY.

(2) Under pulse modulation 150 V peak, the signal generator output is read directly from the MICROVOLTS dial. For any other input pulse volt-

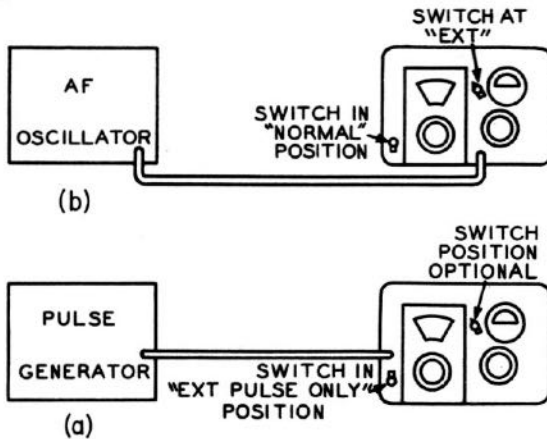


Figure 4-3. RF Signal Generator SG-45A/URM-26, Diagram for External Modulation

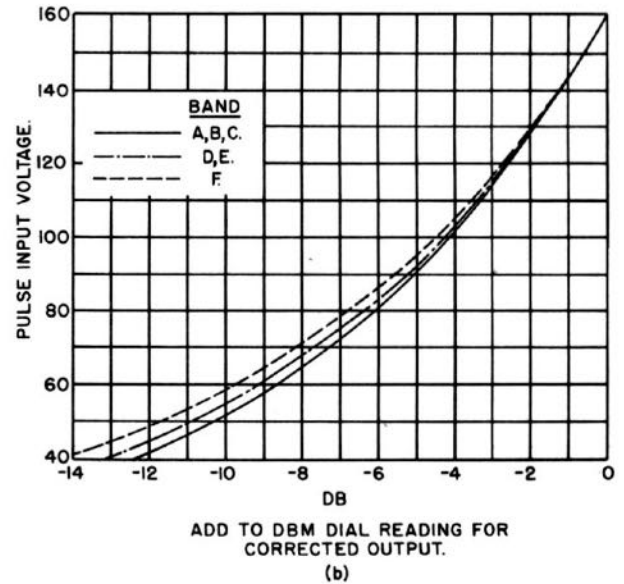
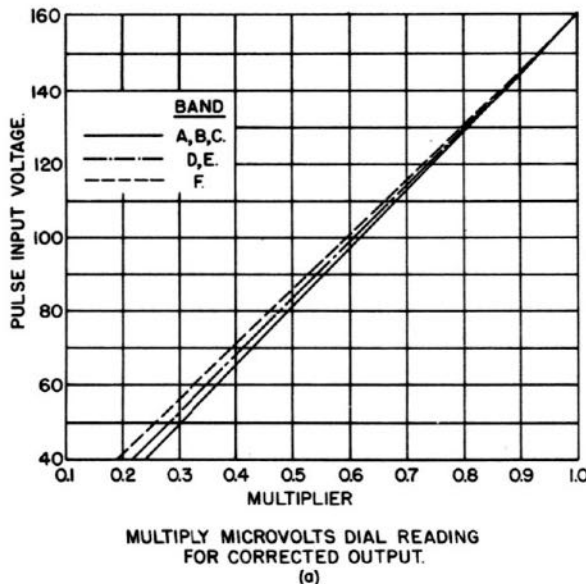


Figure 4-4. Pulse Output Correction

age, the MICROVOLTS dial indication must be multiplied by the factor shown on figure 4-4.

c. **SINE WAVE MODULATION:** Figure 4-3b shows the signal generator connected to an external sine wave generator. The sine wave generator must be capable of delivering 10 volts across 5000 ohms. The frequency of the generator should be in the range of 100 to 20,000 cycles per second.

CAUTION

When RF signal generator SG-45A/URM-26 is to be modulated from an external sine wave generator, switch S-103 must be in NORMAL position and amplitude modulation switch S-104 in EXT position. See figure 4-3.

(1) Modulation percentage is controlled by the % MOD knob and is indicated by the meter when the METER switch is in % MOD position.

5. MEASUREMENT OF RECEIVER SENSITIVITY.

a. Detailed instructions for measuring receiver sensitivity will usually be given in the instruction manual for the receiver under test. These instructions will include information on input and output impedances, the degree of modulation and the modulating frequency, the audio power output required for a given carrier input voltage, type of dummy antenna to be used between generator and receiver, the signal-to-noise ratios for true sensitivity, and the proper position or setting of the receiver controls. The procedure described herein is limited, therefore, to the functional operation of controls on RF Signal Generator SG-45A/URM-26.

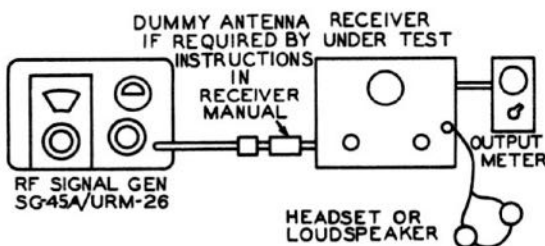


Figure 4-5. Typical Set-Up for Receiver Measurement

b. A typical set-up for measuring receiver sensitivity is shown in figure 4-5.

(1) Set receiver controls in accordance with instructions in receiver manual.

(2) Set the frequency dial of the receiver to the desired test frequency.

(3) Select equivalent frequency range on signal generator.

(4) Place METER switch in OUTPUT position, then turn OUTPUT index to bring meter pointer to red line. Set MICROVOLTS dial to 50K.

(5) Refer to receiver manual for recommended modulation frequency, degree of modulation, and

signal-to-noise ratio. Place AMPLITUDE MODULATION switch at either 400 or 1000 and METER switch in % MOD position. Adjust % MOD control to obtain required modulation percentage.

(6) Tune the signal generator to approximate resonance with receiver and reduce output voltage until signal is barely audible in headphones or readable on test meter. Tune generator to slightly lower and higher frequencies to arrive at resonant point that produces maximum output signal.

(7) Adjust MICROVOLTS dial to produce required reading on receiver output meter. Refer to figure 4-2 for effects of cording on MICROVOLTS dial indication.

6. MEASUREMENT OF RECEIVER SELECTIVITY.

a. Complete instructions for measuring selectivity should be given in the instruction manual for the receiver under test. The following instructions, therefore, cover functional operation of the controls of RF Signal Generator SG-45A/URM-26.

(1) Connect signal generator to receiver as shown in figure 4-5.

(2) Set receiver controls in accordance with instructions in receiver manual.

(3) Set the frequency dial of the receiver to the desired test frequency.

(4) Select equivalent frequency range on signal generator.

(5) Tune signal generator to resonance with receiver. The output voltage of the generator is usually set at some convenient level such as 1, 5 or 10 microvolts and the corresponding receiver output noted as the "reference" level.

(6) Determine the selectivity or band width curve as follows:

(a) Increase the voltage output of the signal generator to any convenient value.

(b) Detune the signal generator to the higher frequency and to the lower frequency where the same receiver "reference" output level is produced.

(c) Repeat (a) and (b) for successively greater voltage output values of the signal generator (usually in steps of 10, 100, 1000 times the voltage in (5)).

CAUTION

To avoid false indications due to overloaded receiver circuits, the detuning should extend sufficiently to produce a minimum receiver output. The desired reference level should then be restored by retuning the signal generator toward resonance.

7. DETERMINING SIGNAL-TO-NOISE RATIO.

a. The signal-to-noise ratio is closely associated with the measurement of true sensitivity. It is usually specified in the receiver manual for a given sensitivity and frequency.

b. To measure signal-to-noise ratio of a receiver, make connections as shown in figure 4-5 and follow instructions in receiver manual.

c. Set signal generator to desired frequency and output level.

d. Set pulse switch to NORMAL.

e. Set modulation switch to 400 or 1000.

f. Set meter switch to % MOD.

g. Adjust modulation to desired value.

h. Tune receiver to signal generator.

i. Adjust receiver for desired output.

j. Turn AMPLITUDE MODULATION switch to OFF and note receiver output.

k. The ratio of receiver output, with modulation, to that without modulation is the signal-to-noise ratio.

8. DETERMINING IMAGE RATIOS.

a. The "image" signal of a superheterodyne receiver differs in frequency from the desired signal by twice the intermediate frequency. When the frequency of the local oscillator is below the signal frequency the image will occur at a frequency that is less than the desired frequency by twice the intermediate frequency. It will be above the signal when the local oscillator frequency is greater than signal frequency.

b. The image ratio is measured, using the set-up shown in figure 4-5, as follows:

(1) Set receiver to desired frequency.

(2) Tune signal generator to receiver.

(3) Adjust signal generator output to produce convenient receiver output.

(4) Note MICROVOLTS dial reading of signal generator and output of receiver.

(5) Change signal generator frequency to nominal "image" frequency of receiver. Increase signal generator output to produce a convenient receiver output signal, then retune signal generator slightly for maximum receiver output.

(6) Adjust signal generator output to produce same receiver output noted in (4) above and note generator MICROVOLTS dial reading.

(7) The "image ratio" is the ratio of input voltage at image frequency to input voltage at resonant frequency for the same receiver output.

(8) The ratio is usually expressed in decibels, the conversion formula being

$$\text{image ratio, in db} = 20 \log_{10} \frac{E_2}{E_1}$$

wherein

E_1 = microvolts input at resonant frequency for selected receiver output.

E_2 = microvolts input at image frequency for same selected receiver output.

(9) If the readings noted in (4) and (6) above are taken from the DBM scale, the image ratio in db is the difference between these readings.

SECTION 5 OPERATOR'S MAINTENANCE

1. EMERGENCY MAINTENANCE.

Notice to Operators

Operators shall not perform any of the following emergency maintenance procedures without proper authorization.

a. **FUSE FAILURE:** Fuse failure will be indicated by failure of the pilot lamp to glow when POWER switch is placed in ON position. A further indication is failure of the meter to move from center scale when METER switch is at % MOD and AMPLITUDE MODULATION switch is at OFF.

(1) Spare, 1/2-ampere, 250-volt fuses (F-103, F-104) are mounted on the front panel of RF Signal Generator SG-45A/URM-26 adjacent to line fuses F-101, F-102.

WARNING

NEVER REPLACE A FUSE WITH ONE OF HIGHER RATING UNLESS CONTINUED OPERATION OF THE EQUIPMENT IS MORE IMPORTANT THAN PROBABLE DAMAGE. IF A FUSE BURNS OUT IMMEDIATELY AFTER REPLACEMENT DO NOT REPLACE IT A SECOND TIME UNTIL THE CAUSE HAS BEEN CORRECTED.

b. **TUBE REPLACEMENT:** The locations of all tubes in RF Signal Generator SG-45A/URM-26 are shown in figure 5-1.

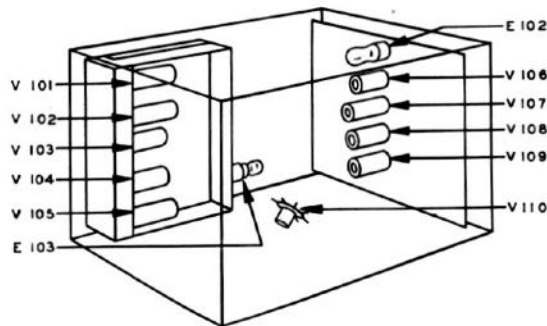


Figure 5-1. RF Signal Generator SG-45A/URM-26, Tube Locations

SECTION 6
PREVENTIVE MAINTENANCE

TABLE 6-1. ROUTINE MAINTENANCE CHECK CHART

| WHAT TO CHECK | HOW TO CHECK | PRECAUTIONS |
|--------------------------------|--|--|
| 1. RF Oscillator | <p>a. Set RANGE switch on each coil range, A through F.</p> <p>b. Meter balance should be obtainable on each calibrated coil range by rotating output index.</p> | Place METER switch at OUTPUT and pulse switch at NORMAL. |
| 2. AF Oscillator and Modulator | <p>a. Place AMPLITUDE MODULATION switch at 400 cycle position.</p> <p>b. Full-scale meter reading should be obtainable by rotating % MOD knob.</p> <p>c. Repeat a and b with switch at 1000.</p> | Place METER switch at % MOD and pulse switch in NORMAL position. |
| 3. Regulated Power Supply | <p>a. Place METER switch at % MOD.</p> <p>b. Meter should read zero on PERCENT MODULATION scale.</p> | Place AMPLITUDE MODULATION switch at OFF and pulse switch at NORMAL. |

1. ROUTINE MAINTENANCE.

a. When equipment is not in daily use the routine checks listed in Table 6-1 should be made at monthly intervals.

2. RETROPICALIZATION.

a. GENERAL: Equipment operated in highly humid climates is subject to excessive failure of parts and decreased operating efficiency caused by the accumulated effects of moisture and fungus rather than by inferior components. The effects of moisture on resistors, coils, capacitors and similar components can be recognized in the form of low insulation resistance, flashovers, and corrosion. Moisture also accelerates fungus growth which increases these effects.

b. REDUCING FAILURES: Failures resulting from the effects of moisture and fungus may be minimized by applying special fungicidal varnish per specification MIL-V-173A, to individual components, terminal boards, and chassis. This varnish contains a fungicide which retards fungus growth and provides a non-wetting surface.

(1) Equipments which have been treated are marked with the letters MFP. It is usually desirable

to re-treat the equipment after a period of use. Need for re-treatment may be indicated by excessive failures or by the visual effects noted in paragraph above. The frequency of re-treatment will be subject to prevailing climatic conditions.

c. When components are replaced, fungicidal varnish should be applied to soldered connections by means of a small brush.

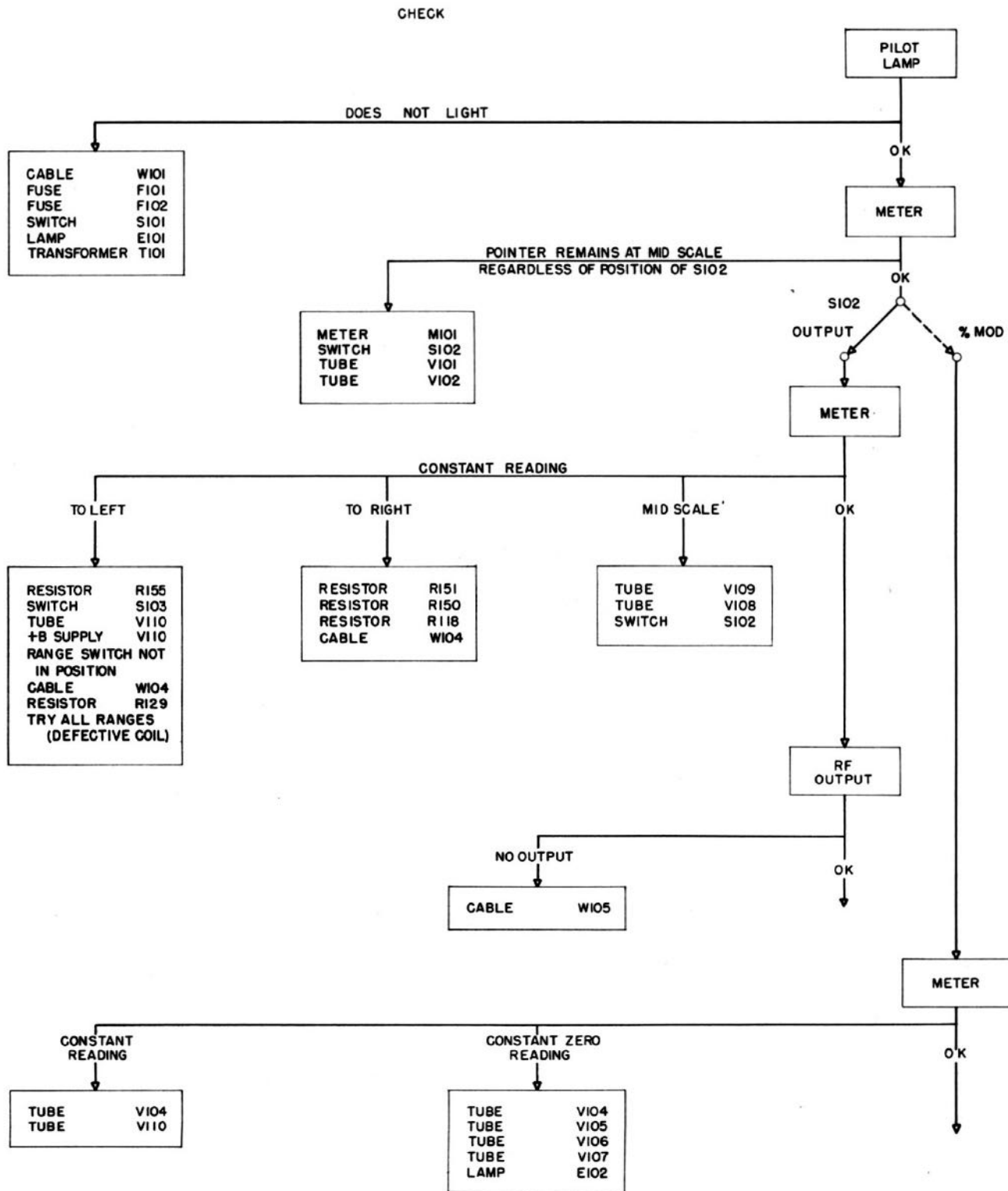
WARNING

VARNISH SHOULD NEVER BE APPLIED TO THE PLATES OF VARIABLE CAPACITORS, ELEMENTS OF POTENTIOMETERS, BEARINGS, GEARS AND OTHER MECHANICAL ASSEMBLIES.

3. LUBRICATION.

a. The mechanical assemblies within the signal generator are constructed to be free from excessive gear loading and high speed operating mechanisms. Hence, the manufacturer's lubrication will usually last the life of the instrument, and periodic lubrication is not required.

TABLE 7-1. TROUBLE SHOOTING CHART



SECTION 7

CORRECTIVE MAINTENANCE

TABLE 7-2. TEST EQUIPMENT FOR MAINTENANCE USE

| DESCRIPTION | TYPE |
|----------------------------|----------------------|
| Multimeter | AN/PSM-4 |
| Multimeter | ME-25A/U |
| Resistance Bridge | ZM-4/U |
| Frequency Meter | TS-186/UP |
| Frequency Meter | AN/USM-29 |
| Heterodyne Frequency Meter | TS-323/UR |
| Heterodyne Frequency Meter | Navy LR or LM series |
| Barretter Bridge | 202-B* |

*Measurements Corporation Model 202-B

1. TROUBLE SHOOTING AND REPAIR.

a. TROUBLE SHOOTING: The chart shown in Table 7-1 is arranged to enable the repairman to localize most of the common causes of failure in RF Signal Generator SG-45A/URM-26. All possible failures cannot be listed in a chart of this type, however, and occasionally the replacement of complete assemblies will be required to restore the instrument to first class condition. When repairs of this magnitude are indicated the instrument should be returned to a higher echelon with facilities for making the necessary repairs and test.

b. TEST EQUIPMENT: The technician will find a wide choice of test equipment suitable for servicing and maintaining RF Signal Generator Set AN/URM-26A. A list of instruments representative of those recommended for this purpose is given in Table 7-2.

c. TEST POINTS: Voltage and resistance data are shown in Figures 7-1 and 7-2. Locations of circuit components are shown in figures 7-3, 7-4, 7-5, and 7-6.

d. REPAIR: When component replacement is necessary care should be taken to make sure the new part is identical with the original component. This information can be obtained from the Maintenance Parts List, Section 8, of this manual. When replacing a part, always take care not to damage adjacent components or change their physical position.

e. REMOVING INSTRUMENT FROM CASE: Except for replacement of fuses, all replacements and readjustments are made from behind the panel. To remove the panel and its attached apparatus from the case proceed as follows (see figure 4-1):

- (1) Turn the case so that panel is horizontal.
- (2) Turn MICROVOLTS dial clockwise to stop.
- (3) Loosen six special black, round, slotted,

captive bolts.

- (4) Lift panel, carefully, straight up.

f. For all servicing, except the replacement of a few units in the power supply, it will be necessary to remove only the panel section from the case. To remove the power supply chassis, release the four black captive bolts whose heads are inside of the power supply chassis (see figure 7-6).

g. REPLACING POWER SUPPLY CHASSIS: To replace the power supply chassis proceed as follows:

- (1) Turn case so that open side is uppermost.
- (2) Place power supply chassis carefully in place inside case so that mounting bolts can engage in mounting posts.
- (3) Tighten four black captive bolts.

h. REPLACING INSTRUMENT CHASSIS: To replace panel section in case proceed as follows (see figure 4-1):

- (1) Turn case so that open side is uppermost.
- (2) Turn MICROVOLTS dial fully clockwise.
- (3) Lower panel, carefully, straight down into case so that internal cable wires fold between power supply chassis and case. Avoid scraping terminals or pinching wires.
- (4) Tighten six black captive bolts.

2. PLATE VOLTAGE ADJUSTMENT.

a. Plate voltage is adjusted by means of variable resistor R-101, B+ VOLT ADJ, (see figure 7-6). Prior to making any adjustments the instrument should be operated for a period of 15 minutes to permit circuits to become stabilized. Line voltage should be 115 volts $\pm 10\%$.

- (1) Connect a dc voltmeter, such as AN/PSM-4, between terminals 6 and 13 of terminal TB-102.
- (2) Use screwdriver to adjust variable resistor R-101 so that meter reads 160 volts ± 3 volts.

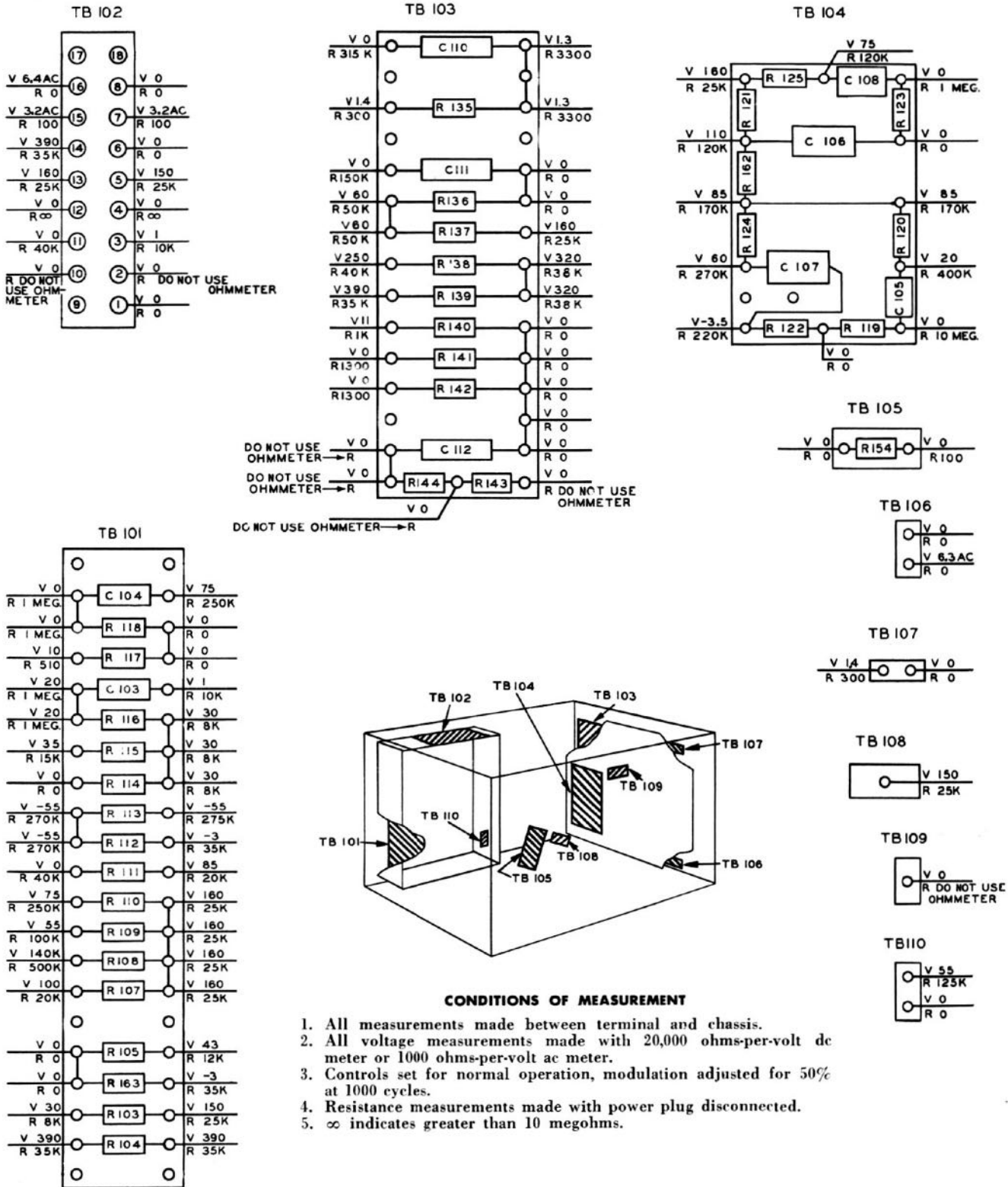


Figure 7-1. Voltage, Resistance and Parts Location of Terminal Boards

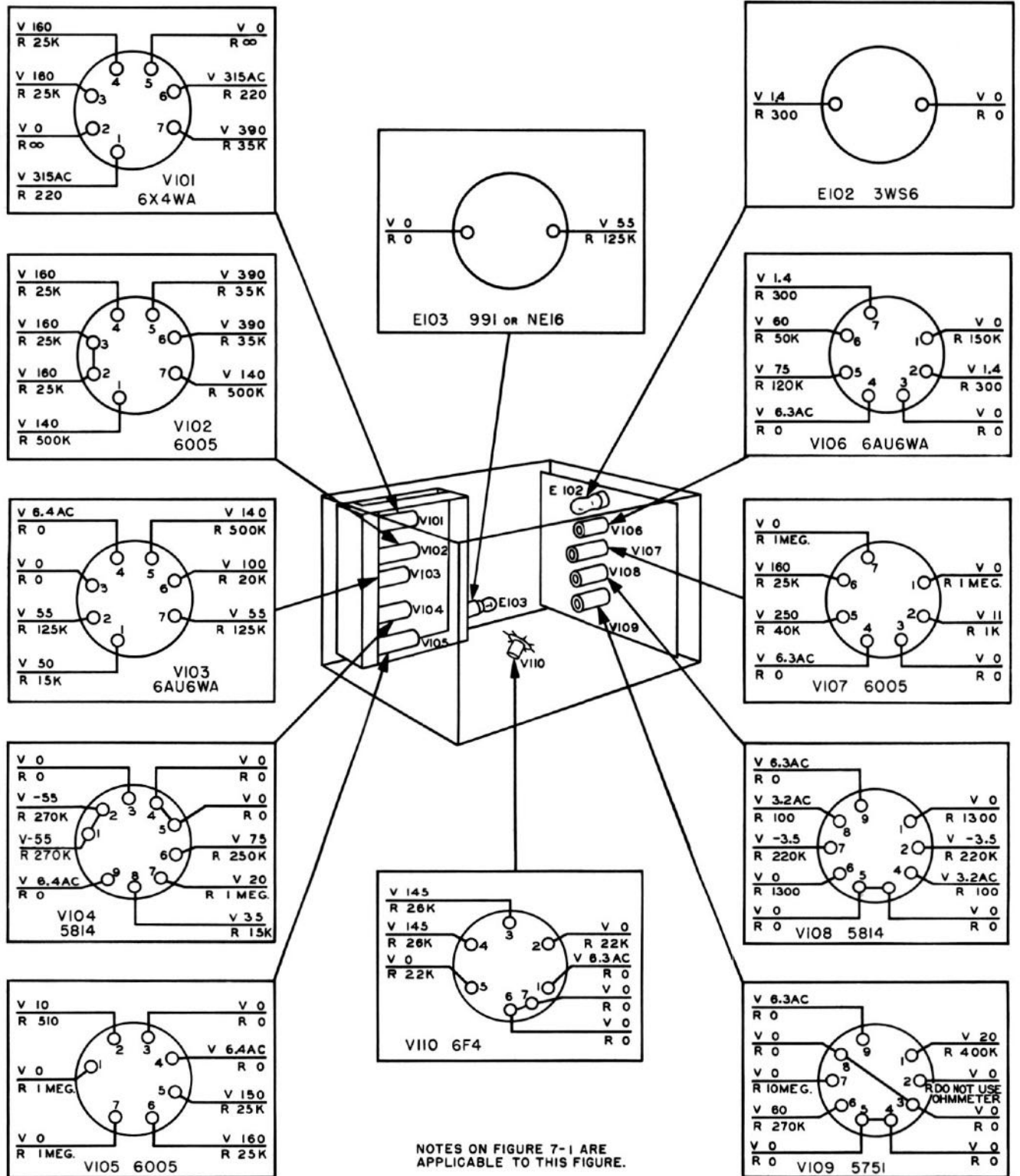


Figure 7-2. Tube Sockets Voltage and Resistance Data

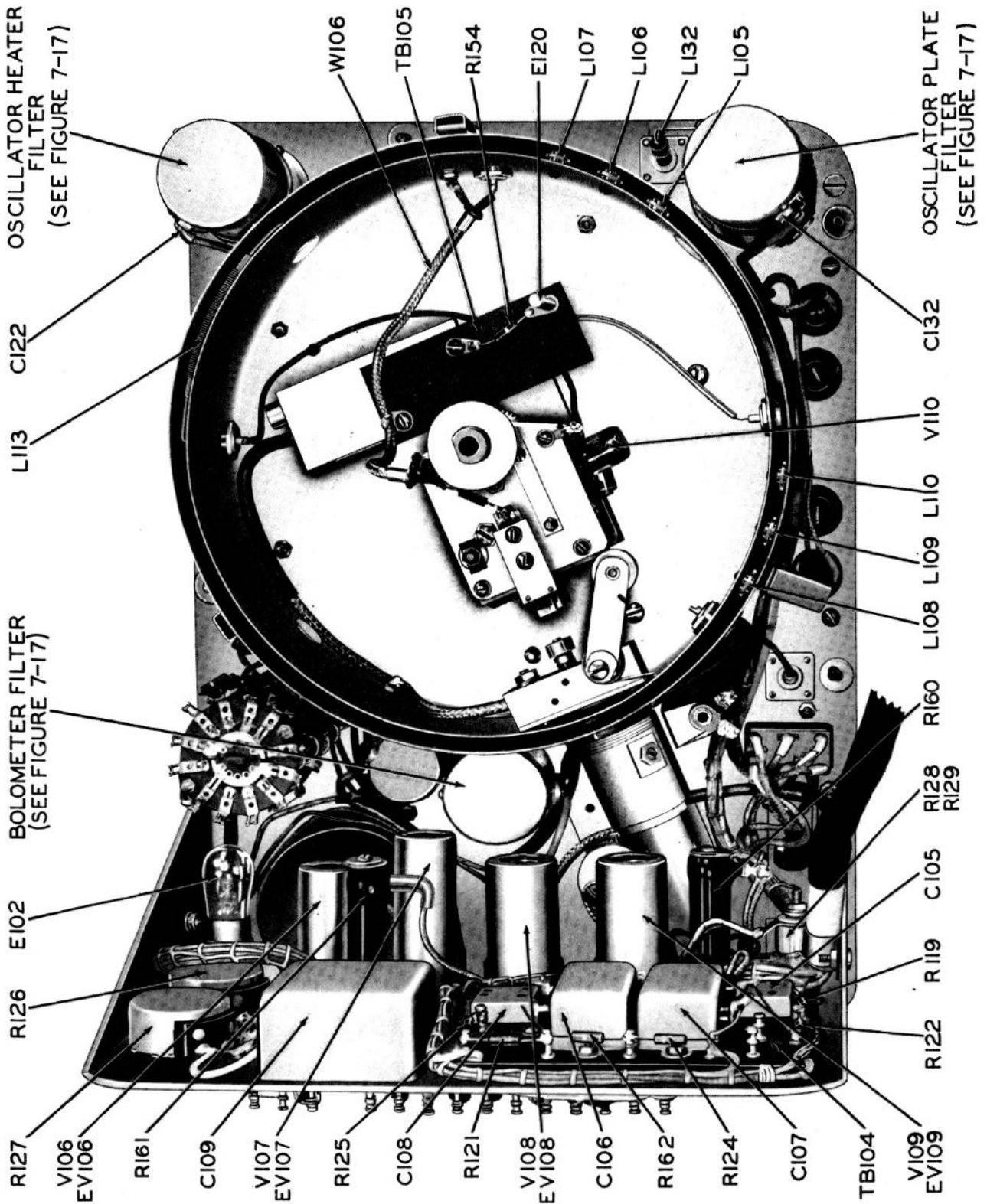


Figure 7-3. RF Signal Generator SG-45A/URM-26, Rear View

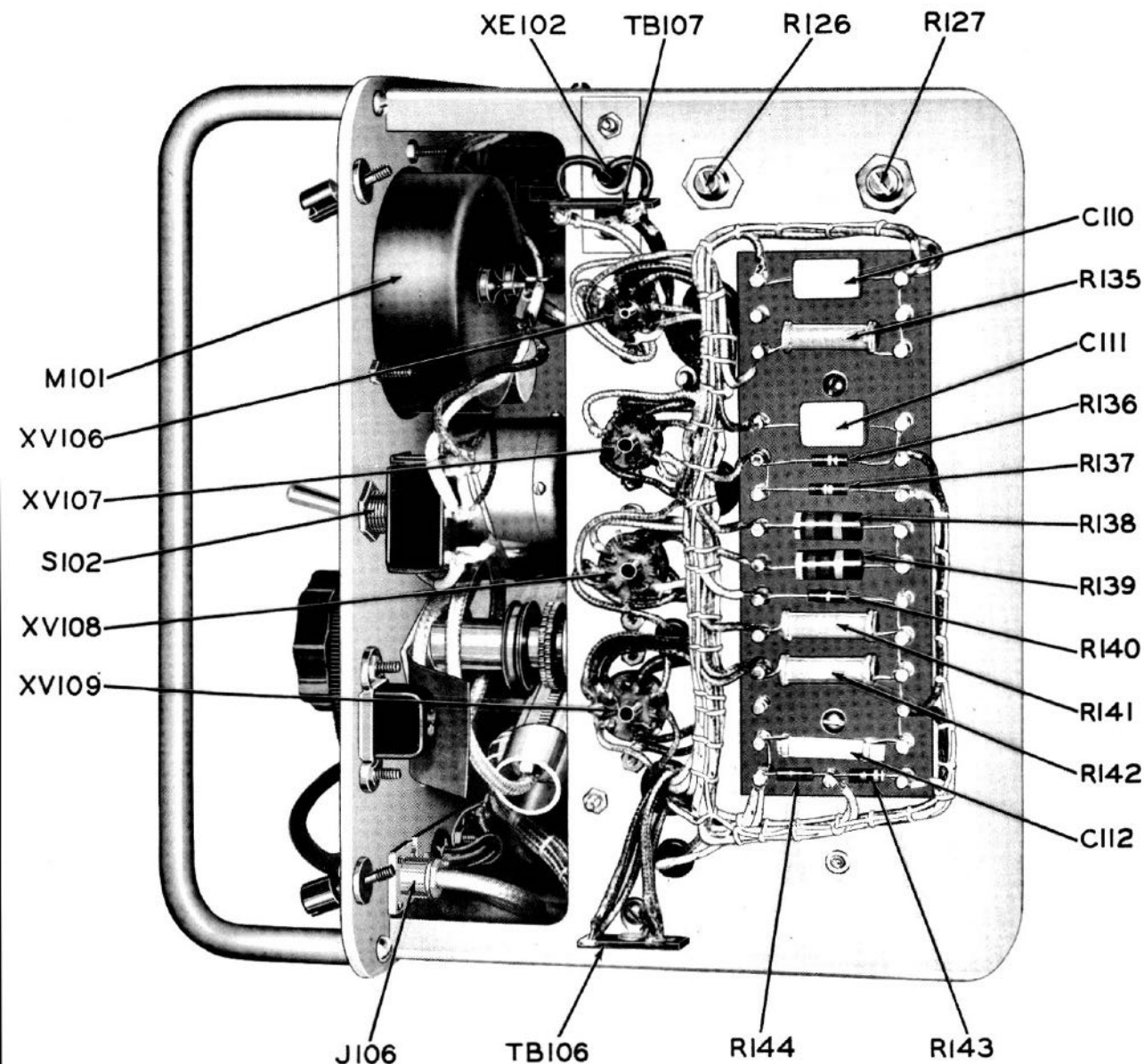


Figure 7-4. RF Signal Generator SG-45A/URM-26, Side View

3. OUTPUT METER ZERO ADJUSTMENT.

a. When V-108 is replaced, meter zero must be reset by means of OUTPUT METER ZERO resistor R-127, see figure 7-4.

- (1) Operate instrument for approximately 15 minutes to permit stabilization of tube characteristics.
- (2) Place METER switch in OUTPUT position.
- (3) Remove tube V-109 from its socket.
- (4) Adjust OUTPUT METER ZERO resistor R-127, with screwdriver, to bring meter pointer to red line.
- (5) Replace tube V-109.

4. OUTPUT METER CALIBRATION.

a. A Barretter Bridge, such as Measurements Corporation Model 202-B, is required for precision calibration of output voltage of signal generators operating in the range of 2 to 1000 megacycles.

b. The input impedance of the Model 202-B Barretter Bridge is 50 ohms. A UG-201/U Adapter will provide connection between the UG-88C/U connector on Cord CG-409/U and the input connector (UG-22/U) of the Model 202-B.

c. Prior to checking output voltage, remove signal generator from case and allow the instrument to operate at normal line voltage ($115 \pm 10\%$) for approximately 15 minutes to stabilize circuit components.

d. BARRETT BRIDGE METHOD: Connect signal generator to Measurements Corporation Model 202-B Barretter Bridge as shown in figure 7-7.

- (1) Set dial of Model 202-B at 50K.
- (2) Set MICROVOLTS dial of RF Signal Generator SG-45A/URM-26 at 50K, AMPLITUDE MODULATION switch at OFF and METER switch at OUTPUT.

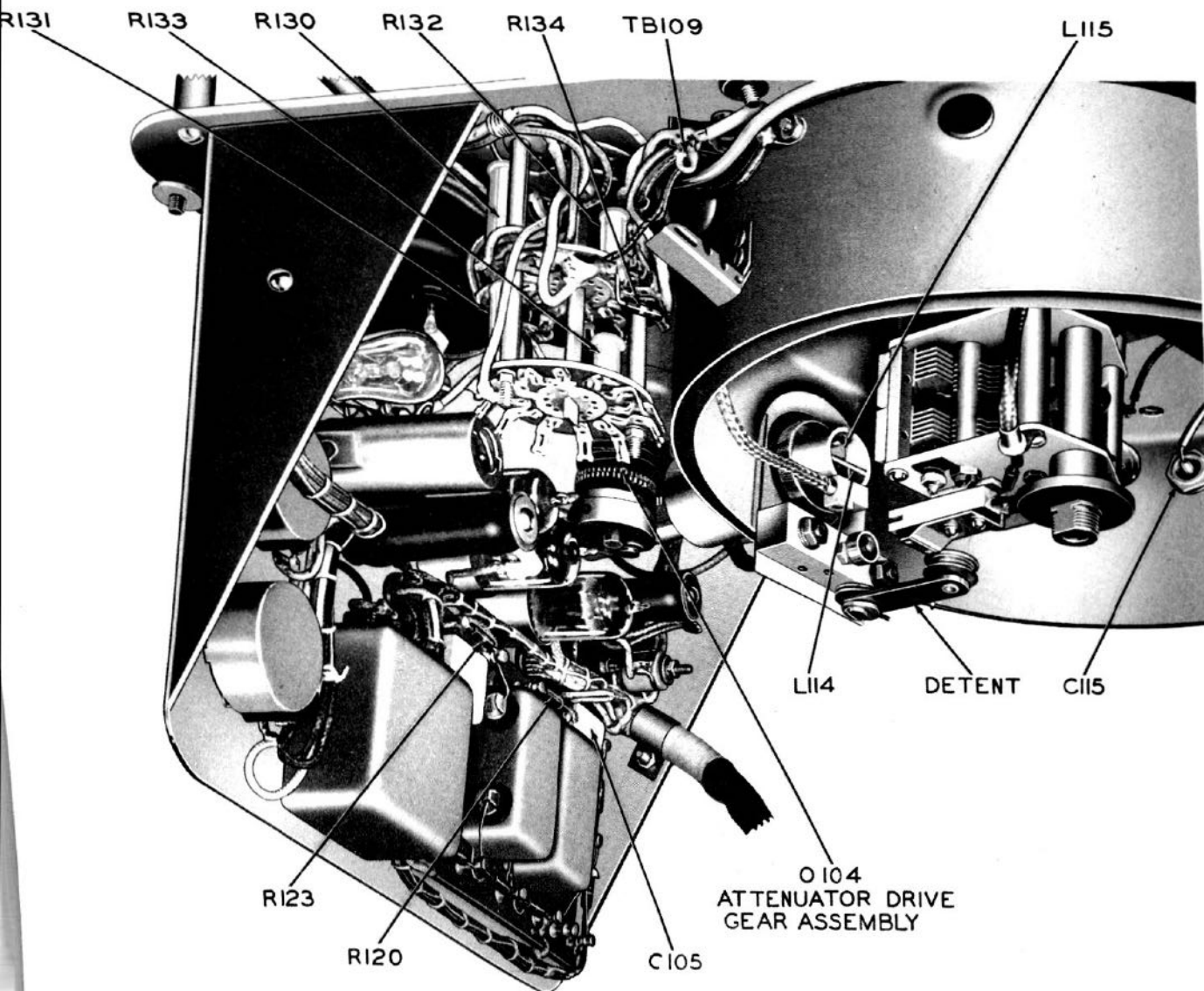


Figure 7-5. RF Signal Generator SG-45A/URM-26, Top View

(3) Adjust OUTPUT index until Barretter Bridge indicates signal generator output is 50,000 microvolts.

(4) Adjust OUTPUT CALIBRATION control R-126 (see figure 7-4) to bring pointer of meter M-101 to red line at center scale.

5. CALIBRATION OF PERCENTAGE MODULATION AND ZERO SET.

a. For correct indication of PERCENTAGE MODULATION on meter M-101, separate adjustments are required for zero and for full scale calibration.

b. Remove signal generator from its case and allow it to operate approximately 15 minutes before calibrating meter.

c. Connect an accurate dc voltmeter, such as Multimeter AN/PSM-4, and an ac vacuum tube voltmeter, such as Multimeter ME-25A/U, between ground and capacitor C-132, see figure 7-3.

(1) Voltage between C-132 and ground should be approximately 150 volts dc. If necessary readjust plate voltage in manner described in paragraph 2 of this section.

d. Set METER switch at % MOD.

e. Set AMPLITUDE MODULATION switch at OFF.

f. Adjust meter zero by means of % MOD ZERO resistor R-106.

g. Set AMPLITUDE MODULATION switch at either 400 or 1000.

h. Adjust % MOD control until rms voltage between C-132 and ground is .355 of the dc voltage between these terminals.

i. Adjust % MOD CAL control R-102 to produce full scale reading on meter M-101.

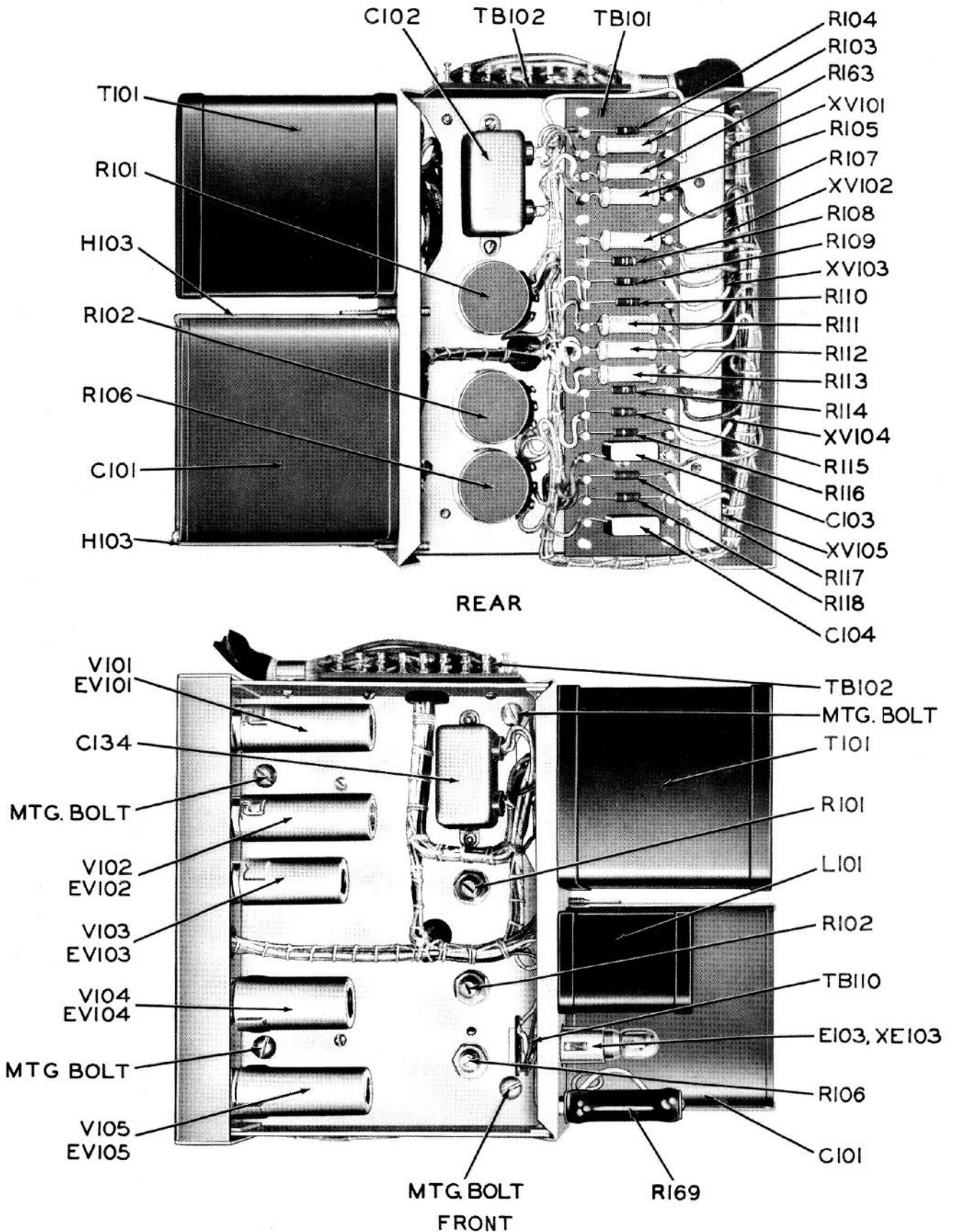


Figure 7-6. RF Signal Generator SG-45A/URM-26, Power Supply

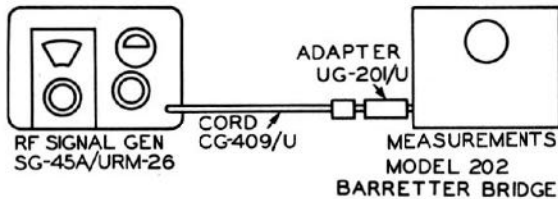


Figure 7-7. RF Signal Generator SG-45A/URM-26, Connections for Measuring Output Voltage

6. CHECKING FREQUENCY CALIBRATION.

a. The frequency characteristics of RF Signal Generator SG-45A/URM-26 are very stable and compensation for frequency shift will seldom be required. Replacement of the RF oscillator tube V-110, however, will usually modify circuit capacitance sufficiently to require compensation. Also, severe usage may loosen the screws holding the frequency dial resulting in the dial changing position sufficiently to cause the frequency calibration error to exceed the allowable tolerance of $\pm 0.5\%$. Tube replacements will affect calibration at the high frequency end of each scale but will have little if any effect on the accuracy of mid-scale or bottom-scale calibrations. Change of dial position, however, will result in a displacement of the calibration which will be evident at every point on the scale. The cause of error (capacitance change or dial displacement) should always be determined before making any adjustments.

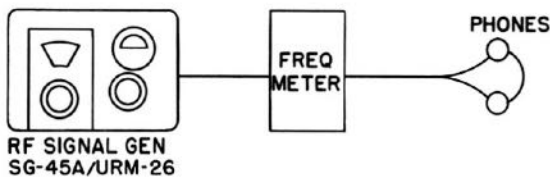


Figure 7-8. RF Signal Generator SG-45A/URM-26, Connections for Checking Frequency Calibration

b. **CHECKING PROCEDURE USING FREQUENCY METER:** Connect Signal Generator SG-45A/URM-26 to power source, place F range (180 Mcs to 405 Mcs) in operating position with modulation off. Allow instrument to operate about 15 minutes before starting frequency check then proceed as follows:

(1) Connect output connector J-106 to a heterodyne frequency meter that covers the required frequency range, such as Frequency Meter TS-186/UP (see figure 7-8).

(2) Start at 180 megacycles and check for zero beat every 10 megacycles to 400 megacycles, noting, at each beat, the relative position of the index line and calibration mark.

(a) If, at each zero beat, the dial calibration relative to the index line is displaced approximately

the same angular amount and in the same direction it is likely that the mechanical position of the frequency dial should be reset.

(b) If, at each zero beat, the dial calibration and index line coincide at the lower frequencies and diverge as the high frequency end of the scale is approached, it is apparent that circuit capacitance has changed.

Note

The conclusions reached in (a) or (b) above should be verified by making similar checks on the lower frequency ranges using a suitable frequency meter (e.g. Frequency Meter AN/USM-29 or LR series). At lower frequencies 1 megacycle or tenth-megacycle check points will be found more convenient.

(c) If results obtained on lower frequency ranges do not check those obtained on F range, oscillator coil assemblies should be examined for possible damage.

c. **RESETTING DIAL:** When tests described in paragraph b above indicate that the position of the frequency dial has changed, proceed as follows:

(1) Loosen the two #10 Allen set screws which secure tuning dial I-102 and remove dial from shaft.

(2) Loosen the two #10 Allen set screws which secure RANGE knob E-107 and remove knob.

(3) Remove four screws holding dial cover H-104, see figure 7-9, and remove cover.

(4) Remove Dial Mask I-105. This mask is secured to shaft by two #4 Allen set screws.

CAUTION

DO NOT TOUCH CALIBRATED FACE OF DIAL AS THE MARKS MAY SMEAR.

(5) Loosen three screws which secure frequency dial, rotate dial as required to correct observed frequency error then retighten screws.

(6) Recheck calibration at low- and high-frequency ends of F range.

Note

The frequency dial should be set so coincidence of calibration and index lines occur at 180 megacycles. A small deviation at the high frequency end of scale may be compensated by means of the trimmer adjustment described in paragraph 6d of this section.

(7) After final adjustment is made, replace dial mask, dial cover and knobs.

d. **CORRECTING FOR SMALL CAPACITANCE CHANGE:** A small trimmer is included in the tuning capacitor assembly to provide correction of approximately ± 5 megacycles at 400 megacycles, sufficient to provide for tube variations. When tests in paragraph b above indicate a small circuit capacitance change, proceed as follows:

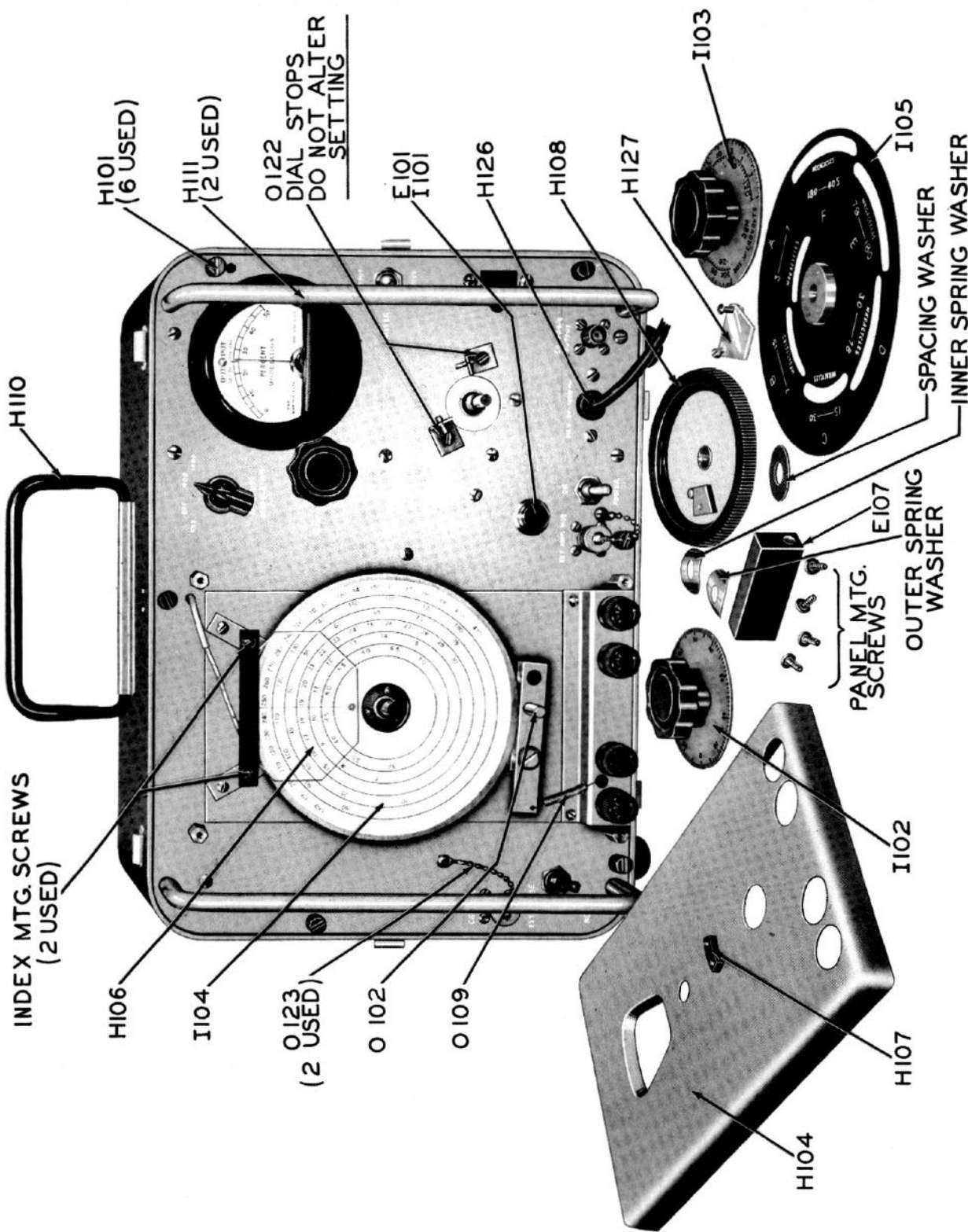


Figure 7-9. RF Signal Generator SG-45A/URM-26, Partial Disassembly, Front Panel

(1) Remove instrument from case (see paragraph 7-1e).

(2) Unfasten three spring latches that hold outer oscillator shield in place, then remove both outer and inner shields.

(3) Check each 10-megacycle calibration point between 200 and 400 megacycles, as previously described in paragraph *b* above, to determine the direction of the frequency error (above or below the scale calibration).

(4) When the zero beat corresponding to the 400-megacycle calibration is obtained, note relative position of index line and calibration. If the frequency reading is high, circuit capacitance must be reduced and vice versa.

(5) Access to a small trimmer capacitor, C-128D, is provided by the small hole in the coil disc, when "F" band is connected, see figure 7-10. Insert a 1/4 inch socket wrench and adjust trimmer capacitor to zero beat while slowly rotating tuning dial until 400-megacycle calibration is correct. Clockwise rotation of trimmer increases capacitance.

Note

If the trimmer cannot fully correct the calibration error, replacement of oscillator tube V-110 may be effective.

(6) Recheck calibration of low- and mid-frequency points to make certain it is within tolerance.

(7) Replace inner oscillator shield so that its grounding wiper lies toward the top of the front panel on the coil disc. Alignment marks are provided on both inner and outer shields to facilitate replacement.

(8) Replace outer oscillator shield; the spring latches have two locking slots of which the one nearer the pivot is ordinarily used.

(9) Place instrument in case and tighten the six captive bolts.

**7. REPLACEMENT OF OSCILLATOR COIL
SUB-ASSEMBLY.**

a. Oscillator coils used in the oscillator system of RF Signal Generator SG-45A/URM-26 are ruggedly constructed and, being completely shielded mechanically, are seldom damaged. Repair or replacement is, therefore, rarely required. To remove a coil, either for repair or replacement:

(1) Remove instrument from case (see paragraph 7-1e).

(2) Unfasten three latches that hold outer shield and remove both outer and inner shield covers (see figure 7-10).

(3) Remove two screws holding Spring O-114 and Roller O-113. Be careful not to lose roller as roller shaft is not attached permanently to the Spring.

(4) Turn coil mounting disc to position midway between detents and, while holding disc firmly in this position, remove the one-inch nut H-116 which holds disc. Push detent away and lift coil mounting disc straight out.

(5) Remove two screws holding the oscillator sub-assembly to be removed (see figure 7-11). If sub-assembly for band A, band E, or band F is to be removed, it is also necessary to unsolder the shield where it is attached to the neighboring sub-assembly.

CAUTION

COILS FOR RANGES A THROUGH D ARE HELD IN POSITION BY CLAMPS AT EACH END OF COIL FORM (SEE FIGURE 7-11). CARE MUST BE TAKEN NOT TO LOOSEN THESE CLAMPS WHEN MAKING REPAIRS AS THE POSITION OF THE COIL RELATIVE TO PICK-UP LOOPS L-114 AND L-115 WILL BE CHANGED AND ITS CALIBRATION DESTROYED.

(6) After oscillator sub-assembly has been repaired, remount it on coil mounting disc.

(7) Replace coil mounting disc on its shaft, being careful that:

(a) Disc is midway between detent positions.

(b) Flat on shaft is parallel with flat side of hole in disc.

(c) Detent roller is properly engaged with edge of disc.

(8) Replace and tighten one-inch nut.

(9) Replace roller O-113, and spring O-114, and attach the two screws to secure the spring.

(10) Check frequency range of repaired sub-assembly (see paragraphs 7-6 and 7-12).

(11) Check output voltage at .05 volt level using the set-up shown in figure 7-7. If, with output meter set to red line, the error in output voltage exceeds allowable tolerance, proceed as follows:

(a) OUTPUT VOLTAGE LESS THAN .05 VOLT: Loosen screws holding coil-form clamp (figure 7-11), then move coil slightly towards front panel.

(b) Tighten clamp screws and recheck output voltage.

(c) Repeat steps (a) and (b) above until output is within tolerance.

CAUTION

TO AVOID UPSETTING THE OUTPUT CALIBRATION OF OTHER COIL RANGES, DO NOT RE-ADJUST OUTPUT CALIBRATION RESISTOR R-126 TO SUIT NEW OR REPAIRED COIL.

(d) OUTPUT VOLTAGE MORE THAN .05 VOLT: Loosen screws holding coil-form clamps (figure 7-11) then move coil slightly towards coil disc.

(e) Repeat procedures described in (b) and (c) above.

b. Replace oscillator shields, positioning them by alignment marks, and place instrument in case.

c. Tighten captive bolts holding panel.

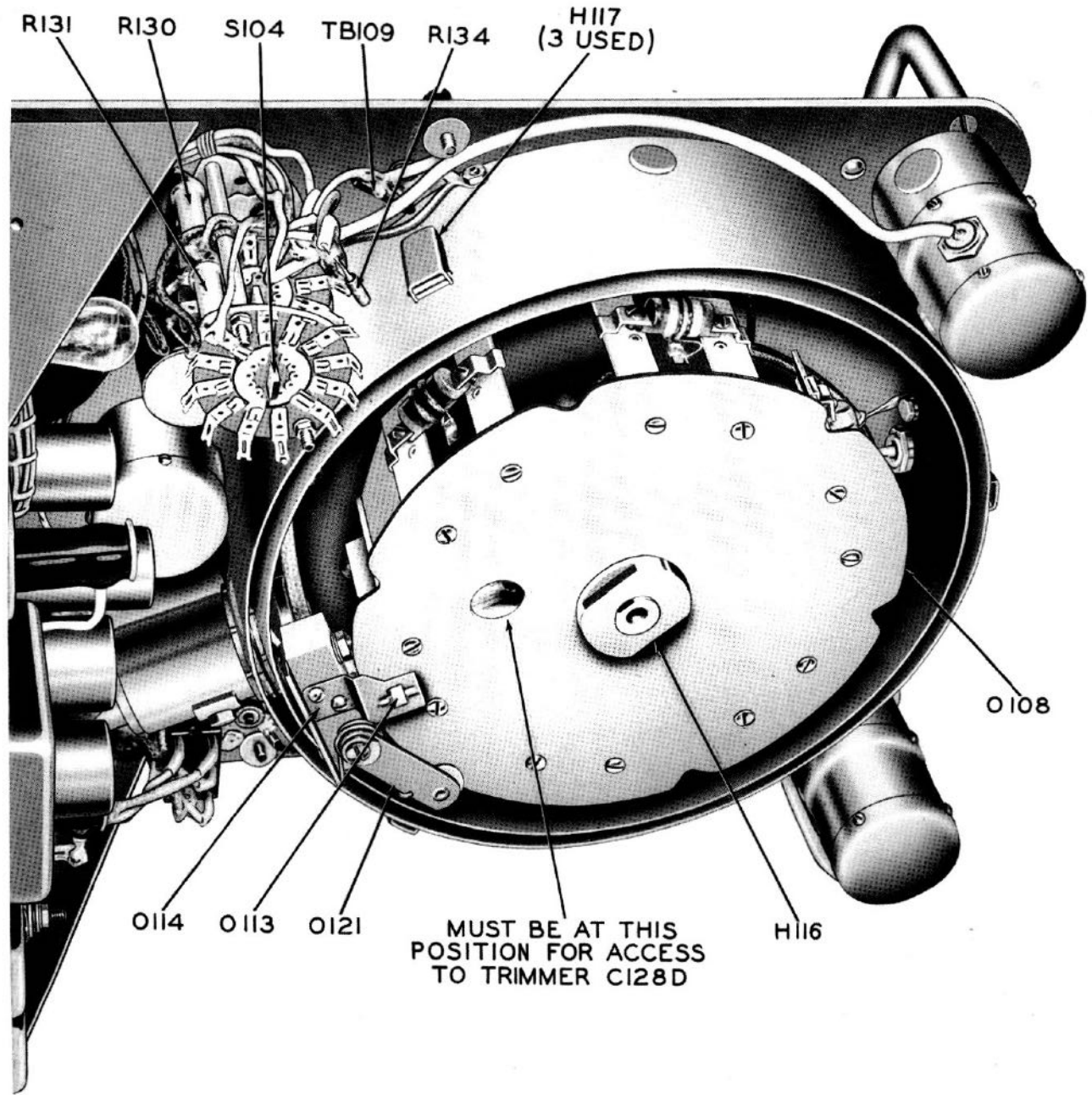


Figure 7-10. RF Signal Generator SG-45A/URM-26, Oscillator Compartment, Interior

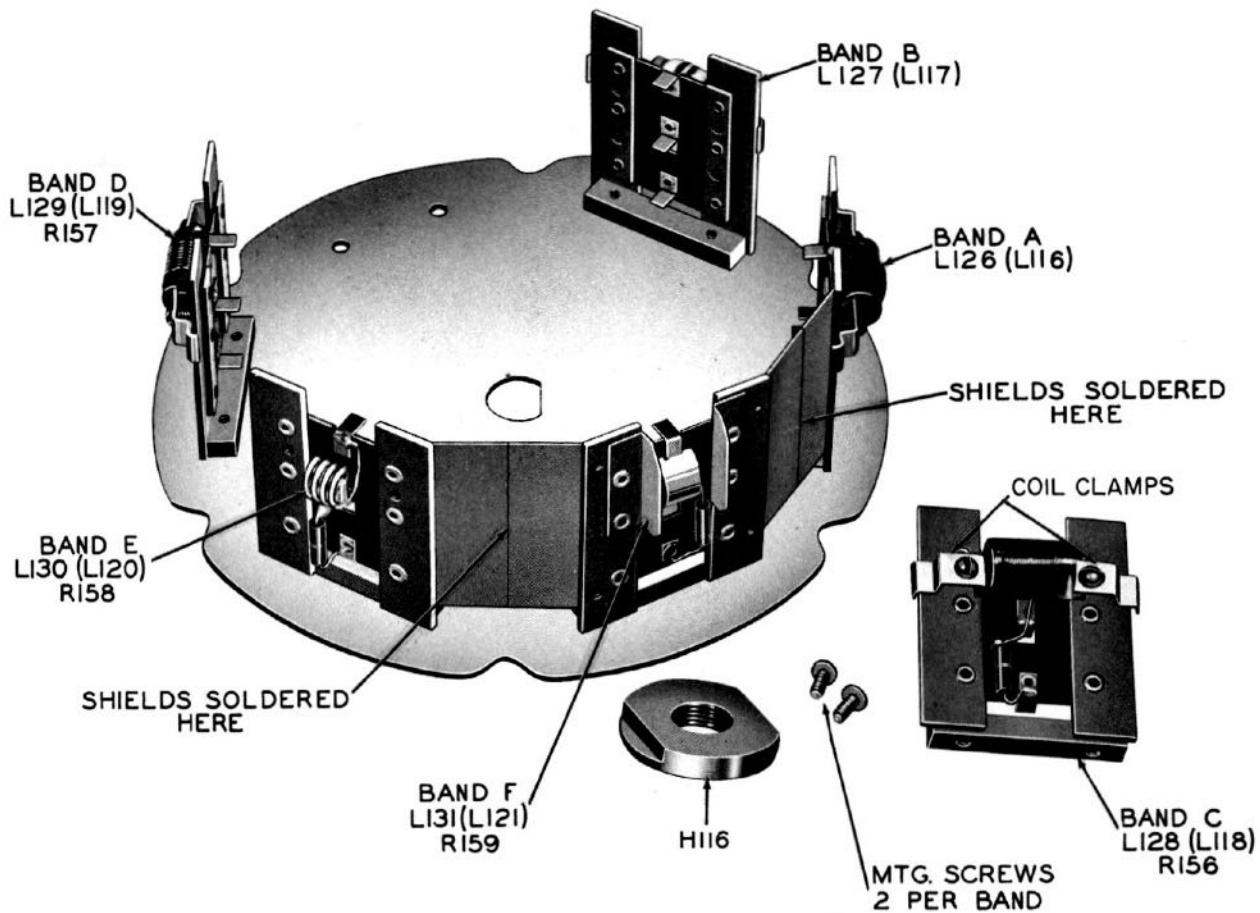


Figure 7-11. RF Signal Generator SG-45A/URM-26, Coil Disc Assembly

8. REPLACING BOLOMETER ASSEMBLY.

CAUTION

TO AVOID BURNOUT OF BOLOMETER WHEN CHECKING CONTINUITY, BE SURE THAT NO MORE THAN 1 MILLI-AMPERE IS PASSED THROUGH THE BOLOMETER. CONTINUITY MAY BE CHECKED USING AN OHMMETER THAT HAS A ZERO RESISTANCE CURRENT OF NOT MORE THAN 1 MILLI-AMPERE.

a. Replacement of individual bolometers is not recommended as these units are factory matched for similar thermal characteristics. The matching procedure requires special equipment and is not a practicable field operation. Furthermore, bolometer R-151 in parallel with resistor R-150 terminates monitor cable W-104 and any variation in their shunt value will introduce error in output voltage. Resistor R-150 must be adjusted as explained below, otherwise error in output voltage indication may be as great as 25%. The recommended procedure, therefore, is to install resistor Kit R-174, which consists of factory matched bolometers and resistor R-150. Note specifically sub-paragraphs (17) and (19):

- (1) Remove instrument from case (see paragraph 7-1e).
- (2) Unfasten three latches that hold outer shield and remove both outer and inner shields.
- (3) Remove dial cover following instructions of paragraph 7-6c.
- (4) Unsolder connection to bolometer R-155 at terminal board TB-109, see figure 7-12, and pull lead through front panel.
- (5) Remove two screws holding spring O-114 and roller O-113; be careful not to lose roller as roller shaft is not permanently attached to spring.
- (6) Place coil mounting disc approximately midway between detent positions and, holding disc firmly, remove 1-inch nut, H-116, holding coil assembly.
- (7) Disengage detent roller from coil disc then remove coil assembly being careful not to damage contacts.
- (8) Remove two screws holding bolometer assembly (see figure 7-12).
- (9) Unsolder connection at capacitor C-115.
- (10) Loosen clamp holding cable W-104 and lift bolometer assembly out of oscillator shield.
- (11) Loosen the three set screws which hold capacitors C-116 and C-131 and cable W-104 (see figure 7-12).

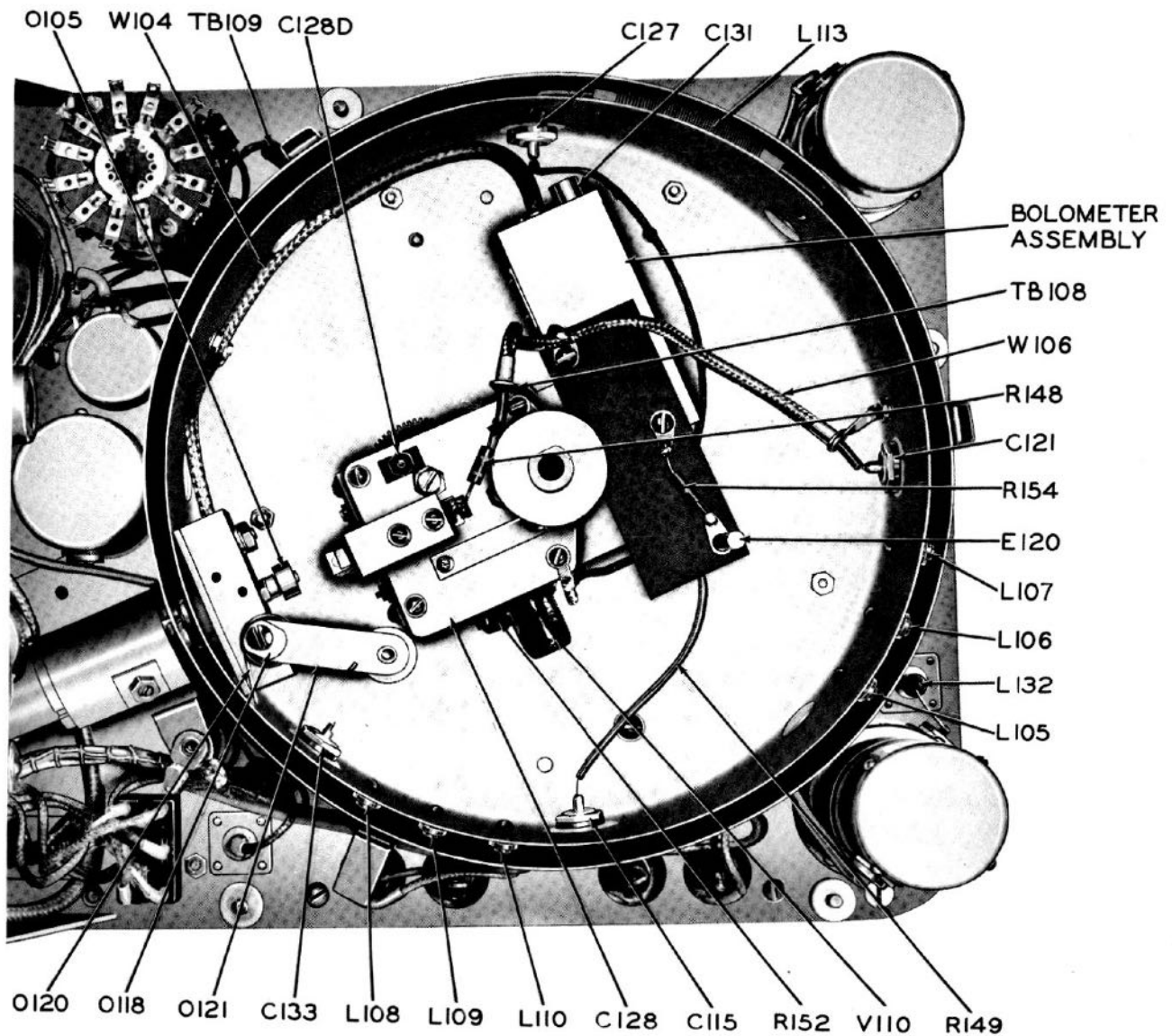
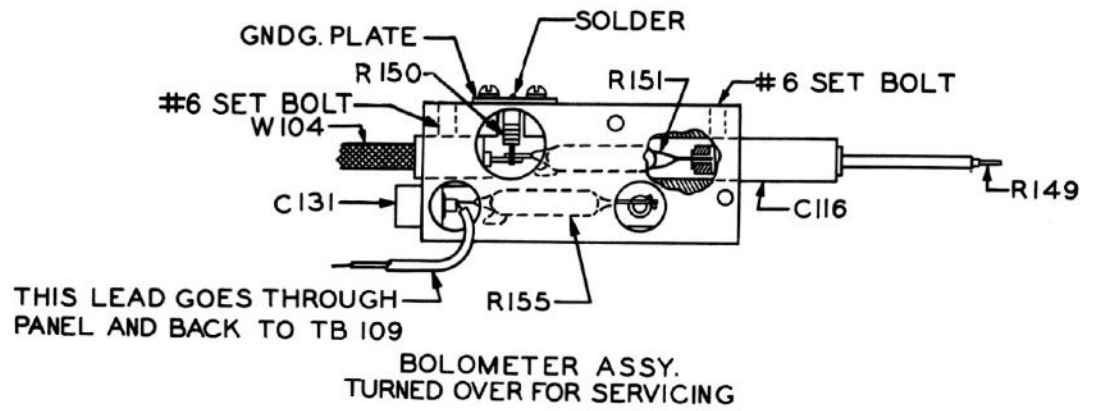


Figure 7-12. RF Signal Generator SG-45A/URM26, Oscillator Compartment Showing Bolometer

ORIGINAL

(12) Remove the two screws that hold the grounding plate at resistor R-150.

(13) Unsolder bolometer R-155 from its grounding terminal and remove the bolometer by withdrawing capacitor C-131.

CAUTION

AVOID PROLONGED APPLICATION OF SOLDER IRON. HEAT MAY DAMAGE INTERNAL INSULATION OF CABLE AND PERMANENTLY CHANGE VALUE OF COMPOSITION RESISTOR.

(14) Unsolder junction of cable W-104, resistor R-150, and bolometer R-151 and remove cable and resistor. Bolometer may be removed by withdrawing capacitor C-116.

(15) Unsolder bolometers from capacitors.

(16) Unsolder resistor R-150 from its grounding plate.

(17) After careful reading of tags on bolometers, giving required value of resistor R-150, install new bolometers and resistor.

(18) Connect end of cable W-104 and tighten all three set screws in bolometer assembly.

(19) Insulate resistor R-150 grounding plate from the block and adjust the resistor to the value required. Scraping the surface of the resistor with a file or hand grinder will increase its resistance. After adjustment coat resistor with fungicidal varnish.

(20) Remove insulation and remount grounding plate with two screws.

(21) Restore bolometer assembly and other apparatus.

(22) Replace dial cover, range knob and tuning dial.

(23) Check output voltage as described in paragraph 7-4. If coil positions have not been disturbed, minor errors in output voltage calibration may be corrected by means of OUTPUT CALIBRATION resistor R-126. If the output voltage on a coil range differs considerably from the average, readjustment of coil position, as previously described in paragraph 7 of this section, will be necessary.

(24) Replace oscillator shields, place instrument in case and tighten captive bolts.

9. REPLACING FILTER COILS L-105 THROUGH L-110.

a. These coils are mounted between the side walls of the inner and outer oscillator shields. Each coil is supported by a screw which passes through the inner shield into the tapped coil form, see figure 7-12. Coils L-105, L-106 and L-107 in series form the plate filter inductance while coils L-108, L-109 and L-110 form a filter section for one arm of the bolometer bridge.

b. Whenever one coil is to be replaced, the three coils forming one section must be removed simultaneously. Proceed as follows:

(1) Remove instrument from case (see paragraph 7-1e).

(2) Unfasten three spring latches that hold outer shield and remove both outer and inner shields.

(3) Remove coil mounting disc (see figure 7-10 and paragraphs 7-8a(4), 7-8a(5), and 7-8a(6)).

(4) Remove plug buttons adjacent to each end coil and unsolder coil connection at each end.

(5) Remove the three mounting screws.

(6) The three coils may now be removed and the defective coil replaced. Keep lead lengths same as in original assembly.

(7) Replace the coils as in their original position.

(8) Solder free leads of first and last coils and replace plug buttons.

(9) Remount coil mounting disc, replace oscillator shield covers, and restore instrument to case.

10. REPLACING ATTENUATOR COMPONENTS.

a. Output cable, W-105, may become defective due to continual flexing. Resistor R-176 may be damaged. Cable Assembly W-107 (which includes both W-105 and R-176) should be installed if either W-105 or R-176 needs to be replaced. The plunger may be damaged sufficiently to require replacement. The procedure for replacing any of these components is as follows:

(1) Place range switch midway between operating (detented) positions.

(2) Remove instrument from case and remove oscillator shields.

(3) Remove electron tube V-109.

(4) Loosen clamp which holds output cable W-105 and disassemble cable from OUTPUT connector J-106 (see figures 7-4 and 7-19).

(5) Loosen two set screws holding MICRO-VOLTS dial.

(6) Slide plunger out of attenuator.

(7) Loosen two set screws in plunger (see figure 7-13).

(8) Unsolder loop L-115 (outer end of resistor R-176) from the pin which is a permanent part of the plunger.

(9) Remove resistor and cable by pushing them through the loop end of plunger.

(10) If either resistor R-176 or cable W-105 is defective, install a new cable assembly W-107 (comprising both R-176 and W-105 together with splicing sleeve and insulating sleeve).

(11) Insert cable assembly W-107 into plunger by pushing cable through plunger from loop end.

(12) Solder pre-formed end of resistor R-176 to end of grounding pin in plunger.

CAUTION

GRASP LOOP WITH BROAD-BILL PLIERS AND DO NOT HOLD IRON ON CONNECTION LONGER THAN NECESSARY AS EXCESSIVE HEAT MAY CAUSE VALUE OF R-176 TO INCREASE.

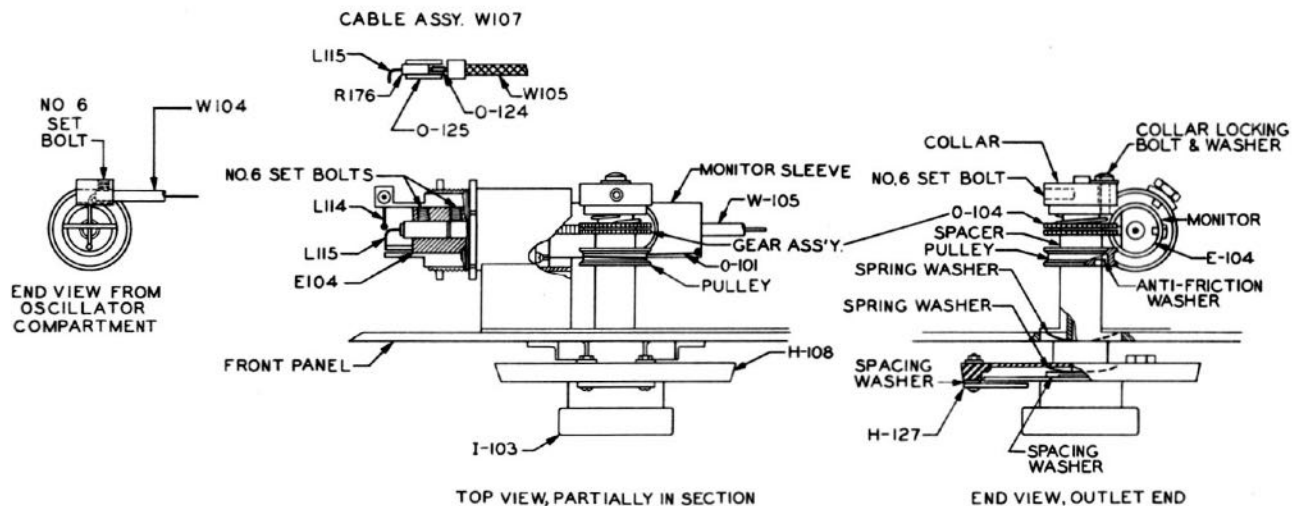


Figure 7-13. RF Signal Generator SG-45A/URM-26, RF Attenuator

(13) Tighten two set screws to secure resistor R-176 and cable assembly W-105 (see figure 7-13).

(14) Replace plunger in attenuator tube until gear rack on plunger almost engages drive gear.

(15) Wind spring-loaded gear about five teeth and slide plunger gear rack into engagement.

(16) Rotate OUTPUT index control clockwise to stop and hold in that position.

(17) Move plunger to bring output loop L-115 into exact alignment with monitor loop L-114.

(18) Grasp gears and pulley to hold loops in alignment.

(19) Rotate MICROVOLTS dial to its extreme clockwise position and press dial toward panel to provide clearance between dial and index plate. Tighten two set screws in MICROVOLTS dial knob.

(a) Check MICROVOLTS dial friction to make certain pressure exerted by friction washers is not sufficient to cause movement of movable index when dial is rotated. If friction is too great it may be reduced by bringing dial forward on shaft.

(20) Loop output cable once around drive shaft hub, reassemble cable into OUTPUT connector J-106 and replace cable clamp.

(21) Recheck alignment of pick-up and monitor loop. If not in exact alignment:

(a) Loosen screw in adjustment disc on rear of gear shaft (see figure 7-5).

(b) Rotate gears to bring loops into alignment while holding MICROVOLTS dial with 50K calibration line at index, then tighten screw.

(22) Remount tube V-109 and shield EV-109.

(23) Replace oscillator shields, then recalibrate output voltage as described in paragraph 7-4.

(24) Replace instrument in case and tighten captive bolts.

11. REPLACING TUNING CAPACITOR.

a. Remove instrument from case, then remove coil assembly and oscillator tube V-110, following instruc-

tions of paragraphs 7-1e and 7-7a.

b. Unsolder resistor R-148 at connection to capacitor C-128A (see figure 7-12).

c. Unsolder heater connection at socket of tube V-110.

d. Remove screw holding terminal board TB-108.

e. Remove tuning dial, range knob, dial cover, dial mask, index plate and frequency dial following instructions in paragraph 7-6c.

f. Remove two nuts and four screws holding tuning capacitor (see figure 7-14).

g. Install new tuning capacitor.

h. Resolder all connections.

i. Replace tube and coil assembly.

j. The installation of a new tuning capacitor will necessitate frequency recalibration. The procedure for recalibrating the frequency scale is described in paragraph 12 of this section.

12. FREQUENCY RECALIBRATION.

a. RF Signal Generator SG-45A/URM-26 may be recalibrated with the aid of a suitable frequency meter (see table 7-2). Recalibration will be required whenever the frequency error exceeds 0.5%. Replacement of an oscillator coil with a new coil will usually require a new calibration for the range affected.

b. Dial calibration marks may be erased from the frequency scale by means of a soft rubber eraser and this is recommended whenever a single range is to be recalibrated. Whenever recalibration of all ranges is required it will be more convenient to replace the old dial with a new dial (reference symbol I-104). Access to the tuning dial is provided as follows:

(1) Remove selector knob, E-107, and drive dial, I-102, by loosening set screws (see figure 7-9).

(2) Remove dial cover, H-104, which is attached by four binding head screws.

(3) Remove dial mask, I-105, by loosening set screws.

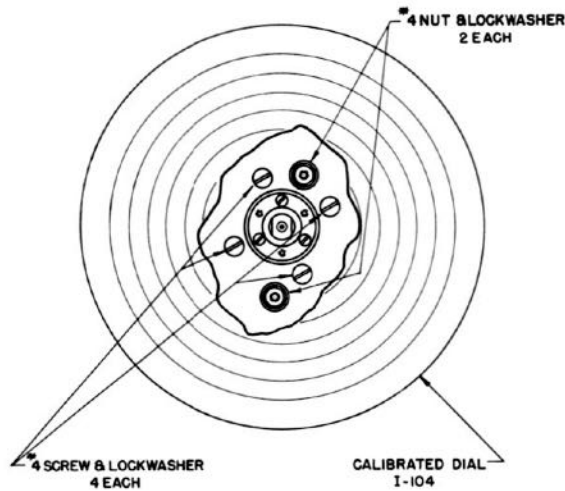


Figure 7-14. RF Signal Generator SG-45A/URM-26, Tuning Capacitor Mounting

(4) Remove index plate by taking out two screws.

(5) Tuning dial can then be removed by taking out three screws.

c. A dial calibration jig, O-126, provides a straight-edge guide for marking the dial. This jig is available from stock spares. Mount the jig in front of the dial in the position normally occupied by the index plate, taking care to have the guiding edge properly aligned so that the markings will be radial.

d. The recommended set-up for frequency recalibration is shown in figure 7-15. The frequency meter should be suitable for the range to be calibrated. The calibration procedure is as follows:

(1) Connect RF Signal Generator SG-45A/URM-26 to power source and allow instrument to operate at least fifteen minutes before calibrating. Set range selector for band being calibrated and place AMPLITUDE MODULATION switch at OFF.

(2) Connect output connector, J-106, to the heterodyne frequency meter in use.

(3) Connect headphones to heterodyne frequency meter for aural monitoring of beat note.

(4) Set frequency meter to the highest major frequency calibration of the range being calibrated (see figure 7-16).

(5) Rotate tuning dial, I-104, to high frequency end of range and tune carefully for zero beat with frequency meter.

(a) Mark scale calibration with a sharp, hard-lead pencil.

Note

Major interval calibration lines should be $\frac{1}{8}$ inch long, while minor interval lines should be $\frac{1}{16}$ inch long.

(6) Proceed as in paragraphs (4) and (5) until all major and minor frequency intervals are marked on frequency dial.

(7) Add numerals to identify major scale divisions.

e. Remount index plate in place of calibrating jig and check alignment of index plate at any convenient frequency point.

13. REPLACING ATTENUATOR DRIVE CABLE.

a. The metal drive cable which adjusts the position of the monitor loop may be broken. A new cable may be installed, by the following procedure (see figures 7-5 and 7-13).

CAUTION

NEVER PERMIT EITHER MONITOR LOOP (L-114) OR ATTENUATOR LOOP (L-115) TO COME IN CONTACT WITH AN OSCILLATOR COIL.

(1) Remove instrument from case (see paragraph 7-1e).

(2) Unfasten three spring latches that hold outer shield and remove both outer and inner shields.

(3) Rotate movable index counter-clockwise to stop and unsolder cable from attenuator tube.

(4) Unsolder cable from pulley and wipe pulley clean of excess solder.

(5) Pull attenuator tube out as far as possible and lift inner end of cable from slot. This end of cable is anchored by means of a small eyelet which is soldered to the cable.

(6) Insert eyeletted end of new cable into slot in attenuator tube and loop cable once around pulley.

(7) Switch band "A" coil into operating position.

Note

Clearance between attenuator loops and band "A" oscillator coil assures clearance for switching all other bands. Clearance for band "A" should approximate $\frac{1}{32}$ inch.

(8) Rotate both movable index and MICRO-VOLTS dial clockwise to their stops.

(9) Move attenuator tube by hand to bring monitor loop into exact alignment with output loop. Stretch cable to a tension of seven pounds as measured with a spring scale. This tension shall be applied parallel to axis of attenuator tube.

(10) Solder cable to tube and then cut off excess cable.

(11) Make certain that both index and MICRO-VOLTS dials are at clockwise stops and that monitor loop and output loop are in exact alignment.

(12) Solder cable to pulley at original location.

b. Examine all oscillator coils for damage incurred during the period the attenuator cable was broken. If replacement of any coil is required refer to paragraphs 7-7 and 7-12.

c. Replace oscillator shield covers and restore instrument to case.

d. Recheck output voltage calibration (see paragraph 7-4).

14. REPLACEMENT OF OSCILLATOR TUBE.

- a. Remove instrument from case (see paragraph 7-1e).
- b. Unfasten three spring latches that hold outer shield and remove both outer and inner shields.
- c. Remove coil assembly (see paragraph 7-7a. The oscillator tube is now available for replacement, (see figure 7-12).

d. After a new tube is installed the frequency calibration for range F should be checked following the procedure described in paragraph 7-6. Any difference between tube capacitances of the old and new tubes will modify the high frequency calibration but will have negligible effect on the calibration at the low frequency end of the scale.

e. Replace oscillator coil shields and restore instrument to case.

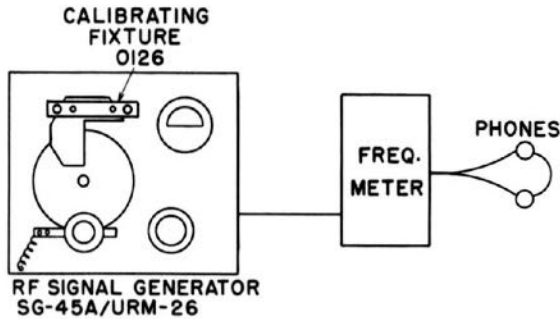


Figure 7-15. RF Signal Generator SG-45A/URM-26, Recalibration Set-up

15. REPAIR OF BOLOMETER FILTER.

a. Bolometer filter components C-113, C-114, and L-102 are housed in a cylindrical shield at the rear of the instrument front panel and adjacent to the attenuator (see figures 7-3 and 7-17).

b. For access to L-102 and one end of C-113 and one end of C-114, remove three small self-tapping screws from shield cover and lift cover off.

c. Capacitor C-114 bolts through filter shield and outer oscillator shield.

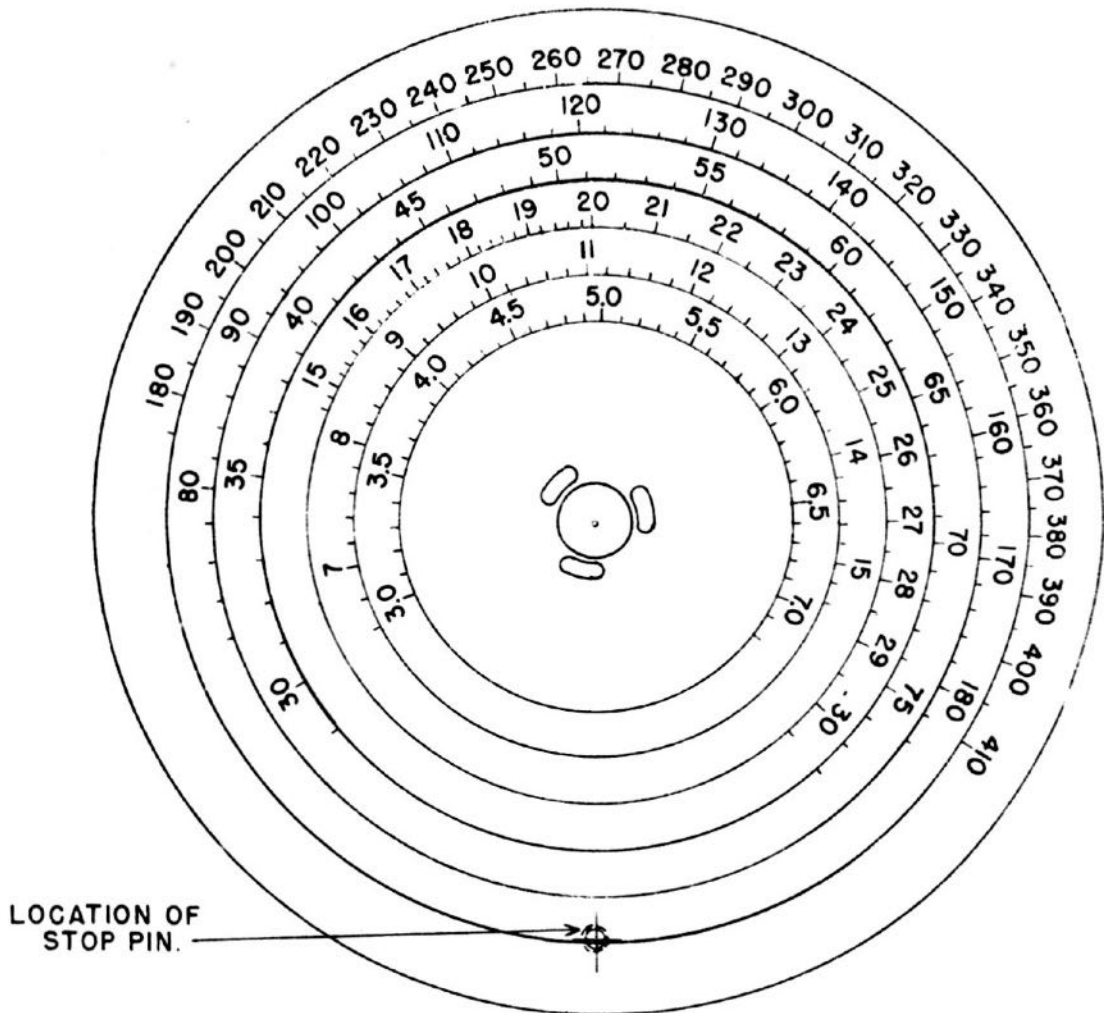


Figure 7-16. Signal Generator SG-45A/URM-26, Typical Dial Calibration

16. REPAIR OF OSCILLATOR HEATER FILTER.

a. The oscillator heater filter components C-122, C-123, C-124, C-125, C-126, L-111, and L-112 are housed in a double-deck cylindrical shield at the upper rear of the panel. See figures 7-3 and 7-17.

b. Capacitor C-124 bolts upper shield and lower shield cover together.

c. Capacitor C-126 is bolted through lower shield and outer oscillator shield.

d. For access to C-122, C-123, L-111, and upper end of C-124, remove three small self-tapping screws in the top shield cover and lift cover off.

e. For access to C-125, C-126, L-112, and lower end of C-124, remove three small self-tapping screws from lower shield cover and lift upper shield carefully so as not to put strain on internal wire connections.

17. REPAIR OF OSCILLATOR PLATE SUPPLY FILTER.

a. Oscillator plate supply filter components are housed in a three-deck cylindrical shield on the lower rear of the instrument front panel (see figures 7-3 and 7-17).

(1) Coil L-122 and one end of capacitor C-132 are housed in upper compartment.

(2) Capacitor C-117 bolts upper shield to center shield cover.

(3) Capacitor C-118 bolts center shield to lower shield cover.

(4) Coil L-103, lower end of C-117, and upper end of C-118 are housed in center compartment.

(5) Coils L-104 and L-133, Resistor R-147, one end of capacitors C-119 and C-120, and body of switch S-103 are housed in lower compartment.

(6) Capacitor C-120 bolts through lower shield and outer oscillator shield.

(7) Switch S-103 bolts through lower shield and instrument front panel.

b. For access to upper compartment, remove three small self-tapping screws from top cover and lift cover off.

c. For access to center compartment, remove three small self-tapping screws from center cover and lift upper shield carefully to avoid strain on internal wires.

d. For access to lower compartment, remove four small self-tapping screws from lower cover and lift upper shields carefully to avoid strain on internal wires.

18. REPLACEMENT OF COIL L-113.

a. Coil L-113 is mounted between the inner and outer oscillator shields (see figure 7-12).

b. Remove plug button at each end of coil.

c. Unsolder coil leads.

d. Loosen bolt at each end of coil and slip coil out from under the mounting clips.

19. REPLACING RESISTORS IN FIXED ATTENUATOR CN-179/URM-26A.

a. When any one of the three resistors (R-301, R-302 and R-303) which form Fixed Attenuator CN-179/URM-26A requires replacement it will be best to remove all three replacing them with new resistors. Proceed as follows:

(1) Remove three 6-32 screws which attach both halves of the housing and the six small screws which secure the end plates and grounding plates to the upper half of the assembly. The upper half may now be removed (see figure 7-18).

(2) Unsolder and remove all resistors being careful not to damage the small spacer washer on each resistor.

(3) Place one spacer washer on each of the new resistors then install the resistors in their proper positions and resolder. Do not use excessive heat when making these connections.

(4) Allow a few minutes for resistors to attain room temperature then remove two remaining screws in the grounding strips and insulate strips from lower half of block by means of a thin sheet of paper. Check individual resistors for compliance with the following values:

| | |
|-------|---------------------|
| R-301 | 247.0 ohms \pm 2% |
| R-302 | 61.1 ohms \pm 2% |
| R-303 | 61.1 ohms \pm 2% |

Note

RESISTORS THAT ARE BELOW RATED VALUE MAY BE ADJUSTED BY SCRAPING THE SURFACE OF THE RESISTIVE ELEMENT WITH A FILE OR HAND GRINDER; THE RESISTOR SHOULD THEN BE COATED THOROUGHLY WITH FUNGICIDAL VARNISH. RESISTORS THAT EXCEED THE ALLOWABLE POSITIVE VALUE SHOULD BE REPLACED.

(5) Reassemble block and restore all screws.

(6) Measure the resistance from the center terminal of each connector to ground. When all resistors are within tolerance the measured resistance, from either connector, will be 51 ohms \pm 2%.

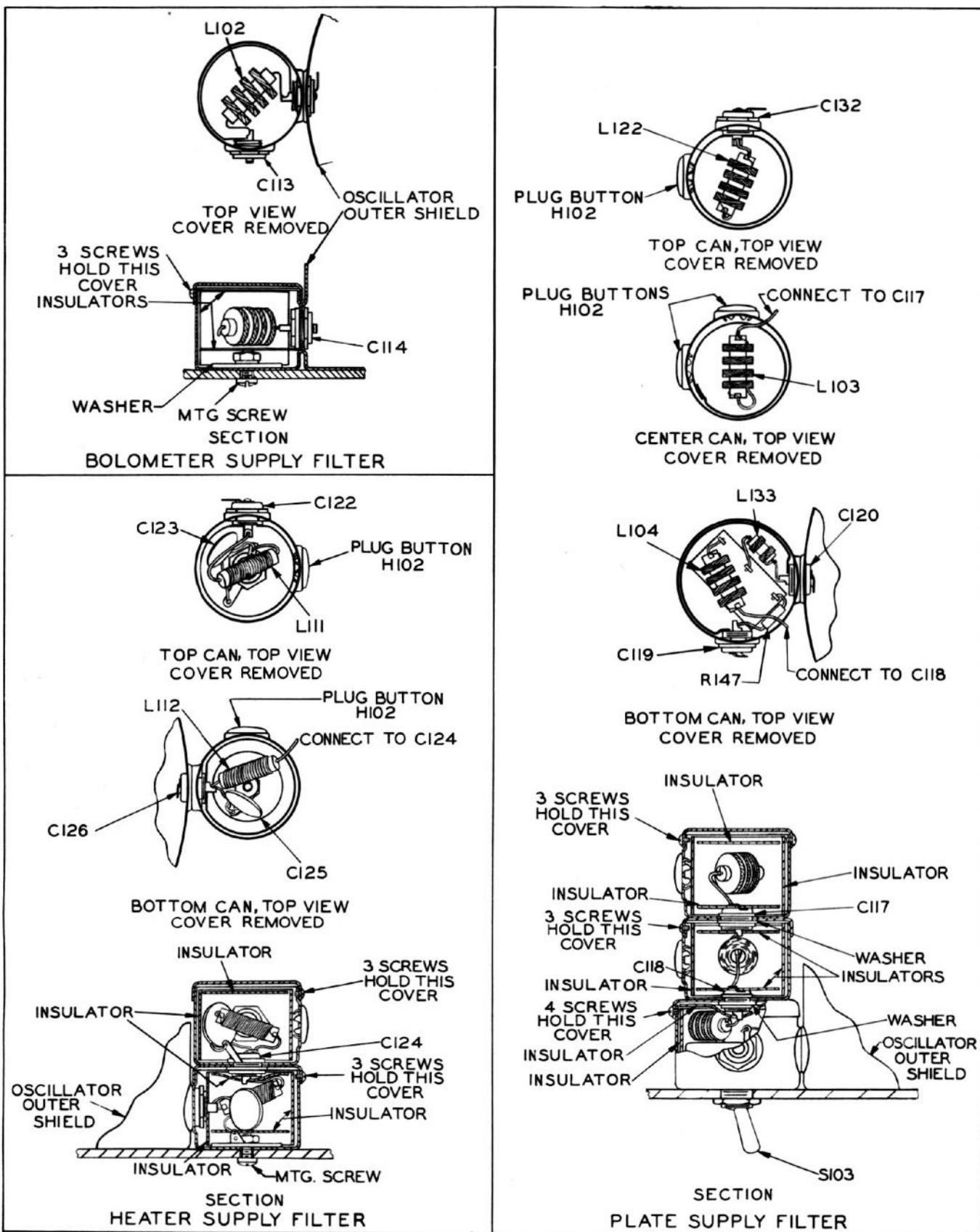
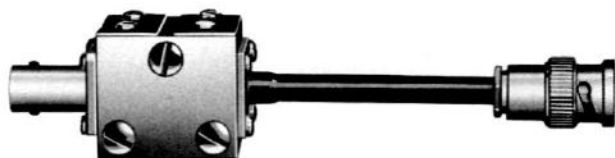
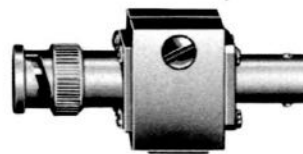


Figure 7-17. RF Signal Generator SG-45A/URM-26, RF Filters



FIXED ATTENUATOR
CN-179/URM-26A



TEST ADAPTER
MX-1289/URM-26A

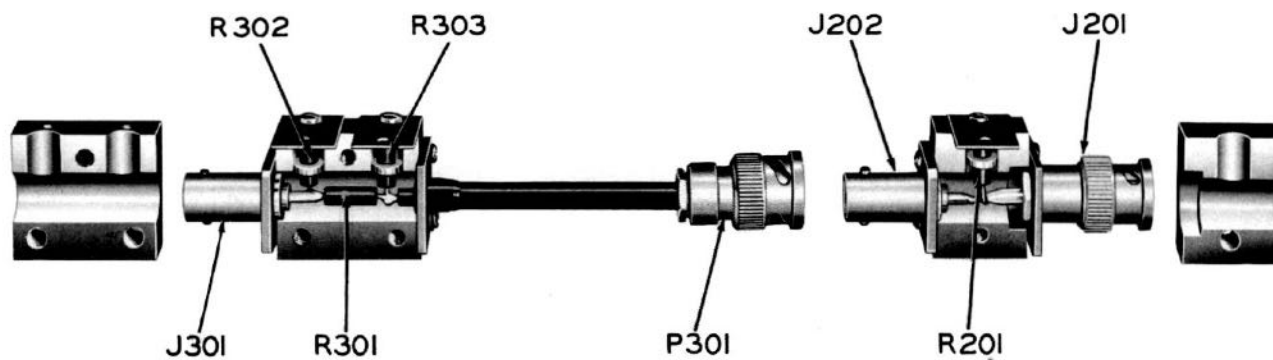


Figure 7-18. Fixed Attenuator CN-179/URM-26A and Test Adapter MX-1289/URM-26A

20. REPLACING RESISTOR IN TEST ADAPTER MX-1289/URM-26A.

a. Remove the screw which attaches both halves of the block and the small screws which secure the connectors and grounding spring to the upper plate. The upper half of the block may now be removed (see figure 7-18).

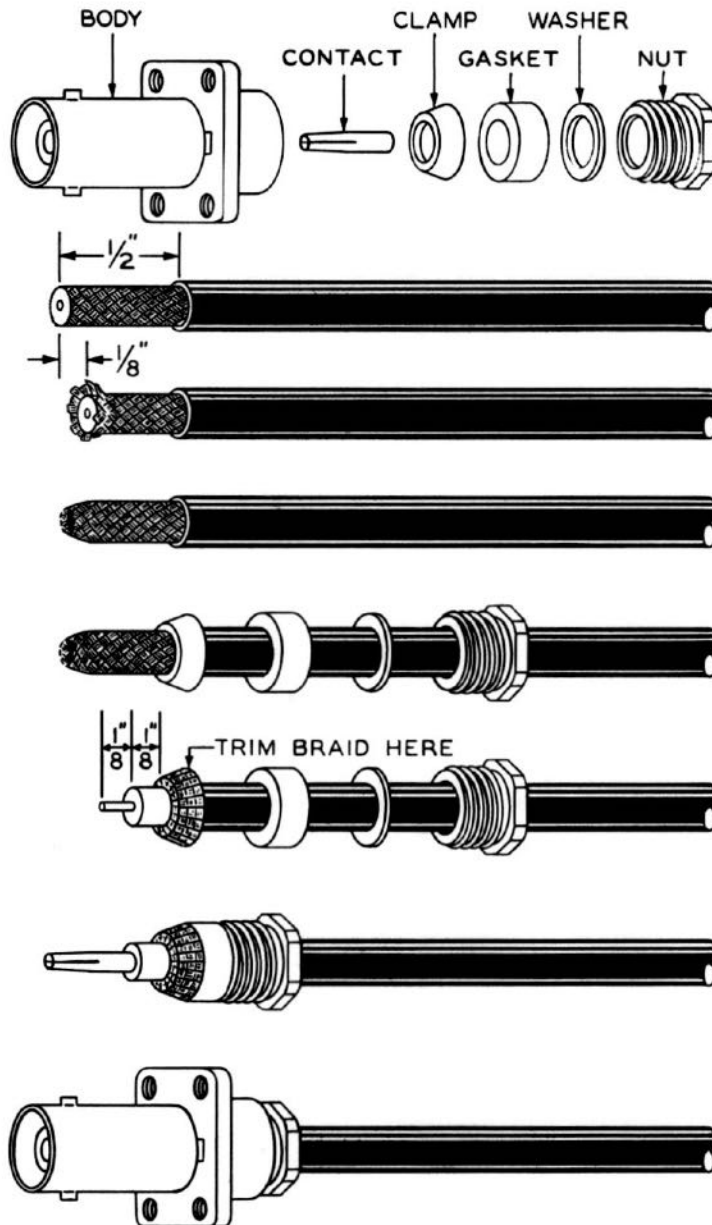
(1) Unsolder the defective resistor being careful not to damage the spacer washer.

(2) Slip the spacer washer over the body of the new resistor, then resolder leads. Do not use excessive

heat when making these soldered connections.

(3) Allow a few minutes for the resistor to attain room temperature, then measure the resistance between either connector and ground; this should be 50 ohms $\pm 2\%$. Resistors that are less than allowable value may be adjusted by scraping the resistive element with a file or hand grinder; the resistor should then be coated completely with fungicidal varnish. Resistors above allowable value should be replaced.

(4) Reassemble block and restore all screws.



Step 1. Cut off jacket $\frac{1}{2}$ " from end, being careful not to nick braid.

Step 2. Push braid back sufficient to permit cutting $\frac{1}{8}$ " off inner dielectric and center conductor.

Step 3. Pull braid over end of cable and taper to smaller diameter.

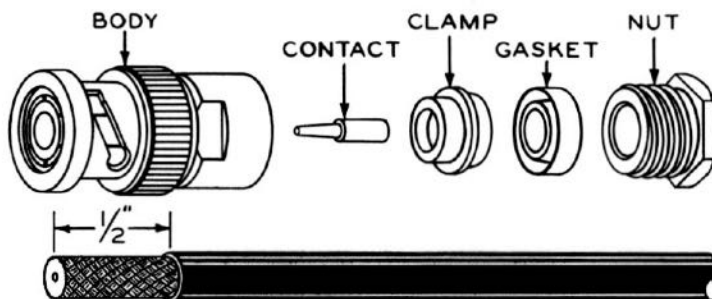
Step 4. Slide nut, washer and gasket over outer jacket of cable. Slide clamp over braid until inner shoulder of clamp seats squarely against jacket of cable.

Step 5. Comb out braid, fold back over clamp and trim as shown. Cut off dielectric at $\frac{1}{8}$ " from braid, being careful not to nick inner conductor. Then cut off inner conductor $\frac{1}{8}$ " from end of dielectric.

Step 6. Tin end of cable inner conductor. Tin inner hole of contact. Solder contact to cable. Use no more heat than necessary to avoid swelling of the dielectric. Remove any excess solder.

Step 7. Push cable into body until clamp is seated. Hold body and cable rigidly and screw nut in place until seated snugly.
Method for assembling Type UG-88C/U

METHOD OF ASSEMBLING TYPE UG-88C/U CONNECTOR AND TYPE RG-58C/U CABLE



Method of Assembling Type UG-291/U Connector and Type RG-58C/U Cable

Use same procedure as described in Steps 1 through 7 above.

Figure 7-19. Methods of Assembling Cord and Cable

TABLE 7-3. TUBE OPERATING VOLTAGES AND CURRENTS

| TUBE TYPE | FUNCTION | PLATE E | SCREEN E | SUP-PRESSOR E | CATHODE E | GRID E | HEATER E | |
|-----------|-------------------|------------------|----------|---------------|-----------|--------|----------|-----|
| | | | | | | | DC | AC |
| 6005 | Voltage Regulator | 390 | 390 | 160 | 160 | 140 | 160 | |
| 6005 | Modulator | 150 | 160 | 10 | 10 | 0 | | 6.3 |
| 6005 | AF Oscillator | 250 | 160 | 11 | 11 | 0 | | 6.3 |
| 6AU6WA | Voltage Regulator | 140 | 100 | 55 | 55 | 50 | | 6.3 |
| 6AU6WA | AF Oscillator | 75 | 60 | 1.4 | 1.4 | 0 | | 6.3 |
| 6F4 | RF Oscillator | 145 | | | 0* | | | 6.3 |
| 6X4WA | Rectifier | 315 (AC) | | | 390 | | 160 | |
| 5814 | VTVM | -55 | | | 0 | -55 | | 6.3 |
| 5814 | Modulator | 75 | | | 35 | 20 | | 6.3 |
| 5814 | Meter Rectifier | 0 | | | 3.2 (AC) | -3.5 | | 6.3 |
| 5751 | Meter Amplifier | (1) 20 (6) 60 | | | 0 | 0 | | 6.3 |

NOTE: The measurement of operating currents is not recommended. Insertion of current meters in plate and screen circuits may so upset the generator circuits as to make meter readings meaningless.

*Not oscillating.

TABLE 7-4. TUBE CHARACTERISTICS

| TUBE TYPE | FILA-MENT VOLT-AGE | FILA-MENT CUR-RENT | PLATE VOLT-AGE | GRID BIAS | SCREEN VOLT-AGE | PLATE CUR-RENT | SCREEN CUR-RENT | AC PLATE RESIST-ANCE | VOLT-AGE AMPLIFI-CATION FACTOR | TRANSCON-DUCTANCE (MICROMHOS) | | EMISSION | |
|-----------|--------------------|--------------------|----------------|-----------|-----------------|----------------|-----------------|----------------------|--------------------------------|-------------------------------|----------|----------|-----------|
| | | | | | | | | | | NOR-MAL | MINI-MUM | IS | TEST VOLT |
| | V | A | V | V | V | MA | MA | OHMS | MU | | | MA | |
| 5751 | 6.3° | .35° | 250 | -3 | | 1.0 | | 58000 | 70 | 1200 | 900 | | |
| 5814 | 6.3° | .35° | 250 | -8.5 | | 10.5 | | 6250 | 19.5 | 2200 | 1750 | | |
| 6AU6WA | 6.3 | .30 | 250 | -1 | 150 | 10.8 | 4.3 | 2 Meg | | 5200 | 4150 | | |
| 6F4 | 6.3 | .225 | 150 | | | 13 | | 2900 | 17 | 5800 | | 40 | 10 |
| 6X4WA | 6.3 | .60 | 400AC | | | 70 | | | | | | 140 | 50 |
| 6005 | 6.3 | .45 | 250 | -12.5 | 250 | 45 | 4.5 | 52000 | | 4100 | 3000 | | |

*For parallel filaments.

TABLE 7-5. WINDING DATA

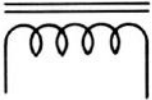
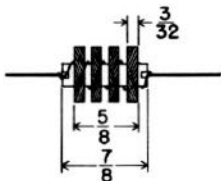
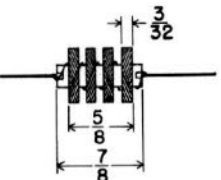
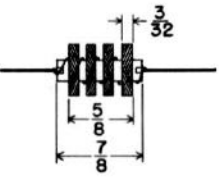

| DESIG- NATION SYMBOL | MEAS. CORP. PART No. | DIAGRAM | WINDING | WIRE SIZE | URNS | D.C. RE- SISTANCE IN OHMS | REMARKS |
|----------------------------|----------------------------|---|--------------------|--------------------------------------|------|---------------------------------|--|
| L-101 | H-3662 |  | Single | | | 450 max. | Inductance: 15 Hy \pm 20% @ 30 ma., 1000 cps per Spec. MIL-T-27. |
| L-102 | H-4692 |  | 4 pie universal | #38SSE | 800 | 50 approx. | Inductance: 7 mh \pm 20% @ 1000 cps. Wound on powdered iron core M.C. Part H-3536. Impregnate with wax, Zophar Mills #1340TP. |
| L-103 | H-4693 |  | 4 pie universal | #38SSE | 1000 | 66 approx. | Inductance: 10 mh \pm 20% @ 1000 cps. Wound on powdered iron core M.C. Part H-3536. Impregnate with wax. |
| L-104 | H-4691 |  | 4 pie universal | #38SSE | 600 | 34 approx. | Inductance: 4 mh \pm 20% @ 1000 cps. Wound on powdered iron core M.C. Part H-3536. Impregnate with wax. |
| L-105 | H-3518 |  | 1 pie universal | #36 single Vitrotex covered | 45 | 2 \pm 20% | Inductance: 18 microhenries \pm 20% @ 1000 cps. Wound on bakelite coil form. |

TABLE 7-5. WINDING DATA—Continued

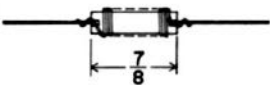
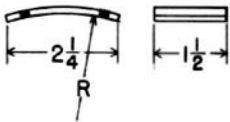
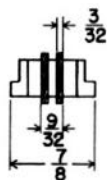
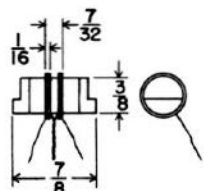
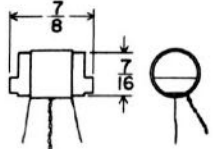
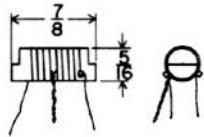
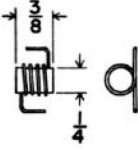
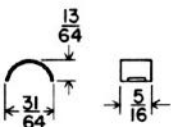
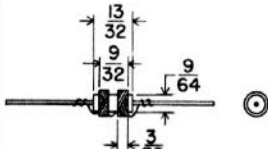
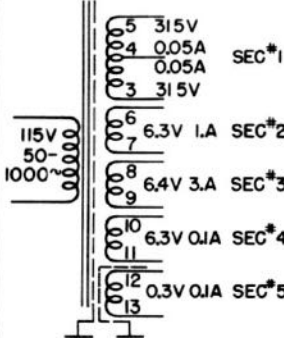
| DESIG- NATION SYMBOL | MEAS. CORP. PART No. | DIAGRAM | WINDING | WIRE SIZE | TURNS | D.C. RE- SISTANCE IN OHMS | REMARKS |
|----------------------------|----------------------------|---|--|--------------------------------------|---------------|---------------------------------|--|
| L-111 | H-4694 |  | single layer, close | #26E | 40 | | Inductance: 15 microhenries \pm 20% @ 1000 cps. Wound on powdered iron core. M.C. Part H-3536. Impregnate with wax. |
| L-113 | H-3588 |  | single layer, close | #22 double nylon covered | 55 | | Inductance: 14 microhenries \pm 50% @ 1000 cps. Wound on rectangular polystyrene coil form 2 1/4" x 1 1/2" x 3/32". |
| L-116 | H-3465 |  | 2 pie universal | #32 single Vitrotex covered | 20 per pie | 3.2 \pm 20% | Inductance: 53 microhenries @ 1000 cps. Pies wound in opposite directions. Wound on powdered iron core, M.C. Part H-3497. Q = 70 \pm 20%; C = 400 mmf @ 1080 KC \pm 2%. Impregnate with wax. |
| L-117 | H-3466 |  | 2 pie universal | #38 single Vitrotex covered | 9 per pie | 1.2 \pm 20% | Inductance: 11 microhenries @ 1000 cps. Pies wound in opposite directions. Wound on powdered iron core, M.C. Part H-3497 covered with 4 turns Scotch tape. Q = 65 \pm 20%; C = 400 mmf @ 2.4 Mc \pm 2%. Impregnate with wax. |
| L-118 | H-3467 |  | single layer spaced 52 turns per inch. Center tapped | #30 Formex enamel covered | 21 | | Inductance: 3.3 microhenries @ 1000 cps. Wound on powdered iron core, M.C. Part H-3468. Q = 80 \pm 20%; C = 400 mmf @ 4.35 Mc \pm 2%. Coat with cement, Amphenol #912. |

TABLE 7-5. WINDING DATA—Continued

| DESIG-NATION SYMBOL | MEAS. CORP. PART No. | DIAGRAM | WINDING | WIRE SIZE | TURNS | D.C. RE-SISTANCE IN OHMS | REMARKS |
|---------------------|----------------------|---|--|--------------------|---|--------------------------|---|
| L-119 | H-3599 |  | single layer spaced by #24E covered wire | #28 enamel covered | 9 $\frac{2}{3}$ tapped at 4 $\frac{2}{3}$ turns | | Inductance: 0.6 microhenries @ 1000 cps. Wound on Micalox coil form, M.C. Part H-3598. Impregnate with wax. |
| L-120 | H-3601 |  | single layer, space wound | #18 fine silver | 4 | | Polystyrene coil support $\frac{3}{8}$ " x $\frac{1}{4}$ " x $\frac{1}{32}$ ". |
| L-121 | H-3602 |  | Metal strip 0.020" thick coin silver | | $\frac{1}{2}$ | | |
| L-132 | H-4344 |  | 2 pie universal | #38SSE | 70 per pie | 5 p/m 20% | Inductance: 50 microhenries \pm 20% @ 1000 cps. Wound on resistor RC10BF106K. Impregnate with wax. |
| T-101 | H-4699 |  | | | | | Constructed per Spec. MIL-T-27. Grounded electrostatic shield between primary and all other windings. Grounded electrostatic shield between secondary #5 and all other windings. Voltages shall be in phase at terminals 11 and 13 when terminals 10 and 12 are connected together. |

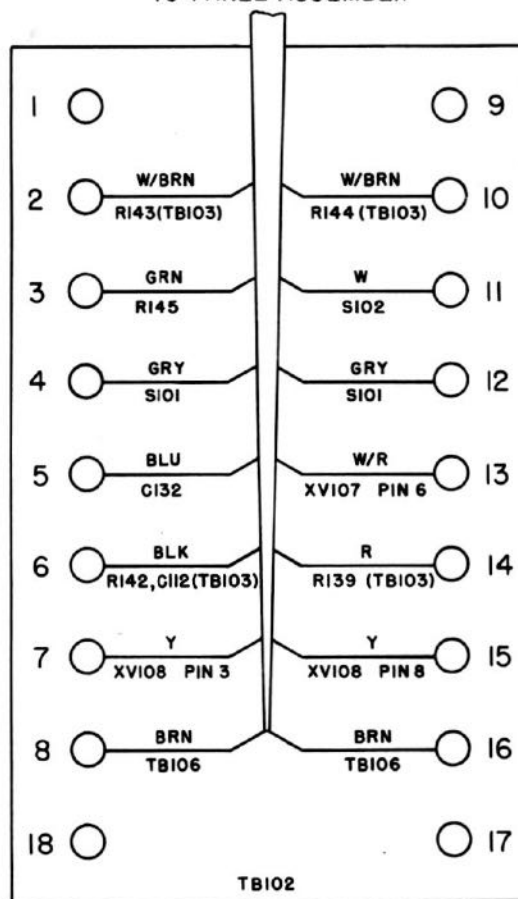
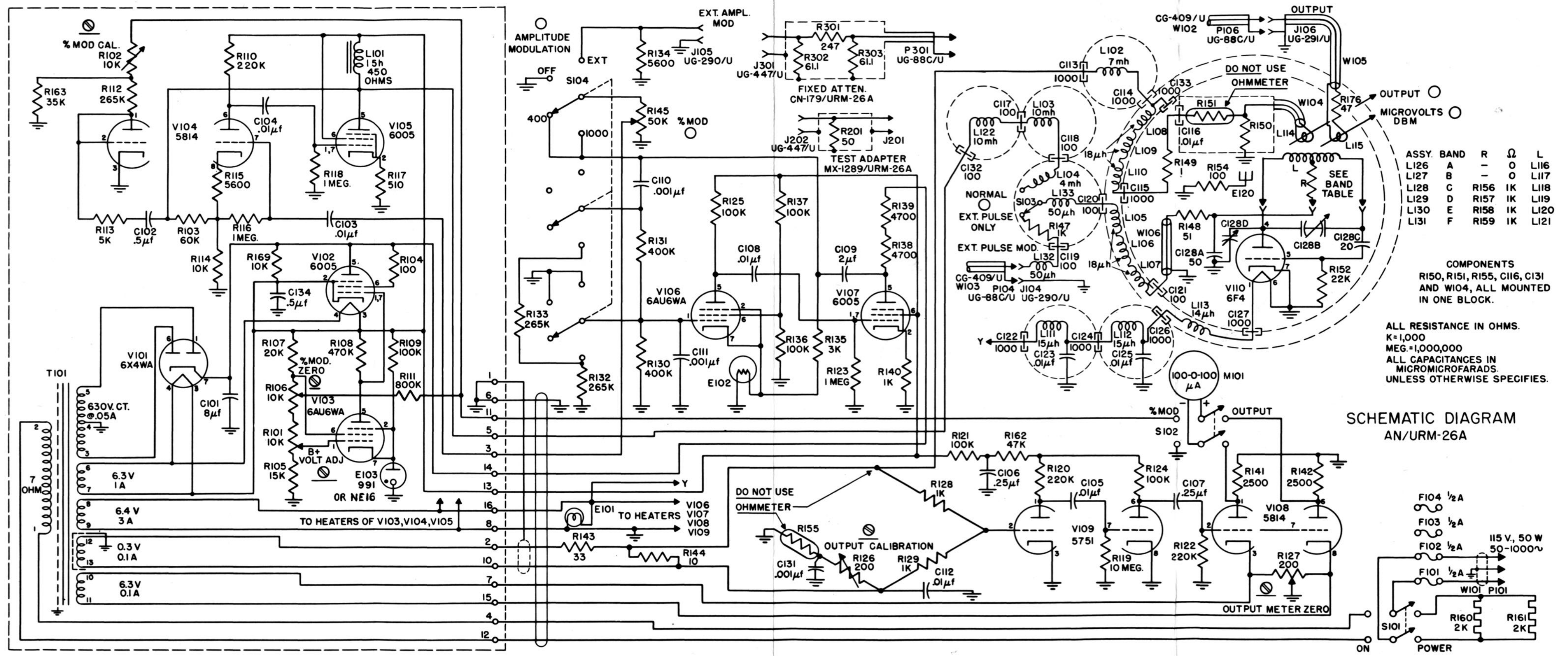


Figure 7-20. RF Signal Generator SG-45A/URM-26, Wiring Diagram, Interconnection, Power Supply to Panel Assembly



SCHEMATIC DIAGRAM
AN/URM-26A

Figure 7-21. RF Signal Generator Set AN/URM-26A, Schematic Diagram

ORIGINAL

SECTION 8 PARTS LIST

Table 8-1. MAINTENANCE PARTS LIST.

a. This table lists the various components used in RF Signal Generator Set AN/URM-26A. It provides a short description of each part, its function in the equipment, and the manufacturer's name (by abbreviation).

b. Notes indicated in column 2 of this list are as follows:

1. For reference only.
2. This unit should not be replaced unless repair is beyond the capacity of the using activity. If replacement is required, the item must be turned in to the activity from which the replacement is received.
3. Low Failure item. If required, requisition from ESO referencing NAVShips 900, 180A.
4. Shop manufacture.
5. Assemble from component parts.

Abbreviations refer to Manufacturers listed in Table 8-4.

Table 8-2. STOCK NUMBER IDENTIFICATION.

a. This table lists the reference designation of each component with its associated Navy Stock Number.

Table 8-3. STOCK NUMBER CROSS REFERENCE.

a. This table lists Navy Stock Number in alpha-numerical order and the corresponding reference symbol.

Table 8-4. LIST OF MANUFACTURERS.

a. This table lists the name and address of manufacturers and the abbreviation used to identify the manufacturer in Table 8-1.

TABLE 8-1. MAINTENANCE PARTS LIST

| REF. DESIG. | NOTES | NAME AND DESCRIPTION | LOCATING FUNCTION |
|---------------------------|-------|--|---|
| Series 101 thru 199 | | <p>GENERATOR SET, RF SIGNAL: range 3 to 405 megacycles; 6 bands; frequency calibration accuracy p/m 0.5%; calibrated output 0.1 to 50,000 microvolts, accuracy p/m 10% between 3 and 100 megacycles, p/m 20% between 100 and 405 megacycles; output impedance 50 ohms; AM modulation, 400 and 1000 cycle internal; provision for external modulation, sine-wave and pulse; modulation controllable from 0 to 50%; operates from single phase, 115 volt, 50-1000 cycle power source; overall dim. 15$\frac{1}{8}$" w x 11$\frac{1}{2}$" h x 10$\frac{3}{4}$" d; per Spec MIL-S-15463 (SHIPS) dated 15 July 1950; Major components consist of:</p> <p>1 RF Signal Generator SG-45A/URM-26, Measurements Corp. Part No. H-3450.</p> <p>1 Fixed Attenuator CN-179/URM-26A, Measurements Corp. Part No. HA-3423.</p> <p>1 Test Adapter MX-1289/URM-26A, Measurements Corp. Part No. HA-3425.</p> <p>2 Cords CG-409/U (4'-0") Measurements Corp. Part No. H-3422.</p> <p>SNSN F16-Q-123656-100.</p> | |
| C-101 | | CAPACITOR, fixed: paper dielectric; 8 mfd + 40% -50%; 600 vdcw; hermetically sealed metal case; 3 $\frac{3}{4}$ " lg. x 1 $\frac{1}{4}$ " w. x 3 $\frac{7}{8}$ " h.; two lug terminals on top; impregnated and filled; no internal ground; mtg brackets not supplied (see symbol H-103); Spec JAN-C-25. Type CP70B1DF805X. | Power Supply Filter Cathode V-101 |
| C-102 | | CAPACITOR, fixed: paper dielectric; 500,000 mmf p/m 10%; 600 vdcw; hermetically sealed metal case; 2 $\frac{1}{2}$ " lg. x 1" w. x 1" h.; two lug terminals on side; impregnated and filled; no internal ground; two mtg feet with 3/16" dia. hole in each, spaced 2 $\frac{1}{8}$ " C to C, Spec. JAN-C-25. Type CP53B1EF504K. | VTVM Coupling V-104 term 2 |
| C-103 | | CAPACITOR, fixed: mica dielectric; 10,000 mmf p/m 10%; 300 vdcw; characteristic letter B; low loss molded phenolic case; max. dim. 1-1/32" lg. x 41/64" w. x 11/32" deep; two axial wire leads, one each end, terminal mounted; Spec. JAN-C-5. Type CM40B103K. | Grid Coupling V-104 term 7 |
| C-104 | | Same as C-103. | Grid Coupling V-105 terms 1 and 7 |
| C-105 | | CAPACITOR, fixed: mica dielectric; 10,000 mmf p/m 20%; 300 vdcw; characteristic letter B; low loss molded phenolic case; 53/64" lg. x 53/64" w. x 11/32" d.; two wire leads, one each end; terminal mounted; Spec. JAN-C-5. Type CM35B103M. | Grid Coupling V-109 term 7 |
| C-106 | | CAPACITOR, fixed: paper dielectric; 250,000 mmf p/m 10%; 600 vdcw; hermetically sealed metal case; 2 $\frac{1}{2}$ " lg. x 1" w. x 3/4" h.; two lug terminals on side; impregnated and filled; no internal ground; two mtg feet with 3/16" dia. hole in each, spaced 2 $\frac{1}{8}$ " C to C; Spec. JAN-C-25. Type CP53B1EF254K. | Plate Filter V-109 |
| C-107 | | Same as C-106. | Grid Coupling V-108 term 2 |
| C-108 | | Same as C-105. | Grid Coupling V-107 terms 1 and 7 |
| C-109 | | CAPACITOR, fixed: paper dielectric; 2.0 mfd p/m 10%; 600 vdcw; hermetically sealed nonmagnetic case; 2" lg. x 2" w. x 1 $\frac{1}{8}$ " h.; two lug type terminals on side; impregnated and filled; no internal ground; two mtg feet with 3/16" dia. hole in each spaced 2 $\frac{3}{8}$ " C to C; Spec. JAN-C-25 Type CP53B1DF205K. (Standard part modified by change of characteristic from D to E, to Type CP53B1EF205K, SNSN N16-C-49127-3878.) | AF Feedback V-107 term 5 |

MAINTENANCE PARTS LIST—Continued

| REF. DESIG. | NOTES | NAME AND DESCRIPTION | LOCATING FUNCTION |
|-------------|-------|--|--|
| C-110 | | CAPACITOR, fixed: mica dielectric; 1000 mmf p/m 2%; 500 vdcw; characteristic letter D; low loss molded phenolic case; 53/64" lg. x 53/64" w. x 9/32" d.; two wire leads, one each end; terminal mounted; Spec. JAN-C-5 Type CM30D102G. | AF Tuning V-107 to V-106 |
| C-111 | | Same as C-110. | AF Tuning V-106 Grid 1 |
| C-112 | (CL) | CAPACITOR, fixed: ceramic dielectric; 10,000 mmf min.; 500 vdcw; variable temp coef; insulated; 1-5/32" lg. max. x 9/32" dia max; two radial wire terminals; terminal mounted; Centralab Part No. DA-502-006; Measurements Corp. Part No. H-3492. | Bolometer Bridge balancing capacitor |
| C-113 | (CL) | CAPACITOR, fixed: ceramic dielectric; 1000 mmf GMV; 500 vdcw; metal case; 1/2" hex x 5/16" lg.; center solder terminal and lug, case is ground terminal; mounts in single hole by 7/16"-28 hex nut; Measurements Corp. Part No. H-4696. Centralab Part No. DA-902-000. | RF filter measuring arm, bolometer bridge |
| C-114 | | Same as C-113. | RF filter measuring arm, bolometer bridge |
| C-115 | | Same as C-113. | RF filter measuring arm, bolometer bridge |
| C-116 | (MC) | CAPACITOR, fixed: ceramic dielectric; 10,000 mmf + 100% -0%; 500 vdcw; variable temp coef; uninsulated 1 1/4" lg. x 3/8" dia; one solder terminal, one sleeve terminal; sleeve mounted on 0.370" dia; Measurements Corp. Part No. H-3511. | Bypass Bolometer R-151 |
| C-117 | (CL) | CAPACITOR, fixed: ceramic dielectric; 100 mmf p/m 20%; 500 vdcw; metal case; 1/2" hex. x 5/16" lg.; center solder terminal and lug, case is ground terminal; mounts in single hole by 7/16-28 hex nut; Centralab Part No. DA-902-000, Measurements Corp. Part No. H-4695. | RF filter B + input to V-110 |
| C-118 | | Same as C-117. | RF filter B + input to V-110 |
| C-119 | | Same as C-117. | RF filter Pulse input to V-110 |
| C-120 | | Same as C-117. | RF filter Plate supply V-110 |
| C-121 | | Same as C-117. | RF filter Plate supply V-110 |
| C-122 | | Same as C-113. | RF filter heater V-110 |
| C-123 | | CAPACITOR, fixed: ceramic dielectric; 10,000 mmf +100% -20%; 500 vdcw; characteristic Y; overall dim. 13/16" dia. max. x 13/64" thk max; two parallel wire leads; per Spec MIL-C-11015 Type CK63Y103Z. | RF filter heater V-110 |
| C-124 | | Same as C-113. | RF filter heater V-110 |
| C-125 | | Same as C-123. | RF filter heater V-110 |
| C-126 | | Same as C-113. | RF filter heater V-110 |
| C-127 | | Same as C-113. | RF filter heater V-110 |
| C-128 | (MC) | CAPACITOR ASSY, variable: one fixed, mica dielectric, 50 mmf (A); two section variable, air-dielectric, 10-110 mmf per section (B); one fixed, mica dielectric, 20 mmf (C); one adjustable, air-dielectric, 1 mmf (D); 2-11/16" lg. x 2 1/2" w. x 3-9/64" h.; shaft extends 1 1/2"; two studs #4-40 x 5/16" at 17/64" x 1-41/64"; four mtg holes tapped 4-40 at 63/64" x 63/64"; Measurements Corp. Part No. H-4690. | See C-128A, B, C, D following |

MAINTENANCE PARTS LIST—Continued

| REF. DESIG. | NOTES | NAME AND DESCRIPTION | LOCATING FUNCTION |
|-------------|-------|--|--------------------------------------|
| C-128A | 1 | p/o C-128. | RF filter, plate supply V-110 |
| C-128B | 1 | p/o C-128. | Osc. tuning |
| C-128C | 1 | p/o C-128. | Grid coupling V-110 |
| C-128D | 1 | p/o C-128. | Trimmer C-128B |
| C-129 | | Not used. | |
| C-130 | | Not used. | |
| C-131 | (MC) | CAPACITOR, fixed: ceramic dielectric; 1000 mmf +100% -0%; 500 vdcw; variable temp coef; uninsulated; 0.370" dia. x 7/16" lg; one solder terminal, body is other terminal; sleeve mounted on 0.370" dia; Measurements Corp. Part H-3509. | By-pass bolometer R-155 |
| C-132 | | Same as C-117. | RF filter B + input to V-110 |
| C-133 | | Same as C-113. | Bolometer filter by-pass |
| C-134 | | Same as C-102. | Cathode by-pass V-102 |
| E-101 | (GE) | LAMP, INCANDESCENT: 6-8V, 0.25 amp; min bay base; bulb T-3¼ frosted; 1⅞" high max; General Electric Co. lamp No. 44F; Measurements Corp. Part No. H-3654. | Pilot light |
| E-102 | (GE) | LAMP, INCANDESCENT: 120V, 3 watts; double contact bayonet candelabra base; bulb S6 clear; 1-13/16" high o/a; General Electric Co. lamp No. 3WS6; Measurements Corp. Part No. H-4687. | AF Osc. control, V-106 cathode |
| E-103 | (GE) | LAMP, GLOW: ¼ watt; 85V striking voltage; double contact bayonet candelabra base; bulb T4½ clear; 1-9/16" high max; GE #NE16; Measurements Corp. No. H-3656. | Voltage Stabilizer V-103 cathode |
| E-104 | 3 | PLUNGER: comprises flatted cylinder, gear rack; pin, and set bolt; 3-29/64" lg. x ⅝" dia.; running fit in attenuator tube; Measurements Corp. Part No. H-3374. | Carries MICROVOLTS output loop L-115 |
| E-105 | | Not used. | |
| E-106 | 3 | KNOB: bar w/pointer; black phenolic resin; for ¼" dia. round shaft; shaft hole ½" deep; one #8-32 Allen head set screw; brass insert, counterbored ⅝" dia. x 3/32" deep, radial white line; 1¼" lg. x ¾" w. x ⅝" h.; H. Davies Part No. 2300A w/2 Allen head set screws; Measurements Corp. Part No. H-3679. | Modulation selector |
| E-107 | 3 | KNOB: bar; aluminum, black finish; for 5/16" dia. round shaft; shaft hole 7/16" deep; two #10-32 Allen head set screws 180 deg apart; no marking; 2⅛" lg. x ½" w. x ¾" h.; Measurements Corp. Part No. H-3680. | Range selector |
| E-108 | (DM) | KNOB: round, fluted; black phenolic resin; for ¼" dia. round shaft; shaft hole 19/32" deep; two Allen head #8-32 set screws 90 deg. apart; brass insert; no marking; 1⅜" dia. x 11/16" h.; H. Davies Part No. A4101 w/2 Allen head set screws; Measurements Corp. Part No. H-3683. | % MOD control |
| EV-101 | | SHIELD, ELECTRON TUBE: brass, nickel plated; cylindrical; bayonet type mtg; 2¼" lg. x 0.930" dia.; Spec. JAN-S-28A Type TS102U03. | Shields V-101 |
| EV-102 | | Same as EV-101. | Shields V-102 |
| EV-103 | | SHIELD, ELECTRON TUBE; brass, nickel plated; cylindrical, open top, bayonet type mtg; 1¾" lg. x 0.930" dia. Spec. JAN-S-28A Type TS102U02. | Shields V-103 |
| EV-104 | | SHIELD, ELECTRON TUBE; brass, nickel plated; cylindrical, open top; bayonet lock mounted; 1-15/16" lg. x 1.065" dia.; Spec. JAN-S-28A Type TS103U02. | Shields V-104 |

MAINTENANCE PARTS LIST—Continued

| REF. DESIG. | NOTES | NAME AND DESCRIPTION | LOCATING FUNCTION |
|-------------|-------|---|---|
| EV-105 | | Same as EV-101. | Shields V-105 |
| EV-106 | | Same as EV-103. | Shields V-106 |
| EV-107 | | Same as EV-101. | Shields V-107 |
| EV-108 | | Same as EV-104. | Shields V-108 |
| EV-109 | | Same as EV-104. | Shields V-109 |
| F-101 | | FUSE, cartridge: 1/2 amp; 250V; delayed action; rated continuous at 135%; opens in 6 seconds at 300%; ferrule terminals 1/4" lg. x 1/4" dia.; glass body; one time; non-indicating; 1 1/4" lg. x 1/4" dia.; Spec MIL-F-15160 Type F02GR500B. | Line fuse |
| F-102 | | Same as F-101. | Line fuse |
| F-103 | | Same as F-101. | Spare |
| F-104 | | Same as F-101. | Spare |
| H-101 | 4 | BOLT, (CAPTIVE SCREW): brass, black nickel finish; slotted head, 3/8" high x 3/8" dia.; reduced shank 1/8" dia. x 7/16" lg.; thread #8-32 NC2 x 3/16" lg.; furnished with lockwasher and plain round nut; Measurements Corp. Part No. H-3957. | Hold panel |
| H-102 | 4 | BUTTON, plug: brass, silver plated; for 3/8" dia. hole; 17/32" dia. x 7/32" lg.; Measurements Corp. Part No. H-3933. | Plug access holes in shields |
| H-103 | | CLAMP, capacitor: steel; painted; hook type; 3-11/16" h. x 29/32" w. x 0.045" thick min; single spade lug #10-32 x 5/8" lg. thread; Spec JAN-C-25 Type CP07SC2. | Hold C-101 |
| H-104 | 3 | PANEL, MOUNTING: gray finish; 9-7/32" lg. x 5-13/16" w. x 11/16" d.; four mtg holes; 3/16" dia. at 5 1/8" x 8-9/16" centers; engraved to show fuse ratings and spare fuseholders; includes rubber cushions; Measurements Corp. No. H-3868-C. | Encloses tuning dial and drive |
| H-105 | 3 | FASTENER, latch: steel, gray finish; 2-1/16" lg. x 1-7/16" w. x 9/16" h.; two mtg holes 0.140" dia on 7/16" centers in latch, two mtg holes 0.154" dia. on 17/32" centers in catch; per Signal Corps Dwgs., Catch (small) Dwg. SC-D-20648, Catch Top Dwg SC-D-20650-27. Measurements Corp. Part No. H-3927. | Holds outer case cover |
| H-106 | 3 | PLATE, INDEX: transparent acrylic resin plate with brass support; 3-3/16" lg. x 2-7/16" w. 5/64" thick; single line engraved on rear face; line filled black; two mtg. holes 3/16" dia. on 2-11/16" centers; Measurements Corp. Part No. H-3872. | Frequency scale reference |
| H-107 | 3 | PLATE, INDEX: black phenolic sheet; 3/4" lg. x 1/4" radial width; 1 3/8" radius of inner edge; 1/8" thick; single radial line engraved on front face and filled white; two mtg. holes 1/16" dia. on 7/16" centers. Measurements Corp. Part No. H-3867. | Tuning control dial reference |
| H-108 | (MC) | DIAL SUBASSEMBLY: rotatable, black phenolic rim molded on metal disc; 3 3/8" OD x 9/16" lg.; mounts on 3/8" dia. shaft and fastens with two #6-32 set screws; includes hub, fixed stop; adjustable wedge stop and two screws, nuts and washers for attaching index plate H-127. Measurements Corp. Part No. H-4870. | Controls monitor loop and carries index H-127 |
| H-109 | 3 | BUMPER, vibration: rubber cushion with nickel plated brass stud; 7/8" dia. x 1/2" high excluding stud; #10-32 stud extends 5/16"; Measurements Corp. Part No. H-3846. | Outer case rest |
| H-110 | 3 | HANDLE: hinged; metal, with plastic coated grip; 5 1/4" lg. x 2 5/8" h. x 1 1/4" wide o/a including mounting plate; Measurements Corp. Part No. H-4686. | Case carrying |
| H-111 | 3 | HANDLE: panel pull; 3/8" dia. aluminum rod, gray enamel finish; 9-17/32" lg. x 2 3/8" w. x 3/8" thick; one piece; one mtg. hole each end tapped #8-32 x 1/4" deep on 9-5/32" centers; furnished with mtg. bolts and lockwashers; Measurements Corp. Part No. H-3965. | Panel pull |

MAINTENANCE PARTS LIST—Continued

| REF. DESIG. | NOTES | NAME AND DESCRIPTION | LOCATING FUNCTION |
|-------------|-------|--|---------------------------------|
| H-112 | | Not used. | |
| H-113 | 4 | GASKET: rubber; irregular shape; one hole through cross section; 49 $\frac{5}{8}$ " lg. x 17/32" w. x 1/4" thick; Measurements Corp. Part No. H-3426. | Seals case cover |
| H-114 | | Not used. | |
| H-115 | 3 | SPRING: formed flat type; 0.010" thick coin silver, spring temper; 2" lg. x 5/8" w. x 7/8" h.; two mtg. holes 0.144" dia. on 1/2" centers; two dimples; Measurements Corp. Part No. H-3934. | Grounds coil mounting to shield |
| H-116 | 3 | NUT, plain, round; brass, silver plated; flatted for wrench, 1" across flats; tapped 1/2"-27 thread; 1 1/4" OD x 3/16" thick; Measurements Corp. Part No. H-3932. | Holds coil mounting |
| H-117 | 3 | FASTENER, latch; steel, nickel plated; 2 1/4" lg. x 11/16" w. x 5/16" h.; two mtg. holes 0.128" dia. on 1/4" centers in latch and in catch; Measurements Corp. Part No. H-3936. | Holds oscillator shield cover |
| H-118 | 4 | WASHER, flat: round; brass; nickel plated; 0.128" dia. center hole, 1/4" OD, 0.010" thick; Measurements Corp. Part No. H-3903. | Retains roller O-111 |
| H-119 | 4 | WASHER, flat: round; brass; nickel plated; 0.128" dia. center hole, 3/8" OD, 0.010" thick; Measurements Corp. Part No. H-3907. | Retains roller O-116 |
| H-120 | | WASHER, flat: round; brass; nickel plate finish; 9/32" dia. center hole ctbd 5/8" dia. 1/32" deep; 15/16" OD, 1/16" thk.; Measurements Corp. Part No. H-4949. | Spaces MICROVOLTS dial |
| H-121 | 4 | WASHER, spring: round phosphor bronze; no finish; 13/32" dia. center hole, 1" OD, 0.015" thick; formed to 1/8" high; Measurements Corp. Part No. H-3894-1. | Friction for dial sub-assembly |
| H-122 | (AM) | WRENCH: hex key type; .050 across flats; long arm 1 3/4" lg., short arm 9/16" lg.; alloy steel; 90° offset; no handle; for #4 Allen setscrew; Allen Mfg. Co. Part No. 4 short arm hex key. | Setscrew wrench |
| H-123 | (AM) | WRENCH: hex key type; 1/16" across flats; long arm 1 3/4" lg., short arm 9/16" lg.; alloy steel; 90° offset; no handle; for #6 Allen setscrew; Allen Mfg. Co. Part No. 6 short arm hex key. | Setscrew wrench |
| H-124 | (AM) | WRENCH: hex key type; 5/64" across flats; long arm 1 7/8" lg., short arm 39/64" lg.; alloy steel; 90° offset; no handle; for #8 Allen setscrew; Allen Mfg. Co. Part No. 8 short arm hex key. | Setscrew wrench |
| H-125 | (AM) | WRENCH: hex key type; 3/32" across flats; long arm 2" lg., short arm 21/32" lg.; alloy steel; 90° offset; no handle; for #10 Allen setscrew; Allen Mfg. Co. Part No. 10 short arm hex key. | Setscrew wrench |
| H-126 | (HMC) | CLAMP, CABLE: black plastic; two pieces; 7/16" lg. x 9/16" dia.; to hold RG-108/U cable; mounts in single hole 1/2" dia.; Heyman Mfg. Co. Part No. SR-5P; Measurements Corp. Part No. H-4852. | Clamps cable W-101 |
| H-127 | 3 | PLATE, INDEX: clear plastic; red line; 1-1/16" lg. x 3/4" w. x 1/16" thick; two mtg. holes 1/8" dia. on 13/16" centers; mounts on dial sub-assembly H-108; Measurements Corp. Part No. H-3975. | Output voltage index |
| I-101 | 5 | LIGHT, INDICATOR: with lens; for miniature bayonet base lamp; 1 1/8" lg. x 7/8" w. x 1-3/64" h. max.; mounts in single hole 11/16" dia.; red convex lens, smooth face, frosted back; lamp replaceable from front; Spec. MIL-L-3661 Type LH50BR2. | Pilot light |
| I-101A | | LIGHT, INDICATOR: lampholder only; for miniature bayonet base lamp; Spec. MIL-L-3661 Type LH50; p/o I-101. | |
| I-101B | | LENS, INDICATOR LIGHT: convex, red smooth front, frosted back; 1/2" dia.; Spec. MIL-L-3661 Type BR2 to fit Type LH50 indicator light; p/o I-101. | |
| I-102 | (MC) | DIAL, control: disc type; 100 equal divisions over 360 degrees; for 1/4" dia. round shaft; shaft hole 3/4" deep; o/a dim. 1" h. x 2 3/4" dia.; two #10-32 set screws at 90 deg. apart; dial not illuminated; Measurements Corp. Part No. H-3681. | Main tuning drive |

MAINTENANCE PARTS LIST—Continued

| REF. DESIG. | NOTES | NAME AND DESCRIPTION | LOCATING FUNCTION |
|-------------|-------|--|---|
| I-103 | (MC) | DIAL, CONTROL: disc type; MICROVOLTS, 50K to .1 clockwise, logarithmic graduation, 92 divisions marked at 50K, 30K, 10K, 3K, 1K, 300, 100, 30, 10, 3, 1, .3, .1; DBM, -14 to -128 clockwise, 57 divisions marked at -20, -40, -60, -80, -100, -120; for 1/4" dia. round shaft; shaft hole 9/16" deep; stop pin on back; o/a dim. 15/16" h. x 2 3/4" dia.; two #10-32 set screws; dial not illuminated; Measurements Corp. Part No. H-4879. | Output voltage level control |
| I-104 | (MC) | DIAL, scale, uncalibrated main tuning dial; round; 5 1/2" OD x 1/2" ID x 5/16" lg. o/a; three curved mtg. slots, to clear #3 bolts, equally spaced at 0.352" radius; brass; white finish on front; knurled teeth on periphery; stop pin on back. Measurements Corp. Part No. H-3854. | Frequency indicator |
| I-105 | (MC) | MASK, dial: for disclosing and identifying each of six frequency scales, one at a time; marked MEGACYCLES six times and A 3-7, B 7-15, C 15-30, D 30-78, E 78-180, F 180-405; round; 1/32" thick x 5 3/8" OD x 17/32" ID; three mtg. holes 0.067" dia. on 23/64" radius; aluminum; dull black finish; white characters. Measurements Corp. Part No. H-3516. | Frequency range indicator |
| J-101 | (MC) | CONNECTOR, receptacle; accommodates parallel bladed two contact plug; 1-9/16" lg. x 9/16" w. x 27/32" deep o/a; two mtg. holes 9/64" dia. on 1 1/8" centers; Measurements Corp. Part No. H-4853. | Holds P-101 for storage |
| J-102 | | Not used. | |
| J-103 | | Not used. | |
| J-104 | | CONNECTOR, receptacle: coaxial; BNC type, one round, straight, female, center contact; o/a dim. 3/4" lg. x 3/8" dia. with 11/16" square flange; 50 ohms nominal impedance; brass, silver plated body; locking type; "Teflon" (or equal) insert; four mtg. holes tapped #3-56 on 1/2" x 1/2" centers; Spec. MIL-C-3608 Type UG-290/U. | EXT PULSE MOD connector |
| J-105 | | Same as J-104. | EXT AMPL MOD connector |
| J-106 | | CONNECTOR, receptacle: coaxial; "BNC" type; one round, straight, female, center contact; o/a dim. 1" lg. x 3/8" dia. with 3/4" square flange; 50 ohms nominal impedance; brass, silver plated body; locking type; "Teflon" (or equal) insert; four mtg. holes tapped #3-56 on 1/2" x 1/2" centers; Spec. MIL-C-3608 Type UG-291/U. | OUTPUT connector |
| J-201 | | CONNECTOR, plug: coaxial; "BNC" type; one round, straight, male, center contact; dim. 1" lg. x 1/2" dia.; 50 ohms nominal impedance; cylindrical, brass, silver plated body; locking type; "Teflon" (or equal) insert; mounts by coupling nut, 1/2" OD with two bayonet locking slots; Spec. MIL-C-3608 Type UG-88/U; p/o Test Adapter MX1289/URM-26A. | Input connector |
| J-202 | | CONNECTOR, receptacle: coaxial; "BNC" type, one round, straight, female, center contact; o/a dim. 3/4" lg. x 3/8" dia. with 11/16" square flange; 50 ohms nominal impedance; brass, silver plated body; locking type; "Teflon" (or equal) insert; four mtg. holes for #3 screw clearance on 1/2" x 1/2" centers; Spec. MIL-C-3608 Type UG-447/U; p/o Test Adapter MX-1289/URM-26A. | Output connector |
| J-301 | | Same as J-202. p/o Fixed Attenuator CN-179/URM-26A. | Output connector |
| L-101 | (MC) | REACTOR: audio; 1 section; 15 hy p/m 20%, 30 ma DC; 450 ohms DC resistance; 2000V rms test voltage; hermetically sealed metal case; o/a dim. 1-15/16" lg. x 1-13/16" w. x 2-7/16" h.; four mtg. studs #6-32 by 3/8" lg. on 1 1/4" by 1 3/8" centers; two solder lug terminals on mtg. end; Spec. MIL-T-27; Measurements Corp. Part No. H-3662. | Modulation choke V-105 plate |
| L-102 | (MC) | COIL, R.F.: choke; 7 mh @ 1000 cycles; approx. 50 ohms DC resistance; 800 turns #38AWG copper wire, single silk enamel covered; one 4 pie universal winding; powdered iron core; 3/8" lg. x 1/2" dia.; core form 3/8" lg. x 7/32" dia.; 2 axial wire lead terminals; terminal mounted; Measurements Corp. Part No. H-4692. | RF filter measuring arm, bolometer bridge |

MAINTENANCE PARTS LIST—Continued

| REF. DESIG. | NOTES | NAME AND DESCRIPTION | LOCATING FUNCTION |
|-------------|-------|---|----------------------------------|
| L-103 | (MC) | COIL, R.F.: choke; 10 mh @ 1000 cycles; approx. 66 ohms DC resistance; 1000 turns #38 AWG copper wire, single silk enamel covered; one 4 pie winding; powdered iron core; $\frac{5}{8}$ " lg. x $\frac{9}{16}$ " dia.; core form $\frac{7}{8}$ " lg. x $\frac{7}{32}$ " dia.; 2 axial wire lead terminals; terminal mounted; Measurements Corp. Part No. H-4693. | RF filter B + input to V-110 |
| L-104 | (MC) | COIL, R.F.: choke; 4 mh @ 1000 cycles; approx. 34 ohms DC resistance; 600 turns #38AWG copper wire, single silk enamel covered; one 4 pie universal winding; powdered iron core; $\frac{5}{8}$ " lg. x $\frac{7}{16}$ " dia.; core form $\frac{7}{8}$ " lg. x $\frac{7}{32}$ " dia.; 2 axial wire lead terminals; terminal mounted; Measurements Corp. Part No. H-4691. | RF filter CW input to V-110 |
| L-105 | (MC) | COIL, R.F.: choke; 18 microhenries at 1000 cycles; 2 ohms DC resistance; 45 turns #36 AWG single Vitrotex covered copper wire; one pie universal winding; air core; $\frac{3}{16}$ " lg. x $\frac{15}{32}$ " dia. o/a; phenolic coil form $\frac{3}{16}$ " lg. x $\frac{1}{4}$ " dia.; two self lead terminations; one axial mtg. hole tapped #4-40; Measurements Corp. Part No. H-3518. | RF filter, plate supply to V-110 |
| L-106 | | Same as L-105. | RF filter, plate supply to V-110 |
| L-107 | | Same as L-105. | RF filter, plate supply to V-110 |
| L-108 | | Same as L-105. | RF filter, plate supply to V-110 |
| L-109 | | Same as L-105. | RF filter, plate supply to V-110 |
| L-110 | | Same as L-105. | RF filter, plate supply to V-110 |
| L-111 | (MC) | COIL, R.F.: choke; 15 microhenries @ 1000 cycles; approx. 0.1 ohm DC resistance; 40 turns #26AWG copper wire, enamel covered, one single layer winding, close wound; powdered iron core; $\frac{7}{8}$ " lg. x $\frac{1}{4}$ " dia.; core form $\frac{7}{8}$ " lg. x $\frac{7}{32}$ " dia.; 2 axial wire lead terminals; terminal mounted; Measurements Corp. Part No. H-4694. | RF filter heater V-110 |
| L-112 | | Same as L-111. | RF filter heater V-110 |
| L-113 | (MC) | COIL, R.F.: choke; 14 microhenries at 1000 cycles; 0.2 ohm DC resistance; 55 turns #22AWG double Nylon covered copper wire; one single layer winding on rectangular coil form; $2\frac{1}{4}$ " lg. x $1\frac{1}{2}$ " w. x $\frac{1}{8}$ " thick; polystyrene coil form $2\frac{1}{4}$ " lg. x $1\frac{1}{2}$ " w. x $\frac{1}{8}$ " thick formed to $4\frac{1}{4}$ " radius; two blind mtg. holes, one each end, 0.073" dia. x $\frac{1}{8}$ " deep; Measurements Corp. Part No. H-3588. | RF filter heater V-110 |
| L-114 | 1 | COIL, R.F.: part of cable assembly W-104; formed during installation. | Monitor pickup loop |
| L-115 | 1 | COIL, R.F.: part of resistor R-176; formed during installation. | Output pickup loop |
| L-116 | 1 | COIL, R.F.: oscillator; 53 microhenries at 1000 cycles; 3.2 ohms DC resistance; 20 turns in each of two reverse windings, #32 AWG single Vitrotex covered copper wire; two pie universal windings; tapped between windings; powdered iron core coil form; coil $\frac{7}{8}$ " lg. x $\frac{15}{32}$ " OD; coil form $\frac{7}{8}$ " lg. x $\frac{3}{8}$ " dia.; polystyrene end pieces; o/a dim. $\frac{7}{8}$ " lg. x $\frac{15}{32}$ " dia.; three wire terminations; mounts with two special brackets; Measurements Corp. Part No. H-3465. p/o L-126. | Oscillator coil for "A" band |

MAINTENANCE PARTS LIST—Continued

| REF. DESIG. | NOTES | NAME AND DESCRIPTION | LOCATING FUNCTION |
|-------------|-------|---|-------------------------------|
| L-117 | 1 | COIL, RF: oscillator; 11 microhenries at 1000 cycles; 1.2 ohms DC resistance, 9 turns in each of two reverse windings, #38 AWG single Vitrotex covered copper wire; two pie universal windings; tapped between windings; powdered iron core coil form; coil 3/16" lg. x 7/16" OD; coil form 1/2" lg. x 3/8" dia.; polystyrene end pieces; o/a dim. 7/8" lg. x 7/16" dia.; three wire terminations; mounts with two special brackets; Measurements Corp. Part No. H-3466. p/o L-127. | Oscillator coil for "B" band |
| L-118 | 1 | COIL, RF: oscillator; 3.3 microhenries; 0.3 ohm DC resistance; 21 turns #30 AWG Formex enamelled copper wire; single winding single layer; tapped at 10 1/2 turns; polystyrene solid coil form; coil 7/8" lg. x 15/32" OD; coil form 7/8" lg. x 7/16" dia.; three wire terminations; mounts with two special brackets; Measurements Corp. Part No. H-3467. p/o L-128. | Oscillator coil for "C" band |
| L-119 | 1 | COIL: RF: oscillator; 0.6 microhenry at 1000 cycles; 0.1 ohm DC resistance; 9 2/3 turns #28 AWG enamelled copper wire; single winding single layer; tapped at 4 2/3 turns; Mycalex solid coil form; coil 7/8" lg. x 11/32" OD; coil form 7/8" lg. x 5/16" dia.; three wire terminations; mounts with two special brackets; Measurements Corp. Part No. H-3599. p/o L-129. | Oscillator coil for "D" band |
| L-120 | 1 | COIL: RF: oscillator; 4 turns #18 AWG fine silver bare wire; single winding single layer; polystyrene coil form; air core; coil 3/8" lg. x 11/32" OD; coil form 3/8" lg. x 1/4" w. x 1/32" thick; two terminations are formed ends of conductor; mounts by soldering; Measurements Corp. Part No. H-3601. p/o L-130. | Oscillator coil for "E" band |
| L-121 | 1 | COIL: RF: oscillator; 1/2 turn 5/16" w. x 0.020" thick coin silver strip; bare; drilled for center tap; self supporting; air core; coil dim. 5/16" w. x 13/64" h.; ends notched; mounts by soldering; Measurements Corp. Part No. H-3602. p/o L-131. | Oscillator coil for "F" band |
| L-122 | | Same as L-103. | RF filter, B + input to V-110 |
| L-123 | | Not used. | |
| L-124 | | Not used. | |
| L-125 | | Not used. | |
| L-126 | (MC) | COIL, R.F: for 3 to 7 Mc range; comprises coil L-116, terminal assy, and mtg.; 2-1/32" lg. x 2-5/16" w. x 27/32" deep; three switch blade terminals; two mtg. holes tapped #4-40 on 1" centers; Measurements Corp. Part No. H-3603. | "A" band oscillator |
| L-127 | (MC) | COIL, R.F: for 7 to 15 Mc range; comprises coil L-117, terminal assy, and mtg.; 2-1/32" lg. x 1 3/4" w. x 23/32" deep; three switch blade terminals; two mtg. holes tapped #4-40 on 1" centers; Measurements Corp. Part No. H-3604. | "B" band oscillator |
| L-128 | (MC) | SIGNAL GENERATOR SUB-ASSY: for 15 to 30 Mc range; comprises coil L-118, resistor R-156, terminal assy, and mtg.; 2-1/32" lg. x 1 3/4" w. x 23/32" deep; three switch blade terminals; two mtg. holes tapped #4-40 on 1" centers; Measurements Corp. Part No. H-3605. | "C" band oscillator |
| L-129 | (MC) | SIGNAL GENERATOR SUB-ASSY: for 30 to 78 Mc range; comprises coil L-119, resistor R-157, terminal assy, and mtg.; 2-1/32" lg. x 1 3/4" w. x 3/4" deep; three switch blade terminals; two mtg. holes tapped #4-40 on 1" centers; Measurements Corp. Part No. H-3606. | "D" band oscillator |
| L-130 | (MC) | SIGNAL GENERATOR SUB-ASSY: for 78 to 180 Mc range; comprises coil L-120, resistor R-158, terminal assy and mtg.; 2-1/32" lg. x 2 1/4" w. x 23/32" deep; three switch blade terminals; two mtg. holes tapped #4-40 on 1" centers; Measurements Corp. Part No. H-3607. | "E" band oscillator |
| L-131 | (MC) | SIGNAL GENERATOR SUB-ASSY: for 180 to 405 Mc range; comprises coil L-121, resistor R-159, terminal assy., and mtg.; 2-1/32" lg. x 2-13/16" w. x 3/4" deep; three switch blade terminals; two mtg. holes tapped #4-40 on 1" centers; Measurements Corp. Part No. H-3608. | "F" band oscillator |

MAINTENANCE PARTS LIST—Continued

| REF. DESIG. | NOTES | NAME AND DESCRIPTION | LOCATING FUNCTION |
|-------------|-------|---|---|
| L-132 | (MC) | COIL, R.F: 50 microhenries at 1000 cycles; 5 ohms p/m 20% DC resistance; 140 turns total #38 AWG single silk enamel covered copper wire; two pie universal windings (70 turns ea.) not tapped; not shielded; wound on composition resistor; 13/32" lg. max. x 1/4" dia.; coil form 0.375" lg. x 0.140" dia.; two axial wire terminals; terminal mounted; Measurements Corp. Part No. H-4344. | RF filter, pulse input to V-110 |
| L-133 | | Same as L-132. | RF filter, pulse input to V-110 |
| M-101 | (MC) | METER, MODULATION: two scales; upper scale "OUTPUT SET TO RED LINE," single red line; lower scale "PERCENT MODULATION," 0 to 50, ten divisions, black markings on white background; ± 2% accuracy; basic meter size 3.50" dia. flange with 2.80" dia. x 2.51" deep max. barrel; 100-0-100 microampere sensitivity; panel mtg.; sealed metal case; black lacquer finish on case; self contained; three mtg. holes 0.150" dia. spaced 120 deg. apart on 1.58 in. radius; two solder lug type terminals; Measurements Corp. Part No. H-3663. | Indicates percent amplitude modulation and output voltage reference |
| O-101 | 3 | CABLE ASSY: mechanical: beryllium bronze; 0.024" ± .002" OD; single strand, 12 wires #36 AWG; 15 pounds min. breaking strength; 5 1/2" lg. approx.; terminated one end by eyelet; Measurements Corp. Part No. H-3896. | Drives monitor loop L-114 |
| O-102 | 3 | DRIVE, dial, comprises drive gear, supporting members, and mtg. hardware; 3-1/16" lg. x 3/4" h. x 1 3/8" d. o/a; mounts with one bolt #8-32 x 3/8" lg.; Measurements Corp. Part No. H-3878. | Drives frequency dial |
| O-103 | | Not used. | |
| O-104 | 3 | GEAR ASSY: comprises hub, fixed gear, movable gear, and torsion spring; 1" dia. x 13/32" lg. o/a; set screw mounted; Measurements Corp. Part No. H-3369. | Attenuator piston drive |
| O-105 | 3 | ROLLER, GUIDE: comprises roller, roller support, washer, ring, and nut; 3/8" OD x 13/16" lg. o/a; mounts by #8-32 thread on roller support; Measurements Corp. Part No. H-3908. | Coil mounting guide |
| O-106 | 3 | ROLLER, GUIDE: comprises spring and roller sub-assy; 1 1/4" lg. x 23/32" w. x 1/4" h. o/a; two mtg. holes #31 (0.120") drill on 0.200" x 0.231" centers; Measurements Corp. Part No. H-3955. | Coil mounting guide |
| O-107 | (MC) | DETENT: comprises arm, roller, eccentric, spacer, spring, washer, and retaining ring; 1-27/32" lg. x 5/8" w. x 7/16" h. o/a; single mtg. hole #26 (0.147") drill through eccentric; Measurements Corp. Part No. H-3956. | Positions coil mounting |
| O-108 | 3 | MOUNTING, COIL: brass; flat disc with six detent notches in periphery; 1/16" thick x 6-5/16" OD; mounts by center hole, 17/32" dia. flatted one side to 29/64"; stamped with circuit symbols L-126 ASSY, L-116; L-127 ASSY, L-117, L-128 ASSY, L-118, R-156, L-129 ASSY, L-119, R-157, L-130 ASSY, L-120, R-156, L-131 ASSY, L-121, R-159; Measurements Corp. Part No. H-3502. | Oscillator coil mount |
| O-109 | 4 | SPRING, helical: extension type; 0.028" dia. music wire, alloy finish; 1 1/8" free length o/a; 3/16" OD; 32 turns, close wound; parallel hook ends; Measurements Corp. Part No. H-3882. | Holds dial drive gear in mesh with tuning dial |
| O-110 | 3 | SPINDLE, roller: shaft; cold rolled steel, SAE #1020, nickel finish; 51/64" lg. x 1/4" dia.; one end threaded #8-32 NC2; flatted two sides; Measurements Corp. Part No. H-3898. | Shaft for roller O-111 |
| O-111 | 3 | ROLLER GUIDE: brass, SAE #72, free cutting; bright dip finish; 3/8" dia. x 11/64" w.; center mtg. hole 1/8" dia.; Measurements Corp. Part No. H-3899. | Coil mounting guide |
| O-112 | (NLC) | RING, retainer: carbon spring steel; open type; round cross section; for 1/8" dia. shaft; National Lockwasher Co. Part No. XRO-411; Measurements Corp. Part No. H-3954. | Retains roller O-111 |
| O-113 | 3 | ROLLER, IDLER: roller with shaft pressed in; 1/4" OD x 3/8" lg. o/a; Measurements Corp. Part No. H-3923. | Guide takeup for coil disc |

MAINTENANCE PARTS LIST—Continued

| REF. DESIG. | NOTES | NAME AND DESCRIPTION | LOCATING FUNCTION |
|-------------|-------|--|---|
| O-114 | 3 | SPRING: phosphor bronze, SAE #77, GR.B, spring temper; 0.015" thick, no finish; 1/4" lg. x 23/32" w. x 1/8" offset; two mtg. holes 0.120" dia. on 13/64" x 15/64" centers; Measurements Corp. Part No. H-3914. | Retains roller O-113 |
| O-115 | 3 | ARM DETENT: 1-11/16" lg. x 7/16" w. x 13/32" d.; single hole mtg. 0.316" dia.; Measurements Corp. Part No. H-3959. | Carries detent roller O-116 |
| O-116 | 3 | ROLLER GUIDE: brass, clean finish; 5/8" OD x 3/16" thick; axial hole 1/8" dia.; Measurements Corp. Part No. H-3905. | Coil mounting detent |
| O-117 | | Same as O-112. | Retains roller O-116 |
| O-118 | 3 | ECCENTRIC: brass, clean finish; no dim. exceeds 1"; single mtg. hole 0.147" dia.; Measurements Corp. Part No. H-3917. | Adjusts detent |
| O-119 | 3 | COLLAR, SPACER: brass, clean finish; 7/16" OD x 5/16" ID x 1/8" lg.; Measurements Corp. Part No. H-3916. | Locates detent arm |
| O-120 | 4 | SPRING, helical: torsion type; music wire, SAE #1085, 0.051" dia., alloy finish; 1-27/64" lg. x 1-1/16" w. x 5/16" deep; 1 3/8" turns, 1/2" ID; left hand; one end straight, one end hooked; Measurements Corp. Part No. H-3915. | Engages coil mtg. detent |
| O-121 | 5 | DETENT, COIL MTG.: Comprises arm (O-115), roller (O-116), retaining ring (H-119), and washer (O-117); 1-51/64" lg. x 5/8" w. x 13/32" h.; one mtg. hole 5/16" dia.; Measurements Corp. Part No. H-3909. | Detents coil mtg. |
| O-122 | 4 | STOP, dial: brass, clean finish; right angle bracket; 5/8" lg. x 1/2" w. x 1/4" h.; one mtg. hole countersunk for #6 flat head machine bolt; slotted through hole tapped #6-32 NC2; Measurements Corp. Part No. H-3886. | Limit attenuator movement |
| O-123 | | CAP, CONNECTOR & CHAIN: brass, silver plated; 9/16" lg. (excluding chain), 9/16" dia., 1 1/4" chain length; bayonet slot mtg.; "BNC" type; JAN cap and chain CW-123/U. | Protects connector J-104, J-105 |
| O-124 | 4 | SLEEVE, SPLICING: brass, silver plated; 1/4" lg. x 0.093" OD x 0.040" ID; Measurements Corp. Part No. H-4347. | Splice R-176 to W-105 |
| O-125 | 4 | SLEEVE, INSULATING: polystyrene; 5/8" lg. x 1/4" OD x 0.173" ID. Measurements Corp. Part No. H-4348. | Insulate R-176 |
| O-126 | (MC) | JIG, DIAL CALIBRATION; clear plastic plate and metal support strip; 3-3/16" lg. x 2-7/16" h. x 5/64" thick o/a; two mtg. holes 0.187" dia. on 2-11/16" centers; Measurements Corp. Part No. H-4346. | Field service recalibration of carrier freq. dial |
| P-101 | (APM) | CONNECTOR, plug: three male contacts, polarized; two blades straight, flat, parallel; rated 15 amp at 125V; rectangular, zinc coated steel body; black plastic insert; takes RG-108/U cable; o/a dim. 1 1/4" lg. excluding contacts x 1-9/16" w. x 1 1/4" h.; Automatic and Precision Mfg. Co. Part No. 920; Measurements Corp. Part No. H-4863. | Connects power |
| P-102 | | Not used. | |
| P-103 | | CONNECTOR, plug: coaxial; "BNC" type; one round, straight, male center contact; dim. 1" lg. x 1/2" dia.; 50 ohms nominal impedance; cylindrical, brass, silver plated body; locking type; "Teflon" (or equal) insert; mounts by coupling nut; 1/2" OD with two bayonet locking slots; Spec. MIL-C-3608 Type UG-88C/U. | Terminates one end of cable W-103 |
| P-104 | | Same as P-103. | Terminates one end of cable W-103 |
| P-105 | | Same as P-103. | Terminates one end of cable W-102 |
| P-106 | | Same as P-103. | Terminates one end of cable W-102 |
| P-301 | | Same as P-103. | Input connector of fixed attenuator |

MAINTENANCE PARTS LIST—Continued

| REF. DESIG. | NOTES | NAME AND DESCRIPTION | LOCATING FUNCTION |
|-------------|-------|--|--|
| R-101 | | RESISTOR, variable: wire wound; one section; 10,000 ohms p/m 10%; 4W; JAN "A" taper; 3 solder lug terminals; case per JAN-R-19; enclosed, 1.28" dia. max. x 0.62" deep max; round metal shaft, screw driver slotted, 1/4" dia. x 1/2" lg. from mtg. surface; high torque; contact arm insulated; no "off" position; mounted by bushing 3/8"-32 x 3/8" lg.; non-turn device at 9 o'clock on 0.53" radius; Spec. JAN-R-19; Type RA20A2SA103AK. | B + VOLT ADJ. grid V-103 |
| R-102 | | Same as R-101. | % MOD CAL |
| R-103 | (CC) | RESISTOR, fixed, deposited film; 60,000 ohms p/m 2%; 1W; 1" lg. x 9/32" dia.; insulated, resistant to humidity; two radial wire leads; Continental Carbon, Inc. Type X1; Measurements Corp. Part No. H-3664. | Modulator feedback to V-104 Cathode 8 |
| R-104 | | RESISTOR, fixed, composition; 100 ohms p/m 10%; 1/2W; F characteristic; 0.406" lg. max. x 0.175" dia. max.; insulated, resistant to salt water immersion; two axial wire leads; Spec. JAN-R-11 Type RC20BF101K. | Screen resistor V-102 |
| R-105 | (CC) | RESISTOR, fixed, deposited film; 15,000 ohms p/m 2%; 1W; 1" lg. x 9/32" dia.; insulated, resistant to humidity; two radial wire leads; Continental Carbon, Inc. Type X1; Measurements Corp. Part No. H-3665. | p/o voltage dividers V-103 grid |
| R-106 | | Same as R-101. | % MOD ZERO |
| R-107 | (CC) | RESISTOR, fixed, deposited film; 20,000 ohms p/m 2%; 1W; 1" lg. x 9/32" dia.; insulated, resistant to humidity; two radial wire leads; Continental Carbon, Inc. Type X1; Measurements Corp. Part No. H-3667. | p/o voltage divider V-103 screen |
| R-108 | | RESISTOR, fixed, composition; 470,000 ohms p/m 10%; 1/2W; F characteristic; 0.406" lg. max. x 0.175" dia. max.; insulated, resistant to salt water immersion; two radial wire leads; Spec. JAN-R-11, Type RC20BF474K. | Plate resistor V-103 |
| R-109 | | RESISTOR, fixed, composition; 100,000 ohms p/m 10%; 1/2W; F characteristic; 0.406" lg. x 0.175" dia. max.; insulated, resistant to salt water immersion; two radial wire leads; Spec. JAN-R-11 Type RC20BF104K. | p/o voltage divider V-103 cathode |
| R-110 | | RESISTOR, fixed, composition; 220,000 ohms \pm 10%; 1/2W; F characteristic; 0.406" lg. x 0.175" dia. max.; insulated, resistant to salt water immersion; two radial wire leads; Spec. JAN-R-11, Type RC20BF224K. | Plate resistor V-104 |
| R-111 | (CC) | RESISTOR, fixed, deposited film; 800K ohms \pm 2%; 1w, 1" lg. x 9/32" dia.; insulated, resistant to humidity; two radial wire leads; Continental Carbon, Inc. Type X1; Measurements Corp. Part No. H-4689. | p/o bucking circuit, M-101 |
| R-112 | (CC) | RESISTOR, fixed, deposited film; 265,000 ohms \pm 2%; 1w; 1" lg. x 9/32" dia.; insulated, resistant to humidity; two radial wire leads; Continental Carbon, Inc. Type X1; Measurements Corp. Part No. H-3669. | Plate resistor V-104 term 1 |
| R-113 | (CC) | RESISTOR, fixed, deposited film; 5,000 ohms \pm 2%; 1w; 1" lg. x 9/32" dia., insulated, resistant to humidity, two radial wire leads; Continental Carbon, Inc. Type X1; Measurements Corp. Part No. H-3670. | Coupling resistor V-104, grid 2 |
| R-114 | | RESISTOR, fixed, composition; 10,000 ohms \pm 10%; 1/2w; F characteristic; 0.406" lg. x 0.175" dia. max.; insulated, resistant to salt water immersion; two radial wire leads; Spec. JAN-R-11, Type RC20BF103K. | Cathode resistor V-104 term 8 |
| R-115 | | RESISTOR, fixed, composition; 5600 ohms p/m 10%; 1/2W; F characteristic; 0.406" lg. x 0.175" dia. max.; insulated, resistant to salt water immersion; two radial wire leads; Spec. JAN-R-11 Type RC20BF562K. | Cathode resistor V-104 term 8 |
| R-116 | | RESISTOR, fixed, composition; 1 megohm p/m 10%; 1/2W, F characteristic; 0.406" lg. x 0.175" dia. max.; insulated, resistant to salt water immersion; two radial wire leads; Spec. JAN-R-11 Type RC20BF105K. | Grid resistor V-104 term 7 |
| R-117 | | RESISTOR, fixed, composition; 510 ohms p/m 5%; 1/2W; F characteristic; 0.406" lg. x 0.175" dia. max.; insulated, resistant to salt water immersion; two radial wire leads; Spec. JAN-R-11 Type RC20BF511J. | Cathode resistor V-105 |
| R-118 | | Same as R-116. | Grid resistor V-105 |

MAINTENANCE PARTS LIST—Continued

| REF. DESIG. | NOTES | NAME AND DESCRIPTION | LOCATING FUNCTION |
|-------------|-------|---|---------------------------------------|
| R-119 | | RESISTOR, fixed, composition; 10 megohms p/m 10%; 1/2W; F characteristic; 0.406" lg. x 0.175" dia. max.; insulated, resistant to salt water immersion; two radial wire leads; Spec. JAN-R-11 Type RC20BF106K. | Grid resistor V-109 term 7 |
| R-120 | | Same as R-110. | Plate resistor V-109 term 1 |
| R-121 | | Same as R-109. | Plate filter V-109 |
| R-122 | | Same as R-110. | Grid resistor V-108 |
| R-123 | | Same as R-116. | Grid resistor V-107 |
| R-124 | | Same as R-109. | Plate resistor V-109 term 6 |
| R-125 | | Same as R-109. | Plate resistor V-106 |
| R-126 | | RESISTOR, variable: wire wound; one section; 200 ohms p/m 10%; 4W; 3 solder lug terminals; phenolic body; enclosed; 1.28" dia. max. x 0.62" deep max.; round metal shaft, screw driver slotted, 1/4" dia. x 1/2" lg. from mtg. surface; high torque; contact arm insulated; no "off" position; mounted by bushing 3/8"-32 x 3/8" lg.; non-turn device located at 9 o'clock on 0.53" radius; Spec. JAN-R-19, Type RA20A2SA201AK. | OUTPUT CAL potentiometer |
| R-127 | | Same as R-126. | OUTPUT METER ZERO potentiometer |
| R-128 | | RESISTOR, fixed, wire wound; low inductance winding; 1000 ohms p/m 1%; 1/3W; body dim excluding terminals 5/8" lg. x 21/32" OD; varnish coated, resistant to humidity; two solder lug terminals; axial mtg. hole clearance for #6 screw; Spec. MIL-R-93 Type RB16BK10000F. | p/o bolometer bridge |
| R-129 | | Same as R-128. | p/o bolometer bridge |
| R-130 | (CC) | RESISTOR, fixed, deposited film; 400,000 ohms ± 2%; 1w; 1" lg. x 9/32" dia.; insulated, resistant to humidity; two radial wire leads; Continental Carbon, Inc. Type X1; Measurements Corp. Part No. H-3671. | p/o AF osc. tuning V-106 grid |
| R-131 | | Same as R-130. | p/o AF osc. tuning V-106 grid |
| R-132 | | Same as R-112. | p/o AF osc. tuning S-104 |
| R-133 | | Same as R-112. | p/o AF osc. tuning S-104 |
| R-134 | | Same as R-115. | EXT AMPL MOD input, J-105 |
| R-135 | (CC) | RESISTOR, fixed, deposited film; 3000 ohms ± 2%; 1w; 1" lg. x 9/32" dia.; insulated, resistant to humidity; two radial wire leads; Continental Carbon, Inc. Type X1; Measurements Corp. Part No. H-3490. | AF osc. feedback V-106 cathode |
| R-136 | | Same as R-109. | Screen resistor V-106 |
| R-137 | | Same as R-109. | Screen resistor V-106 |
| R-138 | | RESISTOR, fixed, composition; 4700 ohms ± 10%; 2w; F characteristic; body dim. excluding terminals 0.750" lg. max. x 0.370" dia. max.; insulated, resistant to salt water immersion; two axial wire leads; Spec. JAN-R-11, Type RC42BF472K. | Plate resistor V-107 |
| R-139 | | Same as R-138. | Plate resistor V-107 |

MAINTENANCE PARTS LIST—Continued

| REF. DESIG. | NOTES | NAME AND DESCRIPTION | LOCATING FUNCTION |
|-------------|-------|---|---|
| R-140 | | RESISTOR, fixed, composition: 1,000 ohms \pm 10%; $\frac{1}{2}$ W; F characteristic; 0.406" lg. x 0.175" dia.; insulated, resistant to salt water immersion; two radial wire leads; Spec. JAN-R-11 Type RC20BF102K. | Cathode resistor V-107 |
| R-141 | (CC) | RESISTOR, fixed, deposited film: 2500 ohms \pm 2%; lw; 1" lg. x $\frac{9}{32}$ " dia.; insulated, resistant to humidity; two radial wire leads; Continental Carbon, Inc. Type X1; Measurements Corp. Part No. H-3489. | Plate resistor V-108 |
| R-142 | | Same as R-141. | Plate resistor V-108 |
| R-143 | | RESISTOR, fixed, composition: 33 ohms \pm 10%; $\frac{1}{2}$ W; F characteristic; 0.406" lg. x 0.175" dia.; insulated, resistant to salt water immersion; two radial wire leads; Spec. JAN-R-11 Type RC20BF330K. | Voltage divider, bolometer bridge excitation |
| R-144 | | RESISTOR, fixed, composition: 10 ohms p/m 10%; $\frac{1}{2}$ W; F characteristic; 0.406" lg. x 0.175" dia. max.; insulated, resistant to salt water immersion; two radial wire leads; Spec. JAN-R-11 Type RC20BF100K. | Voltage divider, bolometer bridge excitation |
| R-145 | | RESISTOR, variable: composition; one section; 50,000 ohms p/m 20%; $\frac{1}{4}$ W; C taper; 3 solder lug terminals; phenolic body, metal case; 1- $\frac{9}{32}$ " dia. x $\frac{21}{32}$ " deep; flatted metal shaft, $\frac{1}{4}$ " dia. x $\frac{7}{8}$ " lg. from mtg. surface; normal torque; contact arm insulated; no "off" position; mounted by bushing, $\frac{3}{8}$ "-32 x $\frac{3}{8}$ " lg.; non-turn device on 0.531" radius at 9 o'clock; Spec. JAN-R-94; Type RV3ATFD503D. | % MOD control |
| R-146 | | Not used. | |
| R-147 | | Same as R-140. | RF filter, pulse input to V-110 |
| R-148 | | RESISTOR, fixed, composition: 51 ohms p/m 5%; $\frac{1}{2}$ W; F characteristic; 0.406" lg. x 0.175" dia. max.; insulated, resistant to salt water immersion; two radial wire leads; Spec. JAN-R-11 Type RC20BF510J. | RF filter, plate input to V-110 |
| R-149 | 4 | WIRE, ELECTRICAL: 1.0 ohm p/m 20%; $\frac{1}{2}$ W; #30 AWG x $\frac{4}{16}$ " lg.; manganin wire; double nylon covered; solders in place; Measurements Corp. Part No. H-3672. | Resonance suppressor, bolometer bridge |
| R-150 | 1 | RESISTOR, fixed, composition: 68 ohms p/m 5%; $\frac{1}{2}$ W; F characteristic; body dim. excluding terminals $\frac{13}{32}$ " lg. x 0.148" max. dia.; insulated; resistant to salt water immersion; two axial wire leads; Spec. JAN-R-11, same as Type RC20BF680J except limited to diameter stated above. Must be adjusted to proper resistance value after installation. Measurements Corp. No. H-3938. | Monitor loop termination |
| R-151 | 1 | RESISTOR, THERMAL: bolometer; resistance 120 to 240 ohms at 70° F ambient temp.; $\frac{1}{2}$ ma nominal operating current; for AC use; element sealed in evacuated glass tube 2- $\frac{1}{16}$ " lg. x $\frac{5}{16}$ " dia.; mounts by two axial wire leads each $\frac{1}{4}$ " lg.; must match R-155; Measurements Corp. Part No. H-3559. p/o Resistor Kit R-174. | Measuring bolometer |
| R-152 | | RESISTOR, fixed, composition: 22,000 ohms p/m 10%; $\frac{1}{2}$ W; F characteristic; 0.406" lg. x 0.175" dia. max.; insulated, resistant to salt water immersion; two radial wire leads; Spec. JAN-R-11 Type RC20BF223K. | Grid resistor V-110 |
| R-153 | | Not used. | |
| R-154 | | Same as R-104. | Suppressor resistor in oscillator compartment |
| R-155 | | Same as R-151 (Must match R-151). | Balancing bolometer |
| R-156 | | Same as R-140, p/o sub-assy L-128. | Limiting resistor |
| R-157 | | Same as R-140, p/o sub-assy L-129. | Limiting resistor |
| R-158 | | Same as R-140, p/o sub-assy L-130. | Limiting resistor |
| R-159 | | Same as R-140, p/o sub-assy L-131. | Limiting resistor |

MAINTENANCE PARTS LIST—Continued

| REF. DESIG. | NOTES | NAME AND DESCRIPTION | LOCATING FUNCTION |
|-------------|-------|---|------------------------------|
| R-160 | | RESISTOR, fixed, wire wound: 2000 ohms p/m 5%; 12W; body dim excluding terminals 2-1/16" lg. x 19/32" OD; cement coated, resistant to moisture; two tab type terminals; panel mounted with #6 screw; Spec. JAN-R-26A Type RW32F202. | Standby heater |
| R-161 | | Same as R-160. | Standby heater |
| R-162 | | RESISTOR, fixed, composition: 47,000 ohms p/m 10%; 1/2 W; F characteristic; 0.406" lg. x 0.175" dia. max.; insulated, resistant to salt water immersion; two radial wire leads; Spec. JAN-R-11 Type RC20BF473K. | Plate resistor V-109 |
| R-163 | (CC) | RESISTOR, fixed, deposited film; 35,000 ohms p/m 2%; 1W; 1" lg. x 9/32" dia.; insulated, resistant to humidity, two radial wire leads; Continental Carbon, Inc. Type XI; Measurements Corp. Part No. H-3676. | % MOD CAL shunt |
| R-164 | | Not used. | |
| R-165 | | Not used. | |
| R-166 | | Not used. | |
| R-167 | | Not used. | |
| R-168 | | Not used. | |
| R-169 | | RESISTOR, fixed, wire wound: 10,000 ohms p/m 5%; 12W; body dim. excluding terminals 2-1/16" lg. max. x 19/32" OD max.; cement coated resistant to moisture; two tab type terminals; panel mounted by #6 screw; Spec. JAN-R-26A Type RW32F103. | Shunt for regulator V-102 |
| R-170 | | Not used. | |
| R-171 | | Not used. | |
| R-172 | | Not used. | |
| R-173 | | Not used. | |
| R-174 | (MC) | RESISTOR KIT: comprises matched bolometers R-151, R-155 and termination resistor R-150. Measurements Corp. Part No. H-3970. | Maintenance replacement |
| R-175 | | Not used. | |
| R-176 | (AB) | RESISTOR, fixed, composition: 47 ohms p/m 5%; 1/2 W; F characteristic; body dim. excluding terminals 0.375" lg. x 0.140" dia.; insulated, resistant to salt water immersion; two axial wire leads; Spec. JAN-R-11, same as Type RC20BF470J except limited to dimensions stated above. Must be adjusted to proper resistance value after installation. P/o Cable Assy W-107; Measurements Corp. Part No. H-3674. | Output pickup loop |
| R-201 | | Same as R-176—p/o Test Adapter MX-1289/URM-26A. | Terminating resistor |
| R-301 | (AB) | RESISTOR, fixed, composition: 220 ohms p/m 5%; 1/2 W; F characteristic; body dim. excluding terminals 0.375" lg. x 0.140" dia.; insulated, resistant to salt water immersion; two axial wire leads; Spec. JAN-R-11, same as type RC20BF221J except limited to dimensions stated above. Must be adjusted to proper resistance value after installation. Measurements Corp. Part No. H-3940, p/o Fixed Attenuator CN-179/URM-26A. | p/o attenuator |
| R-302 | (AB) | RESISTOR, fixed, composition: 56 ohms p/m 5%; 1/2 W; F characteristic; body dim. excluding terminals 0.375" lg. x 0.140" dia.; insulated, resistant to salt water immersion; two axial wire leads; Spec. JAN-R-11, same as Type RC20BF560J except limited to dimensions stated above. Must be adjusted to proper resistance value after installation. Measurements Corp. Part No. H-3939; p/o Fixed Attenuator CN-179/URM-26A. | p/o attenuator |
| R-303 | | Same as R-302—p/o Fixed Attenuator CN-179/URM-26A. | p/o attenuator |
| S-101 | | SWITCH, toggle: DPDT; 5 amp, 125V AC; phenolic body; dim. excluding terminals, barriers, bushing, and handle, 1-21/64" lg. x 49/64" w. x 49/64" deep max.; bat handle 11/16" lg.; locking action; six solder lug terminals on back; Spec. JAN-S-23, Type S52N. | ON—POWER switch |
| S-102 | | Same as S-101. | METER, OUTPUT — % MOD switch |
| S-103 | | SWITCH, toggle: SPDT; 5 amp, 125V AC; phenolic body; dim. excluding terminals, barriers, bushing and handle 1-9/32" lg. x 23/32" w. x 23/32" deep max.; bat handle 11/16" lg.; locking action; three soldering terminals on back; Spec. JAN-S-23 Type ST13D. | NORMAL—EXT PULSE ONLY switch |

MAINTENANCE PARTS LIST—Continued

| REF. DESIG. | NOTES | NAME AND DESCRIPTION | LOCATING FUNCTION |
|-------------|-------|---|--|
| S-104 | (MC) | SWITCH, rotary: two sections; 11 positions max.; non-pile-up; 4 poles 4 positions; brass contacts, silver plated; phenolic sections; 2-29/32" lg. x 15/8" w. x 17/8" h.; mounts by bushing 3/8"-32 x 3/8" lg.; round shaft, with flat, 3/4" lg. x 1/4" dia.; solder lug terminals; non-shorting contacts; Measurements Corp. Part No. H-3677. | AMPLITUDE MODULATION switch |
| T-101 | (MC) | TRANSFORMER, power, step-down and step-up: hermetically sealed metal case; input 115V 50 to 1000 cycles single phase; five output windings; sec. #1, CT 315-0-315 v @ 0.05 amp; sec. #2, 6.3v @ 1.0 amp; sec. #3, 6.4v @ 3.0 amp; sec. #4, 6.3v @ 0.1 amp; sec. #5, 0.3v @ 0.1 amp; 2,000v insulation; impregnated and potted; 3-9/16" lg. x 3-1/16" w. x 37/8" h.; 13 solder lug terminals on mounting end; four mtg. studs #8-32 x 3/8" lg. on 25/8" x 21/8" centers; shield between primary and all other windings; shield between sec. #5 and other windings; per Spec. MIL-T-27; Measurements Corp. Part No. H-4699. | Power transformer |
| TB-101 | 4 | TERMINAL BOARD: molded phenolic board; 42 turret type terminals; w/o barrier; 8" lg. x 2" w. x 9/16" h.; two mtg. inserts, tapped #6-32 spaced at 43/4" centers; no marking; Measurements Corp. Part No. H-3698. | Power unit resistor-capacitor mounting |
| TB-102 | 4 | TERMINAL BOARD: molded phenolic board; 18 turret type terminals; w/o barrier; 31/2" lg. x 2" w. x 9/16" h.; two mtg. inserts, tapped #6-32 spaced at 21/4" centers; terminal number 1 to 18 inclusive marked on board; Measurements Corp. Part No. H-3695. | Power unit cable termination |
| TB-103 | 4 | TERMINAL BOARD: molded phenolic board; 31 turret type terminals; w/o barrier; 53/4" lg. x 21/8" w. x 15/32" h.; two mtg. holes 0.156" dia. spaced at 3-9/16" centers; no marking; Measurements Corp. Part No. H-3696. | Audio oscillator resistor-capacitor mounting |
| TB-104 | 4 | TERMINAL BOARD: molded phenolic board; 14 turret type terminals; w/o barrier; 41/2" lg. x 3" w. x 15/32" h.; two mtg. holes 0.156" dia. spaced at 23/4" centers; schematic symbols marked on board; C-105, C-106, C-107, C-108, R-119, R-120, R-121, R-122, R-123, R-124, R-125, R-162; Measurements Corporation Part No. H-3697. | Output meter resistor-capacitor mounting |
| TB-105 | 4 | TERMINAL BOARD: molded phenolic board; w/o terminals; w/o barrier; 31/8" lg. x 11/4" w. x 1/16" thick; two mtg. holes 0.156" dia. spaced at 11/8" x 11/16" C to C; Measurements Corporation Part No. H-3449. | RF oscillator suppressor mounting |
| TB-106 | 4 | TERMINAL BOARD: molded phenolic; three solder lugs spaced on 3/8" centers; w/o barrier; o/a dim. 11/8" lg. x 3/8" w. x 1/16" thk.; one mtg. hole, #6 clearance in center lug; no marking; Cinch Mfg. Corp. Part No. 1520; Measurements Corp. Part No. H-3972. | Amplifier cabling tie point |
| TB-107 | | Same as TB-106. | Amplifier cabling tie point |
| TB-108 | (CIN) | TERMINAL BOARD: molded phenolic; two solder lugs spaced on 3/8" centers; w/o barrier; o/a dim. 3/4" lg. x 3/8" w. x 1/16" thk.; one mtg. hole, #6 clearance in one lug; no marking; Cinch Mfg. Corp. No. 1510; Measurements Corp. Part No. H-3941. | Tie point for R-148 |
| TB-109 | (CIN) | TERMINAL BOARD: molded phenolic; two solder lugs spaced on 3/8" centers; w/o barrier; o/a dim. 3/4" lg. x 3/8" w. x 1/16" thk.; one mtg. hole, #6 clearance in one lug; no marking; Cinch Mfg. Corp. No. 1513; Measurements Corp. Part No. H-3942. | Tie point for R-155 |
| TB-110 | | Same as TB-106. | Tie point for XE-103 |
| V-101 | | ELECTRON TUBE: double diode; JAN Type 6X4WA. | B + rectifier |
| V-102 | | ELECTRON TUBE: tetrode; JAN Type 6005. | Voltage regulator |
| V-103 | | ELECTRON TUBE: pentode; JAN Type 6AU6WA. | Voltage regulator |
| V-104 | | ELECTRON TUBE: double triode; JAN Type 5814. | Vacuum tube voltmeter and modulation amplifier |

MAINTENANCE PARTS LIST—Continued

| REF. DESIG. | NOTES | NAME AND DESCRIPTION | LOCATING FUNCTION |
|-------------|-------|--|------------------------|
| V-105 | | Same as V-102. | Modulator |
| V-106 | | Same as V-103. | Audio oscillator |
| V-107 | | Same as V-102. | Audio oscillator |
| V-108 | | Same as V-104. | Meter rectifier |
| V-109 | | ELECTRON TUBE: double triode; JAN Type 5751. | Meter amplifier |
| V-110 | | ELECTRON TUBE: triode; JAN Type 6F4. | RF oscillator |
| W-101 | (MC) | CABLE ASSY, power, electrical; Type RG-108/U r-f cable; two standard conductors No. 20 AWG; overall length approx. 8 ft.-4 in.; outer covering cut away approx. 1 $\frac{1}{8}$ " one end, 12" other end; conductors skinned $\frac{3}{8}$ " each end; Measurements Corporation Part No. H-4698. | Power cable |
| W-102 | (MC) | CORD: RF coaxial cable, JAN Type RG-58/U; 4 ft. lg. o/a; RF connector JAN Type UG-88C/U on each end; AN designation Cord, CG-409/U (4'-0"); Measurements Corp. Part No. H-3422. | RF cable |
| W-103 | | Same as W-102. | |
| W-104 | 5 | CABLE ASSY, RF: RF coaxial cable, JAN Type RG-55/U; 9" lg. o/a; 8" lg. over end washers; one end termination, 5/16" lg. bare conductor, 1/16" lg. dielectric beyond end washer and $\frac{3}{8}$ " OD sleeve over outer braid; other end termination, $\frac{1}{2}$ " long bare conductor, $\frac{1}{8}$ " lg. dielectric beyond end washer and 11/64" OD sleeve over outer braid; Measurements Corp. Part No. H-3512. | Monitor cable |
| W-105 | 5 | CABLE ASSY, RF: RF coaxial cable JAN Type RG-55/U; 23" lg. o/a; one end termination, connector JAN Type UG-291/U; other end termination, $\frac{3}{8}$ " lg. bare conductor, 1/16" lg. dielectric beyond end washer and $\frac{1}{4}$ " OD sleeve over outer braid; Measurements Corp. Part No. H-3514. | Output cable |
| W-106 | 5 | CABLE ASSY, RF: RF coaxial cable JAN Type RG-55/U; 7 $\frac{1}{2}$ " lg. o/a; 6 $\frac{1}{2}$ " lg. over end eyelets; each end termination, 3/16" lg. bare conductor, 5/16" lg. dielectric beyond end eyelet; shield terminated between concentric eyelets; Measurements Corp. Part No. H-3943. | Plate filter V-110 |
| W-107 | 5 | CABLE ASSEMBLY, RF: comprises output cable W-105 and output loop resistor R-176; completely assembled with splicing sleeve and outer insulator; $\frac{1}{4}$ " O.D. x 23" lg.; Measurements Corp. Part No. H-4953. | Output loop and cable |
| XE-101 | | Not used. | |
| XE-102 | (DLC) | LAMPHOLDER; single holder; accommodates double contact bayonet candelabra base lamp; rated 125 V, 75 watts; brass body; 29/32" lg. x 1-11/16" w. x $\frac{5}{8}$ " deep; two wire lead terminations; two mtg. holes 5/32" dia. on 1-1/16" centers. Dial Light Co. of Amer. Part No. 12-225; Measurements Corp. Part No. H-4688. | Mounts E-102 |
| XE-103 | (DLC) | LAMPHOLDER; single holder; accommodates double contact bayonet candelabra base lamp; rated 125 V; 75 watts; steel shell; 1-25/32" lg. x $\frac{5}{8}$ " w. x 1" h.; two wire lead terminals; mounting slot 5/32" x $\frac{3}{8}$ "; Dial Light Co. of Amer. Part No. 12-72; Measurements Corp. Part No. H-3661. | Mounts E-103 |
| XF-101 | (BUS) | FUSEHOLDER: extractor-post type; rated 250 V, 15 amp; accommodates one cartridge type fuse 1 $\frac{1}{4}$ " lg. x $\frac{1}{4}$ " dia.; phenolic body; brass contacts, axial pressure type; o/a dim. of fuseholder 2-9/64" lg. x 11/16" dia.; two solder lug terminals; mounts in single $\frac{1}{2}$ " dia. hole; Bussman Mfg. Co. Part No. HKP-H; Measurements Corp. Part No. H-3884. | Holds fuse F-101 |
| XF-102 | | Same as XF-101. | Holds fuse F-102 |
| XF-103 | | Same as XF-101. | Holds spare fuse F-103 |
| XF-104 | | Same as XF-101. | Holds spare fuse F-104 |

MAINTENANCE PARTS LIST—Continued

| REF. DESIG. | NOTES | NAME AND DESCRIPTION | LOCATING FUNCTION |
|-------------|-------|--|---------------------------------------|
| XV-101 | | SOCKET, electron tube: seven contacts, copper base alloy silver plated; miniature size; includes metal shock shield, 0.8" dia. x $\frac{5}{8}$ " h.; includes center shield; oval shape; o/a excluding terminals, $1\frac{1}{8}$ " lg. x 0.8" w. x $\frac{25}{32}$ " h.; molded plastic body; one piece saddle mtg.; requires $\frac{21}{32}$ " dia. chassis hole and two holes 0.125" dia. spaced $\frac{7}{8}$ " C to C; Spec. JAN-S-28A, Type TS102P01. | Holds V-101 |
| XV-102 | | Same as XV-101. | Holds V-102 |
| XV-103 | | Same as XV-101. | Holds V-103 |
| XV-104 | | SOCKET, electron tube: nine contact noval, copper base alloy silver plated; miniature size; includes metal shock shield 0.94" dia. x $\frac{5}{8}$ " h.; includes center shield; oval shape; o/a excluding terminals, $1\frac{3}{8}$ " lg. x 0.94" w. x $\frac{25}{32}$ " h.; molded plastic body; one piece saddle mtg.; requires $\frac{49}{64}$ " dia. chassis hole and two holes 0.125" dia. spaced $1\frac{1}{8}$ " C to C; Spec. JAN-S-28A, Type TS103P01. | Holds V-104 |
| XV-105 | | Same as XV-101. | Holds V-105 |
| XV-106 | | Same as XV-101. | Holds V-106 |
| XV-107 | | Same as XV-101. | Holds V-107 |
| XV-108 | | Same as XV-104. | Holds V-108 |
| XV-109 | | Same as XV-104. | Holds V-109 |
| XV-110 | | p/o Capacitor Assy C-128. | Holds V-110 |
| | 2 | ATTENUATOR, FIXED: 50 ohms nominal impedance input and output; 20db attenuation; input termination UG-88C/U connector; output termination UG-447/U connector; o/a dim. 5" lg. x $1\frac{1}{16}$ " wide x $\frac{3}{4}$ " deep; AN Type CN-179/URM-26A; Measurements Corp. Part No. HA-3423. | Attenuates output |
| | 2 | ADAPTER, TEST: 50 ohms nominal impedance; input termination UG-88/U connector; output termination UG-447/U connector; o/a dim. $2\frac{7}{16}$ " lg. x $1\frac{1}{16}$ " wide x $\frac{3}{4}$ " deep; AN Type MX-1289/URM-26A; Measurements Corp. Part No. HA-3425. | Termination for RF output cable W-102 |

TABLE 8-2. STOCK NUMBER IDENTIFICATION

| REF. DESIG. | STOCK NUMBER | | | |
|-------------|--------------|------------------|--------------|-----------|
| | FEDERAL | STANDARD NAVY | SIGNAL CORPS | AIR FORCE |
| C-101 | | N16-C-51515-5280 | | |
| C-102 | | N16-C-47297-3175 | | |
| C-103 | | N16-C-33622-5588 | | |
| C-105 | | N16-C-33627-7705 | | |
| C-106 | | N16-C-46347-3081 | | |
| C-109 | | N16-C-49197-3878 | | |
| C-110 | | N16-C-31080-2214 | | |
| C-112 | | N16-C-19111-1118 | | |
| C-113 | | N16-C-18631-1933 | | |
| C-116 | | N16-C-19111-1251 | | |
| C-117 | | N16-C-17091-7990 | | |
| C-123 | | N16-C-99999-746 | | |
| C-128 | | N16-C-66269-4999 | | |
| C-131 | | N16-C-18631-1621 | | |
| E-101 | | GM17-L-6305-46 | | |
| E-102 | | N17-L-3911-150 | | |
| E-103 | | GM17-L-6811 | | |
| E-104 | | N16-P-460523-525 | | |
| E-106 | | N16-K-700065-542 | | |
| E-107 | | N16-K-700099-201 | | |
| E-108 | | N16-K-700337-327 | | |
| EV-101 | | N16-S-34607-6039 | | |
| EV-103 | | N16-S-34557-8351 | | |
| EV-104 | | N16-S-34576-6514 | | |
| F-101 | | N17-F-16320-25 | | |
| H-101 | | N43-S-52329-4800 | | |
| H-103 | | N16-M-60918-1606 | | |
| H-104 | | N17-P-22376-8748 | | |
| H-105 | | N42-F-3649-2000 | | |
| H-106 | | N16-P-403561-146 | | |
| H-107 | | N16-P-403561-143 | | |
| H-108 | | N16-H-161001-181 | | |
| H-109 | | N17-B-775001-212 | | |
| H-111 | | N16-H-150001-333 | | |
| H-113 | | N17-G-151841-632 | | |
| H-115 | | N17-S-46774-5671 | | |
| H-116 | | N16-N-88601-1055 | | |
| H-117 | | N42-F-3649-702 | | |
| H-118 | | N43-W-22849-7232 | | |
| H-119 | | N43-W-22849-7281 | | |
| H-121 | | N43-W-7508-2579 | | |
| H-122 | | G41-W-2444 | | |
| H-123 | | G41-W-2445-5 | | |
| H-124 | | G41-W-2446 | | |
| H-125 | | G41-W-2449 | | |

TABLE 8-2. STOCK NUMBER IDENTIFICATION—Continued

| REF. DESIG. | STOCK NUMBER | | | |
|----------------|--------------|-------------------|--------------|-----------|
| | FEDERAL | STANDARD NAVY | SIGNAL CORPS | AIR FORCE |
| I-101A | | N17-L-076657-9199 | | |
| I-101B | | N17-I-250620-0101 | | |
| I-102 | | N16-D-46357-2055 | | |
| I-103 | | N16-S-117102-104 | | |
| I-104 | | N16-S-117101-810 | | |
| I-105 | | N16-M-16001-1008 | | |
| J-101 | | | | |
| J-104 | | N17-C-73108-1267 | | |
| J-106 | | N17-C-73108-1262 | | |
| J-201 | | N17-C-71408-5333 | | |
| J-202 | | N17-C-73108-1259 | | |
| L-101 | | N16-R-29315-8801 | | |
| L-102 | | N16-C-75168-8496 | | |
| L-103 | | N16-C-76285-7439 | | |
| L-104 | | N16-C-75794-7249 | | |
| L-105 | | N16-C-73273-1278 | | |
| L-111 | | | | |
| L-113 | | N16-C-73197-8563 | | |
| L-126 | | N16-C-73586-6725 | | |
| L-127 | | N16-C-73148-1721 | | |
| L-128 | | N16-G-67501-1023 | | |
| L-129 | | N16-G-67501-1022 | | |
| L-130 | | N16-G-67501-1024 | | |
| L-131 | | N16-G-67501-1025 | | |
| L-132 | | N16-C-73539-5771 | | |
| M-101 | | N17-M-26638-2206 | | |
| O-101 | | N16-C-10881-1231 | | |
| O-102 | | N16-D-900411-122 | | |
| O-104 | | N16-G-500001-465 | | |
| O-105 | | N16-R-751251-122 | | |
| O-106 | | N16-R-751251-127 | | |
| O-107 | | N16-D-200001-121 | | |
| O-108 | | N16-M-61584-7501 | | |
| O-109 | | N17-S-46748-7001 | | |
| O-110 | | N16-S-550121-108 | | |
| O-111 | | N16-R-751251-128 | | |
| O-112 | | N42-R-2057-4140 | | |
| O-113 | | N16-R-751371-105 | | |
| O-114 | | N17-S-46768-5558 | | |
| O-115 | | N16-A-700001-261 | | |
| O-116 | | N16-R-751251-126 | | |
| O-118 | | N16-E-300066-664 | | |

TABLE 8-2. STOCK NUMBER IDENTIFICATION—Continued

| REF. DESIG. | STOCK NUMBER | | | |
|-------------|--------------|-------------------|--------------|-----------|
| | FEDERAL | STANDARD NAVY | SIGNAL CORPS | AIR FORCE |
| O-119 | | N16-C-600001-392 | | |
| O-120 | | N17-S-46844-9361 | | |
| O-121 | | N16-D-200001-132 | | |
| O-122 | | N16-S-685341-114 | | |
| O-123 | | N17-C-200964-601 | | |
| O-126 | | N16-J-300001-0150 | | |
| P-101 | | | | |
| P-103 | | N17-C-71408-9255 | | |
| R-101 | | N16-R-91291-4930 | | |
| R-103 | | N16-R-55023-342 | | |
| R-104 | | N16-R-49580-811 | | |
| R-105 | | N16-R-54834-181 | | |
| R-107 | | N16-R-54861-241 | | |
| R-108 | | N16-R-50822-811 | | |
| R-109 | | N16-R-50633-811 | | |
| R-110 | | N16-R-50714-811 | | |
| R-111 | | | | |
| R-112 | | N16-R-55235-776 | | |
| R-113 | | N16-R-54636-241 | | |
| R-114 | | N16-R-50282-811 | | |
| R-115 | | N16-R-50165-811 | | |
| R-116 | | N16-R-50975-811 | | |
| R-117 | | N16-R-49786-431 | | |
| R-119 | | N16-R-51326-811 | | |
| R-126 | | N16-R-90298-5400 | | |
| R-128 | | N16-R-79098-8629 | | |
| R-130 | | N16-R-55293-181 | | |
| R-135 | | N16-R-54546-181 | | |
| R-138 | | N16-R-50130-0469 | | |
| R-140 | | N16-R-49922-811 | | |
| R-141 | | N16-R-54528-241 | | |
| R-143 | | N16-R-49364-811 | | |
| R-144 | | N16-R-49238-811 | | |
| R-145 | | N16-R-87851-9285 | | |
| R-148 | | N16-R-49444-431 | | |
| R-149 | | N17-W-237981-130 | | |
| R-150 | | N16-R-49498-431 | | |
| R-152 | | N16-R-50372-811 | | |
| R-160 | | N16-R-66103-9486 | | |
| R-162 | | N16-R-50480-811 | | |
| R-163 | | N16-R-54924-241 | | |
| R-169 | | N16-R-66397-4791 | | |
| R-174 | | N16-R-93601-1046 | | |

TABLE 8-2. STOCK NUMBER IDENTIFICATION—Continued

| REF. DESIG. | STOCK NUMBER | | | |
|-----------------|--------------|------------------|--------------|-----------|
| | FEDERAL | STANDARD NAVY | SIGNAL CORPS | AIR FORCE |
| R-176 | | N16-R-49426-433 | | |
| R-301 | | N16-R-49660-438 | | |
| R-302 | | N16-R-49462-438 | | |
| S-101 | | N17-S-73959-1025 | | |
| S-103 | | N17-S-72018-7701 | | |
| S-104 | | N17-S-65044-1516 | | |
| T-101 | | N17-T-74265-2930 | | |
| TB-101 | | N17-B-78283-1071 | | |
| TB-102 | | N17-B-78113-7026 | | |
| TB-103 | | N17-B-78227-3251 | | |
| TB-104 | | N17-B-78036-6751 | | |
| TB-105 | | N17-B-77413-5746 | | |
| TB-106 | | | | |
| TB-108 | | N17-B-77482-9221 | | |
| TB-109 | | N17-B-77482-9216 | | |
| V-101 | | N16-T-56840-60 | | |
| V-102 | | N16-T-76005 | | |
| V-103 | | N16-T-56203-53 | | |
| V-104 | | N16-T-75814 | | |
| V-109 | | N16-T-75751 | | |
| V-110 | | N16-T-56295 | | |
| W-101 | | N15-C-12211-750 | | |
| W-102 | | N16-C-11944-1644 | | |
| W-104 | | | | |
| W-105 | | | | |
| W-106 | | N16-C-11923-1751 | | |
| W-107 | | | | |
| XE-102 | | | | |
| XE-103 | | N17-L-51712-9721 | | |
| XF-101 | | N17-F-74266-9231 | | |
| XV-101 | | N16-S-62603-6702 | | |
| XV-104 | | N16-S-64063-6713 | | |
| CN-179/URM-26A | | N16-A-96079-3426 | | |
| MX-1289/URM-26A | | N16-A-22081-1024 | | |

TABLE 8-3. STOCK NUMBER CROSS REFERENCE

| FEDERAL STOCK NUMBER | KEY DESIG. | STANDARD NAVY STOCK NUMBER | KEY DESIG. |
|----------------------------|-----------------|----------------------------|------------|
| | | N16-C-73148-1721 | L-127 |
| | | N16-C-73197-8563 | L-113 |
| | | N16-C-73273-1278 | L-105 |
| | | N16-C-73539-5771 | L-132 |
| | | N16-C-73586-6725 | L-126 |
| | | N16-C-75168-8496 | L-102 |
| | | N16-C-75794-7249 | L-104 |
| | | N16-C-76285-7439 | L-103 |
| | | N16-C-99999-746 | C-123 |
| | | N16-C-600001-392 | O-119 |
| | | N16-D-46357-2055 | I-102 |
| | | N16-D-200001-121 | O-107 |
| | | N16-D-200001-132 | O-121 |
| | | N16-D-900411-122 | O-102 |
| | | N16-E-300066-664 | O-118 |
| | | N16-G-67501-1022 | L-129 |
| | | N16-G-67501-1023 | L-128 |
| | | N16-G-67501-1024 | L-130 |
| | | N16-G-67501-1025 | L-131 |
| | | N16-G-500001-465 | O-104 |
| | | N16-H-150001-333 | H-111 |
| | | N16-H-161001-181 | H-108 |
| | | N16-J-300001-0150 | O-126 |
| | | N16-K-700065-542 | E-106 |
| | | N16-K-700099-201 | E-107 |
| | | N16-K-700337-327 | E-108 |
| | | N16-M-16001-1008 | I-105 |
| | | N16-M-60918-1606 | H-103 |
| | | N16-M-61584-7501 | O-108 |
| | | N16-N-88601-1055 | H-116 |
| | | N16-P-403561-143 | H-107 |
| | | N16-P-403561-146 | H-106 |
| | | N16-P-460523-525 | E-104 |
| | | N16-R-29315-8801 | L-101 |
| | | N16-R-49238-811 | R-144 |
| | | N16-R-49364-811 | R-143 |
| | | N16-R-49426-433 | R-176 |
| | | N16-R-49444-431 | R-148 |
| | | N16-R-49462-438 | R-302 |
| | | N16-R-49498-431 | R-150 |
| | | N16-R-49580-811 | R-104 |
| | | N16-R-49660-438 | R-301 |
| | | N16-R-49786-431 | R-117 |
| STANDARD NAVY STOCK NUMBER | KEY DESIG. | | |
| G41-W-2444 | H-122 | | |
| G41-W-2445-5 | H-123 | | |
| G41-W-2446 | H-124 | | |
| G41-W-2449 | H-125 | | |
| GM17-L-6305-46 | E-101 | | |
| GM17-L-6811 | E-103 | | |
| N15-C-12211-750 | W-101 | | |
| N16-A-22081-1024 | MX-1289/URM-26A | | |
| N16-A-96079-3426 | CN-179/URM-26A | | |
| N16-A-700001-261 | O-115 | | |
| N16-C-10881-1231 | O-101 | | |
| N16-C-11923-1751 | W-106 | | |
| N16-C-11944-1644 | W-102 | | |
| N16-C-17091-7990 | C-117 | | |
| N16-C-18631-1621 | C-131 | | |
| N16-C-18631-1983 | C-113 | | |
| N16-C-19111-1118 | C-112 | | |
| N16-C-19111-1251 | C-116 | | |
| N16-C-31080-2214 | C-110 | | |
| N16-C-33622-5588 | C-103 | | |
| N16-C-33627-7705 | C-105 | | |
| N16-C-46347-3081 | C-106 | | |
| N16-C-47297-3175 | C-102 | | |
| N16-C-49197-3878 | C-109 | | |
| N16-C-51515-5280 | C-101 | | |
| N16-C-66269-4999 | C-128 | | |

TABLE 8-3. STOCK NUMBER CROSS REFERENCE—Continued

| STANDARD NAVY STOCK NUMBER | KEY DESIG. | STANDARD NAVY STOCK NUMBER | KEY DESIG. |
|-------------------------------|---------------|-------------------------------|---------------|
| N16-R-49922-811 | R-140 | N16-T-56840-60 | V-101 |
| N16-R-50130-0469 | R-138 | N16-T-75751 | V-109 |
| N16-R-50165-811 | R-115 | N16-T-75814 | V-104 |
| N16-R-50282-811 | R-114 | N16-T-76005 | V-102 |
| N16-R-50372-811 | R-152 | N17-B-77413-5746 | TB-105 |
| N16-R-50480-811 | R-162 | N17-B-77482-9216 | TB-109 |
| N16-R-50633-811 | R-109 | N17-B-77482-9221 | TB-108 |
| N16-R-50714-811 | R-110 | N17-B-78036-6751 | TB-104 |
| N16-R-50822-811 | R-108 | N17-B-78113-7026 | TB-102 |
| N16-R-50975-811 | R-116 | N17-B-78227-3251 | TB-103 |
| N16-R-51326-811 | R-119 | N17-B-78283-1071 | TB-101 |
| N16-R-54528-241 | R-141 | N17-B-775001-212 | H-109 |
| N16-R-54546-181 | R-135 | N17-C-71408-5333 | J-201 |
| N16-R-54636-241 | R-113 | N17-C-71408-9255 | P-103 |
| N16-R-54834-181 | R-105 | N17-C-73108-1259 | J-202 |
| N16-R-54861-241 | R-107 | N17-C-73108-1262 | J-106 |
| N16-R-54924-241 | R-163 | N17-C-73108-1267 | J-104 |
| N16-R-55023-342 | R-103 | N17-C-200964-601 | O-123 |
| N16-R-55235-776 | R-112 | N17-F-16320-25 | F-101 |
| N16-R-55293-181 | R-130 | N17-F-74266-9231 | XF-101 |
| N16-R-66103-9486 | R-160 | N17-G-151841-632 | H-113 |
| N16-R-66397-4791 | R-169 | N17-I-250620-0101 | I-101B |
| N16-R-79098-8629 | R-128 | N17-L-3911-150 | E-102 |
| N16-R-87851-9285 | R-145 | N17-L-51712-9721 | XE-103 |
| N16-R-90298-5400 | R-126 | N17-L-076657-9199 | I-101A |
| N16-R-91291-4930 | R-101 | N17-M-26638-2206 | M-101 |
| N16-R-93601-1046 | R-174 | N17-P-22376-8748 | H-104 |
| N16-R-751251-122 | O-105 | N17-S-46748-7001 | O-109 |
| N16-R-751251-126 | O-116 | N17-S-46768-5558 | O-114 |
| N16-R-751251-127 | O-106 | N17-S-46774-5671 | H-115 |
| N16-R-751251-128 | O-111 | N17-S-46844-9361 | O-120 |
| N16-R-751371-105 | O-113 | N17-S-65044-1516 | S-104 |
| N16-S-34557-8351 | EV-103 | N17-S-72018-7701 | S-103 |
| N16-S-34576-6514 | EV-104 | N17-S-73959-1025 | S-101 |
| N16-S-34607-6039 | EV-101 | N17-T-74265-2930 | T-101 |
| N16-S-62603-6702 | XV-101 | N17-W-237981-130 | R-149 |
| N16-S-64063-6713 | XV-104 | N42-F-3649-702 | H-117 |
| N16-S-117101-810 | I-104 | N42-F-3649-2000 | H-105 |
| N16-S-117102-104 | I-103 | N42-R-2057-4140 | O-112 |
| N16-S-550121-108 | O-110 | N43-S-52829-4800 | H-101 |
| N16-S-685341-114 | O-122 | N43-W-7508-2579 | H-121 |
| N16-T-56203-53 | V-103 | N43-W-22849-7232 | H-118 |
| N16-T-56295 | V-110 | N43-22849-7281 | H-119 |

TABLE 8-3. STOCK NUMBER CROSS REFERENCE—Continued

| SIGNAL CORPS STOCK NUMBER | KEY DESIG. | AIR FORCE STOCK NUMBER | KEY DESIG. |
|------------------------------|---------------|---------------------------|---------------|
| | | | |

TABLE 8-4. LIST OF MANUFACTURERS

| ABBREVIATION | PREFIX | NAME | ADDRESS |
|--------------|--------|---|--|
| AB | CBZ | Allen-Bradley Co. | 136 W. Greenfield Ave. Milwaukee 4, Wisconsin |
| APM | | Automatic & Precision Manufacturing Co. | 252 Hawthorne Avenue Yonkers 5, New York |
| BUS | CFA | Bussman Mfg. Co. | 2538 W. University St. St. Louis 7, Missouri |
| CC | CCC | Continental Carbon, Inc. | 13900 Lorain Avenue Cleveland 11, Ohio |
| CIN | CMG | Cinch Manufacturing Co. | 1026 So. Homan Ave. Chicago 24, Illinois |
| CL | CBN | Centralab Division of Globe Union Corp. | 900 E. Keefe Ave. Milwaukee 1, Wisconsin |
| DLC | | Dial Light Co. of America | 60 Stewart Ave. Brooklyn 37, New York |
| DM | | Harry Davies Molding Co. | 1428 N. Wells Street Chicago 10, Illinois |
| GE | CG | General Electric Co. | 1 River Road Schenectady 5, New York |
| HMC | | Heyman Mfg. Co. | 1000 Michigan Avenue Kenilworth, New Jersey |
| MC | CAGU | Measurements Corp. | Boonton, New Jersey |
| NLC | | National Lockwasher Co. | 40 Hermon Street Newark 5, New Jersey |

INDEX

| SUBJECT | FIGURE OR TABLE | PARAGRAPH | PAGE |
|---|--------------------|-----------|------|
| A | | | |
| Adapter, Test, MX-1289/URM-26A— repair of | | 7-20 | 7-20 |
| Adjustments— | | | |
| initial | 3-3 | | 3-1 |
| output meter zero | 7-3 | | 7-5 |
| % modulation meter zero | 7-5 | | 7-6 |
| plate voltage | 7-2 | | 7-1 |
| preliminary | 4-2 | | 4-1 |
| AF oscillator | 2-5 | | 2-5 |
| Attenuator, Fixed, CN-179/URM-26A repair of | | 7-19 | 7-18 |
| Attenuator, RF Output— replacing components of | | 7-10 | 7-14 |
| B | | | |
| Block diagram, RF Signal Generator SG-45A/URM-26 | 2-1 | | 2-0 |
| Bolometer— | | | |
| assembly, replacement of | | 7-8 | 7-12 |
| filter, repair of | | 7-15 | 7-17 |
| C | | | |
| Cable, attenuator drive, replacing | | 7-13 | 7-16 |
| Cable, method of assembling | 7-19 | | 7-21 |
| Calibration— | | | |
| frequency | | 7-12 | 7-15 |
| frequency, checking | | 7-6 | 7-8 |
| output meter | | 7-4 | 7-5 |
| % modulation | | 7-5 | 7-6 |
| Capacitor, tuning, replacing | | 7-11 | 7-15 |
| Check chart, routine maintenance | 6-1 | | 6-1 |
| Circuits, general description of— | | 2-1 | 2-0 |
| AF oscillator | | 2-1c | 2-0 |
| block diagram | 2-1 | | 2-0 |
| modulation, external | | 2-1d | 2-0 |
| modulation, pulse | | 2-1e | 2-0 |
| power supply | | 2-1f | 2-0 |
| RF oscillator | | 2-1b | 2-0 |
| Coils— | | | |
| bolometer filter, replacement of | | 7-15 | 7-17 |
| oscillator heater filter, replacement of | | 7-16 | 7-18 |
| plate filter, replacement of | | 7-17 | 7-18 |
| Connections, external— | | | |
| auxiliary equipment | 4-3 | | 4-3 |
| checking frequency calibration | 7-8 | | 7-8 |
| measuring output voltage | 7-7 | | 7-8 |
| receiver measurements | 4-5 | | 4-4 |
| test | 4-2 | | 4-2 |
| Controls, panel, function of | | 4-1 | 4-1 |

| SUBJECT | FIGURE OR TABLE | PARAGRAPH | PAGE |
|---|--------------------|-----------|------|
| Cord CG-409/U (4' 0"), method of assembling | 7-19 | | 7-21 |
| Corrections— | | | |
| pulse output | 4-4 | | 4-3 |
| record of | | | C |
| Coverage, instruction book | | 1-1 | 1-1 |
| D | | | |
| Dial— | | | |
| resetting frequency | | 7-6c | 7-8 |
| E | | | |
| Effective pages, list of | | | A |
| Electron tube complement | 1-3 | | 1-2 |
| Emergency maintenance | | 5-1 | 5-0 |
| Equipment, test | | 7-1b | 7-1 |
| Equipment Supplied | 1-1 | | 1-1 |
| F | | | |
| Filter— | | | |
| bolometer coils, replacement of | | 7-9 | 7-14 |
| bolometer, repair of | | 7-15 | 7-17 |
| heater coil, replacement of | | 7-18 | 7-18 |
| oscillator heater, repair of | | 7-16 | 7-18 |
| oscillator plate supply, repair of | | 7-17 | 7-18 |
| plate coils, replacement of | | 7-9 | 7-14 |
| Fixed attenuator, CN-179/URM-26A— | | | |
| interior and exterior views | 7-18 | | 7-20 |
| repair of | | 7-19 | 7-18 |
| use of | 4-2 | | 4-2 |
| Frequency— | | | |
| calibration | | 7-12 | 7-15 |
| checking | | 7-6 | 7-8 |
| Frequency range | | 1-4i | 1-2 |
| G | | | |
| General description of circuits | | 2-1 | 2-0 |
| Guarantee | | | iv |
| H | | | |
| Heater, standby | | 2-9 | 2-7 |
| I | | | |
| Illustrations, list of | | | ii |
| Installation | | 3-2 | 3-1 |
| Installation record | | | iv |
| L | | | |
| Lamp complement | 1-4 | | 1-3 |
| List of effective pages | | | A |
| List of equipment supplied | 1-1 | | 1-1 |
| List of illustrations | | | ii |
| List of maintenance parts | 8-1 | | 8-1 |
| List of manufacturers | 8-4 | | 8-25 |
| List of tables | | | iii |
| List of tubes used | 1-3 | | 1-2 |
| Lubrication | | 6-3 | 6-1 |

| SUBJECT | FIGURE OR TABLE | PARAGRAPH | PAGE |
|--|--------------------|------------------|------|
| M | | | |
| Maintenance— | | | |
| check chart | 6-1 | | 6-1 |
| emergency | | 5-1 | 5-0 |
| parts list | 8-1 | | 8-1 |
| routine | | 6-1 | 6-1 |
| Major unit | | 1-3 | 1-1 |
| Manufacturers, list of | 8-4 | | 8-25 |
| Measurement of— | | | |
| receiver image ratio | | 4-8 | 4-5 |
| receiver selectivity | | 4-6 | 4-4 |
| receiver sensitivity | | 4-5 | 4-4 |
| receiver signal-to-noise ratio | | 4-7 | 4-4 |
| Meter— | | | |
| output calibration | | 7-4 | 7-5 |
| output zero adjustment | | 7-3 | 7-5 |
| % modulation calibration | | 7-5 | 7-6 |
| % modulation zero | | 7-5 | 7-6 |
| Meter balancing circuit, simplified schematic diagram .. | 2-6 | | 2-5 |
| Modulation, external | | 2-7 | 2-7 |
| Modulation frequencies | | 1-4 _p | 1-2 |
| Modulation monitor | | 2-6 _b | 2-6 |
| Modulation, pulse | | 2-8 | 2-7 |
| Modulator, theory of operation | | 2-6 _a | 2-6 |
| Monitor, modulation | | 2-6 _b | 2-6 |
| O | | | |
| Ordering parts | | | v |
| Oscillator coil sub-assembly, replacement of | | 7-7 | 7-10 |
| Oscillator tube, replacement of | | 7-14 | 7-17 |
| Output system | | 2-4 | 2-3 |
| P | | | |
| Panel controls, function of | | 4-1 | 4-1 |
| Power supply, description of | | 2-2 | 2-0 |
| Power supply, source requirements | | 1-4 _r | 1-2 |
| Promulgating letter | | | B |
| Pulse modulation | | 2-8 | 2-7 |
| Pulse output correction | 4-4 | | 4-3 |
| Purpose and basic principles | | 1-2 | 1-1 |
| R | | | |
| Recalibration— | | | |
| frequency | | 7-12 | 7-15 |
| Receiver tests— | | | |
| image ratio | | 4-8 | 4-5 |
| selectivity | | 4-6 | 4-4 |
| sensitivity | | 4-5 | 4-4 |
| signal-to-noise ratio | | 4-7 | 4-4 |
| Record of corrections | | | C |
| Reference data | | 1-4 | 1-1 |
| Removing— | | | |
| attenuator components | | 7-10 | 7-14 |
| bolometer assembly | | 7-8 | 7-12 |
| filter coils | | 7-9 | 7-14 |
| instrument from case | | 7-1 _e | 7-1 |

| SUBJECT | FIGURE OR TABLE | PARAGRAPH | PAGE |
|--|--------------------|-----------|------|
| oscillator coil sub-assembly | | 7-7 | 7-10 |
| oscillator heater coil | | 7-18 | 7-18 |
| oscillator tube | | 7-14 | 7-17 |
| power supply chassis | | 7-1g | 7-1 |
| tuning capacitor | | 7-11 | 7-15 |
| Replacing— | | | |
| attenuator components | | 7-10 | 7-14 |
| bolometer assembly | | 7-8 | 7-12 |
| filter coils | | 7-9 | 7-14 |
| instrument chassis | | 7-1h | 7-1 |
| oscillator coil sub-assembly | | 7-7 | 7-10 |
| oscillator heater coil | | 7-18 | 7-18 |
| oscillator tube | | 7-14 | 7-17 |
| power supply chassis | | 7-1g | 7-1 |
| tuning capacitor | | 7-11 | 7-15 |
| Report of failure | | | v |
| Resistance data— | | | |
| terminal boards | 7-1 | | 7-2 |
| tube sockets | 7-2 | | 7-3 |
| Resuscitation | | | v |
| Retropicalization | | 6-2 | 6-1 |
| RF oscillator | | 2-3 | 2-3 |
| RF oscillator— | | | |
| plate supply filter, repair of | | 7-17 | 7-18 |
| tube heater filter, repair of | | 7-16 | 7-18 |
| tube, replacement of | | 7-14 | 7-17 |
| RF Signal Generator SG-45A/URM-26— | | | |
| AF oscillator, functional schematic diagram | 2-8 | | 2-6 |
| attenuator | 7-13 | | 7-15 |
| block diagram | 2-1 | | 2-0 |
| coil disc assembly | 7-11 | | 7-12 |
| connections for checking frequency calibration | 7-8 | | 7-8 |
| connections for measuring output voltage | 7-7 | | 7-8 |
| external modulation | 4-3 | | 4-3 |
| front panel | 4-1 | | 4-0 |
| interconnection, power supply to oscillator | 7-20 | | 7-26 |
| interior | 2-2 | | 2-1 |
| methods of assembling cord and cables | 7-19 | | 7-21 |
| modulator and modulation monitor | | | |
| functional schematic diagram | 2-9 | | 2-7 |
| oscillator compartment, interior | 7-10 | | 7-11 |
| oscillator compartment, showing bolometer | 7-12 | | 7-13 |
| output system, functional schematic diagram | 2-7 | | 2-5 |
| partial disassembly, front panel | 7-9 | | 7-9 |
| power supply | 7-6 | | 7-7 |
| power supply, functional schematic diagram | 2-3 | | 2-2 |
| rear view | 7-3 | | 7-4 |
| recalibration set-up | 7-15 | | 7-17 |
| RF filters | 7-17 | | 7-19 |
| RF monitor, functional schematic diagram | 2-5 | | 2-4 |
| RF oscillator, functional schematic diagram | 2-4 | | 2-3 |
| schematic diagram | 7-21 | | 7-27 |
| side view | 7-4 | | 7-5 |
| terminal boards, locations of | 7-1 | | 7-2 |
| top view | 7-5 | | 7-6 |
| tube locations | 5-1 | | 5-0 |
| tuning capacitor mounting | 7-14 | | 7-16 |

| SUBJECT | FIGURE OR TABLE | PARAGRAPH | PAGE |
|--|--------------------|-----------|------|
| RF Signal Generator Set AN/URM-26A— | | | |
| complete equipment | 1-1 | | 1-1 |
| cording diagram | 4-2 | | 4-2 |
| dimensional outline | 3-2 | | 3-1 |
| packaging | 3-1 | | 3-0 |
| schematic diagram | 7-21 | | 7-27 |
| Routine maintenance check chart | 6-1 | | 6-1 |
| S | | | |
| Safety notice | | | v |
| Set-up— | | | |
| frequency recalibration | 7-15 | | 7-17 |
| receiver measurements | 4-5 | | 4-4 |
| Shipping data | 1-2 | | 1-2 |
| Stock number cross reference | 8-3 | | 8-22 |
| Stock number identification | 8-2 | | 8-18 |
| T | | | |
| Table of contents | | | i |
| Tables, list of | | | iii |
| Terminal boards, locations of | 7-1 | | 7-2 |
| Test adapter, MX-1289/URM-26A— | | | |
| interior and exterior views | 7-18 | | 7-20 |
| repair of | | 7-20 | 7-20 |
| use of | 4-2 | | 4-2 |
| Test connections | 4-2 | | 4-2 |
| Test Equipment for Maintenance Use | 7-2 | | 7-1 |
| Test points | | 7-1c | 7-1 |
| Trouble shooting | | 7-1 | 7-1 |
| Tubes, characteristics | 7-4 | | 7-22 |
| Tubes, cross reference | 1-5 | | 1-3 |
| Tubes, operating voltages and currents | 7-3 | | 7-22 |
| Tuning capacitor— | | | |
| replacing | | 7-11 | 7-15 |
| U | | | |
| Unpacking | | 3-1 | 3-1 |
| V | | | |
| Voltage data— | | | |
| terminal boards | 7-1 | | 7-2 |
| tube sockets | 7-2 | | 7-3 |
| W | | | |
| Winding data | 7-5 | | 7-23 |
| Wiring Diagram, Interconnection | 7-20 | | 7-26 |