

**TECHNICAL MANUAL**

**FOR**

**ANTENNA COUPLER GROUP**

**AN/URA-38**

Each transmittal of this document outside the agencies of the U.S. Government must have prior approval of the Naval Electronics Systems Command.

**PUBLISHED BY DIRECTION OF COMMANDER, NAVAL ELECTRONIC SYSTEMS COMMAND**

---

**PUBLICATION: 1 FEBRUARY 1971**  
**CHANGE 3: 27 AUGUST 1973**

## LIST OF EFFECTIVE PAGES

PAGE NUMBERS	CHANGE IN EFFECT	PAGE NUMBER	CHANGE IN EFFECT
Title Page	Change 3	4-29 Thru 4-33	Change 3
ii	Change 3	4-34 Thru 4-35	Original
iii Thru v	Original	4-36	Change 3
vi Thru vii	Change 2	4-37 Thru 4-42	Original
viii	Original	5-1	Original
ix	Change 3	5-2	Change 3
1-0	Original	5-3 Thru 5-4	Change 2
1-1	Change 3	5-5 Thru 5-19	Original
1-2	Original	5-20 Thru 5-21	Change 2
1-3	Change 3	5-22 Thru 5-24	Original
1-4 Thru 1-7	Original	5-25 Thru 5-26	Change 3
1-8	Change 2	5-27 Thru 5-36	Original
1-9 Thru 1-10	Change 3	5-37/5-38	Change 3
2-1 Thru 2-8	Original	5-39 Thru 5-42	Original
2-9	Change 3	6-1 Thru 6-2	Original
2-10 Thru 2-11	Original	6-3 Thru 6-6	Change 3
2-12 Thru 2-14	Change 3	6-7 Thru 6-8	Original
3-1	Original	6-9 Thru 6-10	Change 3
3-2	Change 3	6-11 Thru 6-14	Original
3-3	Original	6-15	Change 3
3-4 Thru 3-5	Change 3	6-16 Thru 6-17	Original
3-6 Thru 3-10	Original	6-18	Change 3
4-1 Thru 4-6	Original	6-19 Thru 6-21	Original
4-7	Change 3	6-22	Change 3
4-8	Original	6-23 Thru 6-25	Original
4-9	Change 3	6-26 Thru 6-27	Change 3
4-10 Thru 4-28	Original		

RF COMMUNICATIONS, INC.

1680 UNIVERSITY AVENUE  
ROCHESTER, NEW YORKCONTRACT NO.  
NObsr 93367

Errors found in this publication (other than obvious typographical errors) should be reported. Such report should include the complete title of the publication and the publication number. Identify the page and line or figure and location of error, and forward to the

COMMANDER NAVAL ELECTRONIC SYSTEMS COMMAND  
WASHINGTON, D.C. 20360

## Change 3

Change 3 to Technical Manual for  
Antenna Coupler Group AN/URA-38  
NAVSHIPS 0967-204-0010

The ordering number for this change is NAVELEX 0967-204-0014.

This change revises the manual to reflect the equipment changes made by Field Change 5. The purpose of this field change is to improve reliability of the blower motor and pressure switch.

Maintenance support activities shall make this correction in the Technical Manual immediately, but shall keep the superceded data intact for the support of equipment which has not been modified.

Holders of equipment shall not make this correction in the manual until the field change has been accomplished.

Make the following changes to the Technical Manual NAVSHIPS 0967-204-0010.

1. Remove Title page/ii and insert Change 3 Title page/ii.
2. Remove Original page ix and insert Change 3 page ix.
3. Remove Original page 1-1 and insert Change 3 page 1-1.
4. Remove Original page 1-3 and insert Change 3 page 1-3.
5. Add Change 3 page 1-9/1-10.
6. Remove Original page 2-9 and insert Change 3 page 2-9.
7. Remove Original page 2-12 and insert Change 3 page 2-12.
8. Remove Original page 2-13/2-14 and insert Change 3 page 2-13/2-14.
9. Remove Original page 3-2 and insert Change 3 page 3-2.
10. Remove Original page 3-4 and insert Change 3 page 3-4.
11. Remove Original page 3-5 and insert Change 3 page 3-5.
12. Remove Original page 4-7 and insert Change 3 page 4-7.
13. Remove Original page 4-9 and insert Change 3 page 4-9.
14. Remove Original page 4-29/4-30 and insert Change 3 page 4-29/4-30.
15. Remove Original page 4-31/4-32 and insert Change 3 page 4-31/4-32.
16. Remove Original page 4-33 and insert Change 3 page 4-33.
17. Remove Original page 4-36 and insert Change 3 page 4-36.
18. Remove Change 1 page 5-2 and insert Change 3 page 5-2.
19. Remove Original page 5-25/5-26 and insert Change 3 page 5-25/5-26.
20. Remove Original page 5-29 and insert Change 3 page 5-29.
21. Remove Original page 5-31/5-32 and insert Change 3 page 5-31/5-32.
22. Remove Original page 5-37/5-38 and insert Change 3 page 5-37/5-38.
23. Remove Change 2 page 6-3/6-4 and insert Change 3 page 6-3/6-4.
24. Remove Change 2 page 6-5/6-6 and insert Change 3 page 6-5/6-6.
25. Remove Original page 6-9/6-10 and insert Change 3 page 6-9/6-10.
26. Remove Original page 6-15 and insert Change 3 page 6-15.
27. Remove Original page 6-18 and insert Change 3 page 6-18.
28. Remove Original page 6-22 and insert Change 3 page 6-22.
29. Remove Change 2 page 6-26 and insert Change 3 page 6-26.
30. Remove Change 1 page 6-27 and insert Change 3 page 6-27.

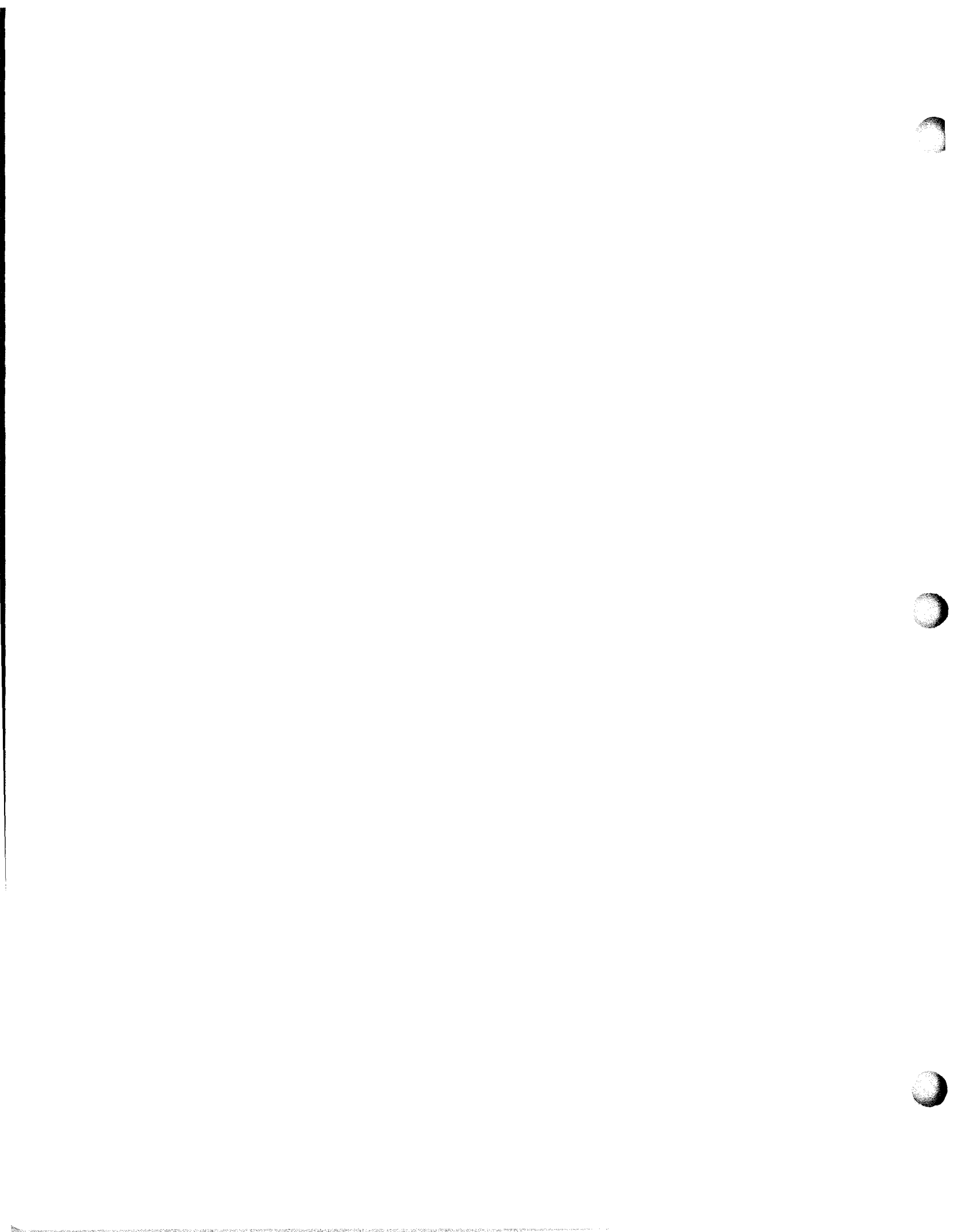



## Change 2

Change 2 to Technical Manual for  
Antenna Coupler Group AN/URA-38  
NAVSHIPS 0967-204-0010  
(Dated 1 Feb 1971)

The ordering number for this change is NAVELEX 0967-204-0012.

This change revises the manual to reflect the equipment changes made by Field Change 4. The purpose of this field change is to improve the CU-938 Antenna Terminal.

Maintenance support activities shall make this correction in the Technical Manual immediately, but shall keep the superceded data intact for the support of equipment which has not been modified.

Holders of equipment shall not make this correction in the manual until the field change has been accomplished.

Make the following changes to the Technical Manual NAVSHIPS 0967-204-0010.

1. Remove title page/ii and insert Change 2 Title page/ii.
2. Remove original page vi and insert Change 2 page vi.
3. Remove original page vii and insert Change 2 page vii.
4. Remove original page 1-8 and insert Change 2 page 1-8.
5. Remove Change 1 page 5-3 and insert Change 2 page 5-3.
6. Remove original page 5-4 and insert Change 2 page 5-4.
7. Remove original page 5-20 and insert Change 2 page 5-20.
8. Remove original page 5-21 and insert Change 2 page 5-21.
9. Remove original page 6-3 and insert Change 2 page 6-3.
10. Remove original page 6-6 and insert Change 2 page 6-6.
11. Remove original page 6-26 and insert Change 2 page 6-26.
12. Insert this instruction sheet behind the front cover.

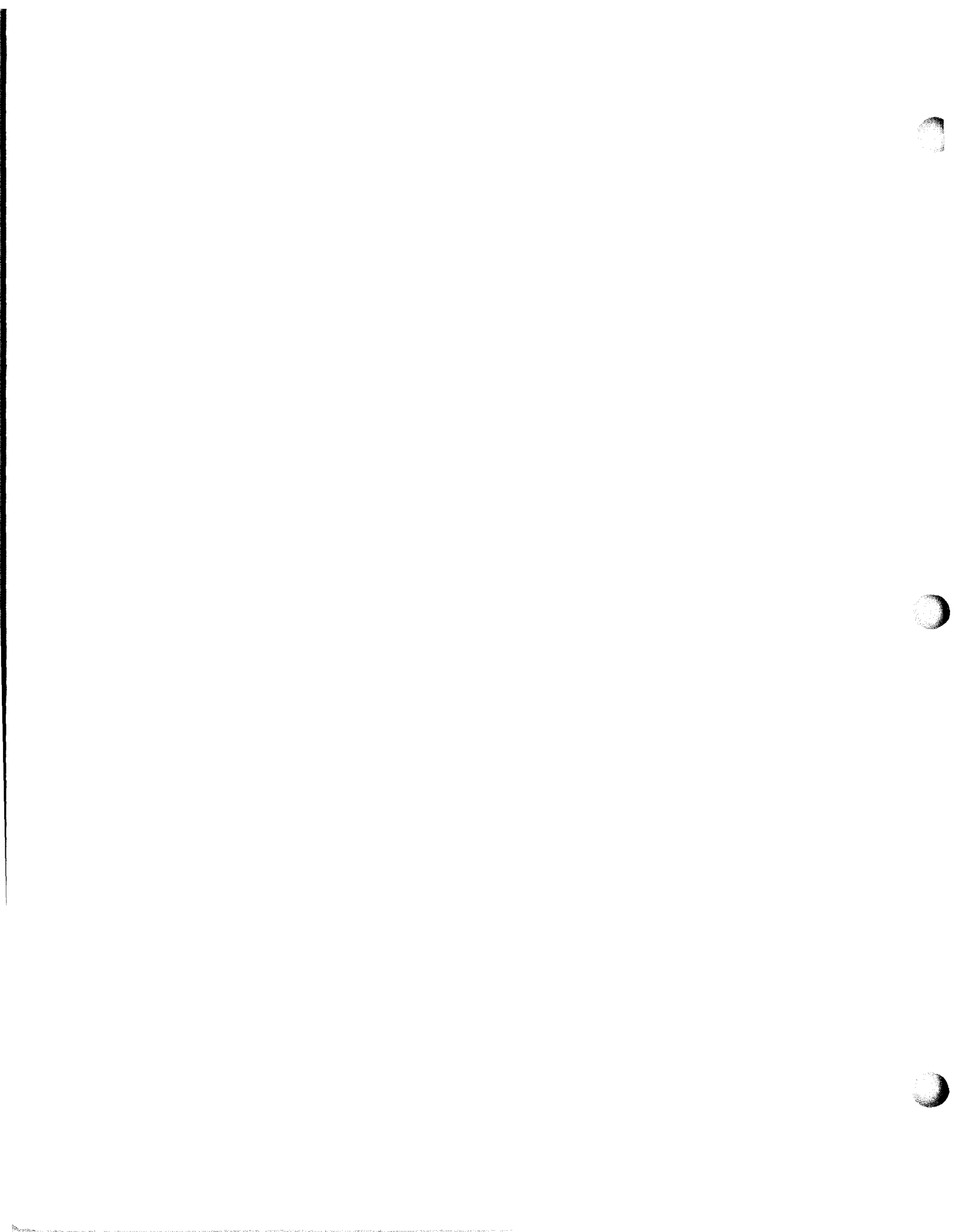

Change 1 to Technical Manual  
for Antenna Coupler Group AN/URA-38  
NAVSHIPS 0967-204-0010

The ordering number for this change is NAVELEX 0967-204-0011

Change 1 corrects errors in the manual published 1 Feb 1971.

Maintenance support activities and holders of equipment will make this change to their manuals immediately upon receipt.

- ✓ 1. Remove Title Page /ii and insert Change 1 Title Page /ii.
- ✓ 2. Remove page 5-1/5-2 and 5-3/5-4 and insert Change 1 page 5-1/5-2 and 5-3/5-4.
- ✓ 3. Remove page 5-25/5-26 and insert page 5-25/Change 1, 5-26.
- ✓ 4. Insert page 6-27.
- ✓ 5. Insert this instruction sheet behind the front cover and rebind manual.

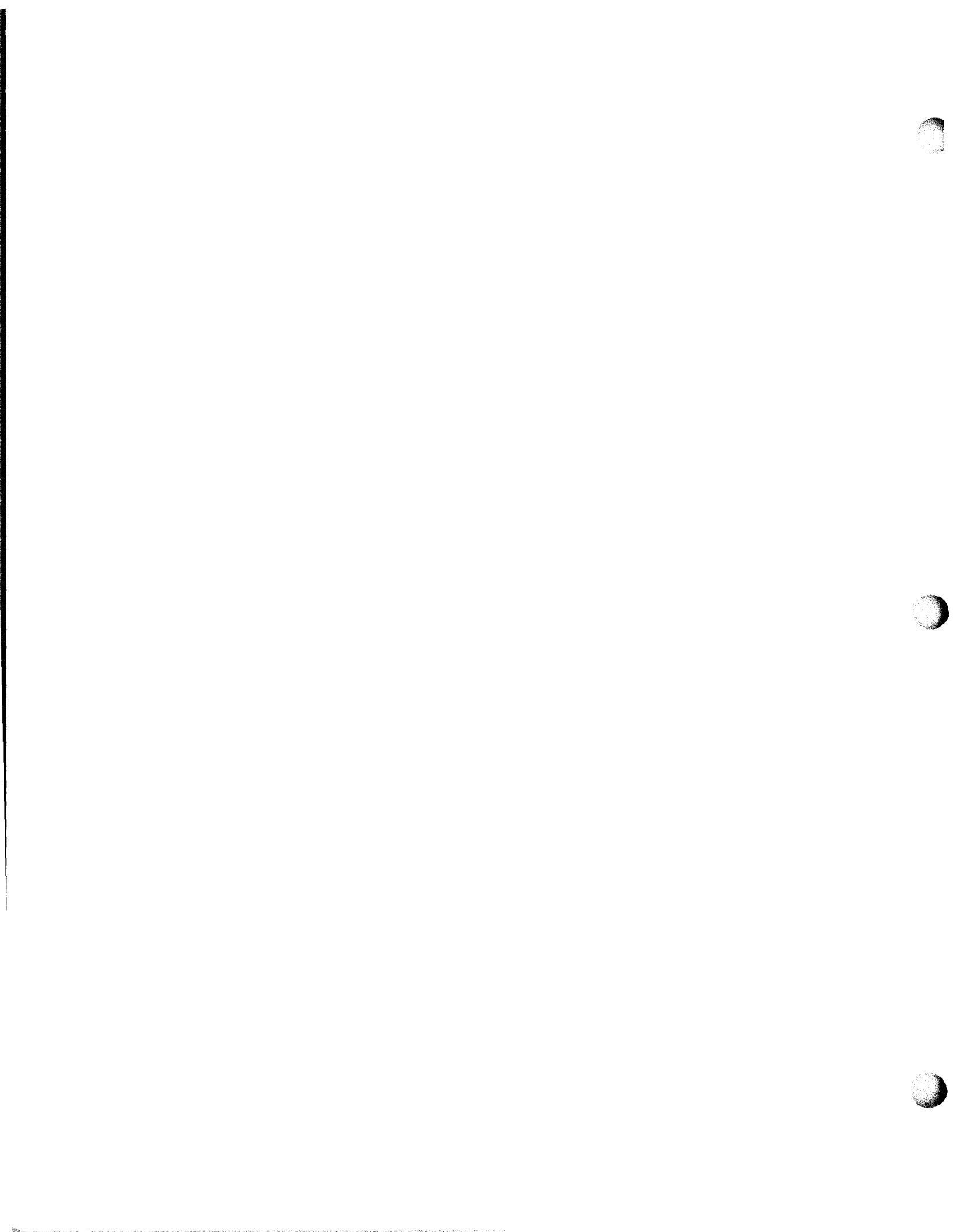

## TABLE OF CONTENTS

Section		Page
1	GENERAL INFORMATION .....	1-1
	1-1. Scope .....	1-1
	1-4. Description .....	1-1
	1-5. General .....	1-1
	1-7. Antenna Coupler CU-938/URA-38 .....	1-1
	1-10. Antenna Coupler Control C-3698/URA-38 .....	1-2
	1-13. Reference Data .....	1-2
	1-15. Equipment Supplied .....	1-3
	1-17. Typical Equipment, Publications, and Cables Required but not Supplied. ....	1-3
	1-19. Preparation for Reshipment .....	1-3
	1-21. Factory or Field Changes .....	1-3
	1-23. Equipment Similarities .....	1-3
2	INSTALLATION .....	2-1
	2-1. Unpacking and Handling .....	2-1
	2-3. Power Requirements .....	2-1
	2-5. Site Selection .....	2-1
	2-8. Installation Requirements .....	2-1
	2-9. Considerations .....	2-1
	2-11. Antenna Coupler CU-938/URA-38 .....	2-5
	2-13. Antenna Coupler Control C-3698/URA-38 .....	2-6
	2-15. Cable Assemblies .....	2-6
	2-17. Interlock Information .....	2-10
	2-19. Interconnections .....	2-10
	2-21. Inspection and Adjustment .....	2-10
	2-22. Inspection .....	2-10
	2-24. Adjustment .....	2-10
	2-26. Performance Checks .....	2-10
	2-28. Interference Reduction .....	2-10
	2-30. Pressurization .....	2-12
3	OPERATION .....	3-1
	3-1. Functional Operation .....	3-1
	3-2. General .....	3-1
	3-5. Operation .....	3-1
	3-6. Automatic .....	3-1
	3-7. Manual .....	3-1
	3-8. Semi-Automatic .....	3-2
	3-9. Silent .....	3-2
	3-10. Overload Protection .....	3-2
	3-11. Operating Procedures .....	3-2
	3-12. Description of Operating Controls and Indicators .....	3-2
	3-14. Automatic Operation .....	3-4
	3-16. Semi-Automatic Operation .....	3-5

## TABLE OF CONTENTS (Cont)

Section	Page
3-18. Manual Operation . . . . .	3-6
3-20. Silent Operation . . . . .	3-8
3-22. Emergency Operation . . . . .	3-9
3-26. Operator's Maintenance . . . . .	3-9
3-27. Operating Checks . . . . .	3-9
3-29. Preventive Maintenance . . . . .	3-10
3-31. Emergency Maintenance . . . . .	3-10
 4 TROUBLESHOOTING . . . . .	 4-1
4-1. Logical Troubleshooting . . . . .	4-1
4-3. Symptom Recognition . . . . .	4-1
4-5. Symptom Elaboration . . . . .	4-1
4-7. Listing Probable Faulty Function . . . . .	4-1
4-9. Localizing the Faulty Function . . . . .	4-1
4-12. Localizing Trouble to the Circuit . . . . .	4-2
4-14. Failure Analysis . . . . .	4-2
4-16. Functional Description . . . . .	4-2
4-17. General . . . . .	4-2
4-21. Automatic Tuning Cycle . . . . .	4-5
4-26. Manual Tuning Cycle . . . . .	4-6
4-28. Silent Tuning Cycle . . . . .	4-6
4-30. Power Supply and Cooling . . . . .	4-7
4-32. Test Data . . . . .	4-7
4-34. Detailed Descriptions . . . . .	4-8
4-35. Matching Network . . . . .	4-8
4-36. General . . . . .	4-8
4-37. Circuit Description . . . . .	4-8
4-39. Test Data . . . . .	4-9
4-40. $\emptyset$ Discriminator . . . . .	4-9
4-41. General . . . . .	4-9
4-42. Circuit Description . . . . .	4-9
4-44. Test Data . . . . .	4-11
4-45. R Discriminator . . . . .	4-11
4-46. General . . . . .	4-11
4-47. Circuit Description . . . . .	4-11
4-49. Forcing . . . . .	4-13
4-50. Test Data . . . . .	4-13
4-51. Servo Amplifier . . . . .	4-13
4-52. General . . . . .	4-13
4-53. Circuit Description . . . . .	4-13
4-58. Test Data . . . . .	4-15
4-59. Motor Control Circuit . . . . .	4-16
4-60. General . . . . .	4-16
4-61. Circuit Description . . . . .	4-16
4-64. Test Data . . . . .	4-18
4-65. C Servo Loop Switching and Metering . . . . .	4-18
4-66. General . . . . .	4-18
4-67. Automatic Operation . . . . .	4-18
4-68. Silent Operation . . . . .	4-18
4-69. Manual Operation . . . . .	4-20

## TABLE OF CONTENTS (Cont)

Section		Page
4-70.	L Servo Loop Switching and Metering . . . . .	4-20
4-71.	General . . . . .	4-20
4-72.	Logic Circuits . . . . .	4-22
4-73.	General . . . . .	4-22
4-74.	Home Logic Circuit Description . . . . .	4-22
4-75.	Motor-On Logic Circuit Description . . . . .	4-22
4-78.	Brake Logic Circuit Description . . . . .	4-26
4-80.	Tune Logic Circuit Description . . . . .	4-26
4-84.	Keying Logic Circuit Description . . . . .	4-29
4-88.	Ready Light Logic Circuit Description . . . . .	4-31
4-91.	Logic Test Data . . . . .	4-31
4-93.	Surveillance Disable . . . . .	4-31
4-94	General . . . . .	4-31
4-95	Circuit Description . . . . .	4-33
4-96	Test Data . . . . .	4-33
4-97	Power Supply . . . . .	4-33
4-98	General . . . . .	4-33
4-99	Circuit Description . . . . .	4-33
4-101	Test Data . . . . .	4-35
4-102	Heat Exchanger . . . . .	4-35
4-105	System Troubleshooting . . . . .	4-35
5	MAINTENANCE . . . . .	5-1
5-1	Failure, and Performance and Operation Reports . . . . .	5-1
5-3	Tuning and Adjustment . . . . .	5-1
5-4	Discriminator . . . . .	5-1
5-5	General . . . . .	5-1
5-6	Test Equipment and Special Tools . . . . .	5-1
5-7	Test Setup . . . . .	5-2
5-8	Control Settings . . . . .	5-2
5-9	Instructions . . . . .	5-2
5-10	Servo Amplifiers . . . . .	5-3
5-11	General . . . . .	5-3
5-12	Test Equipment . . . . .	5-3
5-13	Special Fixture . . . . .	5-3
5-14	Control Settings . . . . .	5-3
5-15	Test Setup . . . . .	5-4
5-16	Instructions . . . . .	5-4
5-17	Repair . . . . .	5-5
5-18	Antenna Coupler Control C-3698/URA-38 . . . . .	5-5
5-19	General . . . . .	5-5
5-20	General PCB Parts Replacement Techniques . . . . .	5-5
5-21	Antenna Coupler CU-938/URA-38 . . . . .	5-6
5-22	General . . . . .	5-6
5-23	Removal of Chassis from Case . . . . .	5-7
5-24	Element Position Potentiometer Replacement . . . . .	5-7
5-25	Servo Motor Replacement . . . . .	5-8
5-26	Gear Drive Assembly Component Replacement . . . . .	5-9
5-27	End Stop Switch Replacement . . . . .	5-15

TABLE OF CONTENTS (Cont)

Section		Page
5-28	Damping Relays Replacement . . . . .	5-16
5-29	Variable Capacitor Replacement . . . . .	5-17
5-30	Variable Inductor Replacement . . . . .	5-18
5-31	Antenna Insulator (1A1E1) Material . . . . .	5-20
5-33	Test Cable Fabrication . . . . .	5-21
5-35	RF Load Simulator Fabrication . . . . .	5-21
5-37	Quick Release Plunger Adjustment Tool Fabrication . . . . .	5-21
5-39	Transistor Voltage Measurements . . . . .	5-21
6	PARTS LIST . . . . .	6-1
6-1	Reference Designations . . . . .	6-1
6-3	Reference Designation Prefix . . . . .	6-1
6-5	List of Units . . . . .	6-2
6-7	Maintenance Parts List . . . . .	6-2
6-10	List of Manufacturers . . . . .	6-2



## LIST OF ILLUSTRATIONS

Figure		Page
1-1	Typical Relationship of Units . . . . .	1-0
2-1	Antenna Coupler Control AN/URA-38, Outline Drawing . . . . .	2-3
2-2	Rack Mounting Bracket, Fabrication Diagram . . . . .	2-7
2-3	Interlock Information Diagram . . . . .	2-11
2-4	Antenna Coupler Group AN/URA-38, Interconnection Diagram . . . . .	2-12
3-1	Antenna Coupler Control C-3698/URA-38, Operating Controls and Indicators . . . . .	3-2
4-1	Antenna Coupler Group AN/URA-38, Functional Block Diagram . . . . .	4-3
4-2	Matching Network, Simplified Schematic Diagram . . . . .	4-8
4-3	$\emptyset$ Discriminator, Simplified Schematic Diagram . . . . .	4-10
4-4	R Discriminator, Simplified Schematic Diagram . . . . .	4-12
4-5	Servo Amplifier, Simplified Schematic Diagram . . . . .	4-14
4-6	Motor Control, Simplified Schematic Diagram . . . . .	4-17
4-7	C Servo Loop, Simplified Switching and Metering Diagram . . . . .	4-19
4-8	L Servo Loop, Simplified Switching and Metering Diagram . . . . .	4-21
4-9	Antenna Coupler Group AN/URA-38, Automatic Tuning Sequence Diagram . . . . .	4-23
4-10	Home Logic, Simplified Schematic Diagram . . . . .	4-24
4-11	Motor-On Logic, Simplified Schematic Diagram . . . . .	4-25
4-12	Brake Logic, Simplified Schematic Diagram . . . . .	4-27
4-13	Tune Logic, Simplified Schematic Diagram . . . . .	4-28
4-14	Keying Logic, Simplified Schematic Diagram . . . . .	4-30
4-15	Ready Light Logic, Simplified Schematic Diagram . . . . .	4-32
4-16	Surveillance Disable, Simplified Schematic Diagram . . . . .	4-32
4-17	Power Supply, Simplified Schematic Diagram . . . . .	4-34
4-18	Heat Exchanger . . . . .	4-36
4-19	Antenna Coupler Group AN/URA-38, Logic and Power Supply Servicing Block Diagram . . . . .	4-39
4-20	Antenna Coupler Group AN/URA-38, Servo Loops and Matching Network, Servicing Block Diagram . . . . .	4-41
5-1	Test Set, Antenna Alignment (TS-3228/URA-38)	5-4
5-2	Gear Drive Assembly Fixtures and Jigs, Fabrication Diagram . . . . .	5-10
5-3	Antenna Coupler CU-938/URA-38, Case, Component Locations . . . . .	5-25
5-4	Antenna Coupler CU-938/URA-38, Chassis, Component Locations . . . . .	5-26
5-5	Discriminator Assembly 1A2A2, Component and Test Point Locations . . . . .	5-26
5-6	Gear Drive Assemblies 1A2A1 and 1A2A3, Component Locations . . . . .	5-27
5-7	Inductor Assembly 1A2L1, Component Locations . . . . .	5-29
5-8	Antenna Coupler Control C-3698/URA-38, Chassis, Component Locations . . . . .	5-29
5-9	Printed Circuit Boards 2A1A1 and 2A1A2, Component and Test Point Locations . . . . .	5-30
5-10	Printed Circuit Board 2A1A3, Component and Test Point Locations . . . . .	5-31
5-11	Printed Circuit Board 2A1A4, Component and Test Point Locations . . . . .	5-32
5-12	Antenna Coupler Control C-3698/URA-38, Case, Component Locations . . . . .	5-33
5-13	Primary Power Distribution Diagram . . . . .	5-34
5-14	RF Load Simulator, Fabrication Diagram . . . . .	5-35
5-15	Antenna Coupler CU-938/URA-38, Schematic Diagram . . . . .	5-37
5-16	Antenna Coupler Control C-3698/URA-38, Schematic Diagram . . . . .	5-39

## LIST OF TABLES

Table		Page
1-1	Antenna Coupler Group AN/URA-38 Equipment Supplied . . . . .	1-4
1-2	Antenna Coupler Group AN/URA-38 Typical Equipment, Publications, and Cables Required but not Supplied . . . . .	1-5
2-1	Cable Types and Terminations . . . . .	2-8
2-2	Cable W1 Pin Connections . . . . .	2-9
2-3	Cable W2 Pin Connections . . . . .	2-9
3-1	Antenna Coupler Control C-3698/URA-38, Operating Controls and Indicators . . . . .	3-3
3-2	Antenna Coupler Group AN/URA-38, Preventive Maintenance Checks . . . . .	3-10
4-1	Troubleshooting . . . . .	4-37
5-1	Torque Requirements for Screws . . . . .	5-6
5-2	Position of Contact Arm of Variable Inductor Rotor . . . . .	5-15
5-3	Transistor DC Voltage Measurements . . . . .	5-22
6-1	List of Units . . . . .	6-2
6-2	Maintenance Parts List . . . . .	6-3
6-3	List of Manufacturers . . . . .	6-21

## MAINTENANCE HINTS AND EIB ARTICLES

Record the EIB number and title of additional articles as they are published.

EIB Number	Title
681	AN/URA-38 Antenna Coupler
785	1. Sealing of pressure switch vent in CU-938
	2. Announcement of availability of Field Change 2
786	APL Correction, Transistors
795	Operational change
<u>802</u>	Correction to Technical Manual ✓
<u>807</u>	Announcement of availability of Field Change 3
812	Correction to Field Change 3
817	Announcement of availability of Field Change 1
819	Correction to Technical Manual ✓
825	Correction to Technical Manual, ordering ✓
834	APL Correction, new tuning coil FSN
837	Correction to Field Change 3 -

## EIB Articles related to Antennas and Antenna Couplers.

785	Whip antennas, corrosion prevention procedures
791	Navy type C-44046 and C-44047 whip antennas
810	Wire rope cleaning and materials, 2 articles
825/830	EIB Index
854	1. Weatherproofing and corrosion prevention of topside hardware.
	2. Correction to EIB 785, whip antennas
	3. Correction to EIB 791, whip antenna parts breakdown

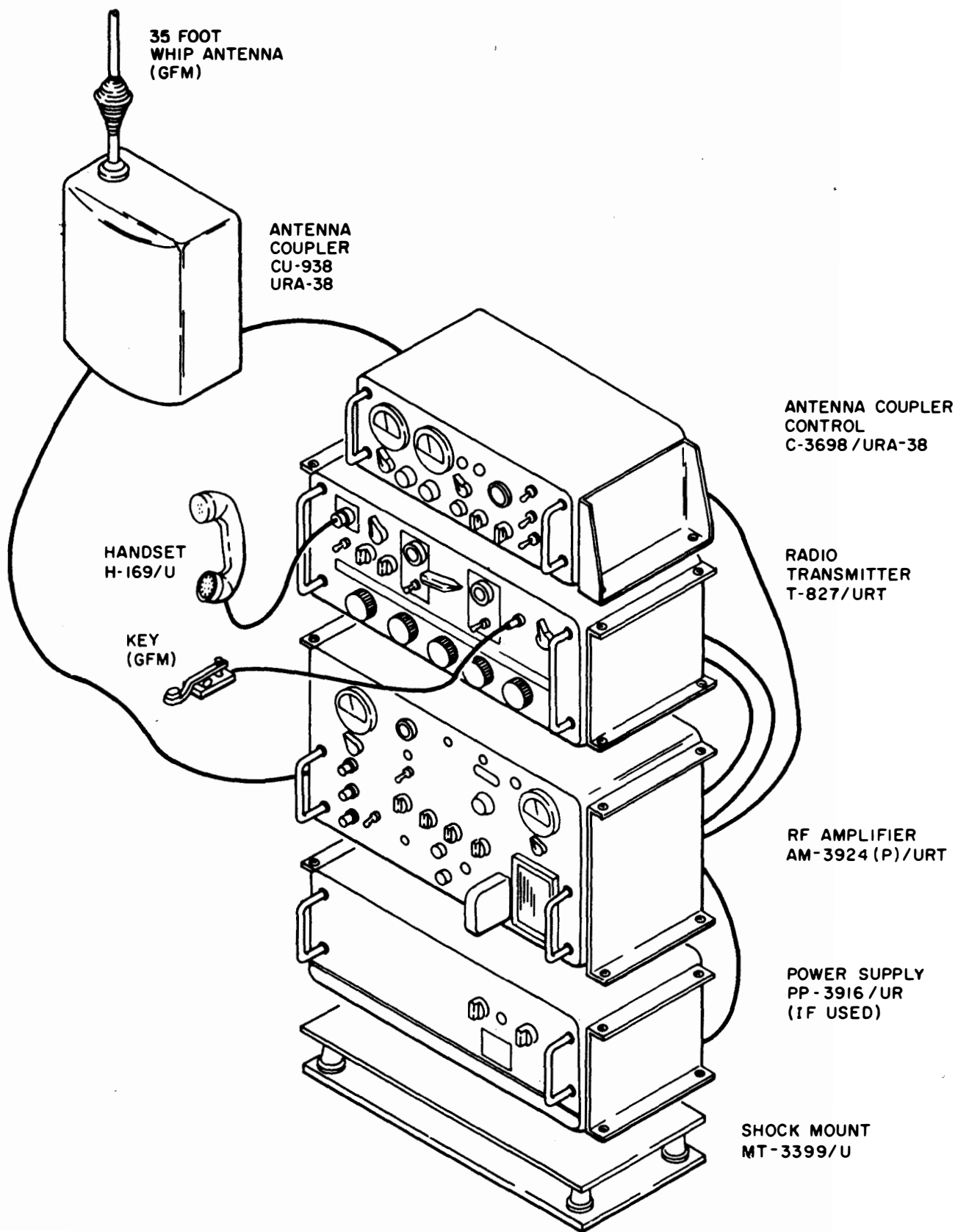

Figure 1-1. Typical Relationships of Units

SECTION 1

GENERAL INFORMATION

1-1. SCOPE.

1-2. This Technical Manual is in effect upon receipt and supersedes NAVSHIPS 96033. Extracts from this publication may be made to facilitate the preparation of other Department of Defense Publications.

1-3. This Technical Manual describes and contains the necessary information to install, operate, repair and maintain Antenna Coupler Group AN/URA-38. Hereinafter, Antenna Coupler Group AN/URA-38 will be referred to as the AN/URA-38.

1-4. DESCRIPTION.

1-5. GENERAL.

1-6. The AN/URA-38 (figure 1-1) is an automatic antenna tuning system intended primarily for surface ship and shore use with Radio Transmitting Set AN/URT-23(V). However, the equipment design includes provisions for manual and semi-automatic tuning, thus making the system readily adaptable for use with other radio transmitters. In addition, the manual tuning capability is useful when a failure occurs in the automatic tuning circuitry. The AN/URA-38 can also be tuned without the use of RF power (silent tuning). This method is useful in installations where radio silence must be maintained except for brief transmission periods. The AN/URA-38 matches the impedance of a 15, 25, 28, or 35 foot whip antenna to the impedance of a 50-ohm transmission line at any frequency in the 2.0 to 30.0 MC range. (The use of a 35 foot whip antenna is preferred.) A 50 to 200 watt CW signal is required for tuning, after which the system is capable of handling 1 KW of average and peak envelope power (PEP). The AN/URA-38 consists of an antenna coupler (normally mounted at the base of the antenna) and an antenna coupler control unit (normally mounted with the associated radio transmitter).

1-7. ANTENNA COUPLER CU-938/URA-38.

1-8. The function of the CU-938/URA-38 (figures 5-3 and 5-4) is to match the impedance of a 15, 25, 28, or 35 foot whip antenna to the impedance of a 50-ohm transmission line, at any frequency in the 2.0 to 30.0 MC range. When operating with the AN/URT-23(V), control signals from the associated antenna coupler control unit automatically tune the CU-938/URA-38 matching network in less than five seconds. During manual and silent operation, tuning is accomplished manually with the controls mounted on the antenna coupler control unit. A low power (not to exceed 200 watts) CW signal is required for tuning. Once tuned, the CU-938/URA-38 is capable of handling 1KW of PEP and average power.

1-9. The CU-938/URA-38 is enclosed in an aluminum, airtight, pressurized case that is approximately 25 inches long, 15 inches wide, and 10 inches high. Access is gained to the chassis by removing the dome-shaped cover from the case. Fins on the bottom of the case carry heat from the unit. Six mounting feet enable the unit to be attached to the mast of a ship at the base of a whip antenna. The CU-938/URA-38 is pressurized to 8 PSIG with dry nitrogen to aid internal heat transfer and prevent corona and arcing. All components of the

CU-938/URA-38 are secured to a chassis which is mounted to the case so that an air duct exists between the chassis plate and the case. An internal fan circulates the nitrogen over and through the heat producing elements and then through the air duct. While passing through the air duct, the nitrogen loses its heat to the bottom of the case. This heat is then transferred to the ambient by convection through the fins on the case and by conduction through the mounting feet.

1-10. ANTENNA COUPLER CONTROL C-3698/URA-38.

1-11. The function of the C-3698/URA-38 (figure 5-8) is to provide the power and control signals required to tune the CU-938/URA-38. The control signals are either automatically produced by the C-3698/URA-38 when a tune cycle is initiated, or manually produced with the front panel controls. All DC operating voltages are produced from a 115 volt, 48 to 63 or 350 to 450 CPS, single phase primary power source. Metering and protection circuits are provided to enable complete control of the CU-938/URA-38 from the remotely positioned C-3698/URA-38.

1-12. The circuits of the C-3698/URA-38 are all mounted on a chassis and panel assembly housed in an aluminum case approximately 5 inches high, 19 inches wide, and 8.5 inches deep. The chassis and panel assembly is attached to the case with a hinge, and secured by four front panel captive screws. Connections between chassis and connectors on the rear of the case are made by a flexible harness assembly and filter box.

1-13. REFERENCE DATA.

1-14. The following data are the electrical characteristics of the AN/URA-38.

- a. Frequency range: 2.0 to 30.0 MC.
- b. RF signal capability: LSB, ISB, USB, CW, FSK and Compatible AM.
- c. RF power capability: 1000 watts average and PEP.
- d. Primary power requirements: 115 volts, 48 to 63 or 350 to 450 CPS, single phase.
- e. VSWR: 1.5:1 Maximum when tuned.
- f. Antenna types: 15, 25, 28, or 35 foot whip. (35 foot preferred.)
- g. Tuning time: Less than 5 seconds in automatic operation.
- h. Modes of operation: Manual, Silent, Automatic.
- i. Temperature limitations: -28 to +65°C for CU-938/URA-38; 0 to +50°C for C-3698/URA-38.
- j. Power consumption: 80 watts maximum (continuous); 130 watts maximum (intermittent for less than 5 seconds).

- k. Input impedance: 50 ohms unbalanced when tuned.
- l. Transistor - Diode Complement:

DIODE	QTY.	TRANSISTOR	QTY.
CU-938/URA-38			
JAN1N914	4		
JAN1N3611	13		
C-3698/URA-38			
JAN1N486B	4	2N2102	2
JAN1N277M	32	JAN2N297A	8
JAN1N753A	4	USN2N1132	4
JAN1N967B	2	JAN2N1309	4
JAN1N3611	18	JAN2N1613	23
		USA 2N2219	2
<b>TOTAL</b>	<b>77</b>	<b>TOTAL</b>	<b>43</b>

1-15. EQUIPMENT SUPPLIED.

1-16. The equipment supplied as a part of the AN/URA-38 is listed in table 1-1.

1-17. TYPICAL EQUIPMENT, PUBLICATIONS, AND CABLES REQUIRED BUT NOT SUPPLIED.

1-18. Typical equipment, publications and cables required but not supplied as a part of the AN/URA-38 are listed in table 1-2.

1-19. PREPARATION FOR RESHIPMENT.

1-20. Each item of the AN/URA-38 is carefully packed to prevent damage during shipment. The units should be repacked carefully if the units are to be reshipped at a later date. If possible use the original shipping containers. Always de-pressurize the CU-938/URA-38 before repacking:

1-21. FACTORY OR FIELD CHANGES.

1-22. There have been five (5) field changes made to the AN/URA-38.(Table 1-4)

1-23. EQUIPMENT SIMILARITIES.

1-24. The AN/URA-38 is similar to the AN/URA-38A. Mechanically, the CU-938A/URA-38 has differences in the case and tuning element gear drives. Electrically, the C-3698A/URA-38 has an additional PC board to provide slow tuning element motor speed for MANUAL operation. The AN/URA-38 and the AN/URA-38A are electrically and mechanically interchangeable and the operating procedures are the same for both.

TABLE 1-1. ANTENNA COUPLER GROUP AN/URA-38 EQUIPMENT SUPPLIED

QTY PER EQUIP	NOMENCLATURE		UNIT NO.	*OVER-ALL DIMENSIONS (IN. )			*VOLUME	*WEIGHT
	NAME	DESIGNATION		HEIGHT	WIDTH	LENGTH		
1	Antenna Coupler	CU-938/URA-38	1	10.62	15.12	25.50	2.37	75.0
1	Antenna Coupler Control	C-3698/URA-38	2	5.23	19.36	8.69	0.51	25.0
1	Interconnecting Cable	W1						
1	Kit, Mating Connectors	10-109628-21P** 10-109628-21S** UG-982/U						
2	Support Clamp	10-36233-243**						
2	Technical Manual	NAVSHIPS 0967-204-0010						
1	Operator's Instruction Chart	NAVSHIPS 0967-204-0020						
1	Performance Standards Sheet	NAVSHIPS 0967-204-0030						
1	Reference Standards Book	NAVSHIPS 0967-204-0040						

\* Includes mounting materials.

\*\* Refer to Bureau of Ships drawing RE49D769.



TABLE 1-2. ANTENNA COUPLER GROUP AN/URA-38 TYPICAL EQUIPMENT, PUBLICATIONS,  
AND CABLES REQUIRED BUT NOT SUPPLIED

QTY PER EQUIP	NOMENCLATURE		REQUIRED USE	ELECTRICAL/ EQUIPMENT CHARACTERISTICS
	NAME	DESIGNATION		
1	Antenna (35-foot whip)		Reception and radiation of RF signals.	
1	Cable Set		Interconnection	Fabricate according to paragraph 2-15.
1	Test Cable		Troubleshooting and maintenance procedures.	Fabricate according to paragraph 5-33.
1	Pressurization Kit	MK-260/U	To pressurize CU-938/URA-38.	
1	Ground strap		Interconnection	
1	Antenna Simulator		Maintenance procedures.	Fabricate according to paragraph 5-35.
1	Electrical Dummy Load	DA-242/U	Troubleshooting and maintenance procedures.	Frequency range: 2 to 30 MC Input impedance: 50 ohms Power input: 0 to 1000 watts
1	Multimeter	AN/PSM-4	Troubleshooting and maintenance procedures.	Voltage range: DC: 0 to 28 AC: 0 to 120 Accuracy: 5%

TABLE 1-2. ANTENNA COUPLER GROUP AN/URA-38 TYPICAL EQUIPMENT, PUBLICATIONS,  
AND CABLES REQUIRED BUT NOT SUPPLIED (Cont)

QTY PER EQUIP	NOMENCLATURE		ELECTRICAL/ EQUIPMENT CHARACTERISTICS
	NAME	DESIGNATION	
1	Wattmeter	AN/URM-120	Power range: 0 to 1KW Frequency range: 2 to 30 MC
1	Set of Rack Mounting Brackets		Fabricate according to paragraph 2-14.
1	Set of Printed Circuit Board Extenders		Fabricate according to paragraph 5-31.
1	Quick Release Plunger Adjustment Tool.		Fabricate according to paragraph 5-37.
1	Gear Drive Assembly Fixture and Jigs		Fabricate according to paragraph 5-26.
1	Set of Torque wrenches, 0-100 in-lbs		
1	Standard Tool Set		
1	Technical Manual for AN/PSM-4		
			Troubleshooting and mainte- nance procedures.
			Installation procedures.
			Troubleshooting and mainte- nance procedures.
			Maintenance procedures.
			Maintenance procedures.
			Assembly procedures.
			Troubleshooting and mainte- nance procedures.
			Troubleshooting and mainte- nance procedures.

TABLE 1-3. FACTORY CHANGES

FACTORY CHANGE NUMBER	FACTORY CHANGE TITLE AND PURPOSE	SERIAL NO. AFFECTED	INDICATION OF ACCOMPLISHMENT
1-AN/URA-38	Addition of capacitor 2A2A1C8 and inductor 2A1L1. To eliminate spurious home signals that result from detecting stray RF.	All except A1 through A130 and A132 through A144.	None Apparent
2-AN/URA-38	Addition of capacitors 2A1A3C11 and 2A1A3C12. To bypass braking transients.	All except A1 through A130 and A132 through A155	None Apparent
3-AN/URA-38	Relocation of 2A1A3C2 and 2A1A3R38. To prevent braking transients from turning on motor-on logic.	All except A1 through A225	None Apparent

TABLE 1-4. FIELD CHANGES

FIELD CHANGE NUMBER	FIELD CHANGE TITLE AND PURPOSE	SERIAL NUMBER AFFECTED	INDICATION OF ACCOMPLISHMENT
1-AN/URA-38	Provides Spark Gap Reliability and Case Pressurization. Improves case pressurization and spark gap material. New gasket added.	All Serial Numbers	Anti-turn plate on connector J-2 and plug of white sealant in vent hole of underpressure switch (1A1S1).
2-AN/URA-38	Provides Power Supply and Motor Brake Circuit Reliability. Improvement of power supply and motor brake circuit reliability. Transient suppression components added.	All Serial Numbers	Presence of circuit breaker and adjacent label indicating "RESET," "ALARM" and "OFF Switch to MANUAL" on front panel.
3-AN/URA-38	Improved Flipper Contacts and Servo Alignment in AN/URA-38. Provides improved tuning coil 1A1L1 Rotor and flipper contacts as well as stabilized servo alignment adjustment and operation.	All Serial Numbers	Presence of trimmer pots on Servo PC Boards 2A1A1, 2A1A2. Vacuum relays on 1A2L1 bracket.
4-AN/URA-38	Ceramic Antenna Insulator. Improve the mechanical and Electrical strength of the antenna insulator.	All Serial Numbers	Presence of ceramic antenna insulator (1A1E1) having Beryllium Oxide marking.

TABLE 1-4. FIELD CHANGES

FIELD CHANGE NUMBER	FIELD CHANGE TITLE AND PURPOSE	SERIAL NUMBER AFFECTED	INDICATION OF ACCOMPLISHMENT
5-AN/URA-38	Improve Reliability of Blower Motor and Pressure Switch. Improved low pressure switch and operates blower with keyline.	All Serial Numbers	Pipe plug in hole of old pressure switch and adjustable pressure relief valve.

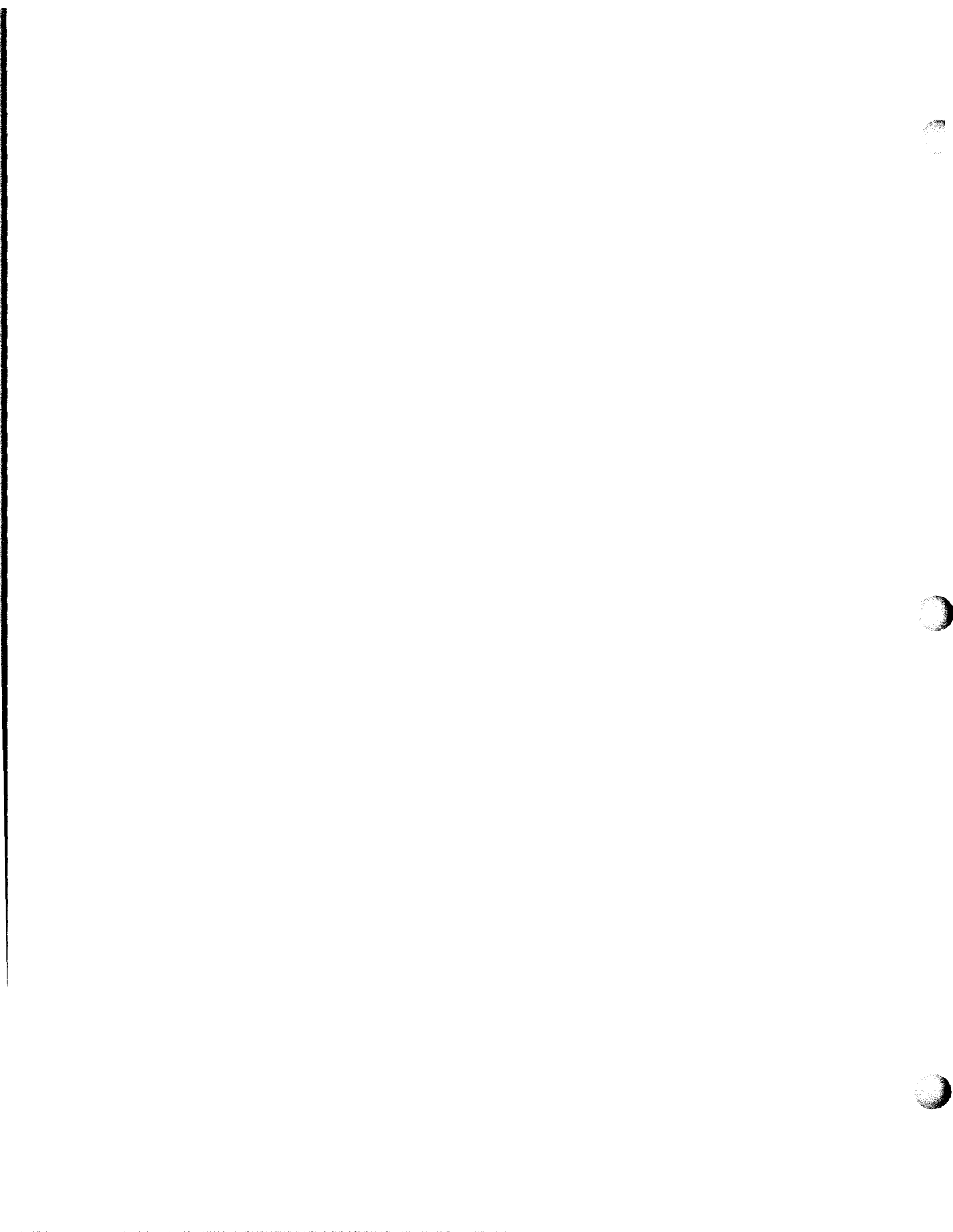

SECTION 2  
INSTALLATION

2-1. UNPACKING AND HANDLING.

2-2. Special procedures need not be followed when unpacking the units of the AN/URA-38. Since the system is made up of accurately calibrated precision units, rough handling should be avoided. Caution should be taken when removing the units from the packing cartons to prevent damage to the controls, indicators, connectors, and valves.

2-3. POWER REQUIREMENTS.

2-4. The AN/URA-38 is designed to operate from a nominal 48 to 63 or 350 to 450 CPS, 115 volt, single phase primary power source. When operating with the AN/URT-23(V), the primary power is supplied through the normal equipment interconnections. When operating with a radio transmitter other than the AN/URT-23(V), primary power must be patched into the cable which normally connects between the AM-3924(P)/URT and C-3698/URA-38, or directly to connector 2A2A1J1 on the C-3698/URA-38. Refer to figure 5-13 for a primary power distribution diagram of the AN/URA-38.

2-5. SITE SELECTION.

2-6. In selecting a shipboard installation site, adequate consideration must be given to space requirements (figure 2-1). When the C-3698/URA-38 is installed with the AN/URT-23(V), the space requirements for that system will satisfy the needs of the C-3698/URA-38. When the C-3698/URA-38 is hard-mounted adjacent to the associated radio transmitter, space should be provided to allow the hinged front panel to be opened for servicing and for cable bends at the rear of the unit. The antenna should be mounted as high above the ship's superstructure as possible. The CU-938/URA-38 must be mounted as close to the antenna base as possible to allow interconnection with a heavy copper conductor not to exceed 36 inches; 12 inches or less is desired. The interconnecting cable between the CU-938/URA-38 and C-3698/URA-38 case should not exceed 500 feet.

2-7. In selecting a shore installation site, similar considerations must be given to space requirements and cable lengths. The antenna should be mounted high enough to clear any surrounding hills, woods, or buildings. In addition, the antenna could be located as far as possible from any high power transmission lines, to prevent interference.

2-8. INSTALLATION REQUIREMENTS.

2-9. CONSIDERATIONS.

2-10. The following considerations should be made when determining the proper location of the AN/URA-38.

- a. Best operating conditions.
- b. Ease of maintenance, adjustment of equipment, and replacement and repair of defective parts or complete units.

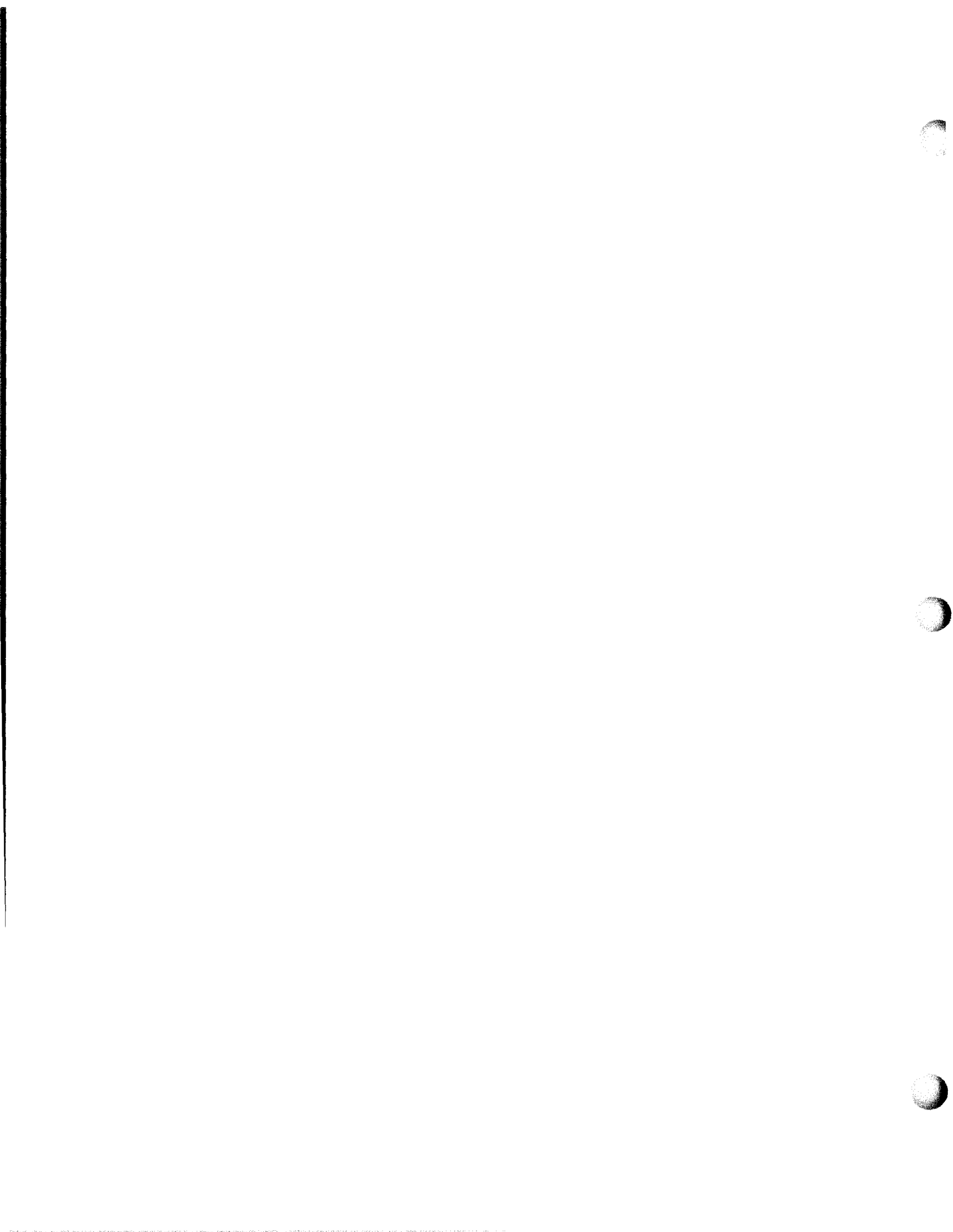



NOTES:

1. The antenna connection is at high voltage and must have minimum clearance of 6 inches in any direction.
2. Dimensions (8" and 18") indicate clearance necessary to remove chassis from their respective cases.

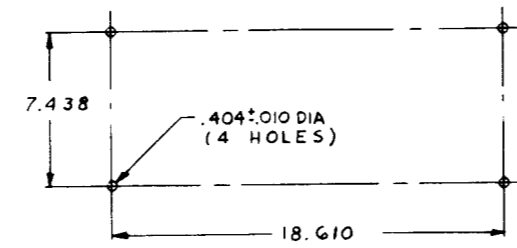

MOUNTING HOLE PATTERN  
FOR COUPLER CONTROL  
C-3698/URA-38

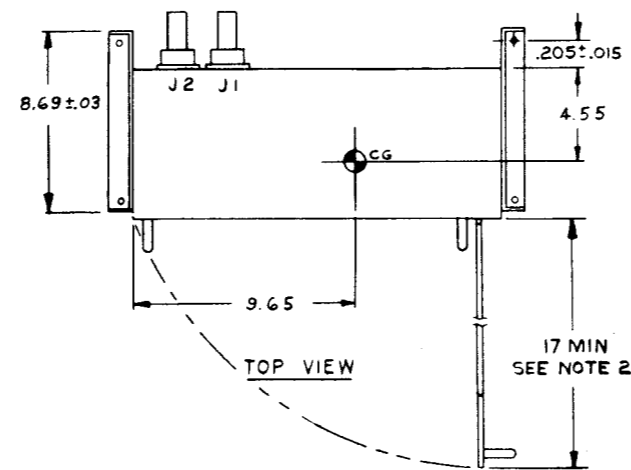

TOP VIEW

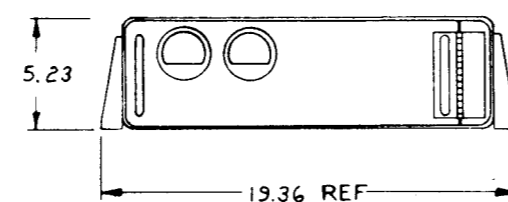

FRONT VIEW

C-3698/URA-38  
CONTROL UNIT  
(WEIGHT 23 LB.)

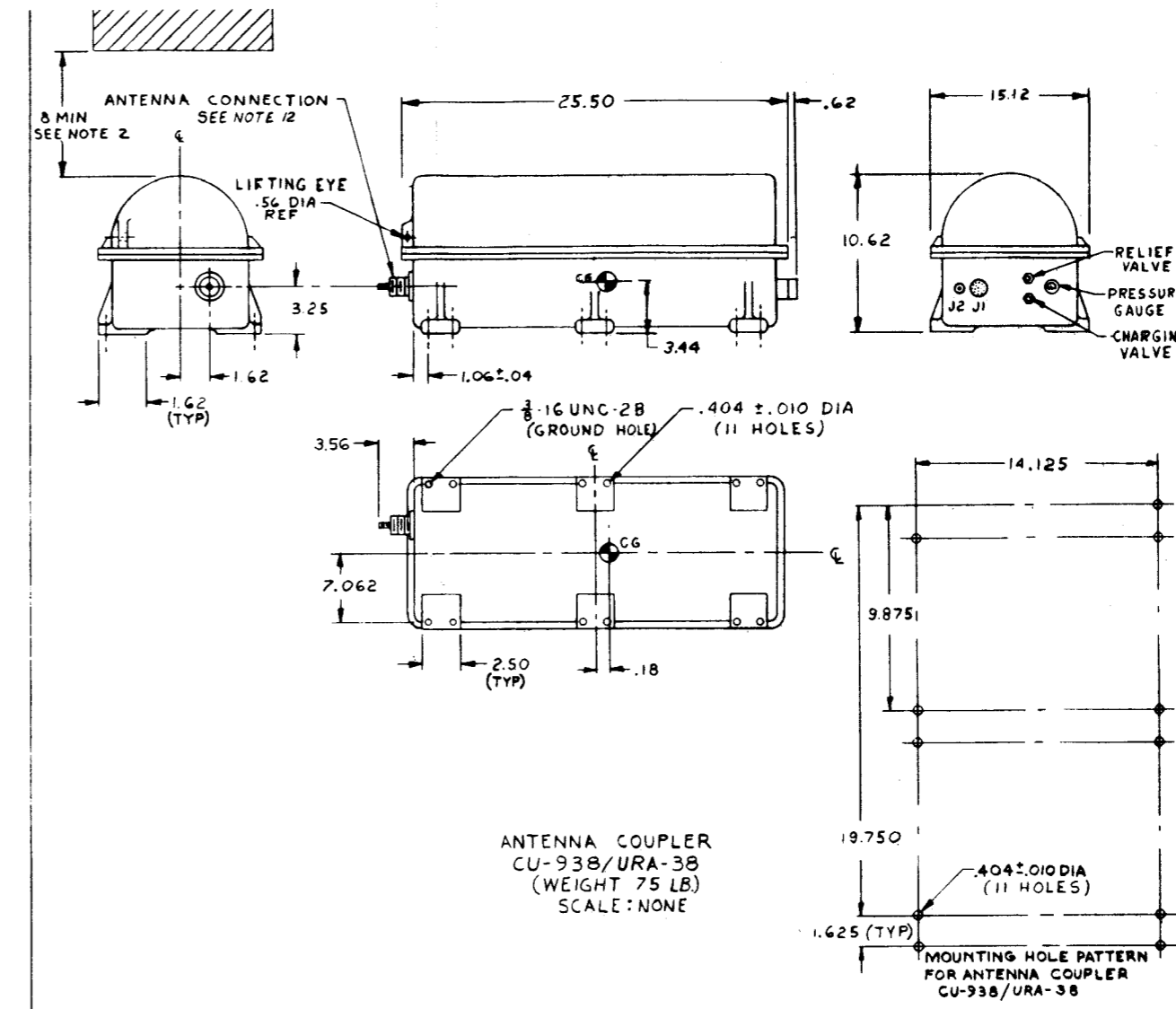

ANTENNA COUPLER  
CU-938/URA-38  
(WEIGHT 75 LB)  
SCALE: NONE

MOUNTING HOLE PATTERN  
FOR ANTENNA COUPLER  
CU-938/URA-38

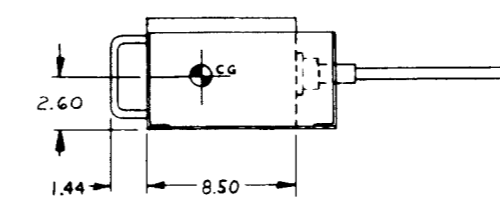

SIDE VIEW

NOTES:

1. THE ANTENNA CONNECTION IS AT HIGH VOLTAGE & MUST HAVE MINIMUM CLEARANCE OF 6 INCHES IN ANY DIRECTION.
2. DIMENSIONS (8" & 18") INDICATE CLEARANCE NECESSARY TO REMOVE CHASSIS FROM THEIR RESPECTIVE CASES.

Figure 2-1. Antenna Coupler Group  
AN/URA-38, Outline Drawing

- c. Possibility of interaction between the units and other electronic equipment and in the vicinity.
- d. Critical cable length requirements.
- e. Availability of an adequate ground.

2-11. ANTENNA COUPLER CU-938/URA-38.

CAUTION

Under certain conditions, the voltages on the CU-938/URA-38 antenna terminal may be as high as 15 KV. Extreme caution must be taken to isolate this 'hot' terminal at least six inches from nearby objects such as cables, guy wires, brackets or ground leads.

2-12. The exact method of mounting the CU-938/URA-38 depends on the type of installation. If possible, the CU-938/URA-38 should be mounted vertically to an aluminum base to provide maximum cooling efficiency. After determining the best location for the CU-938/URA-38, proceed as follows:

- a. Fabricate a mounting surface (aluminum alloy preferred) for the CU-938/URA-38. (The exact size and shape of the surface will depend on the structure on which the CU-938/URA-38 is to be mounted.)
- b. Set the mounting surface on a bench.
- c. Place the CU-938/URA-38 on the selected mounting surface and mark off the mounting holes (eleven required, two for each of the six mounting feet, except the tapped hole used to connect ground strap in right front foot as viewed from antenna terminal).
- d. Drill mounting holes (0.404-inch diameter) in the mounting surface.
- e. Drill or prepare mounting surface as required and attach to supporting structure.

WARNING

To avoid injury to personnel and equipment, do not over-stress mounting bolts since shock may cause them to shear.

- f. Pressurize the CU-938/URA-38 using the procedure in paragraph 2-30.
- g. Attach the CU-938/URA-38 to the mounting surface using eleven 3/8-16 bolts (furnished by the installing activity).
- h. Refer to paragraph 2-19 for interconnection information.

2-13. ANTENNA COUPLER CONTROL C-3698/URA-38.

2-14. The C-3698/URA-38 may be stack-mounted with the AN/URT-23(V), mounted in Electrical Equipment Cabinet CY-4516/S, or hard-mounted adjacent to the associated transmitter. To install the C-3698/URA-38, proceed as follows:

a. To stack mount the C-3698/URA-38 with the AN/URT-23(V), refer to NAVSHIPS 0967-191-7010.

b. To hard mount the C-3698/URA-38, proceed as follows:

- (1) Drill or prepare mounting surface as required.
- (2) Place C-3698/URA-38 on mounting surface.
- (3) Mark off the mounting holes (the two 0.404-inch holes in each bracket).
- (4) Drill the four marked-off holes (0.404-inch diameter).
- (5) Attach the C-3698/URA-38 to the mounting surface with four 3/8-16 bolts (furnished by the installing activity).

c. To rack mount the C-3698/URA-38 in Electrical Equipment Cabinet CY-4516/S, proceed as follows:

- (1) Fabricate the required rack mounting brackets using the information provided in figure 2-2.
- (2) Remove the stack mounting brackets from the C-3698/URA-38 and return them to stock.
- (3) Attach the rack mounting brackets to the sides of the C-3698/URA-38 using the hardware removed from the stack mounting brackets.
- (4) Slide the C-3698/URA-38 into the rack and attach using the required hardware (supplied by the installing activity).

d. Refer to paragraph 2-19 for interconnection information.

2-15. CABLE ASSEMBLIES.

2-16. Variations among installations will determine the length of cables connected to the AN/URA-38. Since the AN/URA-38 is designed to operate primarily with the AN/URT-23(V), the cable (W1), which interconnects the C-3698/URA-38 and the AM-3924(P)/URT, is supplied as a part of the AN/URA-38. The mating connectors required to fabricate the remaining two cables are also supplied. Tables 2-1 through 2-3 list connector terminations and cable type information.

2-17. INTERLOCK INFORMATION.

2-18. When operating the AN/URA-38 with a transmitter other than the AN/URT-23(V), an interlock network should be included between the keyer (handset, CW key, front panel switch, etc.) and the transmitter. This circuit enables the key interlock function to be used, preventing transmitter operation when an overload occurs.

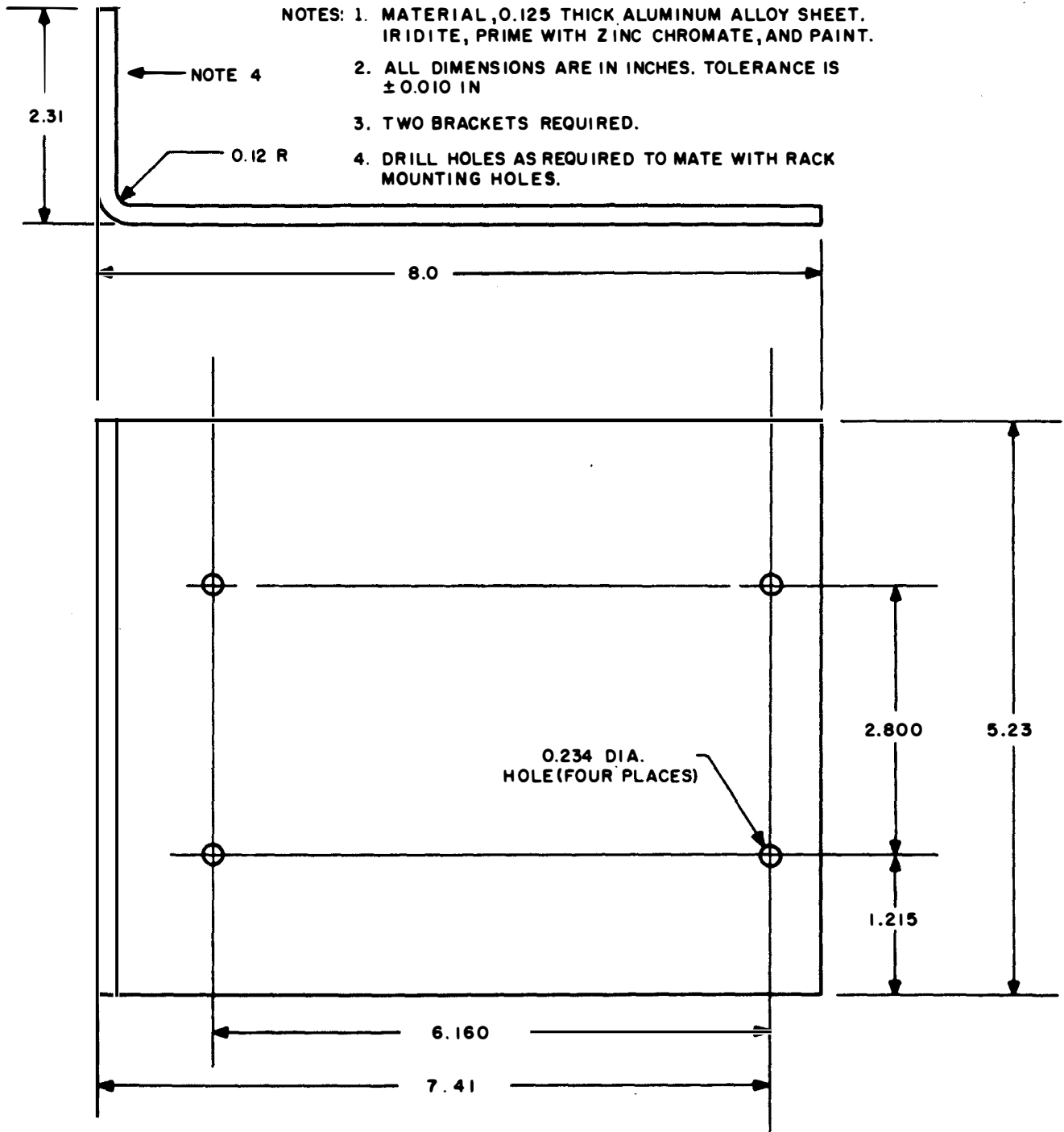

Figure 2-2. Rack Mounting Bracket, Fabrication Diagram

TABLE 2-1. CABLE TYPES AND TERMINATIONS

NO.	FROM	MATING CONNECTOR	CABLE TYPE	MATING CONNECTOR	TO	REMARKS
W1	AM-3924(P)/URT J6	10-109620-27P	Multiconductor	10-109620-27S	C-3698/ URA-38 J1	Supplied as part of AN/URA-38. See table 2-2 for pin connections.
W2	C-3698/URA-38 J2	10-109628-21P	Multiconductor MSCA-37 type (33 active)	10-109628-21S	CU-938/ URA-38 J1	See table 2-3 for pin connections.
W3	Transmitter	---	RG-219/U Coaxial	UG-982/U	CU-938/ URA-38 J2	RF input coaxial cable.
W4	CU-938/URA-38 E1	---	No. 6 stranded copper buss	---	Antenna termi- nation	Maximum length 36 inches, 12 inches preferred.



The interlock also operates while coupler tuning elements are traveling to their "home" position at the start of a tune cycle. Figure 2-3 provides a suggested method for a keyline interlock circuit. Adapt and select components as necessary to fit the specific transmitter.

2-19. INTERCONNECTIONS.

2-20. Interconnect the AN/URA-38 with the associated transmitter and antenna as shown in figure 2-4 and use copper ground straps to connect the equipment cases to the nearest ground plane.

CAUTION

Ensure good metal-to-metal bonding between units,  
and between the units and ground plane.

2-21. INSPECTION AND ADJUSTMENT.

2-22. INSPECTION.

2-23. Carefully inspect the AN/URA-38 for damage to indicators and switches and for loose hardware and knobs. Ensure that the CU-938/URA-38 has been pressurized (paragraph 2-30) by noting the indication on the pressure gage. Loosen the four front panel screws on the C-3698/URA-38 front panel, and open the hinged front panel. Check that all printed circuit boards are firmly seated in their associated connector. Check the connections on terminals 1, 2, and 3 of terminal board TB1. If 60 CPS primary power is being used, terminals 1 and 2 should be jumpered. If 400 CPS primary power is being used, terminals 2 and 3 should be jumpered. Close and secure C-3698/URA-38 front panel. Check connectors for dirt, damage to pins, and broken insulators. Replace or repair as necessary.

2-24. ADJUSTMENT.

2-25. After installation and inspection, refer to Reference Standards Book NAVSHIPS 0967-204-0040 and use the procedures therein outlined to check out the AN/URA-38. Should any adjustments be found necessary, refer to the applicable procedures in Section 5 of this manual. Before beginning the checkout procedures, ensure that all fuses are in place and of the correct value and that all cables are properly connected.

2-26. PERFORMANCE CHECKS.

2-27. To ensure correct installation, perform the procedures in Section 3 for all modes of operation prior to releasing the equipment to operating personnel.

2-28. INTERFERENCE REDUCTION.

2-29. As a precaution against interference, ensure that all units are properly grounded. Operate only with the units bolted securely in their cases.

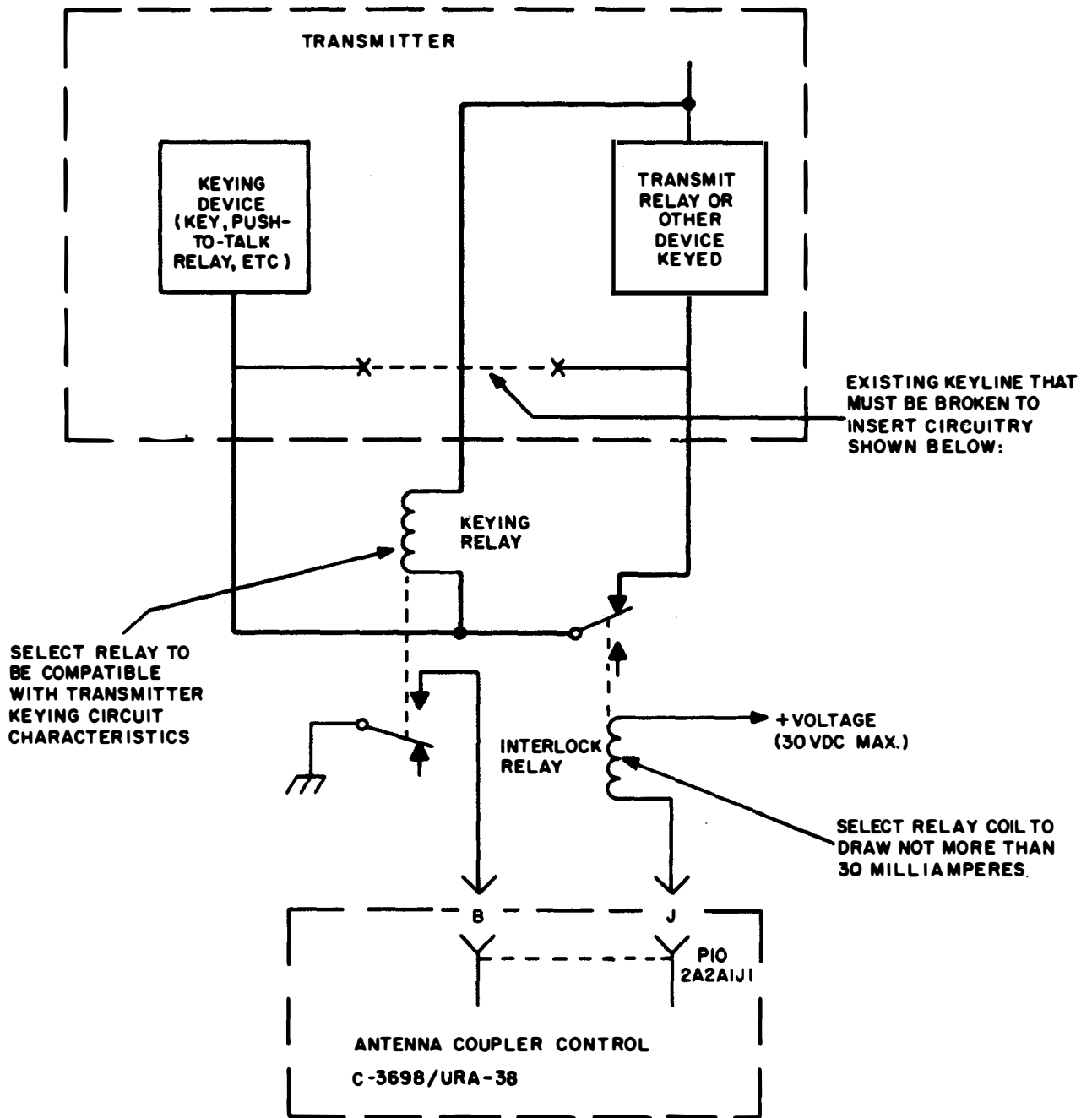

Figure 2-3. Interlock Information Diagram



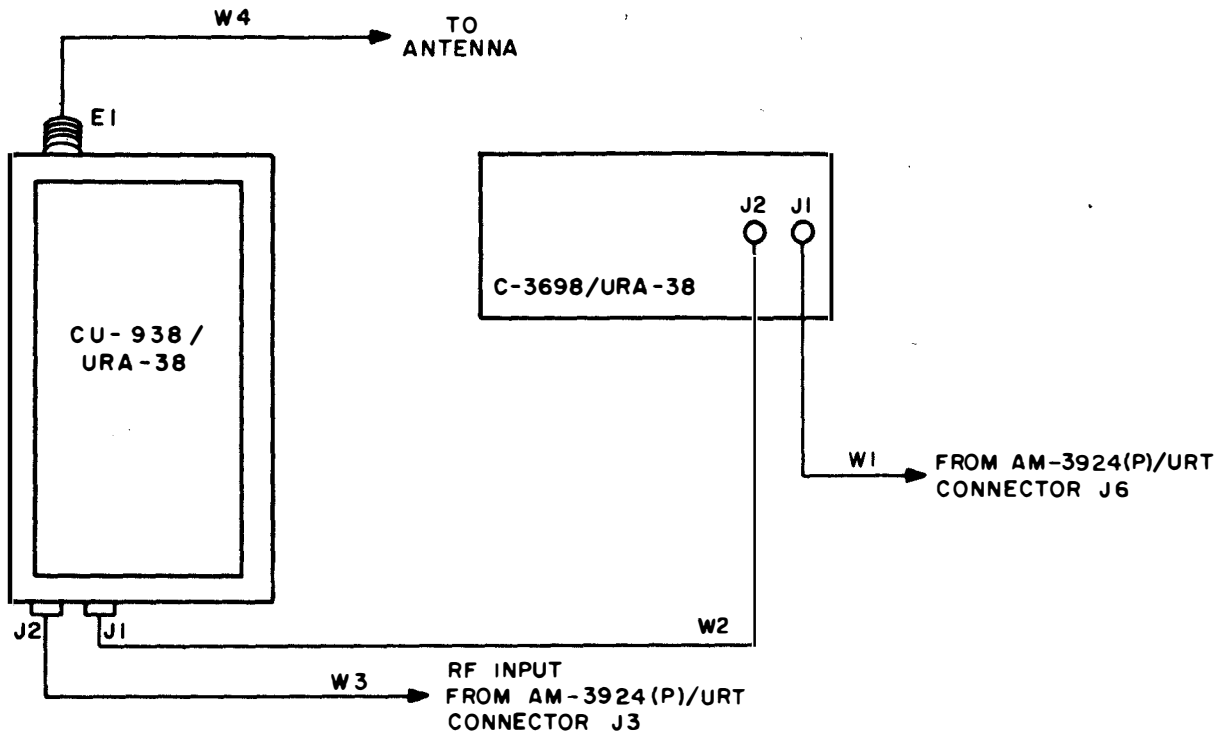

Figure 2-4. Antenna Coupler Group AN/URA-38, Interconnection Diagram

2-30. PRESSURIZATION.

Note

If it is found necessary to remove the CU-938/URA-38 from its case, the case must first be de-pressurized by depressing the core in the charging valve. After the repair has been performed and the unit reassembled in the case, the case must be pressurized using the procedures in paragraph 2-31.

2-31. The CU-938/URA-38 must be pressurized at the time of installation and thereafter as required to maintain the pressure between 2 and 8 PSIG. To accomplish this procedure, use Pressurization Kit MK-260/U and proceed as follows:

- a. Remove the valve cap from the CU-938/URA-38 intake valve (figure 5-3), and attach Pressurization Kit MK-260/U to the intake valve.
- b. Set the regulator on the MK-260/U at 10 PSIG.
- c. Open the nitrogen tank valve, and allow the CU-938/URA-38 to fill to 8 PSIG
- d. Turn the nitrogen tank valve off, and disconnect the MK-260/U from the CU-938/URA-38.

- e. Replace the valve cap on the CU-938/URA-38 intake valve.

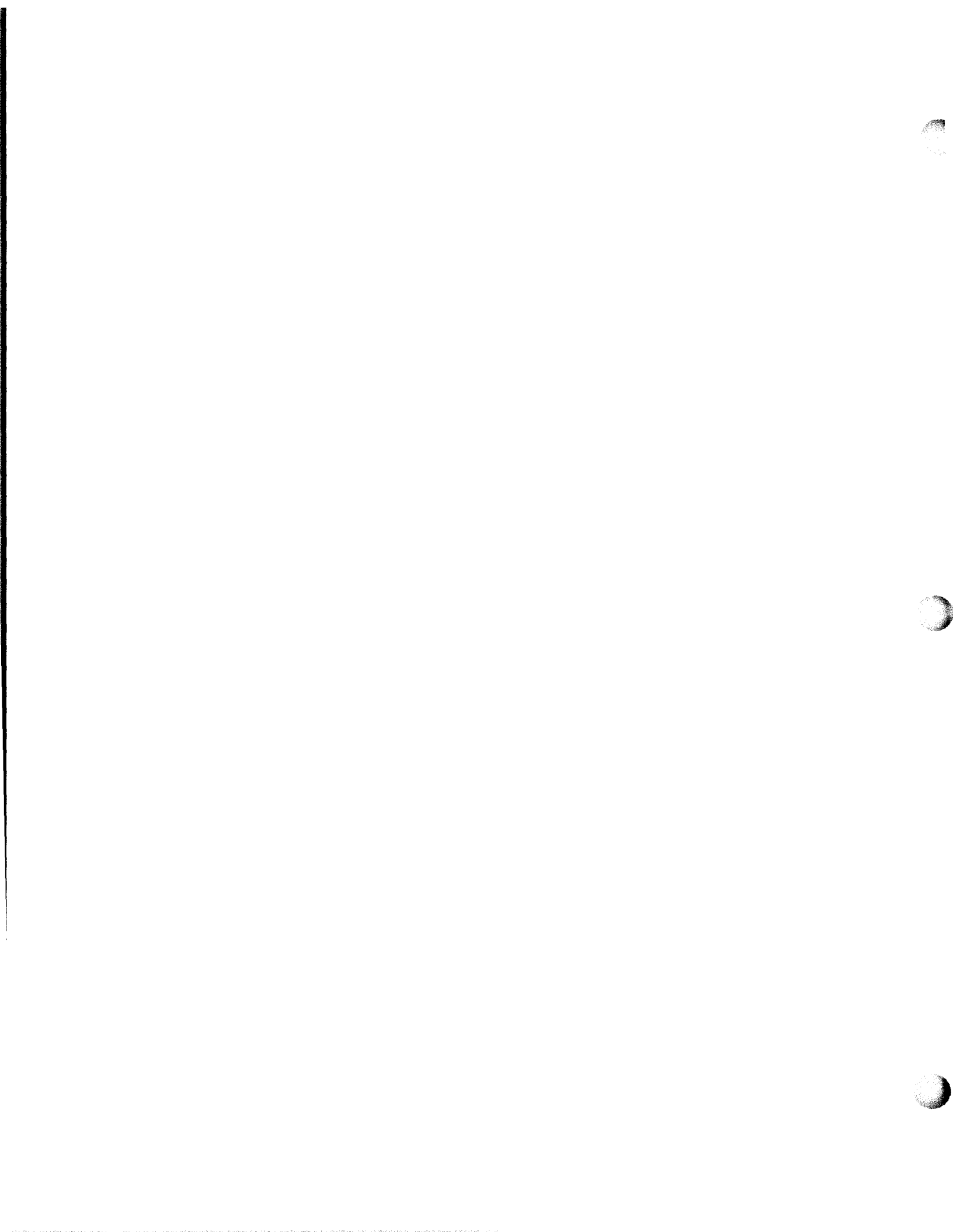

SECTION 3  
OPERATION

3-1. FUNCTIONAL OPERATION.

3-2. GENERAL.

3-3. Antenna Coupler Group AN/URA-38 is an automatic antenna tuning system that is capable of matching the impedance of a 15, 25, 28 or 35 foot whip antenna to the impedance of a 50-ohm transmission line at any frequency in the 2.0 to 30.0 MC range. Once tuned, the AN/URA-38 is capable of handling LSB, USB, ISB, FSK, CW, and Compatible AM transmissions at a nominal power rating of 1 KW average and PEP. The AN/URA-38 is primarily intended for use with Radio Transmitting Set AN/URT-23(V). However, to enable operation with other radio transmitters, the equipment design includes provisions for manual and semi-automatic tuning. Manual tuning is also useful if a failure occurs in the automatic tuning circuits. In addition, tuning can be accomplished without using RF power (silent operation). This method is useful in installations where radio silence must be maintained except for brief transmission periods.

3-4. The AN/URA-38 consists of two units: Antenna Coupler CU-938/URA-38 and Antenna Coupler Control C-3698/URA-38. These two units contain an impedance transformation circuit which includes two servo driven tuning elements, a logic circuit, a metering and switching circuit, an overload protection circuit and a power supply. The operation of these circuits in each of the possible modes is explained in paragraphs 3-5 through 3-10.

3-5. OPERATION.

3-6. AUTOMATIC. During automatic operation (Mode Selector switch set at AUTO), the logic circuit produces signals to control and sequence the tuning of the AN/URA-38. When a home cycle is initiated, the logic circuit supplies a signal to position the motor-driven tuning elements at home (starting position). The home cycle is initiated each time primary power is applied, a frequency change of 1 kHz or more is made, by depressing the front panel RETUNE switch and recovery from a power mains outage. After completing the cycle the operation halts with the elements at home until the operator keys the transmitter. The logic circuits then automatically hold the transmitter keyed, reduce the transmitter RF power output, and energize the servo loops for a tune cycle. During this cycle, the correction signals are produced to energize the servo motors for a direction of rotation which will move the tuning elements to the tuned position. The direction of rotation is reversed as required throughout the tuning cycle. Once the tuning cycle is completed, the transmitter key line is released and the READY indicator lamp lights to indicate that the CU-938/URA-38 is ready for full power operation. During full power operation, the servo loops fine tune the tuning elements to compensate for changes in antenna impedances.

3-7. MANUAL. During manual operation (Mode Selector switch set at MANUAL), the operator must manually position the tuning elements at home, reduce the transmitter RF power and key the transmitter. The tuning elements are then alternately positioned for a null indication on the DISCRIMINATOR NULL meter using the LEFT and RIGHT pushbuttons. The element whose position is being changed is selected through the L-C switch. The READY indicator lamp and fine tuning circuits are inoperative during manual operation.

3-8. SEMI-AUTOMATIC. During semi-automatic operation (Mode Selector switch set at AUTO), the operator must manually reduce RF power, depress the RETUNE pushbutton, and key the transmitter. The tuning elements then will be automatically tuned. The READY indicator lamp will light when tuning is completed. During full power operation, the servo loops will energize as required to fine-position the tuning elements to compensate for changes in antenna impedance. (An interlock network is required between the AN/URA-38 and transmitter to operate semi-automatically as explained in paragraph 2-17.)

3-9. SILENT. During silent operation (Mode Selector switch set at SILENT), the elements are positioned one at a time with the LEFT and RIGHT pushbuttons for a pre-recorded indication on the ELEMENT POSITION meter without using RF power. The element whose position is being moved is selected with the L-C switch. The READY indicator lamp is inoperative during silent operation. However, the servo loops are energized to fine-position the elements as required throughout the transmission to compensate for changes in antenna impedance.

3-10. OVERLOAD PROTECTION. Circuits are provided to interlock the keyline of the transmitter if a pressure or temperature overload exists in the CU-938/URA-38. The Overload alarm and OVERLOAD indicator lamp are energized any time an overload exists, providing visual and audible indication of the condition.

3-11. OPERATING PROCEDURES.

3-12. DESCRIPTION OF OPERATING CONTROLS AND INDICATORS.

3-13. All controls and indicators required for the operation of the AN/URA-38 are located on the C-3698/URA-38 front panel (figure 3-1). Table 3-1 lists each operating control and indicator and its function.

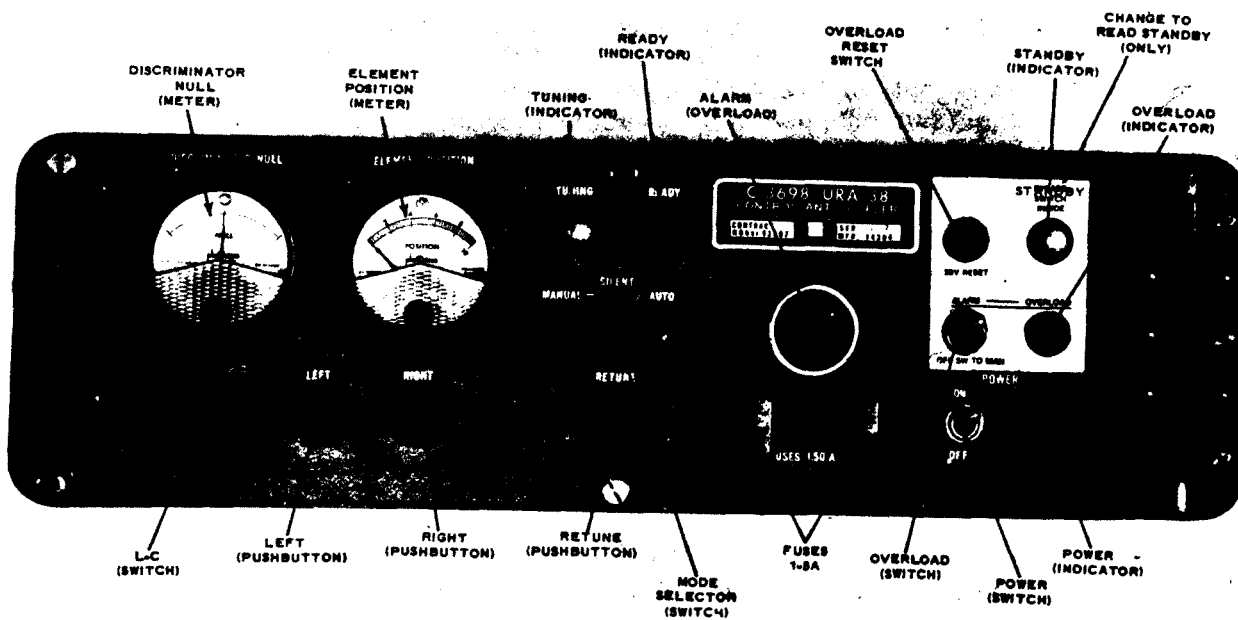

Figure 3-1. Antenna Coupler Control C-3698/URA-38, Operating Controls and Indicators

TABLE 3-1. ANTENNA COUPLER CONTROL C-3698/URA-38, OPERATING CONTROLS AND INDICATORS

CONTROL/INDICATOR	FUNCTION								
DISCRIMINATOR NULL meter	Provides an indication of L or C element mistuning as selected by L-C switch during manual mode of operation.								
ELEMENT POSITION meter	Provides an indication of L or C element positioning as selected by L-C switch.								
L-C switch	Selects metering and switching required to tune L or C element during manual and silent modes of operation.								
LEFT pushbutton	When depressed, tuning element selected by L-C switch is repositioned in a direction which moves deflection of DISCRIMINATOR NULL or ELEMENT POSITION meter to left of scale.								
RIGHT pushbutton	When depressed, tuning element selected by L-C switch is repositioned in a direction which moves deflection of DISCRIMINATOR NULL or ELEMENT POSITION meter to right of scale.								
TUNING indicator lamp	Lights when either servo motor is energized.								
READY indicator lamp	Lights when elements have been correctly tuned during automatic mode of operation.								
Mode Selector switch	<p>Selects AN/URA-38 mode of operation:</p> <table border="0" data-bbox="808 1251 1450 1503"> <tr> <td style="padding-right: 20px;">Switch Position</td> <td>Equipment Response</td> </tr> <tr> <td>MANUAL</td> <td>Permits manual tuning.</td> </tr> <tr> <td>SILENT</td> <td>Permits coarse manual tuning without RF power. Fine tuning is automatic when keyed.</td> </tr> <tr> <td>AUTO</td> <td>All tuning is automatic.</td> </tr> </table>	Switch Position	Equipment Response	MANUAL	Permits manual tuning.	SILENT	Permits coarse manual tuning without RF power. Fine tuning is automatic when keyed.	AUTO	All tuning is automatic.
Switch Position	Equipment Response								
MANUAL	Permits manual tuning.								
SILENT	Permits coarse manual tuning without RF power. Fine tuning is automatic when keyed.								
AUTO	All tuning is automatic.								
RETUNE pushbutton	When depressed with Mode Selector switch at AUTO or SILENT, a home cycle is initiated.								
Overload alarm	Provides an audible indication when a pressure or temperature overload exists in the CU-938/URA-38. (OVERLOAD switch must be set at ALARM. (Mode selector switch at Auto or Silent)								
FUSES 1.50A (with indicators)	Protect the AN/URA-38 against overload; indicators glow when fuse is open.								

TABLE 3-1. ANTENNA COUPLER CONTROL C-3698/URA-38, OPERATING CONTROLS AND INDICATORS (Cont)

CONTROL/INDICATOR	FUNCTION
STANDBY indicator lamp	Lamp will be lighted except when the associated transmitter is Keyed. The lamp provides visual indication of the Key Hold and Surveillance Defeat circuits.  Lights when CU-938/URA-38 matching network is bypassed.
OVERLOAD switch	When set at ALARM, audible overload alarm is connected to overload circuit.
OVERLOAD indicator lamp	Lights to provide visual indication when a pressure or temperature overload exists in CU-938/URA-38.
POWER switch	Controls primary power application to AN/URA-38.
POWER indicator lamp	Lights when AN/URA-38 is energized.

3-14. AUTOMATIC OPERATION.

3-15. Automatic operation is normally possible only when operating with the AN/URT-23(V). To operate the AN/URA-38 in an automatic mode of operation, proceed as follows:

Note

Unless diode A2CR7 in Radio Transmitter T-827/URT is shorted (Refer to NAVSHIPS 0967-191-7010), the AN/URA-38 will not automatically tune when the AN/URT-23(V) is operating in a CW or FSK mode. Either this diode must be shorted, or the AN/URT-23(V) must be set for a different mode of operation for initial tune-up; thereafter, normal transmissions can be made in any mode.

- a. Energize transmitter at desired operating frequency.
- b. Set Mode Selector switch at AUTO.
- c. Set POWER switch at ON. POWER indicator lamp should light. TUNING indicator lamp should light briefly, unless tuning elements are already at home.

d. When TURNING indicator lamp extinguishes, momentarily key transmitter. READY indicator lamp will light when AN/URA-38 is ready for full power operation.

e. Key transmission as required.

f. If a home cycle is initiated during operation (frequency change, depressing RETUNE pushbutton, the READY indicator lamp will extinguish and TUNING indicator lamp will momentarily light, indicating that the tuning elements are returning to home. When TUNING indicator lamp extinguishes, repeat step d.

g. If a pressure or temperature overload occurs during operation, the OVERLOAD indicator lamp will light, the audible Overload alarm will energize and the keyline will interlock. Operation will be inhibited until cause of overload condition is removed. If desired, the Overload Alarm can be de-energized by setting ALARM switch at OFF and switching from AUTO to MANUAL. Most OVERLOAD conditions are from the CU-938 pressure falling below 2 psig rather than a temperature of 285 deg. F on 1A2L1.

#### NOTE

If silent operation is expected, perform steps a and d for each assigned operating channel. At each channel, set L-C switch at L and then C. Record ELEMENT POSITION meter indication for both positions of L-C switch at each operating channel on Table 3-3.

#### 3-16. SEMI-AUTOMATIC OPERATION.

3-17. The AN/URA-38 can be operated in a semi-automatic mode when the associated transmitter is not the AN/URT-23(V). To operate in the semi-automatic mode, proceed as follows:

#### CAUTION

If the equipment is to be operated in this manner, some means must be provided to open the keyline to the transmitter when the C-3698/URA-38 keyline interlock is grounded (paragraph 2-17).

a. This step must be performed the first time operation is accomplished on any one specific frequency. Thereafter, begin operation with step b.

- (1) Ensure that transmitter is unkeyed.
- (2) Decrease RF power output control on transmitter to zero, and connect a 50-ohm dummy load to transmitter output.
- (3) Energize transmitter at desired frequency of operation.
- (4) Key transmitter and increase power output to approximately 200 watts. Note and record amount of input drive, setting of power control, etc., required to obtain 200 watts at that operating frequency. Release key. Remove dummy load and reconnect RF cable.



- b. Set transmitter for a 200 watt output at the desired operating frequency according to pre-recorded information obtained in step a(4).
- c. Set Mode Selector switch at AUTO.
- d. Set POWER switch at ON. POWER and TUNING (unless elements are already at home) indicator lamps should light.
- e. When TUNING indicator lamp extinguishes, key transmitter.
- f. When READY indicator lamp lights, increase transmitter RF power output to desired operate level.
- g. Key transmission as required.

CAUTION

If it is desired to change frequencies, the following sequence must be observed to preclude damage to the equipment. Release transmitter key, depress RETUNE pushbutton, change frequency, adjust transmitter to previously recorded 200W setting for the new frequency, key transmitter, perform steps f and g above.

h. If a temperature or pressure overload occurs during operation, the OVERLOAD indicator lamp will light, the Overload alarm will energize, and the keyline will interlock.

If this occurs, correct the cause of the condition before continuing operation.

i. If RETUNE pushbutton is depressed during operation, the READY indicator lamp will extinguish and the TUNING indicator lamp will momentarily light, indicating that the tuning elements are returned to home. When TUNING indicator lamp extinguishes, repeat steps b, and e through g.

3-18. MANUAL OPERATION.

3-19. If a failure occurs in the automatic tuning circuitry, the AN/URA-38 can be manually tuned. This mode of operation may also be used when operating with a transmitter other than the AN/URT-23(V). To operate the AN/URA-38 manually, proceed as follows:

a. Perform steps a and b of paragraph 3-17 as required when operating with a transmitter other than AN/URT-23(V). When operating with AN/URT-23(V), select frequency with T-827/URT MCS and KCS controls.

- b. Set Mode Selector switch at MANUAL.
- c. If retuning is needed, use paragraph 3-19 Page 3-6/7.
- d. When cause of overload is repaired set Mode Selector switch to AUTOMATIC Operation and Overload ALARM Switch to ON.

NOTE

Continue operation with reduced power when overload occurs. The equipment should not be operated in this condition any longer than absolutely necessary since its life will be greatly reduced.

- e. Set POWER switch at ON. POWER indicator lamp will light.
- f. Set L-C switch at C.
- g. Depress RIGHT pushbutton until TUNING indicator lamp extinguishes.
- h. Momentarily depress LEFT pushbutton.
- i. Set L-C switch at L and repeat step e.
- j. If AN/URT-23(V) is being used, set key switch at TUNE KEY. When operating with some other transmitter, key a reduced power output as required. DISCRIMINATOR NULL meter will indicate to the right of NULL indication.
- k. Depress LEFT pushbutton until DISCRIMINATOR NULL meter indication reaches center mark. ..

NOTE

The DISCRIMINATOR NULL meter indication may go to the right before going left; this is normal.

- l. Set the L-C switch at C.
- m. Depress LEFT pushbutton until DISCRIMINATOR NULL meter indication reaches center mark.
- n. Alternately set L-C switch to L and C and depress LEFT or RIGHT pushbuttons momentarily to move DISCRIMINATOR NULL meter indication to center mark.
- o. Repeat step l until DISCRIMINATOR NULL meter indicates at NULL position for both positions of L-C switch.

NOTE

The null at some frequencies is very sharp. This requires the procedure to be performed very slowly and carefully to obtain a tuned (NULL) indication.

NOTE

The READY indicator lamp is inoperative during manual operation.

P. Increase transmitter RF power output to 1KW. (If AN/URT-23(V) is being used, set AM-3924(P)/URT Key switch at NORMAL, and key system as required by mode of operation.)

q. Periodically during transmission, alternately set L-C switch to L and C and check for a NULL indication on DISCRIMINATOR NULL meter. Fine tune as required using LEFT and RIGHT pushbuttons.

r. If a temperature or pressure overload occurs during operation, the OVERLOAD indicator lamp will light, the Overload alarm will energize and the keyline will interlock. If this occurs, correct the condition before continuing operation.

### 3-20. SILENT OPERATION.

3-21. If the AN/URA-38 is being operated under radio silence conditions, the tuning can be accomplished in the silent mode without the use of RF power by using meter settings previously obtained in paragraph 3-15 for each assigned operating channel. To operate the AN/URA-38 in the silent mode, proceed as follows:

#### NOTE

The READY indicator lamp is inoperative during silent operation.

- a. Turn transmitter primary power on.
- b. Set Mode Selector switch at SILENT.
- c. Set POWER at ON. POWER indicator lamp will light. TUNING indicator lamp will briefly light unless tuning elements are already at home.
- d. Set L-C switch at L.
- e. Depress LEFT and RIGHT pushbuttons as required to provide an indication on ELEMENT POSITION meter that is the same as the pre-recorded value for the frequency to be used.
- f. Set L-C switch at C.
- g. Repeat step e for the pre-recorded C element position.
- h. Set transmitter to operating frequency for which the elements were tuned.
- i. Key transmission as required. Fine tuning will be performed automatically.
- j. If a frequency change is made, the tuning elements will go to home. Tuning can then be performed using d through g above.
- k. If a temperature or pressure overload occurs, the OVERLOAD indicator lamp will light, the Overload alarm will energize, and the keyline will interlock. Transmission will be inhibited until the condition causing the overload is corrected.

3-22. EMERGENCY OPERATION.

3-23. If a temperature or pressure overload occurs during automatic or silent operation, the logic circuits will interlock the keyline to prevent the AN/URT-23(V) from being keyed. If this occurs and it is necessary to maintain operation, proceed as follows:

- a. Set ALARM switch at OFF, set Mode switch to manual and proceed as in 3-24.

3-24. If a temperature or pressure overload occurs when operating in the manual mode, the transmitter interlock line is not interlocked unless the associated transmitter is the AN/URT-23(V), or the interlock network (paragraph 2-17) is used. If the associated transmitter is the AN/URT-23(V) or the interlock network is used, perform step a paragraph 3-23. Otherwise, set the ALARM switch at OFF and continue operation at a power level as low as is commensurate with reliable communications.

3-25. If the AN/URA-38 will not automatically tune, set Mode Selector switch at Manual and attempt to tune using the procedures in paragraph 3-19. If the AN/URA-38 still does not tune, try steps b through g of paragraph 3-21 to position the elements. If the elements still cannot be positioned, the equipment is inoperative at that frequency, or the antenna cannot be tuned at the frequency due to a malfunction of the antenna.

3-26. OPERATOR'S MAINTENANCE.

3-27. OPERATING CHECKS.

3-28. When a system malfunction is encountered, the operator should perform the following checks to determine the cause of the trouble.

- a. Check the two fuses; if either is open, the associated indicator lamp will light. Replace open fuses. If fuse opens again, refer problem to maintenance personnel.
- b. Check all cables for breakage and connectors for proper connection and seating.
- c. Check to see that the POWER indicator lamp is lighted. If operating with the AN/URT-23(V), the AN/URT-23(V) must be energized in order for primary power to be applied to the AN/URA-38.
- d. Check to see that the Mode Selector switch is set for the desired mode of operation.

NOTE

Usually "L" must be adjusted first on frequencies below approximately 13 Mhz, and "C" must be adjusted first for frequencies above 13 Mhz. If the wrong element is adjusted first, an initial null may be difficult to obtain and on some higher frequencies, a false null may be obtained.

e. Check ELEMENT POSITION meter indication at both settings of the L-C switch. If indications are approximately 9, or more, perform the operating procedures to retune.

3-29. PREVENTIVE MAINTENANCE.

3-30. The preventive maintenance procedures that can be performed by the operator are listed in table 3-2.

TABLE 3-2. ANTENNA COUPLER GROUP AN/URA-38, PREVENTIVE MAINTENANCE CHECKS

INSPECT FOR	REMEDY
Low pressure in CU-938/URA-38	Recharge CU-938/URA-38 using the procedures in paragraph 2-30, and check for leaks.
Loose handles, mounting screws, and other hardware	Tighten loose hardware.
Cable assemblies, broken, frayed or damaged	Repair or replace.
Dust	Clean exterior with soft lint-free cloth. Clean interior with brush, cloth and compressed air.
Nicks, burrs, dents, scratches or rust	Smooth burrs with file, sandpaper corrosion, rust or scratches and refinish.

3-31. EMERGENCY MAINTENANCE.

3-32. If the system malfunctions while a technician is not available, the operator should perform the following emergency procedures.

- a. Try another mode of operation.
- b. Perform steps a through e of paragraph 3-28.
- c. Loosen front panel screws and open hinged front panel. Check that all printed circuit boards are properly seated in their associated connectors.
- d. Check for a damaged antenna.

*3-31c. \*cont'd - see EIB 819 for additions on 3-31.c.*

TABLE 3-3. LOGGED ELEMENT POSITIONS

ANTENNA TYPE \_\_\_\_\_

FREQ(MHz)	L	C

FREQ(MHz)	L	C

ANTENNA TYPE \_\_\_\_\_

FREQ(MHz)	L	C

FREQ(MHz)	L	C

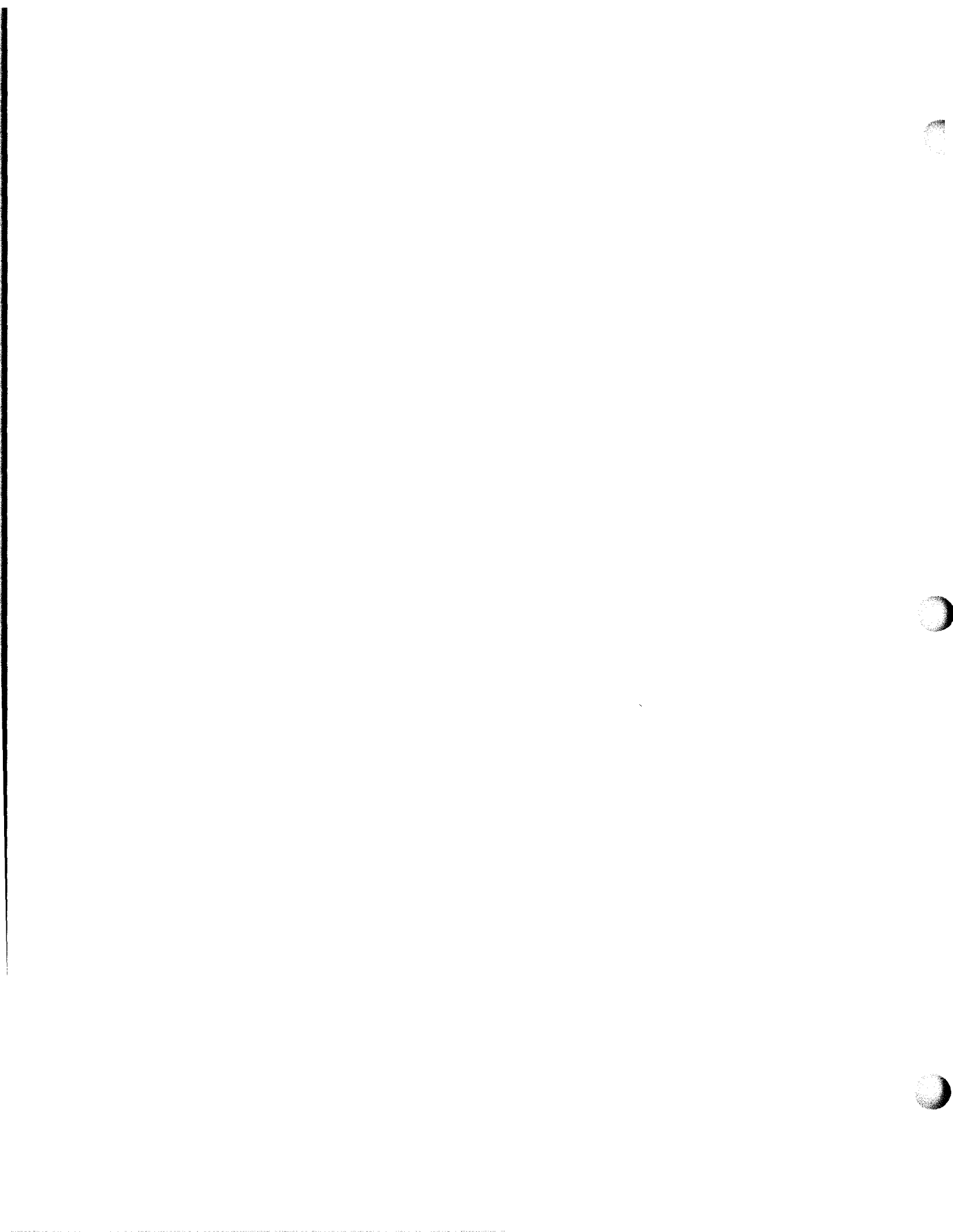

SECTION 4  
TROUBLESHOOTING

4-1. LOGICAL TROUBLESHOOTING.

4-2. The following six logical steps should be followed when troubleshooting Antenna Coupler Group AN/URA-38.

4-3. SYMPTOM RECOGNITION.

4-4. Symptom recognition, the first step in the troubleshooting procedure, is based on complete knowledge and understanding of equipment operating characteristics. Not all equipment troubles are the direct result of component failure; therefore, a trouble in the equipment is not always easy to recognize, since conditions of less than peak performance are not always apparent. This type of trouble is usually discovered during preventive maintenance, such as the Performance Operation and Maintenance Standards of Electronic Equipment (POMSEE) checks.

4-5. SYMPTOM ELABORATION.

4-6. After an equipment trouble has been recognized, use of front panel controls and other built-in indicating or testing aids should verify the original symptom. Checking or manipulating the setting of the operating controls may eliminate the trouble. Common troubles and an isolation procedure for each are listed in paragraph 4-105.

4-7. LISTING PROBABLE FAULTY FUNCTION.

4-8. The next step in logical troubleshooting is to list some "logical choices" of the cause and probable location (functional section) of the trouble. The "logical choices" are based on knowledge of equipment operation, identification of the trouble symptom, and information contained in this manual. Refer to the Antenna Coupler Group AN/URA-38 functional description and associated functional block diagram.

4-9. LOCALIZING THE FAULTY FUNCTION.

4-10. For test efficiency in localizing trouble, the "logical choices" should be checked in the order that will require the least time; a selection is required to determine which section to test first. The selection should be based on the validity of the "logical choices" and the difficulties involved in making the necessary tests. If the tests do not prove that one functional section is at fault, the next selection should be tested, and so on until the faulty section is located.

4-11. Voltage levels are included at significant check points on the servicing block diagram to aid in isolating the faulty functional section. Test data (such as information on critical adjustments and required test equipment) are supplied to augment the functional description and servicing block diagram.



4-12. LOCALIZING TROUBLE TO THE CIRCUIT.

4-13. After the faulty functional section has been isolated, it is often necessary to make additional "logical choices" as to which circuit(s) within the functional section is at fault. The servicing block diagrams provide the signal flow information to bracket and isolate the faulty circuits. Table 5-2 provides a list of transistor DC voltage levels for various operating conditions. Functional descriptions, simplified schematics, and pertinent test data for individual circuits (stages) of the functional section are in one area of the manual. Usually, this information is on facing pages. Information too lengthy for this arrangement is in the test data portion of the troubleshooting information.

4-14. FAILURE ANALYSIS.

4-15. After the trouble, faulty component, misalignment, etc. has been located, but prior to performing the corrective action, the procedures followed up to this point should be reviewed to determine why the fault affected the equipment as it did. This review is necessary to make certain that the fault discovered is actually the cause of the malfunction, and not a result of the malfunction.

4-16. FUNCTIONAL DESCRIPTION.

4-17. GENERAL.

4-18. The AN/URA-38 is an automatic antenna coupler group consisting of two units: the CU-938/URA-38 and the C-3698/URA-38. These units are for general purpose surface ship and shore use with Radio Transmitting Set AN/URT-23(V). However, the AN/URA-38 may be manually tuned when operated with other transmitters. Additional provisions permit tuning without RF power. This is useful where radio silence must be maintained except during brief transmission periods. The AN/URA-38 matches the impedance of a 15, 25, 28, or 35 foot whip antenna to a 50 ohm transmission line at any frequency in the 2.0 to 30.0 MC range. The AN/URA-38 will handle up to 1 KW of PEP or average power in an LSB, USB, ISB, CW, FSK, or Compatible AM mode, Figure 4-1 illustrates the relationship of the functional sections of the AN/URA-38.

4-19. The RF input from the transmitter is applied through the phase ( $\phi$ ) and resistance (R) discriminators to the matching network. The matching network consists of a transformer, a variable capacitor, and a variable inductor. The two variable tuning elements are motor driven to a tune position in an automatic, manual, or silent mode of operation (paragraphs 4-28 through 4-29). When tuned, the matching network transforms the antenna impedance at the selected operating frequency to a 50 ohms resistive impedance. The discriminators sample line voltage and current to measure deviations in the resistive and reactive components of the line impedance from the desired 50 ohms resistive impedance. If a deviation exists, the appropriate discriminator produces an error with a polarity that is indicative of the direction of the deviation. The error signals are applied through a switching and metering network to the servo amplifiers (automatic operation) or to the DISCRIMINATOR NULL meter (manual operation) so that the impedance of the variable tuning elements in the matching network can be adjusted. (The discriminators do not produce an output while manually pretuning the elements in silent operation.)

4-20. The toroidal transformer 1A2T1 serves in its impedance stepdown capacity mainly in the 5 mhz region when the coupler is used with a 35 foot whip. At the higher frequencies the winding capacitance couples the energy directly to

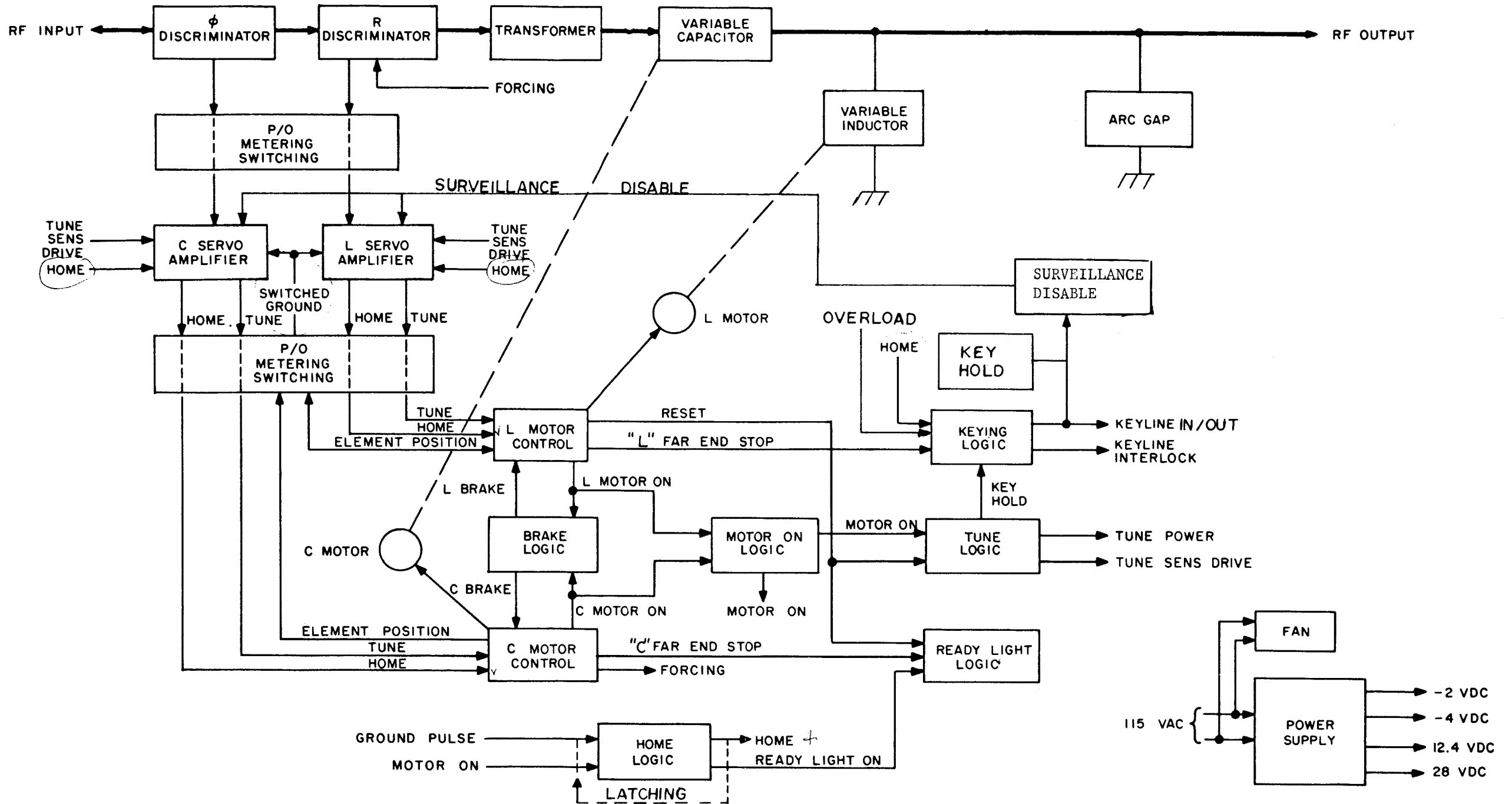

Figure 4-1. Antenna Coupler Group  
AN/URA-38, Functional Block Diagram

4-20 (continued) the output tap so that no function is served. Should 1A2T1 fail, the coupler can be restored to most of its operating capability by eliminating it from the circuit. Remove the leads from terminals 2 and 3 and make a direct connection from the output (solder) connection of the Discriminator to the point on the vacuum capacitor where terminal 2 of 1A2T1 was made. The associated transmitter should be tagged to show that 1A2T1 is being requisitioned and that normal operation can be expected except on some frequencies.

#### 4-21 AUTOMATIC TUNING CYCLE.

4-22 An automatic tuning cycle is initiated by one of the following: energizing the system, changing the AN/URT-23(V) operating frequency, depressing the RETUNE switch, reapplying primary power. In any case, a ground pulse is applied to the input to the home logic, producing a positive home signal to the servo amplifiers and keying logic. This positive level energizes the keyline interlock output to the AN/URT-23(V), preventing the system from being keyed while the tuning elements are traveling to home. The positive home signal applied to the servo amplifiers tune on their respective home output stages, grounding the home output lines. The home lines are connected directly (through a switching network used during manual and silent operation) to the motor control circuits. With the home input lines grounded, the two motor control circuits apply a ground to one side and 28 VDC to the other side of their respective servo motors with a polarity that drives the tuning elements to home. The grounds are also applied as L motor-on and C motor-on signals to both the brake logic and the motor-on logic. This produces a positive motor-on output signal from the motor-on logic which is applied to the home logic to lock that circuit on until the tuning elements reach home. The motor-on grounds energize the brake logic to release the motor brakes.

4-23 As each tuning element reaches home, its home end stop switch breaks the ground connection to its servo motor. Thus, the motor-on signal for that element is removed from the brake and motor-on logic circuits. The brake logic for the respective motor de-energizes, engaging the brake for that motor. Also, when the variable capacitor reaches home, its end stop switch supplies a forcing ground signal to the R discriminator (paragraph 4-24). When the variable inductor reaches home, its end stop switch supplies a reset (ground) signal to the tune and ready light logic. This reset ground is applied through the tune logic to the AN/URT-23(V) as the tune power signal. The reset ground also sets the sensitivity of the servo amplifiers to maximum as required for low power (50 to 250 watt) tuning. The cycle halts at this point and remains in the conditions mentioned above until the system is keyed.

4-24 Momentarily keying the system releases the key interlock (after a slight time delay by the interlock logic), allowing the system to assume a keyed condition. Since the tune power signal is being applied to the transmitter, a low level (200 watt) output from the AN/URT-23(V) is applied to the CU-938/URA-38. The  $\phi$  discriminator samples RF line voltage and current to produce a DC error signal proportional to the deviation of the line reactance from 0 ohms. The  $R$  discriminator samples RF line voltage and current to produce a DC error signal proportional to the deviation of the line resistance from 50 ohms. These error signals are applied through the metering and switching circuit to the servo amplifiers. The servo amplifiers will turn on, grounding the tune output lines to their respective motor control circuits. With the tune input lines grounded, the motor control circuits apply a ground to one side and 28 VDC to the other side of their respective servo motors with a polarity that drives the tuning elements towards a tune position. The grounds are also applied to the brake logic to release the motor brakes. As the tune point is approached, it is sometimes necessary for the elements to be jockeyed back and forth; the polarity of the discriminator outputs change as required to cause the motors to be driven in the right direction. For some antenna impedances at the lower part of the frequency range, the normal level of the error signals from the discriminators is not sufficient to turn on the servo amplifiers; therefore,

a forcing ground (paragraph 4-23) is applied to unbalance the R discriminator, resulting in an error signal of sufficient level to the L servo amplifier. This forces the variable inductor to move in a tune direction. The forcing continues until the impedance changes sufficiently to produce an output from the  $\phi$  discriminator. At this time, the variable capacitor will move in a tune direction, opening its home end stop switch. This removes the forcing ground to the R discriminator, allowing normal tuning to take over.

4-25. The individual motor-on grounds applied to the brake logic are also applied to the motor-on logic while tuning as during the home cycle. Therefore, the motor-on logic produces a positive motor-on output which is applied to the tune logic circuits. This positive level energizes the tune logic to lock in the tune power ground to the AN/URT-23(V) and tune sensitivity drive signal to the servo amplifiers, and produces a key hold signal to the keying logic. The key hold signal energizes the keying logic to lock in the system key. (The motor-on signal is also applied to the home logic, but an internal clamp prevents that circuit from being energized.) When the tuning elements reach their respective tune positions, the servo logic circuits change state to remove the key, motor-on, tune power, and tune sensitivity drive signals and engage the motor brake. This removes all inhibits from the ready light logic. Therefore, the READY light is energized, indicating that the tune cycle has been completed. The automatic tuning cycle requires a maximum of 5 seconds to complete. When the system is now keyed, a full (1KW) RF power level is applied to the CU-938/URA-38 by the AN/URT-23(V). As conditions change the antenna impedance, the discriminators produce error signals outputs to fine adjust the tuning elements. Therefore, a tune condition is always maintained. While fine tuning, internal clamps in the logic circuits prevent motor-on signals from activating the home and tune logic circuits. If interference from an adjacent transmitter is evident either by a high reflected power (false) or by blinking of the READY or TUNING lamps, the coupler should be switched to MANUAL mode after the AUTOMATIC cycle is completed.

#### 4-26. MANUAL TUNING CYCLE.

4-27. Manual tuning is accomplished by the operator with the C-3698/URA-38 front panel controls. The transmitter power output must be reduced to between 50 and 250 watts, and the system must be keyed by the operator. During this mode of operation, the outputs from the discriminators are switched one at a time to the DISCRIMINATOR NULL meter, as determined by the setting of the L-C switch. The selected tuning element is adjusted by depressing the LEFT or RIGHT pushbutton as required to provide a null indication on the DISCRIMINATOR NULL meter. The elements are alternately adjusted until a null indication is obtained on the DISCRIMINATOR NULL meter for both the L and the C settings of the L-C switch. The servo amplifiers and most of the logic circuitry are disabled during manual operation. However, the key interlock circuit is maintained so that if an element is run up against its far end stop, RF power will be removed from the CU-938/URA-38, precluding possible damage to the equipment.

#### 4-28. SILENT TUNING CYCLE.

4-29. Initial silent tuning is accomplished without using RF power. Therefore, the discriminators, DISCRIMINATOR NULL meter, servo amplifiers, and logic circuits are not used at this time. Each tuning element is set to a prerecorded indication on the ELEMENT POSITION meter using the LEFT and RIGHT pushbuttons. As in manual tuning, only one element can be positioned at a time as selected with the L-C switch. (The indications of the ELEMENT POSITION meter must have been recorded for each element at each assigned operating frequency during previous automatic or manual operation.) The ELEMENT POSITION meter indications are provided by potentiometers whose wipers are mechanically ganged to the individual tuning elements. As in manual operation, the key interlock circuit is maintained in case a tuning element is run up against its far end stop switch. When a full power transmission

is keyed in the silent mode of operation, the servo amplifiers, motor control circuits, and brake logic are energized to enable the tuning elements to be automatically fine positioned as required to maintain a tuned condition.

4-30. POWER SUPPLY AND COOLING.

4-31. The power supply in the C-3698/URA-38 produces all DC voltages required for operating the AN/URA-38. These voltages are produced from the 115 VAC, 48 to 63 or 350 to 450 CPS, single phase primary power input from the AN/URT-23(V). The DC voltages produced are -4, -2, +12.4 and + 28 volts. Primary power is applied to the cooling fan in the CU-938/URA-38 when the transmitter is keyed to circulate the nitrogen atmosphere. The fan and the CU-938/URA-38 case form a heat exchanger to transfer internally generated heat to the ambient air.

4-32. TEST DATA.

4-33. Pertinent references and applicable test data for the AN/URA-38 are:

- a. Antenna Coupler CU-938/URA-38, Schematic Diagram, Figure 5-15.
- b. Antenna Coupler Control C-3698/URA-38, Schematic Diagram, Figure 5-16.
- c. Antenna Coupler Group AN/URA-38, Logic and Power Supply, Servicing Block Diagram, Figure 4-19.
- d. Antenna Coupler Group AN/URA-38, Servo Loops and Matching Network, Servicing Block Diagram, Figure 4-20.
- e. Required Test Equipment:
  - (1) Multimeter AN/PSM-4
  - (2) Test Cable (Fabricated in accordance with paragraph 5-33)
  - (3) Electrical Dummy Load DA-242/U
  - (4) Wattmeter AN/URM-120
- f. For equipment characteristics, refer to Antenna Coupler Group AN/URA-38 Performance Standards Sheet, NAVSHIPS 0967-204-0030.
- g. Adjustments:
  - (1) Discriminator, Paragraph 5-4.
  - (2) Servo Amplifiers, Paragraph 5-10.
- h. For testing information, refer to Reference Standards Book for Antenna Coupler Group AN/URA-38, NAVSHIPS 0967-204-0040.
- i. Component and Test Point Locations:
  - (1) Antenna Coupler Control C-3698/URA-38, Chassis, Component Locations, Figure 5-8.

(2) Antenna Coupler CU-938/URA-38, Chassis, Component Locations, Figure 5-4.

(3) Antenna Coupler CU-938/URA-38, Case, Component Locations, Figure 5-3.

j. System Troubleshooting, Paragraph 4-105.

4-34. DETAILED DESCRIPTIONS.

4-35. MATCHING NETWORK.

4-36. GENERAL. The matching network (figure 4-2) consists of a transformer (T1), a variable inductor (L1), and a variable capacitor (C1). The function of these components is to transform the impedance of a system antenna to an impedance that is 50 ohms resistive.

4-37. CIRCUIT DESCRIPTION. Inductor L1 and capacitor C1 are motor driven to the exact value of capacitive and inductive reactance required for a tune condition (paragraph 4-59). Inductor L1 is adjusted to provide enough shunt loading reactance to transform the antenna impedance to an inductive impedance with an equivalent series resistive component of 22.2 ohms. Capacitor C1 is then adjusted to cancel the inductive reactance component of this impedance. Thus, the antenna impedance is transformed by capacitor C1 and inductor L1 to a purely resistive impedance of 22.2 ohms. Transformer T1 has a primary-to-secondary turns ratio of 3:2. Since impedance is transferred through a transformer proportionally to the square of the turns ratio, the input impedance of the CU-938/URA-38 (when tuned) is 50 ohms ( $9/4 \times 22.2$ ).

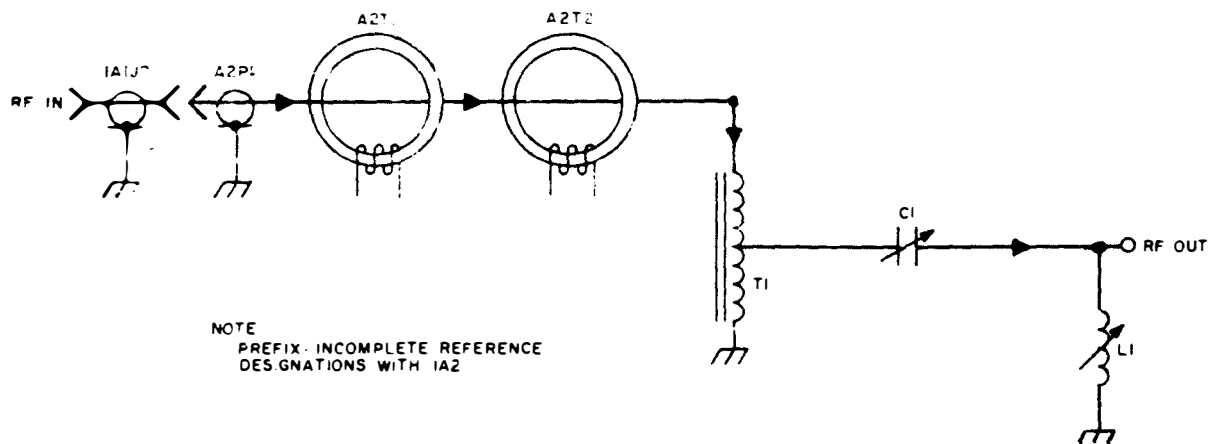

Figure 4-2. Matching Network, Simplified Schematic Diagram

4-38. Surveillance Disable Transistor. Transistor 2A1A3Q1 serves two functions. One is to disable the servo amplifiers when the transmitter is unkeyed. Secondly it controls relay 1A2K1 in the CU-938/URA-38 which in turn operates the cooling fan when the transmitter is keyed.

4-39. TEST DATA. Pertinent reference and applicable data for the matching network are:

- a. Antenna Coupler CU-938/URA-38, Schematic Diagram, Figure 5-15.
- b. Antenna Coupler CU-938/URA-38, Chassis, Component Locations, Figure 5-4.
- c. Inductor Assembly 1A2L1, Component Locations, Figure 5-7.
- d. Antenna Coupler Group AN/URA-38, Servo Loops and Matching Network, Servicing Block Diagram, Figure 4-20.
- e. Required Test Equipment:
  - (1) Multimeter AN/PSM-4
  - (2) Wattmeter AN/URM-120
  - (3) Electrical Dummy Load DA-242/U

4-40.  $\phi$  DISCRIMINATOR.

4-41. GENERAL. The function of the phase discriminator (figure 4-3) is to provide a DC output to C servo amplifier 2A1A1 indicative of the reactive component of the line impedance. This DC output will be zero when the reactive component is the desired 0 ohms, positive when the reactive component is capacitive, and negative when the reactive component is inductive.

4-42. CIRCUIT DESCRIPTION. The line current induces a voltage in transformer T1, half of this voltage across resistor R2 and half across resistor R1. Taking the junction of resistors R1 and R2 as a reference, the voltages across resistors R1 and R2 are in opposite phase, so that the voltage across resistor R2 is in phase with the line current and the voltage across resistor R1 is 180° out of phase with the line current. (It is just as if the junction of resistors R1 and R2 were connected to a center-tap on the transformer.) Divider C1-R3, R10 produces a reference voltage at the junction of resistors R1 and R2 90° out of phase with the line voltage. The vector sum of the voltage drops across resistors R3, R10 and R1 is detected by diode CR2 and filtered by capacitor C2, producing a positive DC voltage across resistor R11. The vector sum of the voltages across resistors R3, R10 and R2 is detected by diode CR1 and filtered by capacitor C3, producing a negative DC voltage across resistor R12. The two DC voltages are summed through resistors R4, R5, and R6 and applied through pin A of connector 1A1J1 to one side of the differential amplifier input of C servo amplifier 2A1A1. If the reactive component of the line impedance is zero, then the line voltage and line current will be in phase. In this case, the voltages at the transformer terminals will be equal in amplitude, and thus the two DC voltages will also be equal (one positive, the other negative). Summing two equal and opposite DC voltages results in zero output, indicating that the variable capacitor is tuned. If the reactive component of the line impedance is other than zero, the line voltage and current will no longer be in phase and so the AC voltages (across resistors R3, R10 and R1 or R2) will no longer be equal. Therefore, the DC voltage

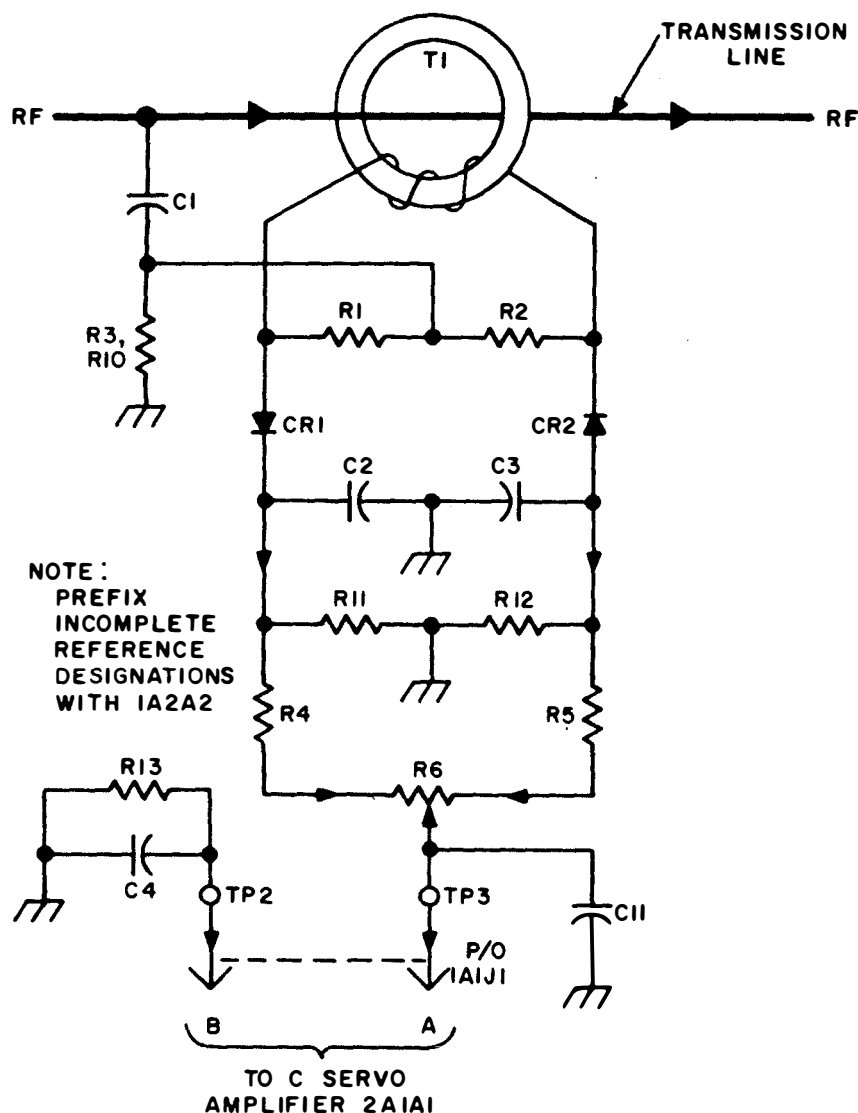

Figure 4-3.  $\emptyset$  Discriminator, Simplified Schematic Diagram

outputs from diodes CR1 and CR2 must also be unequal, resulting in either a positive (for capacitive reactance) or a negative (for inductive reactance) error signal output to C servo amplifier 2A1A1 to correct the adjustment of the variable capacitor.

4-43. The error signal described above is applied to one side of a differential amplifier in C servo amplifier 2A1A1. The other side of the differential amplifier input is connected to ground through resistor R13. Resistor R13 is used instead of a short circuit to ground so that both sides of the differential amplifier will have the same impedance. This resistor is located in the discriminator assembly rather than the C servo amplifier assembly so that both sides of the differential amplifier will have the same length of lead, and therefore, the same amount of any stray hum or noise pickup. Since a differential amplifier responds only to differences in signal level between its two inputs, hum or noise signals present equally at both inputs will not be amplified. Capacitors C4 and C11 are RF bypasses. Potentiometer R6 is adjusted to provide a zero DC output from the  $\emptyset$  discriminator when the line



voltage and current are in phase (zero reactive component in the line impedance), thus compensating for any unbalance in the discriminator caused by component tolerances.

4-44. TEST DATA. Pertinent references and applicable data for the  $\emptyset$  discriminator are:

- a. Antenna Coupler CU-938/URA-38, Schematic Diagram, Figure 5-15.
- b. Discriminator Assembly 1A2A2, Component and Test Point Locations, Figure 5-5.
- c. Antenna Coupler Group AN/URA-38, Servo Loops and Matching Network, Servicing Block Diagram, Figure 4-20.
- d. Discriminator Adjustment Procedures, Paragraph 5-4.
- e. Required Test Equipment:
  - (1) Multimeter AN/PSM-4
  - (2) Test Cable (Fabricated in accordance with paragraph 5-33)

4-45. R DISCRIMINATOR.

4-46. GENERAL. The function of the R discriminator (figure 4-4) is to provide a DC output to L servo amplifier 2A1A2 indicative of the resistive component of the line impedance. This DC output will be zero when the resistive component is the desired 50 ohms, positive when the resistive component is less than 50 ohms, and negative when the resistive component is greater than 50 ohms.

4-47. CIRCUIT DESCRIPTION. Capacitive divider C6-C7 produces an output across capacitor C7 which is in phase with and proportional to the line voltage. This voltage is detected by diode CR5 and filtered by capacitor C8, producing a positive DC voltage which is developed across resistor R14. The line current induces a voltage in transformer T2 which is connected so that when the line impedance is 50 ohms resistive, the voltage across transformer T2 is 180 degrees out of phase with and twice the amplitude of the voltage produced by divider C6-C7. The vector sum of the outputs from transformer T2 and divider C6-C7 is detected by diode CR6 and filtered by capacitor C9, producing a negative DC voltage across resistor R15. The two DC voltages are summed through resistors R16 and R17 and applied through pin D of connector 1A1J1 to one side of the differential amplifier input to L servo amplifier 2A1A2. If the resistive component of the line impedance is 50 ohms, the sum of the two DC voltages will be zero, indicating that the variable inductor is correctly tuned. If the resistive component is other than 50 ohms, the voltage induced in transformer T2 will no longer be exactly twice the voltage developed by divider C6-C7. Thus the voltages developed across resistors R14 and R15 will no longer be equal and opposite, and their sum at the junction of resistors R16 and R17 can no longer be zero. The resulting error signal (negative for a line impedance greater than 50 ohms, positive below 50 ohms) is applied to L servo amplifier 2A1A2 to correct the adjustment of the variable inductor.

4-48. Resistor R18 and capacitors C5 and C10 have the same functions as the corresponding parts in the  $\emptyset$  discriminator (paragraph 4-43). Inductor L3 provides a DC return for detectors CR5 and CR6. Resistor R7 is the load resistor for transformer T2. Resistor R9 provides detector CR5 with the same source impedance that resistor R7 provides to detector CR6, thus maintaining balance. At the high end of the operating frequency range, the leads of capacitor C7 produce a small amount of inductive reactance. Therefore, inductor L1 is

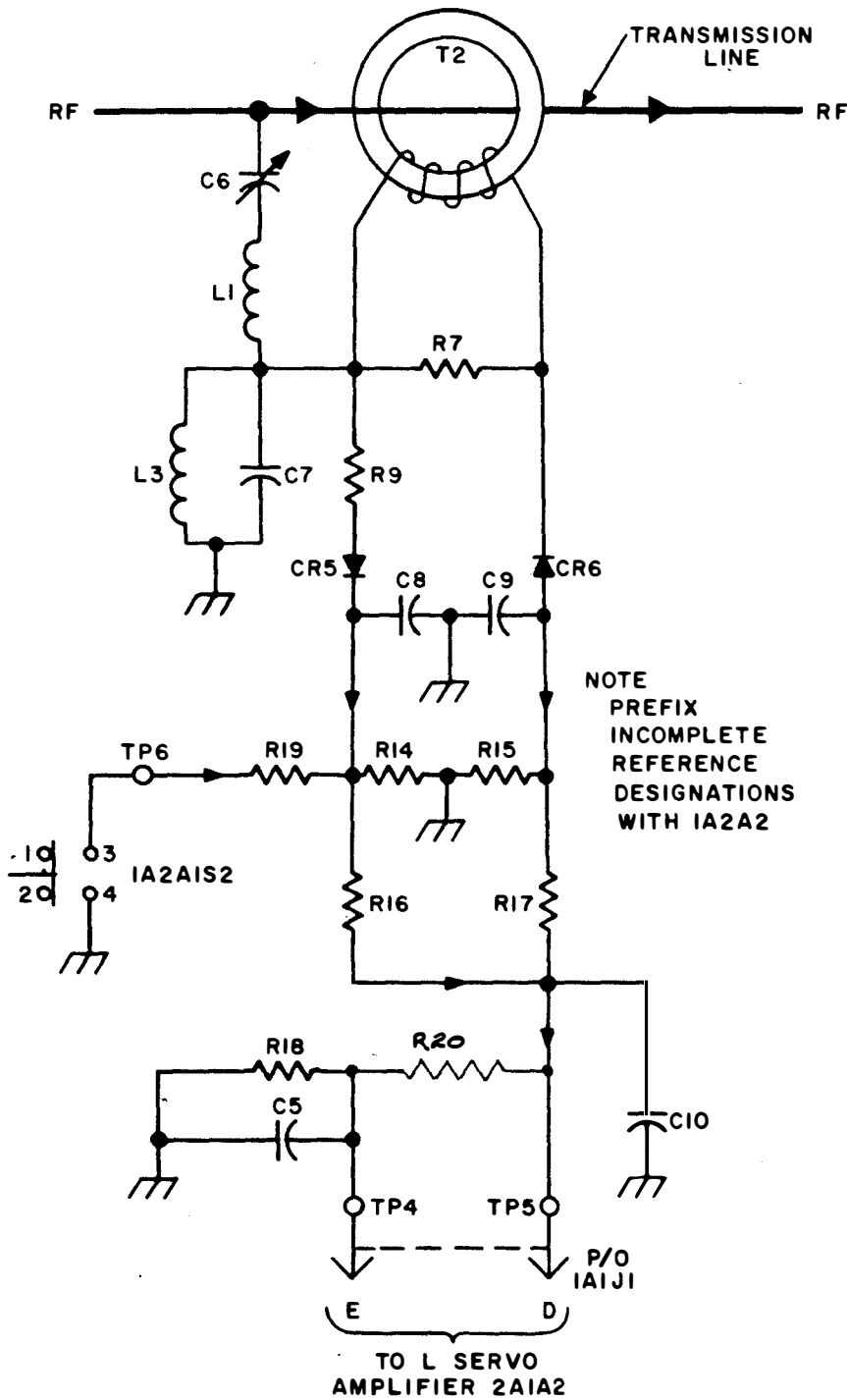

Figure 4-4. R Discriminator, Simplified Schematic Diagram

used to provide a corresponding amount of inductive reactance in series with capacitor C6 so that the output from divider C6-C7 will be frequency insensitive. Capacitor C6 is adjusted so that the voltage output from divider C6-C7 will be exactly half of that developed across transformer T2 when the line impedance is 50 ohms resistive.

4-49. FORCING. At the low end of the operating frequency range, the variable capacitor in the home position (the maximum capacitance position from which tuning is started) appears as a high impedance load to the line. This condition produces a high RF line voltage and low RF line current. Therefore, essentially no voltage is induced in the toroidal transformer of either discriminator. The voltage divider in each discriminator then becomes the only source for both detectors in each discriminator. Thus, both discriminators will produce zero output, falsely indicating that the tuning elements are properly adjusted. To prevent this condition, the variable capacitor's home end stop switch is used to connect resistor R19 in parallel with R14 in the R discriminator. This unbalances the R discriminator, producing an error signal which forces the variable inductor to be adjusted. This forcing is continued until the line impedance changes sufficiently to provide an output from the  $\theta$  discriminator. At this time, the variable capacitor will begin to tune, opening the home end stop switch to remove unbalancing resistor R19 from the R discriminator. Normal tuning then continues to adjust both tuning elements to a correct position.

4-50. TEST DATA. Pertinent references and applicable data for the R discriminator are:

- a. Antenna Coupler CU-938/URA-38, Schematic Diagram, Figure 5-15.
- b. Discriminator Assembly 1A2A2, Component and Test Point Locations, Figure 5-5.
- c. Antenna Coupler Group AN/URA-38, Servo Loops and Matching Network, Servicing Block Diagram, Figure 4-20.
- d. Discriminator Adjustment Procedures, Paragraph 5-4.
- e. Required Test Equipment:
  - (1) Multimeter AN/PSM-4
  - (2) Test cable. (Fabricated in accordance with paragraph 5-33)

4-51. SERVO AMPLIFIER.

4-52. GENERAL. The servo amplifier (figure 4-5) consists of a differential amplifier (Q3, Q5), a cross-coupled amplifier (Q4, Q6), four drivers (Q1, Q2, Q7, Q8) and two capacitor discharge transistors (Q9, Q10). The function of these circuits is to provide either a home or a tune output to the respective motor control circuit during automatic or silent operation. The servo amplifiers are not used during manual operation and are used only for fine adjustments during silent operation (paragraph 4-68).

4-53. CIRCUIT DESCRIPTION. The DC output from the discriminator is applied through switch 2A1S1 (paragraphs 4-65 through 4-71) to the base of transistor Q5. The other input to the differential amplifier, the base of transistor Q3, is tied to ground through a resistor in the discriminator. The emitters of transistors Q3 and Q5 are returned to -4 VDC. Therefore, both transistors are conducting all the time. The polarity of the discriminator output determines which of the two transistors in the differential amplifier will conduct the most, and therefore, which side of the cross coupled amplifier will turn on.

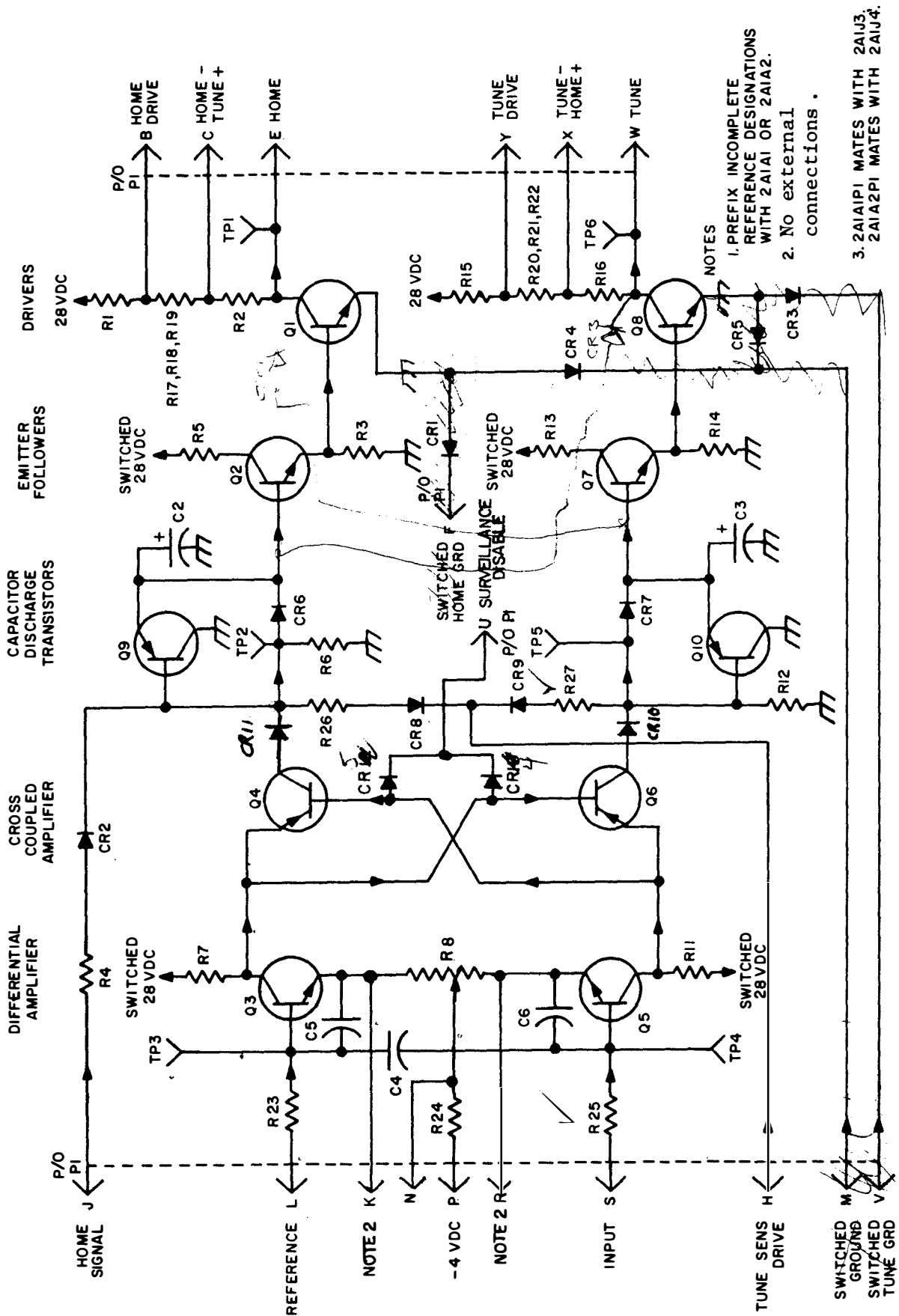

NOTES  
 1. PREFIX INCOMPLETE REFERENCE DESIGNATIONS WITH 2A1A1 OR 2A1A2.  
 2. No external connections.  
 3. 2A1A1PI MATES WITH 2A1J3. 2A1A2PI MATES WITH 2A1J4.

Figure 4-5. Servo Amplifier, Simplified Schematic Diagram

4-54. Assume that the polarity of the discriminator output is negative. This condition turns on transistor Q3 harder than transistor Q5. Therefore, transistor Q6 in the cross-coupled amplifier becomes forward biased and transistor Q4 becomes reverse biased. The output from transistor Q6 turns on transistor Q7 which turns on transistor Q8. Transistor Q8 will conduct into saturation, grounding the tune line input to the motor control circuit. Similarly, if the assumed polarity of the discriminator output had been positive, transistors Q5, Q4, Q2, and Q1 would have energized and applied a ground to the home input line to the motor control circuit. Thus, the servo amplifier responds to either polarity of discriminator output by grounding the appropriate input to the motor control circuit.

4-55. Capacitors C2 and C3 serve as audio bypasses for cross-coupled amplifiers Q4 and Q6, respectively. They prevent the servo motors from trying to follow voice modulation. Transistors Q9 and Q10 rapidly discharge the capacitors when the discriminator error signals drop to zero at the tune point; otherwise, the charge stored in the capacitors would cause the motors to run past the tune point. So long as the output from the cross coupled amplifier is positive, the diode (CR6 or CR7) is forward biased, keeping the transistors cut off. When the cross-coupled amplifier output drops to zero, resistor R12 or R6 pulls the base towards ground, turning the transistor on and thus quickly discharging the capacitor.

4-56. Resistor 2A1A1R8 or 2A1A2R8 is used to balance the differential amplifier. Resistor 2A1R9 provides the C servo amplifier with increased sensitivity. Capacitors C4, C5, and C6 are RF bypasses. During low power tuning, resistors R12 and R6 are the loads for the cross-coupled amplifier. When fine tuning at high power, the tune logic (paragraph 4-86) grounds the cathodes of diodes CR9 and CR8 thus connecting resistor R27 in parallel with R12 and R26 in parallel with R6. This reduces the sensitivity of the servo amplifier during high power operation when the discriminator produces larger output levels. The ground required to terminate the emitter of transistor Q8 is applied through diode CR5 and switch 2A1S1 during automatic operation and through diode CR3 and switches 2A1S5, 2A1S6, and 2A1S1 during silent operation (paragraphs 4-67 and 4-68). Similarly, the emitter of transistor Q1 is connected to ground through diode CR4 or CR1.

4-57. At the onset of an automatic tuning cycle, the logic circuits provide a positive level through resistor R4 and diode CR2 to the base of transistor Q2 (paragraph 4-74). This forces transistors Q2 and Q1 on to produce a home ground output to the motor control circuits. Thus, the servo motors are energized to set the tuning elements to home (a predetermined starting position for starting the tune cycle).

4-58. TEST DATA. Pertinent references and applicable data for the servo amplifier are:

- a. Antenna Coupler Control C-3698/URA-38, Schematic Diagram, Figure 5-16.
- b. Printed Circuit Boards 2A1A1 and 2A1A2, Component and Test Point Locations, Figure 5-9.
- c. Antenna Coupler Group AN/URA-38, Servo Loops and Matching Network, Servicing Block Diagram, Figure 4-20.
- d. Servo Amplifier Adjustment Procedure, Paragraph 5-10.
- e. Transistor Voltage Measurements, Paragraph 5-39.

f. Required Test Equipment:

- (1) Multimeter AN/PSM-4
- (2) PC Board Extender, Paragraph 5-31

4-59. MOTOR CONTROL CIRCUIT.

4-60. GENERAL. Each motor control circuit (figure 4-6) consists of four drivers, a servo motor, two end stop switches, and various diode gates. With the exception of reference designations and connections, two identical motor control circuits are used: one in the L servo loop and one in the C servo loop. The circuit components are located partly in the C-3698/URA-38 and partly in the CU-938/URA-38. Intercircuit and interunit connection details are explained paragraphs 4-65 through 4-71. The function of these circuits is to turn on the servo motors with the correct polarity to run them in the desired direction. Reference designations used in the following discussion are for the C motor control circuit.

4-61. CIRCUIT DESCRIPTION. If we wish to energize the C servo motor for a tune direction of rotation, the tune output from the C servo amplifier will be at ground, applying the ground to the base of transistor Q5. This ground turns transistor Q5 on, resulting in the application of ground to terminal 1 of C servo motor 1A2A1B1. This ground is also applied through diode 1A2A1CR5 to energize the brake logic (paragraph 4-78) to release the motor brake. Turning transistor Q5 on also grounds the bottom of voltage divider A1R15-R20-R21-R22, causing transistor Q2 to conduct. Therefore, 28 VDC is applied through transistor Q2 and diode 1A2A1CR1 to terminal 2 of C servo motor 1A2A1B1. This establishes current flow through the servo motor in the correct polarity for a tune direction of rotation.

4-62. If the home direction of rotation is needed, the C servo amplifier output grounds the base of transistor Q6. Therefore, ground is applied to terminal 2 of C servo motor 1A2A1B1 and through diode 1A2A1CR6 to the brake logic. Transistor Q1 is energized by voltage divider A1R1-R17-R18-R19 to apply 28 VDC to terminal 1 of C servo motor 1A2A1B1. This produces current flow through the servo motor with the correct polarity for a home direction of rotation.

4-63. Home end stop switch 1A2A1S2 (1A2A3S2 for the L servo motor) and far end stop switch 1A2A1S1 (1A2A3S1 for the L servo motor) serve as limit switches to stop the motors and protect the tuning elements from being driven too far. They also provide signals to the logic circuits indicating that the home or far end positions have been reached. For example, initiating a tuning cycle causes the servo motors to drive the tuning elements to their home positions (maximum capacitance and minimum inductance). When the elements reach home, the normally closed contacts of end stop switches 1A2A1S2 and 1A2A3S2 open, de-energizing the servo motors. The normally open contacts of these end stop switches now close, applying the reset signal (ground) to the tune and ready light logic (paragraphs 4-80 and 4-88) and the forcing signal (ground) to the R discriminator (paragraph 4-45). On the other hand, if a tuning element is driven up against its far end stop (end opposite home), it opens the normally closed contacts of its far end stop switch (1A2A1S1 or 1A2A3S1), de-energizing the motor. In addition, the normally open contacts of the switch close, applying the far end stop signal (ground) to the keying and ready light logic (paragraphs 4-84 and 4-88) to remove RF power and extinguish the READY light. (RF power is removed because reaching a far end stop is an abnormal condition occurring only with a damaged antenna or inability to tune properly.)

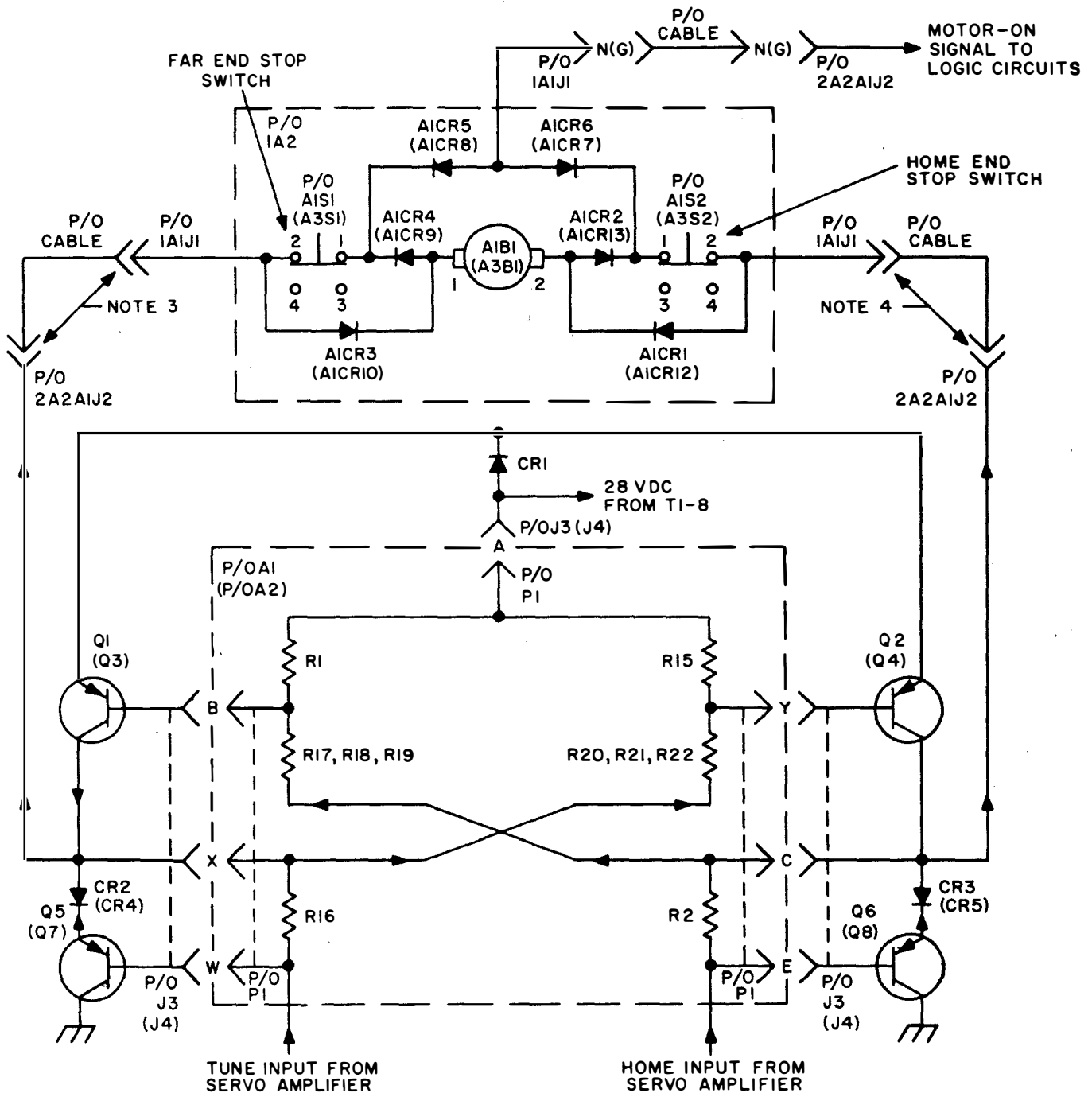

NOTES:

1. PREFIX INCOMPLETE REFERENCE DESIGNATIONS WITH 2AI.
2. REFERENCE DESIGNATIONS IN PARENTHESES ARE FOR L-MOTOR CONTROL; OTHERS ARE FOR C-MOTOR CONTROL.
3. PINS H,J,K,U FOR C-MOTOR CONTROL; V, W FOR L-MOTOR CONTROL.
4. PINS P,R,S,c FOR C-MOTOR CONTROL; a, b FOR L-MOTOR CONTROL.

Figure 4-6. Motor Control, Simplified Schematic Diagram

4-64. TEST DATA. Pertinent references and applicable data for the motor control circuit are:

- a. Antenna Coupler CU-938/URA-38, Schematic Diagram, Figure 5-15.
- b. Printed Circuit Boards 2A1A1 and 2A1A2, Component and Test Point Locations, Figure 5-9.
- c. Antenna Coupler Control C-3698/URA-38, Schematic Diagram, Figure 5-16.
- d. Antenna Coupler Control C-3698/URA-38, Component Locations, Figure 5-8.
- e. Antenna Coupler CU-938/URA-38, Chassis, Component Locations, Figure 5-4.
- f. Antenna Coupler Group AN/URA-38, Servo Loops and Matching Network, Servicing Block Diagram, Figure 4-20.
- g. Transistor Voltage Measurements, Paragraph 5-39.
- h. Required Test Equipment:
  - (1) Multimeter AN/PSM-4
  - (2) PC Board Extender, Paragraph 5-31.

4-65. C SERVO LOOP SWITCHING AND METERING.

4-66. GENERAL. The C servo loop switching and metering circuitry (figure 4-7) provides switching and metering to allow variable capacitor 1A2C1 to be adjusted automatically or manually according to the mode of operation.

4-67. AUTOMATIC OPERATION. During automatic operation, Mode Selector switch S1 provides all the necessary switching. (The tuning cycle is completely automatic.) The input from the  $\theta$  discriminator is applied through pin A of connector 2A2A1J2, contacts 11 and 12 of S1-rear, and pin S of connector J3 to servo amplifier A1. The  $\theta$  discriminator reference is applied through pin B of connector 2A2A1J2, contacts 4 and 5 of S1-front, and pin L of connector J3. The ground for terminating the emitters of transistors Q1 and Q8 in servo amplifier A1 is applied through contacts 1 and 2 of S1-front, pin M of connectors J3 and A1P1, and diodes A1CR4 and A1CR5, respectively. (During this mode of operation, pushbuttons S5 and S6 are disabled by breaking the ground path through contacts 1 and 12 of S1-front. This avoids the possibility that accidentally depressing one of the pushbuttons while the set was automatically tuning could cause both a home and a tune output to be supplied to the motor control circuit at the same time.)

4-68. SILENT OPERATION. Silent operation allows variable capacitor 1A2C1 to be pre-positioned without the use of RF power. During automatic or manual operation, the indication of ELEMENT POSITION meter M1 should be recorded for each allocated operating channel. Variable capacitor 1A2C1 can then be adjusted (in Silent mode) for each operating channel without using RF power by setting the L-C switch at C and depressing the LEFT and RIGHT pushbuttons as required until the ELEMENT POSITION meter indicates the pre-recorded position for that channel. Depressing LEFT pushbutton S5 connects ground through contacts 1 and 12 of S1-front, normally closed contacts 1 and 2 of S6, normally open contacts 4 and 3 of S5, and contacts 3 and 4 of S3-front to the home input to the C motor control circuit. Depressing RIGHT pushbutton S6 applies ground through contacts 1 and 12 of



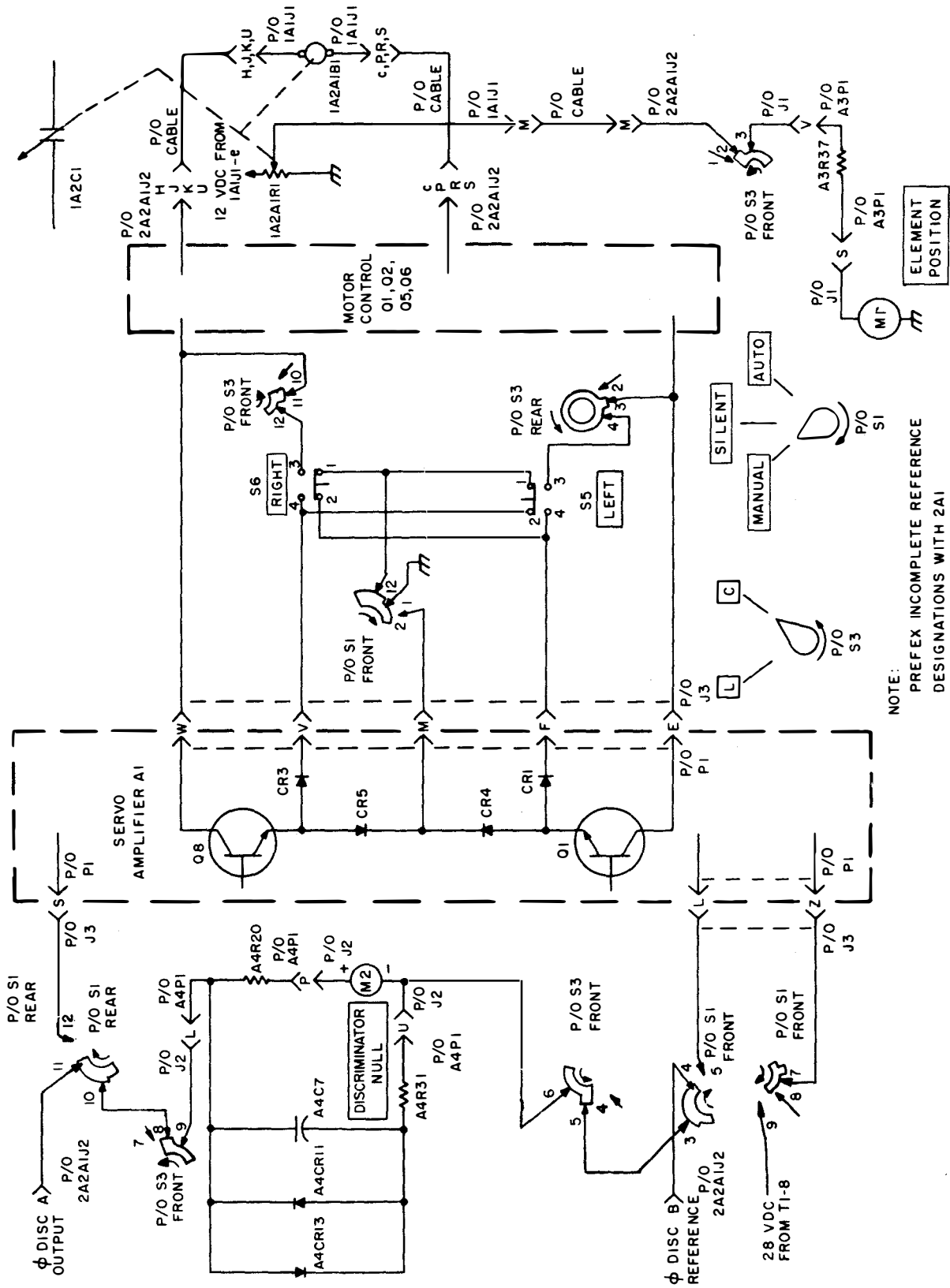

Figure 4-7. C Servo Loop, Simplified Switching and Metering Diagram

S1-front, normally closed contacts 1 and 2 of S5, normally open contacts 4 and 3 of S6, and contacts 12 and 11 of S3-rear to the tune input to the C motor control circuit. Therefore, depressing a pushbutton energizes servo motor 1A2A1B1 in either a home or tune direction of rotation. As the motor adjusts capacitor 1A2C1, the setting of potentiometer 1A2A1R1 is also changed. This varies the amount of voltage applied through pin M of connector 1A1J1, the interconnecting cable, pin M of connector 2A2A1J2, contacts 2 and 3 of S3-front, pin V of connectors J1 and A3P1, resistor A3R37, and pin S of connectors A3P1 and J1 to ELEMENT POSITION meter M1. Thus, ELEMENT POSITION meter M1 provides an indication of element position, allowing the element to be preset to any desired position. When the transmitter is keyed, variable capacitor 1A2C1 is automatically fine-tuned as required to compensate for tuning errors. The required connections are as follows: The output and reference leads from the  $\phi$  discriminator are applied to servo amplifier A1 through contacts 11 and 12 of S1-rear and contacts 4 and 5 of S1-front, respectively. Ground for terminating the emitter of transistor A1Q8 is applied through contacts 1 and 12 of S1-front, normally closed contacts 1 and 2 of S5, pin V of connectors J3 and A1P1, and diode A1CR3. Ground for terminating the emitter of transistor A1Q1 is applied through contacts 1 and 12 of S1-front, normally closed contacts 1 and 2 of S6, pin F of connectors J3 and A1P1, and diode A1CR1. The ground path for the emitter of each transistor passes through the contacts of that pushbutton which causes rotation in a direction opposite to that produced when the transistor is turned on. This interlocks the home and tune lines so that accidental depressing of a pushbutton can not cause both a home and a tune input to be applied to the motor control circuit at the same time during fine-tuning. Similarly, this interlock prevents accidental keying of the transmitter from causing a home and a tune output from being applied to the motor control circuit at the same time while rough positioning with the pushbuttons.

4-69. MANUAL OPERATION. Manual operation allows variable capacitor 1A2C1 to be adjusted if a failure occurs in the logic or servo amplifier circuits, or when the AN/URA-38 is being used with a transmitter other than the AN/URT-23(V). When the Mode Selector switch is set at MANUAL and the L-C switch is set at C, the  $\phi$  discriminator output is connected through contacts 11 and 10 of S1-rear, contacts 8 and 9 of S3-front, pin L of connectors J2 and A4P1, resistor A4R20, and pin P of connectors A4P1 and J2 to one side of DISCRIMINATOR NULL meter M2. The  $\phi$  discriminator reference lead is connected through contacts 4 and 3 of S1-front, and contacts 5 and 6 of S3-front to the other side of DISCRIMINATOR NULL meter M2. When the transmitter is keyed, DISCRIMINATOR NULL meter M2 provides a relative indication of the polarity and magnitude of the discriminator error signal. Using this indication as a guide, the servo motor can be energized using the pushbuttons (as was explained for silent operation) to position capacitor 1A2C1 to obtain a null indication on DISCRIMINATOR NULL meter M2. The magnitude of the error signal applied to DISCRIMINATOR NULL meter M2 is limited by diodes A4CR13 and A4CR11 to prevent damage to the meter. Capacitor A4C7 is an RF bypass. During automatic and silent operation, 28 VDC for energizing servo amplifier A1 is applied through contacts 9 and 7 of S1-front and pin Z of connectors J3 and A1P1. During manual operation, the servo amplifier is not used, and thus, the 28 VDC is not supplied.

4-70. L SERVO LOOP SWITCHING AND METERING.

4-71. GENERAL. The L servo loop switching and metering circuitry (figure 4-8) provides switching and metering to allow variable inductor 1A2L1 to be adjusted automatically or manually according to the mode of operation. These circuits are identical to those used in the C servo loop, with the exception of switch contacts and connector pins.

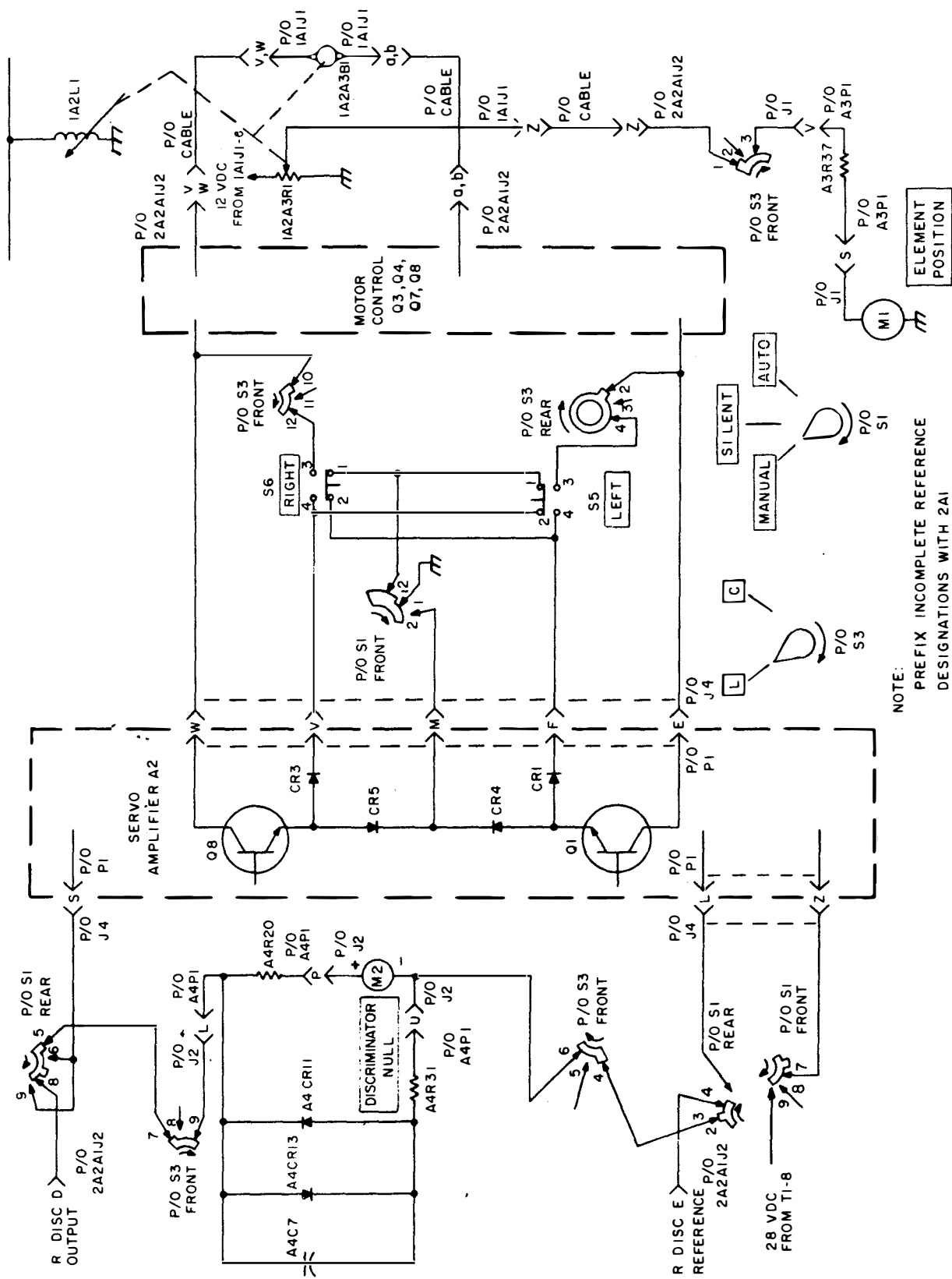

Figure 4-8. L Servo Loop, Simplified Switching and Metering Diagram

#### 4-72. LOGIC CIRCUITS.

4-73. GENERAL. The logic circuits provide the necessary control signals in the proper sequence to automatically position the tuning elements for any selected operating channel. These circuits are basically all located in the C-3698/URA-38 with the exception of the end stop switches which are located in the CU-938/URA-38. The AN/URA-38 protection circuits are also included in the logic to interrupt the tuning cycle and/or inhibit operation if a malfunction or overload develops. Figure 4-9 illustrates, and paragraphs 4-74 through 4-90 explain the sequencing of the automatic tuning cycle.

4-74. HOME LOGIC CIRCUIT DESCRIPTION. The home logic (figure 4-10) consists of two inverters (Q1 and Q2) and a clamp (CR2) which function as a flip-flop. This circuit is used only during the automatic or silent modes of operation. When a home cycle is initiated, this circuit produces the necessary output to drive the tuning elements home (that is to the predetermined starting position). A home cycle is initiated by turning the primary power on, changing the T-827/URT operating frequency, or depressing the RETUNE switch, or by recovery from power loss, all as described below. Applying primary power results in the base of transistor Q2 momentarily being pulled to ground by capacitor C3. When the T-827/URT operating frequency is changed, a ground pulse is applied through pin E of connector 2A2A1J1, feedthru capacitor 2A2A1C1, RF suppression filter 2A2A1C8 and 2A1L1, and pin C of connectors 2A1J2 and P1 to the base of transistor Q2. Depressing the RETUNE switch, and changing frequency 1 KC also produce a momentary ground pulse at the base of transistor Q2. Therefore, in each of these conditions, the base of transistor Q2 is (momentarily) grounded, forcing transistor Q2 off, if it was on. When transistor Q2 is off, the positive level at its collector (the "home signal") is applied to the servo amplifiers to energize the servo motors to drive the tuning elements home (paragraph 4-57). In addition, the home signal is applied to the keying logic to prevent the system from being keyed during the home cycle (paragraph 4-85). When the motors energize, the motor-on logic is turned on (paragraph 4-76), applying a positive level through pin J of connectors 2A1J2 and P1 and resistors R5 and R6 to the base of transistor Q1. This turns on transistor Q1, grounding the base of transistor Q2. Therefore, transistor Q2 and the ready light logic (paragraph 4-88) are clamped at ground until the tuning elements reach home. At this time, the servo motors de-energize (by tripping their home end stop switches), removing the positive motor-on signal from base of transistor Q1. This turns transistor Q1 off, turning transistor Q2 on through resistors R8 and R9. When transistor Q2 turns on, the base of transistor Q1 is clamped to ground through the small collector-to-emitter resistance of transistor Q2 and diode CR2. This prevents motor-on signals generated during the tuning and operating cycles from re-energizing the home logic. The positive level at the collector of transistor Q1 is now applied as the "ready light on signal" to the ready light logic (paragraph 4-89). During manual operation, the output from the home logic is inhibited by the ground applied through contacts 1 and 11 of switch 2A1S1-front. Capacitor C9 is an RF bypass.

4-75. MOTOR-ON LOGIC CIRCUIT DESCRIPTION. The motor-on logic (figure 4-11) consists of a driver (Q9), and inverter (Q3), and various gates. The function of this circuit is to generate a positive level for application to the keying logic (paragraph 4-86), tune logic (paragraph 4-82), and home logic (paragraph 4-74) whenever either or both of the servo motors have an energizing voltage applied. This circuit is used only during automatic and silent operation.

4-76. When the servo motors are not energized, Zener diode VR4 conducts through resistors R35, R36, and R10. This forward biases transistor Q9, turning on transistor Q3. The collector of transistor Q3 will effectively go to ground, removing the positive level from the keying, tune, and home logic circuits. The two inputs to the motor-on logic are also the inputs to the brake logic; they come from the motor control circuits in the form of

1. Tuning cycle is initiated by:	<ul style="list-style-type: none"> <li>a. Setting POWER switch at ON.</li> <li>b. Disturbing the setting of the T-827/URT 1 KC control or either of the MCS controls.</li> <li>c. Depressing the RETUNE pushbutton.</li> </ul>
2. Home logic activates, energizing:	<ul style="list-style-type: none"> <li>a. Servo motors (toward home).</li> <li>b. Keyline interlock.</li> </ul>
3. When tuning elements reach home:	<ul style="list-style-type: none"> <li>a. Servo motors are de-energized.</li> <li>b. Reset signal is generated.</li> <li>c. Keyline remains interlocked.</li> </ul>
4. Reset signal generated above energizes:	<ul style="list-style-type: none"> <li>a. Tune power signal to transmitter.</li> <li>b. Tune sensitivity drive signal to servo amplifiers.</li> </ul>
5. Cycle halts at this point until transmitter is keyed.	
6. Keying transmitter causes release of keyline interlock, allowing transmitter to supply RF to the AN/URA-38.	
7. RF through discriminators results in discriminator error signal outputs which energize servo amplifiers, motor control circuits, and servo motors.	
8. Energizing servo motor(s) produces a motor-on signal(s).	
9. Motor-on signal(s)	<ul style="list-style-type: none"> <li>a. Locks system in keyed condition.</li> <li>b. Locks on tune sensitivity drive signal to servo amplifiers.</li> <li>c. Locks on tune power signal to transmitter.</li> </ul>
10. When tuning elements have reached a tune position:	<ul style="list-style-type: none"> <li>a. Servo motors de-energize.</li> <li>b. System key is released.</li> <li>c. Tune sensitivity drive signal is removed from servo amplifiers.</li> <li>d. Tune power signal is removed from transmitter.</li> <li>e. READY light is energized.</li> </ul>
11. System is tuned and ready for full power operation. Fine tuning will be accomplished as required during the transmission.	

Figure 4-9. Antenna Coupler Group AN/URA-38, Automatic Tuning Sequence Diagram

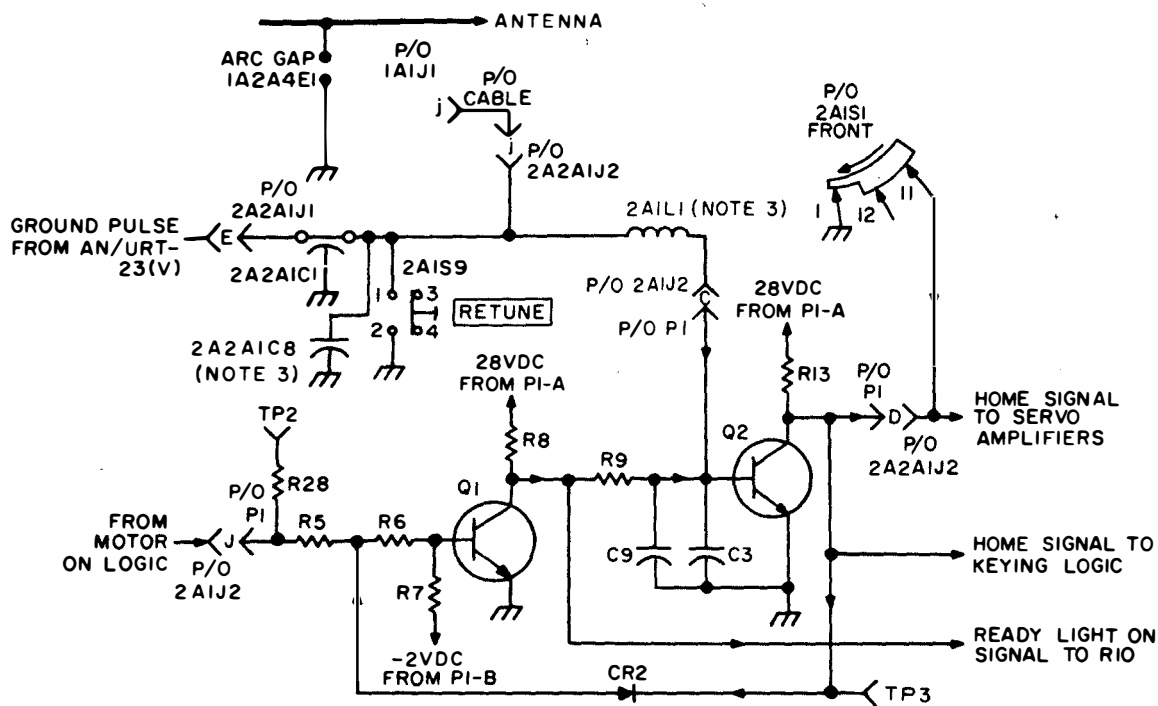

NOTE :

1. PREFIX INCOMPLETE REFERENCE DESIGNATIONS WITH 2A1A4.
2. SWITCH 2A1S1 SHOWN IN MANUAL POSITION.
3. 2A2L1 AND 2A1 ARE NOT INCLUDED IN UNITS WITH SERIAL NUMBERS A1 THROUGH A130 AND A132 THROUGH A144

Figure 4-10. Home Logic, Simplified Schematic Diagram

a ground whenever a servo motor is energized (paragraphs 4-46 and 4-62). This ground is applied through diode CR3 and/or diode CR2 and diode CR12 to the junction of resistors R36 and R10. This turns Zener diode VR4 and transistors Q9 and Q3 off, allowing the voltage at the collector of transistor Q3 to go positive. This positive level is then applied as the "motor-on signal" to the home, keying, and tune logic circuits. Zener diode VR4 is included to ensure proper cut-off of transistor Q9, since the L- and C-motor-on grounds do not actually go all the way to ground, but remain 3 to 4 volts positive because of the diode junction drops in the motor control circuits. Since this is less than the 6.2 volt drop of VR4, the Zener diode will not conduct, forcing transistor Q9 off. Capacitor C2 and resistor R10 delay the turn-on of transistor Q9 for a short time when the motors de-energize, thus preventing the motor-on signal from de-energizing when the motors repeatedly reverse direction of rotation while approaching the tune point. This assures that the home logic and tune logic circuits do not become locked off prematurely, before the actual tune point is reached (paragraphs 4-74 and 4-86). Resistor R35 provides a discharge path for capacitor C2. Capacitor C10 is an RF bypass.

4-77. The L- and C-motor-on grounds are applied to the brake logic at the same time that they are applied to transistor Q9 to release the motor brakes (paragraph 4-79). When the motors are energized, the ground(s) used to turn off transistor Q9 are also applied through pin P of connectors P1 and 2A1J1 to TUNING indicator 2A1DS3, energizing it to provide an indication that the tuning cycle is in process.

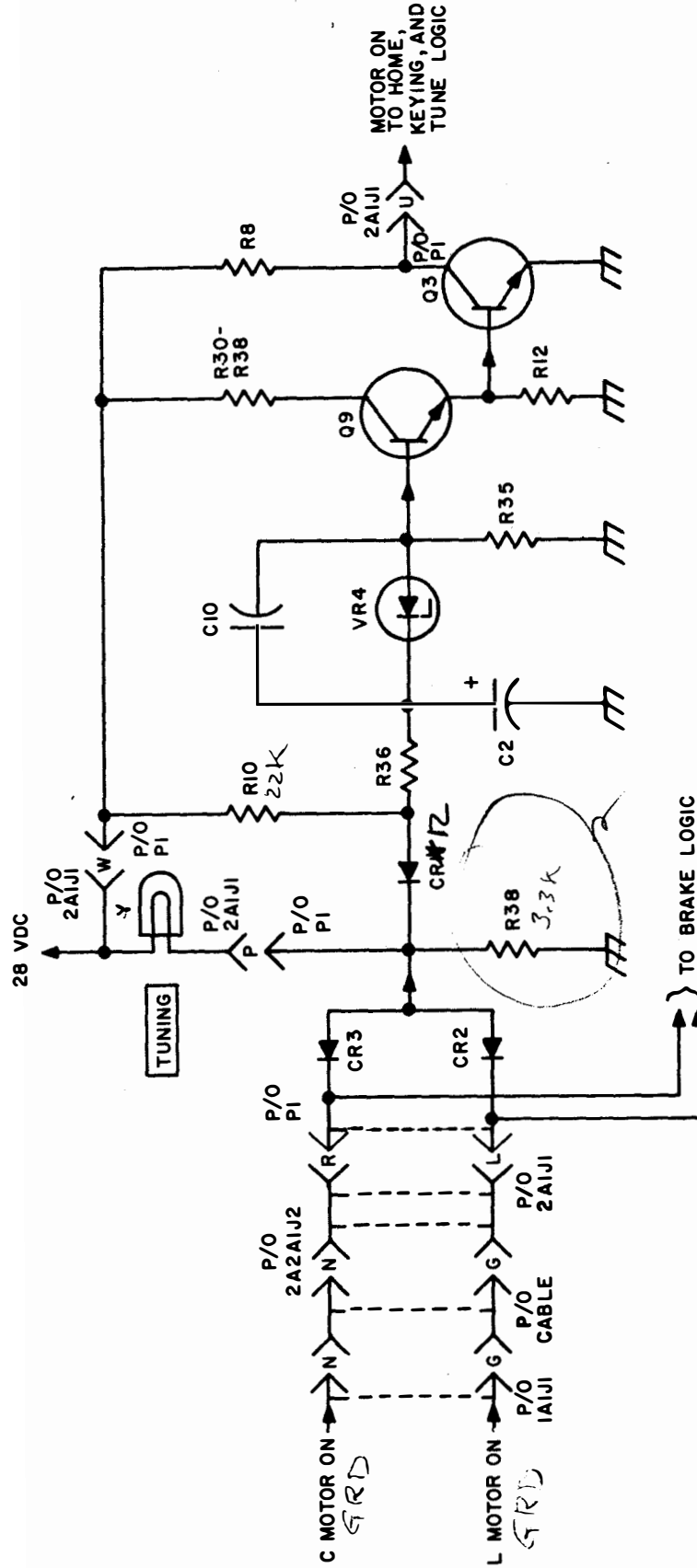

NOTE:  
PREFIX INCOMPLETE REFERENCE  
DESIGNATIONS WITH 2A1A3

Figure 4-11. Motor-On Logic, Simplified Schematic Diagram

4-78. BRAKE LOGIC CIRCUIT DESCRIPTION. The brake logic (figure 4-12) consists of two identical circuits; one for controlling the brake on servo motor 1A2A1B1, and one for controlling the brake on servo motor 1A2A3B1. In each case, the circuit consists of two inverters (Q2 and Q7) or (Q6 and Q8).

4-79. Each of the motors has a mechanical brake which releases so long as current is driven through the brake winding. The reference designations used in the discussion are for the L brake logic circuit. When L servo motor 1A2A3B1 is not energized, the L-motor-on signal is absent, thus Zener diode VR5 conducts, turning on transistor Q2. Transistor Q2 conducts into saturation, effectively causing the collector to go to ground. This ground turns off transistor Q7, preventing conduction through the motor brake winding. Therefore, the brake is engaged. When the energizing potential is applied to the motor, a motor-on ground is applied to Zener diode VR5 at the same time that it is applied to the motor-on logic (paragraph 4-76). This ground turns off Zener diode VR5 and in turn transistor Q2, allowing its collector to go positive and forward bias transistor Q7. Therefore, transistor Q7 is turned on and conducts through the motor brake winding. This current flow through the brake winding disengages the motor brake, permitting the L servo motor to rotate the variable coil tuning element. Zener diode VR5 assures that transistor Q2 is turned off by the motor-on ground signal, which is slightly above ground (as in the motor-on logic, paragraph 4-76). Resistor R9 and capacitor C9 form a transient suppressor circuit to prevent the high voltage transients produced by halting the current flow through the brake windings from damaging transistor Q7.

4-80. TUNE LOGIC CIRCUIT DESCRIPTION. The tune logic (figure 4-13) consists of two inverters (Q4 and Q5) and various other associated components. The function of this circuit is to provide (1) a "tune power signal" for application to the AN/URT-23(V) to reduce the RF power level to 200 watts while tuning, and (2) a positive "tune sensitivity drive signal" to increase the sensitivity of the servo amplifiers during the tuning cycle (paragraph 4-54). This circuit is used only during automatic operation.

4-81. When the variable inductor tuning element reaches the home position, the normally open contacts of end stop switch 1A2A3S2 close. This applies ground through pin T of connector 2A2A1S2 to pin F of connector 2A2A1J1 from which it is connected to the AN/URT-23(V) so that when the system is keyed, the RF power level will be limited to 200 watts for tuning. In addition, this "reset ground" is applied through pin K of connectors 2A1J2 and P1 to the ready light logic (paragraph 4-89). Also, the ground is applied through diode CR10 to the base circuit of transistor Q5. This turns off the normally conducting transistor Q5, resulting in the collector going positive. This positive level is applied to the servo amplifiers to increase their sensitivity (paragraph 4-54).

4-82. Therefore, since the tune power signal is applied to the AN/URT-23(V) when the variable coil tuning element reaches home, momentarily keying the system results in a reduced RF power level being applied to the CU-938/URA-38. Application of the RF power causes the discriminators to produce error signals and activate the servo loops. This energizes the motor-on logic, resulting in a positive motor-on signal being applied through pin J of connectors 2A1J2 and P1 and isolation resistor R19 to the keying logic circuit as the "key hold signal" to lock the system in a keyed condition during the tuning cycle. In addition, the motor-on signal is applied to voltage divider R22-21, forward biasing transistor Q4, causing its collector to go to ground and lock inverter Q5 off. The tune power ground and positive tune sensitivity drive signals are thus maintained until the tuning cycle is complete.



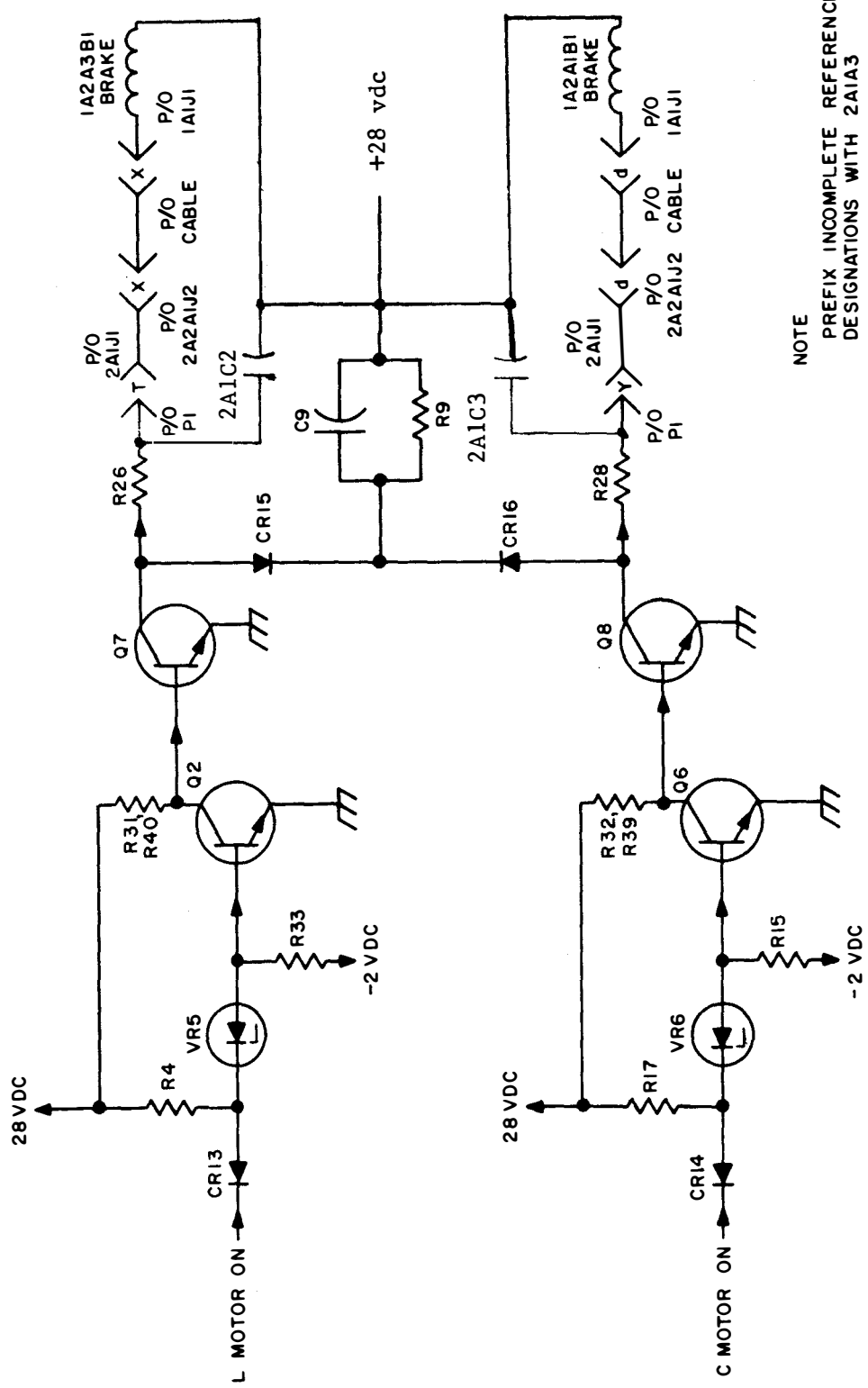

NOTE  
PREFIX INCOMPLETE REFERENCE  
DESIGNATIONS WITH 2A1A3

Figure 4-12. Brake Logic, Simplified Schematic Diagram

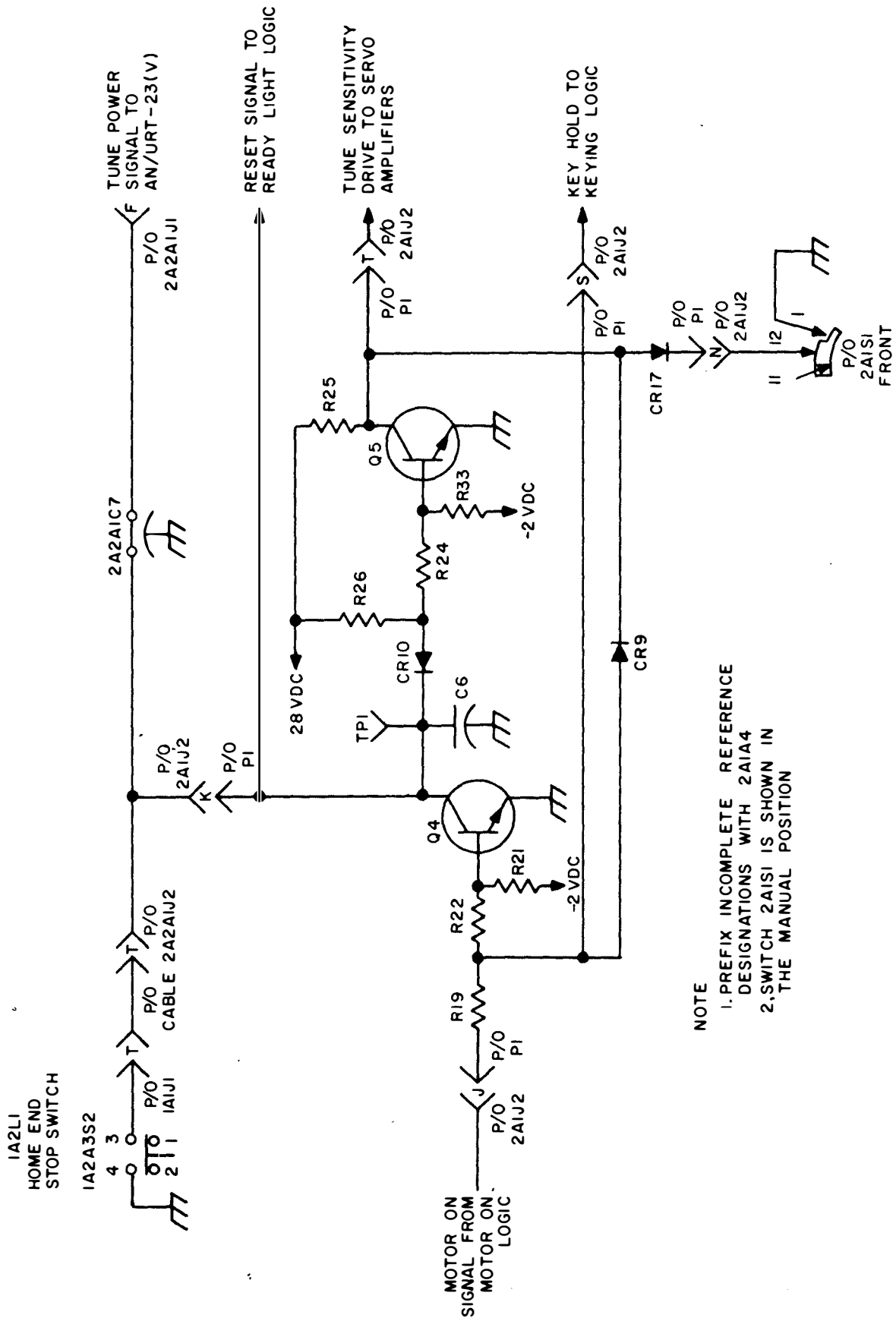

NOTE  
1. PREFIX INCOMPLETE REFERENCE DESIGNATIONS WITH 2A1A4  
2. SWITCH 2A1SI IS SHOWN IN THE MANUAL POSITION

Figure 4-13. Tune Logic, Simplified Schematic Diagram

4-83. At the completion of the tuning cycle, the servo loops de-energize, turning off transistor Q4, and turning on transistor Q5. Therefore, the tune sensitivity drive signal goes to ground and the tune power signal goes positive. The conduction of transistor Q5 also grounds the base circuit of transistor Q4 through clamping diode CR9, preventing transistor Q4 from turning on. Therefore, when the system is keyed for full power operation, motor-on signals produced by the fine tuning process will not activate the tune or keying logic circuits. During manual and silent operation, the tune and keying logic are inhibited by the ground applied through contacts 1 and 12 of switch 2A1S1-front.

4-84. KEYING LOGIC CIRCUIT DESCRIPTION. The keying logic (figure 4-14) consists of a DC amplifier (2A1A3Q4), two inverters (2A1A3Q5 and Q3), the antenna coupler pressure and temperature overload circuitry, and various other gates and parts. The functions of this circuit are (1) to interlock the keyline to prevent keying during the home cycle, (2) to hold the system keyed during the tuning cycle, and (3) to interlock the AN/URT-23(V) key circuits to prevent the system from being keyed if there is a temperature or pressure overload or if one of the tuning element is run against its far end stop. The keying portion of the circuit is used only during automatic operation. However, the interlock portion of the circuit is used in all modes of operation.

4-85. While the tuning elements are being driven home during a home cycle, the home logic (paragraph 4-74) applies a positive level through diode gate CR5 to voltage divider R17-R18. This forward biases transistor Q3, causing the collector to go to ground. When Key Interlock Disable switch 2A1S10 is set at NORMAL, this ground is applied through pin F of connectors P1 and 2A1J2, feed thru capacitor 2A2A1C5, pin J of connector 2A2A1J1, and the inter-connecting cabling to the AN/URT-23(V). This ground is used in the AN/URT-23(V) to prevent an RF output from being keyed. At the completion of the home cycle, transistor Q3 is held on by the 28 VDC applied to base voltage divider R17-R18 through resistor R15 and diodes CR6 and CR7.

4-86. When the tuning cycle is initiated by momentarily keying the system, the motor-on and tune logic circuits (paragraphs 4-74 and 4-82) provide a positive key hold signal through pin J of connectors 2A1J1 and P1 to voltage divider 2A1A3R20-R21. This positive level turns on transistor 2A1A3Q4, which in turn biases transistor 2A1A3Q5 on, causing its collector to go to ground. This ground is applied through pin K of connectors 2A1A3P1 and 2A1J1, feedthru capacitor 2A2A1C2, pin B of connector 2A2A1J1, and the interconnecting cabling to the AN/URT-23(V). Transistor 2A1A3Q5 also grounds resistor R15, removing forward bias on transistor Q3 to release the keyline interlock and permit RF power to be generated by the AN/URT-23(V). This key down condition maintains a low power RF output from the AN/URT-23(V) until the tuning cycle has been completed. At the completion of the tuning cycle, the key hold signal goes away, releasing the ground on the system keyline and reapplying the ground to the keyline interlock line. The AN/URA-38 is now ready for full power operation. The Surveillance Disable circuit (Fig 4-16) consists of a single switching circuit. The function of this circuit is to disable the Servo amplifiers (Automatic and Silent tuning) when the transmitter is unkeyed, thus preventing accidental false tuning during a period of Standby or Receive. A strong signal from a nearby transmitter on a different operating frequency could induce voltages in the CU-938/URA-38 antenna tuning network large enough to generate discriminator error signals which can cause the servos to go to some random position if the servo amplifiers were not thus interlocked with the Keyline.

4-87. If the temperature becomes excessive or the pressure decreases below rated limits, switch 1A2S1 or 1A2S4 will close and apply 28 VDC through pin f of connector 1A1J1, the interconnecting cabling, pin f of connector 2A2A1J2, pin M of connectors 2A1J2 and P1, resistor R27, and diode CR8 to the base circuit of inverter Q3. This grounds the key interlock, removing RF power until the condition is removed. In addition, the 28 VDC is applied

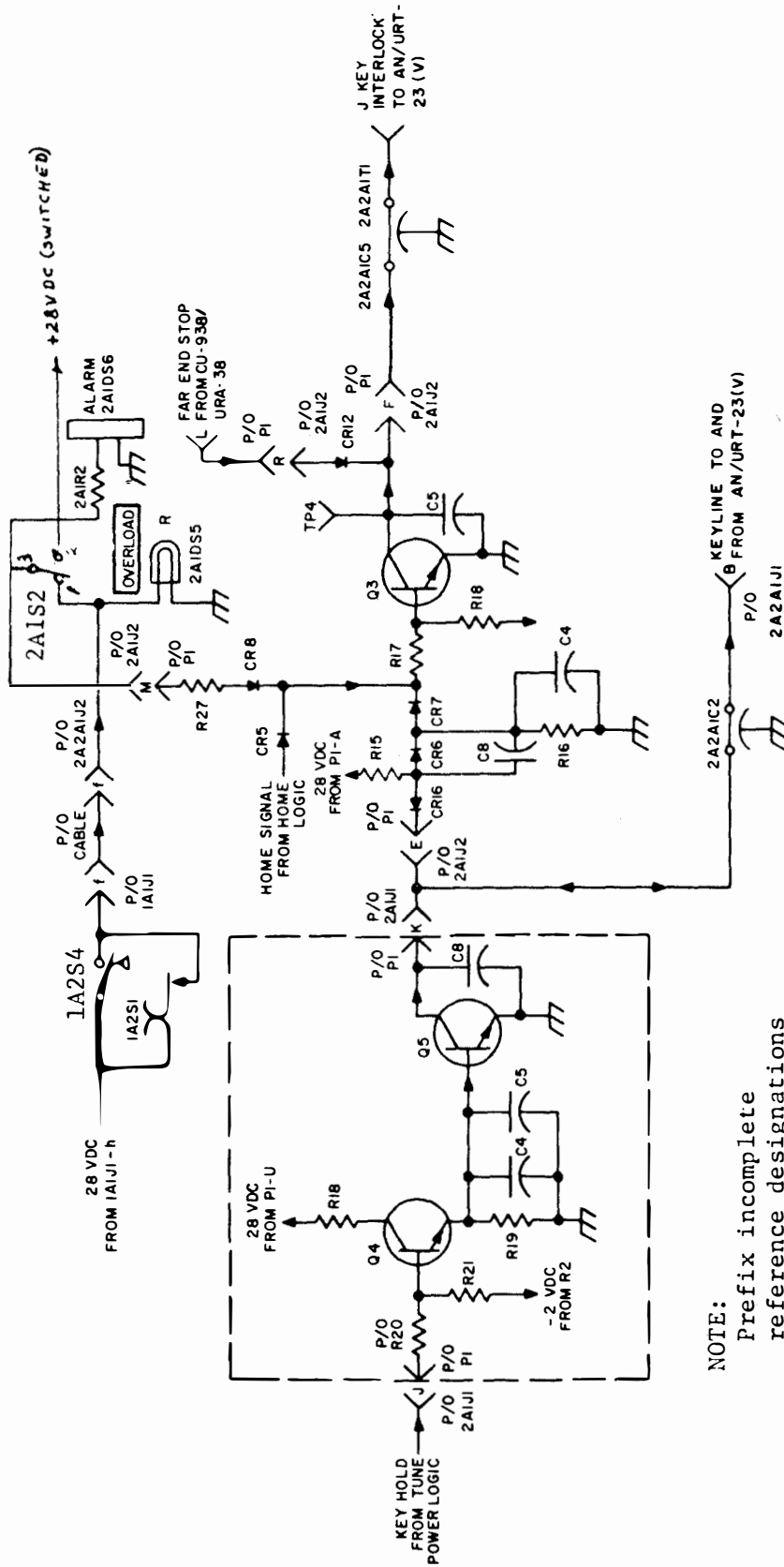

NOTE:  
Prefix incomplete  
reference designations  
with 2A1A4

Figure 4-14. Keying Logic, Simplified Schematic Diagram

to OVERLOAD indicator 2A1DS5 and alarm 2A1DS6 to provide visual and audible indication that an overload exists. A switch (2A1S2) is provided to disconnect the alarm if desired.

4-88. READY LIGHT LOGIC CIRCUIT DESCRIPTION. The ready light logic (figure 4-15) consists of a driver (Q6), and various diode gate and switching circuits. The function of these circuits is to light READY indicator 2A1DS4 when the tuning cycle has been completed. These circuits are operational only in the automatic mode.

4-89. During the home portion of the tuning cycle, the base of transistor Q6 is held at ground through transistor Q1 in the home logic. At the completion of the home cycle, this line goes positive. However, the reset line holds the base of transistor Q6 at ground throughout the tuning cycle; initially through the end stop switch when the variable inductor is at home, and then through inverter Q4 in the tune logic (paragraph 4-82). These grounds inhibit the positive output from the home logic from turning on driver Q6. At the completion of the tuning cycle the inhibits are removed, allowing the positive output from the home logic to be developed across voltage divider R11-R12. This forward biases driver Q6, allowing READY indicator lamp 2A1DS4 to ground through transistor Q6.

4-90. If one of the elements traverses to the far end stop (end opposite home position), a ground is applied through end stop switch 1A2A1S1 or 1A2A3S1, pin L of connector 1A1J1, the interconnecting cable, pin L of connector 2A2A1J2, pin R of connectors 2A1J2 and P1, and diode CR3 to the base of driver Q6. This prevents the READY light from lighting, indicating that a malfunction has occurred.

4-91. LOGIC TEST DATA.

4-92. Pertinent references and applicable data for the logic circuits are:

- a. Antenna Coupler Control C-3698/URA-38, Schematic Diagram, Figure 5-16.
- b. Printed Circuit Board 2A1A3, Component and Test Point Locations, Figure 5-10.
- c. Printed Circuit Board 2A1A4, Component and Test Point Locations, Figure 5-11.
- d. Antenna Coupler Control C-3698/URA-38 Chassis, Component Locations, Figure 5-8.
- e. Antenna Coupler Group AN/URA-38, Logic and Power Supply, Servicing Block Diagram, Figure 4-19.
- f. Antenna Coupler CU-938/URA-38, Schematic Diagram, Figure 5-15.
- g. Transistor Voltage Measurements, Paragraph 5-39.
- h. Required Test Equipment:
  - (1) Multimeter AN/PSM-4.
  - (2) PC Board Extender, Paragraph 5-31.

4-93. STANDBY LIGHT. The lamp will be OFF when the transmitter is keyed and lighted in STANDBY, indicating proper function of Surveillance Disable Transistor 2A1A3Q1.



4-94 GENERAL: The Surveillance Disable circuit (Fig 4-16) consists of a single switching circuit. The function of this circuit is to disable the Servo amplifiers (Automatic and Silent tuning) when the transmitter is unkeyed, thus preventing accidental false tuning during a period of Standby or Receive. A strong signal from a nearby transmitter on a different operating frequency could induce voltages in the CU-938/URA-38 Antenna tuning network large enough to generate discriminator error signals which can cause the servos to go to some random position if the servo amplifiers were not thus interlocked with the Keyline.

NOTE: A strong signal can "capture" the servos during a pause in SSB modulation or while in a KEY UP condition of CW. This can be prevented by switching to MANUAL after AUTO tune-up.

4-95 CIRCUIT DESCRIPTION: When the system is Keyed for transmitting, a ground is applied through connector 2A1A3P1(k) to the cathode of diode 2A1A3CR4, dropping the voltage applied to zener diode 2A1A3VR3 below its threshold. Transistor 2A1A3Q1 then turns off, removing the grounding Disable from the servo amplifiers at pins 2A1A1(u) and 2A1A2(u). Also deenergizes fan control relay 1A2K1 by removing the ground. This relay controls the operating voltage of the cooling fan in the CU-938 through a set of normally closed contacts. Operation of the STANDBY lamp as in 4-93 checks the operation of Transistor 2A1A3Q1.

4-96. TEST DATA. Pertinent references and applicable data for the Surveillance circuit are:

- a. Antenna Coupler CU-938/URA-38 Schematic Diagram, Figure 5-15.
- b. Antenna Coupler CU-938/URA-38 Chassis Component Locations, Figure 5-4.
- c. Antenna Coupler Control C-3698/URA-38, Schematic Diagram, Figure 5-16.
- d. Printed Circuit Board 2A1A3, Component and Test Point Locations, Figure 5-10.
- e. Antenna Coupler Group AN/URA-38, Servo Loops and Matching Network, Servicing Block Diagram, Figure 4-20.
- f. Required Test Equipment:
  - (1) Multimeter AN/PSM-4
  - (2) PC Board Extender, Paragraph 5-31.
- g. Transistor Voltage Measurements, Paragraph 5-39.

#### 4-97. POWER SUPPLY.

4-98. GENERAL. The power supply (figure 4-17) consists of a transformer (T1), rectifiers (A3CR1 and A3CR5 through A3CR8), and various other components. This circuit produces all DC operating voltages required by the AN/URA-38.

4-99. CIRCUIT DESCRIPTION. The 115 VAC, 48 to 63 or 350 to 450 CPS, single phase primary power is applied through pins M and L of connector 2A2A1J1, feedthru capacitors 2A2A1C6 and 2A2A1C4, interlock switches S11 and S8, POWER switch S7, and fuses F1 and F2 to the primary of transformer T1. Interlock switches S11 and S8 interrupt the primary power when the C-3698/URA-38 chassis is extended from its case. Transformer T1 secondary 3-4 steps down the 115 VAC and applies the resulting voltage through pins B and C of

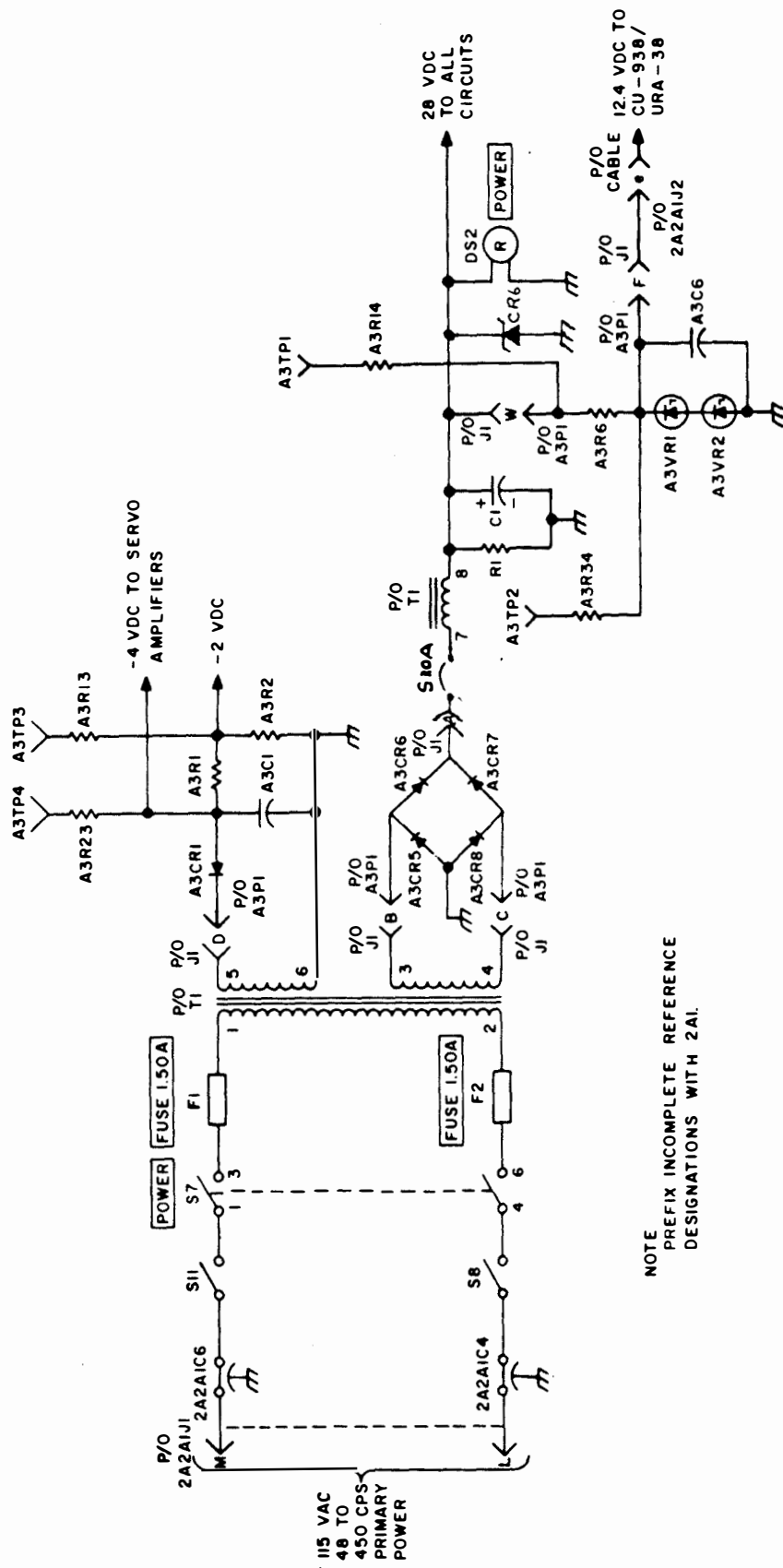

Figure 4-17. Power Supply, Simplified Schematic Diagram



connectors J1 and A3P1 to full-wave bridge rectifier A3CR5 through A3CR8. The DC output from the bridge rectifier is filtered by the inductor portion of T1 (terminals 7-8) and capacitor C1 to provide 28 VDC operating voltage for the servo motors, transistor circuits, relays, and indicator lamps. POWER indicator DS2 lights when the power supply has energized. The 28 VDC also supplies the 12.4 VDC regulator which consists of Zener diodes A3VR1 and A3VR2 and resistor A3R6. The 12.4 VDC is applied to the position potentiometers in the CU-938/URA-38 to enable the position of the tuning elements to be determined with the ELEMENT POSITION meter.

4-100. The 115 VAC primary power is also stepped down by transformer T1 secondary 5-6 and applied through pin D of connectors J1 and A3P1 to half-wave rectifier A3CR1. The output from this rectifier is filtered by capacitor A3C1 to provide -4 VDC to the servo amplifiers (paragraph 4-53). The -4 VDC is also divided to -2 VDC by resistors A3R1 and A3R2. This voltage is used in the transistor stages in the logic circuits as a base return to ensure reliable cutoff.

4-101. TEST DATA. Pertinent references and applicable data for the power supply are:

- a. Antenna Coupler Control C-3698/URA-38, Schematic Diagram, Figure 5-16.
- b. Antenna Coupler Control C-3698/URA-38 Chassis Component Locations, Figure 5-8.
- c. Printed Circuit Board 2A1A3, Component and Test Point Locations, Figure 5-10.
- d. Antenna Coupler Group AN/URA-38, Logic and Power Supply, Servicing Block Diagram, Figure 4-19.
- e. Required Test Equipment:
  - (1) Multimeter AN/PSM-4
  - (2) PC Board Extender, Paragraph 5-31.

4-102. HEAT EXCHANGER.

4-103. The fan used in the heat exchanger (figure 4-18) can be operated from a 48 to 63 or 350 to 450, 115 volt, single phase primary power source. The power applied to the primary of transformer 2A1T1 is applied to either the 60 CPS or 400 CPS input of fan 1A2A1B1 by connecting terminal 2 of terminal board 2A1TB1 to either terminal 1 or terminal 3 at the time of installation according to the frequency of the primary power source.

4-104. The fan and case form a heat exchanger which is used to dissipate the heat produced by inductor 1A2L1 (heat producing element). The fan circulates the nitrogen atmosphere over and through the inductor, and then through the air duct between the bottom of the case and the chassis. The heat is transferred to the nitrogen as it passes over the inductor, and then from the nitrogen to the case as it passes through the air duct. The heat is expelled from the case to the outside air and mounting structures by a combination of conduction, convection, and radiation.

4-105. SYSTEM TROUBLESHOOTING.

4-106. Table 4-1 is not intended to be a complete troubleshooting chart. Instead, it provides a listing of symptoms and probable faults most likely to be encountered when troubleshooting the equipment. This quick reference information may isolate a problem area without the requirement of a detailed analysis.

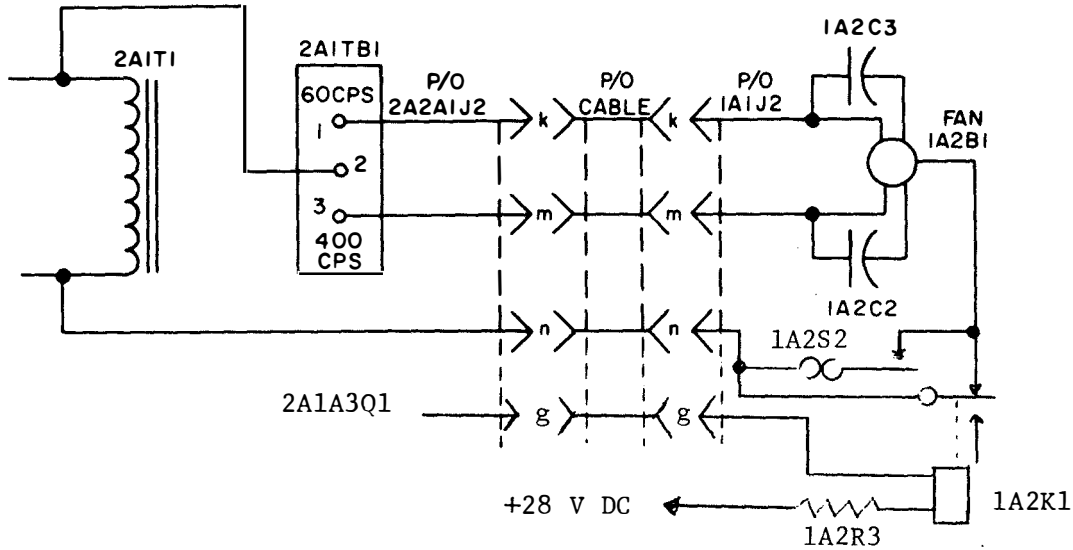

A. FAN, SIMPLIFIED SCHEMATIC DIAGRAM

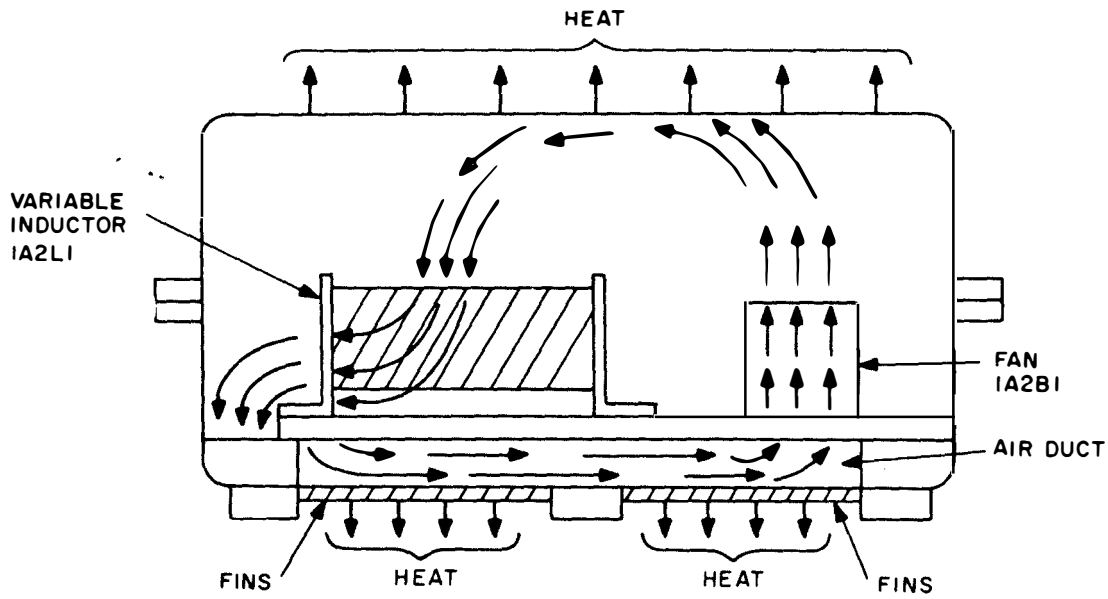

B. AIR FLOW DIAGRAM

Figure 4-18. Heat Exchanger

TABLE 4-1. TROUBLESHOOTING

SYMPTOM	PROBABLE FAULT
RF power is removed as soon as TUNE KEY is released during automatic operation.	<ol style="list-style-type: none"> <li>1. Defective motor-on logic.</li> <li>2. Defective tune logic.</li> <li>3. Defective keying logic.</li> </ol>
System can not be energized.	<ol style="list-style-type: none"> <li>1. AM-3924(P)/URT POWER is not set at ON.</li> <li>2. Open interlock switch 2A1S8 or 2A1S11.</li> <li>3. Open fuse 2A1F1 or 2A1F2.</li> </ol>
A tune condition can not be achieved (VSWR less than 1.5:1).	<ol style="list-style-type: none"> <li>1. Defective or unbalanced servo amplifier.</li> <li>2. Defective forcing.</li> <li>3. Defective or mistuned discriminator assembly.</li> <li>4. No tune sensitivity drive.</li> <li>5. Adequate time power not maintained throughout time cycle.</li> </ol>
Erratic logic signals during silent or automatic operation.	Defective -2 VDC power supply.
Can not tune at low frequencies (2 to 6 MC).	Defective forcing.
Tuning elements can not be repositioned.	Defective brake logic.
Fuse 2A1F1 or 2A1F2 opens.	<ol style="list-style-type: none"> <li>1. Shorted power transistor (2A1Q1 through 2A1Q8).</li> <li>2. Defective home logic.</li> <li>3. Defective 28 VDC supply.</li> </ol>
No RF power applied during automatic operation.	<ol style="list-style-type: none"> <li>1. Defective home logic.</li> <li>2. Defective keying logic.</li> </ol>
Elements do not go to home when frequency is changed.	<ol style="list-style-type: none"> <li>1. No ground pulse from transmitter.</li> <li>2. Defective home logic.</li> </ol>
After homing, TUNING lamp does not come on when system is keyed.	<ol style="list-style-type: none"> <li>1. Inadequate RF power for tuning.</li> <li>2. Faulty or mistuned discriminator(s).</li> <li>3. Faulty or misbalanced servo amplifiers.</li> <li>4. Faulty motor drive transistors.</li> </ol>
System does not lock in the system key to maintain RF signal for tuning; however will tune if system is held keyed manually.	<ol style="list-style-type: none"> <li>1. Faulty brake logic or brakes.</li> <li>2. Motor drive system jammed.</li> </ol>
Ready light does not come on at completion of tuning.	<ol style="list-style-type: none"> <li>1. Tuning element run up against far end stop switch.</li> </ol>

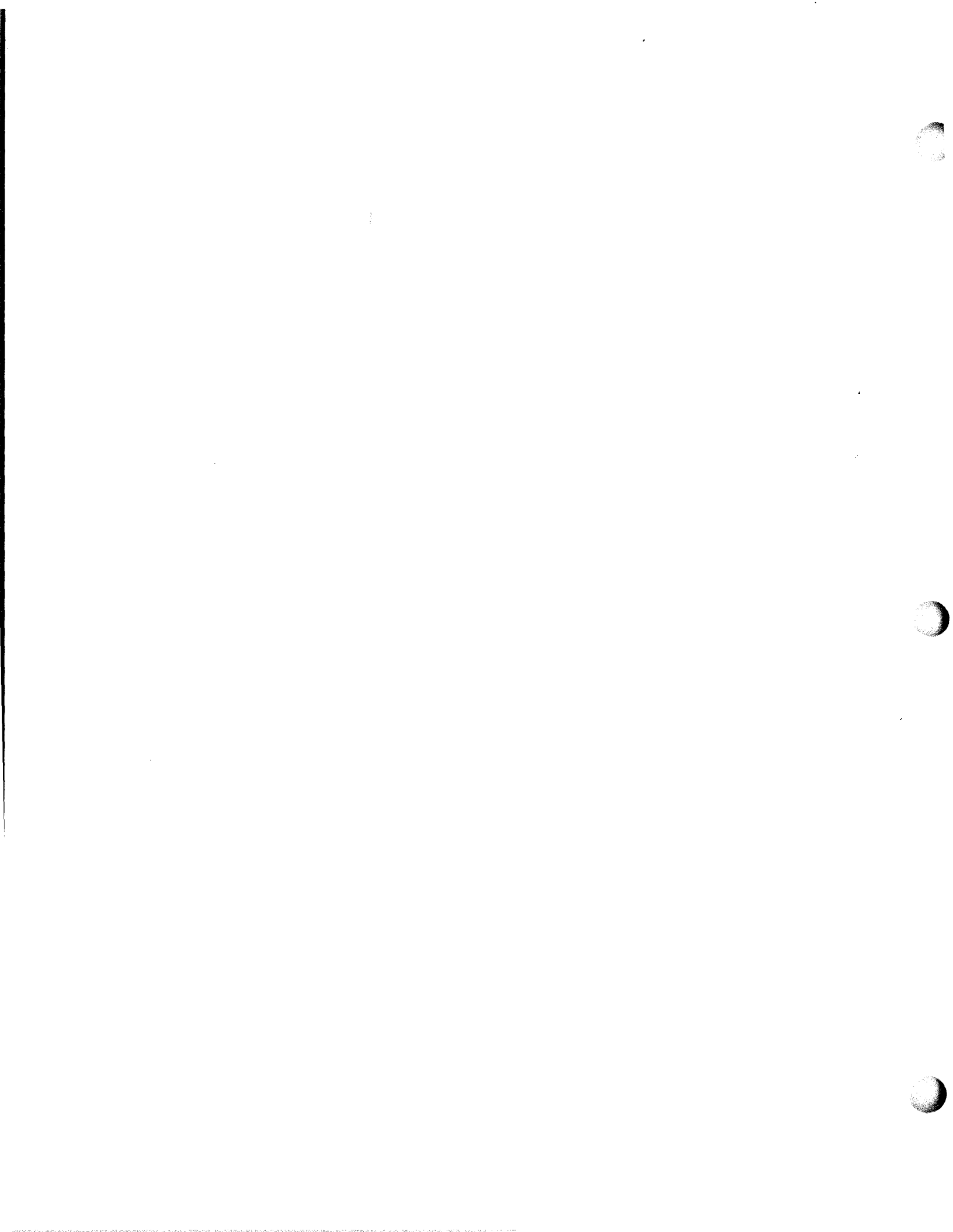

- Notes
- Letters outside transistor and diode blocks indicate element.
  - Heavy lines indicate main signal paths.
  - Light lines indicate auxiliary or secondary signal paths.
  - All measurements taken with AN/PSM-4 and should be within 20% of the indicated value, unless otherwise specified.
  - All measurements made with switch 2A1S1 set at AUTO.

TEST POINT INFORMATION

TEST POINT	CONDITION	DC VOLTAGE
1 (A2TP4)	"Home" signal from discriminator "Tune" signal from discriminator Normal (No. RF, or coupler tuned)	+ .1 to + .5 V - .1 to - .6 V 0 V
2 (A2TP3)		0 V
3 (A2TP6)	NO INPUT TUNE INPUT HOME INPUT	+31.0v +0.014v +28.0v
4 (A2TP1)	NO INPUT TUNE INPUT HOME INPUT	+31.0v +28.0v +28.0v
A (A2TP5)	Tuning Otherwise	+2.5 V 0 V
B (A2TP2)	Homing Otherwise	+2.5 V 0 V

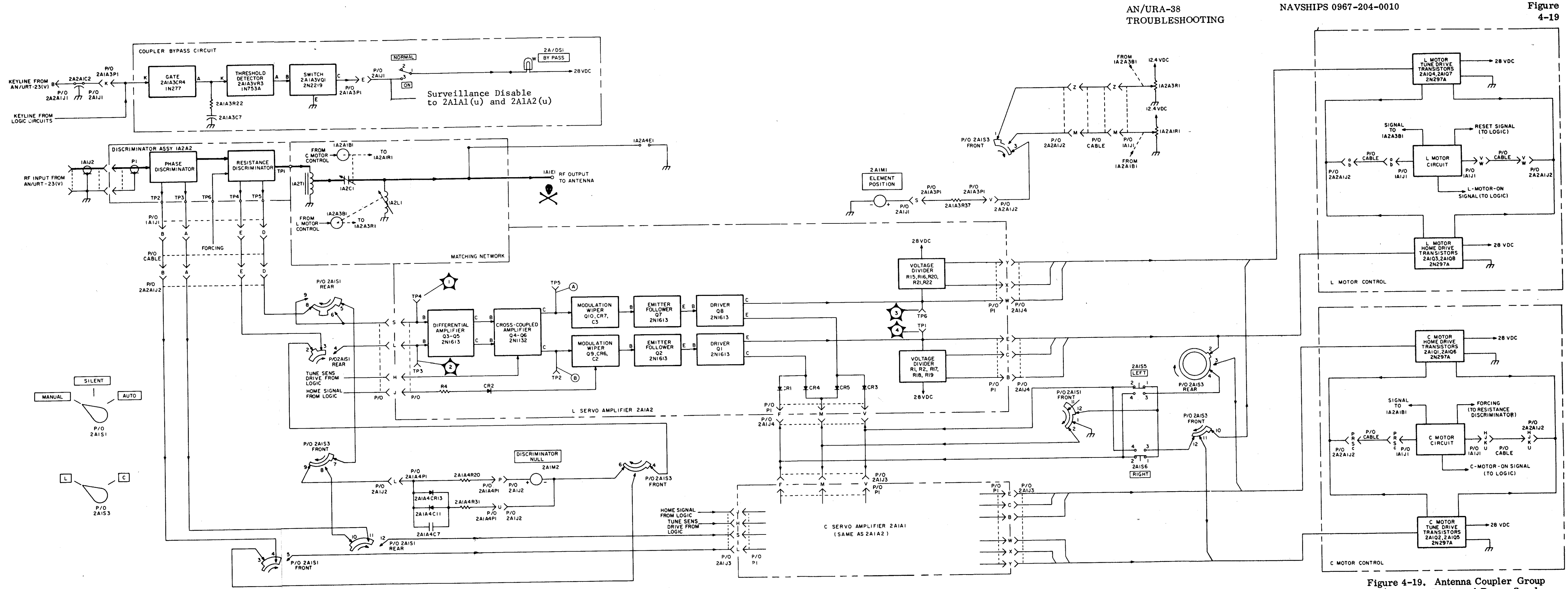

Figure 4-19. Antenna Coupler Group AN/URA-38, Logic and Power Supply, Servicing Block Diagram

ORIGINAL

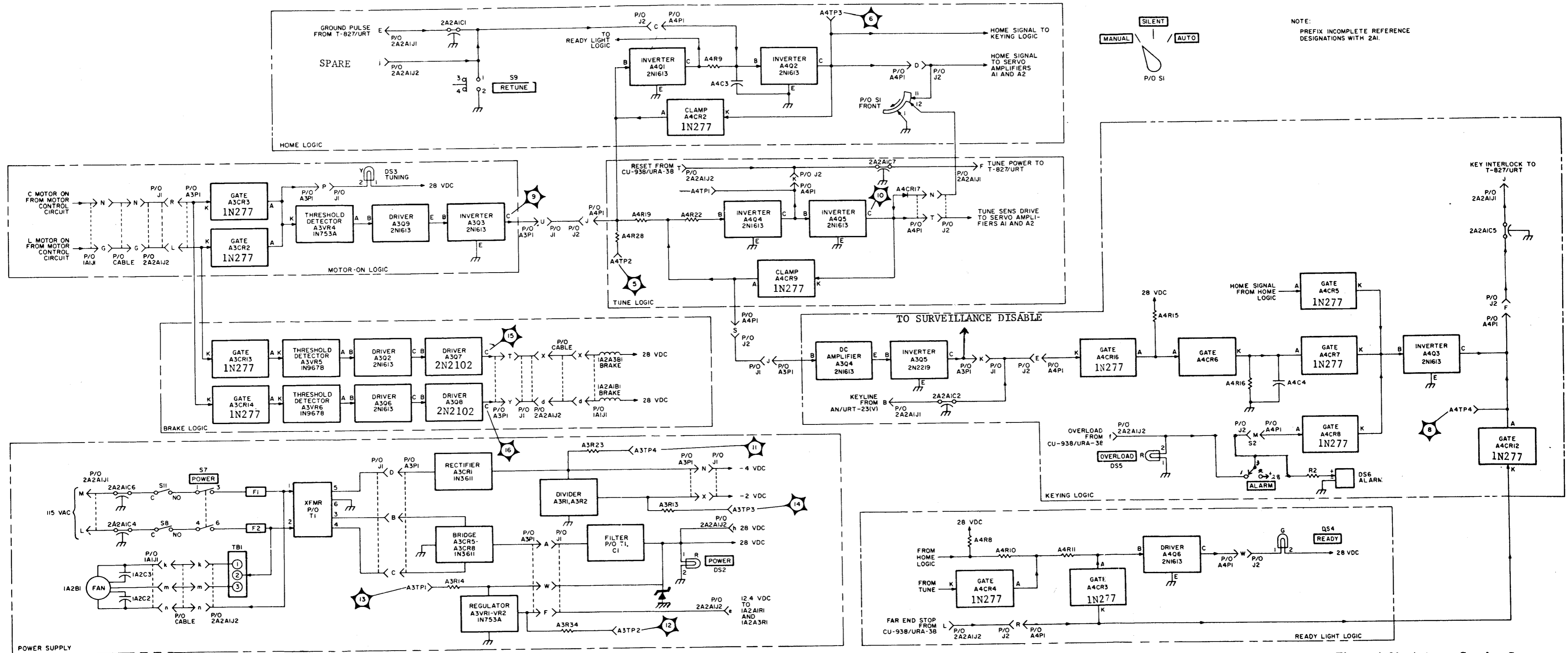

Figure 4-20. Antenna Coupler Group AN/URA-38 Servo Loops and Matching Network, Servicing Block Diagram

ORIGINAL

SECTION 5  
MAINTENANCE

5-1. FAILURE, AND PERFORMANCE AND OPERATION REPORTS.

5-2. The Naval Ship Systems Command no longer requires the submission of failure reports for all equipments. Failure Reports and Performance and Operation Reports are to be accomplished for designated equipments (refer to Electronics Installation and Maintenance Book NAVSHIPS 900,000) only to the extent required by existing directives. All failures shall be reported for those equipments requiring the use of Failure Reports.

5-3. TUNING AND ADJUSTMENT.

WARNING

The CU-938/URA-38 is extremely hazardous when operated or removed from the case. The following precautions should be taken when the CU-938/URA-38 is removed from its case.

- a. Never touch the unit before checking that the transmitter is unkeyed.
- b. Never let bystanders approach within arms length of the unit while it is being operated.
- c. Never leave the unit unattended while the transmitter is keyed.
- d. Always clear the area within arms length of the unit before keying the transmitter.
- e. Before attempting to remove the unit from its mounting, disconnect the interconnecting cables. ALWAYS REMOVE THE RF INPUT CABLE BEFORE DISCONNECTING THE ANTENNA CABLE.

5-4. DISCRIMINATOR.

5-5. GENERAL. The discriminator adjustment procedures are critical. Maladjustment could damage the equipment, depending on the degree of mismatch between the transmitter and the antenna. Therefore, the procedures should be followed only when the assembly has been repaired or if specific reference has been made to these procedures from Section 4 of this manual.

5-6. TEST EQUIPMENT AND SPECIAL TOOLS. The following test equipment and special tools are required to adjust the discriminator assembly.

- a. Fiber Screwdriver adjustment Tool (2 inches long).
- b. Test Cables (paragraph 5-33).
- c. Torque Wrench (60-100 in-lbs).

- d. Electrical Dummy Load DA-242/U.

5-7 TEST SETUP: Connect the equipment as follows:

- a. Depress plunger in the CU-938/URA-38 charging valve 1A1MP4 and depressurize the case until the gauge indicates zero.
- b. Remove the 28 cover bolts, retain.
- c. Remove and set aside the cover and gasket.
- d. Extreme caution should be exercised to prevent the sealing flanges of the case bottom and top from being nicked, scratched or marked in any way.
- e. Unsolder the lead between the Discriminator assembly 1A2A2 terminal TP1 and the toroid transformer 1A2T1(1).
- f. Interconnect the CU-938/URA-38 and the C-3698/URA-38 using the 10 foot control cable fabricated in paragraph 5-33. Apply power to the associated transmitter AN/URT-23.
- g. Set C-3698/URA-38 power switch to ON.
- h. Set Mode selector switch to MANUAL and the L-C switch to C.
- i. Depress the right pushbutton to ensure that the variable capacitor is not at the Home end stop.
- j. Set power switch to OFF.
- k. Using the Discriminator alignment cable fabricated previously (para. 5-33) solder the short center conductor lead to 1A2A2-TP1 and the braid to the nearest ground point. Connect the other end of the cable to the DA-242/U.
- l. Connect the RF output cable fabricated in paragraph 5-33 between the transmitter and connector 1A1J2 on the CU-938/URA-38.

5-8 CONTROL SETTINGS: Energize the AN/URT-23 transmitter in the AM mode of operation for 21.00 MHz. Set the Mode selector switch on the C-3698/URA-38 to MANUAL.

5-9 DISCRIMINATOR ASSEMBLY ADJUSTMENT:

- a. Check and adjust the Discriminator null meter 2A1M2 pointer for a center line Zero. See Diagram A. Mechanically adjust the pointer if necessary.
- b. Key the transmitter and adjust the level set for 150 watts output.
- c. With the L-C Switch set at "L", adjust the Discriminator Assembly Capacitor 1A2A2(C6) so that the meter will swing to both sides of center line. This verifies operation of both diodes. Make the final setting at the center null line. Diagram A.
- d. Unkey the transmitter and set the transmitter frequency to 29.99 MHz.



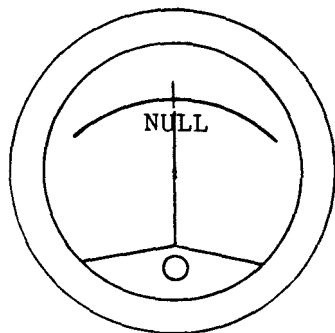

Diagram A

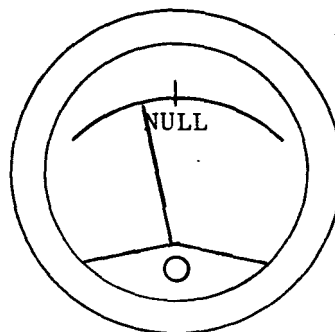

Diagram B

- e. Key the transmitter and adjust to 150 watts output.
- f. With the L-C Switch set at "C", adjust the Discriminator Assembly Potentiometer 1A2A2(R6) to both sides of the letter "N" in null on the face of the meter. The leading edge of the "N" is the negative 100 millivolt offset required. After assuring that the signal will swing to each side of the "N" final set the pointer at the leading edge of the "N" as in diagram B.
- g. CHECK steps (b) and (c) at 21.000 MHz. CHECK steps (e) and (f) at 29.999 Mhz. Repeat the adjustments of (a), (b), (f) and (g) until there is no further interaction.
- h. UnKey transmitter. Unsolder the test cable from the Discriminator and resolder the lead from TP1 and the toroid transformer terminal 1A2T1(1).
- i. If further maintenance is to be accomplished proceed as required; if not, proceed to step (j).
- j. Clean the case top and bottom mating flanges with a clean disposable wiper and apply a thin coat of silicone grease DC-4 or DC-33 to both surfaces.
- k. Apply a light coat of the silicone grease to the gasket and place it on case.
- l. Fasten cover screws with a torque of 70 in-lbs.
- m. Pressurize case using the procedures in paragraph 2-30.

#### 5-10. SERVO AMPLIFIERS.

5-11. GENERAL. The servo amplifiers should be adjusted whenever one of the assemblies has been repaired or if reference has been made to these procedures from section 4.

5-12. TEST EQUIPMENT. The following test equipment is required to perform the servo amplifier adjustment.

- a. Antenna Alignment Test Set TS-3228/URA-38

5-13. SPECIAL FIXTURE. Test Set TS-3228/URA-38 is shown in figure 5-1.

5-14. CONTROL SETTINGS. Set the Mode Selector switch at AUTO prior to starting the procedures.

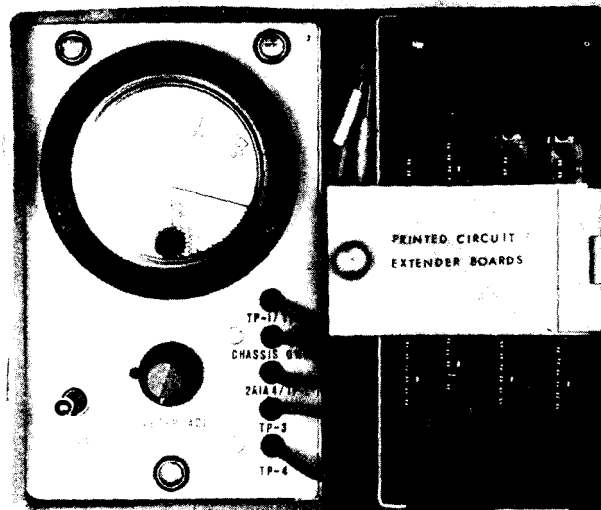

Figure 5-1 Servo Alignment Test Set TS-3228/URA-38

5-15. TEST SETUP. Connect the equipment as follows:

- a. Set the mode selector switch to MANUAL and drive the variable inductor (L) and variable capacitor (C) out of the Home end stops.
- b. Disconnect the control cable J2 from the C-3698/URA-38.
- c. Set the mode selector switch to AUTO.
- d. Loosen the front panel captive screws (4) on the C-3698/URA-38 and swing the chassis out from its case.
- e. Defeat the electrical interlock switches located on the rear of the chassis by pulling the plungers straight out.
- f. Connect the leads of the test fixture to the points indicated in Figure 5-1 on the servo board under test. Simulate a Keyed condition by grounding the Keyline feed thru bypass capacitor 2A2A1C2.

5-16. INSTRUCTIONS. To adjust the servo amplifier, proceed as follows:

- a. Turn the power switch of the C-3698 to ON.
- b. Remove the tip plug from 2A1A4 TP1 and assure that the ready light on the front panel illuminates. Replace the tip plug in 2A1A4 TP1.
- c. Set test fixture switch in the TP1 position.
- d. Assure that the test fixture is connected to TP1 on the servo board under alignment and then adjust the test fixture potentiometer for a minimum DC voltage reading on the test fixture meter.

## 5-16(cont)

e. Adjust the test fixture potentiometer for a reading 1 to 2 volts above the initial minimum setting. No further adjustment of the potentiometer should be necessary.

f. Remove the tip plug from TP1 on the servo board.

g. Change the test fixture switch to TP6.

h. Connect the tip plug to TP6 and adjust the servo balance potentiometer (2A1A1R8 or 2A1A2R8 as appropriate) to a reading approximately half way between the Step (e) reading and the initial reading of this step after inserting the tip plug in TP6.

i. Alternately change the tip plug and the test fixture switch between TP1 and TP6 until they read exactly the same. Repeat for the other servo board.

j. Disconnect all test equipment and return the C-3698/URA-38 to its normal operational condition.

5-17. REPAIR.

## 5-18. ANTENNA COUPLER CONTROL C-3698/URA-38.

5-19. GENERAL. The method of removal and replacement of parts in the C-3698/URA-38 is obvious. However, the information provided in paragraph 5-20 should be followed when replacing parts on the printed circuit board assemblies.

5-20. GENERAL PCB PARTS REPLACEMENT TECHNIQUES. When repairing printed circuit boards, the procedures below should be carefully followed to avoid damage.

a. Use a pencil-type soldering iron with 25 watt maximum capacity. Use an isolating transformer with an ac-operated iron. Do not use a soldering gun; damaging voltages can be induced into the components.

b. When soldering transistors or diodes, solder quickly; where wiring permits, use a heat sink (such as long nose pliers) between the soldered joint and the part being replaced.

c. Excessive heat can separate the copper strip from the board. Cement such strips in place with a quick drying acetate base cement having good electrical insulating properties.

d. Use high quality rosin core solder when repairing printed circuit boards. NEVER USE PASTE FLUX. After soldering, clean off any excessive flux and coat the repair area with a high quality electrical varnish or lacquer.

e. Repair a break in the copper of a printed circuit board by soldering a buss wire across the break.

f. When removing parts from a printed circuit board, apply heat sparingly to the lead of the part to be replaced. Remove part from the printed circuit board as the iron heats the lead. Use an awl to carefully clean the inside of the holes left by the old part.

g. When the part is replaced, tin the leads on the new part. Bend the clean tinned leads on the new part and carefully insert them through the holes in the printed circuit

board. Bend the leads close to the foil and cut so that approximately one-sixteenth of an inch of lead length is left. Hold part against the board and quickly solder the leads.

5-21. ANTENNA COUPLER CU-938/URA-38.

5-22. GENERAL. Removal and replacement of many of the parts in the CU-938/URA-38 require procedures which are not obvious. Paragraphs 5-24 through 5-30 provide all the necessary information for replacement of those parts. All screws removed during the repair procedures must be torqued when replaced. Table 5-1 provides a listing of the torque required for the different types of screws used in the CU-938/URA-38. When repairing the discriminator assembly, the general information in paragraph 5-20 should be followed. The procedures in paragraphs 5-24 through 5-30 assume that the following procedure has been performed.

CAUTION

Extreme care should be exercised to prevent the sealing flanges on the case or cover from being nicked, scratched or marked in any way. This type of damage prevents the unit from being properly sealed. Therefore, always protect the flanges from damage while the equipment is being serviced. Use a new gasket each time the CU-938/URA-38 is reassembled.

- a. Depressurize CU-938/URA-38 by depressing plunger in charging valve.
- b. Remove 28 screws around case. Remove cover and discard gasket.
- c. Connect C-3698/URA-38 and DA-242/U to the CU-938/URA-38 using the cables fabricated in paragraph 5-33. Connect primary power to C-3698/URA-38 connector J1.
- d. Cover exposed flanges on case with cloth or pressure sensitive tape.

Note

Save all hardware removed while performing the disassembly procedures. Reassembly procedures require the use of this hardware. Note the order in which hardware is removed. Flat washers are always placed next to plastic with lockwashers between the flat washers and nut or screw head.

TABLE 5-1. TORQUE REQUIREMENTS FOR SCREWS

SCREW SIZE	TORQUE REQUIRED
4-40	6 ± 5% in-lbs
6-32	10 ± 5% in-lbs
8-32	21 ± 5% in-lbs
10-32	33 ± 5% in-lbs

5-23. REMOVAL OF CHASSIS FROM CASE. For most parts replacement procedures, mounting hardware and adjustments will be more excessable if the CU-938/URA-38 chassis is removed from the case. To remove the chassis, proceed as follows:

- a. Remove cover and gasket from case according to steps a and b of paragraph 5-22.
- b. Remove and set aside the sixteen screws (fourteen around edge and two in center) which secure chassis to case.
- c. Unsolder and tape the two leads to pressure switch 1A1S1.
- d. Remove jam nut from each connector and carefully push connectors inside case. (The larger connector should not be pushed through until chassis is slid forward slightly to provide clearance.)
- e. Remove the wire from the stud on inside end of antenna terminal. Replace loose hardware on terminal for storage.
- f. Carefully lift chassis out from case and place it on a convenient working surface.

WARNING

Be extremely cautious when operating the CU-938/URA-38 removed from the case. Lethal RF voltages will be present when system is keyed and connected to a transmitter.

- g. Connect C-3698/URA-38 and DA-242/U to CU-938/URA-38 with the cables fabricated in paragraph 5-33. Connect primary power to C-3698/URA-38.

5-24. ELEMENT POSITION POTENTIOMETER REPLACEMENT. The following procedure details the steps necessary to replace element position potentiometer R1 on either capacitor gear drive assembly 1A2A1 or inductor gear drive assembly 1A2A3.

- a. Remove chassis from case as explained in paragraph 5-23.
- b. Set mode Selector switch at AUTO, then POWER switch at ON.
- c. Allow elements time to home, then set POWER switch at OFF.
- d. Tag and unsolder wires connected to each terminal of potentiometer (figure 5-4).

Note

Before proceeding, note orientation of bracket, potentiometer indexing tab, and potentiometer to prevent installation rotated 180 degrees from original position. The potentiometer shaft is slotted. It is not necessary to remove pin from end stop switch lever arm.

- e. Remove and set aside the two screws securing potentiometer mounting bracket. Pull bracket straight away from gear drive housing to disengage potentiometer shaft.
- f. Remove potentiometer from bracket.

CAUTION

Damage to gear drive assembly will result if potentiometer shaft is incorrectly oriented.

- g. Mount and secure new (replacement) potentiometer on bracket. Check that indexing tab is in correct hole in bracket.
- h. Rotate potentiometer shaft to its maximum position as viewed from shaft end; fully clockwise for potentiometer on inductor gear drive assembly, or fully counterclockwise for potentiometer on capacitor gear drive assembly.
- i. Position potentiometer mounting bracket on gear drive housing, rotating potentiometer shaft slightly as necessary to align slot in shaft with pin in end step switch lever arm.
- j. Secure potentiometer mounting bracket with screws removed in step e.
- k. Resolder wires removed in step d.
- l. Remove and set aside the four machine screws securing servo motor mounting bracket.
- m. Slide servo motor away from gear drive assembly to disengage gears.
- n. Rotate gear drive assembly by hand from one end of its range to the other to ensure smooth operation.
- o. Replace servo motor and mounting bracket using screws removed in step l.
- p. If no further maintenance is required, replace chassis in case by performing steps in paragraph 5-23, in reverse order.
- q. Replace cover on case by performing steps m through p of paragraph 5-9.

5-25. SERVO MOTOR REPLACEMENT. To replace the servo motor on either of the gear drive assemblies, proceed as follows.

Note

The replacement procedure can be more easily accomplished if the chassis is removed from the case (paragraph 5-23).

- a. If L servo motor is to be replaced, remove and set aside the four machine screws securing blower motor to chassis. This allows access to unsolder servo motor leads. (Blower motor leads need not be unsoldered.)
- b. Tag and unsolder servo motor leads (figure 5-4).
- c. Remove and set aside servo motor lead clamp.
- d. Remove and set aside the four machine screws securing servo motor clamp.
- e. Remove servo motor from gear drive assembly.

- f. Remove and set aside the two machine screws securing top mounting plate to servo motor; lift off top mounting plate.
- g. Position top mounting plate on new (replacement) servo motor and secure with two machine screws removed in step f.
- h. Position new servo motor on gear drive assembly with gears properly meshed and with motor leads facing as shown in figure 5-6.
- i. Replace servo motor clamp and secure with four machine screws removed in step d.
- j. Replace clamp removed in step c.
- k. Solder servo motor leads to terminals, using tags on defective motor as a guide.
- l. If blower motor was moved, reposition and secure using four machine screws removed in step a.
- m. If no further servicing is required, replace chassis (if removed) in case by performing steps of paragraph 5-23 in reverse order.
- n. Replace cover on case by performing steps m through p of paragraph 5-9.

5-26. GEAR DRIVE ASSEMBLY COMPONENT REPLACEMENT. The following procedure details the steps necessary to replace the mechanical components of capacitor gear drive assembly 1A2A1 or inductor gear drive assembly 1A2A3. Perform only those procedural steps required to replace the damaged part. When required to drill holes for pinning parts in new components, use a 0.0625 drill. Replace damaged pins with spring pin NO. MS51987-71. Four assembly fixtures will be required for mechanical alignment during reassembly. Figure 5-2 provides all information required to fabricate these items. Refer to figures 5-4 and 5-6 for locations of parts while performing the procedure.

- a. Remove chassis from case according to paragraph 5-23.
- b. Set Mode Selector switch at AUTO, then POWER switch at ON.
- c. Allow elements time to home, then set POWER switch at OFF.

Note

If mechanical damage prevents the elements from homing, manually set elements to home during reassembly.

- d. Loosen the two machine screws which secure coupling to primary shaft of gear drive assembly.
- e. Remove and set aside the two machine screws securing diode board to capacitor gear drive assembly or terminal board to inductor gear drive assembly. (If inductor gear drive assembly is being repaired, fan will have to be set aside to gain access. Remove the four machine screws securing fan to chassis; leads need not be unsoldered.)
- f. Remove and set aside three machine screws securing gear drive assembly to chassis.

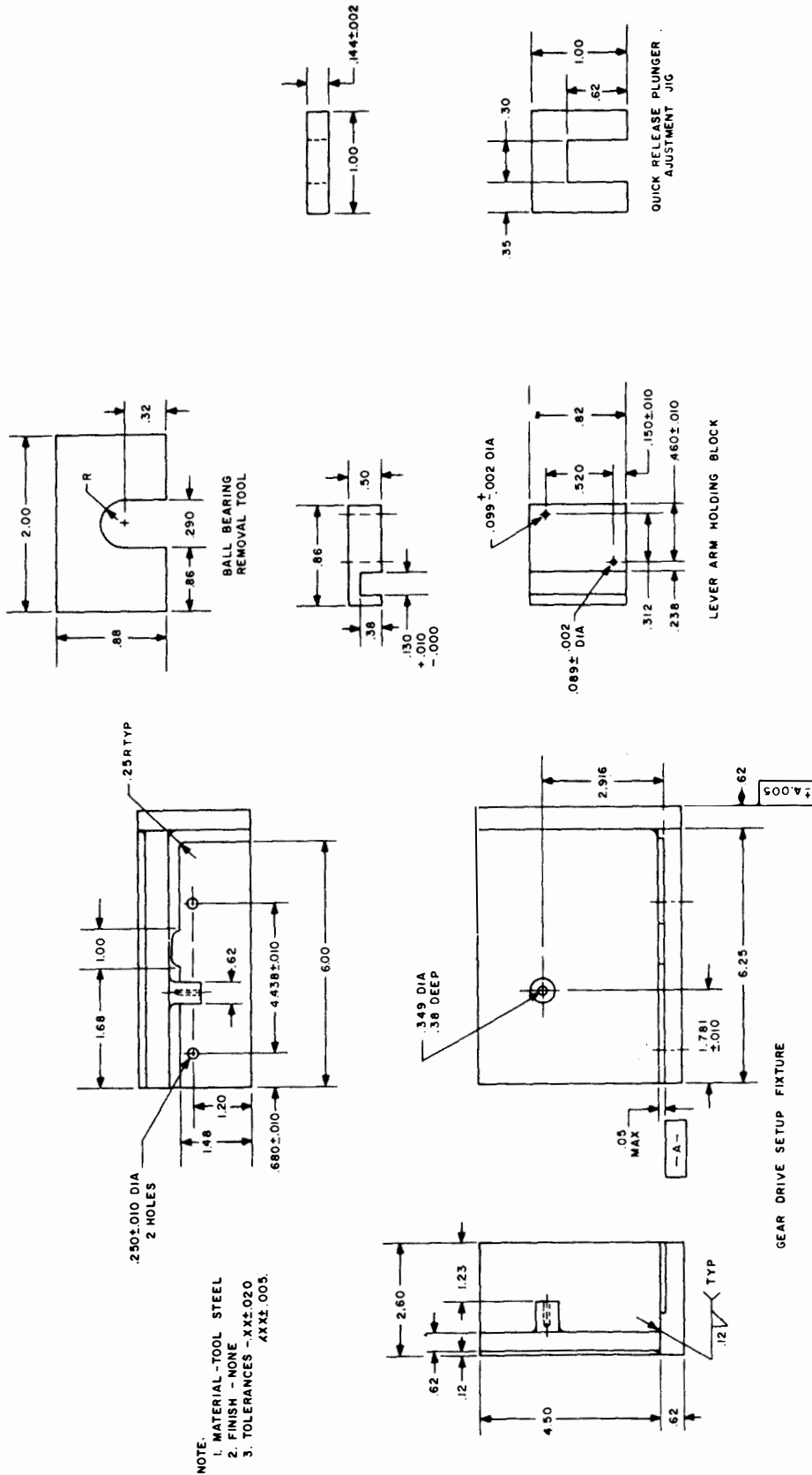

Figure 5-2. Gear Drive Assembly Fixtures and Jigs, Fabrication Diagram



g. Carefully slide gear drive assembly back to disengage coupling. (For inductor gear drive assembly, remove and set aside plastic insert in tripper arm coupling.)

h. Remove and set aside the two screws securing potentiometer bracket. Without disturbing potentiometer setting, disengage shaft and swing potentiometer bracket to one side.

#### CAUTION

Do not disturb the position of the end stop switches at this point in the procedure.

- i. Tag and unsolder leads to end stop switches.
- j. Tag and unsolder leads to servo motor.
- k. Lift gear drive assembly out from chassis.
- l. Remove and set aside four screws securing servo motor clamp; remove servo motor clamp.
- m. Slide servo motor out from gear drive housing.

#### Note

Perform steps n, o, and p only when repairing the inductor gear drive assembly.

- n. Loosen socket set screw on motor end of tripper arm.
- o. Remove 4 screws from microswitch assembly and set aside screws and microswitch assembly.
- p. Drive out pin which secures end stop switch lever to secondary shaft, and remove end stop switch lever.
- q. Remove and set aside snap ring on secondary shaft just underneath end stop switch lever, and slide secondary shaft out from gear drive housing. If defective, discard secondary shaft assembly.
- r. Steps s, t, and u should only be performed when primary shaft assembly required replacement.
- s. With a pencil, mark position of two bearing caps securing primary shaft assembly to gear drive housing, then remove two bearing caps.
- t. Remove and discard defective primary shaft assembly.

CAUTION

Prior to performing step u, a careful shim adjustment must be made. Laminated shims at each bearing on the primary shaft assembly must be adjusted to ensure less than one-degree total backlash at primary output shaft (including motor shaft end play), and 0.003 inch clearance between bearing faces and housing face. (Motor must be temporarily secured to gear drive housing to check backlash.) Use the ball bearing removal tool illustrated in figure 5-2 to remove bearings for shim adjustment. Shims must be adjusted by removing 0.002 inch thick laminations. One degree of total backlash equals 0.017 inch at a one inch radius measured at primary output shaft. An increase of one 0.002 inch shim lamination at output end bearing will decrease backlash of primary shaft 0.004 inch (14 minutes) at a one inch radius.

u. Position new (replacement) primary shaft assembly (with correct shim adjustment) to gear drive housing and secure with two bearing caps. (Bearing cap must be re-assembled to original location as marked in steps s.) *Note: See EIB 819.*

v. Slide secondary shaft assembly (new or original) into gear drive housing. Adjust shaft endplay to within 0.002 to 0.005 inch with supplied laminated shim, and secure with snap ring removed in step r. (One lamination equals 0.002 inch.)

w. Rotate primary shaft assembly to ensure smooth operation without binding. If binding occurs, remove secondary shaft and peel off one shim lamination (0.002 inch) and then reinstall shaft assembly.

x. Set gear drive housing on gear drive setup fixture (figure 5-2). Orient secondary shaft so that tripper pin on secondary shaft gear is centered in indexing hole on face of setup fixture. Bolt gear drive assembly to test fixture.

y. Remove two end stop switches from gear drive housing.

z. Remove two quick release plungers from end stop switch lever removed in step q, and then slide end stop switch lever on to end of secondary shaft assembly.

Note

The lever arm holding block (figure 5-2) fits over the top of the end stop switch lever, and is temporarily secured in place of the home end stop switch to orient the end stop switch lever for pinning.

aa. Set lever arm holding block over end stop switch lever and secure to gear drive housing in position of home end stop switch using two machine screws normally used to secure home end stop switch to gear drive housing.

ab. Drill (if required) and pin end stop switch lever to secondary shaft using an 0.0625 drill and an MS51987-71 spring pin.

ac. Remove lever arm holding block.

- ad. Remove gear drive assembly from setup fixture.
- ae. Remount, but do not tighten, two end stop switches.
- af. Position quick release plunger adjustment jig (Figure 5-2) in front of home end stop switch over switch actuator button.
- ag. Rotate primary gear drive shaft until end stop switch lever rests against jig. Hold lever, jig, and end stop switch so that jig aligns face of end stop switch parallel with face of end stop switch lever. Tighten two screws which secure end stop switch to gear drive housing.

NOTE

When installing quick release plungers, apply a small amount of grade E loctite per MIL-S-22473B to the threads.

- ah. Insert home quick release plunger in threaded hole in end stop switch lever. While maintaining lever jig, and end stop switch tight against each other as in step ag, slowly screw in quick release plunger until end stop switch produces an audible click as it actuates.
- ai. Remove jig and position it in front of far end stop switch over switch actuator button. Repeat steps ag and ah for far end stop switch, then remove jig.
- aj. Steps ak and al need be performed only for the inductor gear drive assembly.
- ak. Remount microswitch assembly using hardware removed in Step (p).
- al. Setup the microswitch assembly using Test Set paragraph 5-15, page 5-4.
- am. Rotate primary shaft assembly over entire range one or two times to assure smooth operation, free from binding.

CAUTION

Always provide mechanical support for hub of coupling on capacitor or inductor shaft when removing or inserting pins to prevent damage to shaft.

- an. Slide a metal bar underneath coupling for mechanical support, and drive out pin securing coupling to lead screw of capacitor (or rotor shaft of inductor). Remove coupling and place it on end of primary shaft of gear drive assembly. Align flats on primary shaft with set screws; apply grade E loctite per MIL-S-22473B to set screws before tightening.

ao. Set capacitor to its home position according to paragraph 5-29 steps i and j, or set inductor rotor to its home position according to Table 5-2.

ap. Carefully rotate primary shaft on gear drive assembly in home direction until end stop switch for home position just actuates. Set gear drive assembly on to coupler chassis.

aq. Without disturbing setting of potentiometer, carefully set potentiometer in place, engaging potentiometer shaft in hub of end stop switch lever. (Potentiometer shaft may have to be adjusted slightly.) Secure potentiometer bracket using two screws removed in step h.

*EIB 819*

Note

~~When installing the inductor gear drive assembly, the insert for the coupling on the end of the tripper shaft must be installed at the same time the primary shaft is engaged.~~

ar. Slide gear drive assembly into position to engage coupling. Secure gear drive assembly to coupler chassis using the three machine screws removed in step f.

CAUTION

Always provide support for the coupling and shaft when drilling and pinning. Always drill a new pin hole, unless old pin hole aligns perfectly. Always drill new pin hole at an angle which will prevent old pin hole from interfering with locking action of new pin.

as. Drill and pin coupling using a 0.0625 drill and an MS51987-71 spring pin.

at. Secure diode or terminal board to side of gear drive housing using the two machine screws removed in step e. If removed, replace fan and secure with original four screws.

au. Resolder wires removed in step i to end stop switches.

av. Place motor on chassis and resolder wires removed in step j. Do not engage motor with gear drive assembly.

aw. Set Mode Selector switch at MANUAL, then POWER switch at ON.

ax. With servo motor disengaged from gear drive assembly, use RIGHT and LEFT pushbuttons to actuate servo motor. At same time, rotate gear drive assembly by hand to both extremities to check that end stop switches function correctly to interrupt motor at limits of gear train tuning range.

ay. Slide servo motor into slot in gear drive housing. Replace and secure servo motor clamp using the four screws removed in step l.

az. Using RIGHT and LEFT pushbuttons, carefully "nudge" servo motor a few turns at a time over complete tuning range to recheck proper operation of end stop switches and potentiometer.

Note

Perform step ba only when repairing the inductor gear drive assembly.

ba. Repeat step az and note where coil rotor stops at both extremities. Refer to table 5-2, and if necessary, re-tweak quick release plungers so that rotor stops in the positions described in table 5-2. (Stopping position of rotor contact arm may change due to inertial overrun.)

TABLE 5-2. POSITION OF CONTACT ARM OF VARIABLE INDUCTOR ROTOR

CONDITION	COIL TURNS FROM HOME END
Home position	0.5 turns (180° from coil end)
Far end stop position	37.5 turns (270° from coil end)

bb. If no further servicing is to be done, replace chassis in case by performing the steps of paragraph 5-23 in reverse order.

bc. Replace cover on case by performing steps m through p of paragraph 5-9.

5-27. END-STOP SWITCH REPLACEMENT. To replace an end stop switch on either gear drive assembly, proceed as follows:

- a. Perform steps a through m of paragraph 5-26.
- b. Remove damaged end stop switch.
- c. Set new (replacement) end stop switch in position, but do not tighten two mounting screws.
- d. Position quick release plunger adjustment jig (figure 5-2) in front of replaced end stop switch over the switch actuator button.
- e. Rotate primary shaft until end stop switch lever is against the jig. Hold lever, jig, and end stop switch so that jig aligns face of end switch parallel with face of lever. Tighten screws securing end stop switch.
- f. Remove jig.
- g. Rotate gear train to set end stop switch lever against home end stop switch (lever will be maximum counterclockwise for inductor gear drive assembly, or maximum clockwise for capacitor gear drive assembly).
- h. Ensure tuning element is at home; steps i and j of paragraph 5-29 for variable capacitor or table 5-2 for variable inductor.

- i. Set gear drive assembly on coupler chassis.
- j. Resolder leads to end stop switch.
- k. Without disturbing setting of potentiometer, replace potentiometer bracket on side of gear housing, carefully engaging potentiometer shaft in hub of end stop switch lever. (Potentiometer shaft may have to be adjusted slightly.) Use original hardware to secure.
- l. Replace diode or terminal board, using original hardware to secure. If removed, replace fan and secure with original four machine screws.
- m. Slide gear drive assembly into position to engage primary shaft with coupling. (If inductor gear drive assembly is being reinstalled, replace coupling insert on tripper arm shaft). If required, adjust primary shaft slightly to align flats on shaft with set screws in coupling. Apply Grade E loctite per MIL-S-22473B and tighten set screws on coupling.

NOTE

For adjusting the quick release plungers which actuate the end stop switches, a pair of pliers with brass jaws may be used, or a small tool may be fabricated (paragraph 5-37).

n. Rotate gear drive assembly primary shaft by hand to check setting of quick release plunger on replaced end stop switch. Paragraph 5-29 steps i and j describe the capacitor home position. The capacitor far end stop position is 22 turns from the home position. Table 5-1 lists end stop positions for the inductor. Adjust end stop positions slightly if necessary.

o. Perform steps aw through bc of paragraph 5-26.

5-28. DAMPING RELAYS REPLACEMENT. To replace the microswitch on the inductor gear drive assembly, proceed as follows:

- a. Using a small offset screwdriver, remove and set aside the screws securing microswitch (1A1S2) FIG 5-4.
- b. Unsolder the wires from the microswitch. Discard the defective switch.
- c. Connect wires to new switch. Install switch using the roller and hardware removed in step (a).
- d. Remove and set aside the four screws securing the servo motor clamp. Slide the motor out of the gear housing. The motor leads need not be disconnected.
- e. Disconnect the wire from the microswitch at the 28vdc side of the thermal switch (1A2S1) FIG. 5-4.
- f. Manually drive the Inductor gear drive assembly until the arm of the coil rotor containing the contacts is positioned  $\frac{1}{2}$  turn to its home end from the 15th turn. That is  $\frac{1}{2}$  turn from the Damping Relay (1A2K2) soldered connection.
- g. Connect an Ohmmeter between the wire disconnected in step (e) and ground.

h. Loosen the two screws securing the microswitch so that it can be moved for adjustment. Adjust the switch away from the cam to the point that the Ohmmeter shows Infinite resistance. The Ohmmeter scale of RX100 is adequate.

i. Manually drive the Rotor toward the 1A2K2 solder connection until the Ohmmeter shows approximately 600 ohms. Turn the drive shaft to move the Rotor back several turns towards the Home end. The Ohmmeter should drop to Infinity and then as the Rotor is turned back towards the solder connection the reading should go to 600 ohms when the Rotor contacts are within  $\frac{1}{4}$  turn of the connection.

REPEAT STEPS (f) through (i) until the contact makes and breaks about the point of the connection of relay 1A2K2.

j. Reconnect the wire disconnected in Step (e) and re-install the servo motor using the clamp and hardware removed in Step (d).

k. To replace a Damping Relay (1A2K2 or 1A2K3) FIG 5-7 on the Coil Inductor assembly, proceed as follows.

l. Using a 25 or 40 watt soldering pencil heat the ribbon solder connection at the middle terminal of the relay and slide the folded ribbon off the terminal. Repeat for both relays leaving the ribbon attached to the coil turns.

m. Locate the screw securing the ground wire lug to the chassis directly under the relay assembly. Remove and retain the screw and washers.

n. Using a socket handle nut driver remove the two nuts securing the relay bracket assembly board to the coil spacer bar. Set aside the nuts and washers removed. Unsolder the ground buss connection to the defective relay. Unsolder the coil wires to the defective relay. Bend over the two relay coil terminals and while holding the bracket assembly in both hands press on the coil terminal end of the relay with both thumbs and remove the relay from the board. Discard relay.

o. Remove the remaining RTV silicone rubber from the inside of the hold. The fiberglass board should be inspected for dirt, grease and signs of burning. Clean the board with trichloroethylene or equal solvent dampened paper wiper. Burns can be scraped off the board and then coated with varnish or clear glyptal. The board should always have a glossy varnish type coating to repel moisture and dust. Allow any new coat of varnish to dry overnight before proceeding.

p. Using silicone rubber type RTV 102 or similar coat the inside of the hole for the relay and apply a small amount around the flange of the relay. Insert the relay into the hole and seat it snugly. Wipe off the excess RTV rubber that squeezes out on both sides of the board. Allow the RTV rubber to cure. Reconnect the coil connections. Mount the board with the nuts and washers removed in 3 above. Resolder the ribbon to the middle relays terminal by hooking over the lug and adding solder.

5-29. VARIABLE CAPACITOR REPLACEMENT. To replace the variable capacitor, proceed as follows:

a. Run variable capacitor to home position by setting Mode Selector switch at AUTO, then PRIMARY POWER switch at ON.

CAUTION

Always provide mechanical support to coupling when removing or inserting pins to prevent damage to shafts.

- b. Slide a short metal bar under coupling to provide support, and drive out pin securing coupling hub and capacitor lead screw.
- c. Loosen clamping screws on both rear and front mounting flanges.
- d. Remove and set aside two mounting bolts supporting each (front and rear) metal mounting flange.
- e. Slide front mounting flange (one nearest antenna terminal) off from end of variable capacitor.
- f. Carefully slide variable capacitor away from gear drive assembly to disengage coupling from lead screw.
- g. Lift variable capacitor slightly and slide it forward out of rear mounting flange.
- h. Discard faulty variable capacitor.
- i. Turn shaft on new capacitor counterclockwise until lead screw begins to disengage and lead screw housing becomes loose.
- j. Turn lead screw clockwise until housing just seats firmly, then turn an additional one-quarter turn.
- k. Hold replacement capacitor so that nipple on glass envelope is down, and carefully slide lead screw end through rear mounting flange and into position.
- l. Slide front mounting flange over end of capacitor.
- m. Position front and rear mounting flanges on capacitor, and engage lead screw in coupling carefully so that capacitor lead screw setting obtained in step j is not disturbed.
- n. Replace front and rear mounting flange mounting bolts removed in step d.
- o. Ensure that capacitor lead screw is installed properly in coupling, then tighten clamping screw on each mounting flange.
- p. Using a 0.0625 drill, carefully drill and pin coupling and lead screw. Use a short metal bar underneath coupling for mechanical support when driving in pin. If original pin is damaged, use and MS-51987-71 spring pin for replacement.
- q. If no further servicing is to be accomplished, perform steps m through p of paragraph 5-9.

5-30. VARIABLE INDUCTOR REPLACEMENT. To replace the inductor rotor assembly, or entire inductor assembly, perform all steps below. If inductor ground strip must be replaced, the necessary steps (which are obvious) can be performed without removing inductor from chassis.



Note

When replacing screws during assembly, place flat washer next to plastic, then place lockwasher on top between flat washer and nut or screw head.

- a. Set Mode Selector switch at AUTO, then POWER switch at ON. Allow inductor time to run home.
- b. Set POWER switch at OFF.
- c. Disconnect leads to variable capacitor and antenna feedthru from terminals on inductor (figure 5-4).
- d. Tag and disconnect lead from thermal switch S1 (located in inductor end support nearest gear drive assembly).
- e. Lightly mark flat of rectangular inductor drive shaft which faces contact arm of triangular rotor assembly. Also mark position of rotor contact on coil.

CAUTION

Always provide mechanical support to coupling when removing or inserting pins to protect shafts.

- f. Slide a small metal bar underneath coupling for support, and drive out pin through coupling and inductor drive shaft.
- g. Remove and set aside screw securing ground strap to chassis (figure 5-4).  
Remove and set aside eight machine screws securing variable inductor assembly to chassis.
- h. Carefully slide variable inductor assembly away from gear drive assembly to disengage coupling. Lift variable inductor assembly off from chassis. Set aside plastic insert from the coupling on shorting lever arm.
- i. Remove end support (the one on which ground strap is mounted) by removing brass screw and nut from each of the four support bars.
- j. Slide rotor assembly from shaft and discard defective part. Be sure to save spring washers.
- k. Examine replacement rotor assembly, noting that it is constructed of one piece of Fiberglas material to form a triangular shape with three arms which touch the coil. One arm contains the metal contact, the other two are guide slots.
- l. Orient rotor assembly with inductor shaft such that the contact arm is opposite the marked flat on shaft with contacts facing removed end piece. Slide rotor onto the shaft.

m. Replace end support assembly. Use one brass machine screw, two flat washers, and a lock washer to attach each support bar to end support. Place one flat washer under screw head, place other flat washer and lock washer under nut, with flat washer next to plastic.

n. Engage rotor with coil so that arm with guide slot in one piece is first, followed by guide slot between two pieces, and then contact arm last. Rotate rotor counterclockwise until contact is at mark on coil.

o. Set inductor assembly on main chassis.

p. Carefully engage inductor drive shaft in coupling. Replace insert in coupling on shorting arm lever.

q. Ensure that both couplings are properly engaged. Secure inductor assembly to chassis by replacing eight machine screws removed in step i.

r. Slide a metal bar underneath coupling for mechanical support and pin (type MS51987-71) coupling and inductor shaft using original hole.

s. Replace machine screw securing ground strap to chassis.

t. Resolder leads to thermal switch S1.

u. Reconnect lead from variable capacitor to terminal on top inside support bar (side facing variable capacitor).

v. Reconnect lead from antenna terminal to terminal on bottom inside support bar.

w. Set Mode Selector switch at MANUAL, then POWER switch at ON.

x. Using LEFT and RIGHT pushbuttons, run gear drive to both extremities. Check that rotor stops as described in table 5-2. If necessary, "re-tweak" quick release plungers to ensure correct positioning of rotor.

y. Use the RIGHT and LEFT pushbuttons to traverse the rotor the length of the coil several times, and check that the shorting lever actuates within the range prescribed in table 5-2 and that when shorting lever is against coil, it is touching coil at a point 14.5 turns from the home end of coil.

z. Set POWER switch at OFF.

\* If no further servicing is to be accomplished, perform steps j through m of paragraph 5-9.

5-31. ANTENNA INSULATOR (1A1E1) MATERIAL

5-32. The Antenna Insulator (1A1E1) is manufactured from Beryllium Oxide.

CAUTION

Beryllium Oxide as delivered is harmless; however no physical alteration should be attempted without consulting the supplier or NAVSECNO DIV.

5-33. TEST CABLE FABRICATION.

5-34. To permit the CU-938/URA-38 to be serviced in proximity to the C-3698/URA-38 and transmitter, test cables that are approximately 10 feet long should be fabricated to replace system cables W2 and W3. Tables 2-1 and 2-3 provide all the information required for materials and connections. In addition, a test cable must be fabricated to perform the discriminator adjustment procedure. This cable should be a three foot length of RG-58/U with an UG-536B/U connector on one end. Strip the other end back no further than one inch. Separate center conductor and shield. Strip insulation from center conductor. Tin both center conductor and shield.

5-35. RF LOAD SIMULATOR FABRICATION.

5-36. An RF output dummy load must be fabricated for use during servicing of the CU-938/URA-38. Fabrication information for a suitable load of this type is provided in figure 5-14.

5-37. QUICK RELEASE PLUNGER ADJUSTMENT TOOL FABRICATION.

5-38. The quick release plungers in the endstop switch lever arm can be adjusted with a pair of brass jaw pliers. However, a slight modification to a small screwdriver will provide a tool which may be more convenient to use. Select a small screwdriver with a blade tip approximately 0.150 wide by 0.040 thick. In the center of the tip, cut a small notch, 0.060 wide and 0.075 deep.

5-39. TRANSISTOR VOLTAGE MEASUREMENTS.

5-40. Table 5-3 provides a listing of transistor DC voltage measurements. All readings were taken with a 20,000 ohms/volt meter and should be with  $\pm 20\%$  of the indicated values, unless otherwise specified. Set POWER switch at ON and Mode Selector at AUTO.

5-41. REPLACEMENT CASE FOR CU-938

5-42 The part numbers for the CU-938 case shown in the parts list are actually for the AN/URA-38A coupler, however, no problem exists since this case is identical except for the addition of several air flow passages. Utilization of these passages is recommended and can be accomplished by drilling several holes in the 1A2 chassis assembly beneath the 1A2L1 coil assembly.

Note

The voltage of the +28V supply varies considerably, from about +31 volts under quiescent condition to about +26 volts when the motors are running. Bear in mind that any voltage depending on the +28V supply for B+ will vary similarly with the motors stopped or running.

In the cross coupled amplifier stage of the two servo amplifier assemblies (2A1A1 and 2A1A2), the absolute value of the voltages may vary several volts depending on the amplitude of the discriminator error signal and the extent to which the motors load down the +28V supply. More important than the exact voltages themselves are the differences in polarity of base-to-emitter voltage between opposite sides of the amplifier; that is, which is being tuned on and which is held cut off. (The voltages in the chart were measured in a unit with about 300 MV error signals simulated from the discriminator.)

Voltages at A3Q5 and A4Q3 collectors depend on associated transmitter. Values shown in chart are for AN/URT-23(V).

TABLE 5-3. TRANSISTOR DC VOLTAGE MEASUREMENTS

TRANSISTOR	CONDITION	DC VOLTAGE TO GROUND			
		B	E	C	
Differential Amplifier (A1 or A2) Q3-Q5	No Input	Q3	0	- 0.60	22.8
		Q5	0	- 0.60	22.8
	Tune Input	Q3	0	- 0.65	13.0
		Q5	- 0.37	- 0.77	13.6
	Home Input	Q3	0	- 0.38	13.6
		Q5	0.32	- 0.27	13.0
Cross-Coupled Amplifier (A1 or A2) Q4-Q6	No Input	Q4	22.8	22.8	0
		Q6	22.8	22.8	0
	Tune Input	Q4	13.6	13.0	0
		Q6	13.0	13.6	2.5
	Home Input	Q4	13.0	13.6	2.5
		Q6	13.6	13.0	0
Capacitor Discharge Transistors (A1 or A2) Q9, Q10	No Input	Q9	0	0	0
		Q10	0	0	0
	Tune Input	Q9	0	0	0
		Q10	2.5	2.0	0
	Home Input	Q9	2.5	2.0	0
		Q10	0	0	0

TABLE 5-3. TRANSISTOR DC VOLTAGE MEASUREMENTS (Cont)

TRANSISTOR	CONDITION	DC VOLTAGE TO GROUND			
		B	E	C	
Emitter Followers (A1 or A2) Q2, Q7	No Input	Q2	0	0	31.0
		Q7	0	0	31.0
	Tune Input	Q2	0	0	28.0
		Q7	2.0	1.3	1.4
	Home Input	Q2	2.0	1.3	1.4
		Q7	0	0	28.0
Drivers (A1 or A2) Q1, Q8	No Input	Q1	0	0	31.0
		Q8	0	0	31.0
	Tune Input	Q1	0	0	28.0
		Q8	1.3	0.5	0.7
	Home Input	Q1	1.3	0.5	0.7
		Q8	0	0	28.0
A3Q1	Key Up	1.2	0	0.5	
	Key Down	0	0	0	
A3Q2	L Motor Running	0.7	0	0.1	
	L Motor Off	- 2.0	0	0.8	
A3Q3	Motor(s) Stopped	0.75	0	0.2	
	Motor(s) Running, Initial Tune	0	0	18.0	
	Motor(s) Running After Initial Tune or to Home	0	0	14.0	
A3Q4	Motor(s) Stopped	- 0.9	0	31.0	
	Motor(s) Running, Initial Tune	1.6	0.9	1.1	
	Motor(s) Running After Initial Tune or to Home	- 0.4	- 0.7	28.0	
A3Q5	System Unkeyed	0	0	28.0	
	System Keyed by C-3698/URA-38 While Tuning	0.9	0	0.05	
	System Keyed External to C-3698/URA-38	0	0	0	
A3Q6	C Motor Running	0.7	0	0.1	
	C Motor Off	- 2.0	0	0.8	
A3Q7	L Motor Running	0.8	0	1.2	
	L Motor Off	0.2	0	31.0	
A3Q8	C Motor Running	0.8	0	1.2	
	C Motor Off	0.2	0	31.0	
A3Q9	Motors Stopped	1.3	0.7	0.8	
	Motor(s) Running	0	0	28.0	

TABLE 5-3. TRANSISTOR DC VOLTAGE MEASUREMENTS (Cont)

TRANSISTOR	CONDITION	DC VOLTAGE TO GROUND		
		B.	E	C
A4Q1	Retune (Element(s) Running Home) Otherwise	0.7 0 to - 1.0	0 0	0.1 9.0 to 13.0
A4Q2	Retune (Element(s) Running Home) Otherwise	0.1 0.7	0 0	14.0 0.1
A4Q3	System keyed, Either Tuning or Tuned System Unkeyed and/or Homing	- 0.7 0.7	0 0	11.0 0.1
A4Q4	Inductor at Home Tuning (Initial Tune) Otherwise	- 0.8 0.7 - 0.2 to - 0.9	0 0 0	0 0.1 4.0 to 6.2
A4Q5	Elements at Home or Tuning (Initial Tune) Otherwise	- 0.1 0.7	0 0	28.0 0.1
A4Q6	Tuned, With or Without RF Otherwise	0.8 - 0.1 to + 0.3	0 0	0.3 28.0
Motor Drive Transistors	Motors Stopped: Q1, Q2, Q3, Q4	31.0	31.0	31.0
	Q5, Q6, Q7, Q8	31.0	30.0	0
	Motors Running (C) (L) (Tune Direction)			
	Q1 or Q3 (Home +)	27.5	27.0	1.3
	Q2 or Q4 (Tune +)	26.5	27.0	27.0
	Q5 or Q7 (Tune -)	0.7	1.1	0
	Q6 or Q8 (Home -)	27.5	26.5	0
Motors Running (C) (L) (Home Direction)				
Q1 or Q3 (Home +)	27.0	27.5	27.5	
Q2 or Q4 (Tune +)	28.0	27.5	1.3	
Q5 or Q7 (Tune -)	28.0	27.0	0	
Q6 or Q8 (Home -)	0.7	1.1	0	

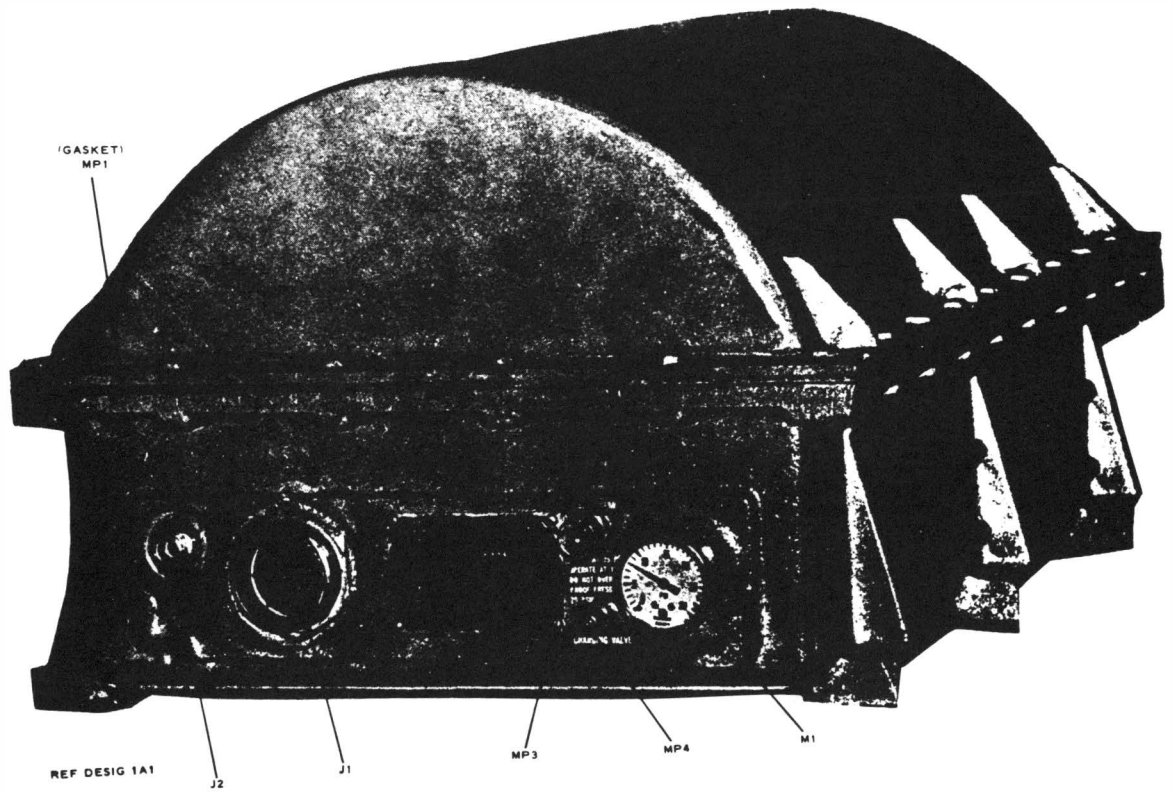
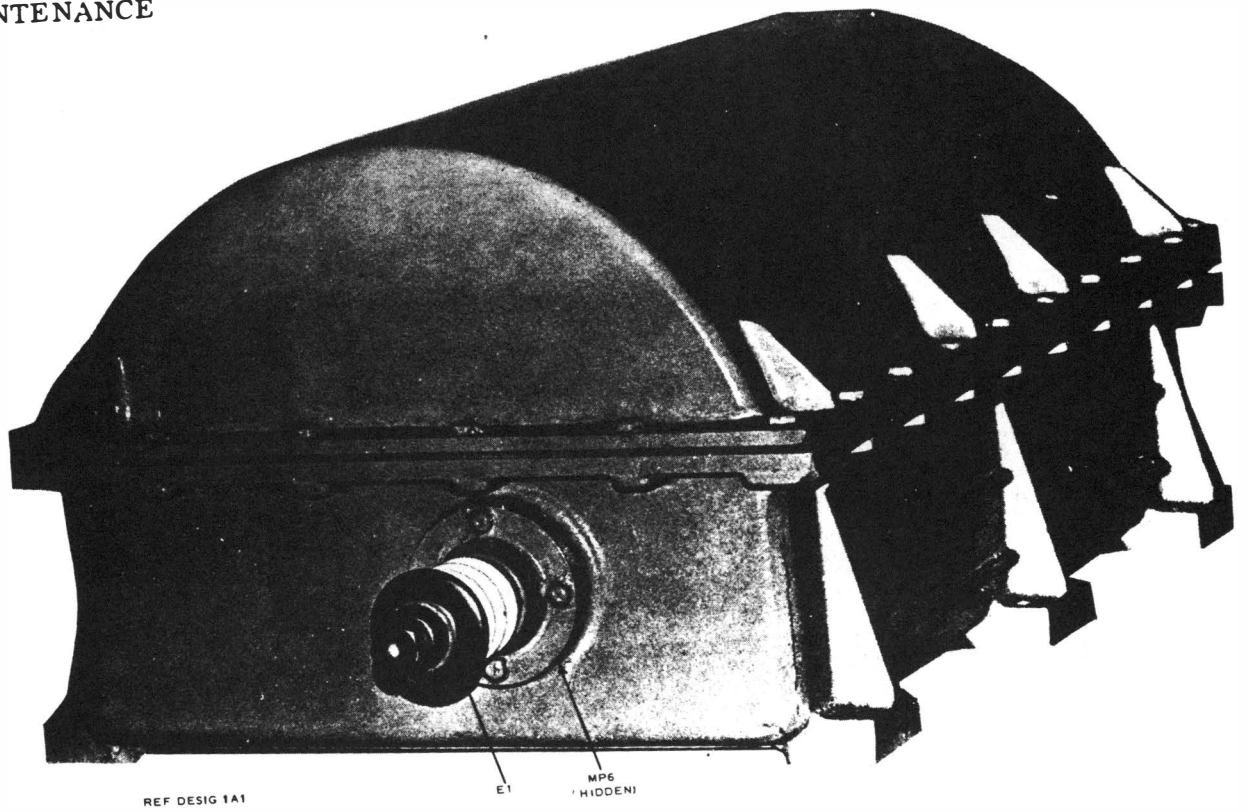

Figure 5-3. Antenna Coupler CU-938/URA-38, Case, Component Locations

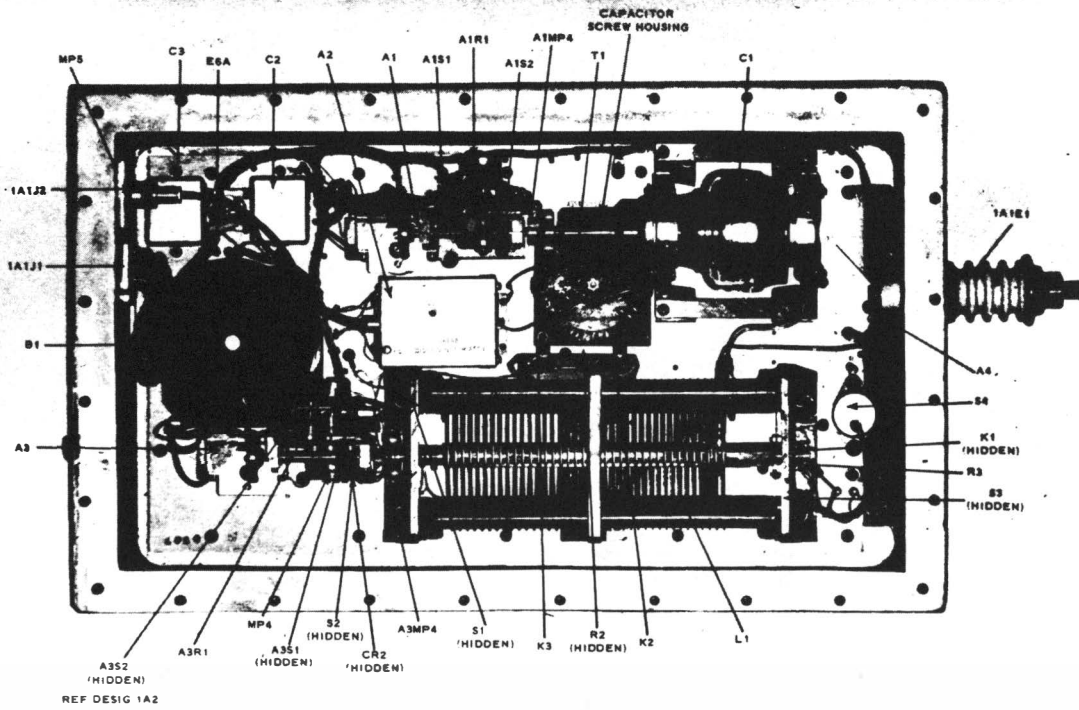

Figure 5-4. Antenna Coupler CU-938/URA-38, Chassis, Component Locations

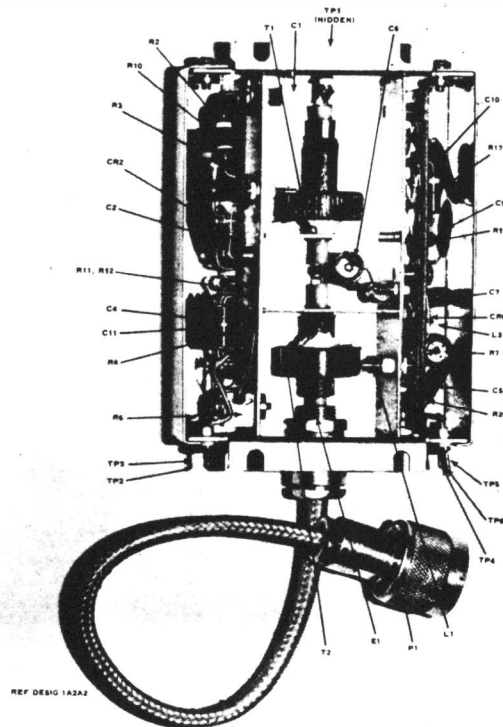

Figure 5-5. Discriminator Assembly 1A2A2, Component and Test Point Locations



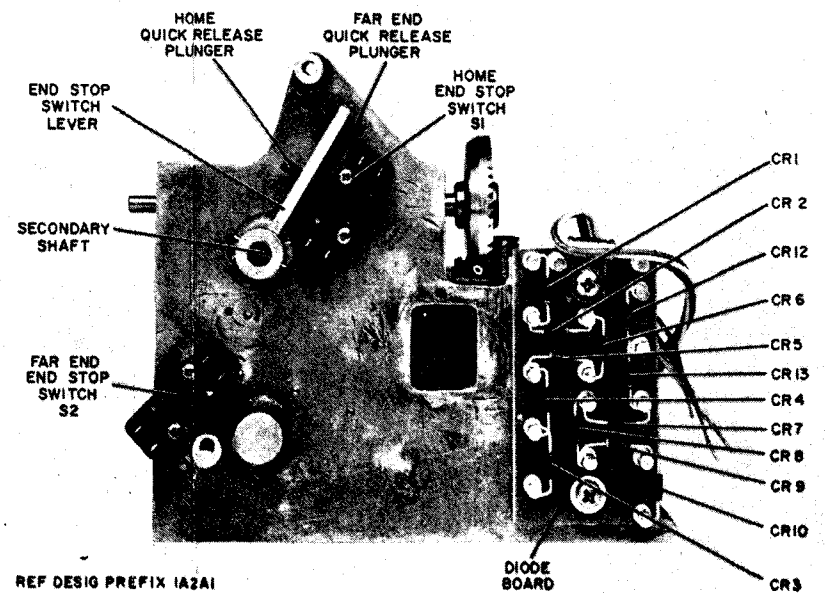
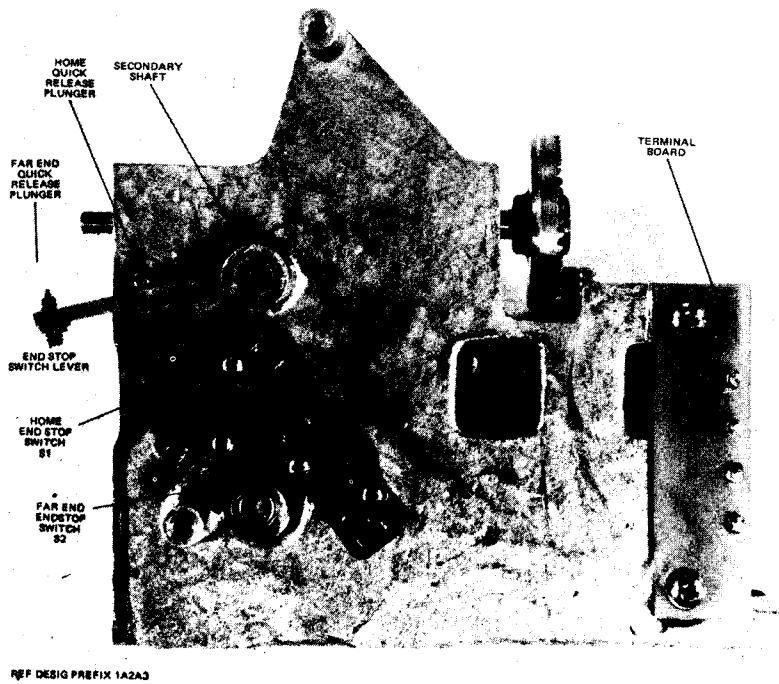
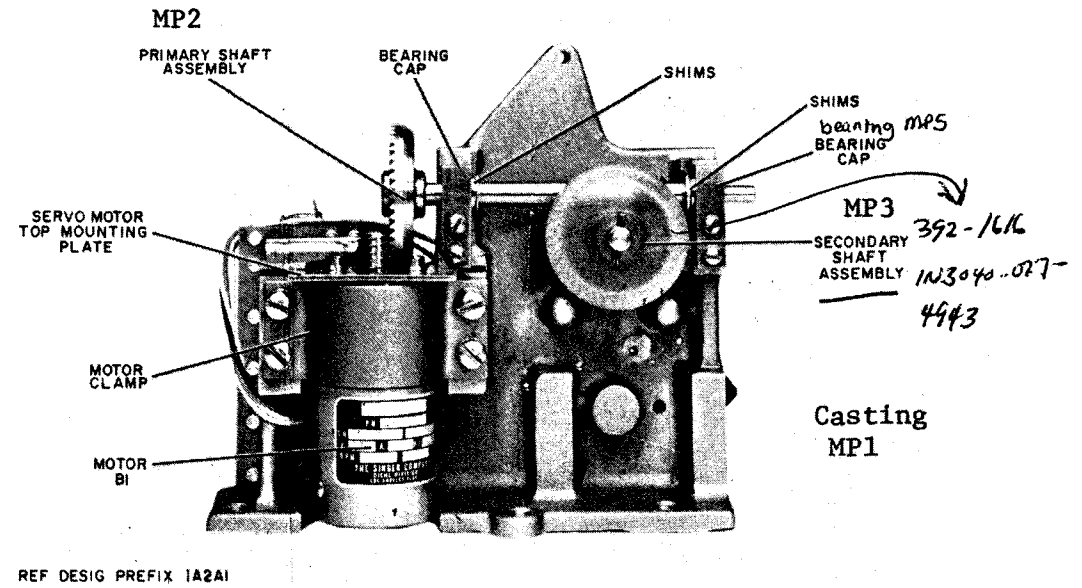
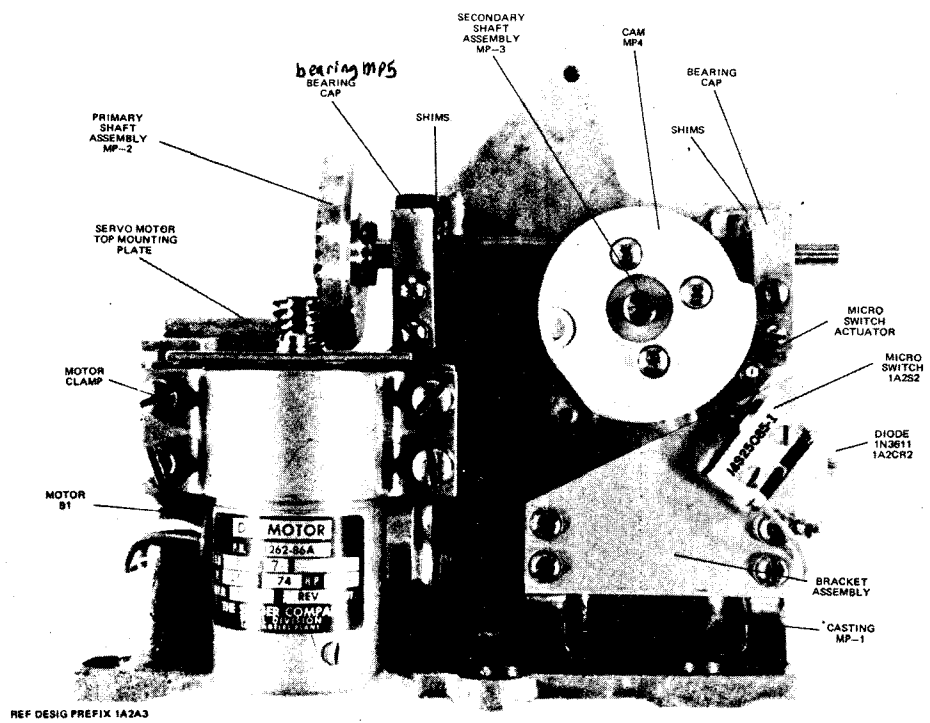

Figure 5-6. Gear Drive Assemblies 1A2A1 and 1A2A3, Component Locations

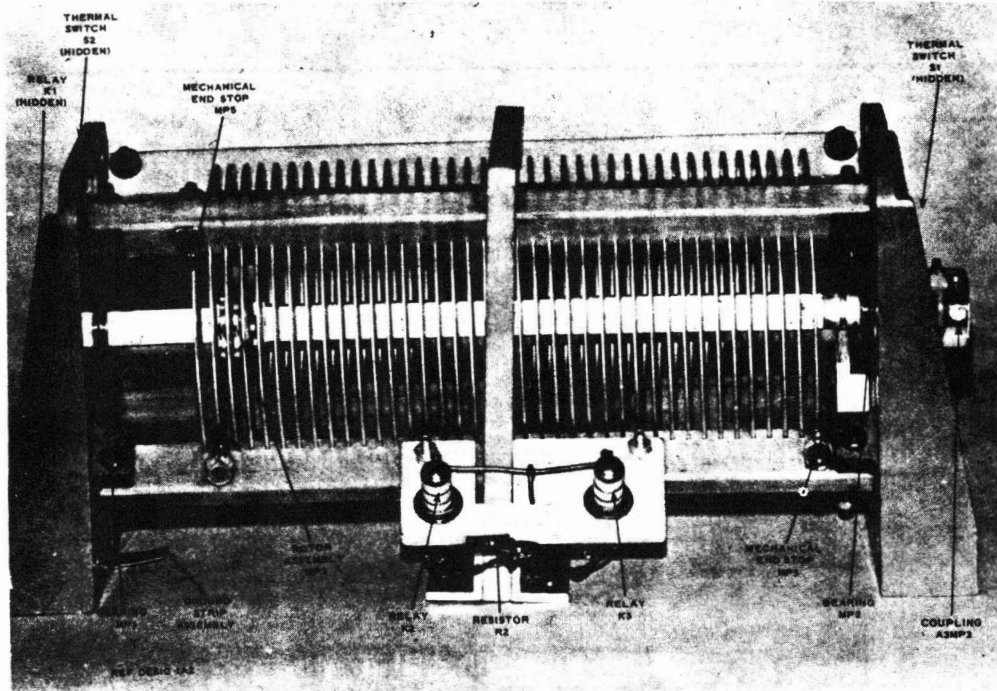
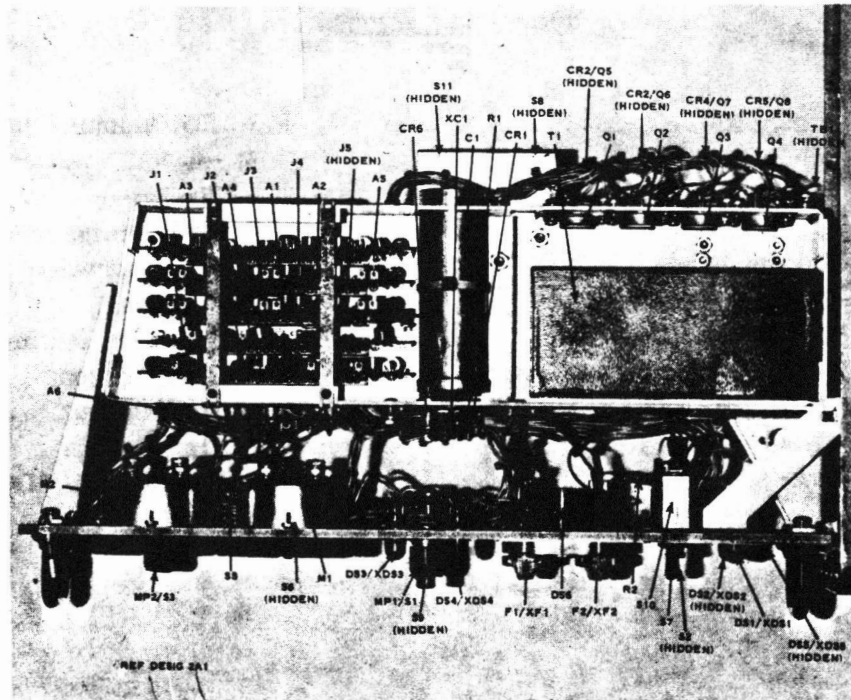
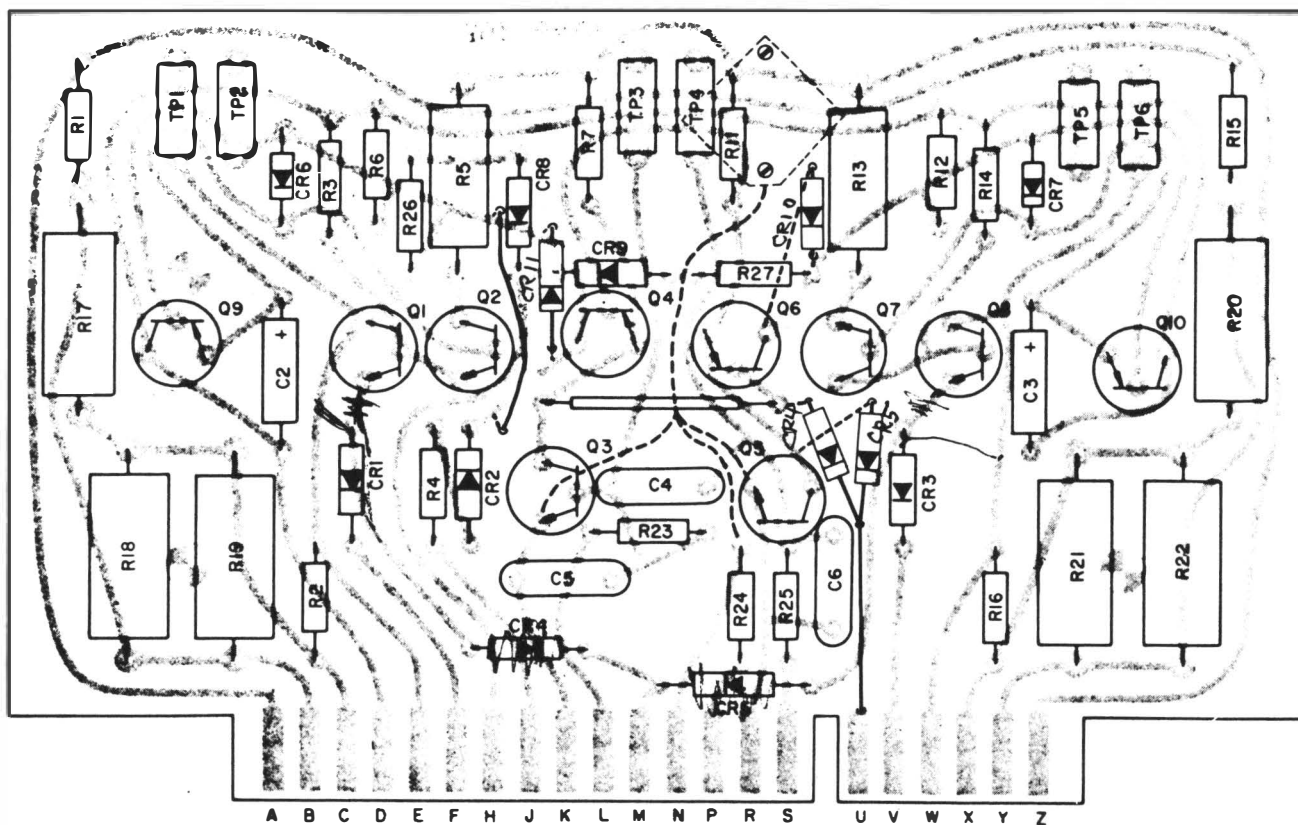

Figure 5-7. Inductor Assembly 1A2L1, Component Locations





REF DESIG PREFIX  
2A1A1 or 2A1A2

PIN CALLOUTS

- |                            |                         |
|----------------------------|-------------------------|
| A - +28 VDC                | N - To Balance Pot      |
| B - Home Output            | P - -4 VDC              |
| C - Home Output            | R - To Balance Pot      |
| D - Chassis Ground         | S - Discriminator Input |
| E - Home Output            | T - (T is keyway)       |
| F - Home Ground            | U - (not used)          |
| H - Tune Sensitivity In    | V - Tune Ground In      |
| J - Home Signal From Logic | W - Tune Output         |
| K - To Balance Pot         | X - Tune Output         |
| L - Discriminator Ref      | Y - Tune Output         |
| M - Automatic GRD          | Z - Switched 28 VDC In  |

Figure 5-9. Printed Circuit Boards 2A1A1 and 2A1A2, Component and Test Point Locations

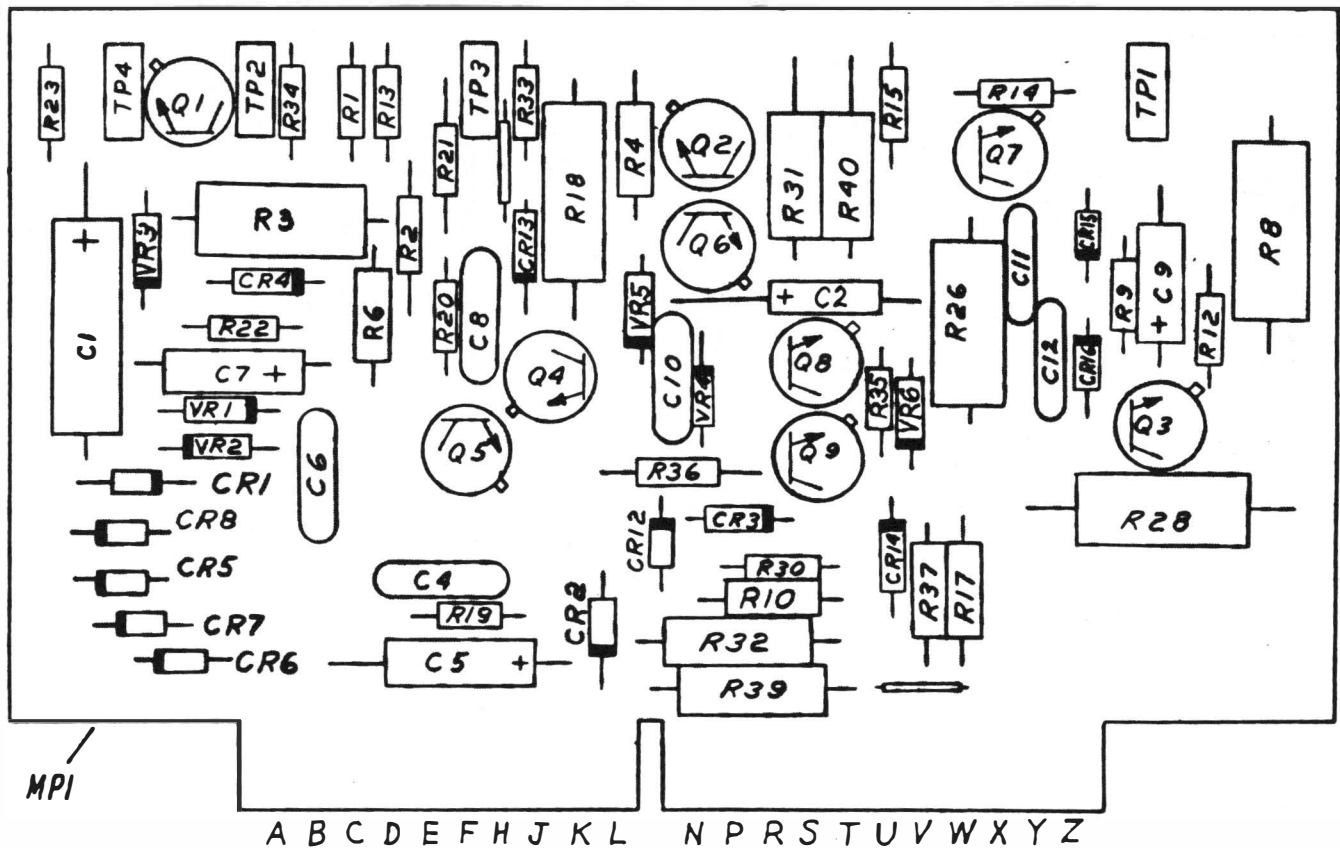

REF DESIG PREFIX  
 2A1A3

PIN CALLOUTS

- |                   |                        |
|-------------------|------------------------|
| A - 28 VDC        | N - 4 VDC Out          |
| B - 28 VAC        | P - To Tune Lamp       |
| C - 28 VAC        | R - C Motor On         |
| D - 4 VAC         | S - Element Pos. Meter |
| E - Bypass        | T - L Motor Brake      |
| F - 12.4 VDC      | U - Motor On           |
| H - Chassis GRD   | V - Element Pos. Pot.  |
| J - Key Hold      | W - 28 VDC             |
| K - Keyline       | X - -2 VDC Out         |
| L - L Motor On    | Y - C Motor Brake      |
| M - (M is Keyway) | Z - (not used)         |

Figure 5.10 . Printed Circuit Board 2A1A3, Component and Test Point Locations

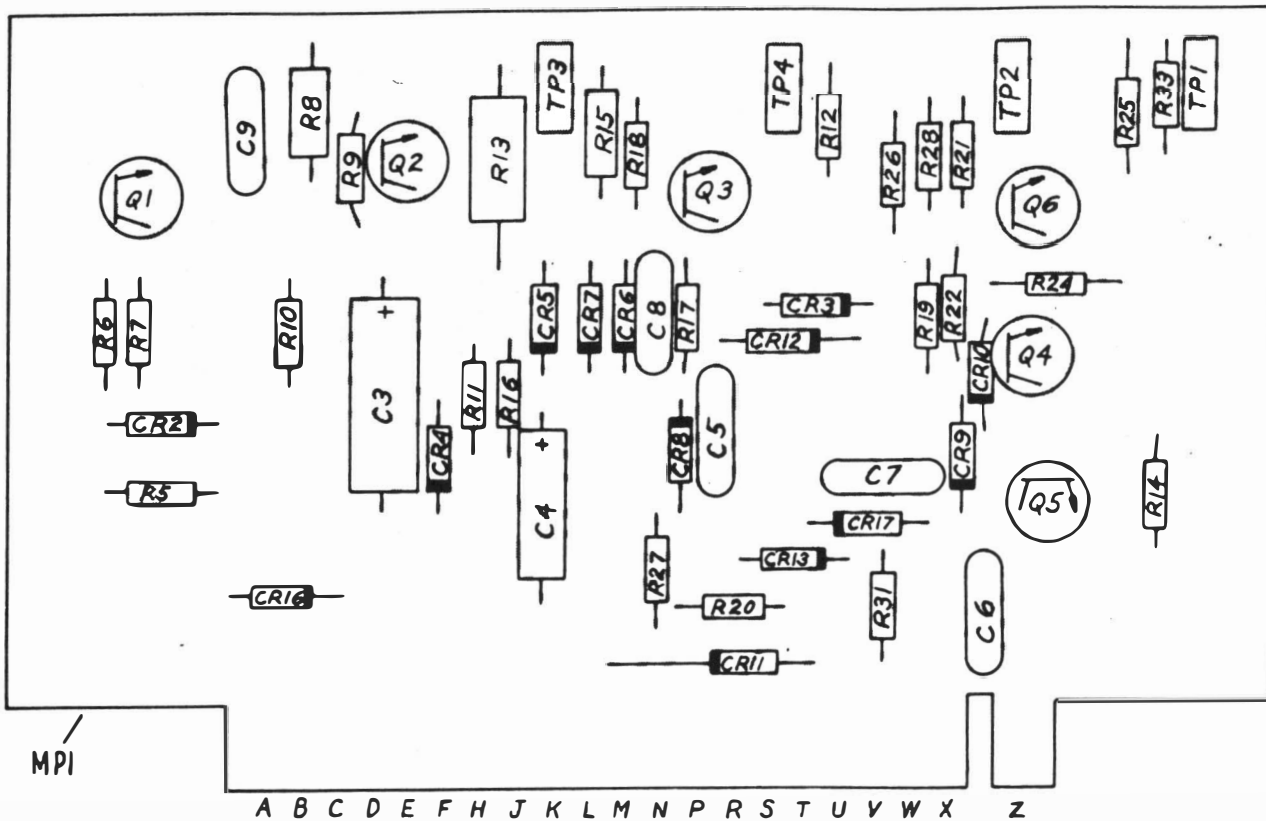

REF DESIG PREFIX  
2A1A4

PIN CALLOUTS

- |                        |                            |
|------------------------|----------------------------|
| A - 28 VDC             | N - Manual - Silent GRD    |
| B - -2 VDC             | P - +Null Meter            |
| C - GRD Pulse In       | R - Far End Stop In        |
| D - Home Signal Out    | S - Key Hold Out           |
| E - Keyline In         | T - Tune Sensitivity Drive |
| F - Key Interlock Out  | U - -Null Meter            |
| H - (not used)         | V - (not used)             |
| J - Motor On           | W - Ready Lamp Out         |
| K - Reset In           | X - Chassis GRD            |
| L - Discriminator Home | Y - (Y is Keyway)          |
| M - Overload In        | Z - (not used)             |

Figure 5.11. Printed Circuit Board 2A1A4. Component and Test Point Locations

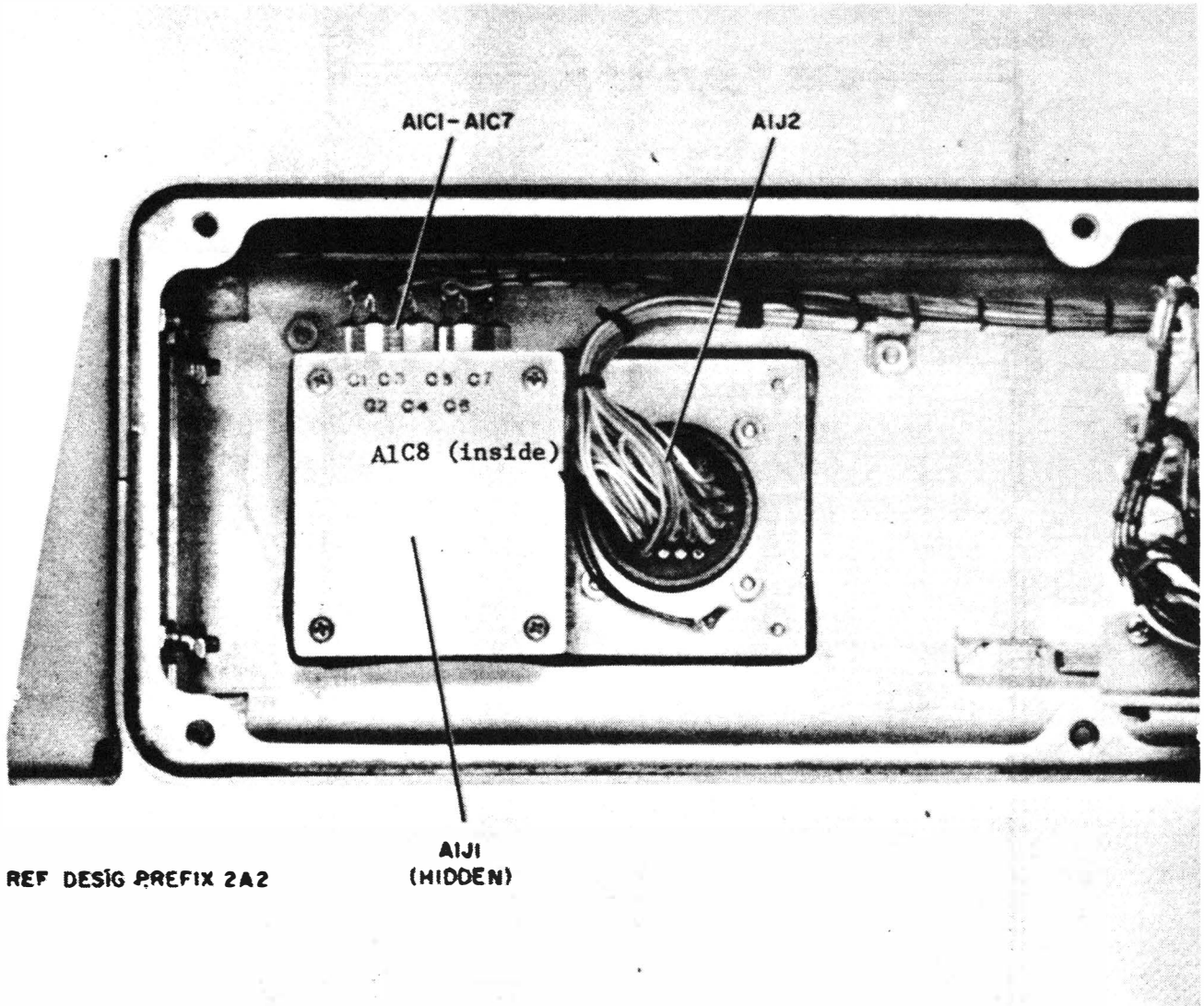

Figure 5-12. Antenna Coupler Control C-3698/URA-38, Case, Component Locations

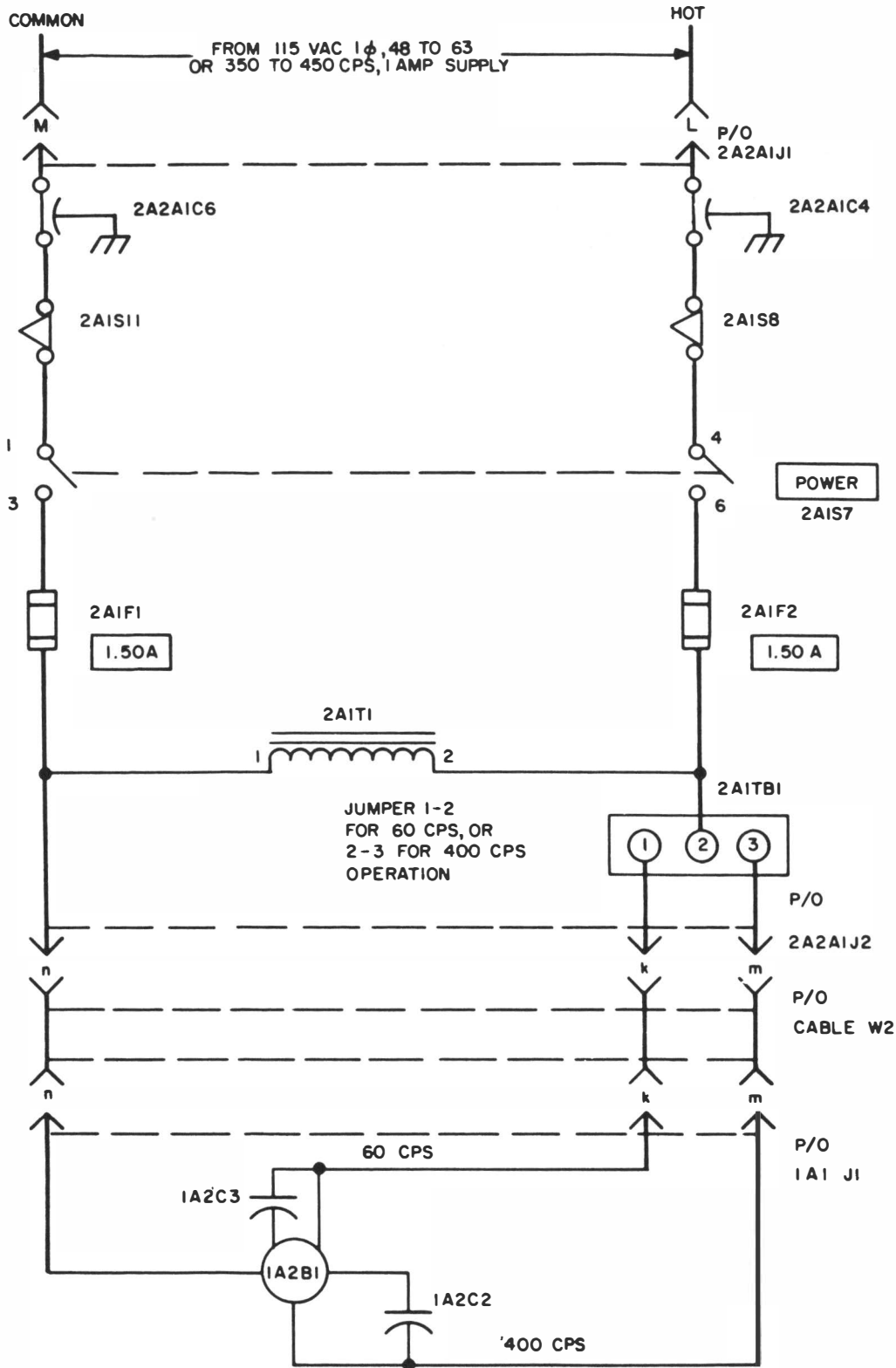
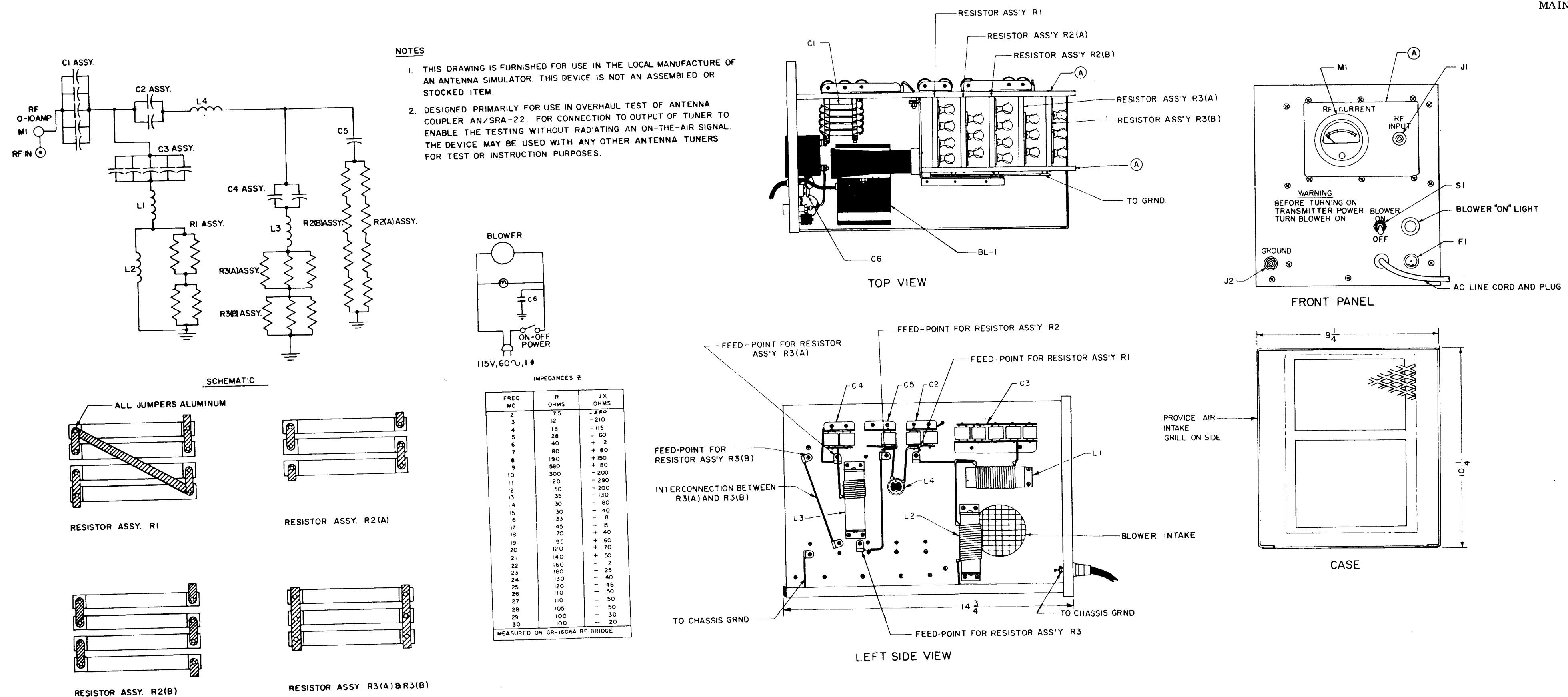

Figure 5-13. Primary Power Distribution Diagram





**NOTES**

1. THIS DRAWING IS FURNISHED FOR USE IN THE LOCAL MANUFACTURE OF AN ANTENNA SIMULATOR. THIS DEVICE IS NOT AN ASSEMBLED OR STOCKED ITEM.
2. DESIGNED PRIMARILY FOR USE IN OVERHAUL TEST OF ANTENNA COUPLER AN/SRA-22. FOR CONNECTION TO OUTPUT OF TUNER TO ENABLE THE TESTING WITHOUT RADIATING AN ON-THE-AIR SIGNAL. THE DEVICE MAY BE USED WITH ANY OTHER ANTENNA TUNERS FOR TEST OR INSTRUCTION PURPOSES.

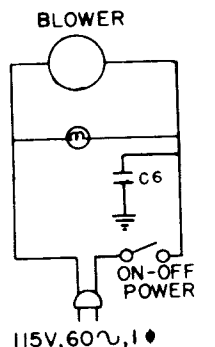

IMPEDANCES Z

FREQ MC	R OHMS	JX OHMS
2	75	-380
3	12	-210
4	18	-115
5	28	-60
6	40	+2
7	80	+80
8	190	+150
9	580	+80
10	300	-200
11	120	-290
12	50	-200
13	35	-130
14	30	-80
15	30	-40
16	33	-8
17	45	+15
18	70	+40
19	95	+60
20	120	+70
21	140	+50
22	160	-2
23	160	-25
24	130	-40
25	120	-48
26	110	-50
27	110	-50
28	105	-50
29	100	-30
30	100	-20

MEASURED ON GR-1606A RF BRIDGE

MATERIAL LIST		
ITEM	QTY.	DESCRIPTION
L1	1	COIL FORM - 1" DIA, CERAMIC, HOLLOW CENTER, 3" LONG - 6 FT. NO. 14 AWG WIRE, WITH NO. 14 TEFLON SLEEVING CLOSE WOUND 20 TURNS.
L2	1	COIL FORM - 1" DIA, CERAMIC HOLLOW CENTER, 3" LONG - 4 1/2 FT. NO. 14 AWG WIRE, WITH NO. 14 TEFLON SLEEVING CLOSE WOUND 15 TURNS.
L3	1	COIL FORM - 1" DIA, CERAMIC, HOLLOW CENTER, 3" LONG - 2 1/2 FT. NO. 14 AWG WIRE, WITH NO. 14 TEFLON SLEEVING CLOSE WOUND 8 3/4 TURNS.
L4	1	COIL FORM - 3/4" DIA, CERAMIC, HOLLOW CENTER, 1 1/2" LONG - 1 FT. NO. 14 AWG NO INSULATION, UNIFORMLY WOUND 2 1/4 TURNS (APPROX. 1/16" BETWEEN EACH TURN)
C1 ASSY	5	CAPACITOR, MICA, 220MMFD, FLAT, 2500VDC - AEROVOX CORP. OR CORNELL DUBILIER TYPE CM 45B221 - CONNECTED IN PARALLEL.
C2 ASSY	1	CAPACITOR, CERAMIC, 25MMFD, 5000 VDC, CENTRALAB 850S-25Z AND CAPACITOR, CERAMIC 100MMFD, 5000VDC, CENTRALAB 850S-100N CONNECTED IN PARALLEL.
C3 ASSY	3	CAPACITOR, CERAMIC, 25MMFD, 5000VDC, CENTRALAB 850S-25Z AND CAPACITOR, CERAMIC, 20MMFD, 5000VDC, CENTRALAB 850S-20Z CONNECTED IN PARALLEL.
C4 ASSY	1	CAPACITOR, CERAMIC, 50MMFD, 5000VDC, CENTRALAB 850S-50Z AND CAPACITOR, CERAMIC, 12MMFD, 5000VDC, CENTRALAB 850S-12Z CONNECTED IN PARALLEL.
C5	1	CAPACITOR, CERAMIC, 47MMFD, 5000VDC, CENTRALAB 850S-47Z
C6	1	CAPACITOR - MICA, .01MFD
R1 ASSY.	4	RESISTOR, 50 OHM, 22 WATT, GLOWBAR TYPE CX WITH CLIPS MOUNTED ON 1/4" THICK PLASTIC-GLASS EPOXY RESIN MOUNTING PLATE TYPE G, PER MIL-P-18177.
R2 ASSY.	7	
R3 ASSY.	6	
MI	1	0-10 AMP RF AMMETER, SIMSON MR 25W0IORLAA, MODEL 136
J1	1	RF INPUT TERMINAL, SUPERIOR TYPE DFN 30RC
J2	1	BINDING POST - BLACK, SUPERIOR TYPE DFN 30BC
S1	1	TOGGLE SWITCH, 10AMP
F1	1	FUSE HOLDER, BUSSMAN HKP-HJR.
BL-1	1	BLOWER MOTOR - HEINZE ELECTRIC CO., D-52199
(A)	1	MOUNTING PLATES, PLASTIC-GLASS EPOXY RESIN, TYPE G PER MIL-P-18177, 1/4" THICK.

ALL BUSS WIRE IS NO 14 AWG, TIN COATED COPPER.  
BLOWER MOTOR TO DUCT AIR ACROSS 50 OHM RESISTORS AND EXHAUST THROUGH REAR OF CASE. AIR INTAKE IS ON LEFT SIDE OF CASE  
COIL FORMS AVAILABLE FROM CENTRALAB.

Figure 5-14. RF Load Simulator, Fabrication Diagram



NOTES

1. PREFIX PARTIAL REFERENCE DESIGNATIONS WITH 1A2 PLUS SUB-ASSEMBLY NUMBER, IF ANY.
2. UNLESS OTHERWISE SPECIFIED
  - A. ALL RESISTANCE VALUES ARE IN OHMS; K INDICATES THOUSANDS OF OHMS
  - B. ALL RESISTORS ARE  $\frac{1}{2}$  W  $\pm 5\%$
  - C. ALL DIODES ARE 1N3611
  - D. ALL CAPACITANCE VALUES ARE IN PICO FARADS
  - E. ALL INDUCTANCE VALUES ARE IN MICROHENRIES

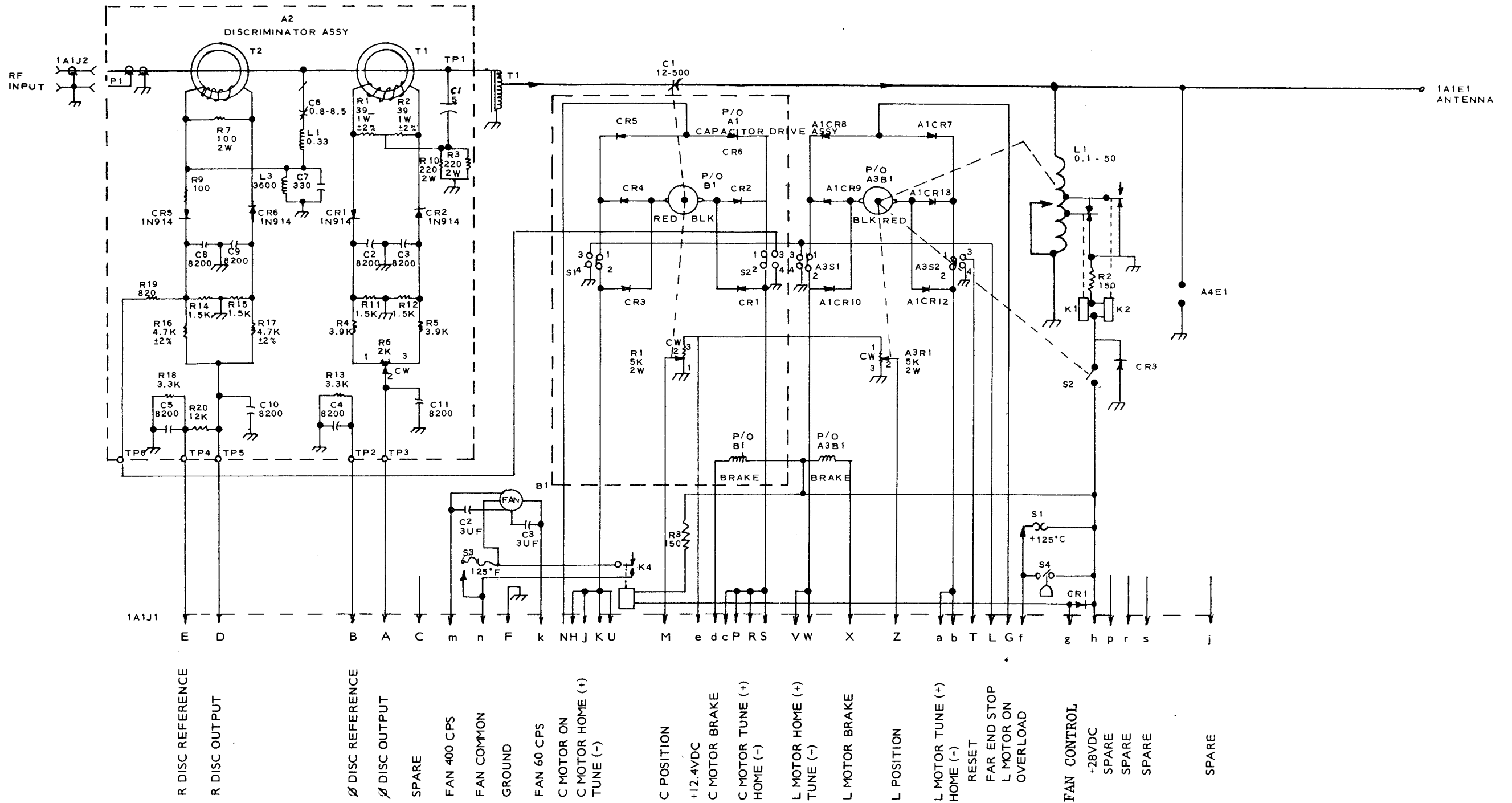

CHANGE 3

Figure 5-15. Antenna Coupler CU-938/  
URA-38, Schematic Diagram

PARTS LOCATION INDEX

REF DESIG	LOC	REF DESIG	LOC	REF DESIG	LOC	REF DESIG	LOC	REF DESIG	LOC
C1	14C	A1C5	35C	A2Q1	40H	A3Q7	9F	A4Q3	19E
		A1C6	35C	A2Q2	39H	A3Q8	9G	A4Q4	17D
CR1	50E			A2Q3	35H	A3Q9	9D	A4Q5	19D
CR2	50D	A1CR1	40C	A2Q4	37H			A4Q6	19F
CR3	50B	A1CR2	36A	A2Q5	35F	A3R1	8B	A4R5	16H
CR4	50F	A1CR3	40D	A2Q6	37F	A3R2	8B	A4R6	16H
CR5	50H	A1CR4	40C	A2Q7	39F	A3R3	11F	A4R7	17H
		A1CR5	40D	A2Q8	40F	A3R4	6F	A4R8	17G
DS1	15F	A1CR6	38B	A2Q9	38H	A3R6	12C	A4R9	18H
DS2	15C	A1CR7	38D	A2Q10	38F	A3R8	10D	A4R10	17G
DS3	5D	A1CR8	37C			A3R9	10G	A4R11	18G
DS4	21G	A1CR9	38D	A2R1	40H	A3R10	7D	A4R12	18G
DS5	23G			A2R2	40H	A3R12	9D	A4R13	20H
DS6	24F			A2R3	39H	A3R13	8B	A4R14	20G
		A1Q1	40B	A2R4	35I	A3R14	12C	A4R15	17E
F1	4B	A1Q2	39B	A2R5	39H	A3R15	7H	A4R16	18F
F2	4C	A1Q3	35B	A2R6	37H	A3R17	6G	A4R17	19E
		A1Q4	37B	A2R7	36H	A3R18	8E	A4R18	19F
		A1Q5	35D	A2R8	37F	A3R19	8F	A4R19	19D
J1	34G, 34C, 5B, 5C-H, 13D-G	A1Q6	37D	A2R11	37F	A3R20	7E	A4R20	29E
J2	29E, 29F, 34E, 33I, 33B, 45E, 15D-I, 18C, 21D-H	A1Q7	39D	A2R12	38F	A3R21	7F	A4R21	17D
		A1Q8	40D	A2R13	39F	A3R22	8F	A4R22	16D
		A1Q9	38B	A2R14	39F	A3R23	6B	A4R24	19D
		A1Q10	38D	A2R15	41F	A3R26	11G	A4R25	20D
J3	34B-D, 37C, 42B-D, 38E, 39E, 40E	A1R1	40B	A2R17	40H	A3R28	11G	A4R26	18D
		A1R2	40B	A2R18	41H	A3R30	9D	A4R27	20F
		A1R3	39B	A2R19	41H	A3R31	8F	A4R28	16G
J4	34F-H, 36C, 38E, 39E, 40E 42G-I	A1R4	35A	A2R20	41F	A3R32	8G	A4R31	29F
		A1R5	39B	A2R21	41F	A3R33	7G	A4R33	19D
		A1R6	38B	A2R22	41F	A3R34	10C		
		A1R7	36B	A2R23	35H	A3R35	8D	A4TP1	18D
M1	5I	A1R8	37D	A2R24	35G	A3R36	7D	A4TP2	16G
M2	30F	A1R11	37D	A2R25	35G	A3R37	6H	A4TP3	20H
		A1R12	37D	A2R26	37H	A3R38	6D	A4TP4	19E
		A1R13	39D	A2R27	38F	A3R39	8G		
Q1	50B	A1R14	39D			A3R40	8F	2A2A1C1	14H
Q2	50D	A1R15	41C	A2TP1	41H			2A2A1C2	14E
Q3	50G	A1R16	41D	A2TP2	38H	A3TP1	12C	2A2A1C4	3C
Q4	50E	A1R17	40B	A2TP3	35H	A3TP2	10C	2A2A1C5	22E
Q5	50D	A1R18	41B	A2TP4	35H	A3TP3	8C	2A2A1C6	3B
Q6	50C	A1R19	41B	A2TP5	37F	A3TP4	6C	2A2A1C7	18B
Q7	50G	A1R20	41B	A2TP6	41F				
Q8	50H	A1R21	41B			A3VR1	11C	2A2A1J1	3A-C, 14E, 14H, 22E, 19B
		A1R22	42D			A3VR2	7B		
R1	14C	A1R23	35B	A3C1	7D	A3VR3	11F	2A2A1J2	28B, 29B, 30B, 31B, 30H, 31H, 51C-H, 3D-G, 6A, 14C-I, 22E, 17B
R2	23F	A1R24	35C	A3C2	9F	A3VR4	8D		
R7	36C	A1R25	35D	A3C5	9F	A3VR5	7F		
R8	36G	A1R26	37B	A3C6	11C	A3VR6	7G		
R9	36C	A1R27	38D	A3C7	11F				
				A3C8	10F	A4C3	19H		
S1	27H, 28H, 32D, 32F, 33B, 33H, 44E, 23B	A1TP1	41B	A3C9	10G	A4C4	18F		
		A1TP2	37B	A3C10	8D	A4C5	20F		
		A1TP3	35B			A4C6	18D		
S2	23F	A1TP4	35D	A3CR1	6B	A4C7	28F		
S3	27G, 30E, 48E, 4H	A1TP5	38D	A3CR2	6D	A4C8	17F		
		A1TP6	41D	A3CR3	6D	A4C9	18H		
				A3CR4	10F				
S4	14F			A3CR5	6C	A4CR2	16I		
S5	45E	A2C2	39H	A3CR6	7C	A4CR3	18G		
S6	46F	A2C3	39F	A3CR7	7C	A4CR4	17F		
S7	4B, 4C	A2C4	35G	A3CR8	6C	A4CR5	19G		
S8	3C	A2C5	35G	A3CR12	7D	A4CR6	17E		
S9	15H	A2C6	35G	A3CR13	6G	A4CR7	18F		
S10	21E			A3CR14	6H	A4CR8	20F		
S11	3B			A3CR15	9G	A4CR9	19E		
		A2CR1	39G	A3CR16	9G	A4CR10	18D		
T1	34B, 34H, 5B, 5C, 13C	A2CR2	36I			A4CR11	28F		
		A2CR3	40F			A4CR12	20G		
		A2CR4	40G	A3Q1	11F	A4CR13	28F		
TB1	5A	A2CR5	40F	A3Q2	8F	A4CR16	16E		
		A2CR6	38H	A3Q3	10D	A4CR17	20E		
A1C2	39B	A2CR7	38F	A3Q4	8F				
A1C3	38D	A2CR8	38G	A3Q5	9E	A4Q1	17H		
A1C4	35C	A2CR9	38F	A3Q6	8G	A4Q2	19H		

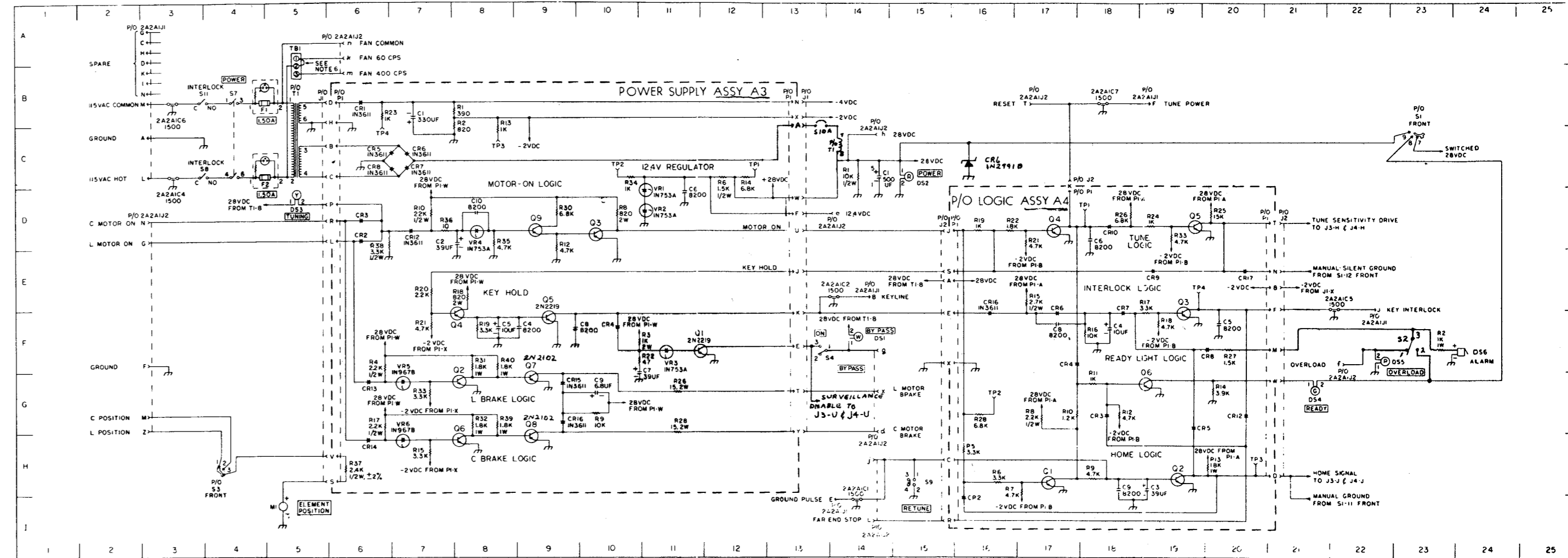
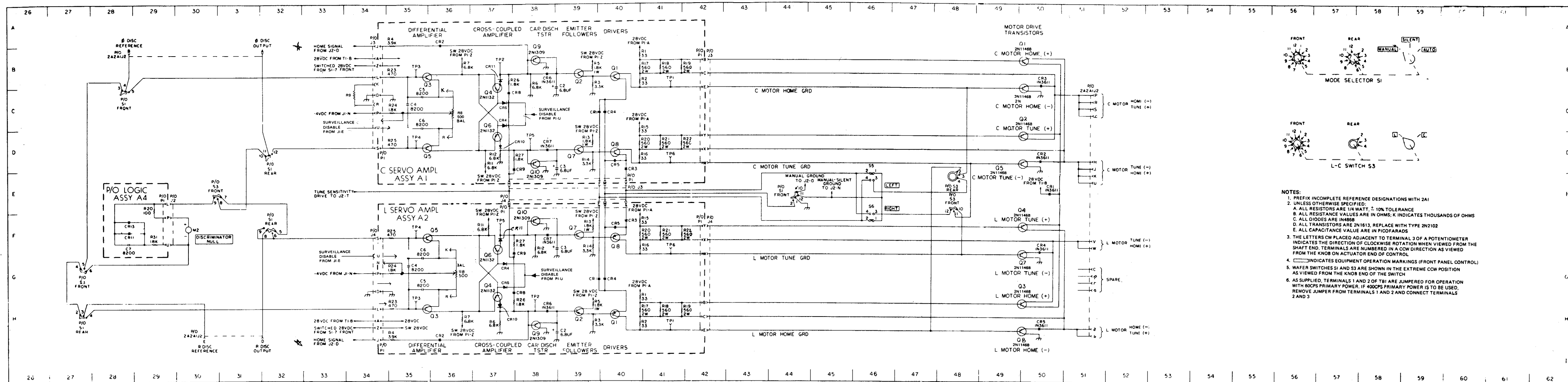

Figure 5-16. Antenna Coupler Control C-3698/URA-38, Schematic Diagram (Sheet 1 of 2)



- NOTES:
1. PREFIX INCOMPLETE REFERENCE DESIGNATIONS WITH 2A1
  2. UNLESS OTHERWISE SPECIFIED:
    - A. ALL RESISTORS ARE 1/4 WATT, ± 10% TOLERANCE
    - B. ALL RESISTANCE VALUES ARE IN OHMS; K INDICATES THOUSANDS OF OHMS
    - C. ALL DIODES ARE IN 4888
    - D. ALL TRANSISTORS ARE 2N1513. REPLACE WITH TYPE 2N2102
    - E. ALL CAPACITANCE VALUE ARE IN PICOFARADS
  3. THE LETTERS CW PLACED ADJACENT TO TERMINAL 3 OF A POTENTIOMETER INDICATES THE DIRECTION OF CLOCKWISE ROTATION WHEN VIEWED FROM THE SHAFT END. TERMINALS ARE NUMBERED IN A CCW DIRECTION AS VIEWED FROM THE KNOB OR ACTUATOR END OF CONTROL
  4. □ INDICATES EQUIPMENT OPERATION MARKINGS (FRONT PANEL CONTROL)
  5. WAFER SWITCHES S1 AND S3 ARE SHOWN IN THE EXTREME CCW POSITION AS VIEWED FROM THE KNOB END OF THE SWITCH
  6. AS SUPPLIED, TERMINALS 1 AND 2 OF T81 ARE JUMPED FOR OPERATION WITH 800PS PRIMARY POWER. IF 400PS PRIMARY POWER IS TO BE USED, REMOVE JUMPER FROM TERMINALS 1 AND 2 AND CONNECT TERMINALS 2 AND 3

Figure 5-16. Antenna Coupler Control C-3698/URA-38, Schematic Diagram (Sheet 2 of 2)

SECTION 6  
PARTS LIST

6-1. REFERENCE DESIGNATIONS.

6-2. The unit numbering method of assigning reference designations has been used to identify units, assemblies, subassemblies, and parts. This method has been expanded as much as necessary to adequately cover the various degrees of subdivision of the equipment. Examples of this unit numbering method and typical expansions of the same are illustrated by the following:

Example 1:

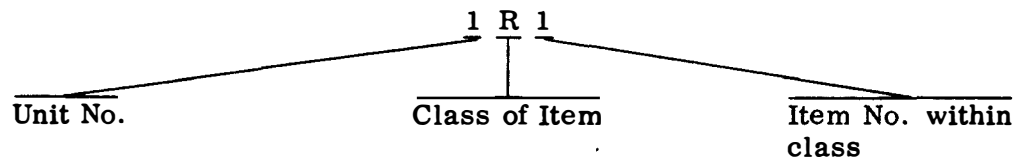

Read as: First (1) resistor (R) of first unit (1).

Example 2:

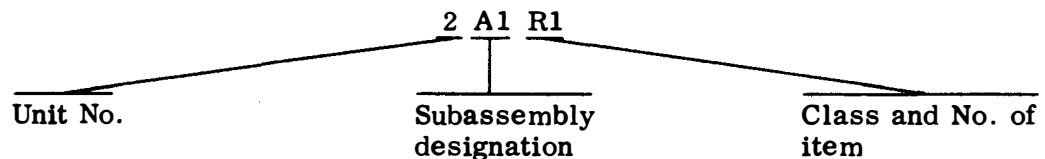

Read as: First (1) resistor (R) of first (1) subassembly (A) of second (2) unit.

Example 3:



Read as: First (1) resistor (R) of second (2) subassembly (A) of first (1) subassembly (A) of second (2) unit.

6-3. REFERENCE DESIGNATION PREFIX.

6-4. Partial reference designations are used on the equipment and illustrations. The partial reference designations consist of the class letter(s) and the identifying item number. The complete reference designations may be obtained by placing the proper prefix before the partial reference designations. Prefixes are provided on illustrations following the notation "REF DESIG PREFIX".

6-5. LIST OF UNITS.

6-6. Table 6-1 is a listing of the units comprising the equipment. The units are listed by unit numbers in numerical order. Thus when the complete reference designation of a part is known, this table will furnish the identification of the unit in which the part is located, since the first number of a complete reference designation identifies the unit. Table 6-1 also provides the following information for each unit listed: (1) quantity per equipment, (2) official name, (3) designation, (4) colloquial name, and (5) location of the first page of its parts listing in table 6-2.

6-7. MAINTENANCE PARTS LIST.

6-8. Table 6-2 lists all units and their maintenance parts. The units are listed in numerical sequence. Maintenance parts for each unit are listed alphabetically-numerically by class of part following the unit designation. Thus the parts for each unit are grouped together. Table 6-2 provides the following information: (1) the complete reference designation of each unit, assembly, subassembly, or part, (2) reference to explanatory notes in paragraph 6-6, (3) noun name and brief description, and (4) identification of the illustration which pictorially locates the part.

6-9. Printed circuit boards, assembly boards, modules, etc., are listed first as individual items in the maintenance parts list. In addition, at the completion of a parts listing for each unit, the individual circuit board, assembly board, module, etc., is then broken down by components into separate parts listings. When there is a redundancy of such electronic assemblies in subsequent units, reference is made to the parts breakdown previously listed.

6-10. LIST OF MANUFACTURERS.

6-11. Table 6-3 lists the manufacturers of the parts used in the equipment. The table includes the manufacturer's code used in table 6-2 to identify the manufacturers.

TABLE 6-1. LIST OF UNITS

UNIT NO.	QTY	NAME OF UNIT	DESCRIPTION	COLLOQUIAL NAME	PAGE
1	1	Antenna Coupler	CU-938/URA-38	Antenna Coupler	6-3
2	1	Antenna Coupler Control	C-3698/URA-38	Coupler Control	6-7

NOTE: The parts list column headed "NOTE " designates the applicable Field Change (FC-#) which modified the part.

TABLE 6-2. MAINTENANCE PARTS LIST

REF	DESIG	NOTE	NAME AND DESCRIPTION	FIG.
			COUPLER GROUP, ANTENNA: AN/URA-38; c/o Antenna Coupler Control and Antenna Coupler. Mfr 14304, P/N 392-0000	1-1
1			COUPLER, ANTENNA: Inductive-Capacitive Coupling; 2-0 to 30.0 MC Range; 115 VAC 48 to 63 or 350 to 450 CPS. Mfr. <del>14304</del> , P/N <del>392-1000</del> <i>50097 392A1000 50097 392A1204</i>	5-3
1A1			CASE ASSEMBLY: MFR. <del>14304</del> - Bottom P/N <del>0902-1204</del> Top Cover P/N <del>8949-1100</del> <i>392R 1305</i>	5-3
1A1E1		FC 4	INSULATOR, ANTENNA: Beryllium Oxide, MFR 05327 P/N A-7073. Return defective insulator to NAVSECNORDIV, 6621E, Norfolk, VA 23511	5-3
1A1J1			CONNECTOR, RECEPTACLE: 37 Pin Mfr. 12143, P/N 10-74128-21P	5-3
1A1J2			CONNECTOR, COAXIAL: MIL TYPE UG-30 E/U	5-3
1A1M1			GAGE, PRESSURE: 0-30 PSI, 1LB Graduations; 1½" nominal diameter; stem 1/8" IPS. AW-1½-9-0 Mfr. 61349	5-3
1A1MP1		FC 1	GASKET, COVER: Sheller Globe, Inc., Norfolk, Va. P/N 1257230	5-3
1A1MP2			Not used	
1A1MP3		FC 5	VALVE, RELIEF: Adjustable, set for 10 psi, MFR 50097, P/N M58500-001	5-3
1A1MP4			VALVE, CHARGING: brass, nickel plated Mfr. 91816 Part No. 1468-1 with 7613T Valve Core, 6300C CAP.	5-3
1A1MP5		FC 1	PLATE, ANTI-TURN: NAVSHIPS DWG. 450-4301357	5-4
1A1MP6		FC 4	GASKET, CORK: MFR 05327 P/N MF7073-14	5-3
1A2			CHASSIS ASSEMBLY: Mfr. <u>14303</u> , P/N None.	5-4
1A2B1			FAN, DUAL FREQUENCY: 115 Volts, 60 or 400 Cycles Mfr. 14304, P/N 392-1404	5-4

TABLE 6-2. MAINTENANCE PARTS LIST (Con't)

REF DESIG	NOTE	NAME AND DESCRIPTION	FIG.
1A2C1		CAPACITOR, VARIABLE VACUUM: 10-500MF 15 KV 42 Amps RMS ITT Jennings Part No. UCSF500-15D1658	5-4
1A2C2		CAPACITOR, FIXED PAPER: 3UF±20% 400 VDC, non-magnetic metal case. Mfr. 00656, P/N P30ZN3	5-4
1A2C3		CAPACITOR, FIXED PAPER: 3 UF±20% 400 VDC, non-magnetic metal case. Mfr. 00656, P/N P30ZN3	5-4
1A2CR1		DIODE: MIL Type 1N3611M	5-4
1A2CR2		DIODE: MIL Type 1N3611M	5-4
1A2K1	FC 5	RELAY, DPDT: MIL-R-5757/10-035	5-7
1A2K2	FC 3	RELAY, VACUUM CERAMIC: ITT Jennings RF-1E	5-4
1A2K3	FC 3	RELAY, VACUUM CERAMIC: ITT Jennings RF-1E	5-4
1A2L1		COIL, VARIABLE: R.F. Coil Assembly NAVSHIPS DWG. 450-4302-456	5-4
1A2MP1		BEARING, BALL: Flanged-shielded ball bearing with extended inner ring. Mfr. 83086, P/N SFR 1883 MEE	5-7
1A2MP2		BEARING, BALL: Flanged-shielded ball bearing with extended inner ring. Mfr. 83086, P/N SFR 1883M Mee	5-7
1A2MP3	FC 3	ROTOR ASSEMBLY: Part of coil assembly 1A2L1 NAVSHIPS DWG. 450-4302347	5-7
1A2MP4	FC 3	CAM ACTUATOR: NAVSHIPS DWG. 450-SK2100012	5-4
1A2MP5	FC 3	END STOP: Part of coil assembly 1A2L1, NAVSHIPS DWG. 450-SK2100013	5-7
1A2MP6	FC 3	RELAY BRACKET: NAVSHIPS DWG. 450-SK2100017	5-7
1A2R1		Not used	
1A2R2	FC 3	RESISTOR, Fixed composition: 150 ohm, 1 watt MIL- TYPE RCR32GF151J	5-7
1A2R3	FC 5	RESISTOR, FIXED COMPOSITION: 150 OHM, 1 Watt MIL-Type RCR32GF151J	5-4
1A2S1		SWITCH, THERMAL: Closing temperature +265±5°F Opening temperature +240±5° open-close differential 25° max. Mfr. 14304, P/N 570-0001	5-7

TABLE 6-2. MAINTENANCE PARTS LIST (Con't)

PLF DESIG	NOTE	NAME AND DESCRIPTION	FIG.
1A2S2	FC 3	SWITCH, SENSITIVE: MIL-TYPE MS25085-1	5-4
1A2S3	FC 5	SWITCH, THERMAL: Closing temperature 120°F, Opening temperature 111°F. MIL-S-24236/1C-0695	5-7
1A2S4	FC 5	SWITCH, PRESSURE: MFR. 50097, P/N C51000-001	5-4
1A2T1		TRANSFORMER, TOROID: MFR 14304, P/N 392-1320	5-4
1A2A1		CAPACITOR DRIVE ASSEMBLY: Mfr. 14304, P/N 392-2300	5-6
1A2A1B1		MOTOR, DC: 15MHP, 13,000 RPM, 27 VDC, Mfr. 14304, P/N 392-1602	5-6
1A2A1CR1		DIODE: MIL Type 1N3611	5-6
1A2A1CR2		DIODE: MIL Type 1N3611	5-6
1A2A1CR3		DIODE: MIL Type 1N3611	5-6
1A2A1CR4		DIODE: MIL Type 1N3611	5-6
1A2A1CR5		DIODE: MIL Type 1N3611	5-6
1A2A1CR6		DIODE: MIL Type 1N3611	5-6
1A2A1CR7		DIODE: MIL Type 1N3611	5-6
1A2A1CR8		DIODE: MIL Type 1N3611	5-6
1A2A1CR9		DIODE: MIL Type 1N3611	5-6
1A2A1CR10		DIODE: MIL Type 1N3611	5-6
1A2A1CR11		Not Used	
1A2A1CR12		DIODE: MIL Type 1N3611	5-6
1A2A1CR13		DIODE: MIL Type 1N3611	5-6
1A2A1MP1		GEAR TRAIN ASSY: Mfr. 14304, P/N 392-2303	5-6
1A2A1MP2		PRIMARY GEAR ASSY: Mfr. 14304, P/N 392-1617	5-6
1A2A1MP3		SECONDARY GEAR ASSY: Mfr. 14304, P/N 392-1616	5-6
1A2A1MP4		COUPLING, JACKSON BROS. Ltd. P/N 4693 MOD (0.188/0.250)	5-4
1A2A1R1		RESISTOR, VARIABLE COMPOSITION: 5000 Ohms Mfr. 14304, P/N 392-1607	5-4
1A2A1S1		SWITCH, LIMIT: Micro-switch, MIL Type MS25343-1	5-6
1A2A1S2		SWITCH, LIMIT: Micro-switch, MIL Type MS25343-1	5-6
1A2A2		DISCRIMINATOR ASSEMBLY: Mfr. 14304, P/N 392-1500	5-5



TABLE 6-2. MAINTENANCE PARTS LIST (Con't)

REF DESIG	NOTE	NAME AND DESCRIPTION	FIG.
1A2A2C1		CAPACITOR, FIXED GLASS: 50PF, 500 VDC MIL Type CY13C51RC	5-5
1A2A2C2		CAPACITOR, FIX CERAMIC: 8200 PF 500 VDC MIL TYPE CK62AW822M	5-5
1A2A2C3		CAPACITOR, FIXED CERAMIC: 8200 PF 500 VDC MIL Type CK62AW822M	5-5
1A2A2C4		CAPACITOR, FIXED CERAMIC: 8200 PF, 500 VDC MIL Type CK62AW822M	5-5
1A2A2C5		CAPACITOR, FIXED CERAMIC: 8200 PF, 500 VDC MIL Type CK62AW822M	5-5
1A2A2C6		CAPACITOR, VARIABLE GLASS: MIL Type PC41J8R5	5-5
1A2A2C7		CAPACITOR, FIXED MICA: 330 PF, 500 VDC MIL Type CM05D331J03	5-5
1A2A2C8		CAPACITOR, FIXED CERAMIC: 8200 PF, 500 VDC MIL Type CK62AW822M	5-5
1A2A2C9		CAPACITOR, FIXED CERAMIC: 8200 PF, 500 VDC MIL Type CK62AW822M	5-5
1A2A2C10		CAPACITOR, FIXED CERAMIC: 8200 PF, 500 VDC MIL Type CK62AW822M	5-5
1A2A2C11		CAPACITOR, FIXED CERAMIC: 8200 PF, 500 VDC MIL Type CK62AW822M	5-5
1A2A2CR1		DIODE: MIL Type 1N914 (Replace with 1N4148)	5-5
1A2A2CR2		DIODE: MIL Type 1N914 (Replace with 1N4148)	5-5
1A2A2CR3		Not Used	
1A2A2CR4		Not Used	
1A2A2CR5		DIODE: MIL Type 1N914 (Replace with 1N4148)	5-5
1A2A2CR6		DIODE: MIL Type 1N914 (Replace with 1N4148)	5-5
1A2A2E1		TERMINATION, COAXIAL: MIL Type MX-1530A/U	5-5
1A2A2P1		CONNECTOR, COAXIAL: MIL Type UG-536B/U	5-5
1A2A2L1		COIL, FIXED RF: MIL Type LT4K029	5-5
1A2A2L2		Not Used	

TABLE 6-2. MAINTENANCE PARTS LIST (Con't)

REF	DESIG	NOTE	NAME AND DESCRIPTION	FIG.
1A2A2L3			COIL, FIXED RF: Mfr. 143-4, P/N L10-0002-054	5-5
1A2A2R1			RESISTOR, FIXED FILM: 390 Ohms, 1 Watt MIL Type RL32S391G	5-5
1A2A3R2			RESISTOR, FIXED FILM: 390 Ohms, 1 Watt MIL Type RL32S391G	5-5
1A2A2R3			RESISTOR, FIXED FILM: 220 Ohms, 2 Watts MIL Type RL42S221J	5-5
1A2A2R4			RESISTOR, FIXED COMPOSITION: 3900 Ohms, $\frac{1}{2}$ Watt MIL Type RC20GF392K	5-5
1A2A2R5			RESISTOR, FIXED COMPOSITION: 3900 Ohms, $\frac{1}{2}$ Watt MIL Type RC20GF392K	5-5
1A2A2R6			RESISTOR, VARIABLE WIREWOUND: 2000 Ohms MIL Type RT11C2P202	5-5
1A2A2R7			RESISTOR, FIXED FILM: 100 Ohms, 2 Watts MIL Type RL42S101J	5-5
1A2A2R8			Not Used.	
1A2A2R9			RESISTOR, FIXED COMPOSITION: 100 Ohms, $\frac{1}{2}$ Watt MIL Type RC20GF101K	5-5
1A2A2R10			RESISTOR, FIXED FILM: 220 Ohms, 2 Watts MIL Type R142S221J	5-5
1A2A2R11			RESISTOR, FIXED COMPOSITION: 1500 Ohms, $\frac{1}{2}$ Watt MIL Type RC20GF152K	5-5
1A2A2R12			RESISTOR, FIXED COMPOSITION: 1500 Ohms, $\frac{1}{2}$ Watt MIL Type RC20GF152K	5-5
1A2A2R13			RESISTOR, FIXED COMPOSITION: 3300 Ohms, $\frac{1}{2}$ Watt MIL Type RC20GF332K	5-5
1A2A2R14			RESISTOR, FIXED COMPOSITION: 1500 Ohms, $\frac{1}{2}$ Watt MIL Type RC20GF152K	5-5
1A2A2R15			RESISTOR, FIXED COMPOSITION: 1500 Ohms, $\frac{1}{2}$ Watt MIL Type RC20GF152K	5-5
1A2A2R16			RESISTOR, FIXED COMPOSITION: 4700 Ohms, $\frac{1}{2}$ Watt MIL Type RL20S472G	5-5
1A2A2R17			RESISTOR, FIXED COMPOSITION: 4700 Ohms, $\frac{1}{2}$ Watt MIL Type RL20S472G	5-5

TABLE 6-2. MAINTENANCE PARTS LIST (Con't)

REF DESIG	NOTE	NAME AND DESCRIPTION	FIG.
1A2A2R18		RESISTOR, FIXED COMPOSITION: 3300 Ohms, $\frac{1}{2}$ Watt MIL Type RC20GF332K	5-5
1A2A2R19		RESISTOR, FIXED COMPOSITION: 820 Ohms, $\frac{1}{2}$ Watt MIL Type RC20GF821K	5-5
1A2A2R20		RESISTOR, FIXED COMPOSITION: 12K Ohms, $\frac{1}{4}$ Watt MIL Type RC07GF123K	5-5
1A2A2T1		TRANSFORMER, TOROID: Mfr 14304, P/N T10-0002-000	5-5
1A2A2T2		TRANSFORMER, TOROID: Mfr. 14304, P/N T10-0001-000	5-5
1A2A3		COIL DRIVE ASSEMBLY: Mfr. 14304, P/N 392-1600	5-6
1A2A3B1		MOTOR, D.C.: 15 MHP 13,000 RPM, 27 VDC Mfr. 14304, P/N 392-1602	5-6
1A2A3MP1		GEAR TRAIN ASSEMBLY: Mfr. 14304, P/N 392-1603	5-6
1A2A3MP2		PRIMARY GEAR ASSEMBLY: Mfr. 14304, P/N 392-1617	5-6
1A2A3MP3		SECONDARY GEAR ASSEMBLY: Mfr. 14304, P/N 392-1616	5-6
1A2A3MP4		COUPLING, JACKSON BROS. Ltd. P/N 4693 MOD (Q.188/0.250)	5-6
1A2A3R1		RESISTOR, VARIABLE COMPOSITION: 5000 Ohms Mfr. 14304, P/N 392-1607	5-4
1A2A3S1		SWITCH LIMIT: Micro switch, MIL Type MS25343-1	5-6
1A2A3S2		SWITCH LIMIT: Micro switch, MIL Type MS25343-1	5-6
1A2A4	FC 1	PROTECTOR ASSEMBLY: Modified	5-4
1A2A4C1	FC 1	Not Used	
2		ANTENNA COUPLER CONTROL: C-3698/URA-38 Mfr. 14304, P/N 392-6000	5-8
2A1		CHASSIS-PANEL ASSEMBLY: Mfr. 14304, P/N 392-6100	5-8
2A1C1		CAPACITOR, FIXED ELECTROLYTIC: 500MF MIL Type CE51C501G	5-8
2A1C2	FC 2	CAPACITOR, FIXED ELECTROLYTIC: Tantalum, non-polarized, 9.5 MF, 60 V, MIL Type TE 9.5-60C1N1	5-8
2A1C3	FC 2	CAPACITOR, FIXED ELECTROLYTIC: Tantalum, non-polarized, 9.5 MF, 60 V, MIL Type TE 9.5-60C1N1	5-8

TABLE 6-2. MAINTENANCE PARTS LIST (Con't)

REF	DESIG	NOTE	NAME AND DESCRIPTION	FIG.
2A1CR1			DIODE: MIL Type 1N3611	5-8
2A1CR2			DIODE: MIL Type 1N3611	5-8
2A1CR3			DIODE: MIL Type 1N3611	5-8
2A1CR4			DIODE: MIL Type 1N3611	5-8
2A1CR5			DIODE: MIL Type 1N3611	5-8
2A1CR6		FC 2	DIODE: MIL Type 1N2991B	5-8
2A1DS5			LAMP, INCANDESCENT: MIL Type MS25237-327T (Replace with MS18209-387)	5-8
2A1F1			FUSE, CARTRIDGE: MIL Type FO2A1-1.5A	5-8
2A1F2			FUSE CARTRIDGE: MIL Type FO2A1-1.5A	5-8
2A1J1			CONNECTOR, RECEPTACLE: MIL Type M21097-4	5-8
2A1J2			CONNECTOR, RECEPTACLE: MIL Type M21097-4	5-8
2A1J3			CONNECTOR, RECEPTACLE: MIL Type M21097-4	5-8
2A1J4			CONNECTOR, RECEPTACLE: MIL Type M21097-4	5-8
2A1M1			METER, PANEL: Mfr. 14304, P/N 392-6106	5-8
2A1M2			METER PANEL: Mfr. 14304, P/N 392-6107	5-8
2A1Q1			TRANSISTOR: MIL Type 2N1146B	5-8
2A1Q2			TRANSISTOR: MIL Type 2N1146B	5-8
2A1Q3			TRANSISTOR: MIL Type 2N1146B	5-8
2A1Q4			TRANSISTOR: MIL Type 2N1146B	5-8
2A1Q5			TRANSISTOR: MIL Type 2N1146B	5-8
2A1Q6			TRANSISTOR: MIL Type 2N1146B	5-8
2A1Q7			TRANSISTOR: MIL Type 2N1146B	5-8
2AQ8			TRANSISTOR: MIL Type 2N1146B	5-8
2A1R1			RESISTOR, FIXED COMPOSITION: 10K Ohms $\pm$ 10% $\frac{1}{2}$ Watt MIL Type RC20GF103K	5-8
2A1R2			RESISTOR, FIXED COMPOSITION: 1K Ohms $\pm$ 10% 1 Watt MIL Type RC32GF102K	5-8

TABLE 6-2. MAINTENANCE PARTS LIST (Con't)

REF	DESIG	NOTE	NAME AND DESCRIPTION	FIG.
2A1R3			Not Used.	
2A1R4			Not Used.	
2A1R5			Not Used.	
2A1R6			Not Used.	
2A1R7		FC 3	Not Used	
2A1R8		FC 3	Not Used.	
2A1R9			RESISTOR, FIXED COMPOSITION: 120 Ohms $\pm$ 10%, $\frac{1}{4}$ Watt MIL Type RC07GF121K	5-8
2A1S1			SWITCH, ROTARY: Mfr. 14304, P/N 392-6117	5-8
2A1S2		FC 2	SWITCH, TOGGLE: SPDT, MIL Type MS35058-23	5-8
2A1S3			SWITCH, ROTARY: Mfr. 14304, P/N 392-6118	5-8
2A1S4		FC 5	Not Used.	
2A1S5			SWITCH, PB: MIL Type MS25089-3C	5-8
2A1S6			SWITCH, PB: MIL Type MS25089-3C	5-8
2A1S7			SWITCH, TOGGLE: DPST, MIL Type MS35059-22	5-8
2A1S8			SWITCH, INTERLOCK: MIL Type MS16106-4	5-8
2A1S9			SWITCH, PB: MIL Type MS25089-1C	5-8
2A1S10		FC 2	SWITCH CIRCUIT BREAKER: 1.5A KLIXON MIL Type MS26574-1 $\frac{1}{2}$ .	5-8
2A1T1			TRANSFORMER, POWER: Mfr. 14304, P/N 392-6135	5-8
2A1TB1			TERMINAL BOARD: Mfr. 75382, P/N 37TB3	5-8
2A1XC1			SOCKET, OCTAL: MIL Type TS101P01	5-8
22A1XDS1			LAMPHOLDER: MIL Type LH 73LC12WT	5-8
2A1XDS2			LAMPHOLDER: MIL Type LH 73LC12RT	5-8
2A1XDS3			LAMPHOLDER: MIL Type LH 73LC12YT	5-8
2A1XDS4			LAMPHOLDER: MIL Type LH 73LC12GT	5-8
2A1XDS5			LAMPHOLDER: MIL Type LH 73LC12RT	5-8

TABLE 6-2. MAINTENANCE PARTS LIST (Con't)

REF DESIG	NOTE	NAME AND DESCRIPTION	FIG.
2A1XF1		FUSEHOLDER: MIL Type FHL17G	5-8
2A1XF2		FUSEHOLDER: MIL Type FHL17G	5-8
2A1A1		C SERVO AMPLIFIER PCB ASSEMBLY: ✓ Mfr. 14304, P/N 392-6400	5-8
2A1A1C1		Not Used.	
2A1A1C2		CAPACITOR, FIXED ELECTROLYTIC: 6.8 MF 6 VDC MIL Type CS13BB685K	5-9
2A1A1C3		CAPACITOR, FIXED ELECTROLYTIC: 6.8 MF 6 VDC MIL Type CS13BB685K	5-9
2A1A1C4		CAPACITOR, FIXED <sup>CERAMIC</sup> ELECTROLYTIC: 8200PF 500 VDC MIL Type <del>CK62AW822M</del> CM62AW822	5-9
2A1A1C5		CAPACITOR, FIXED <sup>CERAMIC</sup> ELECTROLYTIC: 8200PF 500 VDC MIL Type <del>CK62AW822M</del> CM62AW822	5-9
2A1A1C6		CAPACITOR, FIXED <sup>CERAMIC</sup> ELECTROLYTIC: 8200PF 500 VDC MIL Type <del>CK62AW822M</del> CM62AW822	5-9
2A1A1CR1		DIODE: MIL Type 1N486B	5-9
2A1A1CR2		DIODE: MIL Type 1N486B	5-9
2A1A1CR3		DIODE: MIL Type 1N486B	5-9
2A1A1CR4		DIODE: MIL Type 1N486B	5-9
2A1A1CR5		DIODE: MIL Type 1N486B	5-9
2A1A1CR6		DIODE: MIL Type <del>1N914</del> 1N3611	5-9
2A1A1CR7		DIODE: MIL Type <del>1N914</del> 1N3611	5-9
2A1A1CR8		DIODE: MIL Type 1N486B	5-9
2A1A1CR9		DIODE: MIL Type 1N486B	5-9
2A1A1CR10	FC 3	DIODE: MIL Type 1N486B	5-9
2A1A1CR11	FC 3	DIODE: MIL Type 1N486B	5-9
2A1A1CR12	<del>FC 3</del>	<del>DIODE: MIL Type 1N486B</del> Not Used	5-9
2A1A1CR13	<del>FC 3</del>	<del>DIODE: MIL Type 1N486B</del> Not Used	5-9
2A1A1MP1		SERVO AMPLIFIER PCB: Mfr. 14304, P/N 392-6401	5-9

TABLE 6-2. MAINTENANCE PARTS LIST (Con't)

REF DESIG	NOTE	NAME AND DESCRIPTION	FIG.
2A1A1Q1		TRANSISTOR: MIL Type 2N1613 (Replace with 2N2102)	5-9
2A1A1Q2		TRANSISTOR: MIL Type 2N1613 (Replace with 2N2102)	5-9
2A1A1Q3		TRANSISTOR: MIL Type 2N1613 (Replace with 2N2102)	5-9
2A1A1Q4		TRANSISTOR: MIL Type 2N1132	5-9
2A1A1Q5		TRANSISTOR: MIL Type 2N1613 (Replace with 2N2102)	5-9
2A1A1Q6		TRANSISTOR: MIL Type 2N1132	5-9
2A1A1Q7		TRANSISTOR: MIL Type 2N1613 (Replace with 2N2102)	5-9
2A1A1Q8		TRANSISTOR: MIL Type 2N1613 (Replace with 2N2102)	5-9
2A1A1Q9		TRANSISTOR: MIL Type 2N1309	5-9
2A1A1Q10		TRANSISTOR: MIL Type 2N1309	5-9
2A1A1R1		RESISTOR, FIXED COMPOSITION: 33 Ohms, $\frac{1}{4}$ Watt $\pm$ 10% MIL Type RC07GF330K	5-9
2A1A1R2		RESISTOR, FIXED COMPOSITION: 33 Ohms, $\frac{1}{4}$ Watt $\pm$ 10% MIL Type RC07GF330K	5-9
2A1A1R3		RESISTOR, FIXED COMPOSITION: 3300 Ohms $\pm$ 10% $\frac{1}{4}$ Watt MIL Type RC07GF332K	5-9
2A1A1R4		RESISTOR, FIXED COMPOSITION: 3900 Ohms $\pm$ 10% $\frac{1}{4}$ Watt MIL Type RC07GF392K	5-9
2A1A1R5		RESISTOR, FIXED COMPOSITION: 1800 Ohms $\pm$ 10% 1 Watt MIL Type RC32GF182K	5-9
2A1A1R6		RESISTOR, FIXED COMPOSITION: 6800 Ohms $\pm$ 10% $\frac{1}{4}$ Watt MIL Type RC07GF682K	5-9
2A1A1R7		RESISTOR, FIXED COMPOSITION: 1800 Ohms $\pm$ 10% $\frac{1}{4}$ Watt MIL Type RC07GF682K	5-9
2A1A1R8	FC-3	RESISTOR, VARIABLE: Plastic case 500 Ohms MIL Type RT22C2L501	5-7
2A1A1R9		Not Used.	
2A1A1R10		Not Used.	
2A1A1R11		RESISTOR, FIXED COMPOSITION: 6800 Ohms $\pm$ 10% $\frac{1}{4}$ Watt MIL Type RC07GF682K	5-9

TABLE 6-2. MAINTENANCE PARTS LIST (Con't)

REF DESIG	NOTE	NAME AND DESCRIPTION	FIG.
2A1A1R12		RESISTOR, FIXED COMPOSITION: 6800 Ohms ± 10% ½ Watt MIL Type RC07GF682K	5-9
2A1A1R13		RESISTOR, FIXED COMPOSITION: 1800 Ohms ± 10% 1 Watt MIL Type RC32GF182K	5-9
2A1A1R14		RESISTOR, FIXED COMPOSITION: 3300 Ohms ± 10% ½ Watt MIL Type RC07GF332K	5-9
2A1A1R15		RESISTOR, FIXED COMPOSITION: 33 Ohms ± 10% ½ Watt MIL Type RC07GF330K	5-9
2A1A1R16		RESISTOR, FIXED COMPOSITION: 33 Ohms ± 10% ½ Watt MIL Type RC07GF330K	5-9
2A1A1R17		RESISTOR, FIXED COMPOSITION: 560 Ohms, ± 10% 2 Watt MIL Type RC42GF561K	5-9
2A1A1R18		RESISTOR, FIXED COMPOSITION: 560 Ohms ± 10% 2 Watt MIL Type RC42GF561K	5-9
2A1A1R19		RESISTOR, FIXED COMPOSITION: 560 Ohms ± 10% 2 Watt MIL Type RC42GF561K	5-9
2A1A1R20		RESISTOR, FIXED COMPOSITION: 560 Ohms ± 10% 2 Watt MIL Type RC42GF561K	5-9
2A1A1R21		RESISTOR, FIXED COMPOSITION: 560 Ohms ± 10% 2 Watts MIL Type RC42GF561K	5-9
2A1A1R22		RESISTOR, FIXED COMPOSITION: 560 Ohms ± 10% 2 Watts MIL Type RC42GF561K	5-9
2A1A1R23		RESISTOR, FIXED COMPOSITION: 470 Ohms ± 10% ½ Watt MIL Type RC07GF471K	5-9
2A1A1R24		RESISTOR, FIXED COMPOSITION: 1800 Ohms ± 10% ½ Watt MIL Type RC07GF182K	5-9
2A1A1R25		RESISTOR, FIXED COMPOSITION: <sup>470</sup> <del>1800</del> Ohms ± 10% ½ Watt MIL Type <del>RC07GF182K</del> RC7GF471K	5-9
2A1A1R26		RESISTOR, FIXED COMPOSITION: 1800 Ohms ± 10% ½ Watt MIL Type RC07GF182K	5-9
2A1A1R27		RESISTOR, FIXED COMPOSITION: <sup>1800</sup> <del>2000</del> Ohms ± 10% ½ Watt MIL Type <del>RC07GF302K</del> RC07GF182K	5-9
2A1A1TP1		JACK, TEST: Mfr. 7497Q, P/N 105-75 <sup>8</sup> <del>7</del>	5-9
2A1A1TP2		JACK, TEST: Mfr. 74970, P/N 105-75 <sup>2</sup> <del>7</del>	5-9



TABLE 6-2. MAINTENANCE PARTS LIST (Con't)

REF DESIG	NOTE	NAME AND DESCRIPTION	FIG.
2A1A1TP3		JACK, TEST: Mfr. 74970, P/N 105-75 <del>7</del> <sup>6</sup>	5-9
2A1A1TP4		JACK, TEST: Mfr. 74970, P/N 105-757	5-9
2A1A1TP5		JACK, TEST: Mfr. 74970, P/N 105-75 <del>7</del> <sup>4</sup>	5-9
2A1A1TP6		JACK, TEST: Mfr. 74970, P/N 105-7 <del>5</del> <sup>60</sup>	5-9
2A1A2		L SERVO AMPLIFIER PCB ASSEMBLY: ✓ Mfr. 14304, P/N 392-6400	5-8
2A1A2C1		Not Used.	
2A1A2C2		CAPACITOR, FIXED ELECTROLYTIC: 6.8 MF ±10%, 6 VDC MIL Type CS13BB68JK	5-9
2A1A2C3		CAPACITOR, FIXED ELECTROLYTIC: 6.8 MF ±10%, 6 VDC MIL Type CS13BB68JK	5-9
2A1A2C4		CAPACITOR, FIXED ELECTROLYTIC: 6.8 MF ±10%, 6 VDC MIL Type CS13BB68JK	5-9
2A1A2C5		CAPACITOR, FIXED ELECTROLYTIC: 6.8 MF ±10%, 6 VDC MIL Type CS13BB68JK	5-9
2A1A2C6		CAPACITOR, FIXED ELECTROLYTIC: 6.8 MF ±10%, 6 VDC MIL Type CS13BB68JK	5-9
2A1A2CR1		DIODE: MIL Type 1N486B	5-9
2A1A2CR2		DIODE: MIL Type 1N486B	5-9
2A1A2CR3		DIODE: MIL Type 1N486B	5-9
2A1A2CR4		DIODE: MIL Type 1N486B	5-9
2A1A2CR5		DIODE: MIL Type 1N486B	5-9
2A1A2CR6		DIODE: MIL Type 1N914	5-9
2A1A2CR7		DIODE: MIL Type 1N914	5-9
2A1A2CR8		DIODE: MIL Type 1N486B	5-9
2A1A2CR9		DIODE: MIL Type 1N486B	5-9
2A1A2MP1		SERVO AMPLIFIER PCB: Mfr. 14304, P/N 392-6401	5-9
2A1A2Q1		TRANSISTOR: MIL Type 2N1613 (Replace with 2N2102)	5-9
2A1A2Q2		TRANSISTOR: MIL Type 2N1613 (Replace with 2N2102)	5-9

TABLE 6-2. MAINTENANCE PARTS LIST (Con't)

REF	DESIGN	NOTE	NAME AND DESCRIPTION	FIG.
2A1A2Q3			TRANSISTOR: MIL Type 2N1613 (Replace with 2N2102)	5-9
2A1A2Q4			TRANSISTOR: MIL Type 2N1132	
2A1A2Q5			TRANSISTOR: MIL Type 2N1613 (Replace with 2N2102)	5-9
2A1A2Q6			TRANSISTOR: MIL Type 2N1132	
2A1A2Q7			TRANSISTOR: MIL Type 2N1613 (Replace with 2N2102)	5-9
2A1A2Q8			TRANSISTOR: MIL Type 2N1613 (Replace with 2N2102)	5-9
2A1A2Q9			TRANSISTOR: MIL Type 2N1309	5-9
2A1A2Q10			TRANSISTOR: MIL Type 2N1309	5-9
2A1A2R1			RESISTOR, FIXED COMPOSITION: 33 Ohms $\pm$ 10%, $\frac{1}{2}$ Watt MIL Type RC07GF330K	5-9
2A1A2R2			RESISTOR, FIXED COMPOSITION: 33 Ohms $\pm$ 10%, $\frac{1}{2}$ Watt MIL Type RC07GF330K	5-9
2A1A2R3			RESISTOR, FIXED COMPOSITION: 3900 Ohms $\pm$ 10%, $\frac{1}{2}$ Watt MIL Type RC07GF392K	5-9
2A1A2R4			RESISTOR, FIXED COMPOSITION: 3900 Ohms $\pm$ 10%, $\frac{1}{2}$ Watt MIL Type RC07GF392K	5-9
2A1A2R5			RESISTOR, FIXED COMPOSITION: 1800 Ohms $\pm$ 10%, 1 Watt MIL Type RC07GF182K	5-9
2A1A2R6			RESISTOR, FIXED COMPOSITION: 6800 Ohms $\pm$ 10%, $\frac{1}{2}$ Watt MIL Type RC07GF682K	5-9
2A1A2R7			RESISTOR, FIXED COMPOSITION: 1800 Ohms $\pm$ 10%, $\frac{1}{2}$ Watt MIL Type RC07GF182K	5-9
2A1A2R8			RESISTOR, VARIABLE: Plastic case 500 Ohms MIL Type RT22C2L501	5-7
2A1A2R9			Not Used.	
2A1A2R10			Not Used.	
2A1A2R11			RESISTOR, FIXED COMPOSITION: 6800 Ohms $\pm$ 10%, $\frac{1}{2}$ Watt MIL Type RC07GF682K	5-9
2A1A2R12			RESISTOR, FIXED COMPOSITION: 6800 Ohms $\pm$ 10%, $\frac{1}{2}$ Watt MIL Type RC07GF682K	5-9
2A1A2R13			RESISTOR, FIXED COMPOSITION: 1800 Ohms $\pm$ 10%, 1 Watt MIL Type RC32GF182K	5-9

TABLE 6-2. MAINTENANCE PARTS LIST (Con't)

REF DESIG	NOTE	NAME AND DESCRIPTION	FIG.
2A1A2R14		RESISTOR, FIXED COMPOSITION: 3300 Ohms $\pm$ 10%, $\frac{1}{4}$ Watt MIL Type RC07GF332K	5-9
2A1A2R15		RESISTOR, FIXED COMPOSITION: 33 Ohms $\pm$ 10%, $\frac{1}{4}$ Watt MIL Type RC07GF330K	5-9
2A1A2R16		RESISTOR, FIXED COMPOSITION: 33 Ohms $\pm$ 10%, $\frac{1}{4}$ Watt MIL Type RC07GF330K	5-9
2A1A2R17		RESISTOR, FIXED COMPOSITION: 560 Ohms $\pm$ 10%, 2 Watt MIL Type RC42GF561K	5-9
2A1A2R18		RESISTOR, FIXED COMPOSITION: 560 Ohms $\pm$ 10%, 2 Watt MIL Type RC42GF561K	5-9
2A1A2R19		RESISTOR, FIXED COMPOSITION: 560 Ohms $\pm$ 10%, 2 Watt MIL Type RC42GF561K	5-9
2A1A2R20		RESISTOR, FIXED COMPOSITION: 560 Ohms $\pm$ 10%, 2 Watt MIL Type RC42GF561K	5-9
2A1A2R21		RESISTOR, FIXED COMPOSITION: 560 Ohms $\pm$ 10%, 2Watt MIL Type RC42GF561K	5-9
2A1A2R22		RESISTOR, FIXED COMPOSITION: 560 Ohms $\pm$ 10%, 2 Watt MIL Type RC42GF561K	5-9
2A1A2R23		RESISTOR, FIXED COMPOSITION: 470 Ohms $\pm$ 10%, $\frac{1}{4}$ Watt MIL Type RC07GF471K	5-9
2A1A2R24		RESISTOR, FIXED COMPOSITION: 1800 Ohms $\pm$ 10%, $\frac{1}{4}$ Watt MIL Type RC07GF182K	5-9
2A1A2R25		RESISTOR, FIXED COMPOSITION: 1800 Ohms $\pm$ 10%, $\frac{1}{4}$ Watt MIL Type RC07GF182K	5-9
2A1A2R26		RESISTOR, FIXED COMPOSITION: 1800 Ohms $\pm$ 10%, $\frac{1}{4}$ Watt MIL Type RC07GF182K	5-9
2A1A2R27		RESISTOR, FIXED COMPOSITION: 3900 Ohms $\pm$ 10%, $\frac{1}{4}$ Watt MIL Type RC07GF392K	5-9
2A1A2TP1		JACK, TEST: Mfr. 74970, P/N 105-757	5-9
2A1A2TP2		JACK, TEST: Mfr. 74970, P/N 105-757	5-9
2A1A2TP3		JACK, TEST: Mfr. 74970, P/N 105-757	5-9
2A1A2TP4		JACK, TEST: Mfr. 74970, P/N 105-757	5-9
2A1A2TP5		JACK, TEST: Mfr. 74970, P/N 105-757	5-9

TABLE 6-2. MAINTENANCE PARTS LIST (Con't)

REF DESIG	NOTE	NAME AND DESCRIPTION	FIG.
2A1A2TP6		JACK, TEST: Mfr. 74970, P/N 105-757	5-9
2A1A3		POWER SUPPLY PCB ASSEMBLY: Mfr. 14304, P/N 392-6600 ✓	5-8
2A1A3C1		CAPACITOR, FIXED ELECTROLYTIC: 330 MF ± 10% 7 VDC MIL Type CS13BB337K	5-10
2A1A3C2		CAPACITOR, FIXED ELECTROLYTIC: 39 MF ± 10% 10 VDC MIL Type CS13BC396K	5-10
2A1A3C3		Not Used.	
2A1A3C4		CAPACITOR, FIXED <del>ELECTROLYTIC</del> <sup>CERAMIC</sup> 8200PF: 39 MF ± 10% 10 VDC MIL Type <del>CS13BC396K</del> CK62AW822M	5-10
2A1A3C5		CAPACITOR, FIXED ELECTROLYTIC: 10 MF ± 10% 25 VDC MIL Type CS13BE106K	5-10
2A1A3C6		CAPACITOR, FIXED <del>ELECTROLYTIC</del> <sup>CERAMIC</sup> : 39 MF ± 10% 10 VDC MIL Type <del>CS13BC396K</del> CK62AW822M	5-10
2A1A3C7		CAPACITOR, FIXED ELECTROLYTIC: 39 MF ± 10% 10 VDC MIL Type CS13BB396K	5-10
2A1A3C8		CAPACITOR, FIXED <del>ELECTROLYTIC</del> <sup>CERAMIC</sup> : 39 MF ± 10% 10 VDC MIL Type <del>CS13BB396K</del> CK62AW822M	5-10
2A1A3C9		CAPACITOR, FIXED ELECTROLYTIC: 6.8 MF ± 10% 30 VDC MIL Type CS13BF685K	5-10
2A1A3C10		CAPACITOR, FIXED <del>ELECTROLYTIC</del> <sup>CERAMIC</sup> : 39 MF ± 10% 10 VDC MIL Type <del>CS13BB396K</del> CK62AW822M	5-10
2A1A3C11		CAPACITOR, FIXED <del>ELECTROLYTIC</del> <sup>"</sup> : 39 MF ± 10% 10 VDC MIL Type <del>CS13BB396K</del> "	5-10
2A1A3C12		CAPACITOR, FIXED <del>ELECTROLYTIC</del> <sup>"</sup> : 39 MF ± 10% 10 VDC MIL Type <del>CS13BB396K</del> "	5-10
2A1A3CR1		DIODE: MIL Type 1N3611	5-10
2A1A3CR2		DIODE: MIL Type 1N3611	5-10
2A1A3CR3		DIODE: MIL Type 1N3611	5-10
2A1A3CR4		DIODE: MIL Type <del>1N3611</del> IN 486B	5-10
2A1A3CR5		DIODE: MIL Type 1N3611	5-10
2A1A3CR6		DIODE: MIL Type 1N3611	5-10

TABLE 6-2. MAINTENANCE PARTS LIST (Con't)

REF	DESIG	NOTE	NAME AND DESCRIPTION	FIG.
2A1A3CR7			DIODE: MIL Type 1N3611	5-10
2A1A3CR8			DIODE: MIL Type 1N3611	5-10
2A1A3CR9			Not Used.	5-10
2A1A3CR10			Not Used.	
2A1A3CR11			Not Used.	
2A1A3CR12			DIODE: MIL Type 1N3611	5-10
2A1A3CR13			DIODE: MIL Type 1N3611	5-10
2A1A3CR14			DIODE: MIL Type 1N3611	5-10
2A1A3CR15			DIODE: MIL Type 1N3611	5-10
2A1A3CR156			DIODE: MIL Type 1N3611	5-10
2A1A3MP1			POWER SUPPLY PCB: Mfr. 14304, P/N 392-6601	5-10
2A1A3Q1			TRANSISTOR: MIL Type 2N2219 (Replace with 2N2102)	5-10
2A1A3Q2			TRANSISTOR: MIL Type 2N1613 (Replace with 2N2102)	5-10
2A1A3Q3			TRANSISTOR: MIL Type 2N1613 (Replace with 2N2102)	5-10
2A1A3Q4			TRANSISTOR: MIL Type 2N1613 (Replace with 2N2102)	5-10
2A1A3Q5			TRANSISTOR: MIL Type 2N2219 (Replace with 2N2102)	5-10
2A1A3Q6			TRANSISTOR: MIL Type 2N2219 (Replace with 2N2102)	5-10
2A1A3Q7	FC 2		TRANSISTOR: MIL Type 2N2102	5-10
2A1A3Q8			TRANSISTOR: MIL Type 2N2102	5-10
2A1A3Q9			TRANSISTOR: MIL Type 2N2219 (Replace with 2N2102)	5-10
2A1A3R1			RESISTOR, FIXED COMPOSITION: 390 Ohms $\pm$ 10% $\frac{1}{2}$ Watt MIL Type RC07GF391K	5-10
2A1A3R2			RESISTOR, FIXED COMPOSITION: 820 Ohms $\pm$ 10% $\frac{1}{2}$ Watt MIL Type RC07GF821K	5-10
2A1A3R3			RESISTOR, FIXED COMPOSITION: 1000 Ohms $\pm$ 10% 2 Watt MIL Type RC42GF102K	5-10

TABLE 6-2. MAINTENANCE PARTS LIST (Con't)

REF DESIG	NOTE	NAME AND DESCRIPTION	FIG.
2A1A3R4		RESISTOR, FIXED COMPOSITION: 2200 Ohms $\pm$ 10%, $\frac{1}{2}$ Watt MIL Type RC20GF222K	5-10
2A1A3R5		Not Used.	
2A1A3R6		RESISTOR, FIXED COMPOSITION: 1500 Ohms $\pm$ 10%, $\frac{1}{2}$ Watt MIL Type RC20GF152K	5-10
2A1A3R7		Not Used.	
2A1A3R8		RESISTOR, FIXED COMPOSITION: 820 Ohms $\pm$ 10%, 2 Watt MIL Type RC42GF821K	5-10
2A1A3R9		RESISTOR, FIXED COMPOSITION: 10K Ohms $\pm$ 10%, 2 Watt MIL Type RC42GF103K	5-10
2A1A3R10		RESISTOR, FIXED COMPOSITION: 22K Ohms $\pm$ 10%, $\frac{1}{2}$ Watt MIL Type RC20GF223K	5-10
2A1A3R11		Not Used.	
2A1A3R12		RESISTOR, FIXED COMPOSITION: 4700 Ohms $\pm$ 10%, $\frac{1}{2}$ Watt MIL Type RC07GF472K	5-10
2A1A3R13		RESISTOR, FIXED COMPOSITION: 1000 Ohms $\pm$ 10%, $\frac{1}{2}$ Watt MIL Type RC07GF102K	5-10
2A1A3R14		RESISTOR, FIXED COMPOSITION: 6800 Ohms $\pm$ 10%, $\frac{1}{2}$ Watt MIL Type RC07GF682K	5-10
2A1A3R15		RESISTOR, FIXED COMPOSITION: 3300 Ohms $\pm$ 10%, $\frac{1}{2}$ Watt MIL Type RC07GF332K	2-10
2A1A3R16		Not Used.	
2A1A3R17		RESISTOR, FIXED COMPOSITION: 2200 Ohms $\pm$ 10%, $\frac{1}{2}$ Watt MIL Type RC20GF222K	2-10
2A1A3R18		RESISTOR, FIXED COMPOSITION: 820 Ohms $\pm$ 10%, 2 Watt MIL Type RC42GF821K	2-10
2A1A3R19		RESISTOR, FIXED COMPOSITION: <sup>3300</sup> <del>1000</del> Ohms, $\pm$ 10%, 2 Watt MIL Type RC42GF <del>102K</del> 332K	2-10
2A1A3R20		RESISTOR, FIXED COMPOSITION: 2200 Ohms $\pm$ 10%, $\frac{1}{2}$ Watt MIL Type RC07GF222K	2-10
2A1A3R21		RESISTOR, FIXED COMPOSITION: 4700 Ohms $\pm$ 10%, $\frac{1}{2}$ Watt MIL Type RC07GF472K	2-10

TABLE 6-2. MAINTENANCE PARTS LIST (Con't)

REF. DESIG	NOTE	NAME AND DESCRIPTION	FIG.
2A1A3R22		RESISTOR, FIXED COMPOSITION: 47 Ohm $\pm$ 10%, $\frac{1}{2}$ Watt MIL Type RC07GF470K	2-10
2A1A3R23		RESISTOR, FIXED COMPOSITION: 1000 Ohms $\pm$ 10%, $\frac{1}{2}$ Watt MIL Type RC07GF102K	2-10
2A1A3R24		Not Used.	
2A1A3R25		Not Used.	
2A1A3R26		RESISTOR, FIXED COMPOSITION: 15 Ohms $\pm$ 10%, 2 Watt MIL Type RC42GF150 K	2-10
2A1A3R27		Not Used.	
2A1A3R28		RESISTOR, FIXED COMPOSITION: 15 Ohms @ 10%, 2 Watt MIL Type RC42GF150K	5-10
2A1A3R29		Not Used.	
2A1A3R30		RESISTOR, FIXED COMPOSITION: 6800 Ohms $\pm$ 10%, $\frac{1}{2}$ Watt MIL Type RC07GF682K	5-10
2A1A3R31		RESISTOR, FIXED COMPOSITION: 1800 Ohms $\pm$ 10%, 1 Watt MIL Type RC32GF182K	5-10
2A1A3R32		RESISTOR, FIXED COMPOSITION: 1800 Ohms $\pm$ 10%, 1 Watt MIL Type RC32GF182K	5-10
2A1A3R33		RESISTOR, FIXED COMPOSITION: 3300 Ohms $\pm$ 10%, $\frac{1}{2}$ Watt MIL Type RC07GF332K	5-10
2A1A3R34		RESISTOR, FIXED COMPOSITION: 1000 Ohms $\pm$ 10%, $\frac{1}{2}$ Watt MIL Type RC07GF102K	5-10
2A1A3R35		RESISTOR, FIXED COMPOSITION: 4700 Ohms $\pm$ 10%, $\frac{1}{2}$ Watt MIL Type RC07GF472K	5-10
2A1A3R36		RESISTOR, FIXED COMPOSITION: 10 Ohms $\pm$ 10%, $\frac{1}{2}$ Watt MIL Type RC07GF100K	5-10
2A1A3R37		RESISTOR, FIXED FILM: 2400 Ohms, $\frac{1}{2}$ Watt MIL Type RL20AD242G	5-10
2A1A3R38	Not Used	<del>RESISTOR, FIXED COMPOSITION: 1000 Ohms <math>\pm</math> 10%, <math>\frac{1}{2}</math> Watt MIL Type RC07GF102K</del>	5-10
2A1A3R39		RESISTOR, FIXED COMPOSITION: 1800 Ohms $\pm$ 10%, 1 Watt MIL Type RC32GF182K	5-10

TABLE 6-2. MAINTENANCE PARTS LIST (Con't)

REF DESIG	NOTE	NAME AND DESCRIPTION	FIG.
2A1A3R40		RESISTOR, FIXED COMPOSITION: 1800 Ohms $\pm$ 10%, 1 Watt MIL Type RC32GF182K	5-10
2A1A3TP1		JACK, TEST: Mfr. 74970, P/N 105-75 <sup>8</sup>	5-10
2A1A3TP2		JACK, TEST: Mfr. 74970, P/N 105-75 <sup>2</sup>	5-10
2A1A3TP3		JACK, TEST: Mfr. 74970, P/N 105-75 <sup>6</sup>	5-10
2A1A3TP4		JACK, TEST: Mfr. 74970, P/N 105-757	5-10
2A1A3VR1		DIODE: MIL Type 1N753A	5-10
2A1A3VR2		DIODE: MIL Type 1N753A	5-10
2A1A3VR3		DIODE: MIL Type 1N753A	5-10
2A1A3VR4		DIODE: MIL Type 1N753A	5-10
2A1A3VR5		DIODE: MIL Type 1N967B	5-10
2A1A3VR6		DIODE: MIL Type 1N967B	5-10
2A1A4		LOGIC PCB ASSEMBLY: Mfr. 14304, P/N 392-6700	5-8
2A1A4C1		Not Used.	
2A1A4C2		Not Used.	
2A1A4C3		CAPACITOR, FIXED ELECTROLYTIC: 39 MF $\pm$ 10% 10 VDC MIL Type 13BC396K	5-11
2A1A4C4		CAPACITOR, FIXED ELECTROLYTIC: 10 MF $\pm$ 10% 25 VDC MIL Type CS13BE106K	5-11
2A1A4C5		CAPACITOR, FIXED CERAMIC: 8200 MF $\pm$ 20% MIL Type CK62AW8822M	5-11
2A1A4C6		CAPACITOR, FIXED CERAMIC: 8200 PF $\pm$ 20% MIL Type CK62AW8822M	5-11
2A1A4C7		CAPACITOR, FIXED CERAMIC: 8200 PF $\pm$ 20% MIL Type CK62AW8822M	5-11
2A1A4C8		CAPACITOR, FIXED CERAMIC: 8200 PF $\pm$ 20% MIL Type CK62AW8822M	5-11
2A1A4C9		CAPACITOR, FIXED CERAMIC: 8200 PF $\pm$ 20% MIL Type CK62AW8822M	5-11
2A1A4CR1		Not Used.	



TABLE 6-2. MAINTENANCE PARTS LIST (Con't)

REF	DESIG	NOTE	NAME AND DESCRIPTION	FIG.
	2A1A4CR2		DIODE: MIL Type 1N486B	5-11
	2A1A4CR3		DIODE: MIL Type 1N486B	5-11
	2A1A4CR4		DIODE: MIL Type 1N486B	5-11
	2A1A4CR5		DIODE: MIL Type 1N486B	5-11
	2A1A4CR6		DIODE: MIL Type 1N486B	5-11
	2A1A4CR7		DIODE: MIL Type 1N486B	5-11
	2A1A4CR8		DIODE: MIL Type 1N486B	5-11
	2A1A4CR9		DIODE: MIL Type 1N486B	5-11
	2A1A4CR10		DIODE: MIL Type 1N486B	5-11
	2A1A4CR11		DIODE: MIL Type 1N486B	5-11
	2A1A4CR12		DIODE: MIL Type 1N486B	5-11
	2A1A4CR13		DIODE: MIL Type 1N486B	5-11
	2A1A4CR14		Not Used.	
	2A1A4CR15		Not Used.	
	2A1A4CR16		DIODE: MIL Type 1N3611	5-11
	2A1A4CR17		DIODE: MIL Type 1N486B	5-11
	2A1A4MP1		LOGIC PCB: Mfr. 14304, P/N 392-6701	5-11
	2A1A4Q1		TRANSISTOR: MIL Type 2N1613 (Replace with 2N2102)	5-11
	2A1A4Q2		TRANSISTOR: MIL Type 2N1613 (Replace with 2N2102)	5-11
	2A1A4Q3		TRANSISTOR: MIL Type 2N1613 (Replace with 2N2102)	5-11
	2A1A4Q4		TRANSISTOR: MIL Type 2N1613 (Replace with 2N2102)	5-11
	2A1A4Q5		TRANSISTOR: MIL Type 2N1613 (Replace with 2N2102)	5-11
	2A1A4Q6		TRANSISTOR: MIL Type 2N1613 (Replace with 2N2102)	5-11
	2A1A4R1		Not Used.	
	2A1A4R2		Not Used.	
	2A1A4R3		Not Used.	
	2A1A4R4		Not Used.	

TABLE 6-2. MAINTENANCE PARTS LIST (Con't)

REF DESIG	NOTE	NAME AND DESCRIPTION	FIG.
2A1A4R5		RESISTOR, FIXED COMPOSITION: 3300 Ohms $\pm$ 10%, $\frac{1}{2}$ Watt MIL Type RC07GF332K	5-11
2A1A4R6		RESISTOR, FIXED COMPOSITION: 3300 Ohms $\pm$ 10%, $\frac{1}{2}$ Watt MIL Type RC07GF332K	5-11
2A1A4R7		RESISTOR, FIXED COMPOSITION: 4700 Ohms $\pm$ 10%, $\frac{1}{2}$ Watt MIL Type RC07GF472K	5-11
2A1A4R8		RESISTOR, FIXED COMPOSITION: 2200 Ohms $\pm$ 10%, $\frac{1}{2}$ Watt MIL Type RC20GF222K	5-11
2A1A4R9		RESISTOR, FIXED COMPOSITION: 4700 Ohms $\pm$ 10%, $\frac{1}{2}$ Watt MIL Type RC <del>20</del> GF472K 07	5-11
2A1A4R10		RESISTOR, FIXED COMPOSITION: 1200 Ohms $\pm$ 10%, $\frac{1}{2}$ Watt MIL Type RC07GF122K	5-11
2A1A4R11		RESISTOR, FIXED COMPOSITION: 1000 Ohms $\pm$ 10%, $\frac{1}{2}$ Watt MIL Type RC07GF102K	5-11
2A1A4R12		RESISTOR, FIXED COMPOSITION: 4700 Ohms $\pm$ 10%, $\frac{1}{2}$ Watt MIL Type RC07GF472K	5-11
2A1A4R13		RESISTOR, FIXED COMPOSITION: 1800 Ohms $\pm$ 10%, 1 Watt MIL Type RC32GF182K	5-11
2A1A4R14		RESISTOR, FIXED COMPOSITION: 3900 Ohms $\pm$ 10%, $\frac{1}{2}$ Watt MIL Type RC07GF392K	5-11
2A1A4R15		RESISTOR, FIXED COMPOSITION: 2700 Ohms $\pm$ 10%, $\frac{1}{2}$ Watt MIL Type RC20GF272K	5-11
2A1A4R16		RESISTOR, FIXED COMPOSITION: 10K Ohms $\pm$ 10%, 2 Watt MIL Type RC <del>20</del> GF103K 07	5-11
2A1A4R17		RESISTOR, FIXED COMPOSITION: 3300 Ohms $\pm$ 10%, $\frac{1}{2}$ Watt MIL Type RC07GF332K	5-11
2A1A4R18		RESISTOR, FIXED COMPOSITION: 4700 Ohms $\pm$ 10%, $\frac{1}{2}$ Watt MIL Type RC07GF472K	5-11
2A1A4R19		RESISTOR, FIXED COMPOSITION: 1000 Ohms $\pm$ 10%, $\frac{1}{2}$ Watt MIL Type RC07GF102K	5-11
2A1A4R20		RESISTOR, FIXED COMPOSITION: 100 Ohms $\pm$ 10%, $\frac{1}{2}$ Watt MIL Type RC07GF101K	5-11
2A1A4R21		RESISTOR, FIXED COMPOSITION: 4700 Ohms $\pm$ 10%, $\frac{1}{2}$ Watt MIL Type RC07GF472K	5-11

TABLE 6-2. MAINTENANCE PARTS LIST (Con't)

REF DESIG	NOTE	NAME AND DESCRIPTION	FIG.
2A1A4R22		RESISTOR, FIXED COMPOSITION: 1800 Ohms $\pm$ 10%, $\frac{1}{2}$ Watt MIL Type RC07GF182K	5-11
2A1A4R23		Not Used.	
2A1A4R24		RESISTOR, FIXED COMPOSITION: 1000 Ohms $\pm$ 10%, $\frac{1}{2}$ Watt MIL Type RC07GF102K	5-11
2A1A4R25		RESISTOR, FIXED COMPOSITION: 15K Ohms $\pm$ 10%, $\frac{1}{2}$ Watt MIL Type RC07GF153K	5-11
2A1A4R26		RESISTOR, FIXED COMPOSITION: 1500 Ohms $\pm$ 10%, $\frac{1}{2}$ Watt MIL Type RC07GF152K 682	5-11
2A1A4R27		RESISTOR, FIXED COMPOSITION: 1500 Ohms $\pm$ 10%, $\frac{1}{2}$ Watt MIL Type RC07GF152K	5-11
2A1A4R28		RESISTOR, FIXED COMPOSITION: 6800 Ohms $\pm$ 10%, $\frac{1}{2}$ Watt MIL Type RC07GF682K	5-11
2A1A4R29		Not Used.	
2A1A4R30		Not Used.	
2A1A4R31		RESISTOR, FIXED COMPOSITION: 1800 Ohms $\pm$ 10%, $\frac{1}{2}$ Watt MIL Type RC07GF182K	5-11
2A1A4R32		Not Used.	
2A1A4R33		RESISTOR, FIXED COMPOSITIO@: 4700 Ohms $\pm$ 10%, $\frac{1}{2}$ Watt MIL Type RC07GF472K	5-11
2A1A4TP1		JACK, TEST: Mfr. 74970, P/N 105-75 <sup>8</sup>	5-11
2A1A4TP2		JACK, TEST: Mfr. 74970, P/N 105-75 <sup>2</sup>	5-11
2A1A4TP3		JACK, TEST: Mfr. 74970, P/N 105-75 <sup>6</sup>	5-11
2A1A4TP4		JACK, TEST: Mfr. 74970, P/N 105-757	5-11
2A2		CASE ASSEMBLY: Mfr. 14304, P/N 392-6200	5-12
2A2A1		FILTER BOX ASSEMBLY: Mfr. 14304, P/N 392-6300	5-12
2A2A1C1		CAPACITOR, FEED THRU: 1500 PF $\pm$ 20% 500 V MIL Type CK70AW152M	5-12
2A2A1C2		CAPACITOR, FEED THRU: 1500 PF $\pm$ 20% 500 V MIL Type CK70AW152M	5-12

TABLE 6-2. MAINTENANCE PARTS LIST (Continued)

REF DESIG	NOTE	NAME AND DESCRIPTION	FIG.
2A2A1C3		CAPACITOR, FEED THRU: 1500 PF $\pm$ 20% 500V, Mil type CK70AW152M	5-12
2A2A1C4		CAPACITOR, FEED THRU: 1500 PF $\pm$ 20% 500V, Mil type CK70AW152M	5-12
2A2A1C5		CAPACITOR, FEED THRU: 1500 PF $\pm$ 20% 500V, Mil type CK70AW152M	5-12
2A2A1C6		CAPACITOR, FEED THRU: 1500 PF $\pm$ 20% 500V, Mil type CK70AW152M	5-12
2A2A1C7		CAPACITOR, FEED THRU: 1500 PF $\pm$ 20% 500V, Mil type CK70AW152M	5-12
2A2A1C8		CAPACITOR, FIXED PAPER: 0.1 UF 400VDC Mfr 02777, P14D	5-12
2A2A1J1		CONNECTOR, RECEPTACLE: Mil type MS3102R-20-27P	5-12
2A21J2		CONNECTOR, RECEPTACLE: Mil type MS3102R-28-21S	5-12
ANCILLARY ITEMS			
P1		CONNECTOR, PLUG: MIL TYPE 10-109628-21S	
P2		CONNECTOR, PLUG: MIL TYPE 10-10928-21P	
P3		CONNECTOR, PLUG: MIL TYPE UG-982/U	
W1		CABLE ASSEMBLY W1: Mfr 14304 PN 399-0028	

TABLE 6-3. LIST OF MANUFACTURERS

MFR CODE	NAME	ADDRESS
00656	Aerovox Corp.	New Bedford, Mass.
12143	Bendix Corp. , Scintilla Division	Santa Ana, California
✓ 14304	R F Communications, Inc.	Rochester, New York
18787	Electropac, Inc.	Peterborough, N. H.
71688	Cook Electric Company	Chicago, Illinois
74970	E. F. Johnson, Co.	Waseca, Minn.
75382	Kulka Electric Corp.	Mt. Vernon, New York
83086	New Hampshire Ball Bearings Inc.	Peterborough, N. H.
91816	Circle Seal Products Co.	Pasadena, California
05327	National Beryllia Corp.	Haskell, New Jersey
50097	Radionics Inc.	Webster, New York

TABLE 6-2. MAINTENANCE PARTS LIST

REF DESIG	NOTE	NAME AND DESCRIPTION	FIG.
1A2MP8	FC-3	Actuator, Microswitch, JS-5	5-6
1A2MP9	FC-3	End-Stop (P/O Inductor Assy 1A2L1) NAVSHIPS Dwg 450-SK2100013	5-7
1A2MP10	FC-3	Bracket Assy NAVSHIPS Dwg 450-SK210015	5-6
2A1DS1		Lamp, Incandescent, MIL Type MS25237-327T (Replace with MS18209-387)	5-8
2A1DS2		Lamp, Incandescent, MIL Type MS25237-327T (Replace with MS18209-387)	5-8
2A1DS3		Lamp, Incandescent, MIL Type MS25237-327T (Replace with MS18209-387)	5-8
2A1DS4		Lamp, Incandescent, MIL Type MS25237-327T (Replace with MS18209-387)	5-8
2A1DS6		Lamp, Incandescent, MIL Type MS25237-327T (Replace with MS18209-387)	
2A1L1		Inductor 22UH MIL Type MS16221-15	5-8
2A1MP1		Knob	5-8
2A1MP2		Knob	3-1
2A1S11		Switch, Interlock, MIL Type MS16106-4	5-8

Change 3

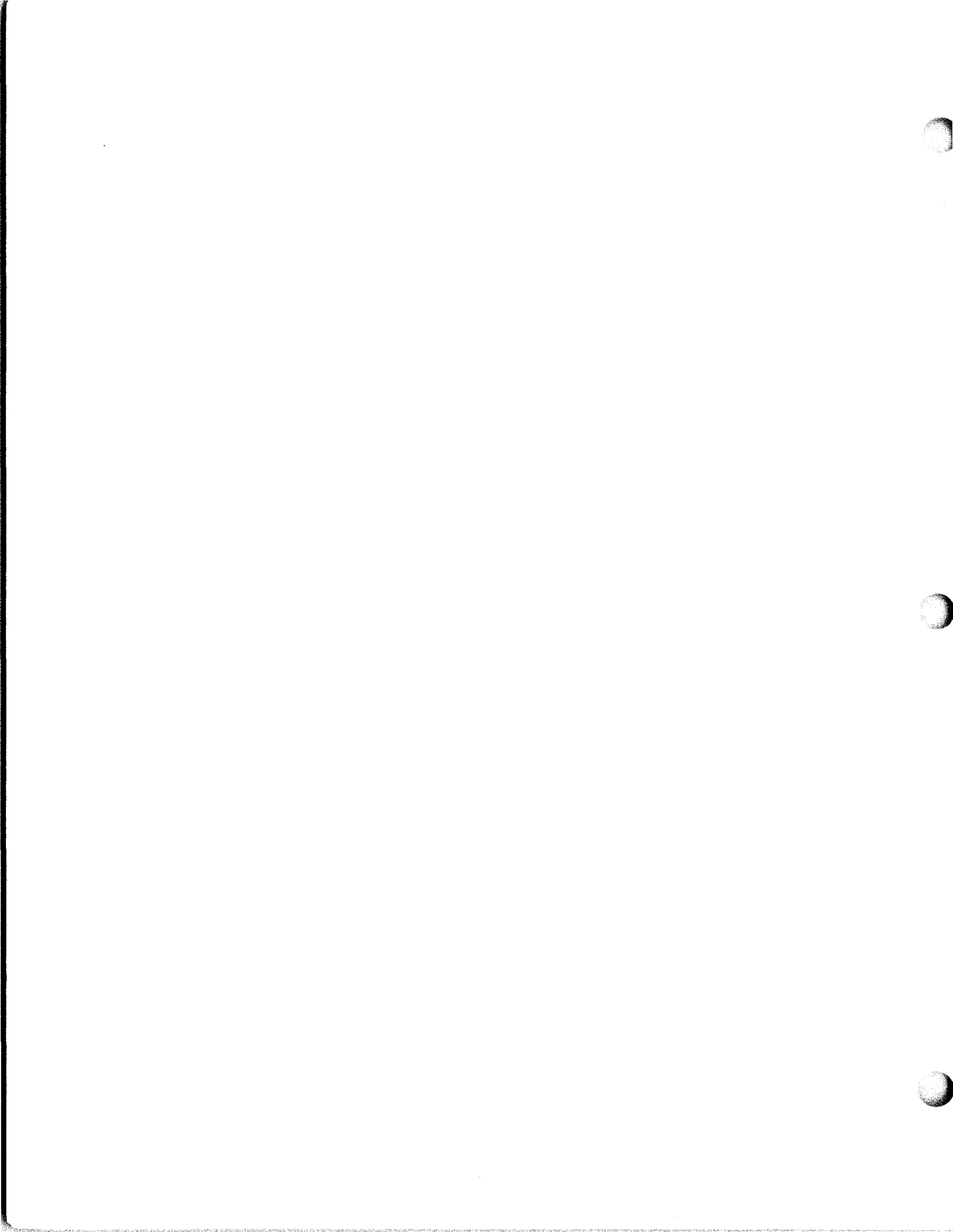

NAVSHIPS NO. \_\_\_\_\_ USER ACTIVITY COMMENT SHEET

Vol. No. \_\_\_\_\_

(Fold on dotted lines on reverse side,  
staple in corner, and send to Naval  
Ship Engineering Center, Washington  
D.C. 20360)

PROBLEM AREA:

Both sides of this form to be reproduced locally as required.



FOLD

DEPARTMENT OF THE NAVY  
NAVAL SHIP ENGINEERING CENTER  
WASHINGTON, D.C. 20360

POSTAGE AND FEES PAID  
NAVY DEPARTMENT

OFFICIAL BUSINESS

COMMANDER, NAVAL SHIP ENGINEERING CENTER  
FLEET ELECTRONICS EFFECTIVENESS BRANCH  
ELECTRONICS PUBLICATIONS SECTION  
DEPARTMENT OF THE NAVY  
WASHINGTON, D. C. 20360

FOLD