

★
NAVSHIPS 0967-340-0010

TECHNICAL MANUAL
for
COMPARATOR-
CONVERTER GROUP
AN/URA-17C

DEPARTMENT OF THE NAVY
NAVAL ELECTRONIC SYSTEMS COMMAND

★
PUBLICATION DATE: 24 OCTOBER 1968

RECORD OF CORRECTIONS MADE

CHANGE NO.	DATE	FIELD CHANGE NO.	SIGNATURE

TABLE OF CONTENTS

SECTION 1—GENERAL INFORMATION		SECTION 2—INSTALLATION (Continued)	
Paragraph	Page	Paragraph	Page
1-1.	Equipment Illustration.....	1-1	
1-2.	Functional Description.....	1-1	
1-3.	Description of the Major Unit.....	1-1	
1-4.	Factory or Field Changes.....	1-1	
1-5.	Quick Reference Data.....	1-1	
	a. AF Input Signal.....	1-1	
	b. Operating Frequencies.....	1-3	
	c. Maximum Keying Speeds.....	1-3	
	d. Output.....	1-3	
	e. Power Source Requirements.....	1-3	
1-6.	Equipment Lists.....	1-3	
	a. Equipment Supplied.....	1-3	
	b. Equipment and Publications Required but not Supplied.....	1-3	
	c. Test Equipment Required but not Supplied.....	1-3	
	d. Shipping Data.....	1-3	
	e. Equipment Similarities.....	1-3	
	f. Transistor and Diode Complement.....	1-3	
 SECTION 2—INSTALLATION			
2-1.	Unpacking and Handling.....	2-1	
2-2.	Power Requirements and Distribution.....	2-1	
2-3.	Installation Layout.....	2-1	
2-4.	Installation Requirements.....	2-1	
	a. Outline Drawings.....	2-1	
	b. Equipment Mounting.....	2-1	
	(1) Table-Mounting the AN/URA-17C.....	2-1	
	(2) Table-Mounting the CV-483C/URA-17.....	2-1	
	(3) Rack-Mounting the AN/URA-17C.....	2-1	
	(4) Rack-Mounting the CV-483C/URA-17.....	2-2	
	c. Interconnection.....	2-2	
	(1) Interconnecting Cables for Single-Receiver Operation.....	2-3	
	(2) Interconnecting Cables for Diversity Operation.....	2-3	
	(3) Audio Input Lines.....	2-3	
	(4) Power Transformer Connections.....	2-3	
	d. Cable Assembly.....	2-4	
	(1) Attaching UG-88D/U Connectors to RG-58A/U Coaxial Cable.....	2-4	
	(2) Attaching MS Connector to MCOS-2 Cable.....	2-4	
	(3) Attaching MS Connectors to TTHFWA-1-l/2 Cable.....	2-6	
	2-5. Inspection and Adjustments.....	2-7	
	a. Mechanical and Electrical Checks.....	2-7	
	(1) Mechanical Checks.....	2-7	
	(2) Electrical Checks.....	2-7	
	(a) CRT Adjustment Controls.....	2-9	
	(b) Pre-Operational Check.....	2-9	
	(c) Operational Check.....	2-9	
	2-6. Preparation for Reshipment.....	2-9	
	a. Interconnecting Cables.....	2-9	
	b. Dismounting Equipment.....	2-9	
	c. Packing.....	2-9	
 SECTION 3—OPERATOR'S SECTION			
	3-1. Functional Operation.....	3-1	
	a. General.....	3-1	
	b. Frequency-Shift Method of Communication.....	3-1	
	c. Diversity Operation.....	3-1	
	d. Single-Receiver Operation.....	3-1	
	3-2. Operating Procedures.....	3-1	
	a. General.....	3-1	
	b. Description of Controls.....	3-1	
	c. Sequence of Operation.....	3-1	
	(1) Before Use.....	3-1	
	(2) During Use.....	3-1	
	(3) Secure.....	3-1	
	d. Indicator Presentations.....	3-1	
	e. Tuning Adjustments.....	3-1	
	(1) Single-Receiver Operation.....	3-1	
	(2) Diversity Operation.....	3-1	
	f. Illustrations.....	3-3	
	(1) Controls.....	3-3	
	(2) Indicator Presentation.....	3-3	
	g. Modes of Operation.....	3-3	
	(1) Single-Receiver Operation.....	3-3	
	(2) Diversity Operation.....	3-3	
	3-3. Summary of Operating Procedures.....	3-4	
	a. Single-Receiver Operation.....	3-4	
	b. To Secure.....	3-4	
	c. Diversity Operation.....	3-5	
	d. To Secure.....	3-5	
	3-4. Operator's Maintenance.....	3-5	
	a. General.....	3-6	
	b. Routine Check Chart.....	3-6	
	c. Daily Check for Correct Diversity Operation.....	3-6	
	d. Indicator Lamp Replacement.....	3-7	
	e. Fuse Replacement.....	3-7	
	f. Emergency Maintenance.....	3-7	

SECTION 4-PRINCIPLES OF OPERATION

SECTION 5-TROUBLE-SHOOTING (Conitnued)

Paragraph	Page
4-1. Overall Functional Description.....	4-0
a. General.....	4-0
b. Diversity Operation.....	4-0
c. Single-Receiver Operation.....	4-0
d. Simplified Block Diagram.....	4-0
e. Functional Block Diagram.....	4-0
4-2 Functional Sections.....	4-0
a. General.....	4-0
b. Signal Processing Circuits.....	4-0
(1) Bandpass Filters.....	4-1
(2) Limiter.....	4-1
(3) Discriminators.....	4-1
(4) Mark-Space Amplifiers.....	4-1
(5) Detector.....	4-1
(6) Keying Filter.....	4-3
c. Keyer Circuits.....	4-4
(1) DC Differential Amplifier.....	4-4
(2) Axis Restorer.....	4-4
(3) Comparator.....	4-4
(4) DC Limiter.....	4-4
(5) Loop Keyer.....	4-5
(6) Mark Lock-Up.....	4-5
(7) Tuning Indicator.....	4-5
d. Power Supplies.....	4-5
(1) +48 Volt Supply.....	4-5
(2) -48 Volt Supply.....	4-6
(3) -560 Volt Supply.....	4-6

SECTION 5- TROUBLE-SHOOTING

5-1. General.....	5-1
5-2. Test Equipment and Special Tools.....	5-1
a. Test Equipment.....	5-1
b. Special Tools.....	5-1
5-3 Overall Trouble-Shooting.....	5-1
a. Preliminary Check.....	5-1
b. Test Equipment and Special Tools.....	5-1
c. Control Settings.....	5-1
d. System Trouble-Shooting Chart.....	5-2
(1) Malfunction During Single-Receiver Operation.....	5-2
(2) Malfunction During Diversity Operation.....	5-2
5-4 Functional Section Trouble-Shooting.....	5-2
a. General.....	5-3
b. Signal Processing Circuits Trouble-Shooting.....	5-3
(1) Preliminary Check.....	5-3

Paragraph	Page
(2) Test Equipment and Special Tools.....	5-3
(a) Test Equipment.....	5-3
(b) Special Tools.....	5-3
(3) Control Settings.....	5-3
(4) Illustrations.....	5-4
(a) Test Points.....	5-4
(b) Schematic Diagrams.....	5-4
(c) Voltage and Resistance Diagram.....	5-4
(d) Signal Tracing Oscilloscope Patterns.....	5-4
(e) Alignment of the Converter after Trouble-Shooting..	5-4
c. Keyer Circuits Trouble-Shooting.....	5-4
(1) Preliminary Check.....	5-4
(2) Test Equipment and Special Tools.....	5-4
(a) Test Equipment.....	5-4
(b) Special Tools.....	5-6
(3) Control Settings..	5-6
(4) Illustrations.....	5-6
(a) Test Points.....	5-6
(b) Schematic Diagrams.....	5-6
(c) Voltage and Resistance Diagram.....	5-6
(d) Signal Tracing Oscilloscope Patterns.....	5-6
(e) Alignment of the Converter After Trouble-Shooting..	5-6
d. Power Supplies Trouble-Shooting.....	5-7
(1) Preliminary Check.....	5-7
(2) Test Equipment and Special Tools... ..	5-7
(a) Test Equipment.....	5-7
(b) Special Tools... ..	5-7
(3) Control Settings.....	5-7
(4) Illustrations.....	5-15
(a) Test Points.....	5-15
(b) Schematic Diagrams.....	5-15
5-5. Typical Troubles.....	5-15
5-6. Location of Parts.....	5-15

SECTION 6-REPAIR

6-1. Failure Report.....	6-0
6-2. Tuning and Adjustment.....	6-0
a. General.....	6-0
b. Standards.....	6-0
c. Test Equipment and Special Tools.....	6-0

SECTION 6-REPAIR (Continued)

- d. Special Jigs..... 6-0
- e. Control Settings..... 6-0
- f. Power Supply Adjustments..... 6-0
 - (1) +48 Volt Supply..... 6-0
 - (2) -48 Volt Supply..... 6-1
- g. Cathode-Ray Tube Adjustments..... 6-1
- h. Mark and Space Gain Control Adjustments..... 6-1
- i. DC Differential Amplifier Adjustments..... 6-2
- 6-3. Removal, Adjustment, Repair, and Reassembly..... 6-2
 - a. General..... 6-2
 - b. Illustrations..... 6-2
 - (1) Photographs..... 6-2
 - (2) Wiring Diagrams..... 6-2
 - c. Removal and Reassembly..... 6-2
 - (1) Chassis Removal..... 6-2
 - (2) Transformer and Filter Replacement..... 6-3
 - (3) Printed Circuit Board Replacement..... 6-3
 - (4) Receptacle Panel Removal..... 6-3
 - d. Adjustment and Repair..... 6-3
 - (1) Test Equipment and Special Tools..... 6-3

SECTION 6-REPAIR (Continued)

- (2) Transistor Replacement..... 6-3
- (3) Tuning Indicator Cathode-Ray Tube Replacement..... 6-3
- (4) Transistor Socket Replacement..... 6-3
- (5) Rotary Switch Repairs..... 6-3
 - (a) Replacing Defective Switch Wafer..... 6-3
 - (b) Replacing Defective Switch..... 6-4
- (6) Bandpass Filter Tests..... 6-4
 - (a) Wide-Shift Filter FL1..... 6-4
 - (b) Narrow-Shift Filter (Part of Z1)..... 6-4
- (7) Discriminator Tests..... 6-6
 - (a) Wide-Shift Discriminator..... 6-6
 - (b) Narrow-Shift Discriminator..... 6-6
- (8) Low-Pass Keying Filter Tests..... 6-7

SECTION 7-PARTS LIST

- 7-1. Introduction..... 7-1
- 7-2. Maintenance Parts List..... 7-1
- 7-3. List of Manufacturers..... 7-1
- 7-4. Notes..... 7-1

LIST OF ILLUSTRATIONS

SECTION 1-GENERAL INFORMATION		SECTION 3- OPERATOR'S SECTION (Continued)	
Figure	Page	Figure	Page
1-1	Comparator-Converter Group AN/URA-17C, Equipment Supplied.....		Converter Group for Daily Check of Diversity Operation.....
	1-0		3-7
1-2	Frequency Shift Converter CV-483C/URA-17, Top View, Chassis Fully Withdrawn.....		
	1-2		
SECTION 2-INSTALLATION		SECTION 4- PRINCIPLES OF OPERATION	
2-1	Comparator-Converter Group AN/URA-17C, Table- Mounting Installation Drawing...	4-1.	Frequency-Shift Receiving System, Simplified Block Diagram.....
	2-2		4-1
2-2	Frequency Shift Converter CV-483C/URA-17, Table- Mounting Installation Drawing....	4-2	Comparator-Converter Group AN/URA-17C, Functional Block Diagram.....
	2-3		4-2
2-3	Frequency Shift Converter CV-483C/URA-17, Rack- Mounting Installation Drawing...	4-3	Discriminator Response Curves.....
	2-4	4-4	Discriminator Detector, Simplified Diagram.....
2-4	Frequency Shift Converter CV-483C/URA-17, Inter- connecting Data for Single- Receiver Operation.....	4-5	Comparator Circuit, Simplified Schematic Diagram.....
	2-5	4-6	Loop Keyer and Teletype Printer Keying Circuits.....
2-5	Comparator-Converter Group AN/URA-17C, Interconnecting Data for Diversity Operation...		
	2-6		
2-6	Frequency Shift Converter CV-483C/URA-17, Cable Recep- tacle Panel, Interior View.....		
	2-8		
2-7	Attaching UG-88D/U Plug to RG-58A/U Coaxial Cable.....		
	2-10		
2-8	Attaching MS Plug to MCOS-2 Cable.		
	2-11		
2-9	Attaching MS Plug to TTHFWA-1- 1-1/2 Cable.....		
	2-11		
2-10	Location of Cathode-Ray Tube Controls.....		
	2-12		
2-11	Teletype Printer DC Keying Relay Circuit, Simplified Schematic Diagram.....		
	2-12		
SECTION 3-OPERATOR'S SECTION		SECTION 5-TROUBLE-SHOOTING	
3-1.	Frequency Shift Converter CV-483C/URA-17, Front Panel Controls.....	5-1	Frequency Shift Converter CV-483C/URA-17, Parts Location.....
	3-2		5-3
3-2	Tuning Indicator Patterns.....	5-2	Frequency Shift Converter CV-483C/URA-17, Location of Test Points.....
	3-3		5-4
3-3	Connections between Receiver, Teletype Printer, and	5-3.	Frequency Shift Converter CV-483C/URA-17, Signal Processing Circuits, Voltage and Resistance Measurements.....
			5-7
		5-4	Frequency Shift Converter CV-483C/URA-17, Signal Processing Circuits, Functional Schematic Diagram....
			5-9/5-10
		5-5	Frequency Shift Converter CV-483C/URA-17, Keyer Circuits, Voltage and Resistance Measurements
			5-11
		5-6	Frequency Shift Converter CV-483C/URA-17, Keyer Circuits, Functional Schematic Diagram.....
			5-13/5-14
		5-7	Frequency Shift Converter CV-483C/URA-17, Primary Power Distribution Diagram.....
			5-15
		5-8	Frequency Shift Converter CV-483C/ URA-17, Power Supplies, Functional Schematic Diagram.....
			5-17/5-18

SECTION 6-REPAIR

Figure		Page	Figure		Page
6-1	Discriminator Frequency Response Curves	6-8	6-4	Frequency Shift Converter CV-483C/URA-17, Right-Hand Terminal Board, Wiring Diagram	6-13/6-14
6-2	Filter and Transformer Resistance Data	6-9			
6-3	Frequency Shift Converter CV-483C/URA-17, Left-Hand Terminal Board, Wiring Diagram	6-11/6-12	6-5	Frequency Shift Converter CV-483C/URA-17, Overall Schematic Diagram	6-15/6-16

LIST OF TABLES

SECTION 1-GENERAL INFORMATION

Table		Page
1-1	Comparator-Converter Group AN/URA-17C, Equipment Supplied	1-4
1-2	Comparator-Converter Group AN/URA-17C, Equipment and Publications Required but not Supplied	1-5
1-3	Comparator-Converter Group AN/URA-17C, Test Equipment Required but not Supplied	1-6
1-4	Comparator-Converter Group AN/URA-17C, Shipping Data	1-7
1-5	Frequency Shift Converter CV-483C/URA-17, Transistor Complement	1-7
1-6	Frequency Shift Converter CV-483C/URA-17, Diode Complement	1-8

SECTION 2-INSTALLATION

2-1	Cabling Required for Single-Receiver Operation	2-5
2-2	Cabling of Each Converter for Diversity Operation	2-7
2-3	Frequency Shift Converter CV-483C/URA-17, CRT Adjustment controls	2-8

SECTION 3-OPERATOR'S SECTION

3-1	Frequency Shift Converter CV-483C/URA-17, Operating Controls	3-2
3-2	Operator's Check Chart	3-5
3-3	Comparator-Converter Group AN/URA-17C, Operator's Trouble-Shooting Chart	3-6

SECTION 5-TROUBLE-SHOOTING

Table		Page
5-1	Frequency Shift Converter CV-483C/URA-17, System Trouble-Shooting Chart	5-2
5-2	Frequency Shift Converter CV-483C/URA-17, Signal Processing Circuits Functional Section Trouble-Shooting Chart	5-5
5-3	Frequency Shift Converter CV-483C/URA-17, Keyer Circuits Function Section Troubl-Shooting Chart	5-8
5-4	Frequency Shift Converter CV-483C/URA-17, Power Supplies Functional Section Trouble-Shooting Chart	5-12
5-5	Signal Tracing Oscilloscope Patterns	5-6
5-6	Frequency Shift Converter CV-483C/URA-17, Typical Troubles	5-19

SECTION 6-REPAIR

6-1	Adjustments after Transistor Replacements	6-5
6-2	Filter Characteristics	6-5

SECTION 7-PARTS LIST

7-1	Comparator-Converter Group AN/URA-17C, Maintenance Parts List	7-1
7-2	Comparator-Converter Group AN/URA-17C, List of Manufacturers	7-15

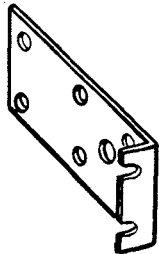
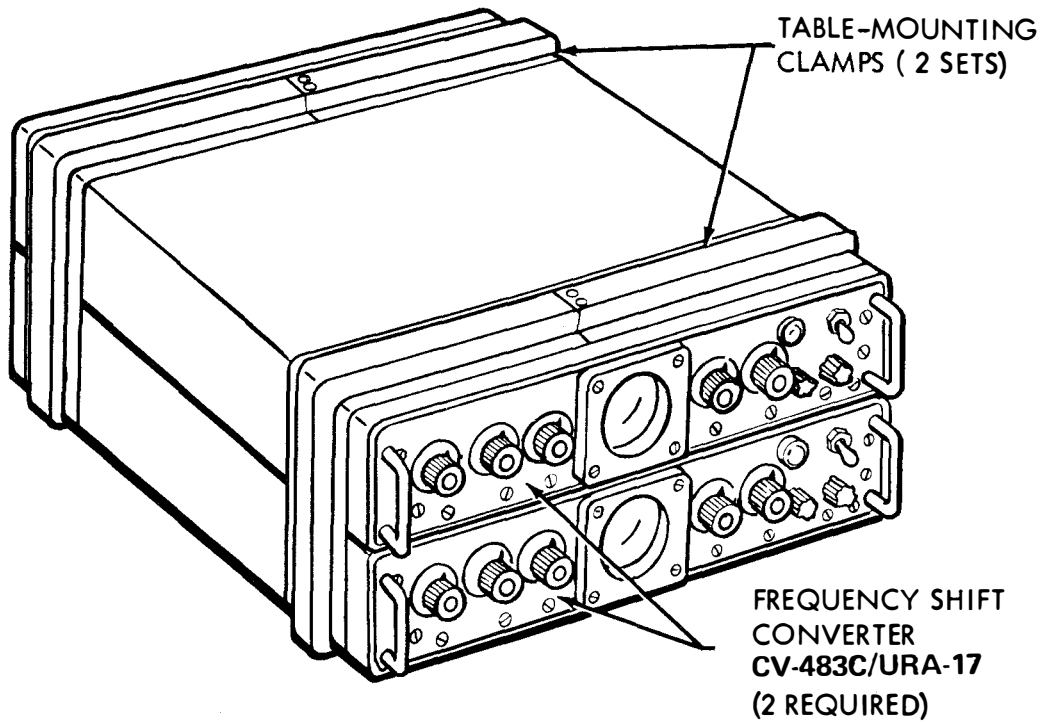

RACK-MOUNTING
BRACKETS (4)



UG-88D/U
CONNECTORS (6)

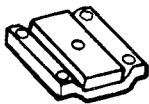
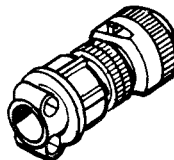

TABLE MOUNTING
FEET (4)



MS3106A14S-7P
CONNECTORS (2)
MS3106A14S-7S
CONNECTORS (2)
MS3106A14S-9S
CONNECTORS (2)

Figure 1-1. Comparator-Converter Group AN/URA-17C,
Equipment Supplied

SECTION 1 GENERAL INFORMATION

1-1. EQUIPMENT ILLUSTRATION.

Figure 1-1 illustrates Comparator-Converter Group AN/URA-17C, Federal Stock No. 2Z5820-042-7837, the equipment supplied under Contract NObsr 95389 and NObsr 95390.

1-2. FUNCTIONAL DESCRIPTION.

Comparator-Converter Group AN/URA-17C, hereinafter referred to as the AN/URA-17C, provides a link in the receiving end of a frequency-shift communication system. In this system, teletype mark-space characters are transmitted as rapid shifts above and below the center frequency of an rf carrier. These frequency-shift-keyed (fsk) signals are translated by a standard communications receiver into frequency variations about a center frequency of 1000 or 2000 cycles per second (cps). The AN/URA-17C changes these frequency-shifted audio signals into dc mark-space pulses for operation of a loop keying circuit of an automatic recording device. This method of communication provides the noise reduction advantages of frequency modulation for coded teletype messages at speeds to 400 words per minute.

The AN/URA-17C consists of two Frequency Shift Converters CV-483C/URA-17, hereinafter referred to as converters. Either converter may be operated in a single-receiver fsk receiving system or used together in combination with two receivers and a single teletype printer to provide a 'diversity' receiving system. The diversity system makes use of the principles of space-diversity or frequency-diversity reception to eliminate severe signal fading over long transmission distances.

In space-diversity operation, two receivers are tuned to the same rf carrier frequency but their receiving antennas are spaced several wavelengths apart. The advantage of this method of reception is that maximum fading of a given carrier frequency usually does not coincide in time at points so separated. The audio output of each receiver is applied to a separate converter.

In frequency-diversity operation, two receivers are tuned to different rf carrier frequencies, both containing the same mark-space modulation. The audio output of each receiver is applied to a separate converter. The advantage of this method of reception is that maximum fading of two different carrier frequencies seldom occurs at the same time in a given location. Two transmitting stations as well as two frequency channels are required. This method may be used when space limitations at the receiving site do not allow sufficient antenna separation for effective space-diversity operation.

During diversity operation, a comparator circuit in each converter continuously compares the two received signals, selecting the stronger signal for operation of the teletype printer. The teletype printer may be connected to either of the converters. When operating in a single-receiver system, the comparator circuits are inoperative.

1-3. DESCRIPTION OF THE MAJOR UNIT.

Each converter is installed in a navy gray aluminum cabinet. A handle is provided on each side of the front panel and at each end of the back panel. The cabinet is equipped with ball-bearing drawer slides which lock in the fully withdrawn position (figure 1-2). When fully withdrawn, all chassis terminals and connections are visible and easily accessible.

All external cables are attached to the converter by means of connectors which match receptacles on a removable panel at the rear of the cabinet. This panel is sloped 30 degrees to allow easy access to the cable receptacles. The cable receptacles at the rear of the cabinet are connected to the chassis by a single cable and connector. This cable is equipped with a retractor which keeps the cable in place.

A tuning indicator (two-inch cathode-ray tube) is located in the center of the front panel of each converter to allow a quick visual check of receiver tuning. The tuning indicator uses a 60 cps sweep voltage. An external indicator may be connected to a receptacle on the rear panel, for use when the operator cannot see the converter tuning indicator while tuning the receiver.

The converters each operate from a power source of 105, 115, or 125 volts, 50 to 400 cps, single phase ac. Except for the tuning indicator cathode-ray tube, only semiconductors are used.

Brackets and mounting bolts are supplied (figure 1-1) for installation of the converters in standard 19-inch racks. Feet for table-mounting a single converter and clamps for table-mounting two converters (one above the other) are also included.

1-4. FACTORY OR FIELD CHANGES.

No factory or field changes have been made at this date.

1-5. QUICK REFERENCE DATA.

a. AF INPUT SIGNAL. - Operates from 600 ohm line, with input signals of 60 microwatts to 60 milliwatts power.

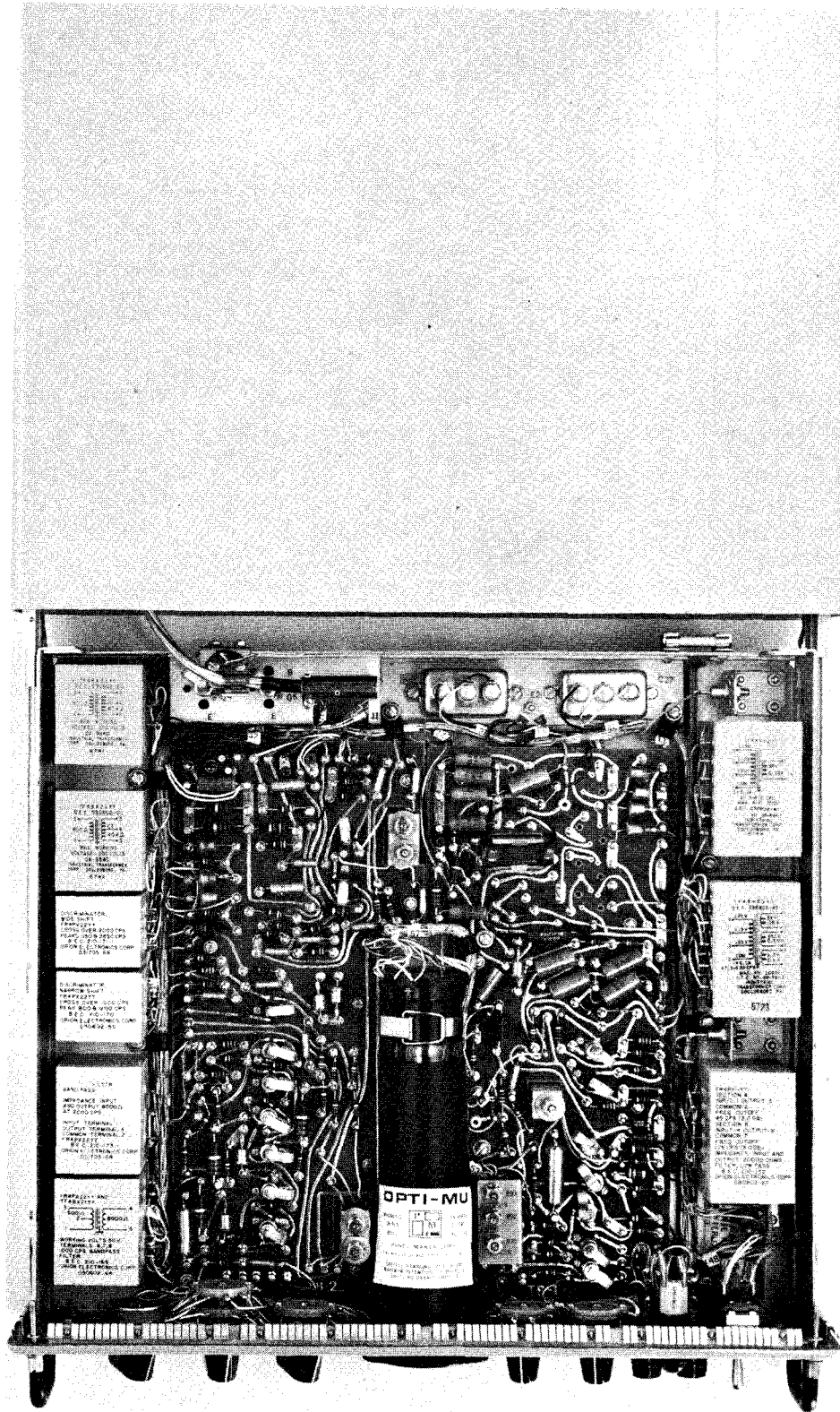

Figure 1-2. Frequency Shift Converter CV-483C/URA-17,
Top View, Chassis Fully Withdrawn

b. OPERATING FREQUENCIES. - Narrow shift 1000 cps mean frequency; width of shift, 10 to 200 cps. Wide shift, 2000 cps mean frequency; width of shift, 200 to 1000 cps.

c. MAXIMUM KEYING SPEEDS. - 100 words per minute, single channel; 400 words per minute, when used in four-channel, time-division multiplex with each channel operating at 100 words per minute.

d. OUTPUT. - Keys 60 ma current in teletype printer dc loop circuit.

e. POWER SOURCE REQUIREMENTS. - Frequency Shift Converter CV-483C/URA-17, 35 watts each, with source of 105 to 125 volts, 50 to 400 cps, single phase ac.

1-6. EQUIPMENT LISTS.

a. EQUIPMENT SUPPLIES. - Table 1-1 lists equipment supplied.

b. EQUIPMENT AND PUBLICATIONS REQUIRED BUT NOT SUPPLIED. - Table 1-2 lists equipment and publications required but not supplied.

c. TEST EQUIPMENT REQUIRED BUT NOT SUPPLIED. - Table 1-3 lists test equipment required but not supplied.

d. SHIPPING DATA. - Table 1-4 provides information covering the complete equipment as packed for shipment.

e. EQUIPMENT SIMILARITIES. - Comparator-Converter Group AN/URA-17C performs functions similar to those of Comparator-Converter Group AN/URA-8 and AN/URA-17. The AN/URA-17 through AN/URA-17C use semiconductors rather than vacuum tubes. The AN/URA-17 and AN/URA-17C are not electrically or mechanically interchangeable with the AN/URA-8.

f. TRANSISTOR AND DIODE COMPLEMENT. - Tables 1-5 and 1-6 list the transistor and diode complement.

TABLE 1-1. COMPARATOR-CONVERTER GROUP AN/URA-17C
EQUIPMENT SUPPLIED

QUANT. PER EQUIP.	NOMENCLATURE		*OVERALL DIMENSIONS			*VOLUME	*WEIGHT
	NAME	DESIGNATION	HEIGHT	WIDTH	DEPTH		
2	Frequency Shift Converter	CV-483C/URA-17	3-15/32	16-11/16	18-7/8	0.63	26
2	Clamps for table-mounting AN/URA-17C		8	17-11/16	3-3/4	0.08	1.5
8	Feet for table-mounting Frequency Shift Converter CV-483C/URA-17		1/4	2-3/8	2-3/8	0.005	0.12
4	Bracket for rack-mounting Frequency Shift Converter CV-483C/URA-17		3-15/32	1-5/32	8	0.007	0.75
6	Cable connector	UG-88D/U					
2	Cable connector	MS3106A14S-7S					
2	Cable connector	MS3106A14S-7P					
2	Cable connector	MS3106A14S-9S					
6	Clamp, Cable	AN3057-6					
2	Technical manual	NAVSHIPS					

* Unless otherwise stated, dimensions are in inches, volume in cubic feet, weight in pounds.

TABLE 1-2. COMPARATOR-CONVERTER GROUP AN/URA-17C, EQUIPMENT AND PUBLICATIONS REQUIRED BUT NOT SUPPLIED

QUANT. PER EQUIP.	NOMENCLATURE		REQUIRED USE	REQUIRED CHARACTERISTICS
	NAME	DESIGNATION		
2	Standard navy radio receiver	RBA, RBB, RBC, SRR-11, SRR-12, SRR-13, WRR-2, WRR-3 or equivalent	To receive frequency-shifted rf signals and deliver frequency-shifted af signals to input of Comparator-Converter Group AN/URA-17C	Frequency- shifted af output of 600 ohms impedance, and up to 60 milliwatts power.
-	Technical manual for each receiver used.	--	For operating instructions.	---
4	Mounting bolts	--	For table-mounting the AN/URA-17C	1/4-28 thread x mounting surface thickness + 3/8 inch long.
-	Interconnecting cables	MCOS-2 TTHFWA-1-1/2 TTHFWA-1-1/2 RG-58A/U RG-58A/U	Connect source power to POWER connector (J3). Connect teletype printer to TTY OUTPUT connector (J6). Connect audio input to AUDIO INPUT connector (J2). Connect remote indicator (if used) to REMOTE TUNING IND connector (J7). Connect DIV. A connector (J4) of each converter to the DIV. B connector (J5) of the other converter.	---
1	Teletype printer, or other automatic recorder	--	To record messages represented by the keyed output of the AN/URA-17C	Keying loop current of 60 ma, dc.

TABLE 1-3. COMPARATOR-CONVERTER GROUP AN/URA-17C, TEST EQUIPMENT
REQUIRED BUT NOT SUPPLIED

QUANT. PER EQUIP.	NOMENCLATURE		REQUIRED USE	REQUIRED CHARACTERISTICS
	NAME	DESIGNATION		
1	Oscilloscope	DuMont 304-A	Trouble-shooting the AN/URA-17C	Display 800 to 3600 cps audio frequency signals at amplitude of 0.1 to 50.0 volts.
2	Vtvm, ac	ME-30/U	Trouble-shooting and alignment of converters; checking filters and discriminators.	Measure audio frequency voltages, 0.1 to 20 volts at 800 to 3600 cps, ±5%.
1	Audio oscillator	TS-382A/U	Alignment of converters; checking filters and discriminators.	Audio frequency output: 800 to 3600 cps at amplitudes 0 to 10 volts.
1	Frequency meter	AN/TSM-9	Checking filters and discriminators.	Measurement of audio frequencies, ±1%.
2	Multimeter	AN/PSM-4	Trouble-shooting, measurement of power supply outputs, alignment, checking filters and discriminators.	DC voltages 0 to 560 volts ±3%, ac voltages 0 to 125 volts ±5%, at 50 to 400 cps.
1	Test set, transistor	TS-1100/U	Test transistors and diodes.	Test semiconductors (in circuit or out).

TABLE 1-4. COMPARATOR-CONVERTER GROUP AN/URA-17C, SHIPPING DATA

BOX NO.	NOMENCLATURE		*OVERALL DIMENSIONS			*VOLUME	*WEIGHT
	NAME	DESIGNATION	HEIGHT	WIDTH	DEPTH		
1	Comparator-Converter Group	AN/URA-17C	16-3/4	26-3/4	24-3/4	6.42	125

* Unless otherwise stated, dimensions are in inches, volume in cubic feet, and weight in pounds; equipment crated and ready for shipment.

TABLE 1-5. FREQUENCY SHIFT CONVERTER CV-483C/URA-17C,*
TRANSISTOR COMPLEMENT

SYMBOL	NUMBER OF TRANSISTORS OF TYPES INDICATED							TOTAL
	2N328A	2N333	2N336	2N497	2N526	2N657	2N1041	
Q1					1			1
Q2					1			1
Q3					1			1
Q4							1	1
Q5							1	1
Q6		1						1
Q7		1						1
Q8		1						1
Q9		1						1
Q10						1		1
Q11			1					1
Q12				1				1
Q13		1						1
Q14	1							1
Q15	1							1
Q16		1						1
Q17						1		1
Q18						1		1
Total Number of each Type	2	6	1	1	3	3	2	18

*The AN/URA-17C complement is twice the above.

TABLE 1-6. FREQUENCY SHIFT CONVERTER CV-483C/URA-17.*
DIODE COMPLEMENT

SYMBOL	NUMBER OF DIODES OF TYPES INDICATED							TOTAL
	1N457	1N538	1N1731	1N2995B	1N2995BR	1N3025B	1N3042B	
CR1		1						1
CR2		1						1
CR3		1						1
CR4		1						1
CR5		1						1
CR6		1						1
CR7						1		1
CR8						1		1
CR9		1						1
CR10		1						1
CR11	1							1
CR12	1							1
CR13	1							1
CR14	1							1
CR15	1							1
CR16	1							1
CR17	1							1
CR18		1						1
CR19	1							1
CR20		1						1
CR21							1	1
CR22							1	1
CR23		1						1
CR24		1						1
CR25		1						1
CR26		1						1
CR27				1				1
CR32			1					1
CR34					1			1
Total Number of Each Type	8	14	1	1	1	2	2	29

*The AN/URA-17C complement is twice the above.

SECTION 2 INSTALLATION

2-1. UNPACKING AND HANDLING

Comparator-Converter Group AN/URA-17C (hereinafter referred to as the AN/URA-17C) and accessories are packed in one corrugated fiber shipping container. The equipment is packaged in a corrugated fiberboard carton inside a moisture-vaporproof wrapper with a desiccant included. Do not unpack until ready for use.

Place shipping box in right-side-up position, cut fiberglass tapes. Open the outer fiberboard carton and the barrier bag. Open the inner carton and remove the equipment.

CAUTION

Do not cut the inner carton open unless the cutting blade has a guard which will prevent cutting deeper than the thickness of the fiberboard.

Remove the accessories from the packing cells and check the equipment for shipping damage, and against the list of equipment supplied, table 1-1.

2-2. POWER REQUIREMENTS AND DISTRIBUTION.

The AN/URA-17C consists of two Frequency Shift Converters CV-483C/URA-17. Each Frequency Shift Converter CV-483C/URA-17 (hereinafter referred to as the converter) requires 35 watts of input power and is internally wired for operation on 115 volts, 50 to 400 cps, single phase ac. If 105 or 125 volt line voltage is to be used, the connections to power transformers T3 and T4 (figure 5-1) will require changing (refer to paragraph 2-4c(4)). Figure 5-9 shows the primary power distribution for the converter.

2-3. INSTALLATION LAYOUT.

Install the AN/URA-17C so the tuning indicators may be observed while tuning the associated receivers. If this is not feasible, any oscilloscope with a dc vertical amplifier may be used as a remote tuning indicator, located near the receivers. It is desirable to install the two converters together if used for diversity operation. Converters used for single-receiver operation should be located near their respective receivers. The installation layout should also allow sufficient space in front of the converters to permit withdrawal of the chassis for servicing (refer to paragraph 2-4a).

2-4. INSTALLATION REQUIREMENTS.

a. OUTLINE DRAWINGS. - Figure 2-1 shows all mounting dimensions and clearances required for table-mounting the AN/URA-17C. Figure 2-2 shows all mounting

dimensions and clearances required for table-mounting the CV-483C/URA-17. Figure 2-3 shows all mounting dimensions and clearances required for rack-mounting the CV-483C/URA-17.

b. EQUIPMENT MOUNTING. - The AN/URA-17C may be table-mounted, or the clamps removed and the individual converters separately table or rack-mounted. Refer to applicable mounting procedure in the following paragraphs.

(1) TABLE-MOUNTING THE AN/URA-17C. - Table-mounting of the AN/URA-17C is performed as follows

- Step 1. Layout and drill four 9/32 inch holes (figure 2-1) through mounting surface.
- Step 2. Place AN/URA-17C in position on mounting surface.
- Step 3. Insert four bolts (1/4-28 thread x mounting surface thickness + 3/8 inch long) up through mounting surface into captive nuts in AN/URA-17C. Tighten securely.

(2) TABLE-MOUNTING THE CV-483C/URA-17. - Table-mounting of the CV-483C/URA-17 is performed as follows

- Step 1. Layout and drill four 9/32 inch holes (figure 2-2) through mounting surface.
- Step 2. Install mounting feet on bottom of cabinet, using 8-32 binder-head screws and washers provided.
- Step 3. Remove chassis from cabinet (Section 6, paragraph 6-3c(1)).
- Step 4. Insert four socket-head cap screws (1/4-20 thread) through holes in bottom of cabinet (of sufficient length to pass through mounting surface and allow use of flat washer and lock-washer under each nut).
- Step 5. Install flat washer, lockwasher, and nut on each bolt and tighten securely.
- Step 6. Replace chassis in cabinet.

(3) RACK-MOUNTING THE AN/URA-17C. - Rack-mounting of the AN/URA-17C is performed as follows

- Step 1. Remove clamps holding converters together, and lift off upper converter.

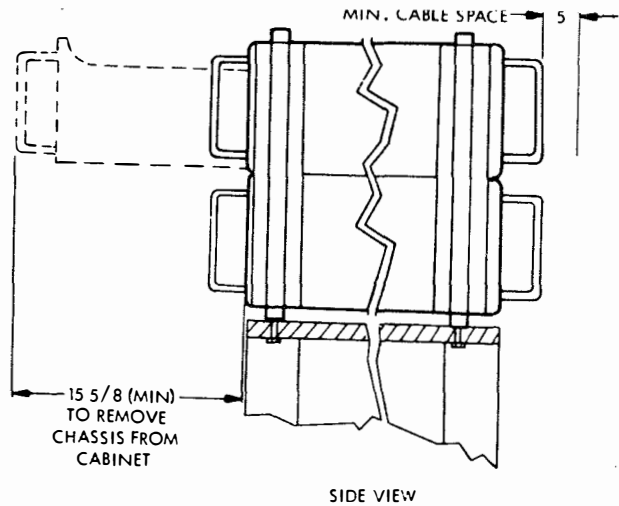
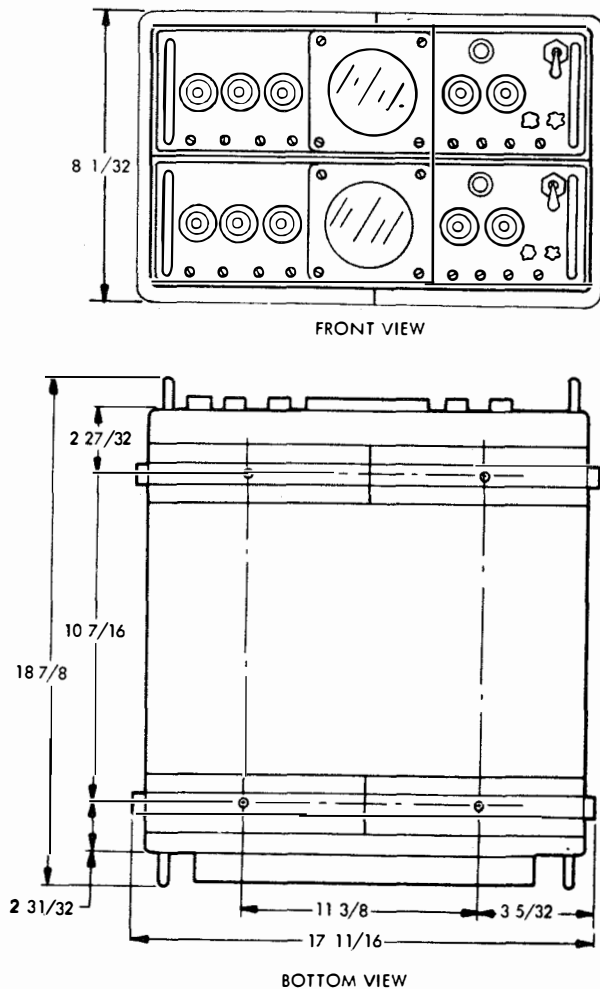

NOTE: ALL DIMENSIONS ARE IN INCHES

Figure 2-1. Comparator-Converter Group AN/URA-17C, Table-Mounting Installation Drawing

- Step 2. Remove 10-32 binder-head screws (six on side of each cabinet, figure 2-3).
- Step 3. Fasten rack-mounting brackets on each cabinet, using screws just removed (figure 2-3). Tighten screws securely.
- Step 4. Remove chassis from each cabinet (Section 6, paragraph 6-3c(1)).
- Step 5. Install cabinets in rack. Bolt securely.
- Step 6. Replace chassis in cabinets.

- Step 3. Remove chassis from cabinet (Section 6, paragraph 6-3c(1)).
- Step 4. Install cabinet in rack. Bolt securely.
- Step 5. Replace chassis in cabinet.

(4) RACK-MOUNTING THE CV-483C/URA-17.
Rack-mounting of the CV-483C/URA-17 is performed as follows:

- Step 1. Remove 10-32 binder-head screws (six on each side of cabinet, figure 2-3).
- Step 2. Fasten rack-mounting brackets on cabinet, using screws just removed (figure 2-3). Tighten screws securely.

c. INTERCONNECTION. - All interconnecting cables attach to receptacles on the rear of the converter cabinets. These cables must be fabricated during installation, in lengths determined by equipment layout. Instructions for attaching the supplied connectors to the required cables are given in paragraph 2-4d.

NOTE

Interconnecting cable types may vary between installations. Refer to applicable ship or station plans to determine the correct cabling for the specific installation.

(1) **INTERCONNECTING CABLES FOR SINGLE-RECEIVER OPERATION.** - Table 2-1 lists the required cable and connector information for single-receiver operation of one converter. Figure 2-4 illustrates the interconnection to associated equipment.

(2) **INTERCONNECTING CABLES FOR DIVERSITY OPERATION.** - Table 2-2 lists the required cable and connector information for diversity operation of the AN/URA-17C. Figure 2-5 illustrates the interconnection to associated equipment.

(3) **AUDIO INPUT LINES.** - The AN/URA-17C requires 600 ohm, 60 milliwatt outputs from the associated receivers. If the receiver outputs are balanced, STANDOFF

E1 in each converter should be grounded. To accomplish this, loosen the four captive screws at corners of receptacle panel, remove panel from the rear of each converter cabinet (figure 2-6), and solder a lead from STANDOFF E1 to a nearby ground terminal. If the receiver outputs are unbalanced (one side grounded), leave STANDOFF E1 ungrounded.

(4) **POWER TRANSFORMER CONNECTIONS.** The AN/URA-17C is shipped from the factory with power transformers T3 and T4 in each converter connected for a nominal line voltage of 115 volts. If nominal line voltage is 105 volts, the leads connected to terminal 3 of T3 and T4 (see Section 5, figure 5-1) must be moved to terminal 2 of the respective transformer. If nominal line voltage

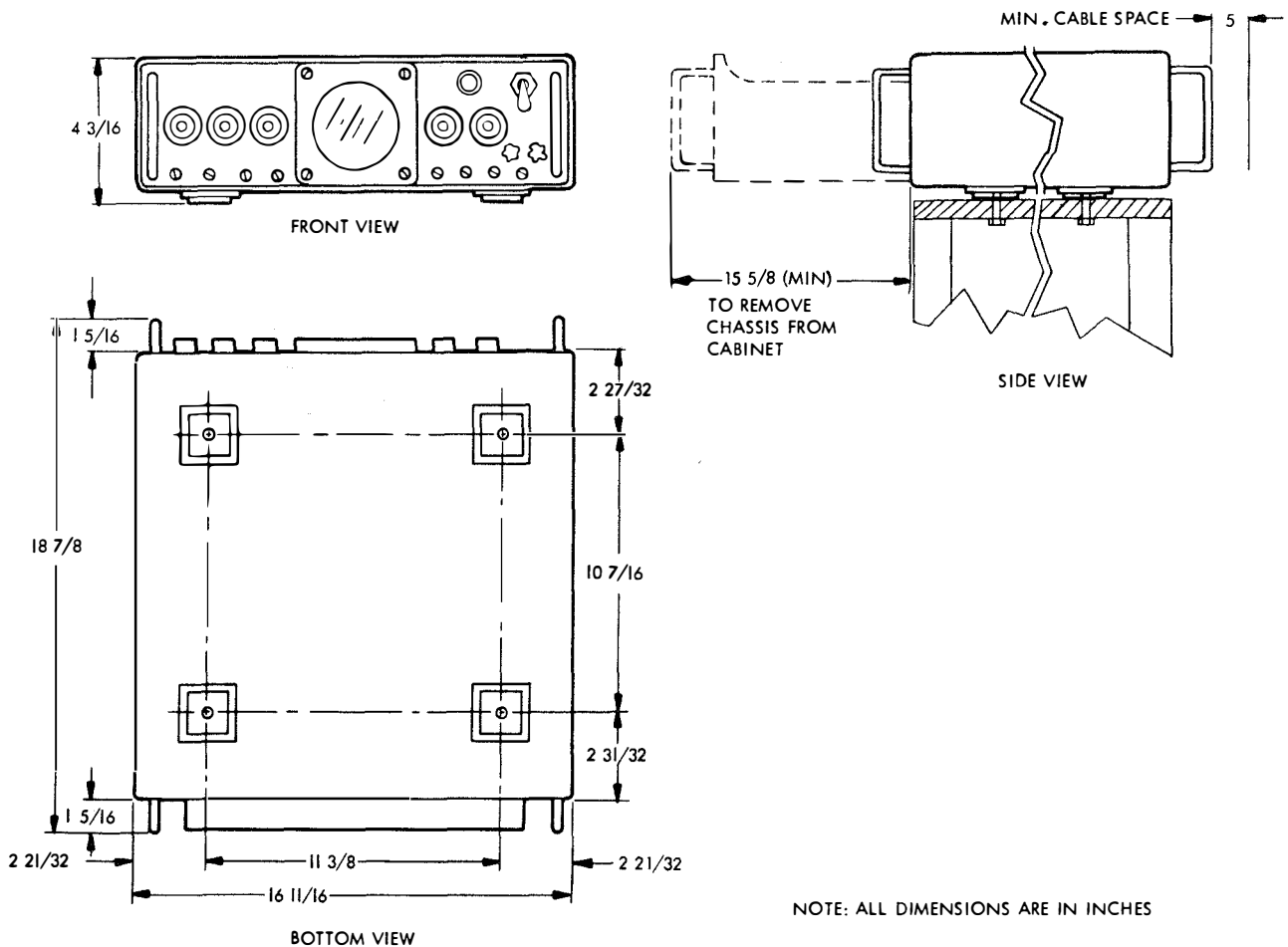

Figure 2-2. Frequency Shift Converter CV-483C/URA-17, Table-Mounting Installation Drawing

is 125 volts, the leads connected to terminal 3 to T3 and T4 must be moved to terminal 4 of the respective transformer.

d. CABLE ASSEMBLY. - Attach the connectors to interconnecting cables as follows

(1) ATTACHING UG-88D/U CONNECTORS TO RG-58A/U COAXIAL CABLE. - Attach the UG-88D/U connectors (supplied) to RG-58A/U coaxial cable as described in figure 2-7.

(2) ATTACHING MS CONNECTOR TO MCOS-2 CABLE. - Attach each MS connector (supplied) to MCOS-2 cable as described below (see figure 2-8).

Step 1. Cut cable and even.

Step 2. Slide cable clamp (1), rubber washer (2), soldering ring (3), and extension (4) over end of cable, in order given.

Step 3. Remove vinyl jacket from 1/16 inch of cable.

Step 4. Unbraid and pigtail braid.

Step 5. Remove insulation from 3/16 inch of leads.

Step 6. Tin bare lead ends.

Step 7. Slide a 1/2 inch length of vinyl tubing over end of each lead.

Step 8. Solder each lead to plug pin, according to table 2-1 or 2-2, as applicable.

Step 9. Slide vinyl tubing on each lead so it covers soldered connection. Wrap a layer of adhesive plastic tape around leads.

Step 10. Slide extension (4) over pigtail and screw it on shell (5).

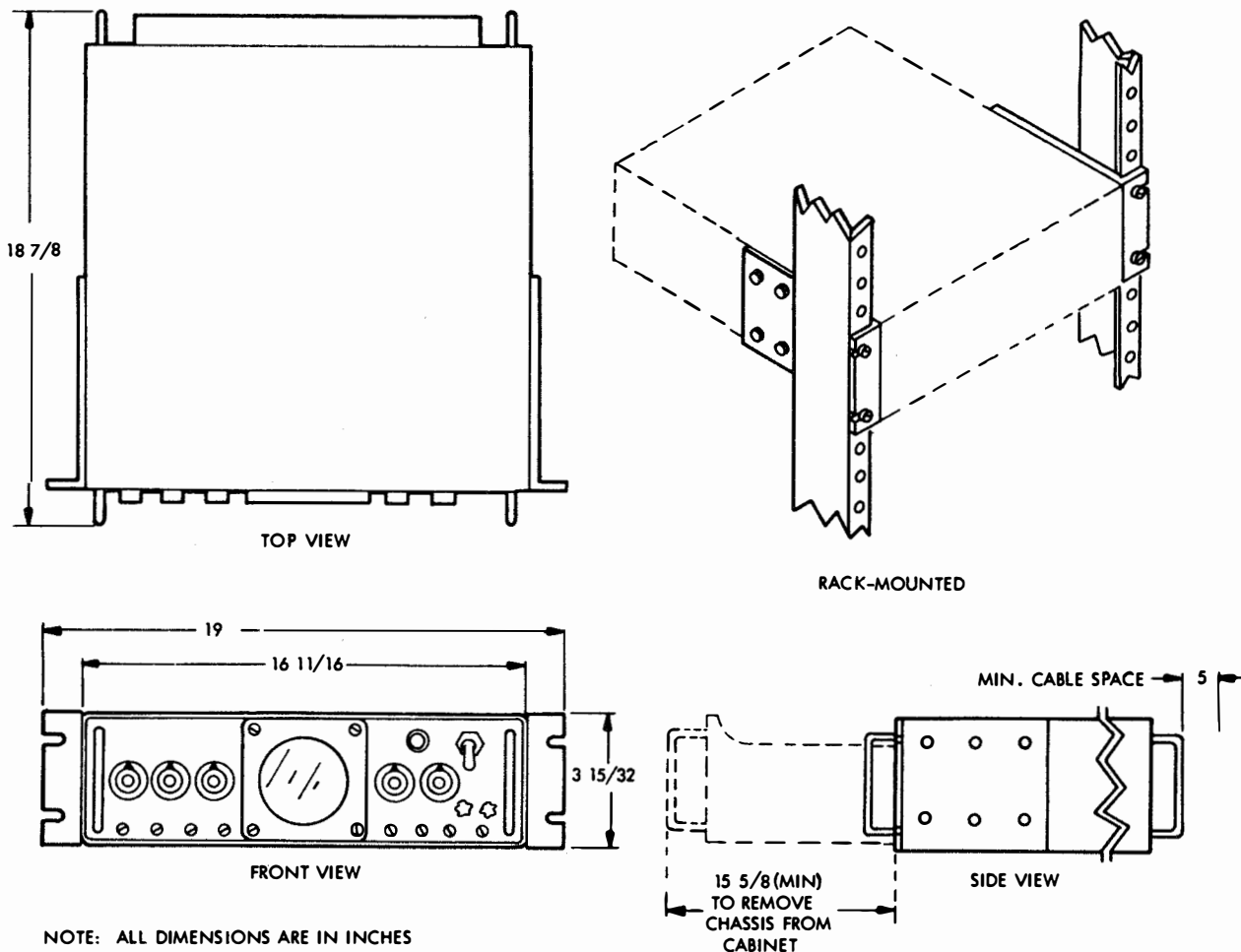

Figure 2-3. Frequency Shift Converter CV-483C/URA-17, Rack-Mounting Installation Drawing

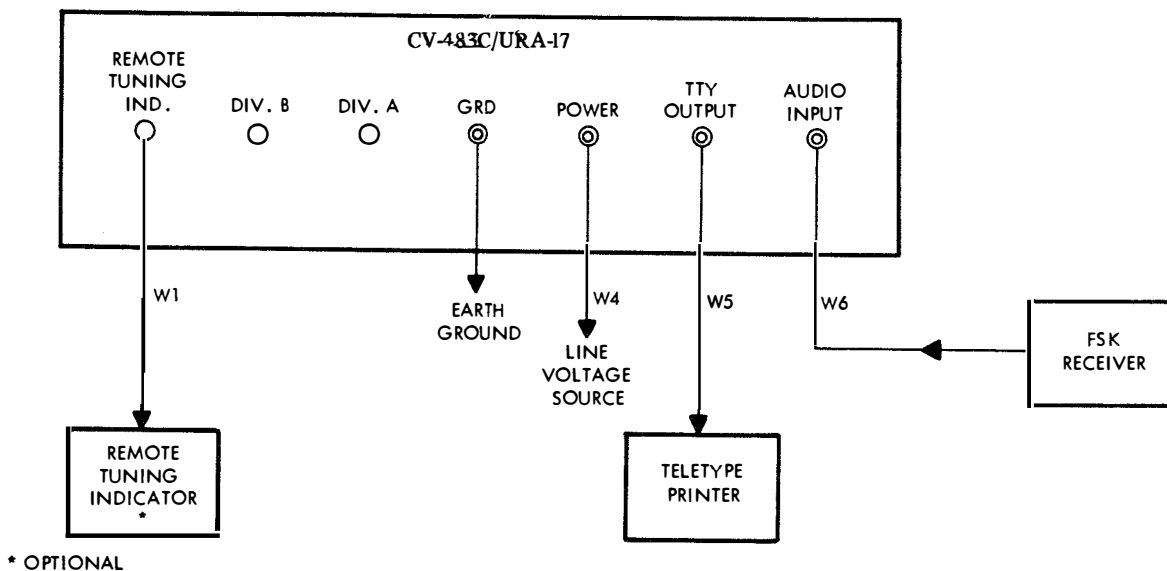

Figure 2-4. Frequency Shift Converter CV-483C/URA-17,
Interconnecting Data for Single-Receiver Operation

TABLE 2-1. CABLING REQUIRED FOR SINGLE-RECEIVER OPERATION*

CABLE TYPE	PLUG		CONNECTIONS		TERMINATIONS	
	SYMBOL	DESIGNATION	LEAD COLOR	PIN NO.	FROM	TO
TTHFWA-1-1/2 (W6)	P202	MS3106A14S-7P	BLACK WHITE RED	A B SPARE	AUDIO INPUT connector J2	FSK receiver
MCOS-2 (W4)	P203	MS3106A14S-7S	BLACK WHITE	A B (GRD)	POWER INPUT connector J3	Line voltage source
TTHFWA-1-1/2 (W5)	P206	MS3106A14S-9S	BLACK WHITE RED	B (GRD) A (HOT) SPARE	TTY OUTPUT connector J6	Teletype printer keying loop
RG-58A/U (W1)**	P207	UG-88D/U	---	---	REMOTE TUNING IND. connector J7	Remote tuning indicator
Copper strap (solid)	---	---	---	---	GRD terminal	Good earth ground

* Use in conjunction with figure 2-4.

** Required only when remote tuning indicator is used.

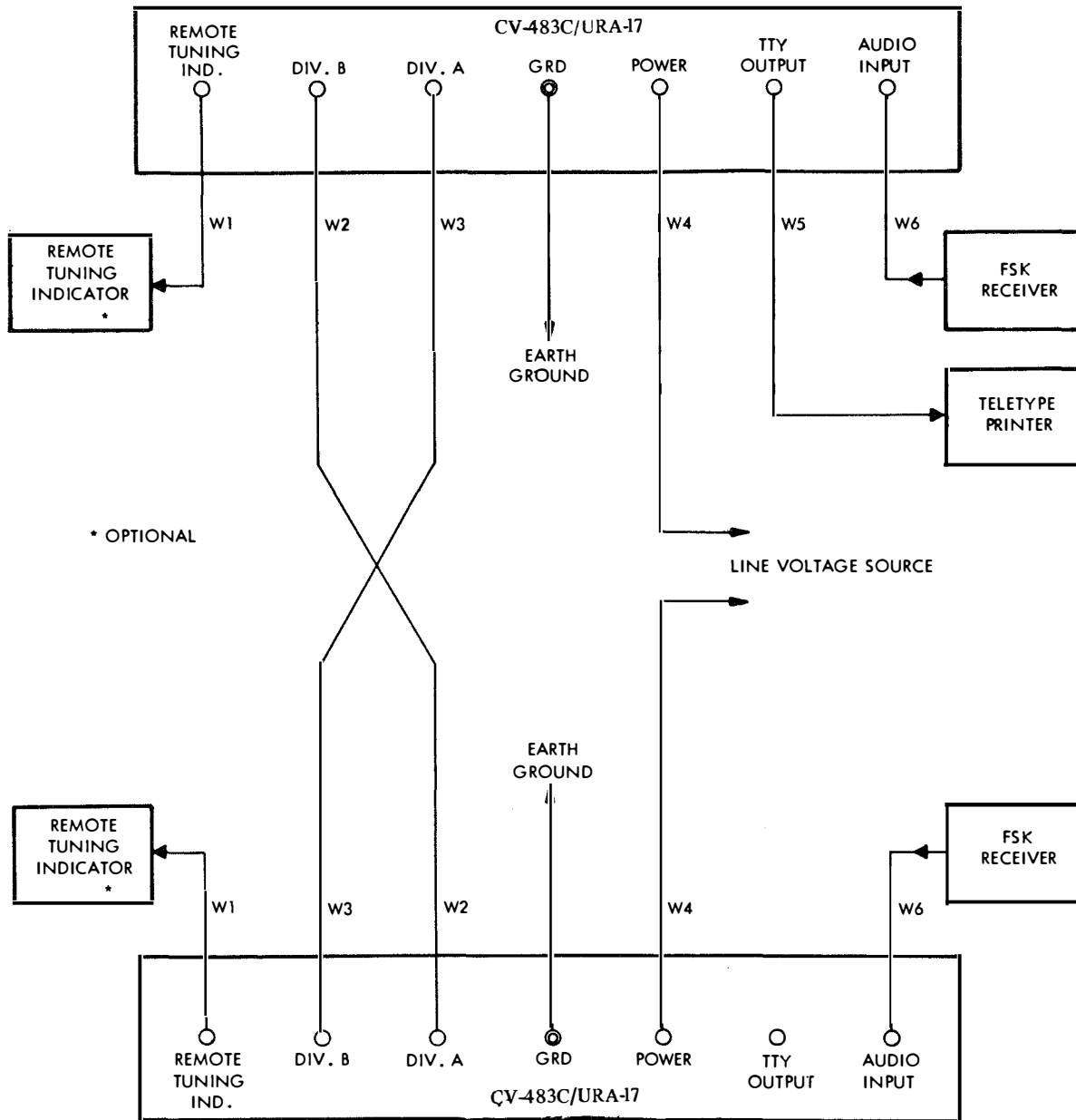

Figure 2-5. Comparator-Converter Group AN/URA-17C,
Interconnecting Data for Diversity Operation

- | | | |
|----------|---|---|
| Step 11. | Solder pigtail to soldering ring (3). | (exposing 1/16 inch end of cable). |
| Step 12. | Screw cable clamp (1) on extension and tighten cable clamp screws. | Step 3. |
| | (3) ATTACHING MS CONNECTORS TO TTHFWA-1-1/2 CABLE. - Attach each MS connector (supplied) to TTHFWA-1-1/2 cable as described below (see figure 2-9): | Slide cable clamp (1), rubber washer (2), soldering ring (3), and extension (4) over end of cable in order given. |
| Step 1. | Cut cable end even.. | Step 4. |
| Step 2. | Wrap layer of adhesive plastic tape around armor | Remove armor, vinyl jacket, and wrappings from 1/16 inch of cable. |
| | | Step 5. |
| | | Remove insulation from 3/16 inch of leads to be used. Do not remove insulation from |

TABLE 2-2. CABLING OF EACH CONVERTER FOR DIVERSITY OPERATION*

CABLE TYPE	PLUG		CONNECTIONS		TERMINATIONS	
	SYMBOL	DESIGNATION	LEAD COLOR	PIN NO.	FROM	TO
TTHFWA-1-1/2 (W6)	P202	MS3106A14S-7P	BLACK WHITE RED	A B SPARE	AUDIO INPUT connector J2	FSK receiver
MCOS-2 (W4)	P203	MS3106A14S-7S	BLACK WHITE	A B (GRD)	POWER input connector J3	Line voltage source
TTHFWA-1-1/2 (W5)**	P206	MS3106A14S-9S	BLACK WHITE RED	B (GRD) A (HOT) SPARE	TTY OUTPUT connector J6	Teletype printer keying loop
RG-58A/U (W3)**	P204	UG-83D/U	---	---	DIV. A connector J4	DIV. B, on other converter
RG-58A/U (W2)**	P205	UG-88D/U	---	---	DIV. B connector J5	DIV. A, on other converter
RG-58A/U (W1)***	P207	UG-88D/U	---	---	REMOTE TUNING IND. J7 connector	Remote tuning indicator
Copper strap (solid)	---	---	---	---	GRD terminal	Good earth ground

* Use in conjunction with figure 2-5.

** These cables required only for one converter.

*** Required only when remote tuning indicator is used.

'spare' lead.

shell (5).

Step 6. Tin bare lead ends.

Step 11. Screw cable clamp (1) on extension and tighten cable clamp screws.

Step 7. Slide a 1/2 inch length of vinyl tubing over end of each lead to be used. Slide a 1/16 inch length of vinyl tubing over end of spare lead.

2-5. INSPECTION AND ADJUSTMENTS.

Step 8. Solder each lead to plug pin, according to table 2-1 or 2-2, as applicable.

a. MECHANICAL AND ELECTRICAL CHECKS. Before releasing the AN/URA-17C to operating personnel, perform the following mechanical and electrical checks:

Step 9. Slide vinyl tubing on each lead so it covers soldered connection. Wrap a layer of adhesive plastic tape around leads.

(1) MECHANICAL CHECKS. - Check each control for smoothness of operation. Check chassis drawer slides and lubricate lightly with lubriplate, if required.

Step 10. Slide extension (4) over pigtail and screw it on

(2) ELECTRICAL CHECKS.

TABLE 2-3. FREQUENCY SHIFT CONVERTER CV-483C/URA-17,
CRT ADJUSTMENT CONTROLS

CONTROL	FUNCTION
FOCUS	Used to sharpen the lines in the cathode-ray tube display.
INTENSITY	Used to adjust the intensity of the cathode-ray tube display.
VERT CTR	Used to center the cathode-ray tube display (with no signal input).

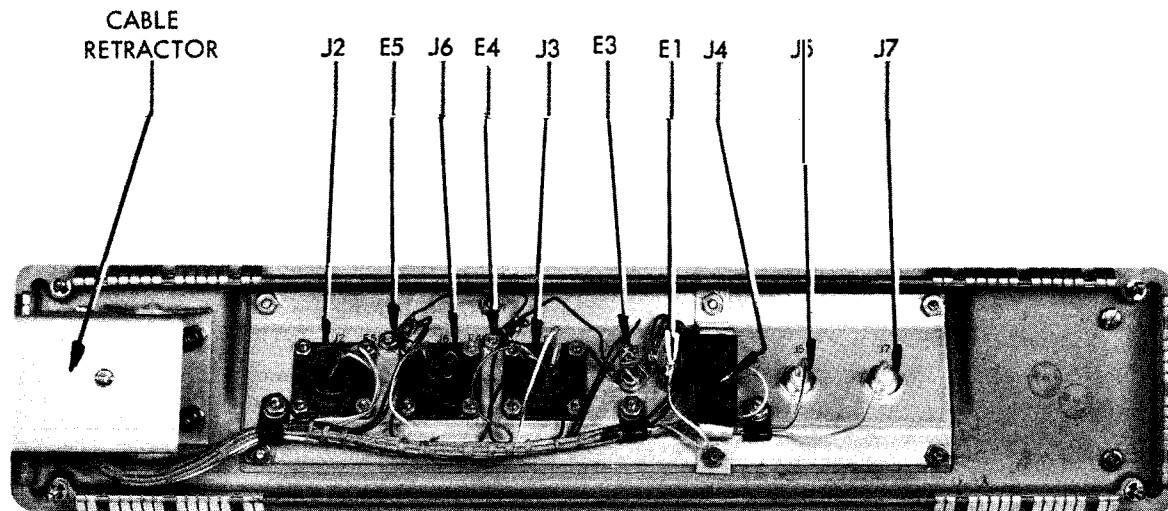

Figure 2-6. Frequency Shift Converter CV-483C/URA-17, Cable Receptacle Panel, Interior View

(a) CRT ADJUSTMENT CONTROLS. (Table 2-3.) - Turn POWER switch of one converter to On and set the FUNCTION switch to TUNE. With no signal input to converter, horizontal trace on tuning indicator should coincide with center line of crt bezel and be bright and sharp. If not, proceed as follows:

- Step 1. Loosen captive screw at each corner of front panel.
- Step 2. Pull chassis forward until controls (figure 2-10) are accessible.
- Step 3. Operate interlock switch (figure 2-10) by pressing in on button at left side of switch.
- Step 4. Adjust FOCUS, INTENSITY, and VERT CRT controls as required, push chassis back into cabinet, and tighten captive screws.
- Step 5. Repeat for second converter.

(b) PRE-OPERATIONAL CHECK. - Interconnect the converter and teletype printer as illustrated in figure 2-11. Turn teletype printer dc loop current supply on. Check teletype printer dc loop voltage and polarity. It should be approximately 12 volts, positive with respect to chassis, at terminal A of TTY OUTPUT receptacle (J6) on rear of converter to which teletype printer is connected. Adjust teletype printer dc loop current for 60 milliampere indication on TTY panel ammeter by means of applicable rheostat.

(c) OPERATIONAL CHECK. - Upon completion of pre-operational checks, check equipment for proper operation as described in Section 3, paragraph 3-2g(1) for single-receiver operation or in Section 3, paragraph 3-2g(2) for diversity operation. Check with both narrow-shift and wide-shift signals, if practicable. If operation is not correct, recheck all steps of installation. If

difficulty cannot be found and corrected, notify communications officer at station or ship.

NOTE

Unmodified R390-A radio receivers have insufficient audio output to operate this equipment efficiently. The required modification is Field Change 2-8-390A/URR (Electronics Information Bulletin 542, dated 22 August 1960). After modification, set Line Meter switch to +10 position and adjust Line Gain control for +10 indication on Line Level meter.

2-6 PREPARATION FOR RESHIPMENT.

a. INTERCONNECTING CABLES. Disconnect all cables from the receptacles on rear of converters. Remove all connectors from cable ends at converter, for use at next installation.

b. DISMOUNTING EQUIPMENT. - If table-mounted, remove the converter chassis from cabinet (as described in Section 6, paragraph 6-3c(1)), and take out bolts holding cabinet to mounting surface. If rack-mounted, remove converter from rack and take off mounting brackets. Replace bolts removed from converter cabinet.

c. PACKING. - Before packing for shipment, check all items against table 1-1. Instruct packaging and packing facility as to type of equipment and whether the preparation shall be for domestic shipment-immediate use, domestic shipment and storage, or for overseas shipment; and to mark the box containing the technical manuals, 'TECHNICAL MANUALS INSIDE.'

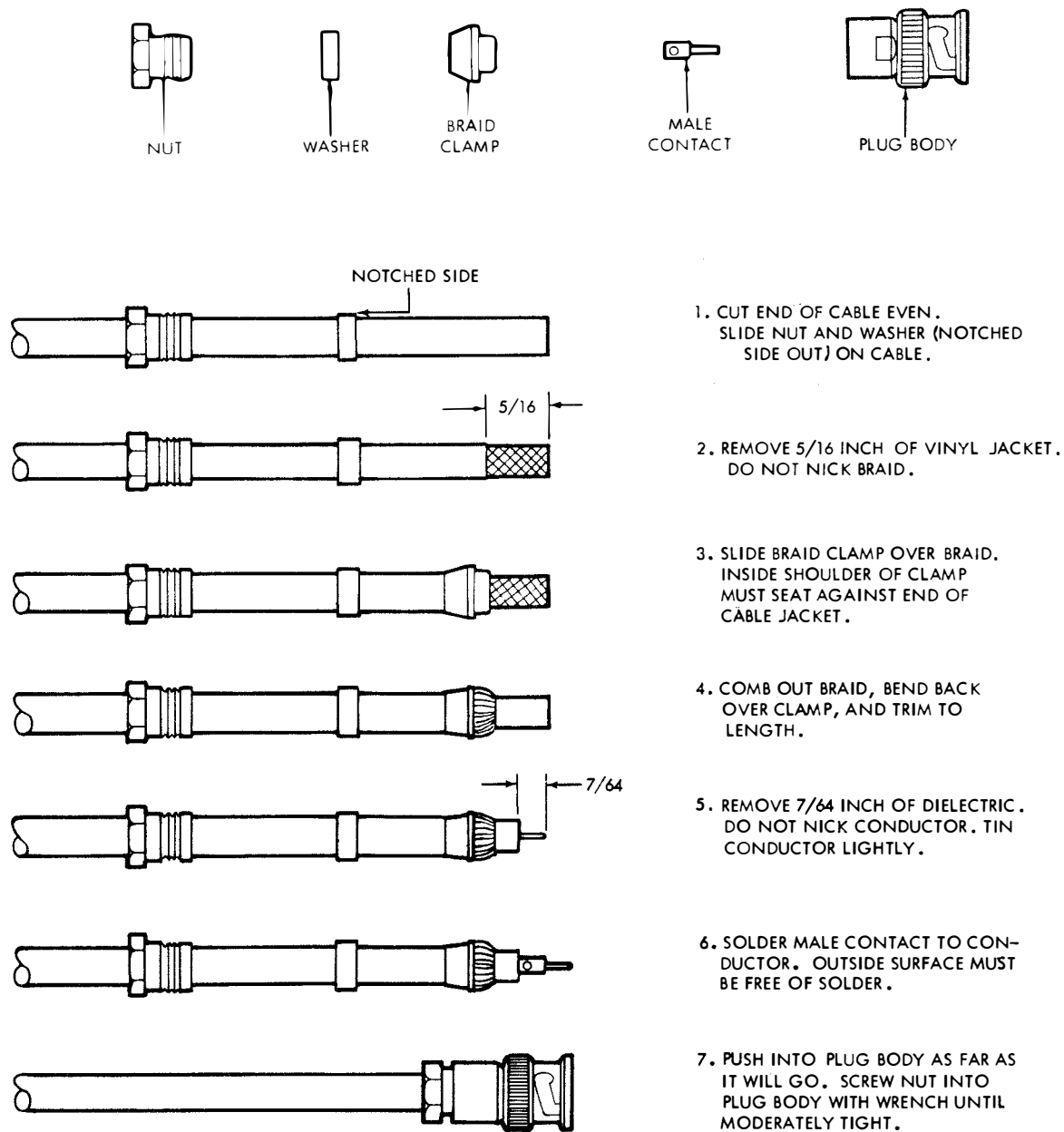

NOTE: ALL DIMENSIONS ARE IN INCHES

Figure 2-7. Attaching UG-88D/U Plug to RG-58A/U Coaxial Cable

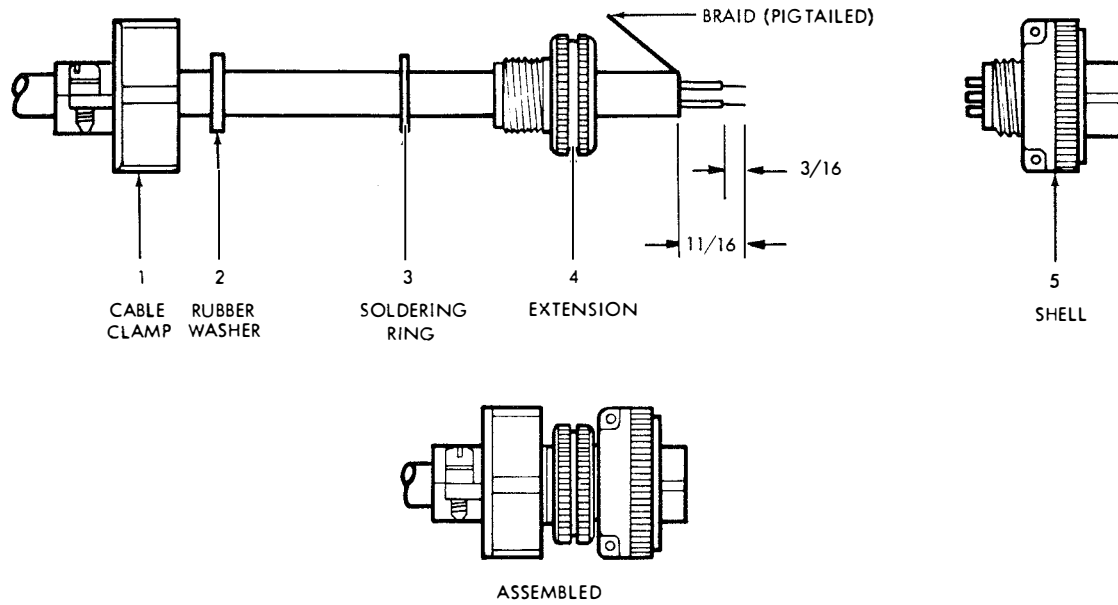

Figure 2-8. Attaching MS Plug to MCOS-2 Cable

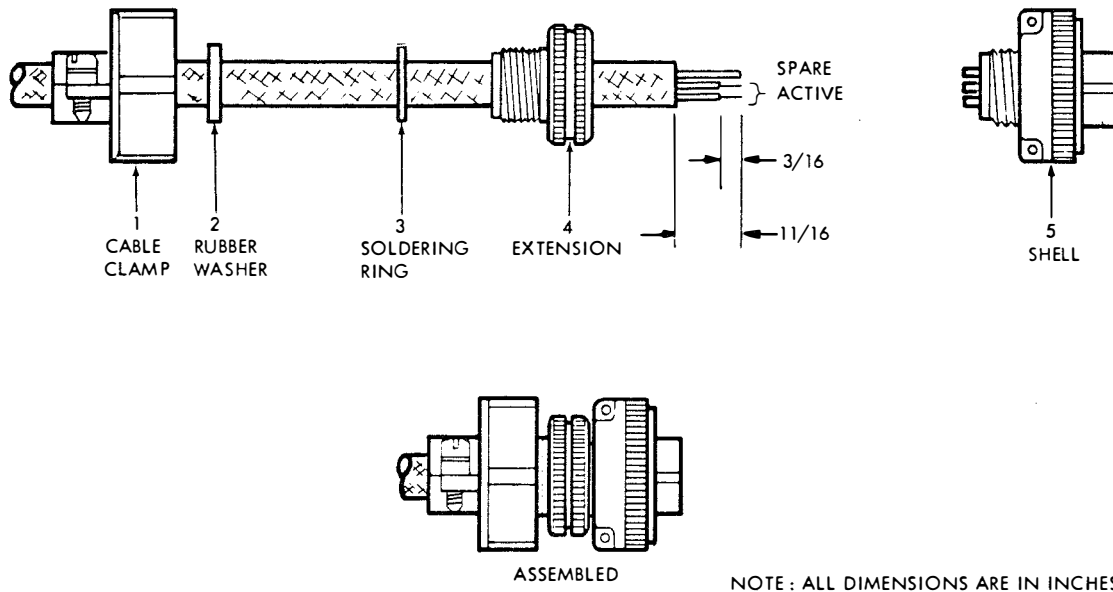

Figure 2-9. Attaching MS Plug to TTHFWA-1/2 Cable

Figure 2-10

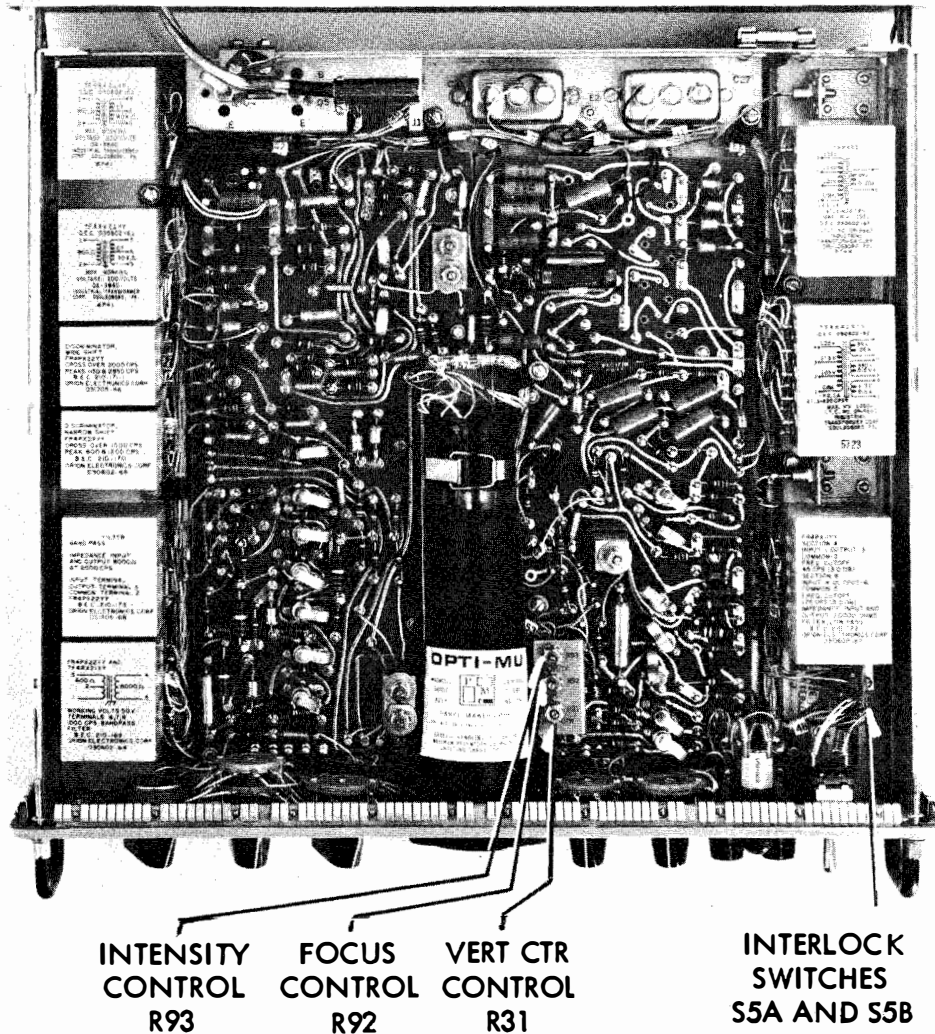

Figure 2-10. Location of Cathode-Ray Tube Controls

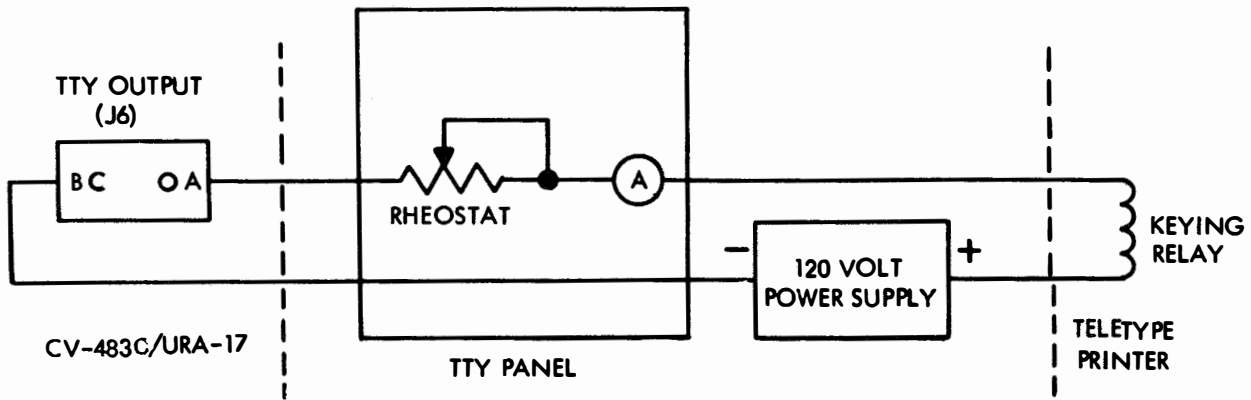

Figure 2-11. Teletype Printer DC Keying Relay Circuit, Simplified Schematic Diagram

SECTION 3 OPERATOR'S SECTION

3-1. FUNCTIONAL OPERATION.

a. GENERAL. - Comparator-Converter Group AN/URA-17C, hereinafter referred to as the AN/URA-17C, is used to convert the frequency-shift-keyed (fsk) audio output of standard radio receivers into dc pulses for the operation of teletype printers. The AN/URA-17C may be used in one or two single-channel receiving systems or in a single 'diversity' system.

b. FREQUENCY-SHIFT METHOD OF COMMUNICATION. - In the frequency-shift method of communication, code messages are transmitted as shifts in the rf carrier frequency. These frequency shifts represent the mark and space portions of code characters for operation of a teletype printer. Radio receivers are used to change these rf carrier frequency shifts into audio tones containing the same frequency shift information. Coded messages transmitted at speeds to 400 words per minute may be received and recorded in this system.

The AN/URA-17C consists of two Frequency Shift Converters CV-483C/URA-17. The CV-483C/URA-17, hereinafter referred to as the converter, changes audio frequency tones into dc pulses for operation of a teletype printer.

c. DIVERSITY OPERATION. - The AN/URA-17C may be used with two radio receivers operating in a diversity system. There are two methods of diversity operation, space-diversity and frequency-diversity. Diversity operation provides an improvement over single-receiver operation by reducing the effects of signal fading.

In space-diversity operation, two receivers are tuned to the same frequency but their antennas are spaced several wavelengths apart. An rf carrier usually does not fade simultaneously at spots that are several wavelengths apart.

In frequency-diversity operation, two receivers are tuned to different rf carrier frequencies, each carrying the same frequency-shift information. Carriers of different frequencies do not generally fade simultaneously at a given spot.

The audio output from the receivers is applied to the converters. The converters change the frequency-shifted audio signals into dc pulses representing the mark-space information. These dc pulses are applied to a comparator circuit in each converter. The comparator circuits continuously select the better of the two signals for control of the teletype printer. A teletype printer may be connected to the output of either converter.

d. SINGLE-RECEIVER OPERATION. - When conditions do not require diversity operation (strong signals with no evidence of fading), either converter may be used separately with a receiver for reception of fsk signals. In this mode of operation, the two converters may be used simultaneously in two independent single-receiver systems. A teletype printer is connected to the output of each converter.

3-2 OPERATING PROCEDURES.

a. GENERAL. - Since the AN/URA-17C is part of a system for the reception of coded teletype messages, the operator must be familiar with the complete system before attempting any of the following procedure.

b. DESCRIPTION OF CONTROLS. - All controls normally used during operation are located on the front panels of the two identical converters (figure 3-1). Table 3-1 lists all operator's controls by name and function. Other controls are to be adjusted only by a technician.

c. SEQUENCE OF OPERATION.

(1) BEFORE USE. - Ascertain if equipment is connected for diversity or single-receiver operation. Allow the associated receivers and teletype printer(s) to warm up (see applicable technical manuals). Turn the converter POWER switches to the On (up) position and allow a five minute warmup period.

(2) DURING USE. - Adjust converters and associated equipment as directed in paragraph 3-2g(1) for single-receiver operation or paragraph 3-2g(2) for diversity operation.

(3) SECURE. - To secure the AN/URA-17C, turn POWER switch on each converter to Off (down) position.

d. INDICATOR PRESENTATIONS. - Figure 3-2 illustrates the tuning indicator displays obtained when the associated receiver is properly tuned (A) and when the associated receiver needs retuning (B or C).

e. TUNING ADJUSTMENTS.

(1) SINGLE-RECEIVER OPERATION. - The need for retuning the associated receiver to compensate for frequency drift can be determined by observing the converter tuning indicator pattern (figure 3-2). If the pattern departs from that in (A) of figure 3-2, retune the receiver.

(2) DIVERSITY OPERATION. - Retuning the

TABLE 3-1. FREQUENCY SHIFT CONVERTER CV-483C/URA-17,
OPERATING CONTROLS

CONTROL	POSITION	FUNCTION
LEVEL	Variable, 0 to 10	Adjusts the signal level to the discriminator.
SHIFT	NARROW	Selects the narrow input filter and discriminator (10 to 200 cps shift width).
	WIDE	Selects the wide input filter and discriminator (200 to 1000 cps shift width).
FUNCTION	SINGLE	Used for single-receiver operation.
	TUNE	Used when tuning the receiver (removes the input signal from teletype printer).
	DIVERSITY	Used for diversity operation.
POLARITY	NORMAL	Used when keying pulses are of normal polarity.
	REVERSE	Used when keying pulses are of reversed polarity.
SPEED	FAST	Used for high speed keying signals.
	SLOW	Used for low speed keying signals.
POWER	On - Off	Turns line voltage on and off.

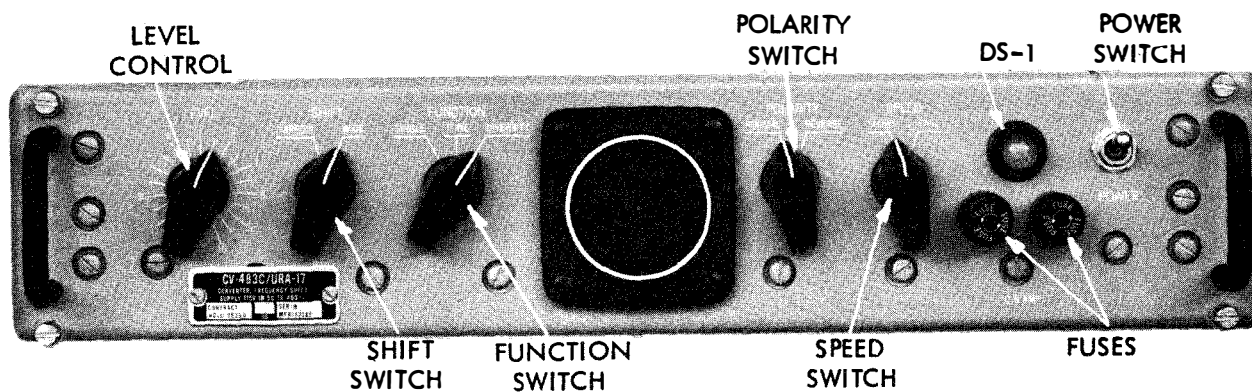

Figure 3-1. Frequency Shift Converter CV-483C/URA-17, Front Panel Controls

associated receivers to compensate for frequency drift is the same as for single-receiver operation. However, to prevent interruption of communication while one of the receivers is being tuned, set the FUNCTION switch of the associated converter to TUNE. During retuning, the other receiver-converter combination will operate the teletype printer. After the receiver has been tuned, set the converter FUNCTION switch to DIVERSITY.

are being received.

- Step 6. Adjust associated receiver bfo to 1 kc for narrow-shift signals or to 2.0 kc for wide-shift signals. If receiver has agc switch, turn on.
- Step 7. Tune receiver to desired rf signal. Set receiver

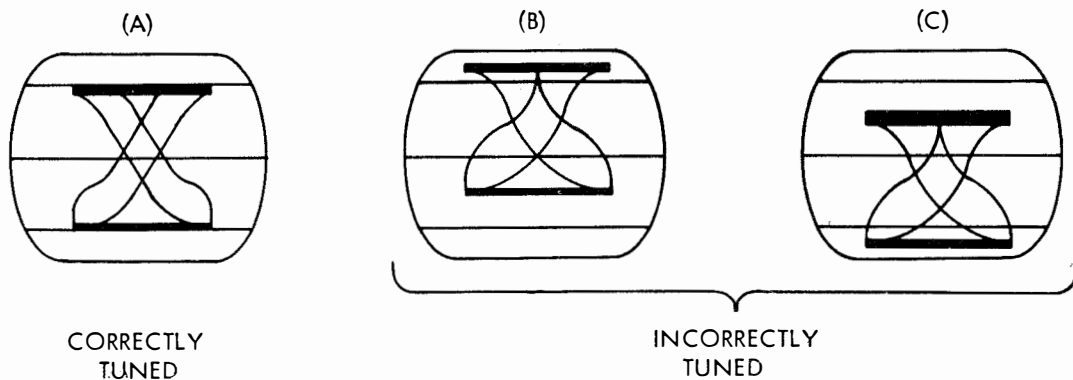

Figure 3-2. Tuning Indicator Patterns

f. ILLUSTRATIONS.

(1) CONTROLS. - The controls used by the operator are illustrated in figure 3-1 and listed in table 3-1.

(2) INDICATOR PRESENTATION. - Refer to figure 3-2 for tuning indicator presentations during receiver tuning.

g. MODES OF OPERATION. - The operator has a choice of two modes of operation: 1) single-receiver operation or 2) diversity operation.

(1) SINGLE-RECEIVER OPERATION. - Either converter may be adjusted for single-receiver operation, as follows:

- Step 1. Turn POWER switch to ON.
- Step 2. Set FUNCTION switch to TUNE.
- Step 3. Set POLARITY switch to NORMAL.
- Step 4. Set LEVEL control to 3.
- Step 5. Set SHIFT switch to WIDE if wide-shift signals (200 to 1000 cps) are being received or to NARROW if narrow-shift signals (10 to 200 cps)

bandwidth to approximately 800 cps for narrow-shift signals or to approximately 3 kc for wide-shift signals. Tune receiver until strongest beat-note is heard in headphones plugged in receiver headphone jack. Adjust receiver tuning for symmetrical, vertically centered pattern on tuning indicator (as in (A) figure 3-2). There are sometimes two receiver tuning positions that give a proper tuning indication; always select the stronger. Adjust audio output of receiver to 60 milliwatts.

- Step 8. Set converter SPEED switch to SLOW if single-channel teletype signals are being received or to FAST if four-channel, time-division multiplex is being received.
- Step 9. Adjust LEVEL control until pattern fills space between upper and lower horizontal lines on crt bezel.
- Step 10. Set FUNCTION switch to SINGLE.
- Step 11. Teletype printer should be printing properly. If not, set POLARITY switch to REVERSE.

(2) DIVERSITY OPERATION. - Each converter of the AN/URA-17C is adjusted for diversity operation as

follows:

- Step 1. Turn POWER switch to On.
- Step 2. Set FUNCTION switch to TUNE.
- Step 3. Set LEVEL control to approximately 3.
- Step 4. Set POLARITY switch to NORMAL.
- Step 5. Set SHIFT switch to WIDE if wide-shift signals (200 to 1000 cps) are being received or to NARROW if narrow-shift signals (10 to 200 cps) are being received.
- Step 6. Adjust associated receiver bfo to 1 kc for narrow-shift signals or to 2.0 kc for wide-shift signals. If receiver has age switch turn on.
- Step 7. Tune associated receiver to desired rf signal. Set receiver bandwidth to approximately 800 cps if narrow-shift signals are being received or to approximately 3 kc if wide-shift signals are being received. Tune receiver until strongest beat-note is heard in headphones plugged in receiver headphone jack. Adjust receiver tuning for a symmetrical, vertically centered pattern on tuning indicator (as in (A) figure 3-2). There are sometimes two receiver tuning positions that give a proper tuning indication; always select the stronger. Adjust audio output of receiver to 60 milliwatts.
- Step 8. Set converter SPEED switch to SLOW if single-channel teletype signals are being received or to FAST if four-channel, time-division multiplex is being received.
- Step 9. Adjust LEVEL control until pattern fills space between upper and lower horizontal lines on crt bezel.
- Step 10. Set FUNCTION switch to DIVERSITY.
- Step 11. The teletype printer should be printing properly. If not, set POLARITY switch to REVERSE.
- Step 12. Set FUNCTION switch to TUNE.
- Step 13. Repeat steps 1 through 11 for the second converter.
- Step 14. Set FUNCTION switch of first converter to DIVERSITY.

a. SINGLE-RECEIVER OPERATION.

- (1) Turn receiver and teletype printer power switches to On.
- (2) Set converter controls as follows:
 - (a) POWER Switch to On.
 - (b) FUNCTION switch to TUNE.
 - (c) POLARITY switch to NORMAL.
 - (d) LEVEL control to 3.
 - (e) SHIFT switch to WIDE (for wide-shift signals) or to NARROW (for narrow-shift signals).
- (3) Set receiver controls as follows:
 - (a) Set receiver bfo to 1 kc for narrow-shift signals or to 2.0 kc for wide-shift signals.
 - (b) Tune receiver to desired rf signal.
 - (c) Set receiver bandwidth to approximately 3 kc for wide-shift signals or to approximately 800 cps for narrow-shift signals.
 - (d) Tune receiver for strongest beat-note.
 - (e) Tune receiver for symmetrical, vertically centered pattern on converter tuning indicator. (If two receiver tuning positions occur, use stronger.)
 - (f) Adjust receiver audio output to 60 milliwatts.
- (4) Set converter SPEED switch to SLOW for single-channel teletype signals or to FAST for four-channel, time-division multiplex.
- (5) Adjust converter LEVEL control until pattern fills space between upper and lower horizontal lines on crt.
- (6) Set converter FUNCTION switch to SINGLE.

NOTE

If teletype printer is printing garbled copy, set converter POLARITY switch to REVERSE.

b. TO SECURE.

- (1) Turn converter POWER switch to Off.

3-3. SUMMARY OF OPERATING PROCEDURES.

c. DIVERSITY OPERATION.

- (1) Turn receiver and teletype printer power switches to On.
- (2) Set controls on one converter as follows:
 - (a) POWER switch to On.
 - (b) FUNCTION switch to TUNE.
 - (c) POLARITY switch to NORMAL.
 - (d) LEVEL control to 3.
 - (e) SHIFT switch to WIDE for wide-shift signals or to NARROW for narrow-shift signals.
- (3) Adjust associated receiver controls as follows:
 - (a) SET receiver bfo to 1 kc for narrow-shift signals or to 2.0 kc for wide-shift signals. If receiver has age switch, turn on.
 - (b) Tune receiver to desired rf signal.
 - (c) Set receiver bandwidth to approximately 3 kc for wide-shift signals or to approximately 800 cps for narrow-shift signals.
 - (d) Tune receiver for strongest beat-note.
 - (e) Tune receiver for symmetrical, vertically centered pattern on converter tuning indicator. (If two receiver tuning positions occur, use stronger.)

- (f) Adjust receiver audio output to 60 milliwatts.
- (4) Set converter SPEED switch to SLOW for single-channel teletype signals or to FAST for four-channel, time-division multiplex.
- (5) Adjust converter LEVEL control until pattern fills space between upper and lower horizontal lines on crt.
- (6) Set converter FUNCTION switch to DIVERSITY.

NOTE

If teletype printer is printing garbled copy, set converter POLARITY switch to REVERSE.

- (7) Set FUNCTION switch to TUNE.
 - (8) Repeat steps 2 through 6 for second converter.
 - (9) If teletype printer is printing garbled copy, set converter POLARITY switch to REVERSE.
 - (10) Set FUNCTION switch of first converter to DIVERSITY.
- d. TO SECURE.
- (1) Turn POWER switches of both converters to Off.

3-4 OPERATOR'S MAINTENANCE.

TABLE 3-2. OPERATOR'S CHECK CHART

CONTROL	SETTING	NORMAL INDICATION
Receiver power switch	On	Indicator light glows.
Receiver frequency control	To desired rf signal	Audio in headphones or loudspeaker; pattern on converter tuning indicator similar to A in figure 3-2.
Converter POWER switch	On	Indicator light glows.
Converter LEVEL control	---	Tuning indicator pattern fills space between horizontal lines on crt (see A in figure 3-2).
Teletype printer power switch	On	Teletype printer printing readable copy.

a. GENERAL. - Maintenance responsibility of the operator is limited to monitoring equipment controls and the tuning indicator during operation, plus indicator lamp and fuse replacement. If troubles develop in the system that cannot be remedied by the specific instructions in the following paragraphs, qualified maintenance personnel must be notified

b. ROUTINE CHECK CHART. - Table 3-2 outlines checks that should be made in the course of normal operation. If indications are other than normal, the operator should refer to the operator's troubleshooting chart, table 3-3. Troubles listed in table 3-3 should be considered and checked in the order given.

c. DAILY CHECK FOR CORRECT DIVERSITY OPERATION. - When the AN/URA-17C is used for diversity operation, a daily check should be made by the operator to assure optimum results.

The signals from both converters are compared in the converter to which the teletype printer is connected. Failure of one section of the comparator will eliminate the selection function and the advantage of diversity operation. To check for faulty section in the comparator, proceed as follows:

Step 1. Check each converter for single-receiver operation per paragraph 3-2g(1).

TABLE 3-3. COMPARATOR-CONVERTER GROUP AN/URA-17C,
OPERATOR'S TROUBLE-SHOOTING CHART

TROUBLE SYMPTOM	PROBABLE CAUSE	CORRECTION
Indicator light off with POWER switch On.	Defective indicator lamp bulb.	Replace bulb. Refer to paragraph 3-4d.
	Fuse blown.	Replace fuse. Refer to CAUTION and fuse replacement, paragraph 3-4e.
	Interlock switch open.	Tighten the four captive screws on front panel.
	AC power not on, or defective power input cable or connector.	Turn ac power on; report power failure. Check power input cable and connectors.
Still does not light.	---	Notify technician.
No tuning indicator display.	Blown fuse.	Replace fuse. Refer to CAUTION and fuse replace- ment, paragraph 3-4e.
Tuning indicator display not centered vertically.	Receiver mistuned.	Retune receiver. Refer to paragraph 3-2e.
Tuning indicator display centered and of proper amplitude, but tele- type printer is locked up.	Converter FUNCTION switch in TUNE position.	Set FUNCTION switch to SINGLE or DIVERSITY position, as applicable.
Tuning indicator display correct, but teletype printer runs open.	Teletype printer power supply defective.	Notify technician.
	Teletype printer defective.	Notify technician.

- Step 2. Connect receiver (tuned for fsk reception) to AUDIO INPUT receptacle on one converter (see figure 3-3).
- Step 3. Connect teletype printer to TTY OUTPUT receptacle on other converter.
- Step 4. Set FUNCTION switches on both converters to DIVERSITY.
- Step 5. Energize equipment.
- Step 6. If teletype printer prints readable copy, switch receiver and teletype printer connections to converters as shown by broken lines in figure 3-3. If teletype printer does not print, notify technician.

Release lamp by pressing in and turning counterclockwise. Insert new lamp and lock it in place by pressing in and turning clockwise. Reinstall the lens assembly.

e. FUSE REPLACEMENT. - Fuses F1 and F2 are mounted on the front panel (see figure 3-1). Both fuses are 1/2 ampere. To remove, press in on the cap, turn counterclockwise, and pull out the cap with the fuse attached. Remove and discard blown fuse. Insert a new fuse in the cap, insert cap in the holder, press in, and turn clockwise to lock. Replenish spare fuses from general stock.

CAUTION

Never replace a fuse with one of higher rating unless continued operation of the equipment is more important than possible damage to the equipment. If a fuse blows immediately after replacement, do not replace it a second time until the cause has been corrected.

NOTE

If teletype printer prints readable copy during one of the preceding tests, the equipment may be operated with teletype printer so connected until technician can make necessary repairs.

d. INDICATOR LAMP REPLACEMENT. - To replace indicator lamp, unscrew lens assembly from the front panel.

f. EMERGENCY MAINTENANCE. - No maintenance other than that described in this section is to be performed by the operator.

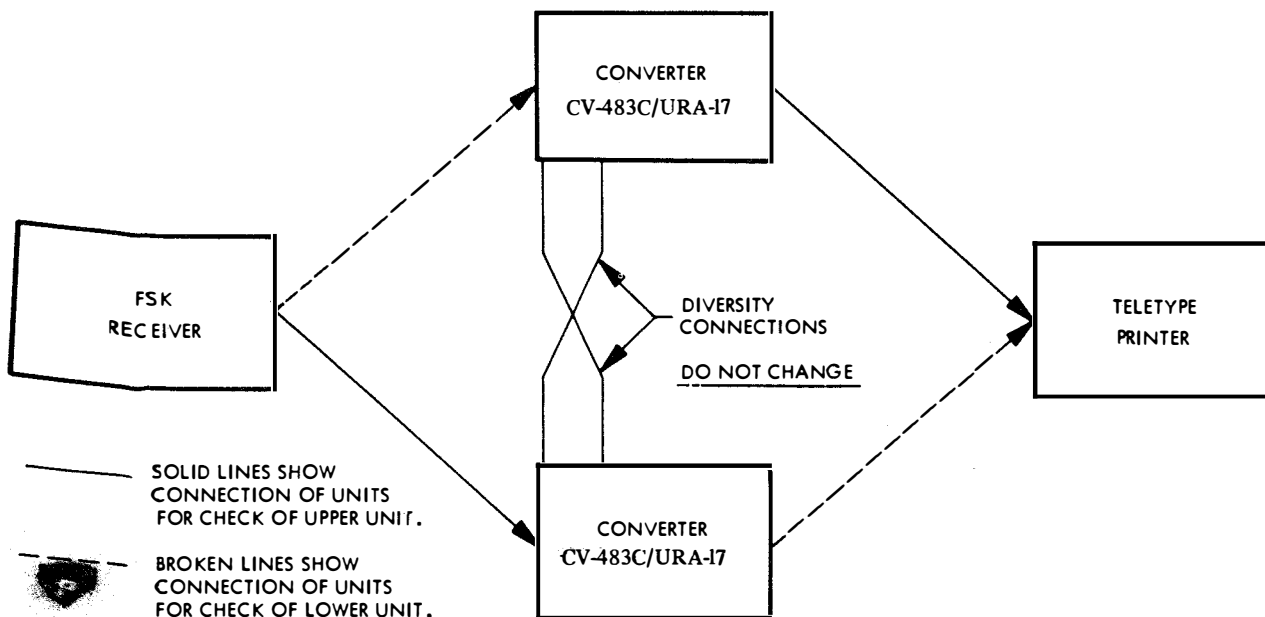

Figure 3-3. Connections between Receiver, Teletype Printer, and Converter Group for Daily Check of Diversity Operation

SECTION 4

PRINCIPLES OF OPERATION

4-1 OVERALL FUNCTIONAL DESCRIPTION.

a. **GENERAL.** - The overall function of Comparator-Converter Group AN/URA-17C is to provide a link in the receiving end of a frequency-shift communication system. The frequency-shift method of communication is a system of automatic code transmission, and reception, by means of a frequency modulated rf carrier. In this system, the mark and space portions of the code characters are represented by shifts above and below the rf carrier frequency.

The frequency-shift separation employed between mark and space signals may be as little as 10 cycles per second or as much as 1000 cycles per second. This scope of frequency-shifts is divided into two ranges called 'narrow shift' and 'wide shift.' Narrow shift covers the range of 10 to 200 cycles per second, and wide shift covers the range of 200 to 1000 cycles per second.

The system of reception to be considered here involves the use of a radio receiver for changing the rf carrier into an audio tone by means of a beat-frequency oscillator. The carrier-shift then becomes an audio frequency-shift of the same number of cycles per second.

b. **DIVERSITY OPERATION.** - Comparator-Converter Group AN/URA-17C consists of two Frequency Shift Converters CV-483C/URA-17, designed for use with two standard radio receivers operating in a diversity system. In space-diversity operation, the two receivers are tuned to the same frequency but the receiving antennas are spaced more than one wavelength apart. In frequency-diversity operation, the two receivers are tuned to separate frequency-shift carriers (of different frequencies) which are simultaneously carrying the same mark-space characters. The advantage of space-diversity operation for reception of distant signals results from the fact that a single rf carrier does not generally fade simultaneously at spots more than one wavelength apart. The advantage of frequency-diversity operation results from the fact that fading of carriers of different frequencies does not generally occur at the same time.

The output of each receiver is connected to one Frequency Shift Converter CV-483C/URA-17 (hereinafter referred to as the converter) which converts the frequency-shift characters into dc pulses. These pulses are applied to a comparator circuit in each of the converters. The comparators select the better of the two input signals for operation of the teletype printer. The teletype printer may be connected to the output of either converter.

c. **SINGLE-RECEIVER OPERATION.** - Where conditions do not require diversity operation, each converter may be used separately with a single receiver for reception of frequency-shift signals. In this case, the two converter

units may be used in two independent communication circuits.

d. **SIMPLIFIED BLOCK DIAGRAM.** - The simplified block diagram, figure 4-1, indicates the basic functions of converting the rf frequency-shift signal into a signal for controlling the dc loop of a teletype printer. The frequency shifts of the audio-frequency output of the radio receiver are converted into dc pulses by the action of an audio-frequency discriminator. The dc pulses are fed into a loop keyer which opens and closes the dc loop of the associated teletype printer in accordance with the mark and space characters received.

The frequency versus mark-space relationship shown in figure 4-1 is the most typical. The higher frequency represents the mark signal and the lower frequency represents the space signal. However, the opposite is also used, or the tuning and heterodyning of the signal in the receiver may reverse the relationship. When such reversed characters are applied to the teletype printer, garbled copy results. A reversing switch (not shown) is provided on each converter to reverse the relationship when required.

e. **FUNCTION BLOCK DIAGRAM.** - Figure 4-2 is a block diagram representing the principal functions of the circuits of the complete equipment. Two receivers and a teletype printer are also shown, connected for diversity operation. The two converters are identical and one is shown as a single block for simplicity. The receivers may be operating in space diversity or frequency diversity on any radio frequency within their ranges.

The converter circuits represented by the blocks are discussed separately in the following paragraphs. Reference should be made to the overall schematic, figure 6-5. For the functions of the individual component parts of figure 6-5, refer to the parts list, table 7-1, Section 7.

4-2 FUNCTIONAL SECTIONS.

a. **GENERAL.** - Each converter is a single unit with the filters and transformers mounted around the sides of printed circuit boards. In the following paragraphs, the converter is covered as three functional sections: 1) signal processing circuits, 2) Keyer circuits, and 3) power supplies (see figure 4-2). Waveforms at significant test points are illustrated in table 5-5. Refer to the overall schematic, figure 6-5, during the detailed theory which follows.

b. **SIGNAL PROCESSING CIRCUITS.** - The input signal from the receiver is applied to the **AUDIO INPUT** connector J2 (figure 6-5). A center-tap is provided at **STANDOFF E1** for the accommodation of balanced inputs. The input transformer matches the 8000 ohm impedance of the bandpass filter to the 600 ohm line from the receiver. The input

transformer is encased with the bandpass filter in Z1.

(1) **BANDPASS FILTERS.** - The bandpass filters attenuate high frequency noise pulses while passing both extremes of the shifted audio signal to the limiter. Selection of the correct filter for the shift-width of the input signal is made by section A of the SHIFT switch, S1. The narrow filter, Z1, is used when the center frequency of the input signal is 1000 cycles per second (cps) with shifts of 5 to 100 cps each side of center. The wide filter, FL1, is used when the center frequency of the input signal is 2000 cps with shifts of 100 to 500 cps each side of center. The characteristics of the bandpass filters are given in table 6-2.

(2) **LIMITER.** - The limiter holds the output level at the detector to within 2 db with input signals of from 60 microwatts to 60 milliwatts. The limiter consists of two 1N538 silicon diodes, CR1 and CR2, connected in parallel with opposite polarities grounded. These diodes have a very high forward resistance to signals below approximately 0.6 volt in amplitude. Their resistance is very low to signals of greater amplitude. By maintaining the signal level at approximately 0.6 volt, strong noise pulses are removed from the input signal and the signal to the discriminator is held at a constant level with fading input signals. The limiter output is amplified by Q1, a common-emitter amplifier that uses the LEVEL control, R4, as a collector load. The LEVEL control is used for adjustment of the signal level to the discriminators. The signal level during reception of a narrow-shift signal must be higher than when receiving a wide-shift signal. The amplified signal is applied to the discriminator through section B of SHIFT switch S1.

(3) **DISCRIMINATORS.** - The discriminators are frequency-selective networks that determine the frequency versus amplitude slope of the mark and space signals. Each discriminator consists of two resonant networks with overlapping frequency response patterns (see figure 4-3).

The narrow-shift discriminator, FL2, is used for signals with shift-widths of from 10 to 200 cps. The output from terminal 1 of the narrow-shift discriminator increases with frequency to a maximum at about 1200 cps. At terminal 4 the output increases as frequency decreases to a maximum at about 800 cps. The cross-over point at which the voltages from terminals 1 and 4 are equal is 1000 cps \pm 15 cps.

The wide-shift discriminator, FL3, is used for input signals with shift-widths between 200 and 1000 cps. The wide-shift discriminator contains two resonant networks with a cross-over frequency of 2000 cps \pm 40 cps. The output from terminal 1 increases with frequency to about 2850 cps. The output from terminal 4 increases as frequency decreases to a maximum at approximately 1150 cps.

The output from terminal 1 of the discriminator is applied to the first mark amplifier, and the output from terminal 4 is applied to the first space amplifier. The characteristics of the discriminators are given in figure 6-1.

(4) **MARK-SPACE AMPLIFIERS.** - The first mark amplifier, Q2, is common-emitter connected. Fixed base biasing is provided by R11 and R12. The MARK GAIN control, R96, provides adjustment of the signal gain by controlling degeneration in the emitter circuit. The mark signal is coupled from the collector of Q2 to the base of Q4, the second mark amplifier, by C8. The space amplifiers, Q3 and Q5, are identical to the mark amplifiers. The SPACE GAIN control is R17. The MARK GAIN and SPACE GAIN controls allow equalizing the mark and space amplifier outputs at the cross-over frequencies. The mark amplifier output signal is applied to the primary of discriminator transformer T1. The space amplifier output is applied to the primary of discriminator transformer T2.

(5) **DETECTOR.** - The detector rectifies and combines the outputs of the discriminator transformers

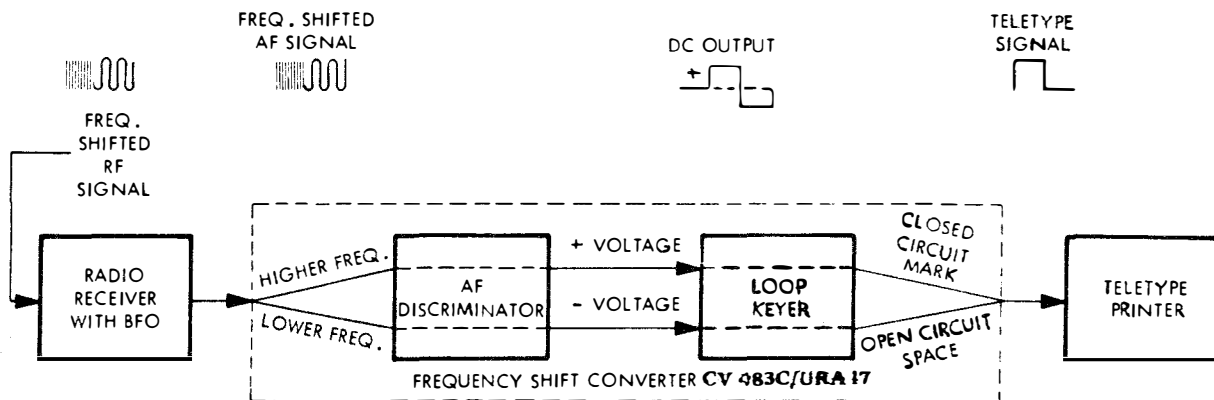

Figure 4-1. Frequency-Shift Receiving System, Simplified Block Diagram

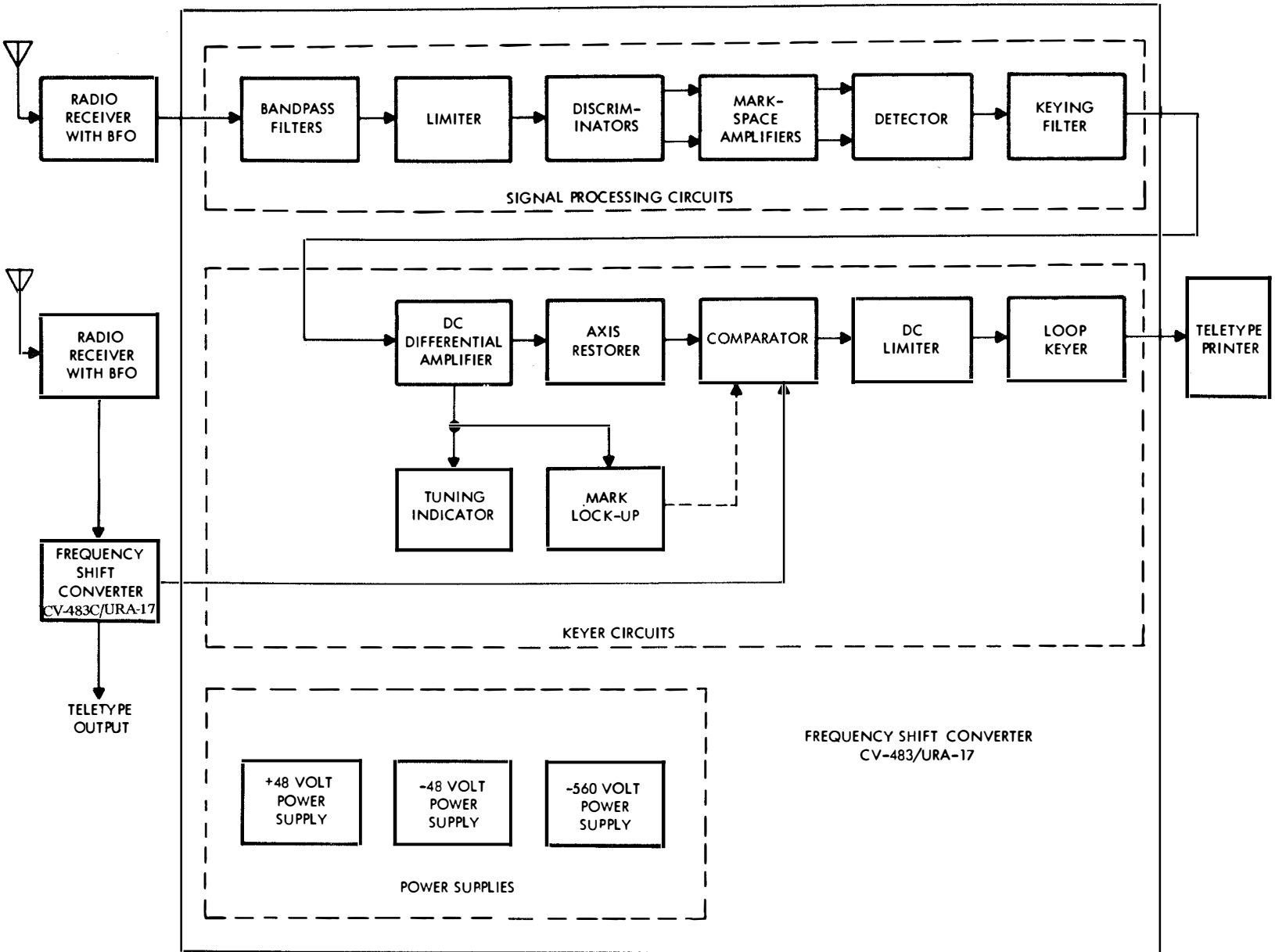
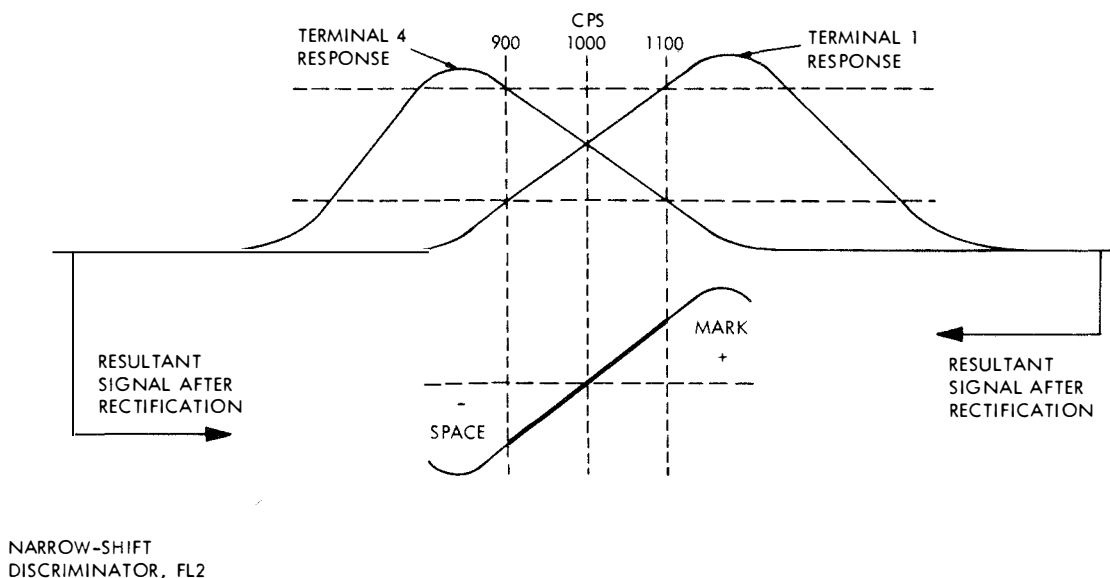
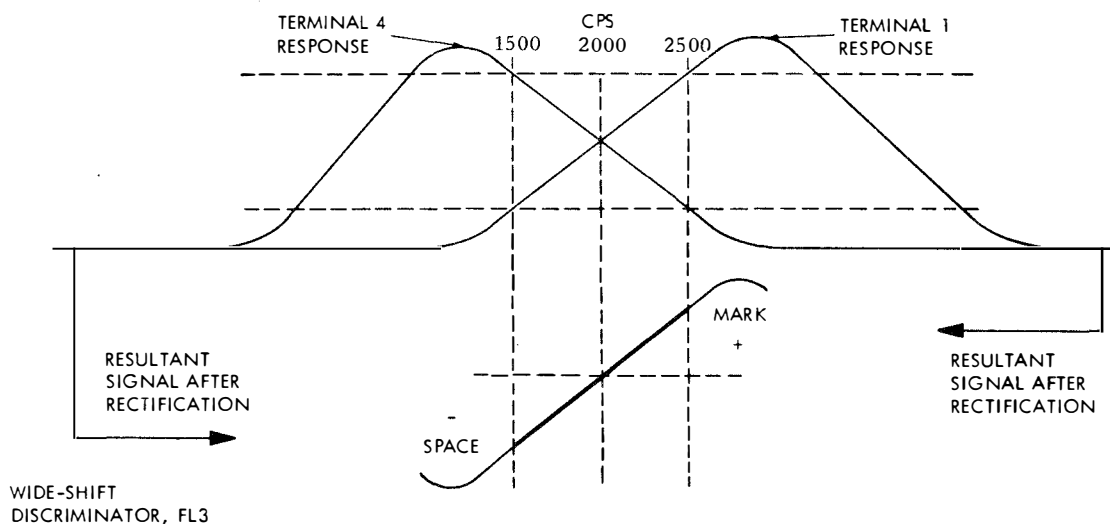

Figure 4-2. Comparator-Converter Group AN/URA-17C, Functional Block Diagram



NARROW-SHIFT
 DISCRIMINATOR, FL2



WIDE-SHIFT
 DISCRIMINATOR, FL3

Figure 4-3. Discriminator Response Curves

into a pulsating dc which contains the mark-space intelligence. The mark signal at the secondary of T1 is full-wave rectified by CR3 and CR4, and the space signal at the secondary of T2 is full-wave rectified by CR5 and CR6. The rectified mark and space signals are next combined across R25 and R26 (see figure 4-4). The dc signal from the detector is applied to the POLARITY switch, S2.

In conventional frequency-shift keying transmissions, the high frequency portion of the shifted signal corresponds to teletype mark pulses and the low frequency corresponds to space pulses. Because of unusual conditions, the mark-space relationship may be reversed. When such reversed charac-

ters are applied to a teletype printer, garbled copy results. The POLARITY switch, S2, is provided for inverting the mark-space relationship when required.

(6) KEYING FILTER. - The low-pass keying filter, FL4, removes noise pulses and the carrier from the signal at the output of the detector. The keying filter consists of two sections, with selection being made by the position of the SPEED switch, S3. When the switch is in the SLOW position, the keying filter section passes keying signals up to 100 words per minute, and attenuates all frequencies above 45 cps. The other section of the keying filter, selected by the FAST position of the SPEED switch, passes

keying signals up to 400 words per minute (four-channel, time-division multiplex, up to 100 words per minute per channel), and attenuates all frequencies above 180 cps. Keying filter characteristics are included in table 6-2.

c. **KEYER CIRCUITS.** - The pulsating dc signals from the detector are converted by the keyer circuits into off-on pulses for operation of the teletype printer relay.

(1) **DC DIFFERENTIAL AMPLIFIER.** - The dc differential amplifier provides amplification of the mark-space signals before they are applied to the dc limiter. Transistors Q6 and Q9 comprise an emitter-coupled amplifier. The input to the base terminal of Q6 is the output signal from the keying filter; the input to the base terminal of Q9 is supplied by Q10, via the feedback resistor, R41, from the output of the dc differential amplifier. These two signals are amplified by another emitter-coupled amplifier consisting of Q7 and Q8. The two signals (input and feedback) are mixed in Q8 and then applied to the base terminal of the output transistor, Q10. Zener diodes CR7 and CR8 establish -32 volts at the emitter of Q10.

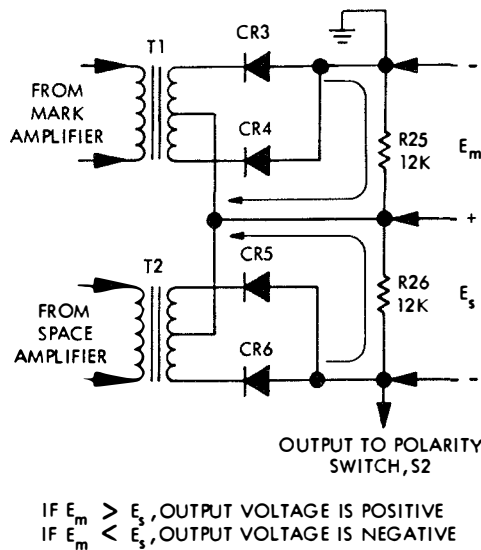

Figure 4-4. Discriminator Detector, Simplified Diagram

The feedback from the output to the base of Q9 stabilizes the gain of the dc differential amplifier over wide temperature variations. The VERTICAL CRT control, R31, is adjusted for vertical centering of the tuning indicator display and establishes zero balance of the amplifier. The LIN (linearity) control, R39, (part of the voltage divider for the base terminal of Q10), is provided to adjust the bias of Q10 for the most linear signal capability.

The input signal to the base of Q6 is approximately +1.7 for the mark and space signals. The dc differential amplifier raises this level to approximately +20 volts. This level is

suitable for operating the mark lock-up, the tuning indicator, the axis restorer, and subsequent keying circuitry.

(2) **AXIS RESTORER.** - The axis restorer maintains the signal axis at ground potential and restores signal symmetry when the transmitter or receiver frequency drifts during operation. The positive mark signal from the dc differential amplifier charges C17 and C18 through CR9 which clamps the signal to ground. The negative space signal charges C19 and C20 through CR10 which clamps the signal to ground. The signals are combined again through R45 and R46. By clamping both the mark and space signals separately and then recombining them, the signal axis is automatically placed at ground potential. The signal is coupled to the comparator through the FUNCTION switch, S4.

(3) **COMPARATOR.** - The main function of the comparator is to compare the strength of signals from the two receivers during diversity operation, and allow only the stronger signal to be applied to the dc limiter. The comparator consists of CR14, CR15, CR16, CR17, R54, and R55. In diversity operation, two converters are used with two receivers for the operation of a single teletype printer. The signals are compared at the comparator in each of the converters (see figure 4-5), with the stronger signal being applied to the dc limiter. The FUNCTION switch, S4, on both converters must be placed at DIVERSITY. The teletype printer may be connected to either converter.

In figure 4-5, the peak amplitudes of both input signals are equal but the signal from converter A contains noise. The signal from converter B has a constant peak value of +20 volts and will develop a greater voltage across R54 and CR16, preventing converter A from actuating the dc limiter. The FUNCTION switch, S4, has two other positions, SINGLE and TUNE. In the SINGLE position, the positive mark pulses cause CR16 to conduct and negative space pulses cause CR14 to conduct. In the TUNE position, the signal input to the dc limiter is removed while the receiver is being tuned. A small, positive voltage is applied to the dc limiter input by R56 and R57 to lock up the teletype printer during the interruption in the input signal. Without the positive voltage, the teletype printer would run open.

(4) **DC LIMITER.** - The dc limiter, Q13, Q14, Q15, Q16, and associated circuit, is a class B pushpull circuit which supplies approximately 20 db of post-detection limiting and aids in proper operation during reception of signals containing strong noise pulses. The signal from the comparator is applied simultaneously to the base terminals of Q13 (an npn transistor), and Q15 (a pnp transistor). A positive mark signal causes Q13 to conduct but cut off Q15. The collector of Q13 is direct-coupled to the base of Q14. The signal is phase-shifted 180 degrees by Q13, causing Q14, a pnp transistor, to conduct and deliver a strong positive signal at its output. A negative space signal causes Q15 to

conduct but cuts off Q13. The collector of Q15 is direct-coupled to the base of Q16 (an npn transistor), and because of the 180 degree signal voltage phase-shift, Q16 conducts and delivers a strong negative signal at its output. The dc limiter controls the switching action of the loop keyer.

(5) LOOP KEYER. - The function of the loop keyer, Q17, Q18, and associated circuit, is operation of the teletype printer loop relay. The teletype printer loop keyer circuit consists of a 120 volt dc power supply, a relay winding, and a variable resistor used for adjusting the loop current to 60 ma (see figure 4-6). The 120 volt dc at J6 is applied across Q17, Q18, and R67 in series. When a positive (mark) signal is applied to the base of Q18, the forward base-emitter bias of Q18 is increased and Q18 conducts heavily. The heavy emitter-collector current in Q18 causes the emitter of Q17 to become more negative and Q17 conducts, closing the teletype printer keying relay. When a negative (space) signal is applied to the base of Q18, the forward base-emitter bias is reduced. This lowers the emitter-collector current of Q18 and the forward base-emitter bias of Q17, opening the teletype printer relay. The relay remains open until another positive (mark) signal is applied. Diode CR19 prevents a large emitter-base voltage (caused by an increase in the emitter-collector resistance of Q18) from damaging the emitter junction of Q17. Diode CR18 prevents the teletype power supply (+120 volts) from feeding into the converter +48

Zener diodes CR21 and CR22 protect Q17 and Q18 from the inductive kickback voltage produced in the teletype printer relay.

(6) MARK LOCK-UP. - The mark lock-up provides a strong, artificial mark signal to the dc limiter during traffic interruptions. If a deep fade occurred or if the signal-to-noise ratio were very low, noise pulses could cancel the small positive bias on the dc limiter input, provided by R56 and R57, and allow garbled copy to be printed. A steady mark signal is transmitted between messages. This steady mark signal charges C17 in the axis restorer allowing no signal to be applied to the dc limiter. The mark lock-up, Q11, Q12, and circuit, provides a bypass around the axis restorer (shown as dashed line in figure 4-2) during these signal interruptions.

During normal keying pulses, C32 charges through CR11 on the negative space pulses and slowly discharges through R48 and CR12, keeping Q11 cut off. While Q11 is cut off, Q12 conducts heavily (having a high base-emitter forward bias), reducing the voltage at the junction of R52 and R53 to near zero. When the keying pulses stop, the charge on C32 leaks off to the point where Q11 conducts, removing the forward bias from Q12 and causing it to cut off. When Q12 is cut off, +48 volts is supplied to the dc limiter from the junction of R52 and R53. When keying is resumed, the first mark-to-space transition charges C32 to a level which cuts off Q11 and turns on Q12, removing the artificial mark signal.

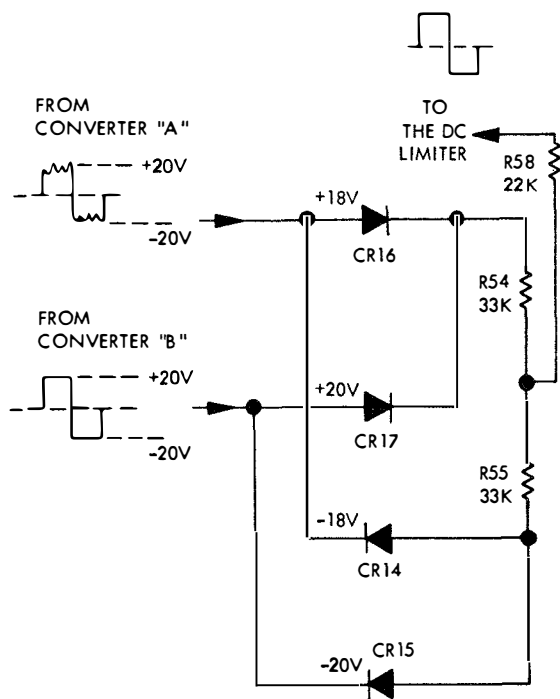

Figure 4-5. Comparator Circuit,
Simplified Schematic Diagram

volt supply. Diode CR20 prevents damage to the converter in the event the teletype power supply is reversed.

(7) TUNING INDICATOR. - Tuning indicator V1 is a 2B1 cathode-ray tube. Horizontal deflection voltage (60 cps) is obtained from the high voltage transformer T4. Controls for HORIZONTAL CENTERING, FOCUS, INTENSITY, VERTICAL ADJUSTMENT, VERTICAL CRT, and LINEARITY (R77, R92, R93, R80, R31, and R39, respectively) are provided on the converter chassis as screwdriver adjustments. The vertical deflection voltage is supplied from the dc differential amplifier output. When the associated receiver is tuned properly, the crt pattern will be centered vertically. The LEVEL control adjustment is correct when the horizontal lines of the pattern coincide with those on the bezel.

d. POWER SUPPLIES. - Three dc power supplies furnish all operating voltages and currents required by the converter. The ac line voltage is applied to POWER receptacle, J3, on the rear of the converter cabinet. Safety interlocks, S5A and S5B, and fuses, F1 and F2 (1/2 ampere each), are installed in the ac input lines. The indicator, DS-1, lights when power is applied to the converter by POWER switch S6. The two power transformers, T3 and T4, have tapped primaries to allow operation on line voltages of 105, 115, or 125 volts.

(1) +48 VOLT SUPPLY. - For the AN/URA-17C, the +48 volt supply consists of a full wave rectifier and CR34, a zener diode, for regulation. The full wave

rectifier consists of diodes CR29 and CR31. Resistor R85 limits the zener current. Capacitors C28 and C30 in conjunction with R85 comprise an RC ripple filter.

(2) -48 VOLT SUPPLY. - For the AN/URA-17C the -48 volt supply consists of a full wave rectifier and CR27, a zener diode, for regulation. The full wave rectifier consists of diodes CR23 and CR25. Resistor R68 limits the zener

currents capacitors C22, C23 and C24 in conjunction with R60, R75 and R74 comprise an RC ripple filter.

(3) -560 VOLT SUPPLY. - The -560 volt supply uses one IN1731 diode, CR32 as a half-wave rectifier. A voltage divider consisting of R91, R92, R93, and R94 provide the high voltages required by the crt.

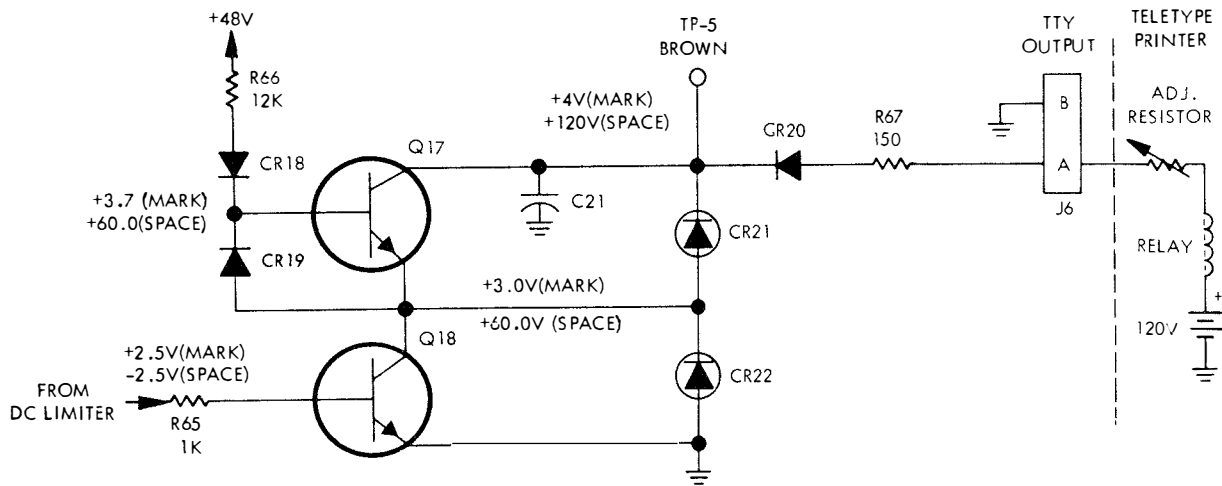

Figure 4-6. Loop Keyer and Teletype Printer Keying Circuits

SECTION 5 TROUBLE-SHOOTING

5-1. GENERAL.

Comparator-Converter Group AN/URA-17C, hereinafter referred to as the AN/URA-17C, is part of a system for the reception and recording of transmitted teletype messages.

The AN/URA-17C consists of two Frequency Shift Converters CV-483C/URA-17, hereinafter referred to as the converters.

Maintenance personnel should be thoroughly familiar with the operation of the overall frequency-shift receiving system, and the function of each equipment used. The receivers and teletype printers used with the AN/URA-17C should be tested, adjusted, and maintained in accordance with their individual maintenance instructions.

Prior to trouble-shooting the AN/URA-17C, the technician should become familiar with the equipment operation during normal conditions. By keeping records of discrepancies occurring during operation, it may be possible to prevent equipment breakdown by foreseeing failures. It is mandatory that maintenance personnel read Section 1, 3, and 4 of this technical manual before performing any trouble-shooting procedures.

It is assumed that maintenance personnel are experienced in standard methods of testing and repairing naval electronic equipment; therefore, detailed descriptions of common tests are not given.

As an aid in trouble-shooting, the following system of test point symbols is used in tables and illustrations of this manual. The major test point symbol consists of the test point number enclosed within a star. The secondary test point symbol consists of the test point letter enclosed within a circle. Figure 5-2 shows locations of all test points used in this manual. In the text, major test points are shown as ★ 1, ★ 2, etc., and secondary test points are shown as ● A, ● B, etc.

5-2. TEST EQUIPMENT AND SPECIAL TOOLS.

a. TEST EQUIPMENT. - The following test equipment, or the equivalent (refer to table I-3), will be required:

DuMont 304-A	oscilloscope
ME-30/U	ac vtm
AN/PSM-4	multimeter
TS-1100/U	test set, transistor

b. SPECIAL TOOLS. - No special tools will be required.

5-3. OVERALL TROUBLE-SHOOTING.

a. PRELIMINARY CHECK. - A preliminary check of the equipment should be made before proceeding to the trouble-shooting charts. The first and most natural step in trouble-shooting is to analyze the symptoms of the equipment. Often the conclusions reached will aid the technician in selecting the test(s) that will most quickly locate the cause of trouble. The operator's maintenance tests in Section 3 will be of assistance in making this analysis. Normally, the malfunction can be traced to the receiver, the teletype printer, or one of the converters.

When possible, use sensory tests, such as visually checking parts (fuses, resistors, capacitors, etc.), and smelling or feeling for signs of overheating. Simple tests often will reveal the difficulty.

NOTE

If, during the preliminary check, a part is found that is responsible for the malfunction, determine what caused its failure before replacing it.

Malfunctons other than the result of faulty transmission, bad receiving conditions, or improper operating methods must first be localized to one of the system components. If the evidence is not definite, a simple expedient is to substitute equipment known to be in proper operating condition for the suspected equipment.

The receiver may be tested independently by monitoring the audio output with a headset or loudspeaker and tuning in various signals.

The teletype printer may be checked with signals from another source of known accuracy, such as another teletype circuit.

The best method of testing the converter is by recording its output with a teletype printer or other automatic recorder.

During the tests given in the following paragraphs, the converter is to be connected to a receiver adjusted to receive fsk signals and a teletype printer is to be connected to the output of the converter. The receiver and teletype printer are to be in satisfactory operating condition.

b. TEST EQUIPMENT AND SPECIAL TOOLS. - No test equipment or special tools are required.

c. CONTROL SETTINGS. - Set the converter controls as follows:

- (1) LEVEL control to 0.
- (2) SHIFT switch to NARROW.
- (3) FUNCTION switch to TUNE.
- (4) POLARITY switch to NORMAL.
- (5) SPEED switch to SLOW.
- (6) POWER switch to Off (down).

d. SYSTEM TROUBLE-SHOOTING CHART. - The system trouble-shooting chart, table 5-1, will aid the technician in isolating a malfunction to a functional section (paragraph 5-4) Table 5-1 is arranged so as to utilize the converter's front panel indicators as a means of determining which functional section is defective.

If the technician is thoroughly familiar with the equipment, he may start directly with functional section trouble-shooting. Refer to the overall schematic diagram, figure 6-5, during performance of the trouble-shooting procedures.

(1) MALFUNCTION DURING SINGLE-RECEIVER OPERATION. - If the equipment is rejected for malfunction during single-receiver operation, perform the procedures listed in table 5-1.

(2) MALFUNCTION DURING DIVERSITY OPERATION. - If the equipment is rejected for malfunction during diversity operation, proceed as follows:

Step 1. Check each converter for single-receiver operation (Section 3, paragraph 3-2g(1)). If operation is satisfactory, continue with step 2 of this paragraph. If not, perform the procedures listed in table 5-1.

Step 2. Perform steps in Section 3, paragraph 3-4c. If, upon completion of the diversity check listed in paragraph 3-4c, the teletype printer does not print, check CR15 and CR17 (figure 6-3) in converter to which teletype printer is connected.

5-4. FUNCTIONAL SECTION TROUBLE-SHOOTING.

TABLE 5-1. FREQUENCY SHIFT CONVERTER CV-483C/URA-17,
SYSTEM TROUBLE-SHOOTING CHART

STEP	PRELIMINARY ACTION	NORMAL INDICATION	NEXT STEP
1	Turn converter POWER switch to On.	Indicator lamp glows.	If lamp glows, proceed to step 2; if not, proceed to table 5-4, step 1.
2	Connect fsk receiver audio output to AUDIO INPUT jack (J2) at rear of converter cabinet. Adjust receiver and converter controls for single-receiver operation (Section 3, paragraph 3-2g(1), steps 1 through 10).	Tuning indicator pattern as (A) in figure 3-2.	If pattern is ok, proceed to step 3; if not, proceed to table 5-2, step 1.
3	Connect teletype printer to TTY OUTPUT jack (J6) at rear of converter.	Teletype printer prints readable copy.	If teletype printer does not print readable copy, place POLARITY switch to REVERSE. If trouble still persists, proceed to table 5-3.

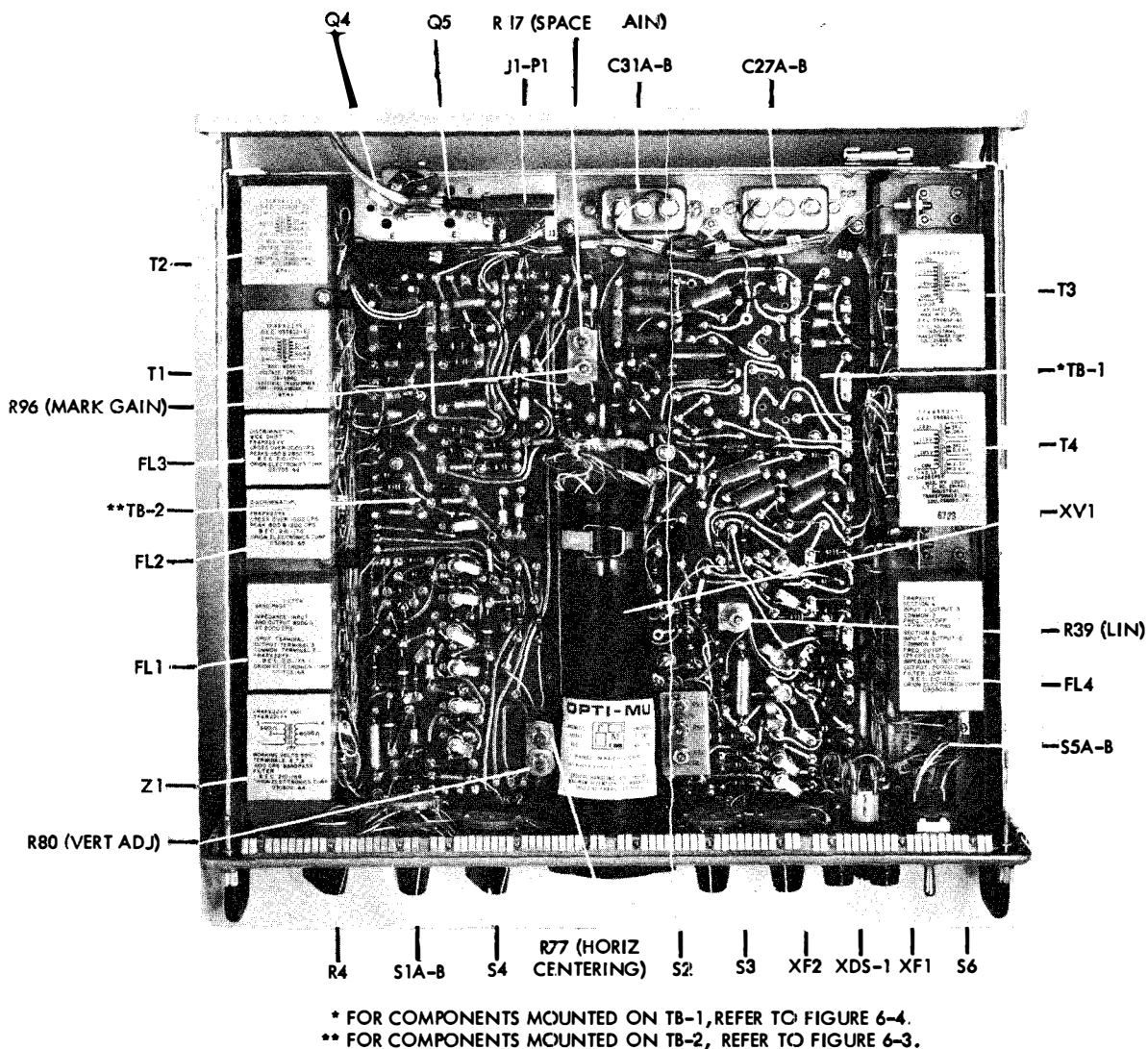

Figure 5-1. Frequency Shift Converter CV-483C/URA-17, Parts Location

a. GENERAL. - Functional section trouble-shooting will aid the technician in isolating the malfunction to a defective part or parts. Tables 5-2, 5-3, and 5-4 are the functional section trouble-shooting charts for the three functional sections of this equipment: i.e., signal processing circuits; keyer circuits; and power supplies.

b. SIGNAL PROCESSING CIRCUITS TROUBLE-SHOOTING.

(1) PRELIMINARY CHECK. - The preliminary check for functional trouble-shooting of the signal processing circuits is the same as the preliminary check for overall trouble-shooting (refer to paragraph 5-3a).

(2) TEST EQUIPMENT AND SPECIAL TOOLS.

(a) TEST EQUIPMENT. - The following test equipment will be required:

DuMont 304-A	oscilloscope
ME-30/U	ac vtm
AN/PSM-4	multimeter
TS-1100/U	test set, transistor

(b) SPECIAL TOOLS. - No special tools will be required.

(3) CONTROL SETTINGS. - The control settings for the converter during functional trouble-shooting of the signal processing circuits are the same as the control settings for overall trouble-shooting (refer to paragraph 5-3c).

(4) ILLUSTRATIONS

(a) TEST POINTS. - Figure 5-2 Illustrates the physical locations of all test points to be used in functional section trouble-shooting.

(b) SCHEMATIC DIAGRAMS. - Figure 5-4 is the schematic diagram of the signal processing circuits.

(c) VOLTAGE AND RESISTANCE DIAGRAM. - Figure 5-3 lists dc voltages and resistance measured from the terminals of the transistors in the signal processing circuits to the converter chassis, with no signal applied.

(d) SIGNAL TRACING OSCILLOSCOPE PATTERNS. - Table 5-5 illustrates oscilloscope patterns to be used as guides during signal tracing.

(e) ALIGNMENT OF THE CONVERTER AFTER TROUBLE-SHOOTING. - After trouble-shooting

the signal processing circuits, if repairs of component changes were made, refer to Section 6, paragraph 6-2, for alignment procedures. Table 6-1 lists adjustments required after specific transistors are replaced or values in the circuits of these transistors are changed.

c. KEYSER CIRCUITS TROUBLE-SHOOTING.

(1) PRELIMINARY CHECK. - The preliminary check for functional trouble-shooting the keyser circuits is the same as the preliminary check for overall trouble-shooting (refer to paragraph 5-3a).

(2) TEST EQUIPMENT AND SPECIAL TOOLS.

(a) TEST EQUIPMENT. - The following test equipment will be required:

DuMont 304-A	oscilloscope
ME-30/U	ac vtvm
AN/PSM-4	Multimeter
TS-1100/U	test set, transistor

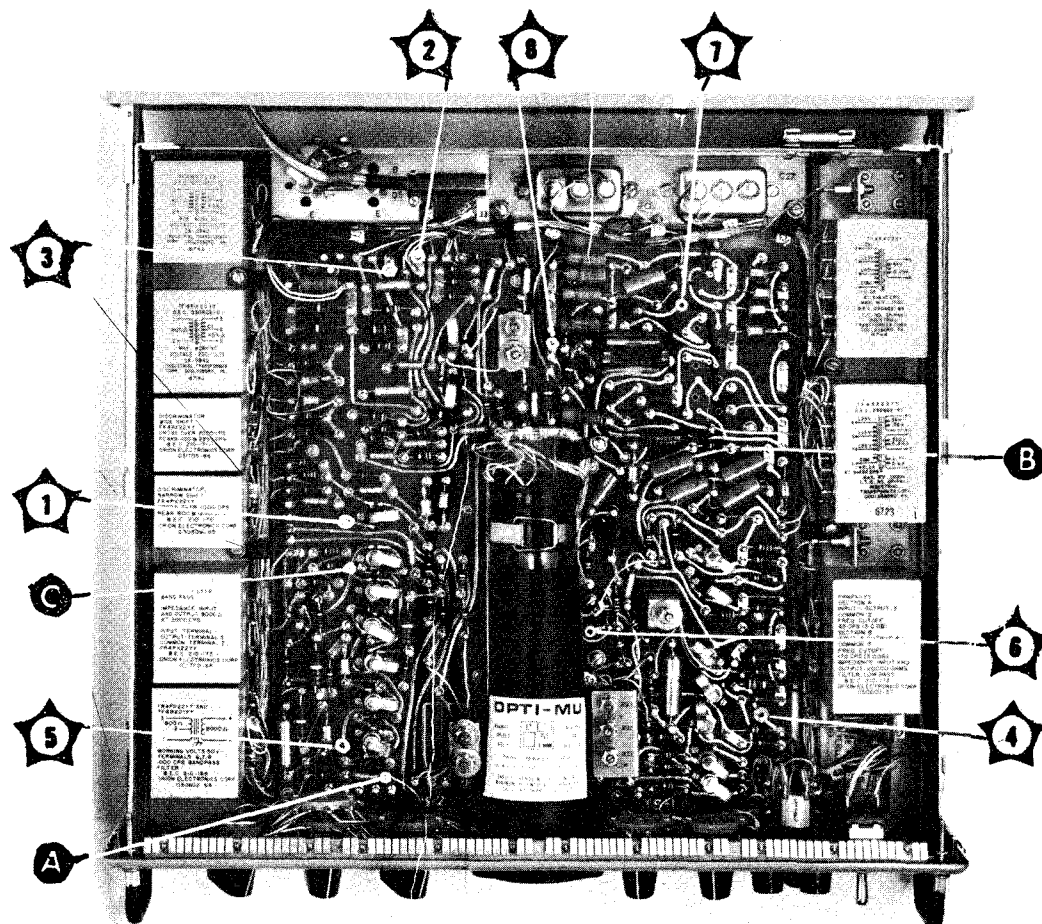





Figure 5-2. Frequency Shift Converter CV-483C/URA-17, Location of Test Points

TABLE 5-2. FREQUENCY SHIFT CONVERTER CV-483C/URA-17,
SIGNAL PROCESSING CIRCUITS FUNCTIONAL SECTION
TROUBLE-SHOOTING CHART

STEP	TEST POINT	PRELIMINARY ACTION	NORMAL INDICATION	NEXT STEP
1		Connect fsk receiver audio output to AUDIO INPUT jack (J2) at rear of converter. Adjust receiver and converter controls for single-receiver operation (Section 3, paragraph 3-2g(1), steps 1 through 10).	Tuning indicator pattern as (A) in figure 3-2.	<p>(1) If pattern shifts unevenly above and below center line of crt bezel: recheck receiver tuning. If receiver tuning is ok, proceed to table 5-4, step 2; check Q2, Q3, Q4, and Q5 (figure 6-3); measure dc voltages on Q2, Q3, Q4, and Q5 terminals (figure 5-3); measure resistances of T1 and T2 windings (figures 5-1 and 6-2); check CR3, CR4, CR5, and CR6 (figure 6-3); measure resistances of R25 and R26 (figure 6-3); realign mark-space amplifiers (Section 6, paragraph 6-2h).</p> <p>(2) If pattern shifts up only: recheck receiver tuning. If receiver tuning is ok, proceed to table 5-4, step 2; check Q3 and Q5 (figure 6-3); measure dc voltages on Q3 and Q5 terminals (figure 5-3); measure resistances of T2 windings (figures 5-1 and 6-2); measure resistance of R26 (figure 6-3); check CR5 and CR6 (figure 6-3).</p> <p>(3) If pattern shifts down only: recheck receiver tuning. If receiver tuning is ok, proceed to table 5-4, step 2; check Q2 and Q4 (figure 6-3); measure dc voltages on terminals of Q2 and Q4 (figure 5-3); measure resistances of T1 windings (figures 5-1 and 6-2); measure resistance of R25 (figure 6-3); check CR3 and CR4 (figure 6-3).</p> <p>(4) If pattern's vertical amplitude is very small or zero: check LEVEL control setting. If LEVEL control setting is ok, proceed to table 5-4, step 2; check Q1 through Q10 (figures 6-3 and 6-4); measure dc voltages on terminals of Q1 through Q10 (figure 5-3). Realign dc amplifier (Section 6, paragraph 6-2i). If upon completion of dc amplifier alignment the trouble still persists, proceed to step 2.</p>

TABLE 5-2. FREQUENCY SHIFT CONVERTER CV-483C/URA-17,
SIGNAL PROCESSING CIRCUITS FUNCTIONAL SECTION
TROUBLE-SHOOTING CHART (Continued)

STEP	TEST POINT	PRELIMINARY ACTION	NORMAL INDICATION	NEXT STEP
2	 (Figures 5-2 and 5-4)	Set up oscilloscope to display low frequency signals. Connect oscilloscope ground terminal to converter chassis. Touch vertical input lead to TP-1.	Pattern as in step 2 of table 5-5.	If ok, proceed to step 3. If not, check Q1 (figure 6-3); measure dc voltages on terminals of Q1 (figure 5-3).
3	 (Figures 5-2 and 5-4)	Touch oscilloscope vertical input lead to TP-2.	Pattern as in step 3 of table 5-5.	If ok, proceed to step 4. If not, check Q2 and Q4 (figure 6-3); measure dc voltages on terminals of Q2 and Q4 (figure 5-3).
4	 (Figures 5-2 and 5-4)	Touch oscilloscope vertical input lead to TP-3.	Pattern as in step 4 of table 5-5.	If ok, proceed to step 5. If not, check Q3 and Q5 (figure 6-3); measure dc voltage on terminals of Q3 and Q5 (figure 5-3).
5	 (Figures 5-2 and 5-4)	Touch oscilloscope vertical input lead to TP-4.	Pattern as in step 5 of table 5-5.	If not similar, check Q6, Q7, Q8, Q9, and Q10 (figure 6-4); measure dc voltages on terminals of Q6, Q7, Q8, Q9, and Q10 (figure 5-3).

(b) SPECIAL TOOLS. - No special tools will be required.

(3) CONTROL SETTINGS. - The control settings for the converter during functional trouble-shooting of the keyer circuits are the same as the control settings for overall trouble-shooting (refer to paragraph 5-3c).

(4) ILLUSTRATIONS.

(a) TEST POINTS. - Figure 5-2 illustrates the physical locations of all test points to be used in functional section trouble-shooting.

(b) SCHEMATIC DIAGRAMS. - Figure 5-6 is the schematic diagram of the keyer circuits.

(c) VOLTAGE AND RESISTANCE DIAGRAM. - Figure 5-5 lists voltages and resistances measured from the terminals of the transistors in the keyer circuits to the converter chassis, with no signal applied.

(d) SIGNAL TRACING OSCILLOSCOPE PATTERNS. - Table 5-5 illustrates oscilloscope patterns to be used as guides during signal tracing.

(e) ALIGNMENT OF THE CONVERTER AFTER TROUBLE-SHOOTING. - After trouble-shooting the keyer circuits, if repairs or component changes were made, refer to Section 6, paragraph 6-2, for alignment procedures. Table 6-1 lists adjustments required after specific transistors are replaced or values in the circuits of these transistors are changed.

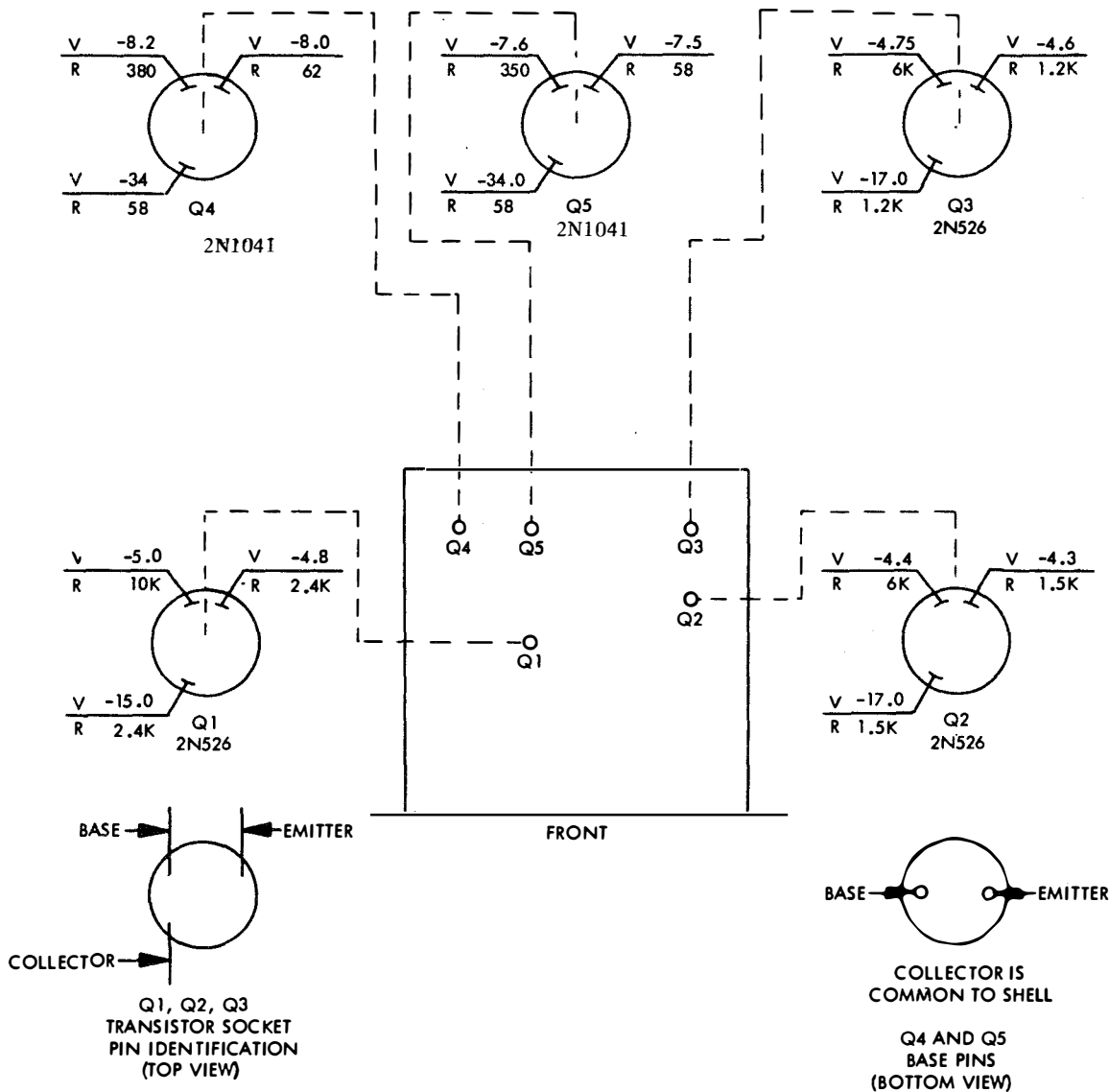

NOTES:

V INDICATES DC VOLTAGE TO CHASSIS WITH VT VM (NO SIGNAL).
R INDICATES RESISTANCE (IN OHMS) TO CHASSIS WITH POWER SWITCH OFF.

Figure 5-3. Frequency Shift Converter CV-483C/URA-17, Signal Processing Circuits,
Voltage and Resistance Measurements

d. POWER SUPPLIES TROUBLE-SHOOTING.

(1) PRELIMINARY CHECK. - The preliminary check for functional trouble-shooting the power supplies is the same as the preliminary check for overall trouble-shooting (refer to paragraph 5-3a).

(2) TEST EQUIPMENT AND SPECIAL TOOLS.

(a) TEST EQUIPMENT. - The following test equipment will be required:

AN/PSM-4 Multimeter
ME-30/U ac vtvm
TS-1100/U test set, transistor

(b) SPECIAL TOOLS. - No special tools will be required.

(3) CONTROL SETTINGS. - The control setting for the converter during functional trouble-shooting of the power supplies are the same as the control settings for overall trouble-shooting (refer to paragraph 5-3c).

TABLE 5-3. FREQUENCY SHIFT CONVERTER CV-483C/URA-17,
KEYER CIRCUITS FUNCTIONAL SECTION
TROUBLE-SHOOTING CHART

STEP	TEST POINT	PRELIMINARY ACTION	NORMAL INDICATION	NEXT STEP
1		Connect fsk receiver audio output to AUDIO INPUT jack (J2) at rear of converter. Connect teletype printer to TTY OUTPUT jack (J6) at rear of converter. Adjust receiver and converter controls for single-receiver operation (Section 3, paragraph 3-2g(1)).	Teletype printer prints readable copy.	<p>If teletype printer is locked up: check Q11 through Q18 (figures 6-3 and 6-4); measure dc voltages on terminals of Q11 through Q18 (figure 5-5).</p> <p>If teletype printer runs open: check Q13 through Q18 (figure 6-3); measure dc voltages on terminals of Q13 through Q18 (figure 5-5).</p> <p>If trouble still persists, proceed to step 2.</p>
2	 (Figures 5-2 and 5-6)	<p>Set up oscilloscope to display low frequency signals. Connect oscilloscope ground terminal to converter chassis.</p> <p>Touch vertical input lead to TP-5.</p>	<p>Pattern as in step 6 of table 5-5.</p>	<p>If ok, measure resistance of R67 (figure 6-3); check CR20 (figure 6-3).</p> <p>If pattern is not ok: check Q13 through Q16 (figure 6-3); measure dc voltages on terminals of Q13 through Q16 (figure 5-5).</p>

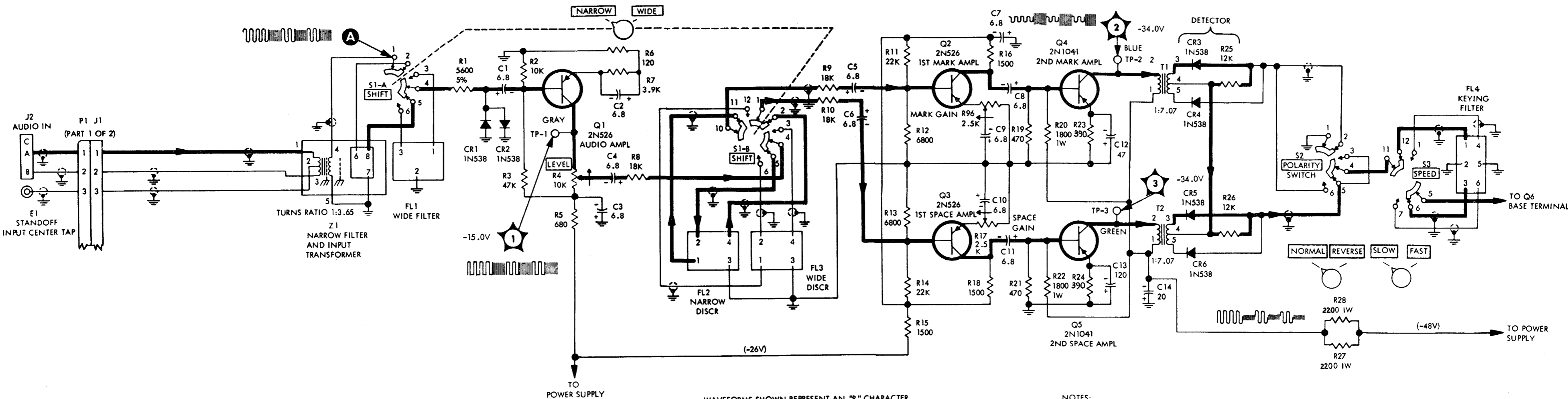

WAVEFORMS SHOWN REPRESENT AN "R" CHARACTER REPEATED CONTINUOUSLY AS RECEIVED FROM A TAPE FED TRANSMITTER AND DISPLAYED ON AN OSCILLOSCOPE WHOSE SWEEP IS OPERATING AT THE CHARACTER REPETITION RATE. WHEN SWEEP IS NOT IN SYNC WITH CHARACTER REPETITION RATE, OR WHEN MIXED CHARACTERS ARE RECEIVED, A DISTINCT WAVEFORM WILL NOT BE SHOWN BUT VARIOUS COMBINATIONS OF MOVING CHARACTERS WILL NORMALLY BE DISPLAYED.

NOTES:

1. UNLESS OTHERWISE SPECIFIED:
ALL CAPACITORS ARE IN UF
ALL RESISTORS ARE IN OHMS
ALL RESISTORS 1/2 WATT 10%
K = 1000 MEG = 1,000,000
2. UNLESS OTHERWISE INDICATED,
ALL VOLTAGES TAKEN TO CHASSIS
WITH 20,000 OHM/VOLT VOLTMETER,
WITH NO INPUT SIGNAL
3. ALL VOLTAGES ARE DC
4. ALL ROTARY SWITCHES SHOWN
IN FULLY CCW POSITIONS UNLESS
OTHERWISE SPECIFIED
5. INDICATES FRONT PANEL
CONTROL
6. ARROWS ON VARIABLE RESISTORS
INDICATE CLOCKWISE ROTATION.
7. REFER TO FIGURE 6-2 FOR
TRANSFORMER AND FILTER
RESISTANCES.

Figure 5-4. Frequency Shift Converter CV-483C/URA-17,
Signal Processing Circuits. Functional Schematic Diagram

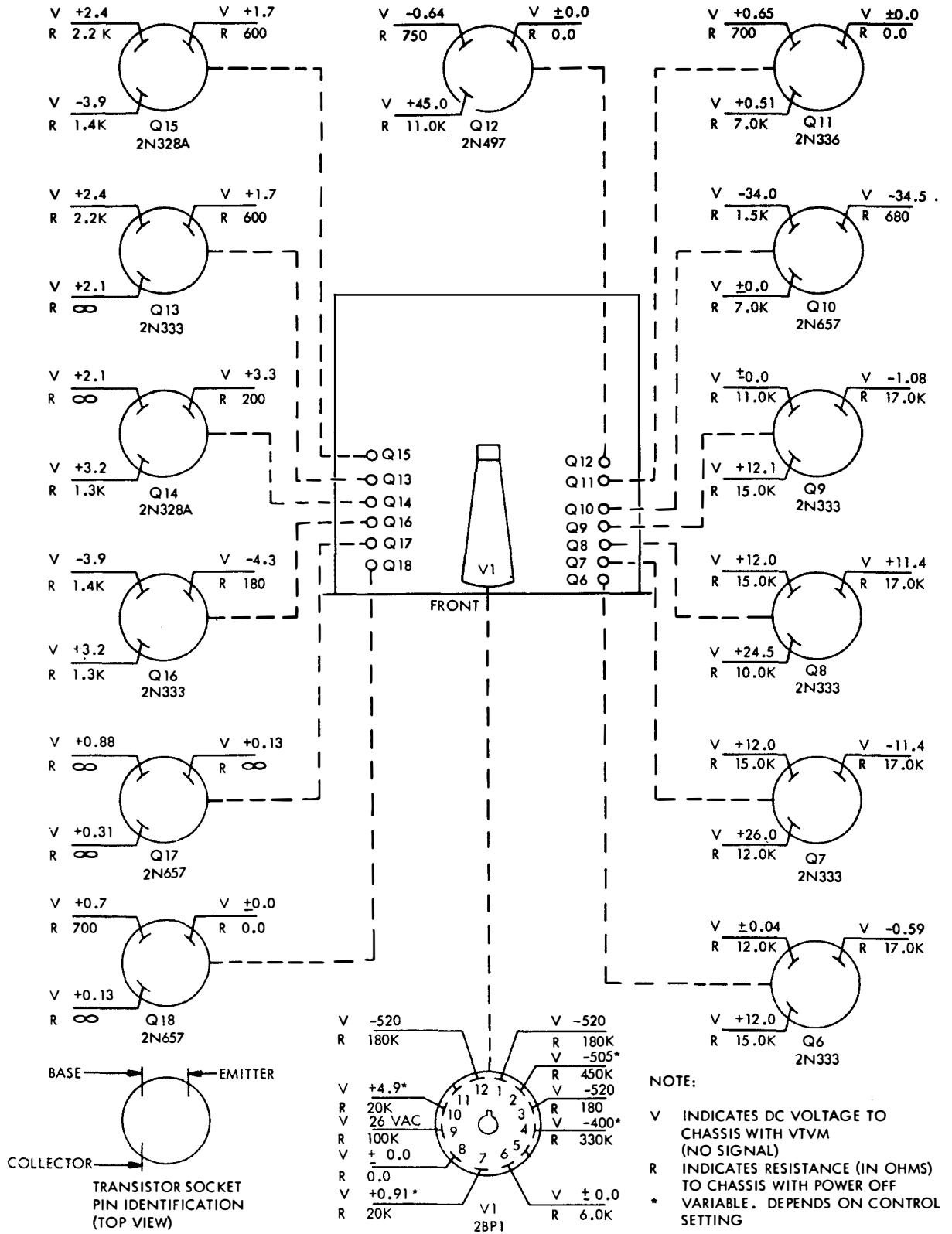

Figure 5-5. Frequency Shift Converter CV-483C/URA-17, Keyer Circuits, Voltage and Resistance Measurements

TABLE 5-4. FREQUENCY SHIFT CONVERTER CV-483C/URA-17,
POWER SUPPLIES FUNCTIONAL SECTION
TROUBLE-SHOOTING CHART

STEP	TEST POINT	PRELIMINARY ACTION	NORMAL INDICATION	NEXT STEP
1		Turn converter POWER switch to On.	Indicator lamp glows.	If lamp glows, proceed to step 2. If lamp does not glow: (1) Check indicator lamp (paragraph 3-4d). (2) Check fuses F1 and F2 on front panel (refer to paragraph 3-4e). (3) Check that chassis is fully closed (table 3-3). If ok, loosen the captive screw at each corner of front panel, pull chassis forward to stops, and check interlock switches S5A and S5B (figure 2-10). (4) Check that chassis plug P1 (figure 6-3) and POWER plug (on rear of cabinet) are properly connected to mating receptacles. (5) Check line voltage source. (6) Check POWER switch (figure 3-1).
2	6 (Figures 5-2 and 5-8)	Turn converter POWER switch to Off. Adjust multimeter to measure -560 volts dc. Connect positive lead of multimeter to converter chassis. Connect negative lead of multimeter to TP-6. Turn converter POWER switch to On.	-560 volts $\pm 10\%$	If ok, continue with step 2. If not, check CR32 and CR33 (figure 6-4); measure R84 (figure 6-4).
3	7 (Figures 5-2 and 5-8)	Adjust multimeter to measure -48 volts dc. Connect positive lead of multimeter to converter chassis. Connect negative lead of multimeter to TP-7.	-48 volts $\pm 10\%$	If ok, continue with step 3. If not, adjust -48 ADJ control R72 (figure 5-1) as required; check Q19, Q23, and Q24 (figure 6-4); measure dc voltages at terminals of Q19, Q23, and Q24 (figures 5-7 and 6-4)
4	8 (Figures 5-2 and 5-8)	Adjust multimeter to measure +48 volts dc. Connect negative lead of multimeter to converter chassis. Connect positive lead of multimeter to TP-8.	+48 volts $\pm 10\%$	If incorrect, adjust +48 ADJ control R89 (figure 5-1) as required; check Q20, Q21, and Q22 (figure 6-4); measure dc voltages at terminals of Q20, Q21, and Q22 (figures 5-7 and 6-4). If, upon completion of the trouble-shooting procedure given in this task, the tuning indicator pattern is not as (A) in figure 3-2, proceed to table 5-2 and applicable step.

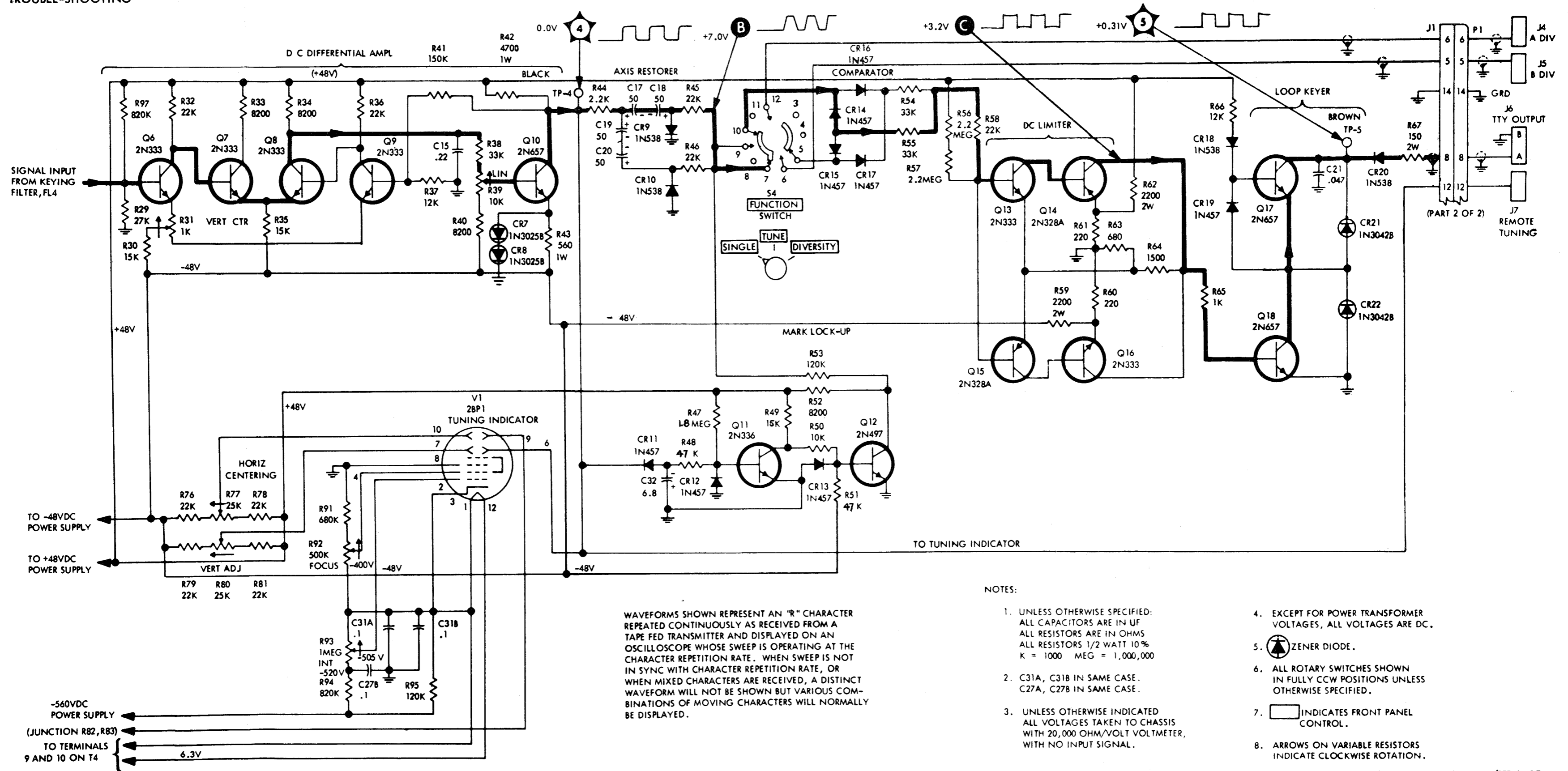

Figure 5-6. Frequency Shift Converter CV-483C/URA-17, Keyer Circuits, Functional Schematic Diagram

(4) ILLUSTRATIONS.

(a) TEST POINTS. - Figure 5-2 illustrates the physical locations of all test points to be used in functional section trouble-shooting.

(b) SCHEMATIC DIAGRAMS. - Figure 5-8 is the schematic diagram of the power supplies. Figure 5-7 is the primary power distribution diagram.

5-5. TYPICAL TROUBLES.

Table 5-6 lists typical troubles that may occur during the service life of the AN/URA-17C.

5-6. LOCATION OF PARTS.

Figures 6-3 and 6-4 illustrate the location of all circuit elements that may require replacement during the service life of the AN/URA-17C.

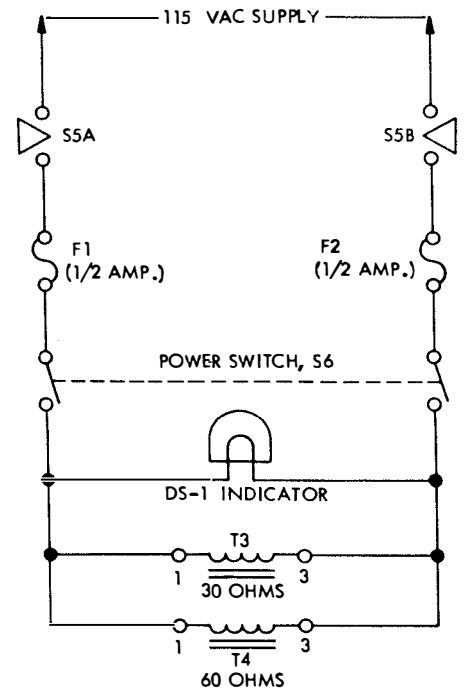







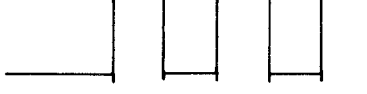
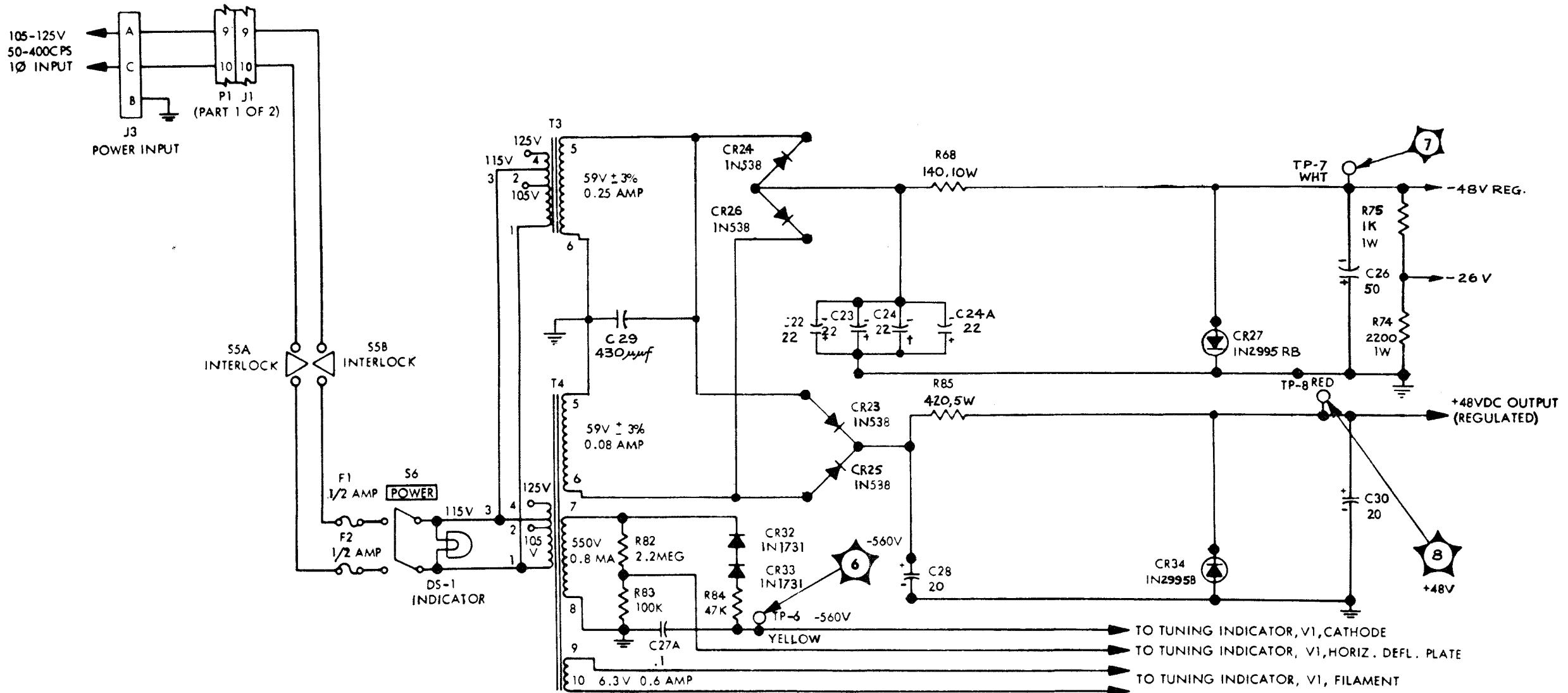

Figure 5-7. Frequency Shift Converter
CV-483C/URA-17, Primary Power
Distribution Diagram

TABLE 5-5. SIGNAL TRACING OSCILLOSCOPE PATTERNS*

STEP	TEST POINT	WAVEFORM	NOTES
1	A (figure 5-2)		Terminal 1 of S1-A (figure 6-3)
2	1 (figure 5-2)		
3	2 (figure 5-2)		
4	3 (figure 5-2)		
5	4 (figure 5-2)		
6	5 (figure 5-2)		
7	B (figure 5-2)		Junction of R45 and R46 (figure 6-4)
8	C (figure 5-2)		Collector terminals of Q14 and Q16 (figure 6-3)

* Waveforms shown represent reception of an "R" character repeated continuously by a tape-fed transmitter and displayed on an oscilloscope whose sweep is operating at the character repetition rate. When receiving mixed characters or the sweep is not in sync with the character repetition rate, various moving characters will normally be displayed.



NOTES:



1. UNLESS OTHERWISE SPECIFIED:
ALL CAPACITORS ARE IN UF
ALL RESISTORS ARE IN OHMS
ALL RESISTORS 1/2 WATT 10 %
K=1000 MEG= 1,000,000
2. UNLESS OTHERWISE INDICATED:
ALL VOLTAGES TAKEN TO CHASSIS
WITH 20,000 OHM/VOLT VOLTMETER,
WITH NO INPUT SIGNAL.
3. EXCEPT FOR POWER TRANSFORMER
VOLTAGES, ALL VOLTAGES ARE DC.
4.  ZENER DIODE
5.  INDICATES FRONT PANEL CONTROL.

Figure 5-8. Frequency Shift Converter CV483C/URA-17,
Power Supplies, Functional Schematic Diagram

TABLE 5-6. FREQUENCY SHIFT CONVERTER CV-483C/URA-17,
TYPICAL TROUBLES

TROUBLE	NATURE OF TROUBLE	SYMPTOMS
Teletype printer runs open.	Fuses blown (F1 or F2, on front panel of converter). Ac power not on. Defective connection on power input cable. Defective POWER input receptacle (on rear of converter cabinet). Safety interlock switches open or defective (figure 2-10).	Indicator light out when POWER switch is On; no pattern on tuning indicator.
	Receiver detuned. Receiver output connection defective. Defective converter.	Indicator light is on but no pattern on tuning indicator.
	Teletype printer loop power supply defective. Loop keyer or dc limiter in converter defective.	Tuning indicator pattern normal, but teletype printer runs open.
Teletype printer locked up.	FUNCTION switch on converter left in TUNE position.	Tuning indicator pattern normal; teletype printer locked up.
Teletype printer prints garbled copy.	Receiver not properly tuned.	Tuning indicator pattern not centered vertically.
	POLARITY switch on converter in wrong position.	Tuning indicator pattern normal, teletype printer prints garbled copy.

SECTION 6 REPAIR

6-1. FAILURE REPORT.

FAILURE REPORT

'Report each failure of the equipment, whether caused by a defective part, wear, improper operation, or an external cause. Use ELECTRONIC FAILURE REPORT form DD787. Each pad of the forms includes full instructions for filling out the forms and forwarding them to the Naval Electronic Systems Command. However, the importance of providing complete information cannot be emphasized too much. Be sure that you include the model designation and serial number of the equipment (from the equipment identification plate), the type number and serial number of the major unit (from the major unit identification plate), and the type number and reference designation of the particular defective part (from the technical manual). Describe the cause of the failure completely, continuing on the back of the form if necessary. Do not substitute brevity for clarity. And remember--there are two side to the failure report.--

'YOUR SIDE'

'Every FAILURE REPORT is a boost for you:

1. It shows that you are doing your job.
2. It helps make your job easier.
3. It insures available replacements.
4. It gives you a chance to pass your knowledge to every man on the team.

'COMMAND SIDE'

'The Electronic Systems Command uses the information to:

1. Evaluate present equipment.
2. Improve future equipment.
3. Order replacements for stock.
4. Prepare field changes.
5. Publish maintenance data.

Always keep a supply of failure report forms on board. You can get them from the nearest District Publications and Printing Office.'

6-2. TUNING AND ADJUSTMENT.

a. GENERAL. - Reference to this section is usually made after completion of trouble-shooting procedures in Section 5. If the defective part has been found, but the method of replacement is not easily determined, refer to paragraph 6-3. Table 6-1 lists adjustments required after replacing specific transistors (or components in these transistor circuits). Tests of filter characteristics are given in paragraph 6-3d(5), and tests of discriminator

characteristics are given in paragraph 6-3d(6).

The following procedures provide the required alignment for the converters. Each procedure is complete. If two or more procedures are to be performed, reading ahead can prevent duplicating steps.

WARNING

Dangerous voltages exist within the converter when connected to the line voltage source, even when the POWER switch is in the Off position.

b. STANDARDS. - Maintenance Standards Book NAVSHIPS 0967-034-9030 contains a series of maintenance standard test procedures which provide indications representing optimum equipment performance, and a series of preventative maintenance procedures. Performance Standard Sheet NAVSHIPS 0967-034-9020 lists minimum acceptable limits for overall performance of the equipment.

c. TEST EQUIPMENT AND SPECIAL TOOLS. - The following test equipment, or the equivalent (refer to table 1-3), will be required. No special tools will be required.

ME-30/U	vtvm (two required)
TS-382/U	audio oscillator
AN/TSM-9	frequency meter
AN/PSM-4	multimeter

d. SPECIAL JIGS. - No special jigs, fixtures, etc., will be required.

e. CONTROL SETTINGS. - Set the converter POWER switch to the Off position. The other converter controls will be set during the respective adjustment or alignment procedures.

f. POWER SUPPLY ADJUSTMENTS.

(1) +48 VOLT SUPPLY.

- Step 1. Withdraw chassis to stops on drawer slides, and operate interlock switches (figure 2-10) by pressing in on button at left side of switch block.
- Step 2. Connect negative lead from multimeter to chassis, and positive lead to red test point, TP- ★ 8 (figure 5-2).
- Step 3. Adjust multimeter to appropriate dc voltage scale.
- Step 4. Turn converter POWER switch to On and

- allow five minute warm-up period
- Step 5. Check for multimeter indication of +48 volts.
- Step 6. Turn POWER switch to Off and disconnect multimeter leads from converter.
- (2) -48 VOLT SUPPLY.
- Step 1. Withdraw chassis to stops on drawer slides, and operate interlock switches (figure 2-10) by pressing in on button at left side of switch block.
- Step 2. Connect positive lead from multimeter to converter chassis, and negative lead to white test point, TP- ★ 7 (figure 5-2).
- Step 3. Adjust multimeter to appropriate dc voltage scale.
- Step 4. Turn converter POWER switch to On and allow five minute warm-up period.
- Step 5. Check for multimeter indication of -48 volts.
- Step 6. Turn POWER switch to Off and disconnect multimeter leads from converter.

g. CATHODE-RAY TUBE ADJUSTMENTS.

- Step 1. Withdraw chassis to stops on drawer slides, and operate interlock switches (figure 2-10) by pressing in on button at left side of switch block.
- Step 2. Turn converter POWER switch to On position and allow five minute warm-up period.
- Step 3. Adjust FOCUS control, R92, and INT (intensity) control, R93 (figure 2-10), for normal operation.
- Step 4. Short black test point, TP- ★ 4 (figure 5-2), to converter chassis with a clip lead.
- Step 5. Adjust VERT ADJ control, R80 (figure 5-1), to center trace on crt bezel.
- Step 6. Adjust HORIZ CENTERING control, R77 (figure 5-1), to center trace on crt bezel.
- Step 7. If trace on crt bezel is not horizontal, loosen the screw in clamp at crt base (figure 5-1), and rotate crt until trace is horizontal. Tighten screw in crt clamp.
- Step 8. Turn POWER switch to Off and remove clip lead from TP- ★ 4.

h. MARK AND SPACE GAIN CONTROL ADJUSTMENTS.

- Step 1. Withdraw chassis to stops on drawer slides, and operate interlock switches (figure 2-10) by pressing in on button at left side of switch block.
- Step 2. Connect vtm's and audio oscillator to power source and turn power switches on. Allow at least five minute warm-up period.
- Step 3. Adjust converter LEVEL control to 6, set SHIFT switch to NARROW and SPEED switch to SLOW. Turn POWER switch to On position and allow five minute warm-up period.
- Step 4. Disconnect cable from AUDIO INPUT connector, J2, on rear of converter cabinet.
- Step 5. Adjust audio oscillator frequency to 1000 cps.
- Step 6. Set vtm range switch to 10 volts and connect to audio oscillator output terminals.
- Step 7. Connect audio oscillator output terminals to AUDIO INPUT connector, J2, on rear of converter cabinet or to terminals 1 and 3 of Z1 (figure 5-1). Adjust audio oscillator for output of 6.0 volts as measured on vtm. Leave vtm connected to audio oscillator terminals.
- Step 8. Set range switch of second vtm to 1 volt and connect between terminal 1 of FL2 (figure 5-1) and converter chassis. Record vtm indication.
- Step 9. Move vtm lead from terminal 1 of FL2 to terminal 4 of FL2. Adjust vtm range switch as required. Record vtm indication.
- Step 10. Adjust audio oscillator frequency and repeat steps 8 and 9 until voltages at terminals 1 and 4 of FL2 are equal. Maintain constant audio oscillator output voltage.
- Step 11. Move vtm lead from terminal 1 or 4 of FL2 to green test point, TP- ★ 3 (figure 5-2). Adjust SPACE GAIN control, R17 (figure 5-1), for 4.0 volt vtm indication.
- Step 12. Move vtm lead from green test point, TP- ★ 3, to blue test point, TP- ★ 2 (figure 5-2), and adjust MARK GAIN control, R96 (figure 5-1), for 4.0 volt vtm indication.
- Step 13. Repeat steps 11 and 12 until 4.0 volt indications are obtained at TP- ★ 2 and TP- ★ 3.
- Step 14. Turn POWER switch to Off and disconnect audio oscillator and vtm from converter. Re-

connect cable removed from AUDIO INPUT connector, J2, on rear of converter cabinet.

Return multimeter range switch to 40 volt dc scale.

i. DC DIFFERENTIAL AMPLIFIER ADJUSTMENTS.

- Step 1. Withdraw chassis to stops on drawer slides, and operate interlock switches (figure 2-10) by pressing in on button at left side of switch block.
- Step 2. Connect vtm and audio oscillator to power source and turn power switches on. Allow at least five minute warm-up period.
- Step 3. Turn converter POWER switch to On and allow five minute warm-up period.
- Step 4. Disconnect cable from AUDIO INPUT connector, J2, at rear of converter cabinet.
- Step 5. Adjust converter LEVEL control to 0, and set POLARITY switch to NORMAL.
- Step 6. Adjust multimeter to 40 volt dc scale.
- Step 7. Connect negative lead from multimeter to converter chassis and positive lead to black test point, TP- ★ 4 (figure 5-2).
- Step 8. Adjust VERT CTR control, R31 (figure 2-10), for a zero indication on multimeter. Change multimeter range switch as required to obtain exact setting for R31.
- Step 9. Adjust audio oscillator for an output of 2650 cps.
- Step 10. Set vtm range switch to 10 volts and connect to audio oscillator output terminals.
- Step 11. Connect audio oscillator output terminals to AUDIO INPUT connector, J2, on rear of converter cabinet or to terminals 1 and 3 of Z1 (figure 5-1). Adjust audio oscillator for 6.0 volt indication on vtm. Leave vtm connected to audio oscillator.
- Step 12. Adjust multimeter to 40 volt dc scale.
- Step 13. Adjust converter LEVEL control to 6.
- Step 14. Adjust LIN (linearity) control, R39 (figure 5-1), for multimeter indication of +32 volts (at TP- ★ 4).
- Step 15. Adjust audio oscillator output to zero, set converter LEVEL control to 0, and adjust VERT CTR control, R31 (figure 5-1), for zero multimeter indication. Adjust multimeter range switch as required

- Step 16. Set converter LEVEL control to 6 and adjust audio oscillator output to 6.0 volts as measured by vtm.
- Step 17. Adjust converter LIN (linearity) control, R39 (figure 5-1), for equal positive and negative voltages on multimeter as converter POLARITY switch is changed from NORMAL to REVERSE.
- Step 18. Adjust audio oscillator output to zero, set converter LEVEL control to 0, and adjust VERT CTR control, R31 (figure 2-10), for zero multimeter indication.
- Step 19. Turn POWER switch to Off and disconnect test equipment from converter. Reconnect cable removed from AUDIO INPUT connector, J2, on rear of converter cabinet.

6-3. REMOVAL, ADJUSTMENT, REPAIR, AND RE-ASSEMBLY.

a. GENERAL. - All electrical components of the converter are installed on two printed circuit boards or the surrounding metal frame. See figures 5-1, 6-3, and 6-4 for locations of component parts.

CAUTION

Most of these components are small and a heat sink must be used when soldering or unsoldering them. Be sure all loose solder and bits of wire are removed before power is applied.

b. ILLUSTRATIONS.

(1) PHOTOGRAPHS. - Figure 5-1 illustrates the physical locations of all parts in the converter that may require replacement during the normal service life of the AN/URA-17C. Figure 5-2 illustrates the physical location of all test points in the converter.

(2) WIRING DIAGRAMS. - Figures 6-3 and 6-4 are wiring diagrams of the converter.

c. REMOVAL AND REASSEMBLY. - Removal and reassembly instructions are given in the following paragraphs.

(1) CHASSIS REMOVAL. - To remove converter chassis from cabinet, proceed as follows:

- Step 1. Loosen four captive screws on front panel, one at each corner.

- Step 2. Pull converter chassis forward until drawer slides lock.
- Step 3. Remove main cable plug, P1, from J1 at rear of chassis (figure 5-1), and remove cable from clamp near J1.
- Step 4. Lift latch on bottom near front of each drawer slide, grasp both sides of converter chassis, and pull forward until chassis is free of cabinet drawer slides. To replace chassis, reverse this procedure.

(2) TRANSFORMER AND FILTER REPLACEMENT. - The transformers and filters are bolted to the metal frame around the printed circuit boards (figure 5-1). Remove the securing nuts and washers beneath the frame, tag and unsolder connecting wires, and lift transformer or filter straight upward. Replace by reversing this procedure.

(3) PRINTED CIRCUIT BOARD REPLACEMENT. There are two printed circuit boards (figure 5-1) used in the converter. Remove either of them as follows:

- Step 1. Tag for identification and unsolder leads to terminals on printed circuit board.
- Step 2. Remove securing screws holding printed circuit board to metal frame and remove board. To replace printed circuit board, reverse this procedure.

(4) RECEPTACLE PANEL REMOVAL. - To remove receptacle panel at rear of converter (figure 2-6), loosen the captive screw at each corner of receptacle panel and pull panel from cabinet.

d. ADJUSTMENT AND REPAIR.

(1) TEST EQUIPMENT AND SPECIAL TOOLS. Refer to paragraph 6-2c.

(2) TRANSISTOR REPLACEMENT. - All transistors are mounted in sockets, with clamps holding them in place. The transistors are easily removed by pulling clamps away from the transistors.

NOTE

Pins on replacement transistors must be cut to $13/64 + 1/64$ inch. Do not force transistors into sockets. Bending of pins may crack the seal. Never attempt to solder or otherwise apply heat to transistor pins.

(3) TUNING INDICATOR CATHODE-RAY TUBE REPLACEMENT. - Replace the tuning indicator crt as follows:

- Step 1. Pull chassis forward on drawer slides.
- Step 2. Remove socket from tube base.
- Step 3. Loosen screws that hold hood and window assembly in front of tube face and remove the assembly.
- Step 4. Loosen screw in clamp at tube base.
- Step 5. Remove tube and shield. Install new tube in shield (tube socket key way up). Install tube and shield behind chassis opening. Replace tube socket, front hood, and window assembly. Push tube forward against hood assembly and tighten clamp.
- Step 6. Perform cathode-ray tube adjustments in paragraph 6-2g.

(4) TRANSISTOR SOCKET REPLACEMENT. Transistor sockets are attached to the printed circuit boards by screws. Remove the $3/32$ inch lock nuts from below socket, unsolder socket terminals from printed circuit board, and lift off socket. To reinstall, position socket and check that socket terminals line up properly with printed circuit leads. Then replace the screws and lock nuts and solder socket terminals to printed circuit leads.

(5) ROTARY SWITCH REPAIRS.

(a) REPLACING DEFECTIVE SWITCH WAFER. - Replace defective switch wafer as follows:

- Step 1. Remove nuts and washers from rear (chassis side) of switch.
- Step 2. Slip defective wafer from switch shaft.

NOTE

SHIFT switch (S1 A-B) has two switch wafers. If front wafer is defective, remove rear wafer, spacers between wafers, and the defective wafer. Pay close attention to position of wafers on switch shaft.

- Step 3. Place new wafer on switch shaft. Be sure wafer is correctly positioned.
- Step 4. Replace removed hardware (nuts, lock washers, and spacers) if applicable.
- Step 5. Unsolder wires (one at a time) from defective wafer and solder to replacement wafer. Be very careful that wires are correctly placed and mechanically secure before soldering.

(b) REPLACING DEFECTIVE SWITCH. - If defect is other than switch wafer, replace entire switch as follows:

- Step 1. Loosen set-screw in front panel knob and remove knob.
- Step 2. Remove securing nut and lock washer from switch shaft.
- Step 3. Tag and identify wires on switch terminals.
- Step 4. Unsolder wires from defective switch.
- Step 5. Push switch back, through front panel hole.
- Step 6. Solder wires to new switch, being sure wires are correctly placed and mechanically secure before soldering to new switch terminals.
- Step 7. Place switch in position, add securint nut, lock washer, and knob.

(6) BANDPASS FILTER TESTS. - Table 6-2 lists characteristics of bandpass filters FL1 and Z1. Resistance information is given in figure 6-2. Perform the following procedures to check characteristics of bandpass filters. Replace any filter not passing applicable tests.

(a) WIRE-SHIFT FILTER FL1.

- Step 1. Withdraw chassis to stops on drawer slides, and operate interlock switches (figure 2-10) by pressing in on button at left side of switch block.
- Step 2. Connect vtm's, audio oscillator, and frequency meter to power source and turn power switches on. Allow at least 15 minutes warm-up for frequency meter.
- Step 3. Set converter SHIFT switch to WIDE, and turn POWER switch to On position. Allow five minute warm-up period.
- Step 4. Disconnect cable from AUDIO INPUT connector, J2, at rear of converter cabinet.
- Step 5. Connect audio oscillator input terminals to AUDIO INPUT connector, J2, or to terminals 1 and 3 of Z1 (figure 5-1).
- Step 6. Set audio oscillator to 2000 cps, measured with frequency meter.
- Step 7. Set vtm range switch to 10 volts and connect between gray test point TP- ★ 1 (figure 5-2) and converter chassis.

- Step 8. Adjust audio oscillator output to obtain vtm indication of 5.0 volts.
- Step 9. Set range switch to second vtm to 10volts and connect to audio oscillator output terminals.
- Step 10. Decrease audio oscillator frequency until vtm connected to TP- ★ 1 indicates 2.5 volts, keeping audio oscillator output voltage constant. Record audio oscillator frequency. Increase frequency until vtm connected to TP- ★ 1 indicates 2.5 volts, keeping audio oscillator output voltage constant. Subtract lower frequency from higher frequency. Result must be 2100 cps +150 cps.
- Step 11. Increase audio oscillator frequency until vtm connected to TP- ★ 1 indicates 0.05 volts, keeping audio oscillator output voltage constant. Record audio oscillator frequency. Decrease frequency until vtm connected to TP- ★ 1 indicates 0.05 volt, keeping audio oscillator output voltage constant. Subtract lower frequency from higher frequency. Result must be 3100 cps +200 cps.
- Step 12. Turn POWER switch to Off and disconnect vtm and audio oscillator from converter. Reconnect cable to AUDIO INPUT connector, J2, on rear of converter cabinet.

(b) NARROW-SHIFT FILTER (PART OF

- Z1).
- Step 1. Withdraw chassis to stops on drawer slides, and operate interlock switches (figure 2-10) by pressing in on button at left side of switch block.
- Step 2. Connect vtm's, audio oscillator, and frequency meter to power source and turn power switches on. Allow at least 15 minutes warm-up for frequency meter.
- Step 3. Set converter SHIFT switch to NARROW, and turn POWER switch to On position. Allow five minute warm-up period.
- Step 4. Remove cable attached to AUDIO INPUT connector, J2, at rear of converter cabinet.
- Step 5. Connect audio oscillator output terminals to AUDIO INPUT connector, J2, or to terminals 1 and 3 of Z1 (figure 5-1).
- Step 6. Set audio oscillator to 1000 cps, using frequency meter.

- Step 7. Set vtm range switch to 10 volts and connect between gray test point, TP ★ 1 (Figure 5-2) and converter chassis. Record vtm indication.
- Step 8. Adjust audio oscillator output to obtain vtm indication of 5.0 volts. Step 10. Decrease audio oscillator frequency until vtm connected to TP ★ 1 indicates 2.5 volts, keeping audio oscillator output voltage constant. Record audio oscillator frequency. Increase audio oscillator frequency until vtm connected to TP- ★ 1 indicates 2.5 volts, keeping audio oscillator output voltage constant. Subtract
- Step 9. Set range switch of second vtm to 10 volts and connect to audio oscillator output terminals.

TABLE 6-1. ADJUSTMENTS AFTER TRANSISTOR REPLACEMENTS

TRANSISTOR REPLACED	ADJUSTMENTS TO BE MADE	ADJUSTMENT PARAGRAPH
Q2, Q3, Q4 or Q5	Mark and spcae gain adjustments	6-2h
Q6, Q7, Q8, Q9, or Q10	Dc amplifier adjustments	6-2i

TABLE 6-2. FILTER CHARACTERISTICS

SYMBOL	NAME	INPUT TERMINATION (OHMS)	OUTPUT TERMINATION (OHMS)	REQUIRED FREQUENCY RESPONSE	ATTENUATION	INSERTION LOSS	TEST LEVEL
Z1 (figure 5-1)	Narrow-shift bandpass filter.	8000 +5% at 1000 cps.	8000 +5% at 1000 cps.	900 to 1100 cps	6 db bandwidth: 500 +50 cps. 40 db bandwidth: 1400 +100 cps.	3 db max. at 1000 cps.	10v rms. (no dc)
FL1 (figure 5-1)	Wideshift bandpass filter.	8000 +5% at 2000 cps.	8000 +5% at 2000 cps.	1500 to 2500 cps.	6 db bandwidth: 2100 +150 cps. 40 db bandwidth: 3100 +200 cps.	3 db max. at 2000 cps.	10v rms. (no dc)
FL4 (figure 5-1)	Lowpass keying filter. Section A: (terminals 1, 2, 3.)	20K +20% at 5 cps.	20K +20% at 5 cps.	0 to 45 cps.	2 db at 15 cps. 3.5 db at 45 cps. 18 db (min) at 140 cps. 65 db (min) from 1500 cps to 8000 cps.	- -	10v rms. (no dc)
	Lowpass keying filter. Section B: (terminals 4, 5, 6.)	20K +20% at 5 cps.	20K +20% at 5 cps.	0 to 175 cps.	2 db at 15 cps. 3.5 db at 175 cps. 18 db (min) at 560 cps 65 db (min) from 4000 cps to 8000 cps.	- -	10v rms. (no dc)

lower frequency from higher frequency.
Result must be 500 cps +50 cps.

Step 11. Increase audio oscillator frequency until vtm connected to TP- \star 1 indicates 0.05 volt, keeping audio oscillator output voltage constant. Record audio oscillator frequency. Decrease audio oscillator frequency until vtm connected to TP- \star 1 indicates 0.05 volt, keeping audio oscillator output voltage constant. Subtract lower frequency from higher frequency. Result must be 1400 cps +100 cps.

Step 12. Turn POWER switch to Off and disconnect vtm and audio oscillator from converter. Reconnect cable to AUDIO INPUT connector, J2, at rear of converter cabinet.

(7) DISCRIMINATOR TESTS. - Discriminator frequency response characteristics are given in the curves of figure 6-1. These are in terms of frequency versus output voltage. Resistance information is given in figure 6-2. Perform the following procedures to check the discriminator characteristics. Replace any discriminator not passing applicable tests.

(a) WIDE-SHIFT DISCRIMINATOR.

Step 1. Withdraw chassis to stops on drawer slides, and OPERATE INTERLOCK SWITCHES (figure 2-10) by pressing in on button at left side of switch block.

Step 2. Connect vtm, audio oscillator, and frequency meter to power source and turn power switches on. Allow at least 15 minutes warm-up for frequency meter.

Step 3. Set converter SHIFT switch to WIDE, and SPEED switch to SLOW. Turn POWER switch to On position. Allow five minute warm-up period.

Step 4. Remove cable attached to AUDIO INPUT connector, J2, at rear of converter cabinet.

Step 5. Connect audio oscillator output terminals to AUDIO INPUT connector, J2, or to terminals 1 and 3 of Z1 (figure 5-1).

Step 6. Set audio oscillator to 3 kc, using frequency meter.

Step 7. Set vtm range switch to 10 volts and connect to audio oscillator output terminals. Adjust audio oscillator to obtain vtm indication of 6.0 volts.

Step 8. Adjust multimeter to measure 15 volts dc.

Connect positive lead of multimeter to black test point, TP- \star 4 (figure 5-2). Connect negative lead of multimeter to converter chassis.

Step 9. Adjust converter LEVEL control to obtain multimeter indication of 15 volts.

Step 10. Adjust audio oscillator to 950 cps, using frequency meter, keeping output voltage at 6.0 volts. Reverse multimeter leads. Record multimeter indication.

Step 11. Increase audio oscillator frequency in 50 cps steps to 3150 cps. Record multimeter voltage indication at each frequency.

Step 12. Plot these points on a graph. Connect points with a smooth curve.

Step 13. Draw a straight line between 1650 and 2350 cps points. Frequency deviation from curve shall not be greater than 35 cps. Crossover point shall be between 1950 and 2050 cps. Peaks shall be 1150 +100 cps and 2850 +150 cps.

Step 14. Turn POWER switch to Off and disconnect vtm, multimeter, and audio oscillator from converter. Reconnect cable to AUDIO INPUT connector, J2, at rear of converter cabinet.

(b) NARROW-SHIFT DISCRIMINATOR.

Step 1. Withdraw chassis to stops on drawer slides, and operate interlock switches (figure 2-10) by pressing in on button at left side of switch block.

Step 2. Connect vtm, audio oscillator, and frequency meter to power source and turn power switches on. Allow at least 15 minutes warm-up for frequency meter.

Step 3. Set converter SHIFT switch to NARROW and turn POWER switch to On position. Allow five minute warm-up period.

Step 4. Remove cable connected to AUDIO INPUT connector, J2, at rear of converter cabinet.

Step 5. Connect audio oscillator output terminals to AUDIO INPUT connector, J2 or to terminals 1 and 3 of Z1 (figure 5-1).

Step 6. Set audio oscillator to 1200 cps, using frequency meter.

Step 7. Set vtm range switch to 10 volts and connect to audio oscillator output terminals. Adjust

- audio oscillator to obtain vtm indication of 6.0 volts.
- Step 8. Adjust multimeter to measure 15 volts dc. Connect positive lead of multimeter to black test point, TP- 4 (figure 5-2). Connect negative lead of multimeter to converter chassis.
- Step 9. Adjust converter LEVEL control to obtain multimeter indication of 15 volts.
- Step 10. Adjust audio oscillator to 500 cps, keeping output voltage at 6.0 volts. Reverse multimeter leads. Record multimeter indication.
- Step 11. Increase audio oscillator frequency in 100 cps steps to 700 cps and in 20 cps steps from 700 cps to 1500 cps. Record multimeter voltage indication at each frequency.
- Step 12. Plot these points on a graph. Connect points with a smooth curve.
- Step 13. Draw a straight line between 900 and 1100 cps points. Frequency deviation from curve shall not be greater than 15 cps. Crossover point shall be between 980 and 1020 cps. Peaks shall be 800 +30 cps and 1200 +40 cps.
- Step 14. Turn POWER switch to Off and disconnect vtm, multimeter, and audio oscillator from converter. Reconnect cable to AUDIO INPUT connector, J2, at rear of converter cabinet.
- (8) LOW-PASS KEYING FILTER TESTS. -
Table 6-2 lists characteristics of low-pass keying filter. Resistance information is given in figure 6-2. Perform the following procedures to check characteristics of low-pass keying filter FL4. Replace filter if it fails these tests.
- Step 1. Withdraw chassis to stops on drawer slides, and operate interlock switches (figure 2-10) by pressing in on button at left side of switch block.
- Step 2. Connect vtm's, audio oscillator, and frequency meter to power source and turn power switches on. Allow at least 15 minutes warm-up for frequency meter.
- Step 3. Set converter SPEED switch to SLOW, and turn POWER switch to On position. Allow five minute warm-up period.
- Step 4. Connect a 20k +1% resistor to 'hot' terminal of audio oscillator. Connect other end of resistor to terminal 1 of FL4 (figure 5-1). Connect ground terminal of audio oscillator to converter chassis.
- Step 5. Adjust audio oscillator frequency to 15 cps, using frequency meter.
- Step 6. Connect a 20k +1% resistor across vtm terminals.
- Step 7. Set vtm range switch to 10 volts. Connect vtm between terminal 3 of FL4 and converter chassis using coaxial cable.
- Step 8. Adjust audio oscillator for vtm indication of 5.0 volts.
- Step 9. Set range switch of second vtm to 10 volts and connect to audio oscillator output terminals (on oscillator side of 20K resistor). Record vtm indication.
- Step 10. Increase audio oscillator frequency to 45 cps, keeping output voltage constant. Indication of vtm connected to terminal 3 of FL4 must be 3.15 to 4.0 volts.
- Step 11. Increase audio oscillator frequency to 140 cps, keeping output voltage constant. Indication of vtm connected to terminal 3 of FL4 must not be greater than 0.63 volt.
- Step 12. Increase audio oscillator frequency to 560 cps, keeping output voltage constant. Indication of vtm connected to terminal 3 of FL4 must not be greater than 0.016 volt.
- Step 13. Increase audio oscillator frequency to 8 kc, keeping output voltage constant. Indication of vtm connected to terminal 3 of FL4 must not be greater than 0.0027 volt at any frequency from 1500 cps to 8 kc.
- Step 14. Set converter SPEED switch to FAST.
- Step 15. Adjust audio oscillator frequency to 60 cps, using frequency meter.
- Step 16. Move audio oscillator lead from terminal 1 of FL4 to terminal 4 of FL4.
- Step 17. Move vtm lead from terminal 3 of FL4 to terminal 6 of FL4.
- Step 18. Adjust audio oscillator output for 5.0 volt

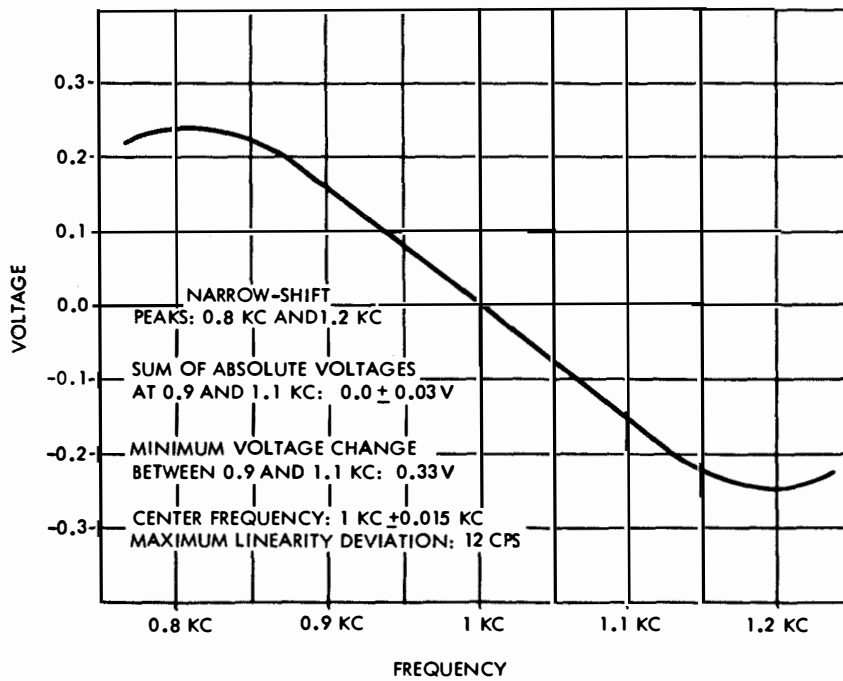
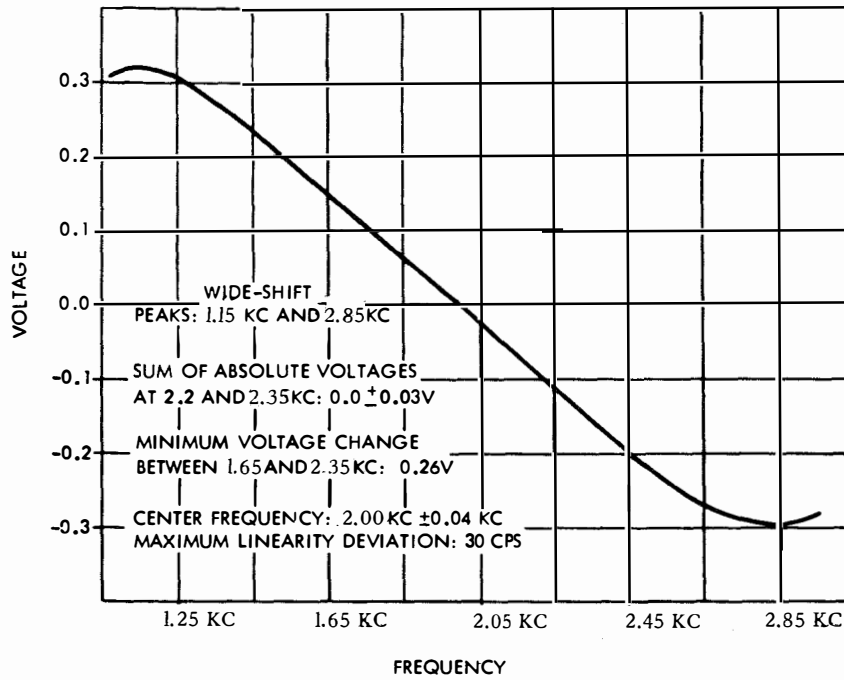

Figure 6-1. Discriminator Frequency Response Curves

	TERMINALS	RESISTANCE	SCHEMATIC	ACTUAL
FL1	1 to 2 1 to 3 2 to 3	∞ ∞ ∞		
FL2	1 to 4 2 to 3 3 to 4	42 Ω 186 Ω 223 Ω		
FL3	1 to 3 2 to 3 3 to 4	42 Ω 160 Ω 103 Ω		
FL4	1 to 2 1 to 3 2 to 3 4 to 5 4 to 6 5 to 6	∞ 3060 Ω ∞ ∞ 3125 Ω ∞		
T1, T2	1 to 2 3 to 4 3 to 5 4 to 5	35 Ω 590 Ω 1260 Ω 670 Ω		
Z1	1 to 2 1 to 3 4 to 5 6 to 7 7 to 8	10.3 Ω 22.2 Ω 464 Ω 55 Ω 55 Ω		

ALL RESISTANCE MEASUREMENTS $\pm 20\%$

Figure 6-2. Filter and Transformer Resistance Data

indication on vtvm connected to terminal 6 of FL4.

not be greater than 0.63 volt.

Step 19. Record audio oscillator output voltage (on oscillator side of 20k resistor).

Step 22. Increase audio oscillator frequency to 2240 cps, keeping output voltage constant. Indication of vtvm connected to terminal 6 of FL4 must not be greater than 0.016 volt.

Step 20. Increase audio oscillator frequency to 175 cps, keeping output voltage constant. Indication of vtvm connected to terminal 6 of FL4 must be 3.15 to 4.0 volts.

Step 23. Increase audio oscillator frequency to 8 kc, keeping output voltage constant. Indication of vtvm connected to terminal 6 of FL4 must not be greater than 0.0027 volt at any frequency from 4 kc to 8 kc.

Step 21. Increase audio oscillator frequency to 560 cps, keeping output voltage constant. Indication of vtvm connected to terminal 6 of FL4 must

Step 24. Turn POWER switch to Off and disconnect audio oscillator and vtvm from converter.

WIRE CHART						WIRE CHART (CONT)					
WIRE NO.	STA	FROM	TERM.	TO	TERM.	WIRE NO.	STA	FROM	TERM.	TO	TERM.
1	1	S4	7	TB1	27	WHT-RED					
2	1	S4	10	TB2	44	WHT-YEL-RED					
3	1	S4	12	J1	6	WHT-ORN-GRN(SHLD)					
4	1	S4	5	TB2	33	WHT-ORN-VIO					
5	1	S4	6	J1	21	WHT-BLK-BRN(SHLD)					
6	1	S4	7	J1	9	WHT					
7	2	S1B	10	TB2	2	WHT-ORN-BRN(SHLD)					
8	2	S1B	11	FL2	4	WHT-BLK-VIO(SHLD)					
9	2	S1B	12	FL3	4	WHT-BRN(SHLD)					
10	2	S1B	1	TB2	57	BLK					
11	2	S1B	2	FL2	1	WHT-RED-GRN(SHLD)					
12	2	S1B	3	FL3	1	WHT-RED-BLU(SHLD)					
13	2	S1B	4	TB2	55	BLK					
14	2	S1B	5	FL2	2	WHT-ORN-BLK(SHLD)					
15	2	S1B	6	FL3	2	WHT-BLK(SHLD)					
16	3	S1A	1	Z1	4	WHT-ORN-BLU(SHLD)					
17	3	S1A	2	Z1	6	WHT-BRN-VIO					
18	3	S1A	3	FL1	1	WHT-BLK-YEL					
19	3	S1A	4	TB2	31	WHT-ORN-GRN					
20	3	S1A	5	Z1	6	WHT-VIO-GRN					
21	3	S1A	6	FL1	3	WHT-BLK-GRN					
22	4	R4	1	TB2	36	WHT-BLU					
23	4	R4	2	TB2	53	WHT-ORN					
24	4	R4	3	TB2	33	WHT-YEL					
25	5	Z1	1	J1	1	WHT-ORN-RED(SHLD)					
26	5	Z1	2	J1	3	WHT-BRN-GRN(SHLD)					
27	5	Z1	5	TB2	51	BLK					
28	5	Z1	3	J1	2	WHT-BRN-RED(SHLD)					
29	5	Z1	7	TB2	44	BLK					
30	6	FL1	2	TB2	43	BLK					
31	7	FL3	3	TB2	35	BLK					
32	8	FL3	3	TB2	32	BLK					
33	9	T1	1	TB2	11	WHT					
34	9	T1	2	TB2	6	WHT-GY-BLU					
35	9	T1	3	TB2	30	WHT-ORN-GY					
36	9	T1	5	TB2	28	WHT-VIO-VIO					
37	9	T1	4	TB2	29	WHT-RED-RED					
38	10	T2	2	TB2	8	BLU					
39	10	T2	1	TB2	11	WHT					
40	10	T2	3	TB2	20	WHT-GRN-BLU					
41	10	T2	5	TB2	18	WHT-BLK-BLU					
42	10	T2	4	TB2	19	WHT-BRN-GY					
43	11	Q4	8	TB2	5	WHT-ORN-YEL					
44	11	Q4	10	TB2	6	WHT-ORN-YEL					
45	11	Q4	8	TB2	7	WHT-BRN-YEL					
46	11	Q4	8	TB2	9	GRN					
47	12	Q5	12	TB2	4	BLU					
48	12	Q5	8	TB2	10	WHT-GY-YEL					
49	13	J1	8	TB2	50	WHT-BLU-YEL(SHLD)					
50	13	J1	9	TB2	51	BLK					
51	13	J1	10	TB2	52	WHT-GY					
52	13	J1	12	TB2	26	WHT-ORN-YEL					
53	13	J1	14	TB2	1	BLK					
54	14	R17	1	TB2	15	WHT-YEL					
55	14	R17	2	TB2	16	WHT					
56	14	R17	3	TB2	1	BLK					
57	14	R96	1	TB2	22	YEL					
58	14	R96	2	TB2	23	WHT					
59	14	R96	3	TB2	24	BLK					
60	15	R77	1	TB2	46	WHT					
61	15	R77	2	TB2	48	YEL					
62	15	R77	3	TB2	47	WHT-YEL					
63	15	R80	1	TB2	59	WHT-ORN-VIO					
64	15	R80	2	TB2	60	YEL					
65	15	R80	3	TB2	61	WHT					
66	16	TB2	37	TB2	49	RED					
67	16	TB2	12	TB2	38	VIO					
68	16	TB2	37	TB1	42	RED					
69	16	TB2	4	TB2	34	WHT-VIO					
70	16	TB2	27	J1	2	WHT-ORN(SHLD)					
71	16	TB2	21	J1	32	BLK					
72	16	TB2	12	TB1	50	VIO					
73	16	TB2	4	TB1	41	WHT-VIO					
74	16	TB2	16	TB2	17	WHT					
75	16	TB2	40	TB2	41	WHT					
76	16	TB2	42	TB2	45	WHT					
77	17	P1	1	J2	A	WHT-ORN-RED(SHLD)					
78	17	P1	1	J2	A	WHT-ORN-RED(SHLD)					
79	17	P1	3	J2	B	WHT-ORN-RED(SHLD)					
80	17	P1	3	J2	B	WHT-ORN-RED(SHLD)					
81	17	P1	5	J2	C	WHT-ORN-RED(SHLD)					
82	17	P1	5	J2	C	WHT-ORN-RED(SHLD)					
83	17	P1	7	J2	D	WHT-ORN-RED(SHLD)					
84	17	P1	7	J2	D	WHT-ORN-RED(SHLD)					
85	17	P1	9	J2	E	WHT-ORN-RED(SHLD)					
86	17	P1	9	J2	E	WHT-ORN-RED(SHLD)					
87	17	P1	10	J2	F	WHT-ORN-RED(SHLD)					
88	17	P1	10	J2	F	WHT-ORN-RED(SHLD)					
89	17	P1	12	J2	G	WHT-ORN-RED(SHLD)					
90	17	P1	12	J2	G	WHT-ORN-RED(SHLD)					
91	17	P1	14	J2	H	WHT-ORN-RED(SHLD)					
92	17	P1	14	J2	H	WHT-ORN-RED(SHLD)					
93	17	P1	18	J2	I	WHT-ORN-RED(SHLD)					
94	17	P1	18	J2	I	WHT-ORN-RED(SHLD)					
95	17	P1	18	J2	J	WHT-ORN-RED(SHLD)					
96	17	P1	18	J2	J	WHT-ORN-RED(SHLD)					
97	17	P1	18	J2	K	WHT-ORN-RED(SHLD)					
98	17	P1	18	J2	K	WHT-ORN-RED(SHLD)					
99	17	P1	18	J2	L	WHT-ORN-RED(SHLD)					
100	17	P1	18	J2	L	WHT-ORN-RED(SHLD)					
101	17	P1	18	J2	M	WHT-ORN-RED(SHLD)					
102	17	P1	18	J2	M	WHT-ORN-RED(SHLD)					
103	17	P1	18	J2	N	WHT-ORN-RED(SHLD)					
104	17	P1	18	J2	N	WHT-ORN-RED(SHLD)					
105	17	P1	18	J2	O	WHT-ORN-RED(SHLD)					
106	17	P1	18	J2	O	WHT-ORN-RED(SHLD)					
107	17	P1	18	J2	P	WHT-ORN-RED(SHLD)					
108	17	P1	18	J2	P	WHT-ORN-RED(SHLD)					
109	17	P1	18	J2	Q	WHT-ORN-RED(SHLD)					
110	17	P1	18	J2	Q	WHT-ORN-RED(SHLD)					
111	17	P1	18	J2	R	WHT-ORN-RED(SHLD)					
112	17	P1	18	J2	R	WHT-ORN-RED(SHLD)					
113	17	P1	18	J2	S	WHT-ORN-RED(SHLD)					
114	17	P1	18	J2	S	WHT-ORN-RED(SHLD)					
115	17	P1	18	J2	T	WHT-ORN-RED(SHLD)					
116	17	P1	18	J2	T	WHT-ORN-RED(SHLD)					
117	17	P1	18	J2	U	WHT-ORN-RED(SHLD)					
118	17	P1	18	J2	U	WHT-ORN-RED(SHLD)					
119	17	P1	18	J2	V	WHT-ORN-RED(SHLD)					
120	17	P1	18	J2	V	WHT-ORN-RED(SHLD)					
121	17	P1	18	J2	W	WHT-ORN-RED(SHLD)					
122	17	P1	18	J2	W	WHT-ORN-RED(SHLD)					
123	17	P1	18	J2	X	WHT-ORN-RED(SHLD)					
124	17	P1	18	J2	X	WHT-ORN-RED(SHLD)					
125	17	P1	18	J2	Y	WHT-ORN-RED(SHLD)					
126	17	P1	18	J2	Y	WHT-ORN-RED(SHLD)					
127	17	P1	18	J2	Z	WHT-ORN-RED(SHLD)					
128	17	P1	18	J2	Z	WHT-ORN-RED(SHLD)					
129	17	P1	18	J2	1	WHT-ORN-RED(SHLD)					
130	17	P1	18	J2	1	WHT-ORN-RED(SHLD)					
131	17	P1	18	J2	2	WHT-ORN-RED(SHLD)					
132	17	P1	18	J2	2	WHT-ORN-RED(SHLD)					
133	17	P1	18	J2	3	WHT-ORN-RED(SHLD)					
134	17	P1	18	J2	3	WHT-ORN-RED(SHLD)					
135	17	P1	18	J2	4	WHT-ORN-RED(SHLD)					
136	17	P1	18	J2	4	WHT-ORN-RED(SHLD)					
137	17	P1	18	J2	5	WHT-ORN-RED(SHLD)					
138	17	P1	18	J2	5	WHT-ORN-RED(SHLD)					
139	17	P1	18	J2	6	WHT-ORN-RED(SHLD)					
140	17	P1	18	J2	6	WHT-ORN-RED(SHLD)					
141	17	P1	18	J2	7	WHT-ORN-RED(SHLD)					
142	17	P1	18	J2	7	WHT-ORN-RED(SHLD)					
143	17	P1	18	J2	8	WHT-ORN-RED(SHLD)					
144	17	P1	18	J2	8	WHT-ORN-RED(SHLD)					
145	17	P1	18	J2	9	WHT-ORN-RED(SHLD)					
146	17	P1	18	J2	9	WHT-ORN-RED(SHLD)					
147	17	P1	18	J2	10	WHT-ORN-RED(SHLD)					
148	17	P1	18	J2	10	WHT-ORN-RED(SHLD)					
149	17	P1	18	J2	11	WHT-ORN-RED(SHLD)					
150	17	P1	18	J2	11	WHT-ORN-RED(SHLD)					
151	17	P1	18	J2	12	WHT-ORN-RED(SHLD)					
152	17	P1	18	J2	12	WHT-ORN-RED(SHLD)					
153	17	P1	18	J2	13	WHT-ORN-RED(SHLD)					
154	17	P1	18	J2	13	WHT-ORN-RED(SHLD)					
155	17	P1	18	J2	14	WHT-ORN-RED(SHLD)					
156	17	P1	18	J2	14	WHT-ORN-RED(SHLD)					
157	17	P1	18	J2	15	WHT-ORN-RED(SHLD)					
158	17	P1	18	J2	15	WHT-ORN-RED(SHLD)					
159	17	P1	18	J2	16	WHT-ORN-RED(SHLD)					
160	17	P1	18	J2	16	WHT-ORN-RED(SHLD)					
161	17	P1	18	J2	17	WHT-ORN-RED(SHLD)					
162	17	P1	18	J2	17	WHT-ORN-RED(SHLD)					
163	17	P1	18	J2	18	WHT-ORN-RED(SHLD)					
164	17	P1	18	J2	18	WHT-ORN-RED(SHLD)					
165	17	P1	18	J2	19	WHT-ORN-RED(SHLD)					
166	17	P1	18	J2	19	WHT-ORN-RED(SHLD)					

NOTES:
THIS END OF SHIELD NOT TERMINATED. (SHIELD ENDS IN CABLE, NEAR BREAKOUT.)

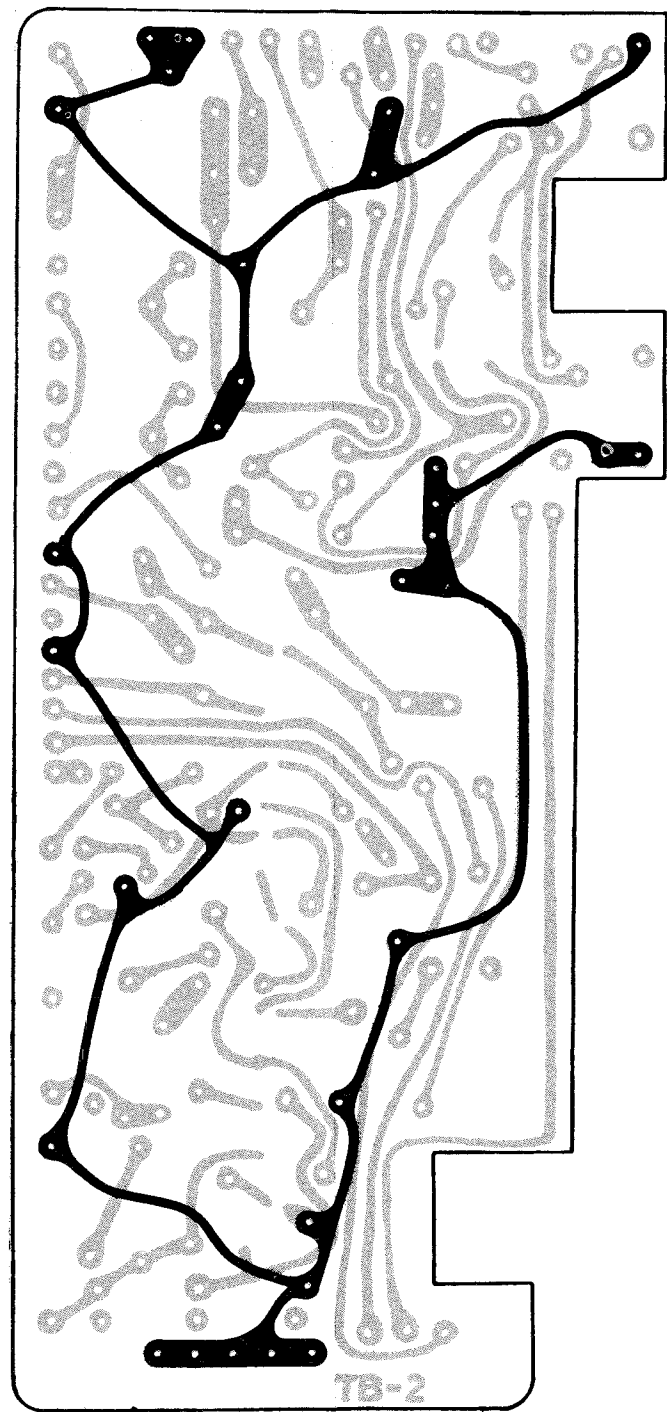

DARK LINES REPRESENT LEADS ON REAR OF TERMINAL BOARD.
LIGHT LINES REPRESENT LEADS ON FRONT OF TERMINAL BOARD.

ORIGINAL

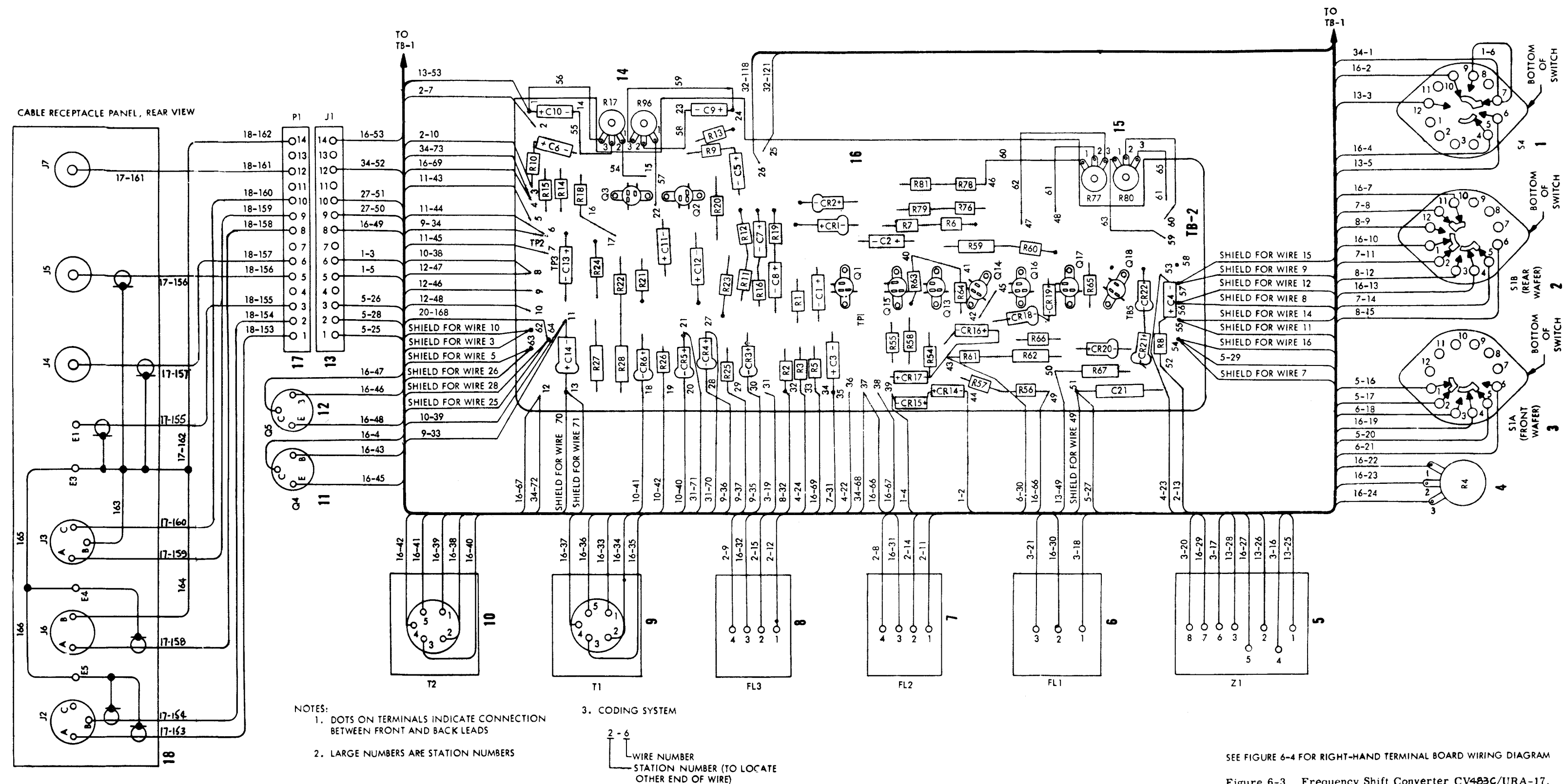

NOTES:
1. DOTS ON TERMINALS INDICATE CONNECTION BETWEEN FRONT AND BACK LEADS
2. LARGE NUMBERS ARE STATION NUMBERS
3. CODING SYSTEM
WIRE NUMBER STATION NUMBER (TO LOCATE OTHER END OF WIRE)

SEE FIGURE 6-4 FOR RIGHT-HAND TERMINAL BOARD WIRING DIAGRAM

Figure 6-3 Frequency Shift Converter CV483C/URA-17, Left-Hand Terminal Board, Wiring Diagram 6-11.6-12

WIRE CHART							
WIRE NO	FROM STA	FROM DESIGNATION	TERM	TO STA	TO DESIGNATION	TERM	COLOR
77	19	C31	A	34	TB1	18	WHT-ORN-VIO
78	19	C31	C	34	TB1	49	BLK
79	19	C31	A	19	C31	8	WHT
80	20	E2	--	21	C27	C	BLK
81	20	E2	--	24	T4	8	WHT-BLK
83	21	C27	B	34	TB1	16	WHT-ORN-BLU
84	21	C27	A	34	TB1	70	WHT-ORN-RED
87	23	T3	1	24	T4	1	WHT-GY-GY
88	23	T3	3	24	T4	3	WHT-RED-GY
89	23	T3	5	34	TB1	45	WHT-ORN-BLK
90	23	T3	6	34	TB1	60	WHT-BLK-VIO
91	24	T4	1	28	S6	2	WHT-GY-GY
92	24	T4	6	34	TB1	44	WHT-GRN-GRN
93	24	T4	7	34	TB1	29	WHT-BRN-GRN
94	24	T4	3	28	S6	1	WHT-RED-GY
95	24	T4	9	32	XV1	1	WHT-BRN
96	24	T4	5	34	T3	5	WHT-VIO-YEL
97	24	T4	10	32	XV1	12	BRN
99	25	CR34	8	34	TB1	R85	WHT-GRN
101	25	FL4	1	30	S3	12	WHT-ORN-BLU(SHLD)
102	25	FL4	2	34	TB1	4	BLK
103	25	FL4	3	30	S3	6	WHT-ORN-ORN(SHLD)
104	25	FL4	4	30	S3	1	WHT-RED-GRN(SHLD)
105	25	FL4	5	34	TB1	4	BLK
106	25	FL4	6	30	S3	2	BLK
107	27	S6A	NC	29	XF2	END	WHT-ORN-GY
108	27	S6B	NC	29	XF1	END	WHT-GY-BLU
109	28	S6	4	29	XF2	1	WHT-ORN-GY
110	28	S6	2	29	XDS1	2	WHT-GY-GY
111	28	S6	1	29	XDS1	1	WHT-RED-GY
112	28	S6	3	29	XF1	1	WHT-ORN-GY
113	30	S3	11	31	S2	4	WHT-RED-RED
114	30	S3	5	34	TB1	4	WHT-RED-BLK
115	31	S2	1	34	TB1	4	BLK
116	31	S2	2	31	S2	5	WHT
117	31	S2	3	31	S2	6	WHT
118	32	XV1	10	16	TB2	26	WHT-ORN-BRN
119	32	XV1	9	34	TB1	28	WHT-BRN-BLU
120	32	XV1	8	34	TB1	38	WHT-BLK
121	32	XV1	7	16	TB2	25	WHT-ORN
122	32	XV1	6	34	TB1	29	WHT-ORN-GRN
123	32	XV1	4	34	TB1	51	WHT-BLK-BRN
124	32	XV1	3	34	TB1	18	WHT-ORN-VIO
125	32	XV1	2	34	TB1	52	WHT-RED-GRN
126	32	XV1	1	34	TB1	3	WHT
127	33	R31	1	34	TB1	5	WHT-YEL
128	33	R31	2	34	TB1	6	WHT
129	33	R31	3	34	TB1	8	YEL
130	33	R93	1	34	TB1	17	BRN
131	33	R93	2	34	TB1	52	WHT-RED-GRN
132	33	R93	3	34	TB1	16	WHT
133	33	R92	1	34	TB1	17	BRN
134	33	R92	2	34	TB1	31	WHT-BLK-BRN
135	33	R92	3	34	TB1	19	WHT
136	34	R89	1	34	TB1	37	WHT
137	34	R89	2	34	TB1	35	GRN
138	34	R89	3	34	TB1	26	WHT-GRN
139	34	R72	1	34	TB1	40	WHT
140	34	R72	2	34	TB1	43	GRN
141	34	R72	3	34	TB1	39	WHT-GRN
142	34	C26	50	34	TB1	CR22	VIO
143	34	CR27	46	34	TB1	25	VIO
144	34	TB1	25	34	TB1	32	VIO
145	34	TB1	42	34	TB1	23	RED
146	34	TB1	23	34	TB1	21	VIO
147	34	TB1	12	34	TB1	7	RED
148	34	TB1	11	34	TB1	9	RED
149	34	TB1	1	34	TB1	9	RED
150	34	R39	1	34	TB1	13	WHT
151	34	R39	2	34	TB1	14	GRN
152	34	R39	3	34	TB1	15	WHT-GRN
167	34	TB1	49	20	E2		BLK
168	20	E2		16	TB2	64	BLK

NOTES:
* THIS END OF SHIELD NOT TERMINATED. (SHIELD ENDS IN CABLE, NEAR BREAKOUT.)

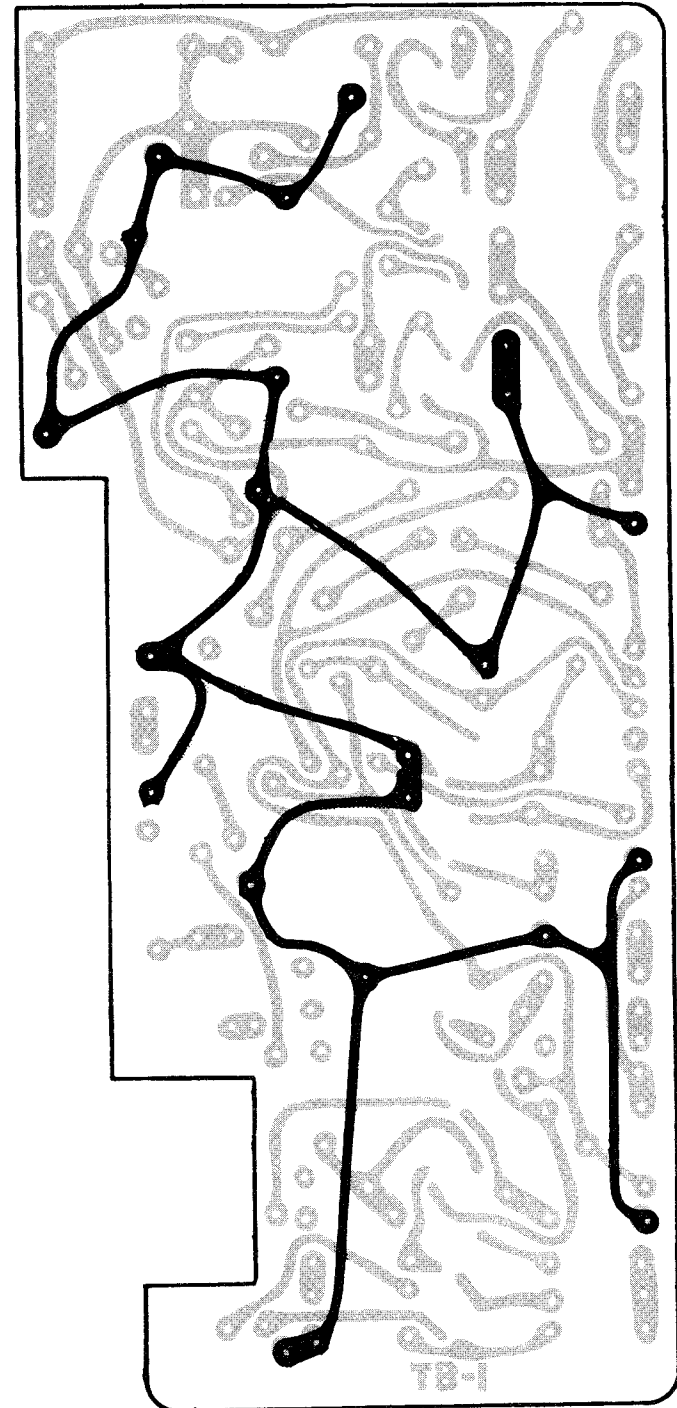

DARK LINES REPRESENT LEADS ON REAR OF TERMINAL BOARD.
LIGHT LINES REPRESENT LEADS ON FRONT OF TERMINAL BOARD.

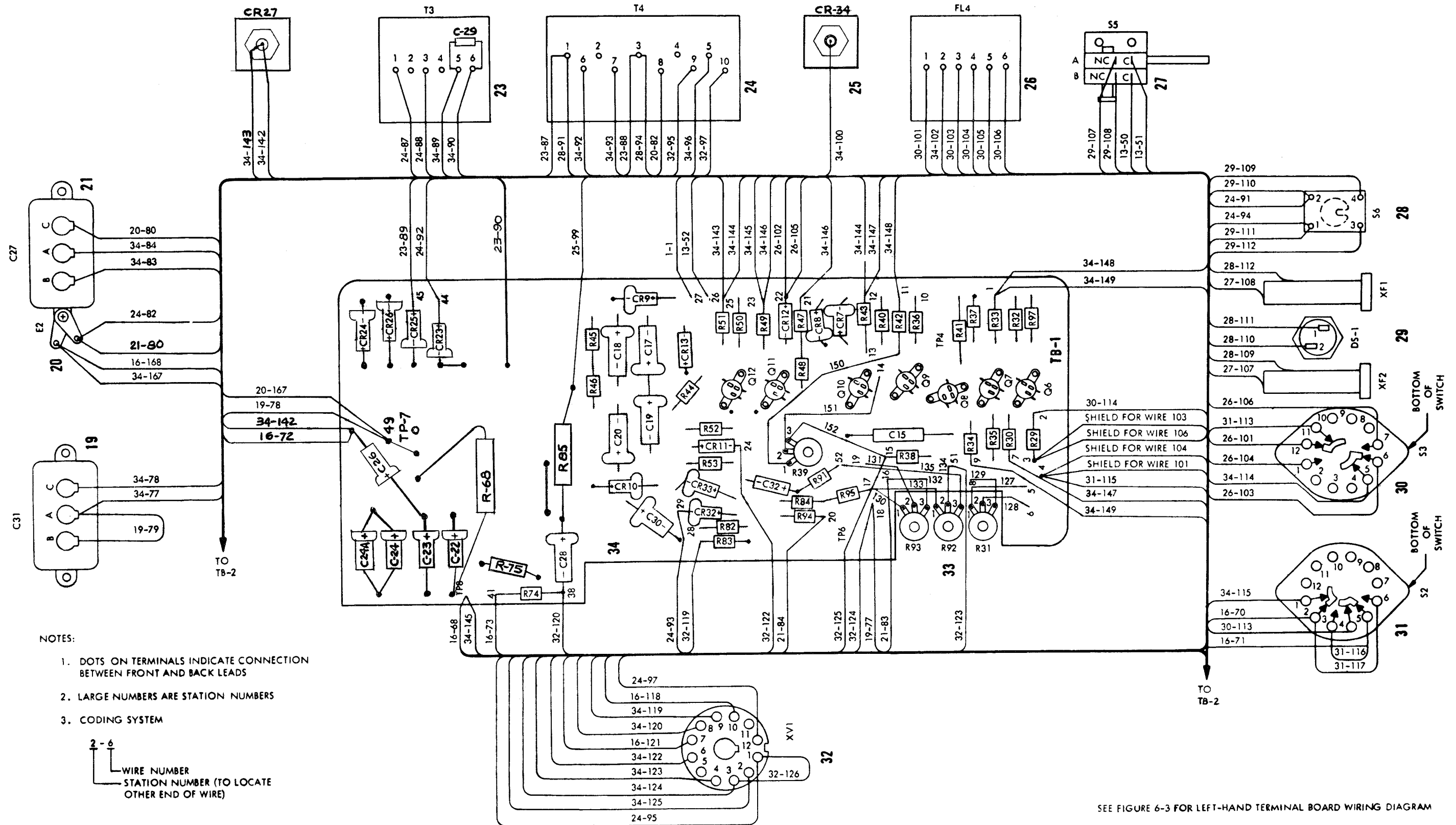

SEE FIGURE 6-3 FOR LEFT-HAND TERMINAL BOARD WIRING DIAGRAM
Figure 6-4. Frequency Shift Converter CV-483C/URA-17. Right-Hand Terminal Board, Wiring Diagram

TABLE OF ROAD MAP COORDINATES FOR FIGURE 6-5							
REFERENCE DESIGNATION	COORDINATES	REFERENCE DESIGNATION	COORDINATES	REFERENCE DESIGNATION	COORDINATES	REFERENCE DESIGNATION	COORDINATES
C1	3A	CR19	13B	R1	3A	R54	12A
C2	4A	CR20	14B	R2	3A	R55	12A
C3	4B	CR21	14B	R3	3B	R56	12A
C4	4B	CR22	14B	R4	3B	R57	12B
C5	5A	CR23	3C	R5	3B	R58	12A
C6	5A	CR24	3C	R6	4A	R59	12B
C7	6A	CR25	3C	R7	4A	R60	12B
C8	6A	CR26	3C	R8	4B	R61	12B
C9	5B	CR27	4C	R9	5A	R62	13B
C10	5B	CR32	3D	R10	5A	R63	13B
C11	6B	CR33	3D	R11	5A	R64	13B
C12	6B	CR34	4B	R12	5B	R65	13B
C13	6B			R13	5B	R66	13A
C14	6B	DS1	2D	R14	5B	R67	14B
C15	10B			R15	5B	R68	3C
C16	N/U	E1	1B	R16	5A	R74	5C
C17	10A	F1	1D	R17	5B	R75	5C
C18	11A	F2	1D	R18	5B	R76	5C
C19	10A			R19	6B	R77	5C
C20	10B	FL1	3B	R20	6B	R78	5C
C21	13B	FL2	4B	R21	6B	R79	5C
C22	3C	FL3	4B	R22	6B	R80	5C
C23	3C	FL4	8A	R23	6B	R81	5C
C24	3C			R24	6B	R82	2D
C24A	3C			R25	7A	R83	2D
C26	4C	J1	1B, 14A	R26	7B	R84	3D
C27A	2D	J2	1B	R27	7B	R85	3C
C27B	5D	J3	1B	R28	7B	R91	5C
C28	3D	J4	14A	R29	8B	R92	5C
C29	2C	J5	14A	R30	8B	R93	5D
C30	4D	J6	14A	R31	8B	R94	5D
C31A	5D	J7	14B	R32	8A	R95	6D
C31B	6B			R33	9A	R96	5A
C32	11C	P1	1B, 14A	R34	9A	R97	8A
CR1	3A	Q1	3A	R35	9A	S1A	3A
CR2	3A	Q2	5A	R36	9A	S1B	4B
CR3	7A	Q3	5B	R37	10A	S2	7A
CR4	7A	Q4	6A	R38	10A	S3	8B
CR5	7B	Q5	6B	R39	10B	S4	11A
CR6	7B	Q6	8B	R40	10B	S5A	1C
CR7	10B	Q7	9B	R41	10A	S5B	1C
CR8	10B	Q8	9B	R42	10B	S6	2D
CR9	11A	Q9	9B	R43	10A	T1	6A
CR10	11B	Q10	10B	R44	11A	T2	6B
CR11	10C	Q11	11C	R45	11B	T3	2C
CR12	11C	Q12	11C	R46	11C	T4	2C
CR13	11C	Q13	12B	R47	11C	T5	6C
CR14	11A	Q14	12B	R48	11C	V1	6C
CR15	11B	Q15	12B	R49	11C	Z1	2B
CR16	11A	Q16	12B	R50	11C		
CR17	11B	Q17	13B	R51	11C		
CR18	13A	Q18	13B	R52	11C		
				R53	11B		

NOTE: N/U = NOT USED

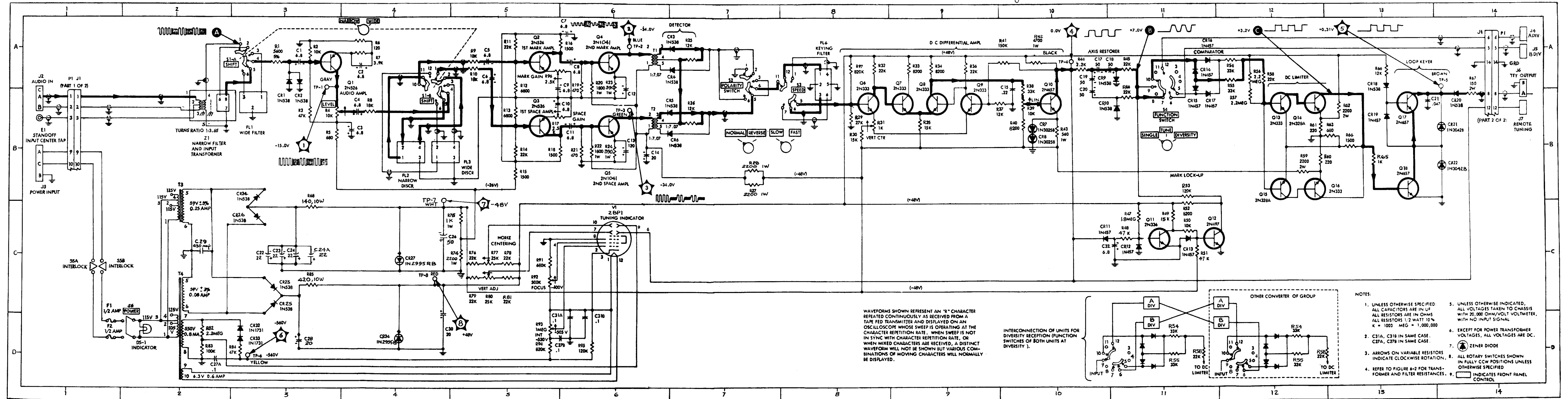

Figure 6-5. Frequency Shift Converter CV485C/URA-17, Overall Schematic Diagram

SECTION 7
PARTS LIST

7-1. INTRODUCTION.

Reference designations have been assigned to identify all maintenance parts of Comparator-Converter Group AN/URA-17C, hereinafter referred to as the AN/URA-17C. They are used for marking the equipment (adjacent to the part they identify) and are included on drawings, diagrams, and the parts list. The letters of a reference designation indicate the kind of part (generic group), such as resistor, capacitor, transistor, etc. The number differentiates between parts of the same generic group. Sockets are associated with a particular plug-in device, such as a transistor or fuse, are identified by a reference designation which includes the reference designation of the plug-in device. For example, the socket for fuse F1 is designated XF1.

Stock Number Identification Tables (SNIT) or Allowance Parts List (APS) issued by the Electronics Supply Office include Federal Stock Numbers and Source Maintenance and Recoverability Codes. Therefore, reference shall be made to the appropriate SNIT or APL for this information.

7-2. MAINTENANCE PARTS LIST.

Table 7-1 lists all maintenance parts used in the AN/URA-17C. Column 1 lists the reference designations of the various parts in alphabetical and numerical order. Column 2 refers to explanatory notes, if any, that appear in paragraph 7-4. Column 3 gives the name and describes the various parts. Complete information is given for all key parts (parts differing from any part previously listed in this table). The name and description are omitted for other parts. However, reference is made to the key part for the data. Column 4 indicates how the part is used and gives its functional location in the equipment. The figure listed shows the physical location of the part.

7-3. LIST OF MANUFACTURERS.

Table 7-2 lists manufacturers of parts used in the AN/URA-17C.

7-4. NOTES.

Not applicable.

TABLE 7-1. COMPARATOR-CONVERTER GROUP AN/URA-17C,
MAINTENANCE PARTS LIST

REF. DESIG.	NOTES	NAME AND DESCRIPTION	LOCATING FUNCTION
1-199		CONVERTER, FREQUENCY SHIFT: CV-483C/URA-17 ORION part/dwg No. D-030602-1	Two such units constitute one AN/URA-17C.
CR1		SEMICONDUCTOR DEVICE, DIODE: Germanium, 19500, type JANIN538 per MIL-S-19500	Limiter at input to Q1 (Figure 6-3)
CR2		Same as CR1	Limiter at input to Q1 (Figure 6-3)
CR3		Same as CR1	High frequency (mark) detector (Figure 6-3)
CR4		Same as CR1	High frequency (mark) detector (Figure 6-3)
CR5		Same as CR1	Low frequency (space) detector (Figure 6-3)
CR6		Same as CR1	Low frequency (space) detector (Figure 6-3)

TABLE 7-. COMPARATOR-CONVERTER GROUP AN/URA-17C,
MAINTENANCE PARTS LIST (Continued)

REF DESIG.		NAME AND DESCRIPTION	LOCATING FUNCTION
CR7		SEMICONDUCTOR DEVICE, DIODE: Zener, per MIL-S-19500/II5, type JAN1N3025B	Zener regulator, Q10 emitter (Figure 6-4)
CR8		Same as CR7	Zener regulator, Q10 emitter (Figure 6-4)
CR9		Same as CR1	Positive signal clamp at axis restorer (Figure 6-4)
CR10		Same as CR1	Negative signal clamp at axis restorer (Figure 6-4)
CR11		SEMICONDUCTOR DEVICE, DIODE: Silicon, per MIL-S-19500, type JAN1N457	Key pulse rectifier, mark lock-up input (Figure 6-4)
CR12		Same as CR11	Bias discharge, Q11 base (Figure 6-4)
CR13		Same as CR11	Q12 base bias (Figure 6-4)
CR14		Same as CR11	P/O diversity comparator network work (Figure 6-3)
CR15		Same as CR11	P/O diversity comparator network (Figure 6-3)
CR16		Same as CR11	P/O diversity comparator network (Figure 6-3)
CR17		Same as CR11	P/O diversity comparator network (Figure 6-3)
CR18		Same as CR1	Isolates +48 vdc and keyer +120 vdc (Figure 6-3)
CR19		Same as CR11	Protects Q17 emitter (Figure 6-3)
CR20		Same as CR1	Protects against reversal of +120 vdc keyer supply (Figure 6-3)
CR21		SEMICONDUCTOR DEVICE, DIODE: Zener, per MIL-S-19500/II5, type JAN1N3042B	Protects against inductive kickback from keyer relay (Figure 6-3)
CR22		Same as CR21	Protects against inductive kickback from keyer relay (Figure 6-3)
CR23		Same as CR1	-48 vdc supply rectifier (Figure 6-4)
CR24		Same as CR1	-48 vdc supply rectifier (Figure 6-4)
CR25		Same as CR1	-48 vdc supply rectifier (Figure 6-4)
CR26		Same as CR1	-48 vdc supply rectifier (Figure 6-4)

TABLE 7-1. COMPARATOR-CONVERTER GROUP AN/URA-17C,
MAINTENANCE PARTS LIST (Continued)

REF DESIG.	NAME AND DESCRIPTION	LOCATING FUNCTION
CR27	SEMICONDUCTOR DEVICE, DIODE: per MIL-S-19500/115, type JAN1N2995B	Bias stabilizer, Q19 emitter (Figure 6-4)
CR28	Not Used	
CR29	Not Used	
CR30	Not Used	
CR31	Not Used	
CR32	SEMICONDUCTOR DEVICE, DIODE: Silicon per MIL-S-19500/142, type JAN1N1731	-560 vdc supply rectifier (Figure 6-4)
CR33	Not Used	
CR34	SEMICONDUCTOR DEVICE, DIODE: Per MIL-S-19500/115, type JAN1N2995BR	+48 volt regulator
C1	CAPACITOR, FIXED, ELECTROLYTIC: Tantalytic, 6.8 uf, 35 vdc working, part no. CS13AF6R8M	Coupling, S1-A to Q1 base (Figure 6-3)
C2	Same as C1	Bypass, Q1 emitter (Figure 6-3)
C3	Same as C1	Decoupling, Q1 collector (Figure 6-3)
C4	Same as C1	Coupling, Q1 collector to S1-B (Figure 6-3)
C5	Same as C1	Coupling, S1-B to Q2 base (Figure 6-3)
C6	Same as C1	Coupling S1-B to Q3 base (Figure 6-3)
C7	Same as C1	Decoupling, Q2 collector (Figure 6-3)
C8	Same as C1	Coupling, Q2 collector to Q4 base (Figure 6-3)
C9	Same as C1	Bypass, Q2 emitter (Figure 6-3)
C10	Same as C1	Bypass, Q3 emitter (Figure 6-3)
C11	Same as C1	Coupling, Q3 collector to Q5 base (Figure 6-3)
C12	CAPACITOR, FIXED, ELECTROLYTIC: 120 uf, 10 vdc working, solid tant. cap., +10% insulating sleeve, part no. CS13AC121M, per MIL-C-26655-2C	Bypass, Q4 emitter (Figure 6-3)
C13	Same as C12	Bypass, Q5 emitter (Figure 6-3)
C14	CAPACITOR, FIXED, ELECTROLYTIC: 20 uf -15% +50%, 60 vdc working, MIL-C-3965, type CL65BK200MP3	Decoupling, Q5 collector (Figure 6-3)

TABLE 7-1. COMPARATOR-CONVERTER GROUP AN/URA-17C,
MAINTENANCE PARTS LIST (Continued)

REF DESIG.	NAME AND DESCRIPTION	LOCATING FUNCTION
C15	CAPACITOR, FIXED, PAPER DIELECTRIC: 0.22 uf +10%, 100 vdc, MIL-C-25/1 type CP05A1KB224K1	Decoupling, Q8 collector (Figure 6-4)
C16	Not Used	
C17	CAPACITOR, FIXED, ELECTROLYTIC: 50 uf -15% +50%, 60 vdc working, MIL-C-3965-4C type CL65BK500MP3	P/O axis restorer network (Figure 6-4)
C18	Same as C17	P/O axis restorer network (Figure 6-4)
C19	Same as C17	P/O axis restorer network (Figure 6-4)
C20	Same as C17	P/O axis restorer network (Figure 6-4)
C21	CAPACITOR, FIXED, PAPER DIELECTRIC: 0.047 uf, 200 vdc, MIL-C-25/1 type CP05A1KC473K1	Bypass, Q17 collector (Figure 6-3)
C22	CAPACITOR, FIXED, ELECTROLYTIC: 22 uf -15% +50%, 100 vdc, MIL-C-3965 type CL65BN220MP3	P/O -48v power supply filter network (figure 6-4)
C23	Same as C22	P/O -48v power supply filter network (Figure 6-4)
C24	Same as C22	P/O -48 v power supply filter network (Figure 6-4)
C25	Not Used	
C26	Same as C17	P/O -48 v power supply filter network (Figure 6-4)
C27A-B	CAPACITOR, FIXED, PAPER DIELECTRIC: dual section; 0.1 uf +20%, 1000 vdc working per section; MIL-C-25 type CP54B4EG104V1	P/O -560 v power supply filter network (Figure 5-1)
C28	Same as C22	P/O +48 v power supply filter network (Figure 6-4)
C29	CAPACITOR, FIXED, MICA DIELECTRIC: 430 uuf -5% 500 vdc; MIL-C-5B, type CM15E431KN3	P/O RC network for Q22 (Figure 6-4)
C30	Same as C14	P/O +48 v power supply filter network (Figure 6-4)
C31A-B	Same as C27A-B	P/O -560 v power supply filter network (Figure 5-1)
C32	Same as C1	P/O biasing RC network for Q11 (Figure 6-4)
DS1	LAMP, GLOW: 0.04 watt, T-3-1/4 bulb; MIL-L-15098B type NE-51	Power on-off indicator (Figure 5-1)
E1	TERMINAL STUD: silver plated brass term; 39/64 in. lg by 1/4 in. hex base; No. 6-32 threaded ceramic base; 2,500 RM S breakdown voltage at 60 cps; Electronic Molding part No. 2013-91-1	Grounded input center tap (Figure 2-6)

TABLE 7-1. COMPARATOR-CONVERTER GROUP AN/URA-17C,
MAINTENANCE PARTS LIST (Continued)

REF DESIG.	NAME AND DESCRIPTION	LOCATING FUNCTION
E2	CLAMP, CABLE AN3057-6	Secure cables to connectors
FL1	FILTER, BANDPASS: 2000 cps +50 cps operating freq; 8000 ohms +5% input/output impedance at 2000 cps; four terminals; 2-1/4 in. lg by 2-1/4 in. h by 1-3/4 in. w; Orion Spec Control dwg D-031705-68	Wideband filter, input to S1-A (Figure 5-1)
FL2	FILTER, BANDPASS: peaked at 800 cps +40 cps and 1200 cps +49 cps with crossover at 1000 cps +15 cps, four terminals 2-1/4 in lg by 1-3/4 in. h by 1-1/2 in w; Orion Spec Control dwg D-030602-65	Narrow-shift discriminator between Q1 and Q2 or Q3 (Figure 5-1)
FL3	FILTER, BANDPASS: peaked at 1150 cps +100 cps and 2850 cps +150 cps with crossover at 2000 cps +40 cps; four terminals; 2-1/4 in. lg by 1-3/4 in h by 1-1/2 in w; Orion Spec Control dwg D-031705-66; Transonic Inc., type TS-5216	Wide-Shift discriminator between Q1 and Q2 or Q3 (Figure 5-1)
FL4	FILTER, BANDPASS, LOW PASS: section A: 45 cps cutoff frequency; 2 db or less insertion loss at 15 cps; 18 db at 140 cps; 50 db min at 560 cps; 65 db at 1500 cps to 8 kc; 20 k +20% input and output impedance at 5 cps; Section B: 175 cps cutoff frequency, 2 db or less insertion loss at 15 cps; 18 db at 560 cps; 50 db at 2240 cps; 65 db at 4 kc to 8 kc; Orion Spec Control dwg D-030602-67	Keying filter at input to Q6 (Figure 5-1)
F1	FUSE, CARTRIDGE: Silver plated, MS90079-18-1 type F03GR500B	AC line fuse (Figure 5-1)
F2	Same as F1	AC line fuse (Figure 5-1)
J1	CONNECTOR, RECEPTACLE, ELECTRICAL: 15 contacts, gold plated; low loss plastic dielectric; brass body, irridite finish; Cannon Electric Co. part No. DAM-15P	Distribution jack on CV-483C/URA-17 chassis (Figure 5-1)
J2	CONNECTOR, RECEPTACLE, ELECTRICAL: three No. 16 female contacts, low loss plastic dielectric insulation; box type aluminum alloy body; cad plate and chromate finish; MS3102A14S-7S; MIL-C-5015	AUDIO INPUT connector on cable receptacle panel (Figure 2-4)
J3	CONNECTOR, RECEPTACLE, ELECTRICAL: three No. 16 male contacts, low loss plastic dielectric insulation; box type aluminum alloy body; cad plate and chromate finish; MS3102A14S-7P; MIL-C-5015	POWER input connector on cable receptacle panel (Figure 2-4)
J4	CONNECTOR, RECEPTACLE, ELECTRICAL: MIL-G-3608 type UG-1094/U	DIV. A connector for comparator interconnection (Figure 2-4)
J5	Same as J4	DIV. B connector for comparator interconnection (Figure 2-4)
J6	CONNECTOR, RECEPTACLE, ELECTRICAL: two No. 16 male contacts, low loss plastic dielectric; box type aluminum alloy body; cad plate and chromate finish; No. MS3102A14S-9P	TTY OUTPUT connector. Loop keyer output to TTY (Figure 2-4)
J7	Same as J4	REMOTE TUNING IND. connector to remote tuning indicator (Figure 2-4)

TABLE 7-1. COMPARATOR-CONVERTER GROUP AN/URA-17C,
MAINTENANCE PARTS LIST (Continued)

REF. DESIG.	NAME AND DESCRIPTION	LOCATING FUNCTION
P1	CONNECTOR, PLUG, ELECTRICAL: 15 contacts, gold plated; low loss plastic dielectric; brass body, iridite finish; Cannon Electric Co. part No. DAM-15S	Connects J1 to external cable receptacle panel (Figure 5-1)
Q1	TRANSISTOR: germanium, PNP; Sylvania Electric Products Inc., type JAN2N526; MIL-S-19500	Audio amplifier (Figure 6-3)
Q2	Same as Q1	1st mark amplifier (Figure 6-3)
Q3	Same as Q1	1st space amplifier (Figure 6-3)
Q4	TRANSISTOR: JAN2N1041; MIL-S-19500	2nd mark amplifier (Figure 6-3)
Q5	Same as Q4	2nd space amplifier (Figure 6-3)
Q6	TRANSISTOR: silicon, NPN; MIL-T-19500/37A type JAN2N333	DC amplifier (Figure 6-4)
Q7	Same as Q6	DC amplifier (Figure 6-4)
Q8	Same as Q6	DC amplifier (Figure 6-4)
Q9	Same as Q6	DC amplifier (Figure 6-4)
Q10	TRANSISTOR: silicon, NPN; Texas Instrument Corp., type JAN2N657; MIL-S-19500/74C	DC amplifier (Figure 6-4)
Q11	TRANSISTOR: germanium, NPN; Texas Instrument Corp., type JAN2N336; MIL-S-19500	Mark lock-up control (Figure 6-4)
Q12	TRANSISTOR: Silicon, NPN; Texas Instrument Corp., type JAN2N497; MIL-S-19500/74C	Mark lock-up switching (Figure 6-4)
Q13	Same as Q11	P/O dc limiter (Figure 6-3)
Q14	TRANSISTOR: germanium, PNP; Sylvania Electric Products Inc., type JAN2N328A; MIL-S-19500/115	P/O dc limiter (Figure 6-3)
Q15	Same as Q14	P/O dc limiter (Figure 6-3)
Q16	Same as Q6	P/O dc limiter (Figure 6-3)
Q17	Same as Q10	P/O loop keyer (Figure 6-3)
Q18	Same as Q10	P/O loop keyer (Figure 6-3)
R1	RESISTOR, FIXED, COMPOSITION: 5600 ohms +5%, 1/2 w; MIL-R-11, type RC20GF562J; part No. MS35043-105	Impedance matching (Figure 6-3)

TABLE 7-1. COMPARATOR-CONVERTER GROUP AN/URA-17C,
MAINTENANCE PARTS LIST (Continued)

REF. DESIG.	NAME AND DESCRIPTION	LOCATING FUNCTION
R2	RESISTOR, FIXED, COMPOSITION: 10k +10%, 1/2 w; MIL-R-11 type RC20GF103K; part No. MS35043-19	Base bias, Q1 (Figure 6-3)
R3	RESISTOR, FIXED, COMPOSITION: 47k, +10%, 1/2 w; MIL-R-11, type RC20GF473K; part No. MS35043-23	Base bias, Q1 (Figure 6-3)
R4	RESISTOR, VARIABLE, COMPOSITION: 10k, +10%, 2w; single section; MIL-R-94/5 type RV4NAYSD103C	LEVEL control, variable collector load, Q1 (Figure 6-3)
R5	RESISTOR, FIXED, COMPOSITION: 680 ohms +10%, 1/2 w; MIL-R-11, type RC20GF681K; part No. MS35043-12	Decoupling -26 v (Figure 6-3)
R6	RESISTOR, FIXED, COMPOSITION: 120 ohms +10%, 1/2 w; MIL-R-11, type RC20GF121K; part No. MS35043-198	Degeneration, Q1 emitter (Figure 6-3)
R7	RESISTOR, FIXED, COMPOSITION: 3.9k +10%, 1/2 w; MIL-R-11, type RC20GF392K; part No. MS35043-207	Emitter bias, Q1 (Figure 6-3)
R8	RESISTOR, FIXED, COMPOSITION: 18k +10%, 1/2 w; MIL-R-11, type RC20GF183K; part No. MS35043-211	Impedance matchine (Figure 6-3)
R9	Same as R8	Impedance matching (Figure 6-3)
R10	Same as R8	Impedance matchine (Figure 6-3)
R11	RESISTOR, FIXED, COMPOSITON: 22k +10%, 1/2 w; MIL-R-11, type RC20GF223K; part No. MS35043-21	Base bias, Q2 (Figure 6-3)
R12	RESISTOR, FIXED, COMPOSITION: 6.8k +10%, 1/2 w; MIL-R-11, type RC20GF682K; part No. MS35043-18	Base bias, Q2 (Figure 6-3)
R13	Same as R12	Base Bias, Q3 (Figure 6-3)
R14	Same as R11	Base bias, Q3 (Figure 6-3)
R15	RESISTOR, FIXED, COMPOSITION: 1.5k +10%, 1/2 w; MIL-R-11, type RC20GF152K; part No. MS35043-14	Decoupling, -26 v line (Figure 6-3)
R16	Same as R15	Collector load, Q2 (Figure 6-3)
R17	RESISTOR, VARIABLE, COMPOSITION: 2500 ohms; MIL-R-94A type RV6LAYS A252A	SPACE GAIN control, Q3 emitter (Figure 5-1)
R18	Same as R15	Collector load, Q3 (Figure 6-3)
R19	RESISTOR, FIXED, COMPOSITION: 470 ohms +10%, 1/2 w; MIL-R-11, type RC20GF471K; part No. MS35043-11	Base bias, Q4 (Figure 6-3)
R20	RESISTOR, FIXED, COMPOSITION: 1.8k +10%, 1 W; MIL-R-11, type RC32GF182K; part No. MS35044-225	Degenerative feedback, Q4 (Figure 6-3)
R21	Same as R19	Base bias, Q5 (Figure 6-3)
R22	Same as R20	Degenerative feedback, Q5 (Figure 6-3)

TABLE 7-1. COMPARATOR-CONVERTER GROUP 'AN/URA-17C,
MAINTENANCE PARTS LIST (Continued)

REF DESIG.	NAME AND DESCRIPTION	LOCATING FUNCTION
R23	RESISTOR, FIXED, COMPOSITION: 390 ohms +10%, 1/2 w; MIL-R-11, type RC20GF391K	Emitter bias, Q4 (Figure 6-3)
R24	Same as R23	Emitter bias, Q5 (Figure 6-3)
R25	RESISTOR, FIXED, COMPOSITION: 12k +10%, 1/2 w; MIL-R-11, type RC20GF123K; part No. MS35043-210	Mark signal summing resistor (Figure 6-3)
R26	Same as R25	Space signal summing resistor (Figure 6-3)
R27	RESISTOR, FIXED, COMPOSITION: 2200 ohms +10%, 1 w; MIL-R-11, type RC32GF222K	Voltage dropping resistor (Figure 6-3)
R28	Same as R27	Voltage dropping resistor (Figure 6-3)
R29	RESISTOR, FIXED, COMPOSITION: 27k +10%, 1/2 w; MIL-R-11, type RC20GF273K; part No. MS35043-212	Base Biasing, Q6 (Figure 6-4)
R30	RESISTOR, FIXED, COMPOSITION: 15k, +10%, 1/2 w; MIL-R-11, type RC20GF153K; part no. MS35043-20	Emitter bias, Q6 and Q9 (Figure 6-4)
R31	RESISTOR, VARIABLE, COMPOSITION: 1k; MIL-R-11 type RV6LAYS102A	VERT CTR control, variable emitter bias for Q6 and Q9 (Figure 5-1)
R32	Same as R11	Collector load, Q6 (Figure 6-4)
R33	RESISTOR, FIXED, COMPOSITION: 8.2k +10%, 1/2w; MIL-R-11, type RC20GF822K; part No. MS35043-209	Collector load, Q7 (Figure 6-4)
R34	Same as R33	Collector load, Q8 (Figure 6-4)
R35	Same as R30	Emitter bias, Q7 and Q8 (Figure 6-4)
R36	Same as R11	Collector load, Q9 (Figure 6-4)
R37	Same as R25	Base bias, Q9 (Figure 6-4)
R38	RESISTOR, FIXED, COMPOSITION: 3k +10%, 1/2 w; MIL-R-11 type RC20GF333K; part No. MS35043-22	Base bias, Q10 (Figure 6-4)
R39	RESISTOR, VARIABLE, COMPOSITION: 10k; MIL-R-94 type RV6LAYS103A	LIN control, variable; base bias, Q10 (Figure 5-1)
R40	Same as R33	Base bias, Q10 (Figure 6-4)
R41	RESISTOR, FIXED, COMPOSITION: 150k +10%, 1/2 w; MIL-R-11, type RC20GF154K; part No. MS35043-26	Degenerative feedback, Q10 to Q9 (Figure 6-4)
R42	RESISTOR, FIXED, COMPOSITION: 4.7k +10%, 1 w; MIL-R-11 type RC32GF472K; part No. MS35044-17	Collector load, Q10 (Figure 6-4)

TABLE 7-1. COMPARATOR-CONVERTER GROUP AN/URA-17C
MAINTENANCE PARTS LIST (Continued)

REF. DESIG.	NAME AND DESCRIPTION	LOCATING FUNCTION
R43	RESISTOR, FIXED, COMPOSITION: 560 ohms +10%, 1 w; MIL-R-11, type RC32GF561K; part No. MS35044-222	Emitter bias, Q10 (Figure 6-4)
R44	RESISTOR, FIXED, COMPOSITION: 2.2k +10%, 1/2 w; MIL-R-11, type RC20GF222K; part No. MS35043-15	Isolates TP-4 from axis restorer (Figure 6-4)
R45	Same as R11	Axis restorer combining resistor (Figure 6-4)
R46	Same as R11	Axis restorer combining resistor (Figure 6-4)
R47	RESISTOR, FIXED, COMPOSITION: 1.8 meg +10%, 1/2 w; MIL-R-11, type RC20GF185K;	Voltage dropping resistor (Figure 6-4)
R48	Same as R3	P/O biasing RC network for Q11 (Figure 6-4)
R49	Same as R30	Collector load, Q11 (Figure 6-4)
R50	Same as R2	Coupling resistor, Q11 collector to Q12 base (Figure 6-4)
R51	Same as R3	Base bias, Q12 (Figure 6-4)
R52	Same as R33	Collector load, Q12 (Figure 6-4)
R53	RESISTOR, FIXED COMPOSITION: 120k +10%, 1/2 w; MIL-R-11, type RC20GF124K; part No. MS35043-216	Voltage dropping resistor (Figure 6-4)
R54	Same as R38	Comparison resistor (Figure 6-4)
R55	Same as R38	Comparison resistor (Figure 6-3)
R56	RESISTOR, RIXED, COMPOSITION: 2.2 meg +10%, 1/2 w; MIL-R-11, type RC20GF225K; part No. MS35043-33	Base bias, Q13 and Q15 (Figure 6-3)
R57	Same as R56	Base bias Q13 and Q15 (Figure 6-3)
R58	Same as R11	Coupling, comparator to Q13 and Q15 base (Figure 6-3)
R59	RESISTOR, FIXED, COMPOSITION: 2.2k +10%, 2 w; MIL-R-11, type RC42GF222K; part No. MS35045-15	Voltage dropping resistor (Figure 6-3)
R60	RESISTOR, FIXED, COMPOSITION: 220 ohms +10%, 1/2 w; MIL-R-11, type RC20GF221K; part No. MS35043-9	Emitter bias, Q16 (Figure 6-3)
R61	Same as R60	Emitter bias, Q14 (Figure 6-3)
R62	Same as R59	Emitter bias, Q14 (Figure 6-3)

TABLE 7-1. COMPARATOR-CONVERTER GROUP AN/URA-17C
MAINTENANCE PARTS LIST (Continued)

REF. DESIG.	NAME AND DESCRIPTION	LOCATING FUNCTION
R63	RESISTOR, FIXED, COMPOSITION: 680 ohms +10%, 1/2 w; MIL-R-11, type RC20GF681K; part No. MS35043-12	Stabilizes dc limiter by feedback to Q13, Q15 emitters (Figure 6-3)
R64	Same as R15	Collector load, Q14 and Q16 (Figure 6-3)
R65	RESISTOR, FIXED, COMPOSITION: 1k +10%, 1/2 w; MIL-R-11, type RC20GF102K; part No. MS35043-13	Base bias, Q18 (Figure 6-3)
R66	Same as R25	Base bias, Q17 (Figure 6-3)
R67	Same as R27	Current limiting (Figure 6-3)
R68	RESISTOR, WIREWOUND: 125 ohm, 10 w, MIL-R-26	Current limiter for Zener CR27
R69	Not used	
R70	Not Used	
R71	Not Used	
R72	Not Used	
R73	Not Used	
R74	RESISTOR, FIXED, COMPOSITION: 2.2k +10%, 1 w; MIL-R-11, type RC32GF222K; part No. MS35044-15	P/O voltage divider, -48 vdc to -26 vdc (Figure 6-4)
R75	RESISTOR, FIXED, COMPOSITION: 1k +10%, 1 w; MIL-R-11, type RC32GF102K; part No. MS35044-13	P/O voltage divider, -48 vdc to -26 vdc (Figure 6-4)
R76	Same as R11	P/O voltage divider for crt control (Figure 6-3)
R77	RESISTOR, VARIABLE, COMPOSITION: 25k; MIL-R-94/4, type RV6LAYS253A	HORIZ CENTERING control for crt, P/O voltage divider (Figure 5-1)
R78	Same as R11	P/O voltage divider for crt control (Figure 6-3)
R79	Same as R11	P/O voltage divider for crt control (Figure 6-3)
R80	Same as R77	VERT ADJ control for crt, P/O voltage divider (Figure 6-3)
R81	Same as R11	P/O voltage divider for crt control (Figure 6-3)
R82	Same as R56	Voltage divider, V1 sweep (Figure 6-4)
R83	RESISTOR, FIXED, COMPOSITION: 100k +10%, 1/2 w; MIL-R-11, Type RC20GF104K; part No. MS35043-25	Voltage divider, V1 sweep (Figure 6-4)
R84	Same as R3	Current limiting, -560 vdc supply (Figure 6-4)

TABLE 7-1. COMPARATOR-CONVERTER GROUP AN/URA-17C,
MAINTENANCE PARTS LIST (Continued)

REF. DESIG.	NAME AND DESCRIPTION	LOCATING FUNCTION
R85	RESISTOR, WIREWOUND: RW67V40I; MIL-R-26E	Current limiter for Zener CR34
R86	Not Used	
R87	Not Used	
R88	Not Used	
R89	Not Used	
R90	Not Used	
R91	RESISTOR, FIXED, COMPOSITION: 680k +10%, 1/2 w; MIL-R-11, type RC20GF684K; part No. MS35043-30	P/O voltage divider for crt controls (Figure 6-4)
R92	RESISTOR, VARIABLE, COMPOSITION: 500k; MIL-R-94/4, type RV6LAYSAS04A	FOCUS, variable control for V1 (Figure 2-10)
R93	RESISTOR, VARIABLE, COMPOSITION: 1 meg; MIL-R-94/4, type RV6LAYSAS105A	INT, variable control for V1 (Figure 2-10)
R94	RESISTOR, FIXED, COMPOSITION: 820k +10%, 1/2 w; MIL-R-11, type RC20GF824K; part No. MS35043-221	P/O voltage divider for crt controls (Figure 6-4)
R95	Same as R53	Biasing resistor for V1 cathode (Figure 6-4)
R96	Same as R17	MARK GAIN, variable control, Q2 emitter (Figure 5-1)
R97	Same as R94	Base bias for Q6 (Figure 6-4)
S1A-B	SWITCH, ROTARY: First section, two position two shorting movable contacts, six fixed contacts; second section, two position three shorting movable contacts, nine fixed contacts, silver plated brass per QQ-B-613; non-sealed shaft per MIL-S- 3786; solder type terminals on Mycalex sections; Orion Spec Control dwg D-030602-69	SHIFT switch. S1-A selects bandpass filter. S1-B selects discriminator. (Figure 3-1)
S2	SWITCH, ROTARY: One-section, two-position; 30° positioning increments; two shorting moving contacts; six fixed contacts; silver plated brass per QQ-B-613; non-sealed shaft per MIL-S-3786; solder type terminals on Mycalex sections; Orion Spec Control dwg D-030602-71	POLARITY switch. Changes polarity of signal to keying filter. (Figure 3-1)
S3	SWITCH, ROTARY: One-section, two-position; 30° positioning increments; two shorting moving contacts; six fixed contact, silver plated brass per QQ-B-613; non-sealed shaft per MIL-S-3786; solder type terminals on Mycalex sections; Orion Spec Control dwg D-030602-72	SPEED switch. Selects keying filter section. (Figure 3-1)
S4	SWITCH, ROTARY: One-section, three-position 30° positioning increments; two shorting moving contacts; ten fixed contacts, silver plated brass per QQ-B-613; non-sealed shaft per MIL-S-3786; solder type terminals on Mycalex section; Orion Spec Control dwg D-030602-70	FUNCTION switch. Selects input to comparator (Figure 3-1)

TABLE 7-1. COMPARATOR-CONVERTER GROUP AN/URA-17C,
MAINTENANCE PARTS LIST (Continued)

REF. DESIG.	NAME AND DESCRIPTION	LOCATING FUNCTION
S5A-B	SWITCH, SENSITIVE: Single pole, double throw; 5 amp rating at 125/250 vac; plastic body; 0.030 in. contact pre-travel; 0.034 in. contact overtravel; three solder type terminals; composed of two microswitches; Unimax part No. T-483	Cabinet interlock switches (Figure 2-10)
S6	SWITCH, TOGGLE: double pole, single throw; type MS35059-9; MIL-S-3950	POWER switch (Figure 3-1)
TB1	TERMINAL BOARD: Epoxy glass lamin. 3/32 in. thick per MIL-C-18177, type GEE: Orion dwg No. D-030602-184-1,2,3,4	Provides support for component parts (Figure 5-1)
TB2	TERMINAL BOARD: Epoxy glass lamin. 3/32 in. thick per MIL-C-18177, type GEE: Orion dwg No. D-030602-185-1,2,3,4	Provides support for component parts (Figure 5-1)
T1	TRANSFORMER, DISCRIMINATOR: 600 cps to 3600 cps frequency range; shield between pri and sec grounded to case 2-1/16 in. 2-1/4 in. lg, 1-3/4 in. h; Orion Spec Control dwg No. D-030602-61	Coupling from second mark amplifier (Figure 5-1)
T2	Same as T1	Coupling from second space amplifier (Figure 5-1)
T3	TRANSFORMER, POWER, STEP-DOWN: Terminals 1 and 2, 1 and 3, 1 and 4 for input voltages of 105 vac, 115 vac and 125 vac at 47.5 cps to 420 cps; 0.2 amp primary; 59 vrms +3% secondary at 0.25 amp; 2-3/4 in. lg, 2-1/4 in. w, 1-3/4 in. h case; six solder stud terminals; four No. 6-32 by 9/32 in. mtg studs; internal shield between pri and sec grounded to case; Orion Spec Control dwg D-030602-63	Provides power for -48 vdc supply (Figure 5-1)
T4	TRANSFORMER, POWER, STEP-UP, STEP-DOWN: Input terminals 1 and 2, 1 and 3, 1 and 4 for 105 vac, 115 vac and 125 vac input voltages; 47.5 cps to 420 cps; output terminals 5 and 6 for 59 vrms +3% and 85 ma; terminals 7 and 8 for 550 vac +3% and 0.8 ma; terminals 8 and 9 for 6.3 vac +3% and 0.6 amp; 2-3/4 in. lg, 2-1/4 in. w, 1-3/4 in. h case with four 6-32 by 9/32 in. mtg studs; ten solder stud terminals; internal shield between pri and sec grounded to case; Orion Spec Control dwg D-030602-62	Supplies voltage for +48 vdc and -560 vdc supplies (Figure 5-1)
V1	ELECTRON TUBE; Cathode ray; RCA type JAN2BP1 MIL-E-272B	Tuning indicator visual display (Figure 5-1)
XDS1	LAMPHOLDER: type LH64BC-2; MIL-L-3661	Holder for DS1 (Figure 5-1)
XF1	FUSEHOLDER: Extractor post type per MIL-R-19207	Holder for F1 (Figure 5-1)
XF2	Same as XF1	Holder for F2 (Figure 5-1)
XQ1	SOCKET, TRANSISTOR: Three contacts; H.H. Eby part No. 9866-13-6	Socket for Q1 (Figure 6-3)
XQ2	Same as XQ1	Socket for Q2 (Figure 6-3)

TABLE 7-1. COMPARATOR-CONVERTER GROUP AN/URA-17C
MAINTENANCE PARTS LIST (Continued)

REF. DESIG.	NAME AND DESCRIPTION	LOCATING FUNCTION
XQ3	Same as XQ1	Socket for Q3 (Figure 6-3)
XQ4	Same as XQ1	Socket for Q4
XQ5	Same as XQ1	Socket for Q5
XQ6	Same as XQ1	Socket for Q6 (Figure 6-4)
XQ7	Same as XQ1	Socket for Q7 (Figure 6-4)
XQ8	Same as XQ1	Socket for Q8 (Figure 6-4)
XQ9	Same as XQ1	Socket for Q9 (Figure 6-4)
XQ10	Same as XQ1	Socket for Q10 (Figure 6-4)
XQ11	Same as XQ1	Socket for Q11 (Figure 6-4)
XQ12	Same as XQ1	Socket for Q12 (Figure 6-4)
XQ13	Same as XQ1	Socket for Q13 (Figure 6-3)
XQ14	Same as XQ1	Socket for Q14 (Figure 6-3)
XQ15	Same as XQ1	Socket for Q15 (Figure 6-3)
XQ16	Same as XQ1	Socket for Q16 (Figure 6-3)
XQ17	Same as XQ1	Socket for Q17 (Figure 6-3)
XQ18	Same as XQ1	Socket for Q18 (Figure 6-3)
XV1	SOCKET, ELECTRON TUBE: 12 pin, H. H. Eby part No. 9707-10	Socket for V1 (Figure 5-1)
Z1	FILTER-TRANSFORMER NETWORK: Filter and transformer circuits contained in single case, not interconnected; filter bandpass operating freq 1000 cps; 6 db bandwidth 500 cps, 40 db bandwidth 1400 cps; 8 k input and output impedance at 1000 cps; a-f input transformer pri impedance 600 ohms with secondary terminated in 8000 ohm load at 1000 cps; frequency response 600 cps to 3600; 2-1/4 in. lg by 2-1/4 in. w by 1-3/4 in. h; Orion Spec Control dwg D-030602-64	High frequency noise attenuation bandpass filter and impedance matching transformer (Figure 5-1)
P201	Not Used	

TABLE 7-1. COMPARATOR-CONVERTER GROUP AN/URA-17C
MAINTENANCE PARTS LIST (Continued)

REF. DESIG.		NAME AND DESCRIPTION	LOCATING FUNCTION
P203		CONNECTOR, PLUG, ELECTRICAL: Three No. 16 female contacts; low loss plastic dielectric; straight shaped aluminum shell; MS3106A14S-7S	External cable connector for POWER INPUT, J3 (Figure 2-4)
P204		CONNECTOR, PLUG, ELECTRICAL: MIL-C-3608; type UG-88D/U	External cable connector for J4 (Figure 2-4)
P205		Same as P204	External cable connector for J5 (Figure 2-4)
P206		CONNECTOR, PLUG, ELECTRICAL: Two No. 16 female contacts; low loss plastic dielectric; straight shaped aluminum shell; MS3106A14S-9S	External cable connector for TTY OUTPUT, J6 (Figure 2-4)
P207		Same as P204	External cable connector for REMOTE RUNNING IND., J7 (Figure 2-4)

TABLE 7-2. COMPARATOR-CONVERTER GROUP AN/URA-17C,
LIST OF MANUFACTURERS

ABBREVIATION	NAME	ADDRESS
CTC	Cambridge Thermionic Corp.	Cambridge, Mass.
	Cannon Electric Co.	Los Angeles, Calif.
	Cinch Mfg. Co.	Chicago, Ill.
	Delco Radio (Div. General Motors Corp.)	Detroit, Mich.
	Electroboard Corp.	Costa Mesa, Calif.
	General Electric Co.	Schenectady, N. Y.
Amphenol	Amphenol	Chicago, Ill.
Littelfuse	Littelfuse, Inc.	Chicago, Ill.
Oak Mfg.	Oak Mfg. Co.	Chicago, Ill.
Orion	Orion Electronic Corp.	Bronx, N. Y.
	Pacific Semiconductor, Inc.	Culver City, Calif.
RCA	Radio Corporation of America	New York, N. Y.
Sprague	Sprague Electric Co.	New York, N. Y.
	Sylvania Electric Products, Inc.	New York, N. Y.
	Texas Instrument Corp.	Dallas, Texas
Eby	H. H. Eby Co.	Philadelphia, Pa.
	Unimax Switch (Div. W. L. Maxson Corp.)	Wallingford, Conn.

INDEX

SUBJECT	PARA- GRAPH (Figure) *Table	SUBJECT	PARA- GRAPH (Figure) *Table
A		C (Continued)	
Accessory Equipment	1-3, (1-1), *2-1	Electrical	2-5a(2)
Adjustments:		Mechanical	2-5a(1)
After Transistor Replacements	*6-1	Comparator	4-2c(3), (4-5), (5-4)
Cathode-Ray Tube	6-2g	Complement:	
DC Differential Amplifier	6-2i	Diode	*1-6
Mark-Space Amplifier	6-2h	Transistor	*1-5
Power Supply Adjustments	6-2f	Controls:	
Tuning, Single-Receiver Operation	3-2e(1)	Cathode-Ray Tube	*2-3
Tuning, Diversity Operation	3-2e(2)	Front Panel	(3-1), *3-1
Amplifiers:		D	
DC Differential, Functional		Data:	
Operation	4-2c(1)	Quick Reference	1-5
DC Differential, Adjustments	6-2i	Filter and Transformer	
Mark-Space, Functional Operation	4-2b(4)	Resistance	(6-2)
Mark-Spec, Adjustments	6-2h	Shipping	*1-4
Audio Input Lines	2-4c(3)	Daily Check for Correct	
Audio Input Signal	1-5a	Diversity Operation	3-4c, (3-3)
Axis Restorer	4-2c(2)	DC Differential Amplifier:	
B		Adjustments	6-2i, (5-6)
Bandpass Filters:		Functional Operation	4-2c(1)
Functional Operation	4-2b(1), *6-2	DC Limiter	4-2c(4), (5-6)
Tests	6-3d(6)	Detector	4-2b(5), (4-4), (5-4)
Block Diagrams (See Diagrams)		Diagrams:	
C		Comparator, Simplified	(4-5)
Cable Assembly:		Detector, Simplified	(4-4)
Attaching UG-88D/U Connectors		Functional Block	4-1e, (4-2)
to RG-58A/U Coaxial Cable	2-4d(1), (2-7)	Interconnecting	(2-4), (2-5)
Attaching MS Connectors to		Keyer Circuits, Schematic	(5-6)
MCOS-2 Cable	2-4d(2), (2-8)	Loop Keyer and Teletype	
Attaching MS Connectors to		Printer Keying Circuits	(4-6)
TTHFWA - 1-1/2 Cable	2-4d(3), (2-9)	Overall Schematic	(6-5)
Cables, Interconnecting:		Power Supply Schematic	(5-8)
Diversity Operation	(2-5), *2-2	Primary Power Distribution	
Single-Receiver Operation	(2-4), *2-1	Schematic	(5-7)
Cable Receptacle Panel	1-3, (2-6)	Simplified Block	4-1d, (4-1)
Cathode-Ray Tube:		Signal Processing Circuits	
Adjustments	2-5a(2)(a), 6-2g	Schematic	(5-4)
Controls	*2-3	Voltage and Resistance Diagrams:	
Replacement	6-3d(3)	Signal Processing Circuits	(5-3)
Charts:		Keyer	
Functional Section Trouble-		Circuits	(5-5)
Shooting	*5-2, *5-3, *5-4	Wiring	(6-3), (6-4)
System Trouble-Shooting	*5-1	Diode Complement	*1-6
Operator's Routine Check	*3-2	Discriminator:	
Operator's Trouble-Shooting	*3-3	Functional Operation	4-2b(3), (4-3), (6-3)
Chassis Removal	6-3c(1)	Response Curves	(4-3)
Checks:		Tests	6-3d(7), (6-1)
Daily Check for Correct		Diversity Operation	1-2, 3-1c, 3-2g(2)
Diversity Operation	3-4c, (3-3)	E	
		Emergency Maintenance	3-4f

SUBJECT	PARA-GRAPH (Figure) *Table	SUBJECT	PARA-GRAPH (Figure) *Table
E (Continued)		K	
Equipment:		Keyer Circuits	4-2c, (4-2), (5-6)
Accessory	1-3, (1-1), *2-1	Keyer, Loop	4-2c(5), (4-6), (5-6)
Mounting	(2-1), (2-2), (2-3), 2-4b	Keying Filter:	
Supplied	*1-1, (1-1)	Functional Operation	4-2b(6), *6-2
Required but not Supplied	*1-2	Tests	6-3d(7)
Test Equipment Required but not Supplied	*1-3	Keying Speeds, Maximum	1-5c
Similarities	1-6e	Key Part	7-2
Electrical:		L	
Pre-Operational Tests	2-5a(2)(b)	Layout Installation	2-3
Operational Tests	2-5a(2)(c)	Limiter:	
External Tuning Indicator	1-3	DC	4-2c(4), (5-6)
F		Input	4-2b(2), (5-4)
Factory or Field Changes	1-4	List of Manufacturers	*7-2
Failure Report	6-1	Loop Keyer	4-2c(5), (4-6), (5-6)
Filters:		Lowpass Keying Filter	4-2b(6), *6-2, (5-4)
Bandpass, Functional Operation	4-2b(1), *6-2	M	
Bandpass, Tests	6-3d(6), (5-4)	Maintenance:	
Lowpass Keying, Functional Operation	4-2b(6), *6-2	Emergency	3-4f
Lowpass Keying, Tests	6-3d(8), (5-4)	Operator's	3-4
Resistance Data	(6-2)	Maintenance Standards	6-2b
Frequency-Diversity	1-2	Malfuction During Diversity Operation	5-3d(2)
Frequency Shift Method of Communication	3-1b	Malfuction During Single-Receiver Operation	5-3d(1)
Frequencies, Operating	1-5b	Manufacturers, List of	*7-2
Front Panel Controls	(3-1), *3-1	Mechanical Tests	2-5a
Functional Description:		Mark Lock-Up	4-2c(6), (5-4)
Diversity Operation	4-1b	Mark Space Amplifiers:	
Overall Operation	4-1	Adjustments	6-2h, (5-4)
Single-Receiver Operation	4-1c	Functional Operation	4-2b(4)
Fuse Replacement	3-4e	Mounting, Equipment:	
I		AN/URA-17C, Rack-Mounting	2-4b(3)
Indicator Lamp Replacement	3-4d	AN/URA-17C, Table-Mounting	2-4b(1), (2-1)
Indicator, Tuning:		CV-483C/URA-17, Rack-Mounting	2-4b(4), (2-3)
External	1-3	CV-483C/URA-17, Table-Mounting	2-4b(2), (2-2)
Functional Operation	4-2c(7)	O	
Presentations	3-2d, (3-2)	Operating Frequencies	1-5b
Input Signal, af	1-5a	Operator's:	
Input Lines, Audio	2-4c(3)	Check Chart	*3-2
Inspection and Adjustments	2-5	Controls	*3-1, (3-1)
Installation:		Maintenance	3-4
Inspection	2-5	Trouble-Shooting Chart	*3-3
Layout	2-3	Operation:	
Requirements	(2-1), (2-2), (2-3)	Diversity	3-1c, 3-2g(2), 3-3c
Interconnection:		Principles of	4
Cables for Diversity Operation	*2-2, (2-5)		
Cables for Single-Receiver Operation	*2-1, (2-4)		

SUBJECT O (Continued)	PARA- GRAPH (Figure) *Table	SUBJECT R (Continued)	PARA- GRAPH (Figure) *Table
Sequence of Single-Receiver Operational Check	3-2 3-1d, 3-2g(1), 3-3a 2-5b	Rotary Switch Wafer Transformer Transistor Transistor Socket	6-3d(5) 6-3c(2) 6-3d(2) 6-3d(4)
Oscilloscope Patterns, Signal Tracing	*5-5	Report, Failure	6-1
Outline Drawings, Installation	(2-1), (2-2), (2-3)	Reshipment, Preparation for Resistance Data:	2-6 (6-2)
P		Filter and Transformer Transistor	(5-3), (5-5)
Part, Key	7-2	Routine Check Chart, Operator's	*3-2
Parts:		S	
Maintenance, List of Location of	7-2, *7-1 (5-1)	Schematic Diagram:	
Performance Standards	6-2b	Comparator, Simplified	(4-5)
Power Requirements and Distribution	1-5e, 2-2	Keyer Circuits	(5-6)
Power Supplies:		Overall	(6-5)
+48 Volt Supply, Functional Operation	4-2d(1)	Power Supplies	(5-8)
+48 Volt Supply, Adjustment	6-2f(1)	Primary Power Distribution	(5-7)
-48 Volt Supply, Functional Operation	4-2d(2)	Signal Processing Circuits	(5-4)
-48 Volt Supply, Adjustment	6-2f(2)	Teletype Printer DC Keying Relay Circuit, Simplified	(2-11)
-560 Volt Supply, Functional Operation	4-2d(3)	Shipping Data	*1-4
Power Transformer Connections	2-4c(4), (5-8)	Signal Processing Circuits	4-2b, (5-4)
Preparation for Reshipment:		Signal Tracing Oscilloscope Patterns	*5-5
Dismounting Equipment	2-6b	Single-Receiver Operation	3-1d, 3-2g(1)
Packing	2-6c	Space Diversity	1-2
Presentations, Tuning Indicator	(3-2)	Standards	6-2b
Primary Power Distribution Diagram	(5-7)	T	
Principles of Operation	4	Teletype Printer DC Keying Relay Circuit, Simplified	(2-11)
Publications Required but not Supplied	*1-2	Schematic	(6-3), (6-4)
R		Terminal Board Wiring Diagrams	
Rack-Mounting AN/URA-17C	2-4b(3)	Tests:	
Rack-Mounting CV-483C/URA-17	2-4b(4)	Bandpass Filter	6-3d(6)
Receiver Tuning	3-2e	Discriminator	6-3d(7)
Reception :		Electrical, Operational	2-5a(2)(c)
Diversity	3-1c	Electrical, Pre-Operational	2-5a(2)(b)
Single-Receiver	3-1d	Mechanical	2-5a(1)
Reference Data	1-5	Test Points, Location of Transformer and Filter	(5-2)
Removal:		Resistance Data	(6-2)
Chassis	6-3c(1)	Transistor:	
Receptacle Panel	6-3c(4)	Base Data	(5-3), (5-5)
Repair	6	Complement	*1-5
Replacement:		Voltage and Resistance Data	(5-3), (5-5)
Cathode-Ray Tube	6-3d(3)	Trouble-Shooting	
Filter	6-3c(2)	Keyer Circuits	(5-5), (5-6), *5-5, (5-4), *5-3, 5-4c
Fuse	3-4e	Operator's Chart	*3-3
Indicator Lamp	3-4d	System	5-3, *5-1
Printed Circuit Board	6-3c(3)	Power Supplies	*5-4, 5-4d, (5-8)
		Signal Processing Circuits	(5-4), (5-3), *5-5, (5-3), *5-2, 5-4b

SUBJECT	PARA- GRAPH (Figure) *Table	SUBJECT	PARA- GRAPH (Figure) *Table
T (Continued)		T (Continued)	
Test Equipment Required for Malfunction During Diversity Operation	5-2 5-3d(2)	Tuning and Adjustment: Test Equipment Required for	6-2 6-2c
Alfunction During Single Receiver Operation	5-3d(1)	U	
Troubles, Typical	*5-5	Unpacking and Handling	2-1
Tuning Adjustments:		V	
Diversity Operation	3-2e(2)	Voltages, Transistor	(5-3), (5-5)
Single-Receiver Operation	3-2e(1)	W	
Tuning Indicator:		Wiring Diagrams	(6-3), (6-4)
Controls	*2-3, (2-10)		
External	1-3, 2-3		
Functional Operation	4-2c(7)		
Presentations	3-2d, (3-2		
Cathode-Ray Tube Replacement	6-3d(3)		

