

NAVTRA 41048

0502-205-2400

TRAINEE'S GUIDE
for
NAVAL SCHOOLS
TELETYPE MAINTENANCE

CLASS C

VOLUME 3

A-160-0023

A-160-0024

Chief of Naval Technical Training

June 1972

DEPARTMENT OF THE NAVY
CHIEF OF NAVAL TECHNICAL TRAINING
NAVAL AIR STATION
MILLINGTON, TENNESSEE 38054

IN REPLY REFER TO

FOREWORD

1. NAVTRA 41048, Trainee's Guide for Naval Schools, Teletype Maintenance, Class C, Volume 3, is approved for use in the Teletype Maintenance courses A-160-0023 and A-160-0024.
2. This publication supersedes volume 3 of all previous trainee guides developed for the course.
3. Commands are invited to submit explicit comments and recommendations on the contents of this publication to the Chief of Naval Technical Training (N3).



L. D. MARSOLAIS
Captain, USN
Head, Individual Technical
Training Branch

DISTRIBUTION LIST:

COMMANDING OFFICER FLEET TRAINING CENTER NORFOLK, VIRGINIA 23511	350
COMMANDING OFFICER SERVICE SCHOOL COMMAND NAVAL TRAINING CENTER SAN DIEGO, CALIFORNIA 92133	350
COMMANDER NAVAL SHIP SYSTEMS COMMAND (06T) NAVAL SHIP SYSTEMS COMMAND HQ WASHINGTON, D.C. 20360	1
OFFICER IN CHARGE NORFOLK DIVISION SEC 6600 NAVAL SHIP ENGINEERING CENTER NAVAL STATION, BLDG AP-13 NORFOLK, VIRGINIA 23511	1
COMMANDING OFFICER NAVAL PUBLICATIONS AND FORMS CENTER 5801 Tabor Avenue PHILADELPHIA, PENNSYLVANIA 19120	50
OFFICER IN CHARGE NAVAL TRAINING PUBLICATIONS DETACHMENT BLDG 220 WASHINGTON NAVY YARD WASHINGTON, D.C. 20390	2
CHIEF OF NAVAL TECHNICAL TRAINING (N321) NAVAL AIR STATION MEMPHIS (75) MILLINGTON, TENNESSEE 38054	1
COMMANDING OFFICER NAVAL TRAINING SUPPORT COMMAND (Code 20) BLDG 45 PENSACOLA, FLORIDA 32508	1

RECORD OF CHANGES

No.	Authority	Substance	Entered by	Date

CONTENTS

	<u>PAGE</u>
Foreword	i
Distribution List.	ii
Record of Changes.	iii
1-4-1D Signalling Code.	1
1-4-2D Half Duplex TTY Circuit.	2
1-5-1D Terminology #1	3
1-5-2D Terminology #2	4
1-5-3D Terminology #3	5
1-5-4D Terminology #4	6
1-5-5D Terminology #5	7
1-6-1D Gear Power Train	8
1-6-2D Internal Expansion Clutch.	9
2-1-1D Main Shaft and Selector Cam Sleeve Assembly.	10
2-1-2D Selector Clutch Trip Mechanism	11
2-1-3D Range Finder Operation	12
2-1-4D Selecting Mechanism.	13
2-1-5D Selection (Marking).	14
2-1-6D Selection (Spacing).	15
2-1-7D Transfer Mechanism (Marking)	16
2-1-8D Transfer Mechanism (Spacing)	17
2-1-9D Push Lever Reset	18
2-1-10D Common Transfer Lever.	19
2-1-11D Code Bar Clutch Trip	20
2-1-12D Code Bar Shift Mechanism #1.	21
2-1-13D Code Bar Shift Mechanism #2.	22
2-2-1D Clutch Trip Shaft.	23
2-2-2D Configuration of the Typebox	24
2-2-3D Type Box Clutch.	25
2-2-4D Vertical Positioning	26
2-2-5D Vertical Positioning Lock Levers	27
2-3-1D Reversing Slide.	28
2-3-2D Horizontal Positioning	29
2-3-3D Horizontal Positioning Lock Lever.	30
2-3-4D Horizontal Motion Stop Slides.	31
2-3-5D Horizontal Motion Stop Slides Positioning.	32
2-3-6D Ribbon Oscillation	33
2-3-7D Ribbon Feed.	34
2-3-8D Ribbon Reverse	35
2-3-9D Spacing Trip Mechanism	36
2-3-10D Spacing Feed Pawls	37
2-3-11D Spacing Mechanism #1	38
2-3-12D Spacing Mechanism #2	39
2-3-13D Spacing Cut-Out.	40

CONTENTS (continued)

PAGE

2-4-1D	Printing Mechanism	41
2-4-2D	Reset Bail (initial position).	42
2-4-3D	Reset Bail (final position).	43
2-4-4D	Stripper Blade	44
2-4-5D	Carriage Return Mechanism #1	45
2-4-6D	Carriage Return Mechanism #2	46
2-4-7D	Local Carriage Return.	47
2-4-8D	Spacing Suppression.	48
2-4-9D	Signal Bell Function	49
2-4-10D	Letters/Figures Shift Slides	50
2-4-11D	Figures Shift.	51
2-4-12D	Letters Shift.	52
2-4-13D	Double Line Feed	53
2-4-14D	Line Feed Function	54
2-4-15D	Line Feed Mechanism.	55
2-4-16D	Single Line Feed	56
2-4-17D	Local Line Feed.	57
2-4-18D	Manual Line Feed	58
2-4-19D	Automatic Line Feed on Carriage Return	59
2-4-20D	Universal Mechanism.	60
2-4-21D	Automatic Carriage Return and Line Feed.	61
2-4-22D	Remote Keyboard Lock Function.	62
2-4-23D	Lockbar Mechanism.	63
3-1-1D	Lockball Mechanism	64
3-1-2D	Keyboard Mechanism #1.	65
3-1-3D	Keyboard Mechanism #2.	66
3-1-4D	Signal Generator Clutch Trip	67
3-1-5D	Code Bar Selection	68
3-1-6D	Transfer Lever Mechanism	69
3-1-7D	Locking Bail	70
3-1-8D	Signal Contact Box (Marking)	71
3-1-9D	Signal Contact Box (Spacing)	72
3-1-10D	Keyboard Reset #1.	73
3-1-11D	Keyboard Reset #2.	74
3-1-12D	Disengaging Signal Generator Clutch.	75
3-1-13D	Clutch Trip Delay.	76
3-1-14D	Repeat Key Operation	77
3-1-15D	Line Break Mechanism	78
3-1-16D	Local Keyboard Lock.	79
3-1-17D	Keyboard Unlock.	80
3-1-18D	Character Counter (Counting)	81
3-1-19D	Character Counter (Resetting).	82
4-1-1D	Blocking Bail Operation.	83
4-1-2D	Bell Crank Operation	84
4-1-3D	Keyboard Control Selection Lever (K-KT).	85

CONTENTS (continued)

	<u>PAGE</u>
4-1-4D Keyboard Control Selection Lever (T)	86
4-1-5D Perforator Function Clutch Trip.	87
4-1-6D Punch Slide Reset Bail	88
4-1-7D Punch Mechanism #1	89
4-1-8D Toggle Bail Operation.	90
4-1-9D Punch Mechanism #2	91
4-2-1D Tape Feed and Feed hold Spacing.	92
4-3-1D Positioning Push Bars (Marking).	93
4-3-2D Positioning Push Bars (Spacing).	94
4-3-3D No. 5 Pulse Beam	95
4-3-4D Typewheel.	96
4-3-5D Operating Blade.	97
4-3-6D Axial Positioning #1	98
4-3-7D Axial Positioning #2	99
4-3-8D Axial Correcting	100
4-3-9D Rotary Positioning	101
4-3-10D Cross Link Operation	102
4-3-11D Rotary Correcting.	103
4-3-12D Function Blade Sensing	104
4-3-13D Toggle Link Operation.	105
4-3-14D Letters/Figures Shift #1	106
4-3-15D Letters/Figures Shift #2	107
4-4-1D Printing Mechanism	108
4-4-2D Ribbon Oscillation	109
4-4-3D Ribbon Feed.	110
4-4-4D Ribbon Reverse	111
4-4-5D Power Drive Backspace.	112
4-5-1D Reperforator Selector Mechanism.	113
4-5-2D Reperforator Function Clutch Trip.	114
5-1-1D TD Clutch Trip	115
5-1-2D TD Tape Feed	116
5-1-3D TD Tape Feed (Rear View)	117
5-1-4D Tape Sensing (Mark)	118
5-1-5D Tape Sensing (Space)	119
5-1-6D Transfer Bail Stabilizer Mechanism	120
5-1-7D Start/Stop Mechanism and Tape Out Sensing	121
5-1-8D Tight or Tangled Tape	122
6-2-1D AC Circuits (AN/UGC-6K)	123
6-3-1D DC Circuits (AN/UGC-6K)	124
6-4-1D AC and DC Circuits of Reperforator	125
6-5-1D SMD Block Diagram	126
6-6-1D Teletype Panel Block Diagram	127
7 1-1D Teletype Distortion.	128
8-2-1D Codebar Mechanism	129

CONTENTS (continued)	<u>PAGE</u>
8-2-2D Universal Mechanism.	130
8-2-3D Contact Mechanism.	131
8-2-4D Reset Mechanism #1	132
8-2-5D Reset Mechanism #2	133
8-2-6D Repeat Mechanism	134
8-2-7D Line Break Mechanism	135
8-2-8D Local Line Feed.	136
8-2-9D Local Carriage Return.	137
8-2-10D Distributor Cam Sleeve	138
8-2-11D Distributor Clutch Trip Mechanism.	139
8-2-12D Distributor Mechanism.	140
8-2-13D 3 Speed Gear Mechanism	141
8-3-1D AC Circuits (AN/UGC-20).	142
8-3-2D DC Circuits (AN/UGC-20).	143
Location of Electrical Componenets	
Cabinet	144
Automatic Typer and T.D..	145
Keyboard.	146
Upper ESU	147
Reperforator and Lower ESU.	148

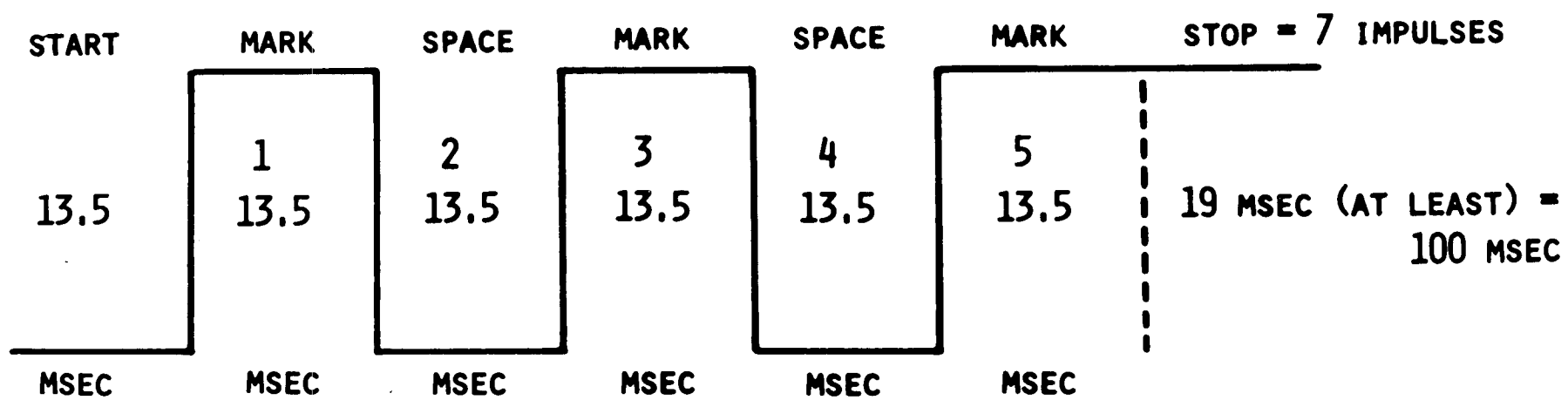

MOD 28 ASR-AN/UGC-6K- SIGNALLING CODE

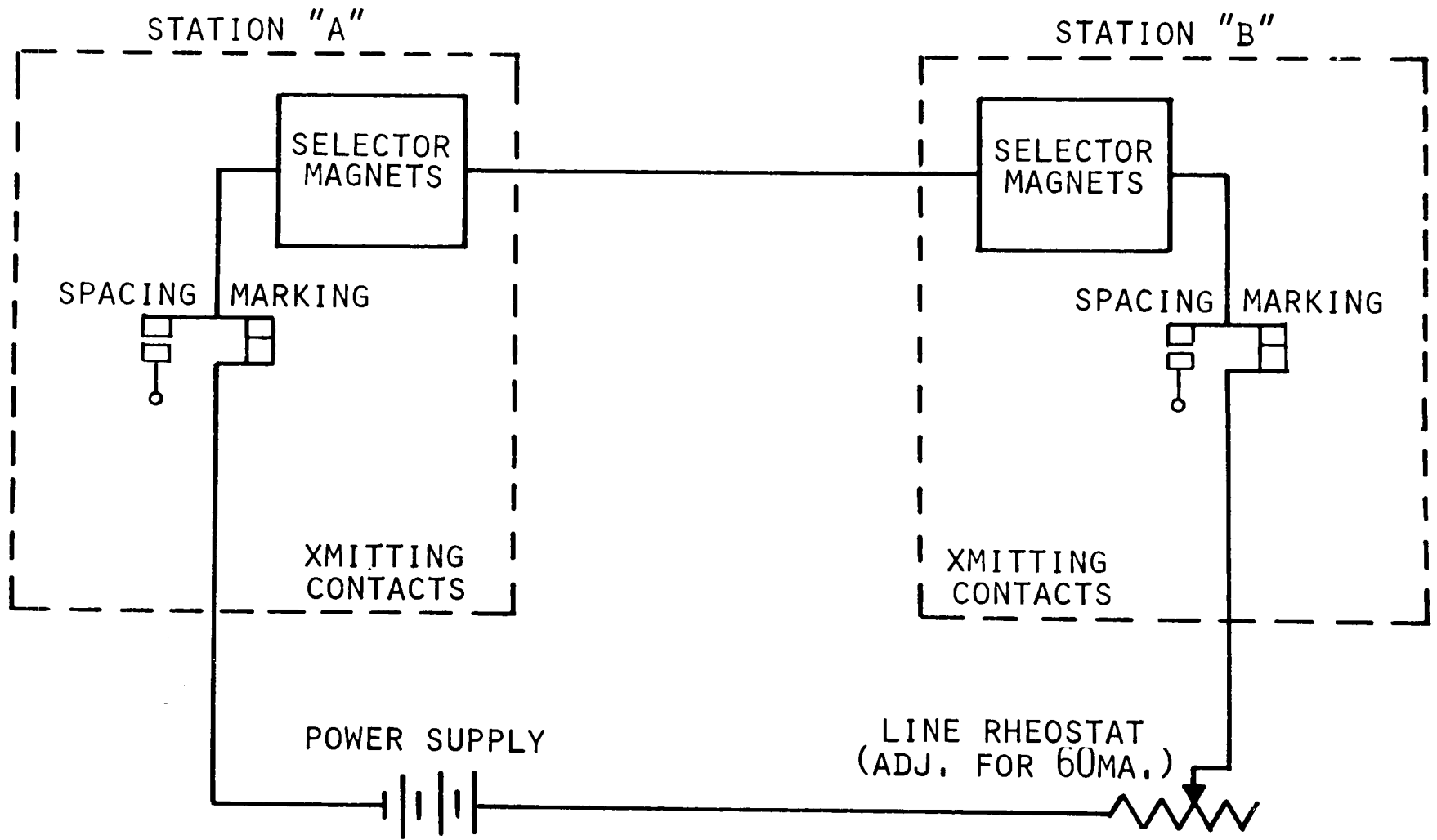

MOD 28 ASR-AN/UGC-6K- HALF DUPLEX TTY CIRCUIT

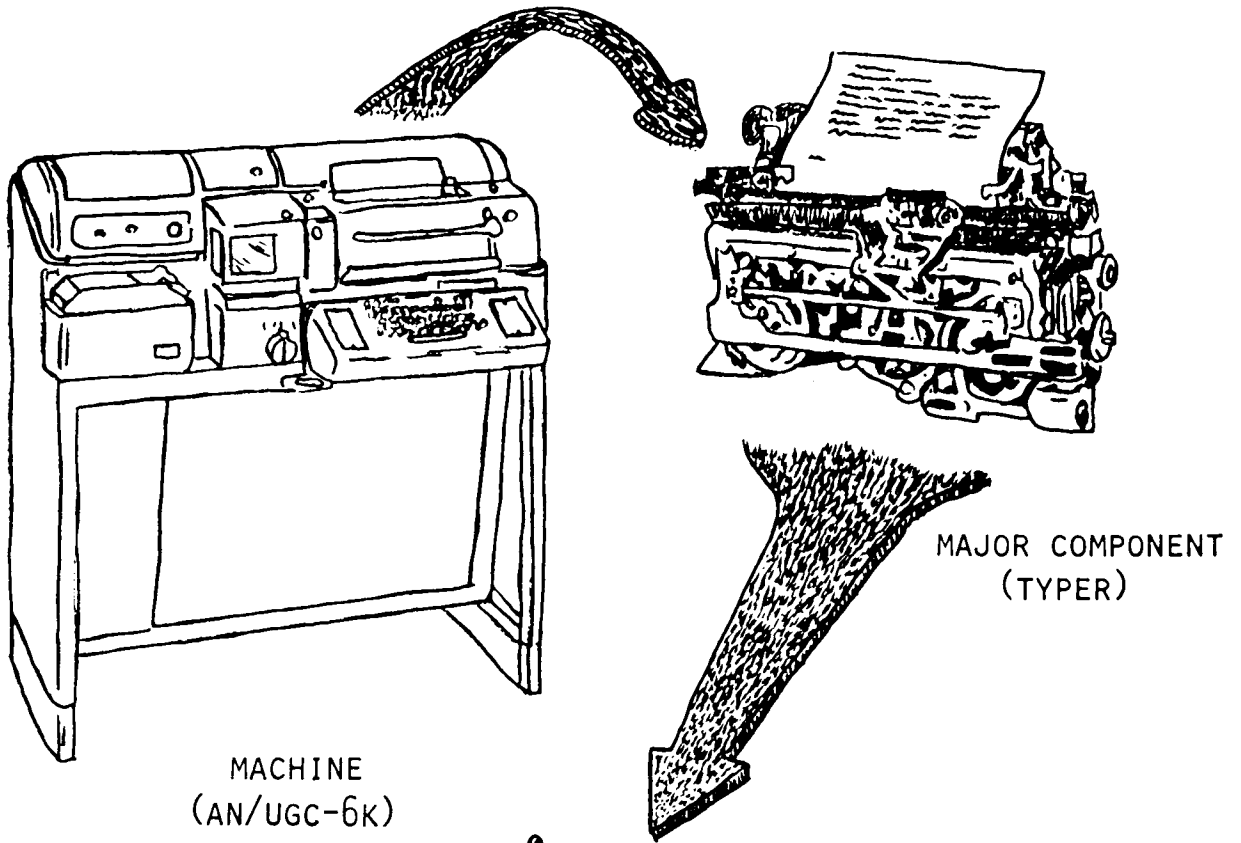

MACHINE
(AN/UGC-6K)

MAJOR COMPONENT
(TYPER)

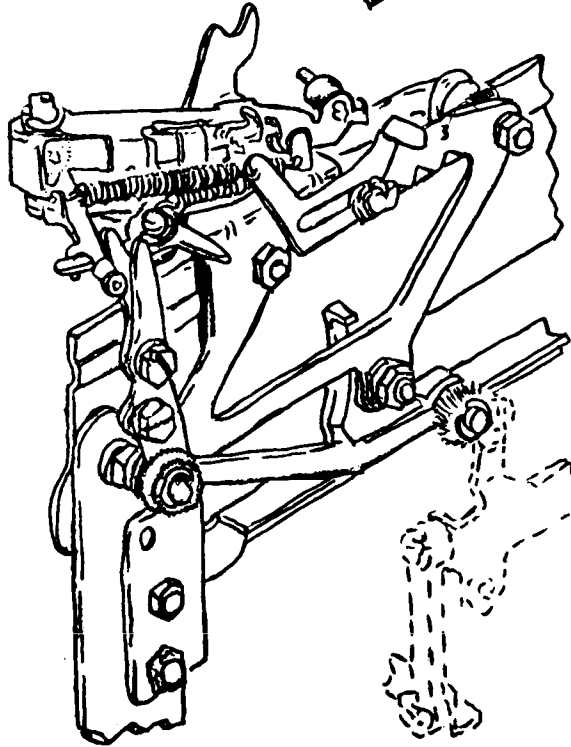

TRAIN OF PARTS
(PRINTING MECHANISM)

MOD 28 ASR-AN/UGC--6K TERMINOLOGY (#1)

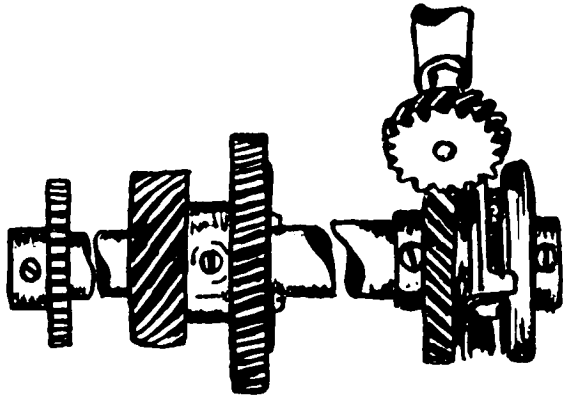

GEARS

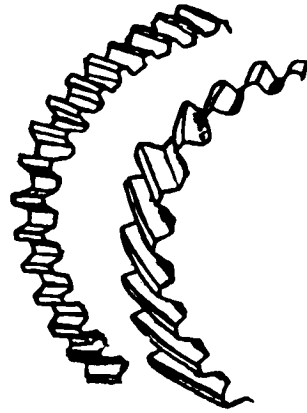

SPUR

HELICAL

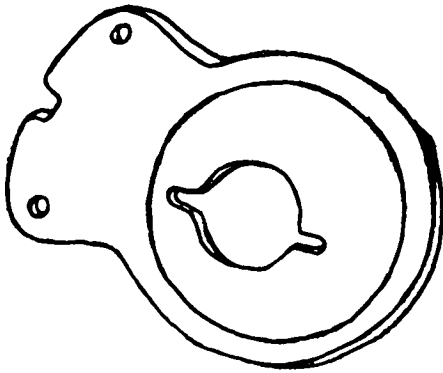

ECCENTRIC

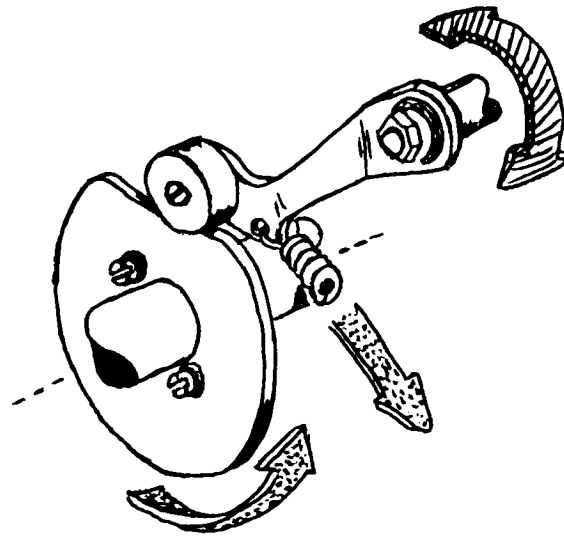

CAM



COIL

SPRINGS

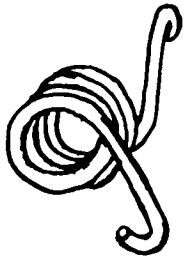

TORSION

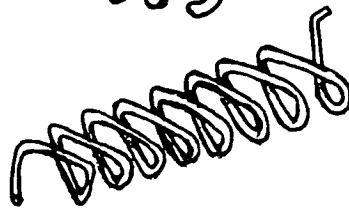

COMPRESSION

MOD 28 ASR-AN/UGC--6K TERMINOLOGY (#2)

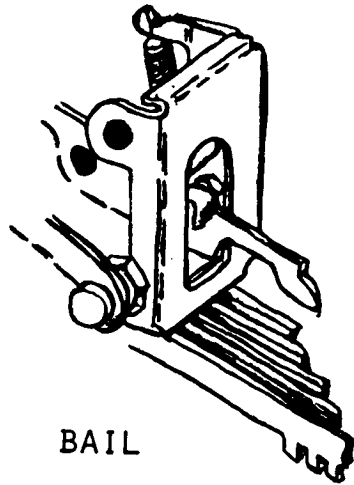

BAIL

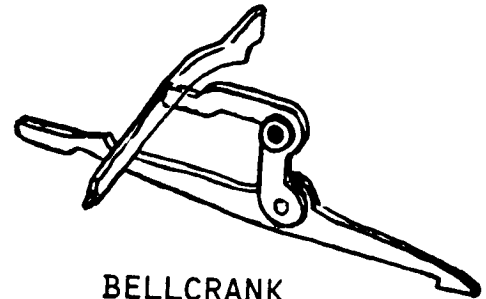

BELLCRANK

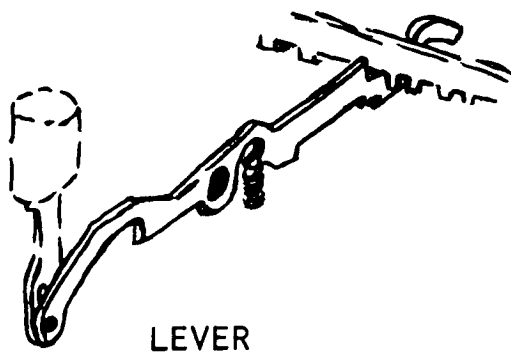

LEVER

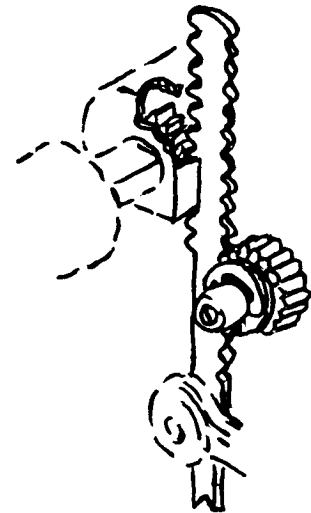

RACK

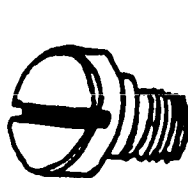

SHOULDER SCREW

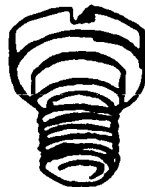

ECCENTRIC SCREW

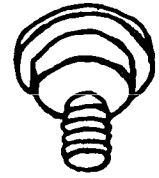
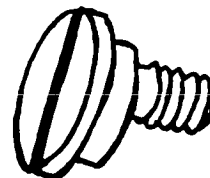

MOD 28 ASR-AN/UGC--6K TERMINOLOGY (#3)

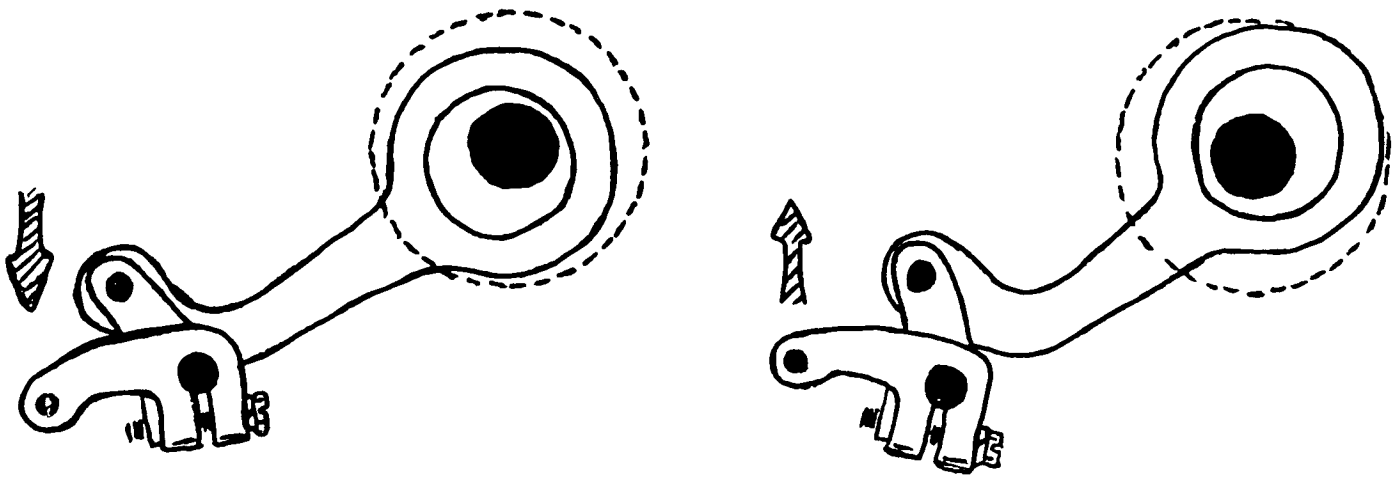
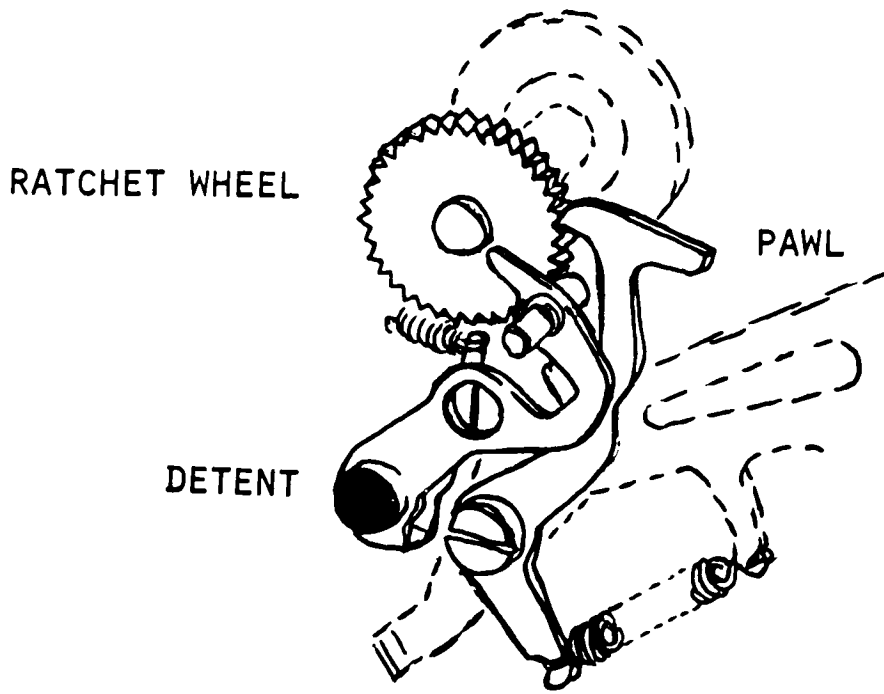

ECCENTRIC AND FOLLOWER

MOD 28 ASR-AN/UGC-6K TERMINOLOGY (# 4)

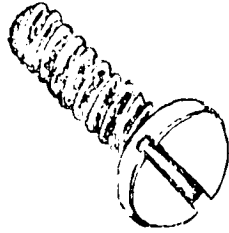

ROUND HEAD SCREW

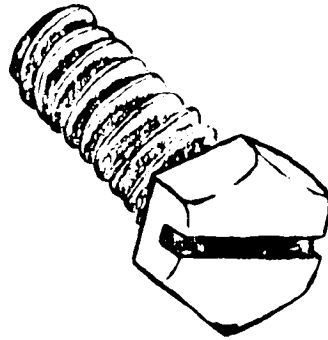

HEXAGON HEAD SCREW

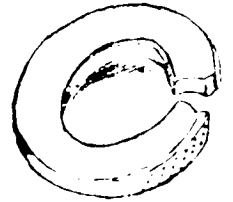

LOCK WASHER

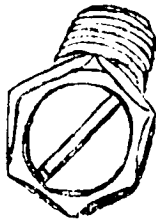

HEXAGON HEAD SCREW

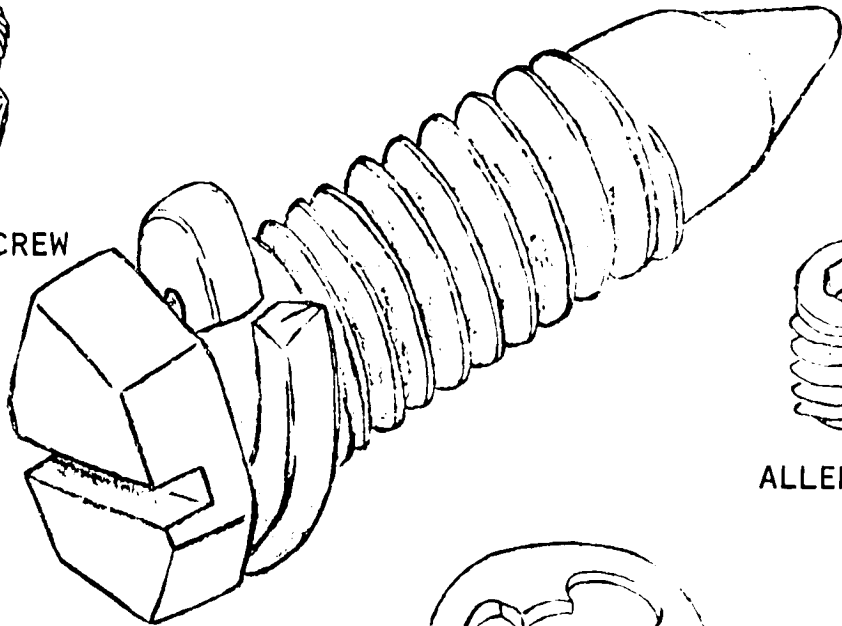

PILOT SCREW

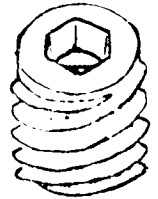

ALLEN SCREW

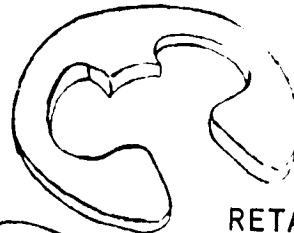

RETAINER RING
(C CLAMP)

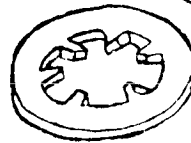

LOCK WASHER
(STAR)

MOD 28 ASR-AN/UGC-6K TERMINOLOGY (#5)

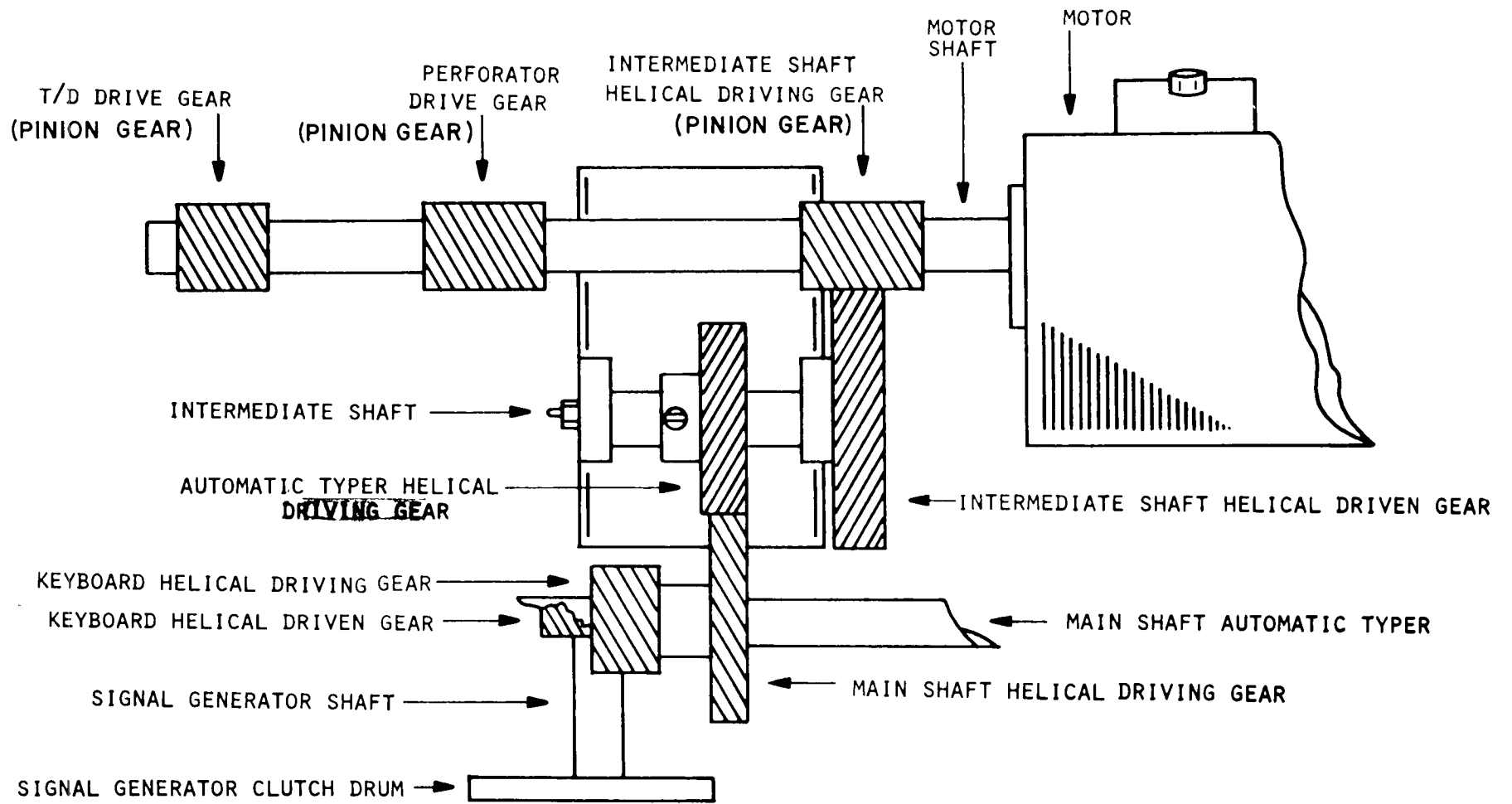

MOD 28 ASR-AN/UGC-6K GEAR POWER TRAIN

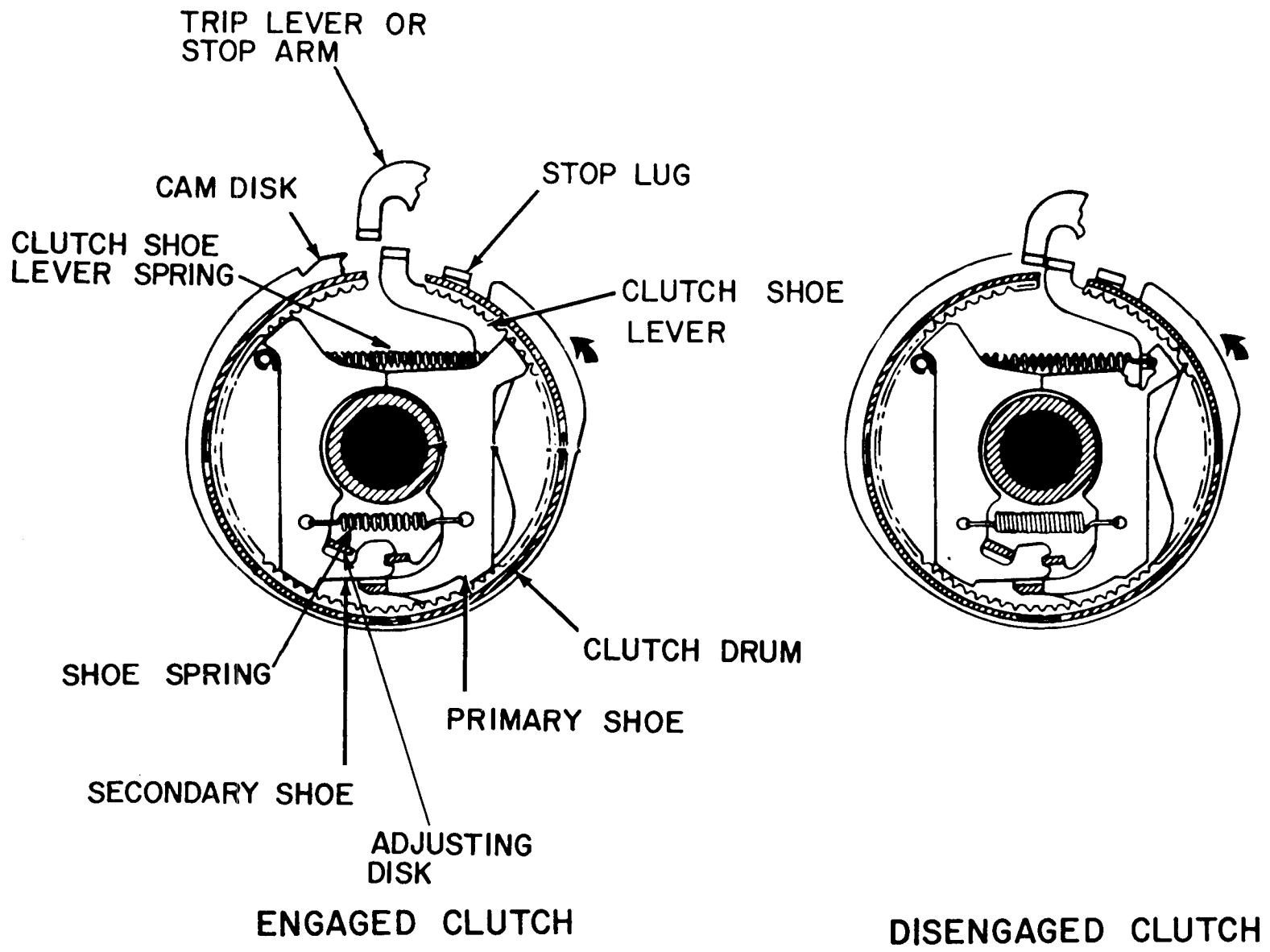

MOD 28 ASR-AN/UGC-6K INTERNAL EXPANSION CLUTCH

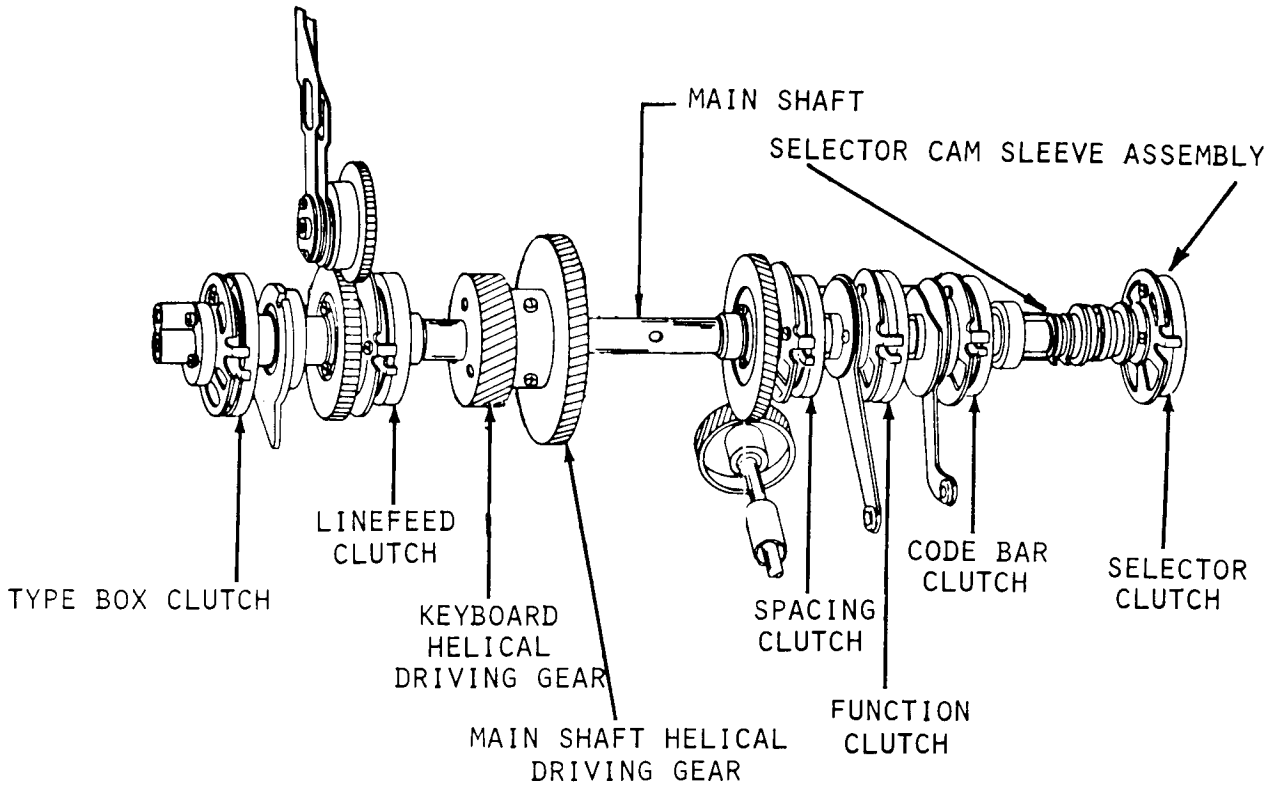

MAIN SHAFT

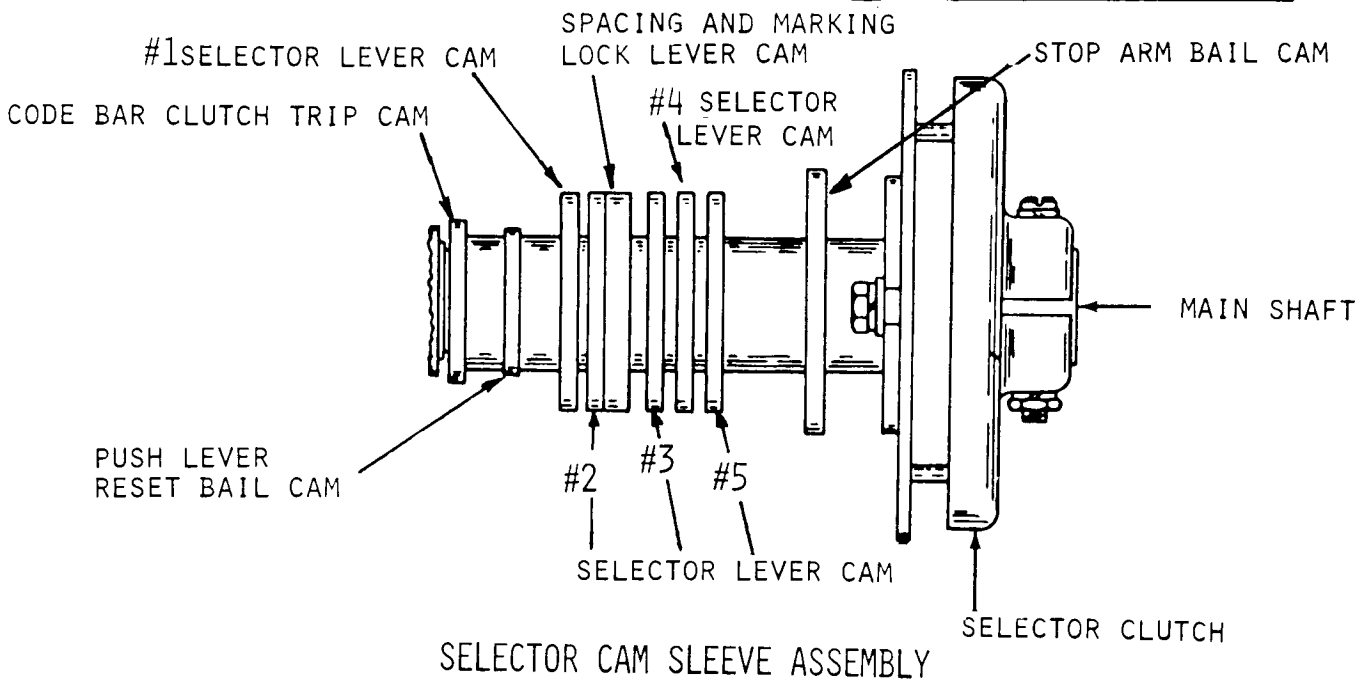

MOD 28 ASR -AN/UGC-6K MAIN SHAFT AND SELECTOR CAM SLEEVE ASSEMBLY

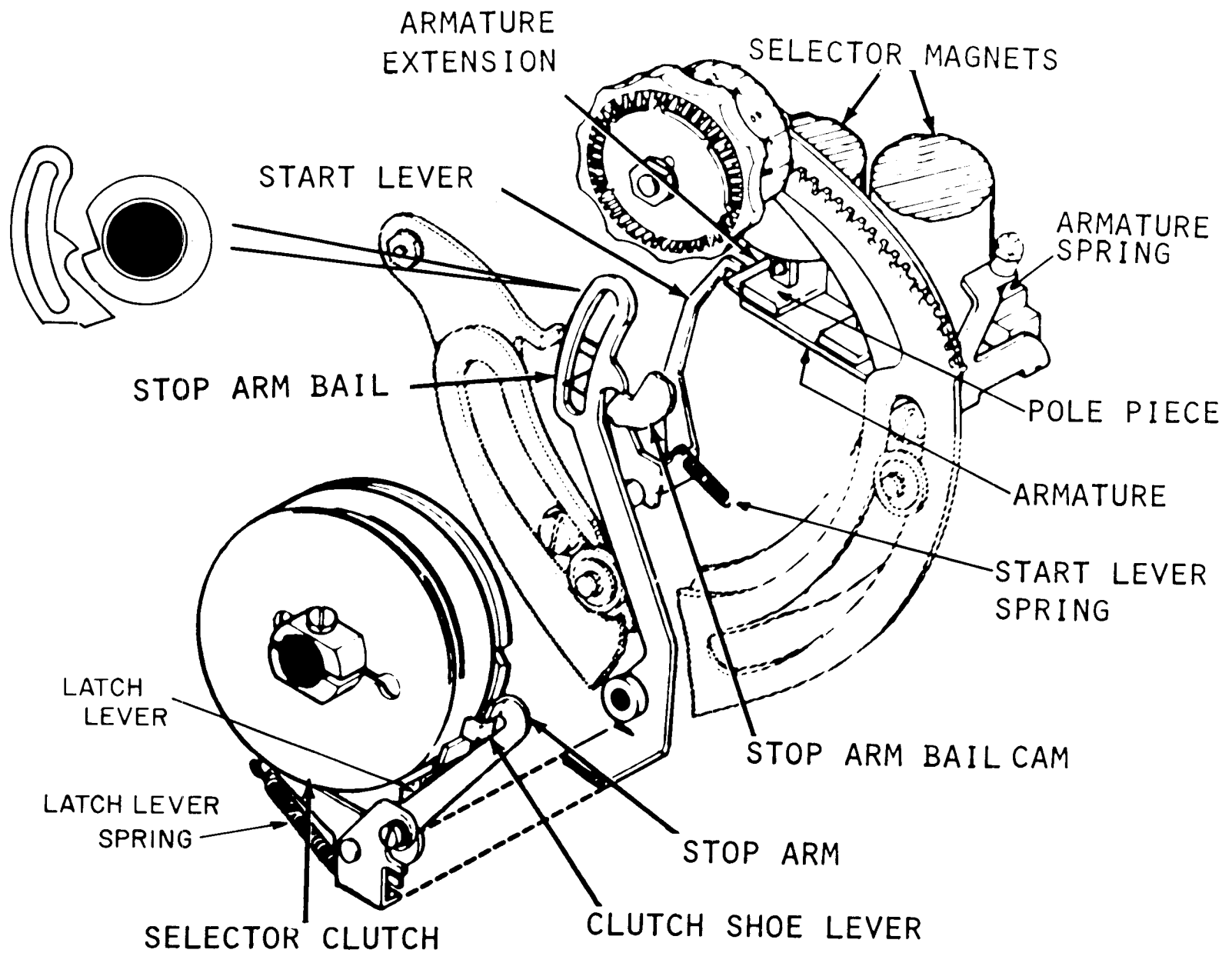

MOD 28 ASR-AN/UGC-6K- SELECTOR CLUTCH TRIP MECHANISM (RIGHT VIEW)

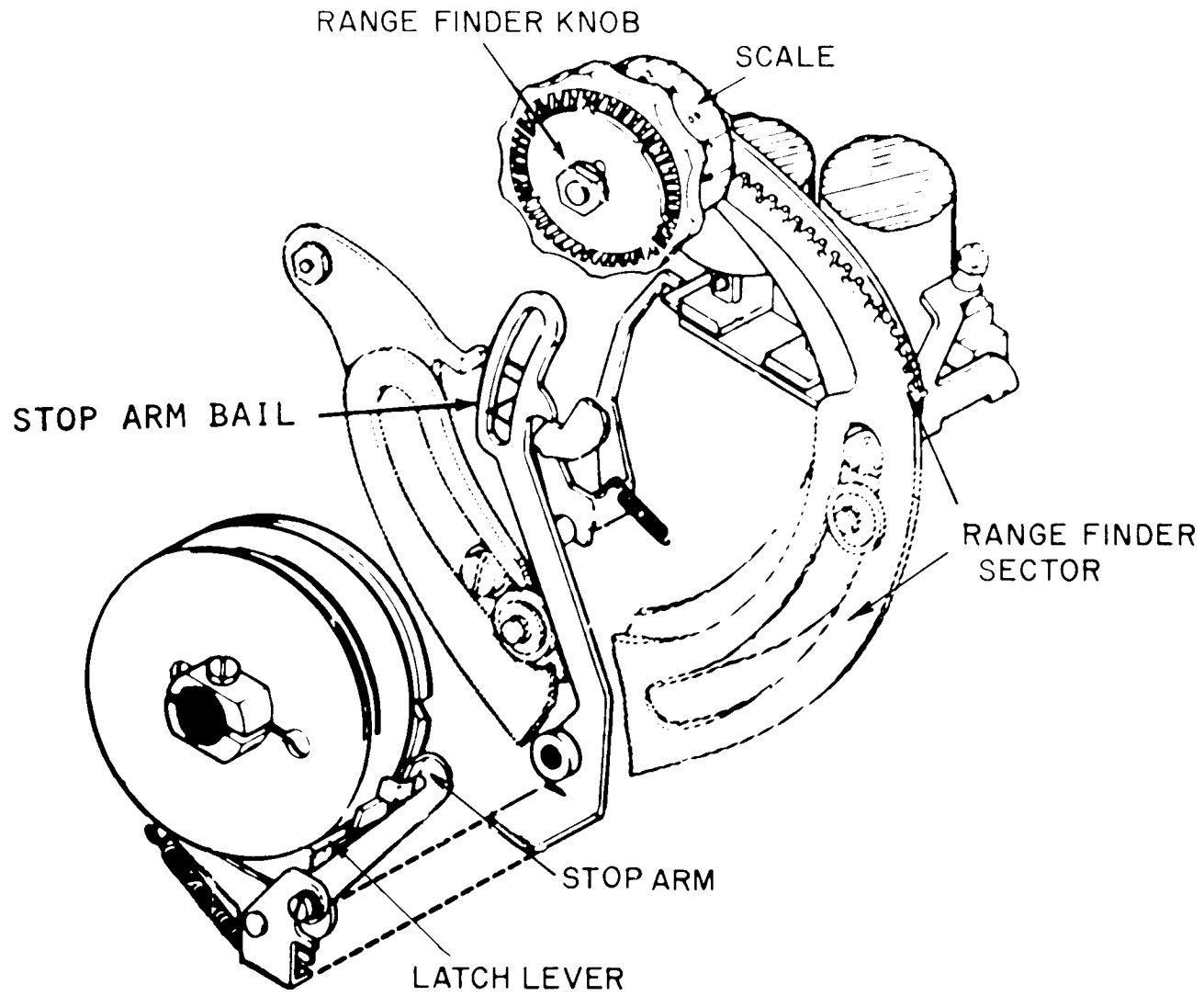

MOD 28 ASR/UGC-6K RANGE FINDER OPERATION (RIGHT VIEW)

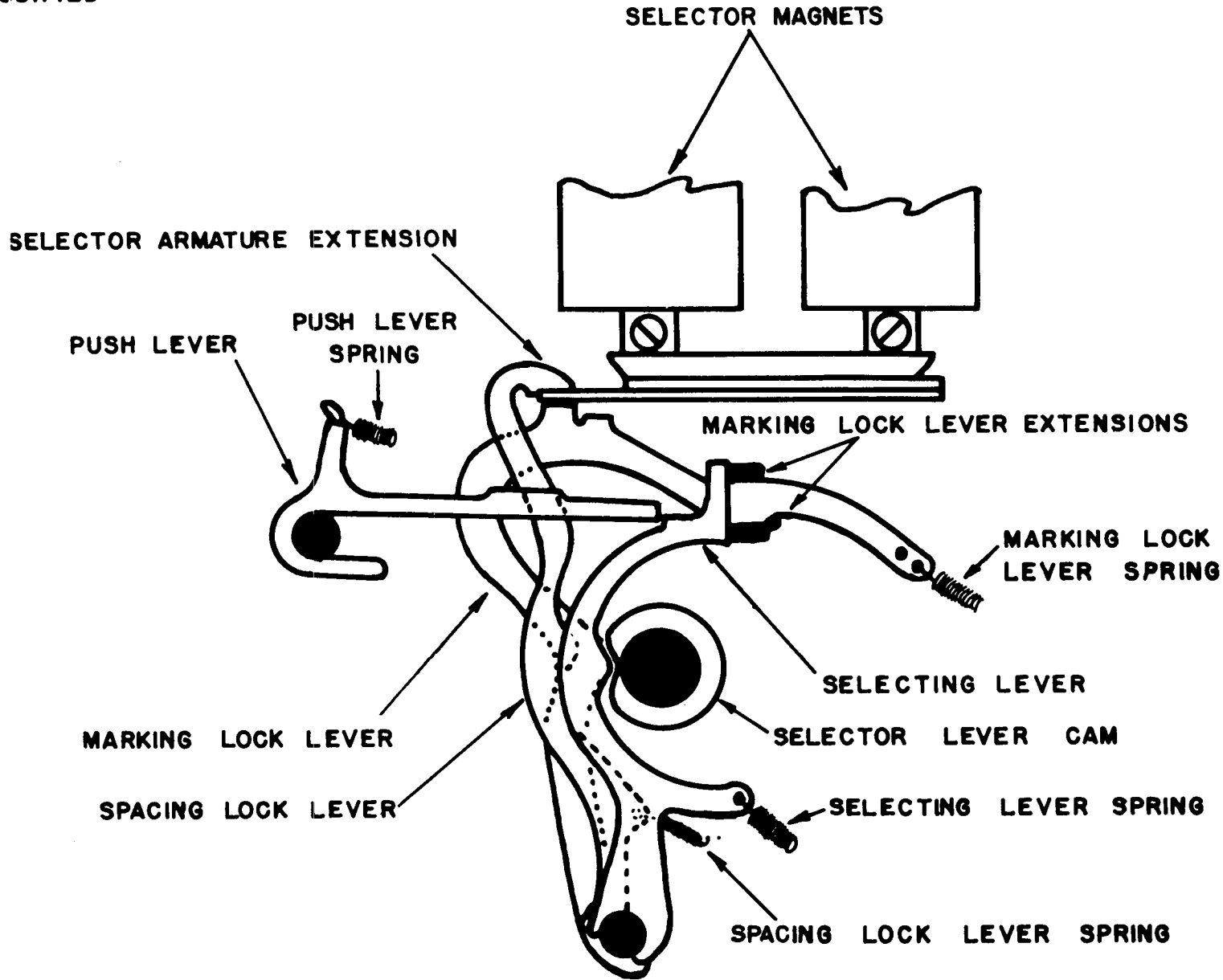

13

MOD 28 ASR-AN/UGC-6K SELECTING MECHANISM (RIGHT VIEW)

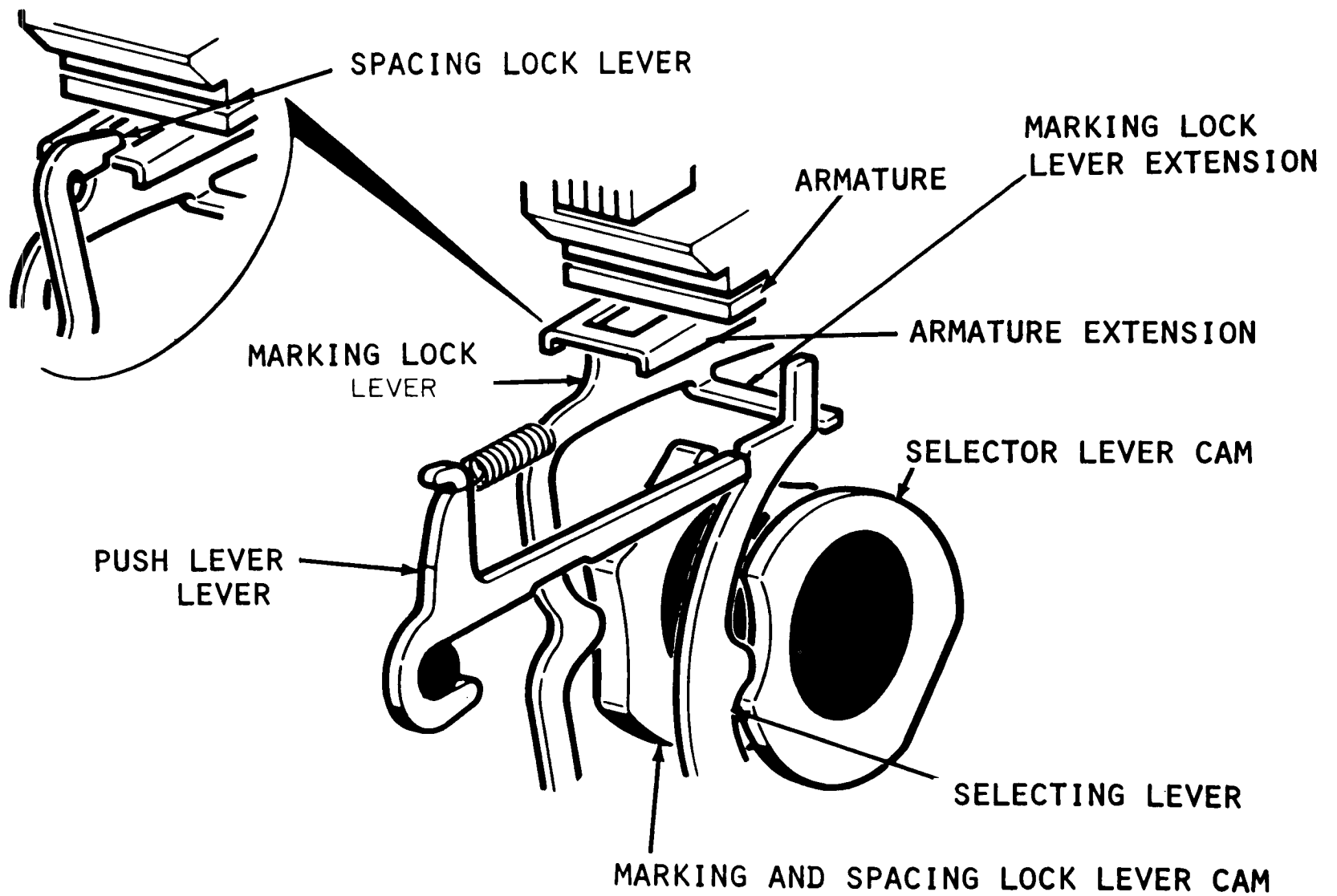

14

MOD 28 ASR -AN/UGC-6K SELECTION (MARKING) (RIGHT VIEW)

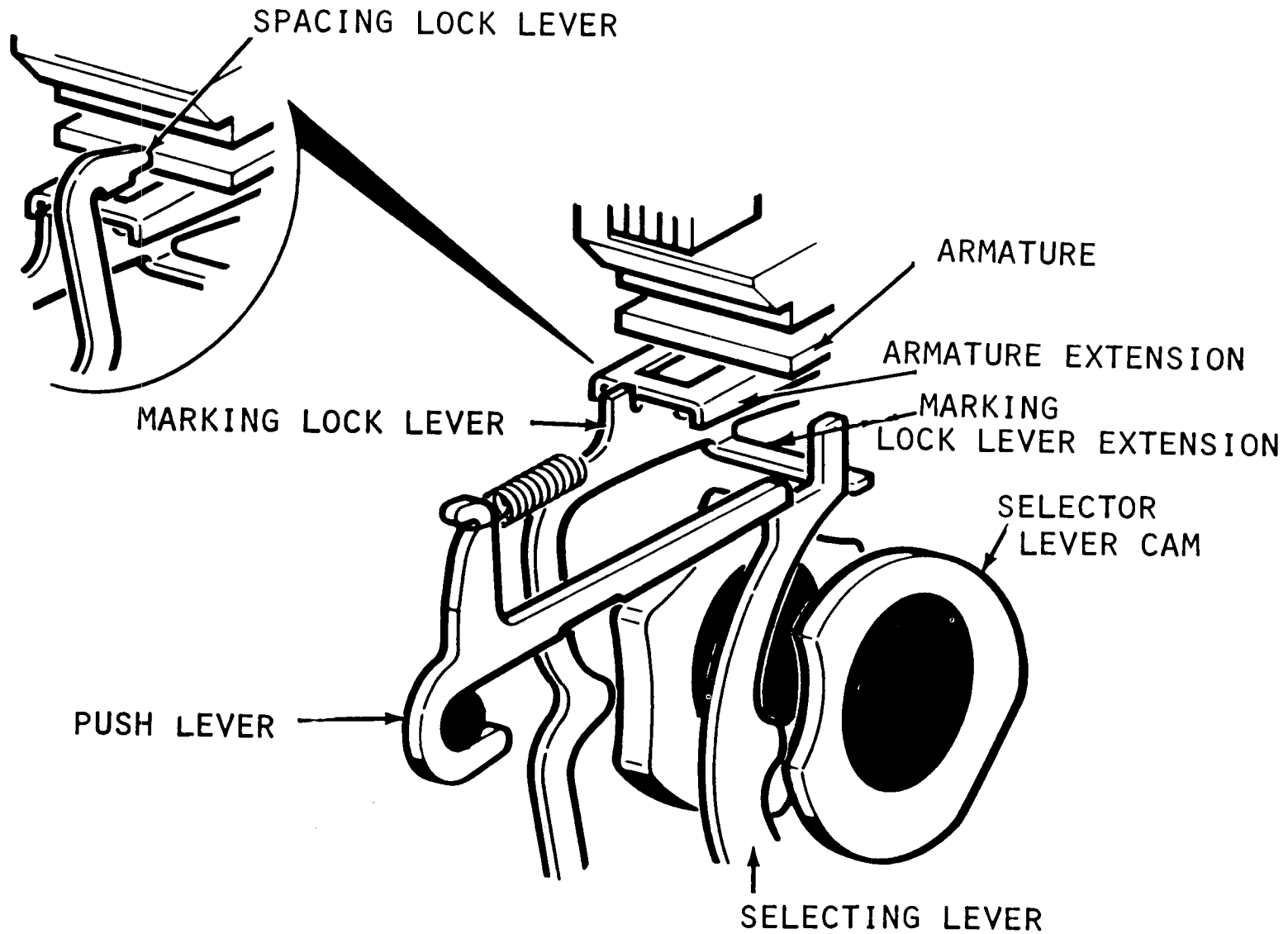

15

MOD 28 ASR-AN/UGC-6K SELECTION (SPACING, RIGHT VIEW)

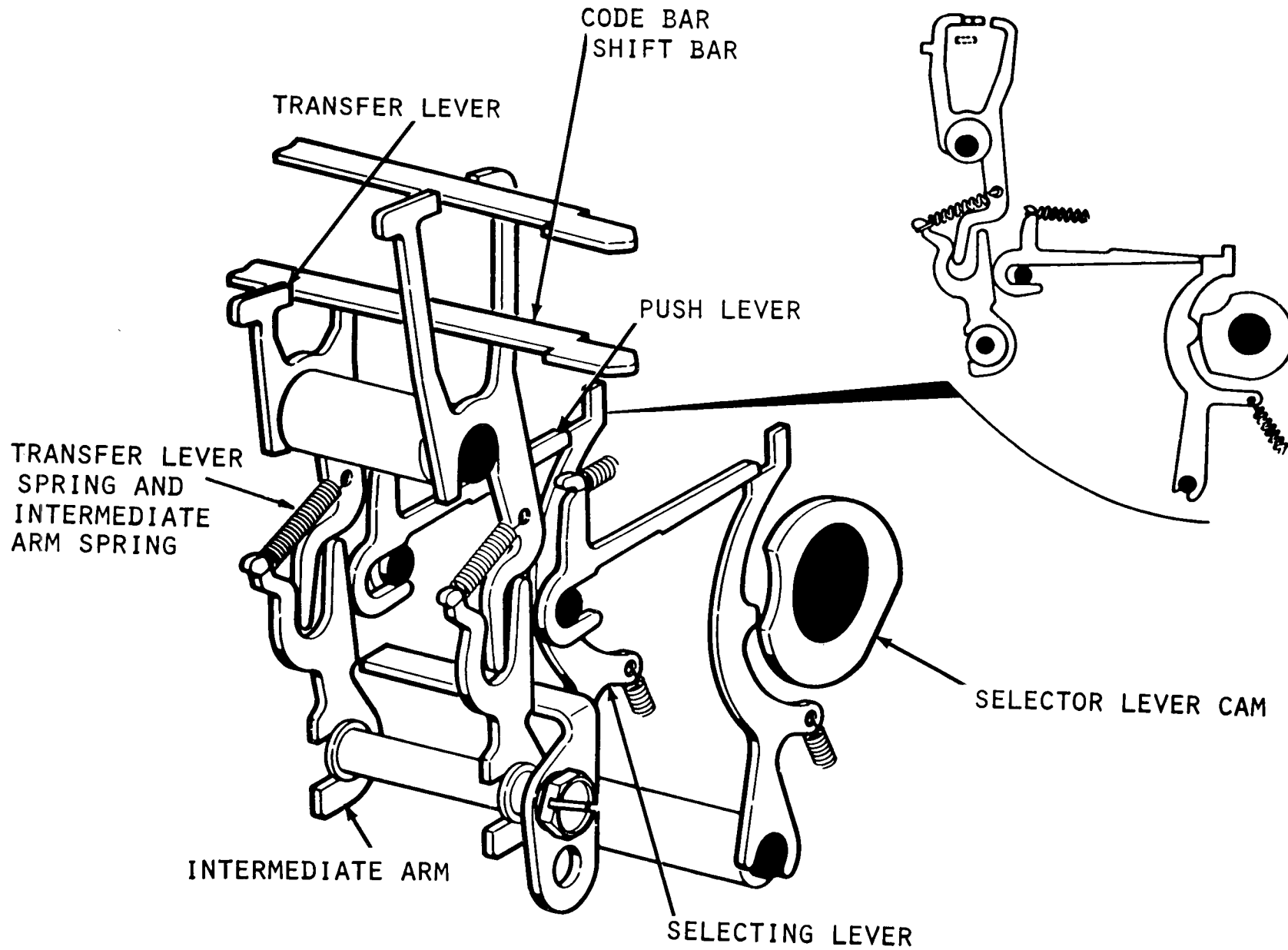

MOD 28 ASR-AN/UGC-6K TRANSFER MECHANISM (MARKING, RIGHT VIEW)

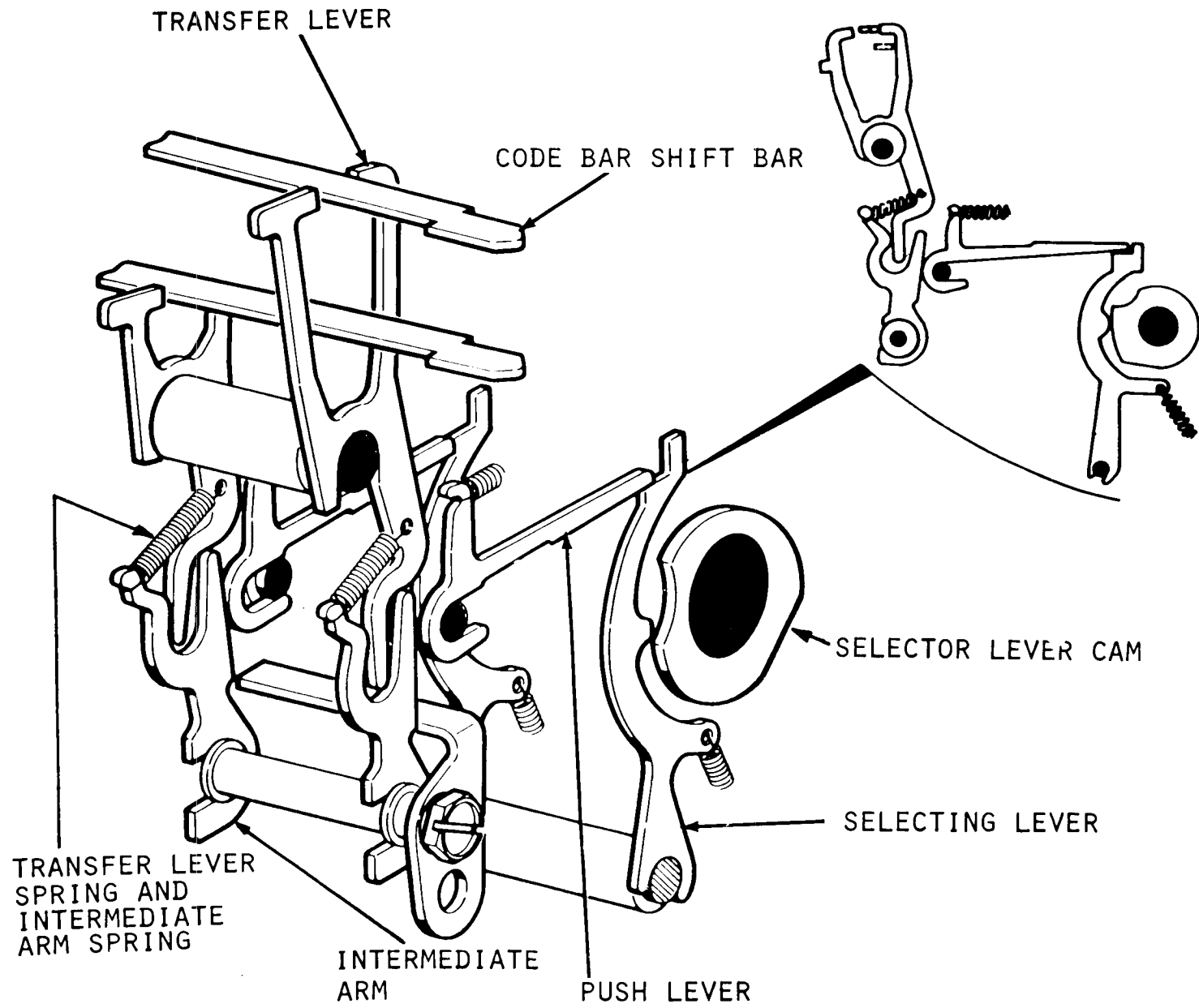

MOD 28 ASR-AN/UGC-6K TRANSFER MECHANISM (SPACING, RIGHT VIEW)

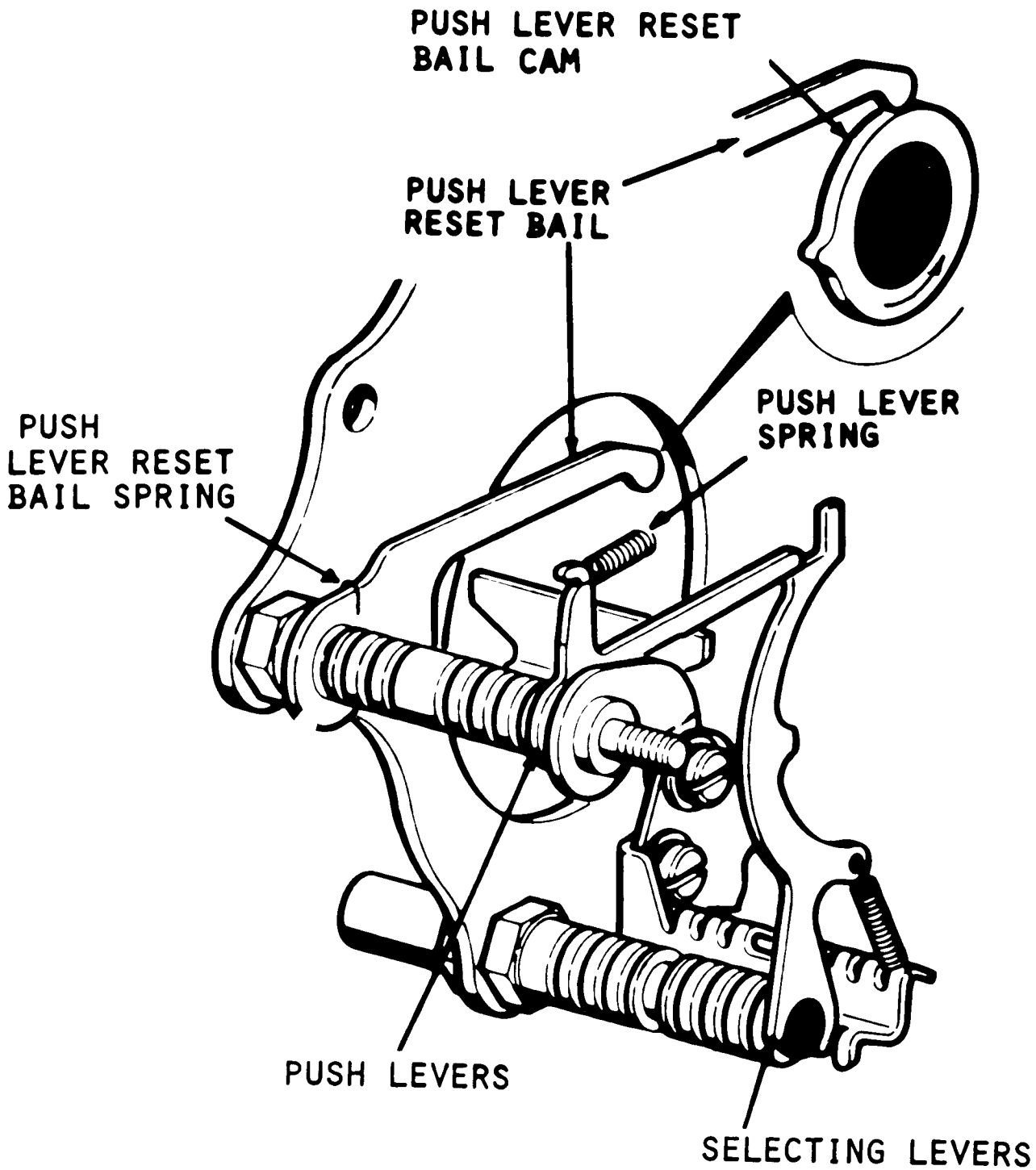

MOD 28 ASR-AN/UGC-6K PUSH LEVER RESET (RIGHT VIEW)

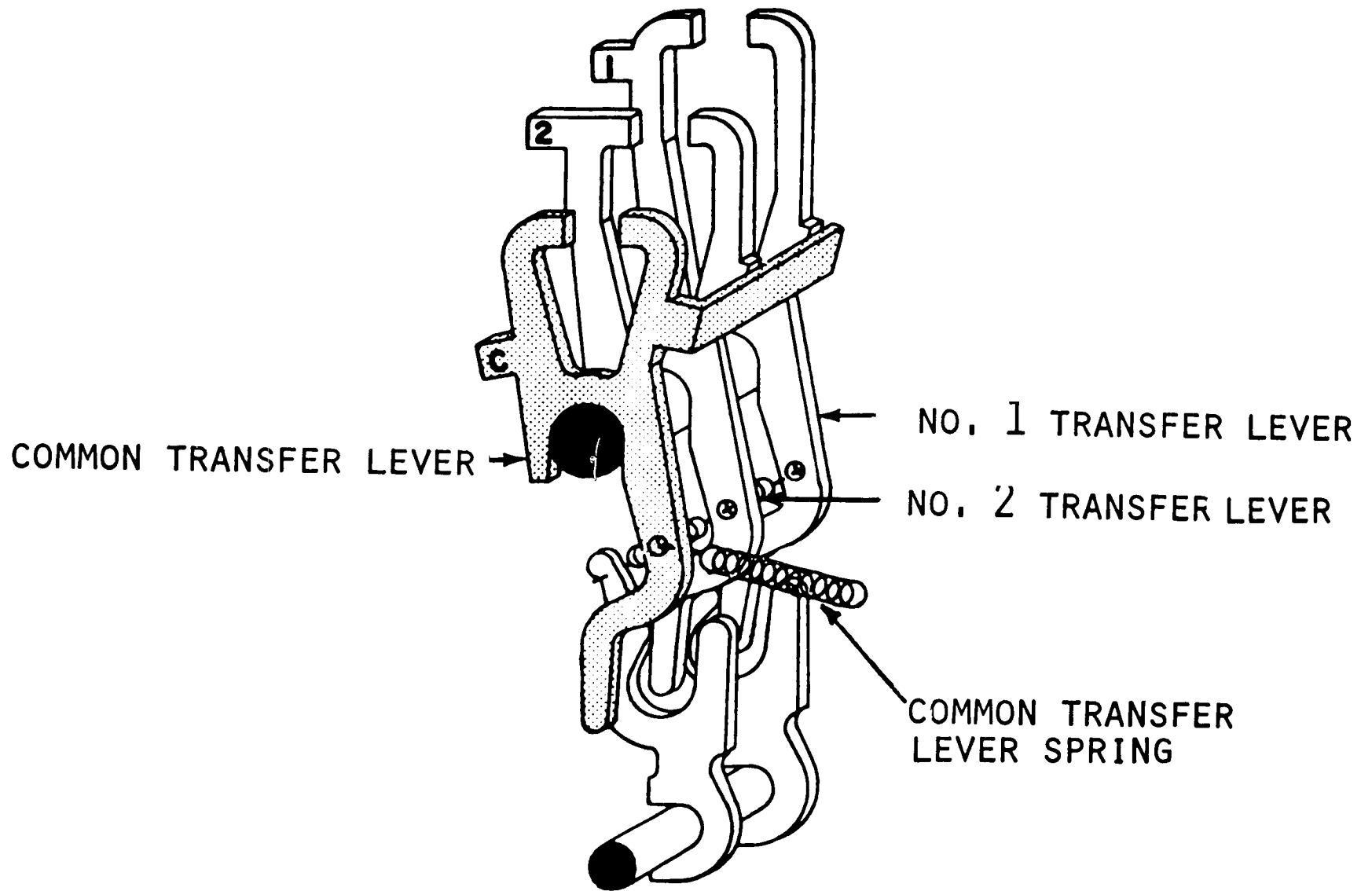

MOD 28 ASR-AN/UGC-6K COMMON TRANSFER LEVER (RIGHT VIEW)

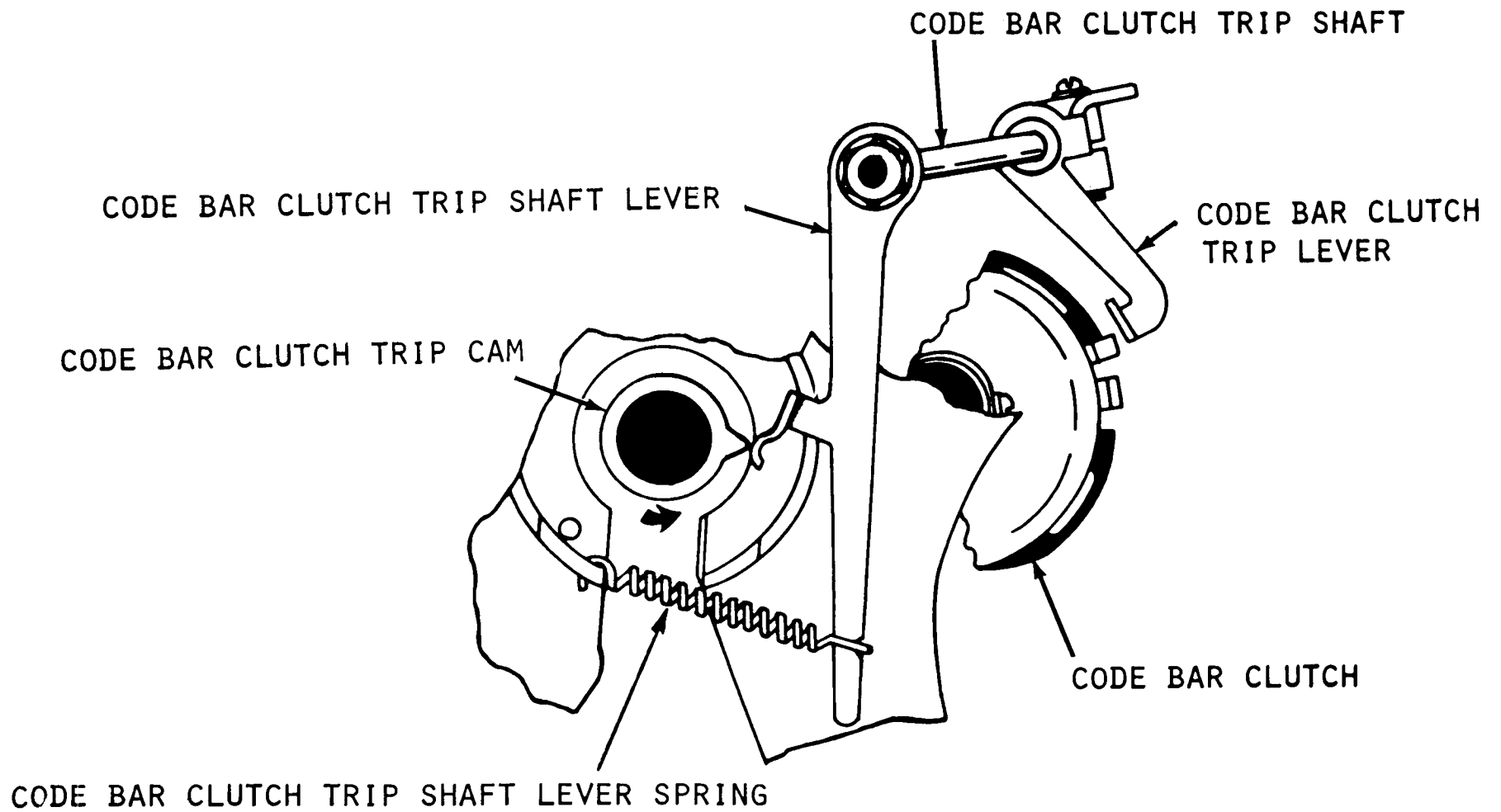

MOD28 MOD 28 ASR-AN/UGC-6K CODE BAR CLUTCH TRIP (RIGHT VIEW)

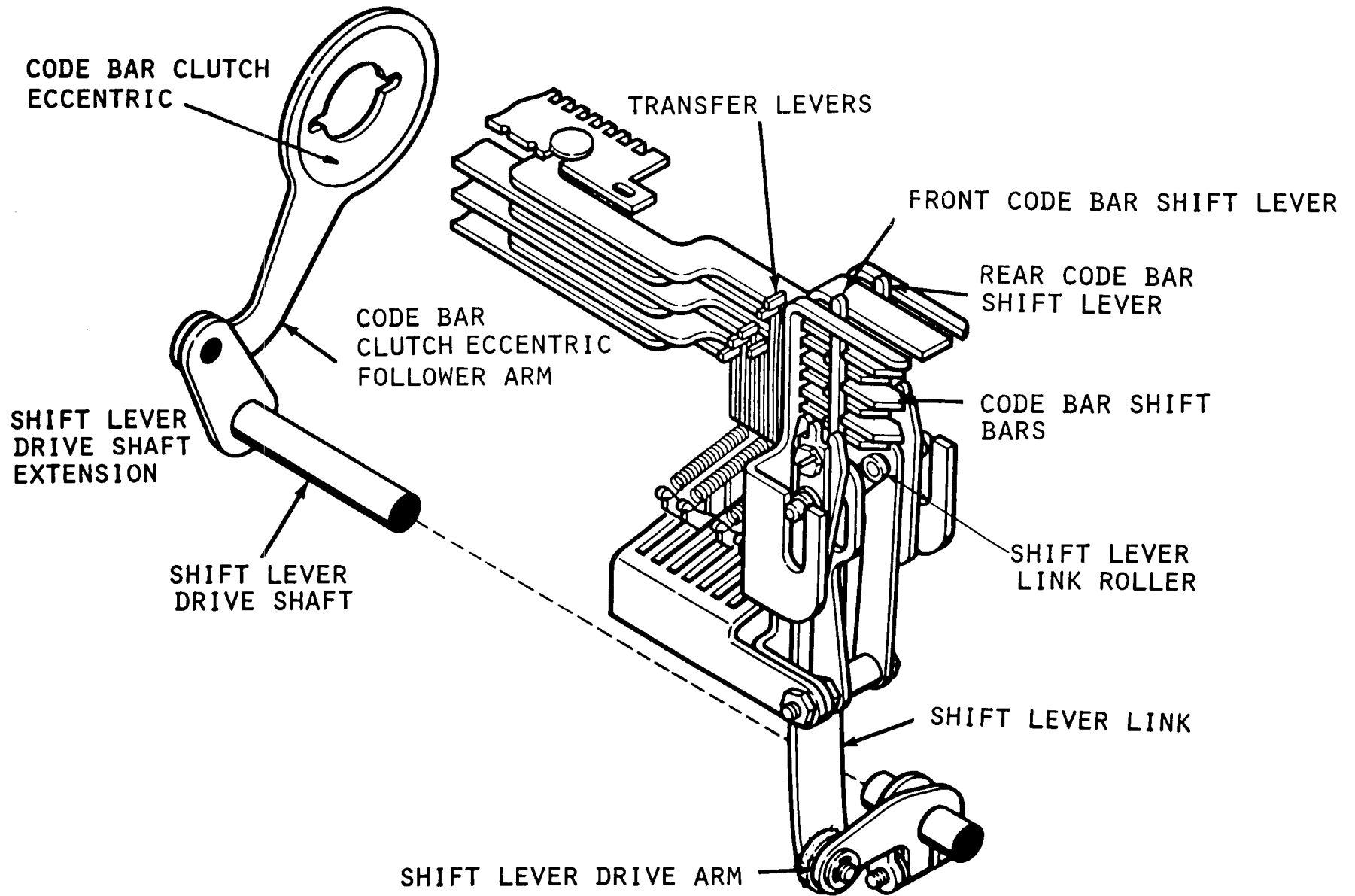

21

MOD 28 ASR-AN/UGC-6K CODE BAR SHIFT MECHANISM #1 (RIGHT VIEW)

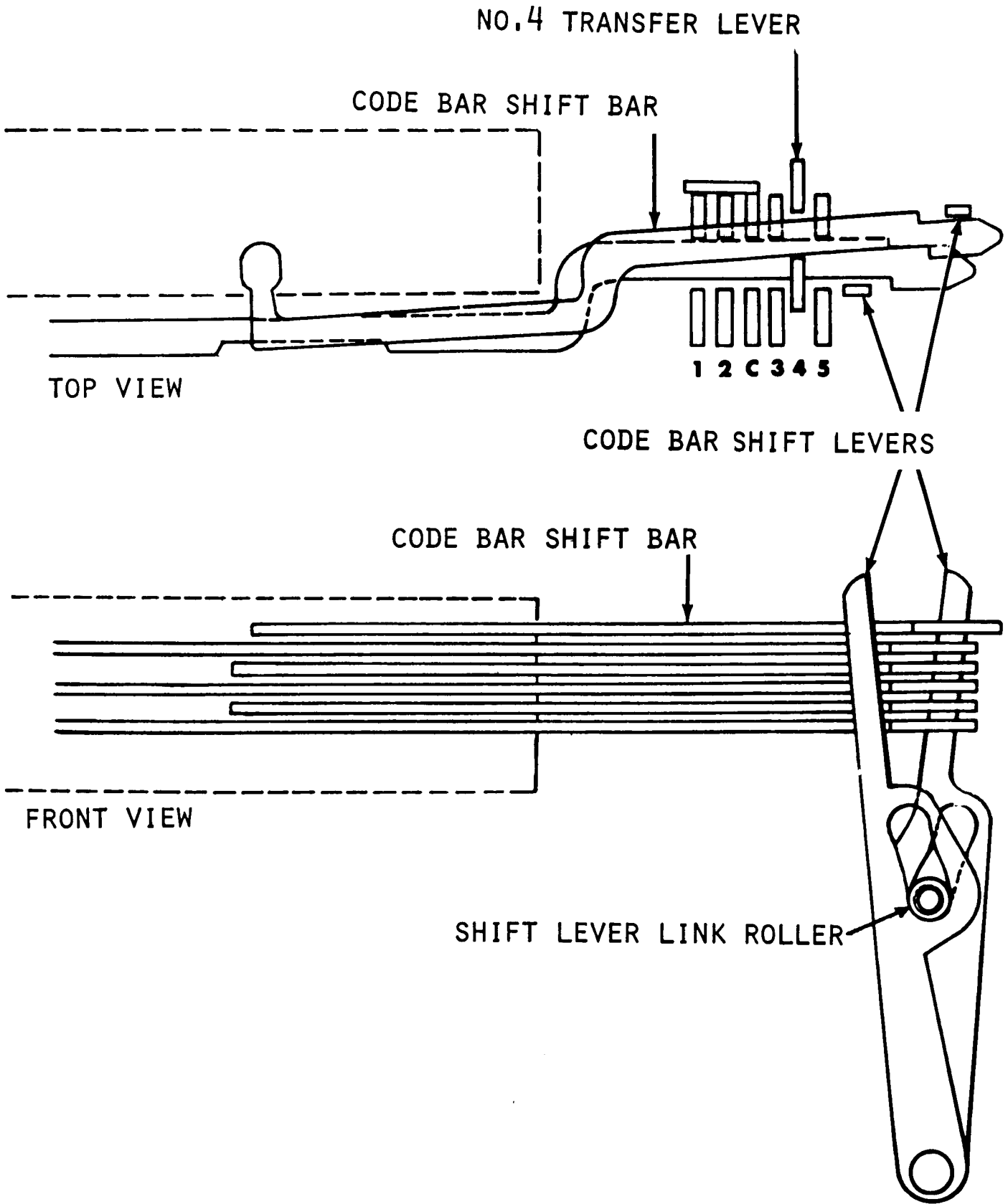

MOD 28 ASR-AN/UGC-6K CODE BAR SHIFT MECHANISM #2

23

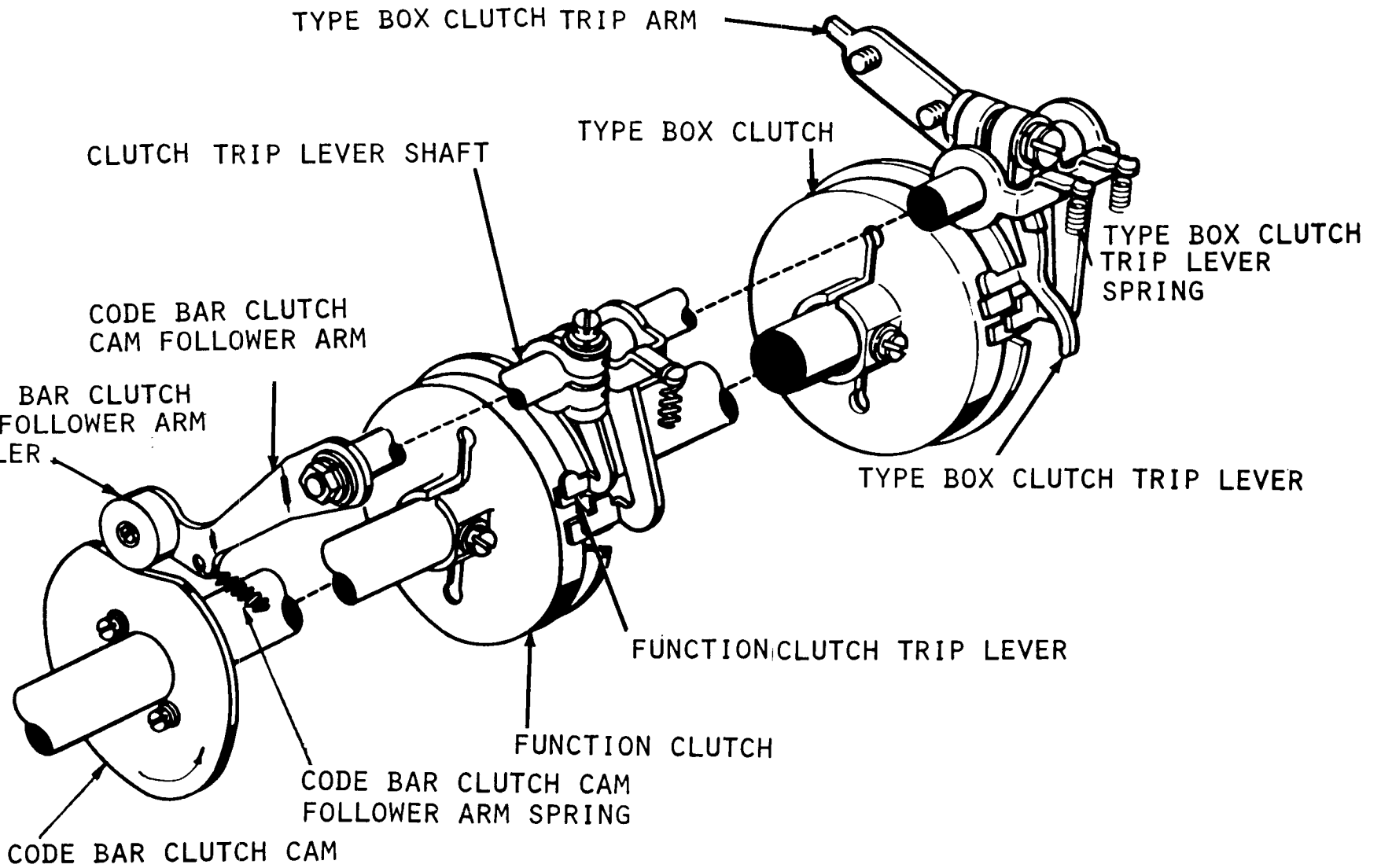

MOD 28 ASR-AN/UGC-6K CLUTCH TRIP SHAFT (RIGHT REAR VIEW)

LETTERS (HALF)

LEFT (SIDE)

	4 8 5 MARKING	4 5 MARKING	4 5 SPACING	4 8 5 MARKING
TOP ROW	M	N	H	SPACE
	--345	--34-	--3-5	--3--
2ND ROW	X	F	Y	S
	1-345	1-34-	1-3-5	1-3--
3RD ROW	V	C	P	I
	-2345	-234-	-23-5	-23--
BOTTOM ROW	LETTERS	K	Q	U
	12345	1234-	123-5	123--
	3 MARKING			
	4TH ROW	3RD ROW	2ND ROW	1ST ROW

RIGHT (SIDE)

	4 8 5 SPACING	4 5 MARKING	4 5 SPACING	4 8 5 MARKING
	BLANK	T	C. R.	O
	---	---	---	---
	E	Z	D	B
	1---	1---	1---	1---
	L F	L	R	G
	-2---	-2---	-2---	-2---
	A	W	J	FIGURES
	12---	12---	12---	12---
	3 SPACING			
	1ST ROW	2ND ROW	3RD ROW	4TH ROW

FIGURES (HALF)

LEFT (SIDE)

	4 8 5 MARKING	4 5 SPACING	4 5 MARKING	4 8 5 SPACING
	.	,		SPACE
	--345	--34-	--3-5	--3--
	/	!	6	BELL
	1-345	1-34-	1-3-5	1-3--
	;	:	ø	8
	-2345	-234-	-23-5	-23--
	LETTERS	(1	7
	12345	1234-	123-5	123--
	3 MARKING			
	4TH ROW	3RD ROW	2ND ROW	1ST ROW

RIGHT (SIDE)

	4 8 5 SPACING	4 5 MARKING	4 5 SPACING	4 8 5 MARKING
	BLANK	5	C. R.	9
	---	---	---	---
	3	"	\$?
	1---	1---	1---	1---
	L. F.)	4	&
	-2---	-2---	-2---	-2---
	-	2	∇	FIGURES
	12---	12---	12---	12---
	3 SPACING			
	1ST ROW	2ND ROW	3RD ROW	4TH ROW

MOD 28 ASR-AN/UGC-6K CONFIGURATION OF THE TYPE BOX

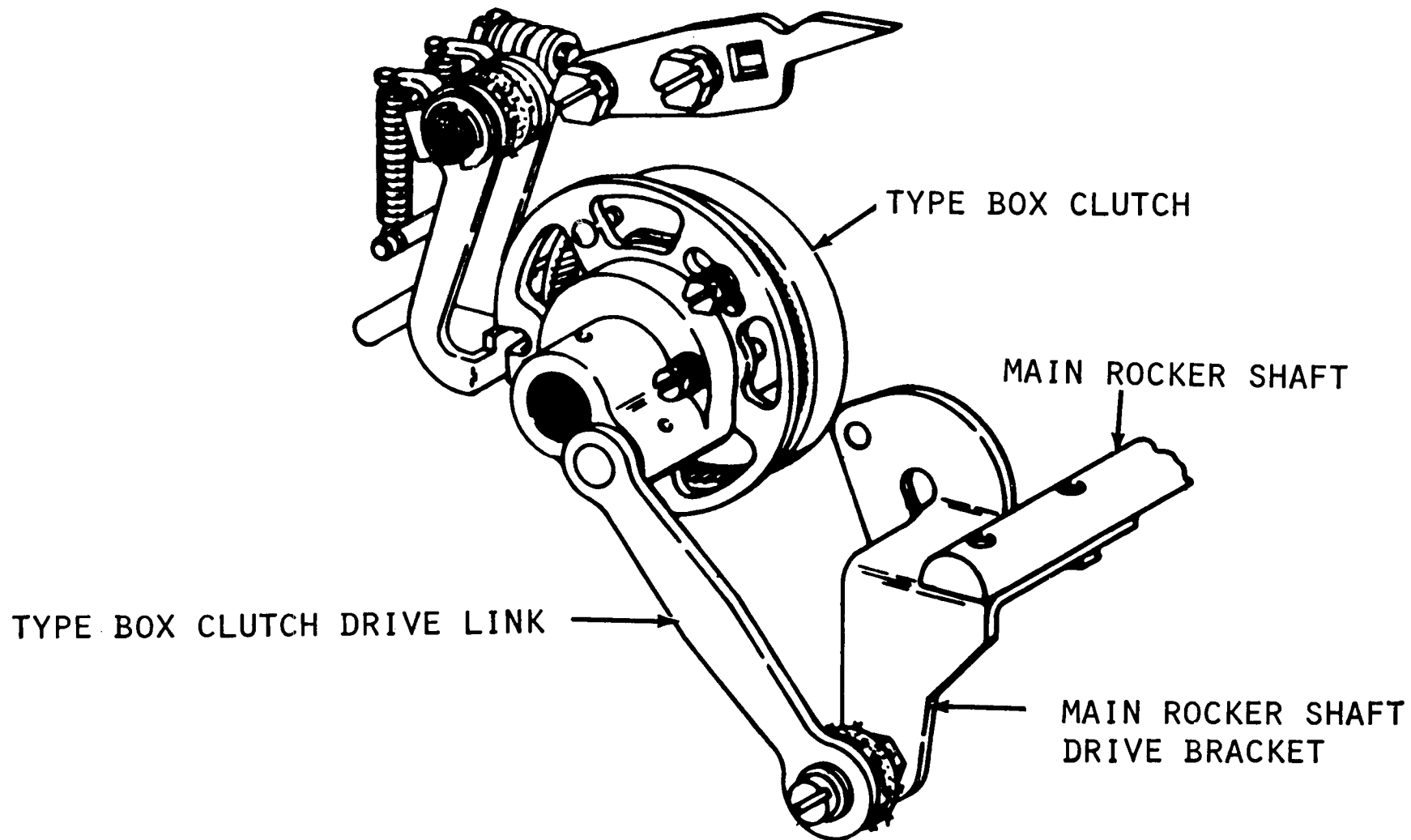

MOD 28 ASR-AN/UGC-6K TYPE BOX CLUTCH (LEFT VIEW)

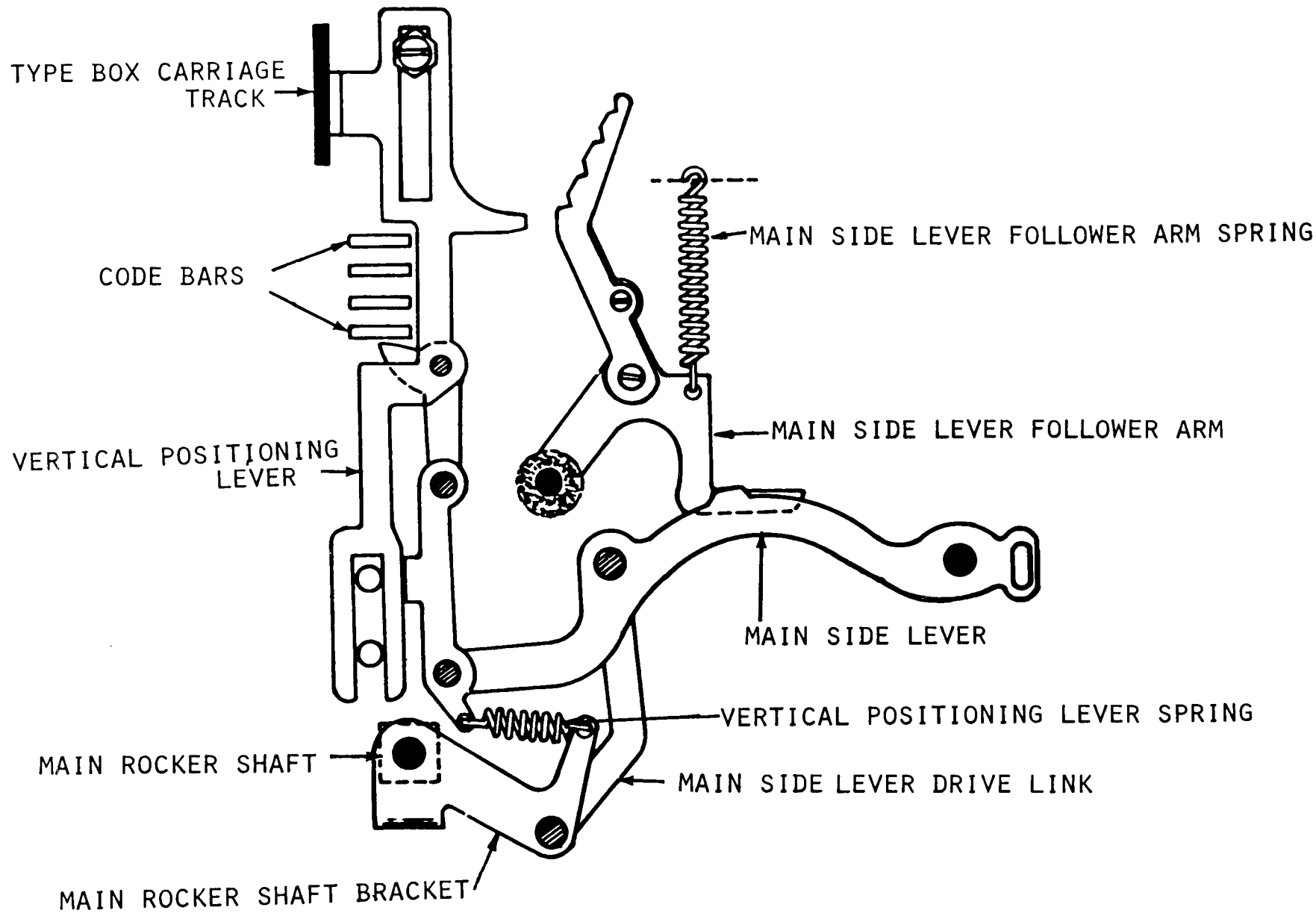

MOD 28 ASR-AN/UGC-6K VERTICAL POSITIONING (RIGHT VIEW)

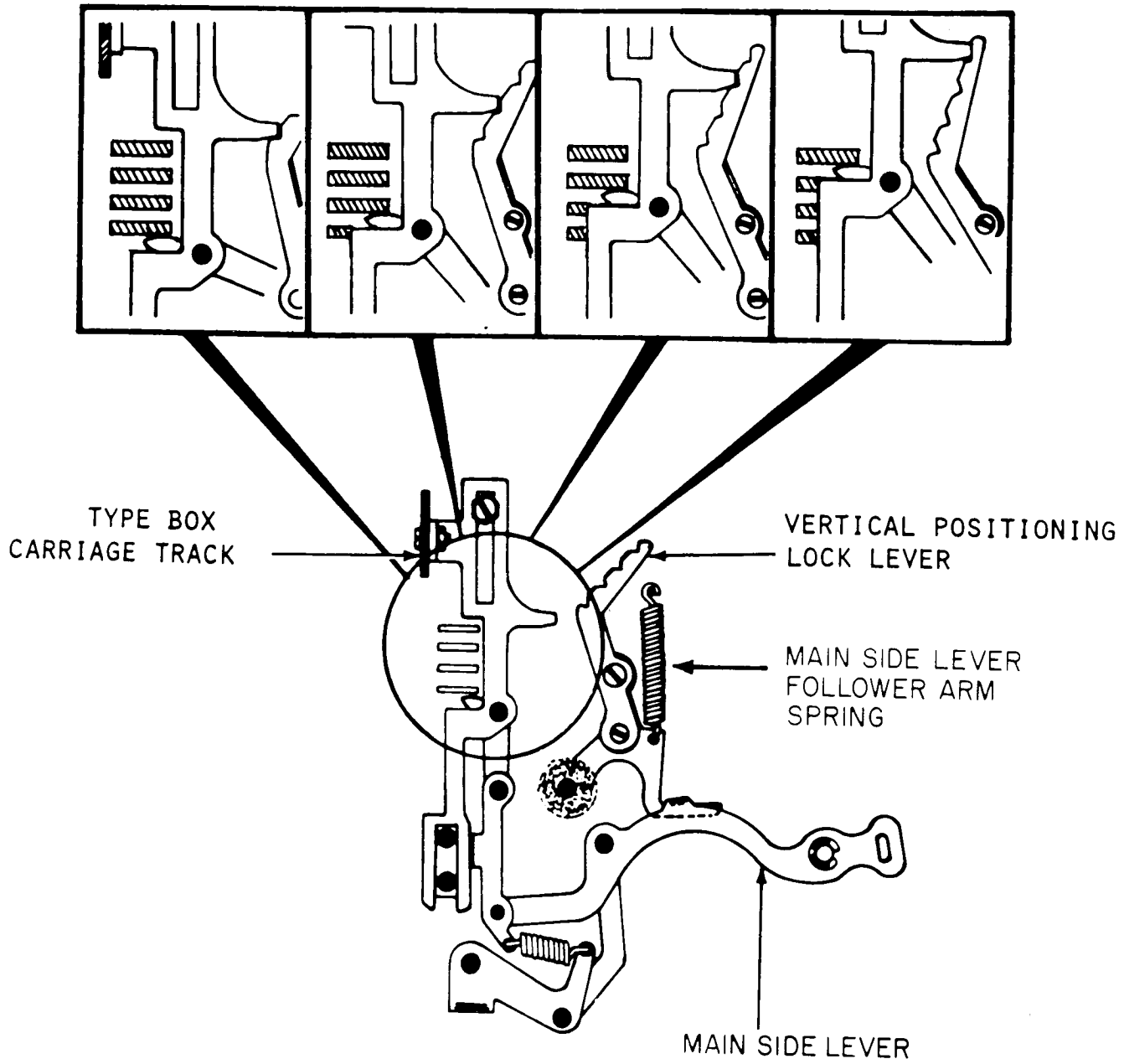

MOD 28 ASR-AN/UGC-6K VERTICAL POSITIONING LOCK LEVERS (RIGHT VIEW)

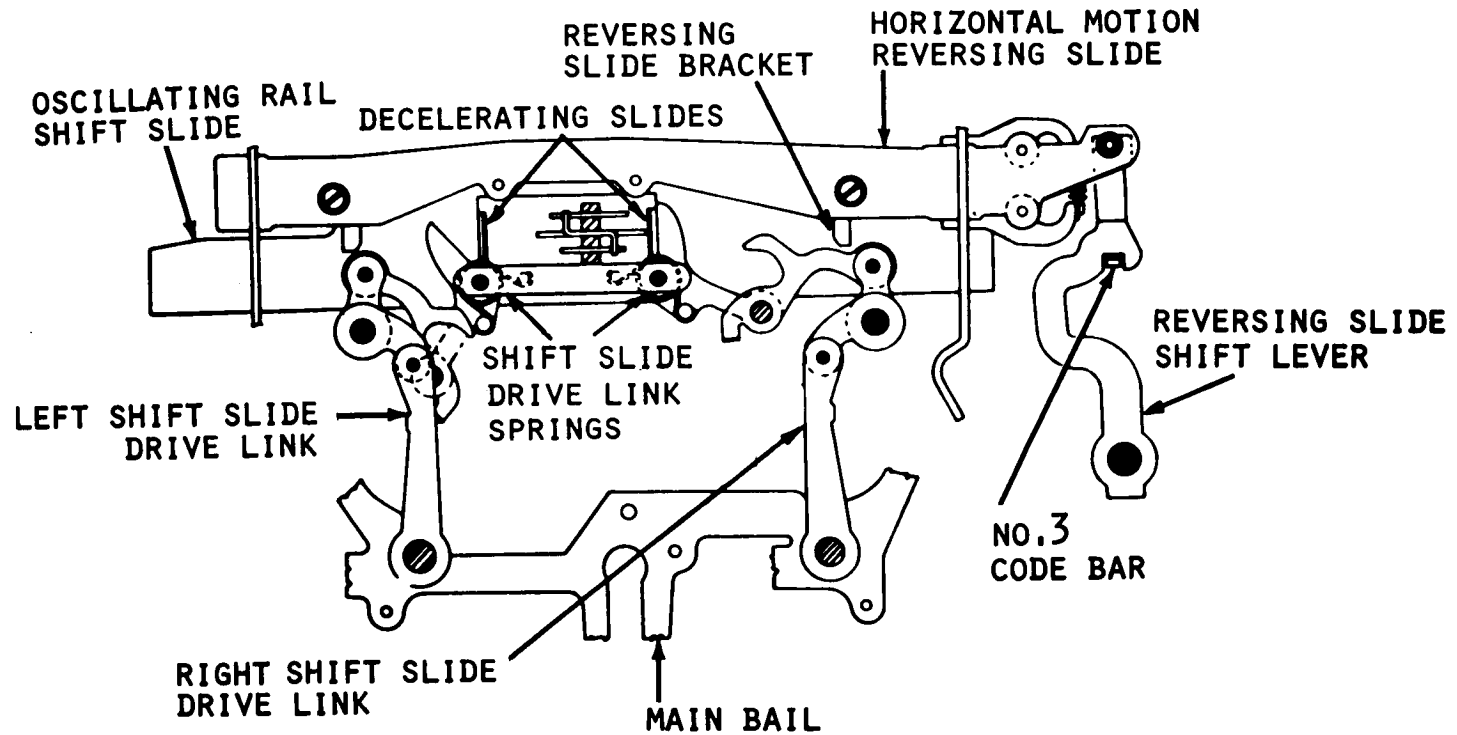
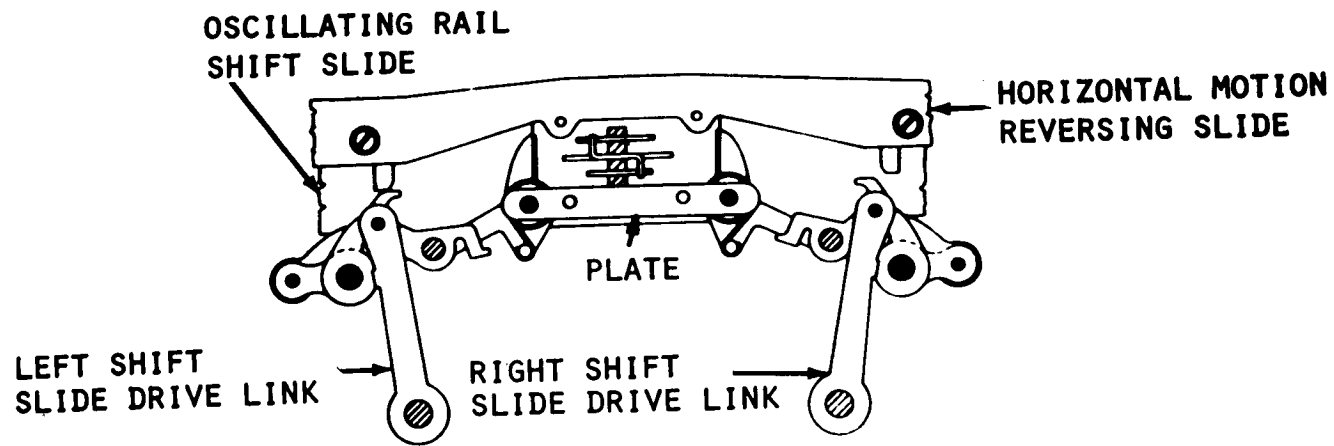

MOD 28 ASR-AN/UGC-6K REVERSING SLIDE

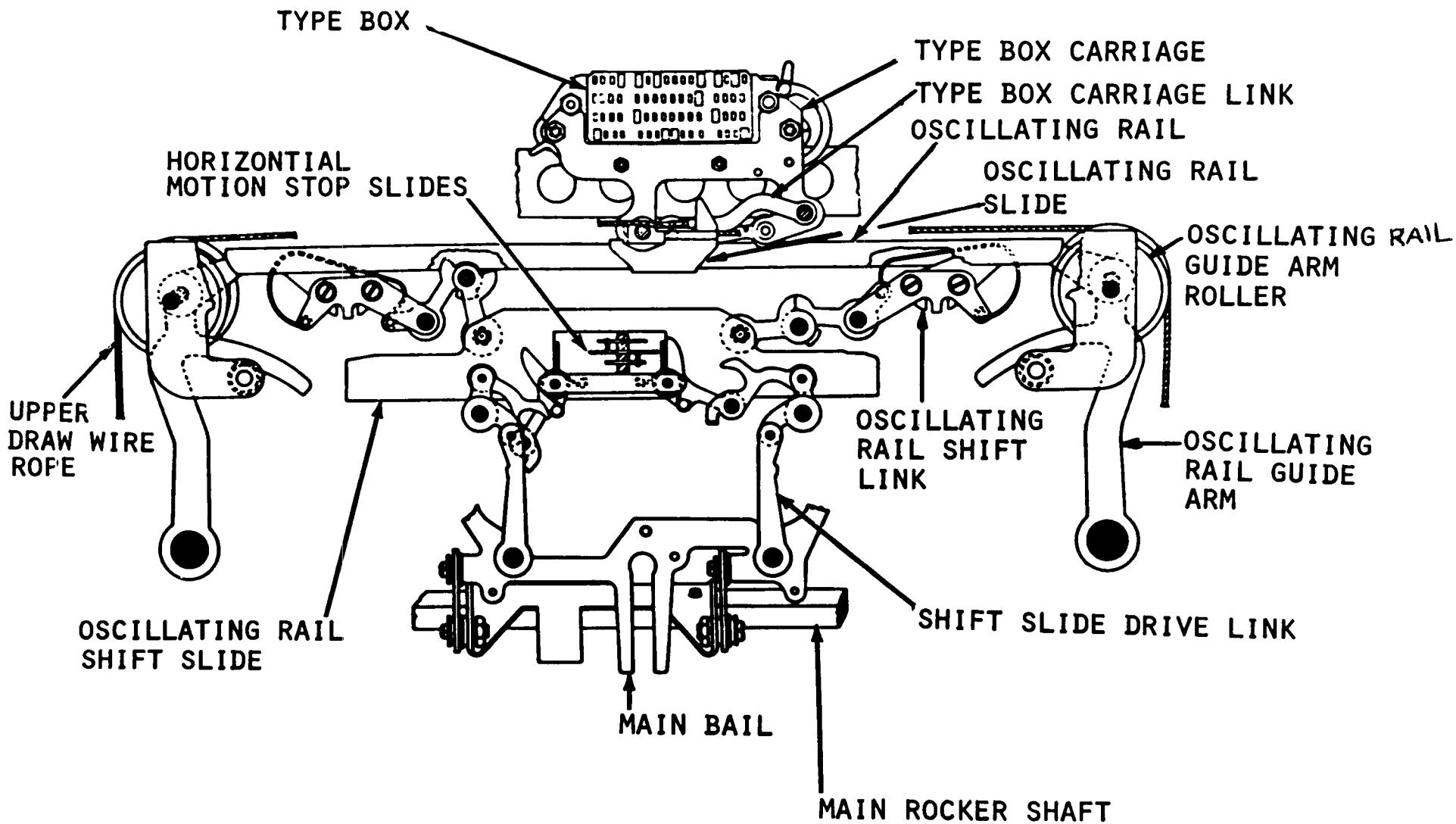

29

MOD 28 ASR-AN/UGC-6K HORIZONTAL POSITIONING

SHIFT SLIDE DRIVE LINK ASSEMBLIES

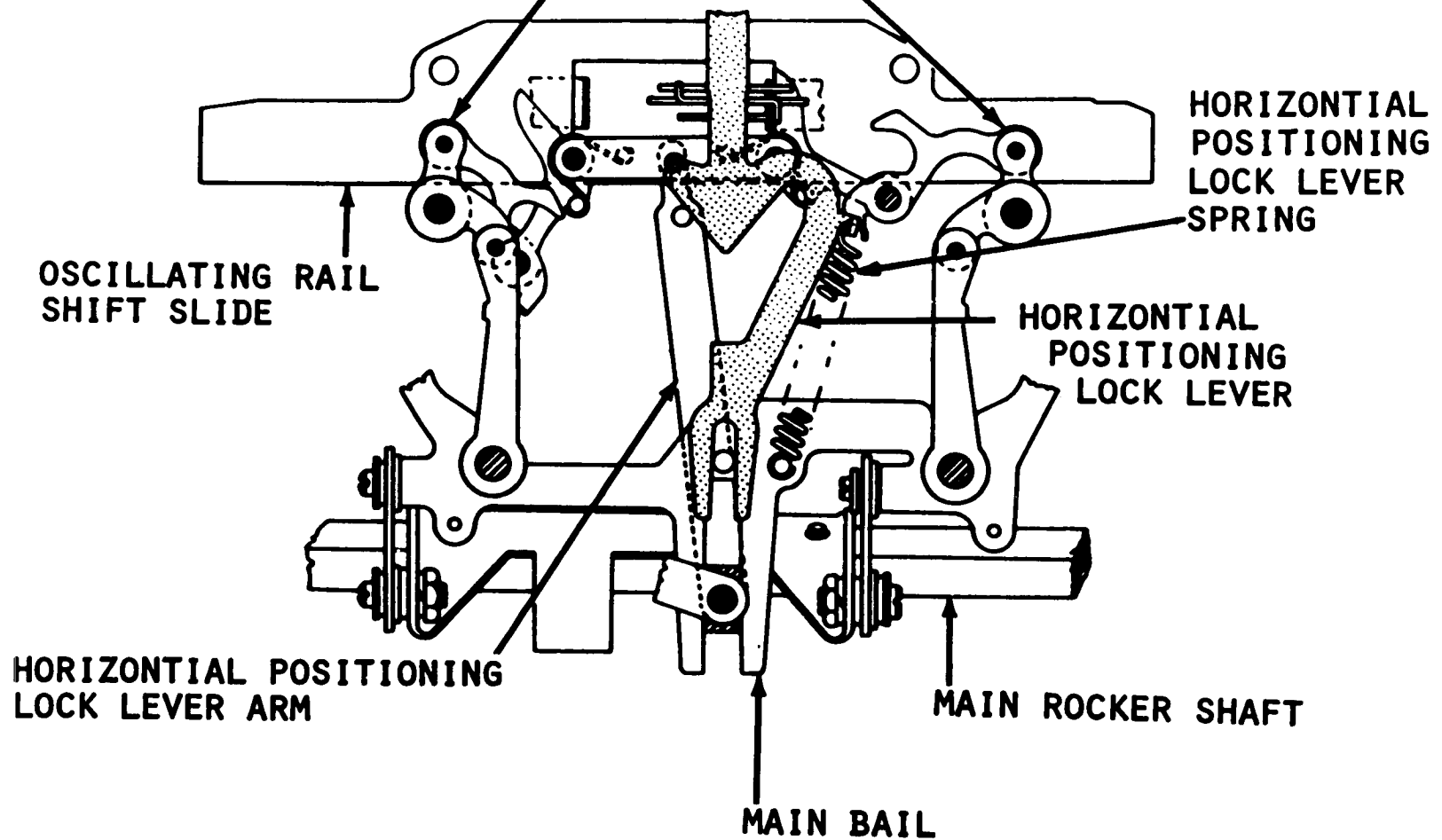

30

MOD 28 ASR-AN/UGC-6K HORIZONTAL POSITIONING LOCK LEVER

NO. 4 HORIZONTAL MOTION STOP
SLIDE
(UPPER)

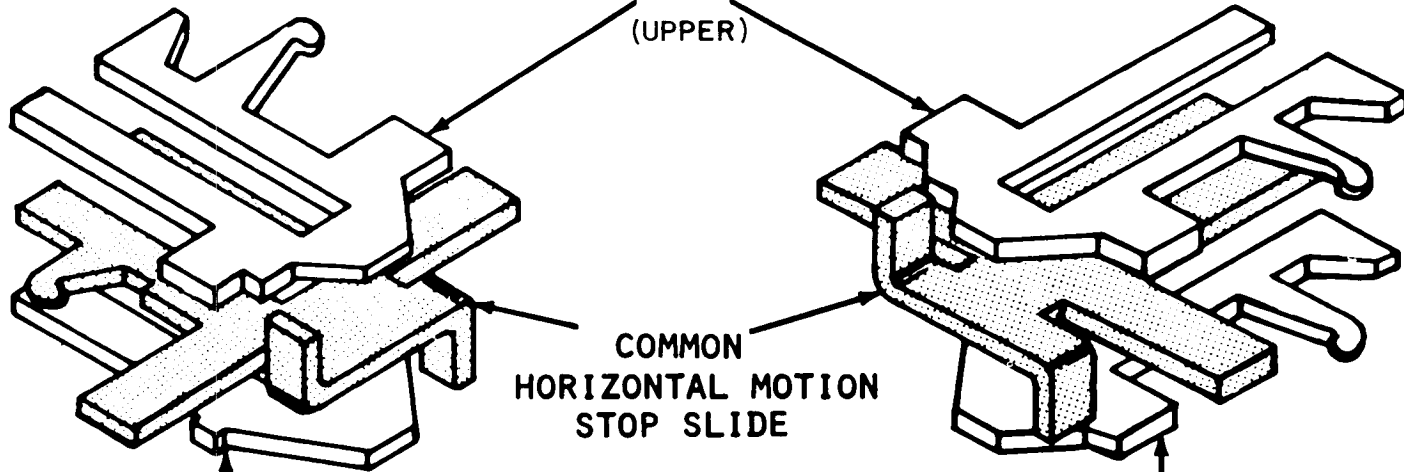

NO. 5 HORIZONTAL
MOTION STOP SLIDE
(LOWER)

COMMON
HORIZONTAL MOTION
STOP SLIDE

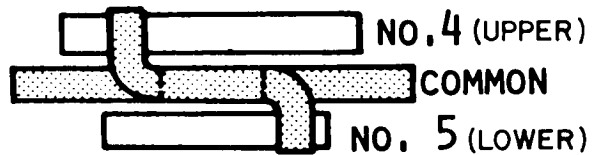

NO. 5 HORIZONTAL
MOTION STOP SLIDE
(LOWER)

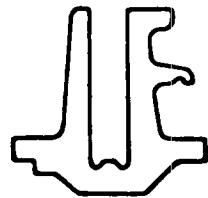

NO. 4 STOP SLIDE
(UPPER)

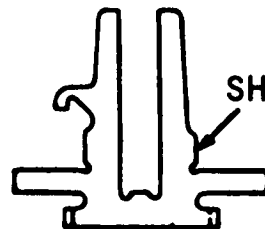

SHANK OF COMMON

COMMON STOP SLIDE

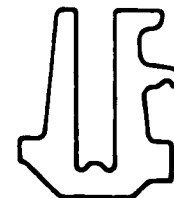

NO. 5 STOP SLIDE
(LOWER)

MOD 28 ASR-AN/UGC-6K HORIZONTAL MOTION STOP SLIDES

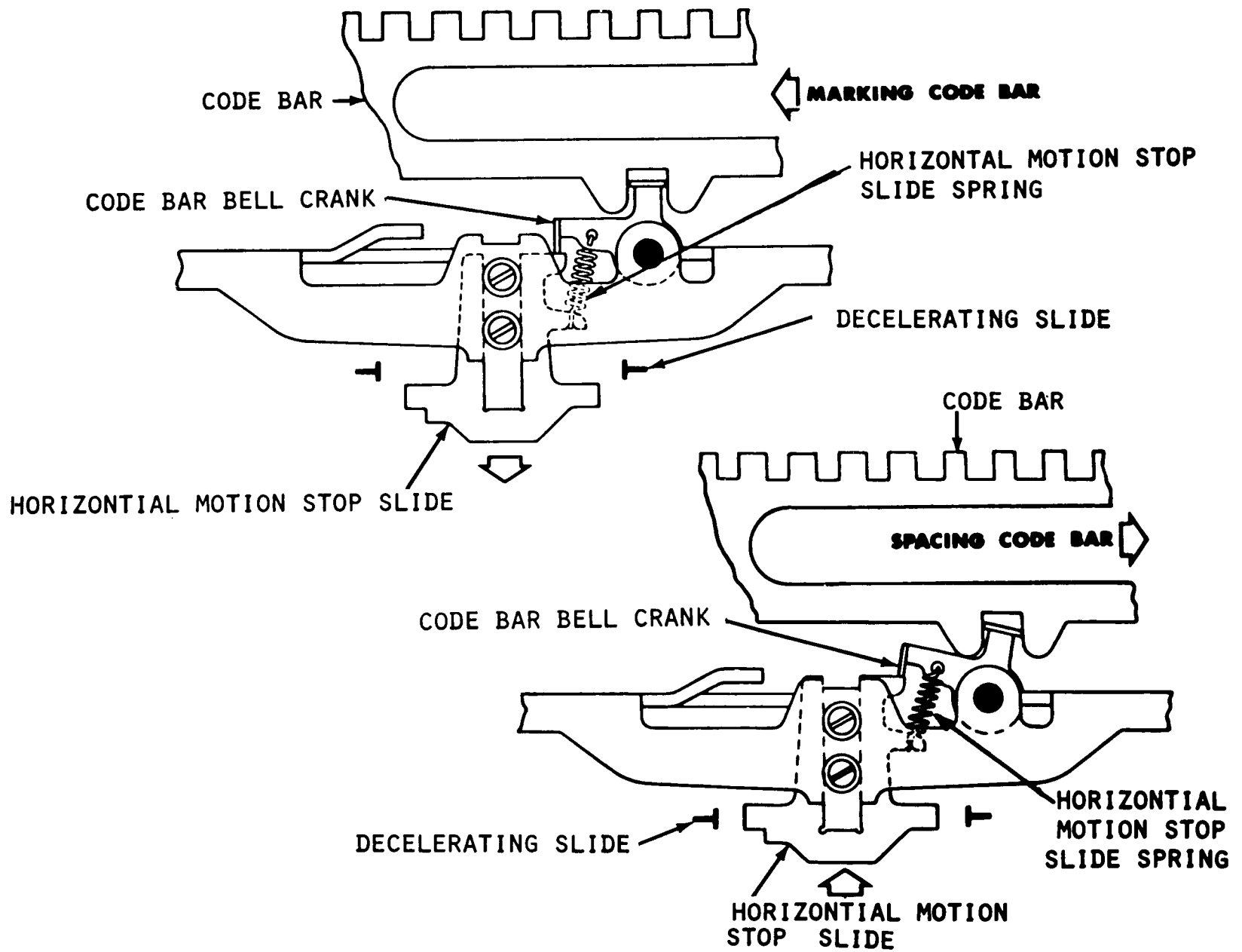

32

MOD 28 ASR-AN/UGC-6K HORIZONTAL MOTION STOP SLIDE POSITIONING (TOP VIEW)

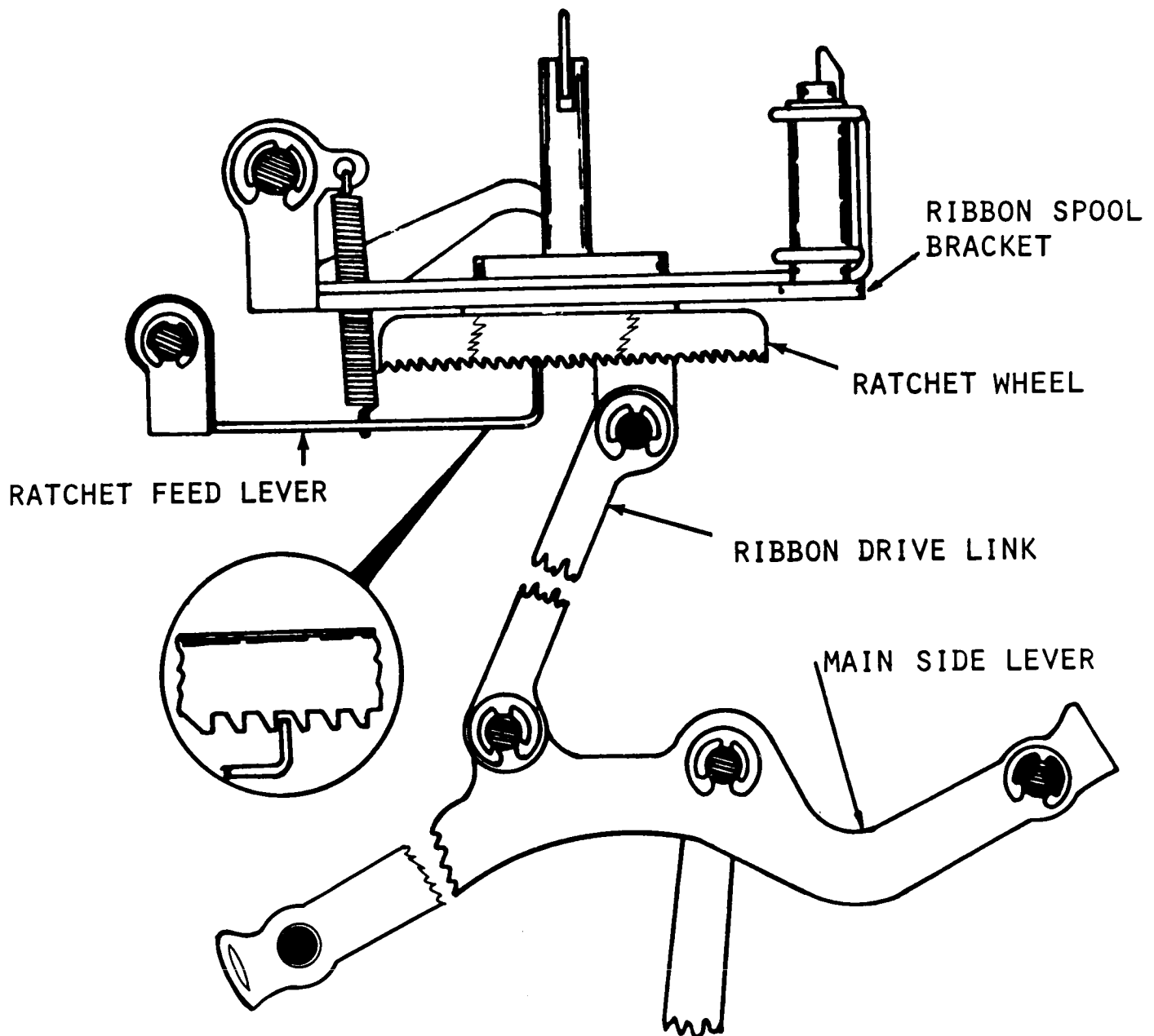

MOD 28 ASR-AN/UGC-6K RIBBON OSCILLATION (LEFT VIEW)

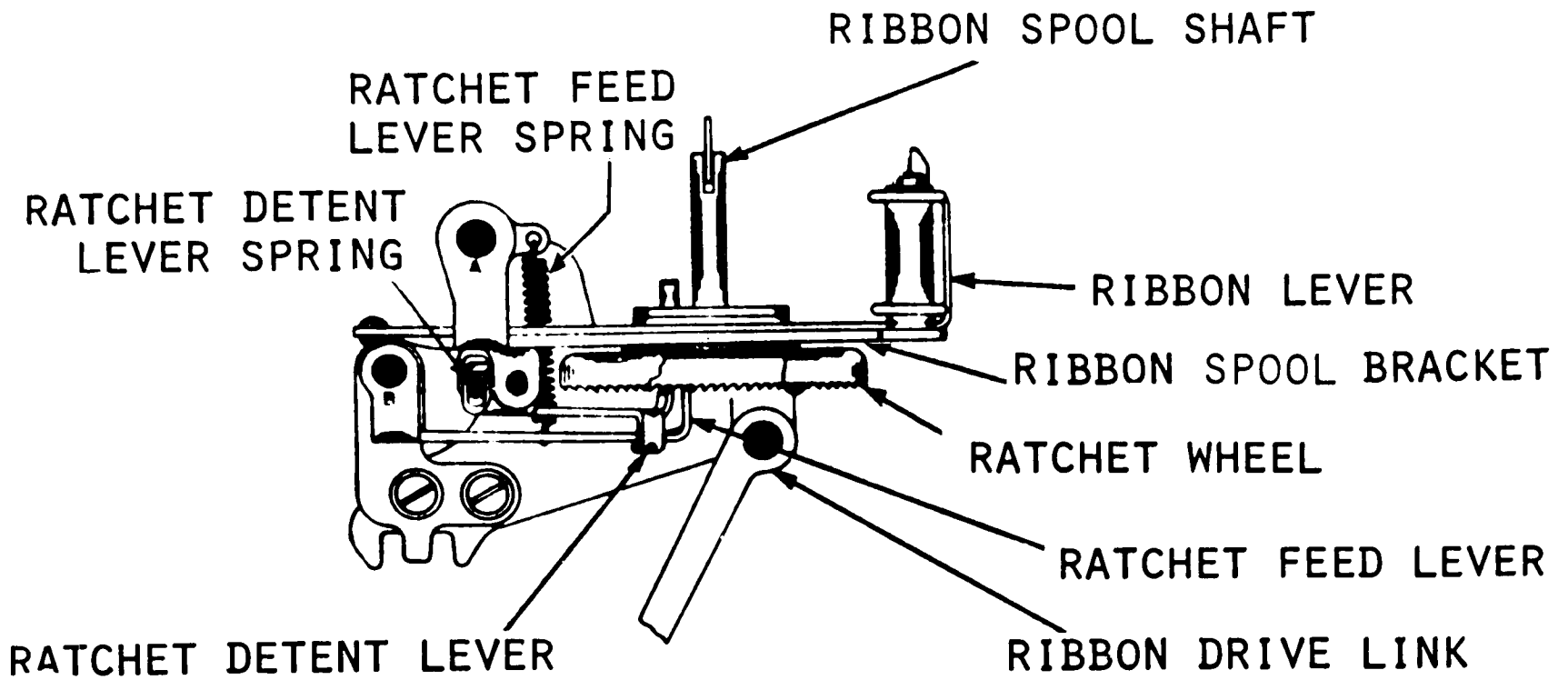

MOD 28 ASR - AN/UGC-6K- RIBBON FEED (LEFT VIEW)

2-3-7D

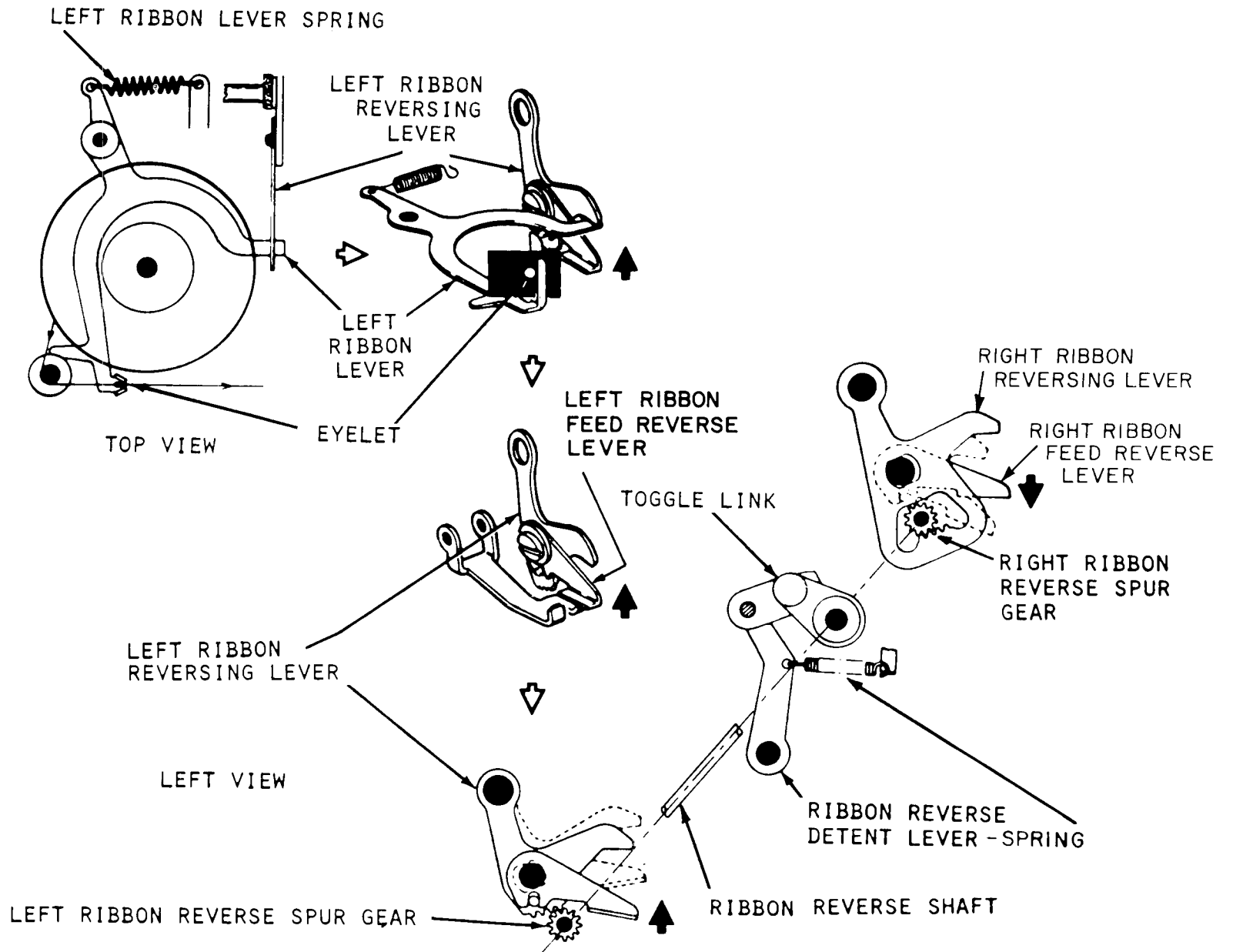

MOD 28 ASR-AN/UGC -6K RIBBON REVERSE

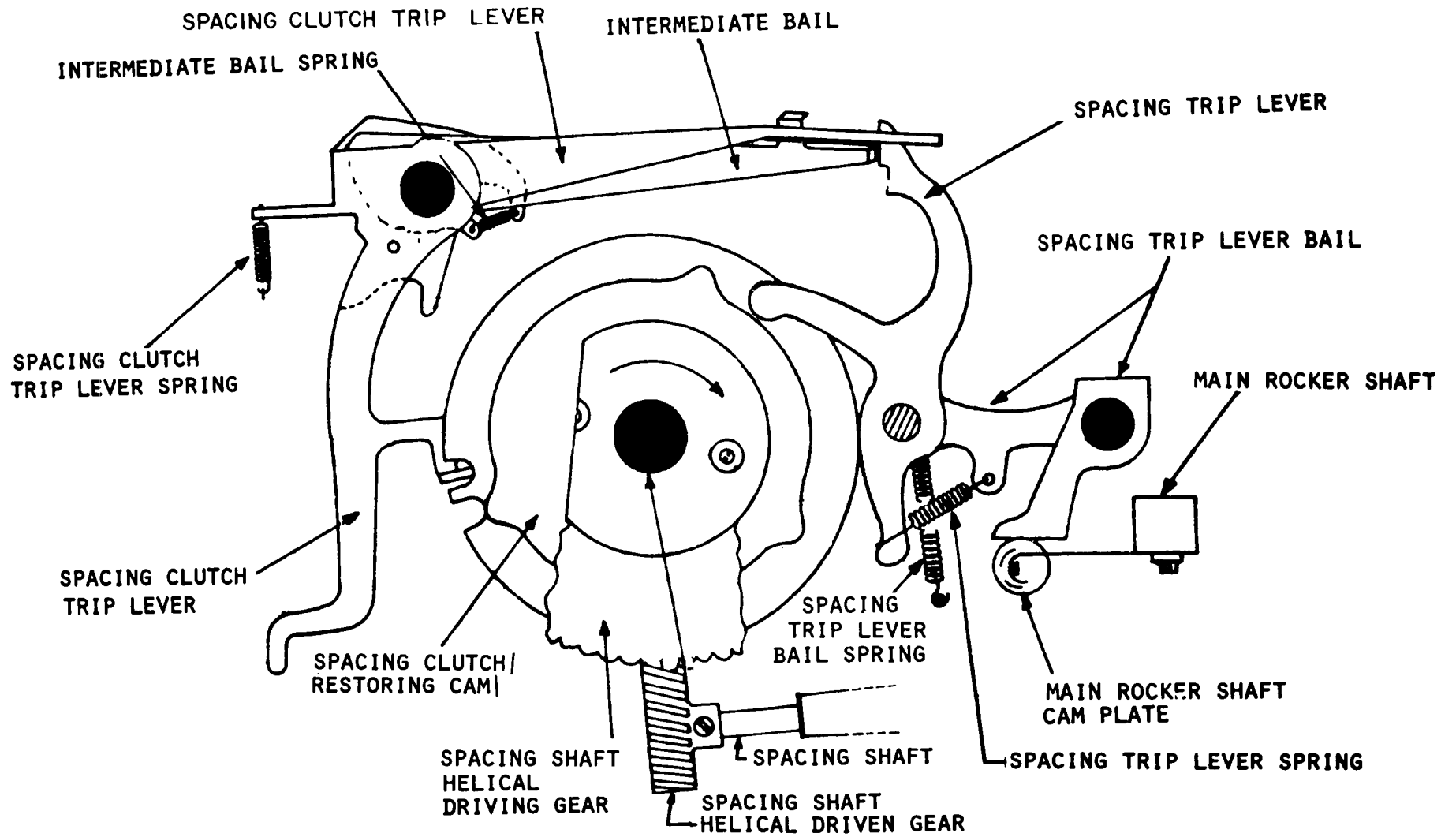

MOD 28 ASR-AN/UGC-6K SPACING TRIP MECHANISM (LEFT VIEW)

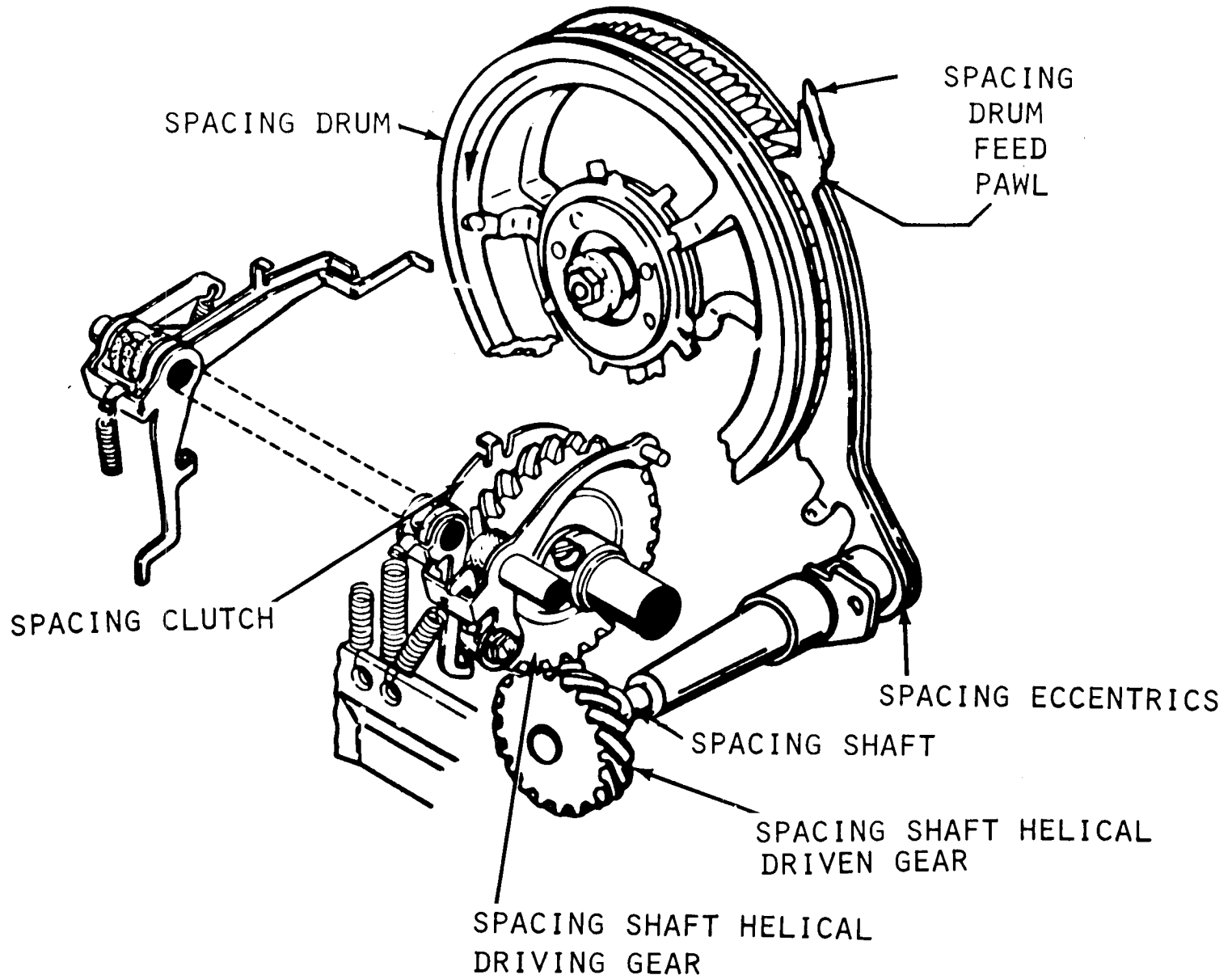

MOD 28 ASR-AN/UGC-6K SPACING FEED PAWLS (REAR VIEW)

SPACING DRUM FEED PAWLS

SPACING DRUM

TRANSFER SLIDE SPRING

STOP RING

STOP ARM

STOP ARM ROLLER

TRANSFER SLIDE

SPACING ECCENTRICS

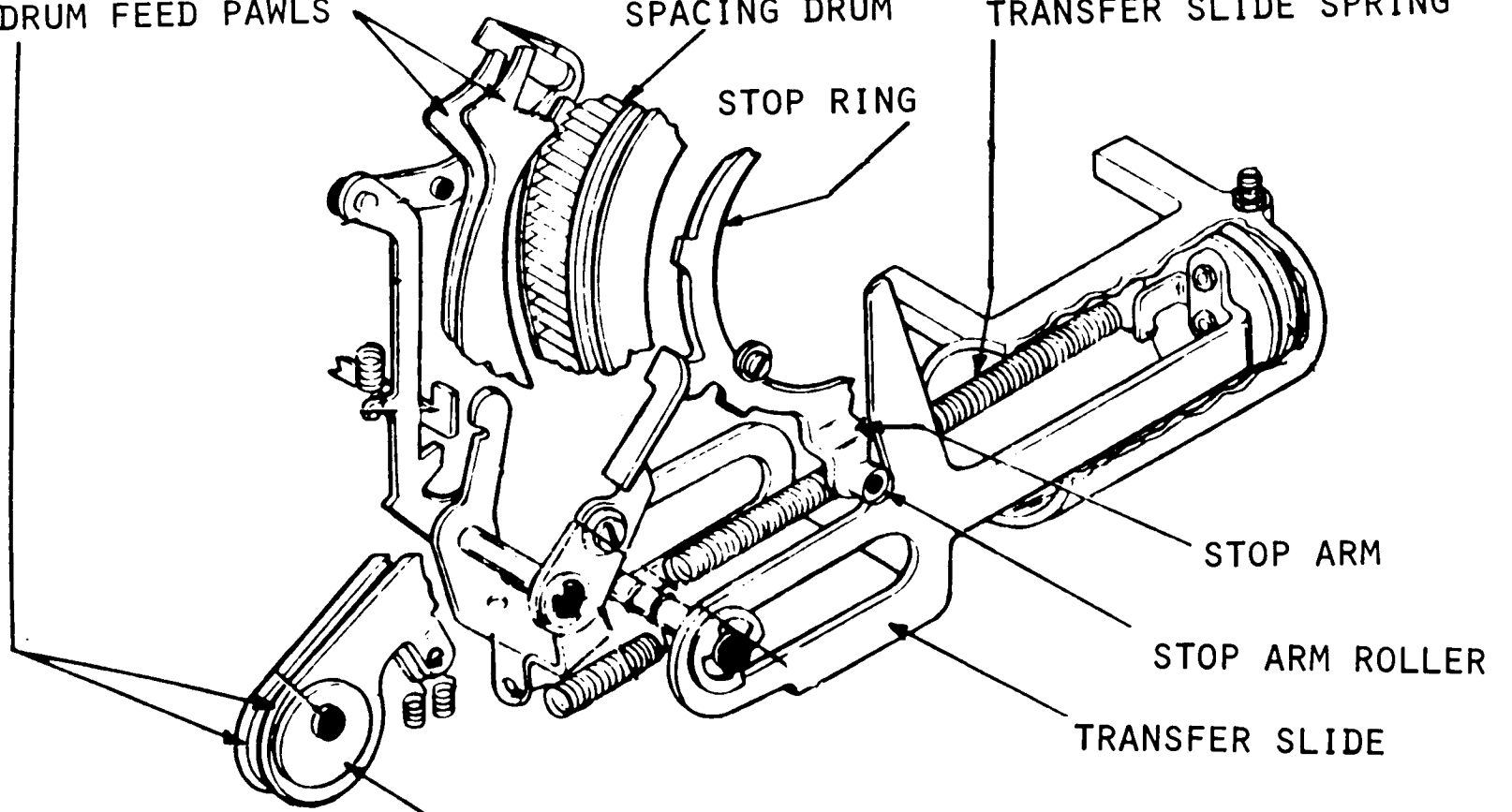

38

MOD 28 ASR AN/UGC-6K SPACING MECHANISM #1

2-3-11D

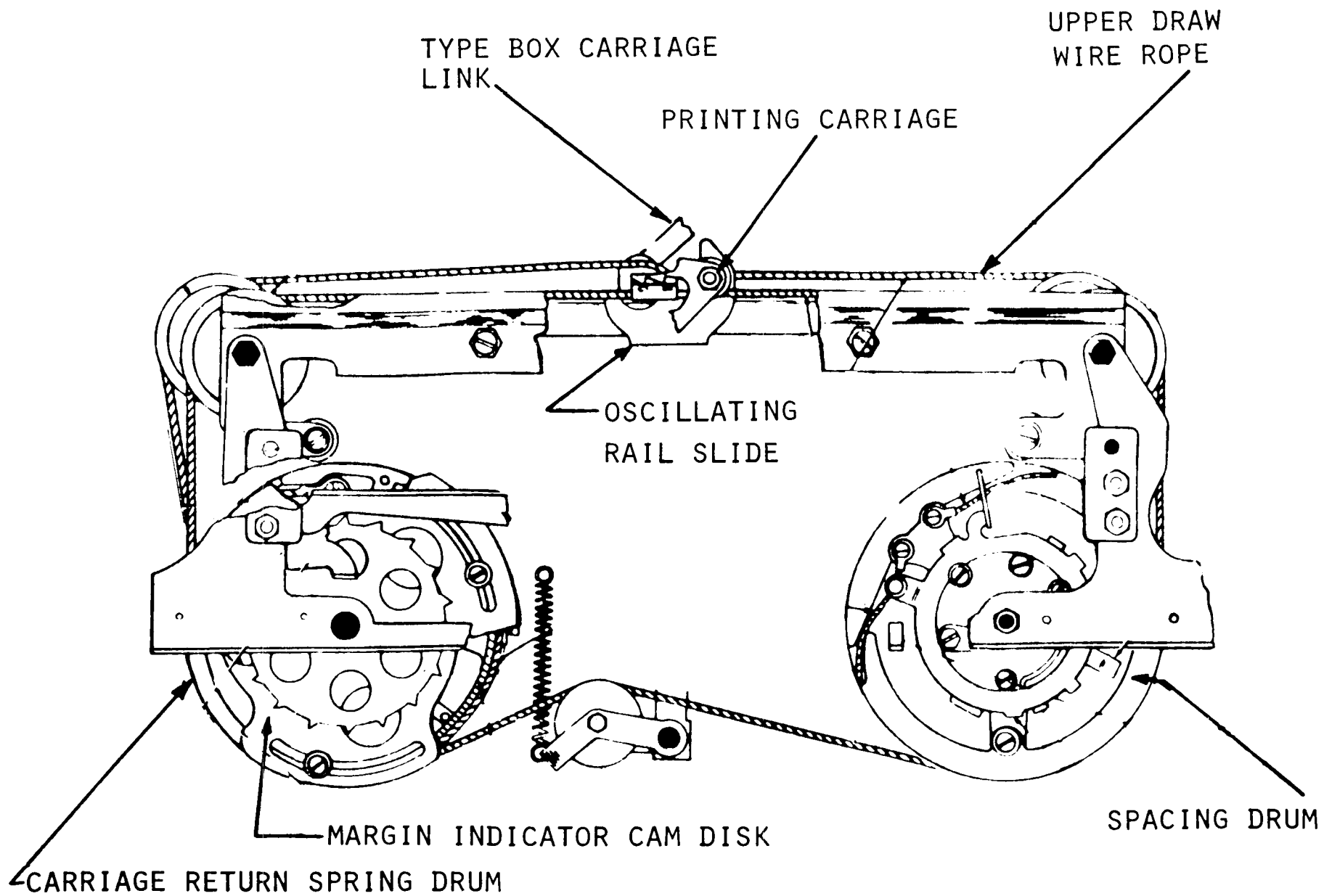

MOD 28 ASR AN/UGC -6K SPACING MECHANISM #2

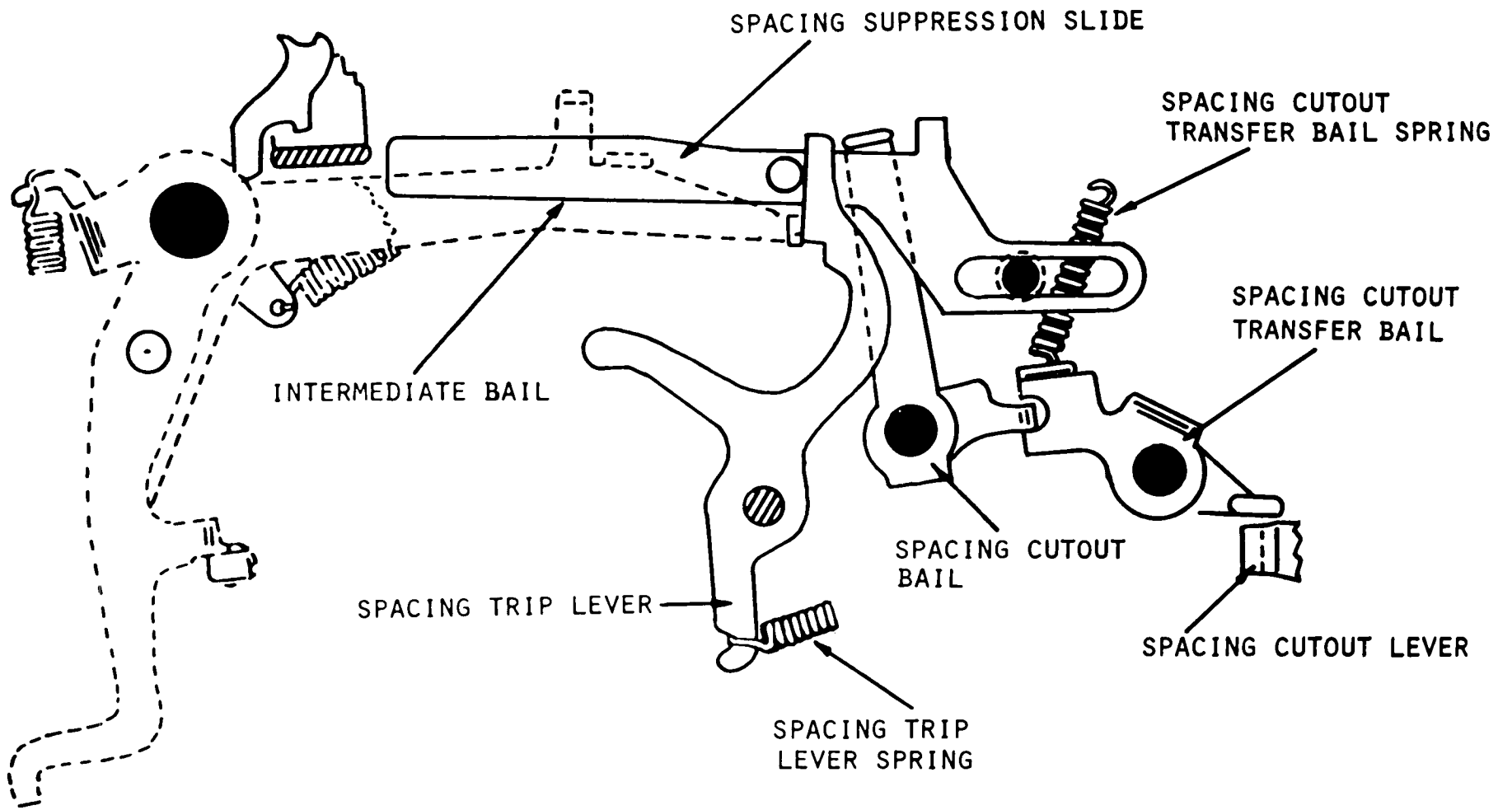

40

MOD 28 ASR-AN/UGC-6K SPACING CUTOUT (LEFT VIEW)

2-3-13D

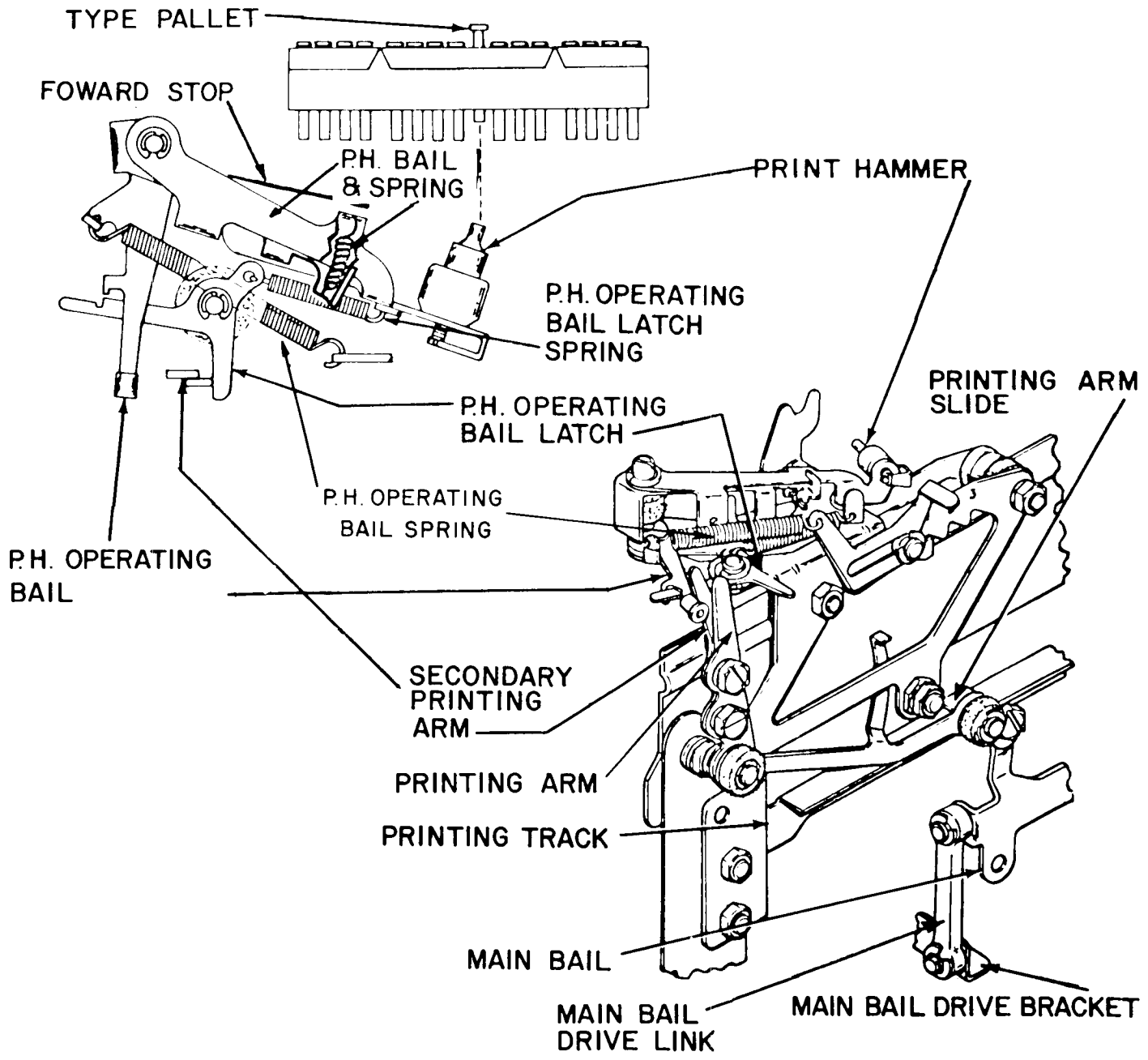

MOD 28 ASR-AN/UGC-6K- PRINTING MECHANISM

42

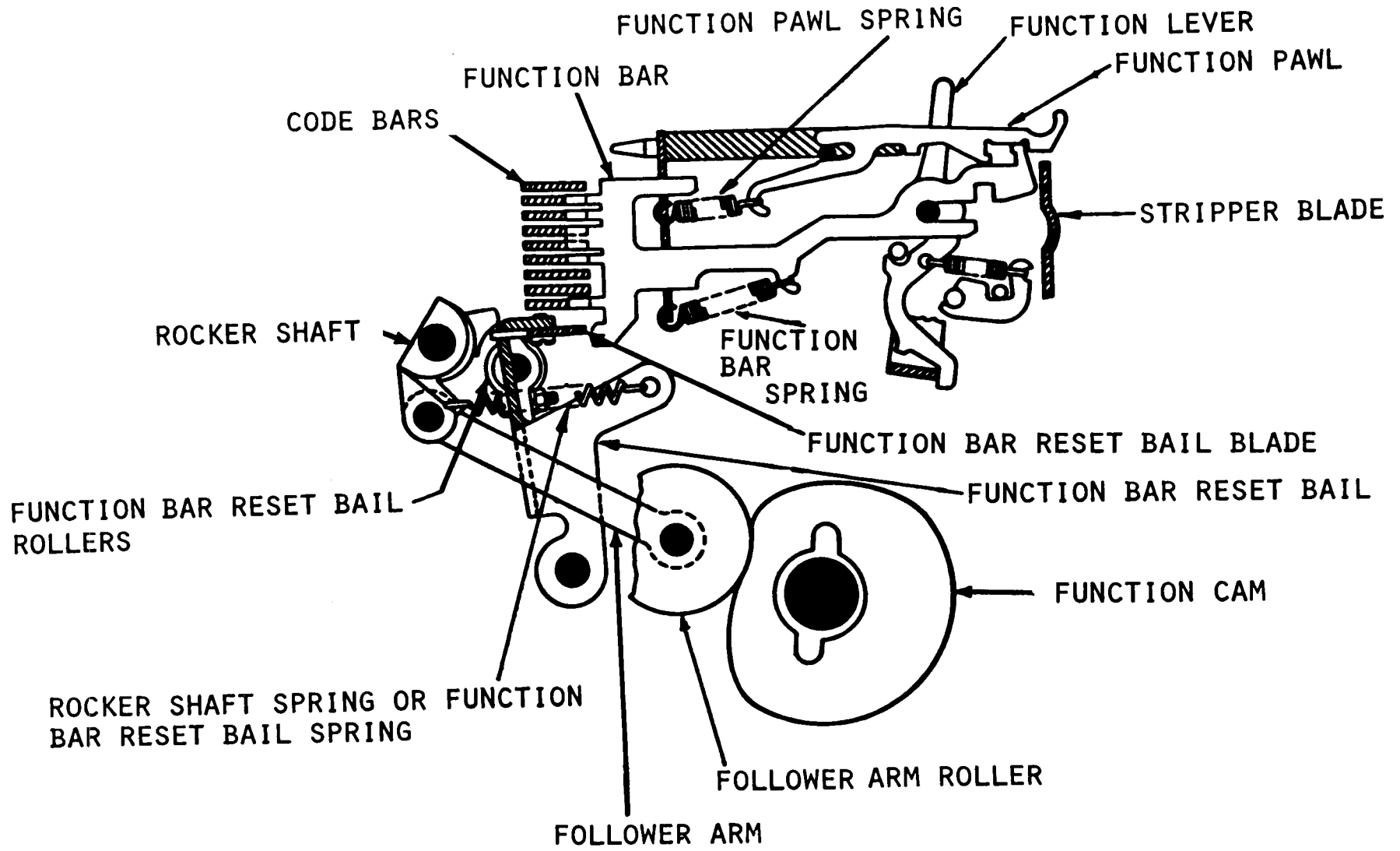

MOD 28 ASR-AN/UGC-6K RESET BAIL (INITIAL POSITION)(RIGHT VIEW)

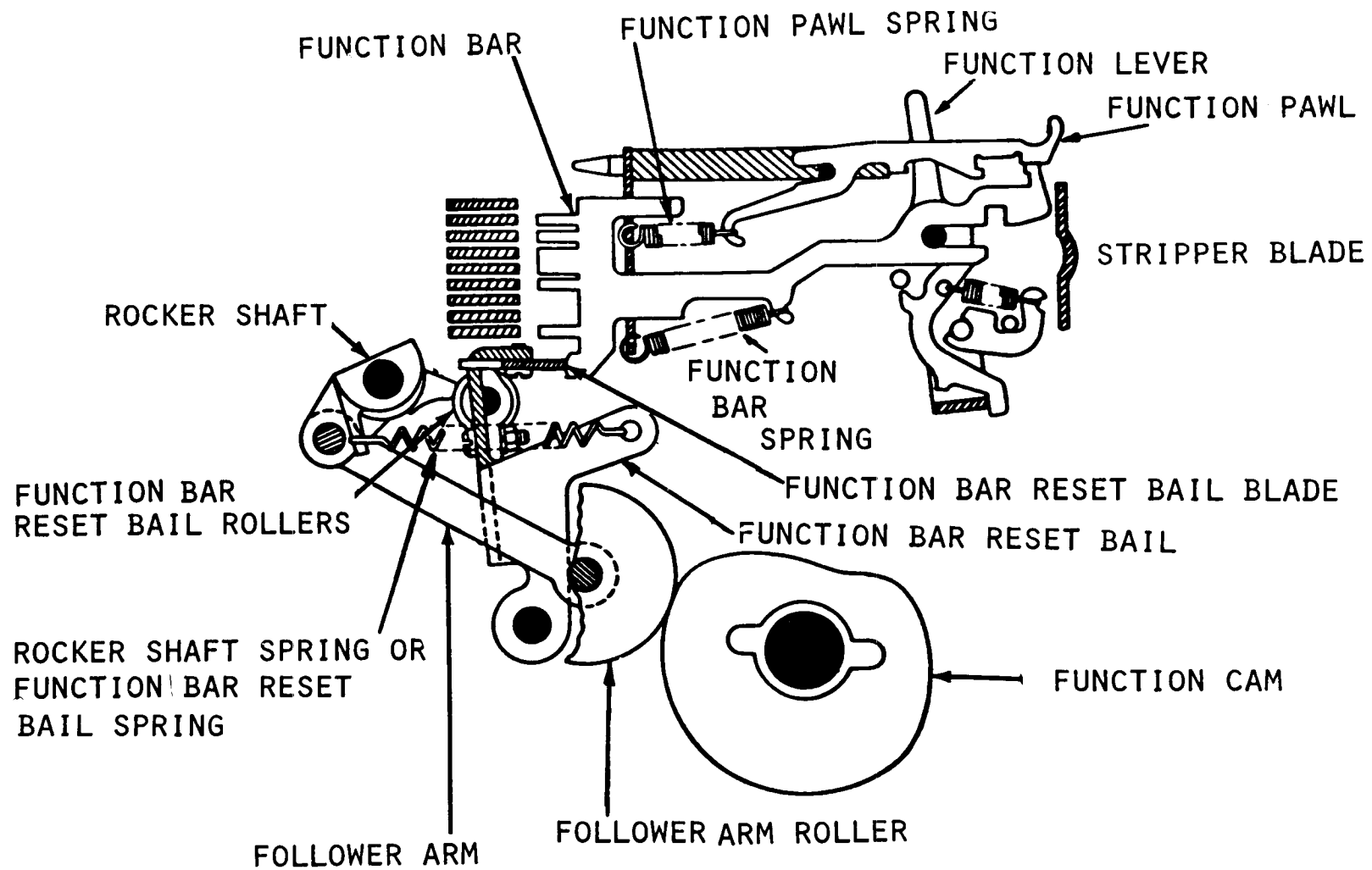

43

MOD 28 ASR/AN/UGC-6K RESET BAIL (FINAL POSITION)(RIGHT VIEW)

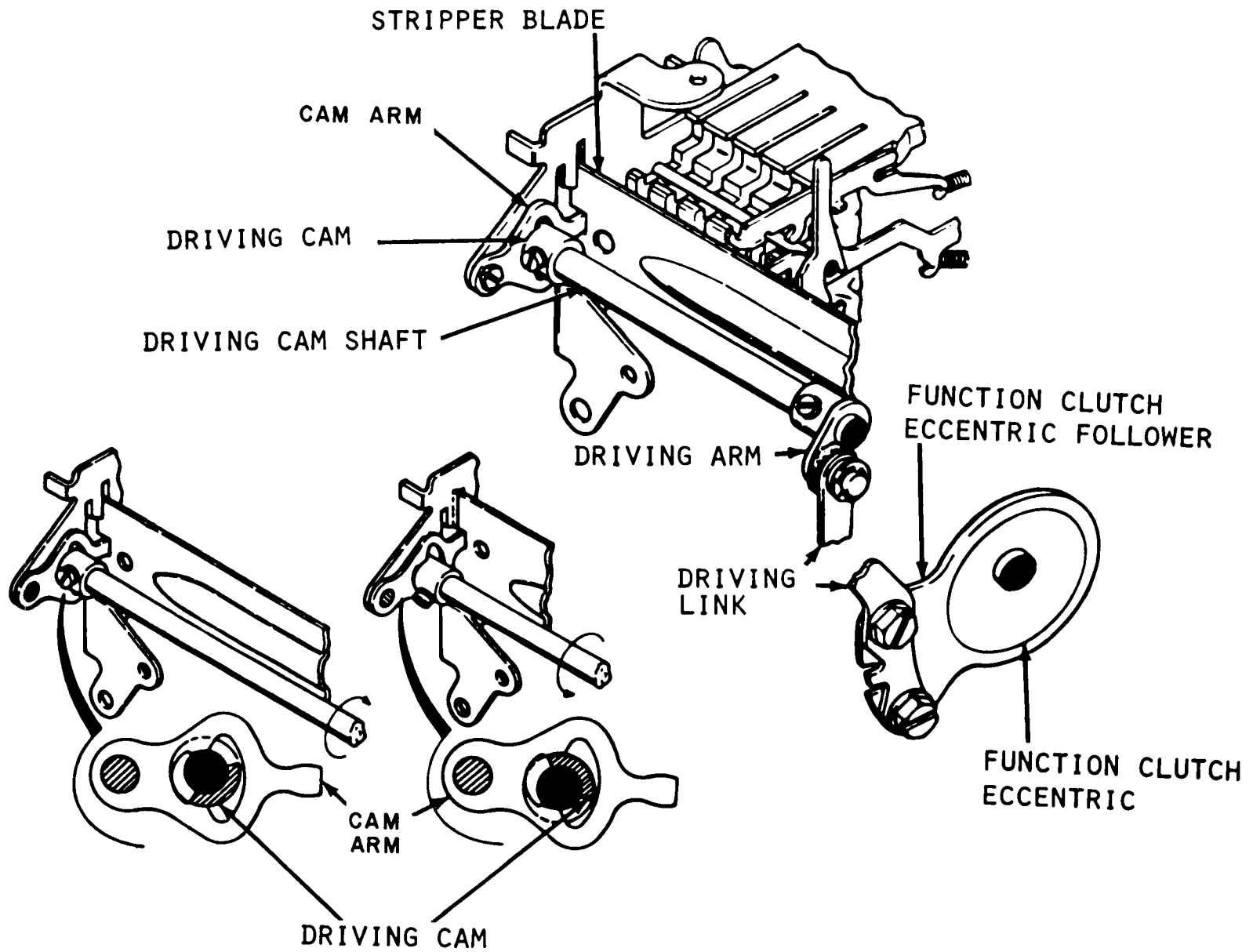

MOD 28 ASR-AN/UGC-6K STRIPPER BLADE (LEFT REAR VIEW)

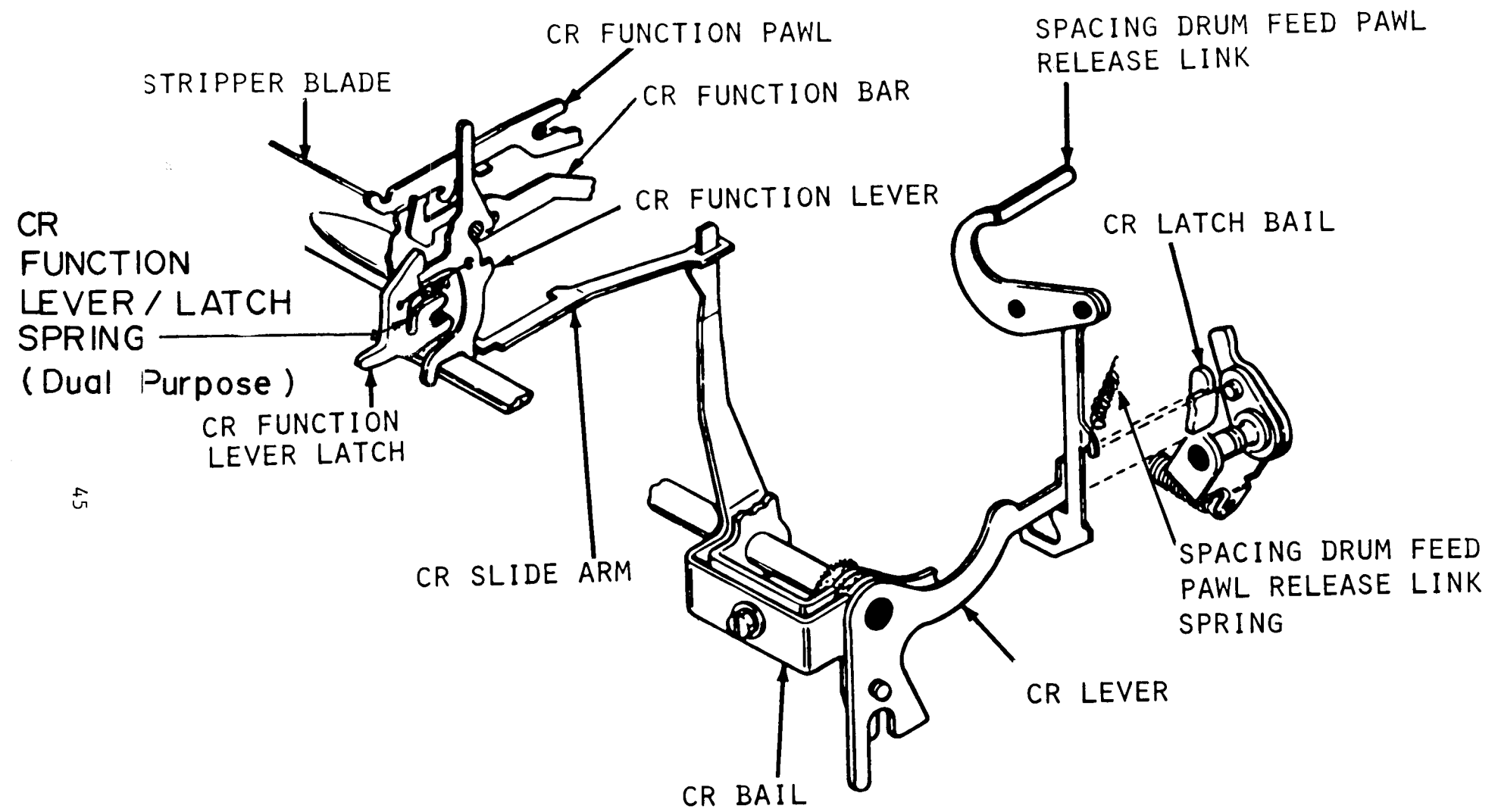

45

MOD 28 ASR-AN/UGC-6K CARRIAGE RETURN MECHANISM #1 (LEFT VIEW)

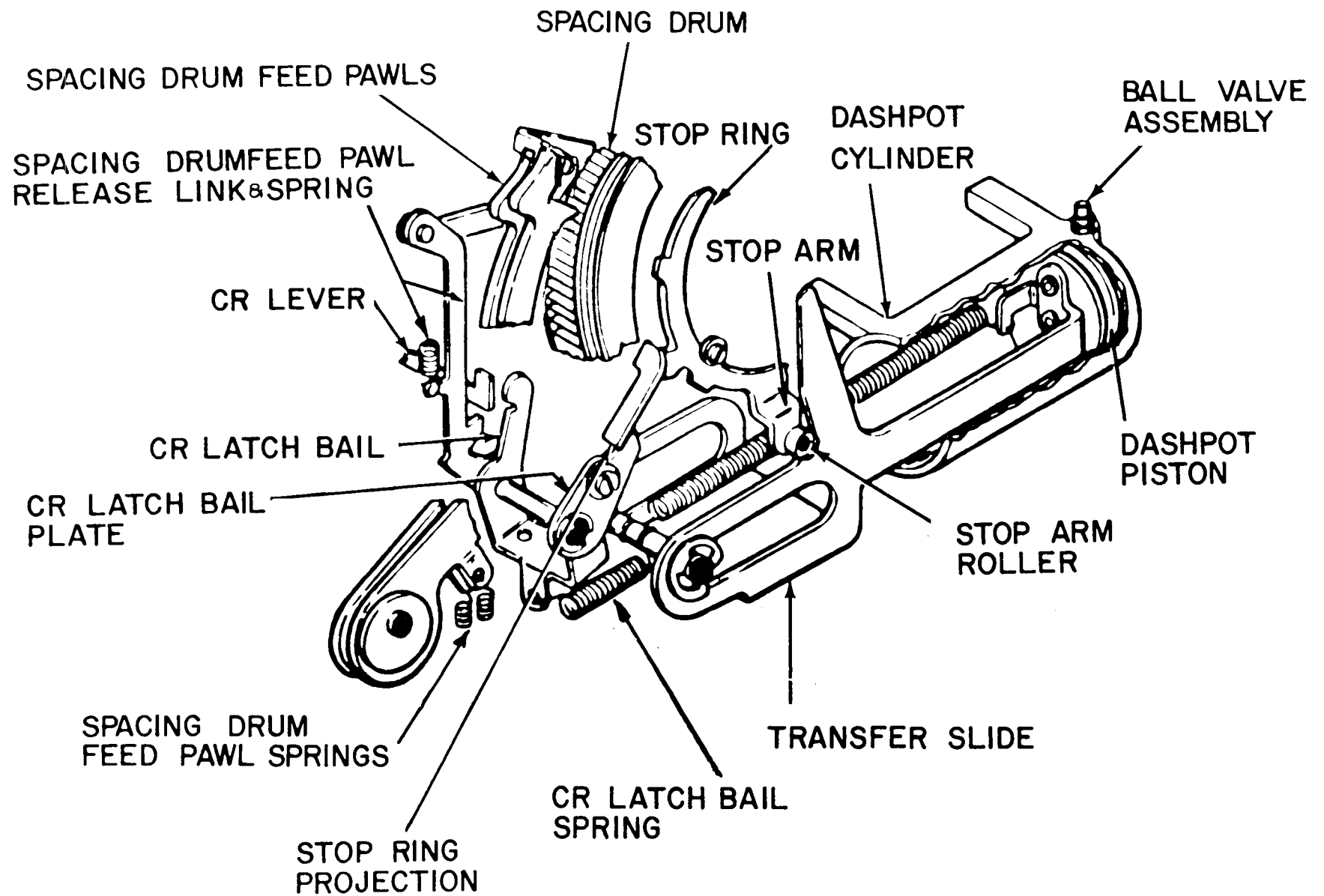

97

MOD 28 ASR-AN/UGC-6K CARRIAGE RETURN MECHANISM No. 2

2-4-6D

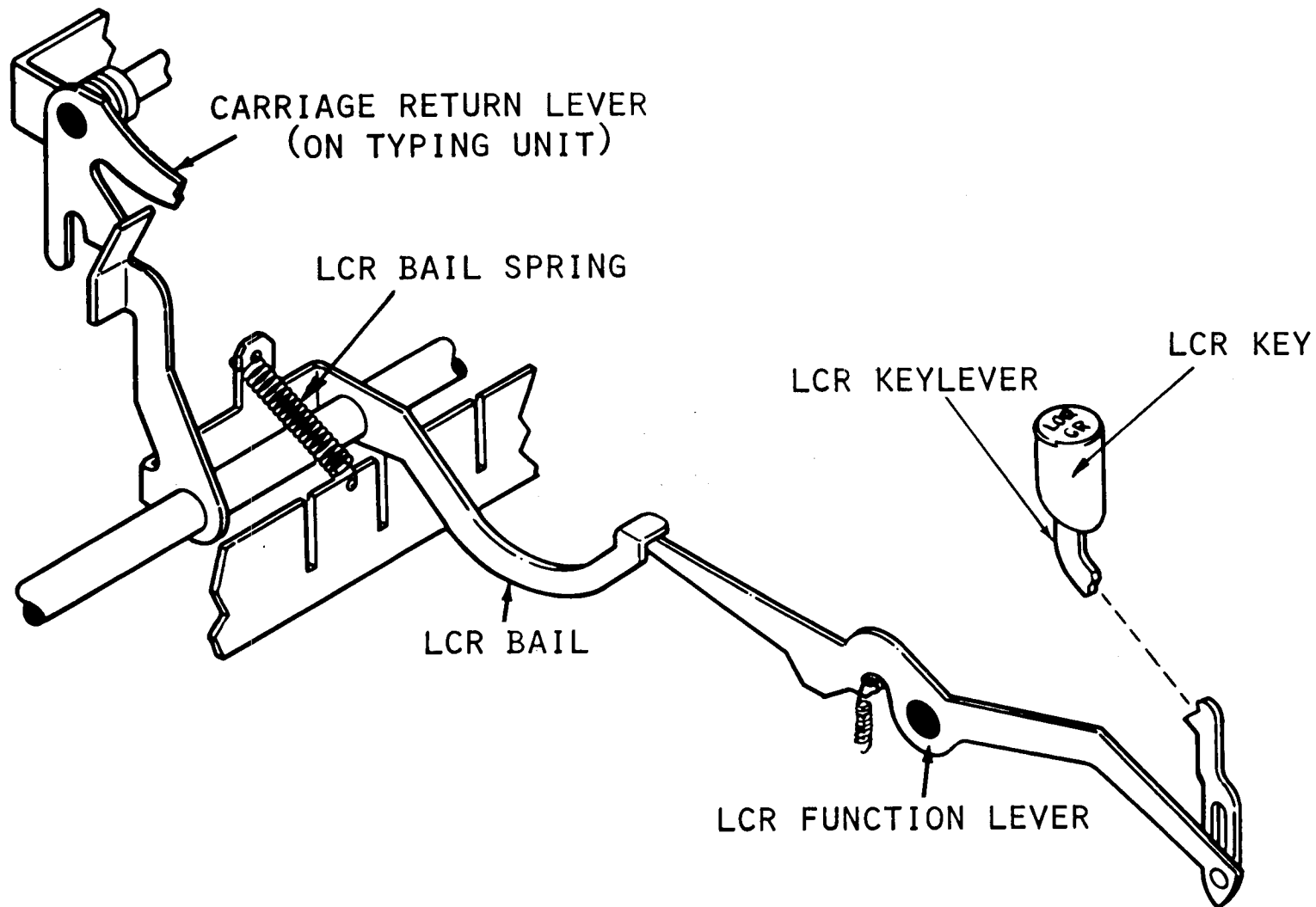

47

MOD 28 ASR AN/UGC-6K LOCAL CARRIAGE RETURN (LCR) MECHANISM (LEFT VIEW)

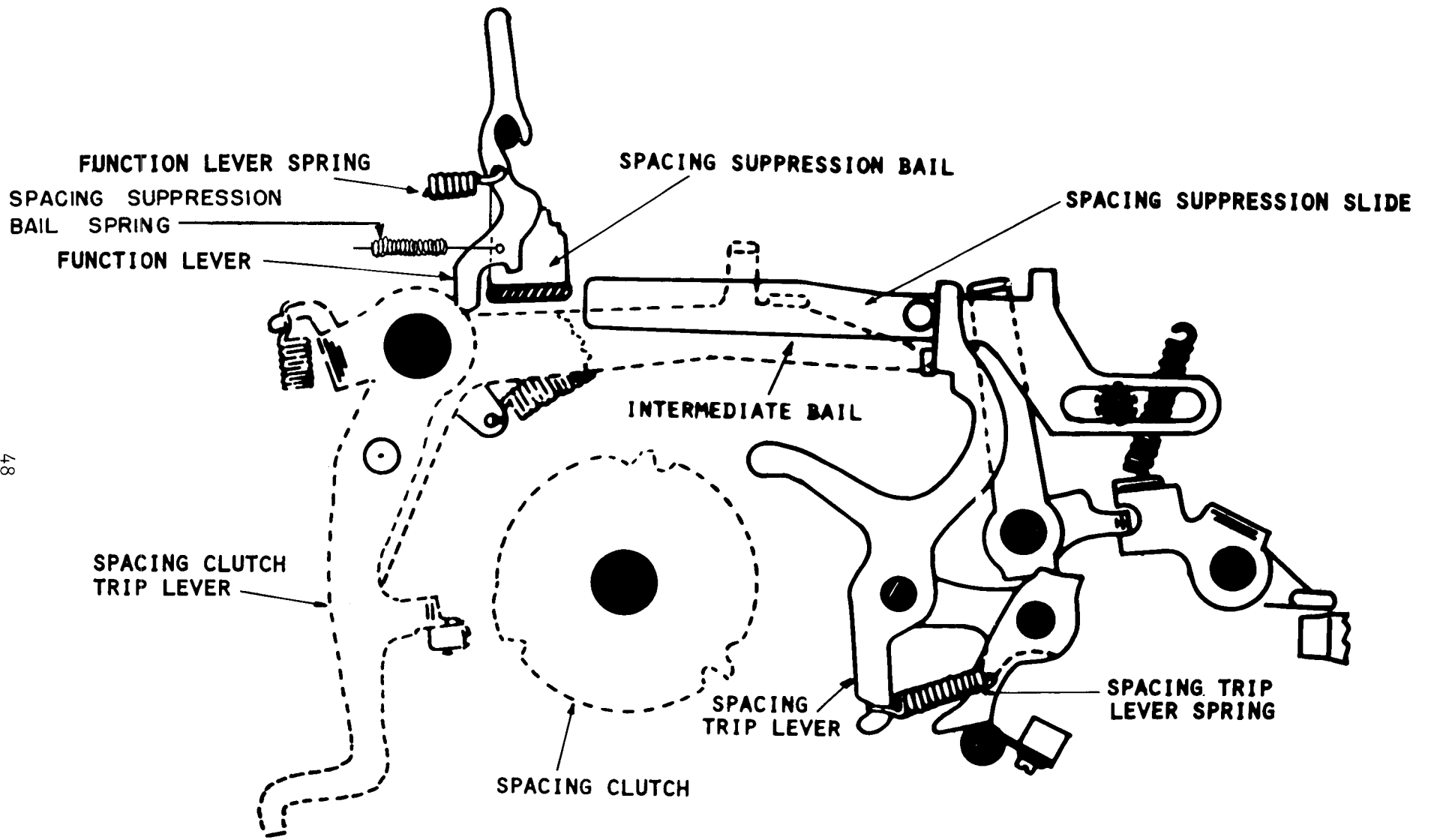

MOD 28 ASR-AN/UGC-6K SPACING SUPPRESSION (LEFT VIEW)

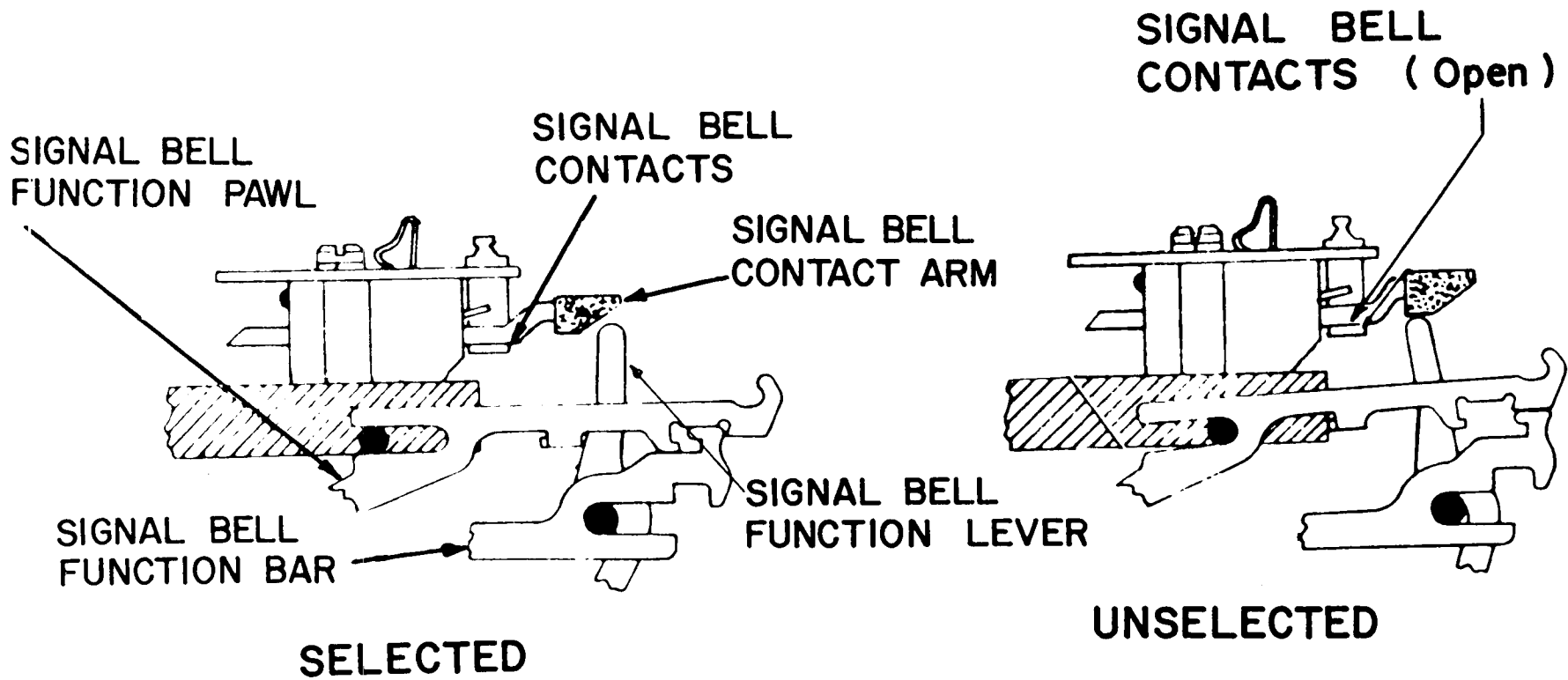

MOD 28 ASR-AN/UGC-6K SIGNAL BELL FUNCTION (RIGHT VIEW)

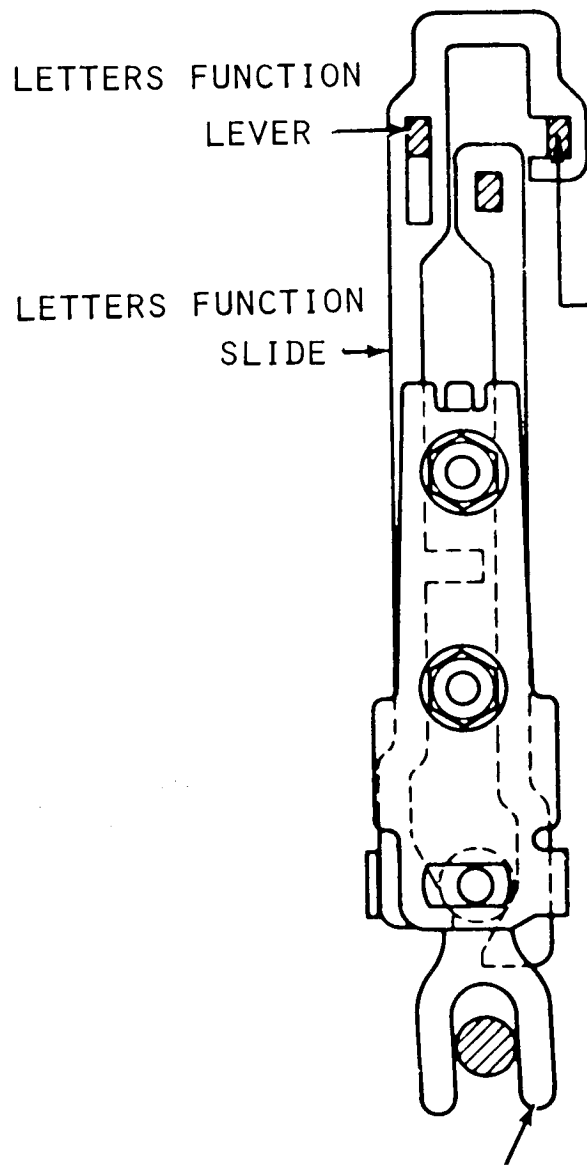

LTRS-FIGS CODE BAR FORK
LETTERS SHIFT

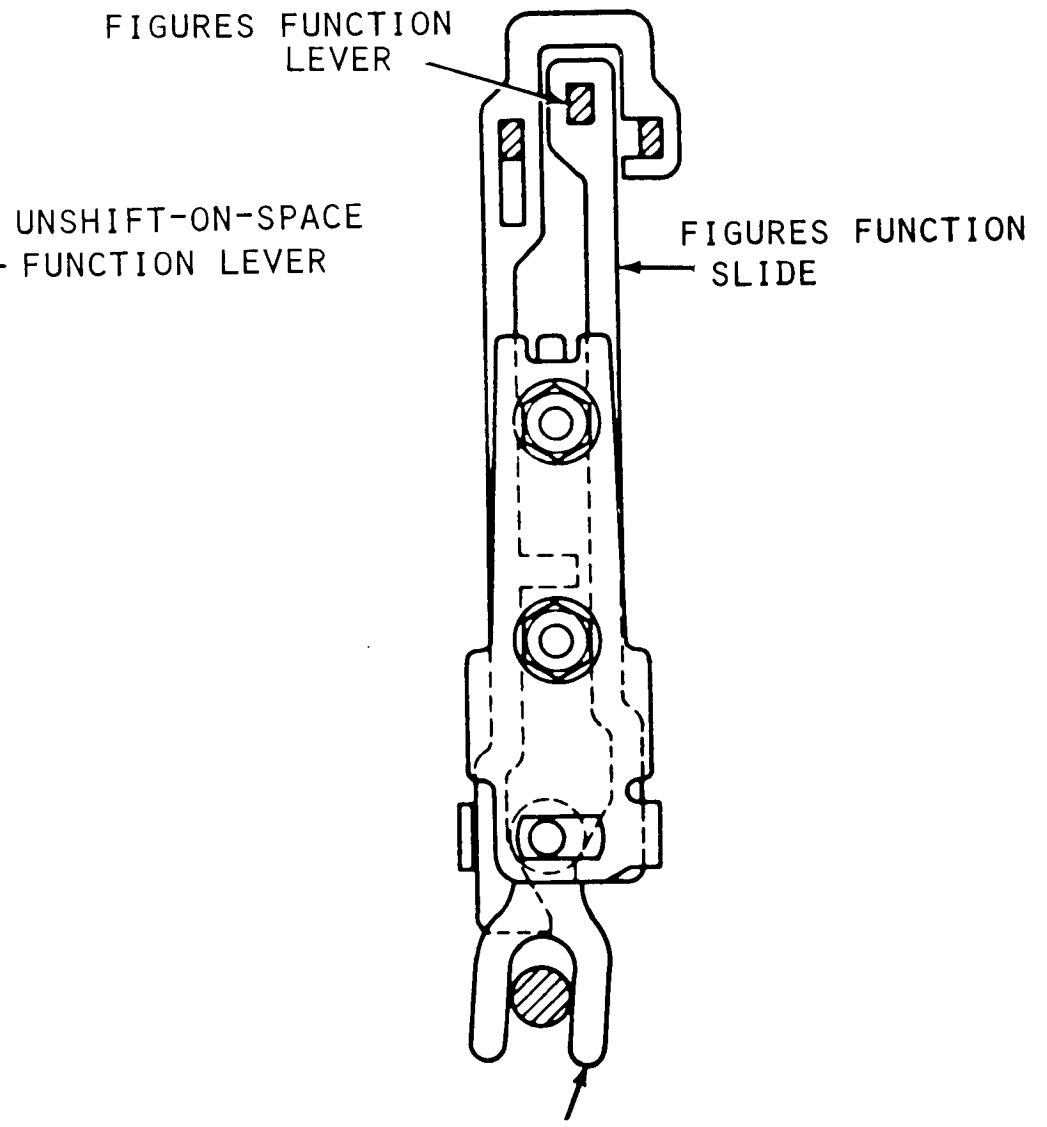

LTRS-FIGS CODE BAR FORK
FIGURES SHIFT

MOD 28 ASR-AN/UGC-6K LETTERS FIGURES SHIFT SLIDES (TOP VIEW)

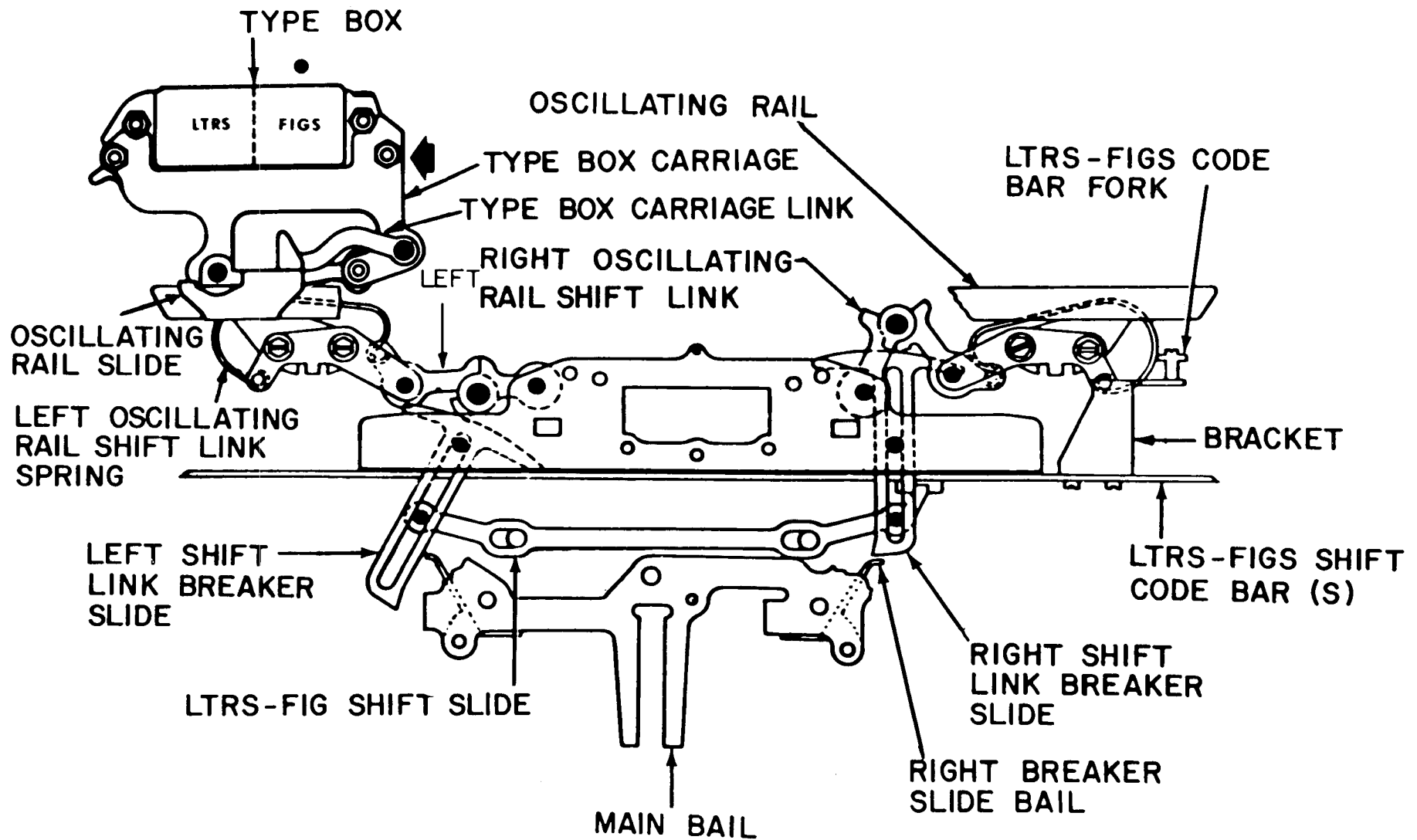

MOD 28 ASR-AN/UGC-6K - FIGURES SHIFT

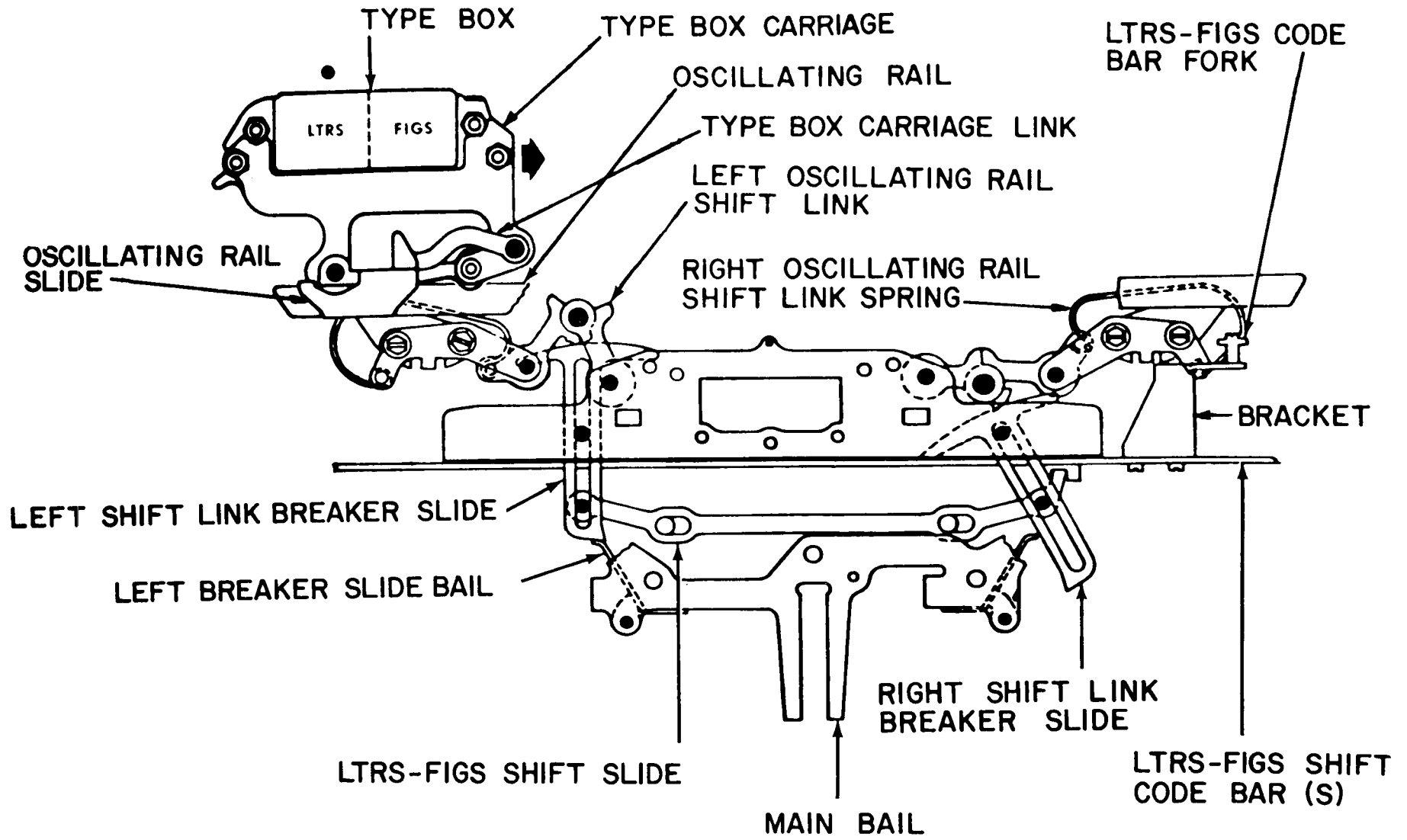

MOD 28 ASR-AN/UGC-6K LETTERS SHIFT

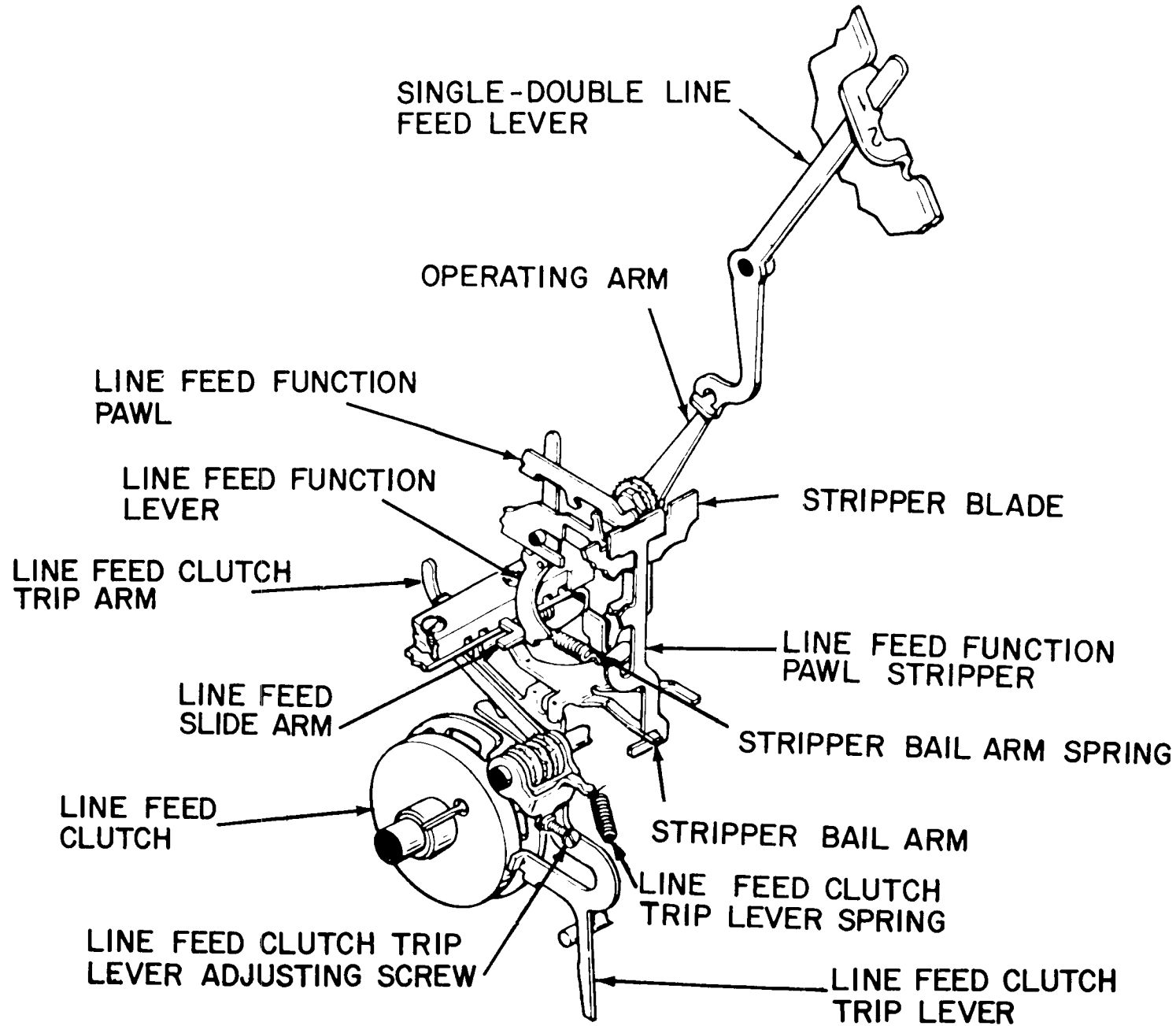

MOD 28 ASR-AN/UGC-6K

DOUBLE LINEFEED (RIGHT REAR VIEW)

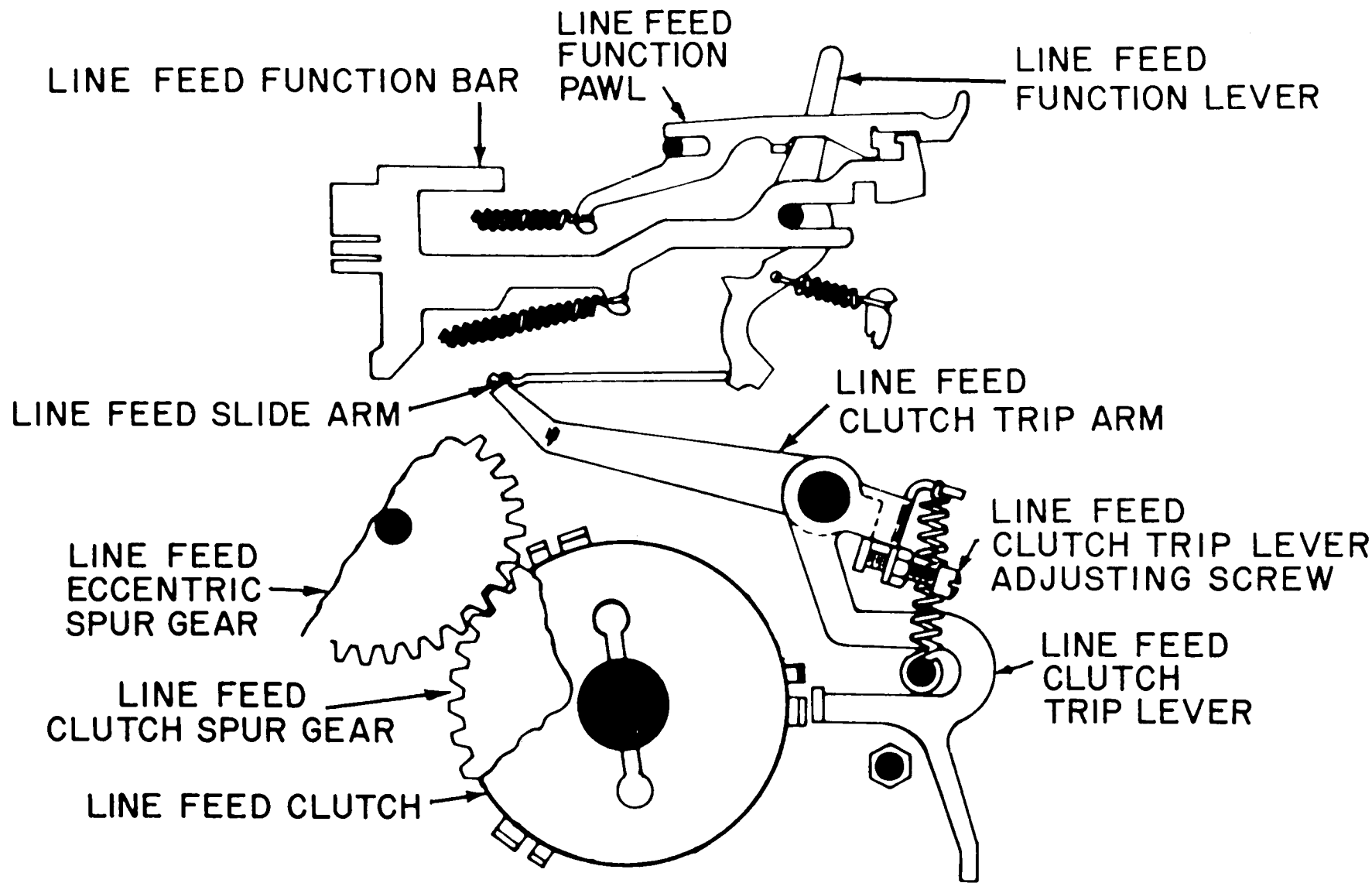

MOD 28 ASR-AN/UGC-6K-LINE FEED FUNCTION (RIGHT VIEW)

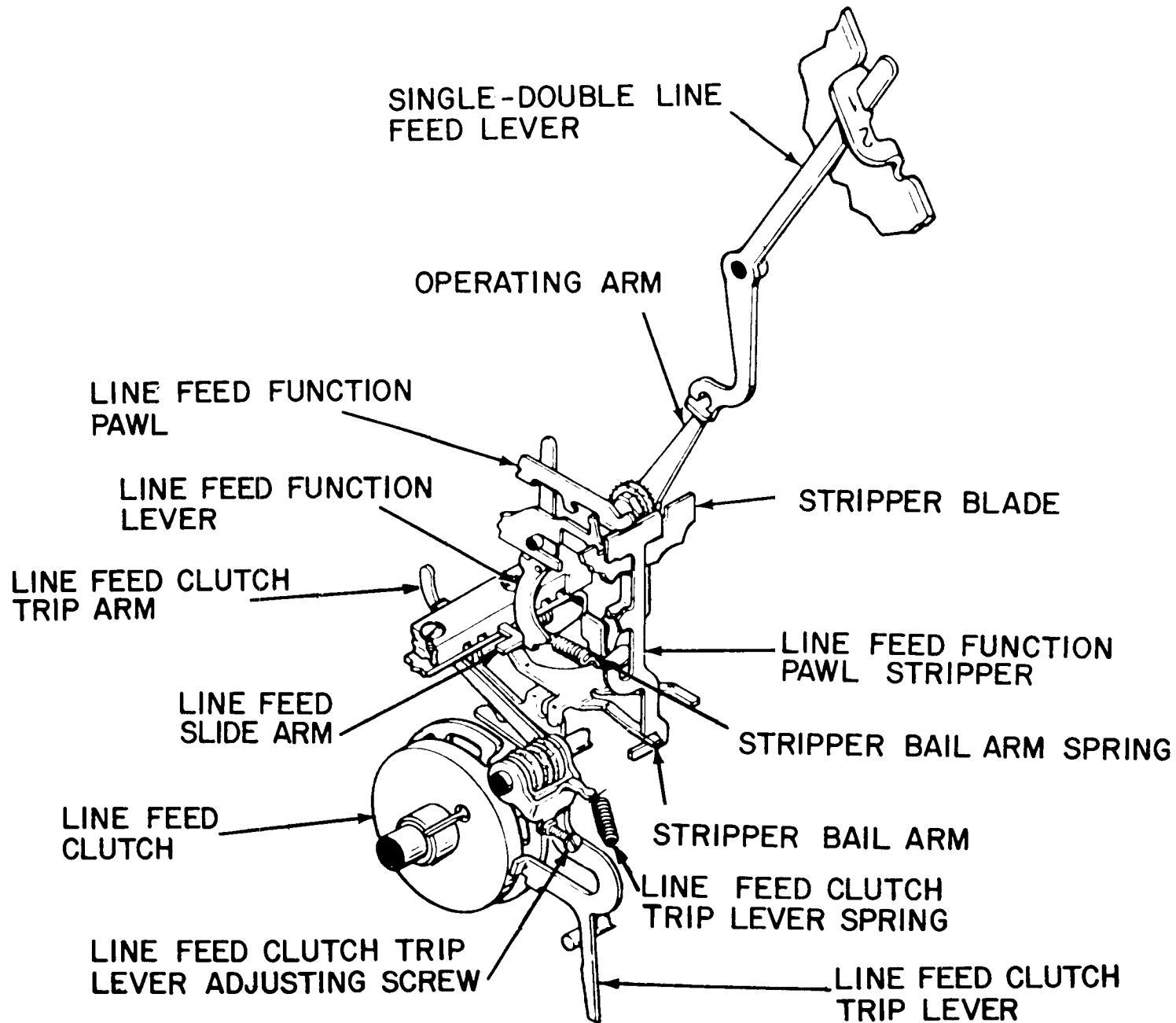

MOD 28 ASR-AN/UGC-6K DOUBLE LINEFEED (RIGHT REAR VIEW)

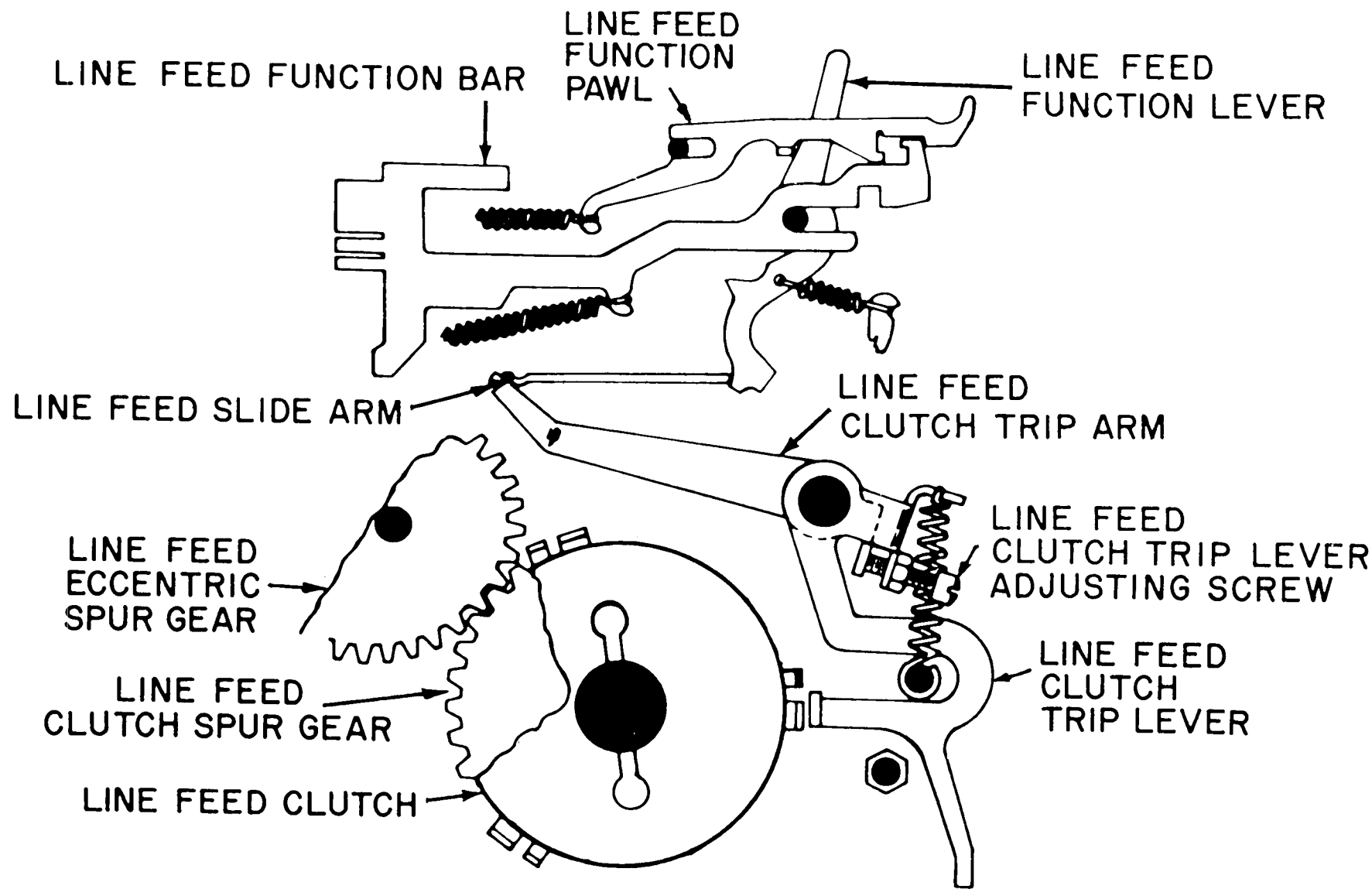

54

MOD 28 ASR-AN/UGC-6K-LINE FEED FUNCTION (RIGHT VIEW)

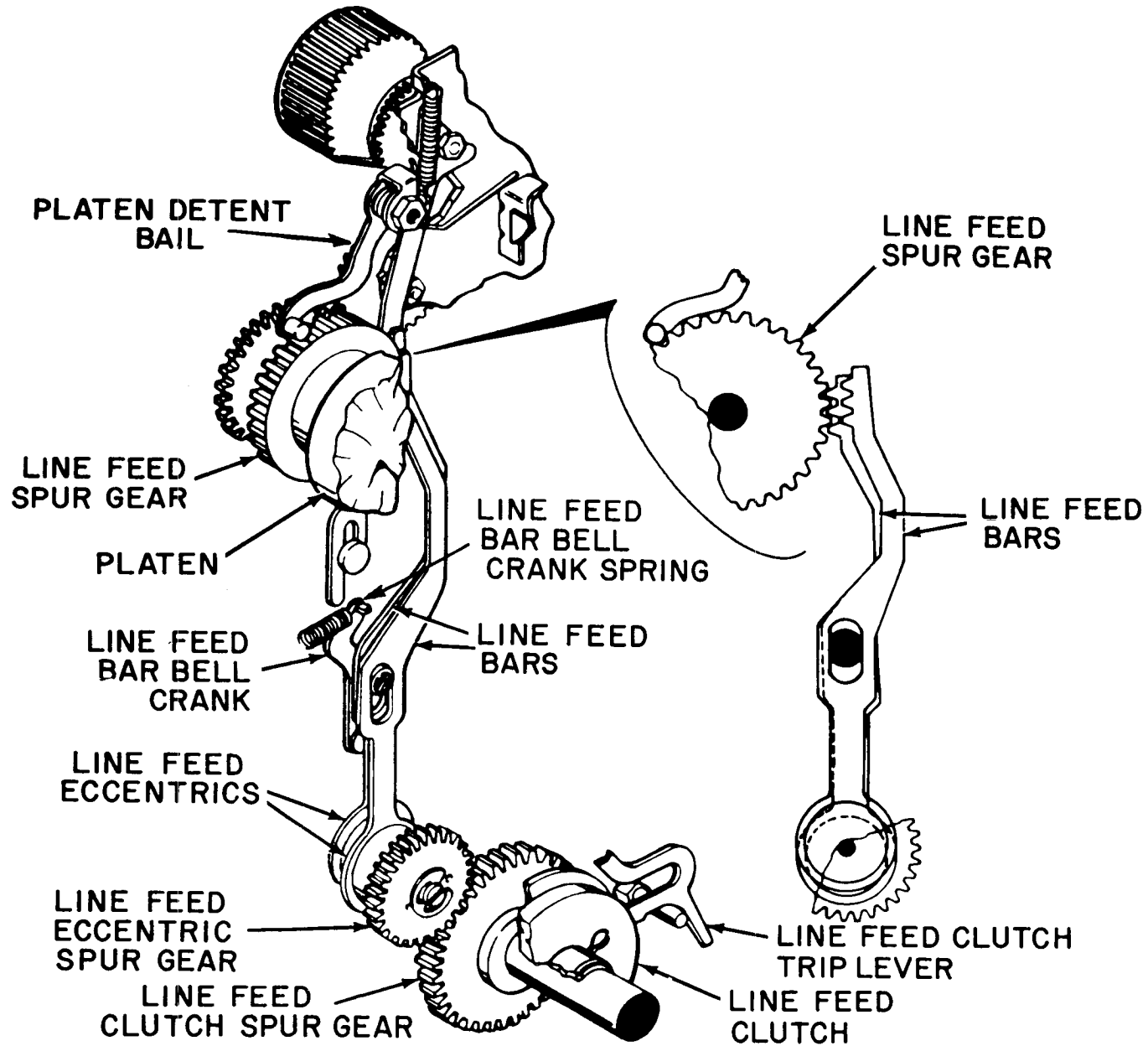

MOD 28 ASR-AN/UGC-6K-LINE FEED MECHANISM (RIGHT VIEW)

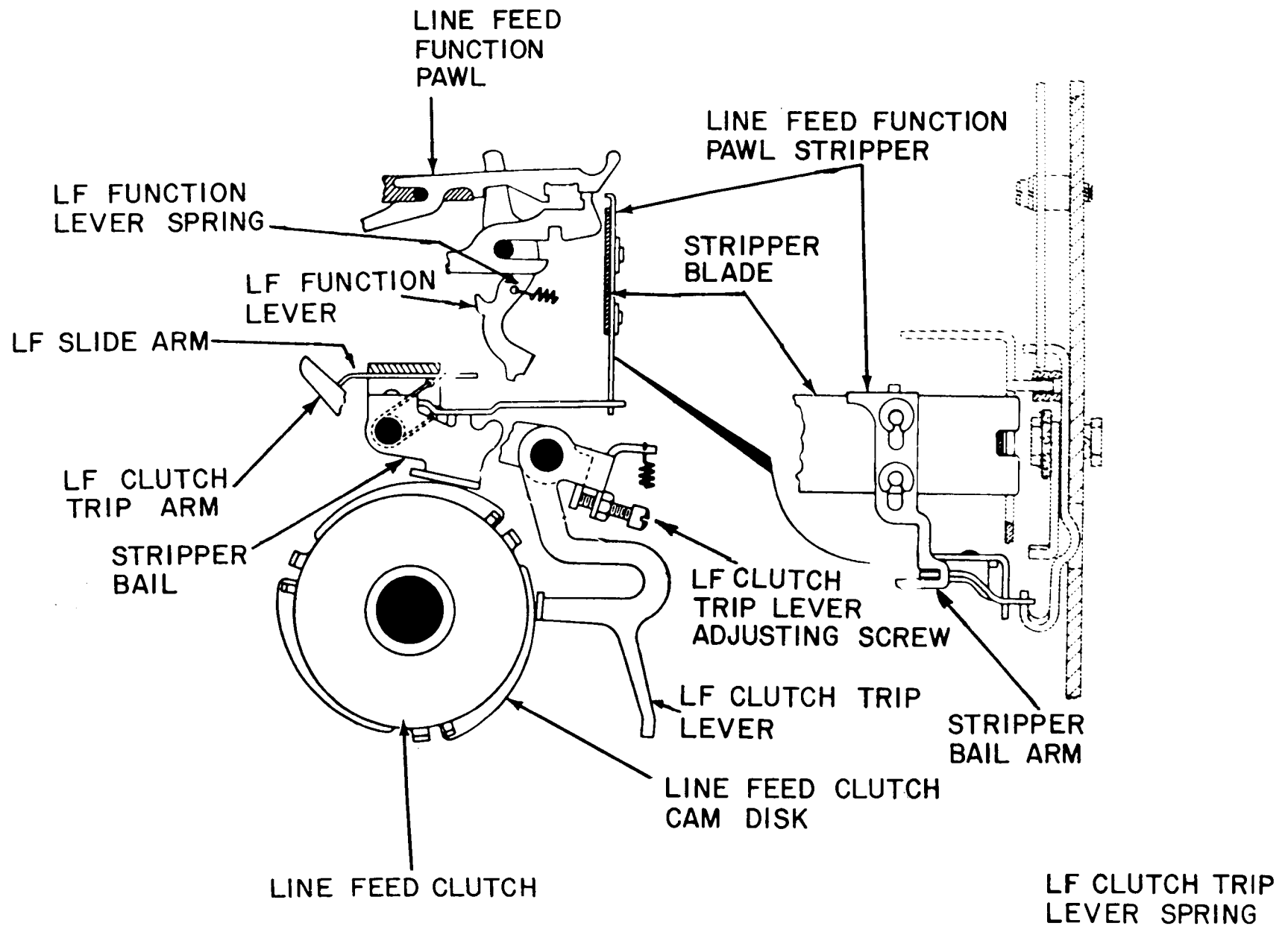

MOD 28 ASR-AN/UGC-6K-SINGLE LINE FEED (RIGHT VIEW)

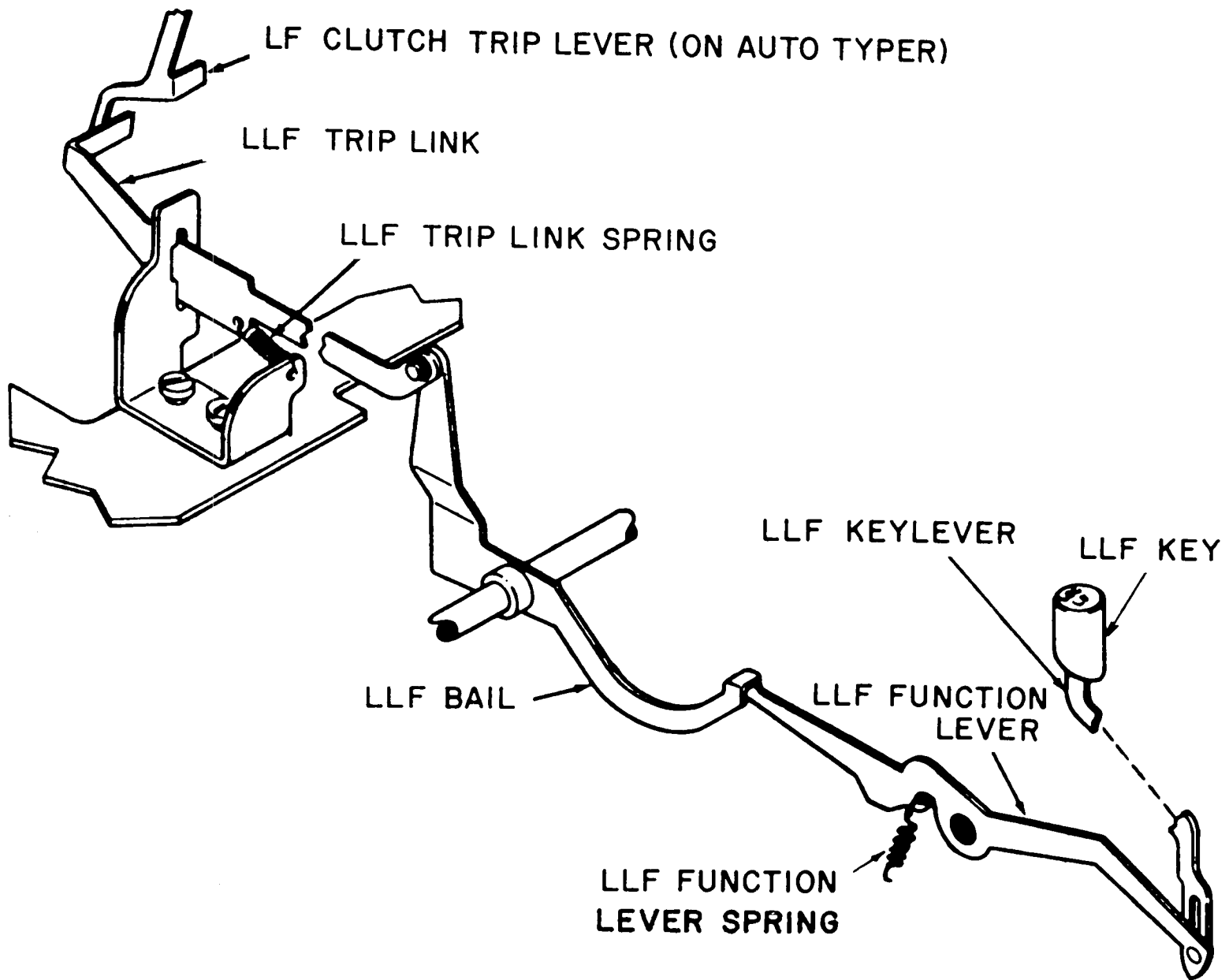

MOD 28 ASR - AN/UGC - 6K - LOCAL LINEFEED (LLF)
(LEFT FRONT VIEW)

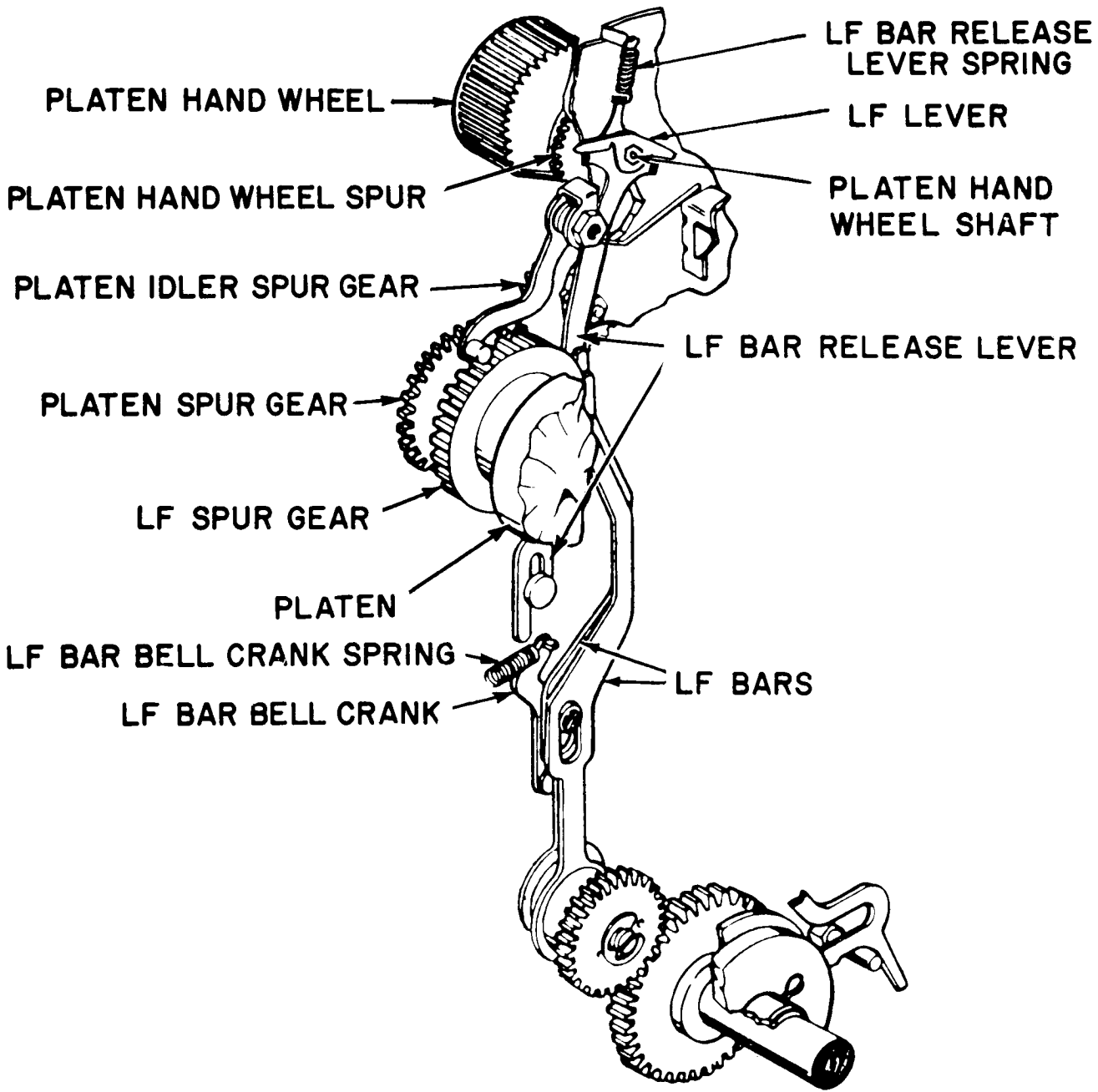

MOD 28 ASR-AN/UGC-6K-MANUAL LINE FEED (RIGHT VIEW)

2-4-18D

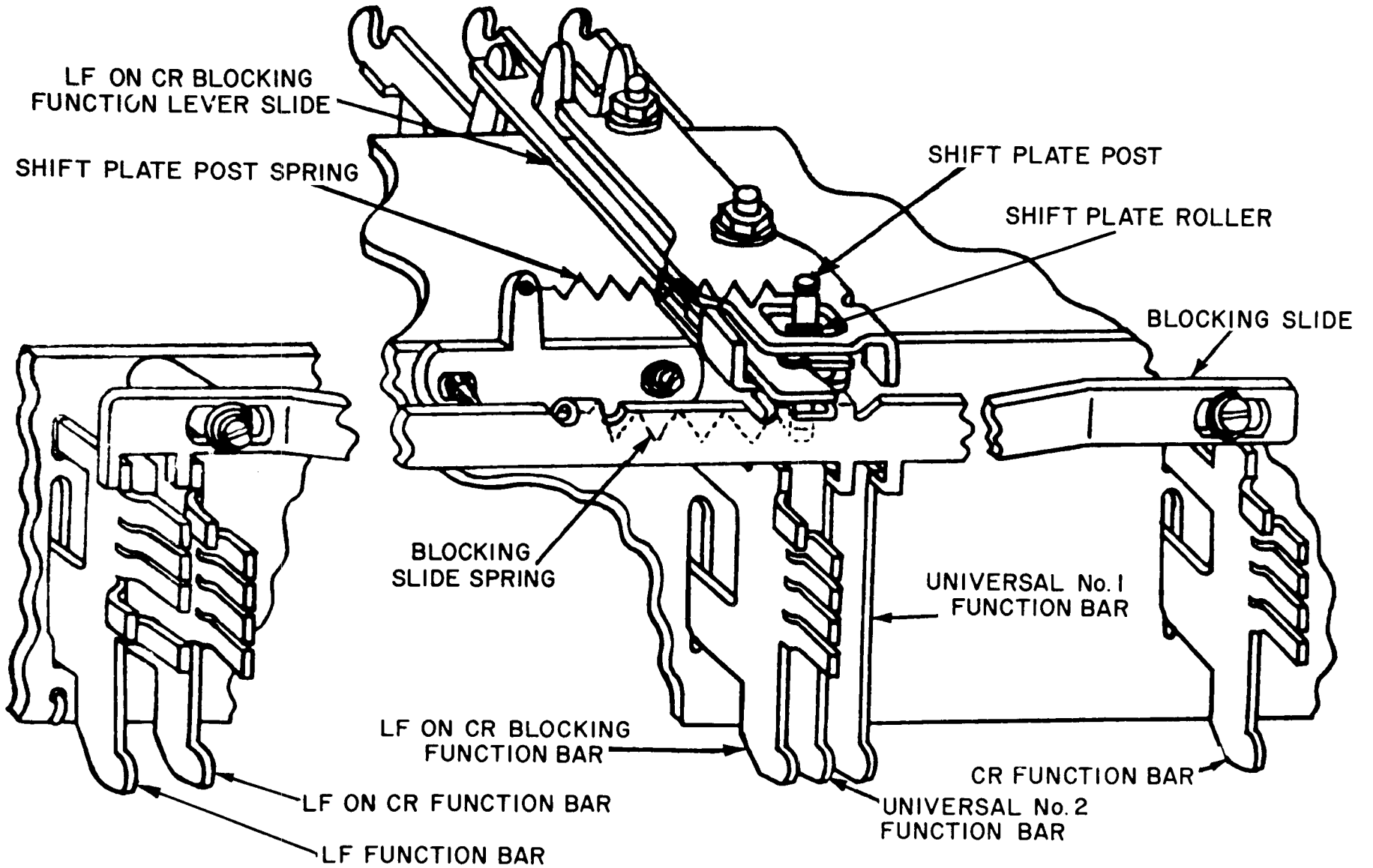

MOD 28 ASR -AN/UGC -6K -AUTOMATIC LINEFEED ON CARRIAGE RETURN

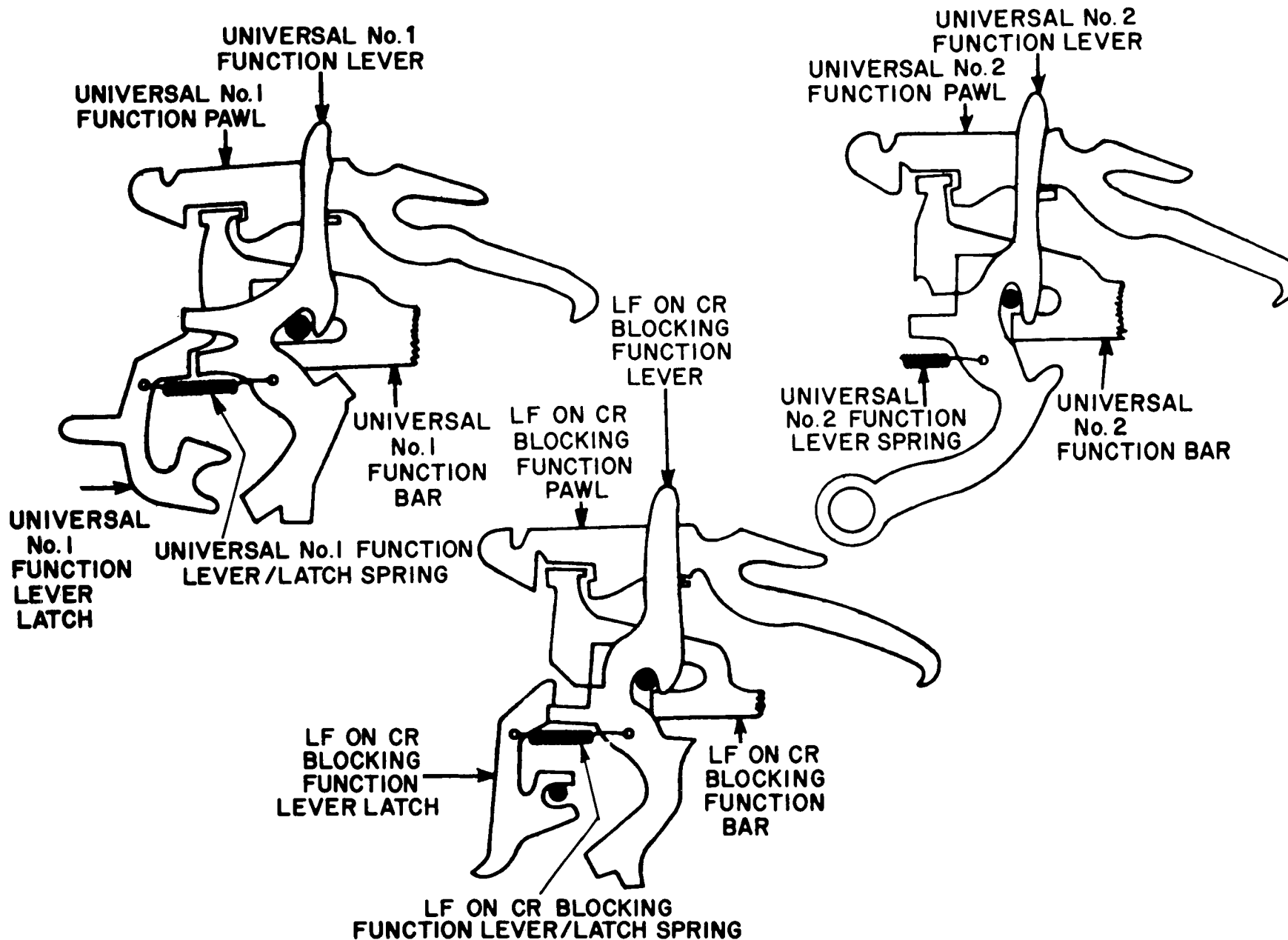

MOD 28 ASR-AN/UGC-6K- UNIVERSAL MECHANISM (LEFT VIEW)

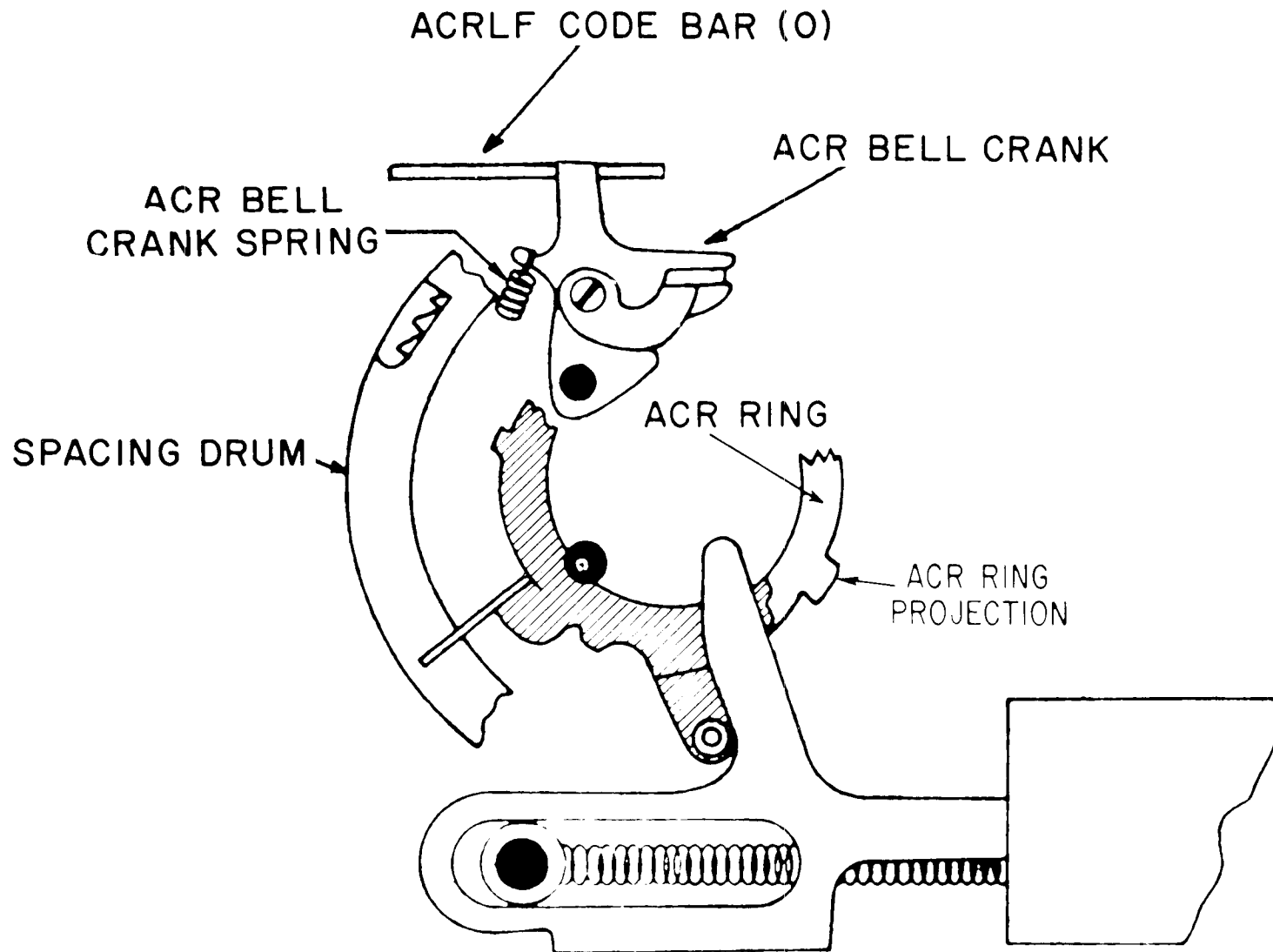

MOD 28 ASR-AN/UGC-6K - AUTOMATIC CARRIAGE RETURN (ACR)
AND LINE FEED (LF)

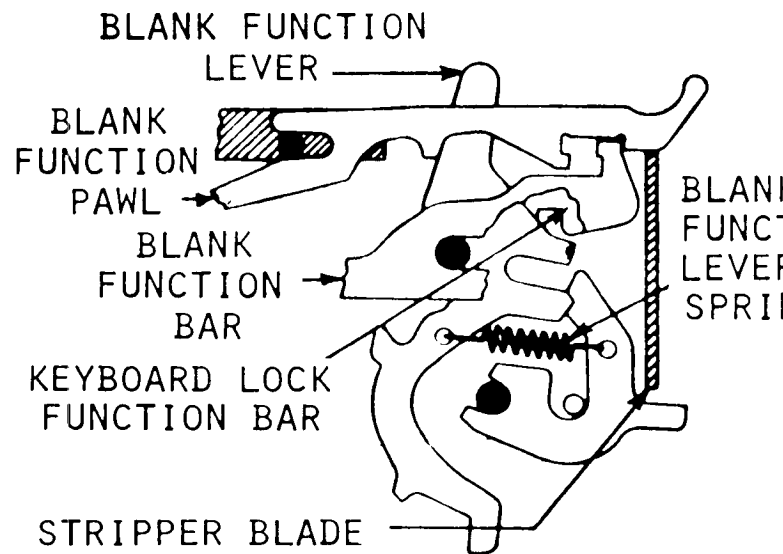

Keyboard Lock Priming Mechanism
(Right Side View)

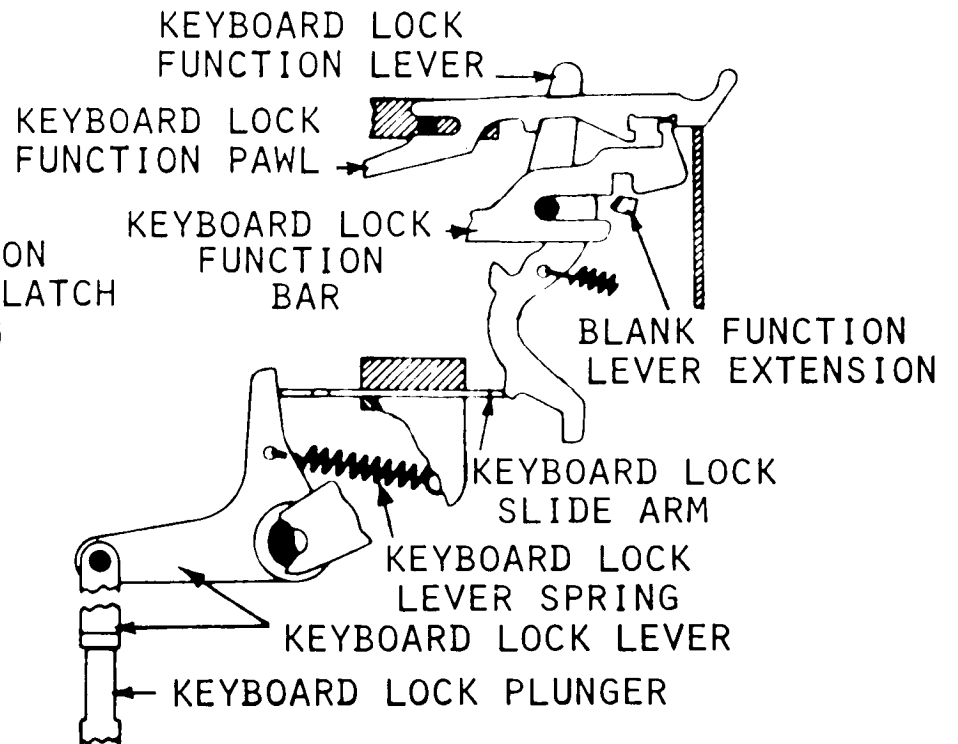

MOD 28 ASR-AN/UGC-6K- REMOTE KEYBOARD LOCK FUNCTION (RIGHT VIEW)

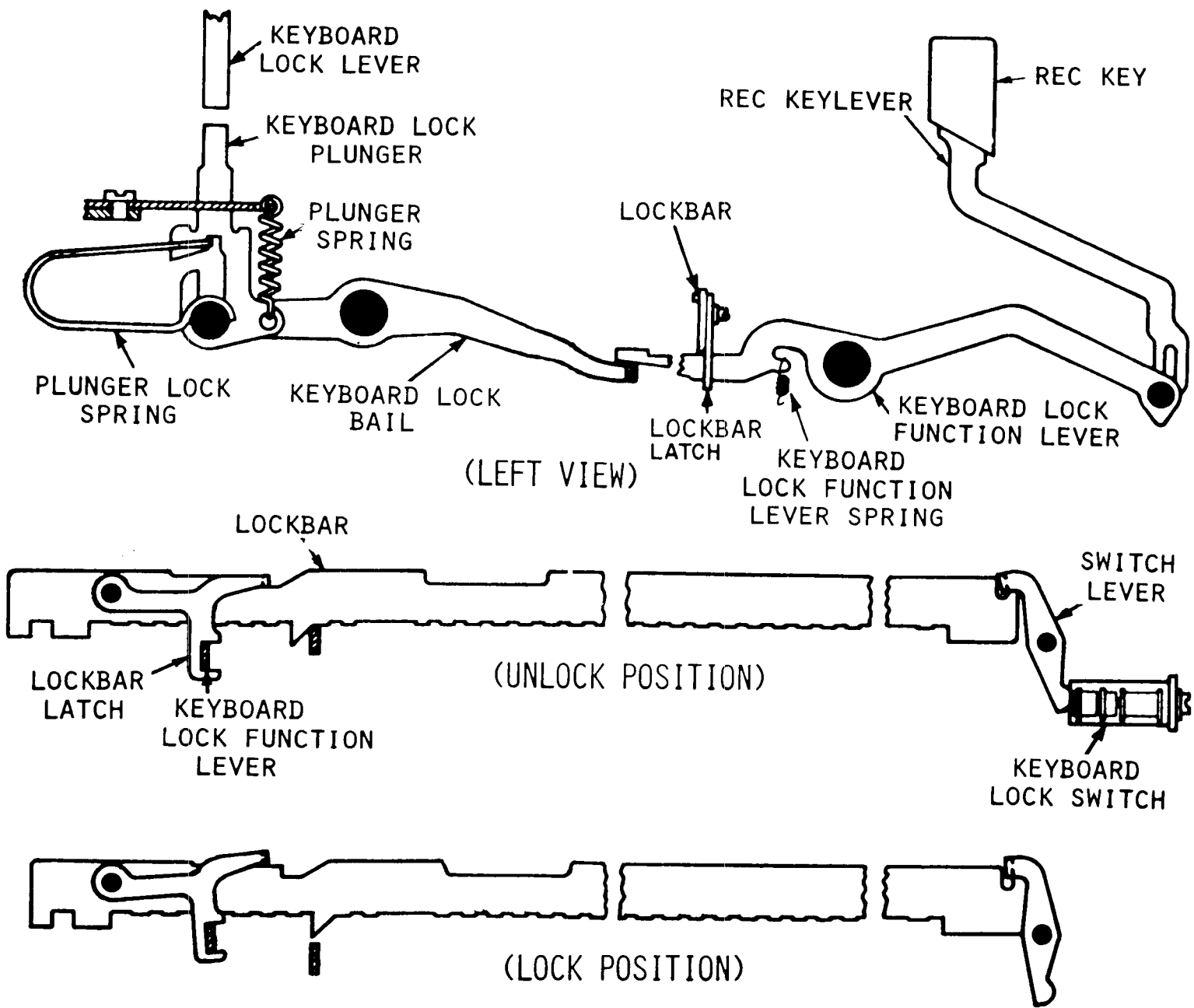

MOD 28 ASR-AN/UGC-6K- LOCKBAR MECHANISM

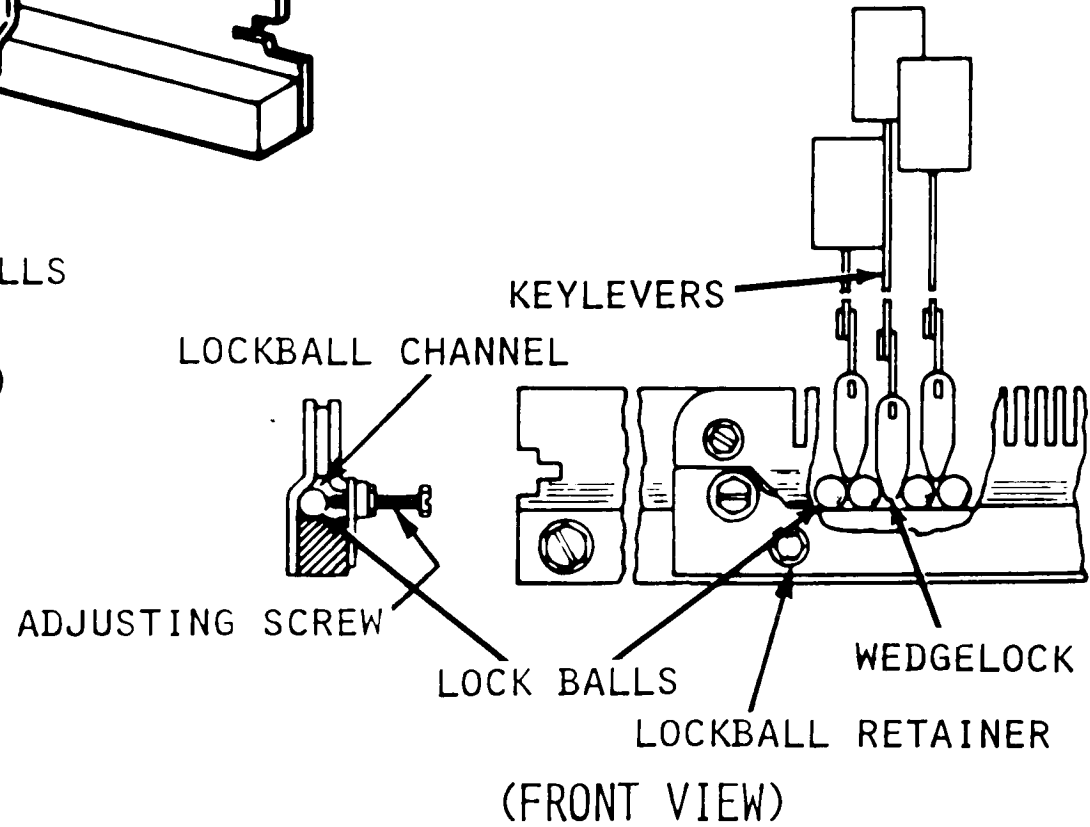
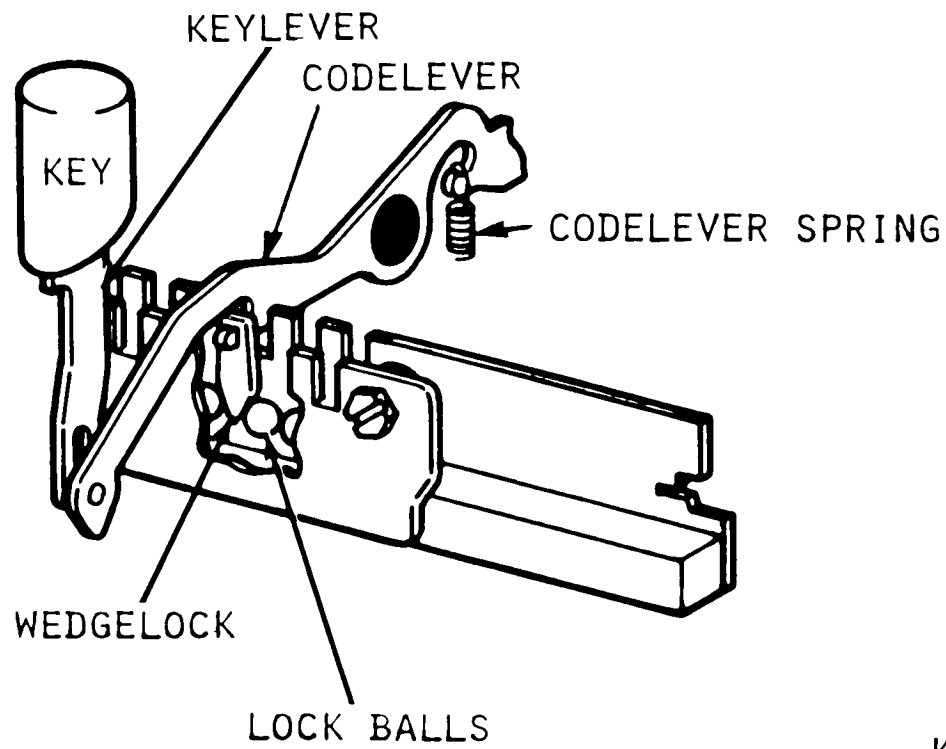

MOD 28 ASR-AN/UGC-6K- LOCKBALL MECHANISM

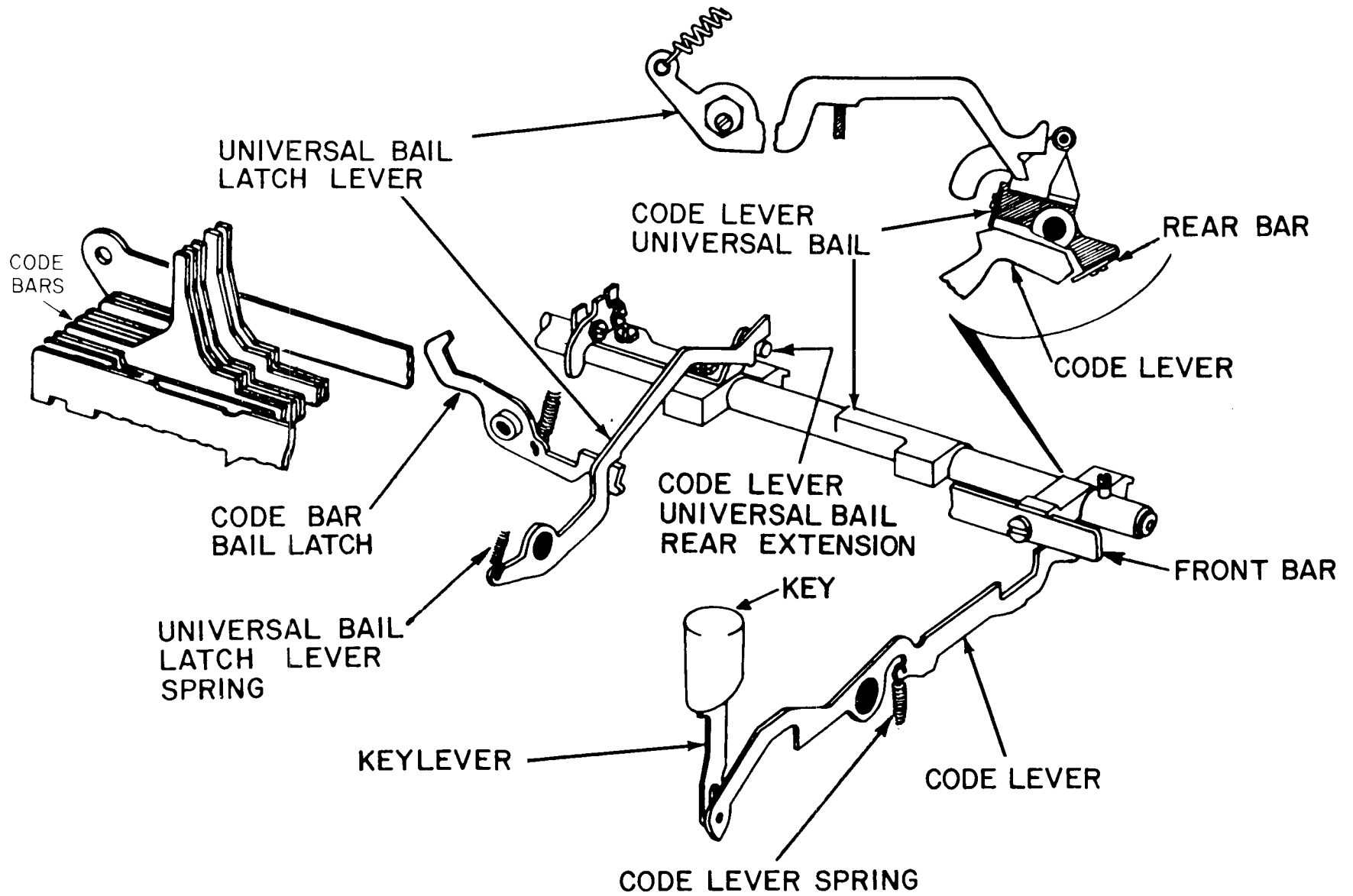

MOD 28 ASR-AN/UGC-6K KEYBOARD MECHANISM No.1 (RIGHT FRONT VIEW)

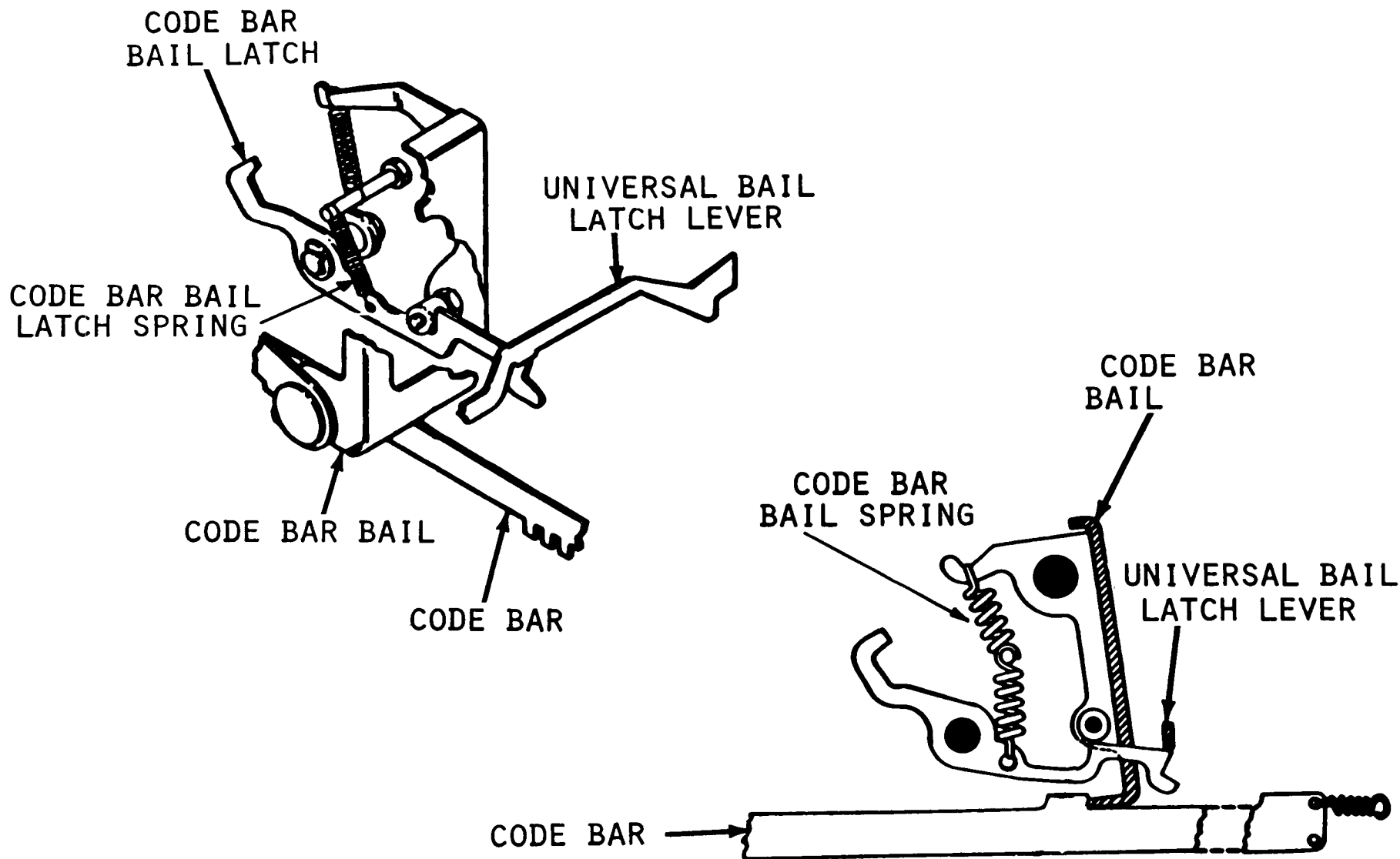

MOD 28 ASR-AN/UGC-6K- KEYBOARD MECHANISM #2

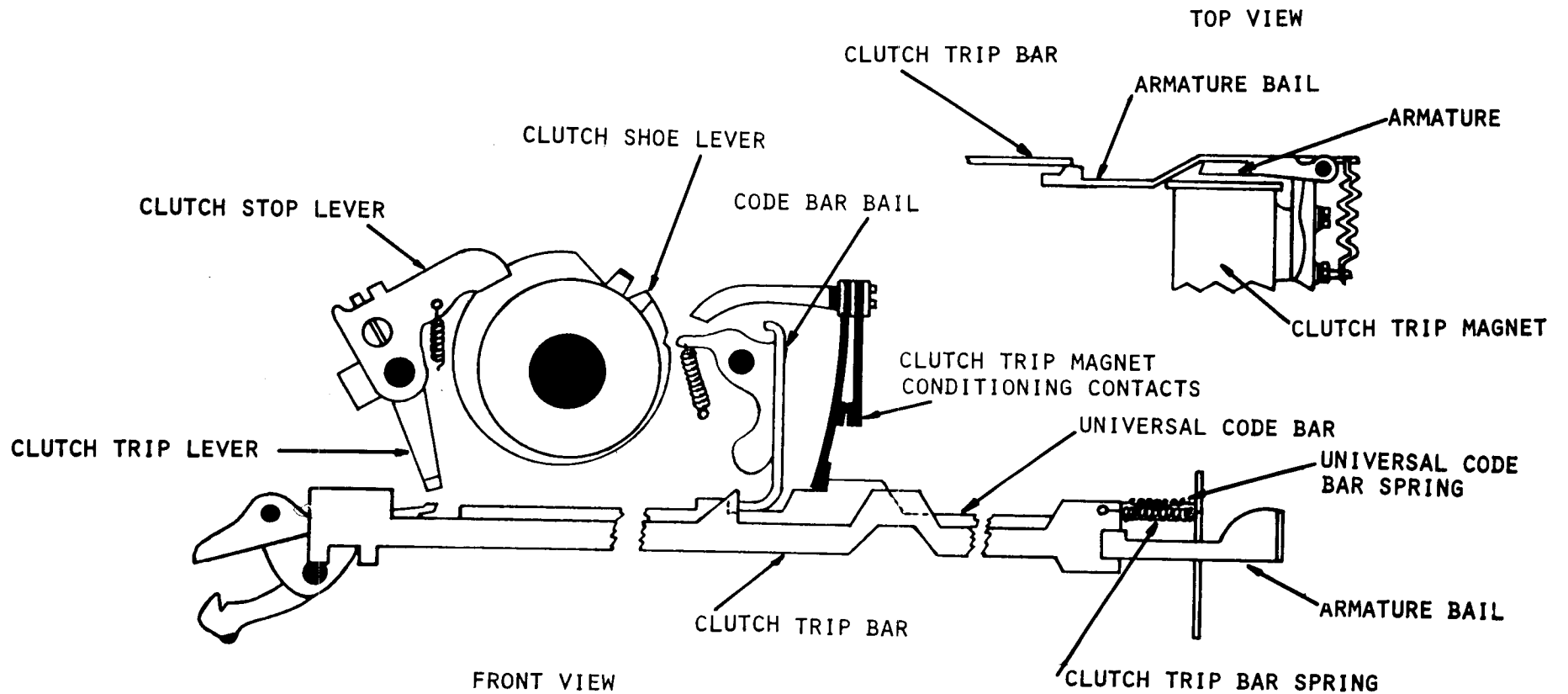

MOD 28 ASR-AN/UGC-6K SIGNAL GENERATOR CLUTCH TRIP

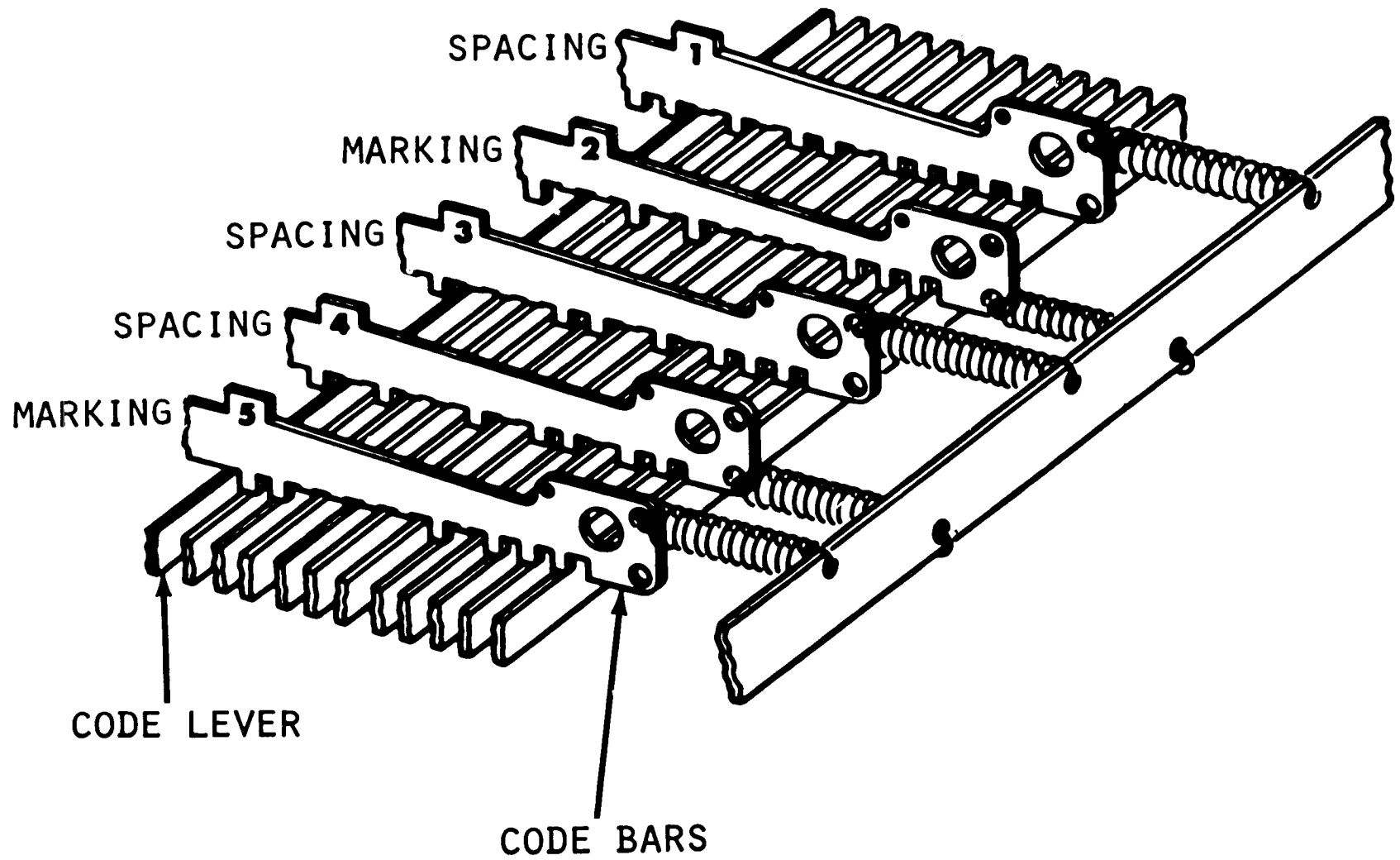

89

MOD 28 ASR-AN/UGC-6K- CODE BAR SELECTION (RIGHT FRONT VIEW)

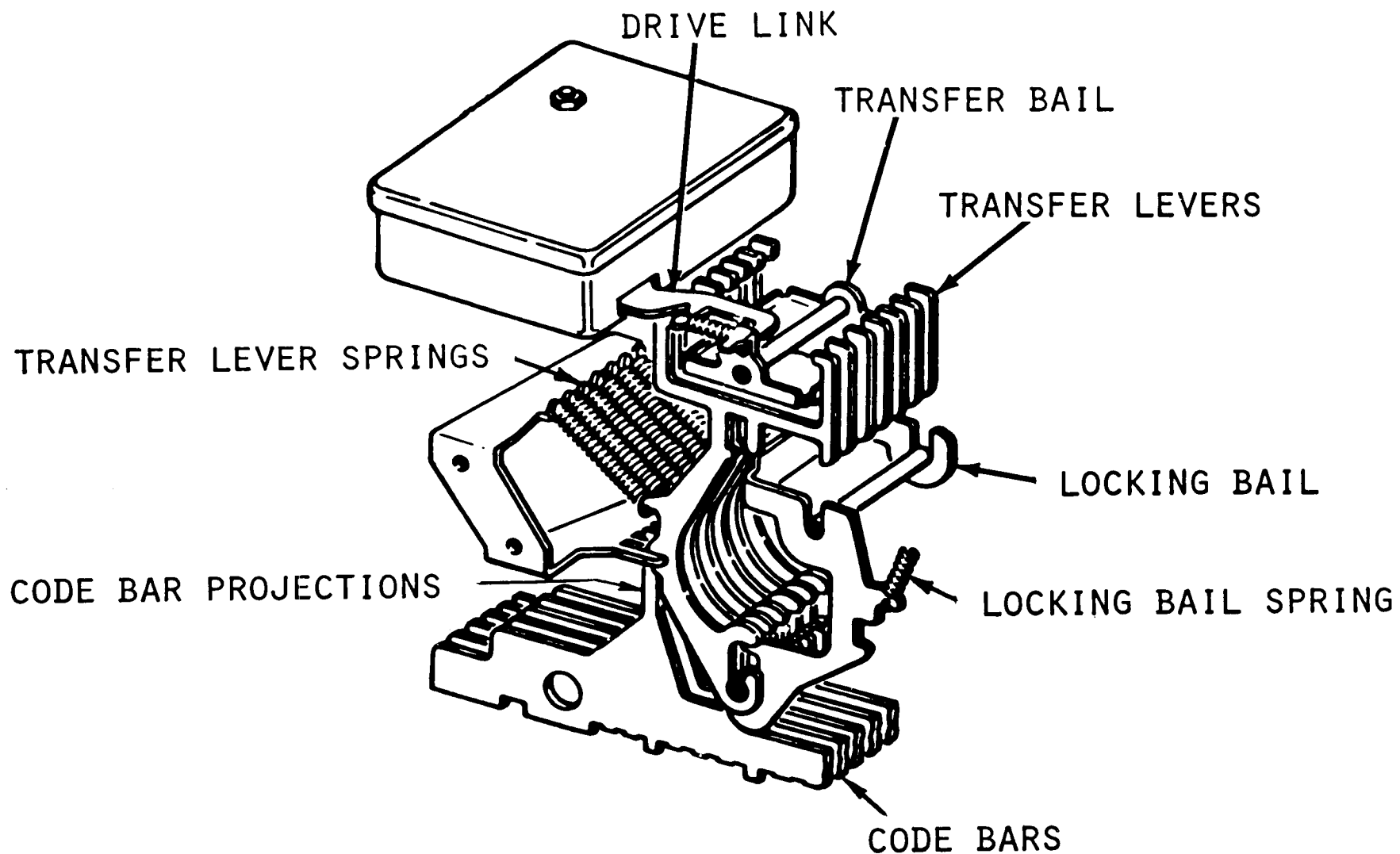

MOD 28 ASR-AN/UGC-6K- TRANSFER LEVER MECHANISM

TRANSFER LEVERS

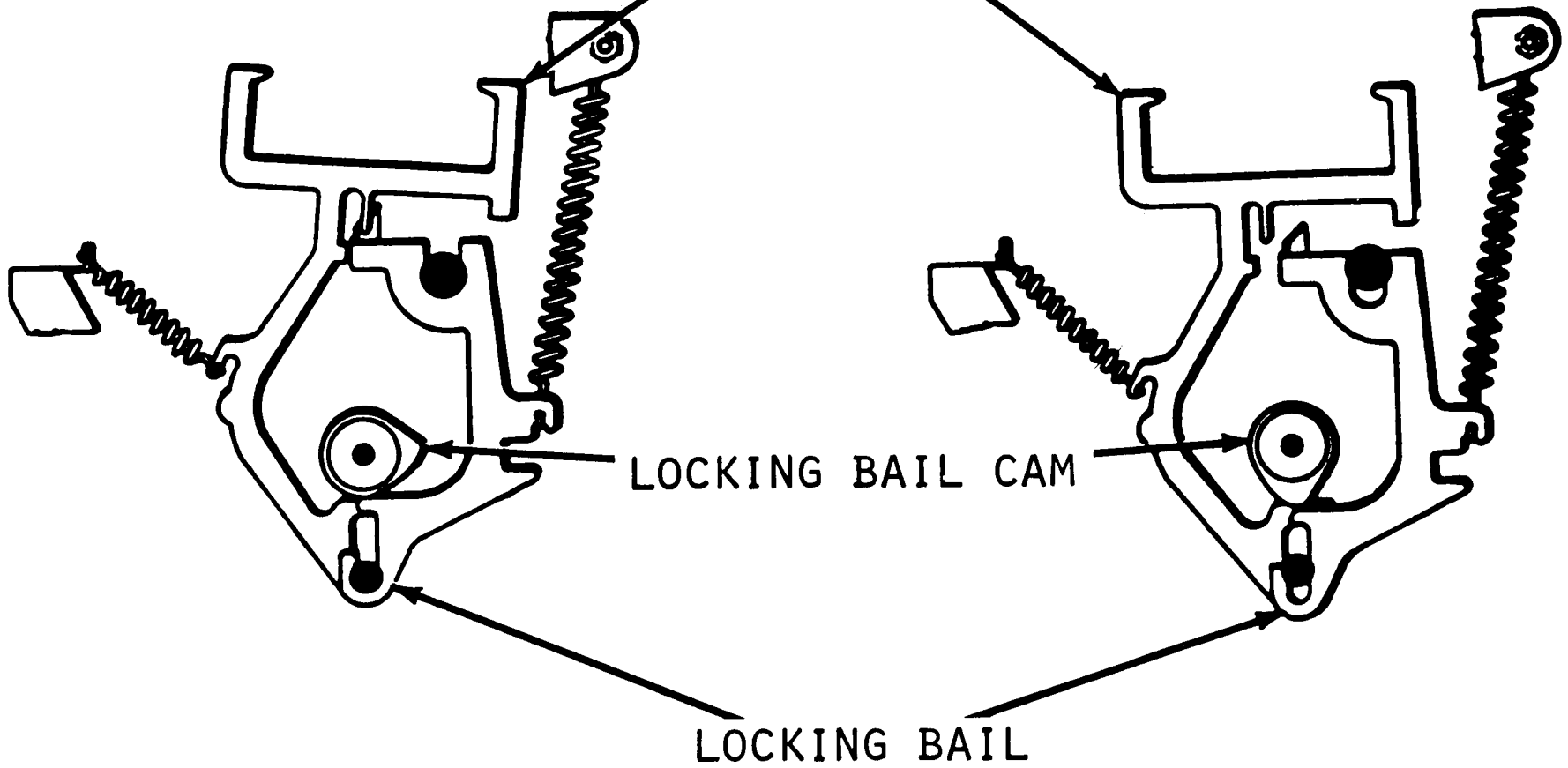

LOCKING BAIL CAM

LOCKING BAIL

MOD 28 ASR-AN/UGC-6K- LOCKING BAIL

3-1-7D

70

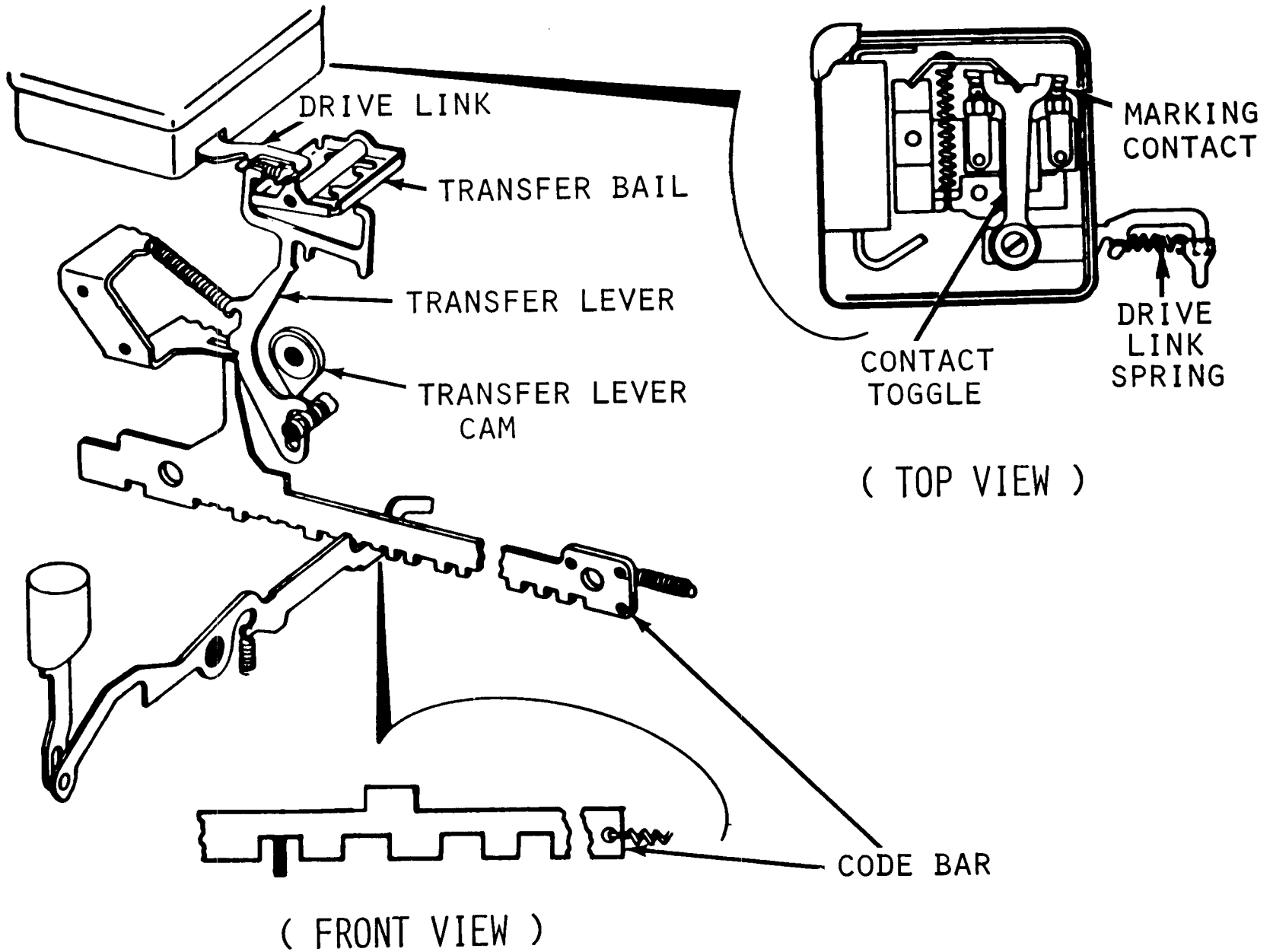

MOD 28 ASR-AN/UGC-6K- SIGNAL CONTACT BOX (MARKING)

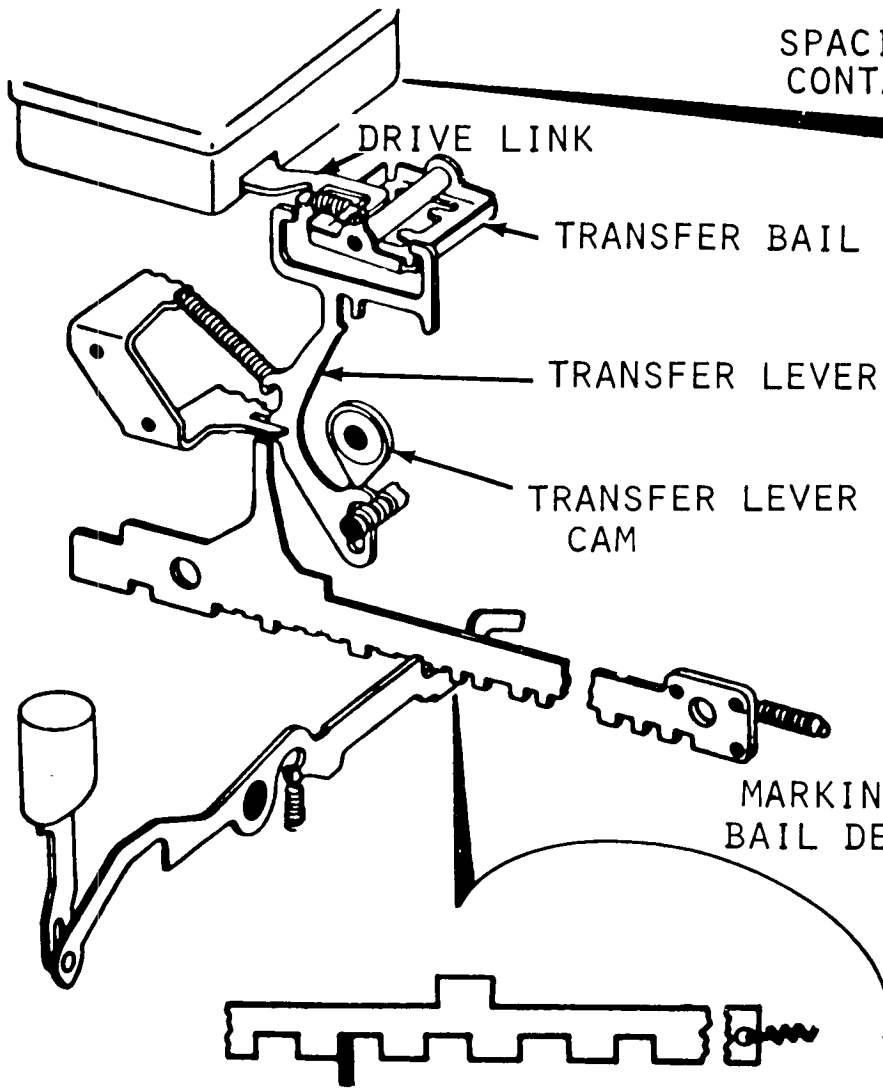

(FRONT VIEW)

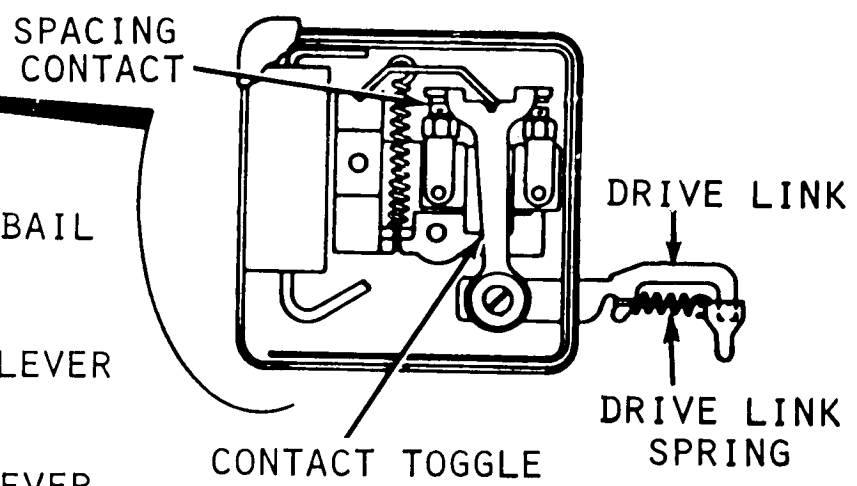

(TOP VIEW)

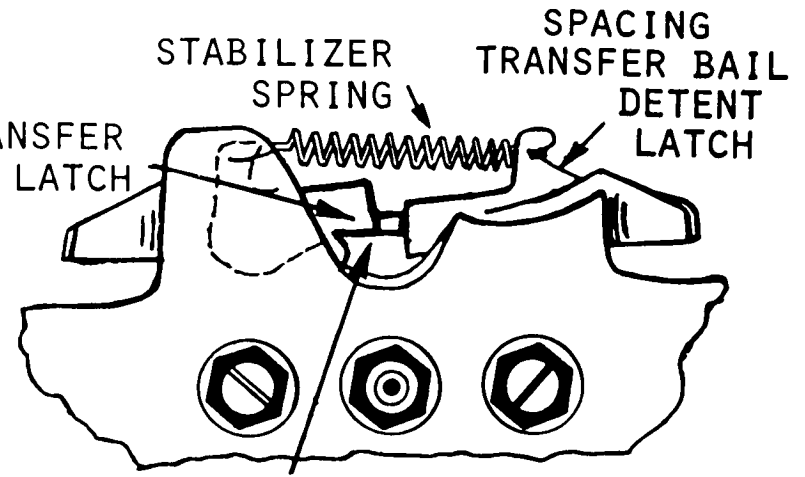

(MARKING CONDITION)

MOD 28 ASR-AN/UGC-6K- SIGNAL CONTACT BOX (SPACING)

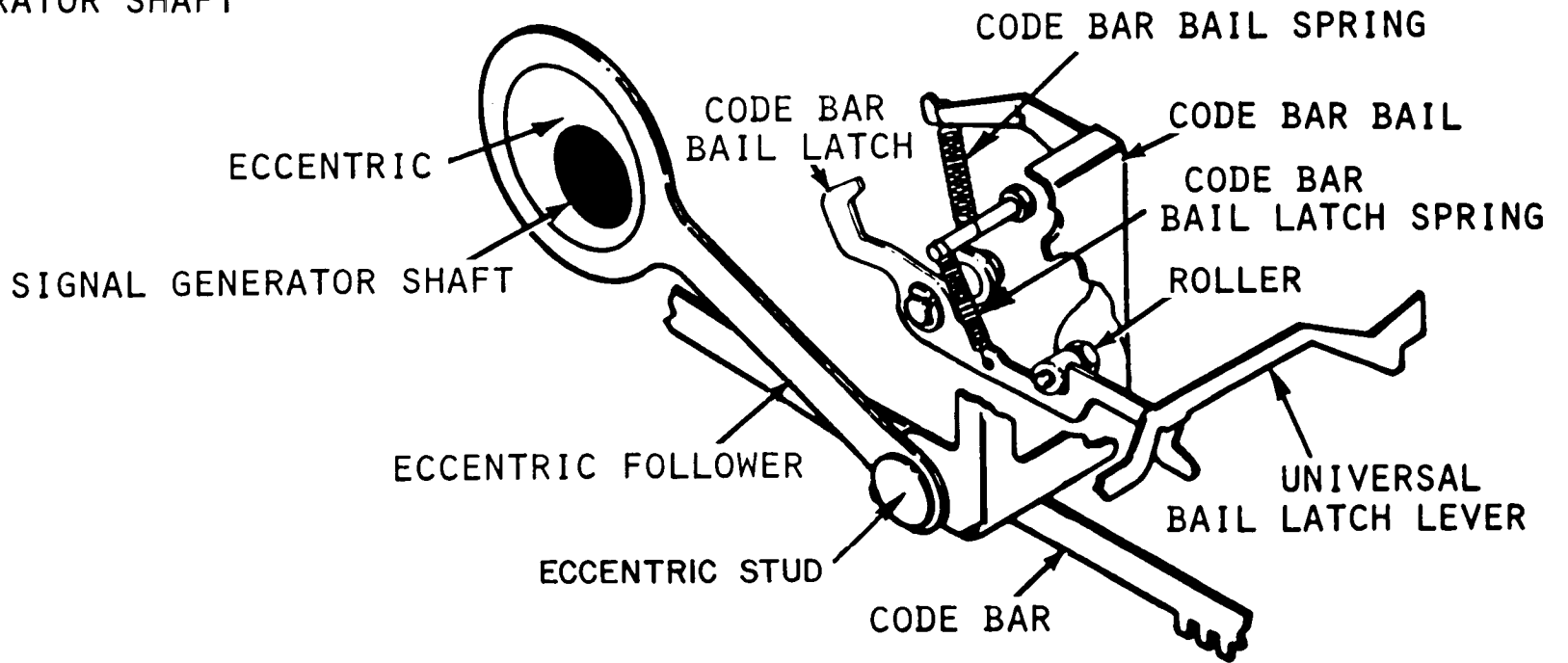
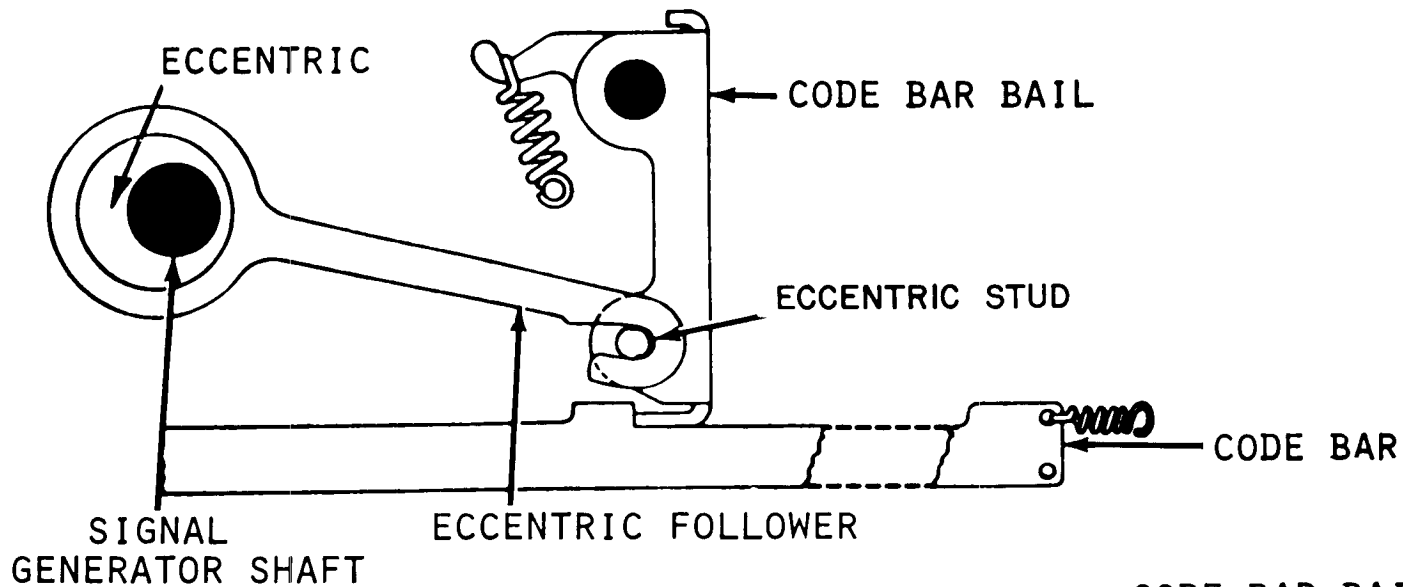

MOD 28 ASR-AN/UGC- KEYBOARD RESET #1

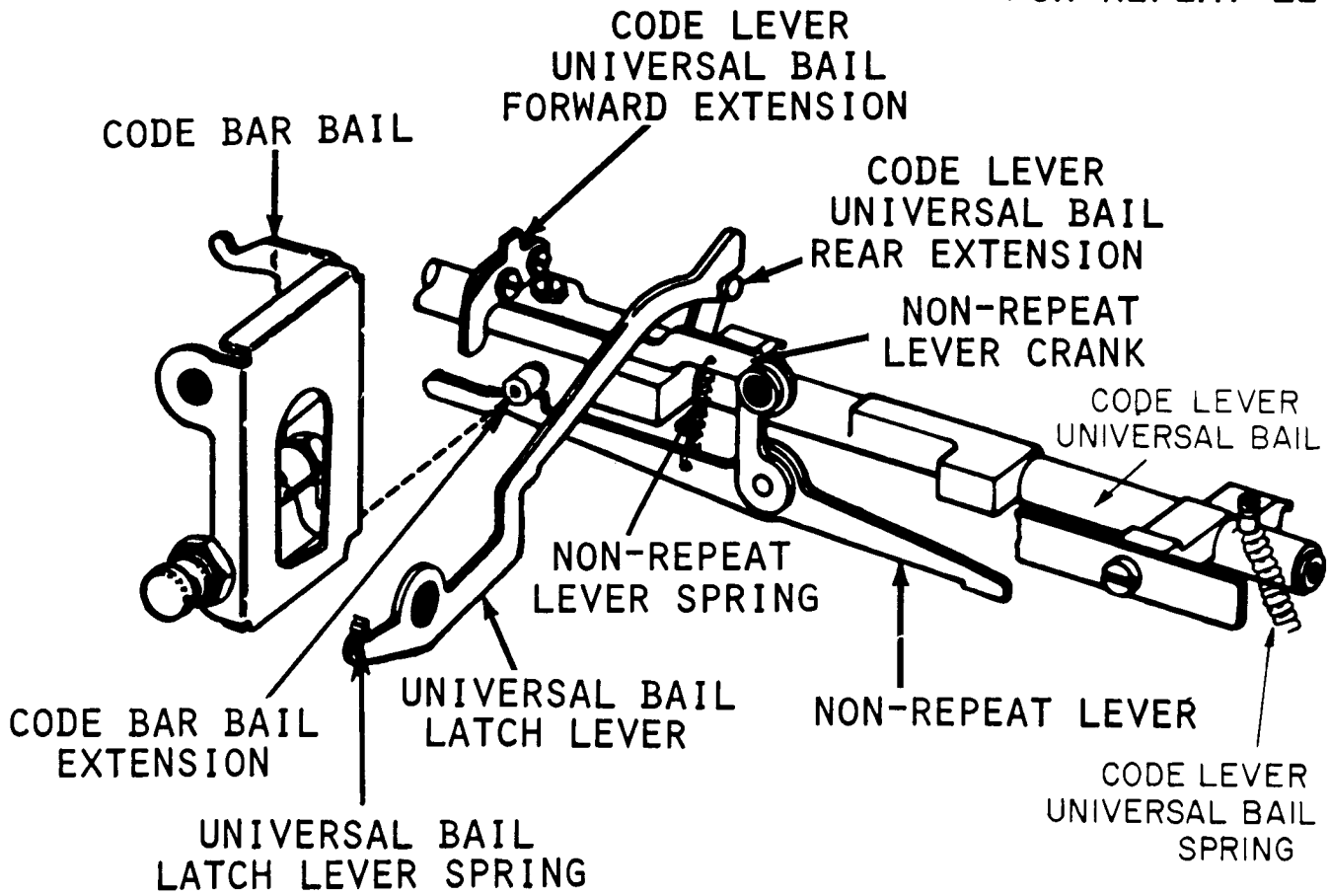
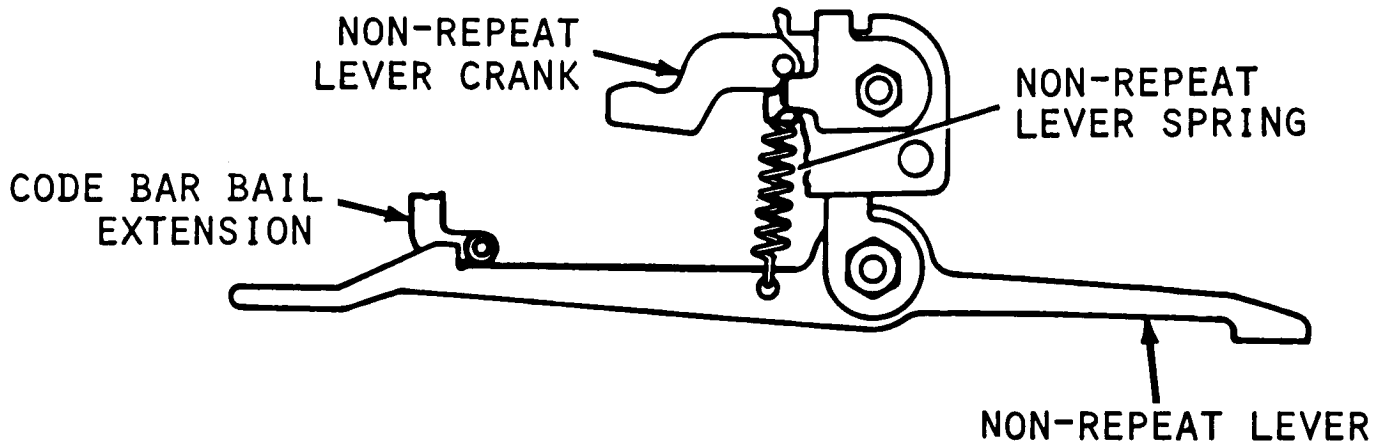

MOD 28 ASR-AN/UGC-6K- KEYBOARD RESET #2

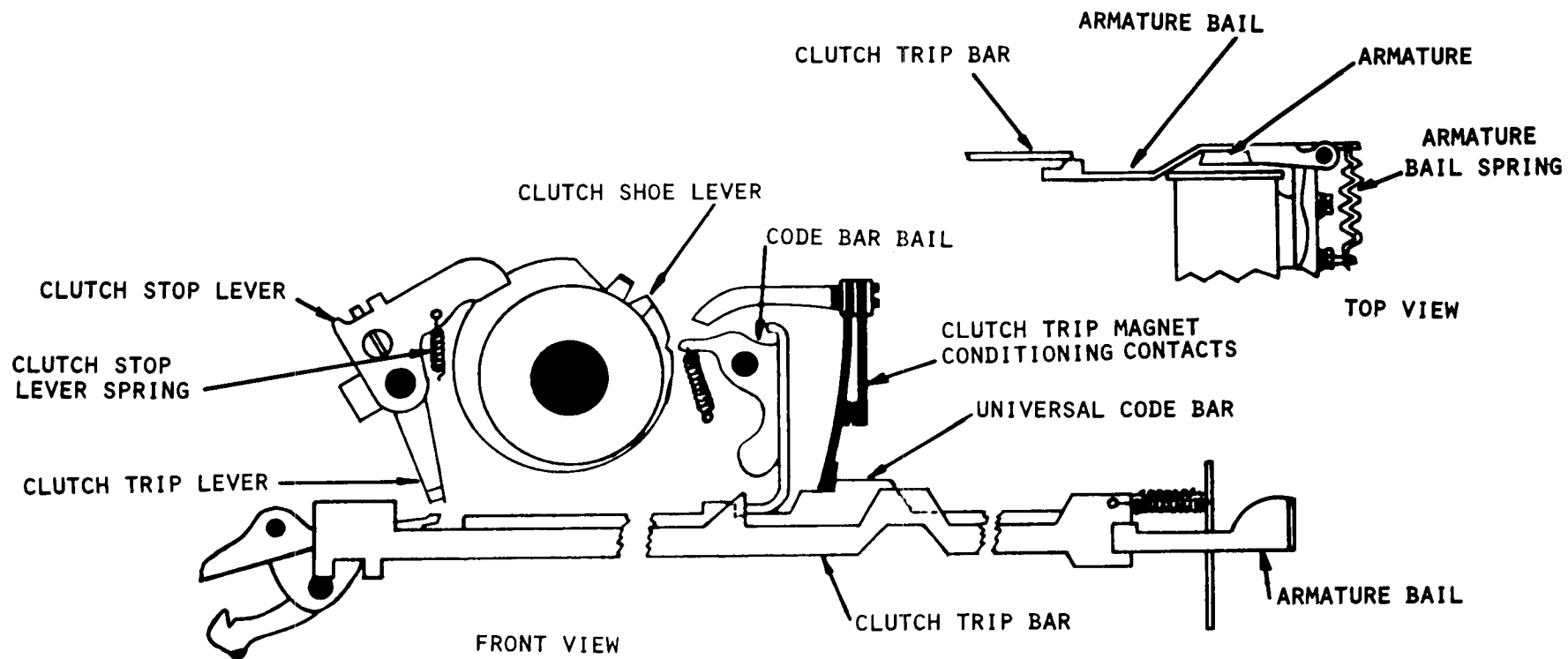

MOD 28 ASR-AN/UGC-6K DISENGAGING SIGNAL GENERATOR CLUTCH

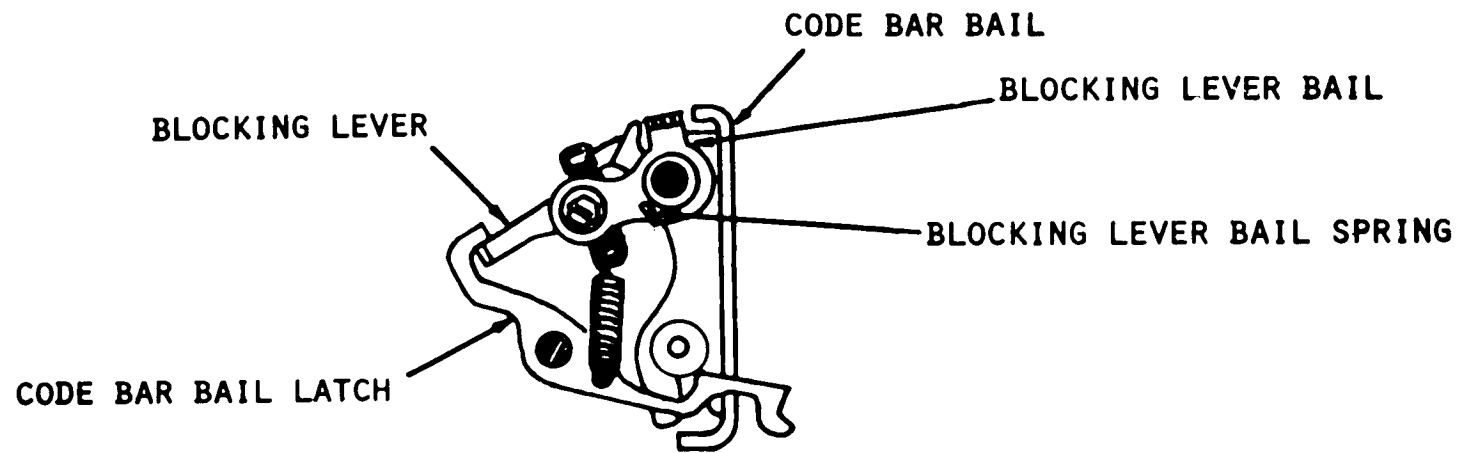

76

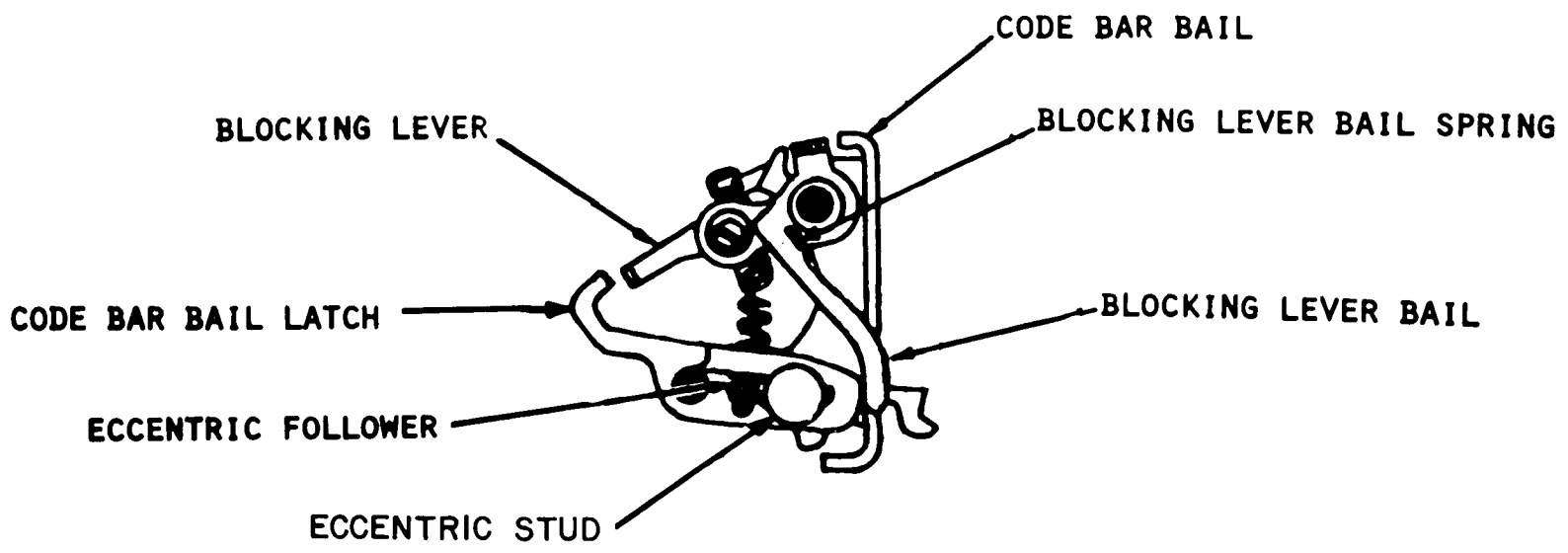

MOD 28 ASR-AN/UGC-6K CLUTCH TRIP DELAY

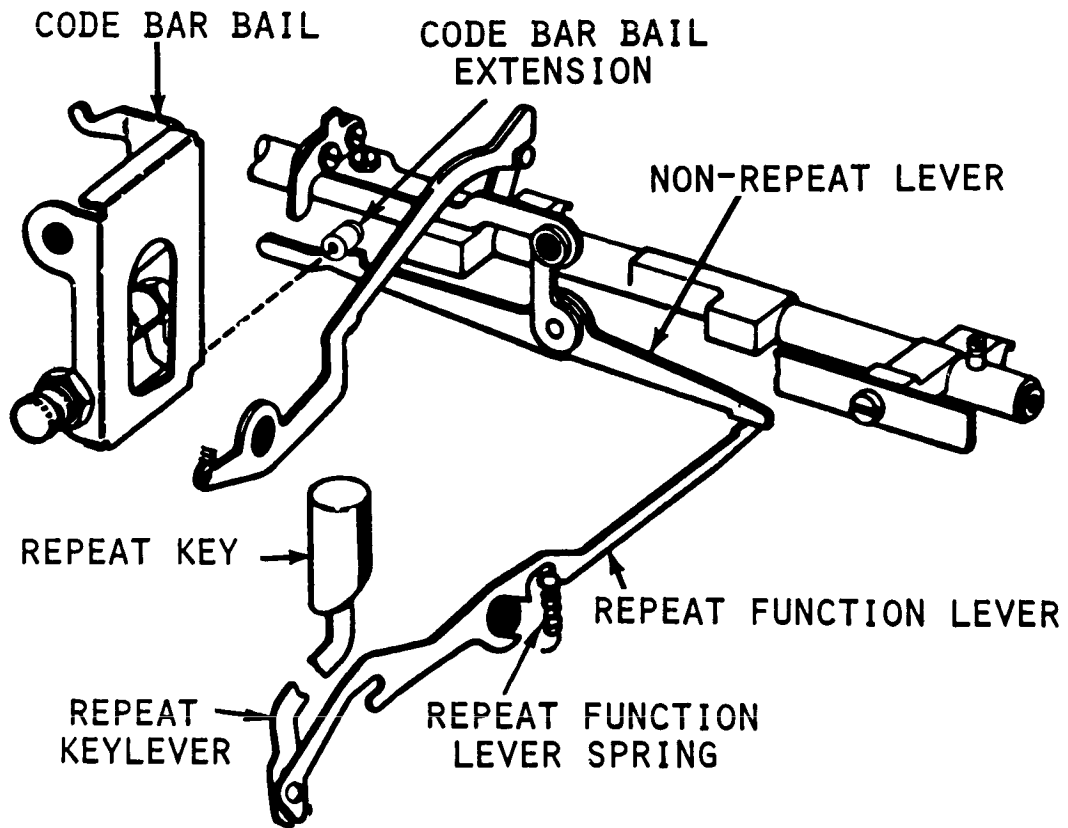
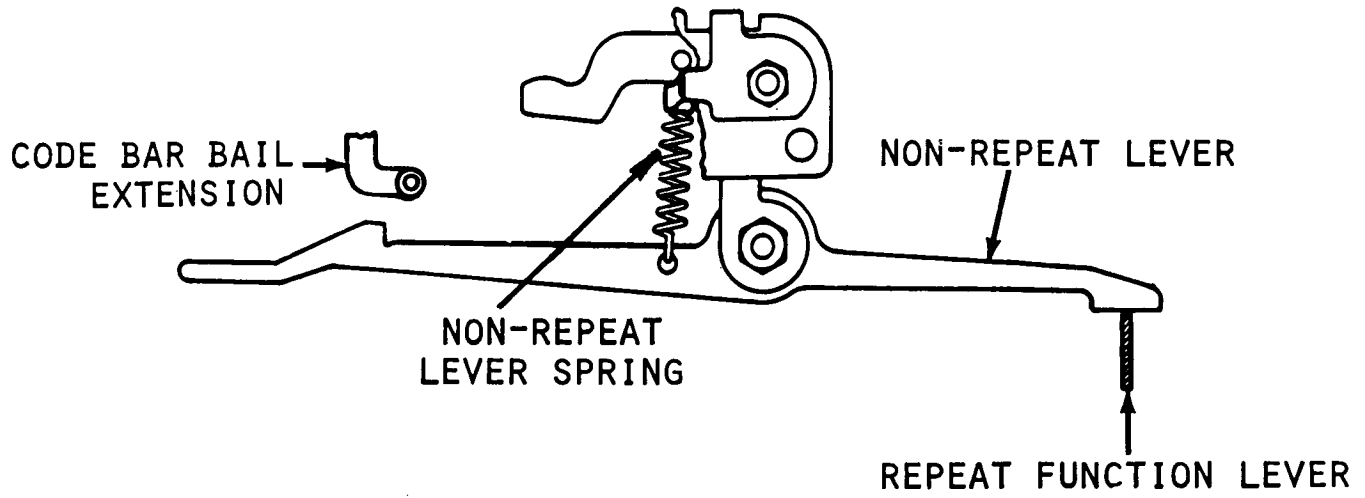

MOD 28 ASR-AN/UGC-6K- REPEAT KEY OPERATION

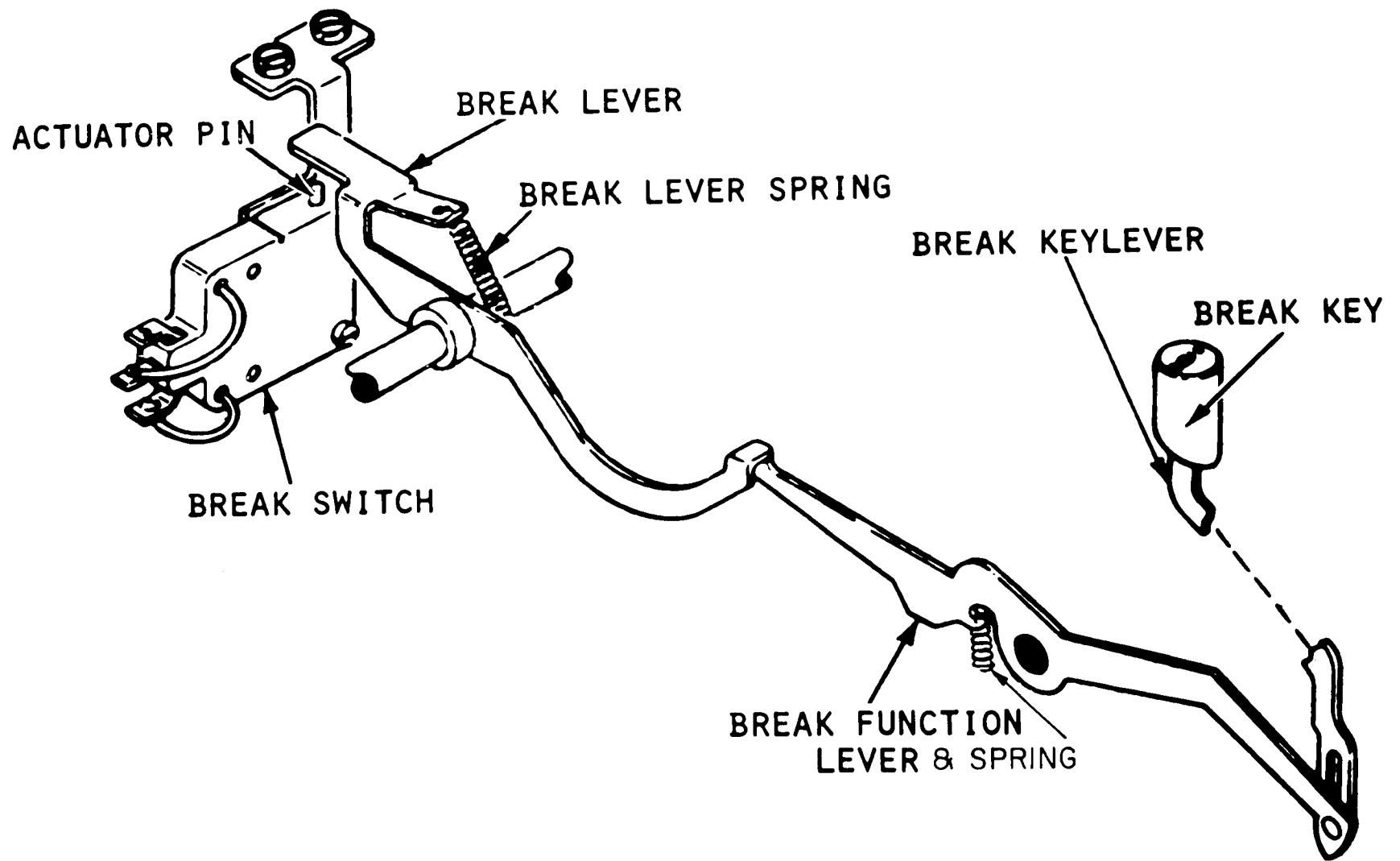

78

MOD 28 ASR-AN/UGC-6K- LINE BREAK MECHANISM

3-1-15D

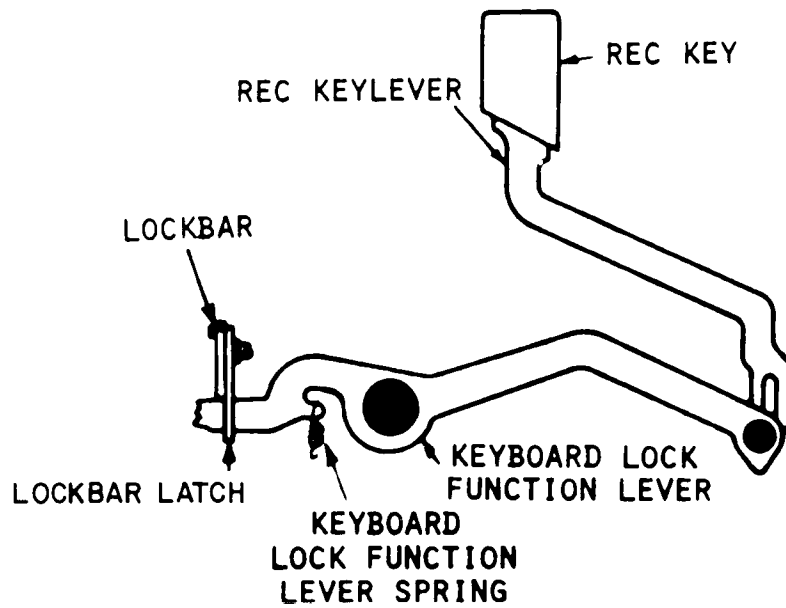

(LEFT VIEW)

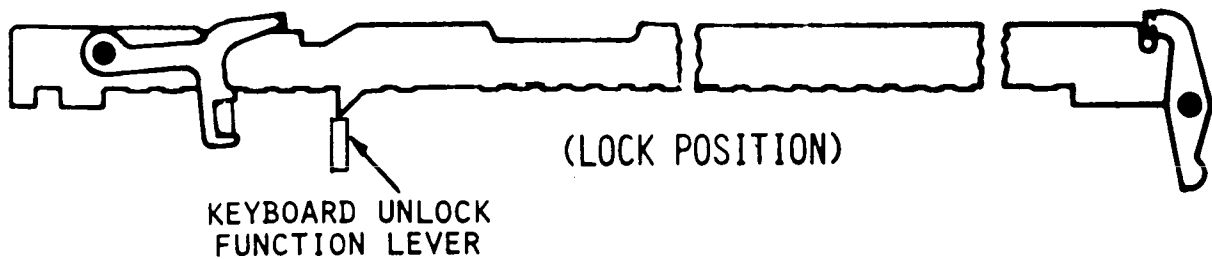
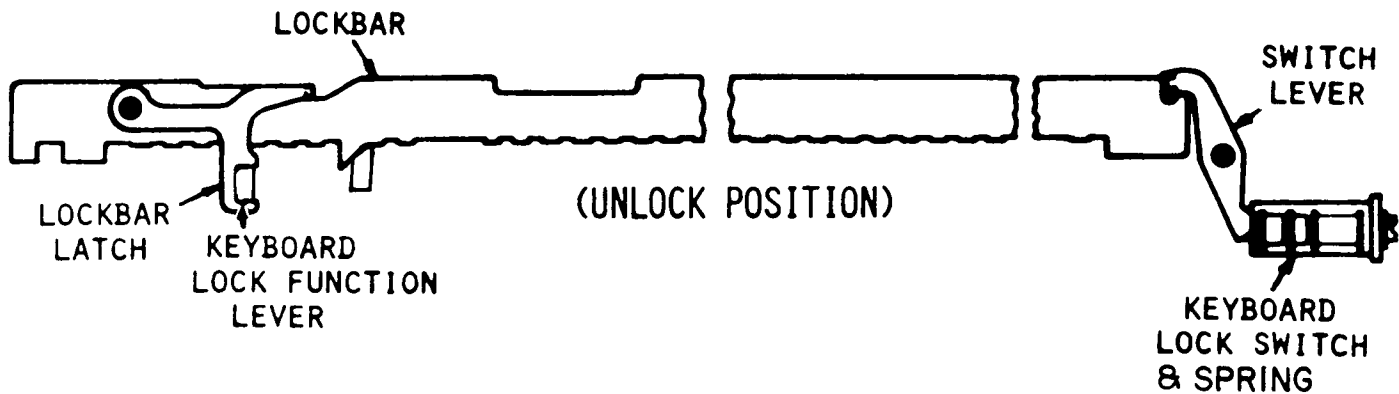

(FRONT VIEW)

MOD 28 ASR-AN/UGC-6K- LOCAL KEYBOARD LOCK

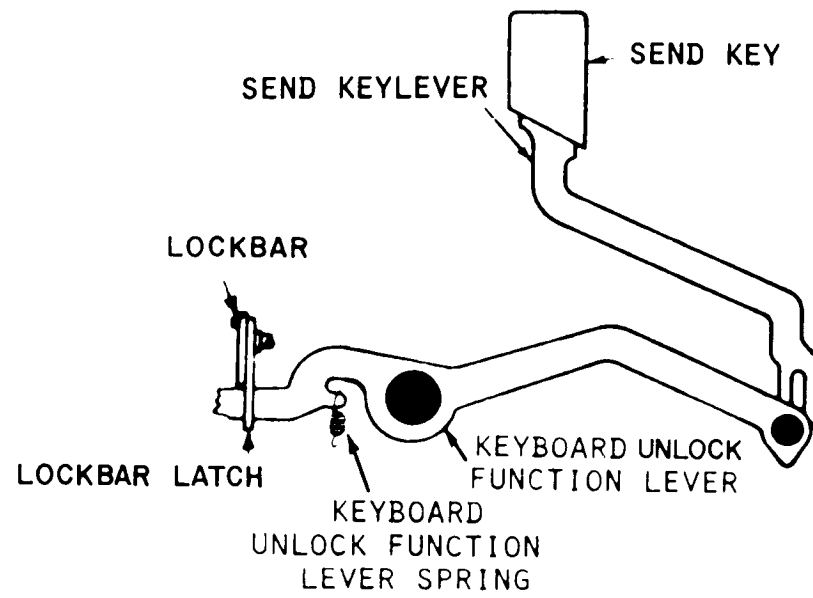

(LEFT VIEW)

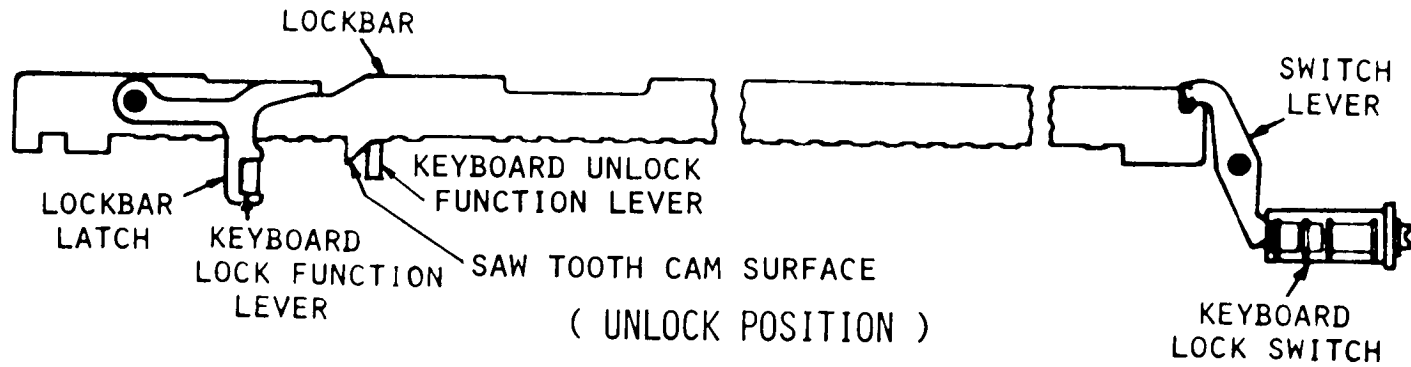

(UNLOCK POSITION)

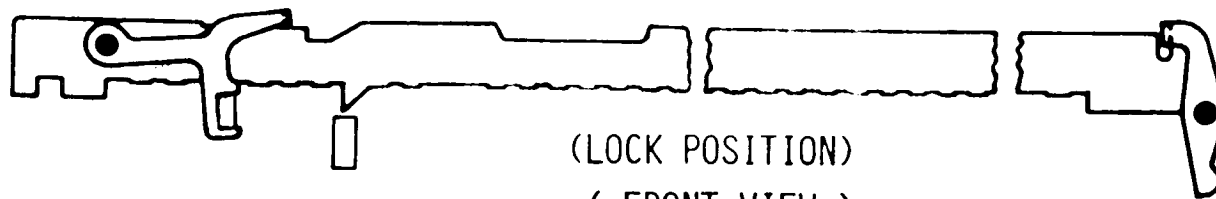

(LOCK POSITION)
(FRONT VIEW)

MOD 28 ASR-AN/UGC-6K- KEYBOARD UNLOCK

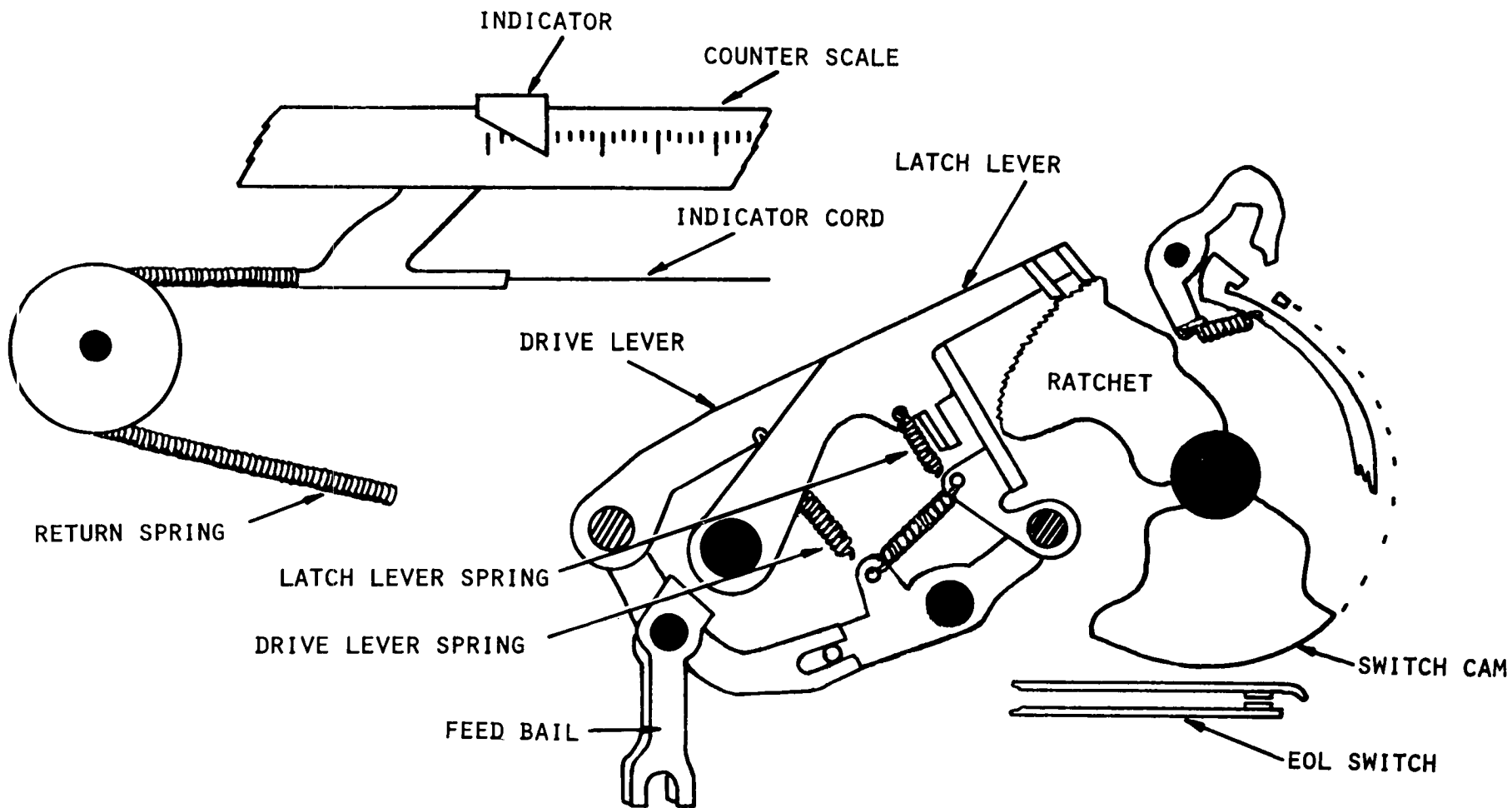

MOD 28 ASR-AN/UGC-6K CHARACTER COUNTER (COUNTING)

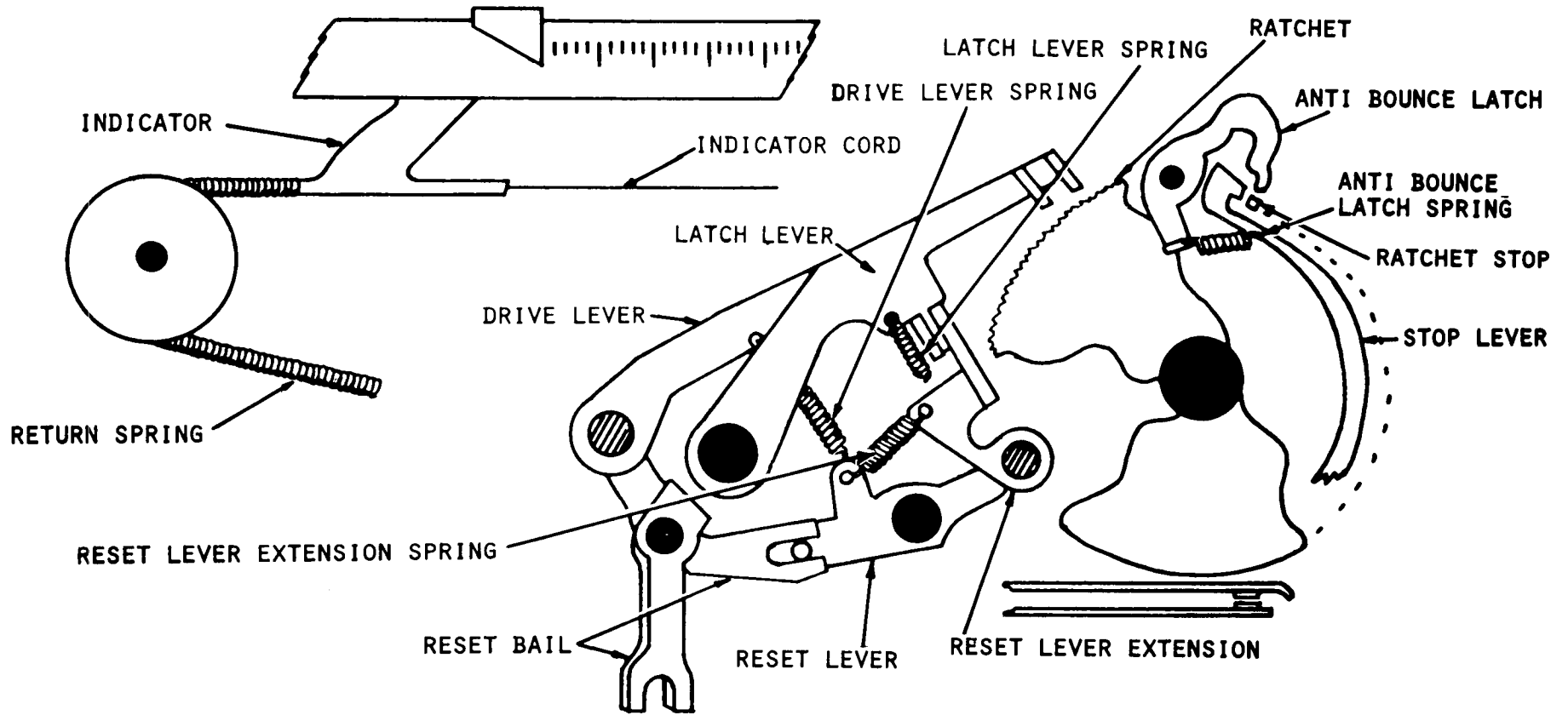

MOD 28 ASR-AN/UGC-6K CHARACTER COUNTER (RESETTING)

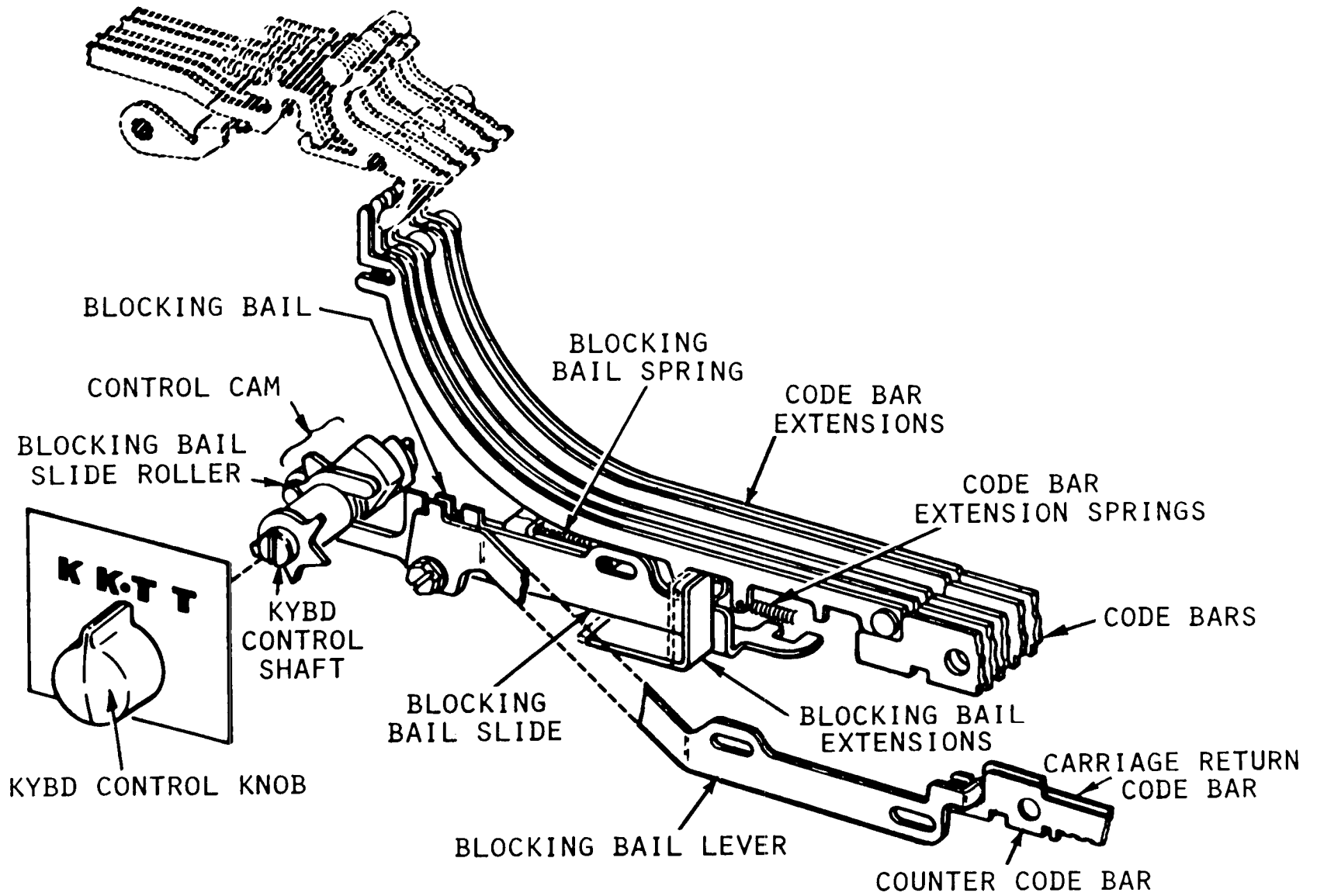

MOD 28 ASR-AN/UGC-6K- BLOCKING BAIL OPERATION

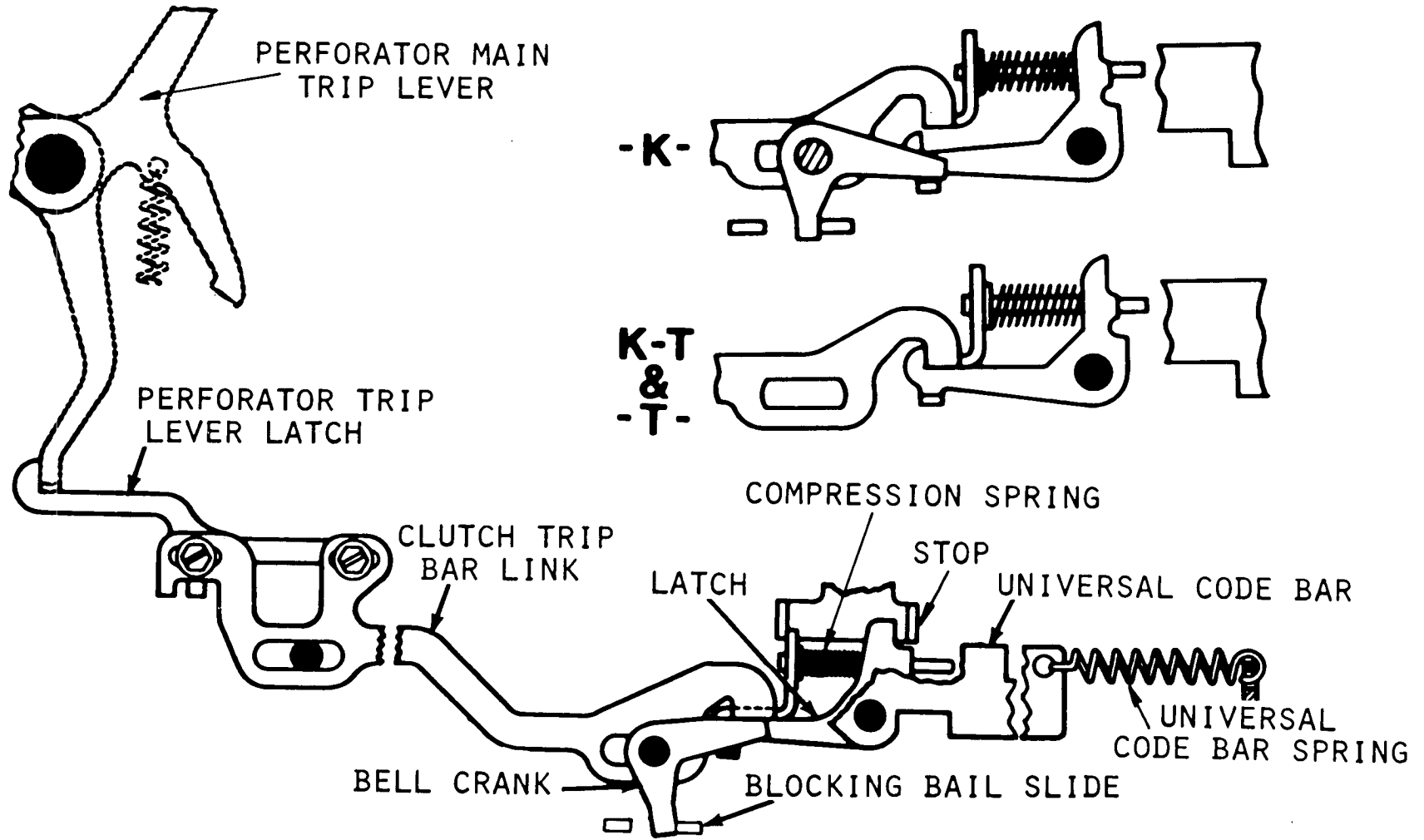

MOD 28 ASR-AN/UGC-6K- BELL CRANK OPERATION

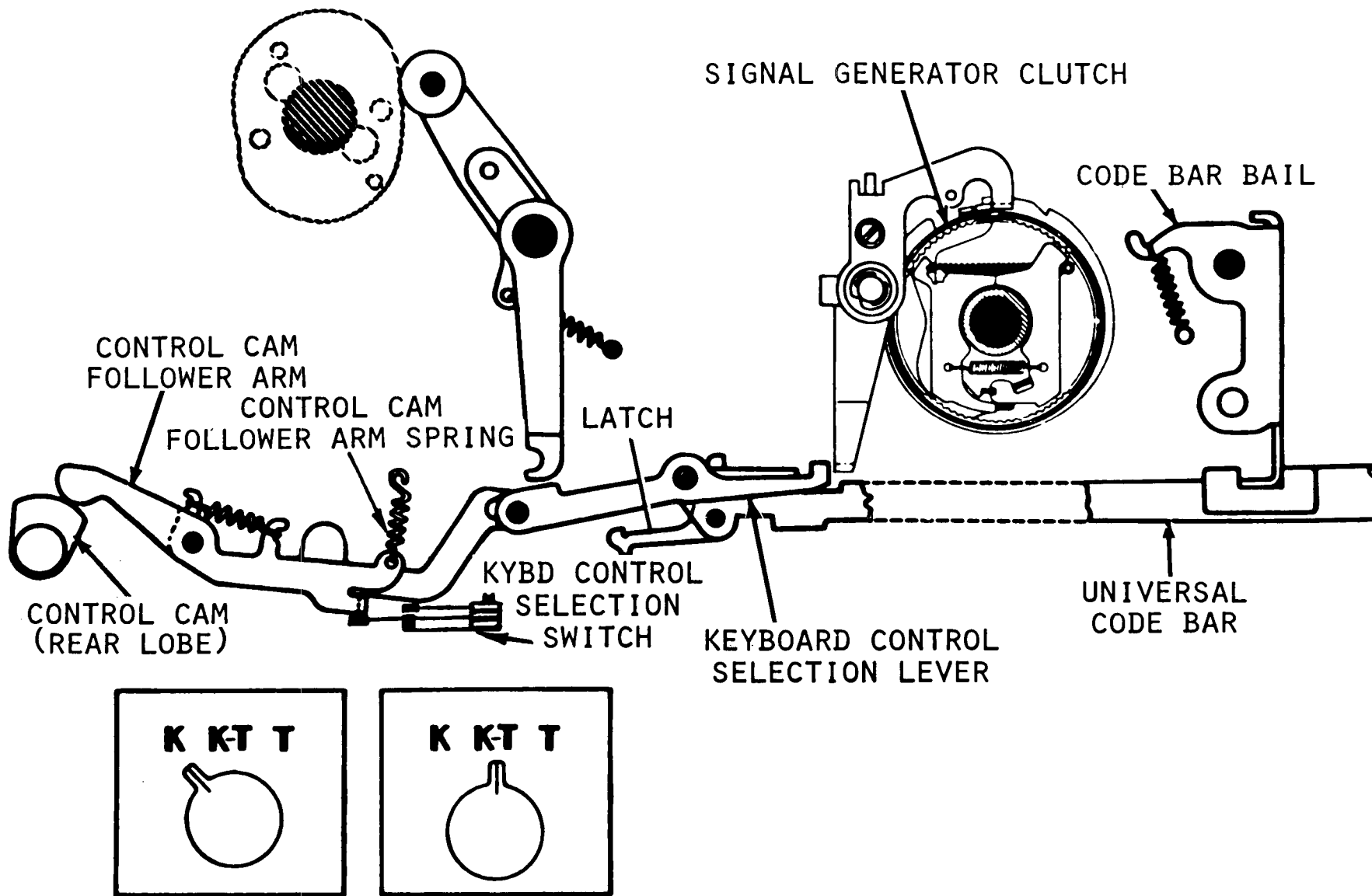

MOD 28 ASR-AN/UGC-6K- KYBD CONTROL SELECTION LEVER (K-KT)

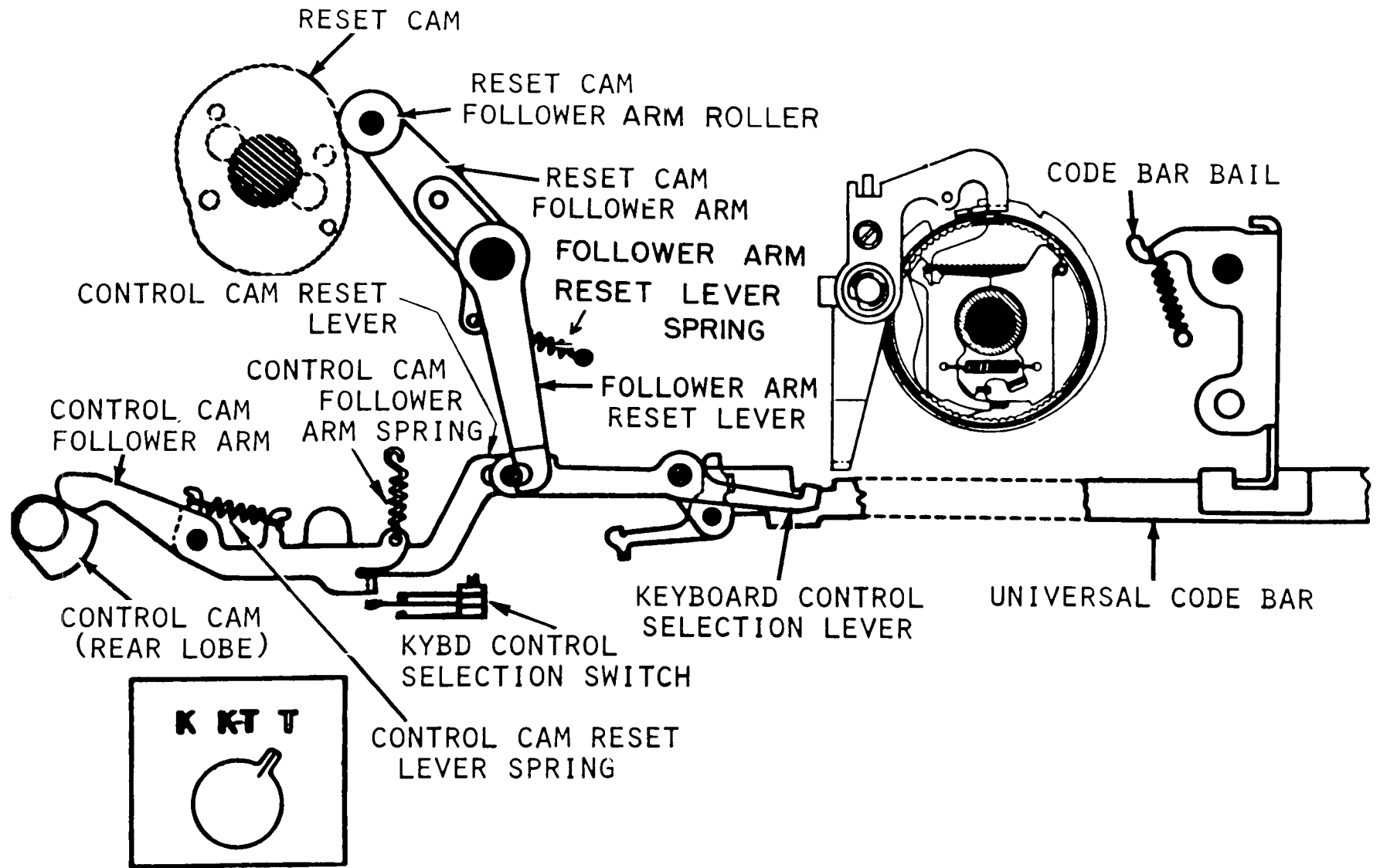

MOD 28 ASR-AN/UGC-6K- KYBD CONTROL SELECTION LEVER (T)

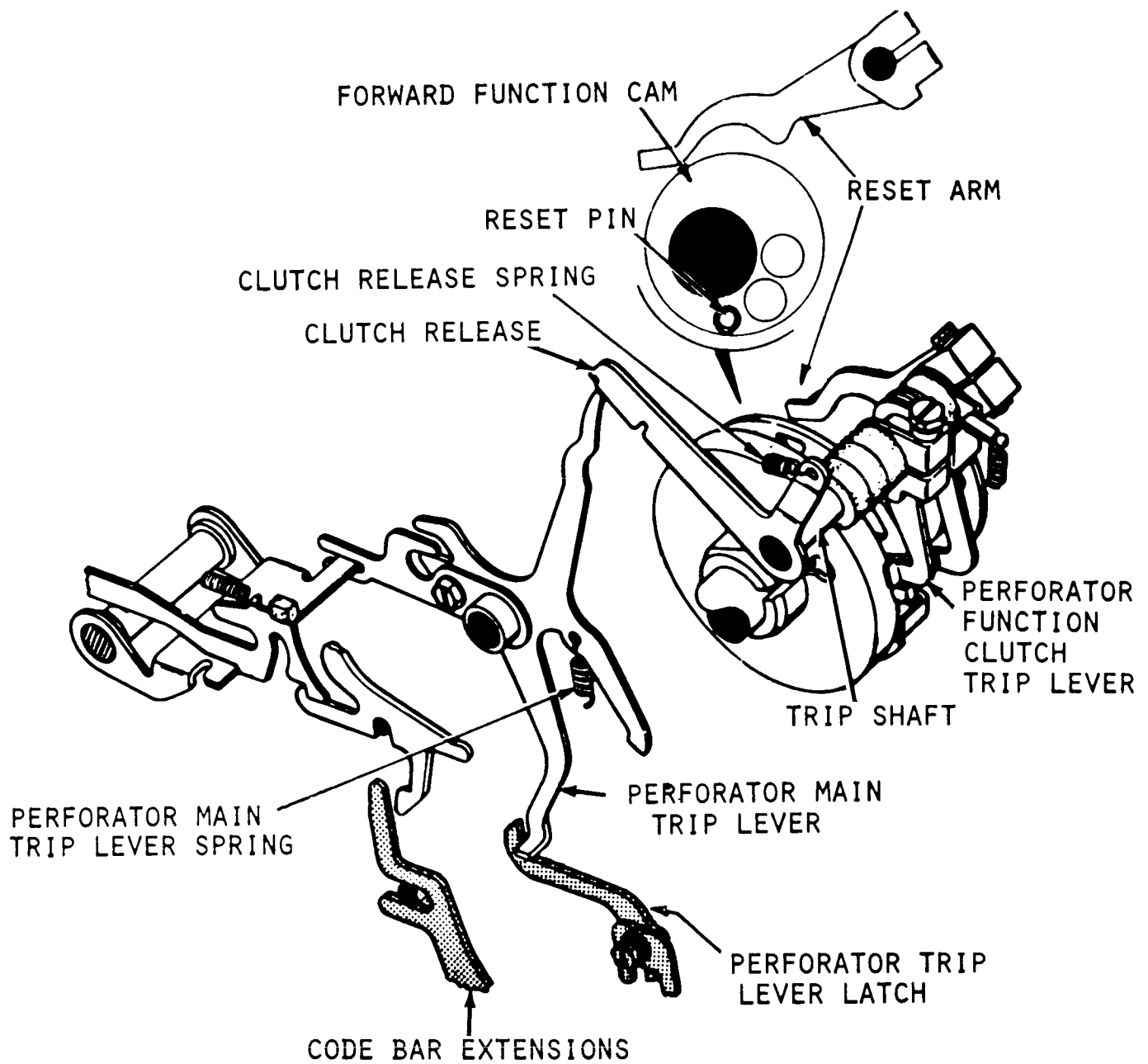

MOD 28 ASR-AN/UGC-6K- PERFORATOR FUNCTION CLUTCH TRIP

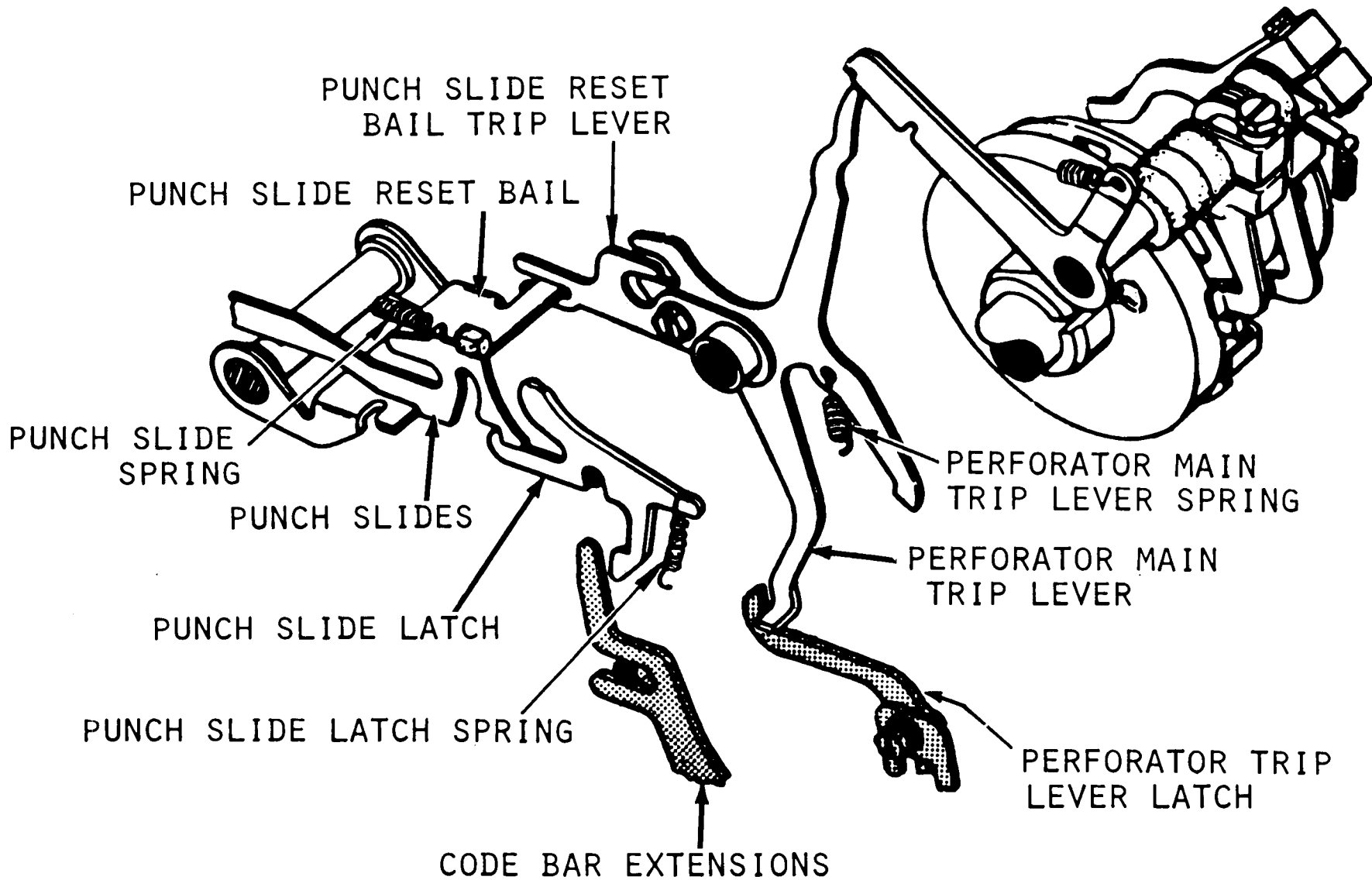

88

MOD 28 ASR-AN/UGC-6K- PUNCH SLIDE RESET BAIL

4-1-6D

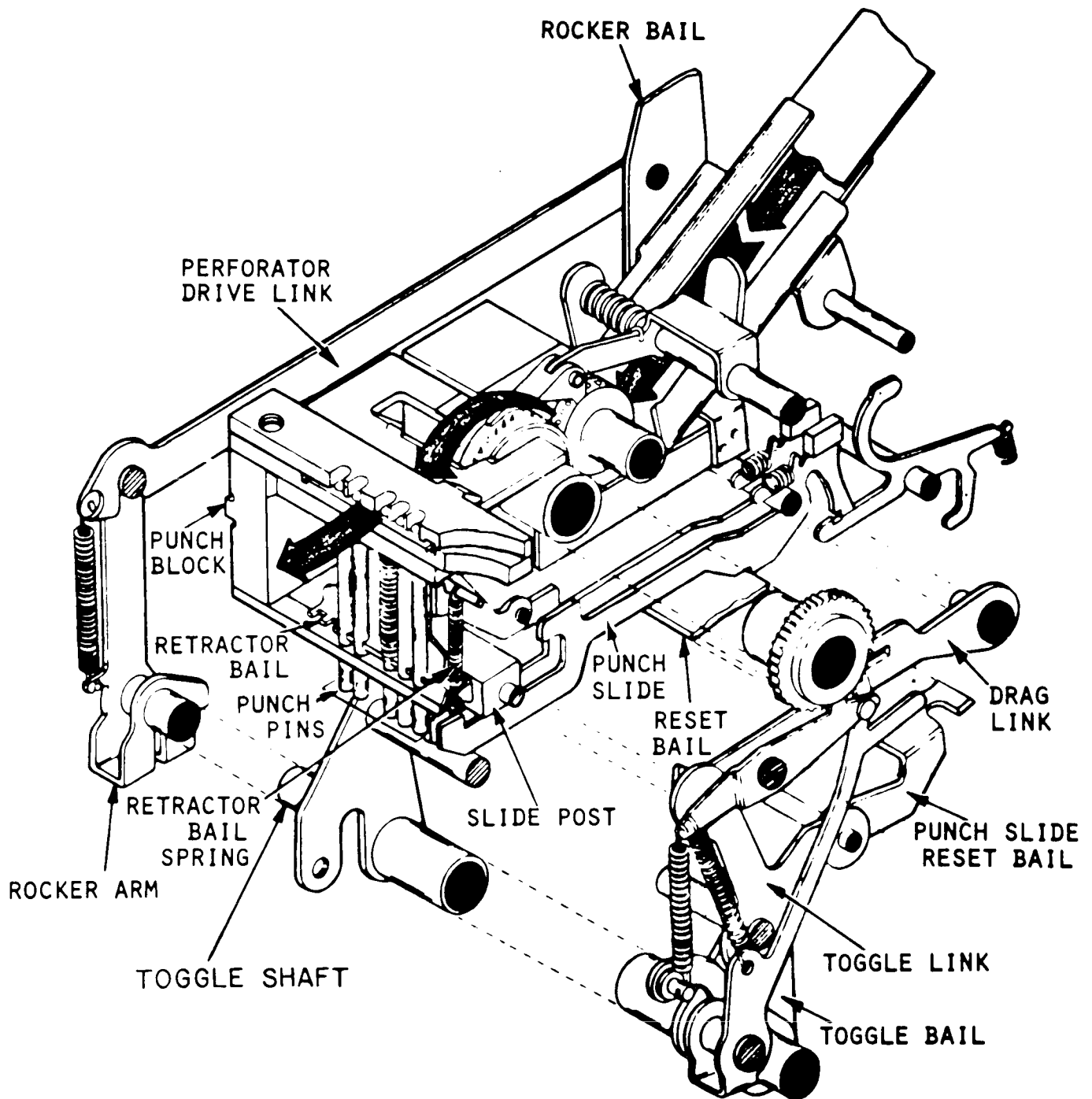

MOD 28 ASR-AN/UGC-6K- PUNCH MECHANISM

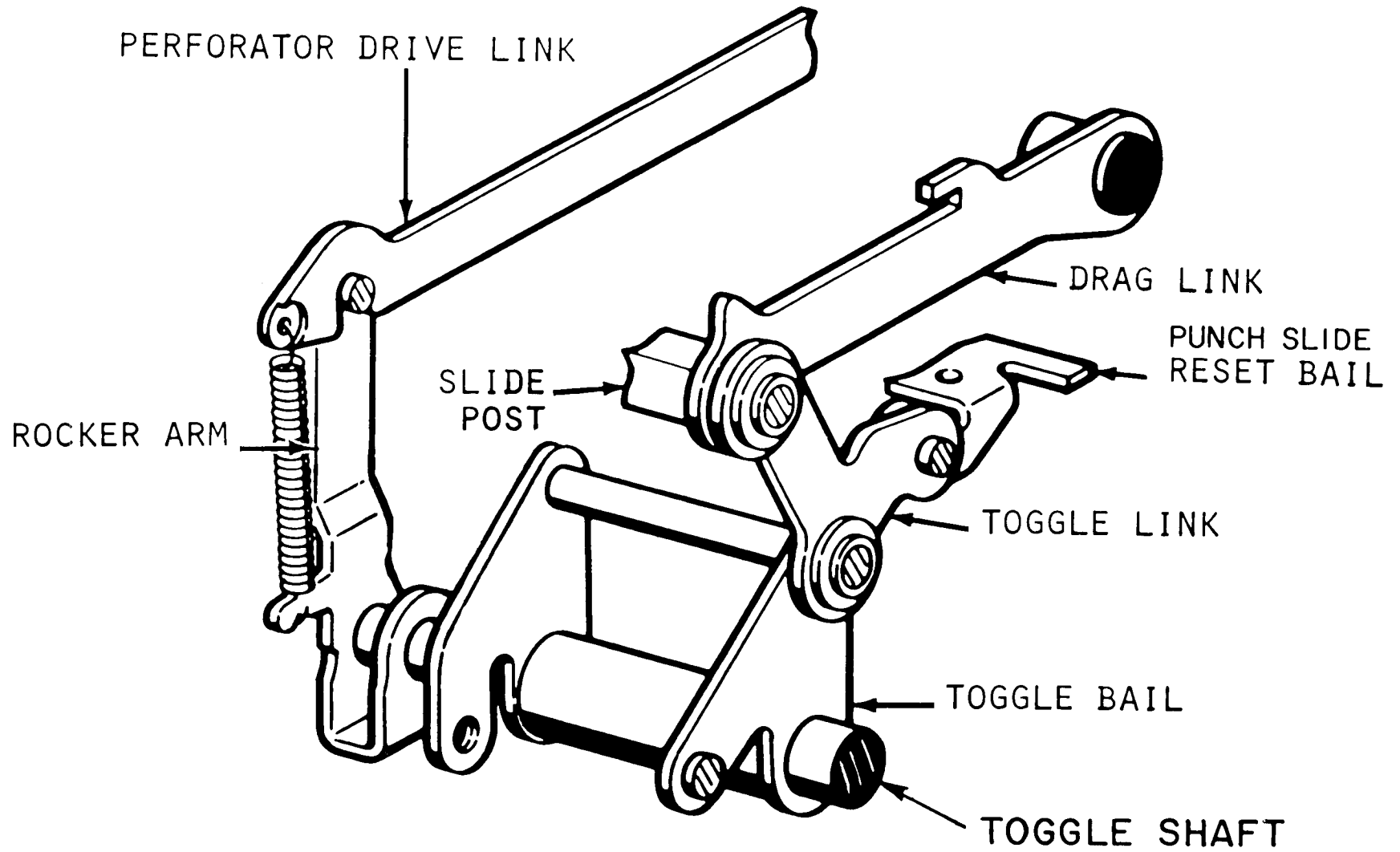

06

MOD 28 ASR-AN/UGC-6K- TOGGLE BAIL OPERATION

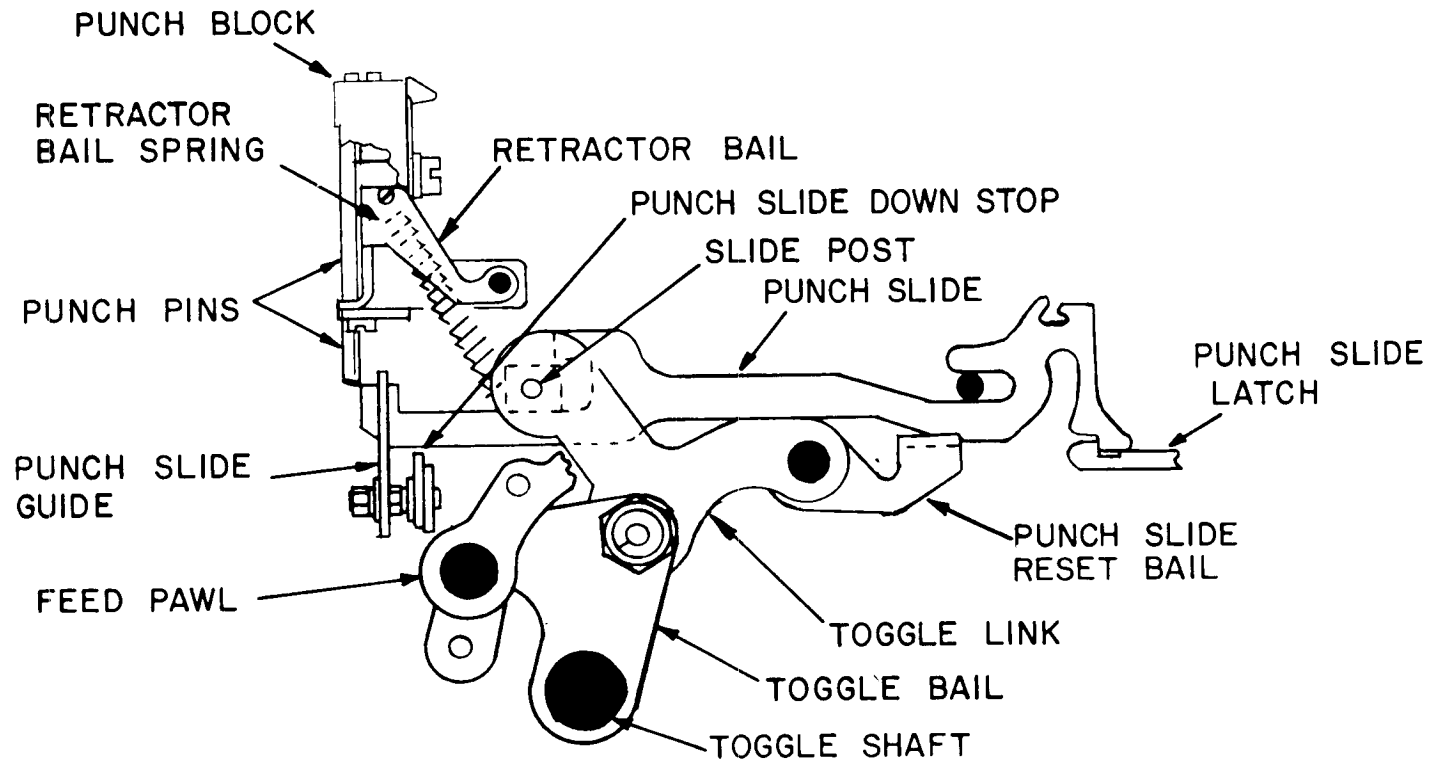

MOD 28 ASR-AN/UGC-6K - PUNCH MECHANISM # 2

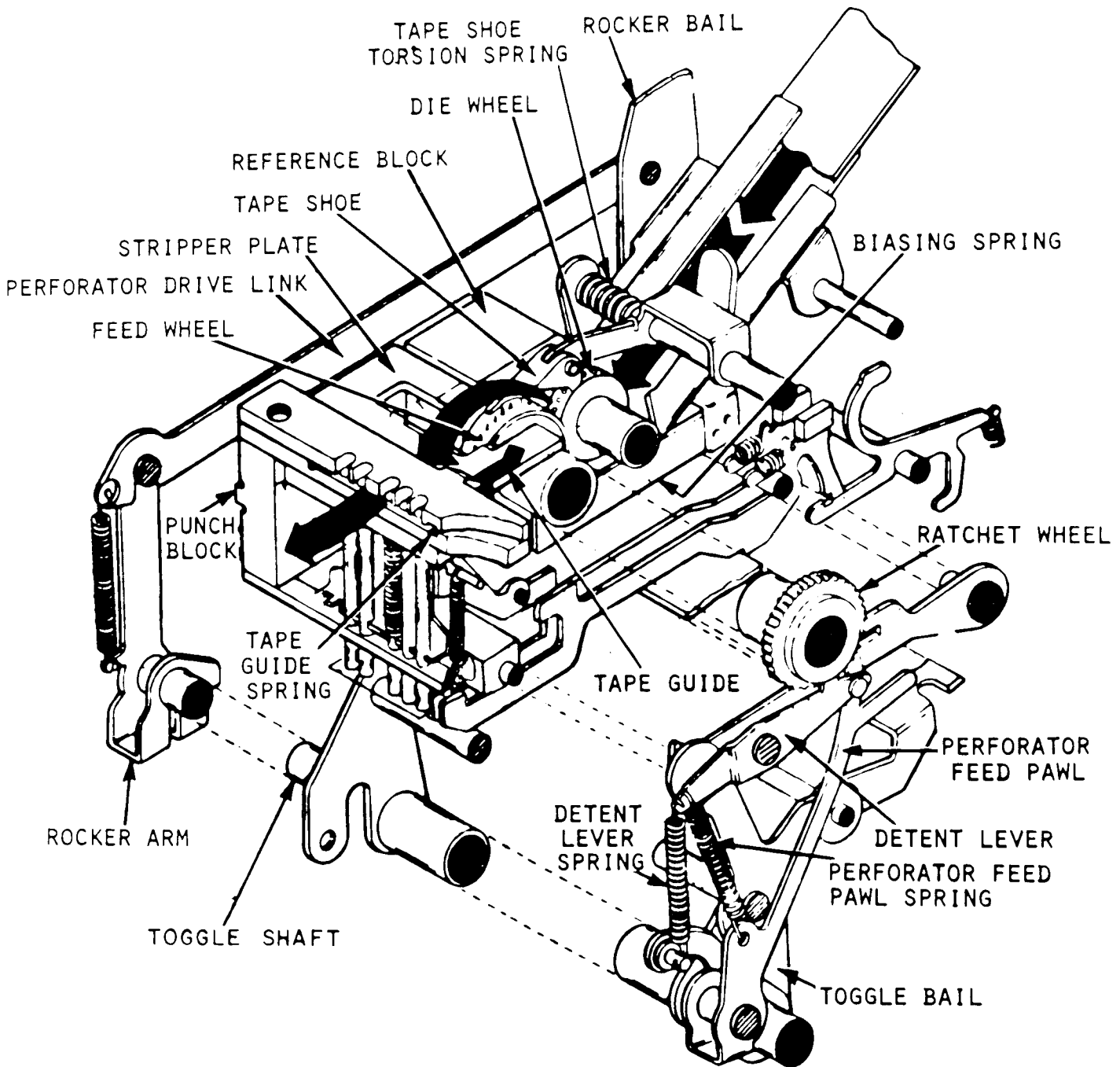

MOD 28 ASR-AN/UGC-6K- TAPE FEED AND FEED HOLE SPACING

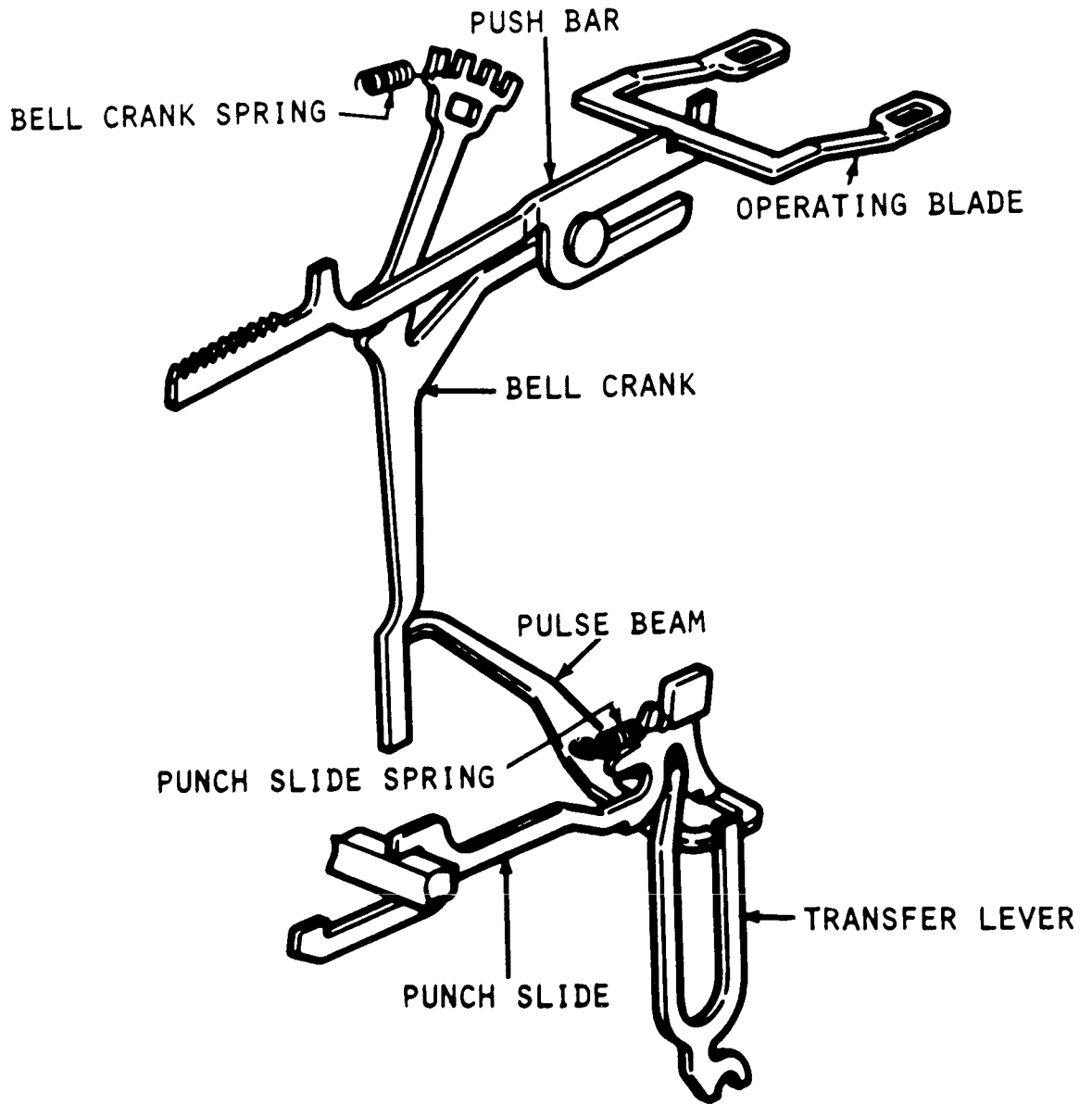
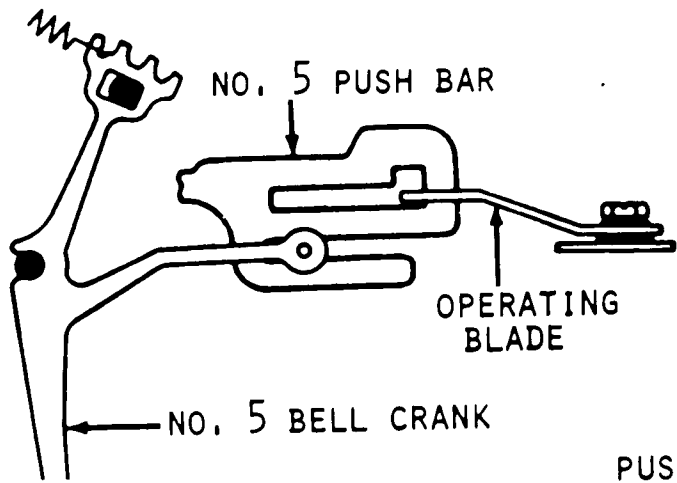

MOD 28 ASR-AN/UGC-6K- POSITIONING PUSH BARS (MARKING)

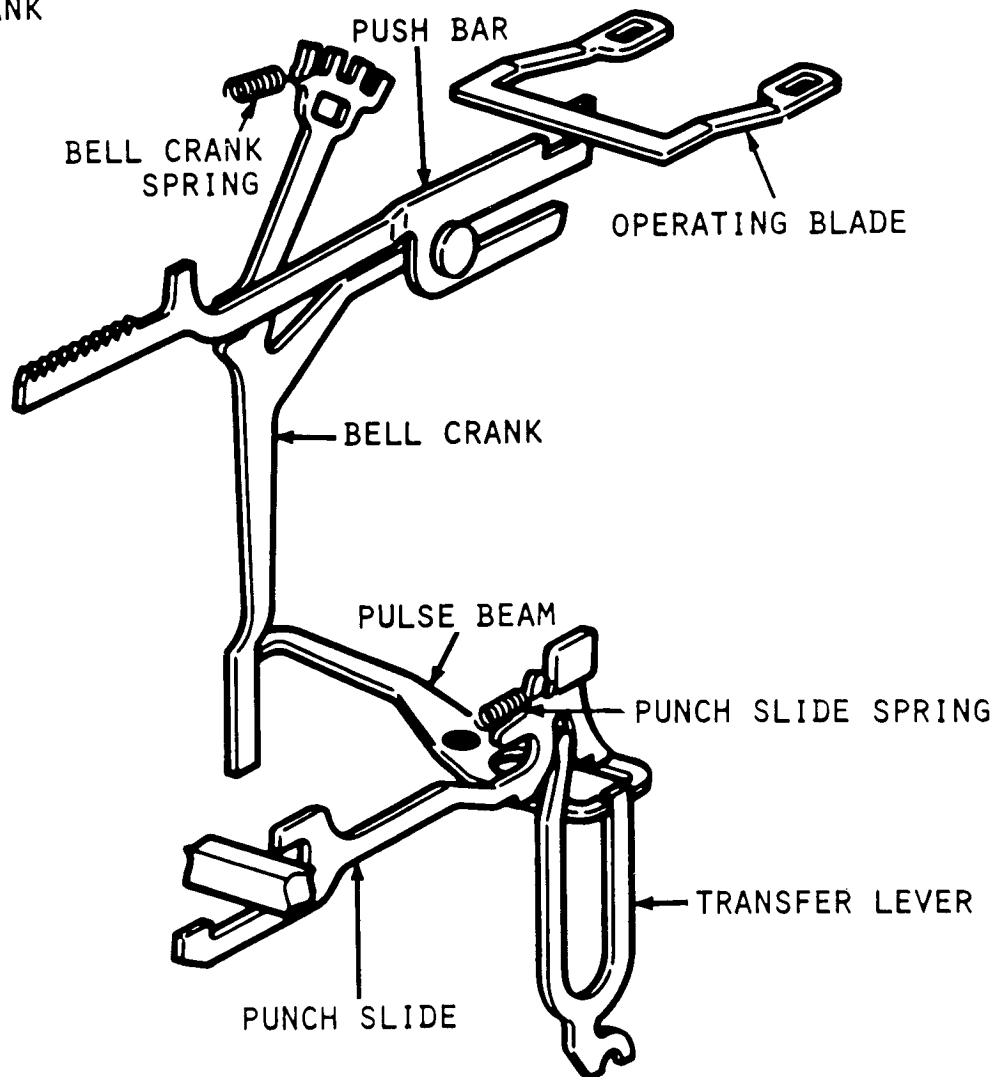
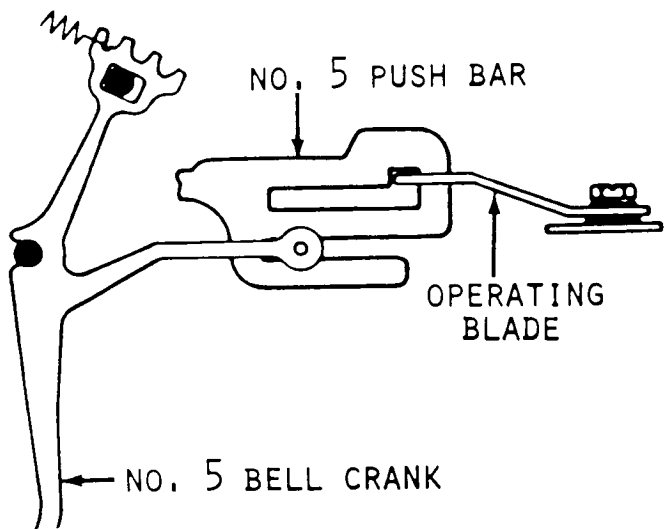

MOD 28 ASR-AN/UGC-6K- POSITIONING PUSH BARS (SPACING)

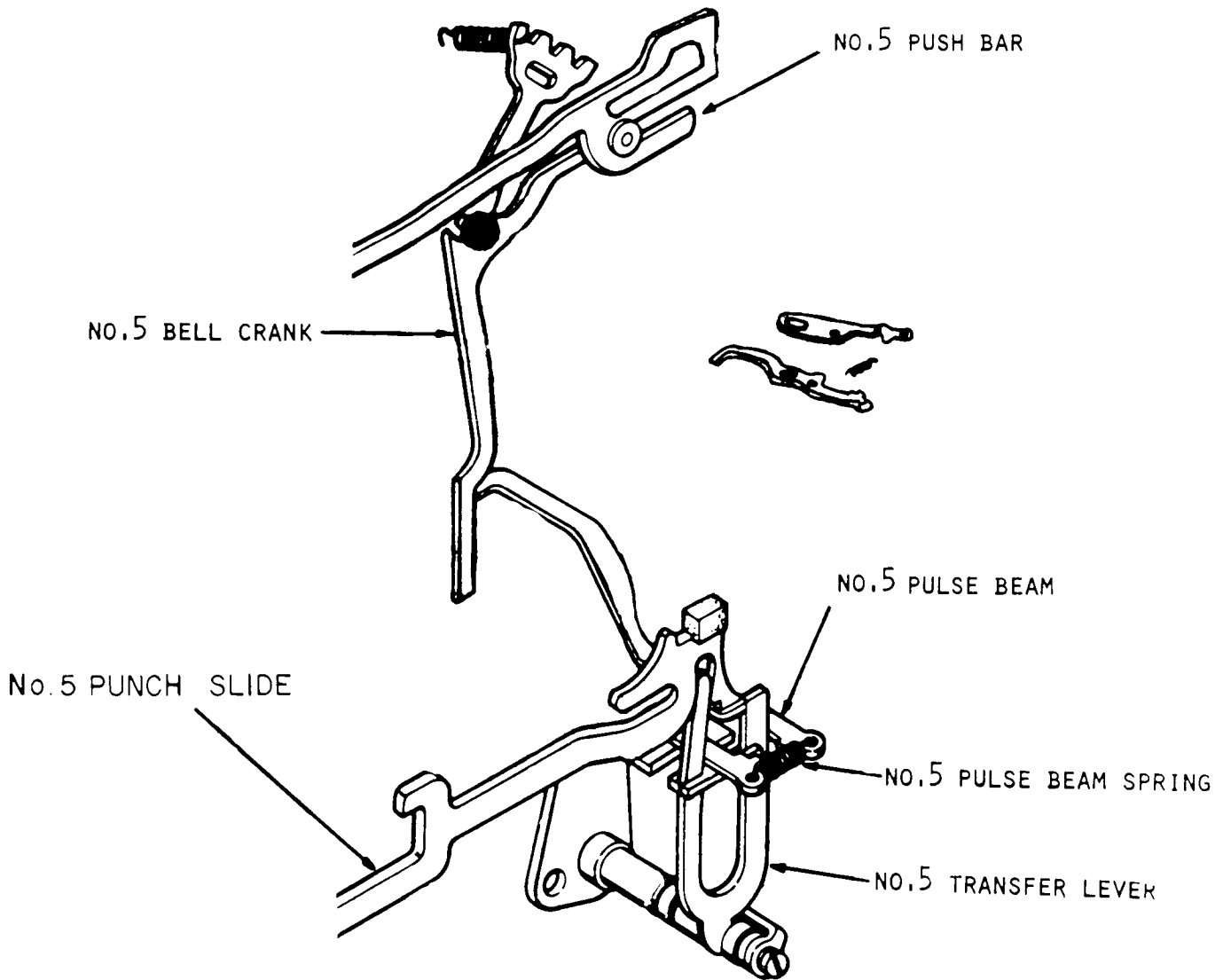

MOD 28 ASR-AN/UGC-6K NO.5 PULSE BEAM

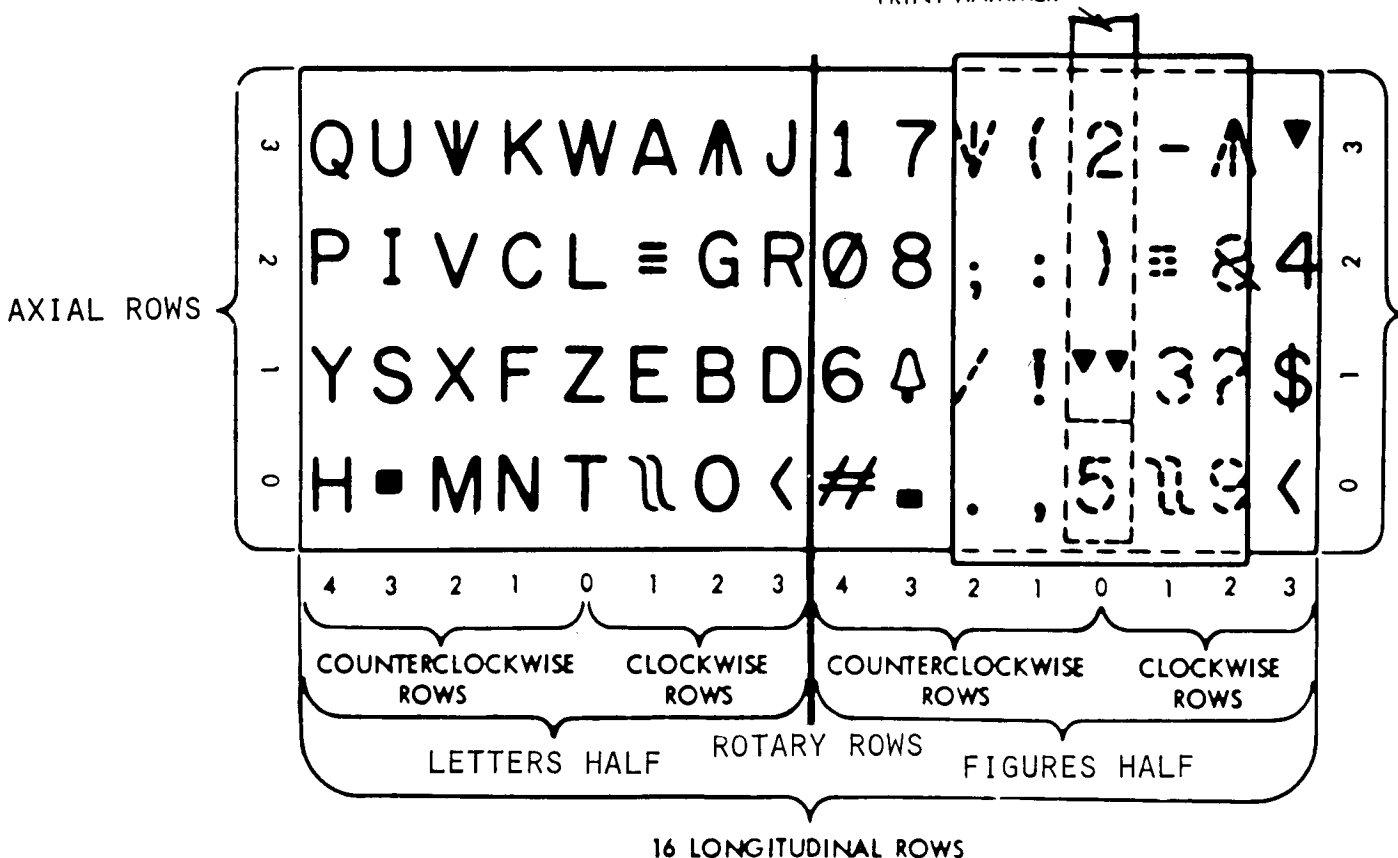
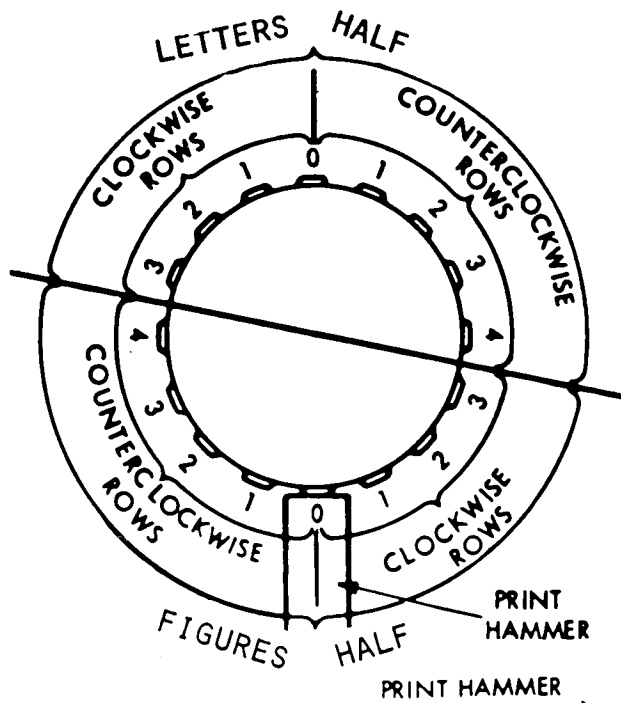

MOD 28 ASR-AN/UGC-6K TYPEWHEEL

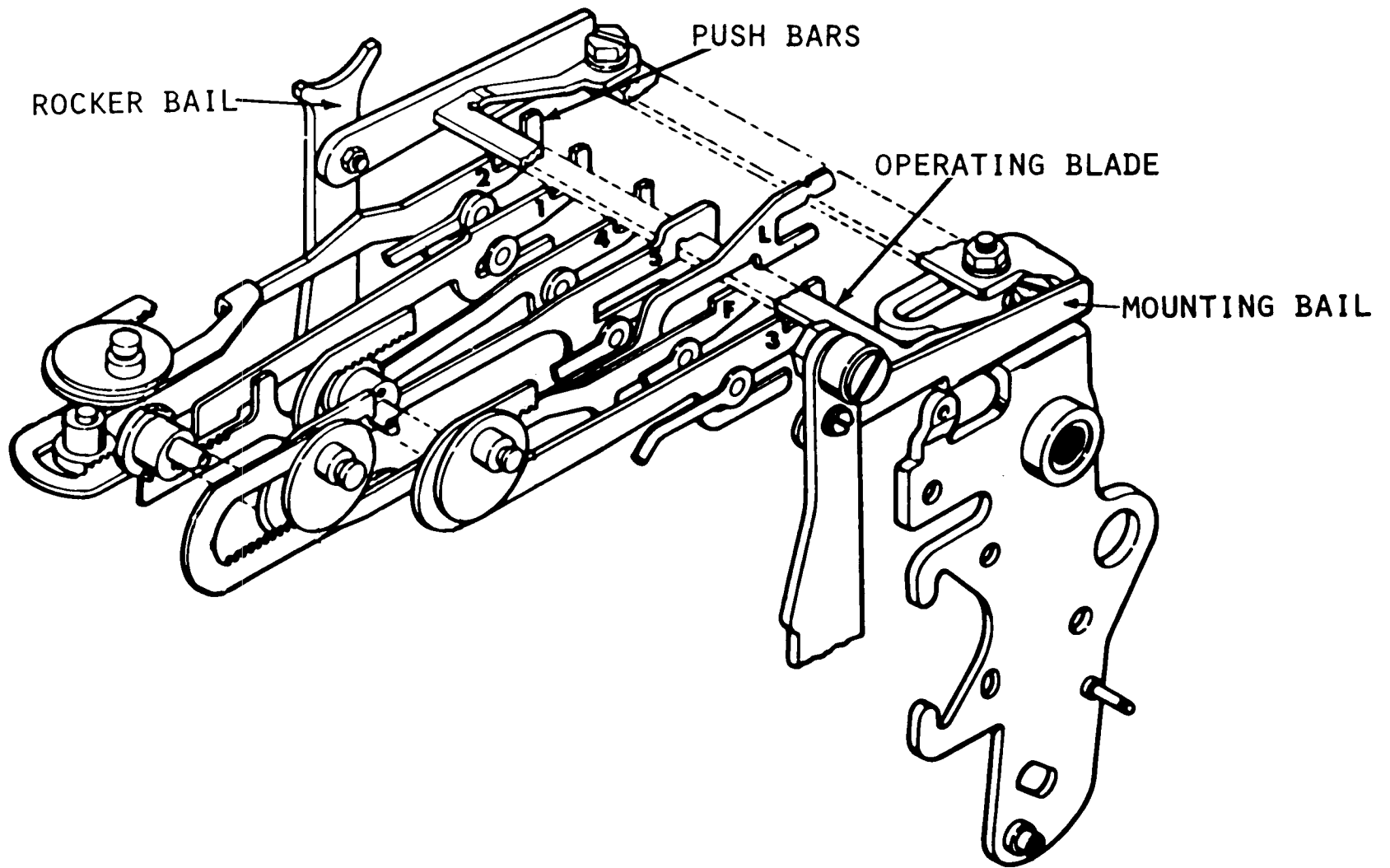

MOD 28 ASR-AN/UGC-6K- OPERATING BLADE

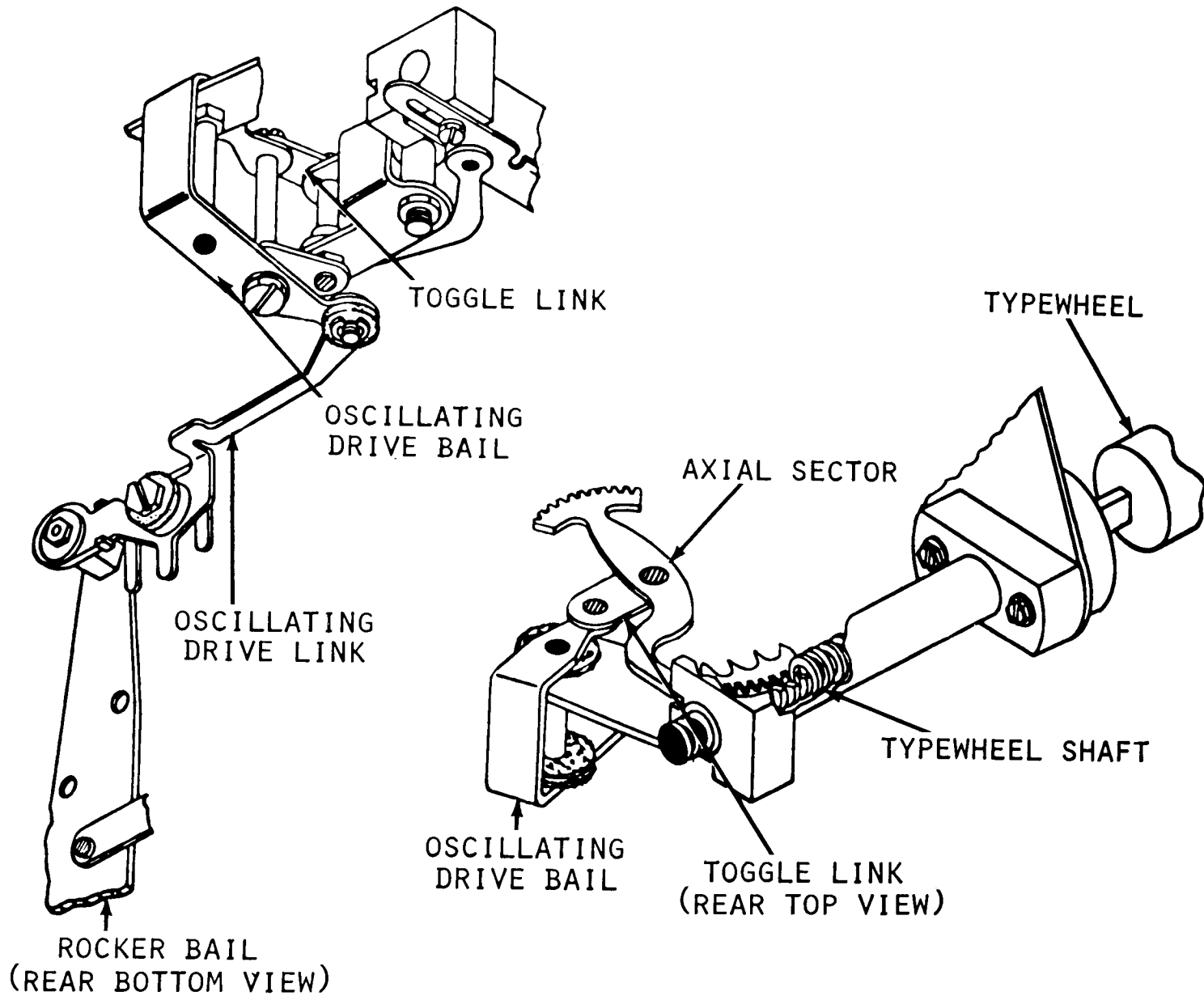

MOD 28 ASR-AN/UGC-6K- AXIAL POSITIONING #1

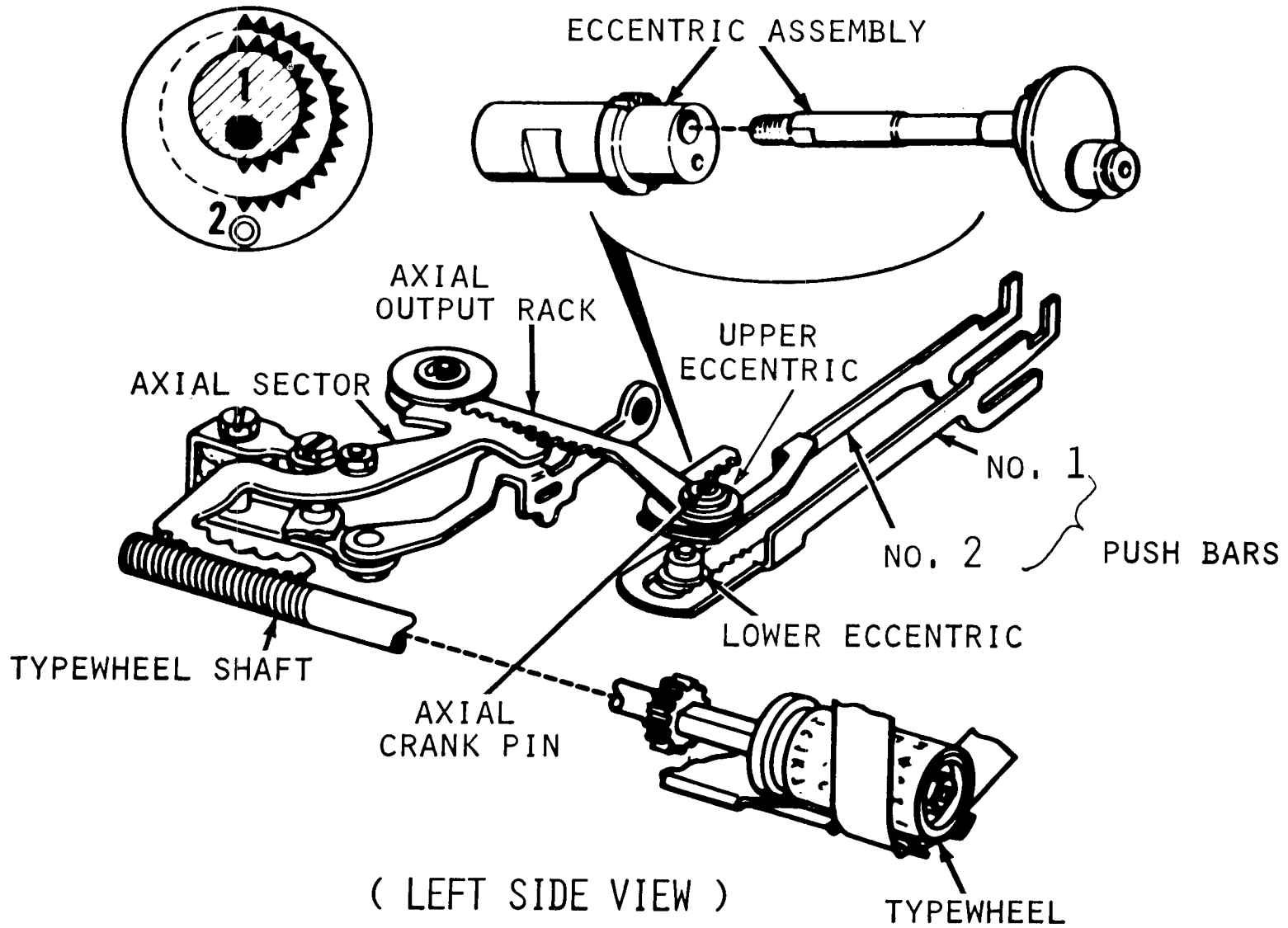

MOD 28 ASR-AN/UGC-6K- AXIAL POSITIONING #2

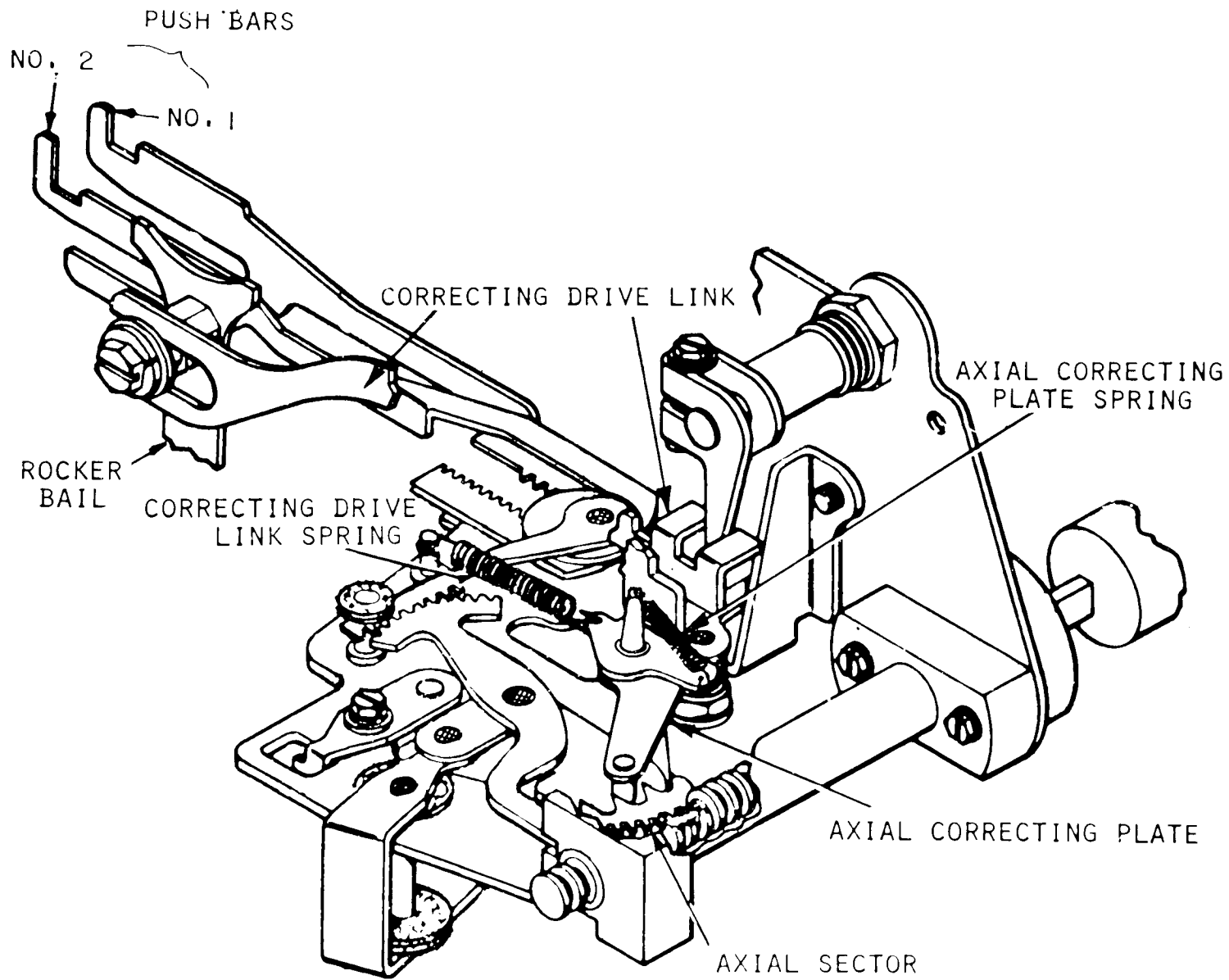

00T

MOD 28 ASP-AN/UGC-6K- AXIAL CORRECTING (REAR VIEW)

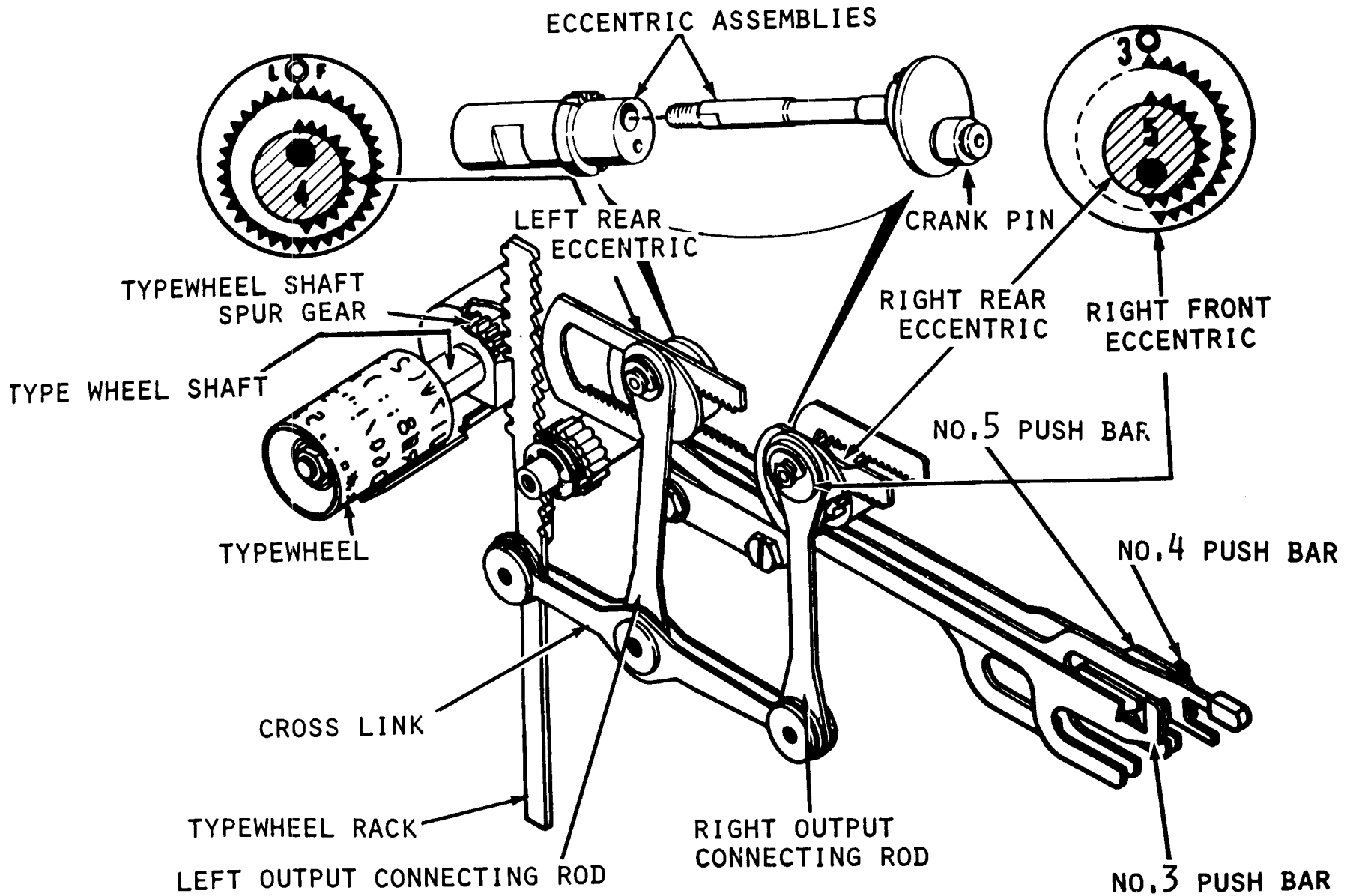

MOD 28 ASR-AN/UGC-6K- ROTARY POSITIONING

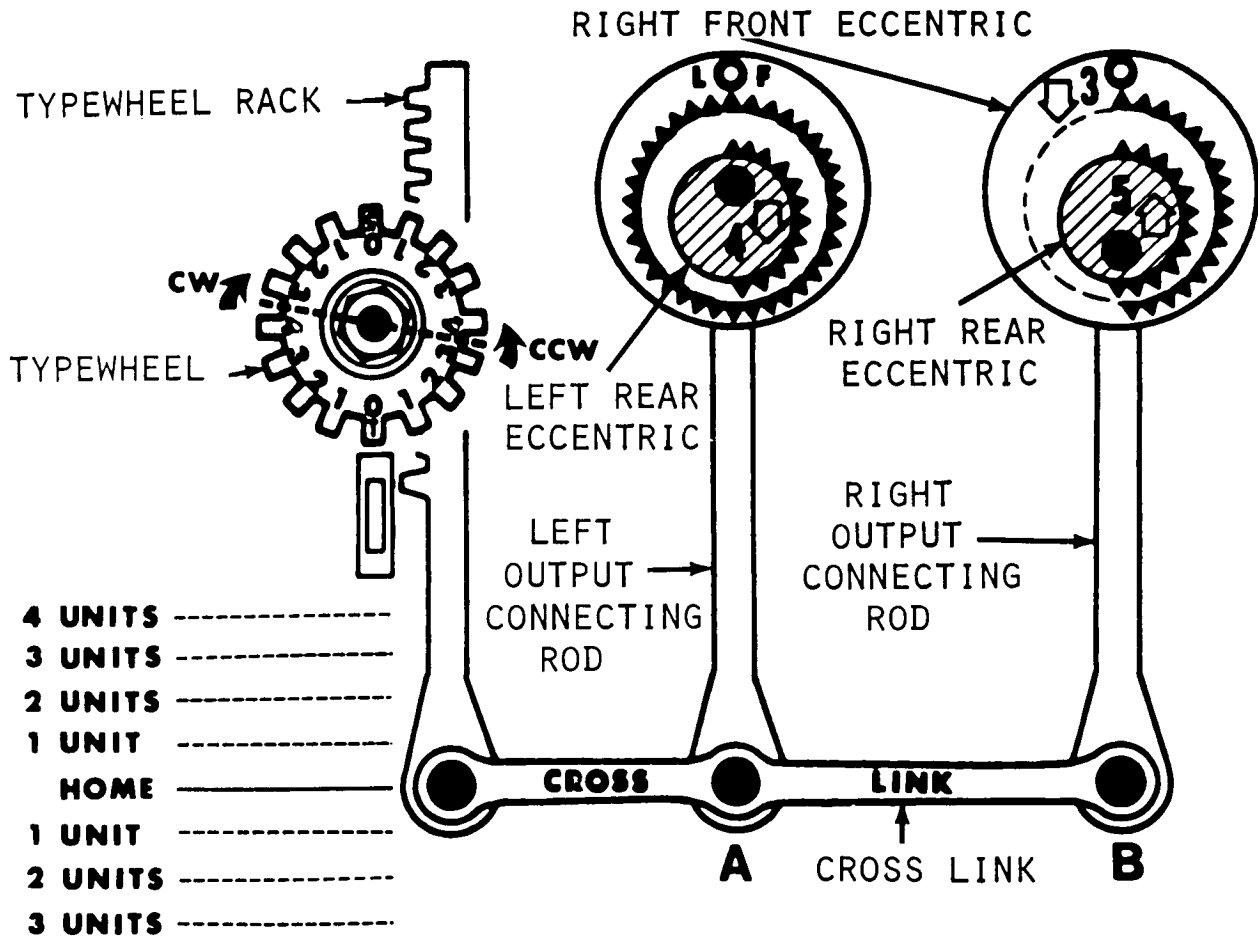

(EXAMPLE 1)

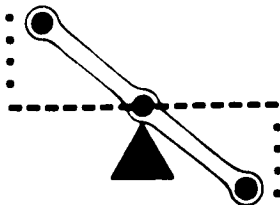

NO. 3 (MK) = 4 UNITS CCW

(EXAMPLE 2)



NO. 4 (MK) = 2 UNITS CW

(EXAMPLE 3)

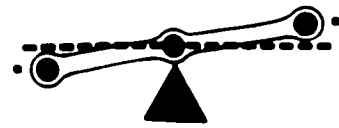

NO. 5 (SP) = 1 UNIT CW

MOD 28 ASR-AN/UGC-6K- CROSS LINK OPERATION

4-3-10D

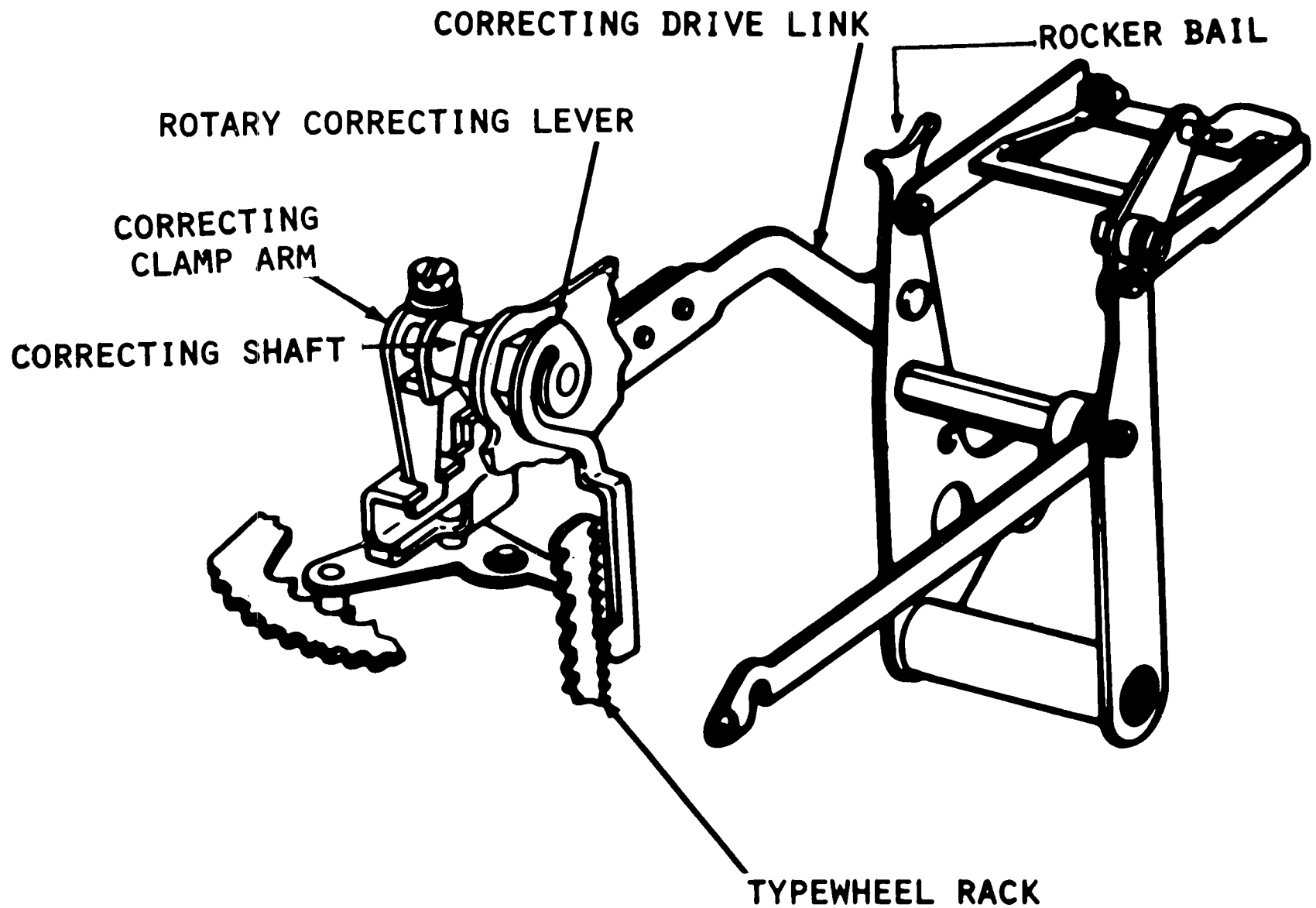

103

MOD 28 ASR-AN/UGC-6K ROTARY CORRECTING

104

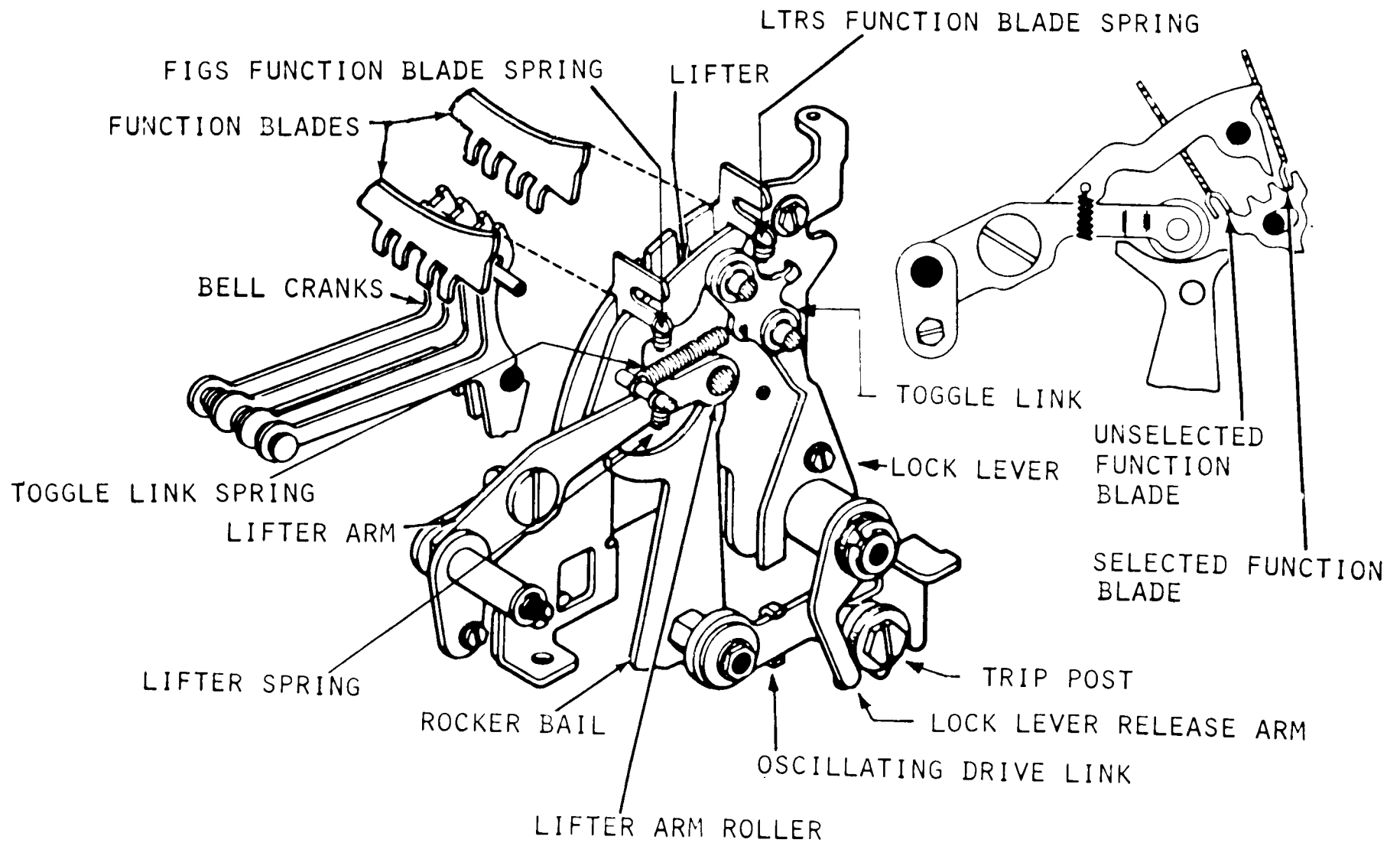

MOD 28 ASR-AN/UGC-6K FUNCTION BLADE SENSING (REAR VIEW)

4-3-12D

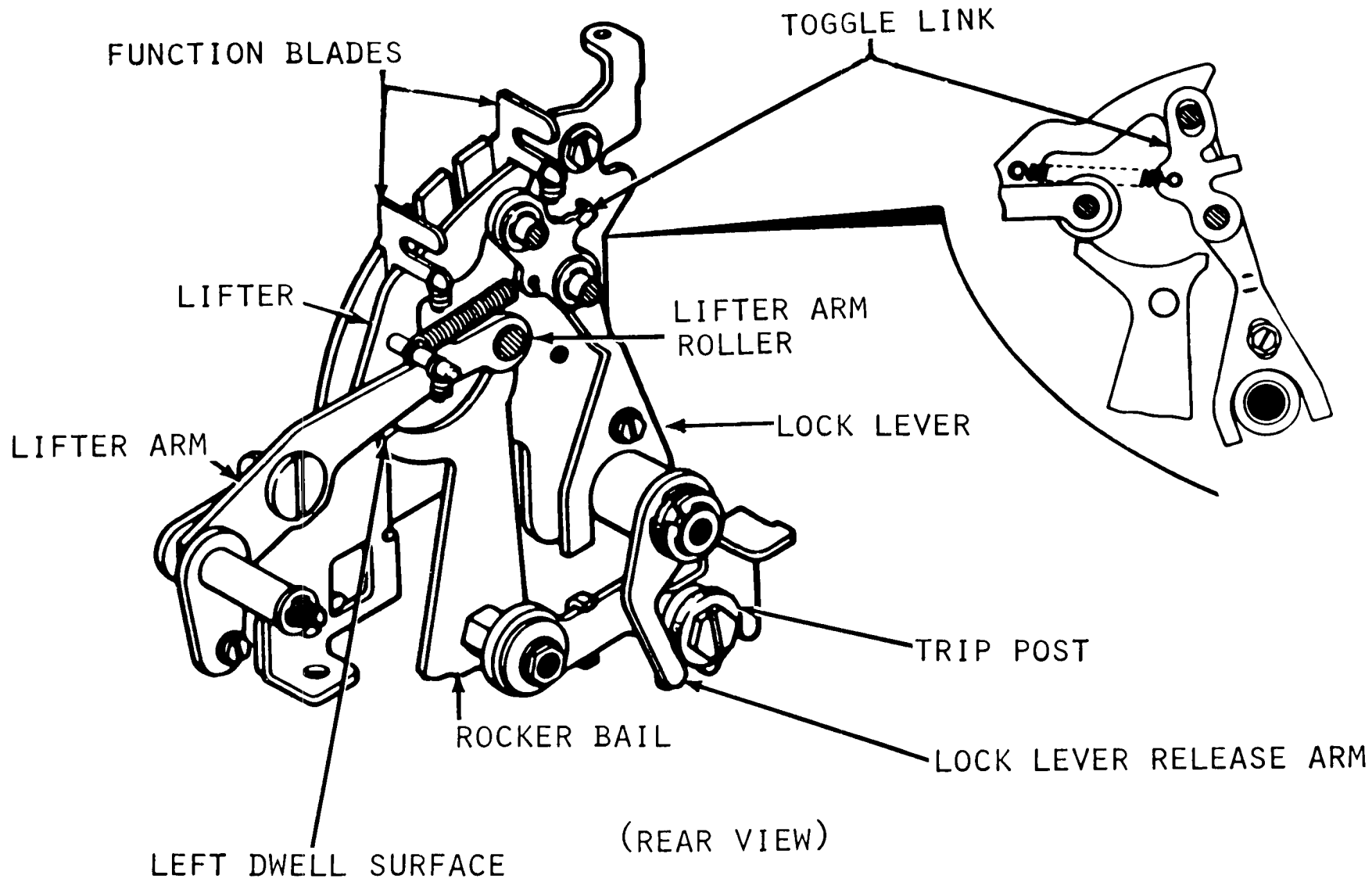

MOD 28 ASR-AN/UGC-6K- TOGGLE LINK OPERATION (REAR VIEW)

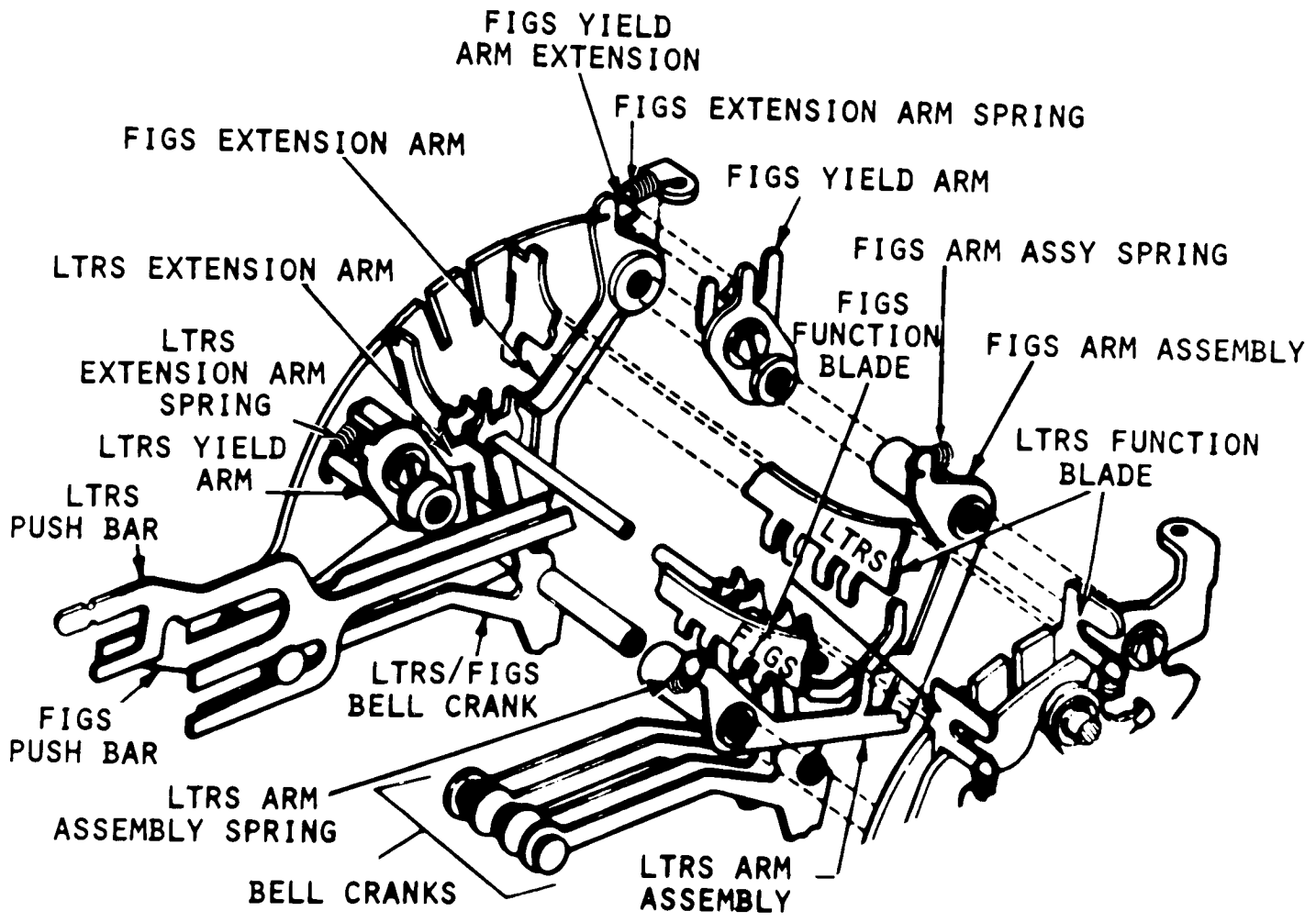

LETTERS POSITION

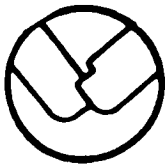

FIGURES POSITION



MOD 28 ASR-AN/UGC-6K- LTRS/FIGS SHIFT #1 (REAR VIEW)

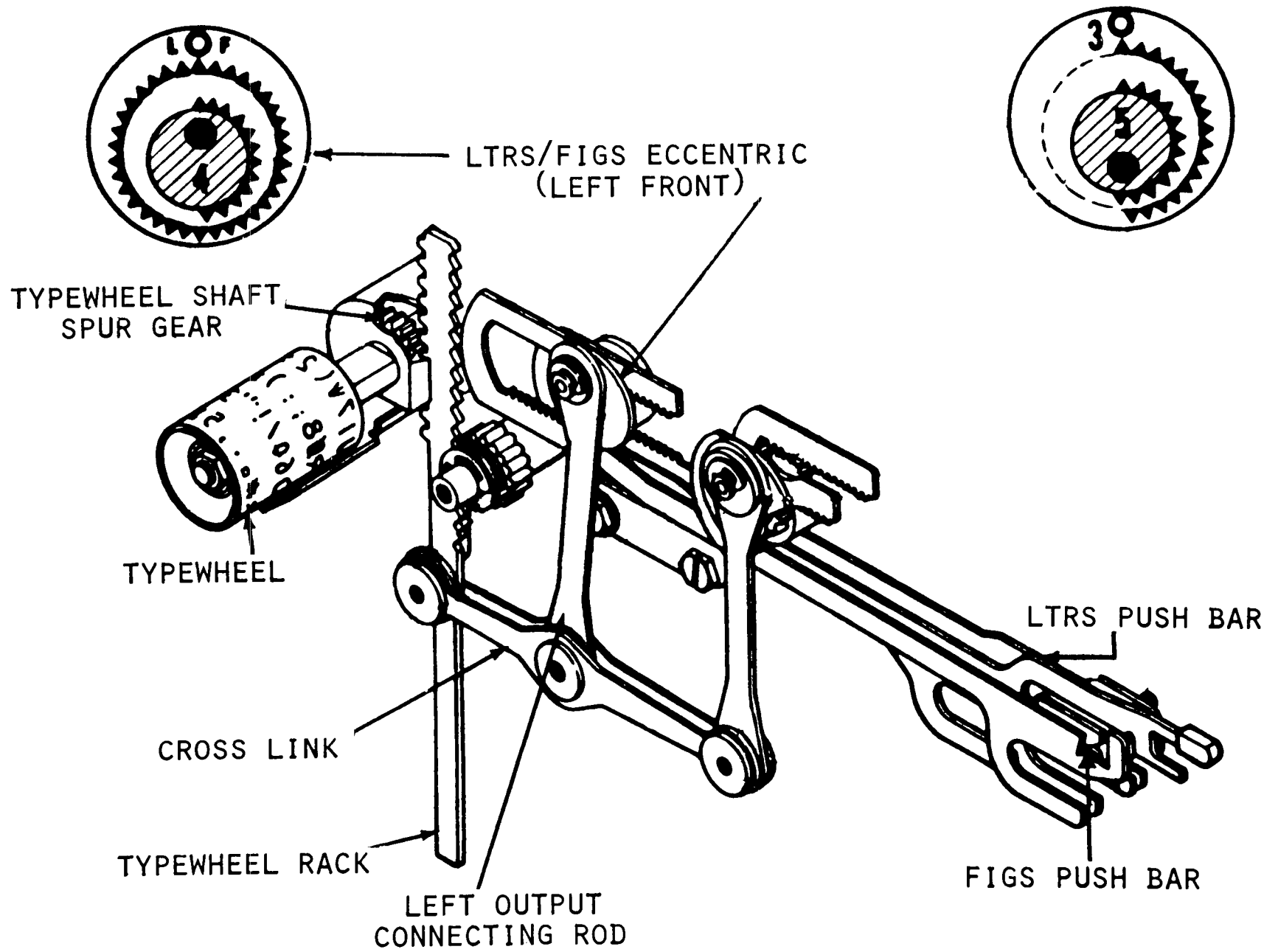

MOD 28 ASR-AN/UGC-6K- LTRS/FIGS SHIFT #2

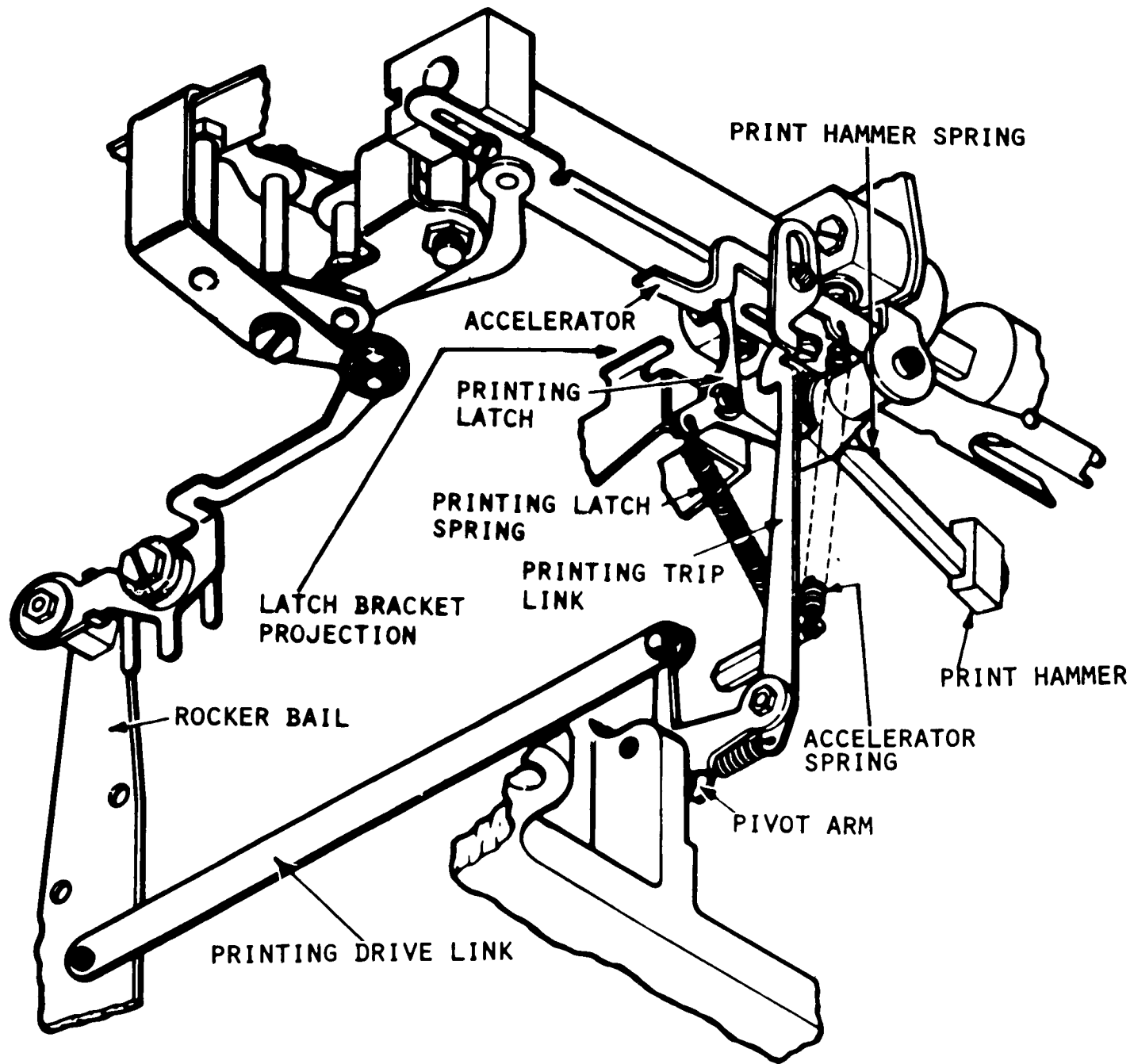

MOD 28 ASR-AN/UGC-6K PRINTING MECHANISM (LEFT REAR VIEW)

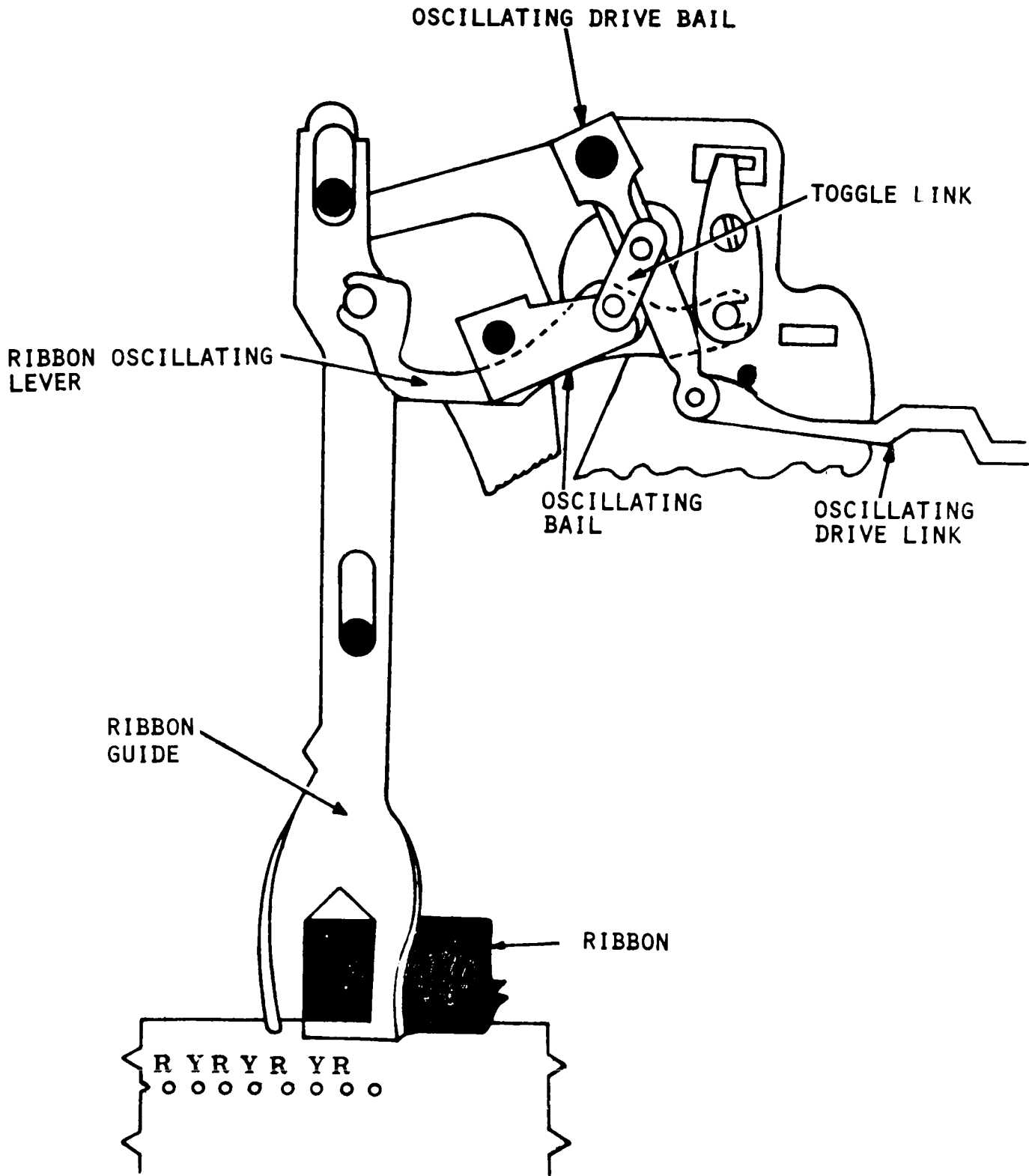

MOD 28 ASR-AN/UGC-6K' RIBBON OSCILLATION (TOP VIEW)

4-4-2D

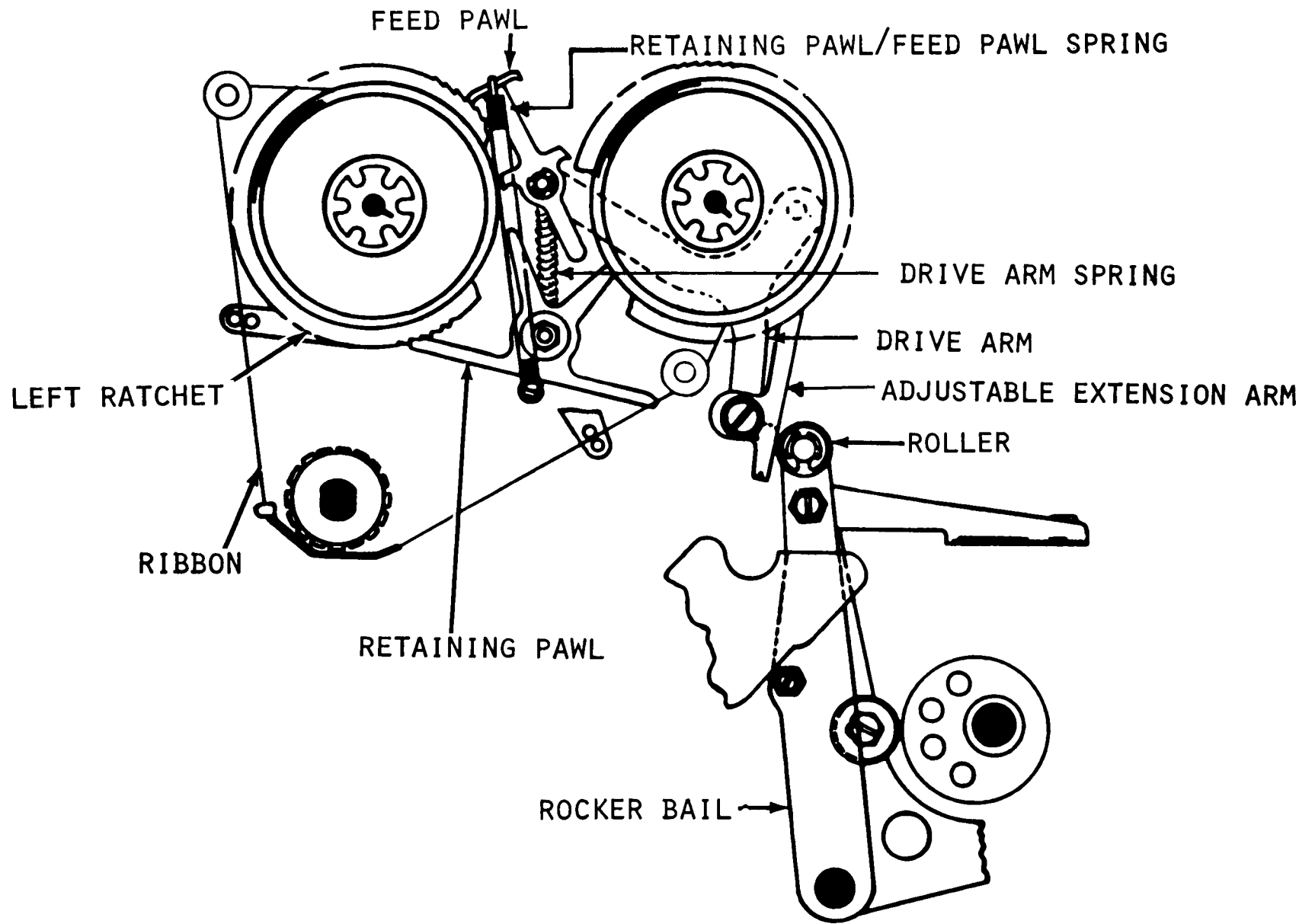

MOD 28 ASR-AN/UGC-6K- RIBBON FEED

111

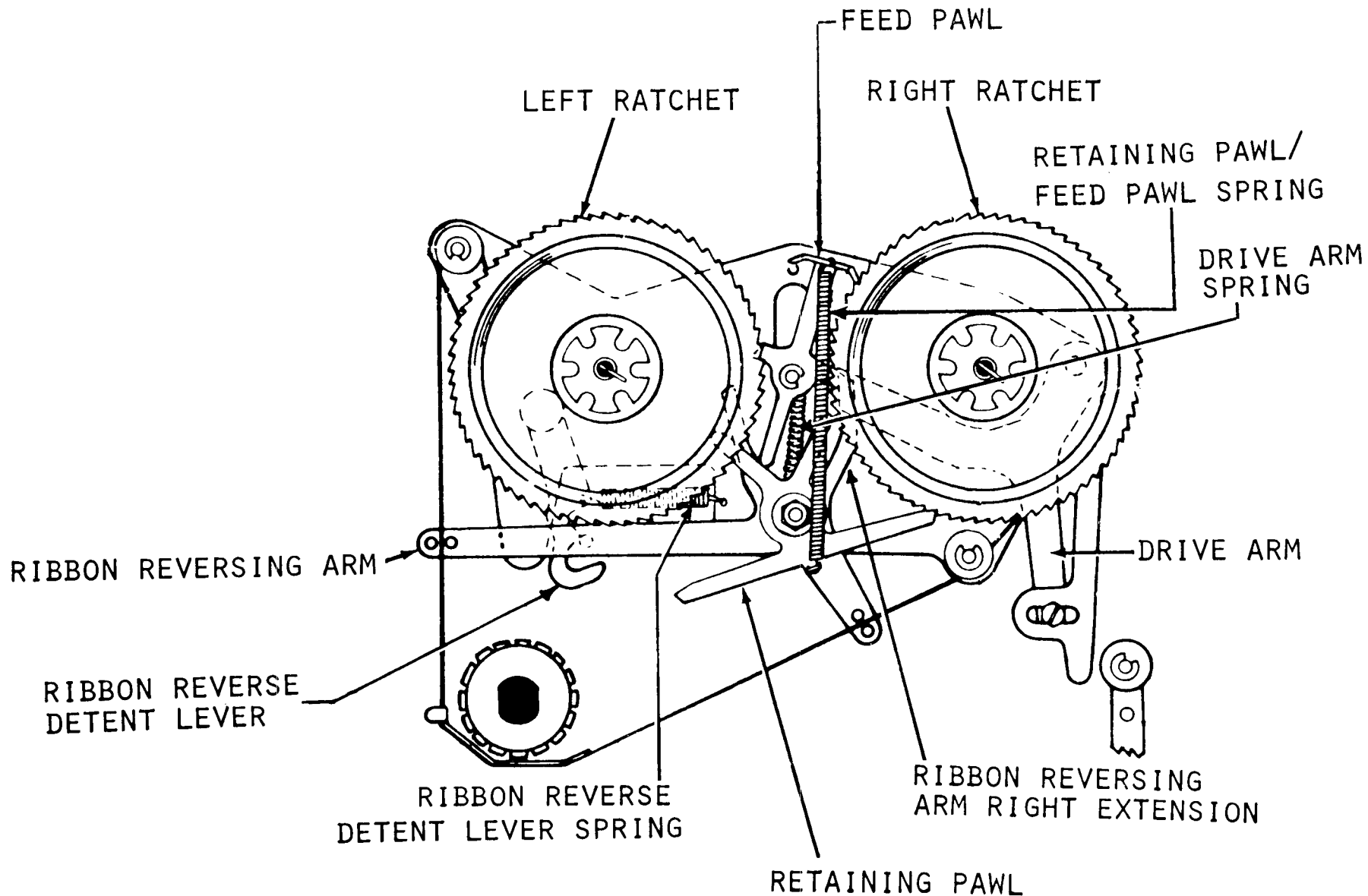

MOD 28 ASR-AN/UGC-6K- RIBBON REVERSE

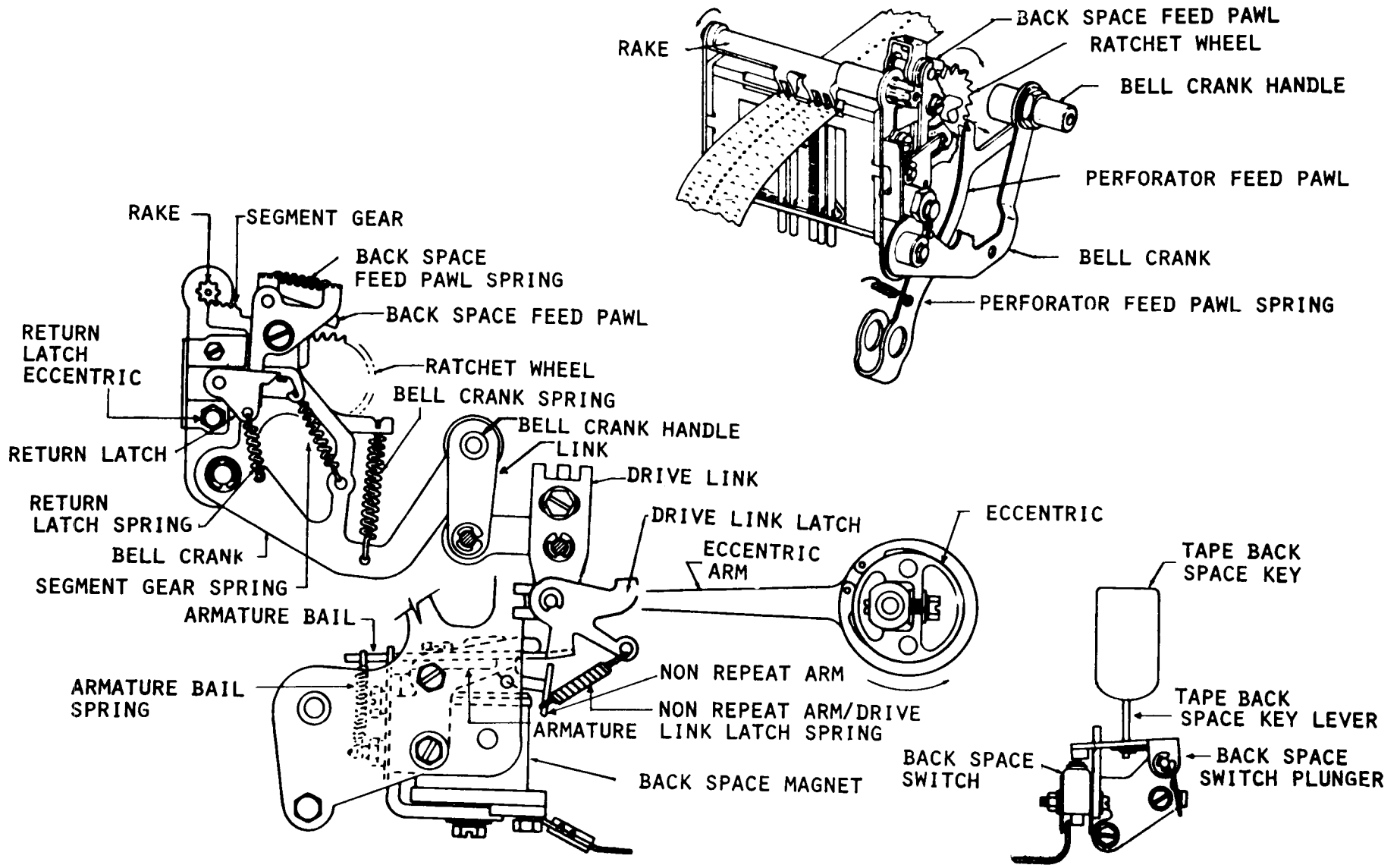

MOD 28 ASR-AN/UGC-6K POWER DRIVE BACK SPACE

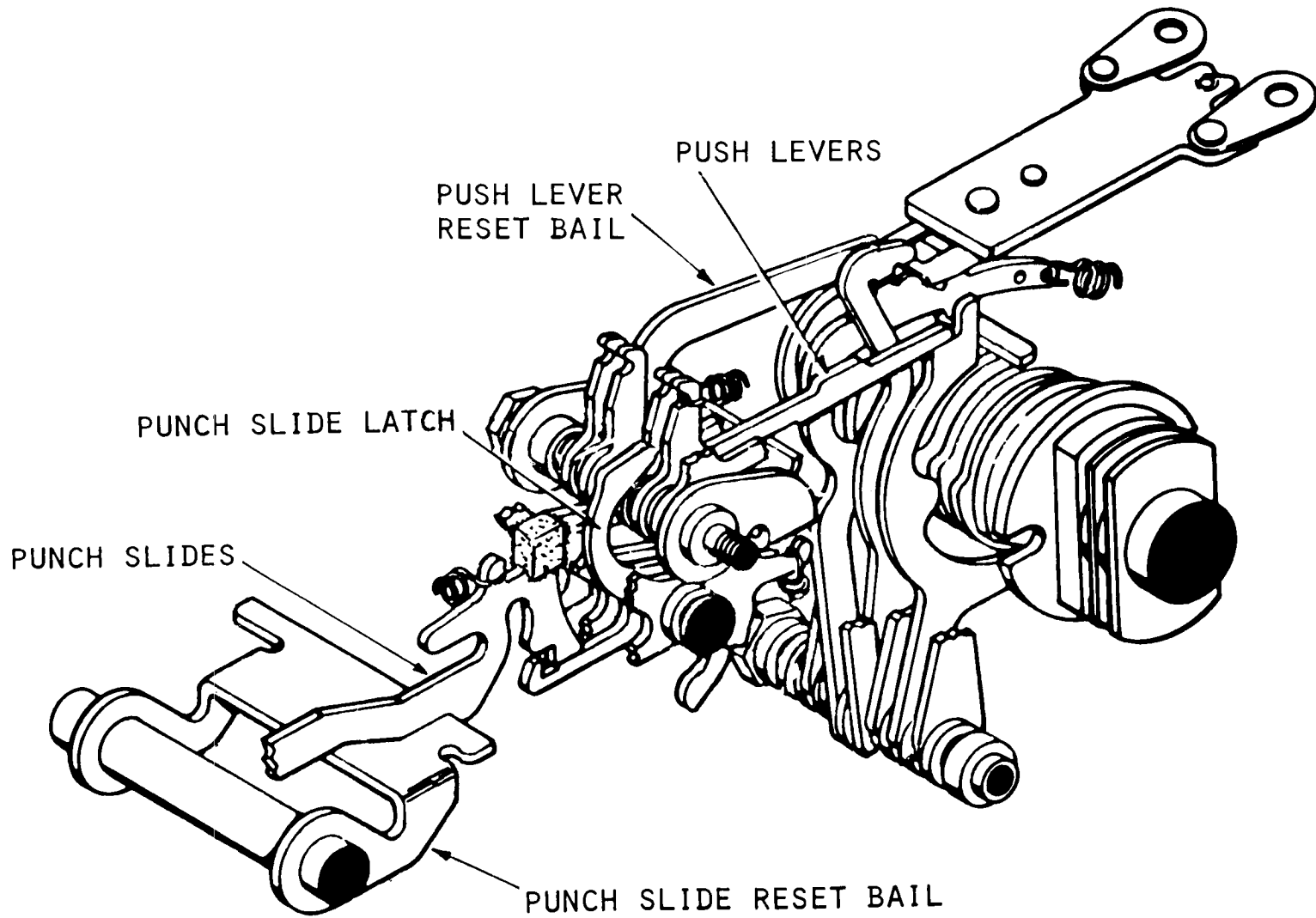

MOD 28 ASR-AN/UGC-6K REPERFORATOR SELECTOR MECHANISM

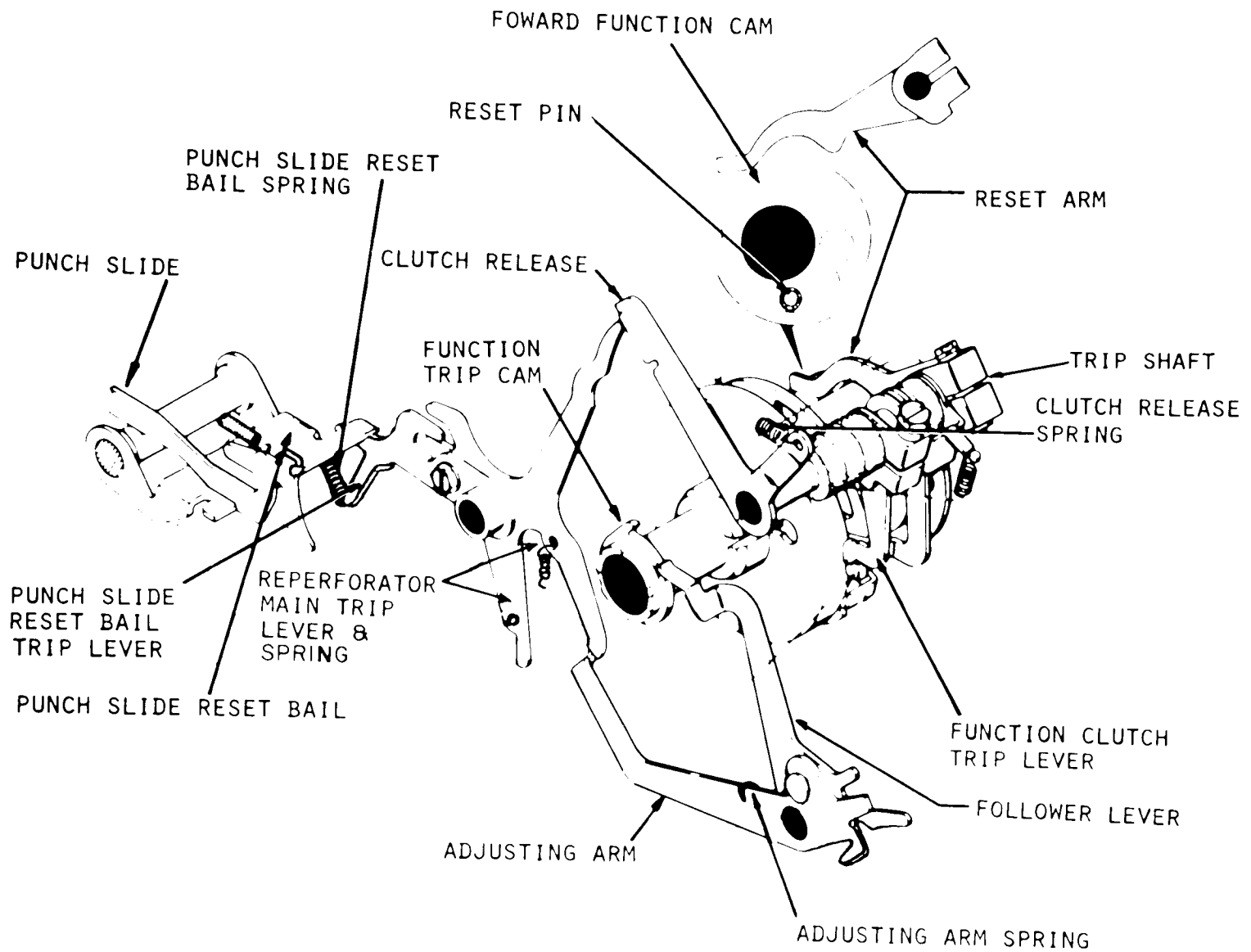

MOD 28 ASR-AN/UGC-6K REPERFORATOR FUNCTION CLUTCH TRIP

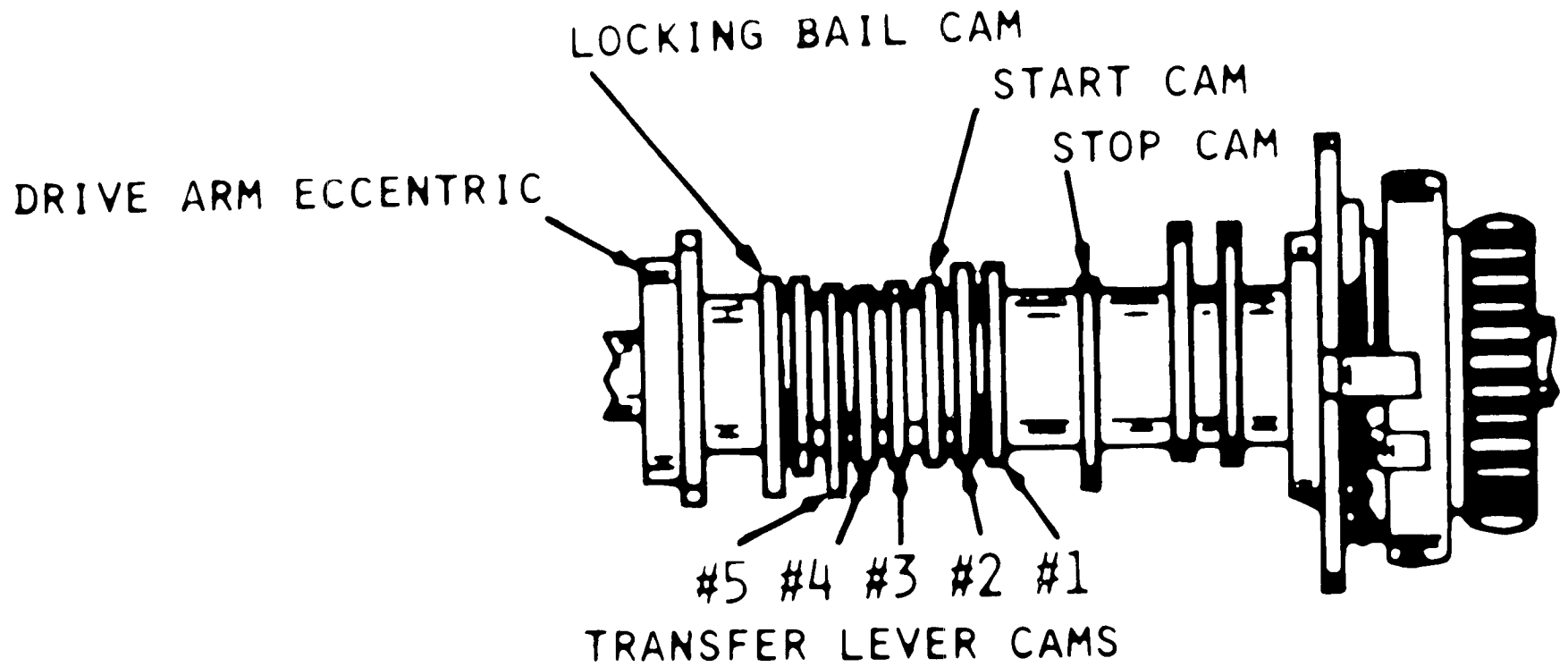

MOD 28 ASR-AN/UGC-6K TD CAM SHAFT ASSEMBLY (RIGHT VIEW)

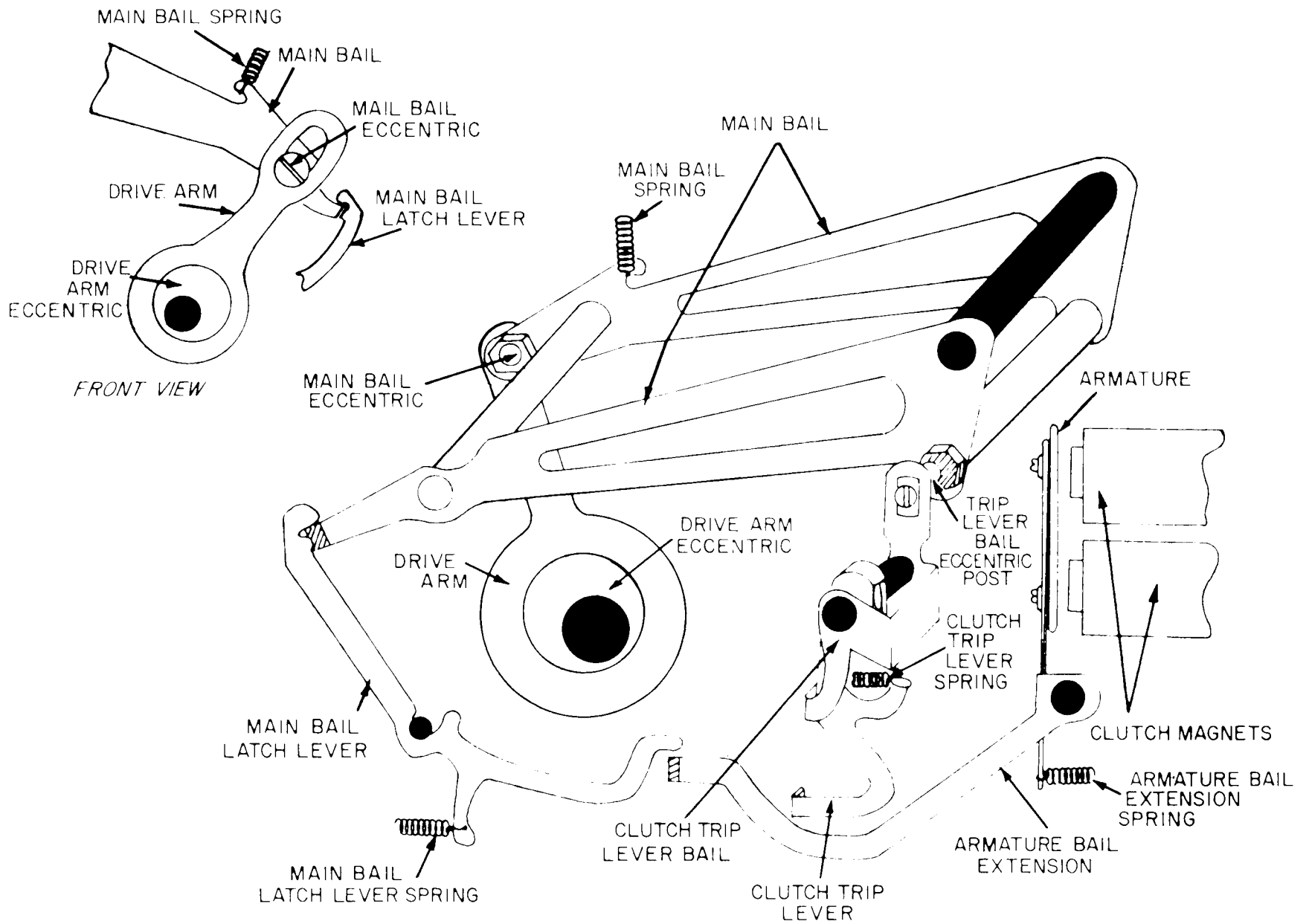

MOD 28 ASR-AN/UGC-6K TD CLUTCH TRIP (REAR VIEW)

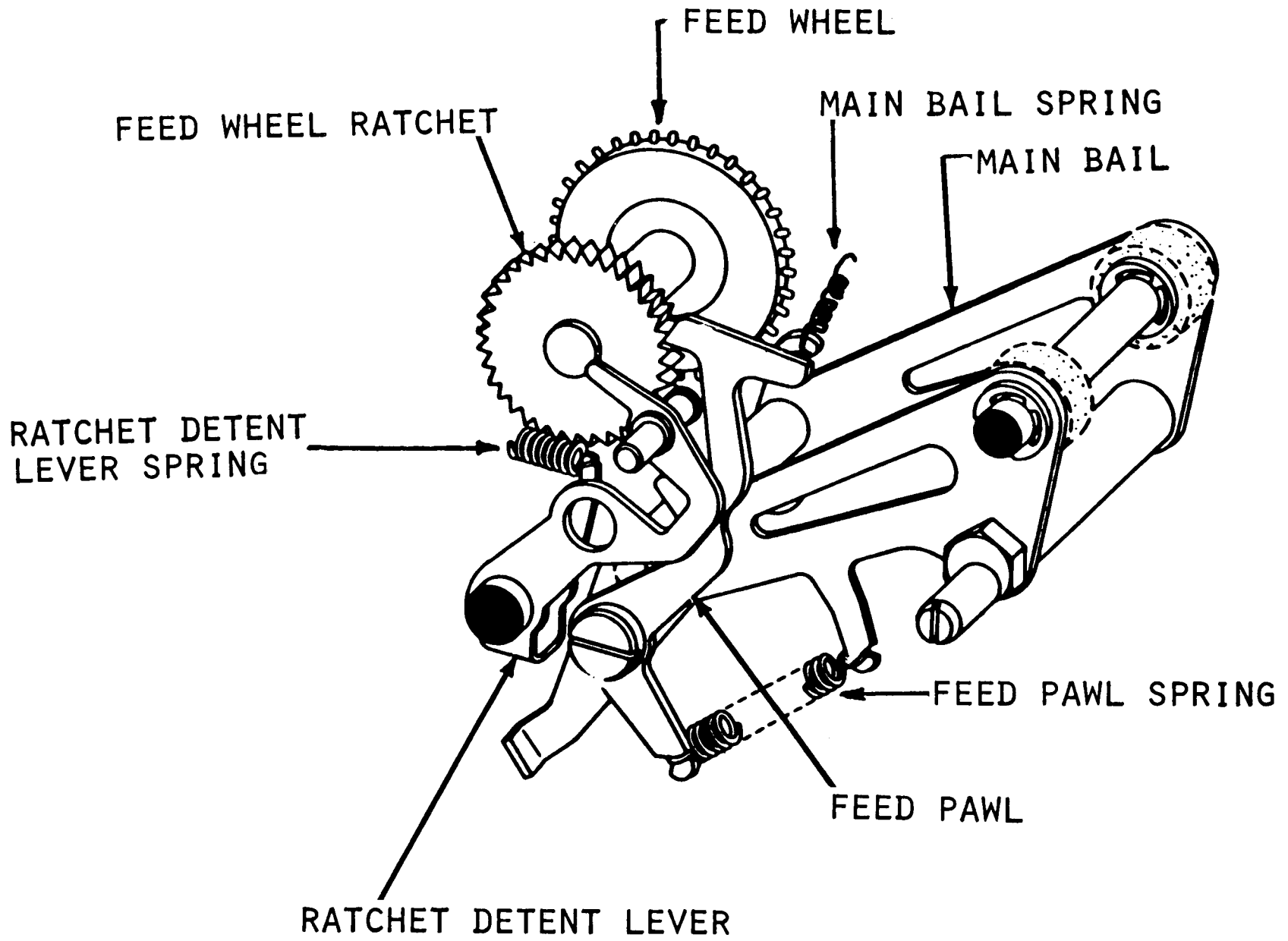

117

MOD 28 ASR-AN/UGC-6K- TD TAPE FEED (REAR VIEW)

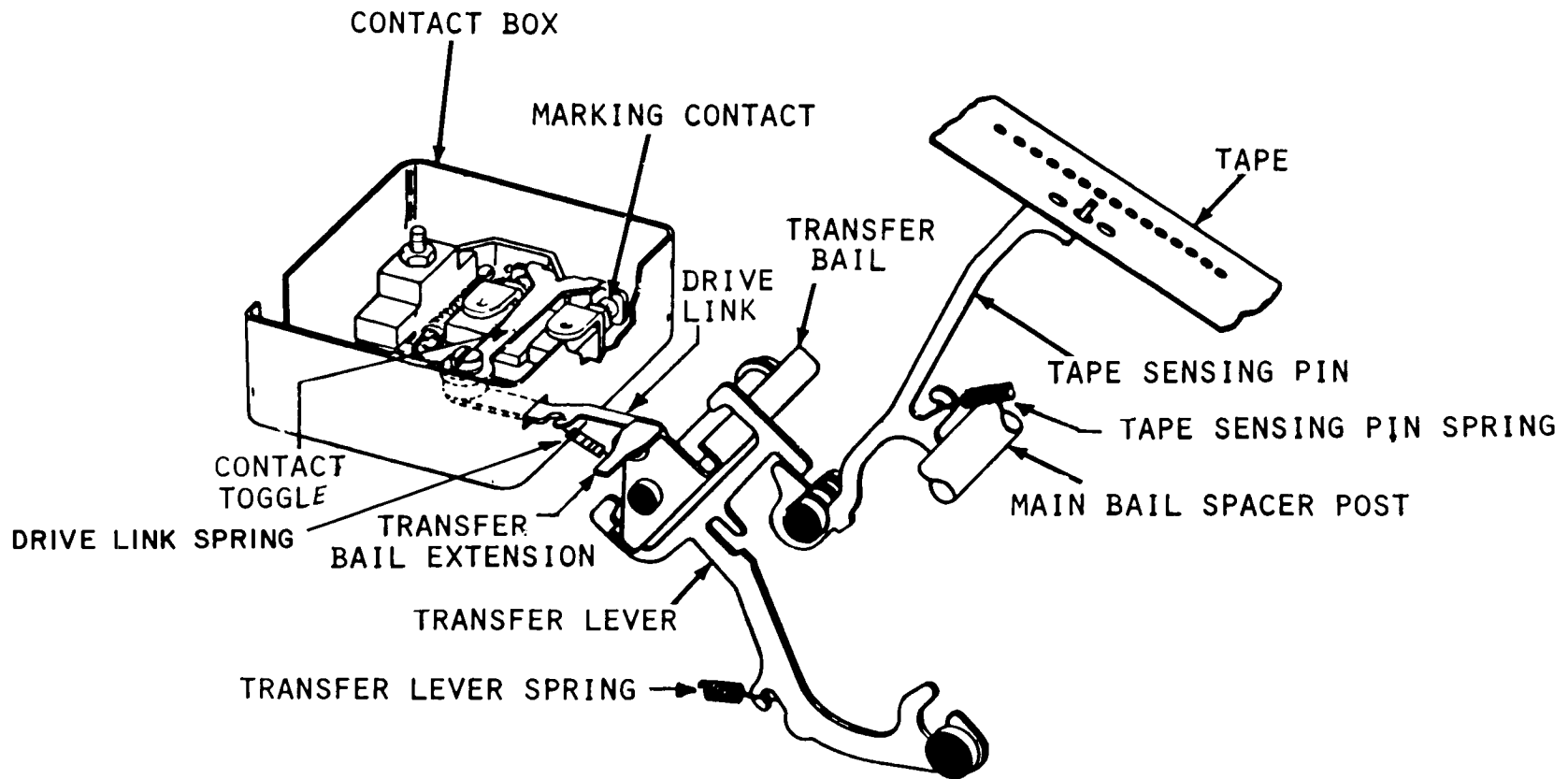
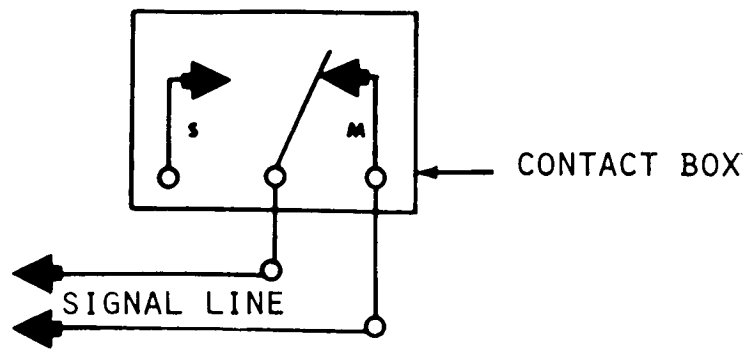

MOD 28 ASR-AN/UGC-6K- TAPE SENSING (MARK)

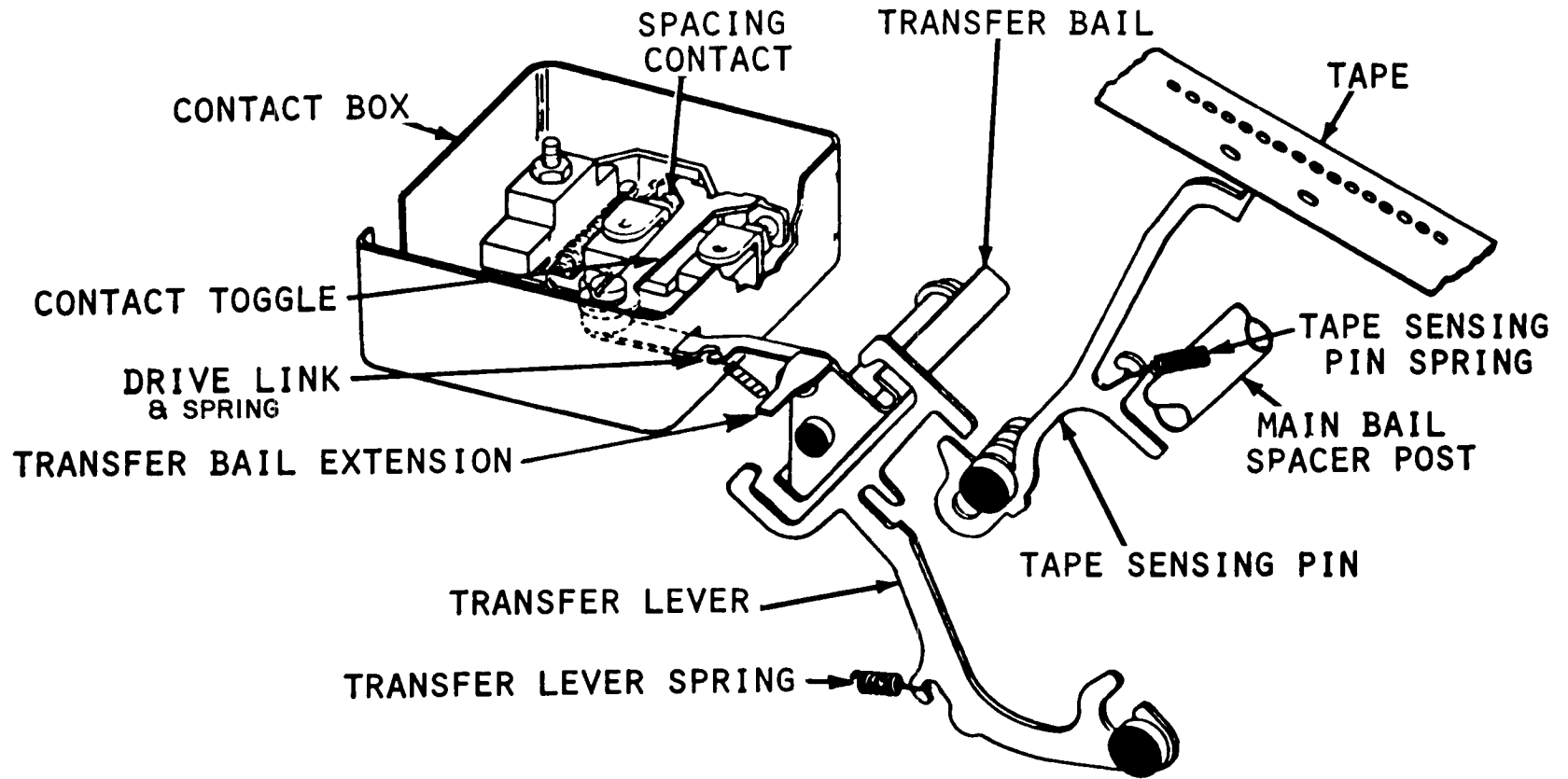
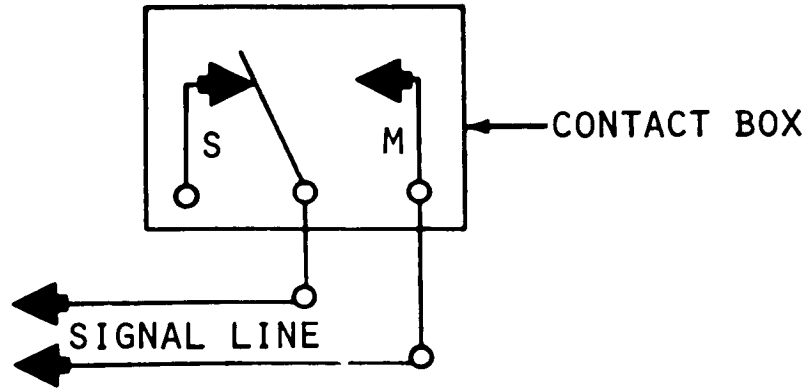

MOD 28 ASR-AN/UGC-6K- TAPE SENSING (SPACE)

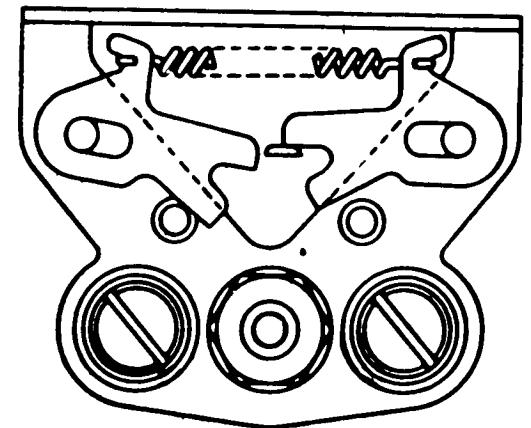
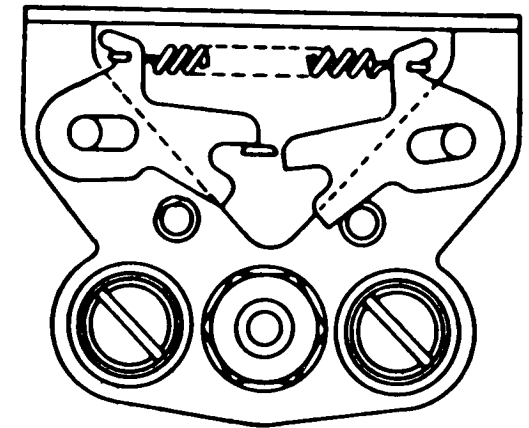
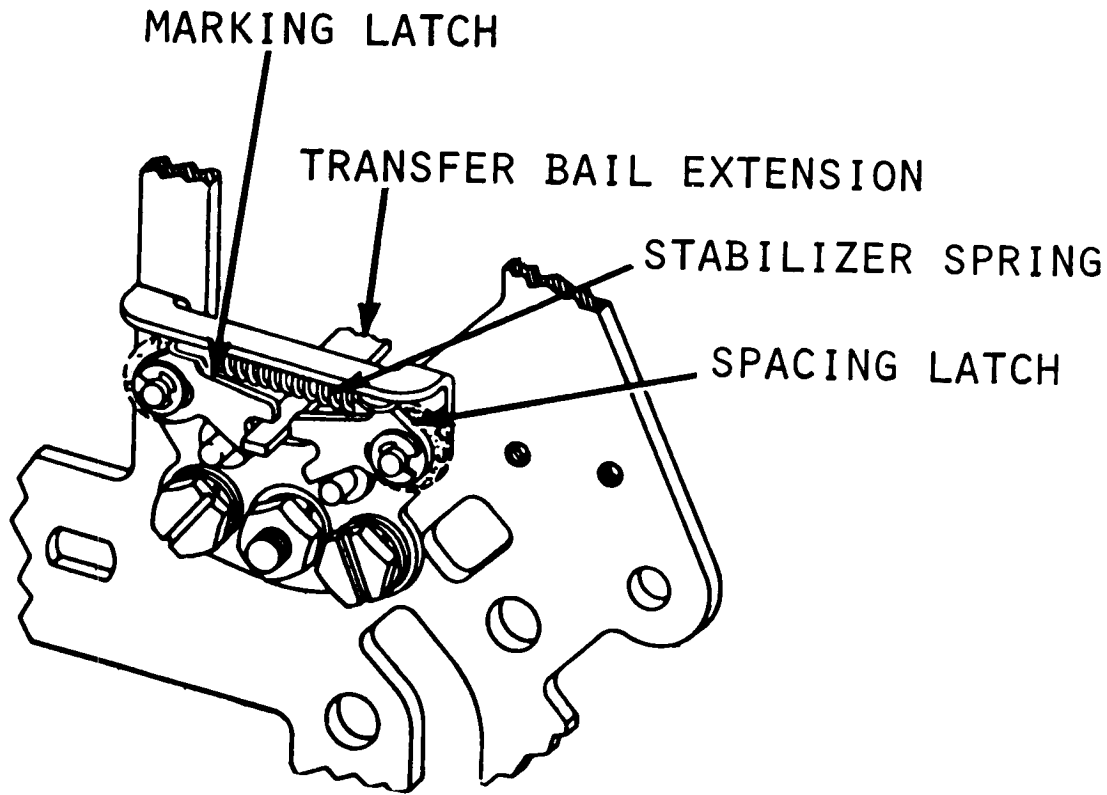

MOD 28 ASR-AN/UGC-6K- TRANSFER BAIL STABILIZER

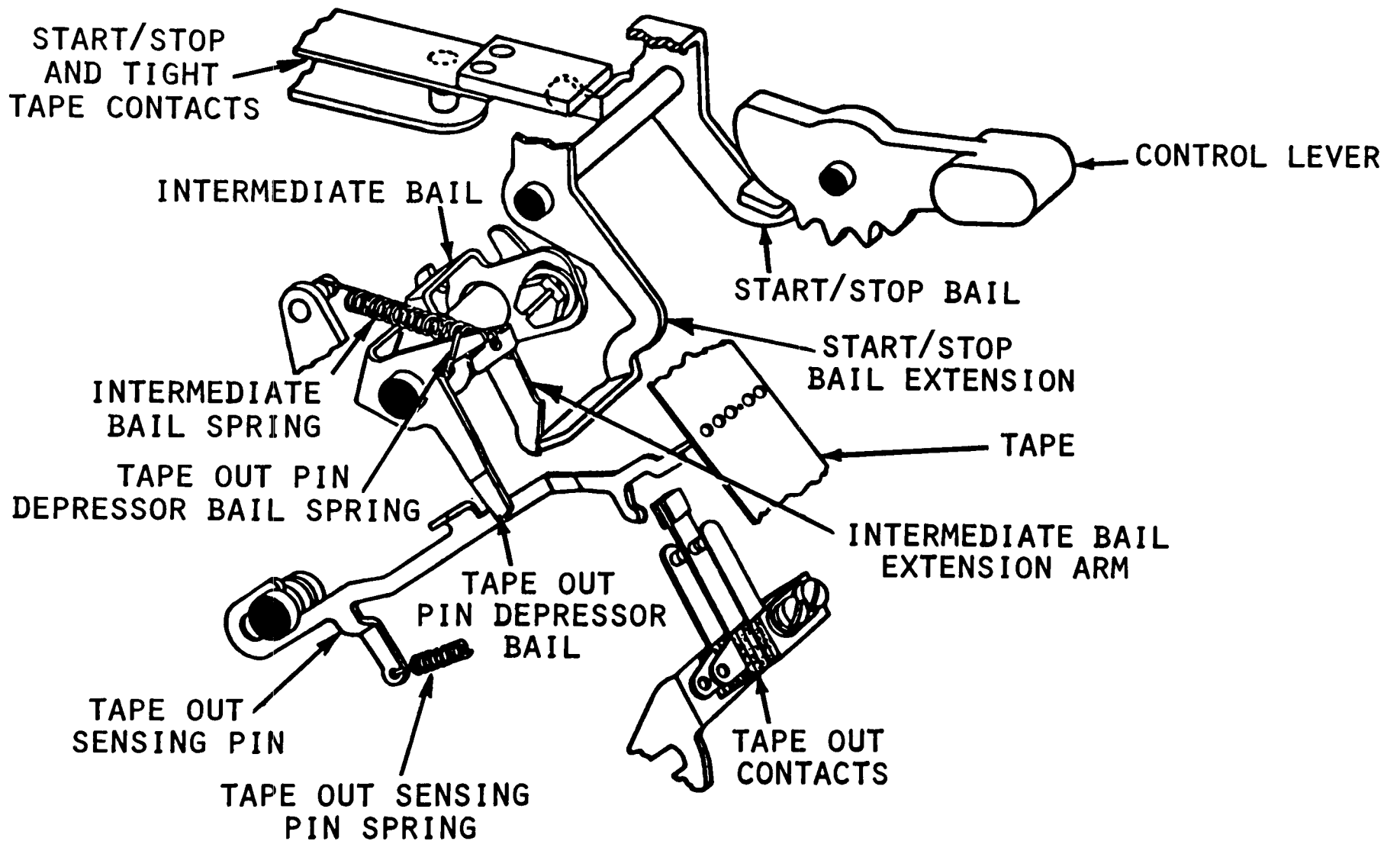

121

MOD 28 ASR-AN/UGC-6K- START/STOP MECHANISM & TAPE OUT SENSING

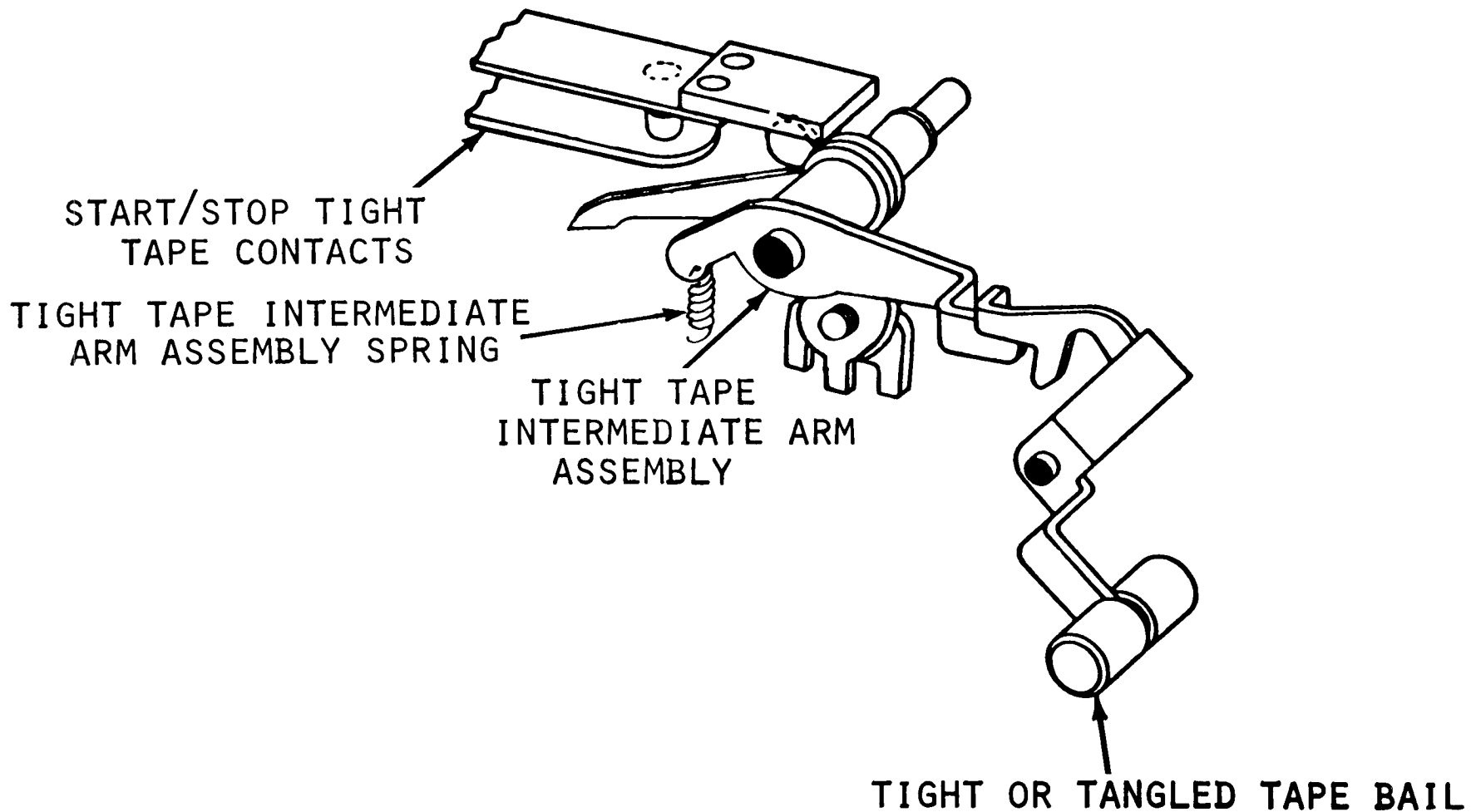

122

MOD 28 ASR-AN/UGC-6K- TIGHT OR TANGLED TAPE

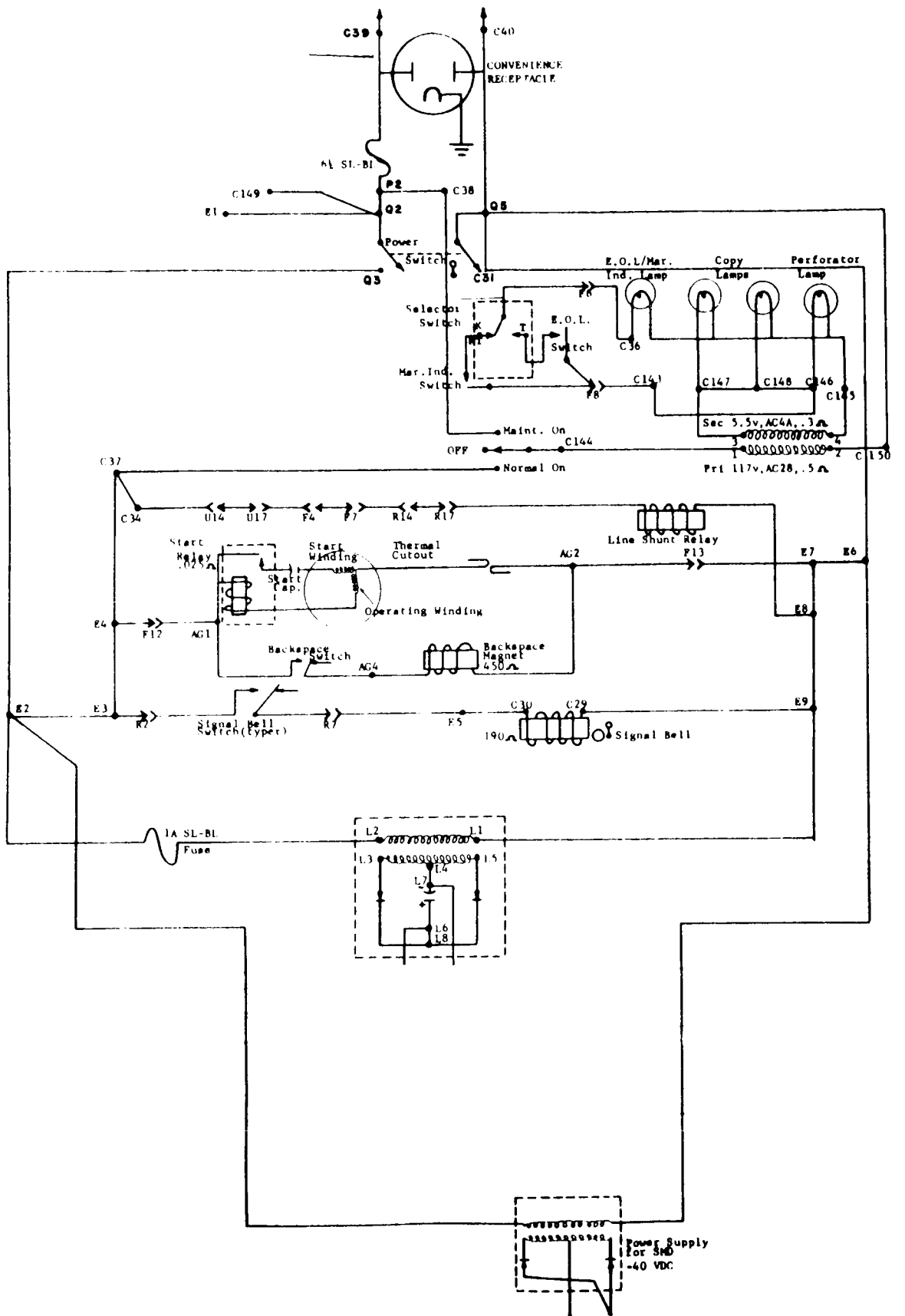

MOD 28 ASR-AN/UGC-6K AC CIRCUITS

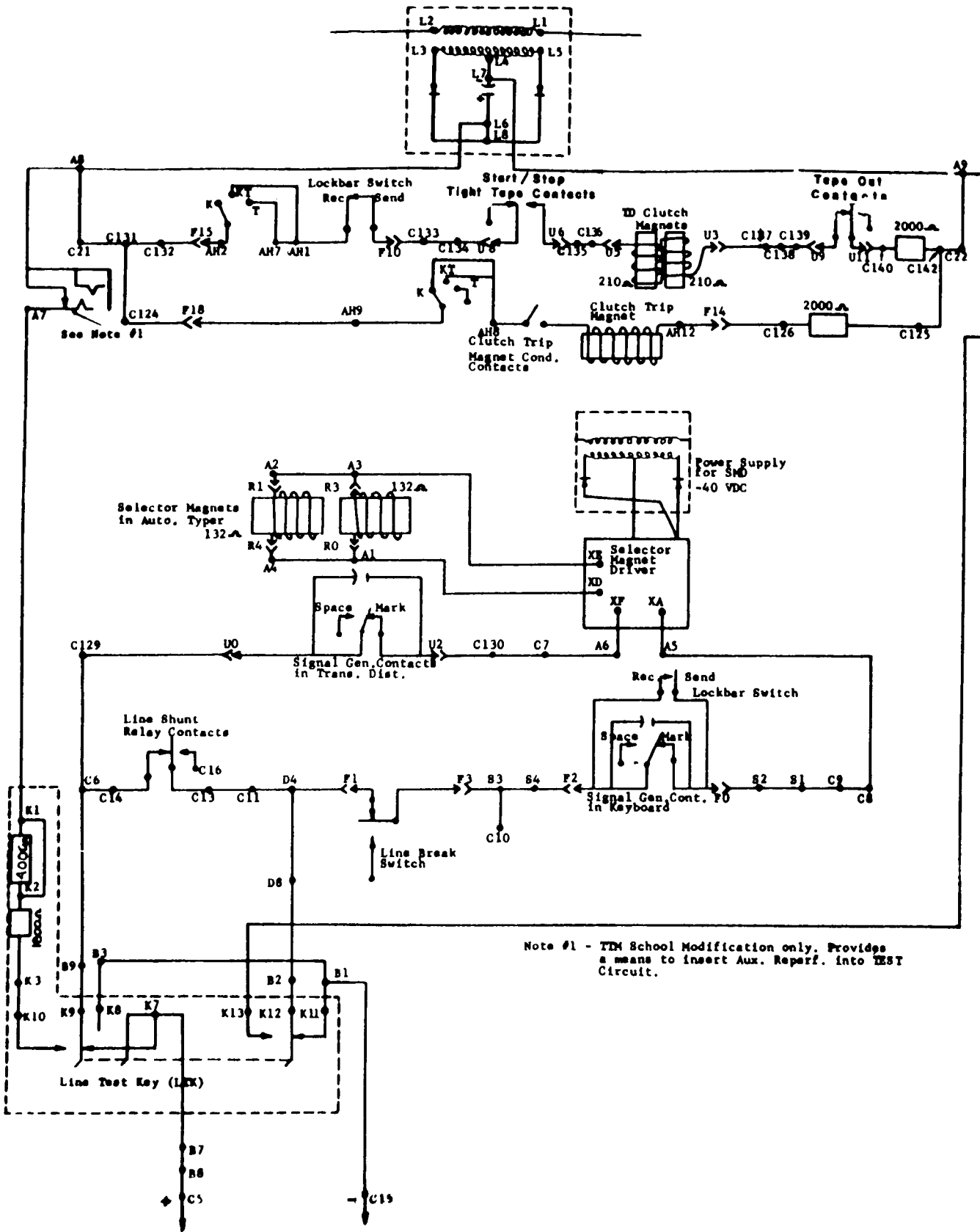

MOD 28 ASR-AN/UGC-6K DC CIRCUITS

6-3-1D

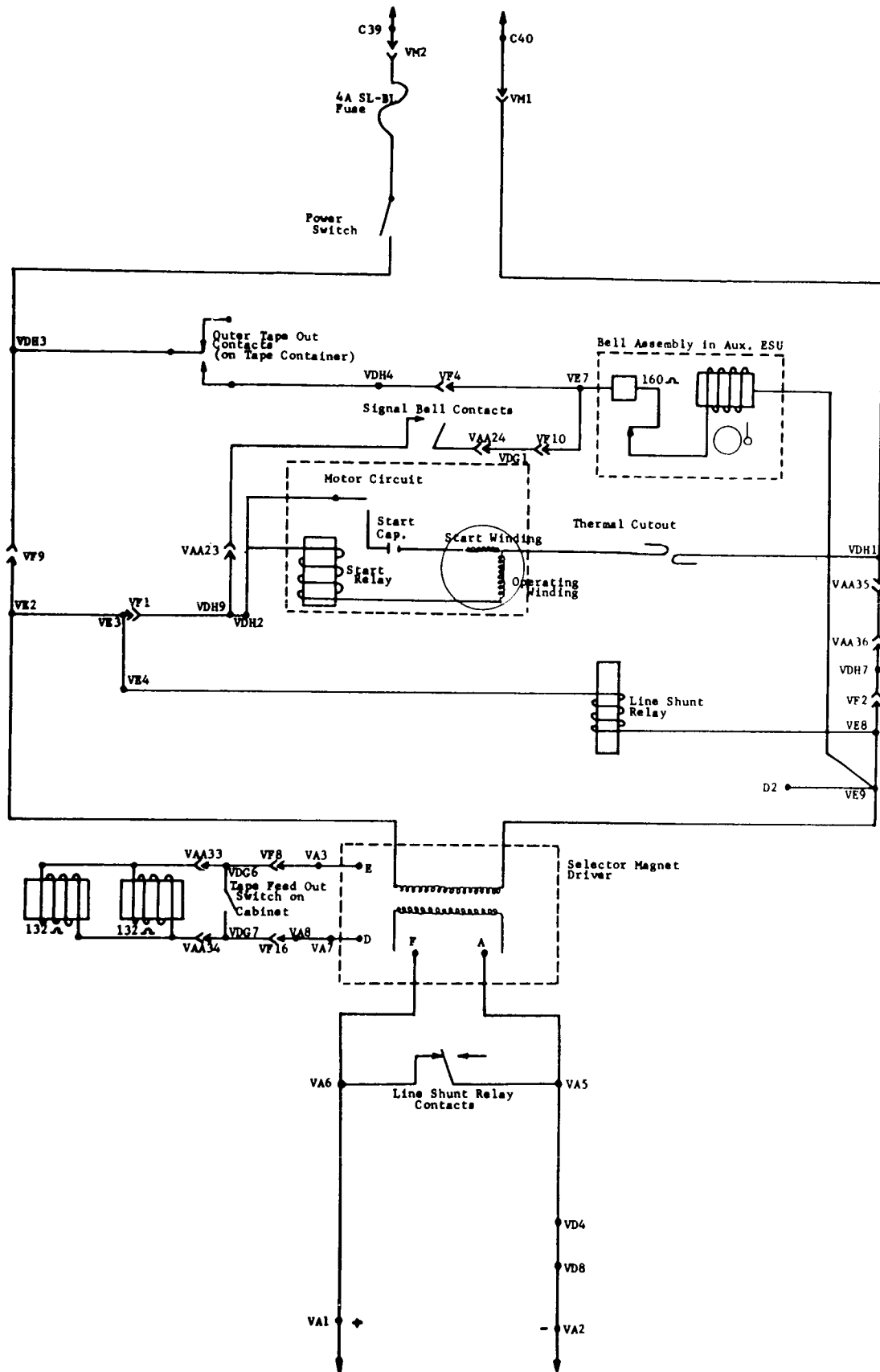

MOD 28 ASR-AN/UGC-6K AC AND DC CIRCUITS OF REPERFORATOR

6-4-1D

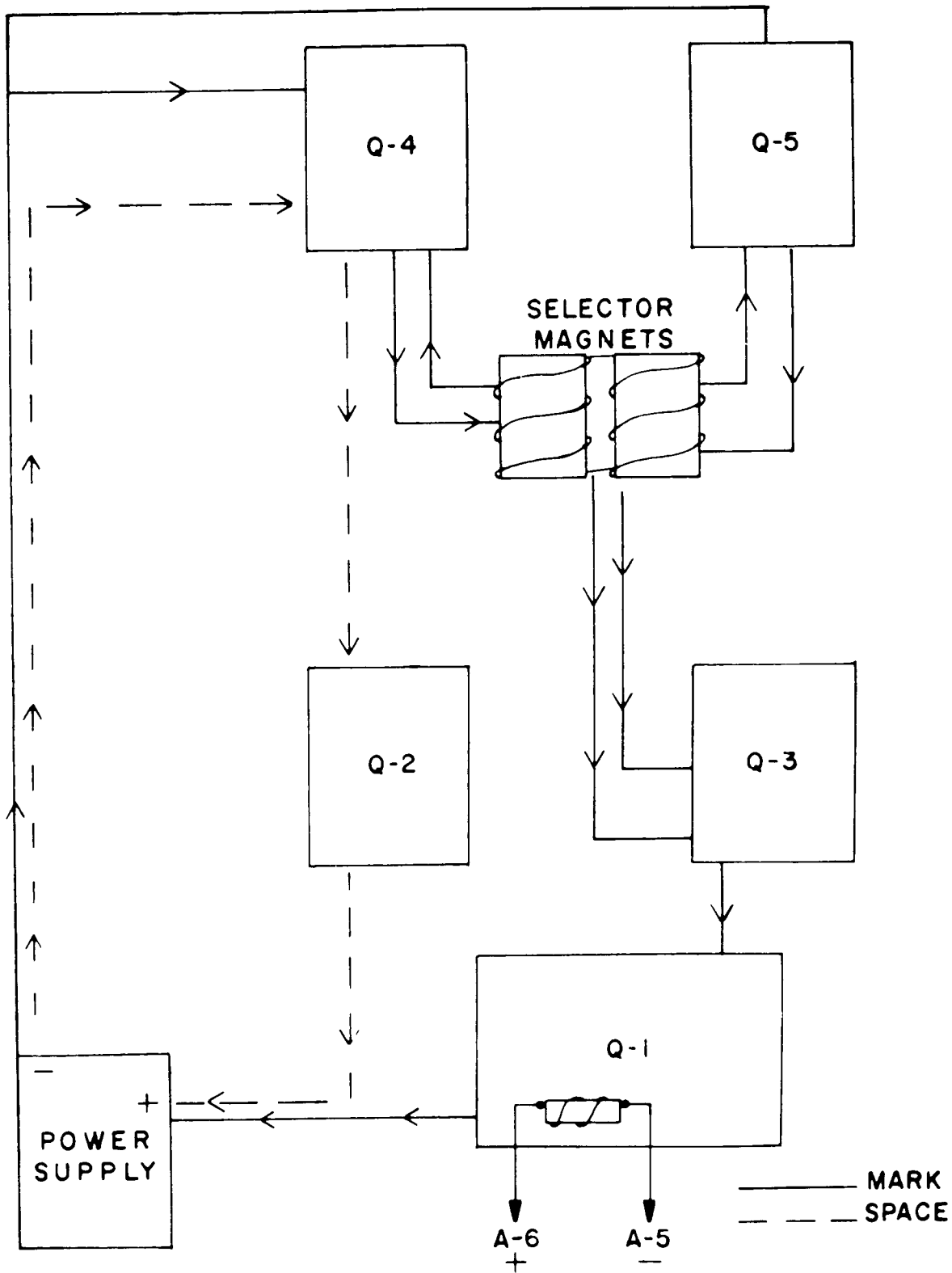

MOD 28 ASR-AN/UGC-6K SMD

6-5-1D

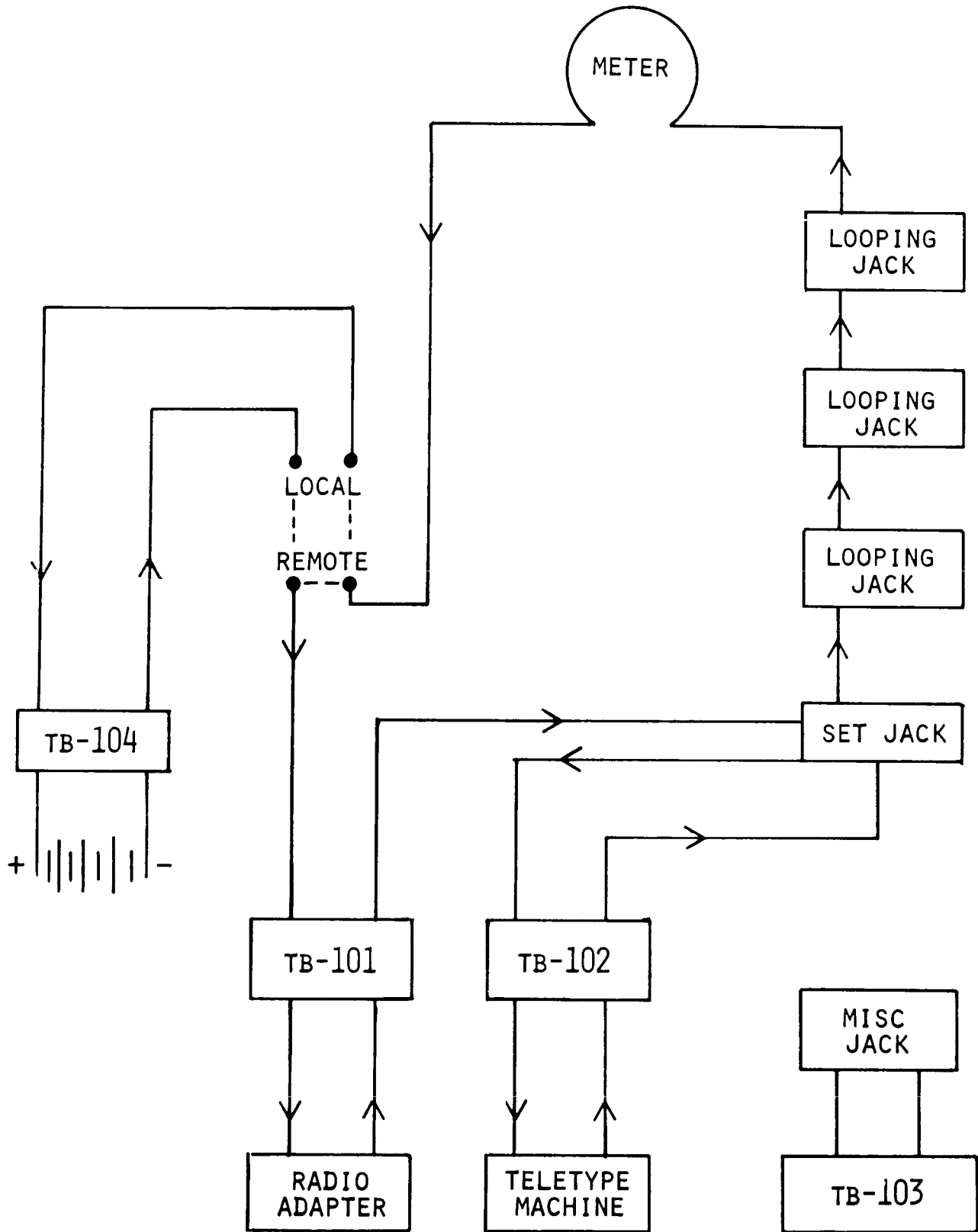

MOD 28 ASR-AN/UGC-6K- TELETYPE PANEL BLOCK DIAGRAM

6-6-1D

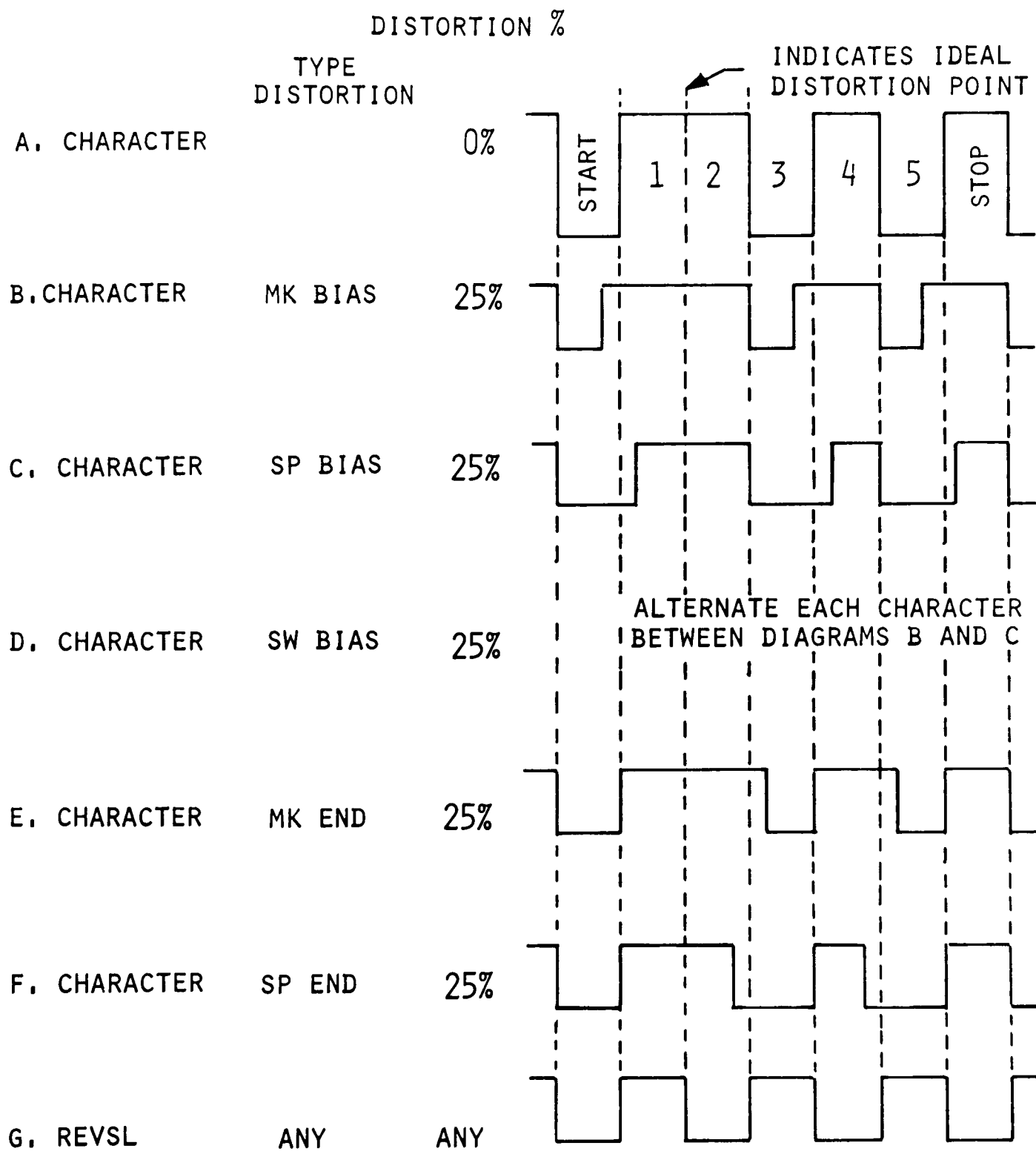

MOD 28 ASR-AN/UGC-6K TELETYPE DISTORTION

7-1-1D

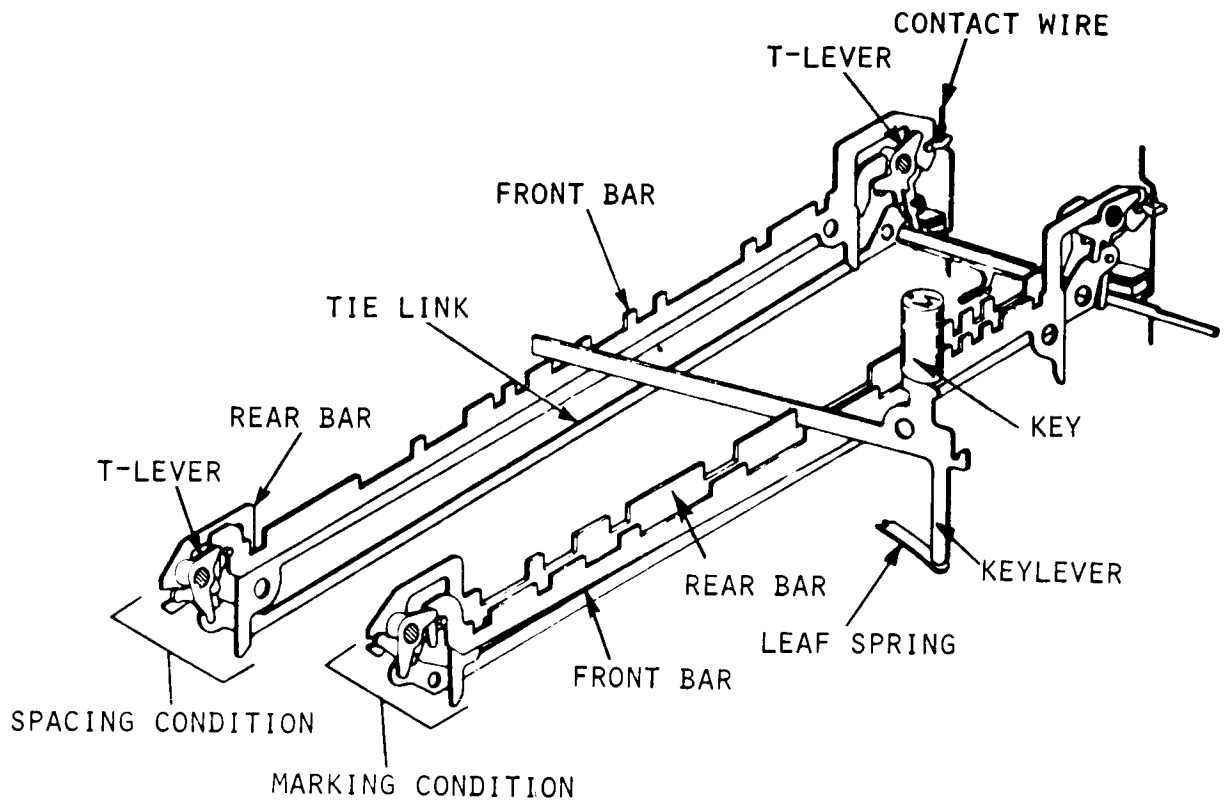

(LEFT FRONT VIEW)

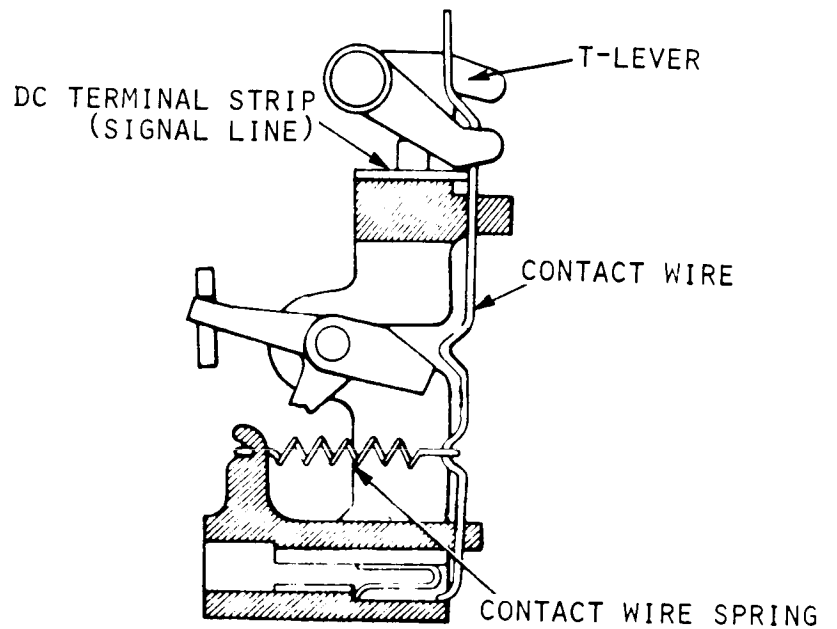

(FRONT VIEW)

MOD 28 ASR-AN/UGC -20- CODEBAR MECHANISM

8-2-1D

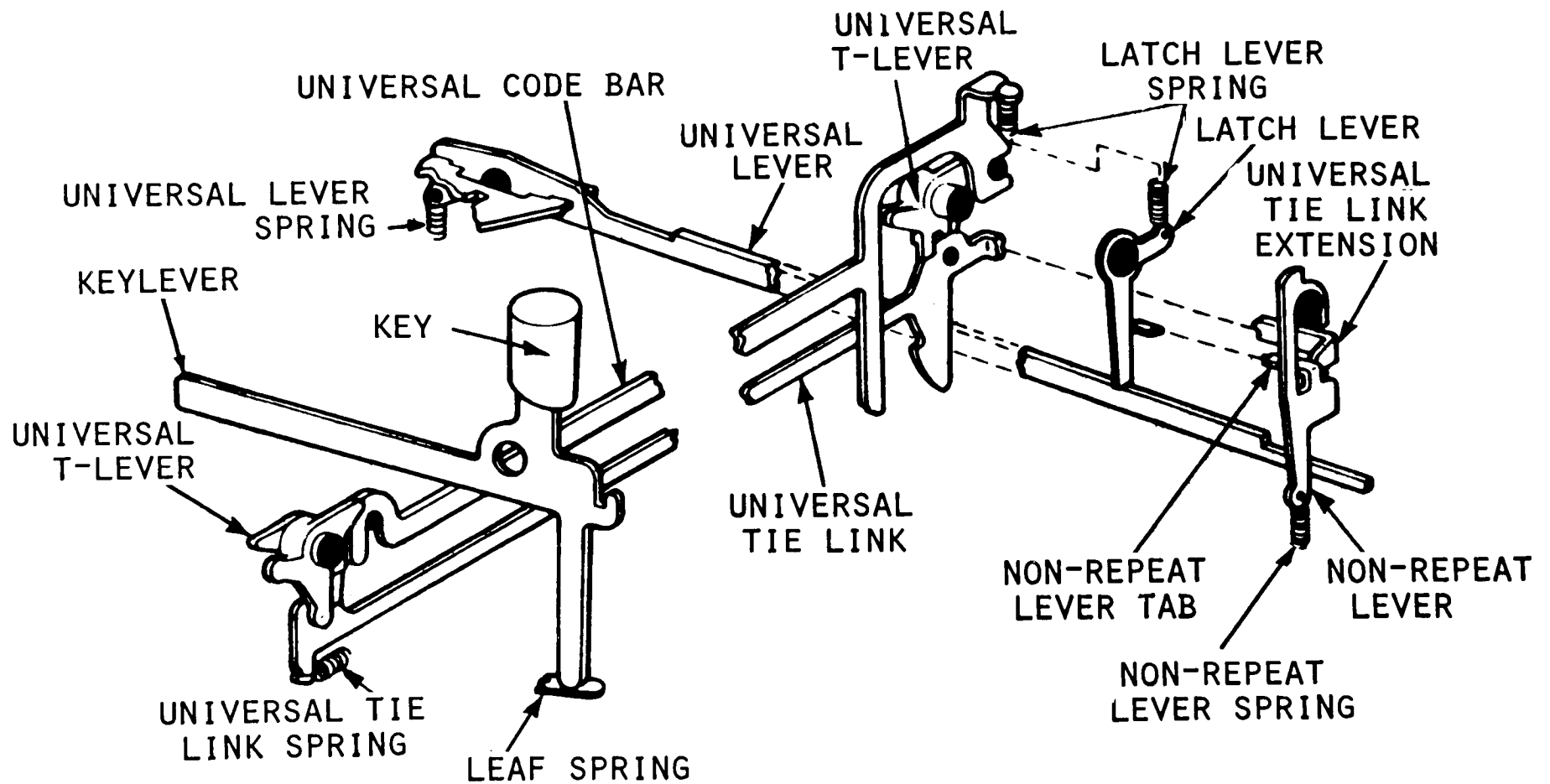

MOD 28 ASR-AN/UGC-20- UNIVERSAL MECHANISM (LEFT FRONT VIEW)

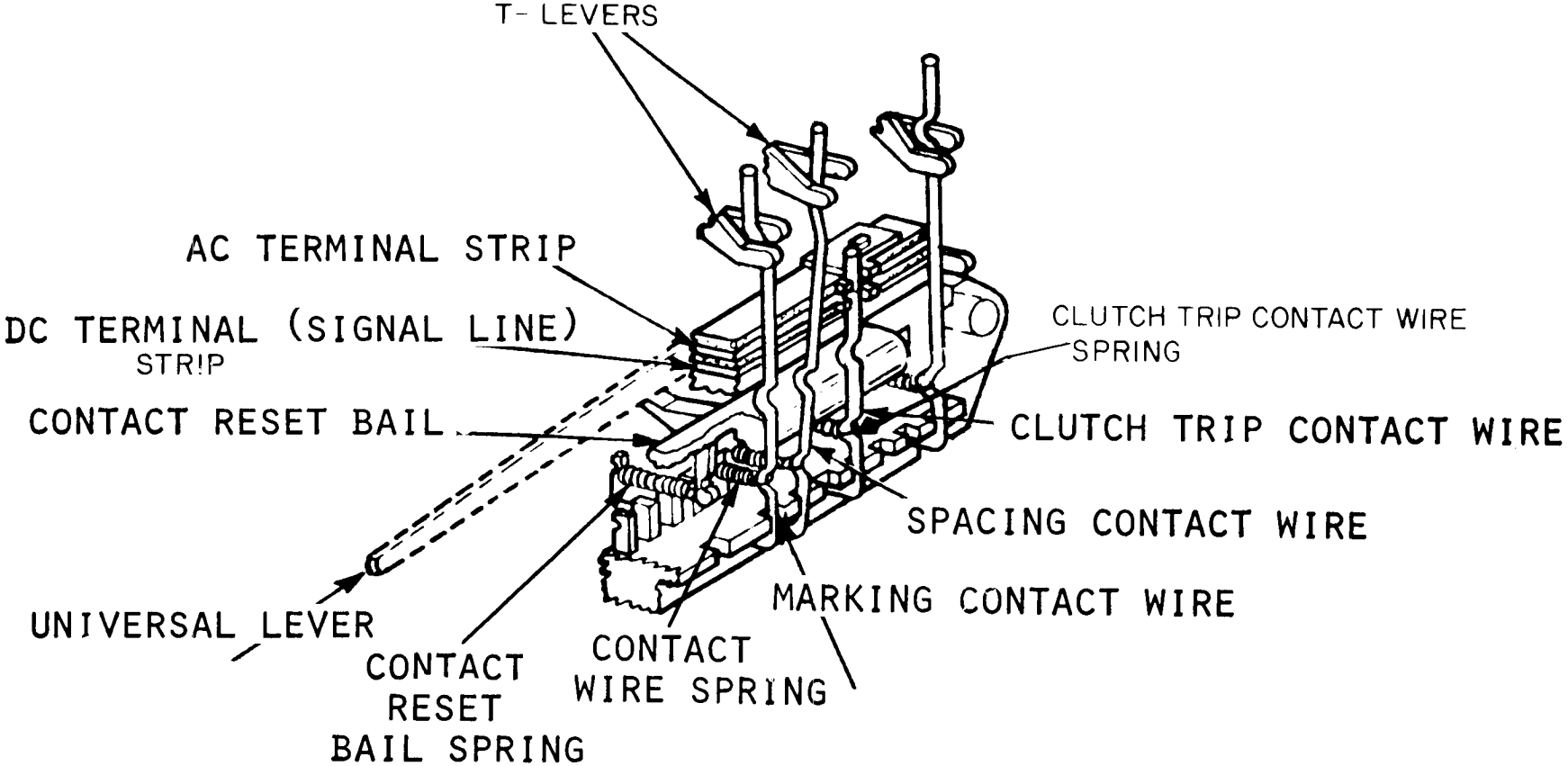

MOD 28 ASR-AN/UGC-20- CONTACT MECHANISM (RIGHT FRONT VIEW)

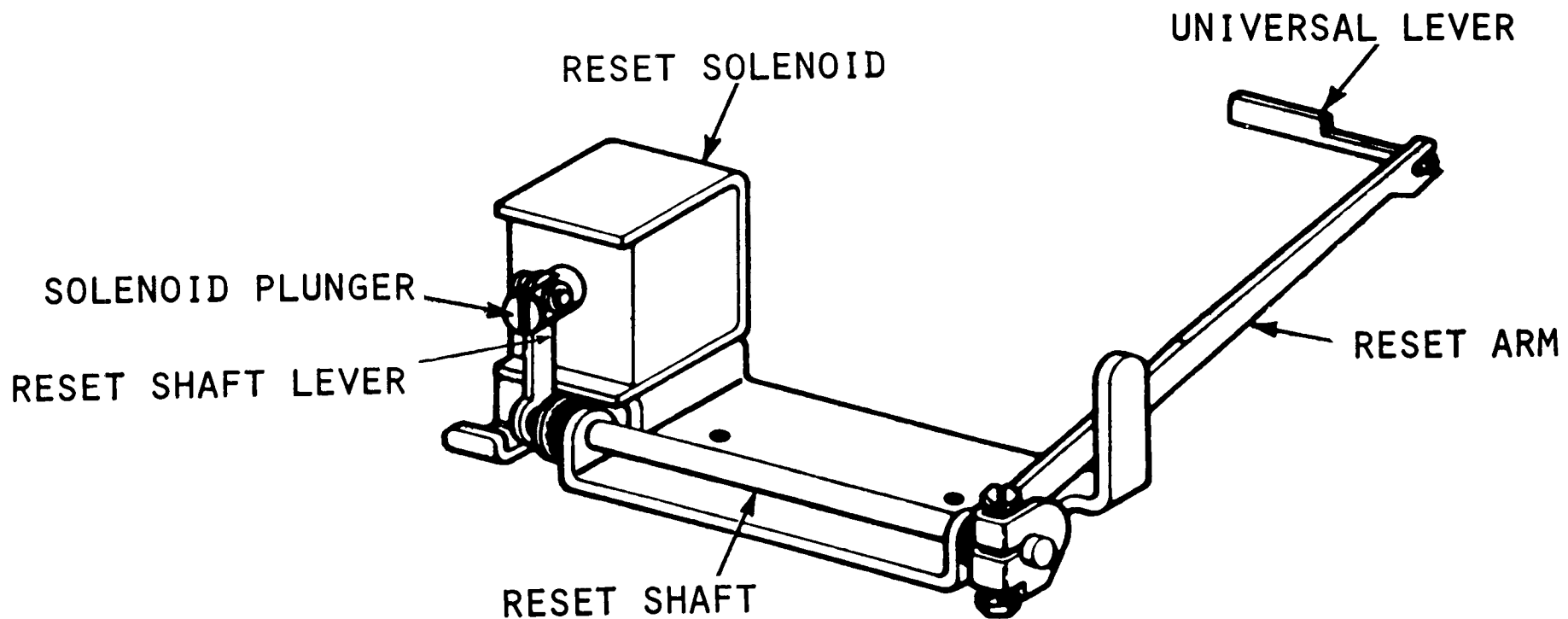

MOD 28 ASR-AN/UGC-20- RESET MECHANISM #1 (LEFT FRONT VIEW)

RIGHT FRONT VIEW

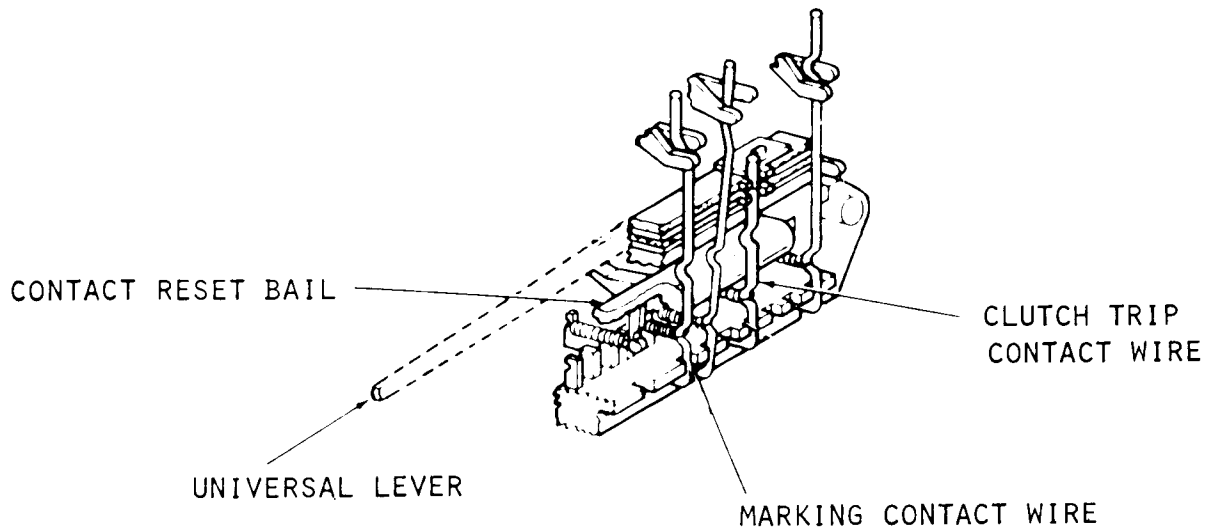

LEFT FRONT VIEW

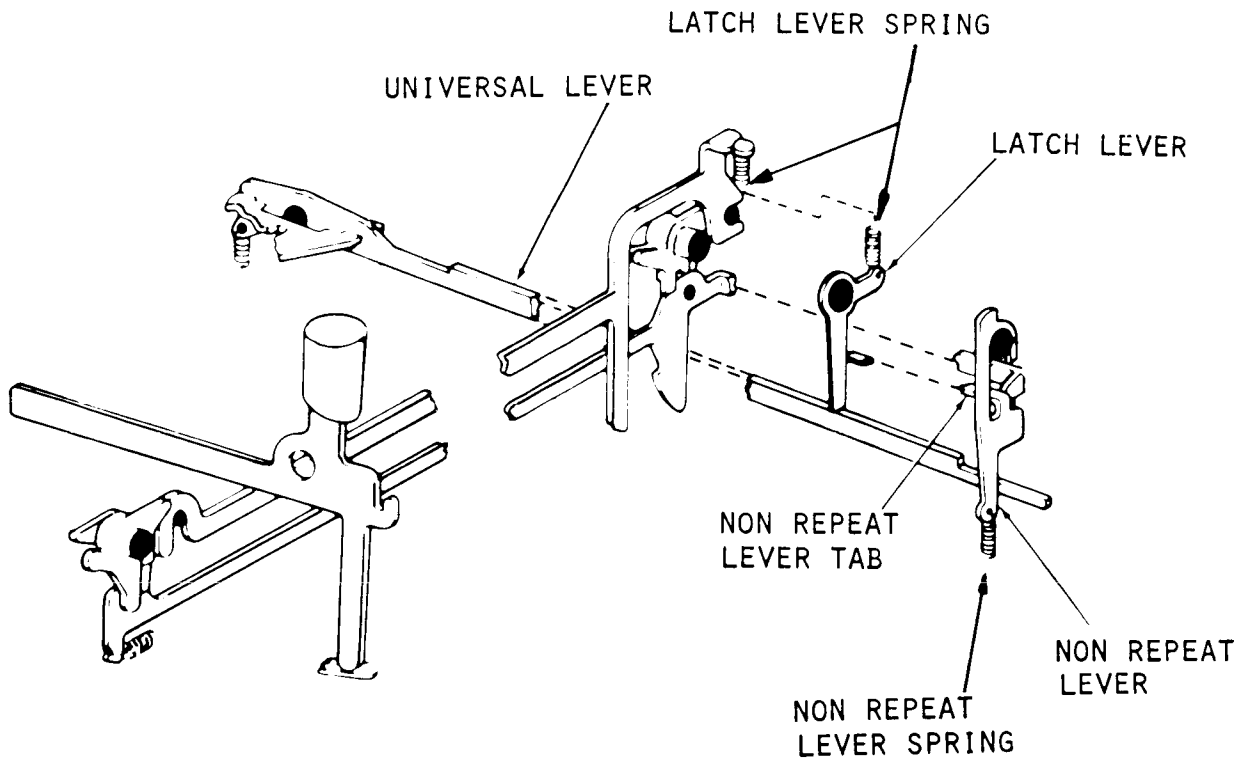

MOD 28 ASR-AN/UGC-20 RESET MECHANISM #2

8-2-5D

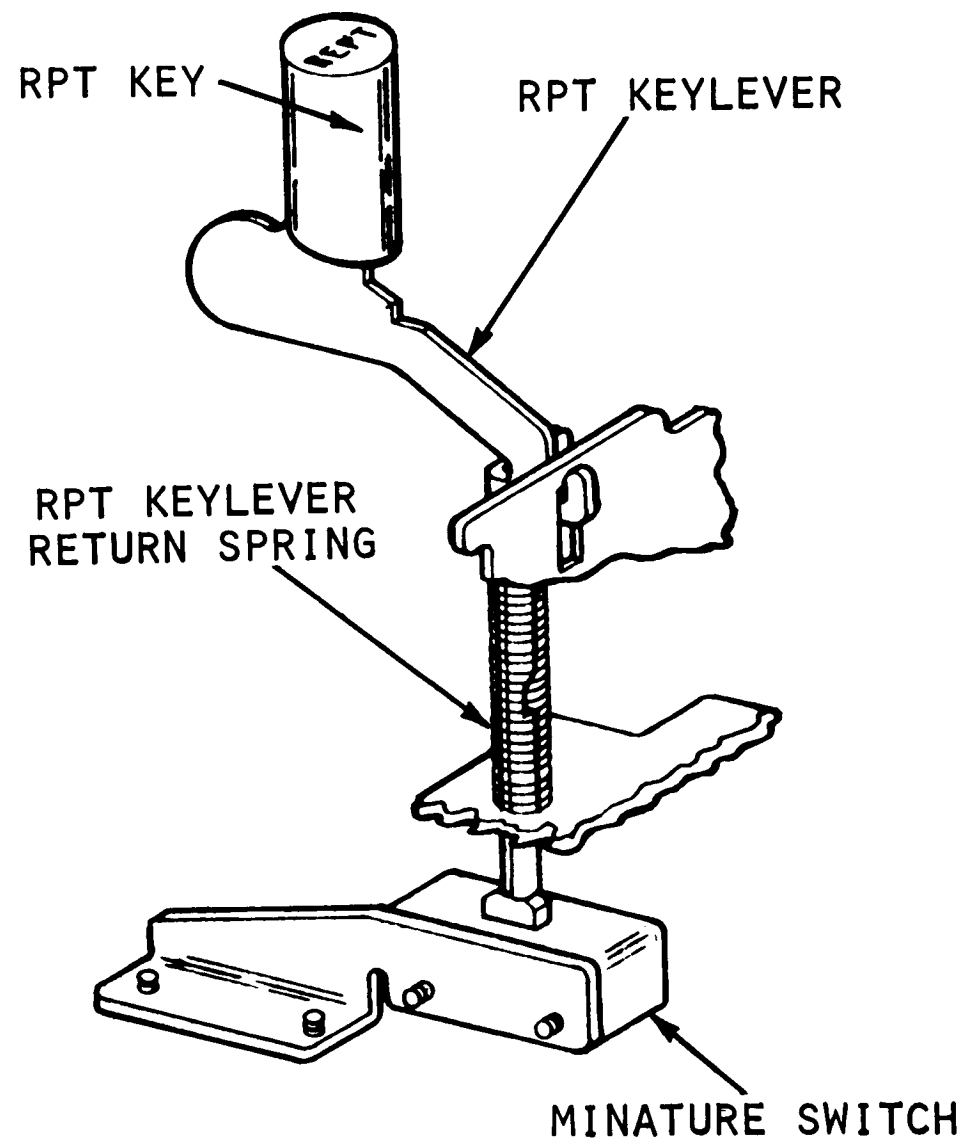

MOD 28 ASR-AN/UGC-20- REPEAT MECHANISM (LEFT FRONT VIEW)

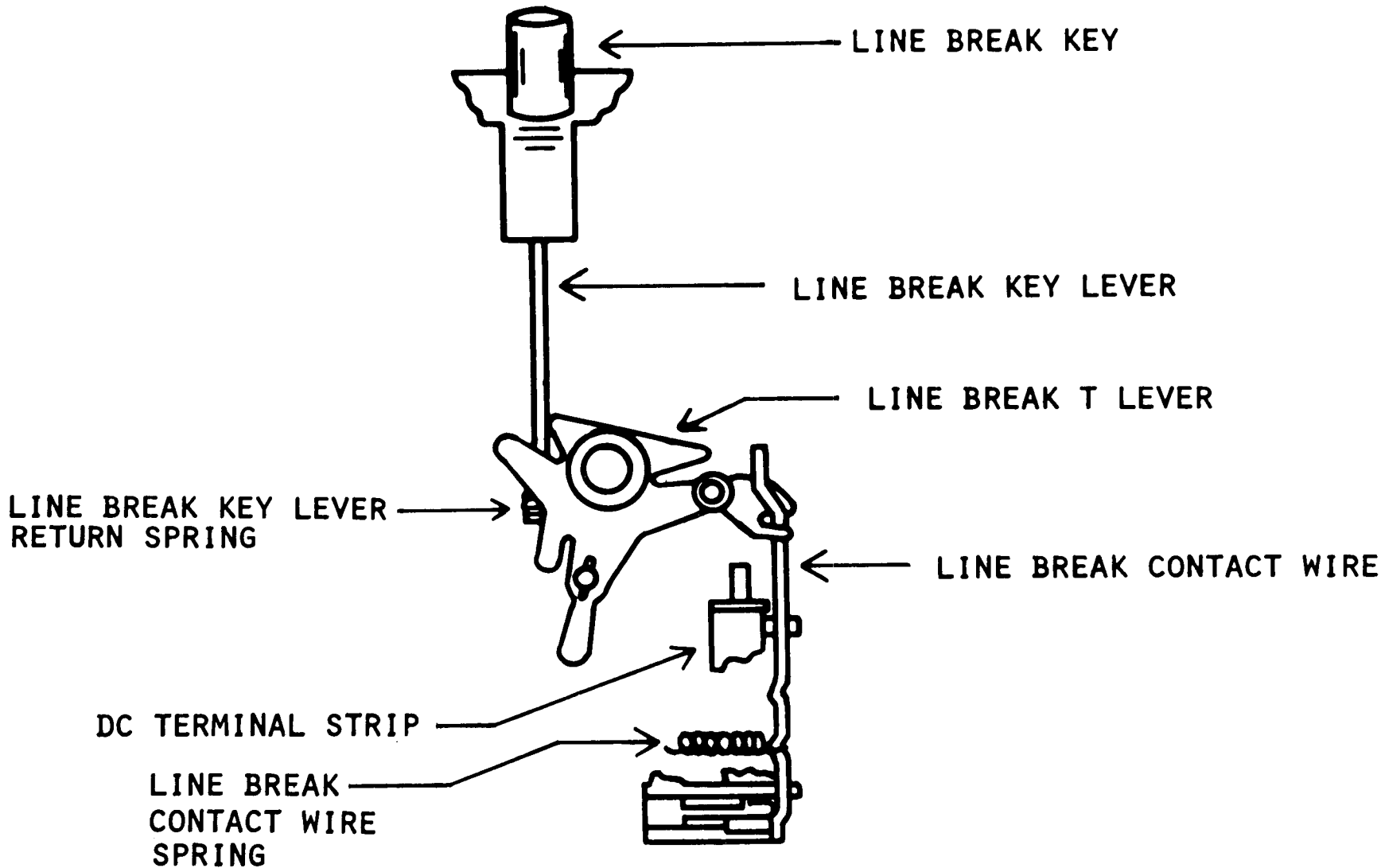

MOD 28 ASR-AN/UGC-20 LINE BREAK MECHANISM

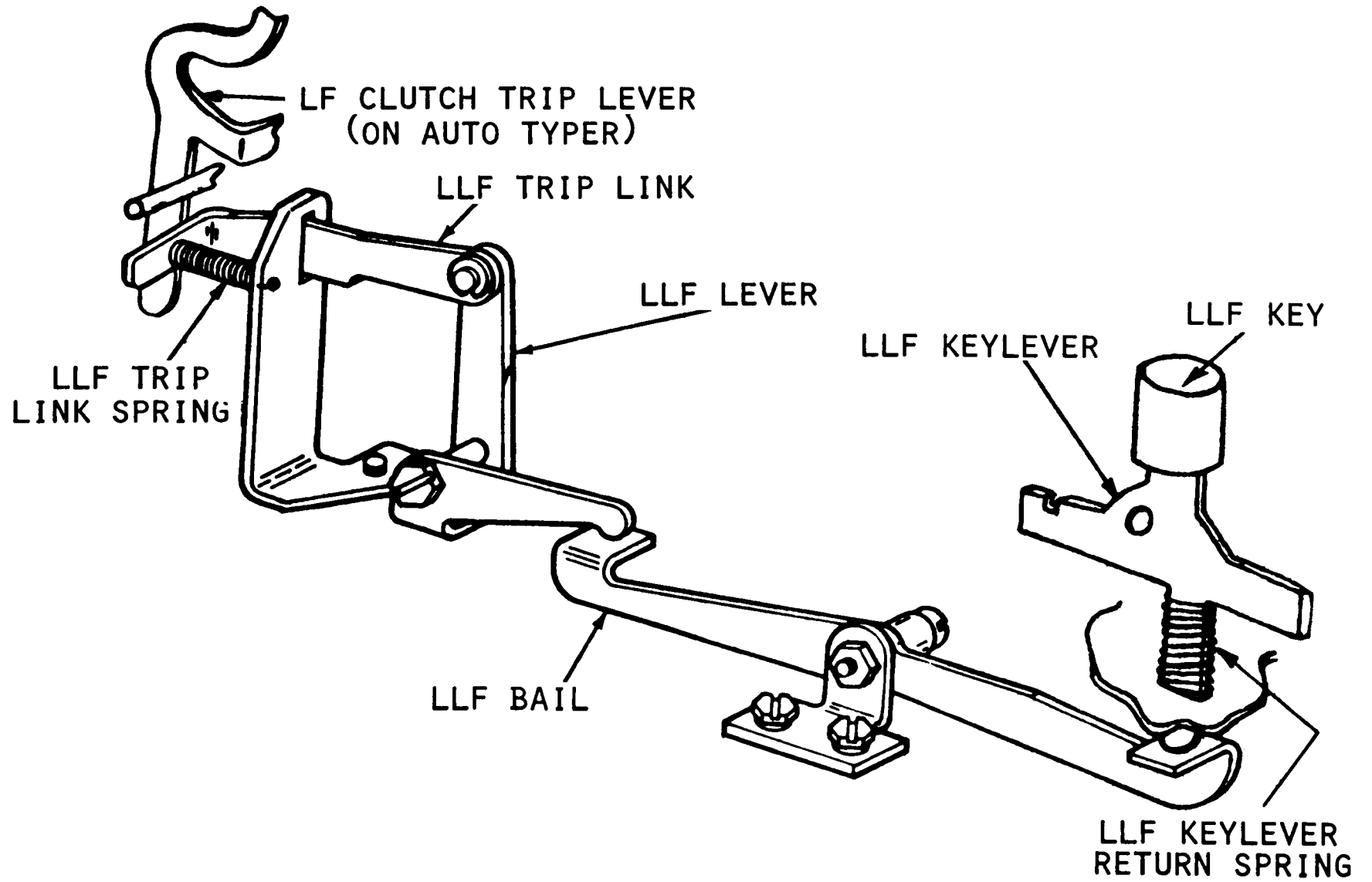

MOD 28 ASR-AN/UGC-20- LOCAL LINE FEED (LLF) (LEFT VIEW)

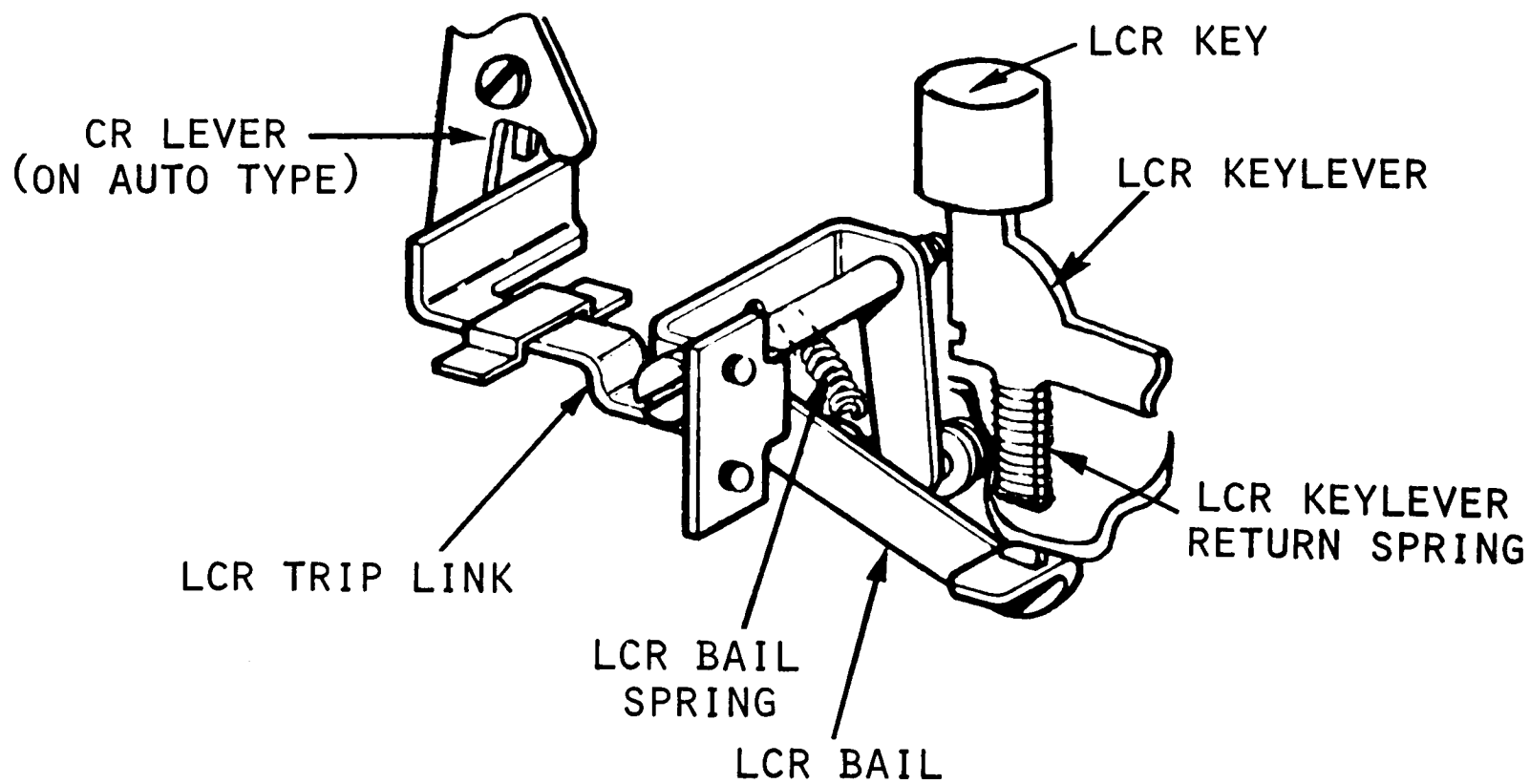

MOD 28 ASR-AN/UGC-20- LOCAL CARRIAGE RETURN (LCR) (LEFT VIEW)

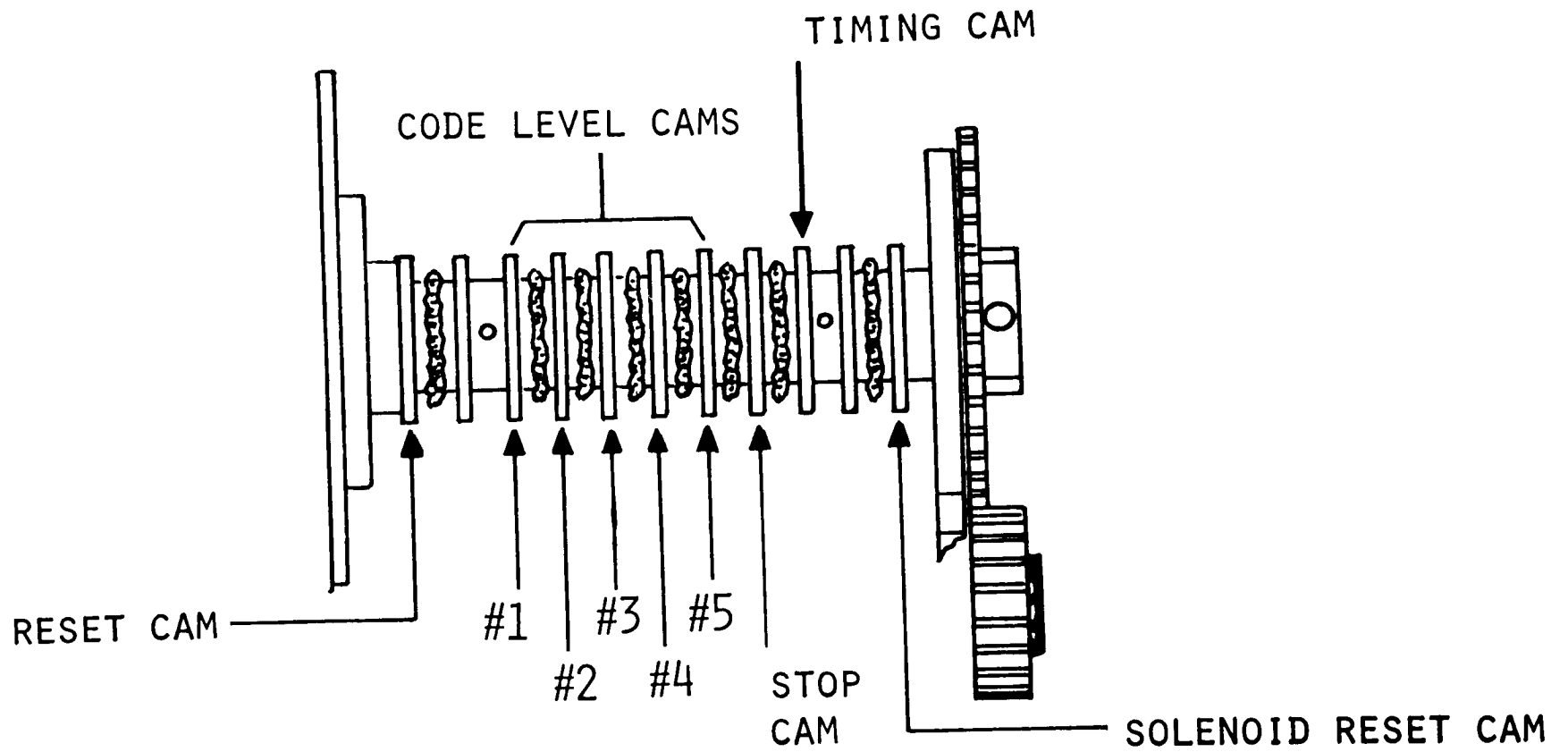

MOD 28 ASR-AN/UGC-20 DISTRIBUTOR CAM SLEEVE

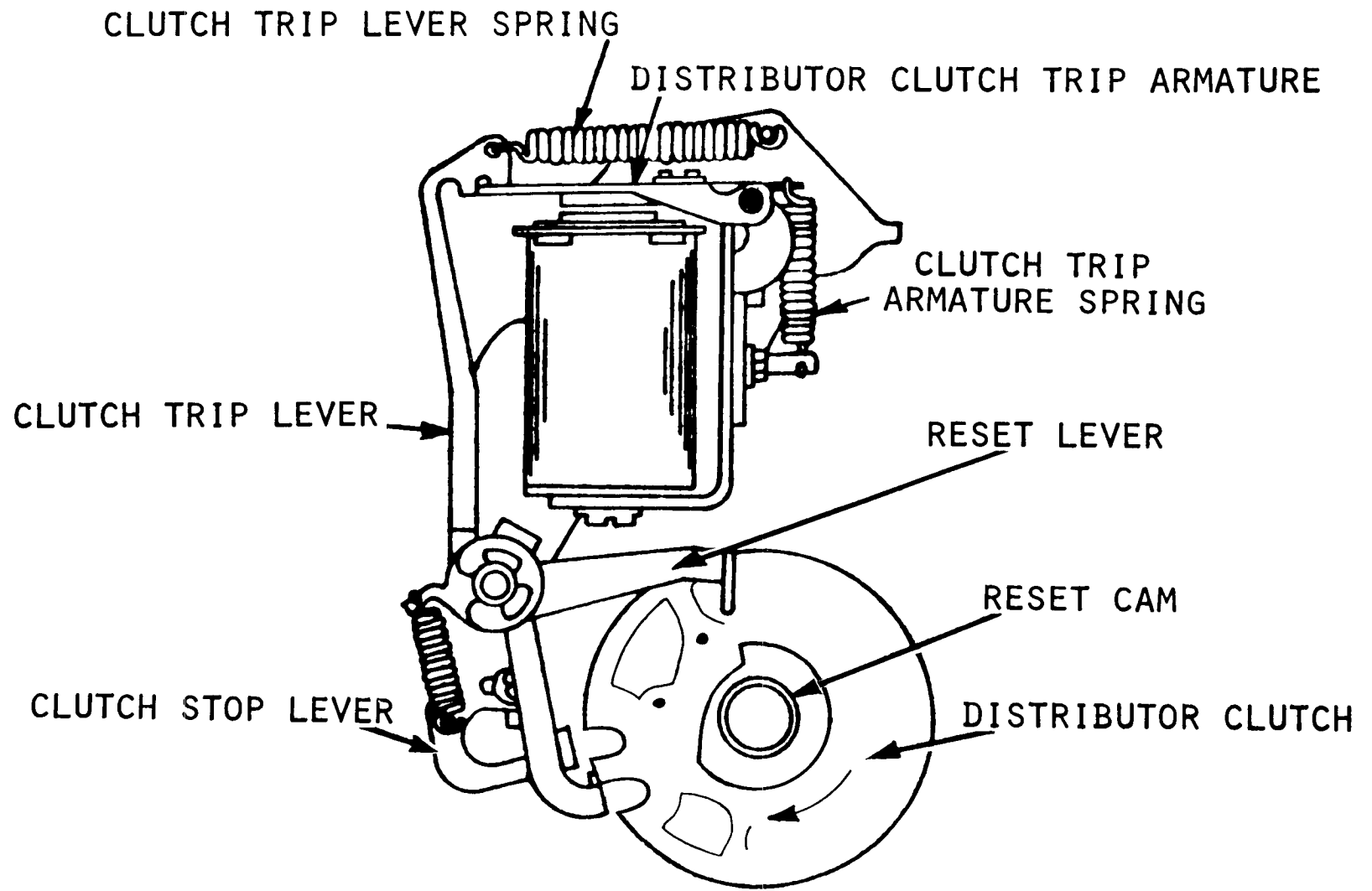

139

MOD 28 ASR-AN/UGC-20- DISTRIBUTOR CLUTCH TRIP MECHANISM (RIGHT VIEW)

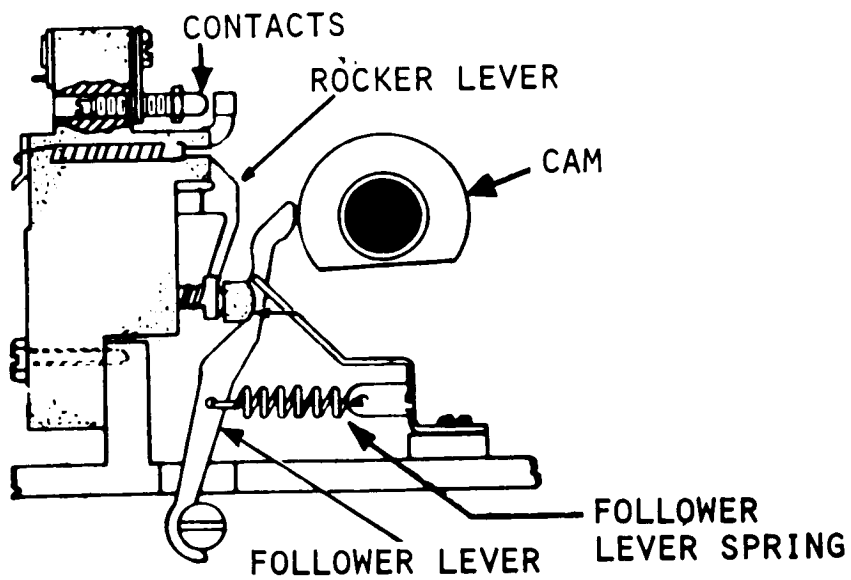
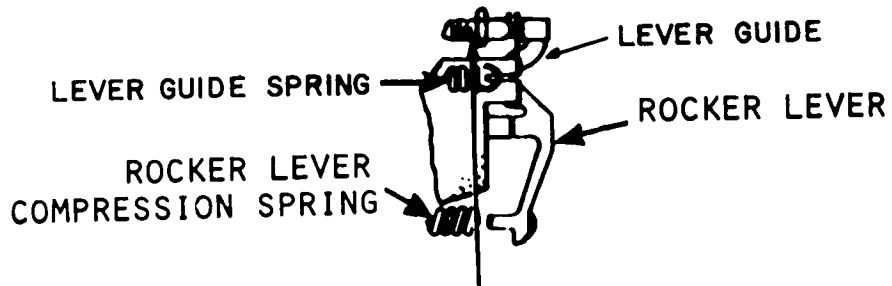

MOD 28 ASR-AN/UGC-20- DISTRIBUTOR MECHANISM (RIGHT SIDE VIEW)

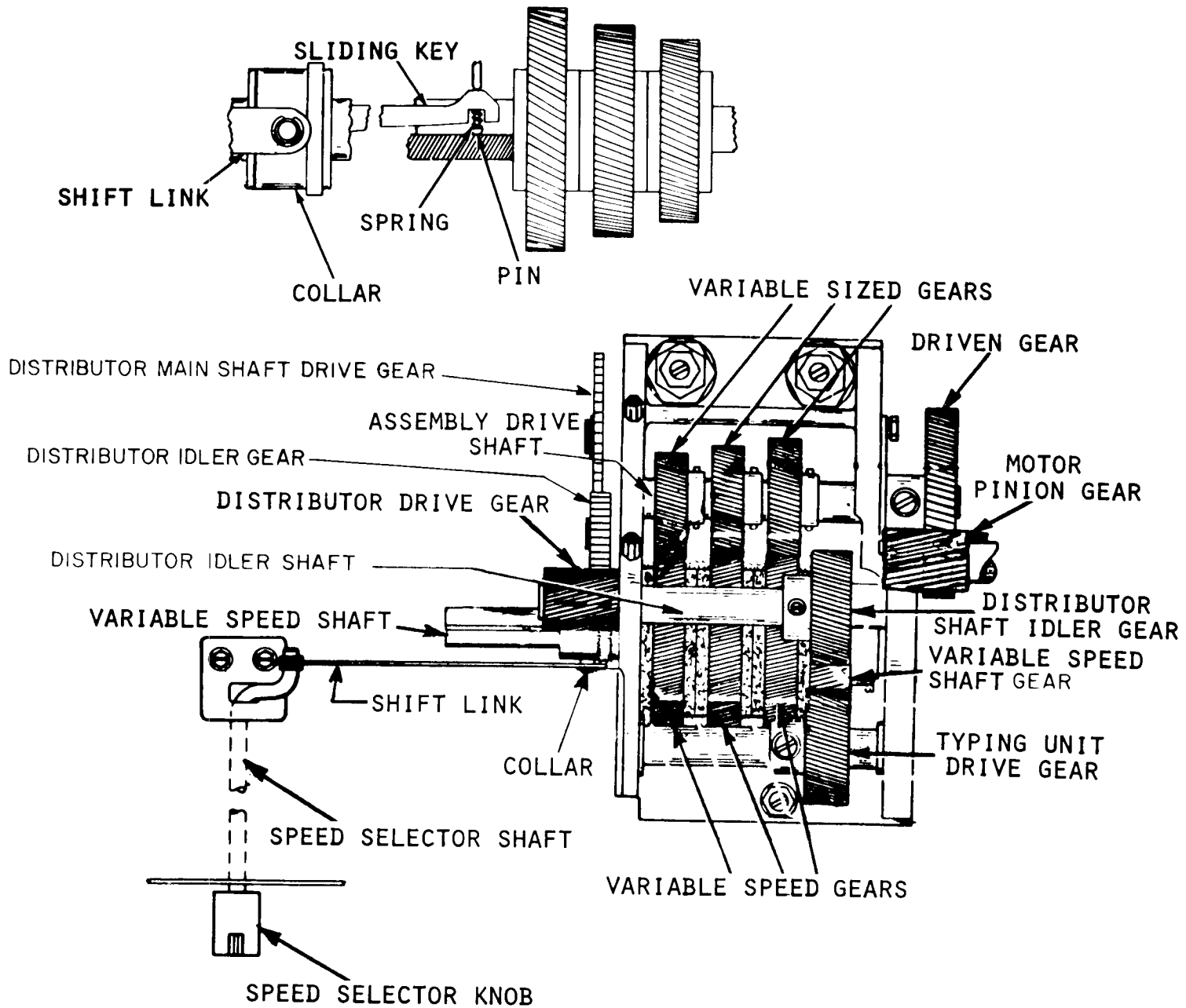

MOD 28 ASR-AN/UGC-20- 3-SPEED GEAR MECHANISM (TOP VIEW)

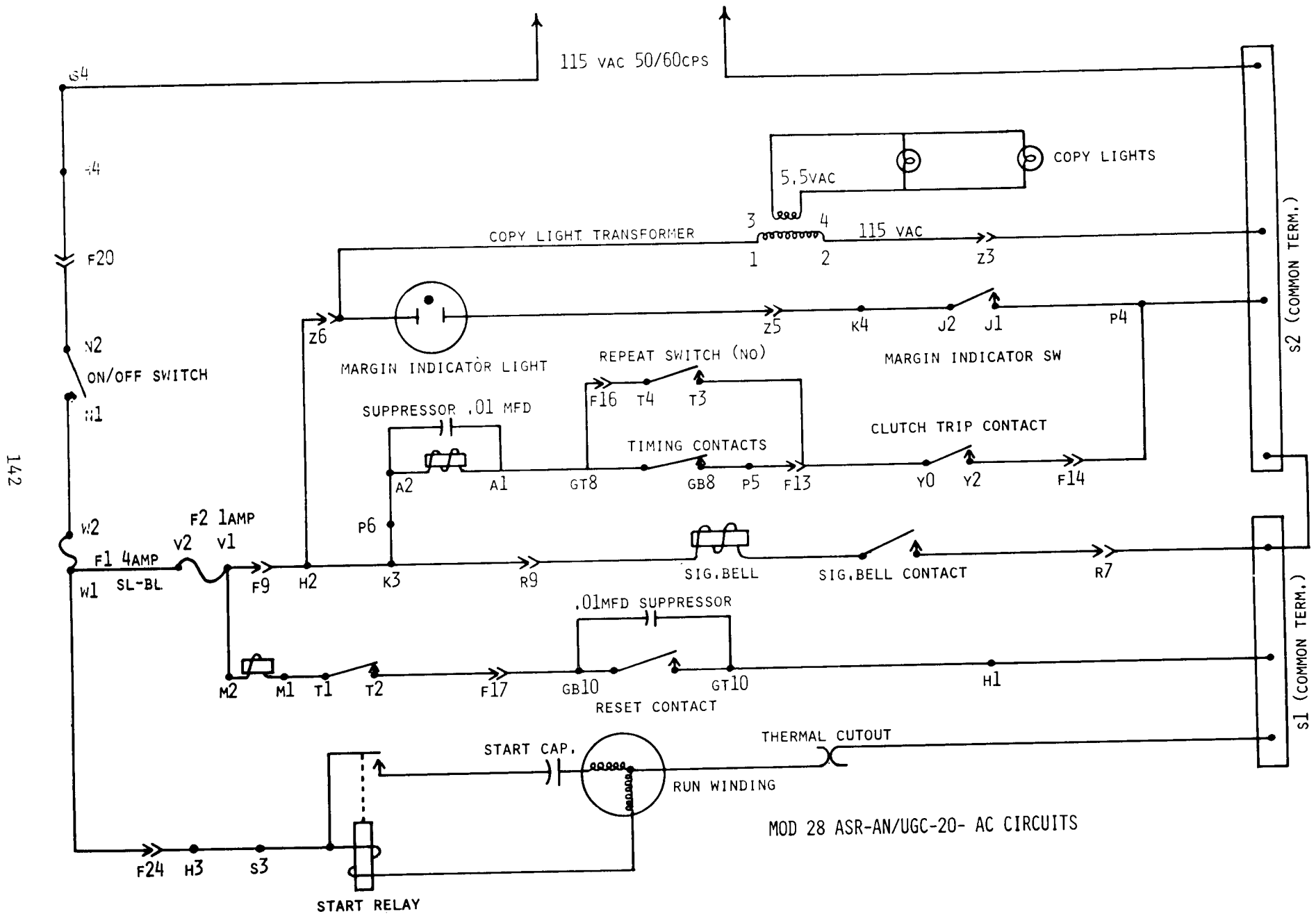

142

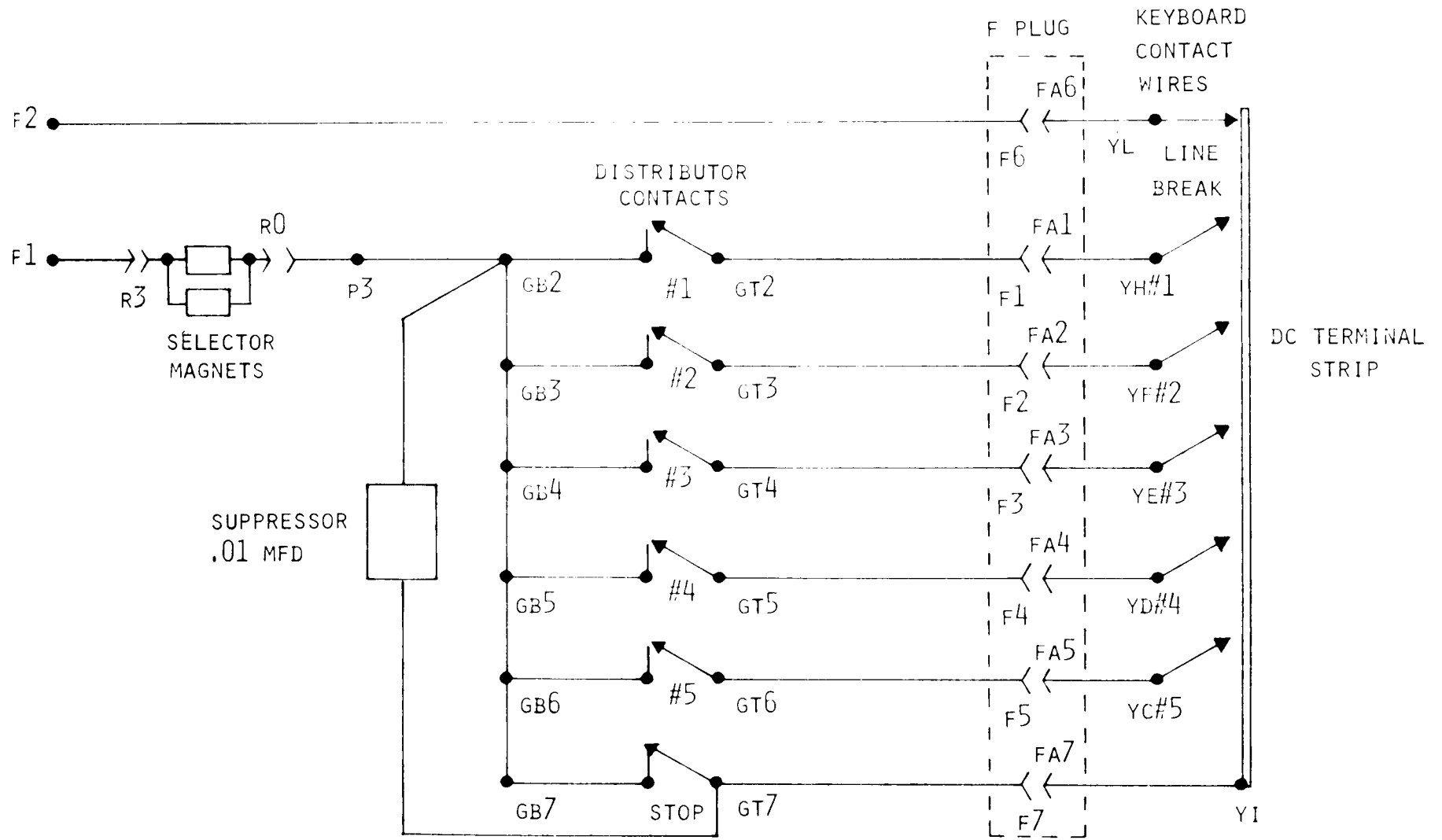

MOD 28 ASR-AN/UGC-20 DC CIRCUITS

- C CABINET TERMINAL BLOCK
- DD MARGIN INDICATOR LAMP SOCKET
- DE MAINTENANCE AND COPY LIGHTS
- DF LIGHTING TRANSFORMER
- DG COPY LIGHT SWITCH
- VT REPERFORATOR POWER SWITCH
- VU REPERFORATOR TAPE FEED OUT SWITCH
- VH REPERFORATOR LINE SHUNT RELAY
- VJ REPERFORATOR SELECTOR MAGNET DRIVER

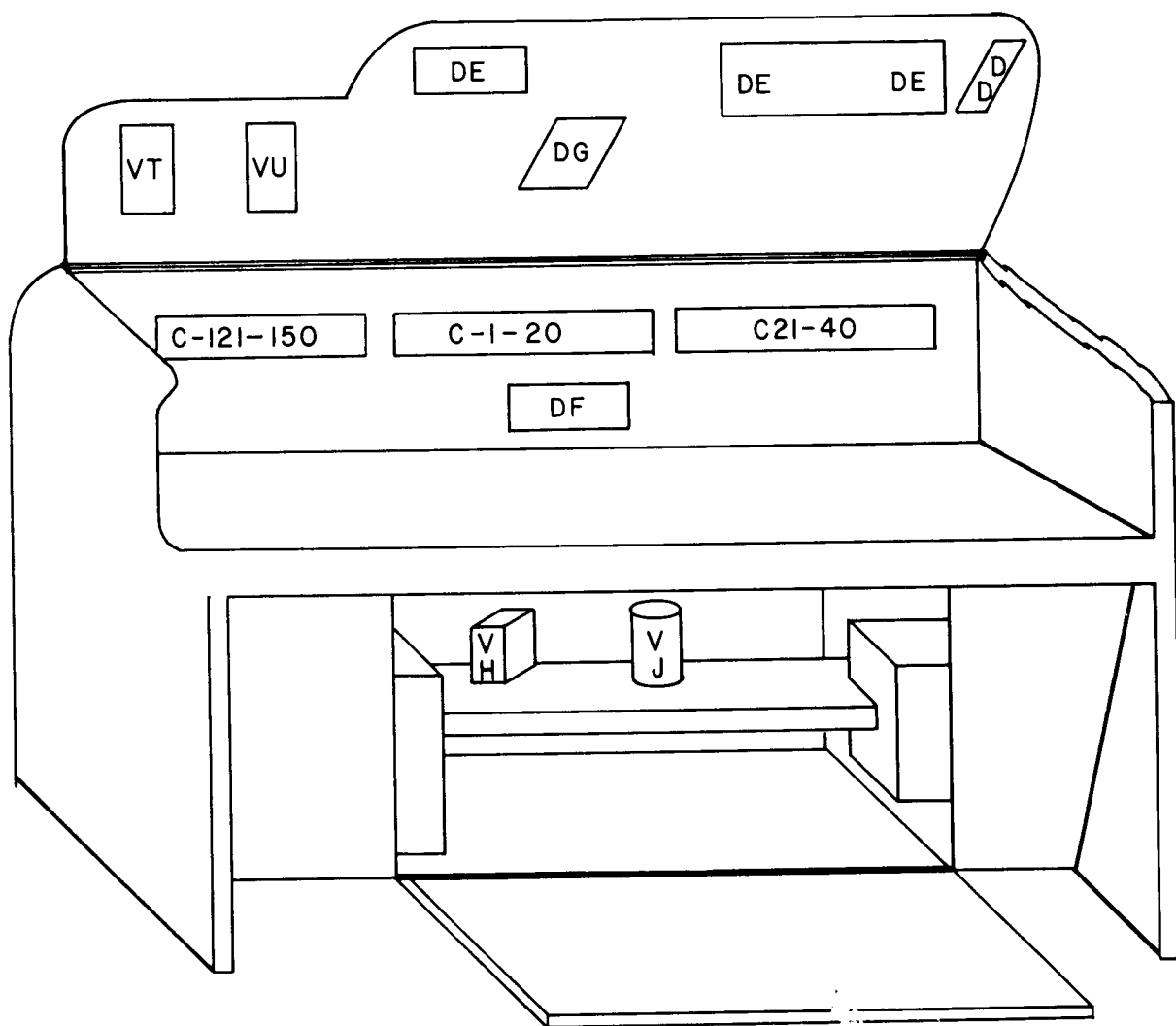

LOCATION OF ELECTRICAL COMPONENTS - CABINET

R AUTOMATIC TYPER CONNECTOR
 RA SELECTOR MAGNETS
 RB SIGNAL BELL CONTACTS

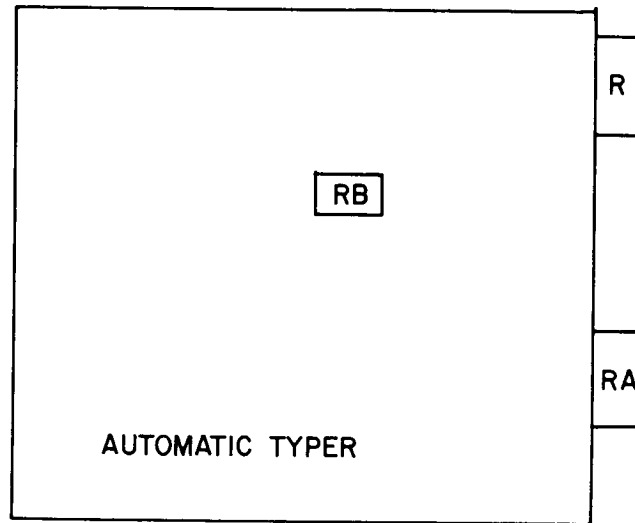

U TD BASE CONNECTOR
 UA TD SIGNAL GENERATOR CONTACTS
 UB TD CLUTCH MAGNETS
 UC START-STOP, TIGHT OR TANGLED TAPE CONTACT ASSEMBLY
 UD TAPE OUT CONTACT ASSEMBLY

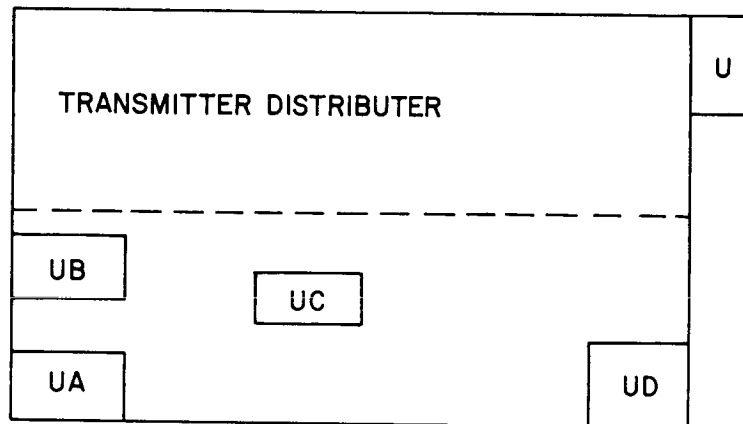

LOCATION OF ELECTRICAL COMPONENTS - AUTOMATIC TYPER AND TRANSMITTER DISTRIBUTOR

F KEYBOARD CONNECTOR
 AA SIGNAL GENERATOR CONTACTS
 AB LOCK BAR SWITCH
 AC AUXILIARY SWITCH
 AF END-OF-LINE/MARGIN INDICATOR SWITCH
 AG MOTOR TERMINAL BLOCK
 AH KEYBOARD TERMINAL BLOCK

AJ END-OF-LINE INDICATOR SWITCH
 AK SIGNAL LINE BREAK SWITCH
 AL MARGIN INDICATOR SWITCH
 AM BACK SPACE MAGNET (ON PERF)
 AN BACK SPACE SWITCH
 AP CLUTCH TRIP MAGNET
 AQ CLUTCH TRIP CONDITIONING SWITCH

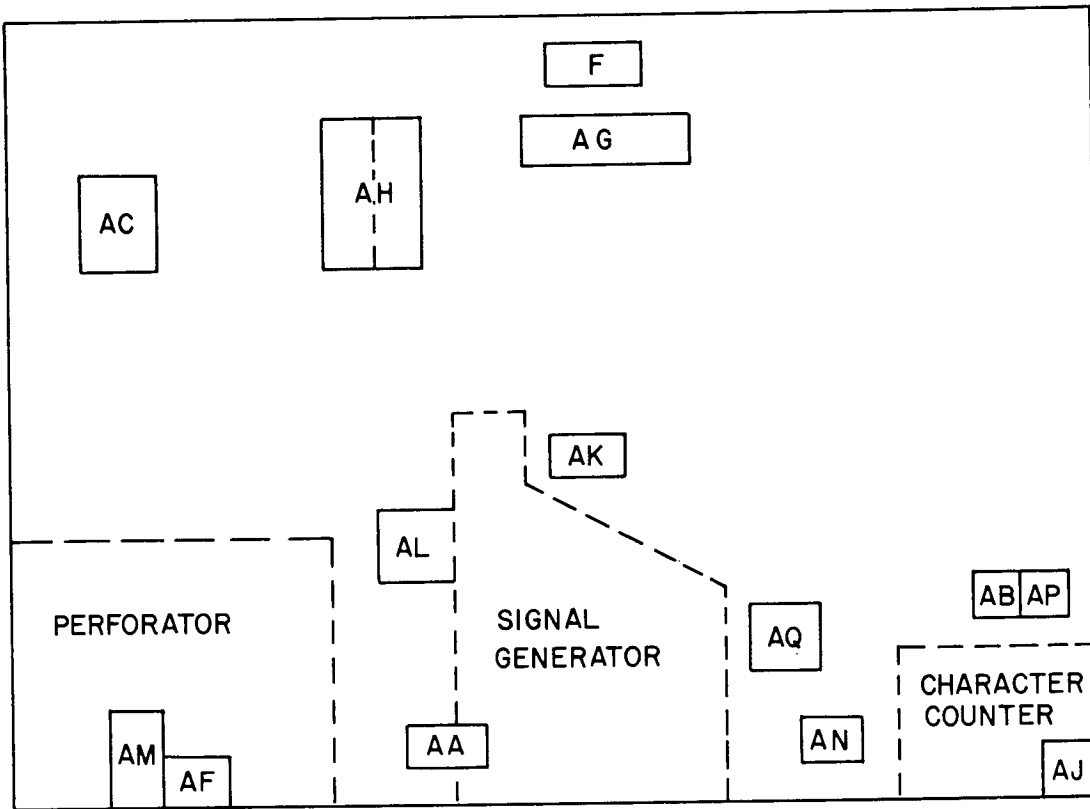

LOCATION OF ELECTRICAL COMPONENTS - KEYBOARD

- | | | | |
|---|--------------------------------|---|--------------------------------------|
| A | SELECTOR MAGNET TERMINAL BLOCK | L | RECTIFIER ASSEMBLY |
| B | LINE-TEST KEY TERMINAL BLOCK | P | CONVENIENCE OUTLET AND FUSE HOLDER |
| D | MOTOR CONTROL TERMINAL BLOCK | Q | POWER SWITCH |
| E | POWER TERMINAL BLOCK | R | TYPING UNIT CABLE AND CONNECTOR |
| F | KEYBOARD CABLE AND CONNECTOR | S | SLOW RELEASE RELAY TERMINAL BLOCK |
| H | LINE SHUNT RELAY | T | SLOW RELEASE TEST KEY TERMINAL BLOCK |
| J | SELECTOR MAGNET DRIVER | U | TD BASE CABLE AND CONNECTOR |
| K | LINE TEST KEY ASSEMBLY | | |

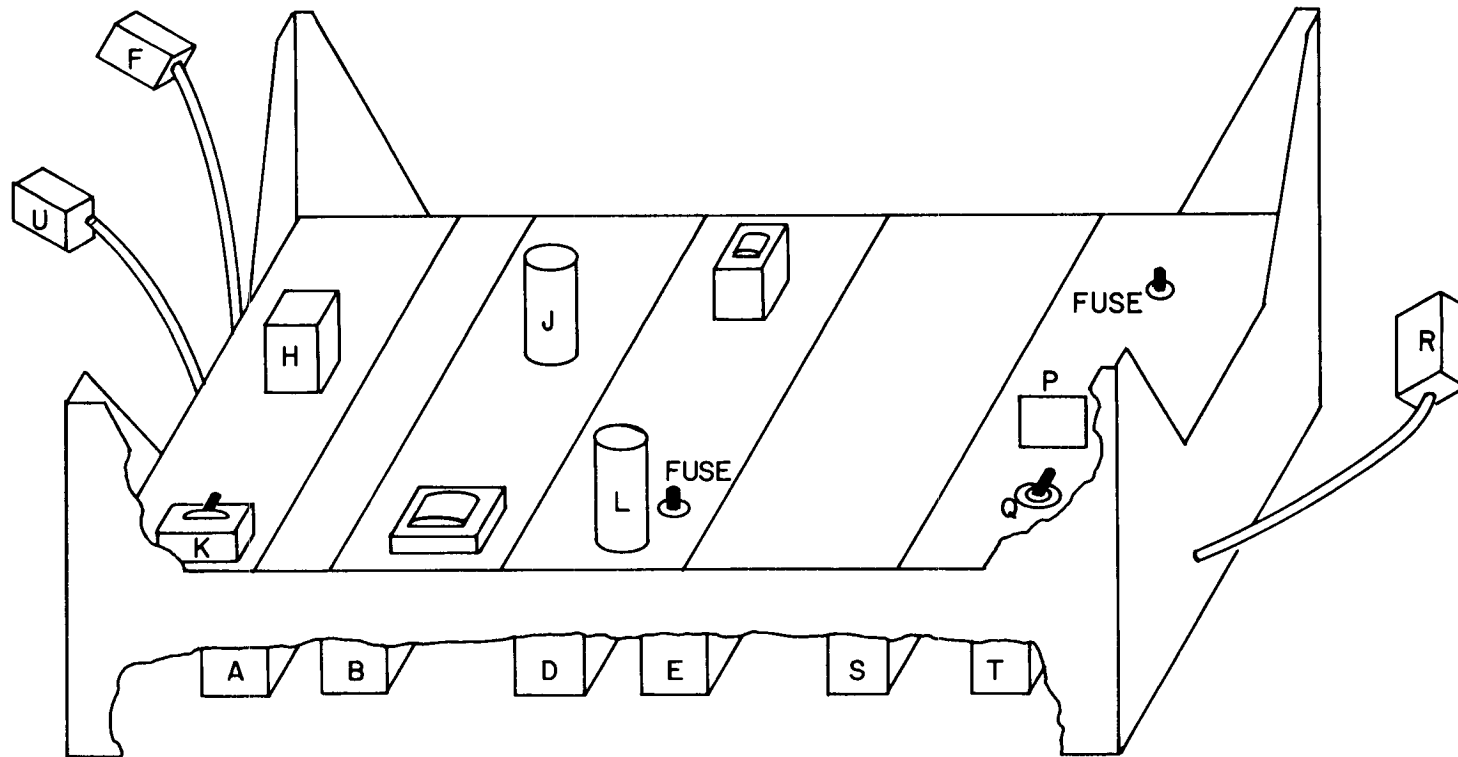

LOCATION OF ELECTRICAL COMPONENTS - UPPER ESU

- VA SIGNAL BELL CONTACTS
- VB SELECTOR MAGNETS
- VH TAPE FEED OUT MAGNETS
- VAA 36 POINT CONNECTOR

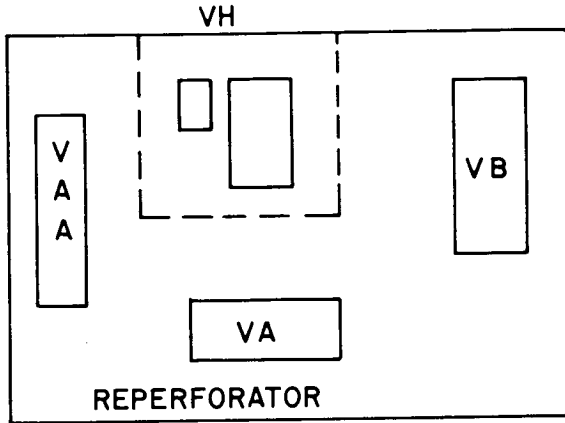

- VA SELECTOR MAGNET TERMINAL BLOCK
- VB NOT USED IN THIS EQUIPMENT
- VD MOTOR CONTROL TERMINAL BLOCK
- VE POWER TERMINAL BLOCK
- VG SIGNAL BELL
- VH LINE SHUNT RELAY
- VJ SELECTOR MAGNET DRIVER

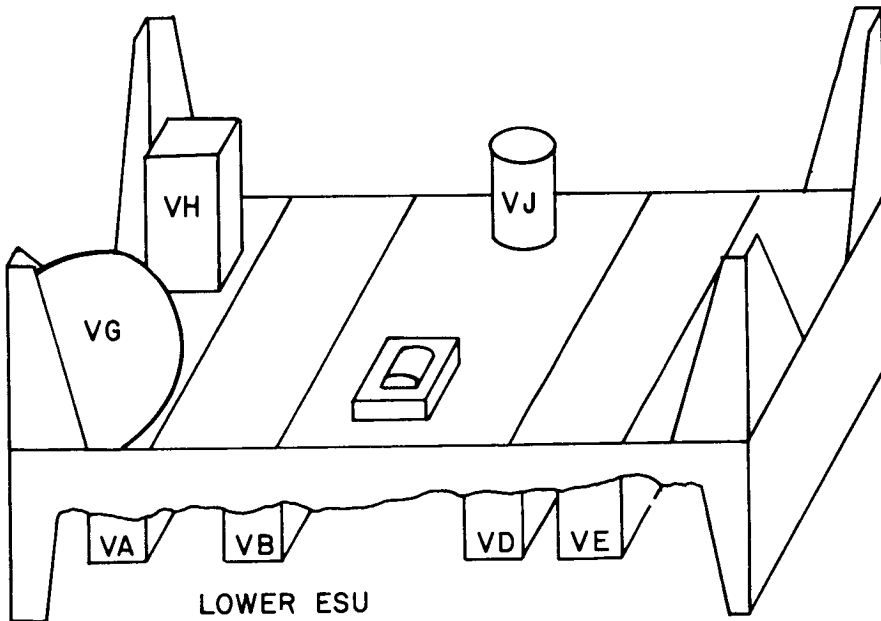

LOCATION OF ELECTRICAL COMPONENTS - REPERFORATOR & LOWER ESU

