

★
NAVELEX 0967-391-6010

TECHNICAL MANUAL

for

LOW-LEVEL TECHNICAL
CONTROL EQUIPMENT
(GENERAL SERVICE)

DEPARTMENT OF THE NAVY
NAVAL ELECTRONIC
SYSTEMS COMMAND

★
PUBLICATION: 10 MARCH 1971

LIST OF EFFECTIVE PAGES

Page Numbers	Change in Effect	Page Numbers	Change in Effect
Title Page	ORIGINAL	2-1 through 2-10	ORIGINAL
ii, iii	ORIGINAL	3-1 through 3-15	ORIGINAL
iv Blank	ORIGINAL	4-1 through 4-15	ORIGINAL
v through xii	ORIGINAL	5-1 through 5-35	ORIGINAL
1-0 through 1-15	ORIGINAL	6-1 through 6-10	ORIGINAL

Naval Electronic Systems Command, Washington Division

Manufacturer's Code - 30272

Contract Number - P.O. 9-3025

Errors found in this publication (other than obvious typographical errors) which have not been corrected by means of Temporary Changes or Permanent Changes should be reported on a user activity comment sheet NAVSHIPS 4914 (10-62) FSN 0105-503-9850. Such reports should include the complete title of the publication and the publication number, identify the page and line or figure and location of the error, and be forwarded to the Publications and Information Retrieval Branch of the Naval Electronic Systems Command.

All requests for this publication should be directed to the Naval Supply Depot, 5801 Tabor Avenue, Philadelphia, Pa., 11920.

FOREWORD

The present, generally accepted system for digital (d. c.) keying in the Naval Communications System is 60-milliampere, 130-volt series (high-level) keying. This high-level keying system is soon to be replaced in communication centers by low-level, polar, d. c. (parallel) keying (shaped $+6 \pm 1$ and -6 ± 1 V at a nominal 1 ma.) in both the secure and nonsecure (Red/Black) areas. Compliance with the low-level operating method is required by various Engineering, Federal, and Military Standards to ensure reduction of compromising emanations at the signal source to an acceptable level, and simultaneously deriving benefits by the selective application of former installation techniques. Conversion to the low-level keying system in existing communication centers will be accomplished when a major reconfiguration is required to upgrade or expand facilities, as necessitated by station mission.

New communication centers are planned to be installed Low-Level throughout. Conversion for the Red and Black side is dependent upon availability of appropriate Red modification kits and Black backfit units for digital modems (VFCT's).

The General Service Technical Control Equipment described herein was designed, developed and is currently being provided by the Naval Electronic Systems Command, Washington Division for use on naval shore installations. The equipment is designed for incorporation within the various functional divisions of communication areas such as Technical Control Facility (TCF), Patch and Test Facility (cryptographic equipment area), and Patch and Test Facility (terminal equipment).

TABLE OF CONTENTS

Paragraph		Page
SECTION I - GENERAL INFORMATION		
1-1	Purpose of Equipment	1-1
1-3	Description	1-1
1-5	Communication Patching Panel (SB-3189A/FGC)	1-1
1-6	Power Supply Assembly (PP-6521/FG)	1-2
1-7	Fuse Panel (SB-3503/FG)	1-5
1-8	Telegraph Repeater (TH-83A/FGC)	1-5
1-9	Terminal Board Assembly (J-2943/FG)	1-8
1-10	Voltmeter (ME-400/FG)	1-8
1-11	Terminal Box (J-2885/UG)	1-8
1-12	Cabinet (CY-597A/U)	1-8
1-13	Quick Reference Data	1-13
SECTION II - INSTALLATION		
2-1	General	2-1
2-3	Unpacking	2-1
	a. General	2-1
	b. Unpacking	2-1
	c. Inspection	2-1
2-4	Power Requirement	2-2
	a. 5 Amp Polar Supply PP-6521/FG	2-2
	b. Hubbing Repeater TH-83A/FGC	2-2

TABLE OF CONTENTS (Contd)

Paragraph		Page
2-5	Installation	2-2
	a. Location	2-2
	b. Mounting	2-2
	c. Cable Connections	2-2
	(1) Patch Panel SB-3189A/FGC	2-2
	(2) 5 Amp Polar Supply PP-6521/FG	2-7
	(3) Alarm and Control Panel P/O PP-6521/FG	2-7
	(4) Fuse Panel SB-3503/FG	2-7
	(5) Hubbing Repeater TH-83A/FGC	2-7
	(6) 3200 Pair Frame J-2885/UG	2-7
2-6	Inspection and Adjustments	2-9
2-8	Preparation for Reshipment	2-10
SECTION III - OPERATION		
3-1	Operating Controls and Indicators	3-1
3-3	Operating Procedures	3-10
3-4	General	3-10
3-5	5 Amp Polar Supply	3-10
3-6	Alarm and Control Panel	3-11
3-7	6 Volt Power Supply	3-12
3-8	Operator's Maintenance	3-13
3-9	General	3-13

TABLE OF CONTENTS (Contd)

Paragraph		Page
3-10	Inspection and Cleaning	3-13
3-11	Adjustments	3-13
	a. 5 Amp Polar Supply (PP-6521/FG)	3-14
	b. 6 Volt Power Supply (P/O TH-83A/FGC)	3-14
3-12	Troubleshooting	3-15
3-13	Minor Parts Replacement	3-15
SECTION IV - MAINTENANCE AND REPAIR		
4-1	General	4-1
4-3	Circuit Analysis	4-1
4-4	Patch Panel (SB-3189A/FGC)	4-1
4-5	5 Amp Polar Supply (PP-6521/FG)	4-1
4-6	Alarm and Control Panel (P/O PP-6521/FG)	4-3
4-7	Fuse Panel (SB-3503/FG)	4-5
4-8	Hubbing Repeater (TH-83A/FGC)	4-5
4-9	Preventive Maintenance	4-8
4-11	General Scheduling Requirements	4-8
4-12	5 Amp Polar Supply Minimum Performance Test	4-9
4-13	Alarm and Control Panel Minimum Performance Test	4-9
4-14	Hubbing Repeater Minimum Performance Test	4-10
4-15	Repair and Replacement	4-12
4-17	Troubleshooting	4-13

TABLE OF CONTENTS (Contd)

Paragraph		Page
SECTION V - PARTS LIST		
5-1	Introduction	5-1
5-3	Reference Designation	5-1
5-5	Part Number	5-1
5-6	Description	5-1
5-7	Manufacturer's Code	5-1
5-8	Quantity Per Assembly	5-2
SECTION VI - DRAWINGS		
6-1	Introduction	6-1

LIST OF ILLUSTRATIONS

Figure		Page
1-1	Typical Low-Level Technical Control Equipment, Block Diagram .	1-0
1-2	Communication Patching Panel SB-3189A/FGC	1-3
1-3	Power Supply Assembly PP-6521/FG	1-4
1-4	Fuse Panel SB-3503/FG	1-6
1-5	Telegraph Repeater TH-83A/FGC	1-7
1-6	Terminal Board Assembly J-2943/FG	1-9
1-7	Voltmeter ME-400/FG	1-10
1-8	Terminal Box J-2885/UG	1-11
1-9	Cabinet CY-597A/U	1-12
2-1	Strapping Option (GS) SB-3189A/FGC, Low-Level Black	2-3
2-2	Strapping Option (GS) SB-3189A/FGC, Send Low-Level (Red).	2-4
2-3	Strapping Option (GS) SB-3189A/FGC, High-Level D. C. Loop	2-5
2-4	Strapping Option (GS) SB-3189A/FGC, Receive Low-Level (Red)	2-6
2-5	Power Supply Assembly PP-6521/FGC, Interconnection Diagram	2-8
3-1	Patch Panel SB-3189A/FGC, Location of Controls	3-2
3-2	Power Supply Assembly PP-6521/FG, Location of Controls	3-5
3-3	Fuse Panel SB-3503/FG, Location of Controls	3-7
3-4	Hubbing Repeater TH-83A/FGC, Location of Controls	3-8
3-5	Meter Panel ME-400/FG, Location of Controls	3-9
5-1	Patch Panel SB-3189A/FGC, Location of Components	5-4
5-2	Polar Power Module P/O PP-6521/FG, Location of Components	5-8

LIST OF ILLUSTRATIONS (Contd)

Figure		Page
5-3	Polar Supply Enclosure P/O PP-6521/FG, Location of Components . . .	5-9
5-4	Printed Circuit Board SRC-A1 P/O PP-6521/FG, Location of Components	5-10
5-5	Alarm and Control Panel Assembly P/O PP-6521/FG, Location of Components	5-13
5-6	Relay Control Board RCB-1 P/O PP-6521/FG, Location of Components	5-14
5-7	Fuse Panel SB-3503/FG, Location of Components	5-16
5-8	Repeater Panel Enclosure P/O TH-83A/FGC, Location of Components .	5-21
5-9	Printed Circuit Board P/O TH-83A/FGC, Location of Components . . .	5-22
5-10	6 Volt Power Supply P/O TH-83A/FGC, Location of Components	5-23
5-11	Printed Circuit Board TCB-1 P/O TH-83A/FGC, Location of Components	5-24
5-12	532 Pair IDF J-2943/FG, Location of Components	5-26
5-13	Meter Panel ME-400/FG, Location of Components	5-28
5-14	3200 Pair Frame J-2885/UG, Location of Components	5-30
6-1	Communication Patching Panel SB-3189A/FGC, Schematic Diagram . . .	6-2
6-2	Communication Patching Panel SB-3189A/FGC, Wiring Diagram	6-3
6-3	Power Supply PP-6521/FG, Schematic Diagram	6-4
6-4	Control and Alarm Panel P/O PP-6521/FG, Schematic Diagram	6-5
6-5	Fuse Panel SB-3503/FG, Wiring Diagram (Typical)	6-6
6-6	Hubbing Repeater Card P/O TH-83A/FGC, Schematic Diagram	6-7

LIST OF ILLUSTRATIONS (Contd)

Figure		Page
6-7	Telegraph Repeater TH-83A/FGC, Wiring Diagram	6-8
6-8	Power Supply P/O TH-83A/FGC, Schematic Diagram	6-9
6-9	Power Supply P/O TH-83A/FGC, Wiring Diagram	6-10
6-10	Typical Low-Level Technical Control Equipment, Line Drawing	6-11

LIST OF TABLES

Table		Page
1-1	Pertinent Nomenclature	1-2
1-2	Quick Reference Data	1-14
2-1	Dimensions and Weights of Panels	2-9
3-1	Controls and Indicators	3-1
4-1	Troubleshooting	4-13
5-1	Major Assemblies	5-2
5-2	Patch Panel SB-3189A/FGC, Parts List	5-3
5-3	5 Amp Polar Supply PP-6521/FG, Parts List	5-5
5-4	Alarm and Control Panel P/O PP-6521/FG, Parts List	5-11
5-5	Fuse Panel SB-3503/FG, Parts List	5-15
5-6	Hubbing Repeater TH-83A/FGC, Parts List	5-17
5-7	532 Pair IDF J-2943/FG, Parts List	5-25
5-8	Meter Panel ME-400/FG, Parts List	5-27
5-9	3200 Pair Frame J-2885/UG, Parts List	5-29
5-10	Cabinet CY-597A/UG, Parts List	5-31
5-11	Manufacturer's Code List	5-33

COMMUNICATIONS CENTER

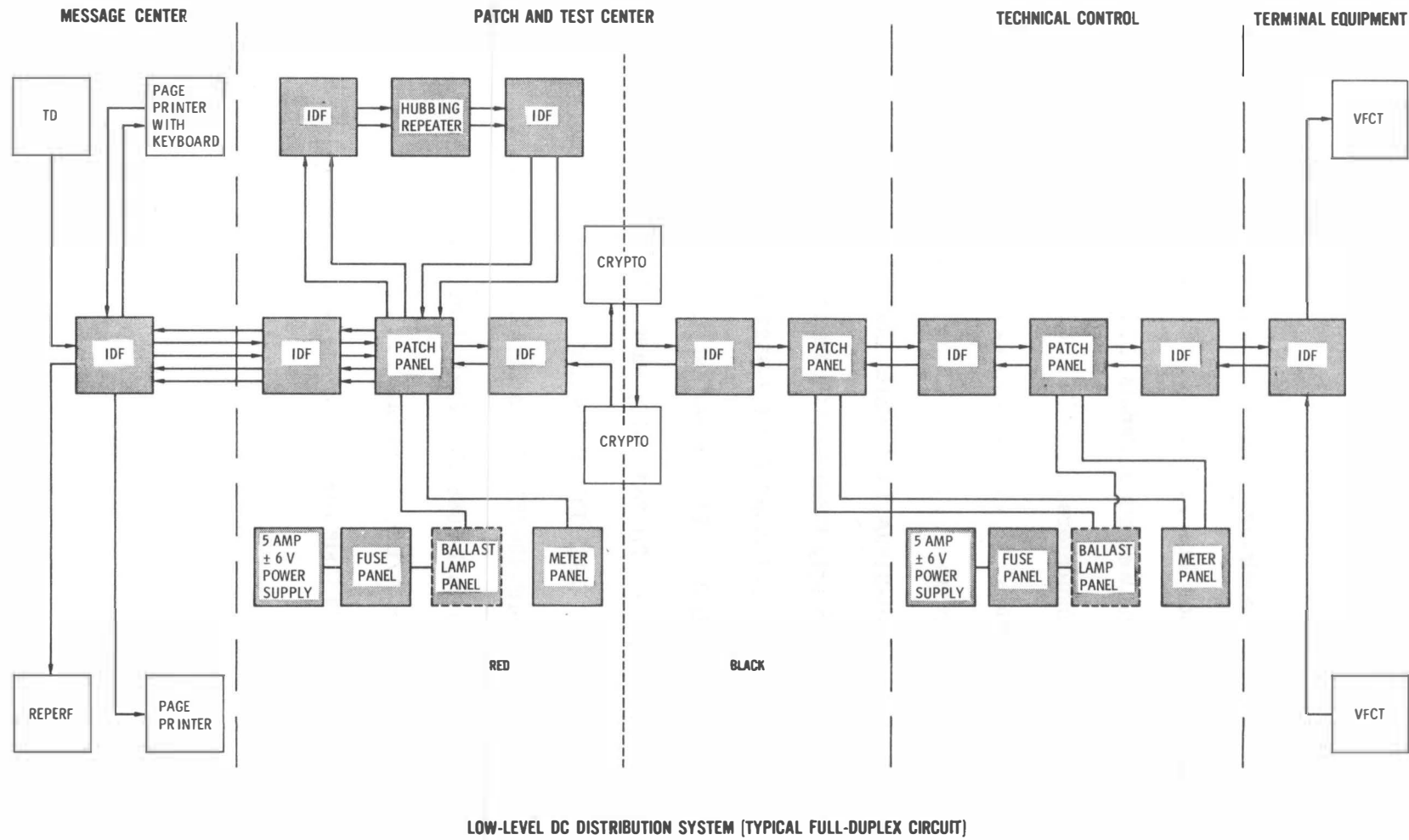

Figure 1-1. Typical Low-Level Technical Control Equipment, Block Diagram

SECTION I

GENERAL INFORMATION

1-1. PURPOSE OF EQUIPMENT.

1-2. The Low-Level Technical Control Equipment was designed and developed by the Naval Electronic Systems Command, Washington Division for General Service use on Naval shore installations. This equipment consists of various components to be used within the functional divisions of communication areas such as Technical Control Facility (TCF), Patch and Test Facility (cryptographic equipment area), and Patch and Test Facility (terminal equipment). Interim high-level (black) patching is provided as an option in the SB-3189A/FGC patch panel. A typical low level technical control equipment configuration is shown in figure 1-1. A schematic presentation of figure 1-1 is given in figure 6-10.

1-3. DESCRIPTION.

1-4. Figure 1-1, shows a typical low-level send and receive full duplex patching system. Each shaded area represents components, which are described in later paragraphs, to provide patching, power, protection, and control of the communications circuits. Table 1-1 lists the official nomenclature and common name of each component in the system.

1-5. COMMUNICATION PATCHING PANEL (SB-3189A/FGC). (See figure 1-2). The Patch Panel is a dual-purpose high-level, low-level patching panel provided for circuit monitoring, routing, and equipment substitution. Jacks are arranged on the front panel in four horizontal rows consisting of 26 jacks in each row. The jacks are terminated on two WECO-type terminal blocks. The rows are designated MON, LINE, EQUIP 1, and EQUIP 2 when

TABLE 1-1. PERTINENT NOMENCLATURE

Item No.	Official Nomenclature	Common Name
1	Panel, Patching, Communication SB-3189A/FGC	Patch Panel
2	Power Supply Assembly PP-6521/FG	a. 5 Amp Polar Supply b. Alarm and Control Panel
3	Panel, Fuse SB-3503/FG	Fuse Panel
4	Repeater, Telegraph TH-83A/FGC	Hubbing Repeater
5	Terminal Board Assembly J-2943/FG	532 Pair IDF
6	Voltmeter ME-400/FG	Meter Panel
7	Terminal Box J-2885/UG	3200 Pair Frame
8	Cabinet CY-597A/U	Cabinet

used in a low-level configuration or LPG 1, LPG 2, SET 1, and SET 2 when used in a high-level mode. Two sets of designation plates with jack row markings are provided with each patch panel chassis. The designation plates are reversible and are marked as previously indicated for low-level on one side and high-level on the opposite side. The Patch Panel is 19-inches wide for standard rack mounting.

1-6. POWER SUPPLY ASSEMBLY (PP-6521/FG). (See figure 1-3.) The Power Supply Assembly consists of two identical ± 6 volt modules, each rated at 5 amperes and an Alarm and Control Panel. Each 5 Amp Polar Power Supply provides regulated ± 6 volts d. c. for low-level signal and control circuits. Both modules are contained within a single

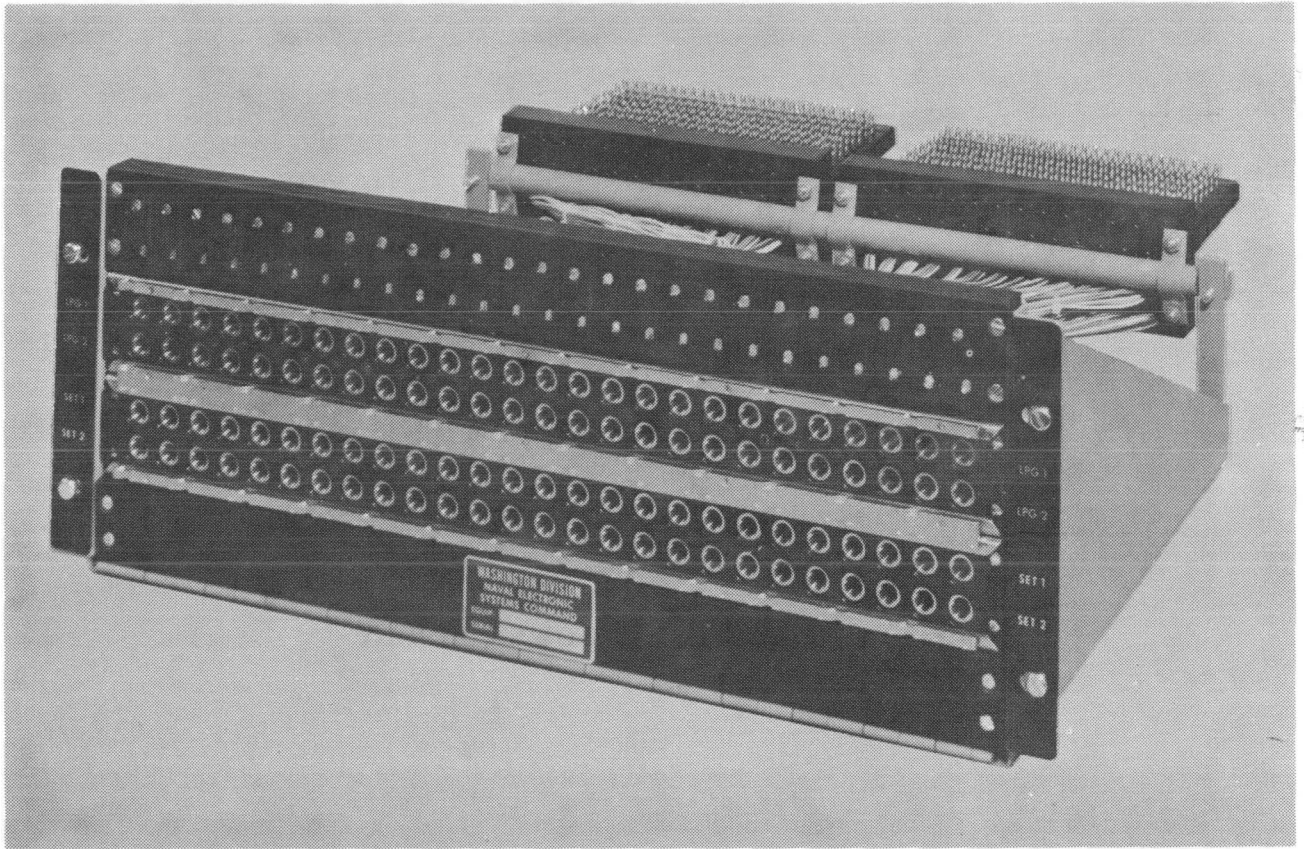
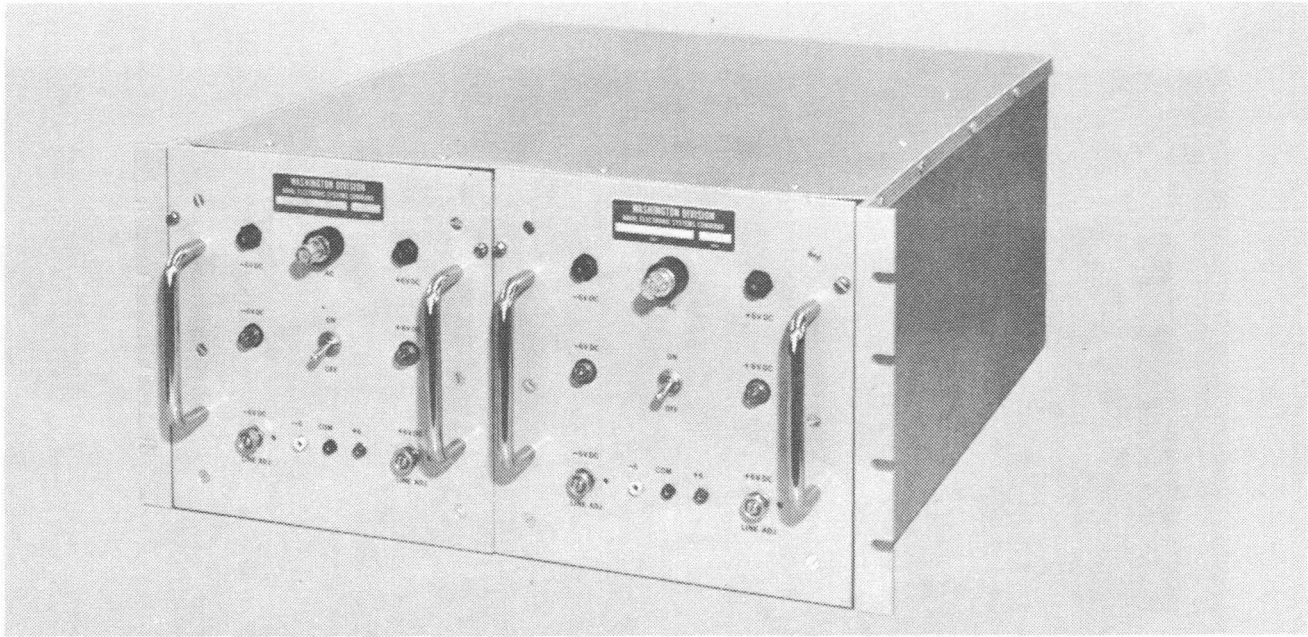
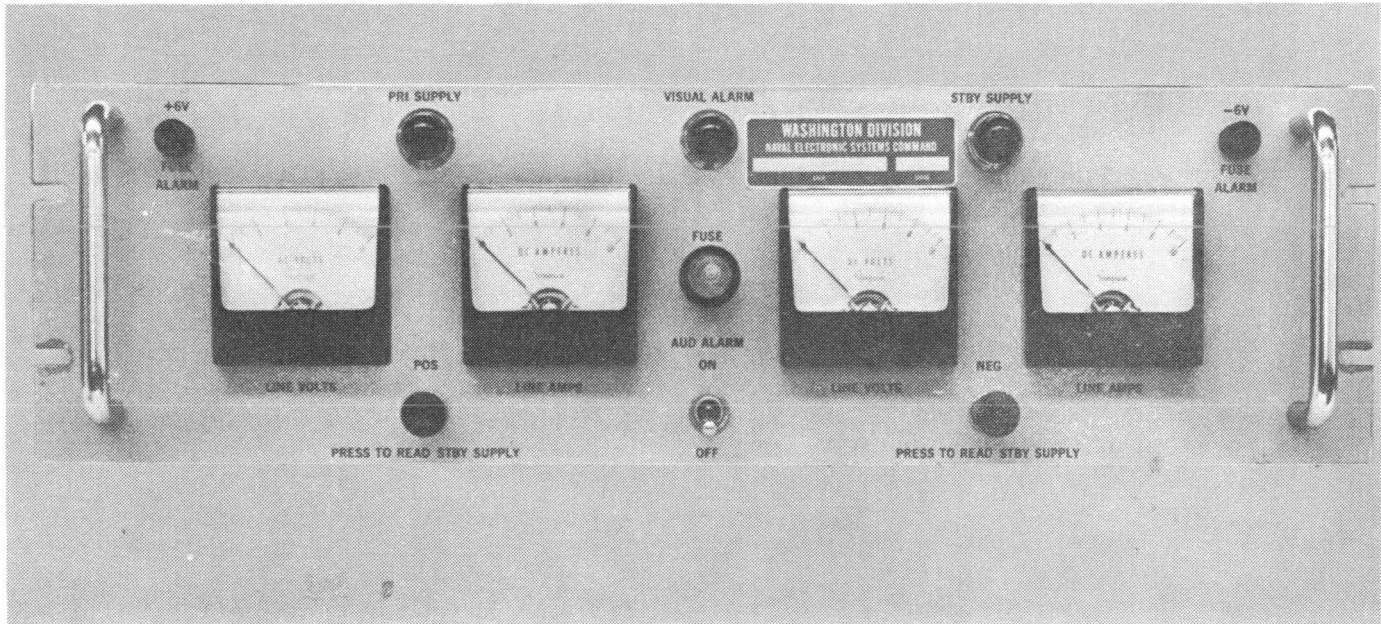

Figure 1-2. Communication Patching Panel SB-3189A/FGC



a. 5 AMP POLAR POWER SUPPLY



b. ALARM AND CONTROL PANEL

Figure 1-3. Power Supply Assembly PP-6521/FG

enclosure assembly and are designed for mounting in a standard 19-inch wide rack. Two terminal blocks are mounted on the rear of the enclosure for a. c. input and d. c. output voltages, and monitor circuits. One power supply module is designated the primary +6 volt d. c. source and the other is available as an alternate in case of power supply failure. The front panel of each module contains the conventional activating control/adjustments and indicators which allow independent operation of each module.

The Alarm and Control Panel provides:

- a. Visual and audible alarm for power supply and/or line failure.
- b. Visual indicators for monitoring of d. c. voltages and line currents.

Each unit of the Power Supply Assembly mounts in a standard 19-inch wide rack.

1-7. FUSE PANEL (SB-3503/FG). (See figure 1-4.) The Fuse Panel contains 52 indicating fuses, each rated at 180 ma, and two ballast lamps which may be used as blown-fuse indicators. This panel will provide up to 26 each +6-volt fused circuits for use on Signal, Step, Mark Hold, Step Inhibit, and Control Relays, as required. The Fuse Panel mounts in a standard 19-inch wide rack.

1-8. TELEGRAPH REPEATER (TH-83A/FGC). (See figure 1-5.) The Hubbing Repeater provides two primary functions:

- a. Combines 2 to 20 +6 volt d. c. inputs on 1 to 20 channels. (The combined inputs must be applied on a time-sharing basis.)
- b. Distributes one or more +6 volt d. c. inputs to up to 20 simultaneous outputs.

Figure 1-4

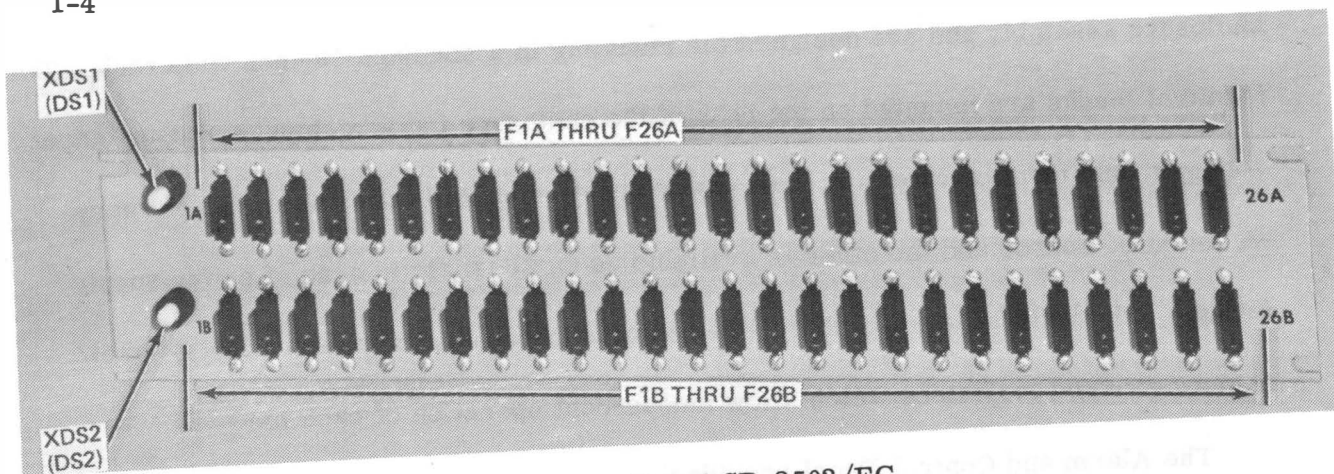

Figure 1-4. Fuse Panel SB-3503/FG

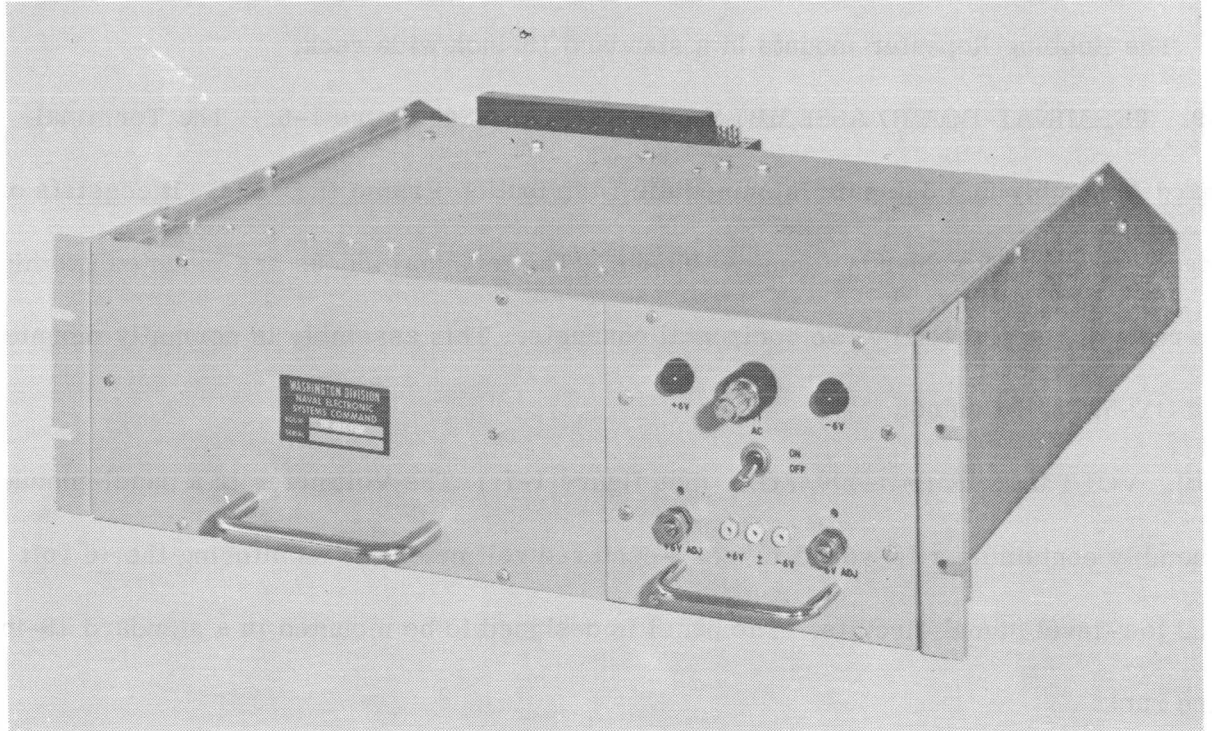

Figure 1-5. Telegraph Repeater TH-83A/FGC

This unit is completely self contained. Signal inputs, outputs, and hubbing points are brought out to a terminal block mounted within the unit. The +6 volt d. c. power supply provides all the d. c. power required for the internal circuits and their respective loads.

The Hubbing Repeater mounts in a standard 19-inch wide rack.

1-9. TERMINAL BOARD ASSEMBLY (J-2943/FG). (See figure 1-6.) The Terminal Board Assembly is a 532 pair Intermediate Distribution Frame (I. D. F.). It consists of 4 each standard 10 x 26-row terminal blocks. The terminal blocks are mounted two high in two rows and supported by two horizontal channels. This assembly is normally mounted in a CY-597A/U Cabinet.

1-10. VOLTMETER (ME-400/FG). (See figure 1-7.) The Voltmeter is a panel-mounted assembly containing a 10-volt d. c. zero-centered voltmeter for monitoring the +6 volt d. c. low-level signal circuits. The panel is designed to be mounted in a standard 19-inch wide rack.

1-11. TERMINAL BOX (J-2885/UG). (See figure 1-8.) The Terminal Box is housed in a ferrous enclosure and designed for floor mounting. It can be used for Main Frame Intermediate Distribution (I. D. F.) or Combined Intermediate Distribution (C. I. D. F.). Sixteen 10 x 26 type terminal blocks are mounted vertically in the front half of the distribution frame and sixteen 10 x 26 terminal blocks are horizontally mounted in the rear portion. The capacity of the Terminal Box is approximately 3200 pairs of connections. The frame is easily expanded by bolting additional sections together.

1-12. CABINET (CY-597A/U). (See figure 1-9.) The Cabinet is provided to accommodate specific combinations of units and 19-inch wide panels. Cable entry facilities are provided

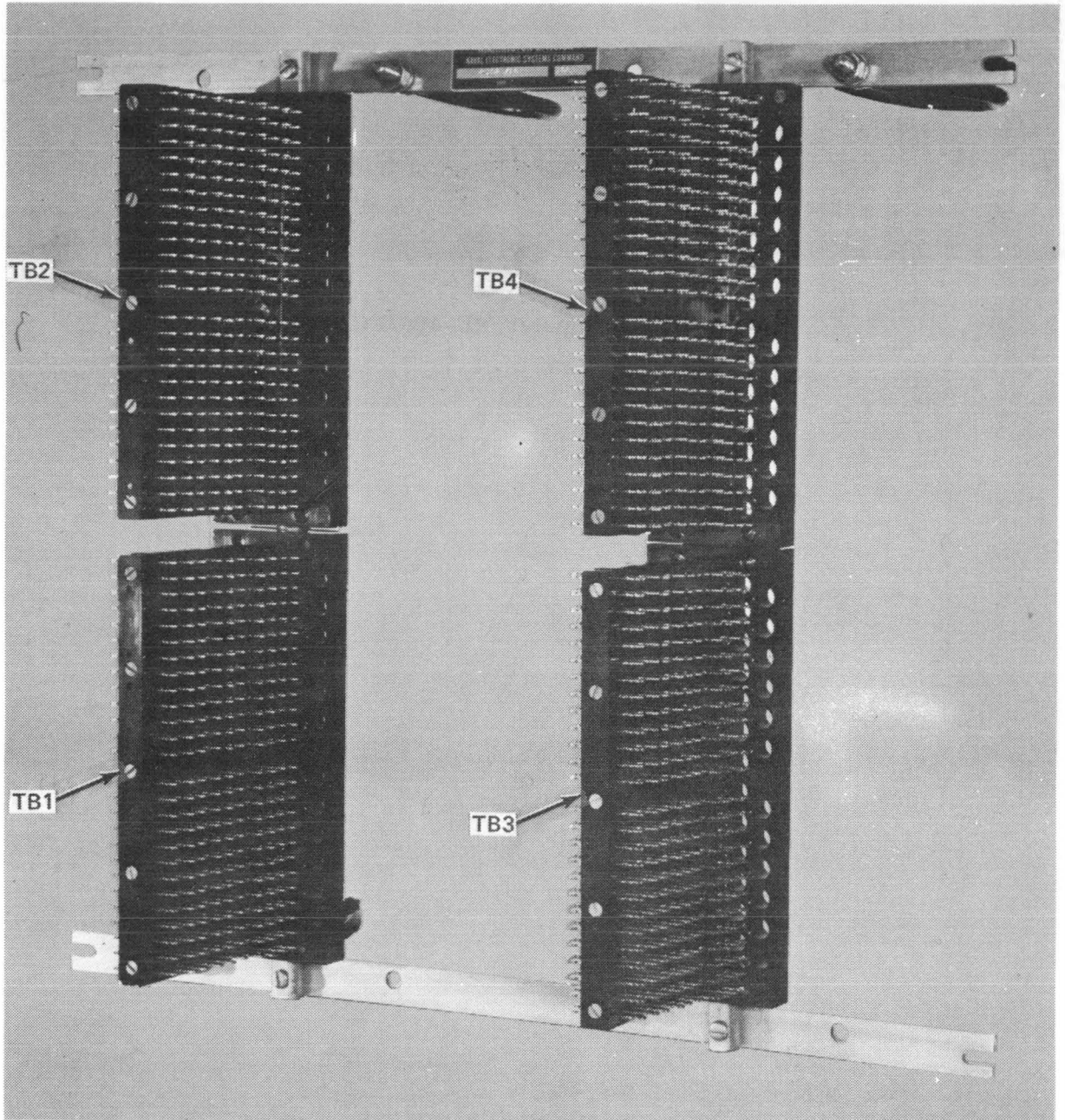

Figure 1-6. Terminal Board Assembly J-2943/FG

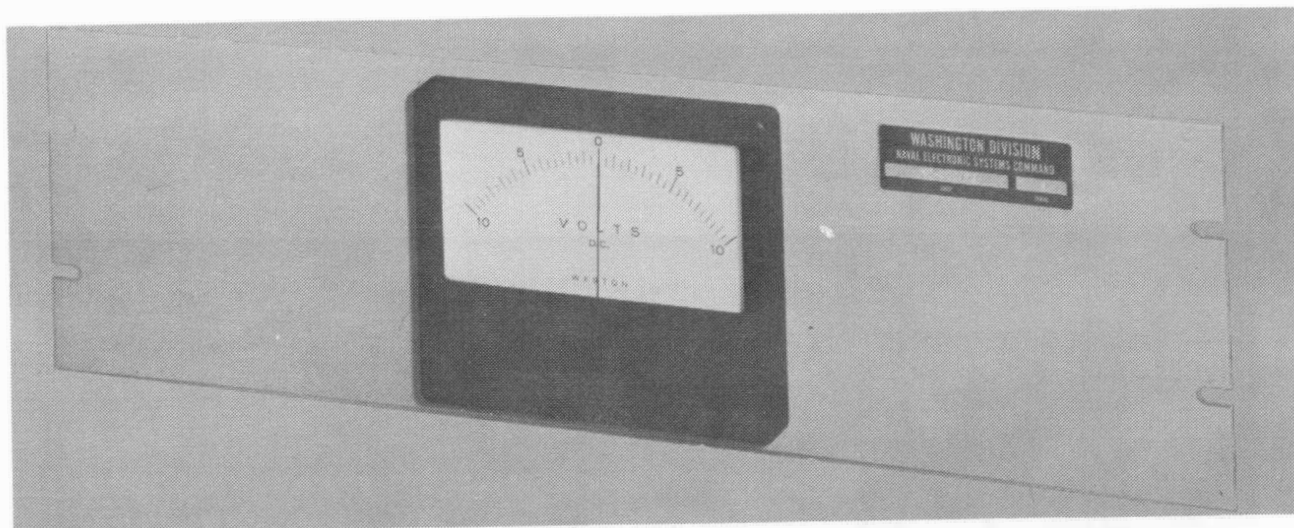

Figure 1-7. Voltmeter ME-400/FG

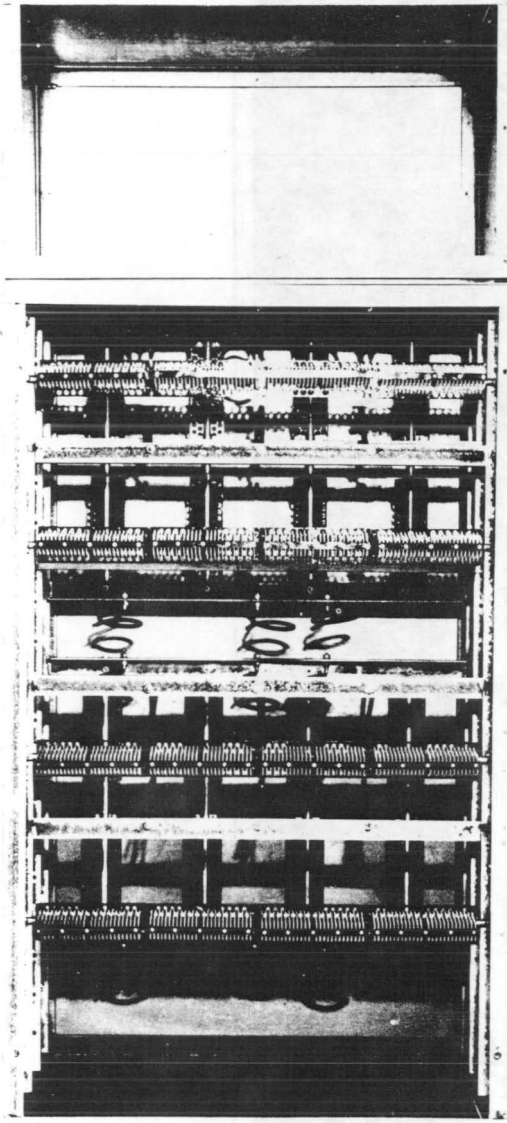

Figure 1-8. Terminal Box J-2885/UG

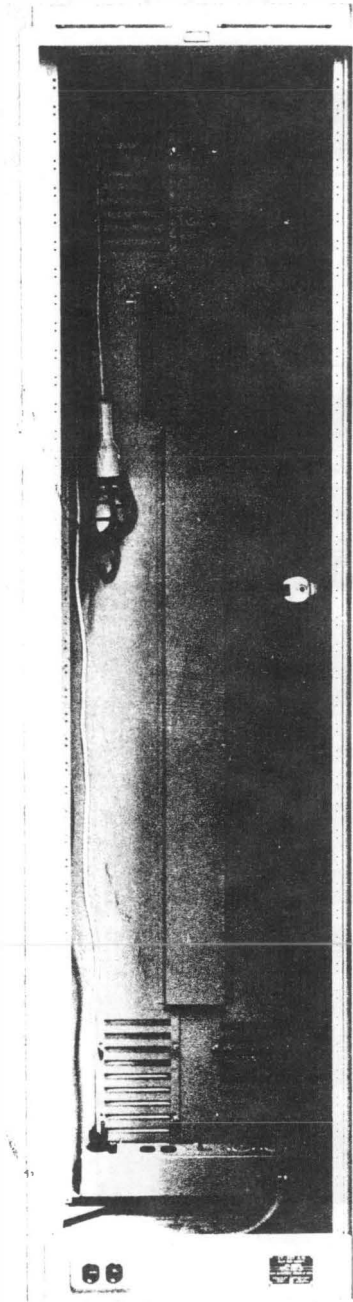

Figure 1-9. Cabinet CY-597A/U

at top and bottom of the cabinet. The Cabinet is designed for floor mounting and is equipped with a hinged rear door.

1-13. QUICK REFERENCE DATA.

1-14. The data tabulated in table 1-2 shows the relationship between units as well as quick reference data.

TABLE 1-2. QUICK REFERENCE DATA

Characteristic	Specification
<u>Patch Panel</u>	
Number of Jacks	104
<u>5 Amp Polar Supply</u>	
Input Voltage	115 volts a. c.
Regulated Output Voltage	±6 volts d. c.
Current Rating	5 amperes
<u>Alarm and Control Panel</u>	
Type of Alarm Indication	Visual and audible
Actuation Voltage	±6 volts d. c.
<u>Fuse Panel</u>	
Number of Ballast Lamps	2
Number of Fuses	52
Type of Ballast Lamps	6 volts 40 milliamperes
Type of Fuses	18/100 ampere (GMT)
<u>Hubbing Repeater</u>	
Number of Printed Circuit Boards	10
Number of Channels	20
Input Voltage	115 volts a. c.
Operating Voltage	±6 volts d. c.

TABLE 1-2. QUICK REFERENCE DATA (Contd)

Characteristic	Specification
<u>532 Pair I. D. F.</u>	
Capacity	532 pairs
Number of Terminal Blocks	4
<u>Meter Panel</u>	
Number of Meters	1
Type of Meter	10 volts d. c. zero-centered
<u>3200 Pair Frame</u>	
Capacity	3200 pairs
Number of Terminal Blocks	32

SECTION II

INSTALLATION

2-1. GENERAL.

2-2. These instructions contain information pertinent to unpacking, location, mounting, and installation of the components described herein. They include initial checks and adjustments required to put the equipment in proper operating condition.

2-3. UNPACKING.

a. GENERAL. - All units including accessories have been carefully packed prior to shipment to insure proper protection during shipment. Extreme care must be exercised while handling and unpacking the units to prevent damage.

b. UNPACKING. - The equipment should be unpacked with caution and should be handled in the same manner as any electrical or electronic instrument. To unpack, proceed as follows:

- (1) Open shipping carton.
- (2) Remove individually packed panels.
- (3) Remove panels from cartons.

When shipping carton has been opened, inspect for signs of damage as a result of shipment. When satisfied that the container is in proper condition, unpack carefully so that no damage occurs to panel faces, meters, or knobs.

c. INSPECTION. - Check the equipment for possible damage as a result of shipment before installation. Carefully inspect component mounting boards, switches, solder connections, etc.

2-4. POWER REQUIREMENT.

a. 5 AMP POLAR SUPPLY PP-6521/FG. - The 5 Amp Polar Supply requires 115 volts a. c. operating voltage. The Alarm and Control Panel, containing a visual and audible alarm, requires 115 volts a. c. operating voltage.

b. HUBBING REPEATER TH-83A/FGC. - The Hubbing Repeater requires +6 volts d. c. input from a self-contained power supply which has a 115 volt a. c. operating voltage.

2-5. INSTALLATION

a. LOCATION. - Components should be located where personnel have ample room to maintain and operate the units. The 3200 Pair Frame and Cabinet are floor-mounted and must be located so that access to the back of the panels can be accomplished. The rear doors require a minimum of 20 inches to open. The Alarm and Control Panel may be installed adjacent to, or in a remote area from the 5 Amp Polar Supply.

b. MOUNTING. - Except for the 3200 Pair Frame and Cabinet all components are mounted in 19-inch racks. See Table 2-1 for the dimensions of each panel.

c. CABLE CONNECTIONS. - Enclosed units have cable entry holes at the top and bottom. Those units which are not enclosed may be wired directly.

(1) PATCH PANEL SB-3189A/FGC. - (See figures 2-1 thru 2-4.) Strapping options may be made as installation conditions dictate. Cable entry is facilitated at the rear of the panel. All connections are made to two (2) 10 x 26-row WECO type terminal blocks as shown in figure 6-2.

NOTE

The terminal block connections on this equipment are numbered RIGHT-TO-LEFT, not the conventional left-to-right.

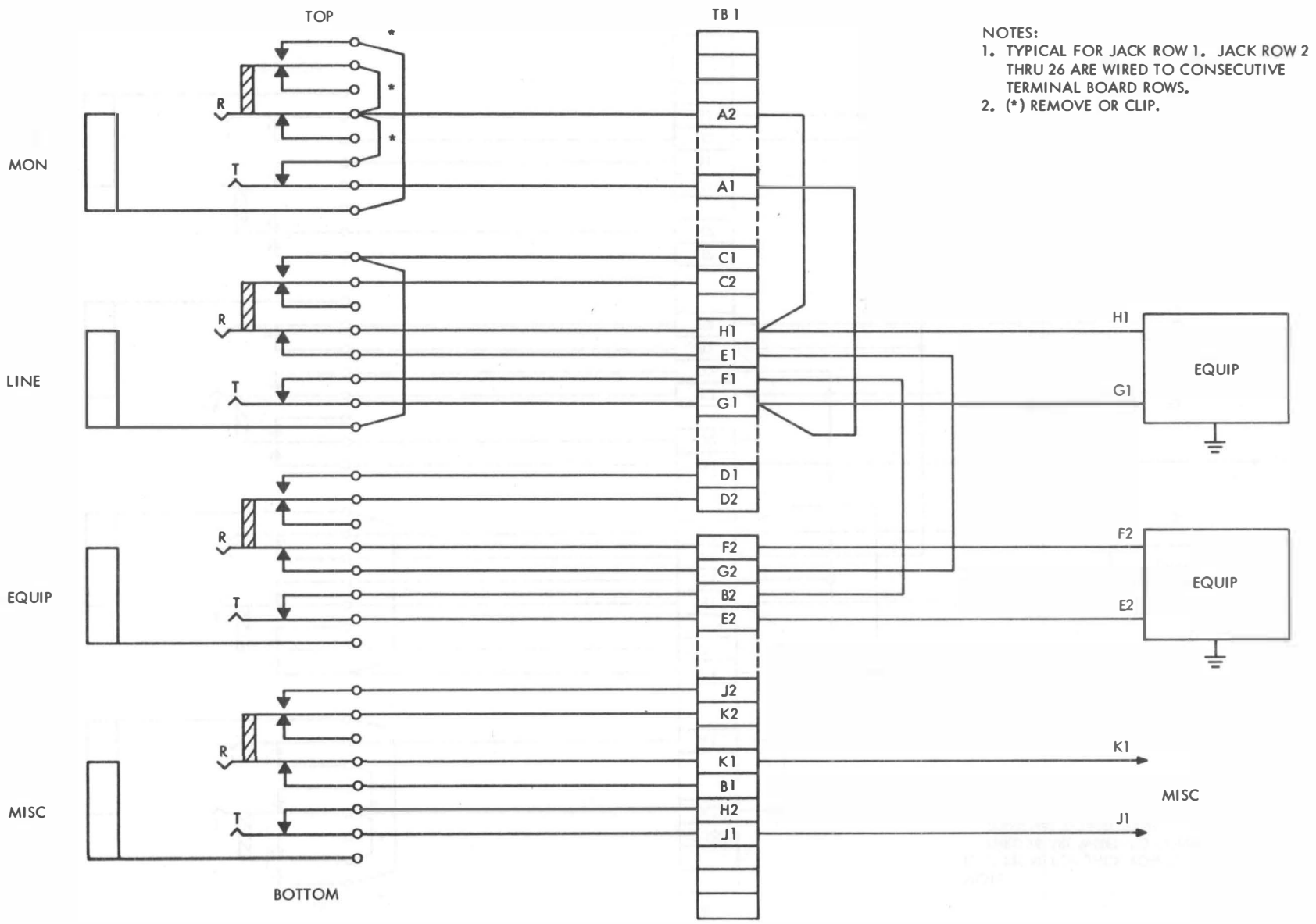
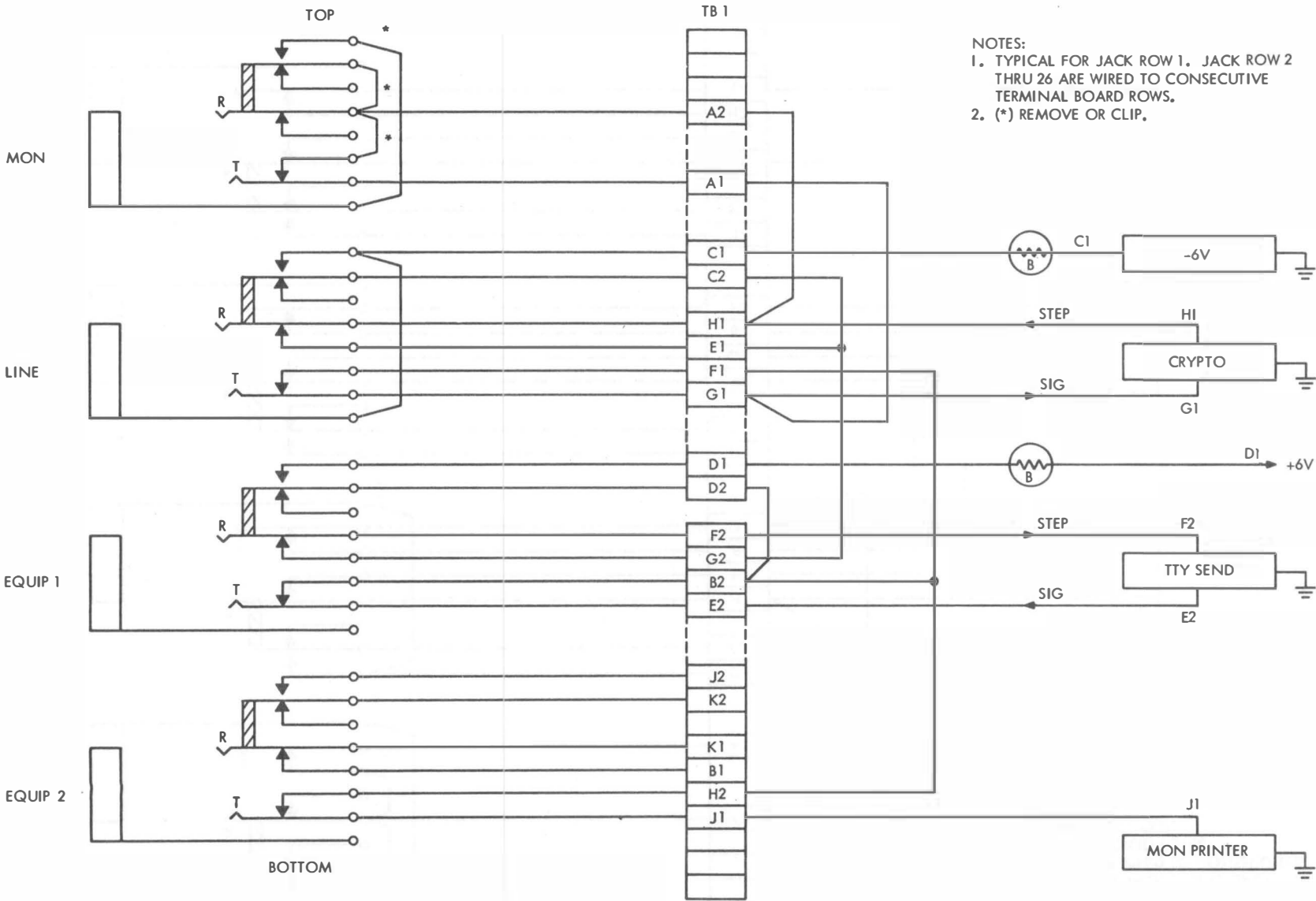

Figure 2-1. Strapping Option (GS) SB-3189A/FGC, Low-Level (Black)



- NOTES:
 1. TYPICAL FOR JACK ROW 1. JACK ROW 2 THRU 26 ARE WIRED TO CONSECUTIVE TERMINAL BOARD ROWS.
 2. (*) REMOVE OR CLIP.

Figure 2-2. Strapping Option (GS) SB-3189A/FGC, Send Low-Level (Red)

N-1509

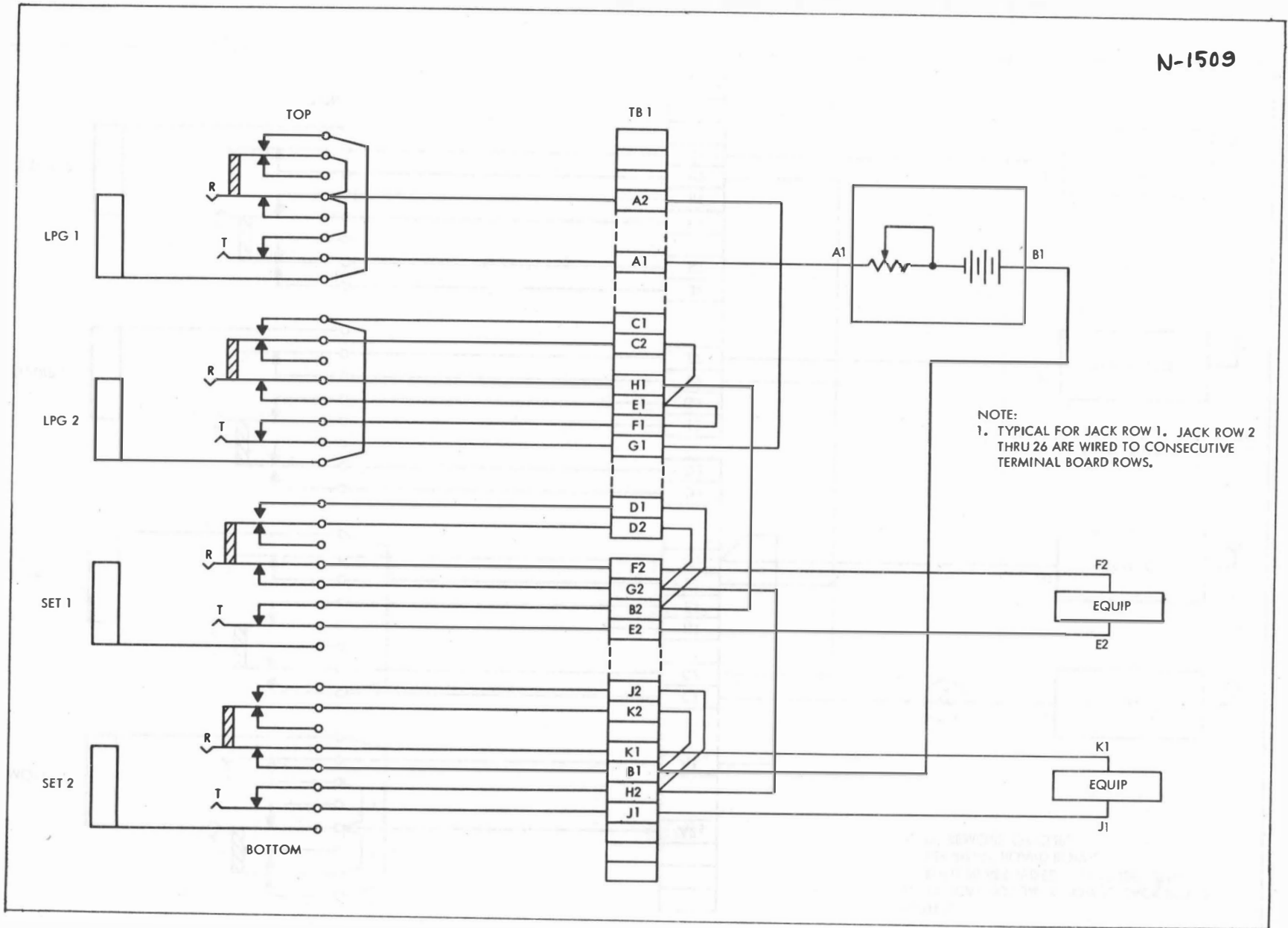

Figure 2-3. Strapping Option (GS) SB-3189A/FGC, High-Level D.C. Loop

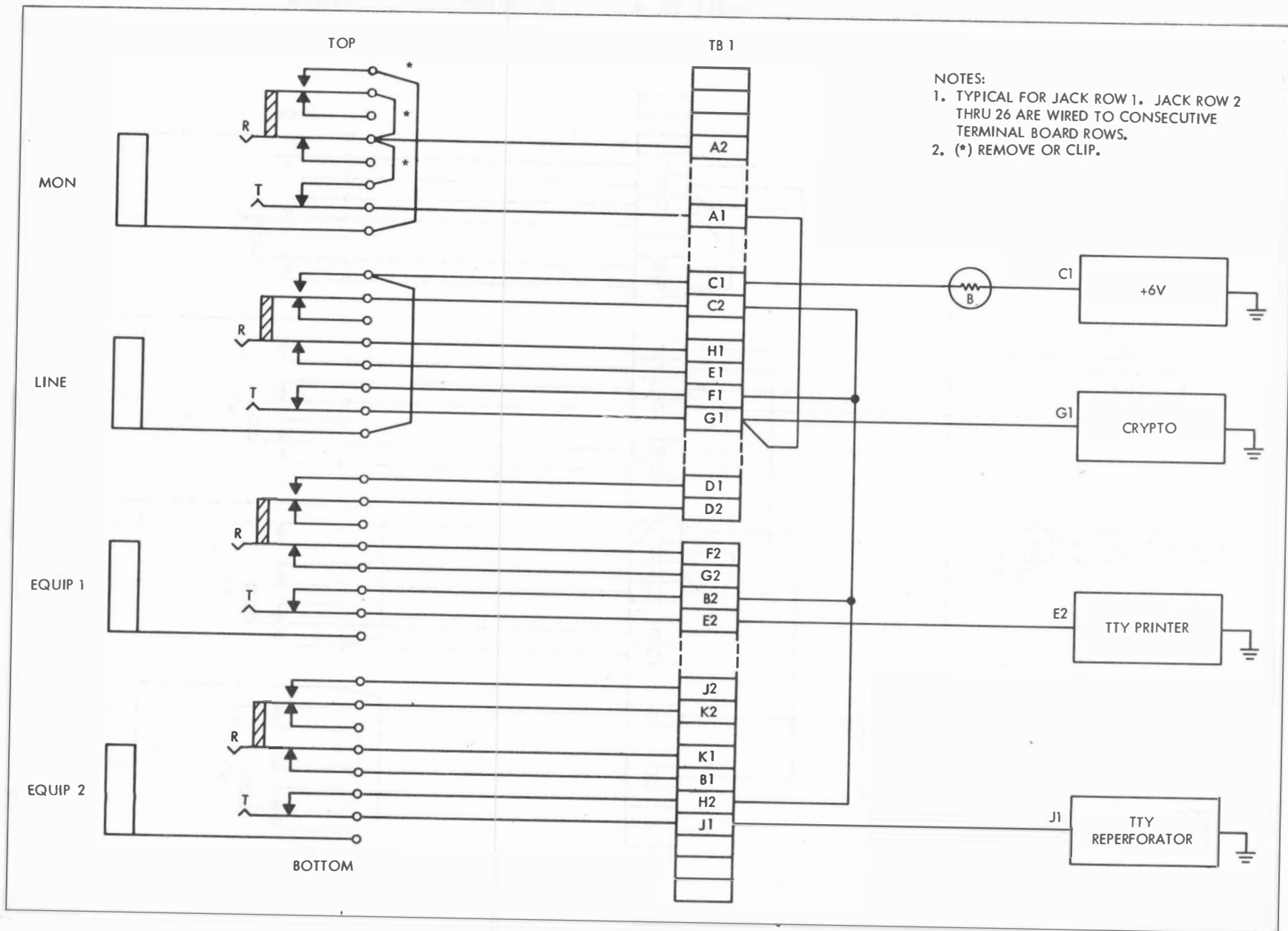

Figure 2-4. Strapping Option (GS) SB-3189A/FGC, Receive Low-Level (Red)

(2) 5 AMP POLAR SUPPLY PP-6521/FG. - (See figure 2-5.) Interconnections may be facilitated as shown.

NOTE

The a. c. power connections are shown as two (2) separate feeds (one to terminal board A1TB1 and one to A1TB2). These may be separate breakers. However, as installation conditions dictate, these may be wired parallel, using one common feed line.

Install both of the 5 Amp Polar Supply modules in the enclosure. Connect the enclosure plugs to their respective modules.

(3) ALARM AND CONTROL PANEL P/O PP-6521/FG. - (See figure 2-5.) Interconnections may be facilitated as shown.

NOTE

The Alarm and Control Panel will usually be located directly above the 5 Amp Polar Supply.

Plug the a. c. cord on the Alarm and Control Panel in a 115 volt cabinet service outlet.

(4) FUSE PANEL SB-3503/FG. - (See figure 6-5.) Interconnections may be facilitated as shown, but must be accomplished to meet local requirements.

(5) HUBBING REPEATER TH-83-A/FGC. - Cable entry is facilitated at the rear of the enclosure. Connections are made to a 10 x 26-row WECO type terminal block.

(6) 3200 PAIR FRAME J-2885/UG. - Cable entry is facilitated by the cable entrance frame at the top or bottom of the terminal box.

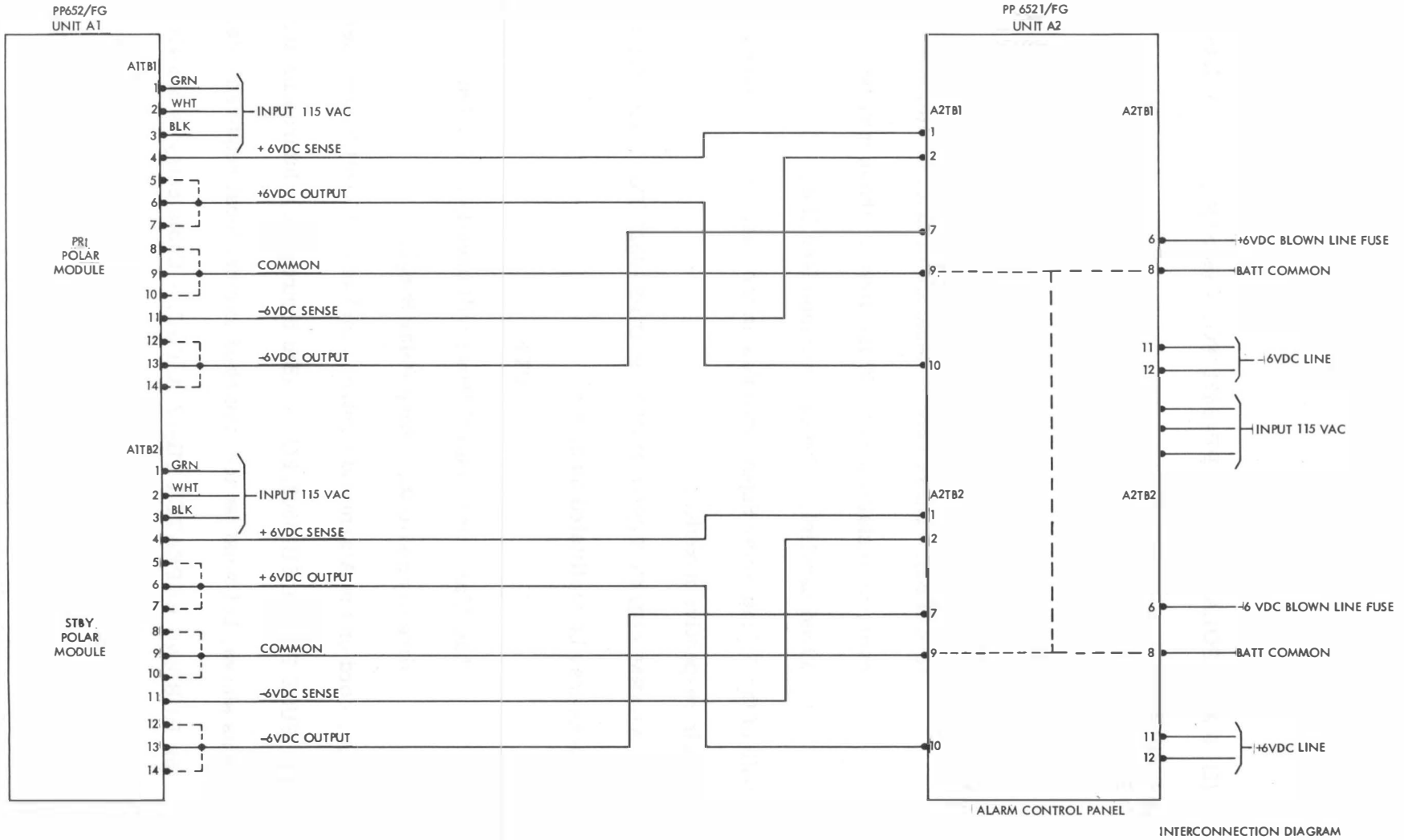

Figure 2-5. Power Supply Assembly PP-6521/FGC, Interconnection Diagram

2-6. INSPECTION AND ADJUSTMENTS.

2-7. All units have been checked prior to shipment and should require only minor initial inspection. A close visual inspection should be made to assure that there is no physical damage due to rough handling during shipment. There are adjustments necessary before placing the equipment in operation. (See Section III.)

TABLE 2-1. DIMENSIONS AND WEIGHTS OF EQUIPMENT

Name and Designation	Height (inches)	Width (inches)	Depth (inches)	Weight (pounds)
Patch Panel SB-3189A/FGC	6 3/4	19	18	33 lbs.
Enclosure with 2 ea. 5 Amp Polar Power Modules.	8 3/4	19	20	40
Alarm and Control Panel P/O PP-6521/FG	5 7/32	19	6 5/6	5
Fuse Panel SB-3503/FG	3 15/32	19	1 7/16	2
Hubbing Repeater TH-83A/FGC	5 7/32	19	17	11
532 Pair IDF J-2943/FG	18 1/2	19	6	8
Meter Panel ME-400/FG	5 1/4	19	N/A	2
3200 Pair Frame J-2885/UG	60	36	28	265

2-8. PREPARATION FOR RESHIPMENT.

a. If the equipment is to be packed for reshipment, the equipment should be water-proofed and crated for overseas shipment except where overseas shipment is not required.

b. The unit should be packed in accordance with the procedure used for shipment of delicate electronic equipment.

c. When required, packages shall be water-vapor-proofed by enclosing the equipment with the right amount of activated desiccant within a water-vapor-proofed barrier. Refer to Navy standard packaging instructions and Military Specification MIL-E-17555.

SECTION III

OPERATION

3-1. OPERATING CONTROLS AND INDICATORS.

3-2. The operating controls and indicators, reference designations, and functions are listed in table 3-1 and are illustrated in figures 3-1 through 3-5. All controls are identified by the front panel markings for ease of identification, and are arranged for ease of operation.

TABLE 3-1. CONTROLS AND INDICATORS

Control or Indicator	Reference Designation	Function
PATCH PANEL SB-3189A/FGC (SEE FIGURE 3-1)		
LPG 1 (jacks)	J1-J26	Enables monitoring of active circuit.
LPG 2 (jacks)	J1-J26	Enables monitoring of active circuit.
SET 1 (jacks)	J1-J26	Enables operator to break normal through-circuit configuration in event of emergency and substitute different equipments/lines as required.
SET 2 (jacks)	J1-J26	Enables operator to break normal through-circuit configuration in event of emergency and substitute different equipments/lines as required.
MON*(jacks)	J1-J26	Enables monitoring of active circuit.
LINE*(jacks)	J1-J26	Enables operator to break normal through-circuit configuration in event of emergency and substitute different equipments/lines as required.
EQUIP 1*(jacks)	J1-J26	Enables operator to break normal through-circuit configuration in event of emergency and substitute different equipments/lines as required.
EQUIP 2*(jacks)	J1-J26	Enables operator to break normal through-circuit configuration in event of emergency and substitute different equipments/lines as required.
MISC*(jacks)	J1-J26	Provides circuit for misc equipment termination as required.

*Reverse side of Designation Plate.

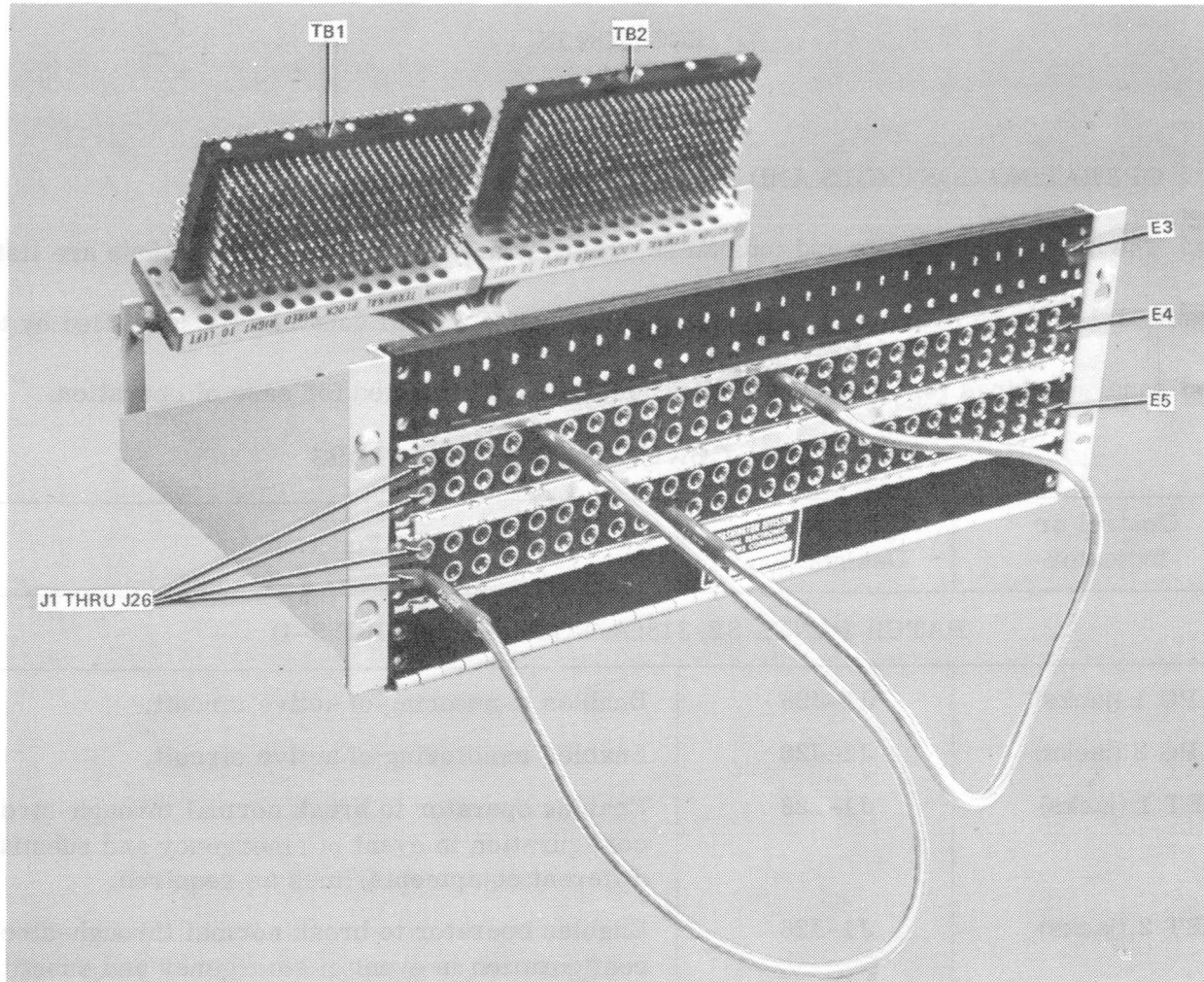

Figure 3-1. Patch Panel SB-3189A/FGC, Location of Controls

TABLE 3-1. CONTROLS AND INDICATORS (Contd)

Control or Indicator	Reference Designation	Function
5 AMP POLAR SUPPLY PP-6521/FG (SEE FIGURE 3-2a)		
ON-OFF (switch)	S1	115 volt a. c. primary power on-off switch.
AC (fuse)	F1	Provides overload protection for input power line.
-6VDC (circuit breaker)	CB1	Provides overload protection for -6 volt d. c. power supply.
+6VDC (circuit breaker)	CB2	Provides overload protection for +6 volt d. c. power supply.
-6VDC (lamp)	DS1	Indicates -6 volt d. c. power on.
+6VDC (lamp)	DS2	Indicates +6 volt d. c. power on.
-6VDC LINE ADJ (potentiometer)	R4	Adjusts -6 volt d. c. line voltage (between -5 volts d. c. and -7 volts d. c.).
+6VDC LINE ADJ (potentiometer)	R13	Adjusts +6 volt d. c. line voltage (between +5 volts d. c. and +7 volts d. c.).
-6 (test jack)	TP1	Provides external meter connection to read -6 volt d. c. line voltage.
COM (test jack)	TP2	Provides common external meter connection to read polar line voltages.
+6 (test jack)	TP3	Provides external meter connection to read +6 volt d. c. line voltage.

TABLE 3-1. CONTROLS AND INDICATORS (Contd)

Control or Indicator	Reference Designation	Function
ALARM AND CONTROL PANEL P/O PP-6521/FG (SEE FIGURE 3-2b)		
PRI SUPPLY (lamp)	DS1	Indicates primary power module is on line.
STBY SUPPLY (lamp)	DS2	Indicates standby power module is on line.
VISUAL ALARM (lamp)	DS3	Indicates failure of one or both power modules or failure on positive or negative buss fuse.
+6V FUSE ALARM (lamp)	DS4	Provides visual indication of blown fuse in +6 volt d. c. buss.
-6V FUSE ALARM (lamp)	DS5	Provides visual indication of blown fuse in -6 volt d. c. buss.
AUD ALARM ON-OFF (switch)	S1	Enables cutoff of audible alarm (VISUAL ALARM remains on).
PRESS TO READ STBY SUPPLY (POS) (switch)	S2	Removes positive line voltmeter from line and indicates +6 volt d. c. from standby supply.
PRESS TO READ STBY SUPPLY (NEG) (switch)	S3	Removes negative line voltmeter from line and indicates -6 volt d. c. from standby supply.



a. 5 AMP POLAR POWER SUPPLY

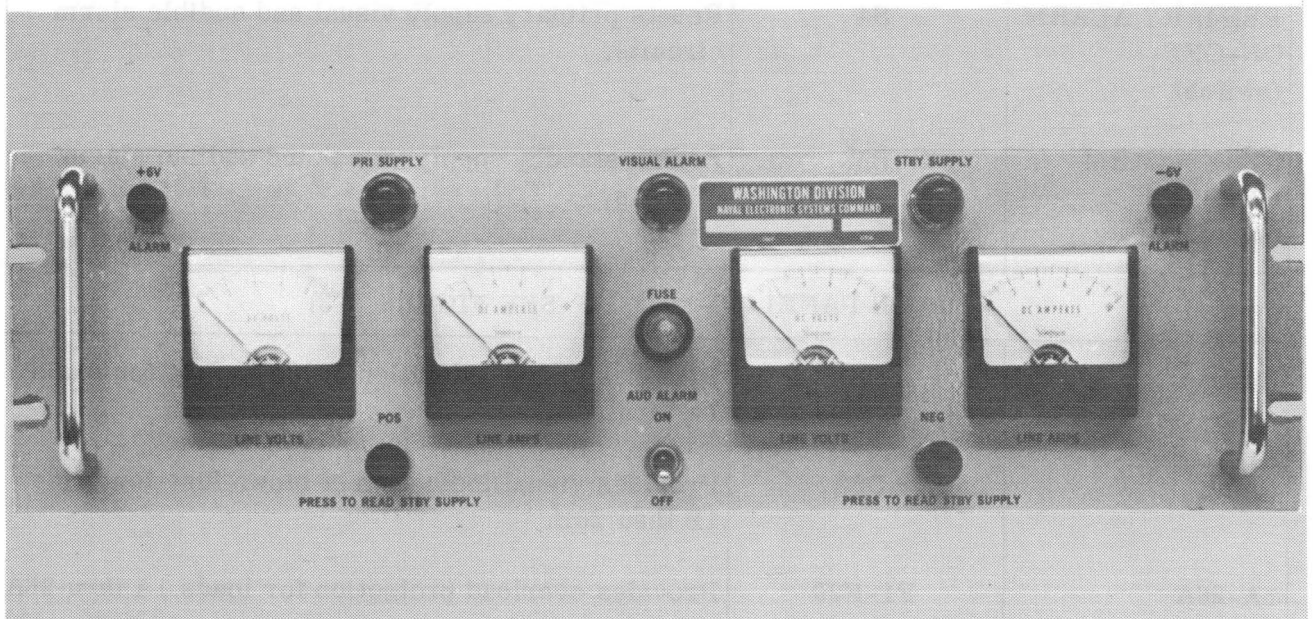

b. ALARM AND CONTROL PANEL

Figure 3-2. Power Supply Assembly PP-6521/FG, Location of Controls

TABLE 3-1. CONTROLS AND INDICATORS (Contd)

Control or Indicator	Reference Designation	Function
ALARM AND CONTROL PANEL P/O PP-6521/FG (SEE FIGURE 3-2b)		
LINE VOLTS (POS) (voltmeter)	M1	Monitors positive line voltage.
LINE AMPS (POS) (ammeter)	M2	Monitors positive line current.
LINE VOLTS (NEG) (voltmeter)	M3	Monitors negative line voltage.
LINE AMPS (NEG) (ammeter)	M4	Monitors negative line current.
(Rear Panel)		
PRIMARY ALARM ON-OFF (switch)	S4	Resets primary supply visual and audible alarm circuits.
STBY ALARM ON-OFF (switch)	S5	Resets standby supply visual and audible alarm circuits.
FUSE PANEL SB-3503/FG (SEE FIGURE 3-3)		
(lamp)	DS1	Provides visual indication of blown fuse for loads 1A thru 26A.
(lamp)	DS2	Provides visual indication of blown fuse for loads 1B thru 26B.
1A-26A (fuse)	F1-F26	Provides overload protection for loads 1A thru 26A.
1B-26B (fuse)	F27-F52	Provides overload protection for loads 1B thru 26B.

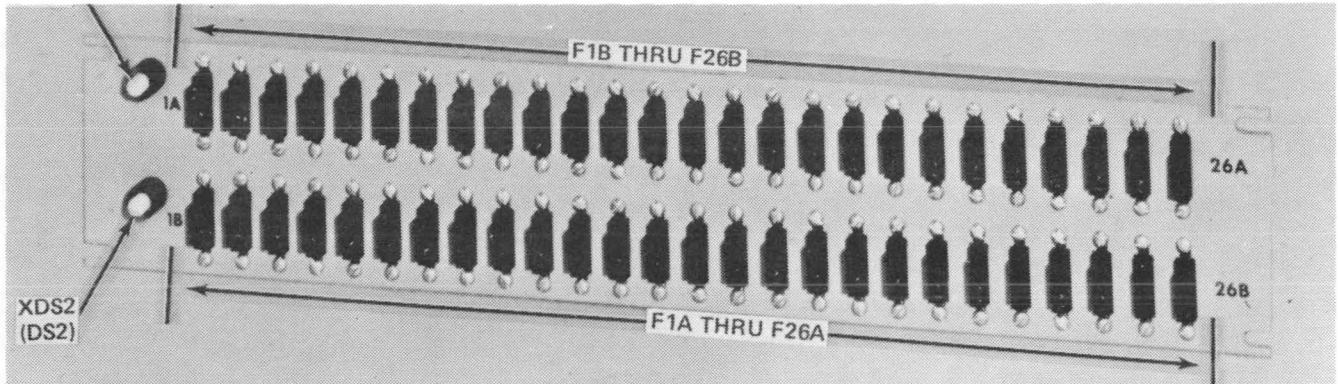

Figure 3-3. Fuse Panel SB-3503/FG, Location of Controls

TABLE 3-1. CONTROLS AND INDICATORS (Contd)

Control or Indicator	Reference Designation	Function
6 VOLT POWER SUPPLY P/O TH-83A/FGC (SEE FIGURE 3-4)		
AC ON-OFF (switch)	S1	115 volt a.c. primary power on-off switch.
F1 (fuse)	F1	Provides overload protection for input power line.
+6V (lamp)	DS1	Indicates +6 volt d.c. power on.
-6V (lamp)	DS2	Indicates -6 volt d.c. power on.
+6V ADJ (potentiometer)	R6	Adjusts +6 volt d.c. line voltage (between +5 volts d.c. and +7 volts d.c.).
-6V ADJ (potentiometer)	R11	Adjusts -6 volt d.c. line voltage (between -5 volts d.c. and -7 volts d.c.).
+6V (test jack)	TP1	Provides external meter connection to read +6 volt d.c. line voltage.
± (test jack)	TP2	Provides common external meter connection to read polar line voltages.
-6V (test jack)	TP3	Provides external meter connection to read -6 volt d.c. line voltage.

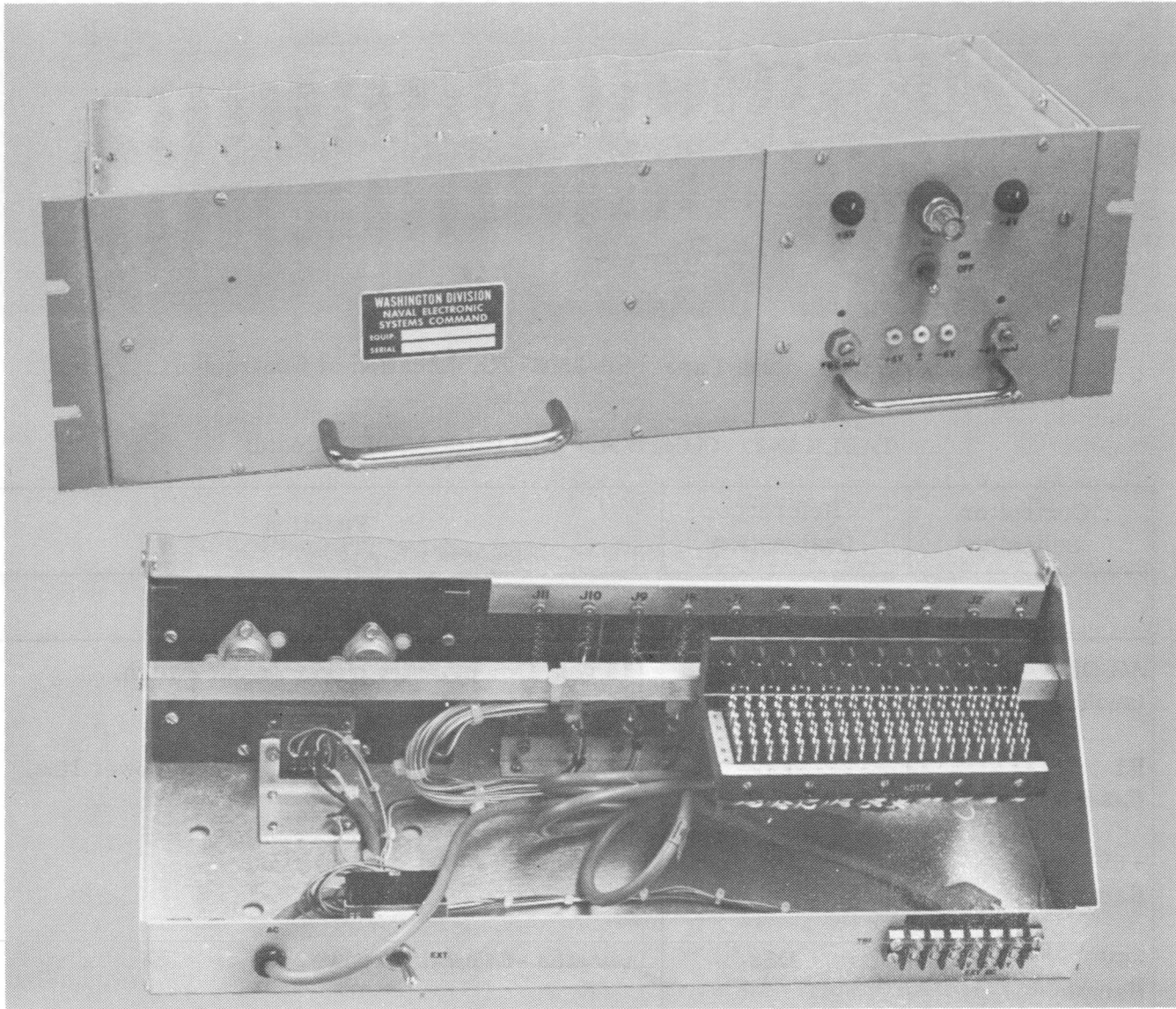

Figure 3-4. Hubbing Repeater TH-83A/FGC, Location of Controls

TABLE 3-1. CONTROLS AND INDICATORS (Contd)

Control or Indicator	Reference Designation	Function
6 VOLT POWER SUPPLY P/O TH-83A FGC (SEE FIGURE 3-4) (Contd)		
(Rear Panel) DC INT-EXT (switch)	S2	Enables selection of ± 6 volt d. c. station battery (EXT) or internal (INT) ± 6 volt d. c.
METER PANEL ME-400/FG (SEE FIGURE 3-5)		
(voltmeter)	M1	Enables operator to patch into communication circuits and measure signal voltage levels. Calibration of scale 10-0-10 volts d. c.

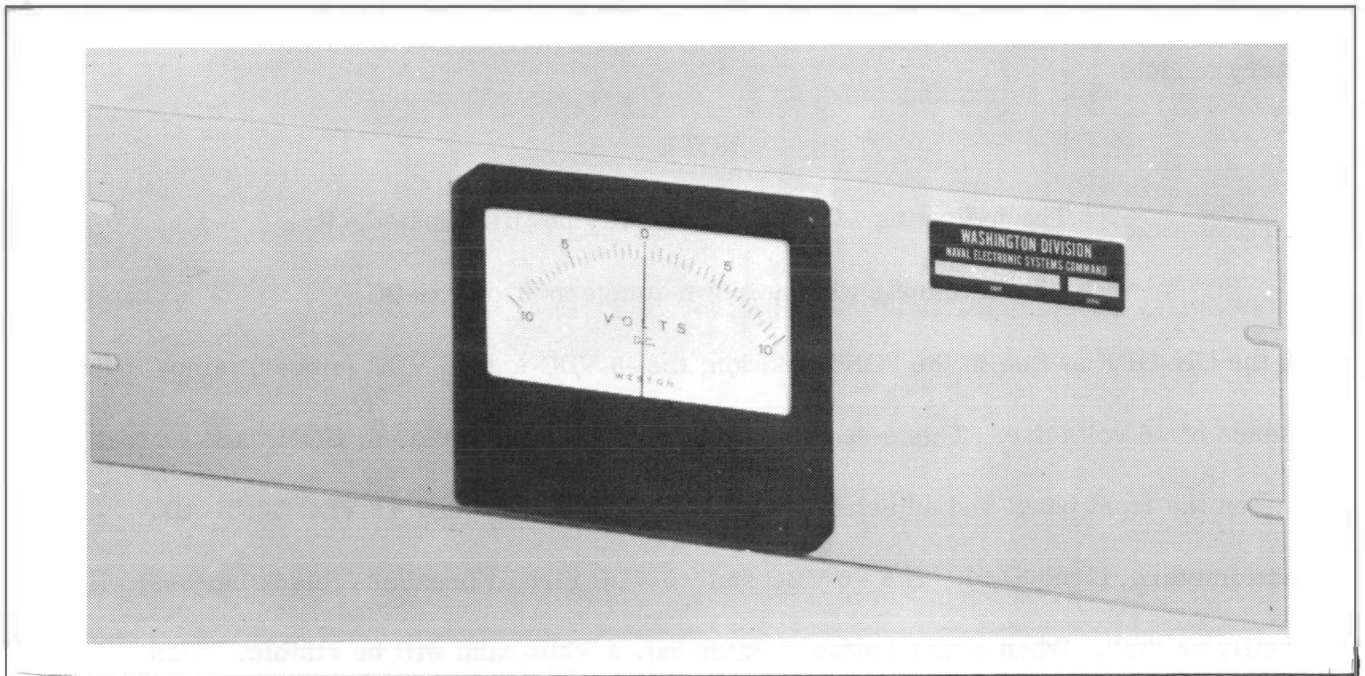

Figure 3-5. Meter Panel, ME-400/FG, Location of Controls

3-3. OPERATING PROCEDURES.

3-4. GENERAL. Operating procedures apply to the 5 Amp Polar Supply, Alarm and Control Panel, and the ± 6 volt d. c. power supply in the Hubbing Repeater. These procedures consist of turn-on and turn-off procedures in addition to general operating procedures. The power supplies are ready for operation immediately after the turn-on procedure is completed.

3-5. 5 AMP POLAR SUPPLY. The 5 Amp Polar Supply requires an operating voltage of 115 volts a. c. , single phase, 50 to 60 Hz. Secure the enclosure in a standard 19-inch rack. Connect the two (2) terminal boards, in the rear of the enclosure, as described in Section II. Place the ON-OFF switch in the "ON" position. This activates the a. c. power input to the primary module.

NOTE

The indicating AC fuse is normally not illuminated. It will illuminate when a blown-fuse condition exists.

With the ON-OFF switch in the "ON" position, the -6 VDC and +6 VDC (amber) lamps indicate presence of ± 6 volts d. c. This voltage may be monitored from the -6, COM, and +6 test points on the front panel and adjusted by the -6 VDC LINE ADJ and +6 VDC LINE ADJ potentiometers, if required. The -6 VDC and +6 VDC circuit breakers (black buttons) will normally be "in". When either button is extended, a white band will be visible. This indicates a "thrown" (over-load) circuit condition.

NOTE

These are "trip-free" thermal-type circuit breakers. They will not reset (lock in) if overload condition remains on-line.

The turn-off procedure is accomplished by placing the ON-OFF switch in the "OFF" position. The -6 VDC and +6 VDC lamps will be extinguished.

3-6. ALARM AND CONTROL PANEL. The Alarm and Control Panel requires an operating voltage of 115 volts a. c. , single phase, 50 to 60 Hz. Secure the enclosure in a standard 19-inch rack. Plug the line cord, in the rear of the enclosure, in a convenient cabinet service outlet. Place the AUD ALARM switch in the "ON" position. This activates the audible alarm bell located within the Alarm and Control Panel enclosure. The VISUAL ALARM (red) lamp is normally extinguished.

NOTE

An illuminated VISUAL ALARM lamp indicates the alarm conditions discussed in Section IV.

The +6V FUSE ALARM (red) and -6V FUSE ALARM (red) lamps are normally "off". An illuminated lamp indicates blown ± 6 volt d. c. line fuse(s). The PRI SUPPLY (green) and STBY SUPPLY (green) lamps are normally illuminated when both 5 Amp Polar Supply modules are turned on. An extinguished condition on either of these lamps indicates that the associated power supply module is turned off. The FUSE lamp, normally "off", will illuminate when an a. c. power failure occurs to the alarm indicators (alarm lamp and alarm bell). With +6 volt d. c. line voltages being supplied as station battery, the LINE VOLTS (POS and NEG) meters will normally indicate +6 volts d. c. and -6 volts d. c. , respectively. The LINE AMPS (POS and NEG) meters will indicate line (load) current.

To check the ± 6 volt d. c. line voltage of the standby power supply module, depress the PUSH TO READ STBY SUPPLY (POS/NEG) push button switch. This transfers the LINE

VOLTS meters from the primary module to the standby module. The LINE VOLTS meters will normally indicate a higher line voltage because of different sampling points.

The turn-off procedure is accomplished by placing the AUD ALARM switch in the "OFF" position. This deactivates the audible alarm bell.

3-7. 6 VOLT POWER SUPPLY, P/O Repeater Telegraph TH-83A/FGC. The 6 volt power supply requires an operating voltage of 115 volts a. c. , single phase, 50 to 60 Hz. Plug the line cord, in the rear of the enclosure, in a convenient service outlet. Place the ON-OFF switch in the "ON" position. This activates the a. c. power input.

NOTE

The indicating AC fuse is normally not illuminated.

It will illuminate when a blown-fuse condition exists.

With the ON-OFF switch in the "ON" position, the +6V and -6V (red) lamps indicate presence of ± 6 volts d. c. This voltage can be monitored from the +6V, \pm , -6 test points on the front panel and adjust by the +6V ADJ and -6V ADJ potentiometers, if required.

The turn-off procedure is accomplished by placing the ON-OFF switch in the "OFF" position. The +6V and -6V lamps will be extinguished.

3-8. OPERATOR'S MAINTENANCE.

3-9. GENERAL. Operator's maintenance is any procedure which is performed within the capability of an operator and is limited to procedures governing inspection, cleaning, adjustment, and minor parts replacement without the use of special tools and test equipment.

3-10. INSPECTION AND CLEANING. A periodic inspection of the facility should be made to assure proper operation of the equipment. Each rack-mounted panel should be checked to ensure that it is in good mechanical condition. Gain access to the rear of the panel by opening the rear cabinet door. Inspect the rear connectors and terminals for good electrical connections and condition of wiring. A periodic cleaning schedule should be followed to prevent the accumulation of dust on operating surfaces. After inspection, ensure that all cabinet panels and doors are replaced securely to prevent entry of dust.

3-11. ADJUSTMENTS. The ammeters and voltmeters, on the Alarm and Control Panel, have a zero-centering adjust screw located below the meter face. This adjustment is used to center the meter pointer.

a. 5 AMP POLAR SUPPLY (PP-6521/FG). The 5 Amp Polar Supply is designed to provide ± 6 volts d. c. To adjust the voltage, use a d. c. voltmeter, and proceed as follows:

- (1) Place the ON-OFF switch in the "ON" position. The AC fuse should be extinguished; - 6 VDC and +6 VDC lamps should be illuminated.
- (2) Insert the test leads of d. c. voltmeter in +6 and COM test points on front panel.
- (3) Unlock the +6 VDC LINE ADJ locknut and using a blade-type screwdriver, turn the +6 VDC LINE ADJ potentiometer. Voltage should vary from between +5 volts to +7 volts.
- (4) Set the +6 VDC LINE ADJ potentiometer to a point where d. c. voltmeter indicates +6 volts. Lock the locknut.
- (5) Insert the test leads of d. c. voltmeter in -6 and COM test points on front panel.
- (6) Repeat steps (3) and (4), except, set the -6 VDC LINE ADJ potentiometer. Indications should be same as in step (3).

b. 6 VOLT POWER SUPPLY (P/O TH-83A/FGC). The 6 volt power supply is designed to provide ± 6 volts d. c. To adjust the voltage, use a d. c. voltmeter, and proceed as follows:

- (1) Place the AC ON-OFF switch in the "ON" position. Fuse F1 should be extinguished; +6 V and -6V lamps should be illuminated.
- (2) Insert the test leads of d. c. voltmeter in +6V and +(d. c. common) test points on front panel.
- (3) Unlock the +6V ADJ locknut and using a blade-type screwdriver, turn the +6V ADJ potentiometer. Voltage should vary from between +4 volts to more than 6 volts (typically 6.3 volts).

(4) Set +6V ADJUST potentiometer to a point where d. c. voltmeter indicates 6 volts.

(5) Insert the test leads of d. c. voltmeter in -6V and \pm (d. c. common) test points on front panel.

(6) Repeat steps (3) and (4), except, set the -6V ADJUST potentiometer. Indications should be same as in step (3).

3-12. TROUBLESHOOTING. Operator's troubleshooting should be limited to replacement of defective lamps or blown fuses.

3-13. MINOR PARTS REPLACEMENT. Minor parts replacement covers only parts whose replacement does not require internal alignment or complex adjustment. To replace a blown fuse, press and turn fuseholder cap counterclockwise and remove from panel. Remove blown fuse from holder and replace. Insert fuseholder into panel, press and turn clockwise until seated firmly.

SECTION IV

MAINTENANCE AND REPAIR

4-1. GENERAL.

4-2. The maintenance and repair instruction contained in this section apply to the components of the Low-Level Technical Control Equipment. This section consists of circuit analysis, preventive maintenance procedures, minimum performance tests, troubleshooting procedures, and repair and replacement procedures. Section VI of this manual contains schematic diagrams of the components which compose the equipment. These diagrams are included as detailed reference for use when performing troubleshooting and maintenance procedures. The location and listing of component parts are contained in Section V of this manual.

4-3. CIRCUIT ANALYSIS.

4-4. PATCH PANEL (SB-3189A/FGC). (See figures 6-1 and 6-2.) The Patch Panel is mounted in a 19-inch wide rack. The four horizontal rows of 26 jacks are terminated on two terminal blocks for connections as required. MON, LINE, EQUIP 1, and EQUIP 2/MISC designate the four rows when used in a low-level configuration and LPG 1, LPG 2, SET 1, and SET 2 when used in a high-level mode.

4-5. 5 AMP POLAR SUPPLY (PP-6521/FG). (See figure 6-3.) The 5 Amp Polar Supply is mounted in a 19-inch wide rack. The power supply consists of two separate ± 6 volt d.c. modules in a single enclosure assembly, each rated at 5 amperes. One module serves as the primary power source and the other as a standby. The front panel of each module contains: a

115 volt a. c. fuse/indicator lamp; a. c. on-off switch; and, two d. c. voltage indicator lamps, line adjusts, and circuit breakers (one each for the -6 volt and +6 volt sections). Test points for measuring ± 6 volt d. c. are also provided on the front panel. Two terminal blocks are mounted on the rear of the enclosure to connect 115 volt a. c. input and ± 6 volt d. c. output voltages and sensor circuits.

The basic polar power module contains one common, dual-secondary, step-down transformer, T1. The positive and negative supplies are identical in operation, therefore, only the positive section will be discussed. The secondary output of T1 is fed to rectifiers CR8 and CR9. Their output becomes the common leg of the supply. Transformer T1 has a center-tapped secondary and is fed to filter capacitor C5 and also to the series regulator transistors Q6 and Q7, and the series regulator control transistor, Q8. Bias for Q6, Q7, and Q8 is provided by rectifiers CR4 and CR5, and is filtered by resistor R11 and capacitor C6. Bias voltage regulation is controlled by CR2, a 7.5 volt unidirectional (zener) diode. Transistor Q2 and variable resistor R13 set the operating point of the series regulator control circuit. Adjustment of R13 will control the output voltage between +5 volts d. c. and +7 volts d. c.

Transistor Q1 senses the power module output voltage at the Alarm and Control Panel. As line voltage decreases, because of circuit loading, forward bias on Q1 decreases which allows more forward bias to the series regulator control transistor Q8. CR1 and R14 provide a feedback to the sensing loop when output failures occur between the power module and the Alarm and Control Panel.

4-6. ALARM AND CONTROL PANEL (P/O PP-6521/FG). (See figure 6-4.) The Alarm and Control Panel is mounted in a 19-inch wide rack. The Alarm and Control Panel provides both visual and audible alarms. The alarm system consists of a "steady-on" visual alarm lamp, DS3, and an audible alarm (bell) B1, which are common to the voltage sensors of the primary and standby power supply modules. Switches S4 and S5, located at the rear of the Alarm and Control Panel, are provided to allow deactivation of the unused voltage sensor circuit. For example, if the standby module is turned off (only the primary module is on-line) the voltage sensor circuit associated with the standby module will activate and cause the alarms to operate. By operating S5 to the "OFF" position, this function is removed. When, and if, the situation is reversed (standby module on-line and primary module off-line) the alarm conditions are also reversed and S4 must be operated to the "OFF" position and S5 to the "ON" position.

The audible and visual alarms will also be activated by a blown line (+6 volt d. c.) fuse. This function cannot be deactivated by any control and will remain activated until the blown fuse is located and replaced.

A front-panel mounted switch, S1, is provided to turn off the audible (bell) alarm during an alarm condition caused by activation of any of the alarm functions. In this situation, the VISUAL ALARM lamp remains illuminated and will continue to be until:

- a. The malfunction is corrected in the blown fuse circuit.
- b. The alarm voltage sensor is removed from the circuit by either S4 or S5.

The indicator circuits consist of: PRI SUPPLY and STBY SUPPLY lamps, DS1 and DS2; +6V FUSE ALARM and -6V FUSE ALARM lamps, DS4 and DS5; FUSE lamp, F1; POS LINE VOLTS/LINE AMPS meters, M1 and M2; and NEG LINE VOLTS/LINE AMPS meters, M3 and M4. Lamps DS1 and DS2 indicate the presence of the ± 6 volt d. c. outputs from each power supply module. Each lamp directly indicates the on- or off-line condition of its associated module. Lamps DS4 and DS5 are activated by the blown fuse alarm circuit. These lamps are provided to indicate the cause of the alarm condition and isolate it to the affected buss. A blown fuse indication for the local 115 volt a. c. to the Alarm and Control Panel is provided by fuse/ indicator lamp F1. Voltmeters, M1 and M3, and ammeters, M2 and M4, provide visual indication of the polar line voltages and currents. The LINE VOLTS meters directly read the positive and negative voltages furnished by the power supply module which is on-line. The LINE AMPS meters directly read the positive and negative currents on-line. The PUSH TO READ STBY SUPPLY switches, S2 and S3, allow monitoring of the polar voltage outputs of both power supply modules. This function does not transfer the power supply modules on- and off-line, but merely indicates their output voltage condition.

4-7. FUSE PANEL (SB-3503/FG.) (See figure 6-5). The Fuse Panel mounts in a 19-inch wide rack. The Fuse Panel provides up to 26 each +6-volt fused circuits for use on Signal, Step, Mark Hold, Step Inhibit, and Control Relays, as required. The fuses are equipped with alarm contacts making it possible to wire in the indicator lamps to provide visual indication of a blown fuse. The fuse panels can be used in the high-level mode. The indicator lamp must be changed for high-level use. It may be replaced with a type NE-2 lamp with a series 100K ohm resistor for high level use. The lamp socket will accommodate either lamp without modification. External cable connections are made directly to the fuse holders and ballast lamp terminals, as required.

4-8. HUBBING REPEATER (TH-83A/FGC). (See figures 6-6 thru 6-9.) The Hubbing Repeater mounts in a 19-inch wide rack. The Hubbing Repeater allows the interfacing of a single digital polar mark plus signal source to various separate outputs. Signal inputs, outputs, and hub connections are brought out to a terminal block mounted on the rear of the Hubbing Repeater. The enclosure assembly contains 10 printed circuit plug-in boards mounted behind a removable front panel. Also contained within the enclosure is a +6 volt d.c. power supply which is removable as a separate unit. The power supply provides all the power required to drive the 10 plug-in Hubbing Repeater cards; however, switch S1 is mounted on the rear of the enclosure to select +6 volt d. c. station battery, if required. The plug-in printed circuit boards are not prewired for any set input/output hubbing configuration, but are only brought out to the rear terminal block, as previously mentioned. The input/output hubbing configuration is left to the option of the installing activity.

The +6 volt polar power supply provides power for the 10 printed circuit boards and their respective loads. The power supply consists of two identical regulated supplies fed by a common input transformer, T1. The positive section differs from the negative section only by designation of the battery common connection. Therefore, only the positive section will be discussed.

Rectifier CR 1 is a conventional bridge whose output is fed to the pi filter consisting of capacitors C1 and C2, and resistor R1. R1 is also the principal current limiting element for fail-safe operation on shorted conditions. The regulator is a series type, with transistor Q3 as the variable series element. Q2 acts as a complementary-amplifier stage with its collector providing the base current for Q3. Base current for Q2 is provided by the emitter current of Q1. By tapping the Q1 emitter resistor R6, the output voltage can be manually adjusted. The regulator will maintain this voltage (within 3.5%) between no load (0.0 amperes) and full load (\cong 1/2 amperes). CR2 provides the reference bias for Q1. R5 acts as a "bleeder" to establish a useable threshold for the regulator.

In a typical sequence, Q3 is "on" to the extent that the collector of Q2 is providing its base current. Q2, in turn, is controlled by its base current, which is determined by a voltage divider consisting of R4, R6, Q1 and R3. The base of Q1 is clamped at approximately 7.5 volts by CR2. So long as the net voltage (difference between the voltage at the top of R4 and the center arm of R6) is positive in respect to the emitter of Q2, Q2 will be forward-biased, causing it to supply base current (forward bias) to Q3.

When the load increases, the voltage at the top of R4 decreases, and since the voltage at the center arm of R6 remains the same (the base of Q1 remains clamped by CR2) the net

forward bias on Q2 increases. Q2 is driven further into conduction and Q3 follows. The internal resistance of Q3 decreases and more voltage is supplied to the load until a stable condition occurs once again. This action continues within the design limits of the unit.

Each of the Hubbing Repeater cards consists of two identical circuits. The circuit consisting of Q1 thru Q8 will be discussed.

As its name indicates, the overall action of the card is to "repeat" whatever signal is applied to its input and to provide an isolated hubbing, or combining, point for more than one input. In the absence of input signal or with a steady positive mark input, the output is +6 volts d.c. The circuit changes state only on negative transitions of a polar signal. The polar signal fed to pin L is coupled thru R2 to the bases of Q1 and Q2. (R4 is usually adjusted for zero volts at test point TP2 and has no effect on the circuit in this condition.) In its steady-state condition, Q1 is conducting and Q2 is cut-off. When the input signal goes negative, Q1 is cut-off and Q2 is driven into conduction. Since the base currents of Q3 and Q4 are supplied by Q1 and Q2, Q3 will now be cut-off and Q4 will conduct. The current thru R7 will change direction accordingly and the voltage appearing at the cathode of CR1 will change from its steady-state position to negative. CR1 will now conduct, causing a negative voltage to appear at the bases of Q5 and Q6. From here, the action of Q1, Q2, Q3, and Q4 is repeated.

The capacitors in the circuit are used for waveshaping. R8 and R9 are forward biasing resistors to compensate for different characteristics of various transistors.

The negative signal which appears at the anode of CR1 is fed from the card at pin H. This signal can be used to drive up to nineteen other similar circuits, that is by strapping all of the hubbing points together, the signal fed to pin L will appear at the outputs of all 10 cards in the Hubbing Repeater.

4-9. PREVENTIVE MAINTENANCE

4-10. Preventive maintenance consists of inspection, cleaning procedures, and minimum performance tests required to maintain the proper equipment operating level. Since each of the component's operating environment may vary, it is impractical to set forth a specific preventive maintenance schedule; however, it is suggested that a preventive maintenance schedule be made up and followed in order to prevent equipment failure due to dust, dirt, condensation, and other accumulating type materials.

4-11. GENERAL SCHEDULING REQUIREMENTS. At periodic intervals, the Low-Level Technical Control Equipment should be thoroughly inspected and cleaned externally and internally. Accumulating type materials should be removed with a soft brush, rag, vacuum cleaner, or suitable solvent. If removed, the components should be operated in accordance with the minimum performance tests contained in paragraph 4-12 through 4-14.

4-12. 5 AMP POLAR SUPPLY MINIMUM PERFORMANCE TEST. Test the 5 Amp Polar Supply as follows:

- a. Insert the test leads of a voltmeter (Simpson 260 VOM or equivalent) in the +6 and COM test points on the front panel of the primary polar power module.
- b. Install a 3 ohm, 12 watt resistor between the +6 volt output terminal (5, 6, or 7) and battery common (8, 9, or 10) on barrier strip A1TB1 at the rear of the polar supply enclosure.
- c. Place the ON-OFF switch in the "ON" position.
- d. Observe the voltmeter; indication should be $+6 \pm 0.5$ volts d. c.

- e. Place the ON-OFF switch in the "OFF" position.
- f. Remove the test leads from the +6V and COM test points and insert them in the -6V and COM test points.
- g. Remove the 3 ohm, 12 watt resistor from the +6 volt output terminal and battery common on A1TB1 and install the resistor between the -6 volt output terminal (12, 13, or 14) and battery common (8, 9, or 10).
- h. Repeat step (c).
- i. Observe the voltmeter; indication should be -6 ± 0.5 volts d.c.
- j. Repeat step (e).
- k. Remove the 3 ohm, 12 watt resistor from A1TB1.
- l. The minimum performance load-test for the standby polar power module shall be accomplished by repeating steps (a) thru (k).

4-13. ALARM AND CONTROL PANEL MINIMUM PERFORMANCE TEST. Test the Alarm and Control Panel as follows:

- a. Place the PRIMARY ALARM switch and STBY ALARM switch, on the rear panel of the Alarm and Control enclosure, in the "ON" position.
- b. Place the AUD ALARM switch, on the front panel, in the "OFF" position.
- c. Plug the a.c. power cord into a convenient 115 volt service outlet. The VISUAL ALARM lamp should illuminate; audible alarm should not be activated at this time.
- d. Place the AUD ALARM switch in the "ON" position; VISUAL ALARM lamp should remain illuminated and audible alarm should sound.

- e. Place the PRIMARY ALARM switch in the "OFF" position; visual alarm and audible alarm should remain activated.
- f. Place the PRIMARY ALARM switch in the "ON" position and the STBY ALARM switch in the "OFF" position; visual and audible alarms should remain activated.
- g. Place the PRIMARY ALARM switch in the "OFF" position. With both alarm arming switches "OFF", the visual and audible alarms should deactivate.

4-14. HUBBING REPEATER MINIMUM PERFORMANCE TEST. Test the Hubbing Repeater as follows:

- a. Before proceeding with the minimum performance test complete the adjustment procedure referenced in par. 3-11b (Section III).
- b. Remove the front cover of the Hubbing Repeater enclosure.
- c. Remove the PC Extender Board from guide.
- d. Remove PC Board A1 from guide and insert the PC Extender Board. Insert PC Board A1 in the extender.

NOTE

Each PC Board (A1 thru A10) has two identical channels.

- e. Disconnect (patch-out) any signal being fed to and from PC Board A1.
- f. Connect oscilloscope probe (d. c. input) or voltmeter test leads between TP2 on PC Board A1 and \pm (d. c. common) test point on front panel of power supply. Voltage indicator should be 0.0 volts. (See figure 6-6).

CAUTION

Do not break potentiometer R4 seal to correct slight error.

- g. Connect oscilloscope (d.c. input) or voltmeter to TP4 on PC Board A1.

Voltage indicator should be a steady +6 volts d.c.

h. With test equipment connected as in step (g), connect jumper from TP1 on PC Board A1 to +6V test point on front panel of power supply. Voltage indicator should be a steady +6 volts d.c.

- i. Repeat step (h), except, connect jumper from TP1 to -6V test point.

Voltage indication should be -6 volts d.c.

- j. Connect oscilloscope to TP1.

k. Connect output of audio oscillator to TP1. Set frequency to 37.5 Hz (75 baud). Adjust output level, as observed on oscilloscope, to approximately 12 volts p-p.

l. Connect oscilloscope to TP4. A modified (slightly sloping) ± 6 volt waveform should be indicated. (See figure 6-6.)

NOTE

The waveforms shown in figure 6-6 are typical of those associated with low-level mod kits manufactured by Teletype Corp. In the illustrated example, observe that the input signal has marking bias, therefore the output signal has marking bias. The signals observed in step (l) should be symmetrical (zero bias).

m. Reduce output level of audio oscillator to 6 volts p-p. Output waveform observed at TP4 should remain as in step (l).

n. Continue to reduce output level of audio oscillator, while observing waveform at TP4. Spacing bias should be present and increase as signal input is reduced.

CAUTION

Spacing bias can be corrected by adjusting R4. However, it is suggested that this adjustment remain sealed and used for emergency purposes only.

o. With the audio oscillator output level at 12 volts p-p, connect oscilloscope to TP3. Waveform observed should be negative halves of symmetrical square wave (slightly sloped) with small positive component. (See figure 6-6).

p. Repeat steps (f) thru (o) for other channel (TP5, TP6, TP7, and TP8) on PC Board A1.

q. Repeat steps (d) thru (p) for PC Boards A2 thru A10.

4-15. REPAIR AND REPLACEMENT.

4-16. Repair and replacement procedures for the Low-Level Technical Control

Equipment are performed in a straightforward manner and require no unusual techniques.

All components are removable from the front of the cabinets. When replacing parts, refer to Section V for the location and listing of component parts.

4-17. TROUBLESHOOTING.

4-18. Trouble is located best by making a visual check first and then checking the system functions. If only one function is inoperative, the circuits concerned solely with that function should be investigated. If two or more functions are inoperative, it is likely that the fault lies in a common circuit. When a malfunction is observed in the equipment, it is advisable to make a quick check of all functions before attempting to localize the fault.

4-30. Troubleshooting procedures are outlined in tabular form in table 4-1. Before troubleshooting the user should be familiar with the theory of operation and operating instructions. When performing troubleshooting procedures, refer to the diagrams provided in Section VI and to the part location data contained in Section V.

Table 4-1. TROUBLESHOOTING

Trouble	Probable Cause	Remedy
HUBBING REPEATER TH-83A/FGC		
+6V lamp not illuminated	a) Power cord not plugged in. b) Fuse F1 blown. c) Lamp DS1 burned out.	a) Plug in cord. b) Replace fuse. c) Replace lamp.
-6V lamp not illuminated	a) Power cord not plugged in. b) Fuse F1 blown. c) Lamp DS2 burned out.	a) Plug in cord. b) Replace fuse. c) Replace lamp.
No <u>+</u> 6 volt signal output at TP4	No <u>+</u> 6 volt signal input.	Check for signal input at TP1 on appropriate PC Board.
Ballast lamps RT1 thru RT4 illuminated	a) Short in PC Board. b) Short in ± 6 volt output wiring (usually <u>not</u> a transistor).	a) Substitute another PC Board. b) Correct short on output signal line.

TABLE 4-1. TROUBLESHOOTING (Contd)

Trouble	Probable Cause	Remedy
5 AMP POLAR SUPPLY PP-6521/FG		
No +6 volt or -6 volt output	<ul style="list-style-type: none"> a) No. a. c. power. b) Fuse F1 blown. 	<ul style="list-style-type: none"> a) Restore a. c. power. b) Replace fuse.
Low +6 volt or -6 volt output	<ul style="list-style-type: none"> a) Series regulator control card (SRC) defective. b) Series regulator control transistor Q5 or Q8 defective. 	<ul style="list-style-type: none"> a) Replace card. b) Replace transistor.
High +6 volt or -6 volt output	<ul style="list-style-type: none"> a) Series regulator control card (SRC) defective. b) Series regulator control transistors, Q3, Q4, and Q5 for -6volts d. c. , or Q6, Q7, and Q8 for +6 volts d. c. 	<ul style="list-style-type: none"> a) Replace card. b) Replace transistors.
ALARM AND CONTROL PANEL P/O PP-6521/FG		
No system alarm, visual or audible	<ul style="list-style-type: none"> a) No a. c. power. b) Fuse F1 blown. c) Alarm system not properly armed. 	<ul style="list-style-type: none"> a) Plug in cord. b) Replace fuse. c) Refer to Section III for proper arming of alarm system switches S4 and S5.
No audible alarm; visual alarm normal	<ul style="list-style-type: none"> a) AUD ALARM switch S1 "OFF". b) Bell defective. 	<ul style="list-style-type: none"> a) Reset S1 to "ON". b) Replace bell.
No visual alarm; audible alarm normal	Lamp DS3 burned out.	Replace lamp.

Table 4-1. TROUBLESHOOTING (Contd)

Trouble	Probable Cause	Remedy
ALARM AND CONTROL PANEL P/O PP-6521/FG (Contd)		
<p>+6V FUSE ALARM or -6V FUSE ALARM lamps not illuminated</p> <p>Standby power will not transfer to line when primary power fails</p> <p>Primary power will not transfer to line when standby power fails</p>	<p>Lamps DS4 or DS5 burned out.</p> <p>a) Standby power module not on. b) Transfer relay K4 defective. c) Standby transfer Relay Control Board (RCB) defective .</p> <p>a) Primary power module not on. b) Transfer relay K1 defective. c) Primary transfer Relay Control Board (RCB) defective.</p>	<p>Replace lamp(s).</p> <p>a) Activate standby power module . b) Replace relay . c) Replace CR2 and/or Q2.</p> <p>a) Activate primary power module. b) Replace relay . c) Replace CR1 and/or Q1.</p>

SECTION V

PARTS LIST

5-1. INTRODUCTION.

5-2. This section contains the lists and illustrations of the maintenance parts for the Low-Level Technical Control System. The lists are presented in tabular form and contain the information described in the following paragraphs. Table 5-1 lists the major assemblies and applicable figures.

5-3. REFERENCE DESIGNATION.

5-4. The reference designation or index number column lists the electrical parts alphabetically by circuit reference designation (where applicable) and the mechanical parts by index number. The parts are identified on the associated illustrations by the corresponding reference designations.

5-5. PART NUMBER. The part numbers listed in this column are those of the prime contractor, the design vendor, or the government agency through which it is promulgated.

5-6. DESCRIPTION. The description column contains the basic name of the part and any descriptive information necessary for its identification.

5-7. MANUFACTURER'S CODE. This column lists the code assigned by the Federal Supply Code for Manufacturer's Cataloging Handbooks H4-1 and H4-2. A listing of applicable Manufacturer's Codes will be found in table 5-11.

5-8

5-8. QUANTITY PER ASSEMBLY. The quantity per assembly column indicates the total quantity of a particular part used in the assembly in which it is listed.

TABLE 5-1. MAJOR ASSEMBLIES

Figure Number	Part Number	Description
5-1		Patch Panel SB-3189A/FGC
5-2 thru 5-4		5 Amp Polar Supply PP-6521/FG
5-5, 5-6		Alarm and Control Panel P/O PP-6521/FG
5-7		Fuse Panel SB-3503/FG
5-8 thru 5-11		Hubbing Repeater TH-83A/FGC
5-12		532 Pair IDF J-2943/FG
5-13		Meter Panel ME-400/FG
5-14		3200 Pair Frame J-2885/UG
5-15		Cabinet CY-597A/UG

TABLE 5-2. PATCH PANEL SB-3189A/FGC, PARTS LIST (SEE FIGURE 5-1)

Ref Designation	Part Number	Description	Mfr Code	Qty Per Assy
E1, E2	99A	Strip, designation	64959	2
E3	99B	Strip, designation	64959	1
J1 thru J26	280C	Jack, telephone	64959	104
E4, E5	N5935-221-0925	Mounting, jack	64959	2
TB1, TB2	156A	Block, terminal	64959	2

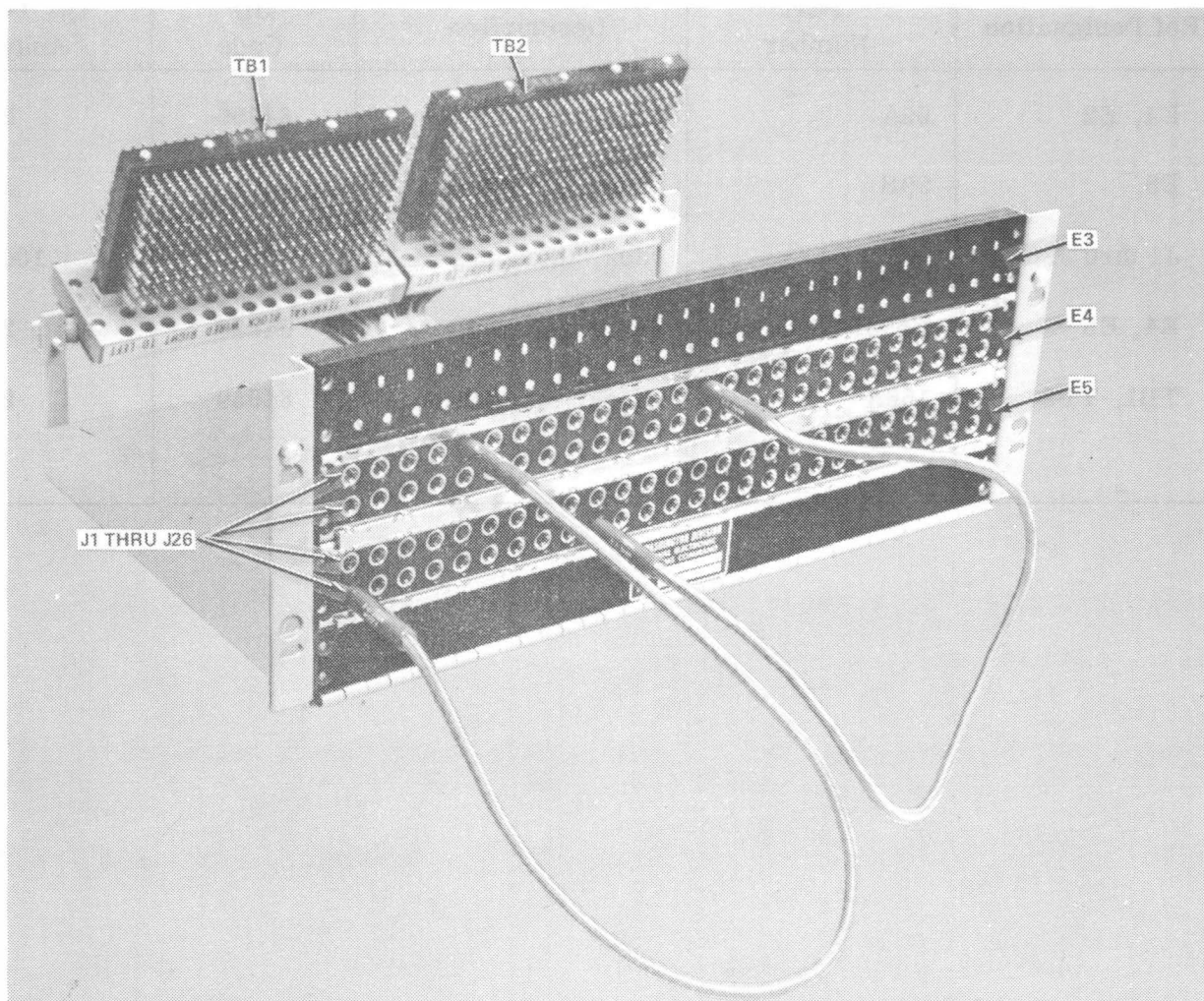

Figure 5-1. Patch Panel SB-3189A/FGC, Location of Components

TABLE 5-3. 5 AMP POLAR SUPPLY PP-6521/FG, PARTS LIST

Ref Designation	Part Number	Description	Mfr Code	Qty Per Assy
POLAR POWER MODULE (SEE FIGURE 5-2)				
A1J1, A1J2	00-5009-012-189-001	Connector, receptacle	02660	2
A1J3	26-4401-165	Connector, receptacle	02660	1
C1, C4, C6, C7	Type CE71	Capacitor, 2000 mfd, 40 Vdc	_____	4
C3, C5	Type CE71	Capacitor, 33,000 mfd, 15 Vdc	_____	2
CB1, CB2	MS 25244-5	Breaker, circuit	79404	2
CR6, CR7, CR8, CR9	JAN1N1614	Diode	_____	4
DS1, DS2	GE-344	Lamp, 10 Vdc	08806	2
F1	3AG-1A	Fuse	71400	1
Q3, Q4, Q5, Q6, Q7, Q8	JAN2N3055	Transistor	_____	6
R4, R13	RV4LAYSA252A	Potentiometer, 2.5K, 2W	_____	2
S1	81024GB	Switch, DPST	04009	1
T1	E-36-6	Transformer, TF5RX02	01838	1
TP1	MS-16108F	Jack, test, yellow	49956	1
TP2	MS-16108F	Jack, test, black	49956	1
TP3	MS-16108F	Jack, test, red	49956	1

TABLE 5-3. 5 AMP POLAR SUPPLY PP-6521/FG, PARTS LIST (Contd)

Ref Designation	Part Number	Description	Mfr Code	Qty Per Assy
XDS1, XDS2	7528	Holder, lamp, amber	72619	2
XF1	HKL	Holder, fuse	71400	1
XQ3, XQ4, XQ5, XQ6, XQ7, XQ8	MK-15	Holder, transistor	15873	6
POLAR SUPPLY ENCLOSURE (SEE FIGURE 5-3)				
A1P1, A1P2	26-4501	Connector, plug	02660	2
A1TB1, A1TB2	140Y-14	Strip, barrier	71785	2
PRINTED CIRCUIT BOARD SRC-A1 (SEE FIGURE 5-4)				
C2	CHR09A1NC-103KL	Capacitor, .01 mfd, 200 Vdc	—	1
CR1, CR3	JAN1N485B	Diode	—	2
CR2	JAN1N755A	Diode	—	1
CR4, CR5	JAN645	Diode	—	2
Q1, Q2	JAN2N1613	Transistor	—	2
R1, R3	RCR20G102JM	Resistor, 1K, ±5%, 1/2W	81349	2
R2, R5	RCR20G561JM	Resistor, 560Ω, ±5%, 1/2W	81349	2
R6, R9	RCR20G152JM	Resistor, 1.5K, ±5%, 1/2W	81349	2
R7	RCR20G101JM	Resistor, 100Ω, ±5%, 1/2W	81349	1

TABLE 5-3. 5 AMP POLAR SUPPLY PP-6521/FG, PARTS LIST (Contd)

Ref Designation	Part Number	Description	Mfg Code	Qty Per Assy
R8	RCR20G331JM	Resistor, 330 Ω , $\pm 5\%$, 1/2W	81349	1
R10	RCR20G272JM	Resistor, 2.7K, $\pm 5\%$, 1/2W	81349	1
R11	RCR32G270JM	Resistor, 27 Ω $\pm 5\%$, 1W	81349	1
R12	RCR20431JM	Resistor, 430 Ω , $\pm 5\%$, 1/2W	81349	1
R14	RCR20101JM	Resistor, 100 Ω , $\pm 5\%$, 1/2W	81349	1

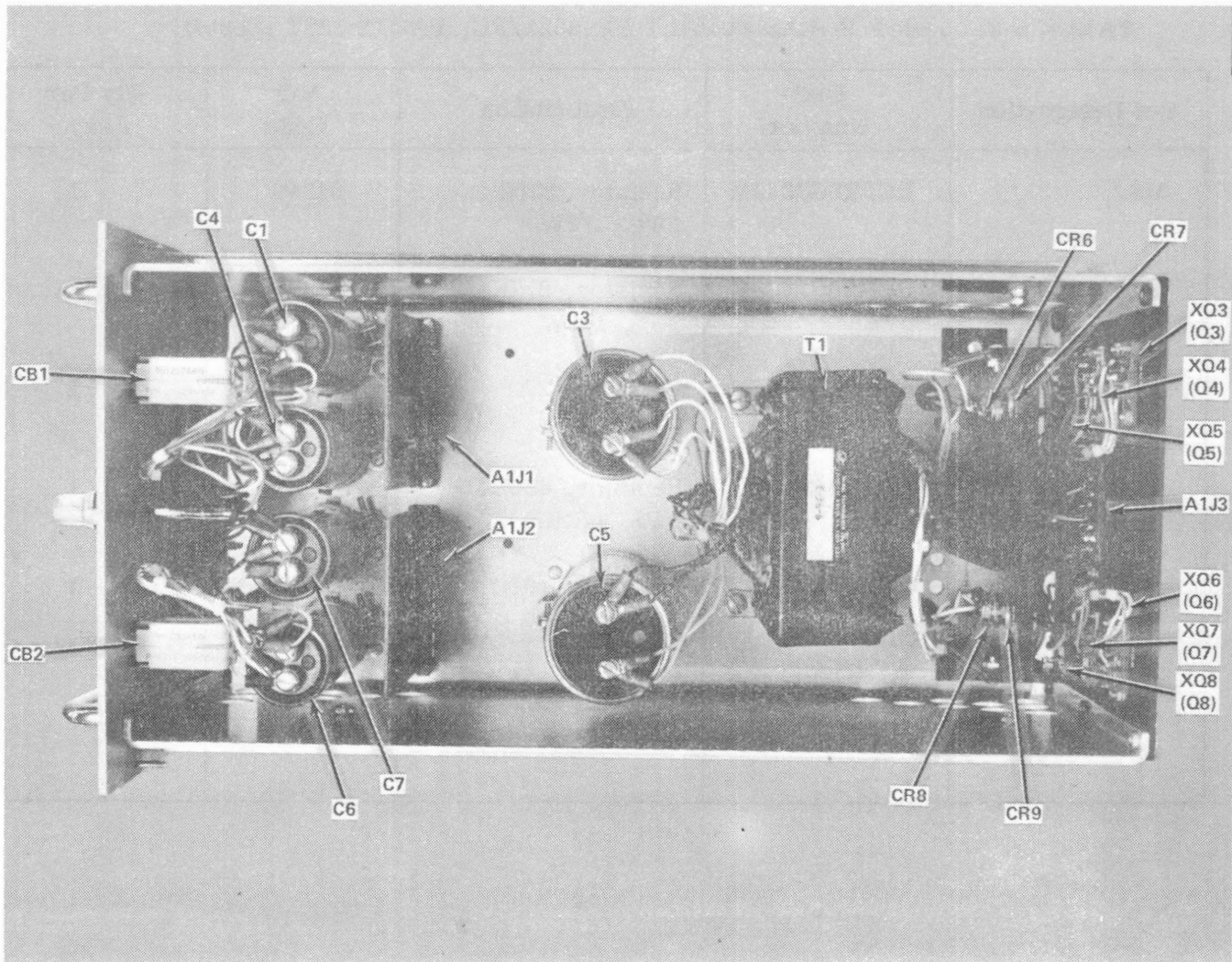

Figure 5-2. Polar Power Module P/O PP-6521/FG, Location of Components

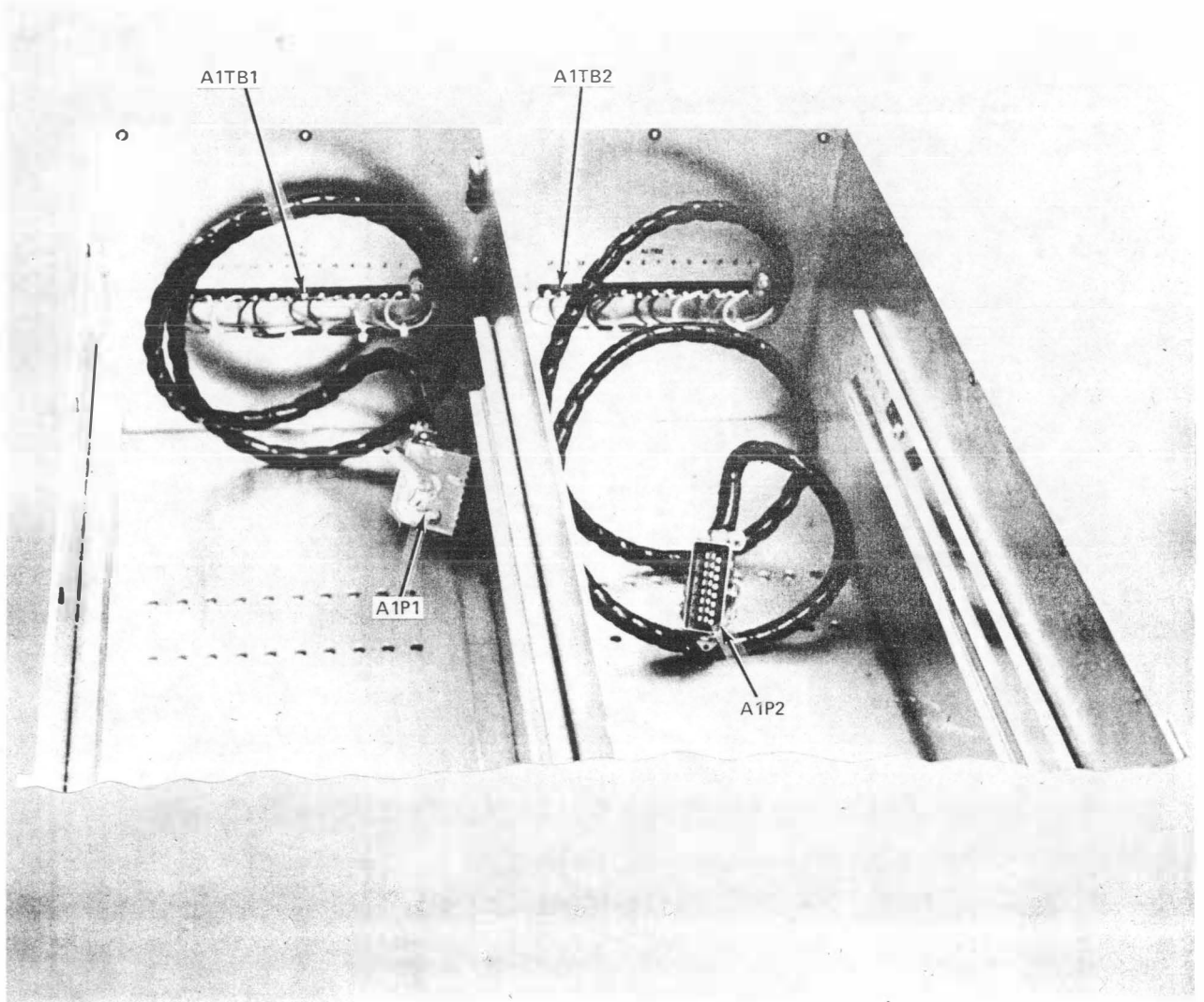

Figure 5-3. Polar Supply Enclosure P/O PP-6521/FG, Location of Components

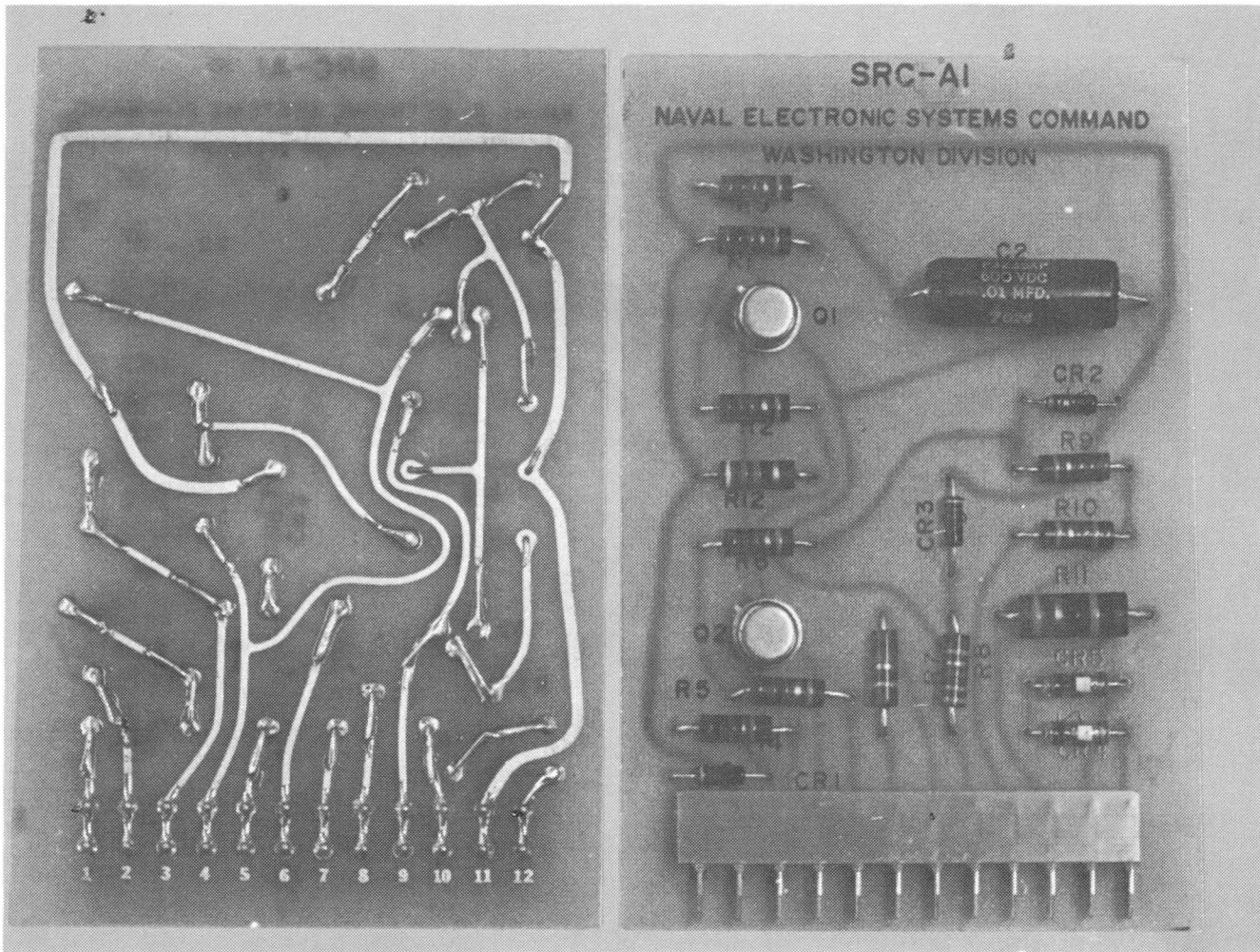

Figure 5-4. Printed Circuit Board SRC-A1 P/O PP-6521/FG, Location of Components

TABLE 5-4. ALARM AND CONTROL PANEL P/O PP-6521/FG, PARTS LIST

Ref Designation	Part Number	Description	Mfr Code	Qty Per Assy
ALARM AND CONTROL PANEL ASSEMBLY (SEE FIGURE 5-5)				
A2TB1, A2TB2	140Y-12	Strip, barrier	71785	1
B1	156	Bell, alarm, 12 Vac	19557	1
DS1, DS2, DS3	Type 53	Lamp, 12 Vdc	08806	3
DS4, DS5	507-3905	Lamp, 6 Vdc, 40ma	72619	2
E1	HO48F	Relief, strain	72653	1
F1	3AG-1A	Fuse	71400	1
K1, K4	KHP17DL11	Relay, 12 Vdc	77342	2
K2, K3	KHP17D11	Relay, 6 Vdc	77342	2
M1, M3	1227	Voltmeter, 0-10 Vdc	55026	2
M2, M4	1227	Ammeter, 0-10 amps	55026	2
S1, S4, S5	1185	Switch, SPST	00175	3
S2, S3	556	Switch, pushbutton	83330	3
T1	21F10	Transformer	96256	1
TB3	3006	Strip, terminal	71785	1
W1	17236-SV	Cord, ac power	70903	1
XDS1	169-0410- 1191-301	Holder, lamp, red	72619	1
XDS2, XDS3	169-0410- 1191-302	Holder, lamp, green	72619	2
XDS4, XDS5	7538	Holder, lamp, red	72619	2

TABLE 5-4. ALARM AND CONTROL PANEL P/O PP-6521/FG, PARTS LIST (Contd)

Ref Designation	Part Number	Description	Mfr Code	Qty Per Assy
XF1	HKL	Holder, fuse	71400	1
XK1, XK2, XK3, XK4	9KH1	Socket, relay	77342	4
RELAY CONTROL BOARD RCB-1 (SEE FIGURE 5-6)				
CR1, CR2	JAN1N757	Diode	—	2
Q1, Q2	JAN2N657	Transistor	—	2
R1, R2	RCR07GF103J	Resistor, 1K, ±5%, 1/4W	81349	2

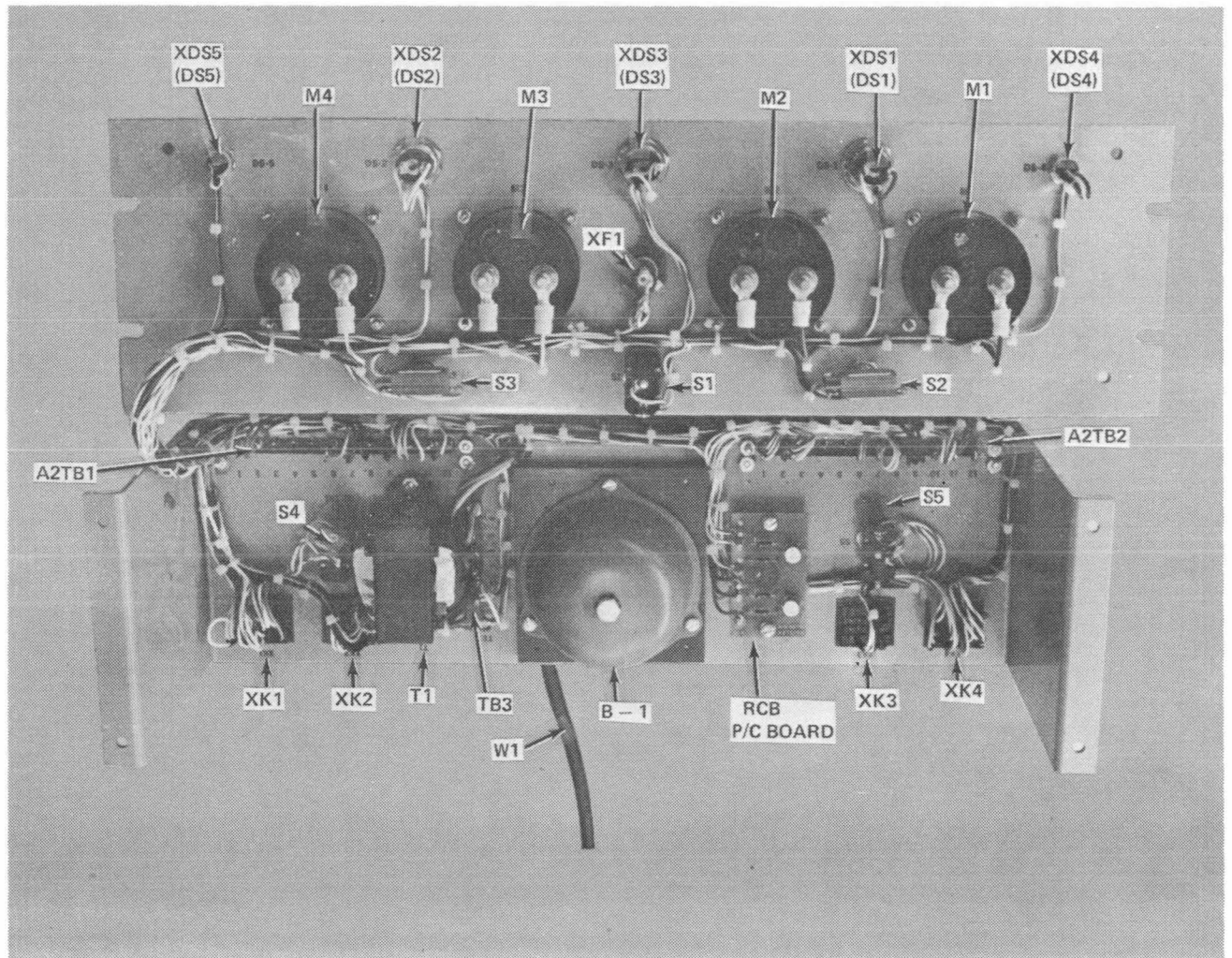

Figure 5-5. Alarm and Control Panel Assembly P/O PP-6521/FG, Location of Components

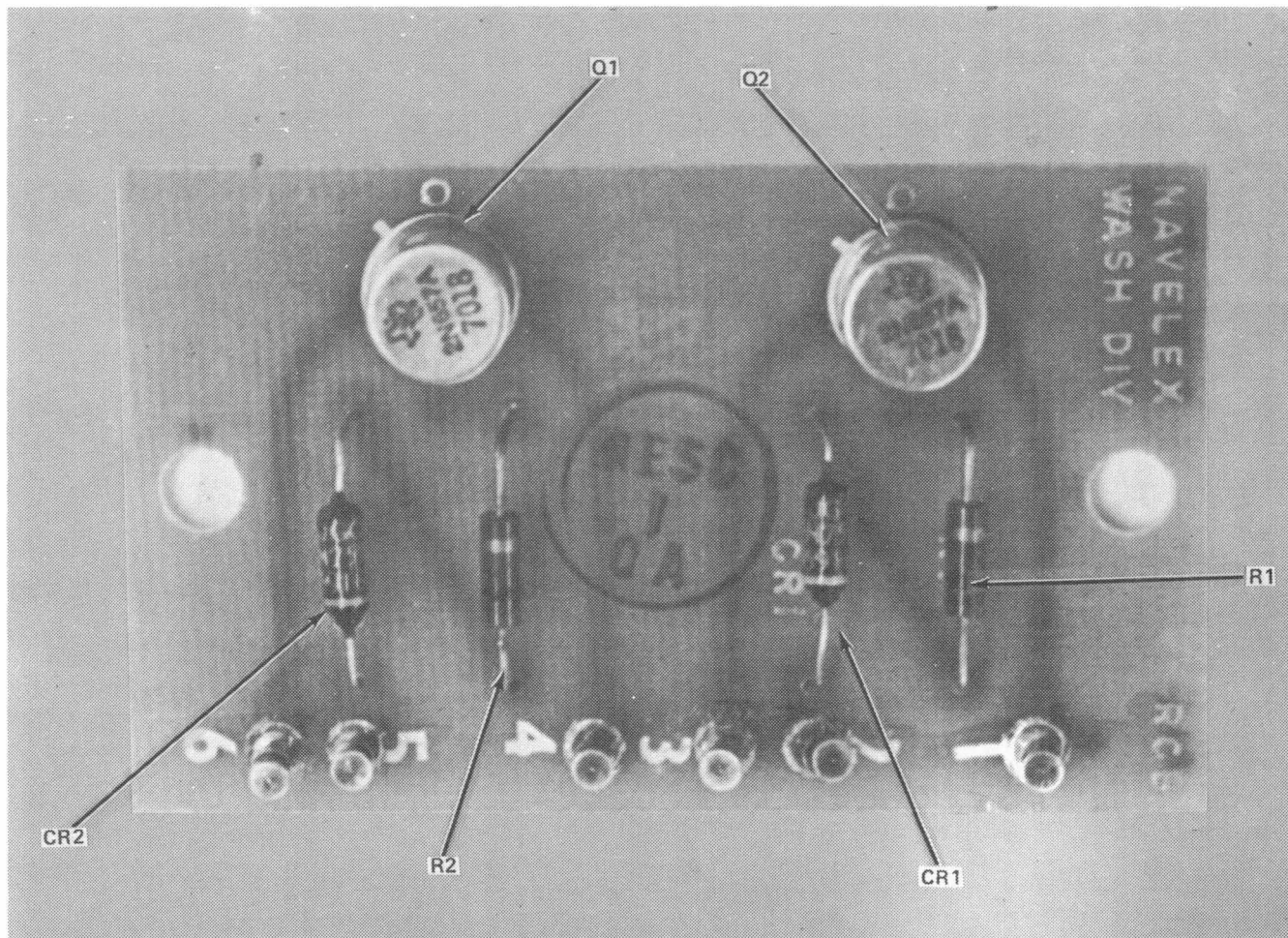

Figure 5-6. Relay Control Board RCB-1 P/O PP-6521/FG, Location of Components

TABLE 5-5. FUSE PANEL SB-3503/FG, PARTS LIST (SEE FIGURE 5-7)

Ref Designation	Part Number	Description	Mfr Code	Qty Per Assy
DS1, DS2	507-3905	Lamp, 6 Vdc	72619	2
F1A thru F26A, F1B thru F26B	GMT(1N5920- 023-2926)	Fuse, 18/100 amp	—	52
XF1A thru XF26A	HLT(1N5920- 968-3238)	Holder, fuse	—	52
XDS1, XDS2	7538	Holder, lamp, red	72619	2

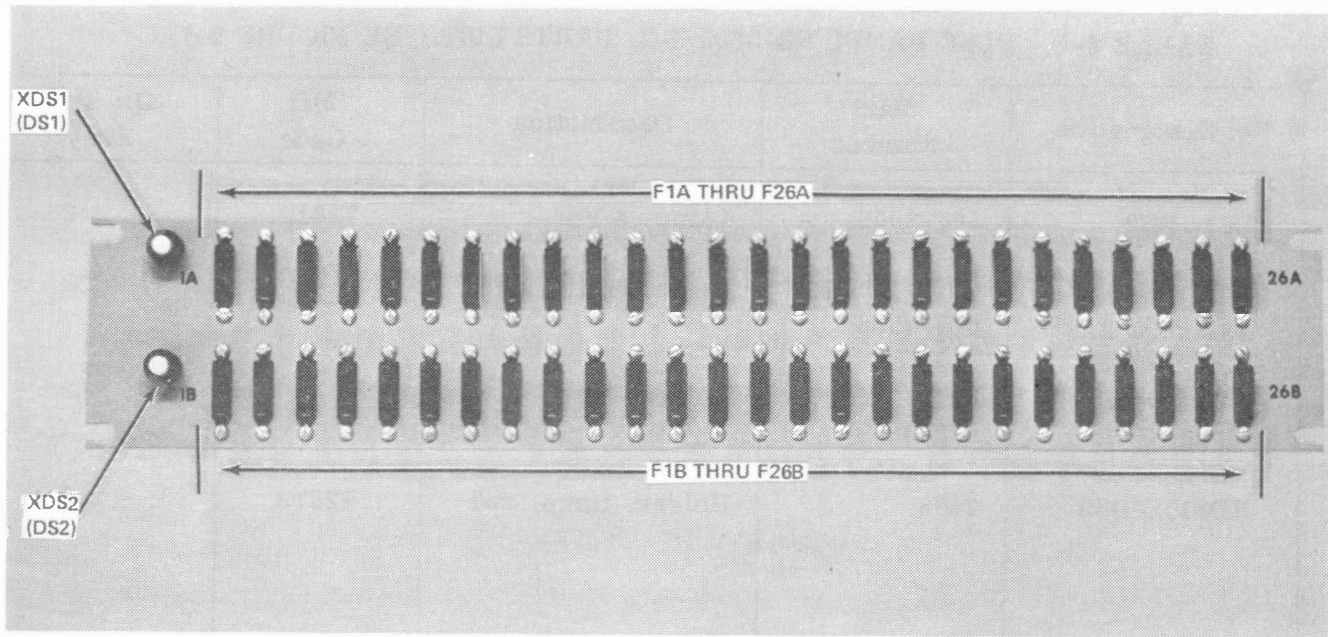

Figure 5-7. Fuse Panel SB-3505/FG, Location of Components

TABLE 5-6. HUBBING REPEATER TH-83A/FGC, PARTS LIST

Ref Designation	Part Number	Description	Mfr Code	Qty Per Assy
REPEATER PANEL ENCLOSURE (SEE FIGURE 5-8)				
E1 thru E22	63-9016-1201-10	Guide, PC	91662	22
E23	HO48F	Relief, stain	72653	1
J1 thru J11	143-018-01-1001	Connector, receptacle	02660	11
J12	26-4200-8S	Connector, receptacle	02660	1
S1	8373K8	Switch, DPDT	27191	1
TB1	140Y-6	Strip, barrier	71785	1
TB2	111	Block, terminal		1
W1	17236-SV	Cord, ac power	70903 Belden	1
PRINTED CIRCUIT BOARD (SEE FIGURE 5-9)				
C1, C2, C6, C7	M39003/01-2332	Capacitor, .047 mfd, 50 Vdc	—	4
C3, C4, C5, C8, C9, C10	M39003/01-2356	Capacitor, 1 mfd, 50 Vdc	—	6
CR1, CR2	JAN1N198	Diode	—	2
E1 thru E16	7717-5N	Pad, transistor mounting	—	16
P1	133-018-43-1001	Connector, plug	02660	1

TABLE 5-6. HUBBING REPEATER TH-83A/FGC, PARTS LIST (Contd)

Ref Designation	Part Number	Description	Mfr Code	Qty Per Assy
Q1, Q4, Q5 Q8, Q9, Q12, Q13, Q16	JAN2N697	Transistor	_____	8
Q2, Q3, Q6 Q7, Q10, Q11, Q14, Q15	JAN2N2905	Transistor	_____	8
R1, R14	RCR07GF622J	Resistor, 6.2K ±5%, 1/4W	81349	2
R2, R15	RCR07GF104J	Resistor, 100K, ±5%, 1/4W	81349	2
R3, R16	RCR07GF473J	Resistor, 47K, ±5%, 1/4W	81349	2
R4, R17	MIL RJ12BP254	Potentiometer, 250K, 1/4W	_____	2
R5, R6, R11, R12, R18, R19, R24, R25	RCR07GF103J	Resistor, 10K, ±5%, 1/4W	_____	8
R7, R20	RCR07GF682J	Resistor, 6.8K, ±5%, 1/4W	81349	2
R8, R21	RCR07GF105J	Resistor, 1Meg, ±5%, 1/4W	81349	2
R9, R22	RCR07GF334J	Resistor, 330K, ±5%, 1/4W	81349	2
R10, R23	RCR07GF154J	Resistor, 150K, ±5%, 1/4W	81349	2
R13, R26	RCR07GF470J	Resistor, 47Ω, ±5%, 1/4W	81349	2

TABLE 5-6. HUBBING REPEATER TH-83A/FGC, PARTS LIST (Contd)

Ref Designation	Part Number	Description	Mfr Code	Qty Per Assy
RT1 thru RT4	CM-8-661	Lamp	71744	4
TP1 thru TP8	3-582118-9	Jack, test, white	02660	8
6 VOLT POWER SUPPLY (SEE FIGURE 5-10)				
C1, C2, C3, C4	Type 39D	Capacitor, 2200 mfd, 25 Vdc	56289	4
DS1, DS2	Type 345	Lamp, 6 Vdc	08806	2
E1, E2	MK15	Kit, mounting, power transistor	04713	2
E3, E4, E5, E6	UMC-16	Clip, mounting	56289	4
F1	3AG-1A	Fuse	71400	1
P1	26-4100-8P	Connector, plug	02660	1
Q3, Q6	JAN2N297A	Transistor	—	2
R1, R12	RH-65	Resistor, 10 Ω , 10W	91637	2
R6, R11	CLU-5011	Potentiometer, 500 Ω 2W, Type AB	44655	2
S1	1185	Switch, SPST	00715	1
T1	TF4RXOIGA 27F10	Transformer	96256	1
TB1, TB2	3008	Strip, terminal	83330	2
TP1, TP3	1501	Jack, test, yellow	831130	2
TP2	1501	Jack, test, white	831130	1
XDS1, XDS2	101-5030- 0931-201	Holder, lamp, red	72619	2

TABLE 5-6. HUBBING REPEATER TH-83A/FGC, PARTS LIST (Contd)

Ref Designation	Part Number	Description	Mfr Code	Qty Per Assy
XF1	HKL	Holder, fuse	71400	1
PRINTED CIRCUIT BOARD TCB-1 (SEE FIGURE 5-11)				
CR1, CR3	MDA 942-5	Rectifier, bridge	04713	2
CR2, CR4	JAN1N3017B	Diode, Zener	_____	2
Q1, Q2, Q4, Q5	JAN2N697	Transistor	_____	4
R2, R7	RCR20GF272J	Resistor, 2.7K, ±5%, 1/2W	81349	2
R3, R8	RCR32GF330J	Resistor, 33Ω, ±5%, 1W	81349	2
R4, R9	RCR20GF152J	Resistor, 1.5K ±5%, 1/2W	81349	2
R5, R10	RCR32GF151J	Resistor, 150Ω, ±5%, 1W	81349	2

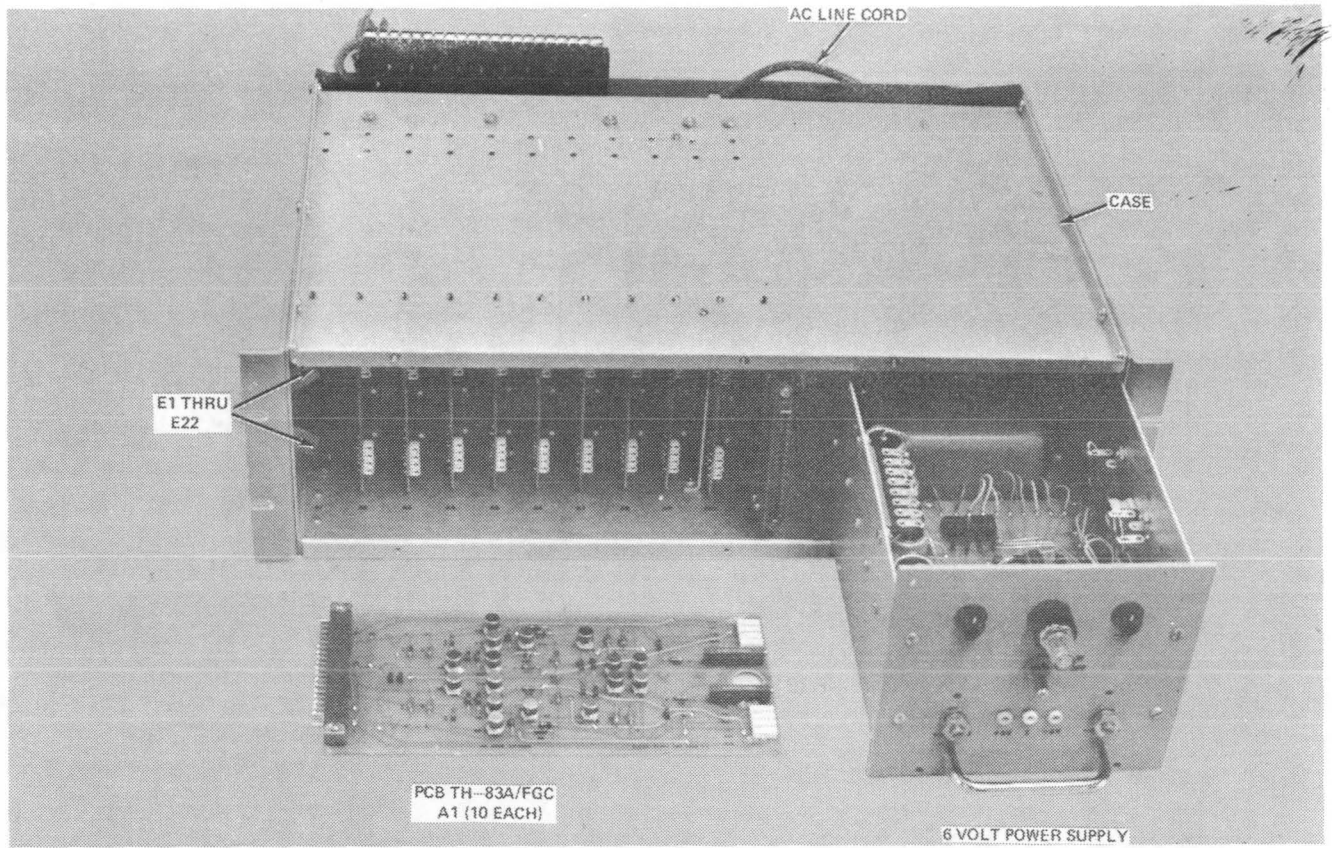

Figure 5-8. Repeater Panel Enclosure P/O TH-83A/FGC, Location of Components

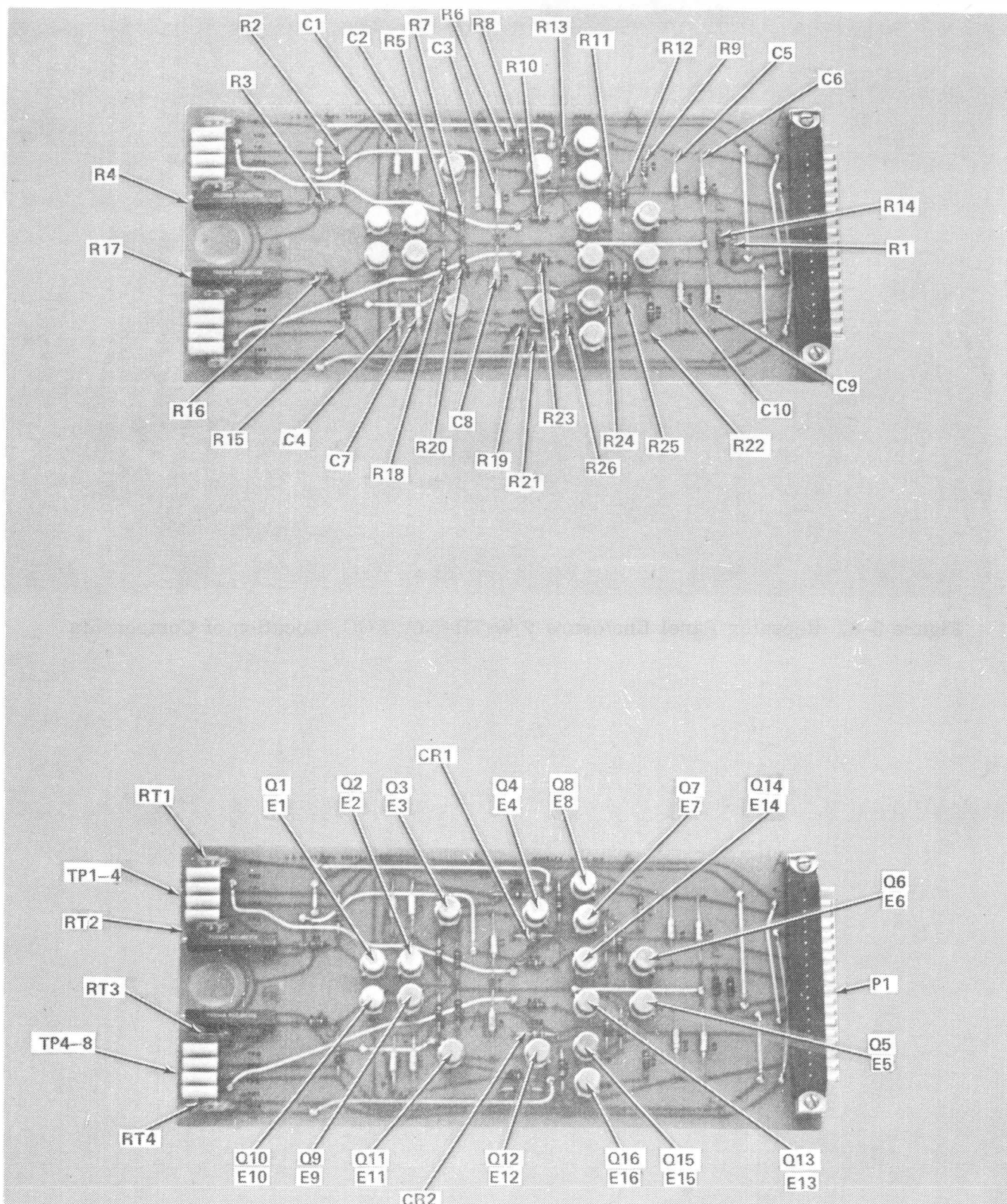

Figure 5-9. Printed Circuit Board P/O TH-83A/FGC, Location of Components

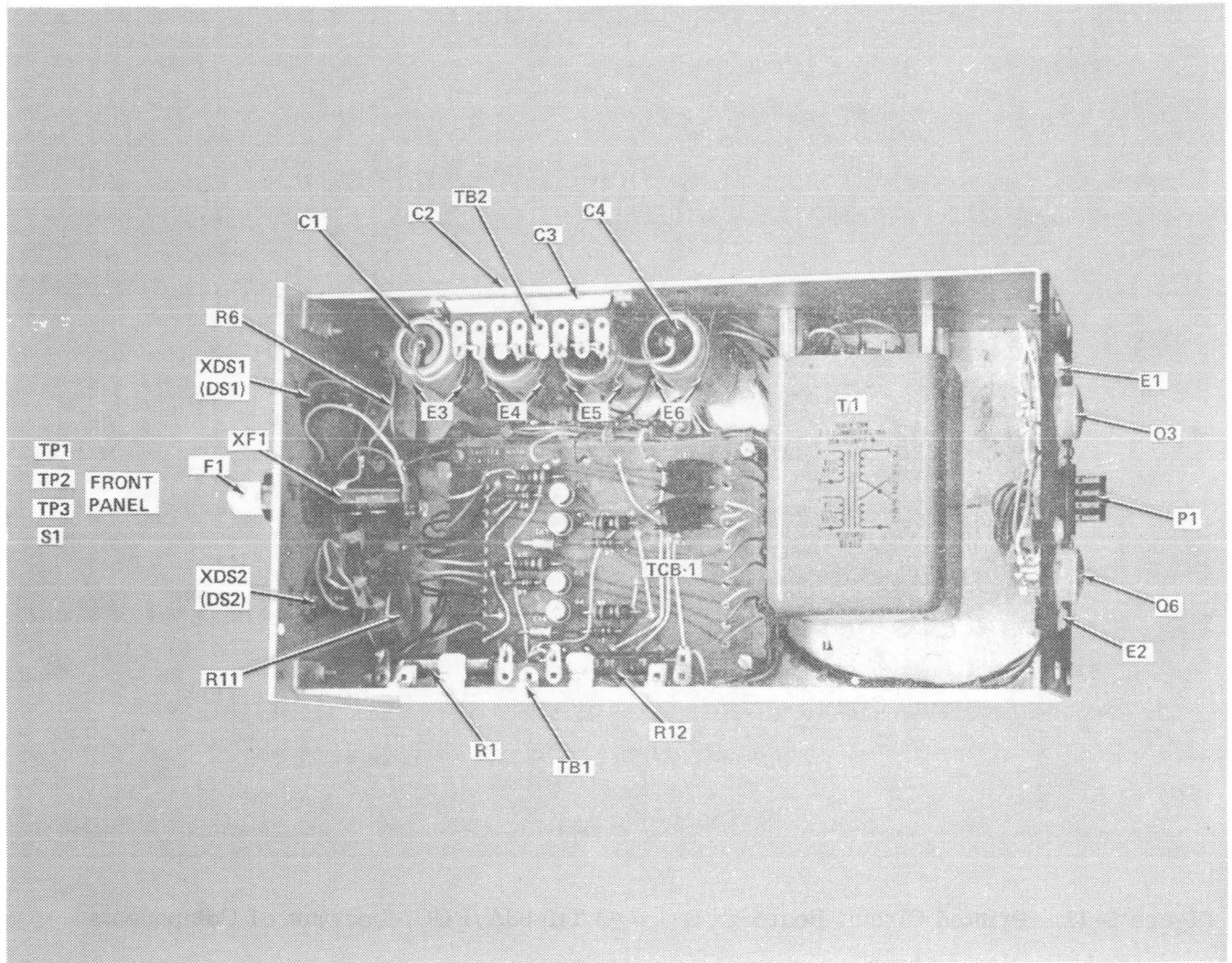

Figure 5-10. 6 Volt Power Supply P/O TH-83A/FGC, Location of Components

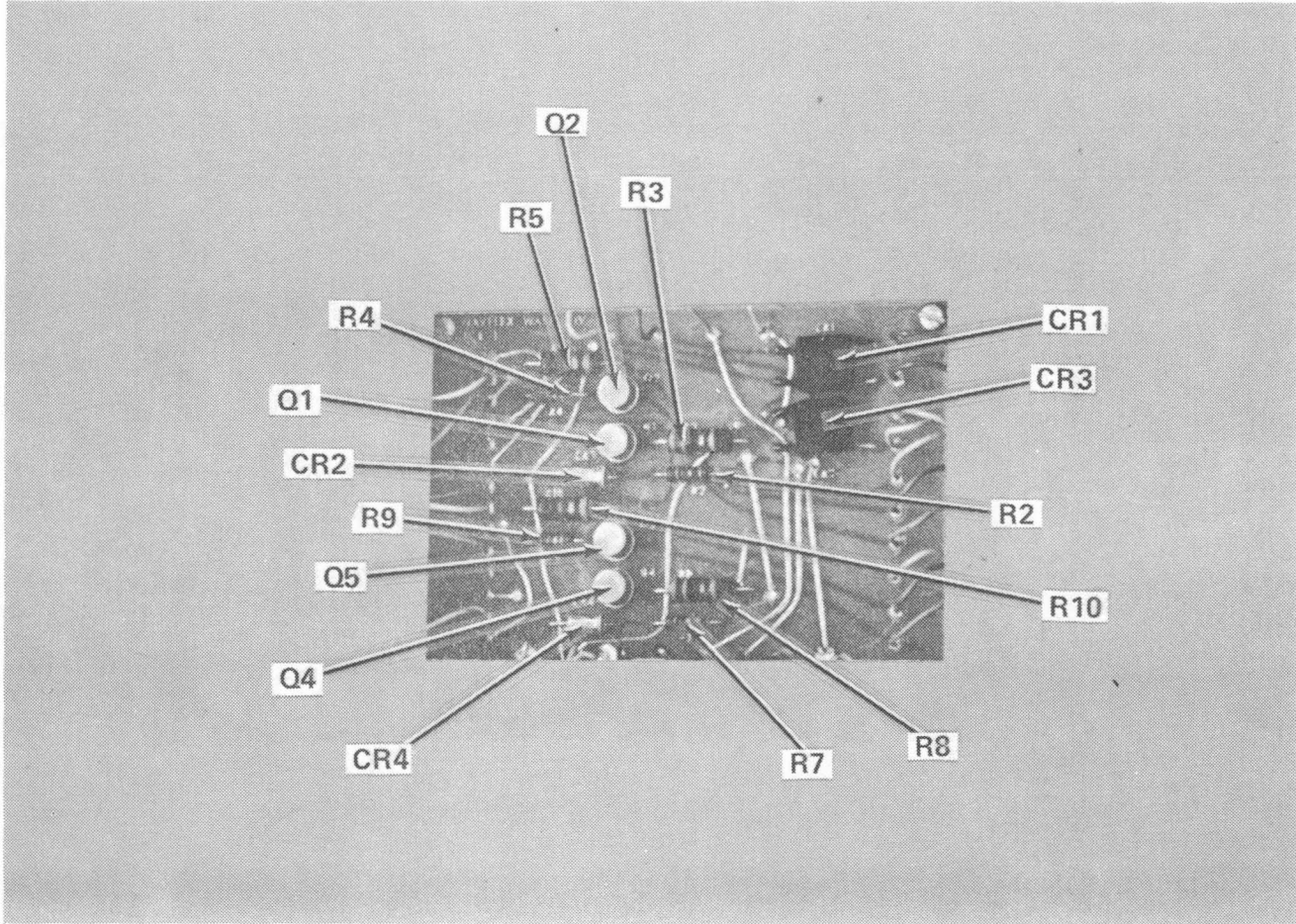

Figure 5-11. Printed Circuit Board TCB-1 P/O TH-83A/FGC, Location of Components

TABLE 5-7. 532 PAIR IDF J-2943/FG, PARTS LIST (SEE FIGURE 5-12)

Ref Designation	Part Number	Description	Mfr Code	Qty Per Assy
TB1 thru TB4	156A	Block, terminal	64959	4

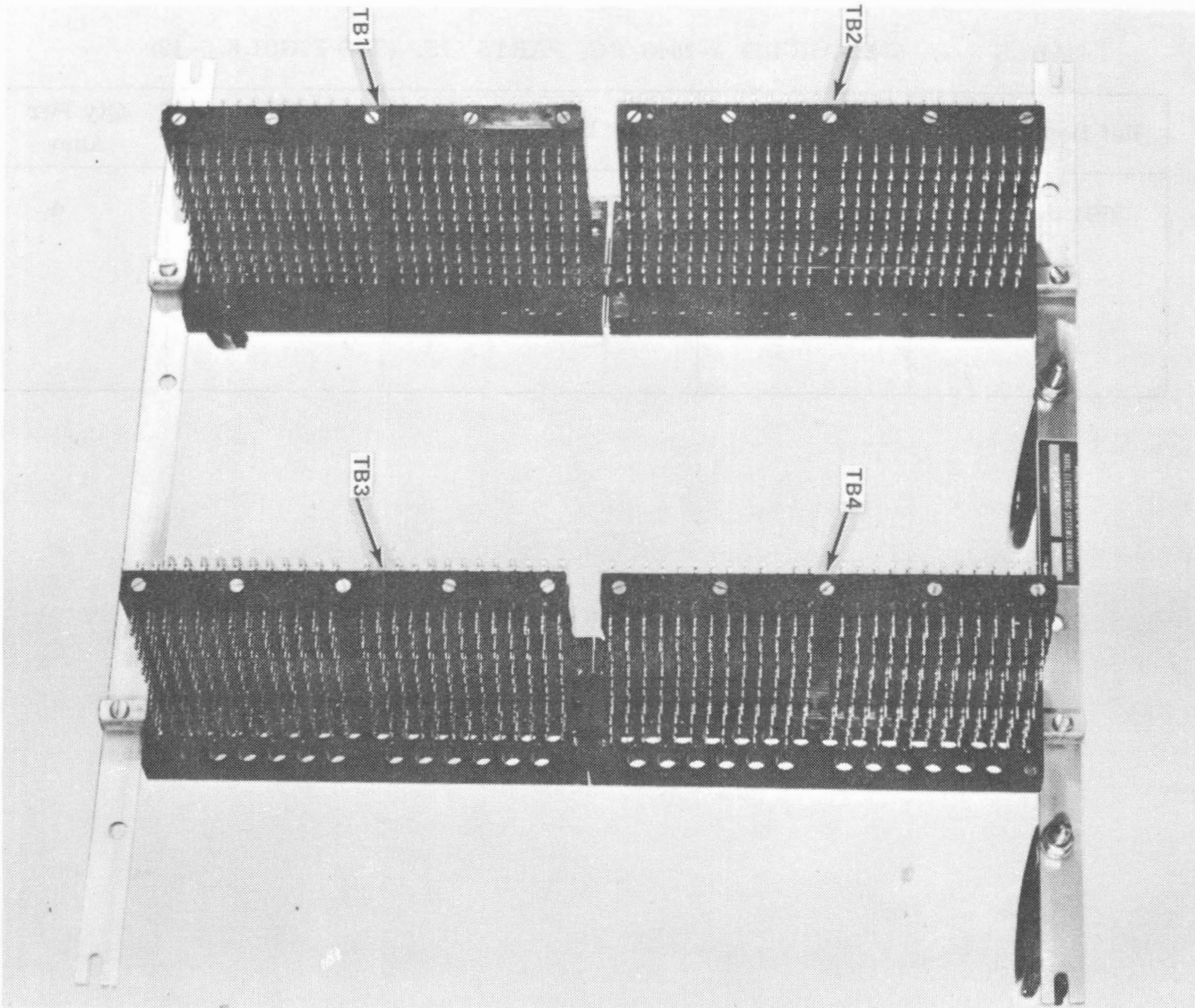

Figure 5-12. 532 Pair IDF J-2943/FG, Location of Components

TABLE 5-8. METER PANEL ME-400/FG, PARTS LIST (SEE FIGURE 5-13)

Ref Designation	Part Number	Description	Mfr Code	Qty Per Assy
M1	268063	Voltmeter, 10-0-10 Vdc, Model 1951	65092	1

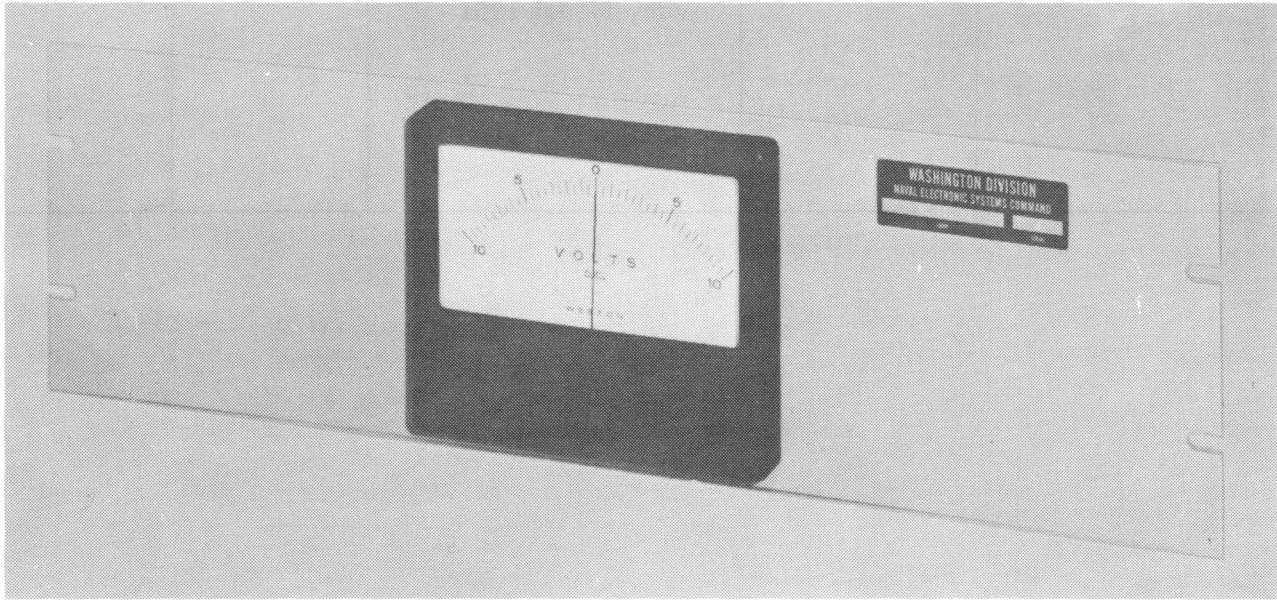

Figure 5-13. Meter Panel ME-400/FG, Location of Components

TABLE 5-9. 3200 PAIR FRAME J-2885/UG, PARTS LIST (SEE FIGURE 5-14)

Ref Designation	Part Number	Description	Mfr Code	Qty Per Assy
TB1 thru TB32	156A	Block, terminal	64959	32

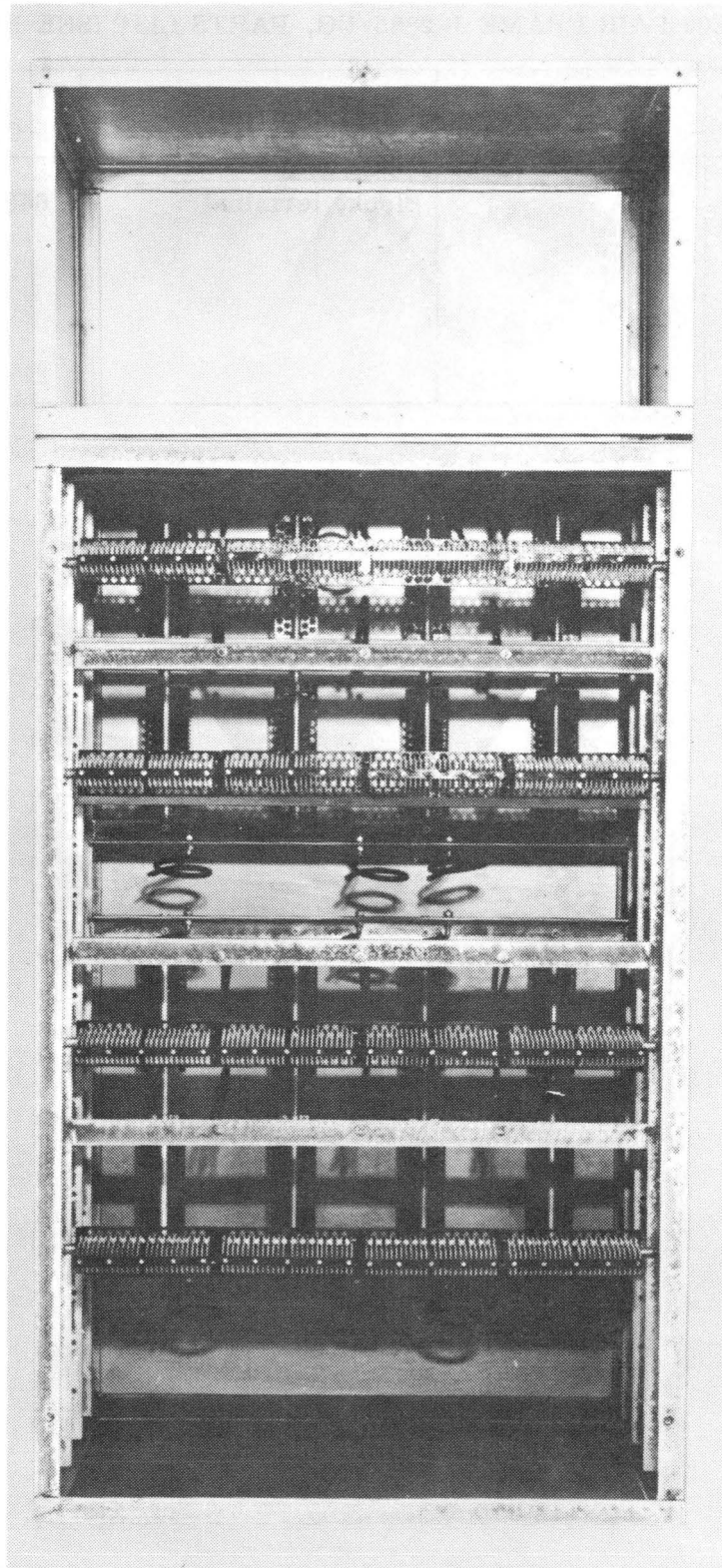

Figure 5-14. 3200 Pair Frame J-2885/UG,
Location of Components

TABLE 5-10. CABINET CY-597A/UG, PARTS LIST (SEE FIGURE 5-15)

Ref Designation	Part Number	Description	Mfr Code	Qty Per Assy
FSN-5975-538-5115		Equipment Cabinet	—	1

TABLE 5-11. MANUFACTURER'S CODE LIST

Code	Name and Address
64959	Western Electric Co., Inc. 83 Maiden Lane New York NY. 10038
02660	Amphenol Corp. 2801 S 25th Avenue Broadview Ill. 60153
79404	Wood CD Electric Co., Inc. Glendale New York
08806	General Electric Co. Miniature Lamp Department Nela Park Cleveland, Ohio 44112
71400	Bussmann Mfg., Division of McGraw & Edison Company 2536 W University St. St. Louis, Missouri 63017
04009	Arrow-Hart and Hegeman Electric Company 103 Hawthorne St. Hartford, Conn. 06106
01838	Signal Electronic and Manufacturing Company New York, New York
49956	Raytheon Company Lexington, Mass. 02173
72619	Dialight Corporation 60 Stewart Avenue Brooklyn, New York 11237
15873	Motorola Incorporated 406 West Main St. Arcade, New York 14009
71785	Cinch Mfg., Co. and Howard B. Jones Division 1026 S. Homan Avenue Chicago, Ill. 60624
81349	Military Specifications Promulgated By Standardization Div. Directorate of Logistic Services DSA
19557	Edwards Company Inc. A Unit of General Signal Corp. 90 Connecticut Avenue Norwalk, Conn. 06852
72653	G. C. Electronics Company A Division of Hydro Metals Inc. 400 S. Wyman Street Rockford, Ill. 61101

TABLE 5-11. MANUFACTURER'S CODE LIST (Contd)

Code	Name and Address
77342	American Machine and Foundry Co. Potter and Brumfield Div. 1200 E. Broadway P. O. Box 522 Princeton, Ind. 47570
55026	Simpson Electric Company Division of American Gage and Machine Company 5200 W. Kinzie St. Chicago, Ill. 60644
00175	Acme Industrial Company 200 N. Laflin Street Chicago, Ill. 60607
83330	Smith Herman H. Inc. 812 Snediker Avenue Brooklyn, New York 11207
96256	Thordarson and Meissner Inc. Electronic Center Mt. Carmel, Ill. 62863
70903	Belden Corp 415 S. Kilpatrick Chicago, Ill. 60644
91662	Elco Corp Maryland Road and Computer Avenue Willow Grove, Pa. 19090
27191	Cutlerhammer Inc. Power Distribution and Control Division 4201 N. 27th Street Milwaukee, Wis. 53216
71744	Chicago Miniature Lamp Works 4433 Ravenswood Avenue Chicago, Ill. 60640
56289	Sprague Electric Company North Adams, Mass. 01247
04713	Motorola Semiconductor Products Inc. 5005 East McDowell Road Phoenix, Arizona 85008
91637	Dale Electronics Inc. P. O. Box 609 Columbus, Nebr. 68601
44655	Ohmite Manufacturing Company 3601 W. Howard Street Skokie, Ill. 60076
00715	Specalties Manufacturing Company 8821 Fenkel Detroit, Michigan 48238

TABLE 5-11. MANUFACTURER'S CODE LIST (Contd)

Code	Name and Address
65092	Weston Instruments Inc. Weston Instruments Division 614 Frelinghuysen Avenue Newark, New Jersey 07114

SECTION VI

DRAWINGS

6-1. INTRODUCTION.

6-2. This section contains all schematic and wiring diagrams to be used for maintenance. These diagrams are referred to in Section IV for circuit tracing, and for location of test points and adjustable components.

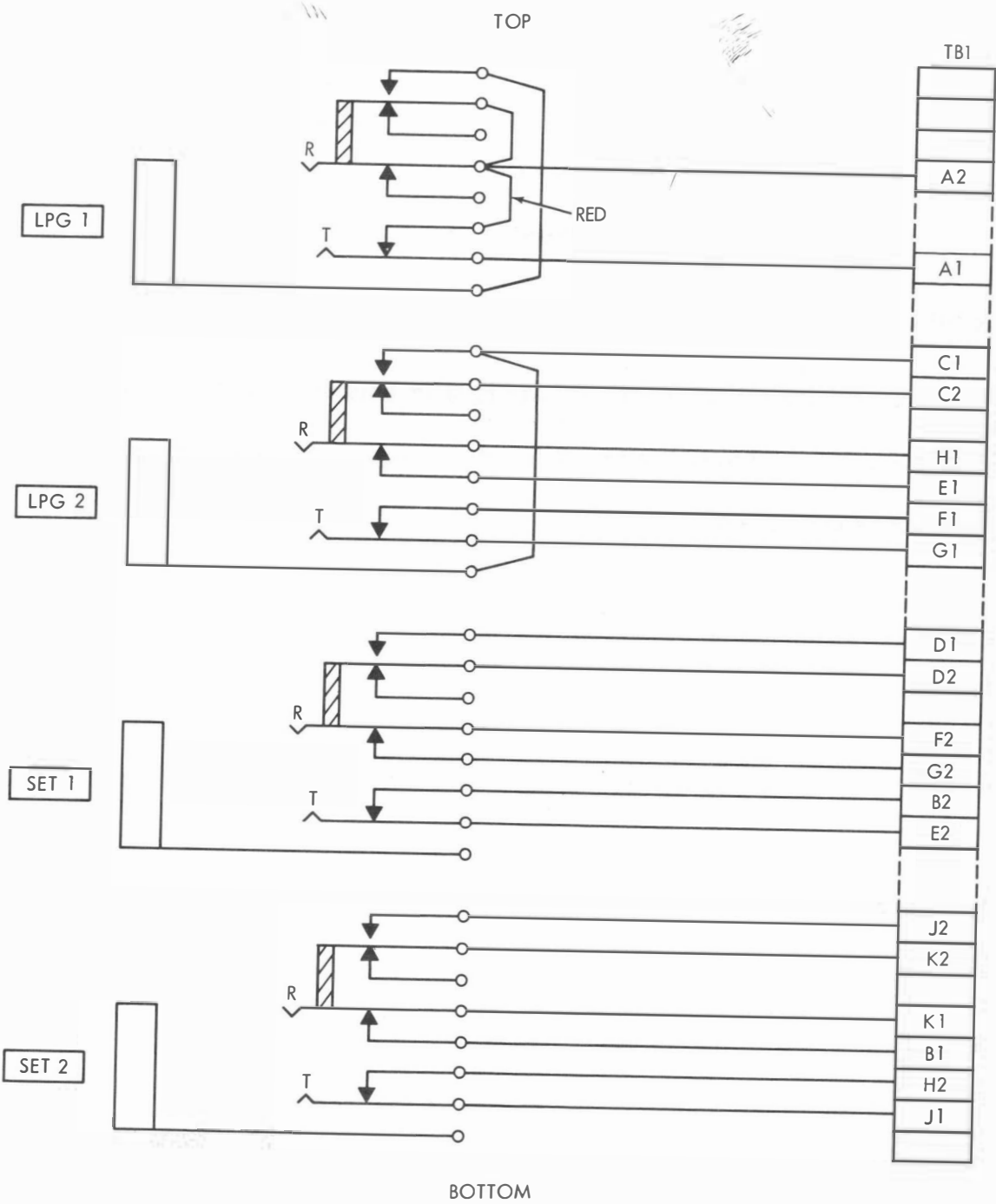

NOTES:

1. TYPICAL FOR JACK ROW 1. JACK ROW 2 THRU 26 ARE WIRED TO CONSECUTIVE TERMINAL BOARD ROWS.
2. INDICATES EQUIPMENT OPERATION MARKINGS (FRONT PANEL CONTROL).

Figure 6-1. Communication Patching Panel SB-3189A/FGC,
Schematic Diagram

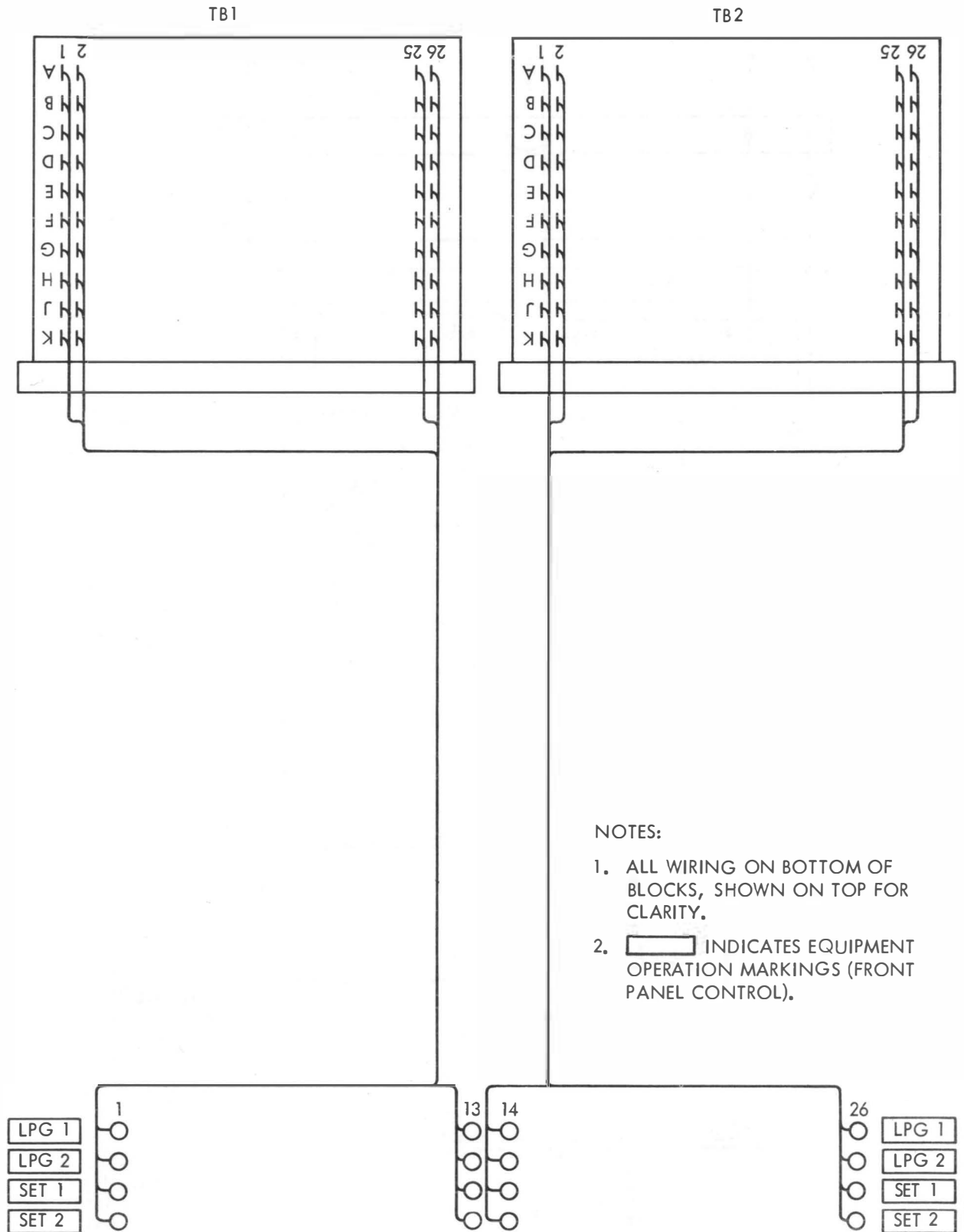

Figure 6-2. Communication Patching Panel SB-3189A/FGC,

Wiring Diagram

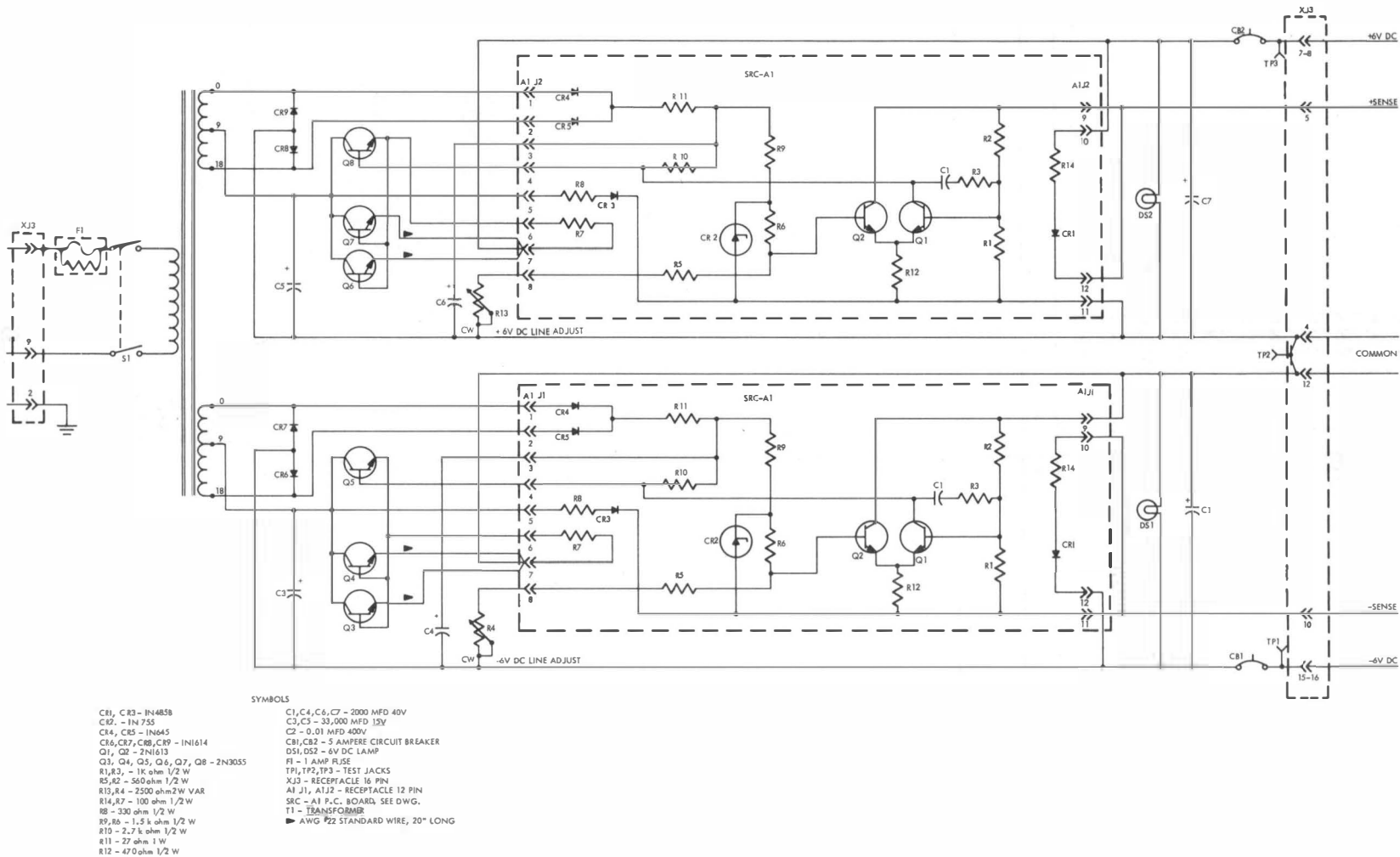

Figure 6-3. Power Supply PP-6521/FG,
Schematic Diagram

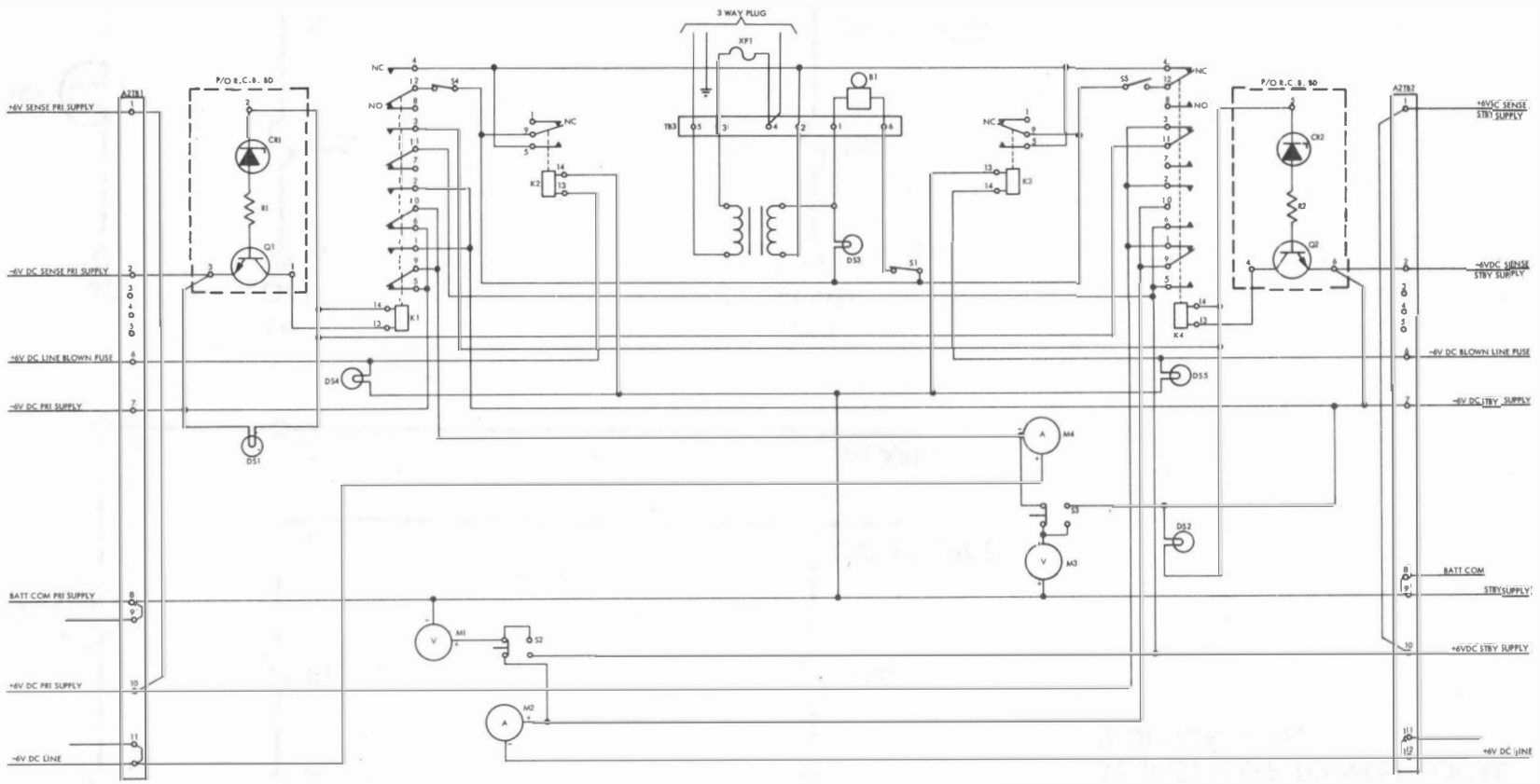
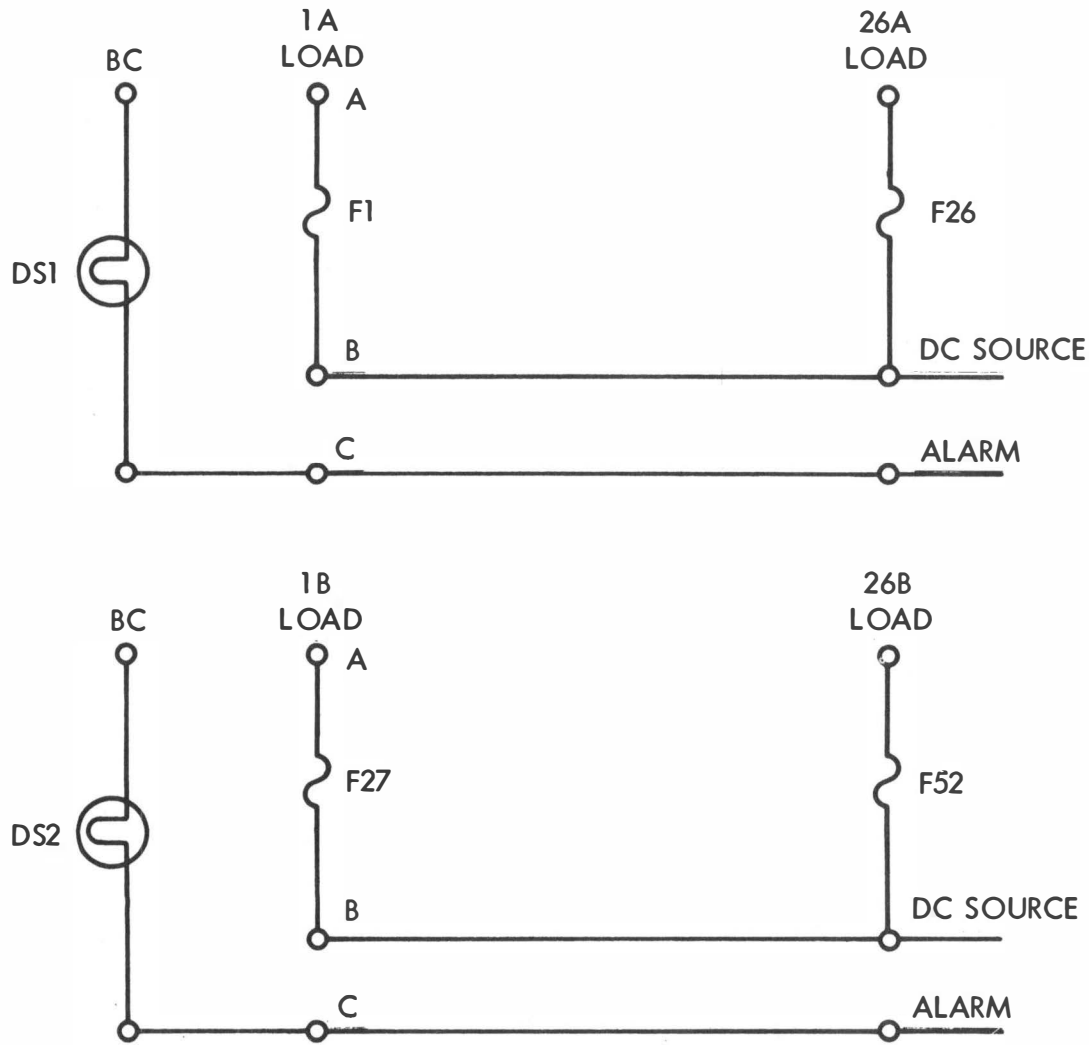

Figure 6-4. Control and Alarm Panel P/O

PP-6521/FG, Schematic Diagram



NOTE:
1. WIRING TO BE ACCOMPLISHED BY INSTALLER TO MEET LOCAL REQUIREMENTS.

Figure 6-5. Fuse Panel SB-3503/FG, Wiring Diagram (Typical)

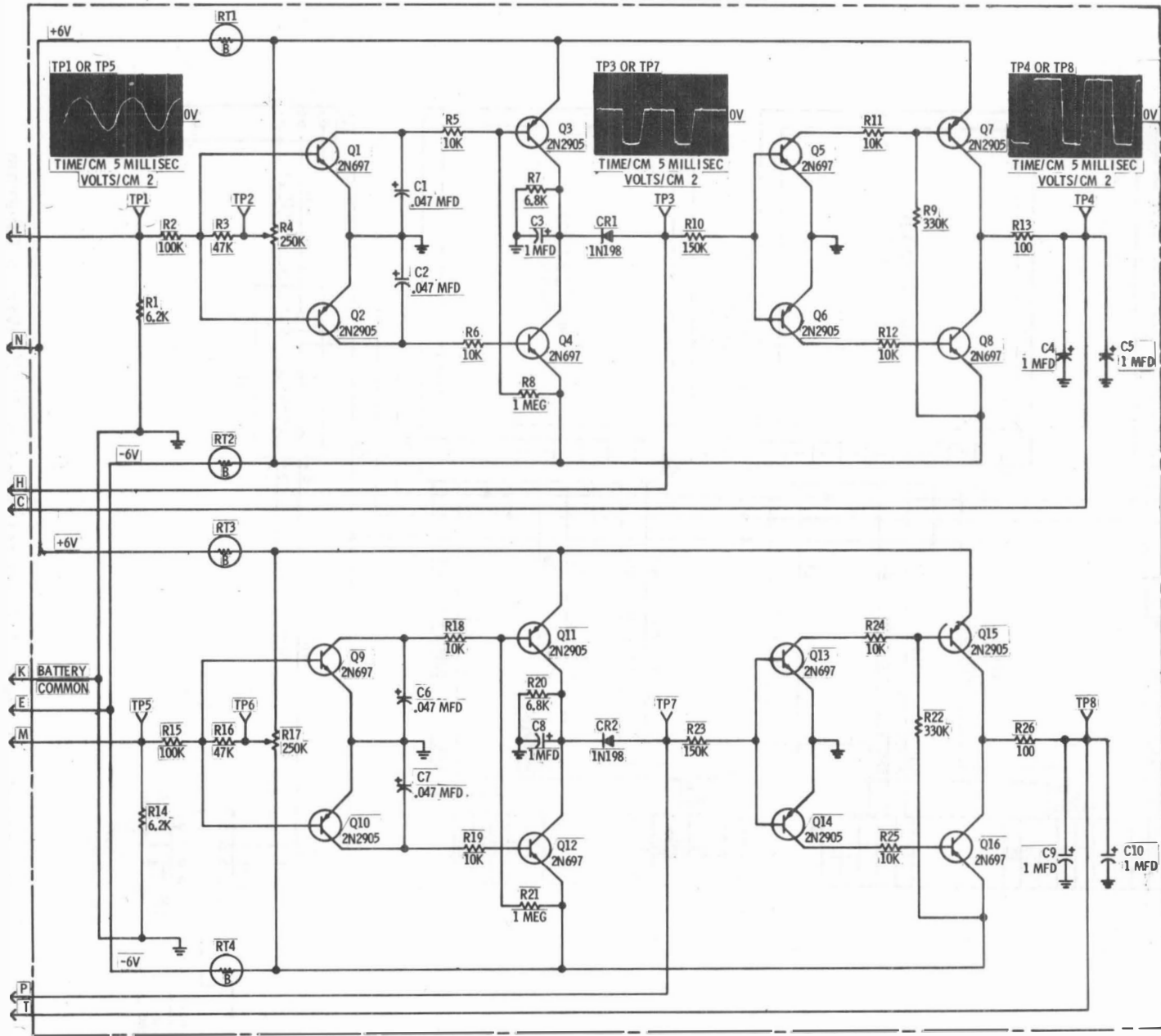

- NOTES:
1. UNLESS OTHERWISE INDICATED, ELECTRICAL VALUES FOR RESISTORS ARE EXPRESSED IN OHMS (K=1000 OHMS); RESISTOR - 1/4 WATT
 2. UNLESS OTHERWISE INDICATED, ALL VOLTAGES ARE DC TAKEN WITH A 20,000 OHM-PER-VOLT METER, AND MEASURED TO BATTERY COMMON
 3. WAVEFORMS SHOWN ARE TYPICAL FOR INPUTS FROM LOW-LEVEL MOD KITS MANUFACTURED BY TELETYPE CORP. OBSERVE THAT THE ILLUSTRATED OUTPUT SIGNAL HAS MARKING BIAS. THIS IS CAUSED BY MARKING BIAS ON THE INPUT SIGNAL. HENCE, THE NAME "REPEATER", TELEGRAPH.

Figure 6-6. Hubbing Repeater Card P/O

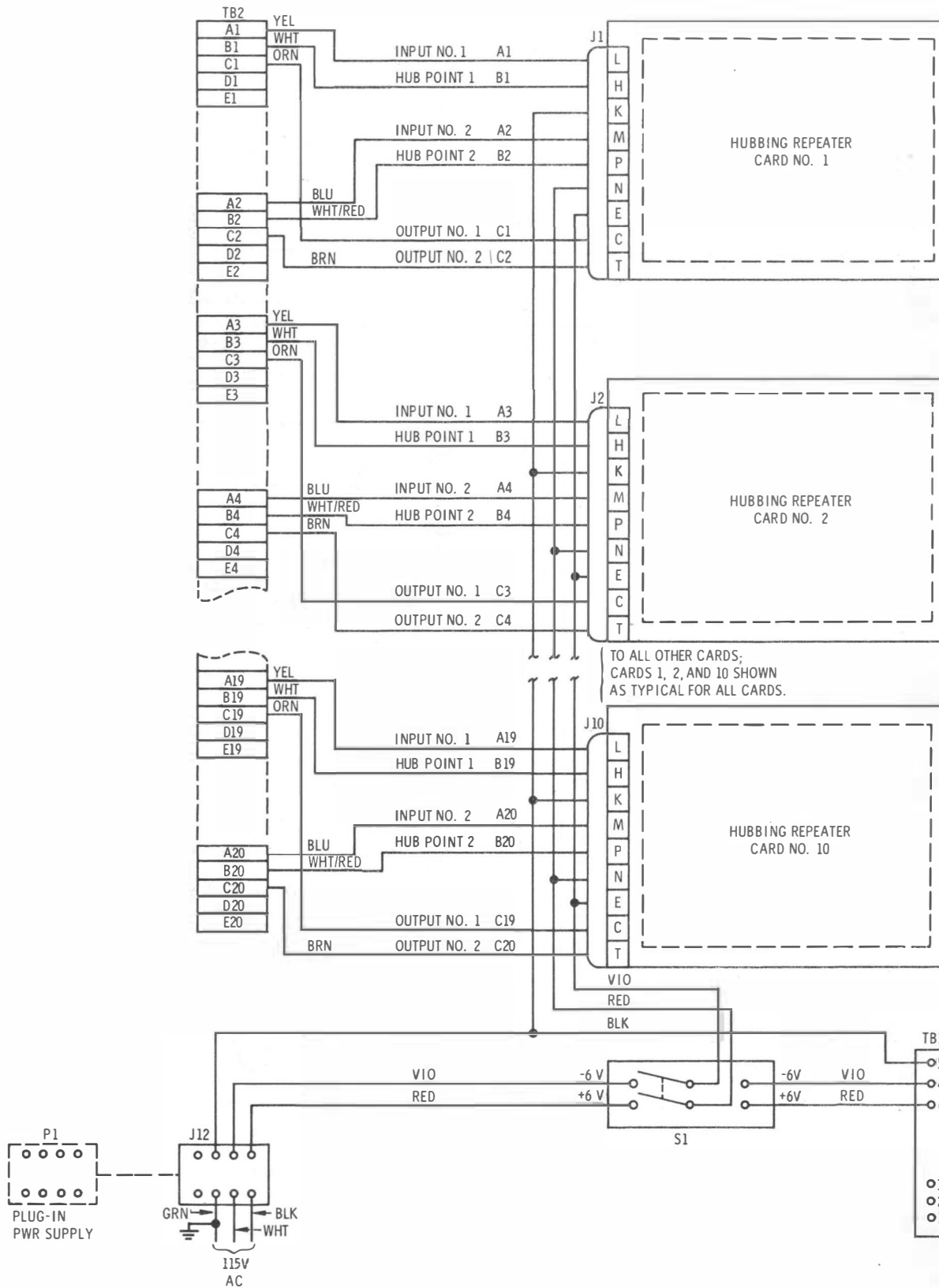

Figure 6-7. Telegraph Repeater TH-83A/FGC, Wiring Diagram.

N-1509

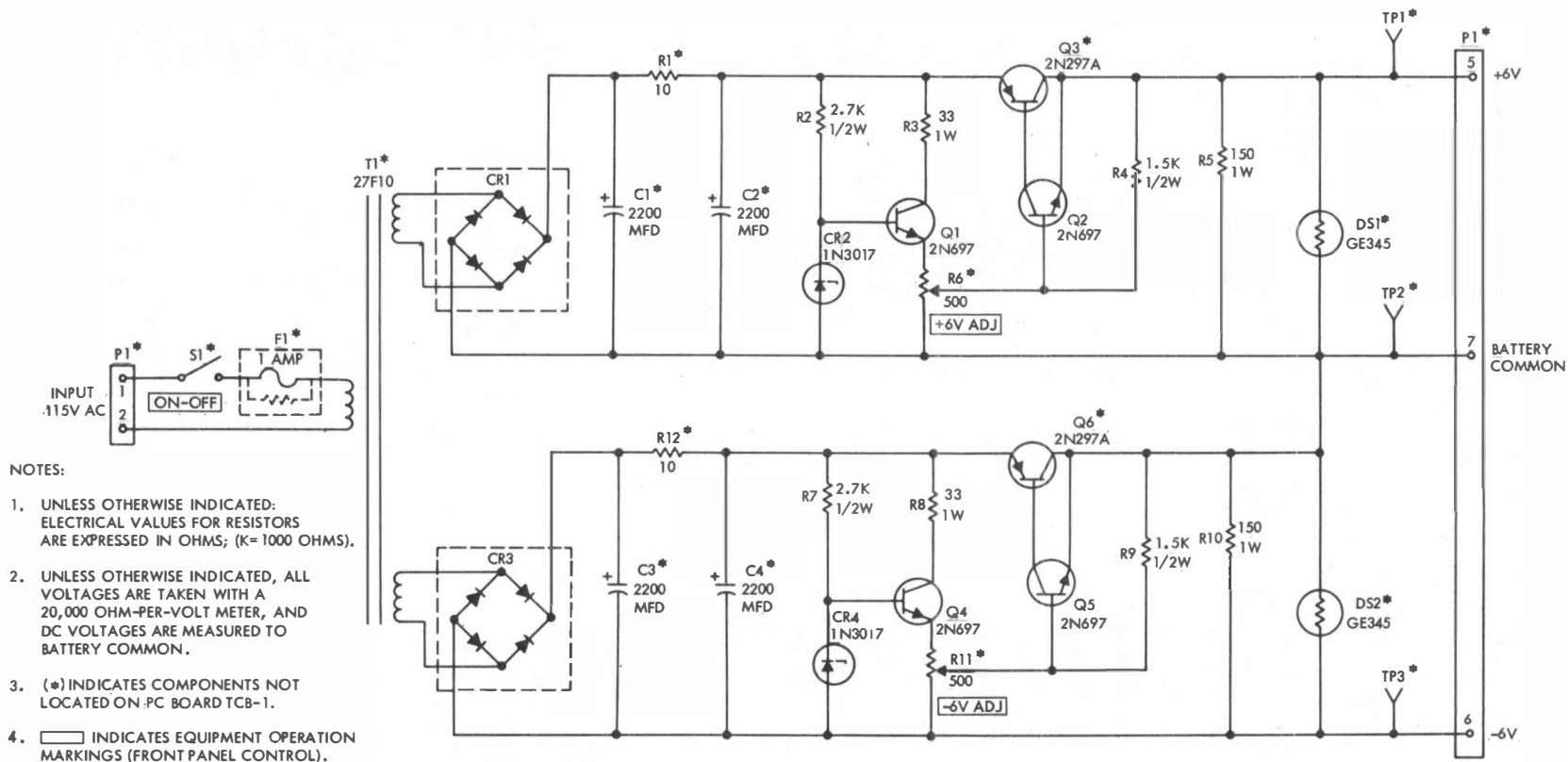
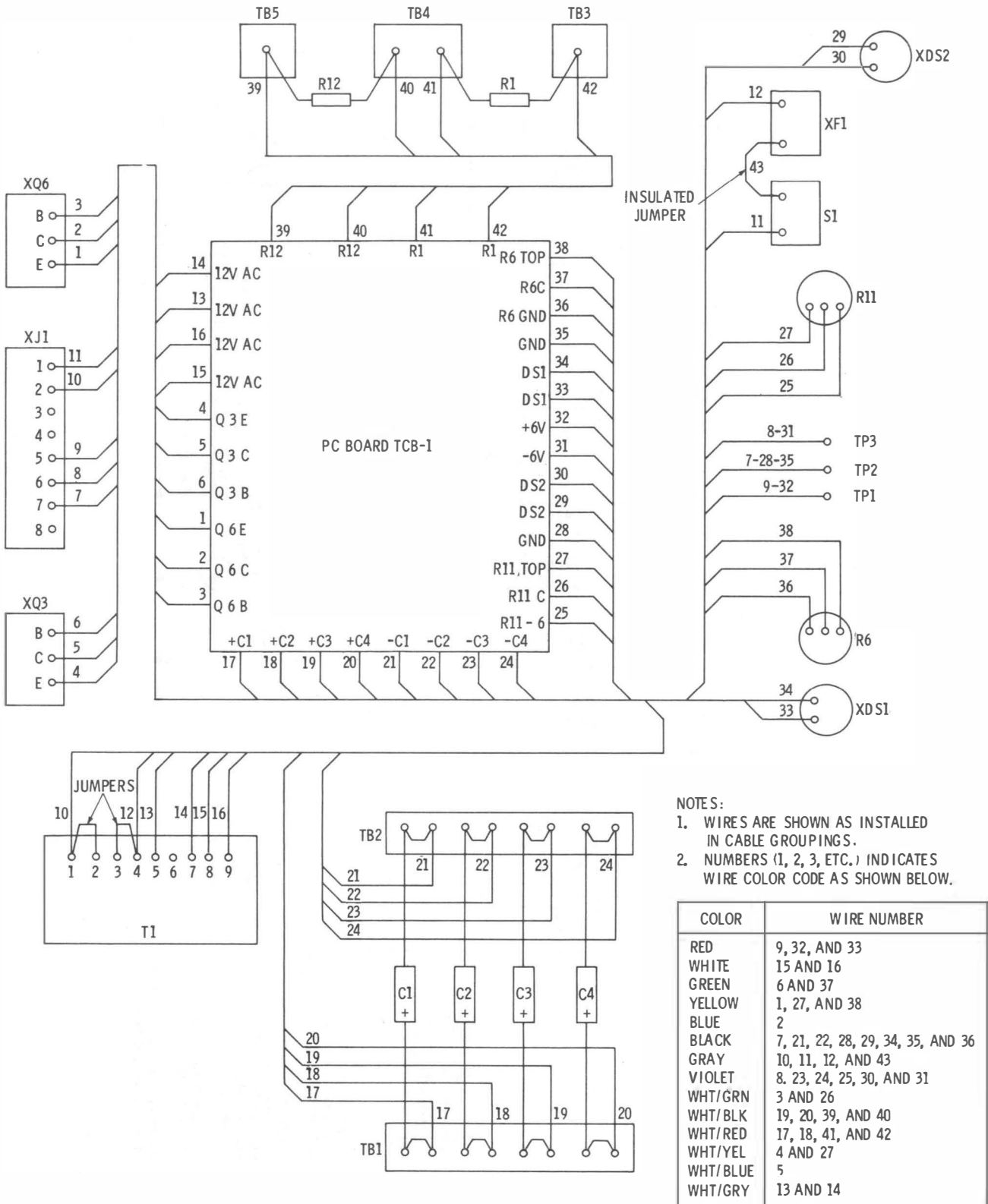

Figure 6-8. Power Supply P/O TH-83A/FGC, Schematic Diagram

Figure 6-9



- NOTES:
1. WIRES ARE SHOWN AS INSTALLED IN CABLE GROUPINGS.
 2. NUMBERS (1, 2, 3, ETC.) INDICATES WIRE COLOR CODE AS SHOWN BELOW.

COLOR	WIRE NUMBER
RED	9, 32, AND 33
WHITE	15 AND 16
GREEN	6 AND 37
YELLOW	1, 27, AND 38
BLUE	2
BLACK	7, 21, 22, 28, 29, 34, 35, AND 36
GRAY	10, 11, 12, AND 43
VIOLET	8, 23, 24, 25, 30, AND 31
WHT/GRN	3 AND 26
WHT/BLK	19, 20, 39, AND 40
WHT/RED	17, 18, 41, AND 42
WHT/YEL	4 AND 27
WHT/BLUE	5
WHT/GRY	13 AND 14

Figure 6-9. Power Supply P/O TH-83A/FGC, Wiring Diagram

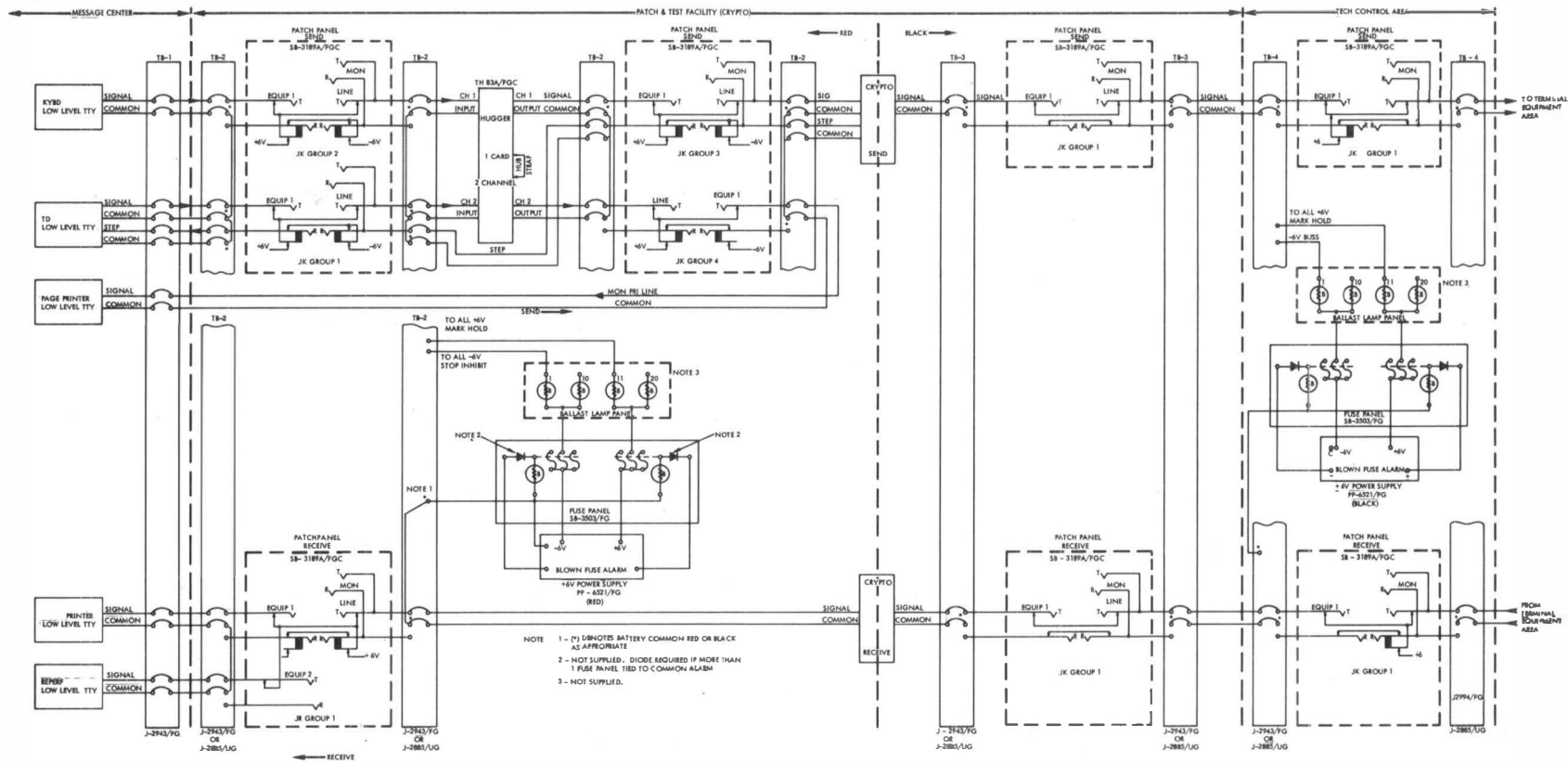

Figure 6-10. Typical Low-Level Technical Control Equipment, Line Drawing