

15 PERFORATOR
REQUIREMENTS AND ADJUSTMENTS

CONTENTS	PAGE	CONTENTS	PAGE
1. GENERAL	2	Counting-magnet armature eccentric (stop)	23
2. REQUIREMENTS AND ADJUSTMENTS	2	Counting-magnet check-latch- pawl bracket	23
All 15 Perforators		Dashpot	24
Armature-lever left stop	8	Dashpot-vent screw	26
Armature-lever right stop	8	Feed-pawl bracket	20
Back-space lever spring	5	Feed-pawl spring	25
Back-space pawl spring	5	Ratchet position and dashpot plunger spring	20
Feed-pawl adjusting bracket	16	Ratchet-return spring tension	22
Feed-pawl eccentric	16	Release-latch spring	24
Feed-pawl guide	16	Release-lever extension	23
Feed-pawl spring	16	Release-lever extension adjusting screw	23
Feed-punch selector lever	8	Release-magnet armature eccentric (stop)	22
Feed-roll	3	Signal-lamp contact cam	26
Feed-roll detent, final setting	18	Signal-lamp contacts	26
Feed-roll detent, preliminary setting	5	Signal-lamp contact springs	26
Feed-roll detent spring	6	Signal-lamp short contact-spring ..	26
Keylever springs	3		
Punch-contact bracket	9	Units Equipped with Positive- Action Perforating Mechanism	
Punch-contact operating-lever backstop screw	15	Antichatter lever	13
Punch-contact operating-lever return spring	16	Antichatter lever spring	15
Punch-magnet core	16	Contact points	15
Selector-bar-assembly bracket	2	Latch extension	14
Selector bar assembly	2	Positive-action latch spring	14
Selector-finger retainer	8	Punch-contact operating lever	13
Selector-lever bearing bracket	7	Punch contacts	12
Tape-guide spring	9	Contact points	12
Tape knife	18	Left contact spring	12
Tape-stripper plate	18	Punch-magnet control contact springs	12
Tape-tension lever	3	Punch-magnet control contacts	15
Tape-tension lever spring	4	Punch-operating contacts	12
Counter Mechanisms		Units Not Equipped with Positive- Action Perforating Mechanism	
Check-latch-pawl spring	24	Antichatter mechanism	11
Counter-control contact assembly ..	19	Key-pressure adjusting mechanism ..	10
Contact operating fiber extensions	20	Punch contacts	9
Contact spring No. 3	20	Punch-contact operating-lever adjustable link	11
Counter contact springs	19		
Counter-control contacts	20		
Counter-control contact operating cam levers	18		
Counter-control contact operating mechanism	18		

SECTION 572-201-700

1. GENERAL

1.01 This section contains the requirements and adjustments for the 15 perforator. This section and the section covering teletypewriter general requirements and adjustments provide the complete adjusting procedures for the maintenance of the 15 perforator.

1.02 The 15 perforator is a keyboard-operated device equipped with the mechanisms necessary for preparation of perforated tape. The perforating mechanism is actuated by an electromagnet. The speed of the keyboard is not restricted to a preset rate but is dependent upon the ability of the operator, thus enabling tape to be perforated at a faster rate than can normally be used for transmission.

1.03 The following requirements and adjusting procedures are arranged in a sequence that should be followed if a complete readjustment of the perforator is undertaken. If any adjustment is changed, related adjustments should be checked. After each portion of the adjustment is completed put back and tighten any screws, nuts, and parts that had to be removed to facilitate the adjustment.

1.04 Auxiliary Features: (1) The TP99037 Set of Parts provides easier backspacing and less abrupt tape feeding. The feed-pawl is not attached to the armature; (2) The TP102896 Set of Parts has a punch-contact latch to hold contact closed until armature has completely operated to provide positive action of the perforating mechanism with improved antichatter feature. It also has an adjustable universal bar link.

2. REQUIREMENTS AND ADJUSTMENTS

Note: Requirements 2.01 and 2.02 need be checked only when a new selector-bar assembly is being installed or when the number of selector-bar-assembly bracket shims has been changed. The adjustments for these requirements ordinarily should not be made on the customer's premises due to the extensive disassembly usually required.

2.01 Selector-bar Assembly: All keylevers should have some play between the upstop and the selector bars. Levers in line with the high portions of the front selector bar A-1 should clear the bar by not more than 0.030 inch when the bars are locked in position by the depression of either (1) the Q keylever, (2) the P keylever, or (3) the B keylever.

To Gauge: Hold the Q keylever fully depressed and check all other keylevers in turn by feel, gauging the clearance by eye while observing the vertical play of each keylever in its guide slot. Release the Q keylever, hold down the P keylever, and repeat the check. Finally, repeat it again with the B keylever held down.

To Adjust: Add or remove shims between the selector-bar-assembly bracket and the keyboard casting at the front corners. See Figure 1.

2.02 When the T keylever is fully depressed there should be some clearance, not more than 0.020 inch, between the rear selector bar (E-2) and the unoperated keylever which has the least clearance.

To Gauge:

(1) Lock the T keylever in its fully depressed position. This may be done with a wedge in a comb slot at the front of the keyboard. Care should be taken not to bend the comb.

(2) Turn the keyboard over so that the bottom is accessible.

(3) With a spring hook, hold the E-2 selector bar as far away from the keylevers as the slack in its supporting parts will permit.

(4) Check the clearances between the E-2 selector bar and the keylevers to find the lever with the minimum clearance. By gauge determine that this clearance is as called for above.

To Adjust: Add or remove shims between the selector-bar-assembly bracket and the keyboard casting at the rear corners.

Note: Excessive clearance may result in deep touch. Should the clearance be excessive only at some keylevers, check the selector bars at the leather upstops for wear. Replace them if necessary.

2.03 Selector-bar-assembly Bracket should be parallel to the rear keylever guide.

To Adjust: Remove the left and right keyboard slide plates, loosen the selector-bar-assembly mounting screws, and position the assembly. Put back the keyboard slide plates. See Figure 1.

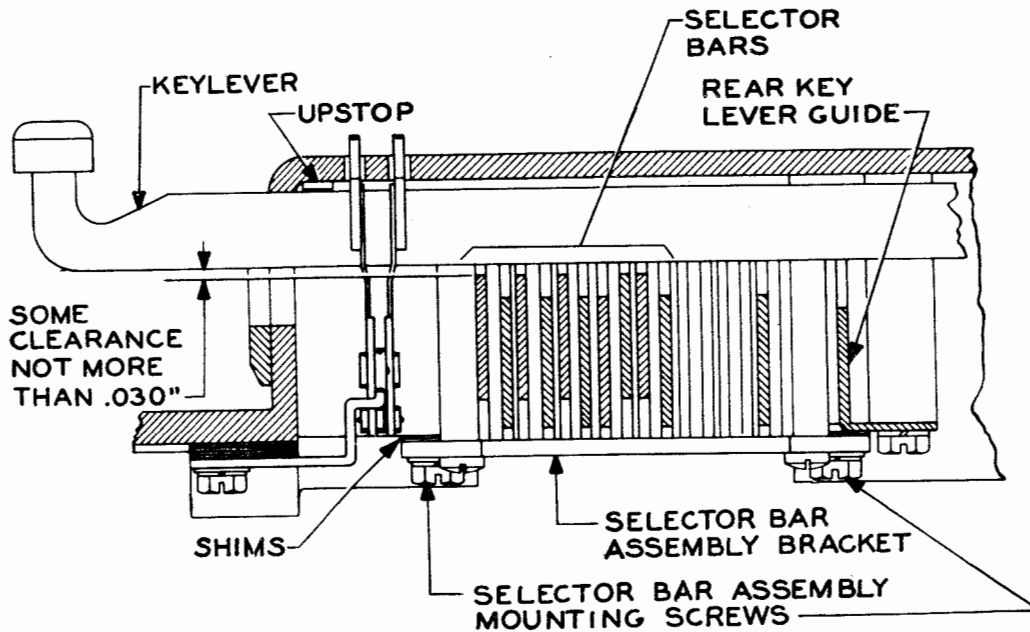

Figure 1

2.04 Keylever Springs: The opening of the keylever springs when removed from the keyboard should be:

<u>Keylever Springs</u>	<u>Spring Opening</u> (X in Figure 2)
All Characters and BLANK	1-3/16 inch
CR, LF, LTRS and FIGS	1-9/16 inch
Space (3-inch Space Bar)	1-3/4 inch
Space (8-1/2-inch Space Bar) (centrally located keylever)	1-5/8 inch

To Adjust: Bend the spring. See Figure 2.

2.05 Feed-roll should rotate freely and have endplay as specified in the figure when its detent, feed-pawl, and tape-tension lever are held clear of the feed roll.

To Adjust: Position the rear bracket, using shims between the bracket and the punch casting. See Figure 3.

2.06 Tape-tension Lever should be centrally located with respect to the feed-roll pins.

To Gauge:

(a) Take up the feed-roll endplay towards the star wheel and the tension-lever endplay towards its adjusting nut. The edge of the lever slot may touch the feed-roll pins on the side of the pins nearest the star wheel but there must be clearance on the other side.

(b) Take up the feed-roll endplay away from the star wheel and the tension-lever

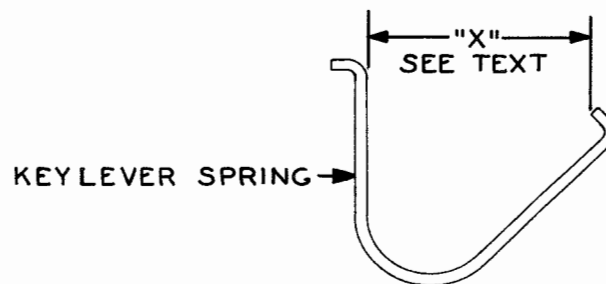

Figure 2

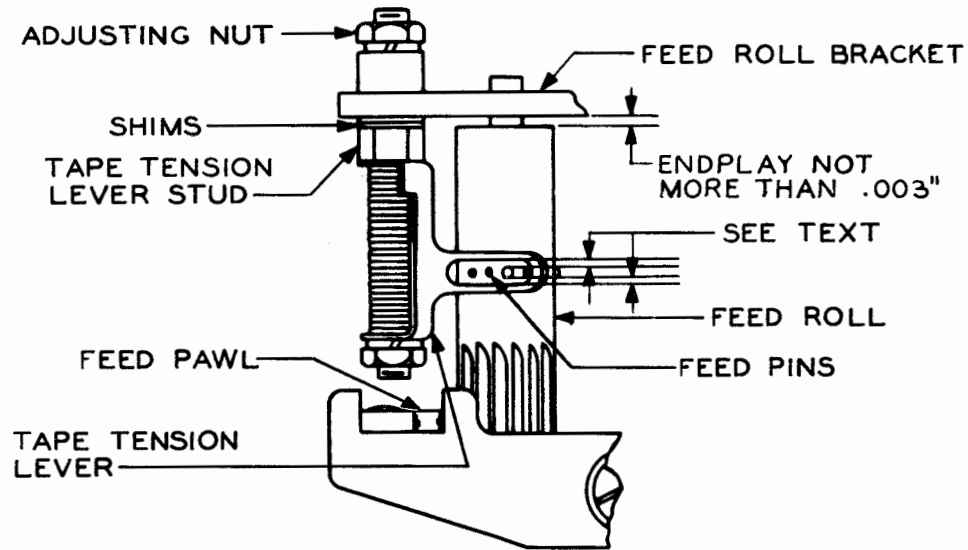

Figure 3

endplay away from the tension adjusting nut. The edge of the lever slot may touch the feed-roll pins on the side farthest away from the star wheel but there must be clearance on the other side.

To Adjust: Add or remove shims between the shoulder on the tape-tension-lever stud and its mounting bracket. See Figures 3 and 6.

2.07 Tape-tension Lever Spring: It should require a pull as specified below to start the

slotted extension of the lever moving away from the feed roll.

Spring	Turns	Pull	
		Min	Max
TP110974 (new style)	15	14 oz	16 oz
TP84023 (old style)	18	5 oz	5-1/2 oz

To Gauge: Hook a scale over the end of the tape-tension lever. Pull the lever with the scale held perpendicular to the lever.

To Adjust: Loosen the tape-tension lever stud locknut and rotate the stud to obtain the required tension. See Figure 4.

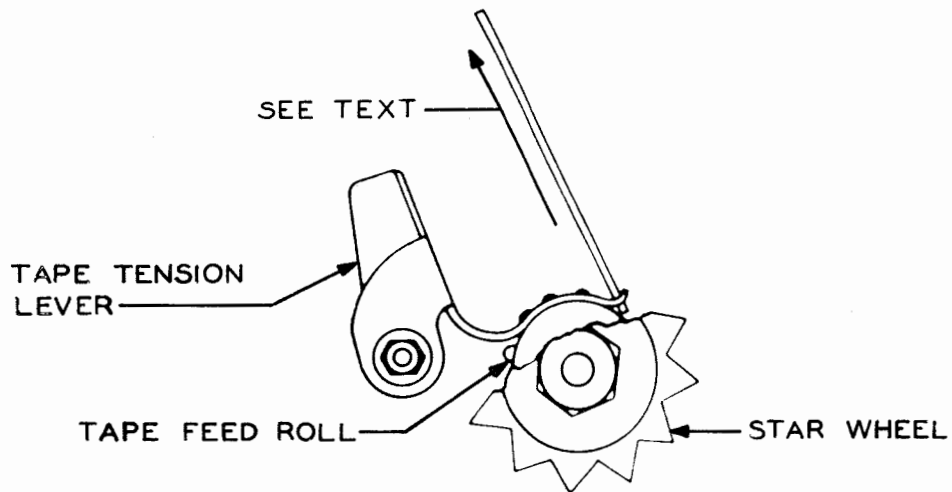

Figure 4

2.08 Back-space Lever Spring: It should require a push as specified in the figure to start the back-space lever moving downward. See Figure 5.

2.09 Back-space Pawl Spring: It should require a pull as specified in the figure to start the back-space pawl moving upward. See Figure 5.

Note: To facilitate adjustments of units with the counter mounted at the left of the keyboard, remove the counter mechanism.

2.10 Feed-roll Detent, Preliminary Setting: With the detent-lever roller resting between two teeth of the star wheel and the armature lever held in the operated position, insert the feed-roll positioning gauge TP73517 in the punch-block guide slot so that the projection of the gauge is against the feed-hole punch. Under these conditions a pin on the feed roll should line up with the center hole of the gauge.

To Adjust: Loosen the detent-eccentric-bushing mounting screw and position the bushing, keeping the center of the eccentric bushing below the center of the mounting screw. See Figure 6.

CAUTION: TO AVOID DAMAGING THE TP73517 GAUGE BY ACCIDENTAL OPERATION OF THE PUNCH PINS, HOLD THE ARMATURE OPERATED BY WEDGING A KS-6320 ORANGE STICK BETWEEN THE ARMATURE AND THE LEFT-STOP ADJUSTING SCREW BEFORE INSERTING THE GAUGE.

(a) If adjustment above cannot readily be obtained with the greater portion of the eccentric below its mounting screw, turn it until the greater portion is above its mounting screw to make this adjustment.

(b) On units equipped with the TP99037 Set of Parts, the adjustment under 2.10 must be made with the greater portion of the eccentric below its mounting-screw if there is interference between the locknut on the post supporting the back-space lever spring and the feed-roll detent lever.

Note: Interference is likely to occur only when a corner of the nut is downward in its tightened position.

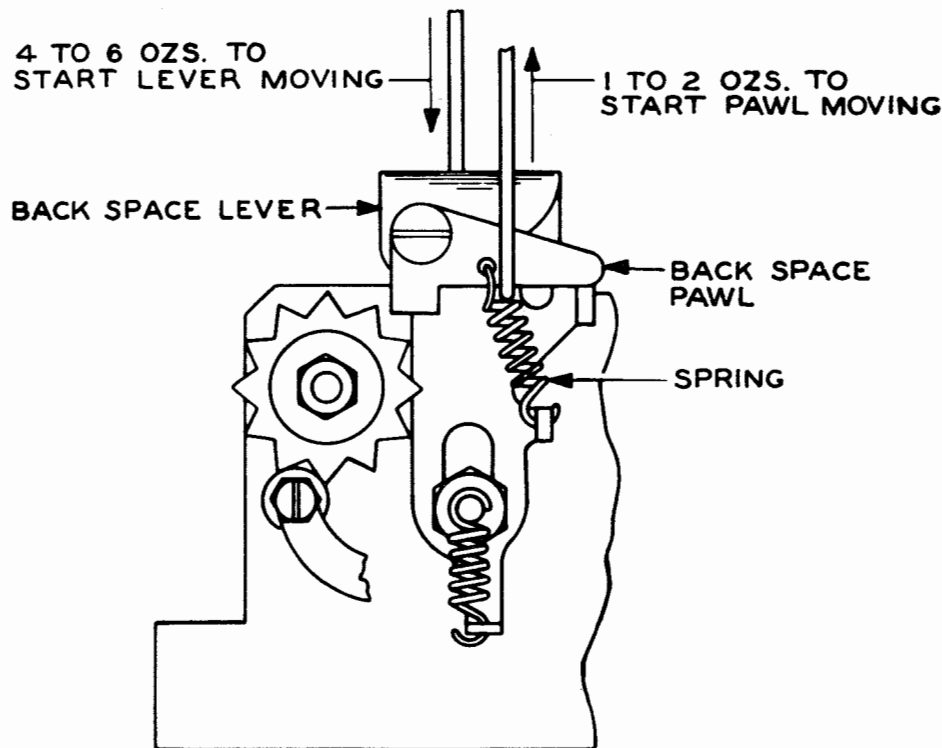

Figure 5

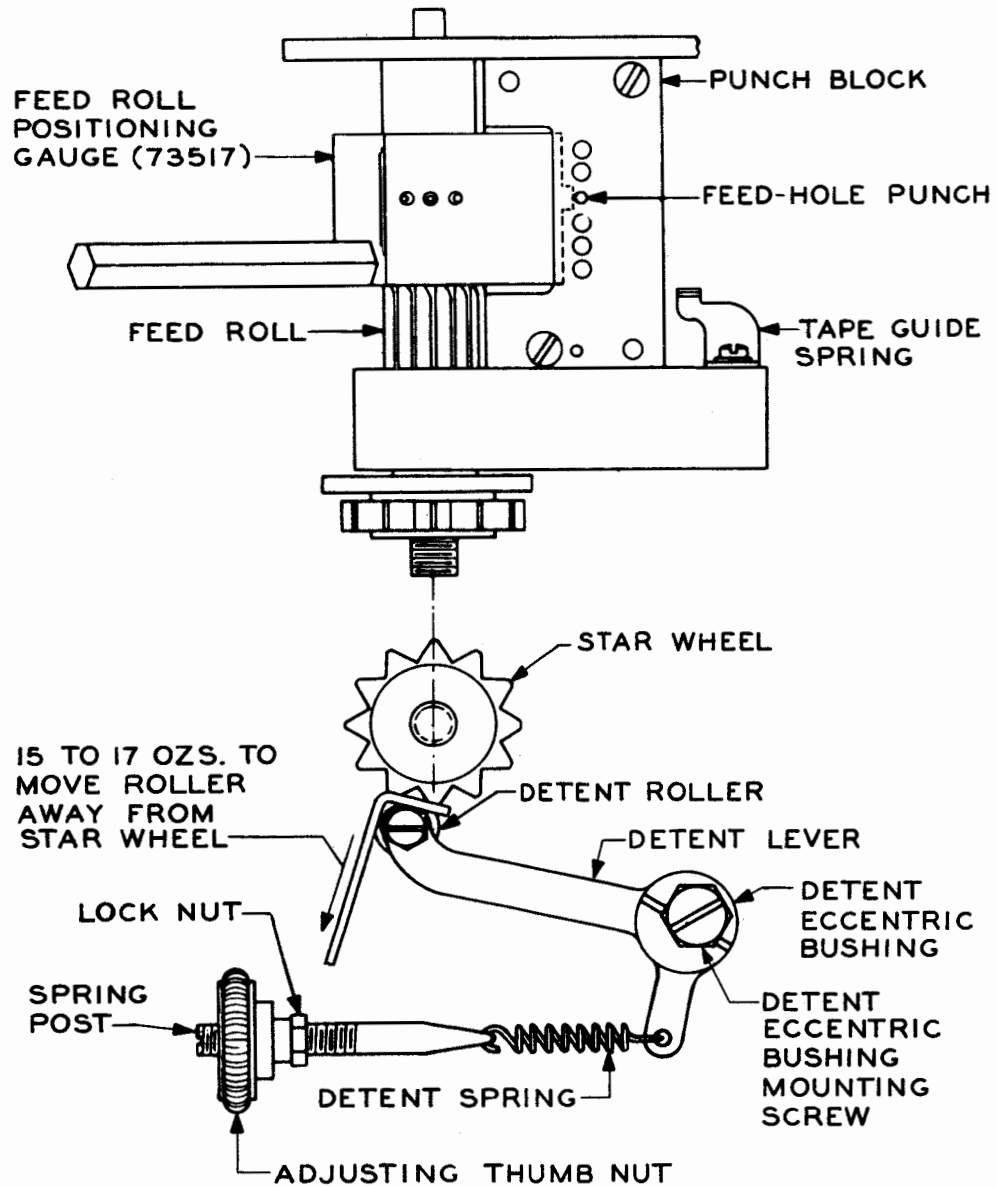

Figure 6

2.11 Feed-roll Detent Spring

(1) For units equipped with the TP99037 Set of Parts, it should require a pull as called for in the figure to start the roller moving away from the star wheel. See Figure 6.

To Adjust: Hold the adjusting thumbnut and loosen the locknut. Turn the thumbnut to obtain the proper tension. Hold the thumbnut when tightening the locknut.

(2) For units not equipped with the TP99037 Set of Parts, the detent spring should

have a pull of minimum 3 pounds, maximum 4 pounds when the detent roller starts moving away from the star wheel.

To Gauge: Apply a scale on the short end of the detent lever just above the spring hook. Pull in line with the spring and in the opposite direction. Replace the spring if necessary.

Note: Remove the tape-stripper plate and the tape knife to facilitate making or checking adjustments 2.12 through 2.40

2.12 Selector-lever Bearing Bracket: The tips of all the movable feed-punch selector fingers should be under the punches by not more than half the diameter of the punches (gauge by eye) when the selector bars are moved to a neutral position by simultaneously depressing the LTRS, LF, and BLANK or the R, T, and Y keylevers equally until stopped by the codebars.

To Check: Hold the three keylevers depressed and take up the play of the selector levers in a direction to make the engagement with the punches a maximum.

To Adjust: Loosen the selector-lever bearing bracket mounting screws and reposition the bracket. See Figure 7.

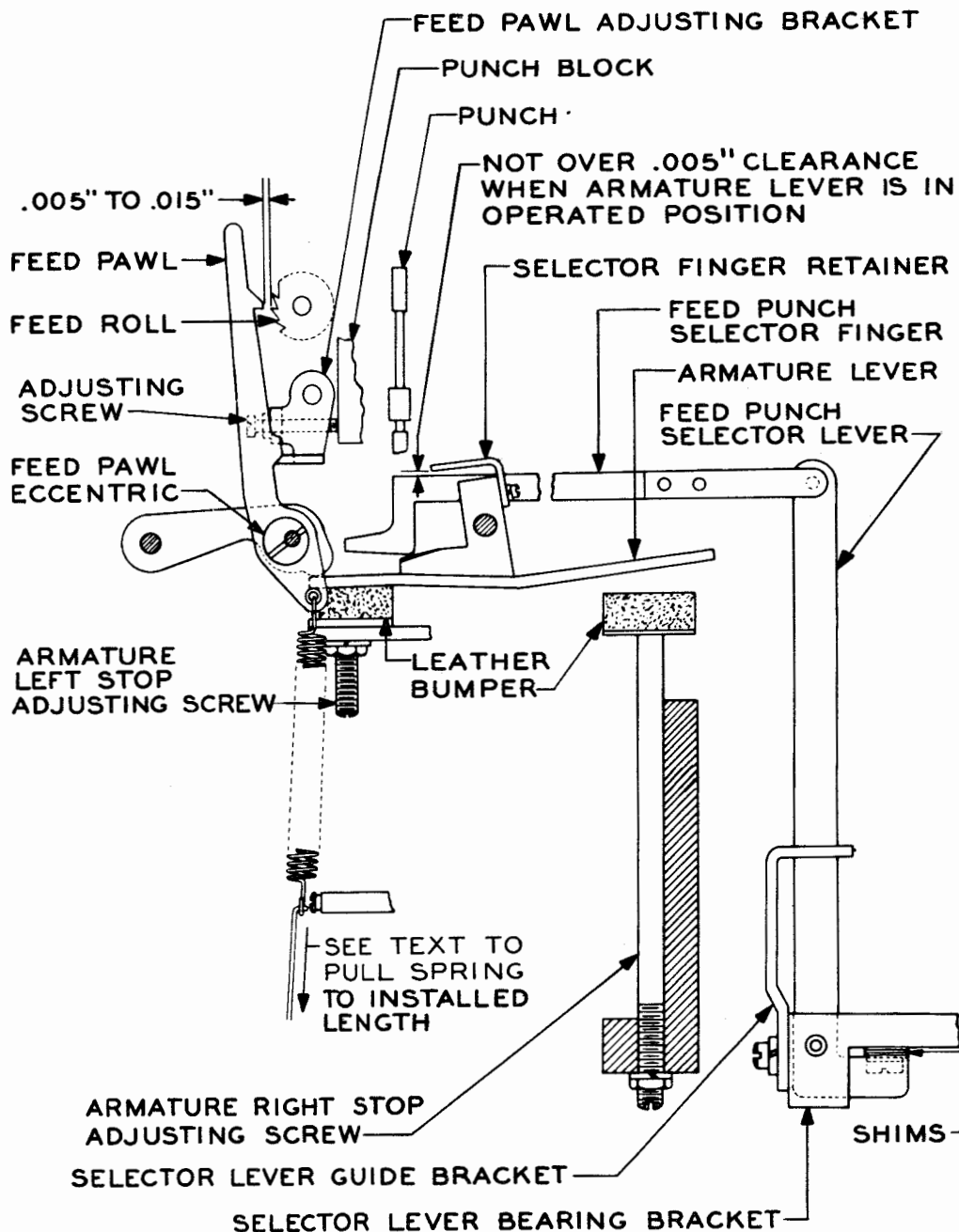

Figure 7

2.13 Feed-punch Selector Lever: The left end of the uppermost section of the feed-punch selector finger and the left-edge of the feed punch should line up. Gauge by eye.

To Adjust: Add or remove shims between the formed-over ear on the bottom of the selector lever and the selector-lever bearing bracket. See Figures 7 and 8.

2.14 Armature-lever Left Stop:

(1) For units equipped with TP99037 Set of Parts, The armature-lever left-stop should be so positioned that the feed-punch selector finger clears the feed punch by minimum 0.025 inch, maximum 0.030 inch when the left-end of the uppermost section of the finger lines up with the left-edge of the punch and when the armature lever is against its left-stop.

To Adjust: Position the left-stop adjusting screw and recheck after tightening the locknut. See Figures 7 and 8.

(2) For units not equipped with TP99037 Set of Parts, the armature-lever left-stop should be so positioned that each code-punch selector finger clears its associated punch pin by minimum 0.020 inch, maximum 0.025 inch, when the left ends of the uppermost section of the fingers line up with the left-edges of the punches, and when the armature lever is against its left-stop.

To Adjust: Position the left-stop adjusting screw and recheck after tightening the locknut. See Figure 7.

Note: Connect the perforator to a 115-volt dc source.

2.15 Armature-lever Right Stop:

Note: This adjustment must be made as outlined below in order to check the armature-lever right stop. Position the top left edge of each punch selector finger immediately below the left edge of its associated punch. Adjust the armature-lever right-stop adjusting screw until the punches just fail to perforate the tape when the punch contacts are closed. Withdraw the right-stop screw until all the punches just perforate the tape when the punch contacts are closed. The punches should completely perforate the tape when the selector fingers are positioned to the extreme left. Withdraw the right-stop screw more if necessary. To obtain margin, retract the right-stop screw an additional quarter turn after the preceding requirements are met. There should be some clearance between the armature and the magnet-core face when the armature lever is held firmly against its right-stop screw. Tighten the locknut. See Figures 7 and 8.

2.16 Selector-finger Retainer: There should be clearance as specified in the figure between the selector-finger retainer and the top

.025" TO .030"
WITH MAGNET IN AN
UNOPERATED POSITION

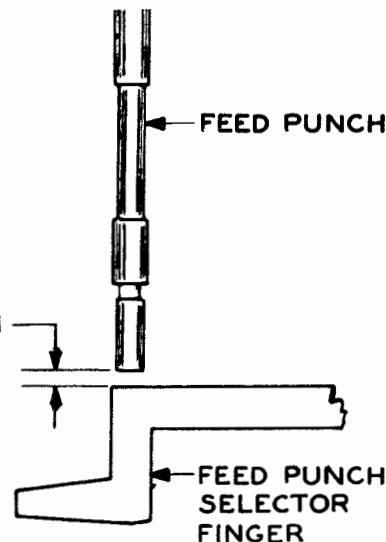

Figure 8

of the feed-punch selector finger when the armature lever is held in its operated position by the magnet. This same clearance should exist between the retainer and each of the selector fingers when the ends are in line. The retainer should be equidistant, within 0.005 inch from the No. 1 and the No. 5 selector fingers when the ends of all the selector fingers are in line. See Figure 7.

To Adjust: Position the retainer.

Note: Disconnect the perforator from the 115-volt dc source.

2.17 Tape-guide Spring:

- (1) The edge of the spring should be parallel to the edge of the casting on which it is mounted.

To Adjust: Position the spring. See Figure 6.

- (2) The spring should hold the tape securely against the side of the guide in the die block, adjacent to the No. 1 punch, without buckling the tape.

To Gauge: Take up the play of the tape in the die block toward the spring. Observe whether or not the spring returns the tape to the far side when the tape is released.

To Adjust: Bend the spring. See Figure 6.

2.18 Punch-contact Bracket: The punch-contact bracket should be positioned so that its mounting screws are in the center of the elongated holes in the bracket.

To Gauge: Remove one mounting screw at a time in order to determine whether or not the bracket is placed properly.

To Adjust: Position the bracket.

Note: Before making adjustments (2.19 through 2.33 inclusive) backoff the punch-contact operating lever back-stop screw. Adjustments 2.19 through 2.22 inclusive apply to units not equipped with positive-action perforating mechanism.

2.19 Punch Contacts:

- (1) It should require a pull as specified in the figure to separate the insulator from the antichatter lever. See Figure 9.

Gauge with the antichatter lever resting against its adjusting screw, the armature lever against its left stop, and the right punch-contact point held away from the left punch-contact point by the contact-operating lever.

To Adjust: Bend the left punch-contact spring.

- (2) It should require a pull as specified in the figure to separate the contact points with any keylever depressed. See Figure 10.

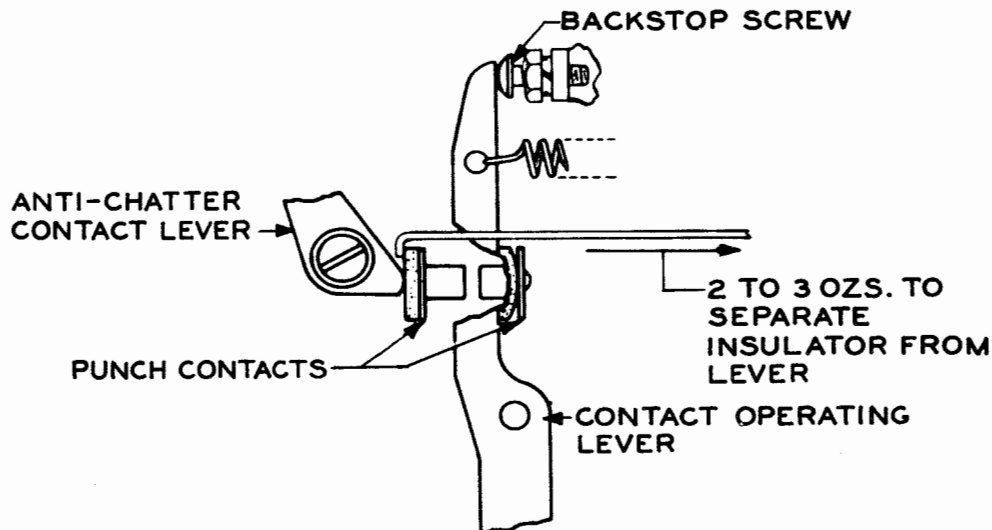

Figure 9

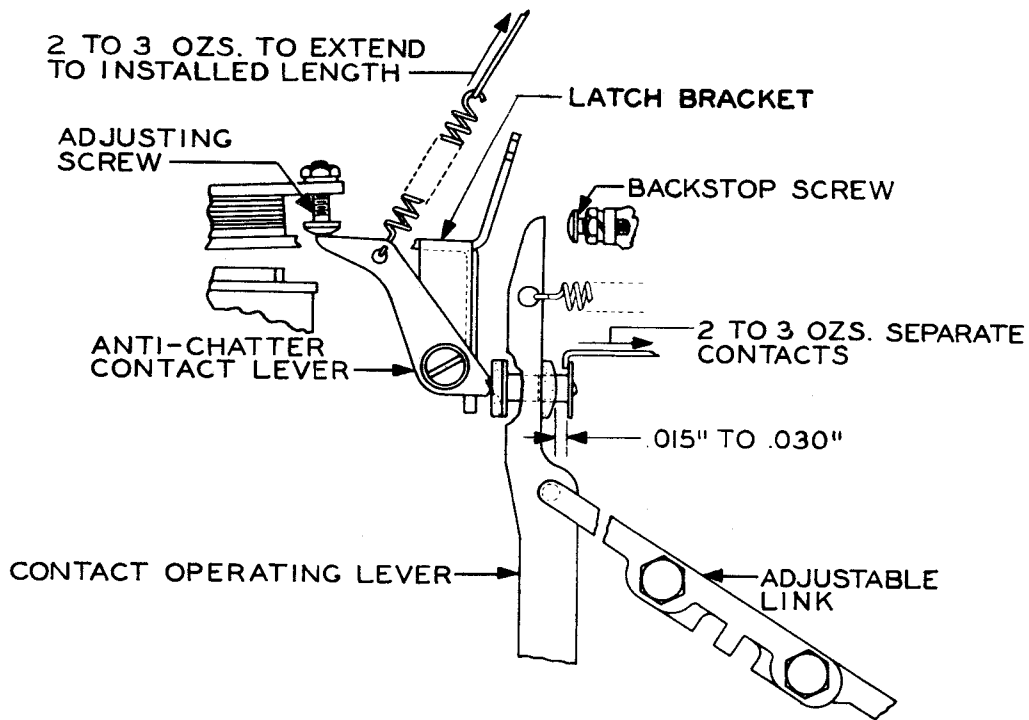

Figure 10

To Gauge: Hook a scale over the right contact spring at the contact point.

To Adjust: Bend the right punch-contact spring.

The punch-contact operating-lever backstop screw should line up with the contact operating lever.

2.20 Key-pressure Adjusting Mechanism: The contact-operating-lever return-spring adjusting mechanism should be free from binds over the entire range of the adjusting screw.

To Adjust the punch-contact operating-lever backstop screw, loosen the mounting screws, position the key-pressure adjusting mechanism, and tighten the mounting screws. See Figure 11.

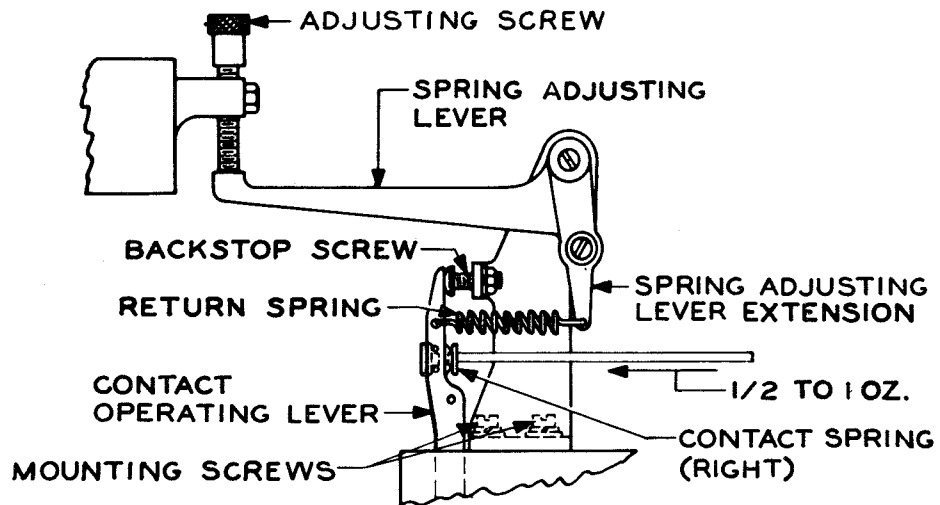

Figure 11

Note: Raising or lowering the adjusting screw will vary the tension exerted by the return spring on the contact-operating lever, and consequently the pressure required to operate the lever through the keyboard.

2.21 Antichatter Mechanism

- (1) The edge of the topmost portion of the antichatter contact lever should be approximately horizontal.

Gauge with the armature lever resting firmly against its left stop and the antichatter lever in contact with the adjusting screw in the armature.

To Adjust: Position the adjusting screw. See Figure 10.

- (2) There should be at least 0.005 inch clearance between the antichatter contact lever and the adjusting screw.

Gauge with the armature lever resting firmly against its right stop and the antichatter lever held manually against the magnet spool head.

To Adjust: Position the adjusting screw and recheck (1). See Figure 12.

- (3) The end of the antichatter contact lever should extend at least 1/32 inch to the left of the center of the adjusting screw.

Gauge with the armature lever resting firmly against its left stop.

To Adjust: Position the latch bracket for the antichatter contact lever and recheck (1) and (2). See Figure 10.

- (4) It should require a spring tension as specified in the figure to stretch the antichatter contact lever spring to its installed length. See Figure 10.

To Gauge: Unhook the spring from the bracket and hook a scale in the spring eye.

2.22 Punch-contact Operating-lever Adjustable Link:

There should be a clearance as specified in the figure between the right contact spring and the insulator on the contact operating lever. See Figure 10.

To Gauge: Determine the keylever (including the SPACE keylever) which moves the punch-magnet contact-operating lever the least amount when fully depressed. With this keylever fully depressed check the requirement.

To Adjust: Loosen the two screws which clamp the adjustable link together and shorten or lengthen the link.

Note: With the foregoing adjustment, the punch contacts will not close until the keylevers nearly reach the bottom of their travel. It is permissible to adjust the link so that the punch contacts will close on a shorter keylever stroke provided all punch selector fingers engage their associated punches by the full diameter of the pin at the

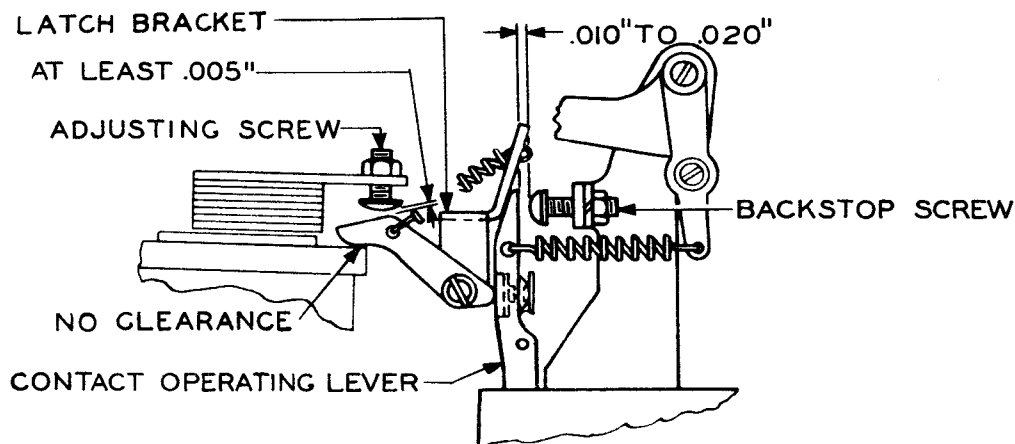

Figure 12

time the punch contacts close. To check this adjustment, position all the punch selector fingers to the right and then depress the LTRS keylever slowly until the punch contacts close. Connect a lamp across the contacts to determine when they close. To adjust for a shorter keylever stroke, lengthen the punch-contact operating-lever link.

THE FOLLOWING ADJUSTMENTS APPLY TO UNITS EQUIPPED WITH THE POSITIVE-ACTION PERFORATING MECHANISM (2.23 THROUGH 2.33 INCLUSIVE).

2.23 Punch-magnet Control Contact Springs should be straight without sharp bends and the contact points should meet squarely in line. The left (short) contact-spring stiffener should extend approximately parallel with the face of the contact bracket. Gauge by eye.

To Adjust: Bend the stiffener.

2.24 Left Contact Spring: It should require a pull as specified in the figure to just start the left contact spring moving away from its stiffener when the antichatter lever is held away from the insulator on the left contact spring. See Figure 13.

To Gauge: Hook a scale over the left contact spring just to the rear of the contact point and pull at right angles to the contact spring.

To Adjust: Bend the left contact spring.

2.25 Contact Points: With any keylever depressed it should require a tension as specified in the figure to just separate the contact points when there is some clearance between the antichatter lever and the insulator on the (short) left contact spring, and clearance between the insulator on the punch-operating lever and the right contact spring. See Figure 14.

To Adjust: Bend the right contact spring.

2.26 Punch Operating Contacts: There should be clearance as specified in the figure when there is some clearance between the antichatter lever and the insulator on the left (short) punch-operating contact spring, and the punch-contact-operating lever is held in its latched position by the positive action latch. See Figure 13.

To Adjust: Position the latch by moving its bracket under its mounting-screws.

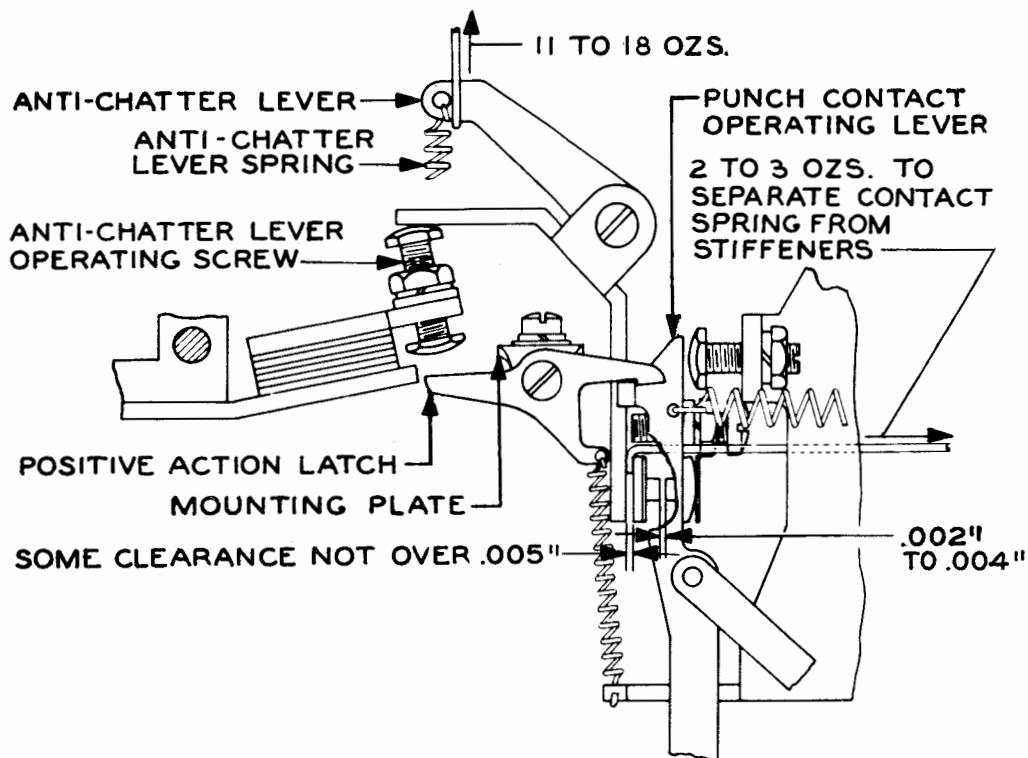

Figure 13

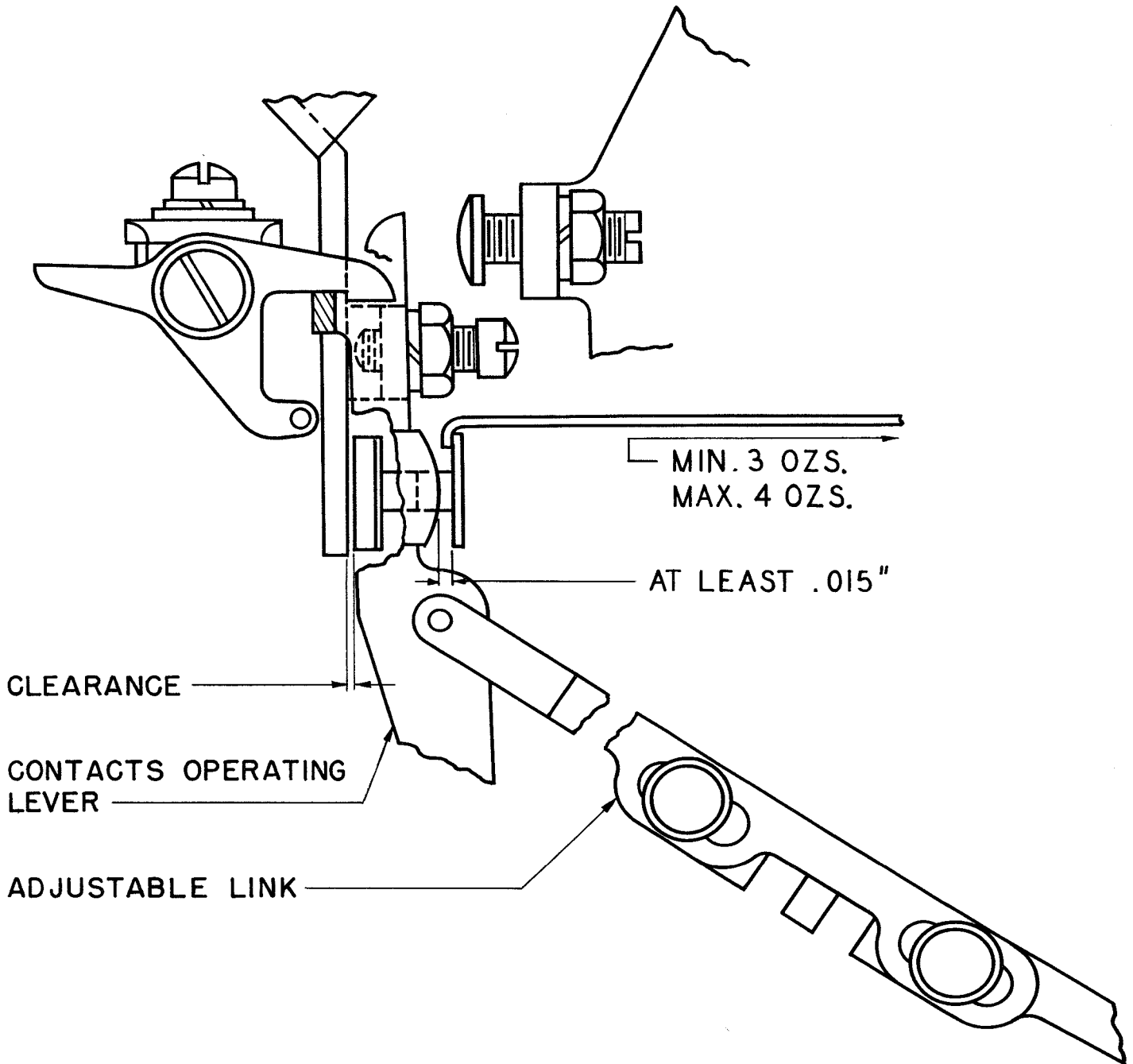

Figure 14

2.27 Antichatter Lever: There should be clearance as specified in the figure between the antichatter lever and the insulator on the left (short) contact spring when the punch-magnet armature lever is resting firmly against its left (unoperated) stop and the antichatter lever is resting firmly on its operating screw in the armature. See Figure 13.

To Adjust: Position screw in the armature.

2.28 Punch-contact Operating Lever: There should be clearance as specified in the figure between the insulator on the punch-contact operating lever and the right (long) contact spring when the antichatter lever is resting firmly against its backstop screw and the punch-contact operating lever is held in its latched position by the positive action latch, and the armature is lifted off its left stop approximately 1/16 inch. See Figure 15.

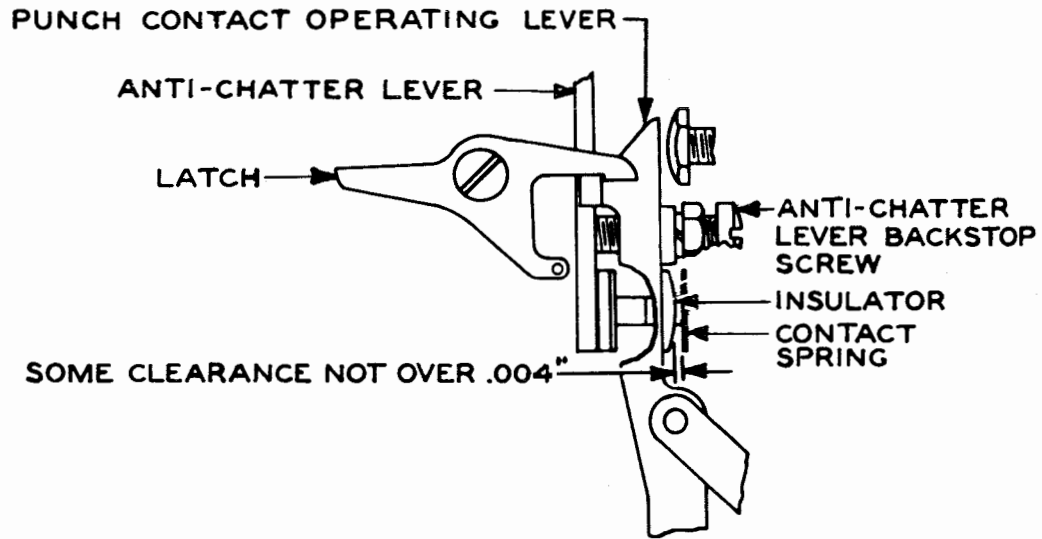

Figure 15

To Adjust: Position the antichatter-lever backstop screw in its mounting bracket.

To Adjust: Position the latch-operating screw in the magnet armature.

2.29 Latch Extension: There should be clearance, as specified in the figure between the latch and the latch extension on the punch-contact-operating lever with the magnet energized and the punch-operating contacts closed, and the punch-contact-operating lever held so that the latch extension on the lever is in line with the low surface of the latching tip on the latch. See Figure 16.

2.30 Positive-action Latch Spring should require a pull as specified in the figure to just start the positive-action latch moving away from the latch extension, when the punch-contact operating lever is resting against its backstop screw and the positive action latch is resting against the latch extension on the lever. See Figure 17.

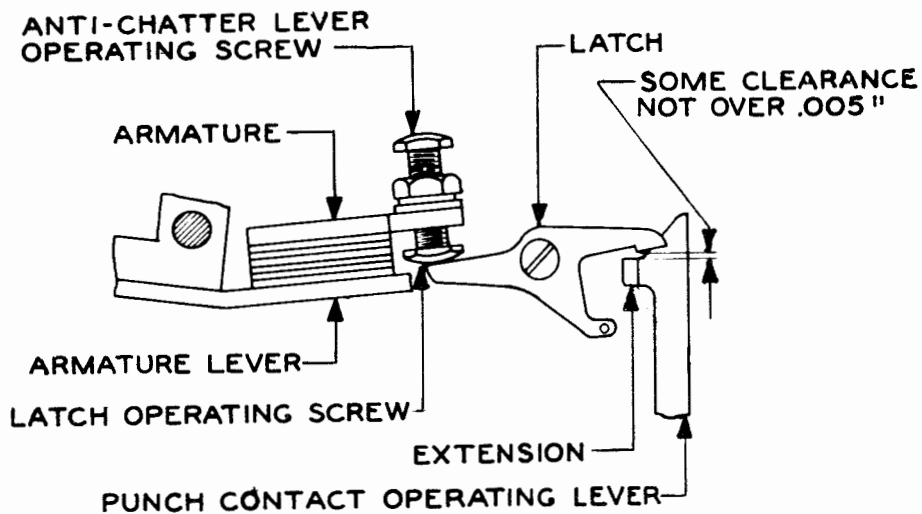

Figure 16

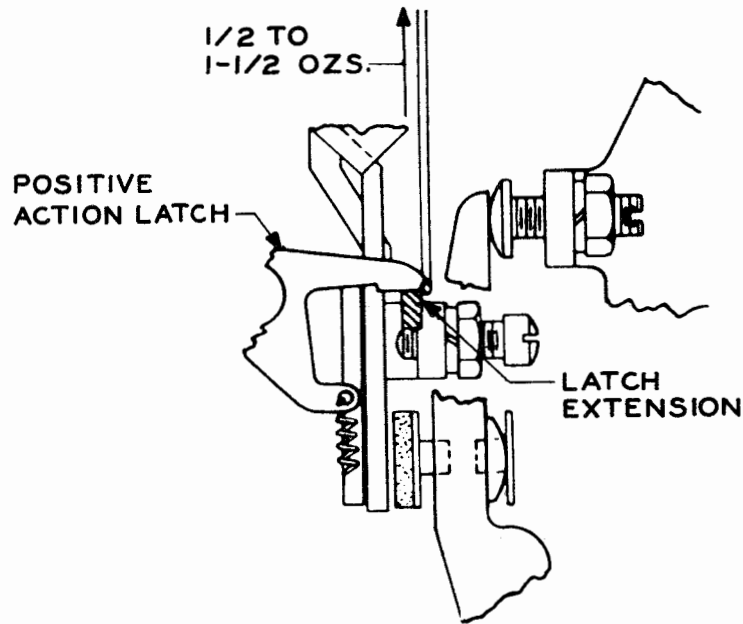

Figure 17

2.31 Antichatter Lever Spring should have such a tension that it requires a pull as specified in the figure to just start the antichatter lever moving away from its operating screw in the armature when the punch-magnet armature lever is resting firmly against its left stop and the antichatter lever operating screw is adjusted as in 2.27. See Figure 13.

2.32 Contact Points: For early closure and shallow touch the contact points should close when all punch-selector fingers just cover the full face of the punch pins.

To Gauge: Move the punch-selector fingers slowly under the punches from their extreme right (spacing) position by slowly depressing the LTRS keylever. Gauge by eye.

To Adjust: Shorten or lengthen the two-part adjustable link, by means of its elongated holes and clamping screws. See Figure 14.

2.33 Punch-magnet Control Contacts: For late closure and deep touch the punch-magnet control contacts should close so that there is no less than 0.015 inch clearance between the insulator on the punch-contact operating lever and the right (long) contact spring when any keylever is fully depressed until blocked by the A1 and A2 pair of code-selector bars.

To Check: See that there is clearance between the insulator on the left (short) contact spring and the antichatter lever. Try all keylevers including the space-bar keylever.

To Adjust: Shorten or lengthen the two-part adjustable link by means of its elongated holes and clamping screws. See Figure 14.

Note 1: Connect the perforator to a 115-volt dc source.

Note 2: The following adjustments apply to all perforators (2.34 through 2.70 inclusive).

2.34 Punch-contact Operating-lever Backstop Screw: There should be a clearance as specified in the figures between the contact-operating-lever backstop screw and the right edge of the contact-operating lever. See Figures 12 and 18.

To Gauge: Depress any keylever and then slowly release it until the punch contact points are just separated by the contact operating lever as it is pulled toward the right by the contact-operating lever retracting spring.

To Adjust: Position the screw.

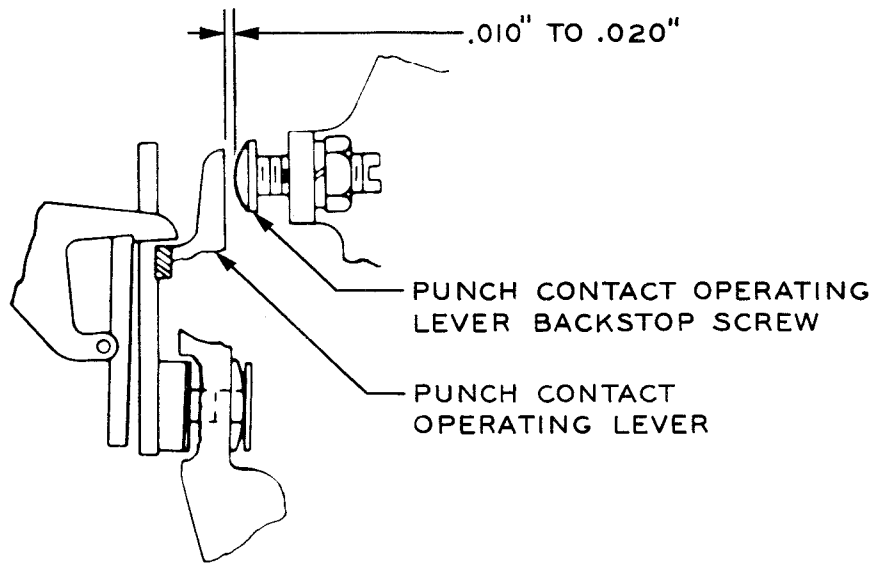

Figure 18

Note: Disconnect the perforator from the 115-volt dc source.

2.35 Punch-contact Operating-lever Return Spring: It should require a push as specified in the figure to just start the contact-operating lever moving away from the backstop screw when the right contact spring is allowed to bear freely against the fiber on the contact-operating lever. See Figure 11.

To Adjust: Turn the spring adjusting-screw to its highest position and position the spring-adjusting-lever extension.

2.36 Feed-pawl Eccentric: The feed pawl should engage a tooth on the feed roll without over-travel when the feed-punch-selector finger just touches the feed punch.

To Adjust: Position the feed-pawl-eccentric bushing to obtain the proper setting. See Figure 7.

2.37 Feed-pawl Spring: It should require a pull as specified below to stretch the spring to its installed length:

	Pull	
	Minimum	Maximum
1. Units equipped with TP99037 Set of Parts	3 pounds	4 pounds
2. Units not equipped with TP99037 Set of Parts	4-1/2 pounds	5-1/2 pounds

To Gauge: Unhook the lower end of the feed-pawl spring from its post and attach a scale. Pull downward. See Figure 7.

2.38 Feed-pawl Adjusting Bracket: When the armature lever is firmly against its left stop, the tip of the tooth on the feed pawl should clear the tips of the teeth on the feed roll by the amount specified in the figure throughout one complete revolution of the feed roll. Hold the detent roller away from the star wheel. See Figure 7.

To Adjust: Loosen the feed-pawl adjusting-bracket mounting screw and the adjusting-screw locknut. Secure them friction tight. With the adjusting screw in contact with the punch block, advance or withdraw the screw until the desired clearance is obtained.

Note: Connect the perforator to a 115-volt dc source.

2.39 Feed-pawl Guide: There should be a clearance as specified in the figure between the feed pawl and the closest feed-roll tooth when the punch contacts are closed. Check one full revolution of the feed roll while holding the detent roller away from the star wheel. See Figure 19.

To Adjust: Position the feed-pawl guide.

2.40 Punch-magnet Core: There should be clearance as specified in the figure between the magnet cores and the armature lever. See Figure 20.

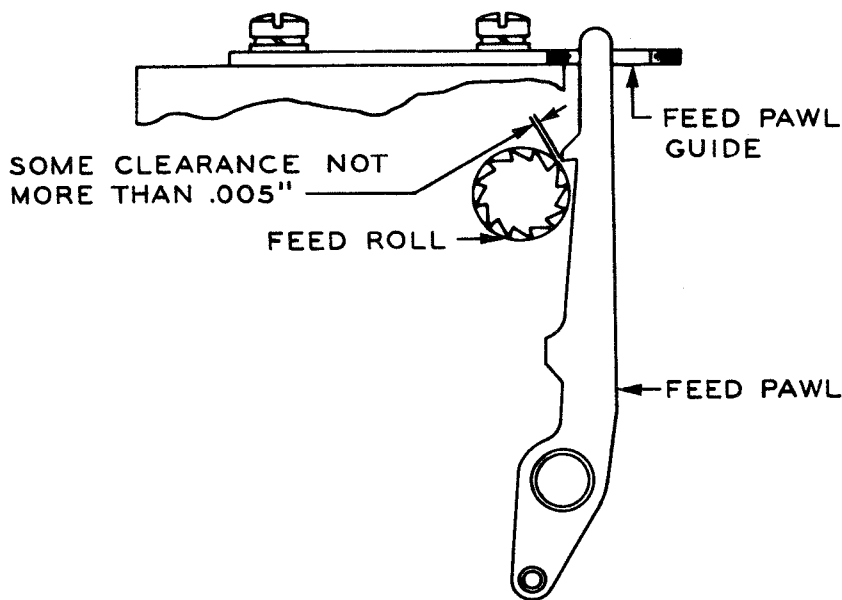

Figure 19

To Gauge: Depress any keylever and measure the gap.

Note: Adjustment is facilitated by removing the chad-chute cover plate on units with the counter mounted to the right of the keyboard or the counter mounting bracket on units with the counter mounted to the left of the keyboard.

To Adjust: Loosen the two eccentric-stop mounting screws and rotate them away from

the core. Loosen the magnet-core mounting screws and position the core. Tighten the mounting screws. Rotate the eccentrics so they make contact with the core. Tighten the eccentric screws. Put back the parts removed to make this adjustment.

Note 1: If clearance cannot be met, replace with eccentric TP89963.

Note 2: Put back the tape stripper and tape knife.

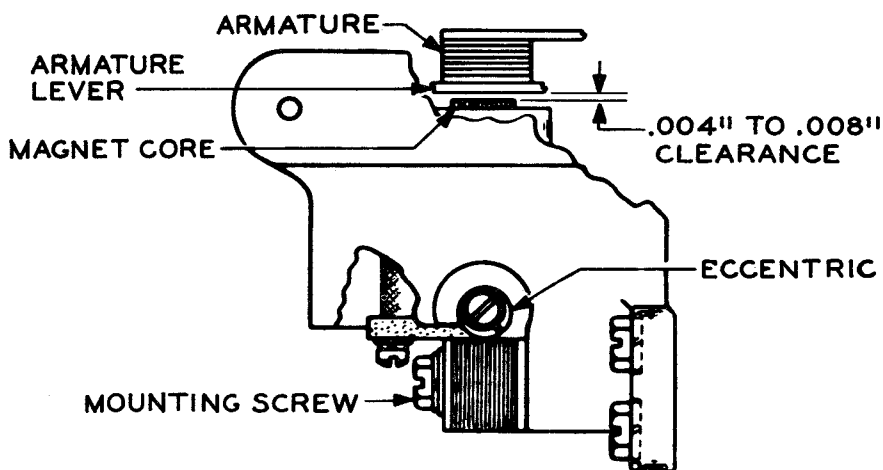

Figure 20

SECTION 572-201-700

2.41 Tape-stripper Plate upper edge should clear the feed roll as specified in the figure throughout a complete revolution of the roll. Gauge by eye.

To Adjust: Position the stripper plate. See Figure 21.

2.42 The Tape Knife should be approximately horizontal. There should be a clearance as specified in the figure between the tape knife and the tape stripper at their closest point. See Figure 21.

To Adjust: Position the knife.

2.43 Feed-roll Detent, Final Setting: The feed-hole perforations in the tape should conform to the standard spacing of 10 holes to the inch. Check the tape against the tape gauge (TP95960).

To Adjust: Loosen the detent-lever-eccentric-bushing mounting screw and position the bushing using the lower semicircle of its adjusting range. See Figure 6.

Note 1: If it is found necessary to refine this adjustment, recheck the feed-pawl eccentric and the feed-pawl adjusting-bracket adjustment.

Note 2: Disconnect the perforator from the 115-volt dc source.

COUNTER MECHANISMS (2.44 THROUGH 2.70 INCLUSIVE)

2.44 Counter-control-contact Operating Mechanism: The cam levers should be just completely displaced when the FIGS keylever and any two other keylevers are depressed until stopped by the selector bars. There should be little or no further displacement of the counter-control contact-operating fiber extension as the FIGS keylever is depressed to its full depth of stroke. Repeat this procedure using the CAR RET keylever instead of the FIGS keylever. It is important that full displacement of the cam lever is not reached until the function keylever just reaches its neutral position.

To Adjust: Add or remove shims between the counter-contact operating-mechanism casting and the bracket. See Figure 22.

Note: Shims extend under the condenser-mounting lugs.

2.45 Counter-control Contact-operating Cam Levers: There should be approximately equal clearance between the CAR RET and LF keylevers and the tips of their respective cam levers.

Gauge with the cam-lever links against their backstops (the unoperated position).

To Adjust: Position the counter-control contact-operating mechanism laterally by means of the elongated holes. See Figure 22.

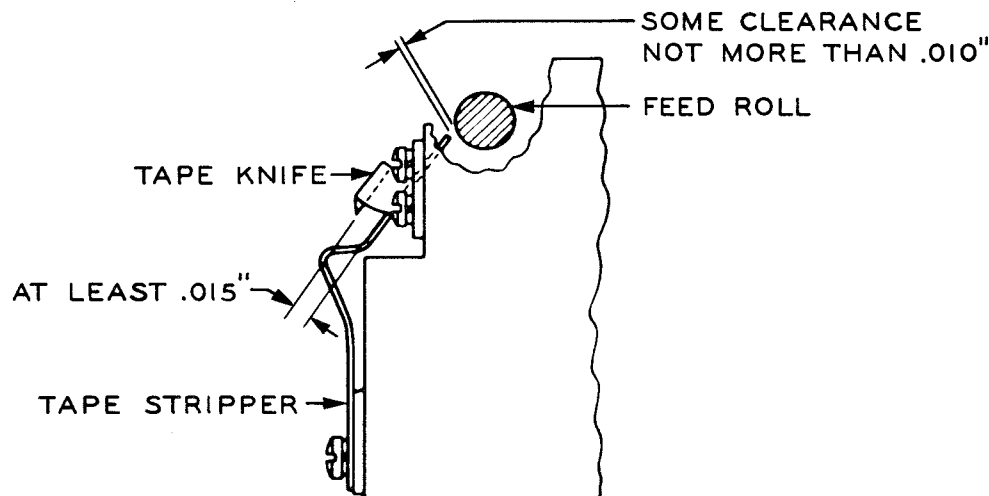

Figure 21

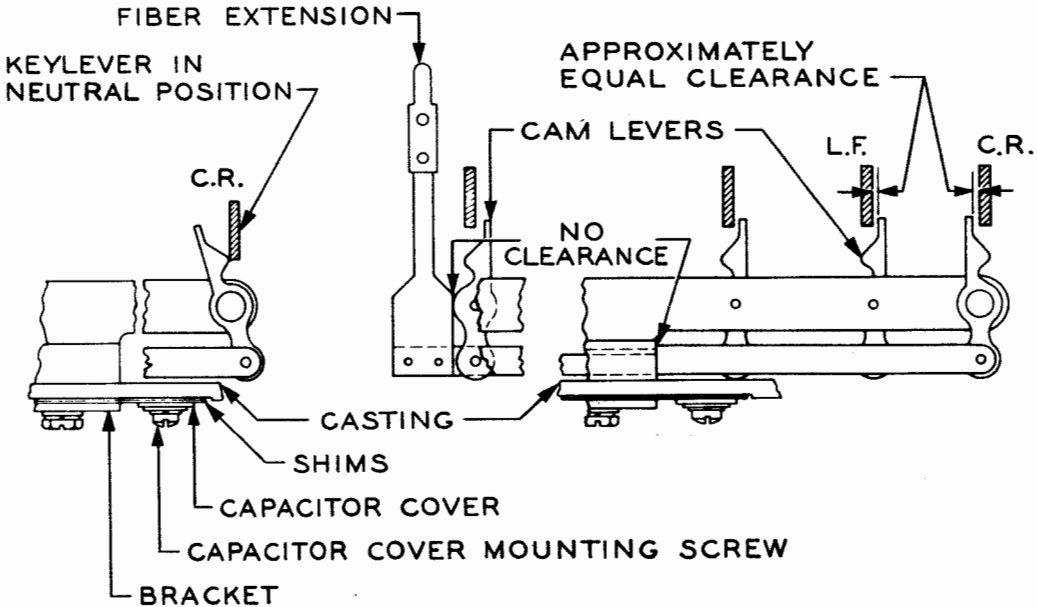

Figure 22

COUNTER-CONTROL-CONTACT ASSEMBLY:

Note: Remove the contact cover by loosening its mounting nuts. The contact springs are numbered from left to right with contact spring No.3 nearest to the resistor. In measuring the spring tensions, apply a scale to the

contact spring at the contact point and push or pull perpendicularly to the spring. See Figure 23.

2.46 Counter-contact Springs No.1 and No.2 should be approximately perpendicular to the insulator pile-up in the assembly. Each

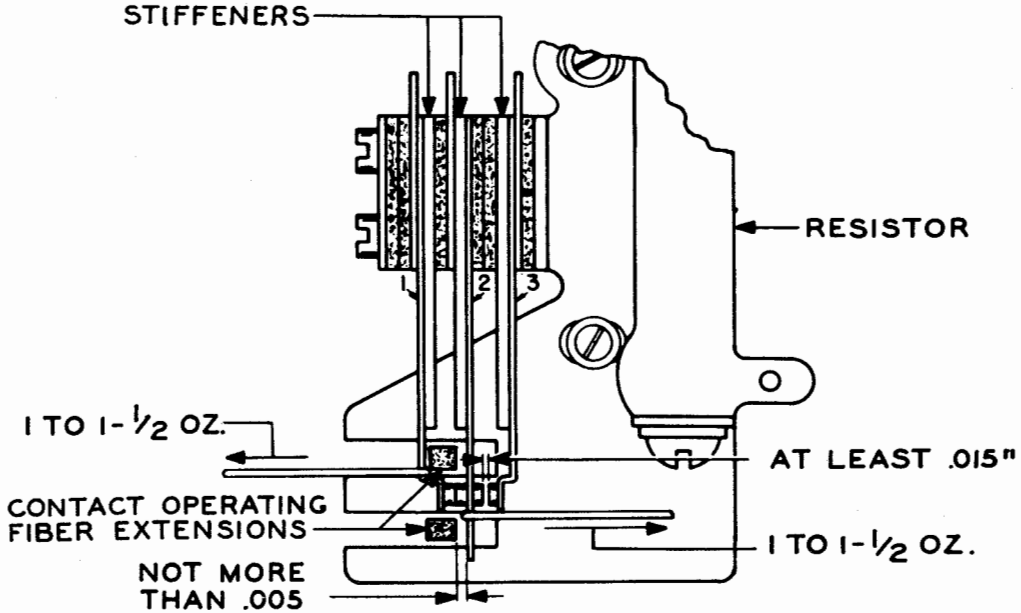

Figure 23

SECTION 572-201-700

counter contact point should have a follow of minimum 0.005 inch, maximum 0.010 inch when the mating spring is moved away.

To Adjust: Bend the stiffeners for contact springs No. 1 and No. 2. See Figure 23.

2.47 Counter-contact Springs: It should require a pull of minimum 1 ounce, maximum 1-1/2 ounces applied first to spring No. 1 then to spring No. 2 to just separate the contact points on contact springs No. 1 and No. 2.

To Adjust: Bend contact springs No. 1 or No. 2. Recheck the requirements in 2.46. See Figure 23.

2.48 Contact Operating Fiber Extensions should move freely in their guide slots. There should be a clearance as specified in the figure between contact spring No. 2 and the right edge of the fiber tip when the rear contact-operating fiber extension is held to its extreme right position. See Figure 23.

To Adjust: Position the counter-control-contact assembly by means of the elongated-bracket mounting holes.

2.49 Contact Spring No. 3 should be held by its stiffener so that when the CAR RET key-lever is depressed slowly, contact spring No. 3 will be moved minimum 0.005 inch, maximum 0.010 inch, by the action of the contact point on contact spring No. 2.

To Adjust: Bend the stiffener for contact spring No. 3. See Figure 23.

2.50 Counter-control Contacts on No. 2 and No. 3 springs should separate when a force of minimum 3/4 ounce, maximum 1 ounce is applied to the contact of the No. 3 spring when the CAR RET keylever is fully depressed.

To Adjust: Bend the No. 3 spring and recheck 2.49.

2.51 Counter-control Contacts: Gap between contacts on No. 2 and No. 3 springs should be at least 0.015 inch when the contact-operating fiber extensions are in their normal unoperated position.

Note: If adjustment is necessary, recheck 2.46 through 2.51 modifying adjustments so as to increase the gap.

2.52 Counter-control Contacts on the No. 1 and the No. 2 springs should break contact before the contacts on the No. 2 and No. 3 springs make contact when the CAR RET keylever is depressed slowly. Gauge by eye.

Note 1: If adjustment is necessary, refine the preceding adjustments so as to obtain break before make of contacts.

Note 2: Replace the contact cover. Hold the mounting screws with a screwdriver when tightening the nuts to avoid loosening the contact pile-up mounting screws.

Note 3: The character-counter adjustments are made from the rear and all instructions assume this point of view.

Note 4: If the counter unit is mounted at the right, remove the counter-unit-cover mounting screws from the under side of the mounting plate and remove the cover. Place the counter face down, to one side of the keyboard, without disconnecting the wires.

2.53 Feed-pawl Bracket: With the counting-magnet armature play taken up in an outward direction, the outer edge of the pawl should not extend more than 0.035 inch outside the outer surface of the ratchet. With the play taken up in the opposite direction, the outer surface of the pawl should not be more than 0.015 inch within the outer surface of the ratchet.

To Adjust: Remove the armature assembly from the unit. Set the screws which hold the bracket to the armature so that the bracket is friction tight, and put back the armature assembly on the unit. Adjust the bracket for the correct position of the pawl, remove the armature assembly, and tighten the bracket mounting screw. Replace the armature assembly. See Figure 24.

2.54 Ratchet Position and Dashpot Plunger Spring:

(1) The ratchet should be free throughout one complete revolution in a counterclockwise direction.

(2) With the dashpot removed, it should require minimum 1/2 ounce, maximum 1 ounce to move the plunger to its extreme inward position when the dashpot is held vertical with the plunger downward and the air-vent screw removed.

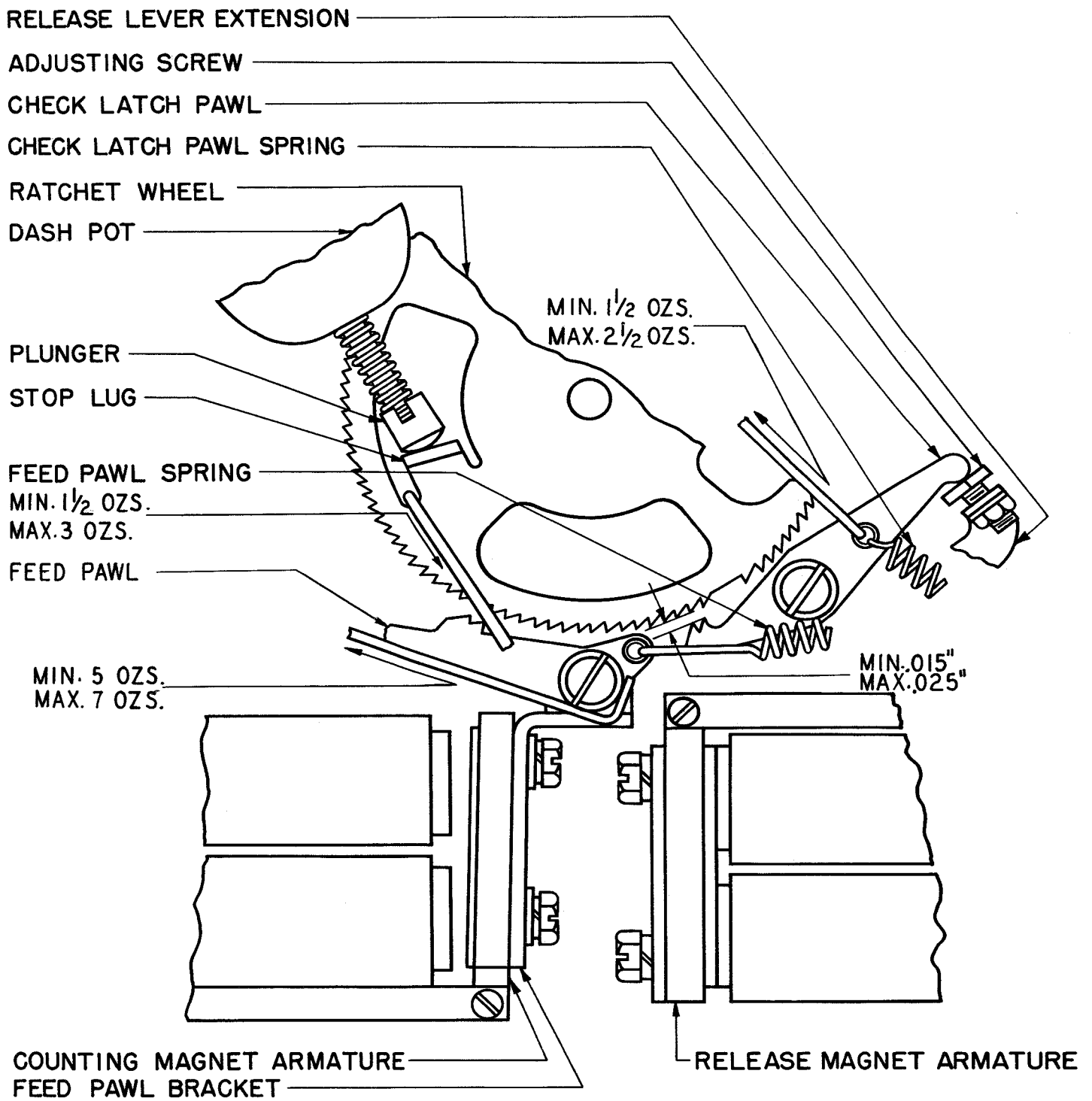

Figure 24

CAUTION: WHEN REMOVING THE DASHPOT TAKE CARE TO PREVENT THE RATCHET-WHEEL SPRING FROM UNWINDING RAPIDLY, WHICH MIGHT BREAK THE SPRING.

Note: The adjustment for requirement (1) above should be made with the dashpot removed while testing for requirement (2). Wind the ratchet spring by turning the ratchet in a counterclockwise direction until the spring is tight. Rotate the ratchet in a clockwise direction less than two but more than one complete revolution. Position the ratchet so the stop-lug is approximately in the center of the lower left-hand quadrant. Engage the latch pawl to hold the ratchet in place. Put back the dashpot and position it so the stop-lug

is in full engagement with the plunger throughout the plunger stroke. See Figure 24.

2.55 Ratchet-return Spring Tension: It should require a pull as specified in the figure to move the stop-lug away from the end of the plunger. See Figure 24.

To Gauge: Manually operate the release magnet and hold the dashpot plunger depressed. Pull in a counterclockwise direction as indicated in Figure 24.

2.56 Release-magnet-armature Eccentric (Stop): There should be a clearance as specified in the figure between the release-lever extension and the feed pawl when the release-magnet armature is against its eccentric (stop). See Figure 25.

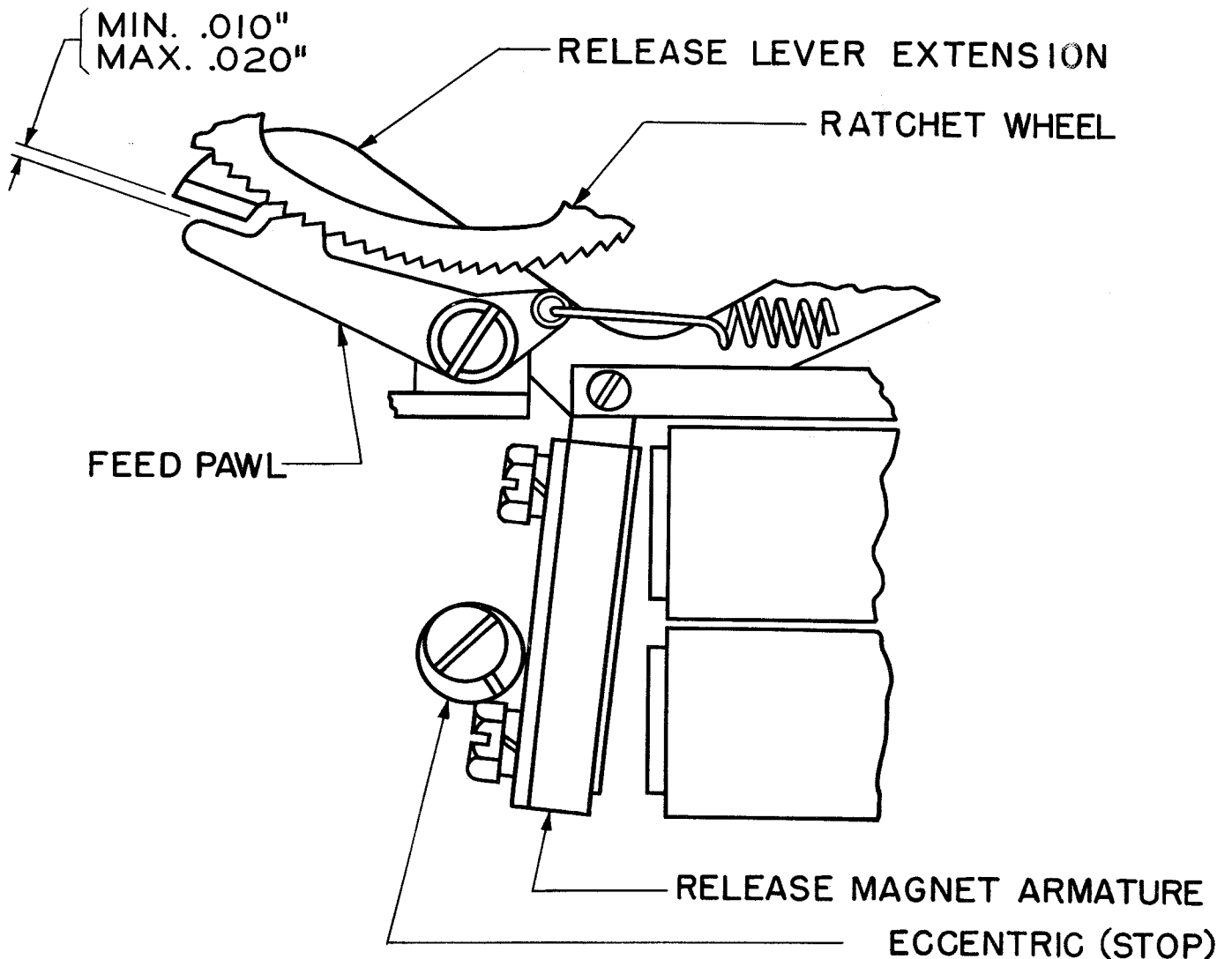

Figure 25

To Adjust: Loosen its screw and position the eccentric (stop).

2.57 Counting-magnet Check-latch-pawl Bracket: Counter feed-pawl teeth should over-travel the ratchet-wheel teeth by the amount specified in the figure when the counting-magnet armature is in its operated position (against the magnet cores). See Figure 26.

To Adjust: Back off the release-lever extension adjusting-screw, hold the check pawl in full engagement, and reposition the check-latch-pawl bracket.

2.58 Release-lever-extension Adjusting Screw: There should be a clearance as specified in the figure between the teeth on the check-latch pawl and the teeth on the ratchet when the release-magnet armature is manually held

against the magnet cores. Hold the ratchet so the teeth on the check-latch pawl are opposite the teeth on the ratchet. See Figure 24.

To Adjust: Position the release-lever extension adjusting screw.

2.59 Counting-magnet Armature-eccentric (Stop): Each operation of the counting-magnet should advance the ratchet one tooth and leave the check-latch pawl in full engagement with a tooth on the ratchet with a slight over-travel of not over 0.010 inch. Check this over-travel throughout a complete revolution of the ratchet.

To Adjust: Position the counting-magnet armature-eccentric (stop). See Figure 27.

2.60 Release-lever Extension should over-travel the notch in the release latch by the amount

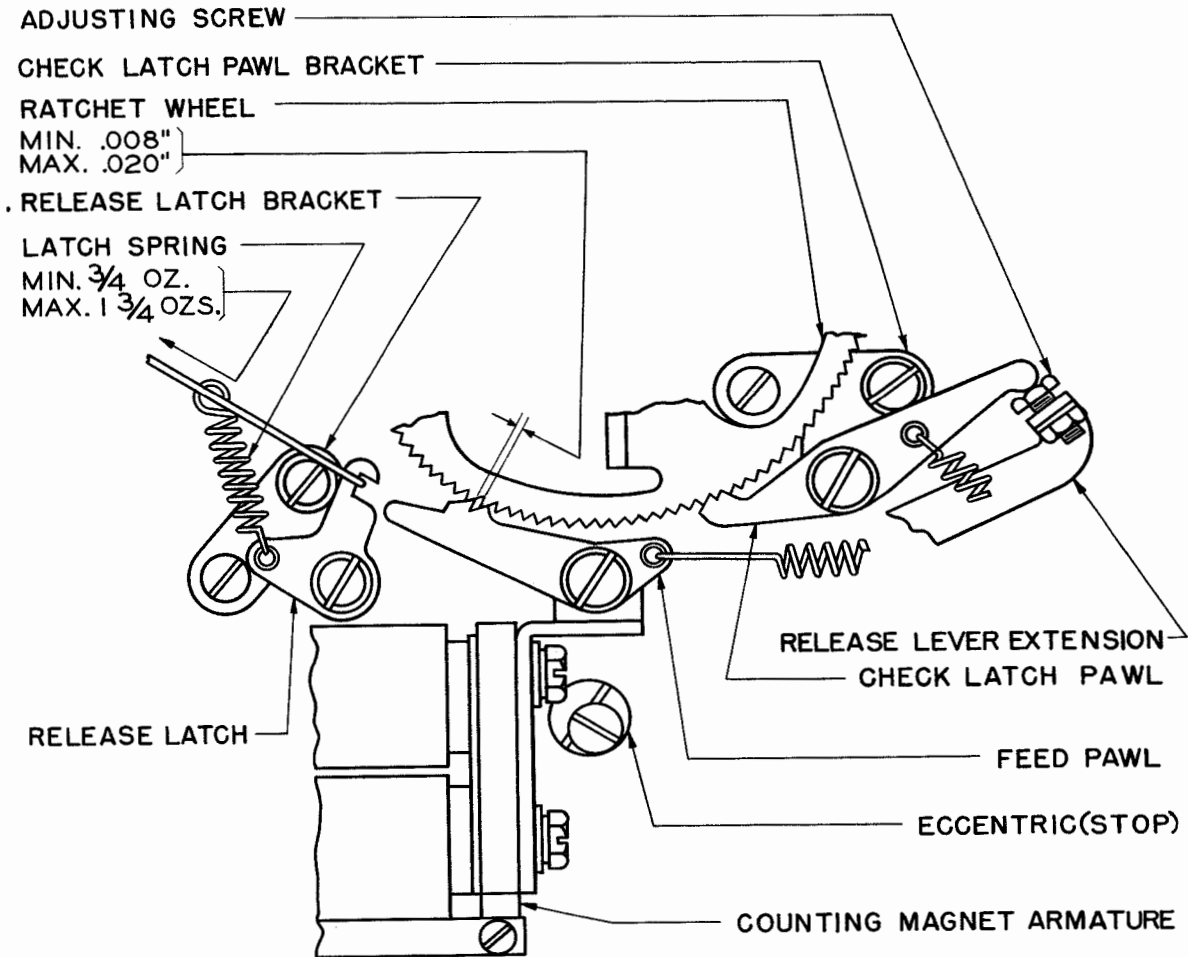

Figure 26

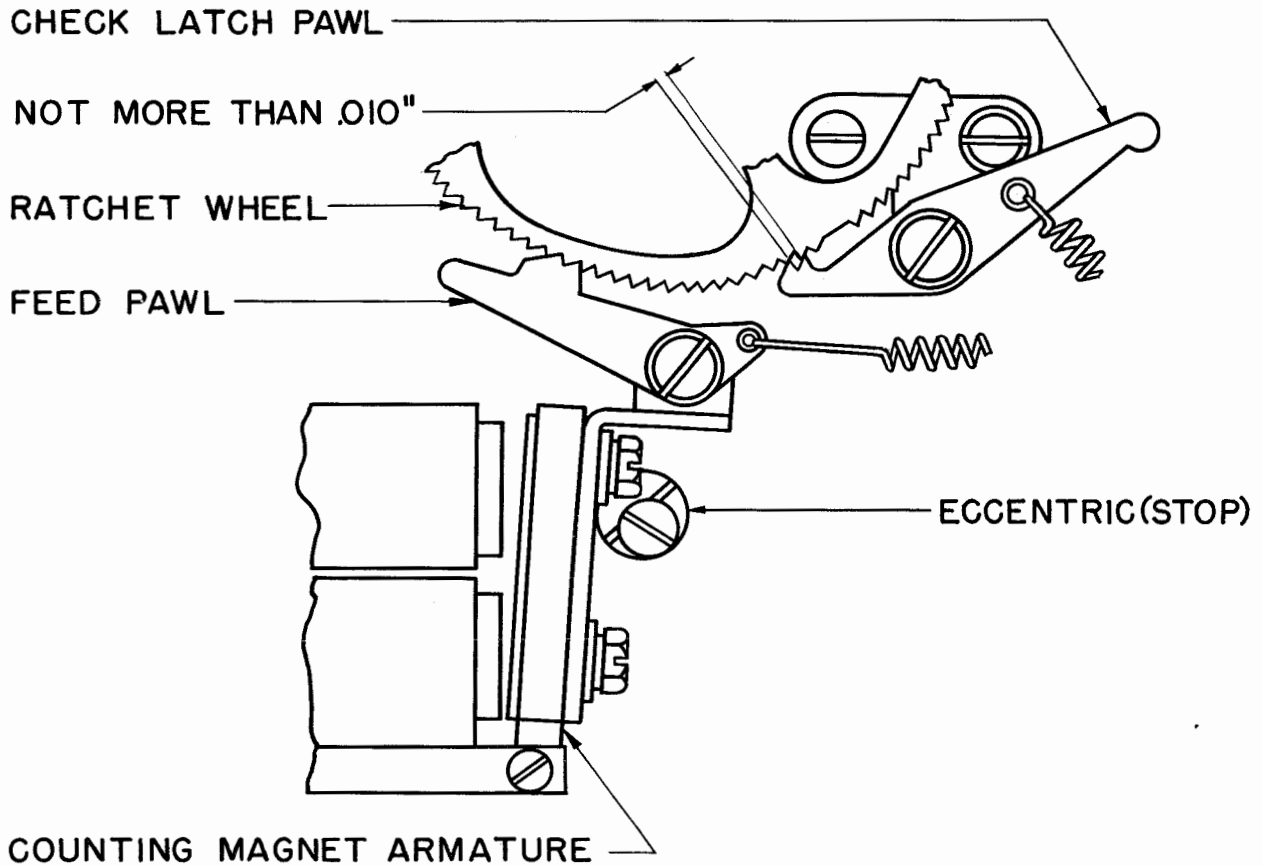

Figure 27

specified in the figure when the release magnet armature is in its operated position (against the cores).

To Adjust: Position the release-latch bracket. See Figure 28.

2. 61 Check-latch-pawl Spring should require a pull as specified in the figure to start the pawl moving when the release-magnet armature is in the operated position. See Figure 24.

2. 62 Release-latch Spring: It should require a tension as specified in the figure to start

the latch moving when the release latch is in its unlatched position. See Figure 26.

To Gauge: Hook a scale in the notch on the release latch. Pull in a direction such that the scale passes over the spring post.

2. 63 Dashpot:

- (1) With the plunger pushed into the dashpot cylinder the maximum amount, the stop-lug on the ratchet resting firmly against the end of the plunger and the check-latch pawl in

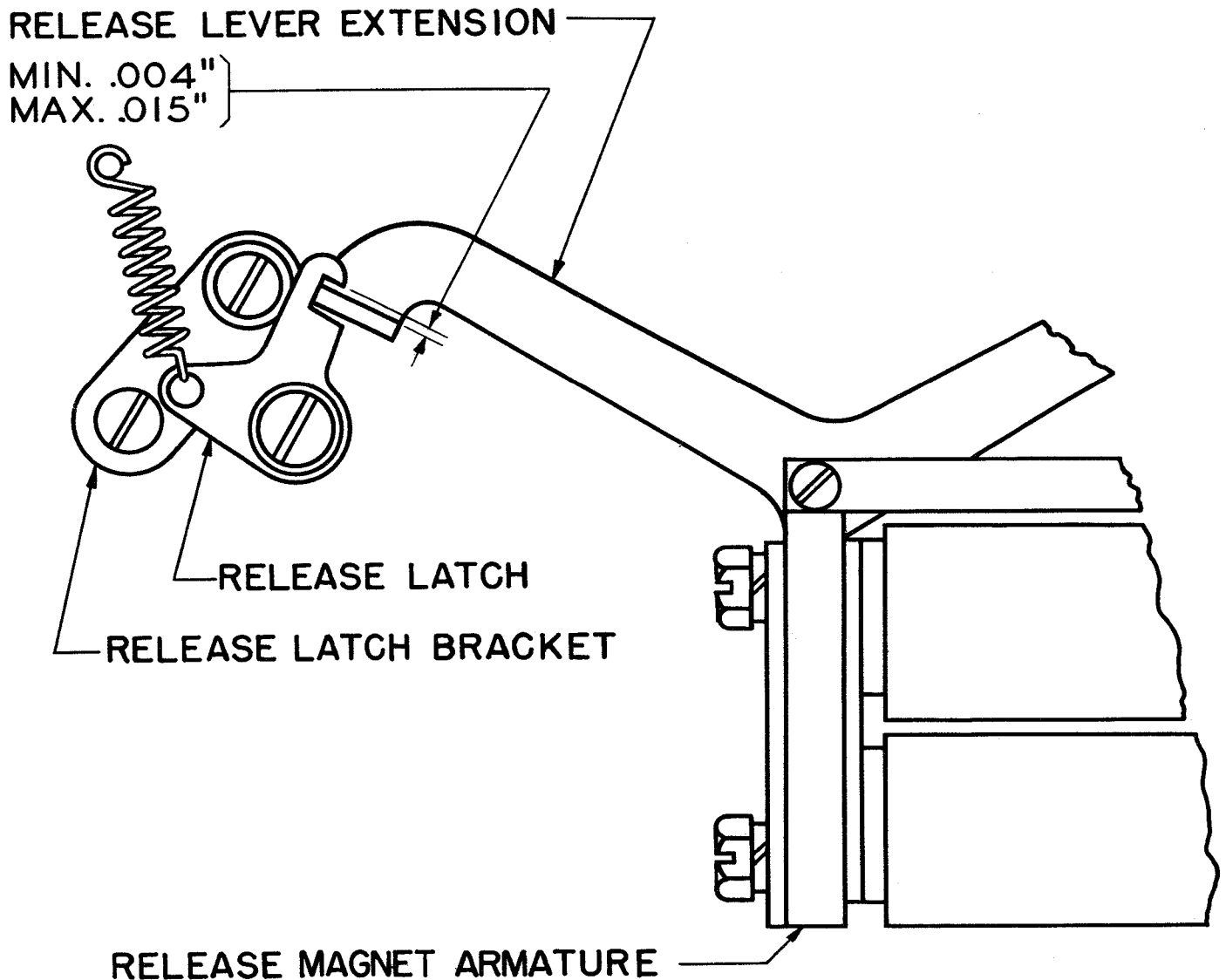

Figure 28

full engagement with the ratchet, there should be some, not over 0.004 inch clearance, between the engaging face of the first tooth on the ratchet and the face of the first (outer) tooth on the check-latch pawl.

(2) While the plunger is being pushed into the dashpot cylinder, the point of contact of the plunger against the ratchet stop-lug should be at least 0.040 inch from the edge of the stop-lug throughout the travel of the plunger.

To Adjust: Position the dashpot and recheck for requirement 2.54 (1).

(3) Under the conditions of (1) above, the indicator should point to zero on the dial.

To Adjust: Position the indicator, keeping the outer edge of the hub flush with the end of the shaft. See Figure 24.

2.64 Feed-pawl Spring: It should require a pull as specified in the figure to start the pawl moving. See Figure 24.

To Gauge: Hold the release-magnet armature against the magnet cores and hook a scale over the feed-pawl bearing screw.

Pull as nearly parallel as possible to the feed pawl.

2.65 Signal-lamp Short Contact-spring: The stiffener for this spring should be straight. The spring should rest against its stiffener throughout the length of the stiffener when the contact lever is on the low part of its cam. Gauge by eye.

Adjust by bending the short contact spring and stiffener. See Figure 29.

2.66 Signal-lamp Contact Springs: When the contact-operating lever is on the low part of its cam, the gap between contacts should be as specified in the figure. See Figure 29.

Adjust by bending the long lamp-contact spring.

2.67 Signal-lamp Contact Springs: When the contact-operating lever is on the low part of its cam, the insulator on the end of the long-contact spring should clear the contact-operating lever by the amount specified in the figure. See Figure 29.

Adjust by positioning the contact bracket.

2.68 Signal-lamp Contacts: It should require a pull as specified in the figure to separate

the contacts when the lamp-contact lever is on the high part of the cam. See Figure 30.

To Adjust: Bend the short lamp contact spring and recheck 2.65 and 2.66.

2.69 Signal-lamp Contact Cam: Rotate the ratchet to the first space (scale indicates zero). Operate the release-magnet armature and then the counting-magnet armature sixty-four times. The lamp contacts should close on the sixty-fifth operation.

To Adjust: Loosen the lamp-contact-cam setscrew and position the cam, simultaneously locating it so the ratchet shaft has some endplay, not over 0.004 inch. See Figures 24 and 30.

2.70 Dashpot-vent Screw: The ratchet wheel should return to zero position from the point of farthest travel without bouncing when operated under power and should return from the eighth position quickly enough to prevent feeding more than one space when a keylever is depressed immediately after the ratchet wheel has been released.

To Adjust: Position the dashpot-vent screw.

Note: Reassemble the counter cover.

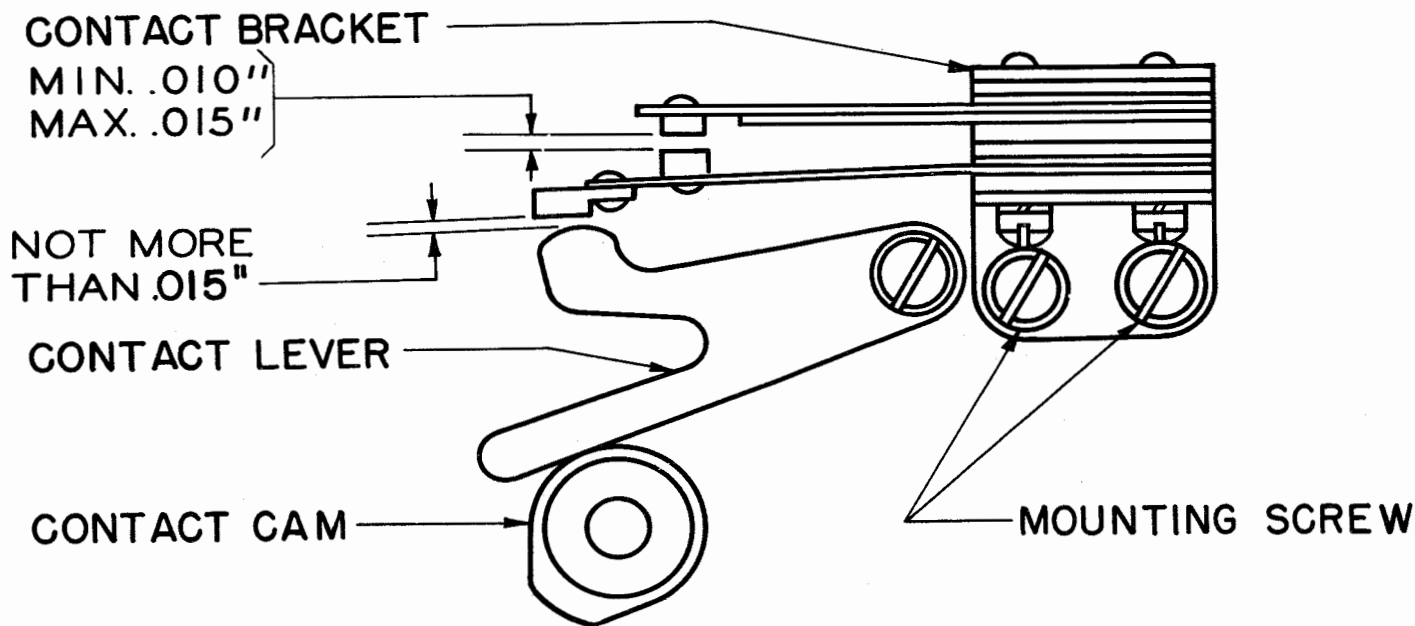

Figure 29

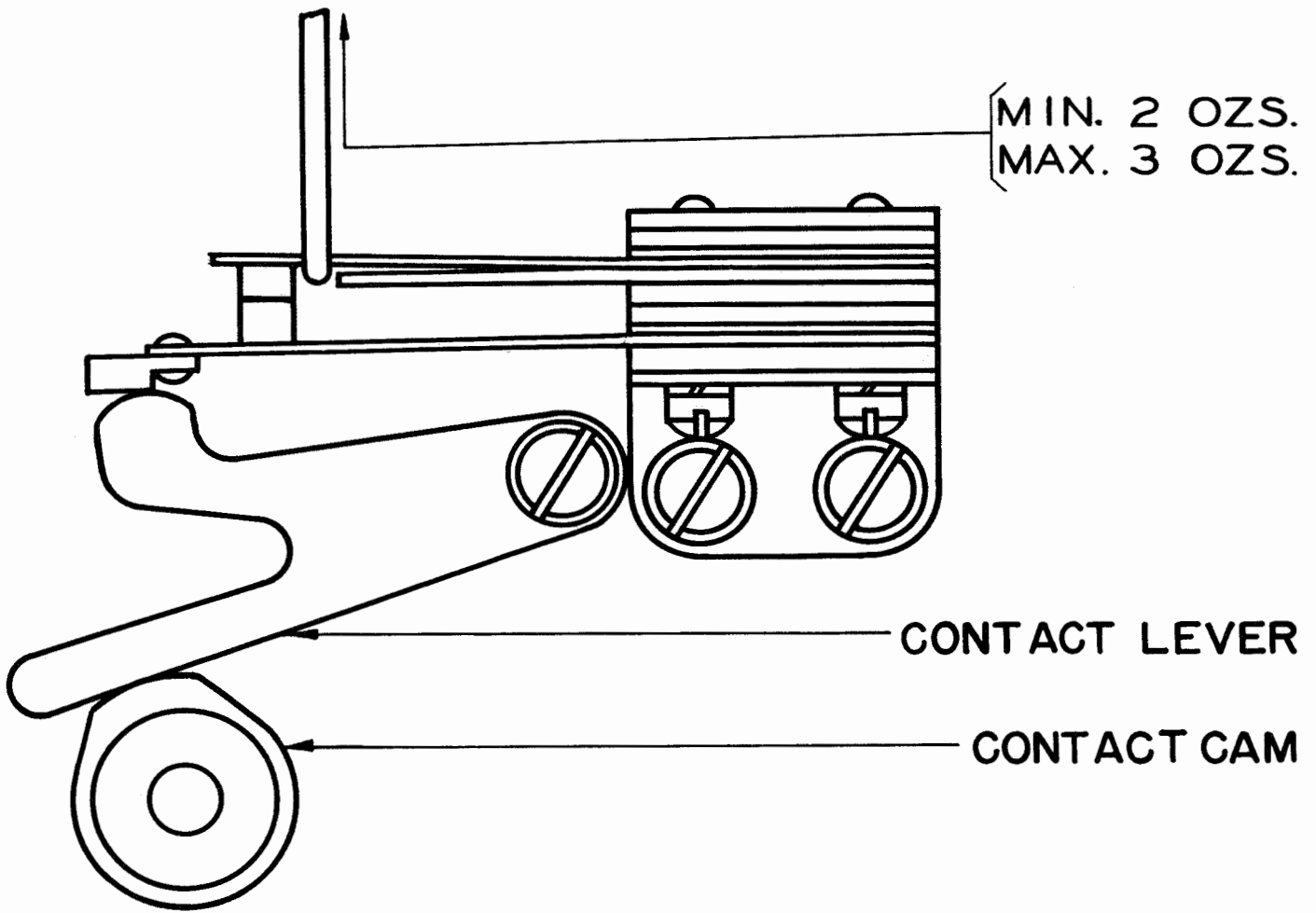

Figure 30