

★

NAVSHIPS 91393

INSTRUCTION BOOK  
*for*  
TELETYPEWRITERS  
TT-47/UG, TT-48/UG, TT-69/UG,  
AND TT-70/UG

TELETYPE CORPORATION  
CHICAGO, ILLINOIS

BUREAU OF SHIPS

NAVY DEPARTMENT

★

*Contracts: NObsr 42434  
NObsr 49182  
NObsr 52088  
NObsr 52089*

*Approved by BuShips: 7 December, 1950  
Change 1: 9 November, 1951*

## LIST OF EFFECTIVE PAGES

PAGE NUMBERS	CHANGE IN EFFECT	PAGE NUMBERS	CHANGE IN EFFECT
Title Page	Change 1	7-60	Change 1
A to B	Change 1	7-61 to 7-63	Original
C	Original	7-64	Change 1
i	Change 1	7-65 to 7-66	Original
ii to iii	Original	7-67 to 7-68	Change 1
iv to viii	Change 1	7-69	Original
ix to xiii	Original	7-70 to 7-72	Change 1
1-0	Original	7-73	Original
1-1 to 1-6	Change 1	7-74	Change 1
1-7	Original	7-75 to 7-76	Original
1-8	Change 1	7-77 to 7-78	Change 1
1-9 to 1-11	Original	7-79	Original
1-12 to 1-13	Change 1	7-80	Change 1
2-0	Change 1	7-81 to 7-85	Original
2-1 to 2-13	Original	7-86 to 7-87	Change 1
2-14	Change 1	7-88	Original
2-15 to 2-31	Original	7-89	Change 1
2-32	Change 1	7-90	Original
2-33 to 2-37	Original	7-91	Change 1
2-38	Change 1	7-92 to 7-95	Original
2-39	Original	7-96	Change 1
2-40 to 2-43	Change 1	7-97	Original
2-44 to 2-45	Original	7-98 to 7-101	Change 1
3-0 to 3-2	Original	7-102	Original
3-3	Change 1	7-103 to 7-117	Change 1
3-4 to 3-5	Original	7-118 to 7-119	Original
3-6	Change 1	7-120 to 7-122	Change 1
3-7 to 3-8	Original	7-123	Original
4-1 to 4-6	Original	7-124	Change 1
5-1 to 5-2	Original	7-125	Original
6-1 to 6-37	Original	7-126 to 7-127	Change 1
7-0	Original	7-128 to 7-129	Original
7-1	Change 1	7-130 to 7-132	Change 1
7-2 to 7-3	Original	7-133	Original
7-4 to 7-5	Change 1	7-134	Change 1
7-6 to 7-9	Original	7-135 to 7-137	Original
7-10 to 7-24	Change 1	7-138	Change 1
7-25	Original	7-139 to 7-142	Original
7-26 to 7-29	Change 1	7-143 to 7-146	Change 1
7-30 to 7-31	Original	8-1 to 8-2	Change 1
7-32	Change 1	8-3	Original
7-33 to 7-34	Original	8-4 to 8-190	Change 1
7-35 to 7-36	Change 1	8-191	Original
7-37 to 7-38	Original	8-192 to 8-198	Change 1
7-39 to 7-56	Change 1	i-1 to i-6	Change 1
7-57 to 7-59	Original	i-7 to i-8	Original

**TABLE OF CONTENTS**

<b>SECTION 1—GENERAL DESCRIPTION</b>		<i>Paragraph</i>	<i>Page</i>
<i>Paragraph</i>			
1. Scope of Instruction Manual .....	1-1	<i>e. Printing Mechanism</i> .....	2-16
2. Purpose of the Equipment .....	1-1	(1) Code Bar Mechanism .....	2-16
(1) Teletypewriter TT-47/UG .....	1-1	(a) General .....	2-16
(2) Teletypewriter TT-48/UG .....	1-1	(b) Code Bar Positioning .....	2-16
(3) Teletypewriter TT-69/UG .....	1-1	(c) Arrangement of Code Bars .....	2-16
(4) Teletypewriter TT-70/UG .....	1-1	(2) Type Box and Type Box Carriage ..	2-17
3. Description of Components .....	1-1	(a) General .....	2-17
<i>a.</i> Keyboard MX-1114/UG .....	1-1	(b) Positioning .....	2-19
<i>b.</i> Automatic Typer MX-1115/UG .....	1-2	(3) Printing Hammer and Printing	
<i>c.</i> Motors .....	1-3	Carriage .....	2-25
(1) AC Motor (Synchronous) PD-17/U	1-3	(a) General .....	2-25
(2) AC Motor (Synchronous) PD-17A/U	1-3	(b) Positioning .....	2-25
(3) AC Motor (Governed) PD-18/U ..	1-3	(c) Printing .....	2-25
<i>d.</i> Cabinets .....	1-4	<i>f. Spacing</i> .....	2-25
(1) General .....	1-4	(1) General .....	2-25
(2) Accessories .....	1-4A	(2) Spacing Suppression .....	2-25
<i>e.</i> Power Distribution Panel SB-154/UG ...	1-5	<i>g. Margin Indicator</i> .....	2-27
4. Reference Data .....	1-5	<i>b. Ribbon Mechanism</i> .....	2-27
<i>b.</i> Electrical Characteristics .....	1-11	(1) Positioning .....	2-27
(5) Power Supply Requirements .....	1-11	(2) Feeding .....	2-27
(a) AC Motors (Synchronous)		<i>i. Functions</i> .....	2-28
PD-17/U and PD-17A/U .....	1-12	(1) General .....	2-28
(b) AC Motor (Governed)		(2) Letters and Figures Shift Functions ..	2-33
PD-18/U .....	1-12	(3) Spacing Function .....	2-34
(c) Permissible Temperatures .....	1-12	(a) Spacing .....	2-34
		(b) Unshift On Space .....	2-34
		(4) Carriage Return Function .....	2-34
		(5) Line Feed Function .....	2-35
		(6) Automatic Carriage Return — Line	
		Feed Function .....	2-38
		(7) Signal Bell Function .....	2-39
		(8) Blank Function .....	2-39
		5. Motors .....	2-40
		<i>a.</i> AC Motor (Synchronous) PD-17/U .....	2-40
		<i>b.</i> AC Motor (Synchronous) PD-17A/U ...	2-41
		<i>c.</i> AC Motor (Governed) PD-18/U .....	2-41
		6. Power Distribution Panel SB-154/UG .....	2-43
		<i>b.</i> Basic Panel .....	2-43
		<i>c.</i> Electrical Motor Control .....	2-43
		(1) Stop Position .....	2-44
		(2) Open Line Position .....	2-45
		(3) Start Position .....	2-45
		(4) Stop Position .....	2-45
 <b>SECTION 2—THEORY OF OPERATION</b>			
1. General .....	2-1	<b>SECTION 3—INSTALLATION</b>	
2. Signaling Code .....	2-1	1. General .....	3-1
3. Keyboard MX-1114/UG .....	2-1	2. Unpacking the Equipment .....	3-1
<i>b.</i> Intermediate Shaft Assembly .....	2-2		
<i>c.</i> Code Bar Mechanism .....	2-3		
<i>d.</i> Signal Generator Mechanism .....	2-5		
<i>e.</i> Local Carriage Return Mechanism .....	2-8		
<i>f.</i> Local Line Feed .....	2-9		
<i>g.</i> Break Mechanism .....	2-9		
<i>h.</i> Repeat Mechanism .....	2-10		
<i>i.</i> Keyboard Lock Mechanism .....	2-10		
<i>j.</i> Keyboard Unlock Mechanism .....	2-11		
<i>k.</i> Margin Indicator Mechanism .....	2-11		
<i>l.</i> Time Delay Mechanism .....	2-11		
4. Automatic Typer MX-1115/UG .....	2-12		
<i>a.</i> Receiving Circuit .....	2-12		
<i>b.</i> Main Shaft .....	2-12		
<i>c.</i> Selecting Mechanism .....	2-13		
<i>d.</i> Orientation .....	2-15		

## TABLE OF CONTENTS—(Cont'd)

<i>Paragraph</i>	<i>Page</i>	<i>Paragraph</i>	<i>Page</i>
3. Installing the Cabinets .....	3-1	(b) Fuse Failure .....	7-1
4. Power and Line Connections .....	3-1	(2) Motor Does Not Stop .....	7-1
a. Cabinets TT-47/UG and TT-48/UG .....	3-1	(3) Irregular Motor Speed .....	7-1
b. Cabinets TT-69/UG and TT-70/UG .....	3-1	(4) No Signals From Keyboard .....	7-1
5. Assembly of Equipment .....	3-1	(a) Open Signal Line .....	7-1
a. Power Distribution Panel SB-154/UG .....	3-1	(b) Signal Line Not Opening .....	7-1
b. AC Motors PD-17/U and PD-18/U .....	3-4	(5) Short On Margin .....	7-1
c. Automatic Typewriter MX-1115/UG .....	3-4	(6) Intermittent Errors .....	7-2
(2) Initial Adjustments .....	3-4	(7) Gaining Or Losing A Pulse .....	7-2
d. Keyboard MX-1114/UG .....	3-4	(8) Garbling .....	7-2
6. Mechanical Checking of Equipment .....	3-5	(9) Spacing Failure Or Multiple Spacing .....	7-2
7. Operating Tests .....	3-5	(10) Failure On Letters-Figures Shift .....	7-2
8. Margin Indicating Lamp .....	3-6	(11) Failure On Carriage Return .....	7-2
9. Final Checks .....	3-6	(12) Failure On Line Feed .....	7-2
		(13) Failure On Signal Bell .....	7-3
		(14) Ribbon Fails To Feed Or Reverse .....	7-3
		(15) Failure To Position .....	7-3
		(16) Failure To Print .....	7-3
		3. Removal and Repair .....	7-3
		a. Automatic Typewriter .....	7-3
		(1) Type Box .....	7-3
		(2) Printing Carriage .....	7-4
		(3) Type Box Carriage .....	7-4
		(4) Front Plate .....	7-4
		(5) Function Box .....	7-4
		(6) Function Bar .....	7-5
		(7) Code Bars .....	7-5
		(8) Main Shaft .....	7-5
		(9) Upper Draw Wire Rope .....	7-5
		(b) Lower Draw Wire Rope .....	7-6
		(10) Platen .....	7-6
		(11) Selector Cam Clutch .....	7-6
		(12) Selector Mechanism .....	7-6
		(13) Code Bar Positioning Mechanism .....	7-7
		(14) Selector Magnet Assembly .....	7-7
		b. Keyboard .....	7-7
		(1) Signal Generator .....	7-7
		(2) Keyboard Selector Cam Assembly .....	7-7
		(3) Keyboard Label .....	7-8
		(4) Key Lever Cover .....	7-8
		(5) Key Lever .....	7-8
		(6) Space Bar .....	7-8
		(7) Key Lever Guide Plate .....	7-8
		(8) Keyboard Ball Lock Track .....	7-8
		(9) Keyboard Sealing Plate .....	7-8
		(10) Keyboard Code Bar Assembly .....	7-8
		(11) Code Bar .....	7-9
		(12) Motor .....	7-9
<b>SECTION 4 — OPERATION</b>			
1. Introduction .....	4-1		
2. On-Line Functions .....	4-1		
3. Off-Line Functions .....	4-2		
4. Characters Per Line .....	4-3		
5. Paper and Ribbon .....	4-3		
6. Multiple Copies .....	4-3		
7. Starting Procedure .....	4-3		
8. Speed Setting .....	4-3		
9. Orientation Range .....	4-4		
10. Summary of Operation .....	4-4		
11. Overload Cutout .....	4-6		
<b>SECTION 5 — OPERATOR'S MAINTENANCE</b>			
1. Routine Checks .....	5-1		
2. Emergency Maintenance .....	5-1		
a. Fuse Locations and Symptoms of Failure .....	5-1		
b. Replacement of Lamps .....	5-1		
<b>SECTION 6 — PREVENTIVE MAINTENANCE</b>			
1. General .....	6-1		
2. Routine Maintenance Check Charts .....	6-1		
3. Lubrication .....	6-1		
<b>SECTION 7 — CORRECTIVE MAINTENANCE</b>			
1. General .....	7-1		
2. Trouble Shooting .....	7-1		
a. General .....	7-1		
b. Tabulation of Faults Indicated in Chart Table 7-4 .....	7-1		
(1) Motor Does Not Start .....	7-1		
(a) Power Failure .....	7-1		

**TABLE OF CONTENTS—(Cont'd)**

(a) Synchronous .....	7-9	e. AC Motor PD-17/U .....	7-92
(b) Governed .....	7-9	f. AC Motor PD-18/U .....	7-94
4. Adjustments .....	7-9	g. Power Distribution Panel SB-154/UG ...	7-96
a. General .....	7-9	h. Cabinet CY-870/UG, CY-871/UG .....	7-97
b. Manual Selection of Characters		i. Final Test .....	7-99
Or Functions .....	7-9	5. Tools .....	7-99
c. Keyboard MX-1114/UG .....	7-10	6. Exploded Illustrations .....	7-99
d. Automatic Typewriter MX-1115/UG .....	7-40		

**SECTION 8—PARTS LISTS**

## LIST OF ILLUSTRATIONS

SECTION 1—GENERAL DESCRIPTION			<i>Figure</i>	<i>Title</i>	<i>Page</i>
<i>Figure</i>	<i>Title</i>	<i>Page</i>			
1-1	Teletypewriter Complete .....	1-0	2-22	Local Line Feed Mechanism .....	2-9
1-2	Keyboard MX-1114/UG, With Motor ...	1-2	2-23	Break Mechanism .....	2-10
1-3	Keyboard Keys .....	1-3	2-24	Break Mechanism .....	2-10
1-4	Automatic Typer MX-1115/UG, Front View .....	1-4	2-25	Repeat Mechanism .....	2-10
1-5	Automatic Typer MX-1115/UG, Rear View	1-5	2-26	Keyboard Lock Mechanism .....	2-10
1-6	Automatic Typer Front Plate .....	1-6	2-27	Keyboard Unlock Mechanism .....	2-11
1-7	Automatic Typer Main Shaft .....	1-6	2-28	Keyboard Lock Mechanism .....	2-11
1-8	Automatic Typer Function Box .....	1-7	2-29	Margin Indicator Mechanism .....	2-11
1-9	AC Motor PD-17/U, Synchronous .....	1-7	2-30	Time Delay Mechanism .....	2-12
1-9A	AC Motor PD-17A/U, Synchronous .....	1-8	2-31	Time Delay Mechanism .....	2-12
1-10	AC Motor PD-18/U, Governed .....	1-8	2-32	Time Delay Mechanism .....	2-12
1-11	Tilting Arrangement .....	1-9	2-33	Automatic Typer MX-1115/UG, Schematic Wiring Diagram .....	2-13
1-12	Cabinet CY-870/UG, With Power Distribu- tion Panel .....	1-10	2-34	Automatic Typer Main Shaft .....	2-14
1-13	Power Distribution Panel SB-154/UG ....	1-11	2-35	Clutch Disengaged .....	2-15
			2-36	Clutch Engaged .....	2-15
			2-37	Selector Cam Clutch Trip Mechanism ....	2-16
			2-38	Selecting Mechanism, Right End View ...	2-17
			2-39	Code Bar Positioning Mechanism .....	2-18
			2-40	Code Bar Positioning Mechanism, Front View .....	2-18
			2-41	Code Bar Positioning Mechanism, Top View .....	2-19
			2-42	Code Bar Arrangement .....	2-19
			2-43	Type Box Arrangement, Viewed From Front of Automatic Typer .....	2-20
			2-44	Draw Wire Rope Mechanism .....	2-21
			2-45	Trip Mechanism For Function and Type Box Clutches .....	2-21
			2-46	Right Side Mechanism .....	2-22
			2-47	Front Plate Horizontal Positioning Mechanism .....	2-23
			2-48	Stop Slide Positioning .....	2-24
			2-49	Printing Hammer Mechanism, Front View	2-26
			2-50	Printing Hammer Mechanism, Top View .	2-27
			2-51	Spacing Drum Drive Mechanism .....	2-27
			2-52	Spacing and Spacing Suppression Mechanism .....	2-28
			2-53	Spacing Cutout Mechanism .....	2-29
			2-54	Ribbon Mechanism, Left Side .....	2-29
			2-55	Ribbon Mechanism, Left Top View .....	2-29
			2-56	Ribbon Reversing Mechanism .....	2-29
			2-57	Function Box, Front View Showing Func- tion Bars .....	2-30
			2-58	Function Box, Rear View Showing Func- tion Levers .....	2-31

## SECTION 2—THEORY OF OPERATION

2-1	Teletypewriters TT-47/UG, TT-48/UG, TT-69/UG and TT-70/UG, Functional Block Diagram .....	2-0
2-2	Signal Code .....	2-1
2-3	Keyboard MX-1114/UG, Schematic Wiring Diagram .....	2-2
2-4	Code Bar Arrangement .....	2-3
2-5	Key Lever Lock Ball Mechanism .....	2-3
2-6	Key Lever Mechanism, Selected Position ..	2-4
2-7	Code Bar Bail Mechanism, Released Position .....	2-4
2-8	Code Bar Selection .....	2-5
2-9	Code Bar Bail Mechanism, Reset Position .	2-6
2-10	Clutch Trip Mechanism, View From Rear .	2-6
2-11	Non-Repeat Lever Mechanism .....	2-6
2-12	Keyboard Clutch Throwout Mechanism ..	2-6
2-13	Signal Generator Mechanism, Front View .	2-7
2-14	Signal Generator Mechanism, Front View .	2-7
2-15	Signal Generator Mechanism, Front View .	2-7
2-16	Signal Generator, Rear View, Stop Position	2-8
2-17	Signal Generator, Rear View, Spacing Position .....	2-8
2-18	Contact Assembly, Spacing Position .....	2-8
2-19	Signal Generator, Rear View, Marking Position .....	2-9
2-20	Contact Assembly, Marking Position .....	2-9
2-21	Local Carriage Return Mechanism .....	2-9

## LIST OF ILLUSTRATIONS — (Cont'd)

<i>Figure</i>	<i>Title</i>	<i>Page</i>	<i>Figure</i>	<i>Title</i>	<i>Page</i>
2-59	Function Reset Bail Mechanism . . . . .	2-32	4-2	Automatic Typewriter MX-1115/UG, Top View	4-2
2-60	Function Selection, Top View . . . . .	2-32	4-3	Power Distribution Panel SB-154/UG . . . . .	4-4
2-61	Typical Function Box Mechanism, Unselected . . . . .	2-32	4-4	Path of Paper . . . . .	4-5
2-62	Typical Function Box Mechanism, Selected	2-32	4-5	Path of Ribbon . . . . .	4-5
2-63	Letters-Figures Function Slides, Letters Position . . . . .	2-33	<b>SECTION 6 — PREVENTIVE MAINTENANCE</b>		
2-64	Letters-Figures Function Slides, Figures Position . . . . .	2-33	6-1	Cabinets CY-870/UG and CY-871/UG . . . . .	6-3
2-65	Letters-Figures Shift Mechanism, Letters Position . . . . .	2-34	6-2	Keyboard MX-1114/UG . . . . .	6-5
2-66	Unshift On Space Function Mechanism, Disabled Position . . . . .	2-34	6-3	Keyboard MX-1114/UG . . . . .	6-7
2-67	Carriage Return Function Mechanism . . . . .	2-35	6-4	Keyboard MX-1114/UG . . . . .	6-9
2-68	Carriage Return Mechanism . . . . .	2-36	6-5	Keyboard MX-1114/UG . . . . .	6-11
2-69	Line Feed Function and Clutch Trip Mechanism . . . . .	2-37	6-6	Keyboard MX-1114/UG . . . . .	6-13
2-70	Positioning Mechanism For Single or Double Line Feed . . . . .	2-38	6-7	Automatic Typewriter MX-1115/UG . . . . .	6-15
2-71	Line Feed Mechanism . . . . .	2-38	6-8	Automatic Typewriter MX-1115/UG . . . . .	6-17
2-72	Signal Bell Contact Mechanism, Unselected	2-39	6-9	Automatic Typewriter MX-1115/UG . . . . .	6-19
2-73	Signal Bell Contact Mechanism, Selected . . . . .	2-39	6-10	Automatic Typewriter MX-1115/UG . . . . .	6-21
2-74	Keyboard Lock Priming Mechanism . . . . .	2-39	6-11	Automatic Typewriter MX-1115/UG . . . . .	6-23
2-75	Keyboard Lock Mechanism . . . . .	2-40	6-12	Automatic Typewriter MX-1115/UG . . . . .	6-25
2-76	AC Motor (Synchronous) PD-17/U, Schematic Wiring Diagram . . . . .	2-40	6-13	Automatic Typewriter MX-1115/UG . . . . .	6-27
2-76A	AC Motor (Synchronous) PD-17A/U, Schematic Wiring Diagram . . . . .	2-41	6-14	Automatic Typewriter MX-1115/UG . . . . .	6-29
2-77	AC Motor (Governed) PD-18/U, Schematic Wiring Diagram . . . . .	2-42	6-15	Automatic Typewriter MX-1115/UG . . . . .	6-31
2-78	Governor For AC Motor PD-18/U . . . . .	2-42	6-16	Automatic Typewriter MX-1115/UG . . . . .	6-33
2-79	Power Distribution Panel SB-154/UG and Cabinets CY-870/UG and CY-871/UG, Schematic Wiring Diagram . . . . .	2-42A	6-17	Automatic Typewriter MX-1115/UG . . . . .	6-35
2-80	Electrical Motor Control Mechanism, Stop Position . . . . .	2-44	<b>SECTION 7 — CORRECTIVE MAINTENANCE</b>		
2-81	Electrical Motor Control Mechanism, Open Line Position . . . . .	2-44	7-1	Keyboard, Signal Generator, Front View . . . . .	7-10
2-82	Electrical Motor Control Mechanism, Start Position . . . . .	2-45	7-2	Keyboard, Signal Generator, Front View . . . . .	7-11
<b>SECTION 3 — INSTALLATION</b>			7-3	Keyboard, Signal Generator, Rear View . . . . .	7-12
3-1	Primary Power Distribution Diagram . . . . .	3-0	7-4	Keyboard, Signal Generator, Rear View . . . . .	7-13
3-2	Power and Signal Line Connections . . . . .	3-2	7-5	Keyboard, Signal Generator, Rear View . . . . .	7-14
3-3	Power Distribution Panel Connections . . . . .	3-3	7-6	Keyboard, Signal Generator, Rear View . . . . .	7-15
3-4	System Pictorial Diagram . . . . .	3-5	7-7	Keyboard, Clutch Mechanism . . . . .	7-16
3-5	Outline and Mounting Dimensions . . . . .	3-7	7-8	Keyboard, Clutch Mechanism . . . . .	7-17
<b>SECTION 4 — OPERATION</b>			7-9	Keyboard, Clutch Mechanism . . . . .	7-18
4-1	Keyboard Keys . . . . .	4-1	7-10	Keyboard, Contact Box . . . . .	7-19
			7-11	Keyboard, Code Bar Reset Mechanism . . . . .	7-20
			7-12	Keyboard, Reset Bail and Repeat Slide . . . . .	7-21
			7-13	Keyboard, Non-Repeat Mechanism . . . . .	7-22
			7-13A	Keyboard, Non-Repeat Mechanism . . . . .	7-23
			7-14	Keyboard, Code Bar Mechanism . . . . .	7-23
			7-15	Keyboard, Reset Mechanism . . . . .	7-24
			7-16	Keyboard, Code Lever Bail . . . . .	7-25
			7-17	Keyboard, Space Bar . . . . .	7-26
			7-18	Keyboard, Key Lever Locking Mechanism . . . . .	7-27
			7-19	Keyboard, Time Delay Mechanism . . . . .	7-28
			7-20	Keyboard, Time Delay Mechanism . . . . .	7-29
			7-21	Mounting Typewriter on Keyboard . . . . .	7-30
			7-22	Typewriter and Signal Generator Gearing . . . . .	7-31
			7-23	Keyboard and Motor Gearing . . . . .	7-32
			7-24	Keyboard, Local Line Feed Mechanism . . . . .	7-33

## LIST OF ILLUSTRATIONS—(Cont'd)

<i>Figure</i>	<i>Title</i>	<i>Page</i>	<i>Figure</i>	<i>Title</i>	<i>Page</i>
7-25	Keyboard, Local Carriage Return Mechanism .....	7-34	7-56	Automatic Typer, Horizontal Motion Reversing Mechanism .....	7-64
7-26	Keyboard Lock Mechanism .....	7-35	7-57	Automatic Typer, Shift Slide Drive Mechanism .....	7-65
7-27	Keyboard, Time Delay Mechanism .....	7-36	7-58	Automatic Typer, Vertical Positioning Mechanism .....	7-66
7-28	Keyboard, Time Delay Disabling Device ..	7-37	7-59	Automatic Typer, Spacing Mechanism ...	7-67
7-29	Keyboard, Label Cover, Plastic Window ..	7-38	7-60	Automatic Typer, Spacing Mechanism ...	7-68
7-30	Keyboard, Margin Indicating Mechanism ..	7-39	7-61	Automatic Typer, Carriage Return Mechanism .....	7-69
7-31	Automatic Typer, Selector Magnet .....	7-40	7-62	Automatic Typer, Carriage Return Mechanism .....	7-70
7-32	Automatic Typer, Selector Magnet .....	7-41	7-63	Automatic Typer, Carriage Return Mechanism .....	7-71
7-32A	Automatic Typer, Selector Magnet .....	7-41	7-64	Automatic Typer, Dashpot and Keyboard Lock Mechanisms .....	7-72
7-33	Automatic Typer, Selector Mechanism ...	7-42	7-65	Automatic Typer, Type Box Mechanism ..	7-73
7-34	Automatic Typer, Selector Cam Clutch ..	7-43	7-66	Automatic Typer, Right Margin and Drive Linkage Mechanisms .....	7-74
7-35	Automatic Typer, Transfer Mechanism ..	7-44	7-67	Automatic Typer, Printing Carriage .....	7-75
7-36	Automatic Typer, Code Bar Shift Mechanism .....	7-45	7-68	Automatic Typer, Shift Mechanism .....	7-76
7-37	Automatic Typer, Code Bar Shift Mechanism .....	7-46	7-69	Automatic Typer, Printing Mechanism ..	7-77
7-38	Automatic Typer, Code Bar Shift Mechanism .....	7-47	7-70	Automatic Typer, Printing Mechanism ..	7-78
7-39	Automatic Typer, Selector Clutch Operating Bail .....	7-48	7-71	Automatic Typer, Ribbon Reverse Mechanism .....	7-79
7-40	Automatic Typer, Selector Clutch Mechanism .....	7-49	7-72	Automatic Typer, Ribbon Feed Mechanism .....	7-80
7-41	Automatic Typer, Code Bar Clutch Trip Shaft Mechanism .....	7-50	7-73	Automatic Typer, Shift Mechanism .....	7-81
7-42	Automatic Typer, Function Clutch Mechanism .....	7-51	7-74	Automatic Typer, Function Box .....	7-82
7-43	Automatic Typer, Trip Shaft Mechanism ..	7-52	7-75	Automatic Typer, Line Feed Mechanism ..	7-83
7-44	Automatic Typer, Spacing Clutch Mechanism .....	7-53	7-76	Automatic Typer, Function Pawl Stripper Mechanism .....	7-84
7-45	Automatic Typer, Type Box Clutch and Line Feed Clutch Mechanism .....	7-54	7-77	Automatic Typer, Spacing Suppression Mechanism .....	7-84
7-46	Automatic Typer, Type Box Clutch Mechanism .....	7-55	7-78	Automatic Typer, Function Pawl Stripper Mechanism .....	7-85
7-47	Automatic Typer, Clutch Shoe Mechanism, All Clutches .....	7-55	7-79	Automatic Typer, Automatic Carriage Return Mechanism .....	7-86
7-48	Automatic Typer, Clutch Mechanism ....	7-56	7-80	Automatic Typer, Paper Mechanism .....	7-87
7-49	Automatic Typer, Spacing Mechanism ...	7-57	7-81	Automatic Typer, Paper Mechanism .....	7-88
7-50	Automatic Typer, Line Feed and Rocker Shaft Mechanism .....	7-58	7-82	Automatic Typer, Bell Contact .....	7-89
7-51	Automatic Typer, Shift and Positioning Mechanism .....	7-59	7-83	Automatic Typer, Unshift-On-Space Mechanism .....	7-90
7-52	Automatic Typer, Vertical Positioning Mechanism, Right .....	7-60	7-84	Automatic Typer, Code Bar Detent Mechanism .....	7-91
7-53	Automatic Typer, Vertical Positioning Mechanism, Left .....	7-61	7-85	Motor Position .....	7-92
7-54	Automatic Typer, Spacing Mechanism ...	7-62	7-86	Centrifugal Mechanism .....	7-92
7-55	Automatic Typer, Function Reset Bail Extension Arm .....	7-63	7-87	Starting Switch .....	7-93
			7-88	Motor Governor .....	7-94



## LIST OF ILLUSTRATIONS — (Cont'd)

<i>Figure</i>	<i>Title</i>	<i>Page</i>	<i>Figure</i>	<i>Title</i>	<i>Page</i>
7-89	Motor Governor Brush .....	7-95	7-118	Automatic Typer, Selector Magnet Assembly .....	7-123
7-90	Motor Control Assembly .....	7-96	7-119	Automatic Typer, Selector Mechanism ...	7-124
7-91	Remote Signal Bell .....	7-97	7-120	Automatic Typer, Front Plate Mechanism	7-125
7-92	Window and Accessories .....	7-98	7-121	Automatic Typer, Front Plate .....	7-126
7-93	Tools .....	7-101	7-122	Automatic Typer, Front Plate Mechanism	7-127
7-94	Keyboard, Time Delay Mechanism .....	7-102	7-123	Automatic Typer, Spring Drum Mechanism .....	7-128
7-95	Keyboard, Base Mechanism .....	7-103	7-124	Automatic Typer, Trip Shaft Mechanism.	7-129
7-96	Keyboard, Code Bar Mechanism .....	7-104	7-125	Automatic Typer, Main Shaft Mechanism.	7-130
7-97	Keyboard, Intermediate Gear Mechanism.	7-105	7-125A	Automatic Typer, Main Shaft Mechanism.	7-130A
7-98	Keyboard, Carriage Return Mechanism ..	7-105	7-126	Automatic Typer, Right Side Linkage and Type Box .....	7-131
7-99	Keyboard Lock Mechanism .....	7-105	7-127	Automatic Typer, Paper Spindle and Reset Bail .....	7-132
7-100	Keyboard, Local Line Feed Mechanism ..	7-105	7-128	Automatic Typer, Line Feed and Platen Mechanism .....	7-133
7-101	Keyboard Mechanism .....	7-106	7-129	Automatic Typer, Left Side Linkage and Stripper Blade .....	7-134
7-102	Keyboard, Signal Generator Mechanism ..	7-107	7-130	Automatic Typer, Space Suppression Mechanism .....	7-135
7-103	Keyboard, Signal Generator Mechanism ..	7-108	7-131	Automatic Typer, Pressure Roller Mechanism .....	7-136
7-104	Keyboard, Signal Generator Mechanism ..	7-109	7-132	Automatic Typer, Right Side Frame Mechanism .....	7-137
7-105	Keyboard, Signal Generator Mechanism ..	7-110	7-133	Automatic Typer, Left Side Frame Mechanism .....	1-138
7-106	Synchronous Motor, PD-17/U .....	7-111	7-134	Automatic Typer, Code Bar Positioning Mechanism .....	7-139
7-106A	Synchronous Motor, PD-17A/U .....	7-112	7-135	Primary Power Distribution Diagram ...	7-140
7-107	Governed Motor, PD-18/U .....	7-112A	7-136	Schematic Wiring Diagram, TT-47/UG, TT-48/UG, TT-69/UG and TT-70/UG .	7-143
7-108	Governor Mechanism .....	7-113	7-137	Wiring Diagram, TT-47/UG, TT-48/UG, TT-69/UG and TT-70/UG .....	7-145
7-109	Cabinet .....	7-114			
7-110	Cabinet .....	7-115			
7-111	Power Distribution Panel .....	7-116			
7-112	Power Distribution Panel, Motor Control Mechanism .....	7-117			
7-113	Automatic Typer, Printing Carriage ....	7-118			
7-114	Automatic Typer, Code Bar Mechanism ..	7-119			
7-115	Automatic Typer, Left Ribbon Feed Mechanism .....	7-120			
7-116	Automatic Typer, Right Ribbon Feed Mechanism .....	7-121			
7-117	Automatic Typer, Function Box .....	7-122			

**LIST OF TABLES****SECTION 1—GENERAL DESCRIPTION**

<i>Table</i>	<i>Title</i>	<i>Page</i>
1-1	Equipment Supplied .....	1-12
1-2	Shipping Data .....	1-13
1-3	Equipment Required but not Supplied .....	1-13

**SECTION 5—OPERATOR'S MAINTENANCE**

5-1	Routine Check Chart .....	5-1
5-2	Symptoms of Fuse Failure .....	5-2
5-3	Fuse Locations .....	5-2

**SECTION 6—PREVENTIVE MAINTENANCE**

6-1	Routine Maintenance Check Chart .....	6-2
-----	---------------------------------------	-----

**SECTION 7—CORRECTIVE MAINTENANCE**

<i>Table</i>	<i>Title</i>	<i>Page</i>
7-1	Selector Margins .....	7-99
7-2	List of Tools .....	7-100
7-3	Winding Data .....	7-100
7-4	Trouble Shooting Chart .....	7-141

**SECTION 8—PARTS LISTS**

8-1	Weights and Dimensions of Spare Parts Boxes .....	8-2
8-2	Shipping Weights and Dimensions of Spare Parts Boxes (Not Applicable) .....	8-2
8-3	List of Major Units .....	8-2
8-4	Combined Parts and Spare Parts List .....	8-4
8-5	Cross Reference Parts List .....	8-192
8-6	List of Manufacturers .....	8-198

**SECTION 1**  
**GENERAL DESCRIPTION**

**1. SCOPE OF INSTRUCTION BOOK.**

This instruction book describes the TT-47/UG, TT-48/UG, TT-69/UG, and TT-70/UG Teletypewriters and includes information concerning their installation, adjustment, operation and maintenance.

**2. PURPOSE OF THE EQUIPMENT.**

a. The Teletypewriters described herein are used to exchange typewritten page messages between two or more distant points when connected by a telegraph channel. The operating speed is in the order of 368 o.p.m. (operations per minute), which is generally referred to as 60 words per minute speed. The speed may be increased to 75 or 100 words per minute by changing gears. Signaling between stations is accomplished electrically by use of the five-unit start-stop permutation code and utilizes the 7.42 unit transmission pattern.

b. The units comprising Teletypewriters described herein are as follows:

- (1) TELETYPEWRITER TT-47/UG.
- |                              |                 |
|------------------------------|-----------------|
| (a) Cabinet                  | Type CY-870/UG  |
| (b) Power Distribution Panel | Type SB-154/UG  |
| (c) Keyboard                 | Type MX-1114/UG |
| (d) AC Motor                 | Type PD-17/U    |
| (e) Automatic Typewriter     | Type MX-1115/UG |
| (f) Set of Gears             | 151060          |

**Note**

AC Motor Type PD-17/U is replaced by AC Motor Type PD-17A/U starting with Serial Number 76 of Teletypewriter TT-47/UG.

- (2) TELETYPEWRITER TT-48/UG.
- |                              |                 |
|------------------------------|-----------------|
| (a) Cabinet                  | Type CY-870/UG  |
| (b) Power Distribution Panel | Type SB-154/UG  |
| (c) Keyboard                 | Type MX-1114/UG |
| (d) AC Motor                 | Type PD-18/U    |
| (e) Automatic Typewriter     | Type MX-1115/UG |
| (f) Set of Gears             | 151060          |
- (3) TELETYPEWRITER TT-69/UG.
- |                              |                 |
|------------------------------|-----------------|
| (a) Cabinet                  | Type CY-871/UG  |
| (b) Power Distribution Panel | Type SB-154/UG  |
| (c) Keyboard                 | Type MX-1114/UG |
| (d) AC Motor                 | Type PD-17/U    |

- |                          |                 |
|--------------------------|-----------------|
| (e) Automatic Typewriter | Type MX-1115/UG |
| (f) Set of Gears         | 151060          |
- (4) TELETYPEWRITER TT-70/UG.
- |                              |                 |
|------------------------------|-----------------|
| (a) Cabinet                  | Type CY-871/UG  |
| (b) Power Distribution Panel | Type SB-154/UG  |
| (c) Keyboard                 | Type MX-1114/UG |
| (d) AC Motor                 | Type PD-18/U    |
| (e) Automatic Typewriter     | Type MX-1115/UG |
| (f) Set of Gears             | 151060          |

**Note**

AC Motor Type PD-17/U is replaced by AC Motor Type PD-17A/U starting with Serial Number 76 of Teletypewriter TT-69/UG.

c. It should be noted that the TT-47/UG and the TT-48/UG equipments include a cabinet for deck mounting and motors of the synchronous and governed types respectively, while the TT-69/UG and TT-70/UG include a cabinet for bulkhead shelf mounting and the same synchronous and governed motors respectively.

d. The apparatus is equipped with a motor control feature which stops the motor every time that the signal line becomes idle for a period not longer than approximately two minutes. The motors start in response to a momentary opening of the signal line at any point on the circuit or to the reception of code signals. This feature may be readily disabled when not required.

e. The equipment is wired for operation on 0.060 ampere signal line current at the factory but is adaptable to 0.020 ampere current by making a convenient wiring change in the Power Distribution Panel.

f. Messages are ordinarily typed on single-copy paper eight and one-half inches wide. However, paper of lesser varying width (minimum three inches) may be used.

**3. DESCRIPTION OF COMPONENTS.**

a. KEYBOARD MX-1114/UG. (See figure 1-2.)—The Keyboard supports the AC Motor and the Automatic Typewriter, and incorporates code selecting and signal generating mechanisms. Signal line and power line circuits are also included. A delay mechanism for stopping the motor on extended idle periods of the signal line is connected in the Keyboard but may be disabled if not

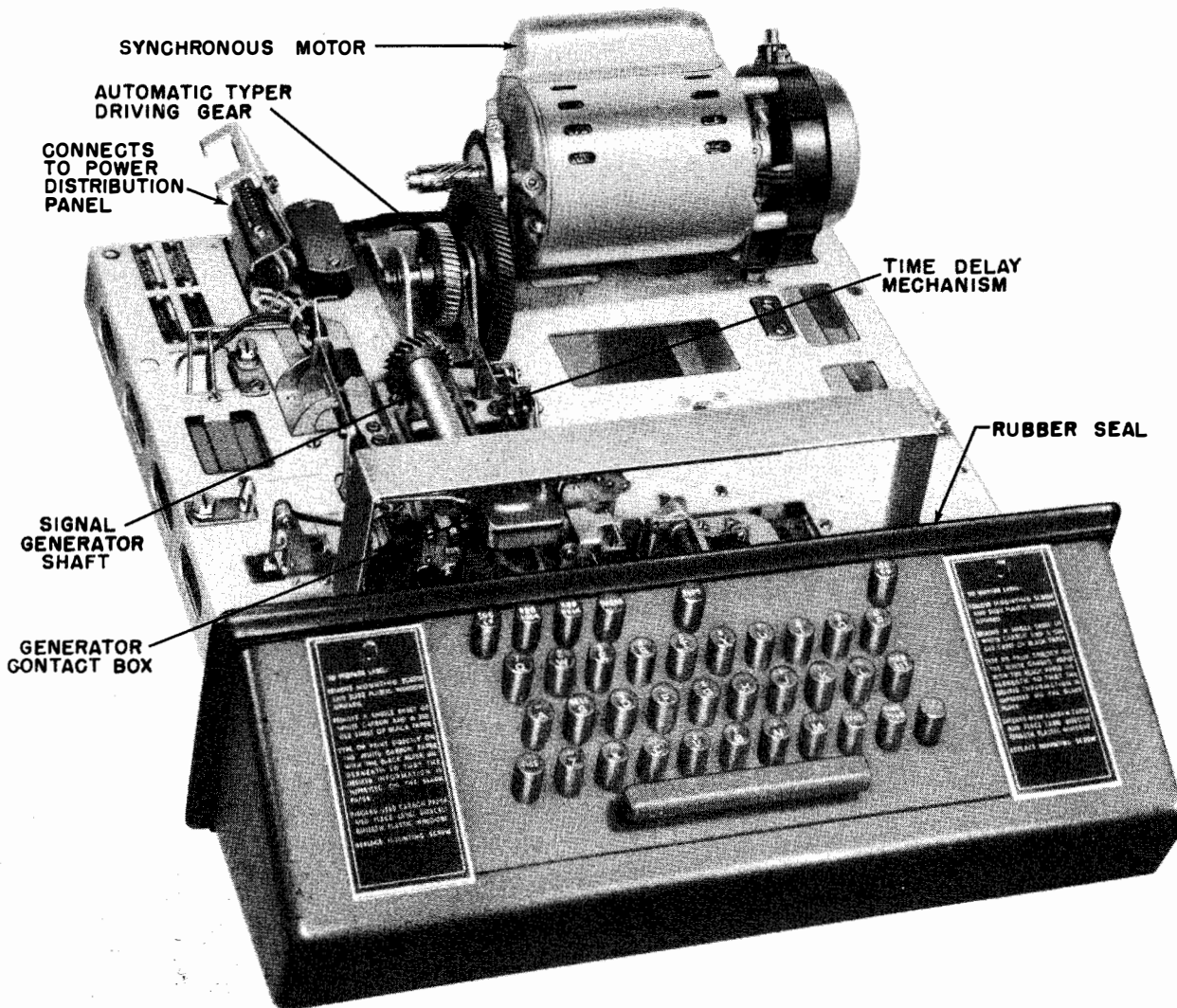


Figure 1-2. Keyboard MX-1114/UG, With Motor

required. The keys are positioned in the conventional three-bank arrangement with numerals, punctuation marks and special symbols available in upper case positions (figure 1-3). Special keys (red) for line break, keyboard lock and unlock, repeat operation, and local carriage return and line feed are located directly above the standard keys (green) for facility of operation. The Keyboard with the Automatic Typer and AC Motor mounted in position is placed upon rails within the Cabinet. The front of the Keyboard protrudes beyond the Cabinet and is fitted with a rubber pad that seals the edges of the aperture for a silencing effect. Motive force for activating the Keyboard is derived from the AC Motor by way of the Automatic Typer.

b. AUTOMATIC TYPER MX-1115/UG. (See figures 1-4 and 1-5.)

(1) The Automatic Typer incorporates the necessary electrical and mechanical features for translating the code signals into mechanical action in order to

record the message and perform the usual functions incident thereto.

(2) Code signals are applied to a two-coil magnet associated with selecting mechanism which interprets the signal and controls the motions involved in typing a character or performing a required function. Means is provided for orienting the selector to the received signal. The AC Motor is geared to the main shaft of the Automatic Typer which in turn, extends motion to the Keyboard mechanism. The typing and various functional sections of the Automatic Typer are activated by individual clutches that completely disengage at the termination of each operating cycle and thus reduce the motor load to the minimum when idling.

(3) Paper feeds from a four and one-half inch diameter roll mounted on the Automatic Typer and passes around a stationary platen. Provisions are made for readily converting to sprocket type feed for fan-fold forms which may be used optionally in conjunction with

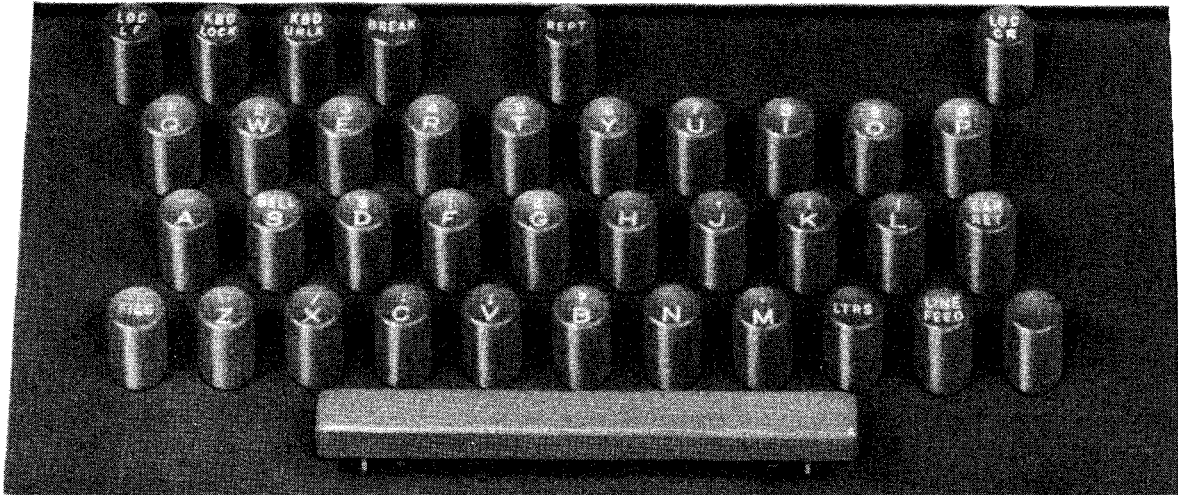


Figure 1-3. Keyboard Keys

friction feed paper. Interchanging of Automatic Typewriter subassemblies involves the minimum in readjusting procedure (figures 1-6, 1-7, 1-8). Type pallets are arranged in a compact, lightweight type box which may be readily detached for cleaning or quick replacement by another type box. In operation, the type box keeps step with a printing carriage and presents the proper type pallets to the printing hammer to receive the printing strokes as the printing carriage advances along the line. Combined automatic carriage return and line feed operate to return the carriages in case over-printing occurs at the end of a line.

(4) In addition to the conventional functions common to teletypewriters, built-in facilities permit the addition of selective station call or recognition functions with electrical circuits associated therewith available for remote extension. In such applications the Automatic Typewriter may be stripped of all typing and paper feeding mechanisms and utilized for circuit switching or similar applications.

c. MOTORS.—The motors are self-contained components that mount on the rear of the Keyboard base and have characteristics adaptable to standard power supplies.

(1) AC MOTOR (SYNCHRONOUS) PD-17/U. (See figure 1-9.)

(a) The AC Motor, PD-17/U, is a wound stator, two-pole, single phase synchronous motor with split phase starting. A centrifugal switch associated with the starting winding of the motor is housed within a handwheel on an extension of the motor shaft to facilitate repair or replacement. A capacitor that increases the starting torque is attached to the side of the stator. A thermal overload device (manually reset) that protects the motor windings is also located on the stator.

(b) The motor proper is supported by a cradle to which it is held by latches at each end. Resilient mounts on the hubs of the motor end caps reduce transmission of vibration to the Keyboard.

(2) AC MOTOR (SYNCHRONOUS) PD-17A/U. (See figure 1-9A.)

(a) The AC Motor, PD-17A/U, is a wound stator, two pole, single phase, capacitor start, synchronous motor. A combination handwheel and fan is mounted on one end of the motor shaft. A motor starting relay and capacitor, together with a thermal cutout switch are mounted in a compartment on the underside of the motor. The thermal cutout switch (manually reset) serves to protect the motor windings from excessive heating.

(b) The motor proper is supported by a cradle to which it is held by straps at each end. Resilient mounts on the hubs of the motor end bells reduce transmission of vibration to the Keyboard.

(3) AC MOTOR (GOVERNED) PD-18/U. (See figure 1-10.)

(a) The AC Motor, PD-18/U is series wound and is similar to the synchronous motor in its mounting arrangement.

(b) A combined governor and fan are positioned on the motor shaft extension. The fan aids in controlling the temperature rise by drawing cooling air through the motor. A target for speed checking purposes is painted on the governor cover. The cover also serves to protect the governor mechanism. A screwdriver opening is provided in the cover to facilitate speed adjustments. Brush filter capacitors are provided within the motor end bells.

(c) The entire AC Motor, PD-18/U is shielded to minimize radio interference. A shielded compartment

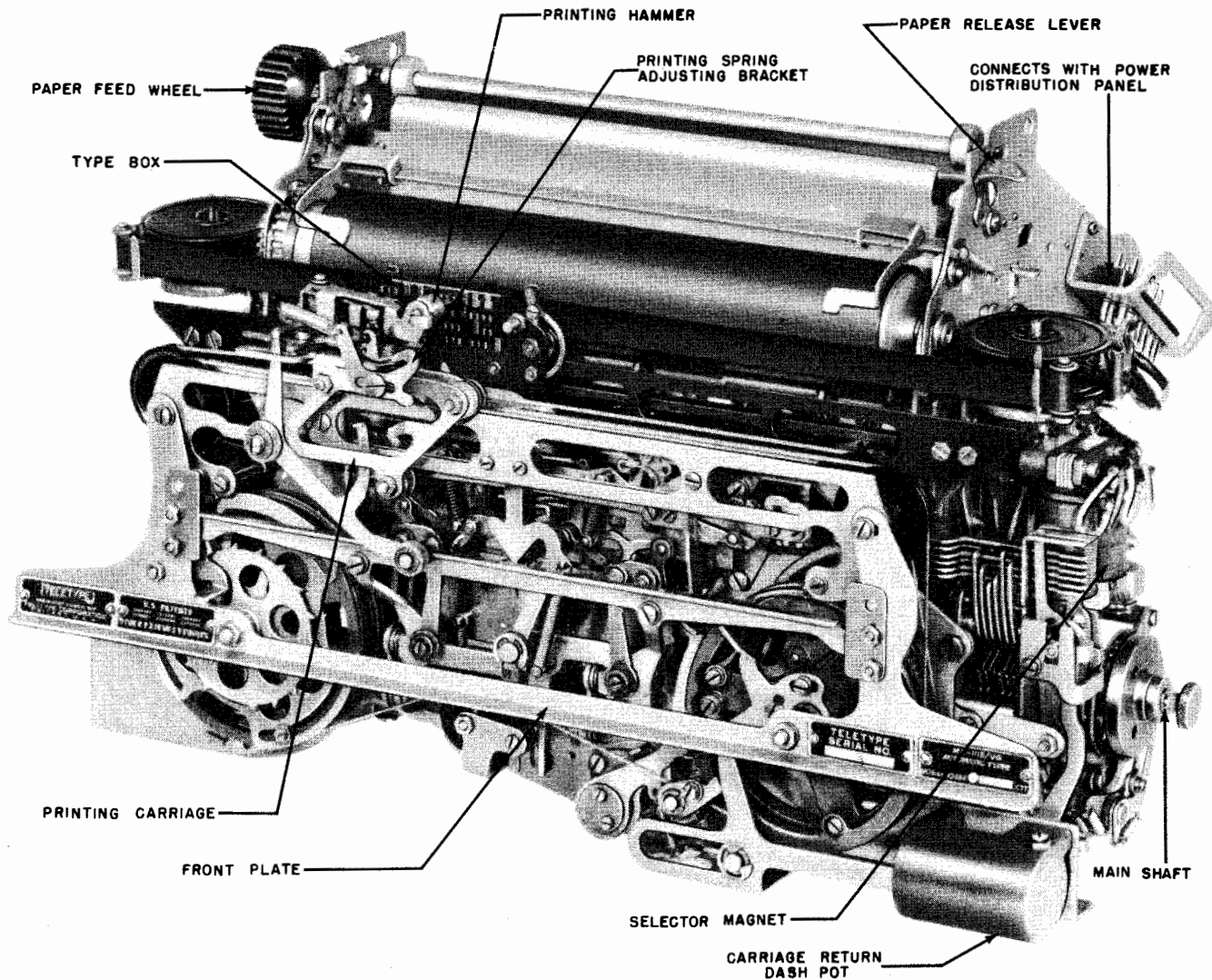


Figure 1-4. Automatic Typewriter MX-1115/UG, Front View

on the underside of the motor, houses the governor resistor and capacitor, as well as a power leads electrical noise suppressor. A number of screened cutouts are provided in the motor shield housing through which air may circulate and the target may be viewed. A threaded plug in the housing may be removed to permit entry of a screwdriver when making speed adjustments.

*d.* CABINETS.

(1) GENERAL.—Cabinets are of two types; the CY-870/UG for deck mounting and the CY-871/UG for bulkhead shelf mounting. They are of sheet metal construction and are finished internally and externally in baked enamel. The CY-870/UG Cabinet (figure 1-1) is approximately 40 inches high, 20½ inches wide, and 18½ inches deep. The upper portion forms a compartment for housing the mechanical units and Power Distribution Panel. A shelf located in the lower section

may be used to support a Rectifier (not furnished as part of these teletypewriters). The CY-871/UG Cabinet (figure 1-1) has no lower section but is otherwise practically identical with the CY-870/UG and has a height of 16 inches. The top of each Cabinet forms a dome that is hinged at the rear. The dome is unlatched by a push button and is counterbalanced by mechanism that aids in raising it and supports it in the open position. A copyholder is attached to the front of the dome. A window through which the message may be read while being printed is located in the upper portion of the dome. The window is positioned horizontally to avoid reflection from ceiling lights. A hinged lid in the dome is unlatched by a push button to permit access to the printed copy. The copy is illuminated by incandescent lamps located under the dome. Rubber sealing strips are applied to the edges of both the dome and the lid for

silencing effects. The cradles listed below as accessories include a tilting arrangement which permits the assembled units to be tilted forward and supported, when the dome is open, and thereby permit maximum accessibility to the mechanism while servicing (figure 1-11). Terminal boards for power and signal line connections are located on the inner rear wall (figure 1-12). The Power Distribution Panel is placed to the rear of the Keyboard. Its power switch is controllable from a switch level at the front of the Cabinet.

(2) ACCESSORIES.—Accessories to the cabinets consist of the following:

(a) A signal bell to make signals audible that are transmitted for supervisory purposes. This is incorporated in both the CY-870/UG and CY-871/UG Cabinets.

(b) A rubber mounted cradle assembly used only in the shelf mounting CY-871/UG Cabinet.

(c) A steel mounted cradle assembly used only in the deck mounting CY-870/UG Cabinet.





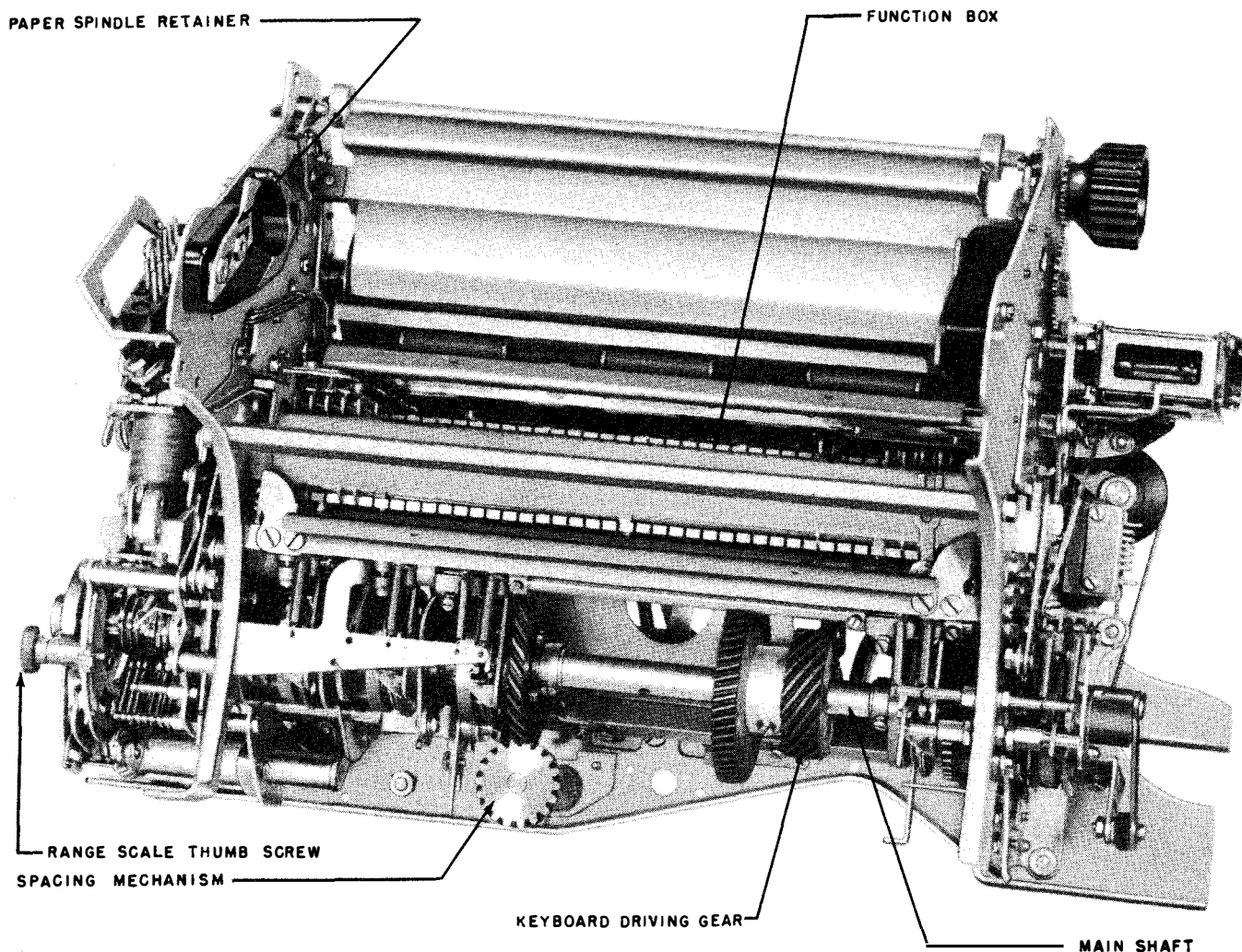


Figure 1-5. Automatic Typewriter MX-1115/UG, Rear View

(d) Shock mounts for mounting the CY-870/UG Cabinet to the deck.

(e) Stop arm assemblies for supporting the dome and copy door in their open positions where the CY-870/UG and CY-871/UG Cabinets are subject to tilting.

(f) A metal panel for reinforcing the lower section of the deck mounting CY-870/UG Cabinet.

(g) A six volt copy light assembly which is used in both the CY-870/UG and CY-871/UG Cabinets.

(h) A transformer assembly to supply six volts to all lamps. This is incorporated in both the CY-870/UG and CY-871/UG Cabinets.

(i) A six volt margin indicator lamp assembly used in both the CY-870/UG and CY-871/UG Cabinets.

(j) Two electrical noise suppressor assemblies which minimize electromagnetic radiation from the

power and signal lines external to the CY-870/UG and CY-871/UG Cabinets.

e. POWER DISTRIBUTION PANEL SB-154/UG. (See figure 1-13.)—The Power Distribution Panel is located in the upper compartment of the Cabinet. It incorporates motor control circuit elements, receptacles, fuses, switches, etc., which are associated with the power and signal line circuits.

#### 4. REFERENCE DATA.

a. NOMENCLATURE.—Teletypewriters TT-47/UG, TT-48/UG, TT-69/UG and TT-70/UG.

b. CONTRACT DATA.—NObsr-42434, dated 28 June 1948, NObsr-49182, dated 14 June 1950, NObsr-52088, dated 4 December 1950, NObsr-52089, dated 1 December 1950.

c. CONTRACTOR.—Teletype Corporation, Chicago 14, Illinois.

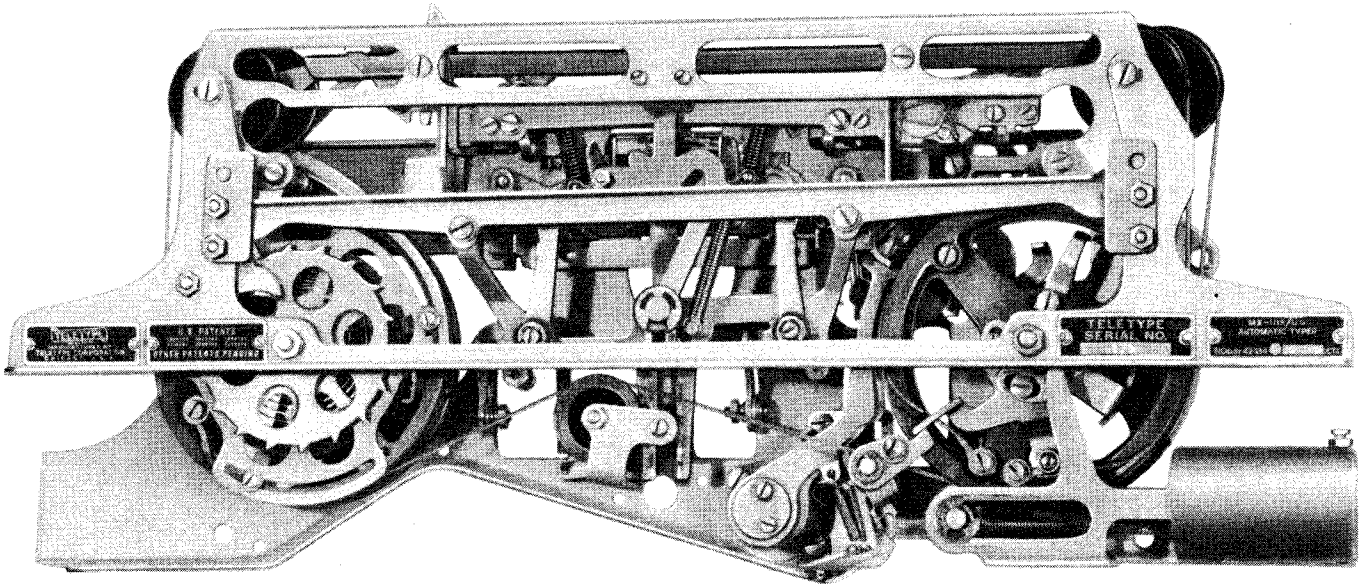


Figure 1-6. Automatic Typer Front Plate

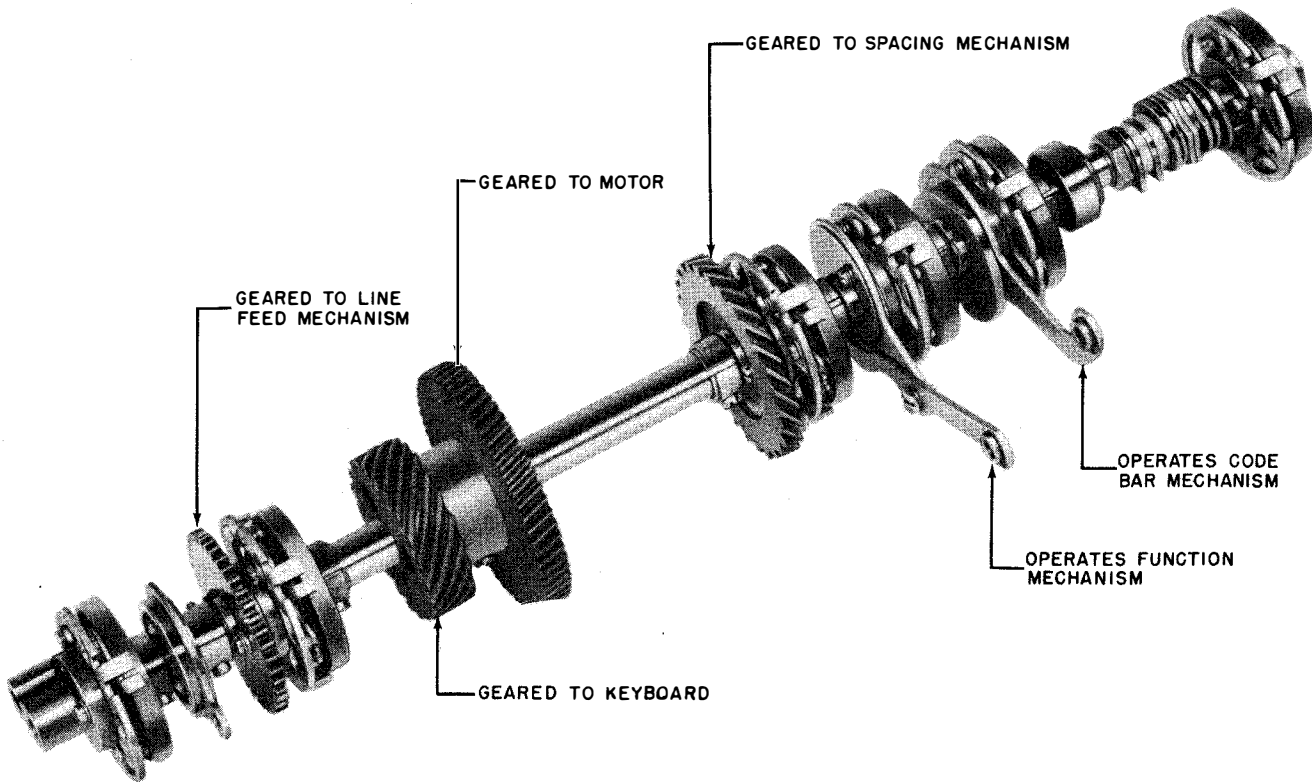


Figure 1-7. Automatic Typer Main Shaft

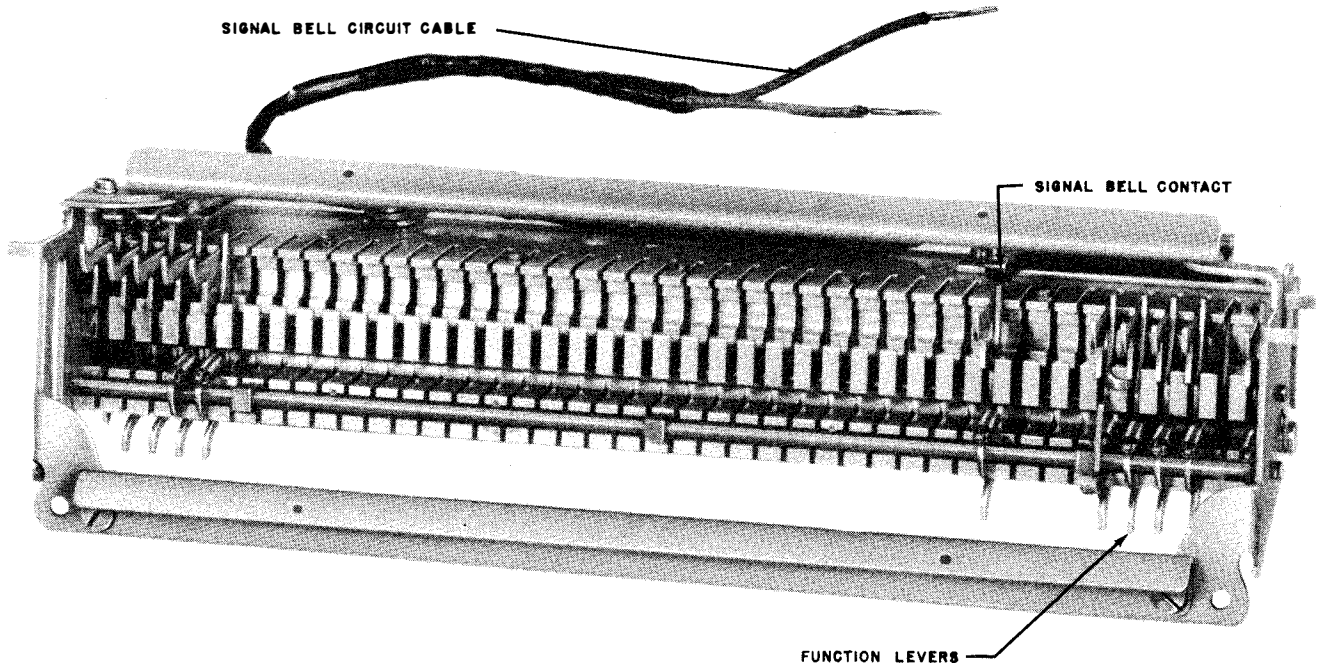


Figure 1-8. Automatic Typewriter Function Box

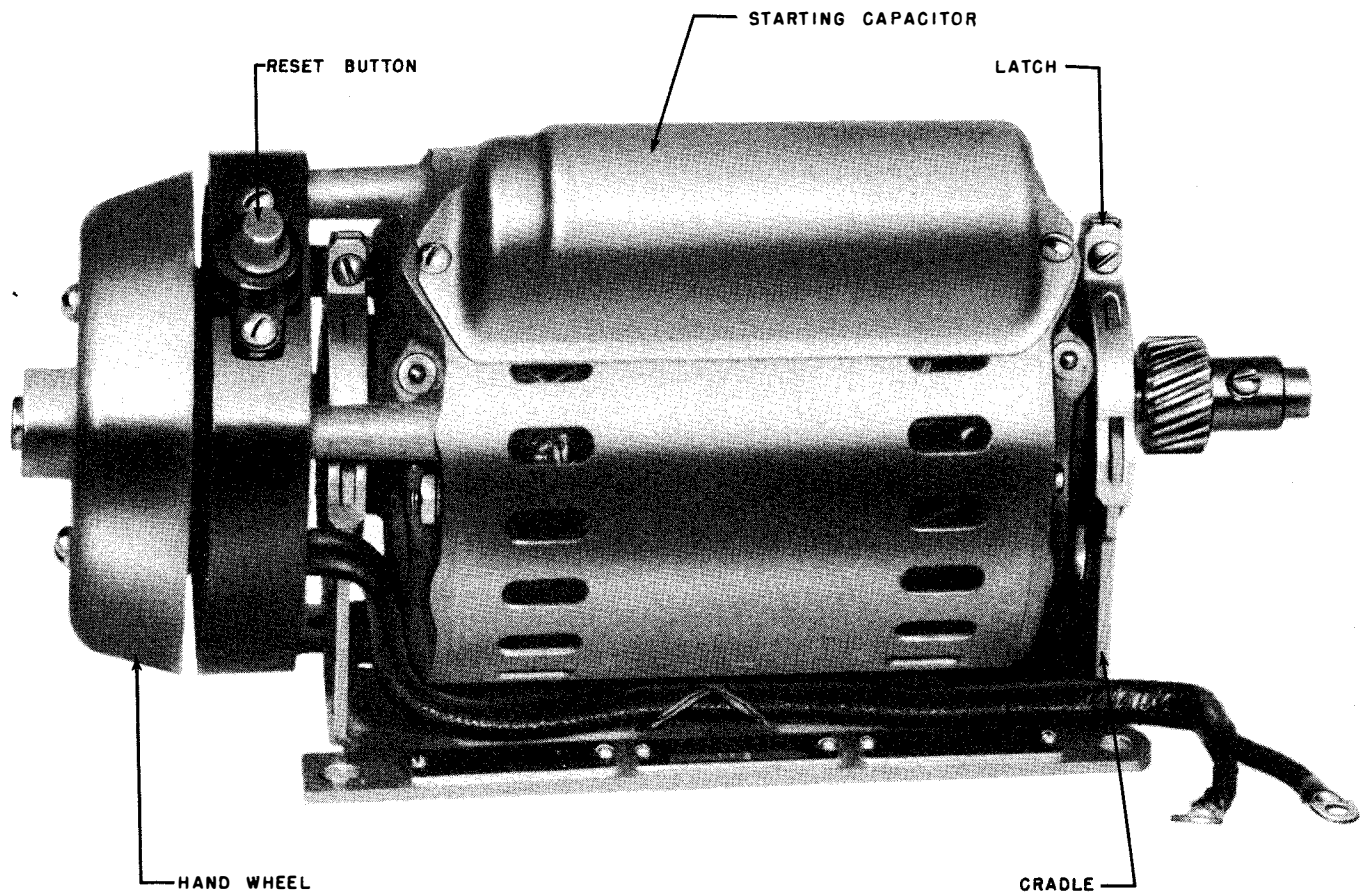


Figure 1-9. AC Motor PD-17/U, Synchronous

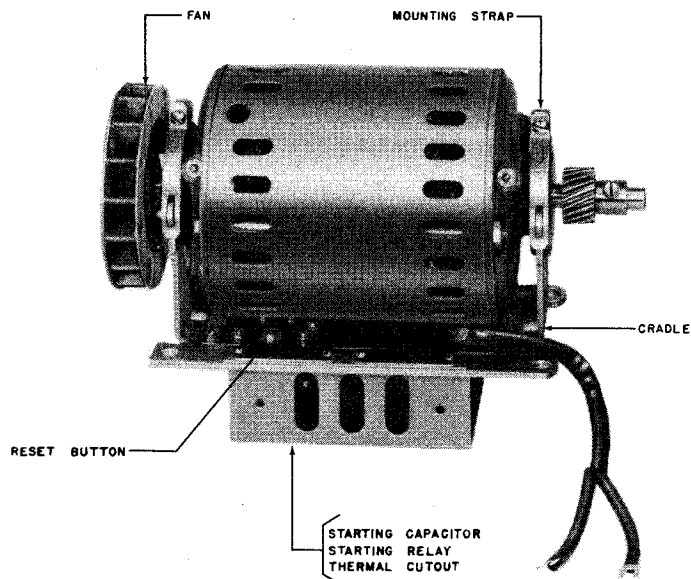


Figure 1-9A. AC Motor PD-17A/U, Synchronous

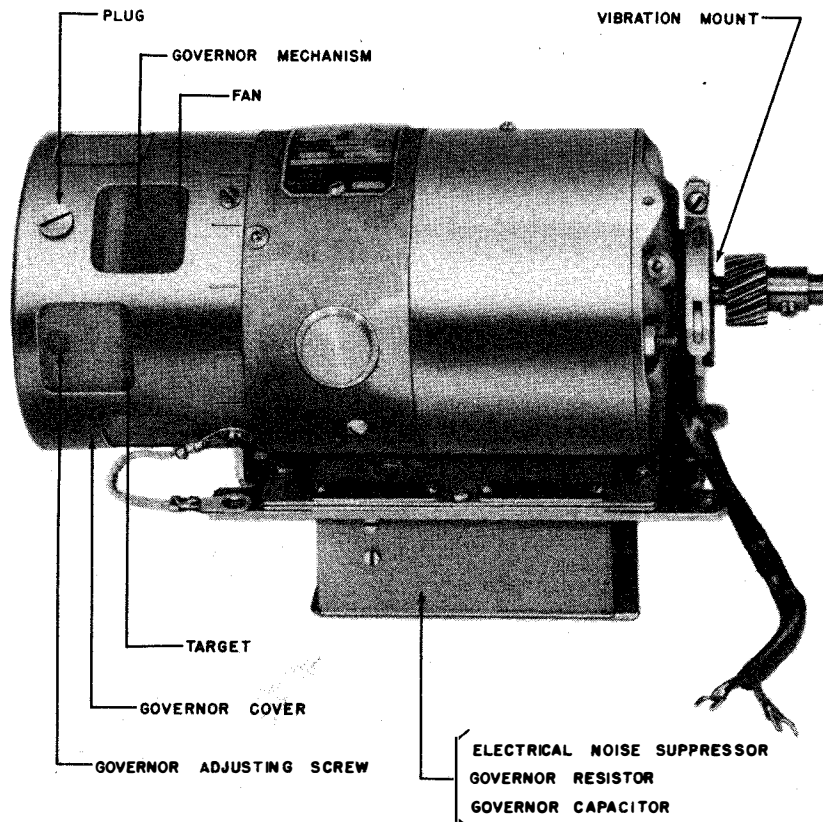


Figure 1-10. AC Motor PD-18/U, Governed

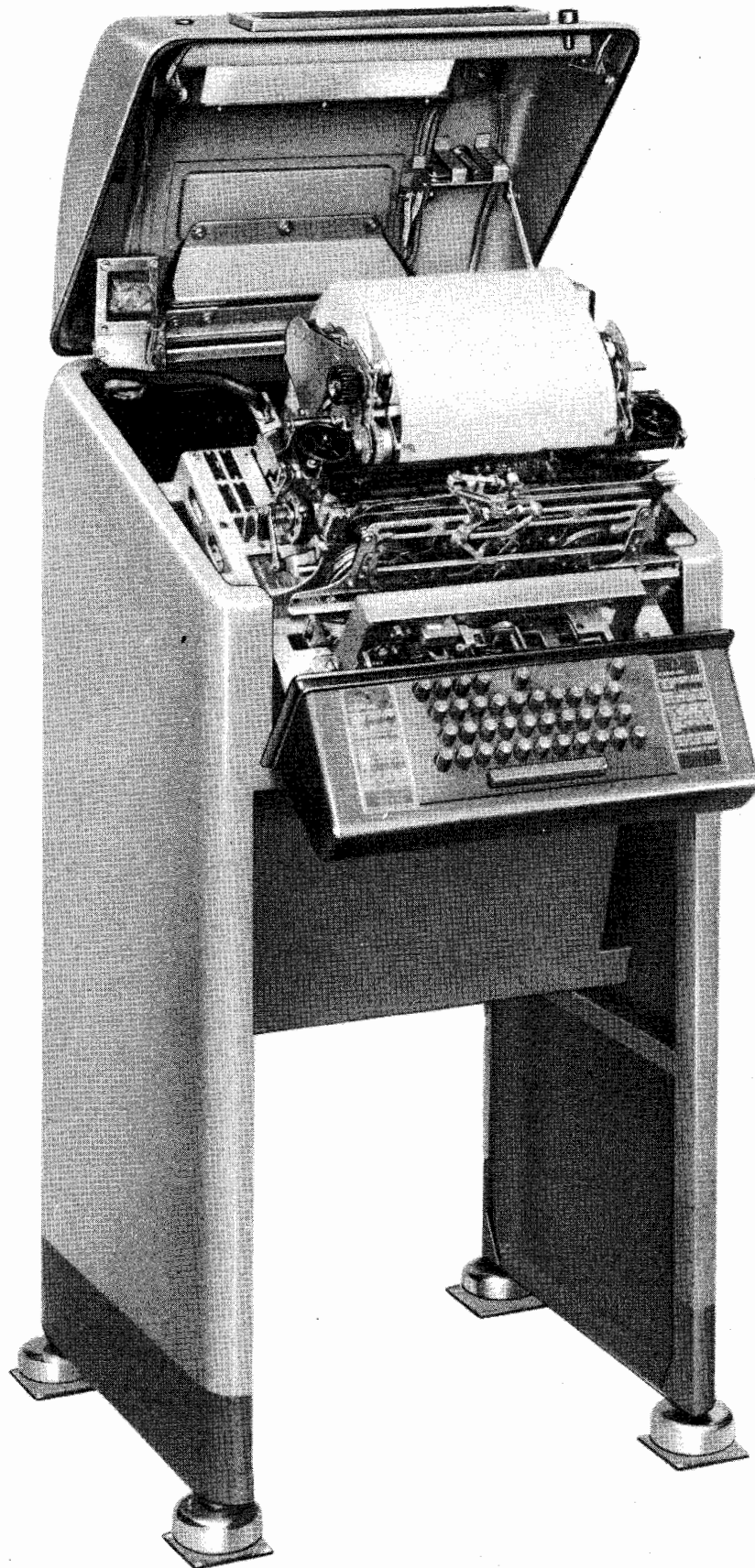


Figure 1-11. Tilting Arrangement

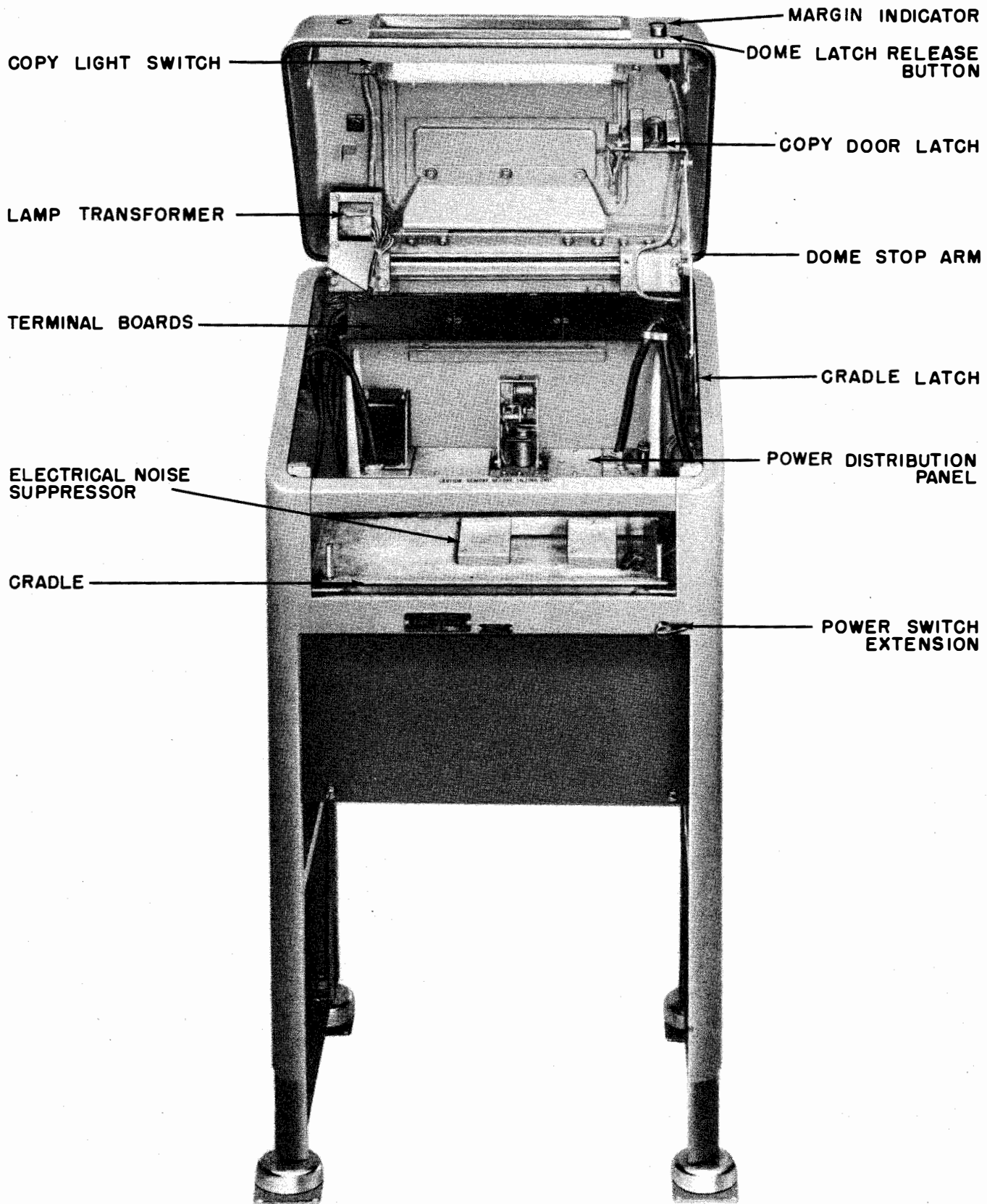


Figure 1-12. Cabinet CY-870/UG, With Power Distribution Panel

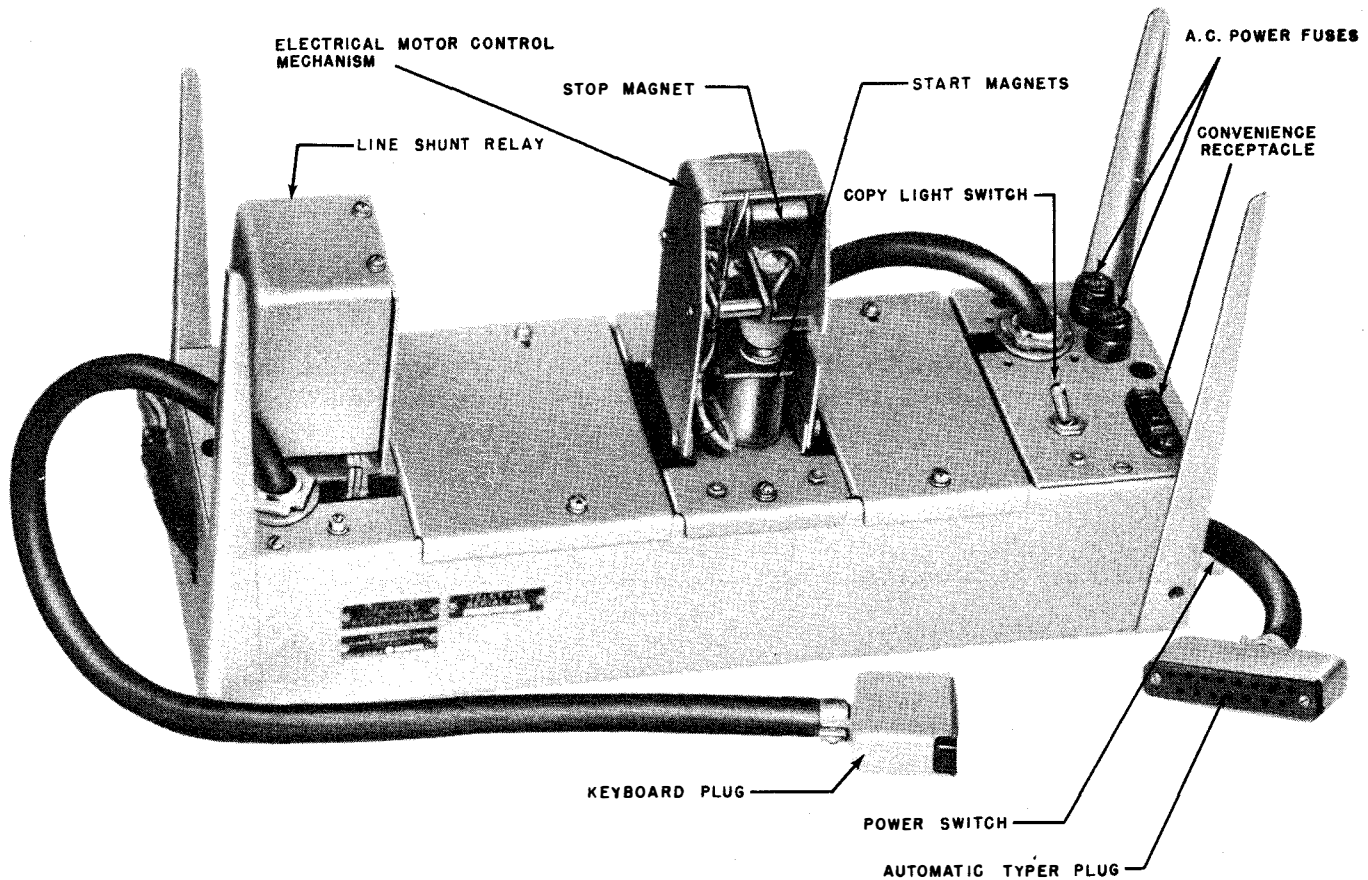


Figure 1-13. Power Distribution Panel SB-154/UG

d. COGNIZANT NAVAL INSPECTOR.—Inspector of Naval Material, Chicago 6, Illinois.

e. NUMBER OF PACKAGES INVOLVED IN COMPLETE SHIPMENT OF EQUIPMENT (INCLUDING EQUIPMENT SPARES) ..... 1 Box

f. TOTAL CUBICAL CONTENTS OF EQUIPMENT (INCLUDING EQUIPMENT SPARES).

Teletypewriters TT-47/UG or TT-48/UG.  
 Crated ..... 24.09 cu. ft.  
 Uncrated ..... 12.52 cu. ft.

Teletypewriters TT-69/UG or TT-70/UG.  
 Crated ..... 18.88 cu. ft.  
 Uncrated ..... 7.36 cu. ft.

g. TOTAL WEIGHT OF EQUIPMENT (INCLUDING EQUIPMENT SPARES).

Teletypewriters TT-47/UG or TT-48/UG.  
 Crated ..... 315 lbs.  
 Uncrated ..... 130 lbs.

Teletypewriters TT-69/UG or TT-70/UG.  
 Crated ..... 250 lbs.  
 Uncrated ..... 119 lbs.

b. ELECTRICAL CHARACTERISTICS.

(1) The SIGNALING FREQUENCY of the telegraph output signal is in maximum dot cycles (one cycle is one current impulse followed by one no-current impulse) per second:

Speed  
 60 words per minute — 22.8 cycles  
 75 words per minute — 28.5 cycles  
 100 words per minute — 37.1 cycles

(2) The FREQUENCY CONTROL depends on the use of either a synchronous motor or a governed motor.

(3) The OUTPUT TELEGRAPH SIGNAL must be on-off direct current nominally 0.060 ampere from an external source of either positive or negative polarity or from a 115 volt source at a rectifier in the Cabinet.

(4) The INPUT TELEGRAPH SIGNAL applied to the selector magnet must be on-off direct current, nominally 0.060 ampere from an external source of either positive or negative polarity, or from a 115 volt source at a rectifier in the Cabinet. Additional facilities are provided for operating from either source at 0.020 ampere.

(5) POWER SUPPLY REQUIREMENTS.

- (a) AC MOTORS (SYNCHRONOUS)  
PD-17/U and PD-17A/U.
1. Input voltage: 115 volts  $\pm$ 10 per cent a-c.
  2. Phase: Single phase.
  3. Frequency: 60 cycle  $\pm$ 0.5 cycle.
  4. Input current:  
Starting ..... 9 amps.  
Running ..... 1.85 amps.
  5. Power factor ..... 0.30
  6. Wattage ..... 65 watts
  7. Heat Dissipation ..... 50 Watts
- (b) AC MOTOR (GOVERNED) PD-18/U.
1. Input voltage: 115 volts  $\pm$ 10 per cent a-c.

2. Phase: Single phase.
3. Frequency: 50 to 60 cycles.
4. Input current:  
Starting ..... 1.75 amps.  
Running ..... 1 amp.
5. Power factor ..... 0.83
6. Wattage: ..... 95 watts
7. Heat Dissipation ..... 75 watts

- (c) PERMISSIBLE TEMPERATURES.
1. Ambient:  $-20^{\circ}$  C. ( $-40^{\circ}$  F.) to  $+50^{\circ}$  C. ( $+122^{\circ}$  F.)
  2. Temperature rise: Not in excess of  $+40^{\circ}$  C. ( $+104^{\circ}$  F.) above ambient.

TABLE 1-1. EQUIPMENT SUPPLIED

QUANTITY PER EQUIPMENT	NAME OF UNIT	NAVY TYPE DESIGNATION	OVER-ALL DIMENSIONS IN INCHES			VOLUME CU. FT.	WEIGHT POUNDS
			HEIGHT	WIDTH	DEPTH		
1	TELETYPEWRITER CONSISTING OF: CABINET AC MOTOR POWER DISTRIBUTION PANEL KEYBOARD AUTOMATIC TYPER SET OF GEARS (151060) EQUIPMENT SPARES (151681)	TT-47/UG	39½	20½	18¼	8.55	81
1		CY-870/UG					
1		PD-17/U					
1		SB-154/UG					
1		MX-1114/UG					
1		MX-1115/UG					
1		EQUIPMENT SPARES (151681)					
			TOTAL			12.52	129
1	TELETYPEWRITER CONSISTING OF: CABINET AC MOTOR POWER DISTRIBUTION PANEL KEYBOARD AUTOMATIC TYPER SET OF GEARS (151060) EQUIPMENT SPARES (151682)	TT-48/UG	39½	20½	18¼	8.55	81
1		CY-870/UG					
1		PD-18/U					
1		SB-154/UG					
1		MX-1114/UG					
1		MX-1115/UG					
1		EQUIPMENT SPARES (151682)					
			TOTAL			12.55	130
1	TELETYPEWRITER CONSISTING OF: CABINET AC MOTOR POWER DISTRIBUTION PANEL KEYBOARD AUTOMATIC TYPER SET OF GEARS (151060) EQUIPMENT SPARES (151681)	TT-69/UG	15½	20½	18¼	3.36	70
1		CY-871/UG					
1		PD-17/U					
1		SB-154/UG					
1		MX-1114/UG					
1		MX-1115/UG					
1		EQUIPMENT SPARES (151681)					
			TOTAL			7.33	118
1	TELETYPEWRITER CONSISTING OF: CABINET AC MOTOR POWER DISTRIBUTION PANEL KEYBOARD AUTOMATIC TYPER SET OF GEARS (151060) EQUIPMENT SPARES (151682)	TT-70/UG	15½	20½	18¼	3.36	70
1		CY-871/UG					
1		PD-18/U					
1		SB-154/UG					
1		MX-1114/UG					
1		MX-1115/UG					
1		EQUIPMENT SPARES (151682)					
			TOTAL			7.36	119



TABLE 1-2. SHIPPING DATA

SHIPPING BOX NO.	CONTENTS		OVER-ALL DIMENSIONS IN INCHES			VOLUME CU. FT.	WEIGHT POUNDS
	NAME	DESIGNATION	HEIGHT	WIDTH	DEPTH		
1	TELETYPEWRITER CONSISTING OF: CABINET AC MOTOR  POWER DISTRIBUTION PANEL KEYBOARD AUTOMATIC TYPER SET OF GEARS (151060) EQUIPMENT SPARES (151681)	TT-47/UG CY-870/UG PD-17/U or PD-17A/U SB-154/UG MX-1114/UG MX-1115/UG	45 <sup>3</sup> / <sub>4</sub>	22 <sup>3</sup> / <sub>4</sub>	40	24.09	314
1	TELETYPEWRITER CONSISTING OF: CABINET AC MOTOR POWER DISTRIBUTION PANEL KEYBOARD AUTOMATIC TYPER SET OF GEARS (151060) EQUIPMENT SPARES (151862)	TT-48/UG CY-870/UG PD-18/UG SB-154/UG MX-1114/UG MX-1115/UG	45 <sup>3</sup> / <sub>4</sub>	22 <sup>3</sup> / <sub>4</sub>	40	24.09	315
1	TELETYPEWRITER CONSISTING OF: CABINET AC MOTOR  POWER DISTRIBUTION PANEL KEYBOARD AUTOMATIC TYPER SET OF GEARS (151060) EQUIPMENT SPARES (151681)	TT-69/UG CY-871/UG PD-17/U or PD-17A/U SB-154/UG MX-1114/UG MX-1115/UG	45	25	29	18.88	249
1	TELETYPEWRITER CONSISTING OF: CABINET AC MOTOR POWER DISTRIBUTION PANEL KEYBOARD AUTOMATIC TYPER SET OF GEARS (151060) EQUIPMENT SPARES (151862)	TT-70/UG CY-871/UG PD-18/U SB-154/UG MX-1114/UG MX-1115/UG	45	25	29	18.88	250

TABLE 1-3. EQUIPMENT REQUIRED BUT NOT SUPPLIED

QUANTITY PER EQUIPMENT	NAME OF UNIT
1	Set of Tools as listed in Table 7-2.

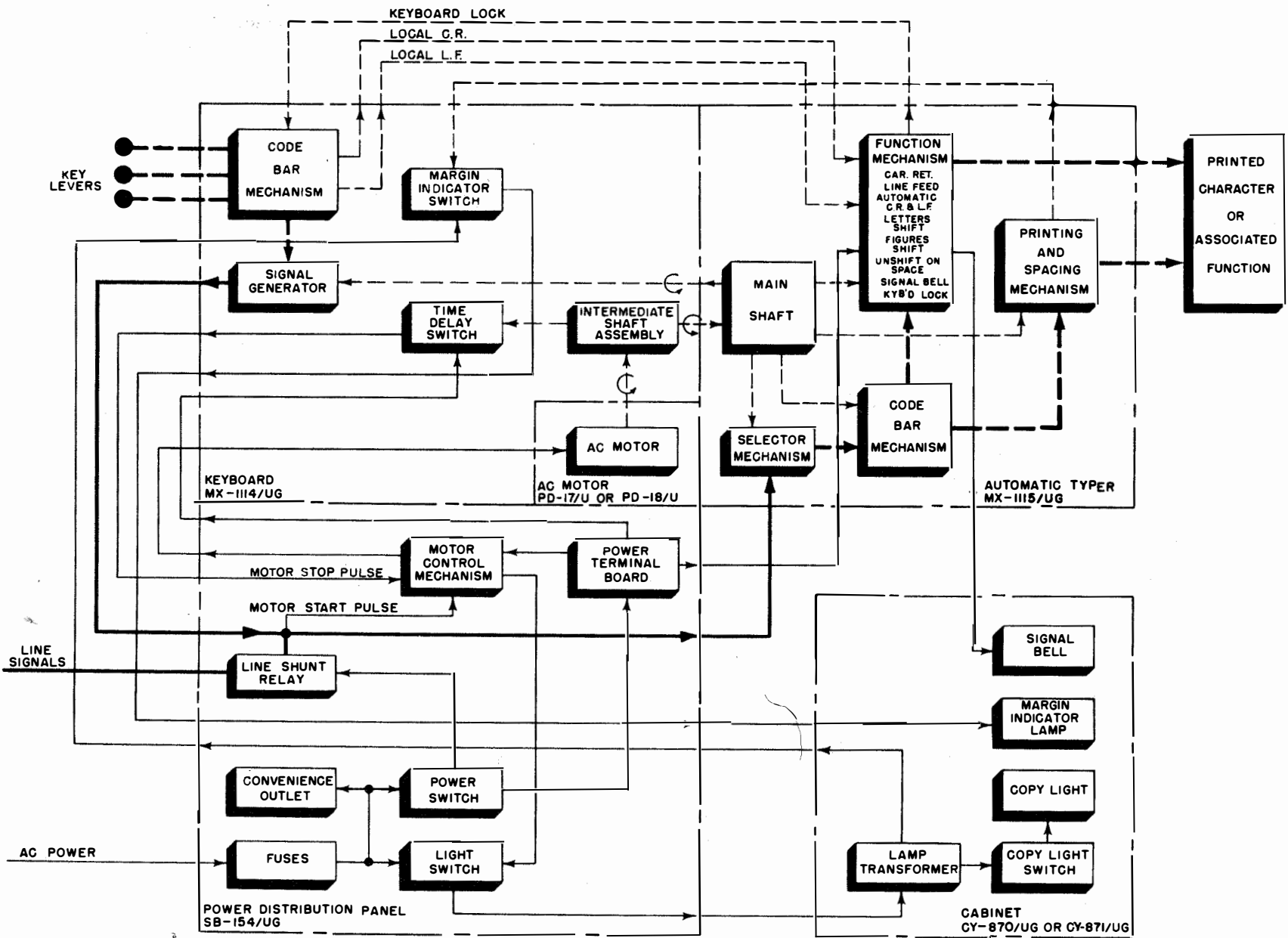


Figure 2-1. Teletypewriters, TT-47/UG, TT-48/UG, TT-69/UG & TT-70/UG, Functional Block Diagram

## SECTION 2 THEORY OF OPERATION

### 1. GENERAL.

a. This section covers the operating principles and circuit descriptions of Teletypewriters TT-47/UG, TT-48/UG, TT-69/UG, and TT-70/UG. Each equipment serves as a sending and receiving page-type printing telegraph set when connected to the terminal facilities of a wire or radio telegraph circuit, and will operate on signal line current of either 20 or 60 milliamperes without a line relay. The signals transmitted and received on the local loop by these Teletypewriters are of the neutral type (open and close DC)—7.42 unit start-stop transmission pattern with a speed of 368 operations per minute (opm). The equipments are adaptable to speeds of 460 or 600 opm by gearing changes. The main circuit may carry any standard type of start-stop telegraph signals and may be keyed by any conventional method. Synchronous motors require a power supply of 115 volts (plus or minus 10 per cent) 60 cycle, single phase alternating current. To avoid loss in receiving margin with this type of motor, the frequency regulation must be within plus or minus one-half cycle. Governed motors require a like power supply except that the frequency may be from 50 to 60 cycles.

b. The general electrical and mechanical relationships of the units which make up the Teletypewriters are shown in figure 2-1, a functional block diagram.

### 2. SIGNALING CODE.

a. The signaling code is an electrical code of current

and no-current intervals. Impulses which energize the selector magnets are known as marking impulses and those which do not are known as spacing.

b. This five unit code is composed of five selecting intervals which may be either marking (current) or spacing (no-current) according to the code sequence of the character to be transmitted. Each group of five selecting intervals is preceded by a start interval (no-current) and is followed by a stop impulse (current) both of which are used to maintain synchronism between the transmitting and receiving apparatus. Figure 2-2 shows graphically, the code used.

### 3. KEYBOARD MX-1114/UG.

a. The Keyboard consists essentially of an intermediate shaft assembly, a code bar mechanism, and a signal generator. It also contains the time delay and margin indicator switch mechanisms, and provides mounting facilities for the Automatic Typer MX-1115/UG and for either the PD-17/U or PD-18/U AC Motor. At the time the Keyboard is installed in its Cabinet, a connector P-1101 on the end of a rubber covered cable which emanates from the Power Distribution Panel SB-154/UG (figure 1-13), is plugged into a receptacle J-101 mounted on the top left rear corner of the Keyboard (figures 1-2 and 1-11). See figure 2-3 for schematic wiring. In operation, the motor drives the intermediate shaft assembly which furnishes motive power to the automatic typer main shaft (figures 1-5 and 1-7). This, in turn,

FIGURES	-	?	:	\$	3	!	&	£	8	'	(	)	.	,	9	∅	1	4	BELL	5	7	;	2	/	6	"	BLANK	LETTERS	FIGURES	SPACE	C.R.	L.F.
LETTERS	A	B	C	D	E	F	G	H	I	J	K	L	M	N	O	P	Q	R	S	T	U	V	W	X	Y	Z	BLANK	LETTERS	FIGURES	SPACE	C.R.	L.F.
NUMBERS INDICATE MARKING IMPULSES	1	1		1	1	1				1	1					1		1		1		1	1	1	1		1	1				
	2		2				2		2	2	2	2				2	2	2			2	2	2				2	2				2
	0	0	0	0	0	0	0	0	0	0	0	0	0	0	0	0	0	0	0	0	0	0	0	0	0	0	0	0	0	0	0	0
			3			3		3	3		3		3	3		3	3		3		3	3		3	3		3		3			
		4	4	4		4	4			4	4		4	4	4			4					4	4		4	4		4			
	5					5	5					5	5	5	5	5			5		5	5	5	5	5		5	5				

Figure 2-2. Signal Code

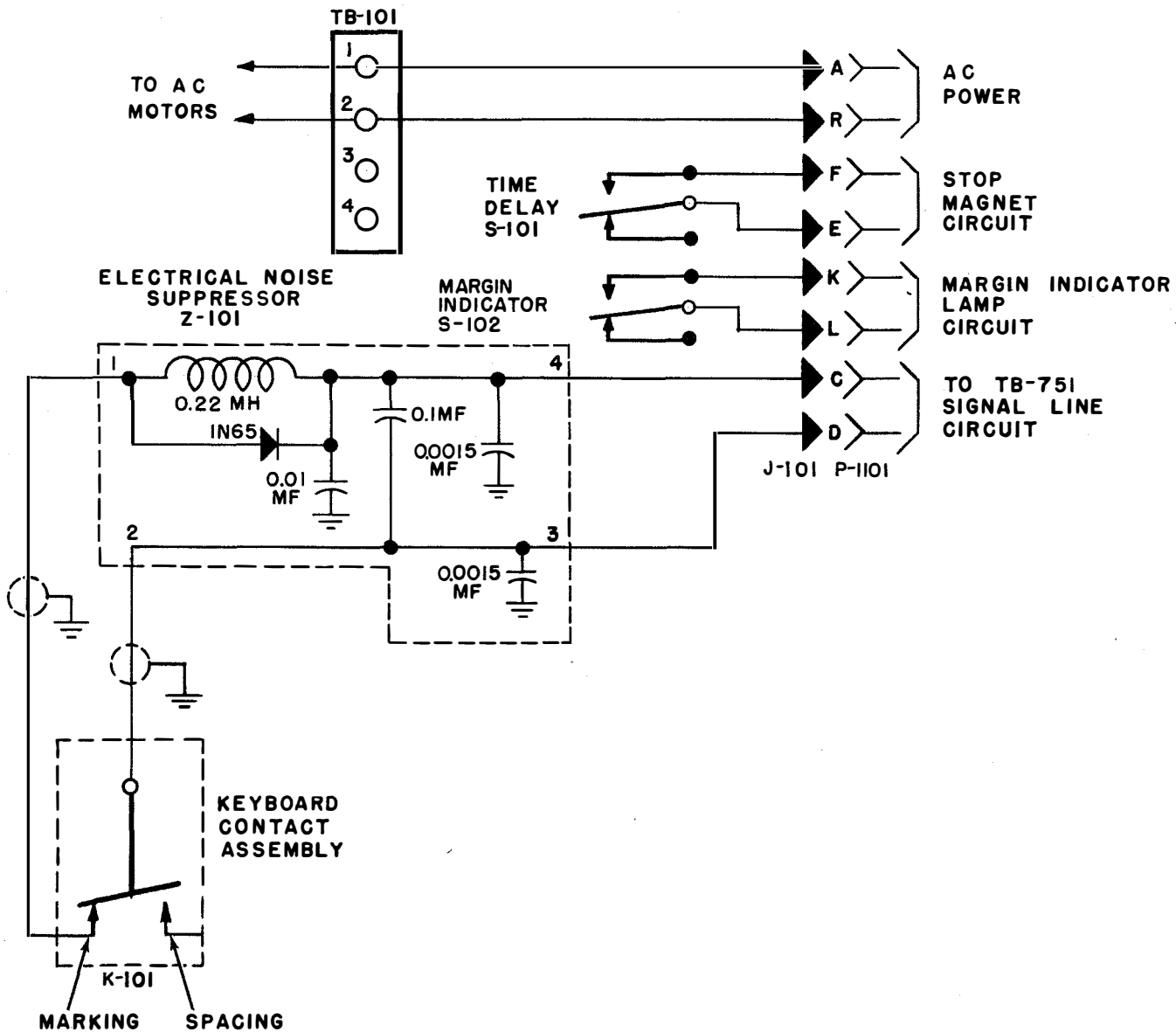


Figure 2-3. Keyboard MX-1114/UG, Schematic Wiring Diagram

drives the signal generator helical driven gear which is connected to the keyboard clutch drum by a sleeve. Thus, the keyboard clutch drum is caused to rotate continually while the motor is running. The transmitting cam-clutch assembly of the signal generator mechanism remains stationary except when motion is extended to it from the keyboard clutch drum. Engagement of the clutch is brought about by the operation of any key in the lower three rows (green), or the space bar, and a transmitting cycle is then initiated.

b. INTERMEDIATE SHAFT ASSEMBLY.—The intermediate shaft assembly, located in the rear central portion of the Keyboard (figure 1-2), mounts two helical gears and an eccentric cam. When the AC Motor

and the Automatic Typer are in place on the Keyboard, the intermediate shaft helical driven gear is engaged with and driven by the intermediate shaft helical driving gear on the motor. The main shaft helical driving gear on the intermediate shaft transfers this motive force to the automatic typer main shaft. The rotating eccentric cam on the intermediate shaft drives the eccentric follower pawl on the time delay mechanism so as to give it a reciprocating motion. The gear ratio between the intermediate shaft helical driving gear on the motor, and the helical driven gear on the intermediate shaft, determines the maximum speed (operations per minute) at which the equipment will operate. These gears are readily replaceable with gears which will furnish other operating speeds.

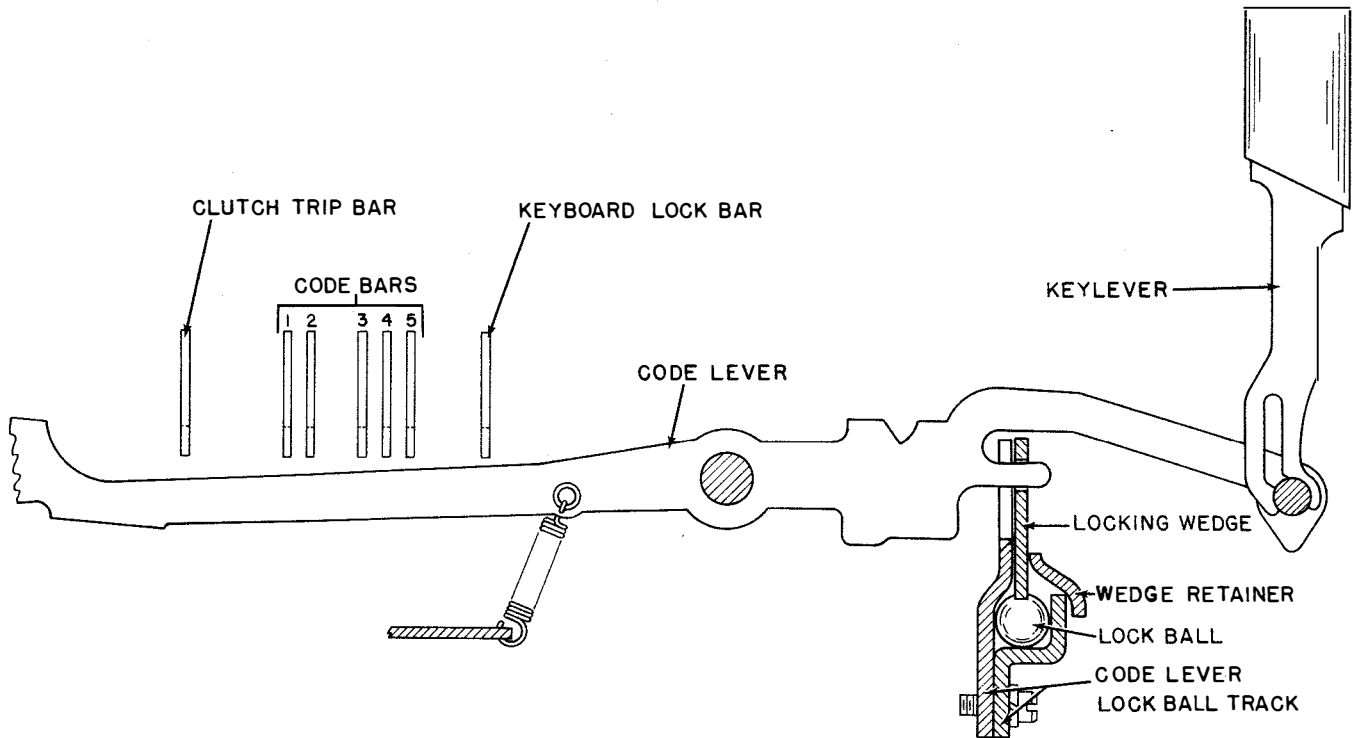


Figure 2-4. Code Bar Arrangement

c. CODE BAR MECHANISM.—The code bar mechanism is located in the front underside portion of the Keyboard. Each keylever in the lower three rows (green), and the space bar is connected to a code lever and each keylever in the upper row (red), is connected to a function lever. The code and function levers pivot about points near their midportions (figure 2-4). Located above the rear half of the code levers and running parallel with the front of the Keyboard are, from rear to front, the clutch trip bar, the numbers 1, 2, 3, 4, and 5 code bars, and the lock bar. The rear portion of each code or function lever normally is held downward by a spring so that the front end with its attached keylever is held upward. A locking wedge is mounted on the projection of the lower front portion of all code levers, the local line feed function lever, and the local carriage return function lever (figures 2-4 and 2-5). If one of these levers is operated, its locking wedge moves downward between the lock balls in the lock ball track, and crowds them together. This prevents any other lever with a locking wedge from being operated at the same time. With the keyboard shaft in its stop position, the clutch trip bar and the five code bars are held toward the left (front view), against the tension of their springs, by the latched-up code bar bail. When any green keylever or the space bar is depressed, the rear end of the associated code lever engages and lifts the

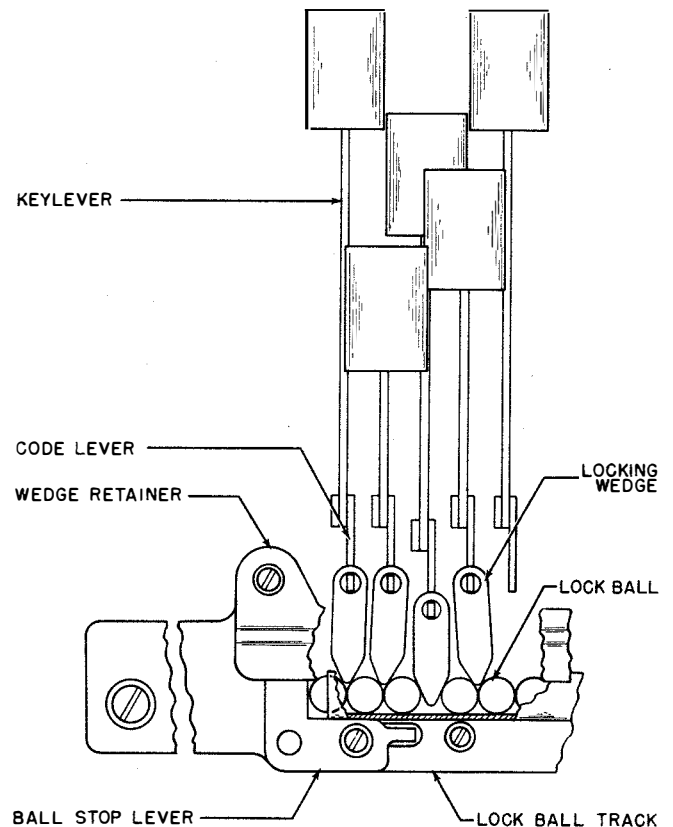


Figure 2-5. Keylever Lock Ball Mechanism

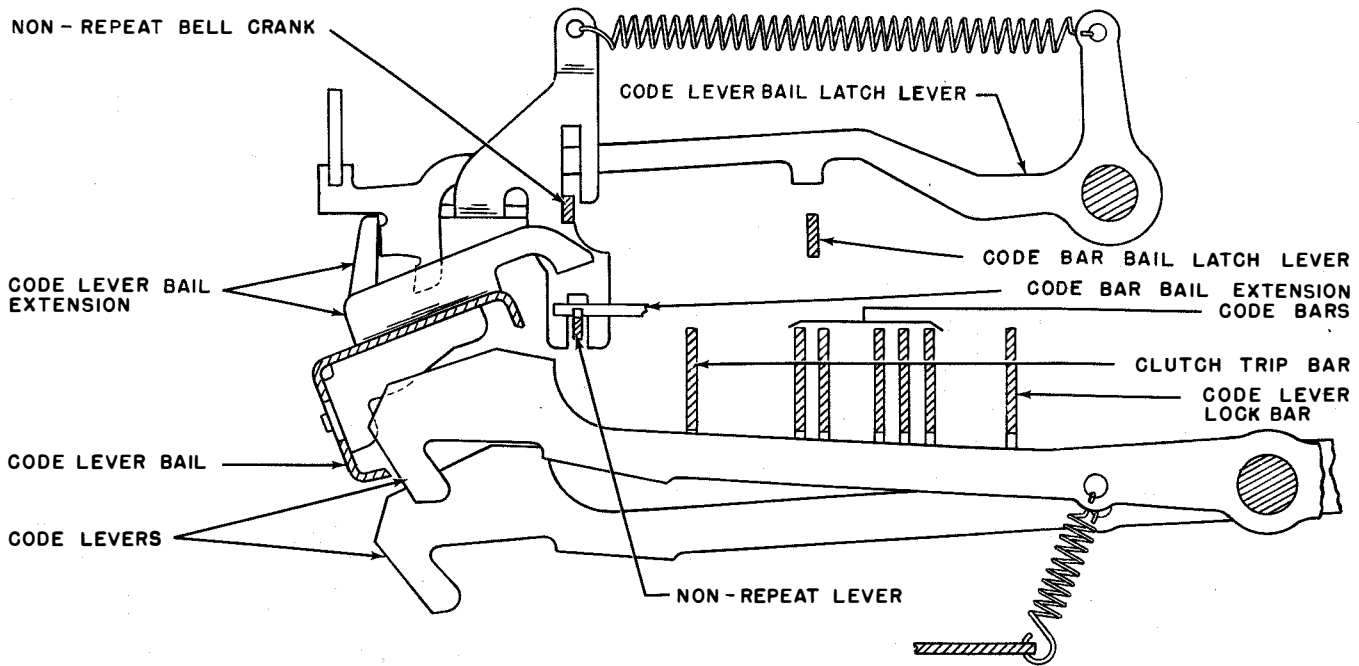


Figure 2-6. Keylever Mechanism, Selected Position

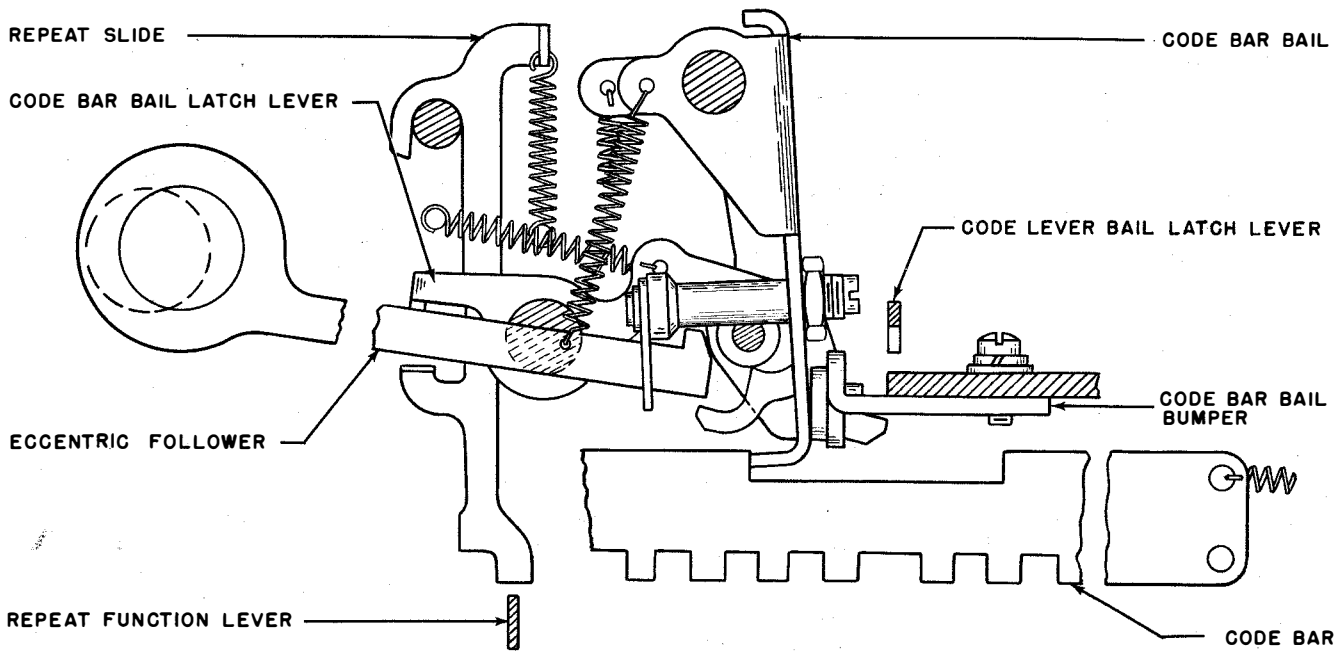


Figure 2-7. Code Bar Bail Mechanism, Released Position

front edge of the code lever bail (figure 2-6). An extension on the code lever bail disengages the code lever bail latch lever and permits it to drop. As the front edge of the code lever bail rises, the back edge rotates around the rear end of the operated code lever and

locks it in position. As the code lever bail latch lever drops, it depresses the code bar bail latch lever and releases the code bar bail (figure 2-7). Upon being freed, the code bar bail, the clutch trip bar, and the five code bars are pulled toward the right by their springs, until

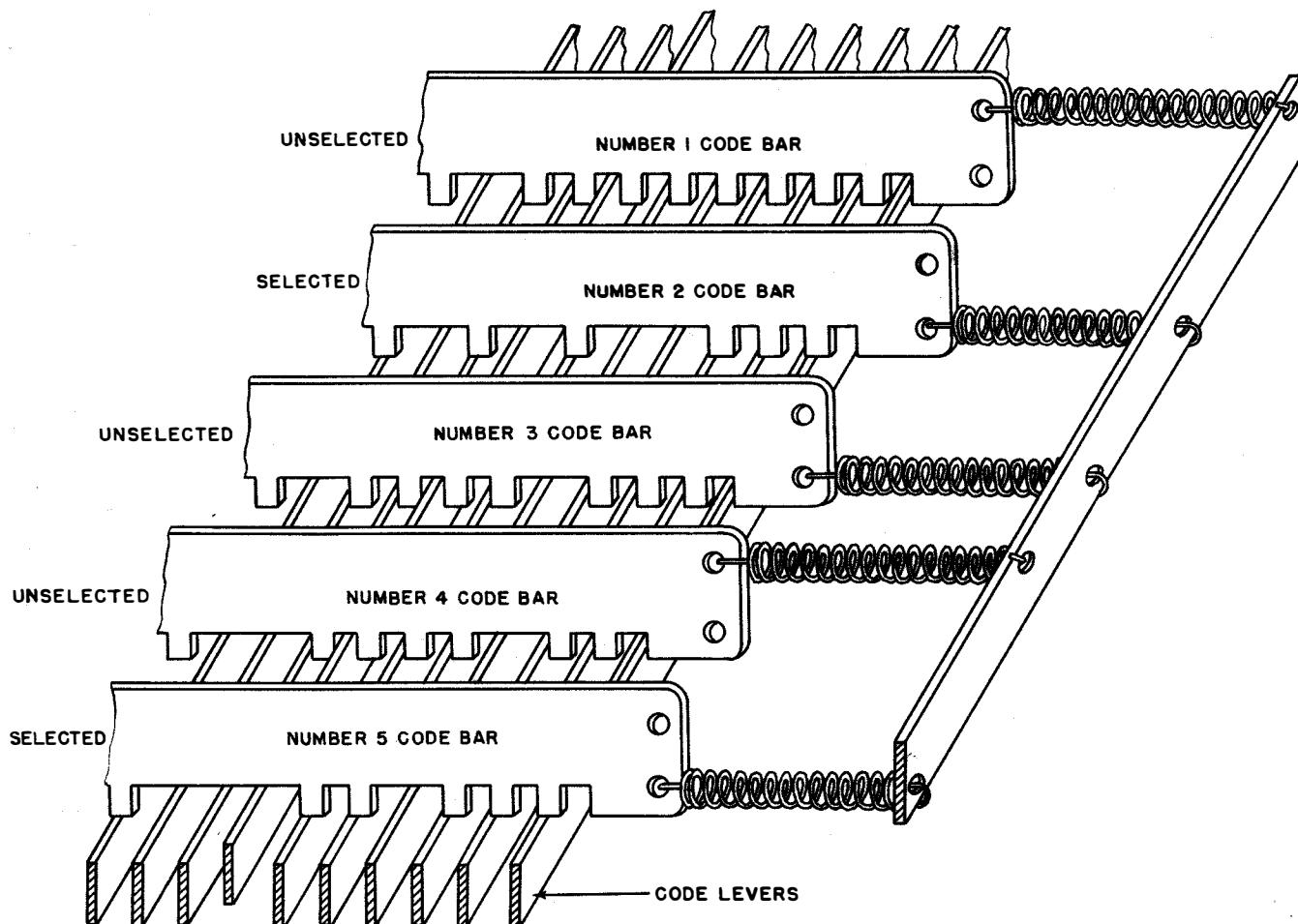


Figure 2-8. Code Bar Selection

the code bar bail strikes its bumper. As the five code bars shift, code projections on unselected code bars engage the operated code lever (figure 2-8). Code bars which are permitted to move to the extreme right become selected and carry with them their respective transfer levers. By means of the clutch trip bail and the clutch stop lever, the clutch trip bar releases the keyboard cam-clutch which rotates with the shaft. During the time in which the cam-clutch makes a revolution, an eccentric cam and its follower cause the code bar bail, the five code bars, and the clutch trip bar to be returned to their original positions (figures 2-9 and 2-10). As the code bar bail moves to the left, it carries with it the non-repeat lever (figure 2-11). This in turn rotates the non-repeat bell crank about its pivot point until it lifts the code lever bail latch lever out of engagement with the code lever bail extension (figure 2-6). While a spring then returns the code lever bail to its normal position, the code lever bail extension drops on the non-repeat lever to disengage it from the code bar bail. The spring then resets the non-repeat mechanism. As the

code bar bail returns to its normal position, it releases the operated code lever and its keylever. As the cam-clutch nears the end of its revolution, the throwout bail pawl drops into a notch on the cam disk. Next, the clutch throwout bail drops off the high point of its cam. Powered by a spring, it drives its pawl and the cam disk until the clutch shoe lever is stopped by the clutch stop lever and the clutch shoes are disengaged from the drum (figure 2-12). For detailed information on the operation of the clutch shoes, see paragraph 4.b.(3) of this section.

*d. SIGNAL GENERATOR MECHANISM.*—The signal generator mechanism is located on the top front part of the keyboard chassis. As was shown in paragraph 3.c., each of the five code bars operates its own transfer lever (figure 2-13). In addition to these five transfer levers, there are two others which are not associated with code bars and which are used to originate the start and stop pulses. The start pulse transfer lever (seventh from the rear and located next to the fifth pulse transfer lever) is permanently positioned so that

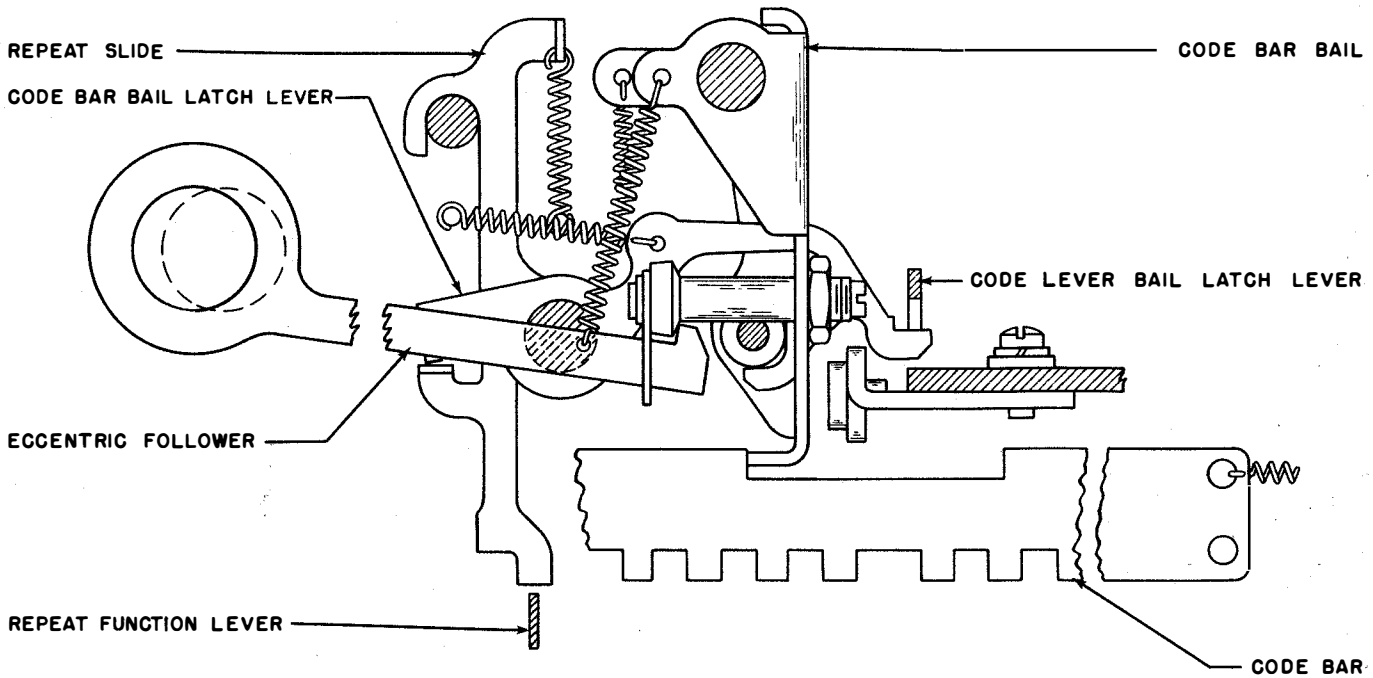


Figure 2-9. Code Bar Bail Mechanism, Reset Position

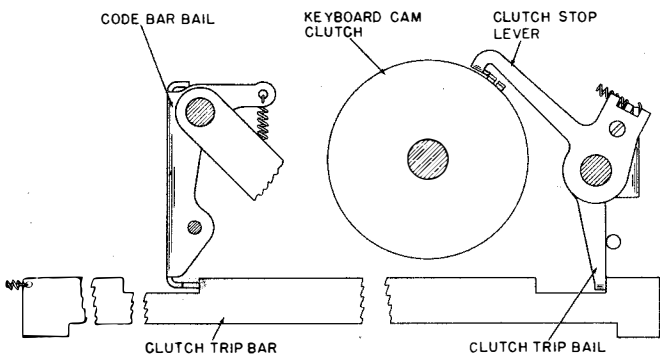


FIGURE 2-10. CLUTCH TRIP MECHANISM, VIEWED FROM REAR

Figure 2-10. Clutch Trip Mechanism,  
Viewed From Rear

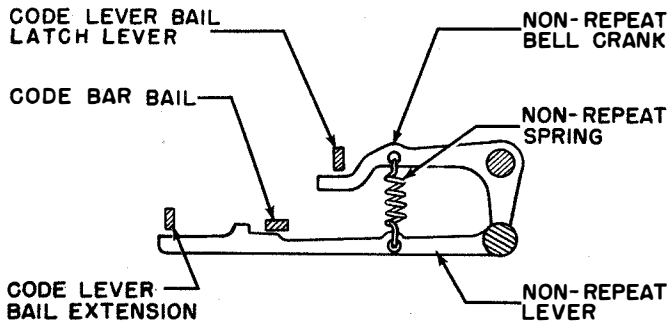


Figure 2-11. Non-Repeat Lever Mechanism

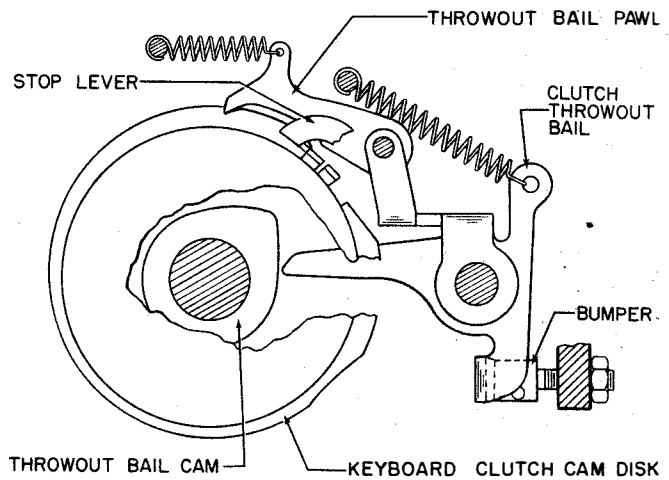


Figure 2-12. Keyboard Clutch Throwout Mechanism



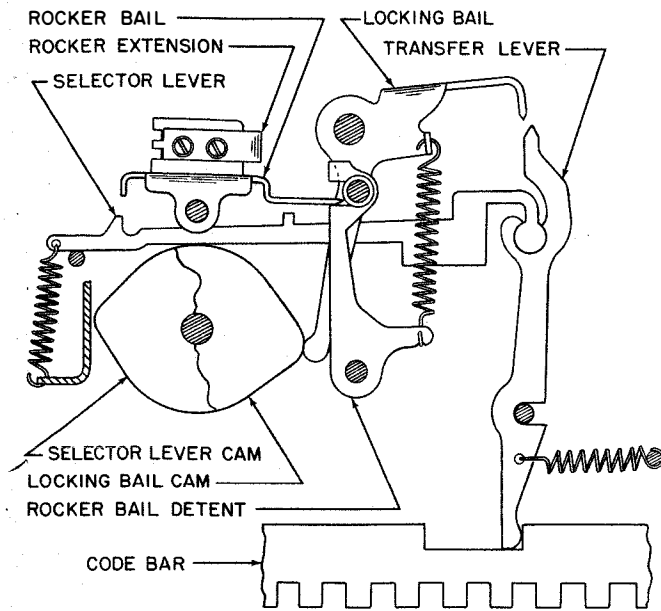


Figure 2-13. Signal Generator Mechanism, Front View

its upper end, and its associated selector lever are toward the left or selected position. The stop pulse transfer lever (third from rear and located between the second and third pulse transfer levers) is permanently positioned so that its upper end, and its associated selector lever are to the right or unselected position. When a code bar is unselected, the upper end of its transfer lever and its associated selector lever are positioned toward the right (figure 2-13). When a code bar is selected, the upper end of its transfer lever and its associated selector lever are positioned toward the left (figure 2-14). After the code bars have positioned their transfer levers and selector levers, the locking bail which is operated by a cam on the keyboard cam-clutch assembly drops downward between the lock projections on the upper ends of the transfer levers (figure 2-15). When the selected code bars are reset by the code bar bail, the upper ends of their transfer levers are held toward the left by the locking bail. The slotted bearings at their pivot points permit the transfer levers to shift to the left without disturbing the selection set up on the selector levers. Each of the seven selector levers is associated with a cam on the cam-clutch assembly. These cams push the levers upward briefly in the order: start, 1, 2, 3, 4, 5, and stop. A rocker bail is located above the selector levers and is actuated by them. A rocker bail detent holds the bail in either of the two positions it can assume. When a selector lever which is in the unselected position (toward the right) is pushed upward by its cam, it rotates the rocker bail clockwise (figure 2-13). When a selector lever which is in the selected position (toward the left) is pushed upward by its cam, it rotates the rocker bail counterclockwise (figure 2-15).

ORIGINAL

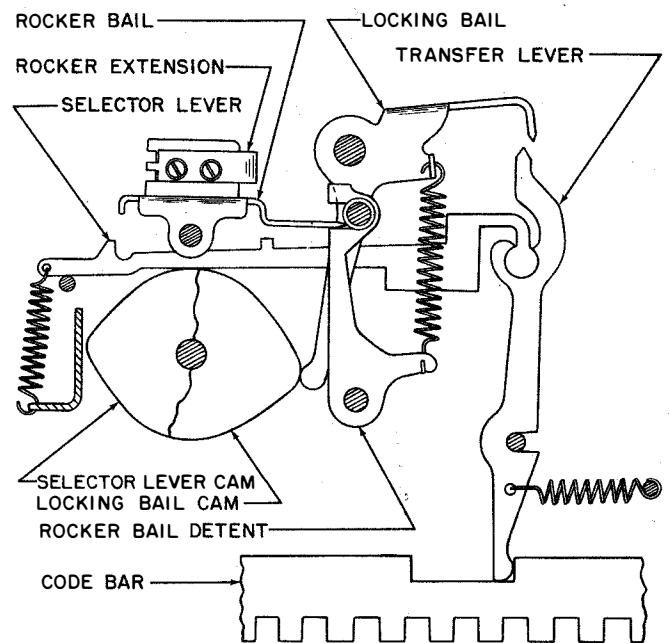


Figure 2-14. Signal Generator Mechanism, Front View

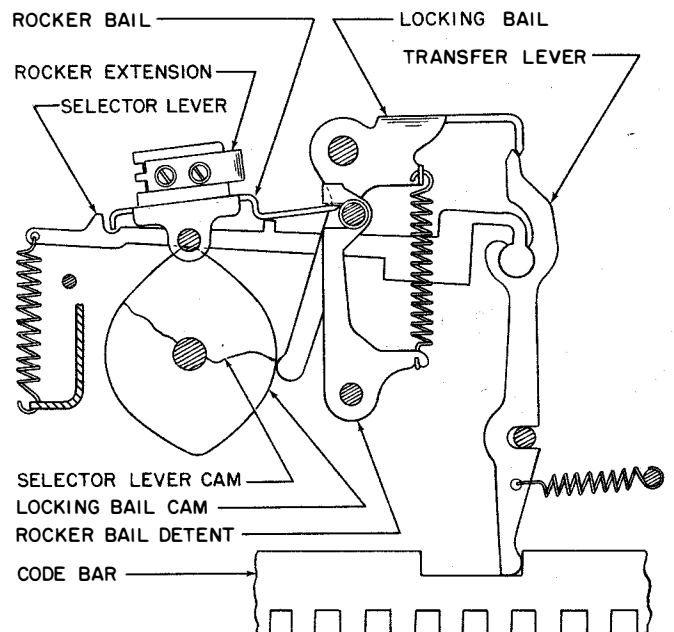


Figure 2-15. Signal Generator Mechanism, Front View

An extension on the rocker bail is moved downward or upward respectively with clockwise or counterclockwise rotation of the bail. On the rear side of the signal generator mechanism, are located the upper or spacing intermediate lever, the lower or marking intermediate lever, the oscillating lever, the flutter lever, the detent toggle and lever, and the contact assembly K-101. In the stop position, the rocker extension holds the mark-

ing intermediate lever downward and out of engagement with the flutter lever (figure 2-16). As the flutter cam on the keyboard cam-clutch assembly rotates, it moves the flutter lever and the spacing intermediate lever toward the left as viewed from the rear (figure 2-17). The spacing intermediate lever bears on the upper part of the oscillating lever and rotates it counter-clockwise so that the detent toggle is shifted toward the left where it is held by the detent lever. The detent toggle moves the toggle extension in the contact assembly toward the left and causes the contact toggle to pivot on the spacing contact and break the marking contact (figure 2-18). This breaks the line circuit which passes through the contact toggle and the marking contact and originates a start or spacing element of the signaling code. When the rocker extension is in its upward position, it holds the spacing intermediate lever upward out of engagement with the flutter lever (figure 2-19). Further rotation of the flutter cam moves the flutter lever and the marking intermediate lever toward the left. The marking intermediate lever bears on the lower part of the oscillating lever and rotates it clockwise so that the detent toggle is shifted to the right where again it is held by the detent lever. The detent toggle moves the toggle extension in the contact assembly toward the right and causes the contact toggle to close with the marking contact and pivot on it (figure 2-20). This closes the line circuit and originates a marking element of the signaling code. The electrical noise suppressor Z-101 is in the line circuit to aid in the suppression of undesirable radiation when the circuit is broken.

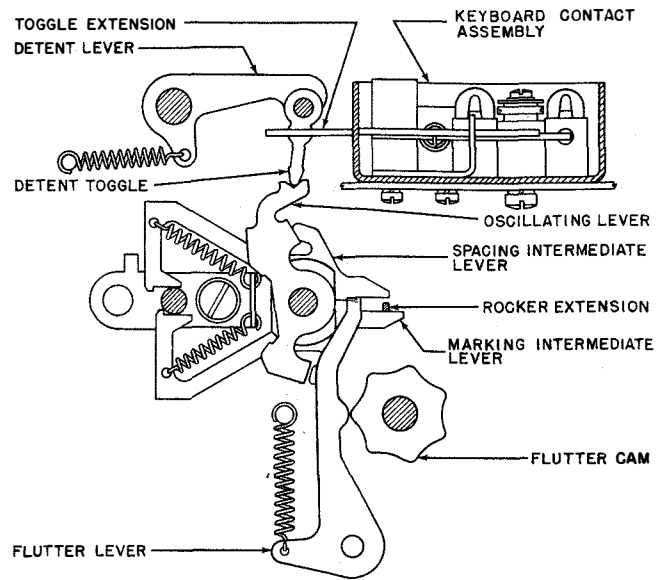


Figure 2-17. Signal Generator, Rear View, Spacing Position

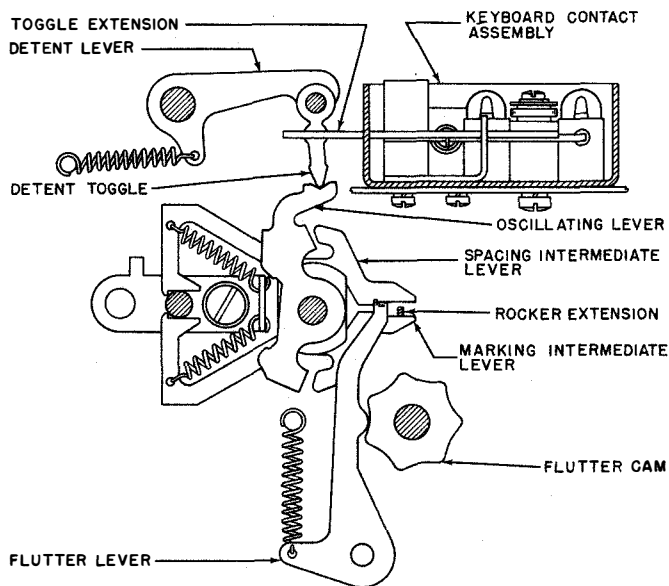


Figure 2-16. Signal Generator, Rear View, Stop Position

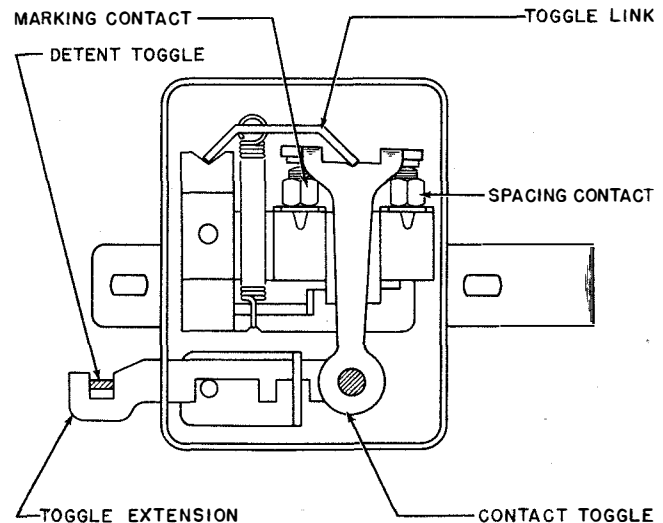
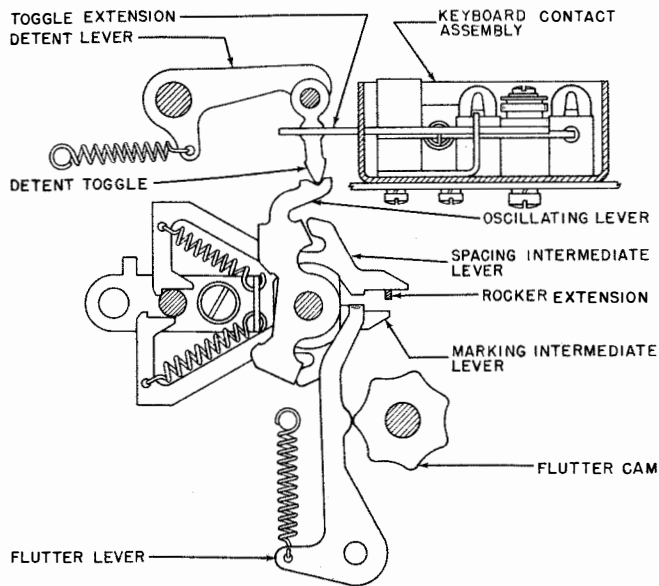


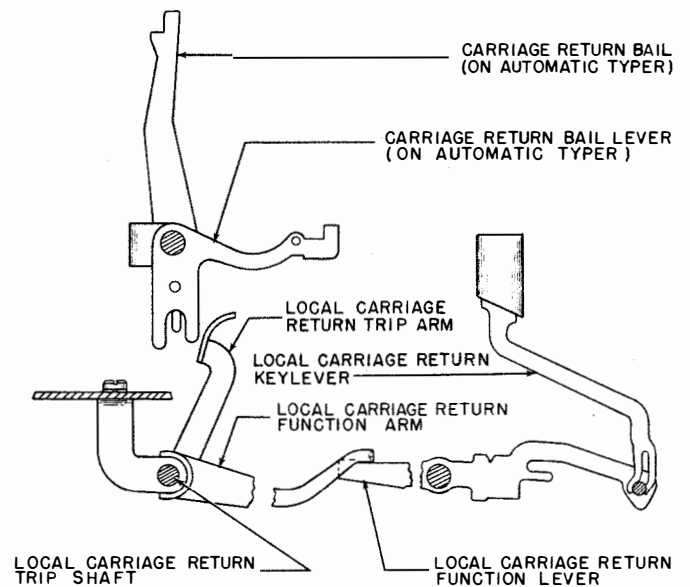
Figure 2-18. Contact Assembly, Spacing Position

**e. LOCAL CARRIAGE RETURN MECHANISM.**— Operation of the local carriage return keylever (red) causes its function lever to raise the end of the local carriage return function arm (figure 2-21). The function arm rotates the trip shaft and hence the trip arm. The trip arm engages the carriage return lever on the Automatic Typewriter. Thus, the carriage return mechanism on the local Automatic Typewriter is made to operate without disturbing the line circuit. The carriage return mechanism is fully described in paragraph 4.i.(4) of this section.

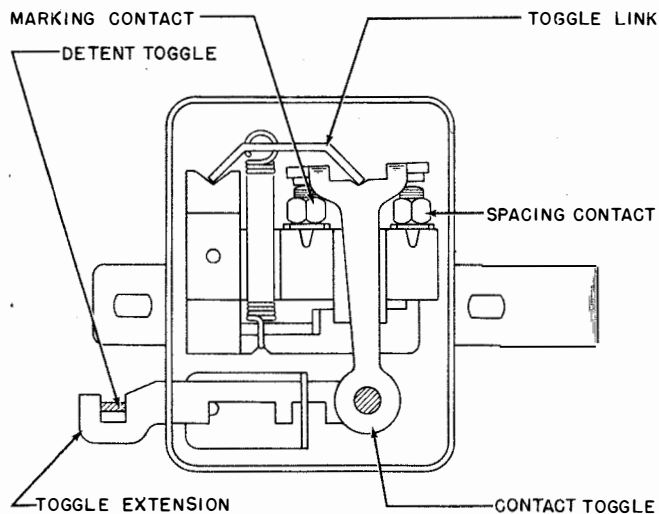
**THEORY OF OPERATION**



**Figure 2-19. Signal Generator, Rear View, Marking Position**

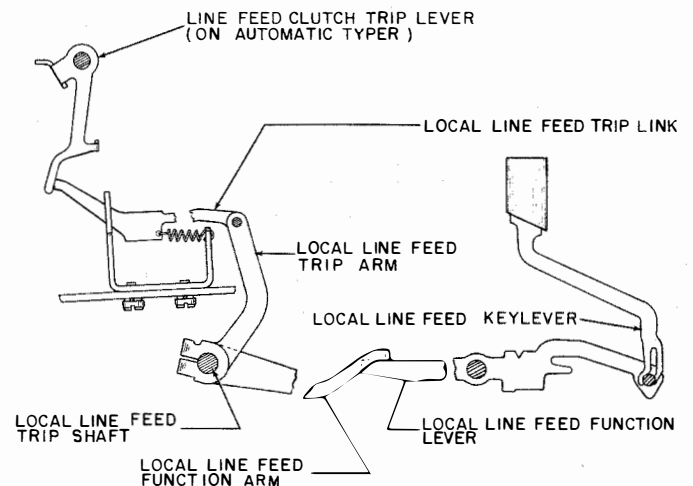


**Figure 2-21. Local Carriage Return Mechanism**



**Figure 2-20. Contact Assembly, Marking Position**

f. LOCAL LINE FEED.—Operation of the local line feed keylever (red) causes its function lever to raise the end of the local line feed function arm (figure 2-22). The function arm rotates the trip shaft and thus the trip arm. The trip arm pushes the trip link until the link engages the line feed clutch trip lever on the Automatic Typewriter. Thus, the line feed mechanism on the local Automatic Typewriter is made to operate without disturbing the other Automatic Typewriters on the same line circuit. The line feed mechanism is fully described in paragraph 4.i.(5) of this section.



**Figure 2-22. Local Line Feed Mechanism**

g. BREAK MECHANISM.—Operation of the break keylever (red) causes its function lever to raise the break rod and shift the break bail (figure 2-23). As the break bail moves upward, its lower end engages the lower end of the oscillating lever to rotate the lever counterclockwise as viewed from the rear (figure 2-24). The oscillating lever shifts the detent toggle toward the left where it is held by the detent lever. The detent toggle moves the toggle extension in the contact assembly toward the left and causes the contact toggle to pivot on the spacing contact and break the marking contact (figure 2-18). This breaks the line circuit until the break keylever is released. When the keylever is released, a spring on the break bail moves it downward.

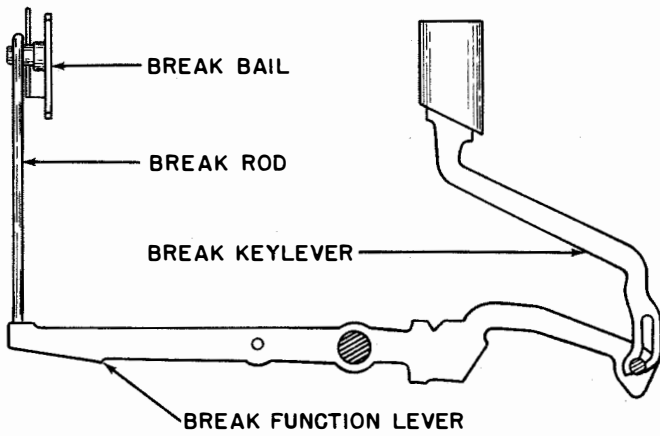


Figure 2-23. Break Mechanism

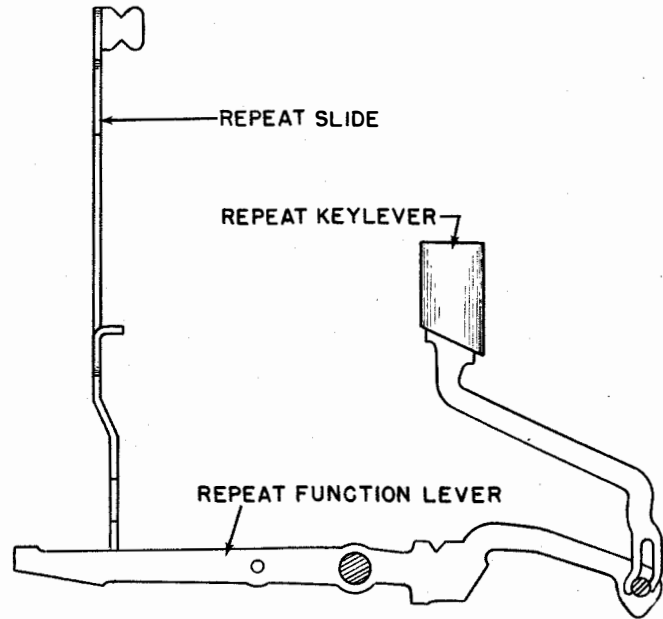


Figure 2-25. Repeat Mechanism

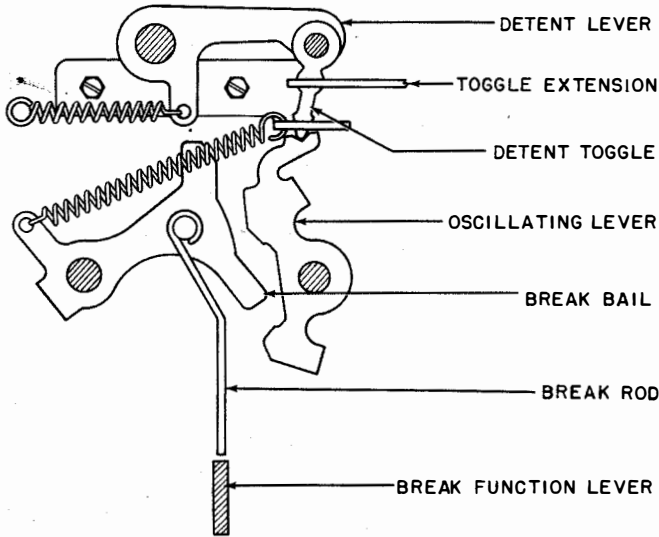


Figure 2-24. Break Mechanism

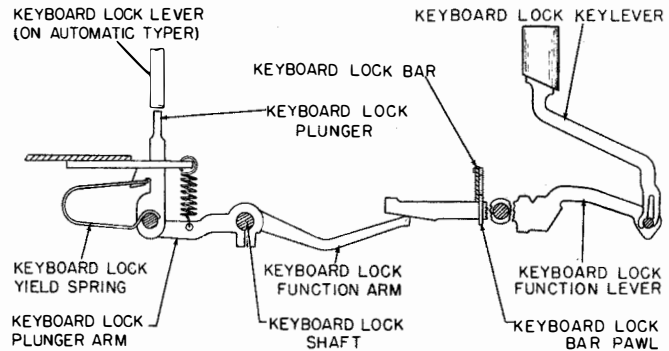


Figure 2-26. Keyboard Lock Mechanism

The upper end of the bail engages the upper end of the oscillating lever to rotate it clockwise and close the contacts in the contact assembly.

*b. REPEAT MECHANISM.*—Operation of the repeat keylever (red) simultaneously with one of the green keylevers or the space bar, causes the character or function selected to be repeated as long as the key levers are held operated. The operated repeat keylever causes its function lever to raise the repeat slide (figure 2-25). As the repeat slide is held in its upward position, it prevents the code bar bail from being latched up by its latch lever (figure 2-9).

*i. KEYBOARD LOCK MECHANISM.*—Operation of the keyboard lock keylever (red) causes its function lever to raise the keyboard lock bar pawl (figure 2-26).

As shown in paragraph 4.i.(8) of this section, the reception of two consecutive blank code signals by the Automatic Typewriter, results in its driving its keyboard lock lever downward. The lock lever makes contact with the lock plunger on the Keyboard and also pushes it downward. As the plunger moves, it exerts pressure on the yield spring which connects it with the keyboard lock plunger arm. The arm moves downward to turn the keyboard lock shaft and raise the keyboard lock function arm. This engages the keyboard lock function lever and causes it to raise the lock bar pawl. Thus, the pawl may be raised either by local operation of the keyboard lock keylever, or by operation of the blank or break keylevers, on any Keyboard in the line circuit. In its upper position, the pawl releases the keyboard lock

bar and a spring pulls the bar toward the right (figure 2-28). In this position, projections on the lower side of the bar block the upward movement of any code lever and the repeat function lever.

j. **KEYBOARD UNLOCK MECHANISM.**—Operation of the keyboard unlock keylever (red) causes its function lever to rise against a camming surface on the keyboard lock bar and drive the bar toward the left until the lock bar pawl drops into a notch in the lock bar (figures 2-27 and 2-28). In this position, the projections on the lock bar lie between the code levers and offer no interference with their operation.

k. **MARGIN INDICATOR MECHANISM.**—The margin indicator cam disk on the automatic typer spring drum rotates with the drum as printing or spacing occur. See paragraph 4.g.(1) of this section. As the end of each line is approached, the cam surface of the disk makes contact with the margin indicator contact lever and rotates it clockwise about its pivot point (figure 2-29). When the contact lever leaves the switch plunger, the switch S-102 operates and closes the circuit to a margin indicator light I-751 in the Cabinet (figures 2-3 and 2-79). A carriage return cycle returns the cam disk to its starting position and the margin indicator light switch reopens.

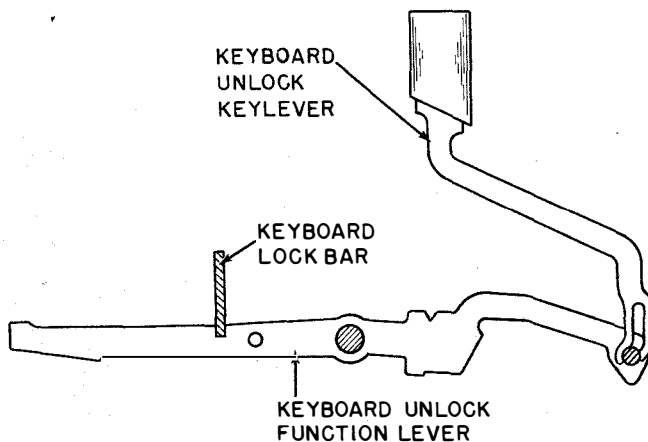


Figure 2-27. Keyboard Unlock Mechanism

l. **TIME DELAY MECHANISM.**—As shown in paragraph 6.c. of this section the electrical motor control mechanism in the Power Distribution Panel must receive an electrical pulse to stop the AC Motor. This pulse is supplied by the time delay mechanism on the Keyboard which contains two ratchet wheels—one with 27 teeth, and one with 28 teeth. The reciprocating eccentric follower pawl, powered by the intermediate shaft, drives the ratchet wheels one tooth at a time (figure 2-30). Therefore, the ratchet wheel with 27 teeth

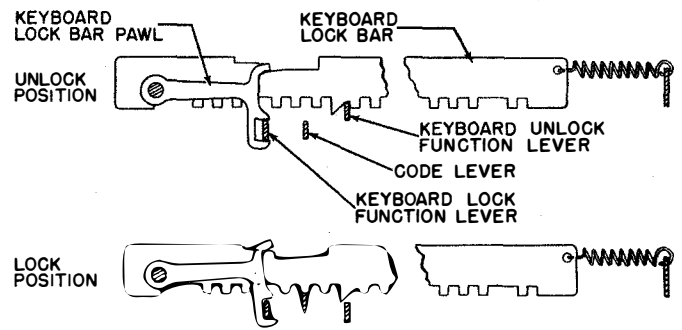


Figure 2-28. Keyboard Lock Mechanism

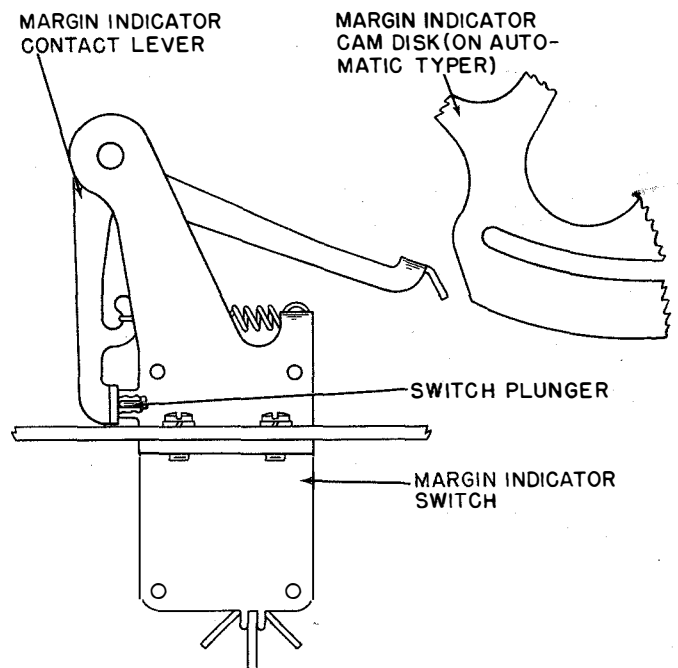


Figure 2-29. Margin Indicator Mechanism

turns a little faster than the one with 28 teeth. The latch pawl rides the inside flanges of the ratchet wheels. The contact pawl is held away from the flanges by the contact pawl latching lever which is controlled by the latch pawl. Each ratchet wheel has an indentation in its inside flange. After a maximum of 756 revolutions of the intermediate shaft, these indentations are adjacent for nearly one revolution. When the adjacent indentations pass over the latch pawl, it drops into them briefly and disengages the contact pawl latching lever from the contact pawl. This allows the contact pawl to ride the flanges of the ratchet wheels until either one of two things occur (figure 2-31). If a line signal is received before 756 revolutions of the intermediate shaft have taken place, the main bail drive bracket extension on

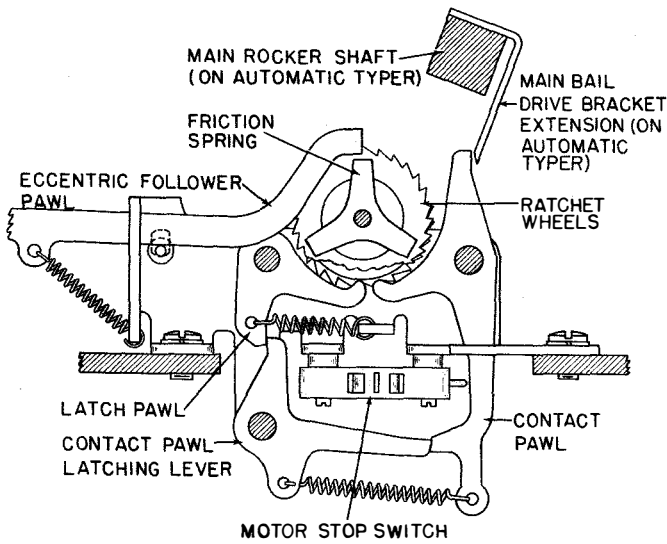


Figure 2-30. Time Delay Mechanism

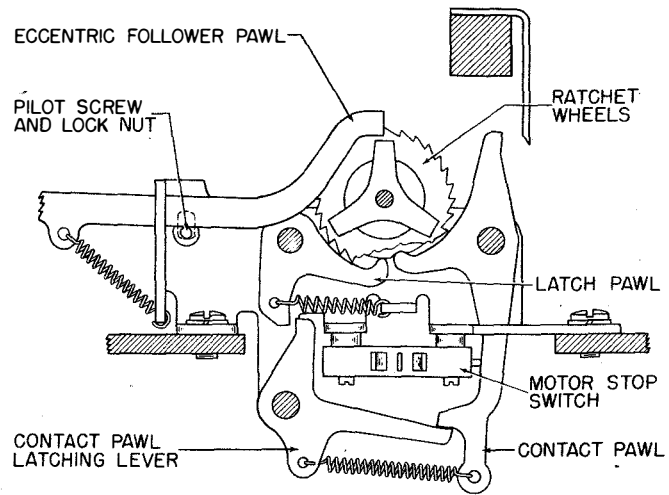


Figure 2-32. Time Delay Mechanism

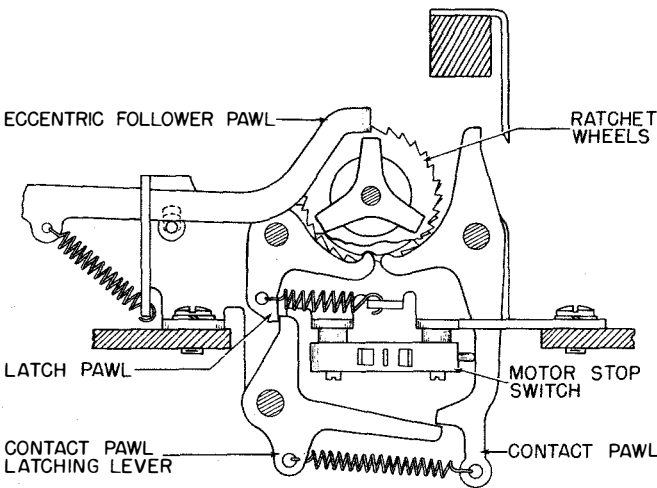


Figure 2-31. Time Delay Mechanism

the Automatic Typewriter engages the upper end of the contact pawl and causes it to again be latched by the contact pawl latching lever. If a line signal is not received before 756 revolutions of the intermediate shaft occur, the indentations in the flanges of the ratchet wheels again become adjacent so as to permit the contact pawl to drop into them briefly, and pulse the motor stop switch S-101 (figure 2-32). This pulse is applied to the electrical motor control mechanism in the Power Distribution Panel to shut down the motor. The time lapse between the reception of the last line signal and the shutting down of the motor varies from 86 to 172 seconds for 60 words per minute operation, and from 53 to 106 seconds for 100 words per minute operation.

If it is not desirable to have the motor shut down automatically, the time delay mechanism may be disabled. To accomplish this, loosen the nut on the pilot screw, raise it to the top of its slot, and tighten the nut. When the pilot screw is in this position, the eccentric follower pawl is held out of engagement with the ratchet wheels.

#### 4. AUTOMATIC TYPER MX-1115/UG.

##### a. RECEIVING CIRCUIT. (See figure 2-33.)

(1) The receiving circuit for the Automatic Typewriter consists of two 132 ohm selector magnet coils E-1304 and E-1305 wired to a receptacle J-1301 which is mounted on the automatic typewriter right frame. At the time the Automatic Typewriter is installed in its cabinet, a connector P-1102 on the end of a rubber covered cable which emanates from the Power Distribution Panel, is plugged into this receptacle. A terminal block TB-1103 in the Power Distribution Panel provides for the connection of the selector magnet coils in series for 0.020 ampere line current operation, or in parallel for 0.060 ampere line current operation.

(2) The Automatic Typewriter also has a set of electrical contacts E-1301 and E-1302 which are connected to the receptacle J-1301 on its right frame. These are used to pulse a signal bell magnet E-756 in the cabinet and are operated by a mechanism described in paragraph 4.i.(7).

##### b. MAIN SHAFT. (See figure 2-34.)

(1) The main shaft is located in the lower rear portion of the Automatic Typewriter and extends the full length of the unit. It is supported by ball type bearings mounted in each side frame.

(2) At the time the Automatic Typewriter is mounted on a Keyboard, the keyboard helical driving gear on its main shaft meshes with the signal generator helical driven gear. The main shaft helical driven gear meshes

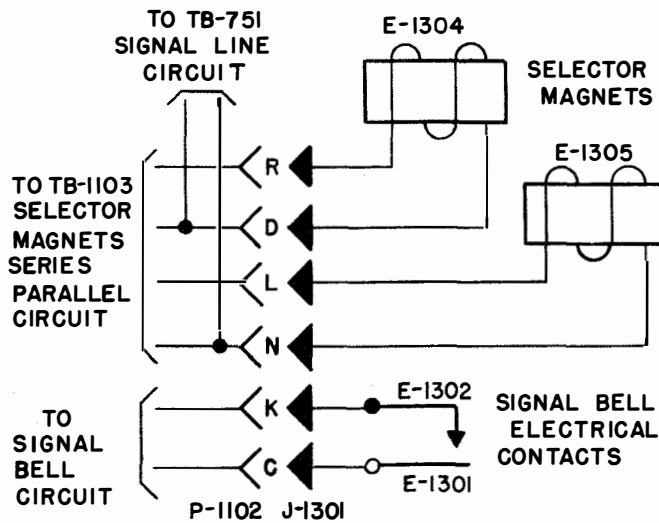


Figure 2-33. Automatic Typewriter MX-1115/UG,  
Schematic Wiring Diagram

with the main shaft helical driving gear on the motor driven intermediate shaft on the Keyboard. Thus motive force is extended from the motor to the main shaft which in turn drives the keyboard mechanism.

(3) The main shaft carries six clutches each of which, when tripped drives its associated mechanism. These clutches are of the friction type and have two shoes which bear against the inside surface of a drum which in turn is keyed to the main shaft. They operate as follows:

(a) Figure 2-35 shows a clutch disengaged. Disengagement is accomplished by bringing together lug A on the clutch cam disk, and the lower end of clutch shoe lever B. The upper end of lever B pivots about its ear C and allows its other ear D to move toward the right. The upper spring then pulls the two shoes together and away from the drum.

(b) Figure 2-36 shows the same clutch engaged. This is accomplished by releasing lug A and the lower end of lever B. The upper end of lever B pivots about its ear C (which bears against the upper end of the secondary shoe) and moves its ear D, and the upper end of the primary shoe, toward the left until the shoe makes contact with the drum at point E. The drum, in turning counterclockwise, drives the primary shoe downward, so that it again makes contact with the drum, this time at point F. There, the combined forces acting on the primary shoe cause it to push against the secondary shoe at point G. The lower end of the secondary shoe then bears against the drum at point H. The revolving drum acts to drive this shoe upward so that it again makes contact with the drum at point I. Since the forces involved are multiplied at each of the

preceding steps, the final force developed at point I is very great. This force is applied to the lug J on the clutch cam disk to cause it to turn in step with the drum. The cam disk on each clutch is connected with the particular mechanism involved.

(c) Two of the clutches (namely the line feed and the spacing clutches) have three sets of lugs equally spaced about their periphery for controlling the engagement and disengagement of the clutch shoes with the drum. Thus, these clutches may turn only one third of a revolution when tripped. The function clutch has two sets of lugs diametrically opposite of each other and may turn one half a revolution only when tripped. The remaining clutches have one set of lugs, and must turn a complete revolution when tripped.

#### c. SELECTING MECHANISM.

(1) The selecting mechanism consists of the selector magnet coils E-1304 and E-1305 and armature, a selector cam-clutch and the associated levers, arms, bails, and slides necessary to convert the electrical elements of the start-stop code to the mechanical arrangements which govern the characters to be printed and the functions to be performed.

(2) The selector cam-clutch comprises, from right to left (figure 2-34), the clutch, the clutch stop arm operating cail cam, the fifth, the fourth, and the third selector lever cams, the spacing and the marking lock lever cams, the second and the first selector lever cams, the push lever reset bail cam, and the code bar clutch trip cam.

(3) During the time in which a closed line circuit (marking) condition exists, the selector magnet coils are energized and hold the selector armature against the selector magnet core pole pieces. In this stop position, the selector armature blocks the spacing lock lever (figure 2-37). While the signal for any character or function is being received, the start (spacing) element releases the selector armature which, under the tension of its spring, moves away from the magnet cores and thus unlatches the spacing lock lever. As the spacing lock lever turns clockwise under the tension of its spring, it drops into an indent on its flutter-type cam. The spacing lock lever follower and the selector clutch stop arm operating bail also turn clockwise under the tension of their spring as the follower rides the spacing lock lever. The stop arm operating bail moves the selector clutch stop arm out of engagement with the clutch shoe lever. The selector clutch engages and begins to rotate. To prevent the spacing lock lever follower from loading the spacing lock lever during the signalling time, the stop arm operating bail rides a cam. Thus, the spacing lock lever follower rides the spacing lock lever only during the stop time. When the stop element at the end of the signal is received, the spacing lock

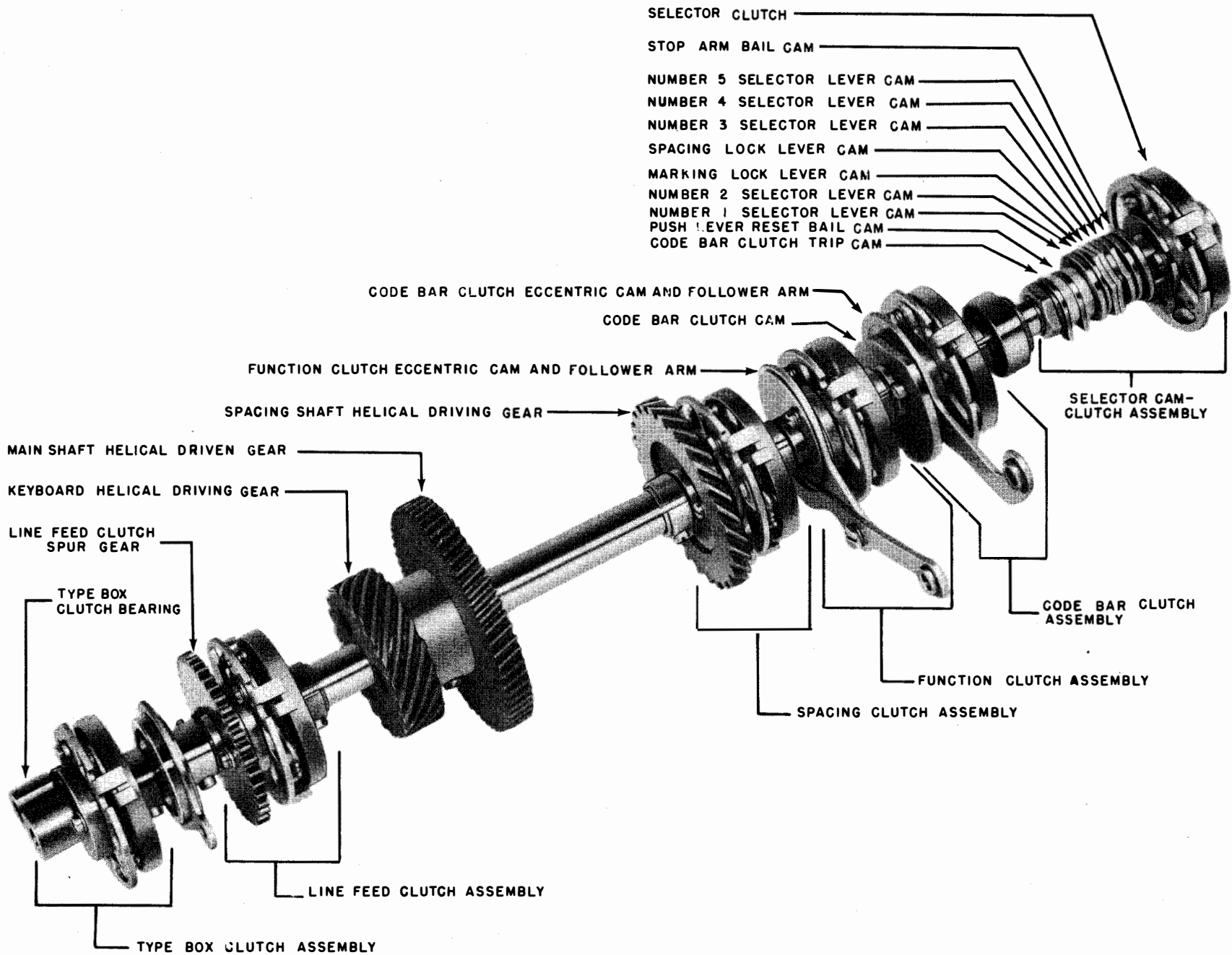


Figure 2-34. Automatic Typewriter Main Shaft



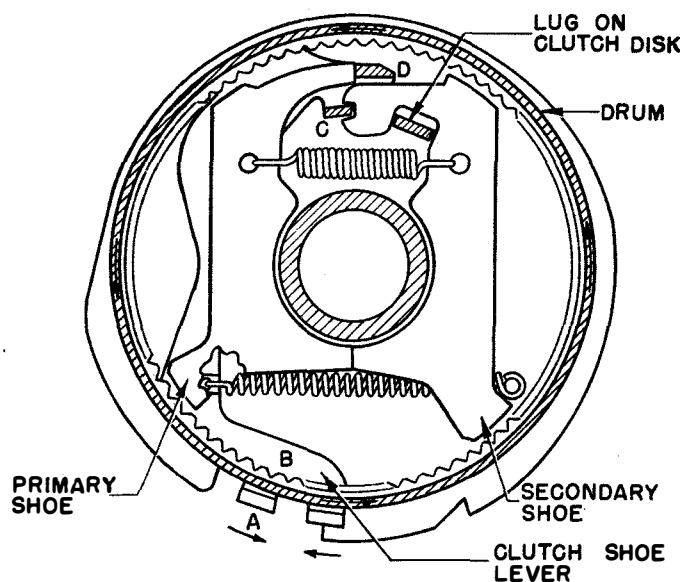


Figure 2-35. Clutch, Disengaged

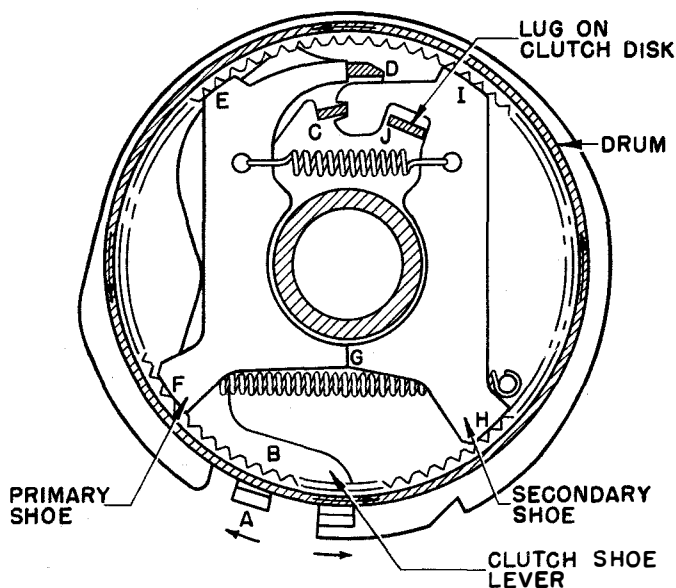


Figure 2-36. Clutch, Engaged

lever is on a high point of its cam and is latched by the armature. In this position, through the intervening spacing lock lever follower and stop arm operating bail, the selector clutch stop arm is held so as to stop the clutch shoe lever. The selector clutch one-stop cam disk has an indent at its stop position. The selector clutch latch lever follows this cam disk and is thereby held away from the clutch drum until the lug on the clutch shoe lever passes under the latch lever and is stopped by the selector clutch stop arm. Due to its inertia, the

one-stop clutch cam disk continues to turn until its lug makes contact with the lug on the clutch shoe lever. At this point the latch lever drops into the indent in the cam disk, and the clutch is held disengaged until the next start element is received.

(4) A series of five selecting levers and a marking lock lever ride their respective cams on the selector cam-clutch. As the marking and spacing signal elements are applied to the selector magnet, the selector cam-clutch rotates and actuates the selector levers. When a spacing impulse is received, the marking lock lever is blocked by the end of the armature and the spacing lock lever swings toward the right (right end view) above the armature and locks it in the spacing position until the next signal transition is due. Extensions on the marking lock lever prevent the selector levers from following their cams (figure 2-38). When a marking element of the signal is received, the spacing lock lever is blocked by the end of the armature and the marking lock lever swings to the right below the armature to lock it in the marking position until the next signal transition is due. During this marking condition, the selector levers are not blocked by the marking lock lever extensions but are permitted to move against their respective cams. The selecting lever that is opposite the indent in its cam, while the armature maintains a marking condition, swings to the right or selected position momentarily. Each selecting lever has an associated push lever which drops into a notch on the top of the selecting lever when it falls into its cam indent. As the selector cam-clutch turns, each selected selecting lever together with its latched push lever is moved toward the left and held there until all five code impulses have been received. At that time, all selected push levers are positioned to the left and all unselected push levers are positioned to the right in which positions they are held until the next start element is received. When the subsequent start element again causes the selector cam-clutch to rotate, the push lever reset bail, in following its cam, unlatches the selected push levers. The push levers then return to the unselected (right) position under their spring tension.

d. ORIENTATION.

(1) In order to establish operating margins for the Automatic Typewriter, it is necessary that the sampling of the signal by the selecting mechanism occur at the most favorable portion of the signal elements. This is referred to as orientation.

(2) When the range scale positioning knob is loosened, the range scale pointer, the spacing lock lever follower, the clutch stop arm with operating bail, and the clutch latch lever, may be moved as a group, either clockwise or counterclockwise about the selector cam-clutch (figure 2-37). This changes the angular position

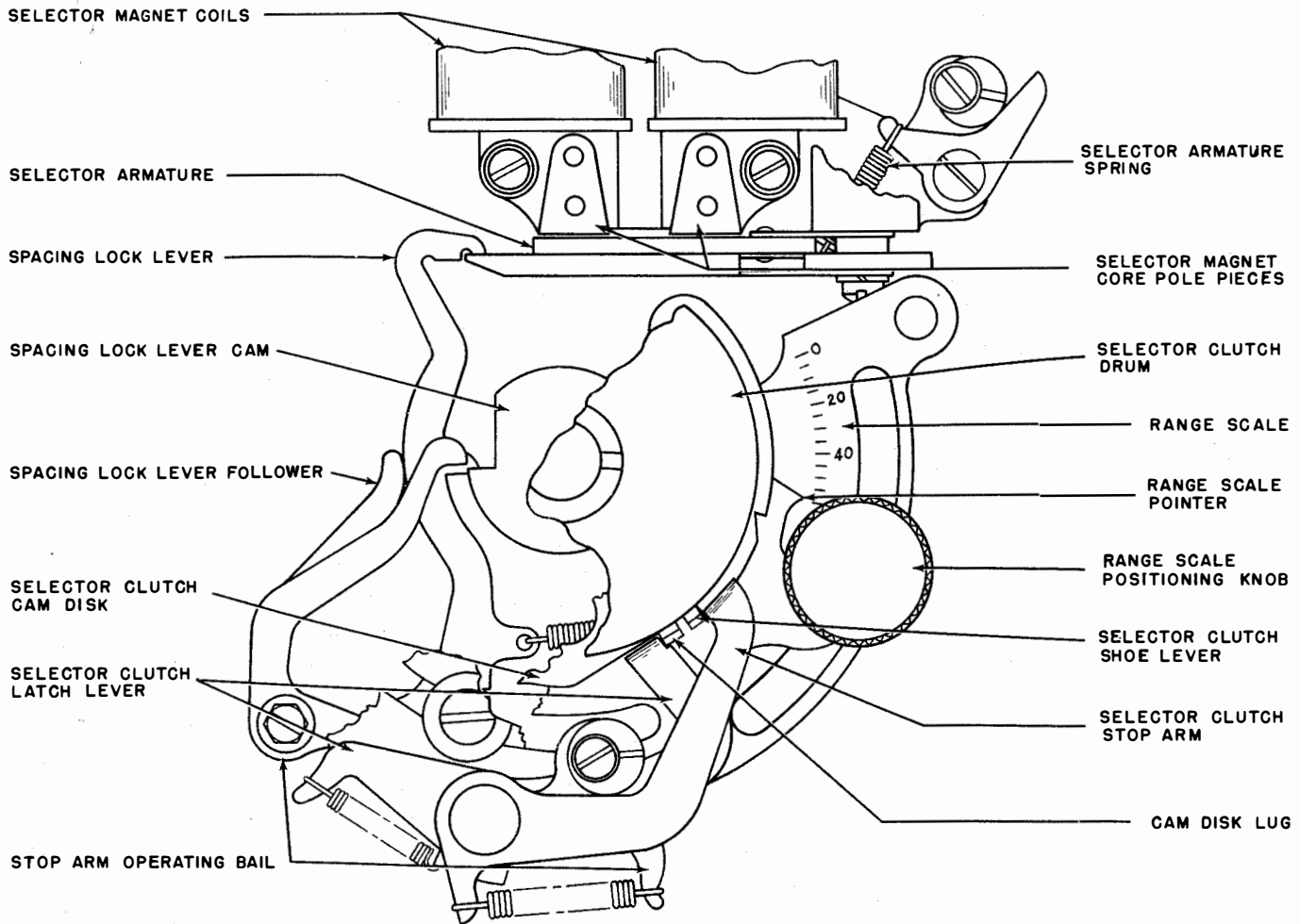


Figure 2-37. Selector Cam Clutch Trip Mechanism

at which the selector cam-clutch stops with respect to the selecting levers.

e. PRINTING MECHANISM.

(1) CODE BAR MECHANISM.

(a) GENERAL.—The character which is to be printed is determined basically by the combination set up on the six code bars which are operated by the code bar positioning mechanism. In order to position the code bars, their associated shift bars must first be individually thrown toward the front or rear of the Automatic Typewriter by transfer levers which respond to action of the selecting mechanism. While held in these positions, the code bar shift bars are acted upon by code bar shift levers to which motion is extended from the code bar clutch when activated by the code bar clutch trip cam. Detailed functioning of the coordinated mechanism follow.

(b) CODE BAR POSITIONING.—Each push lever (paragraph 4.c.(4) of this section) has an associated intermediate arm, transfer lever, and code bar

shift bar (figure 2-39). In addition there is a "common" transfer lever with its code bar shift bar. When a push lever is toward the right (space position) its associated intermediate arm and transfer lever are pulled toward each other by a spring. This causes the transfer lever to turn counterclockwise about its pivot point (right end view) and position its code bar shift bar toward the front of the Automatic Typewriter (space position). When a push lever is to the left (mark position), it moves the intermediate arm toward the left. This causes the transfer lever to turn clockwise about its pivot point and position its code bar shift bar toward the rear of the Automatic Typewriter (mark position). The common transfer lever (front view—third from the left) has an extension which passes behind the number one and number two transfer levers (figures 2-40 and 2-41). When either or both of these transfer levers are moved to the rear (mark position), they move the common transfer lever to the rear. This in turn moves the common code bar shift bar toward the rear of the Automatic Typewriter (mark position). As

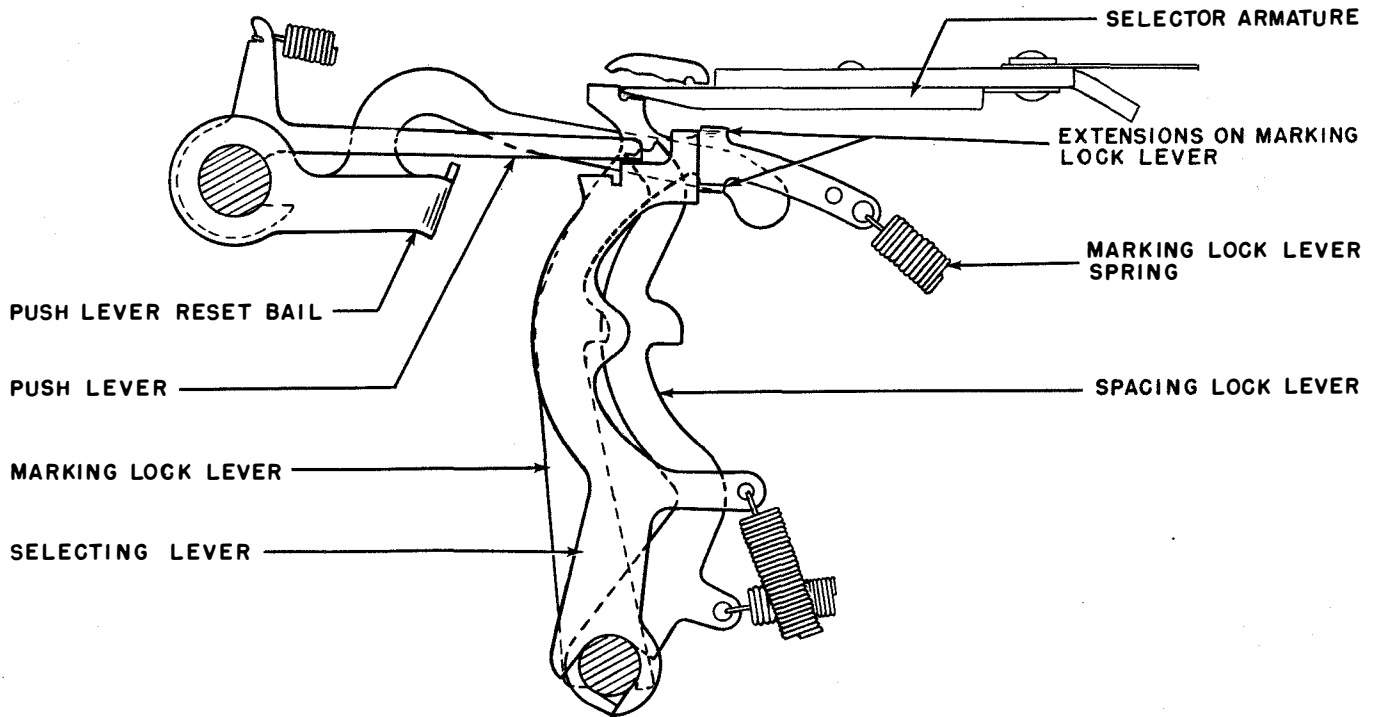


Figure 2-38. Selecting Mechanism, Right End View

the selector cam-clutch completes its revolution, a trip-shaft operating lever (fastened to the code bar clutch trip shaft) drops into the indent of the code bar clutch trip cam (figure 2-34). This causes the shaft to turn slightly and its attached code bar clutch trip lever releases the code bar clutch. Rotation of the clutch actuates the code bar shift levers through the intervening shift lever drive shaft, drive arm, and shift lever link (figure 2-40). Code bar shift bars which have been moved toward the rear position by their transfer levers are engaged by the rear code bar shift lever and are shifted to the left. Code bar shift bars which have been moved toward the front position are engaged by the front code bar shift lever and are shifted toward the right (figure 2-41). Thus, the six code bar shift bars shift their respective code bars toward the right or left where they are retained by a detenting mechanism. The code bar clutch one-stop cam disk has an indent at its stop position. The code bar clutch latch lever follows this cam disk and is thereby held away from the clutch drum until the lug on the clutch shoe release lever passes under the latch lever and is stopped by the code bar clutch trip lever. Due to its inertia, the one-stop clutch cam disk continues to turn until its lug makes contact with the lug on the clutch shoe lever. At this point the latch lever drops into the indent in the cam disk, and the clutch is held disengaged until the trip lever is again operated.

ORIGINAL

#### (c) ARRANGEMENT OF CODE BARS.

Three additional code bars bring the total number of code bars to nine. They are arranged from top to bottom as follows: suppression, number 4, number 1, number 5, number 2, number 3, common, automatic carriage return and line feed, and shift-unshift (figure 2-42). In the equipment as furnished the suppression code bar has no connection with a shifting mechanism. The automatic carriage return and line feed code bar and the shift-unshift code bar are actuated by mechanisms which will be discussed under "functions."

#### (2) TYPE BOX AND TYPE BOX CARRIAGE.

(a) GENERAL.—All of the characters that may be printed by the Automatic Typewriter are formed by type pallets which are arranged in a type box. The type box is mounted in a carriage from which it may be removed for cleaning or replacement. In order to print any selected character the type box carriage is so positioned that the character on the pallet is directly over the required location on the paper. Since the pallets are arranged in four horizontal rows and sixteen vertical rows, it is necessary to position the type box carriage both horizontally and vertically. See figure 2-43 for character arrangement. The type box carriage rides on rollers over a track which is moved vertically for positioning in that particular plane. The carriage is positioned horizon-

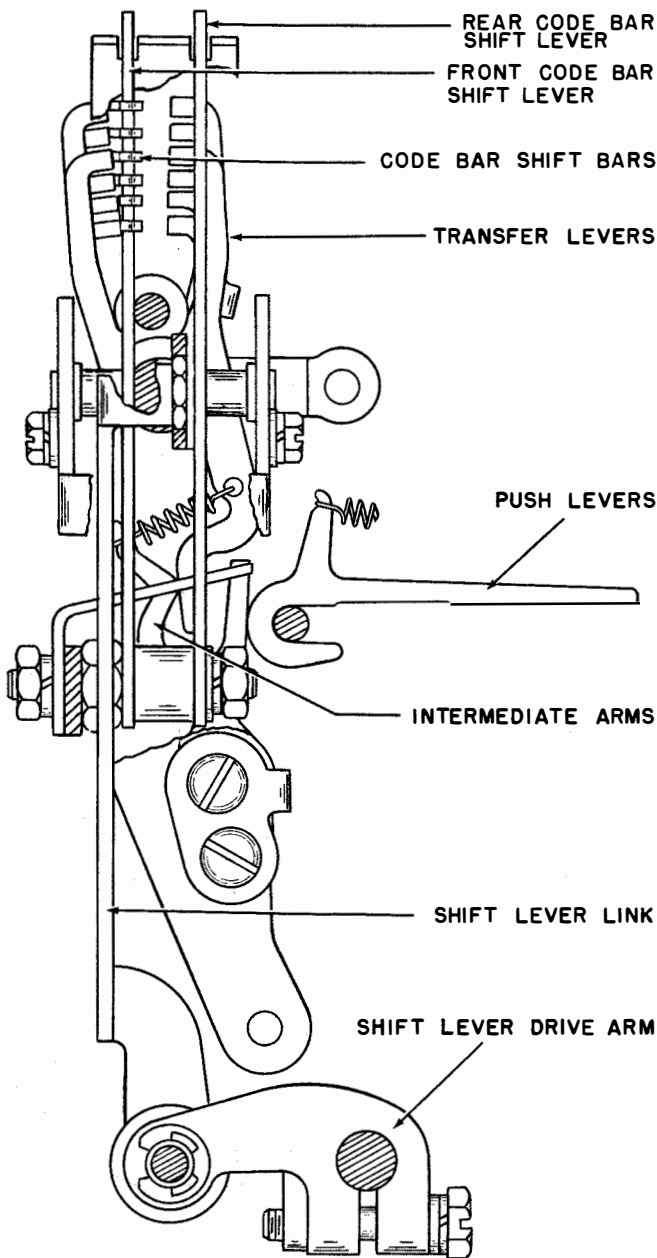


Figure 2-39. Code Bar Positioning Mechanism

tally on its track by the oscillating rail slide and type box carriage link. The slide rides the oscillating rail and is clamped to the rear section of the upper draw wire rope. The link provides a flexible connection to permit the type box carriage to follow both the vertical movement of the type box carriage track and the horizontal movement of the oscillating rail slide. The lower right rear end of the upper draw wire rope is fastened to the spacing drum. From this point, it passes part way around the spacing drum, upward and around the right oscillating rail pulley, over to the left oscillating rail pulley, and downward to the spring drum. After

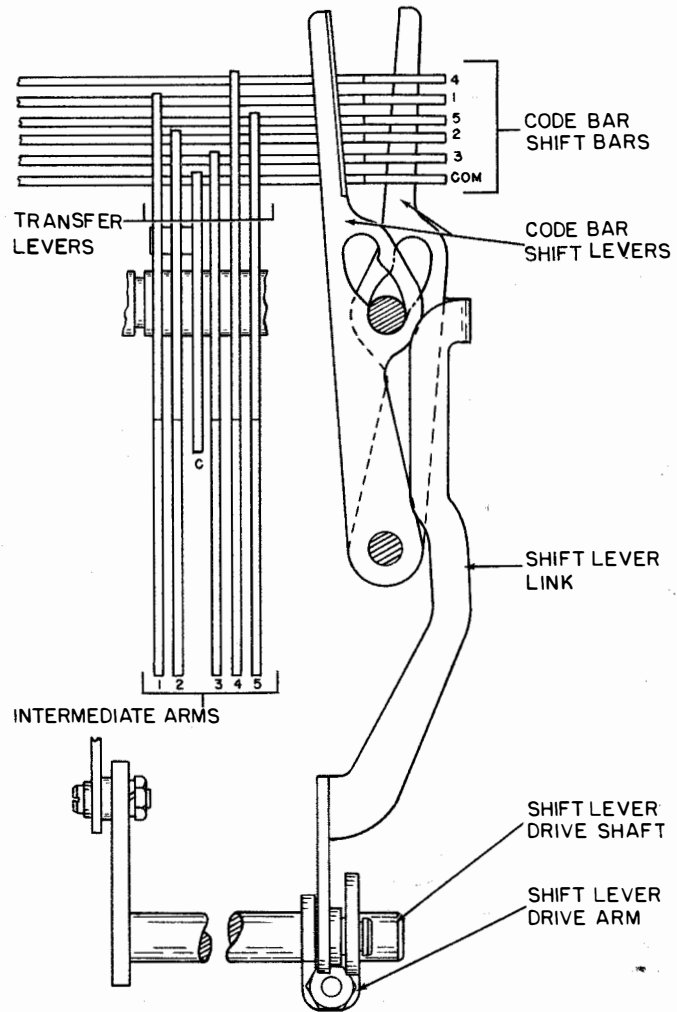


Figure 2-40. Code Bar Positioning Mechanism, Front View

passing part way around the spring drum, the upper draw wire rope is doubled backward around it and passes upward to the left printing carriage rail pulley, over to the right printing carriage rail pulley, and downward to the spacing drum to which it is again fastened. The lower draw wire rope is fastened at its left end to the spring drum and, at its right end, to the spacing drum. It acts in opposition to the upper draw wire rope and holds the two drums in phase (figure 2-44). A tensioning pulley rides the underside of the lower draw wire rope, to take up any slack which may occur due to stretching of the upper and lower draw wire ropes. The oscillating rail is supported by pivoted arms at each end. These arms which extend downward are pivoted to the automatic typer frame at their lower ends. Thus, the oscillating rail and the draw wire rope that it carries may be shifted to the left or right with no change in position relative to each other. The oscillating rail shift slide and two oscillating rail shift links are used

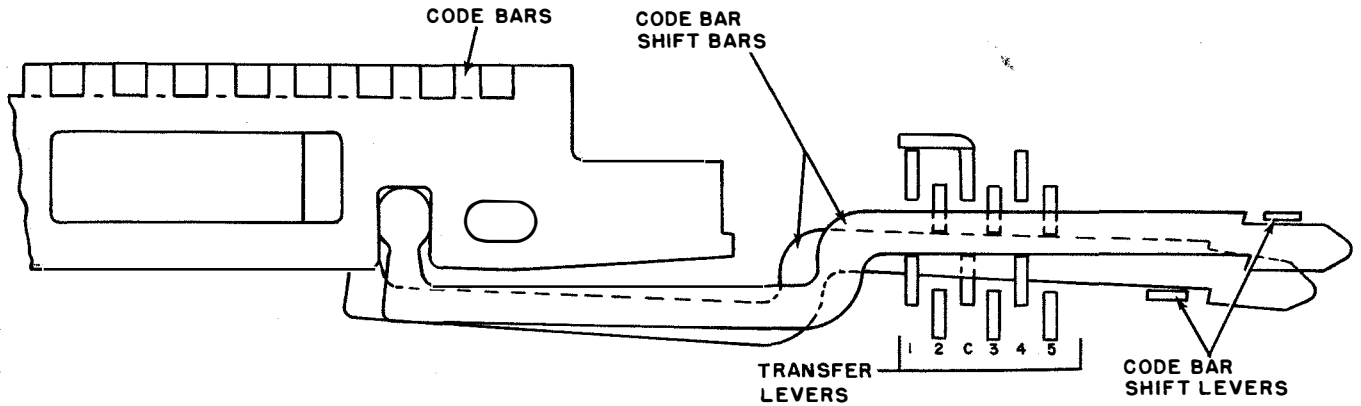


Figure 2-41. Code Bar Positioning Mechanism, Top View

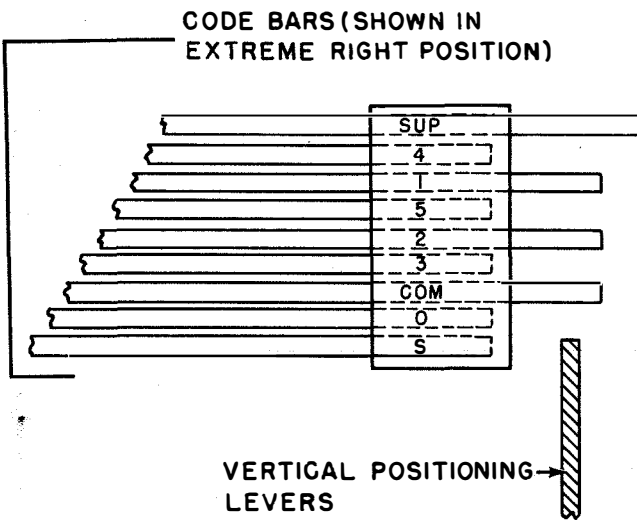


Figure 2-42. Code Bar Arrangement

to accomplish the horizontal positioning of the oscillating rail and also connect it with the oscillating rail shift slide. The links are pivoted and are of such a length that only one at a time may be fully extended. As will be shown later under "functions," the oscillating rail shift links are used to position the oscillating rail and thus the type box, so that either the left end (letters), or the right end (figures), of the type box is selected.

(b) POSITIONING.—The selection of the various characters from the four horizontal rows and the eight vertical rows in either the left (letters) end or the right (figures) end of the type box, and the printing of those characters take place as follows:

1. Briefly, the number 1 and number 2 code bars determine the selection of the horizontal row. The number 3 code bar determines whether the selection is to be made from the left four vertical rows or right four vertical rows (in either the LETTERS or FIGURES

end). The number 4 and number 5 code bars determine the selection of one row from the four vertical rows predetermined by the number 3 bar.

2. Four code bars (longer than the others), extend through the right code bar bracket and serve as stops for the right "knee action" vertical positioning levers. They are (from top to bottom), suppression, number 1, number 2, and common (figure 2-42). Notches are arranged in the left ends of the code bars so that the left side "knee action" vertical positioning levers are stopped, in each case, by the same code bar that blocks the right side levers. After all the code bars have been positioned by the code bar positioning mechanism, the code bar clutch cam follower arm and its roller, in traversing the sloping indent on the code bar clutch cam, rotates the clutch trip lever shaft. As the shaft turns, it first causes the function clutch trip lever to release the function clutch (figure 2-45) and then causes the type box clutch trip arm to engage its trip lever and release the type box clutch. When the type box clutch completes its revolution, it is disengaged by its trip lever and latch lever in the same manner as was the code bar clutch, described in paragraph 4.e.(1)(b) of this section. During its rotation, the type box clutch operates a drive link and a bracket to cause the main rocker shaft to oscillate. This in turn, through its left and right brackets and the main side lever drive links, extends the motion to the main side levers to operate the "knee action" vertical positioning levers (figure 2-46). These levers are driven upward until they strike a projecting code bar which causes them to buckle. The type box carriage track is mounted between the vertical positioning levers and its vertical motion is controlled by them. When the number 1 and number 2 code bars are toward the right (spacing), the common code bar is also toward the right where it blocks the vertical positioning levers. The top row of pallets in the type box are then in line for printing. When the number 1 code bar is toward the left (marking), and the number 2

Figure 2-43. Type Box Arrangement, Viewed From Front of Automatic Typewriter

		LETTERS				FIGURES				
		LEFT		RIGHT		LEFT		RIGHT		
		4 B 5 MARKING	4 MARKING	4 SPACING	4 B 5 MARKING	4 B 5 MARKING	4 MARKING	4 SPACING	4 B 5 MARKING	
		5 SPACING	5 MARKING	5 MARKING	5 SPACING	5 MARKING	5 MARKING	5 MARKING	5 MARKING	
TOP ROW		M	N	H	SPACE	BLANK	T	C. R.	O	
		--3 4 5	--3 4--	--3-5	--3--	---	---5	---4-	---4 5	1 & 2 SPACING
2ND ROW		X	F	Y	S	E	Z	D	B	
		1-3 4 5	1-3 4-	1-3-5	1-3--	1---	1---5	1--4-	1--4 5	1 MARKING 2 SPACING
3RD ROW		V	C	P	I	L.F.	L	R	G	
		-2 3 4 5	-2 3 4-	-2 3-5	-2 3--	-2---	-2--5	-2-4-	-2-4 5	1 SPACING 2 MARKING
BOTTOM ROW		LETTERS	K	Q	U	A	W	J	FIGURES	
		1 2 3 4 5	1 2 3 4-	1 2 3-5	1 2 3--	1 2---	1 2--5	1 2-4-	1 2-4 5	1 & 2 MARKING
			3 MARKING				3 SPACING			
		4TH ROW	3RD ROW	2ND ROW	1ST ROW	1ST ROW	2ND ROW	3RD ROW	4TH ROW	

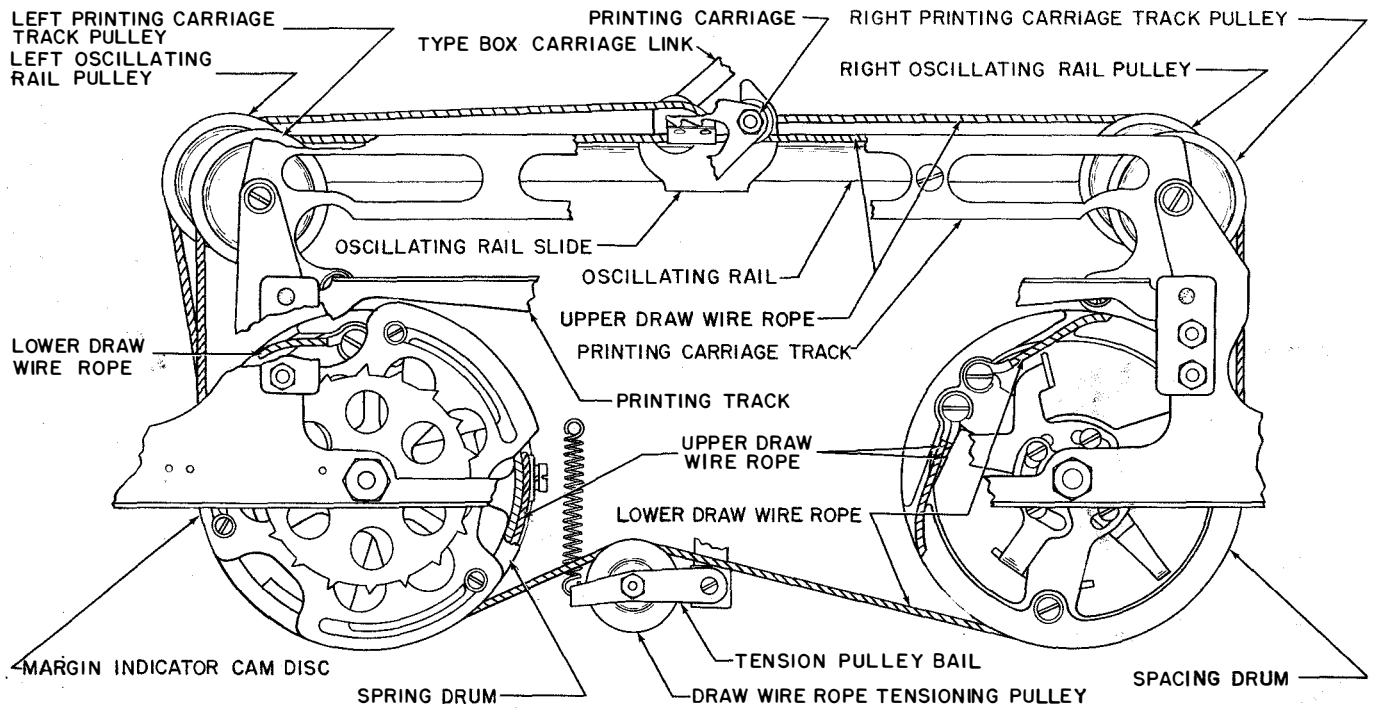


Figure 2-44. Draw Wire Rope Mechanism

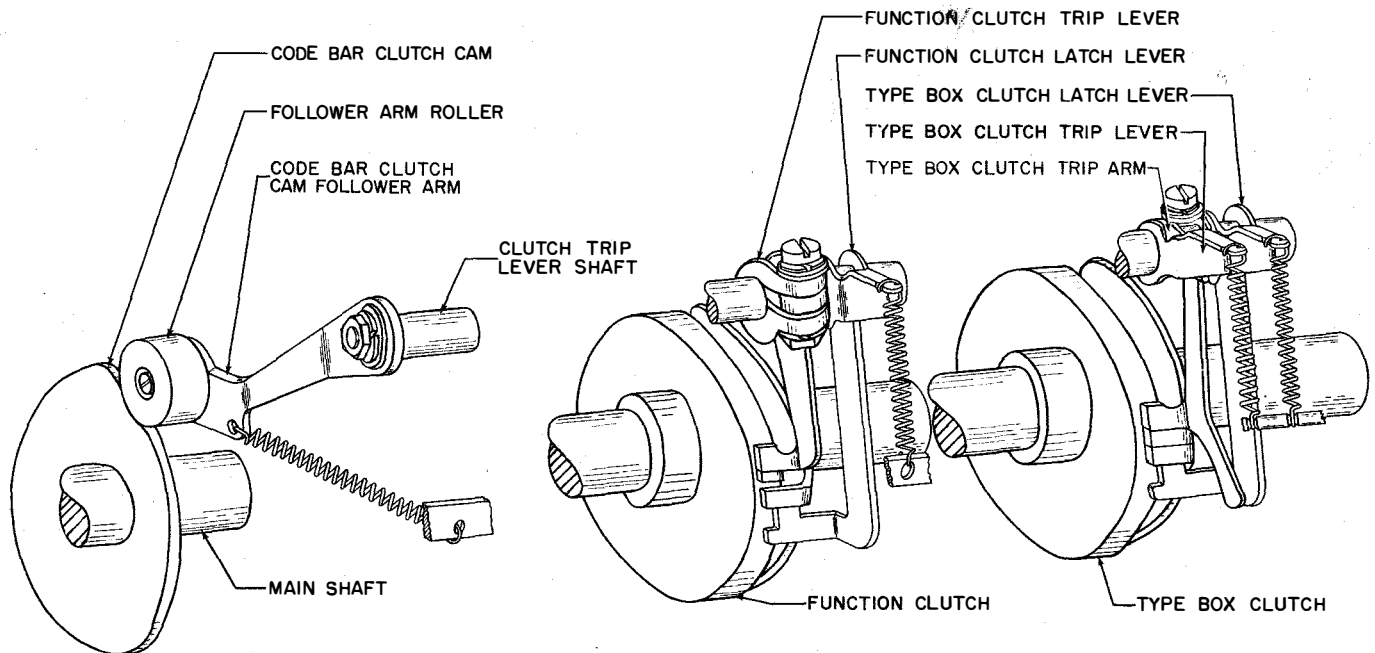


Figure 2-45. Trip Mechanism For Function and Type Box Clutches

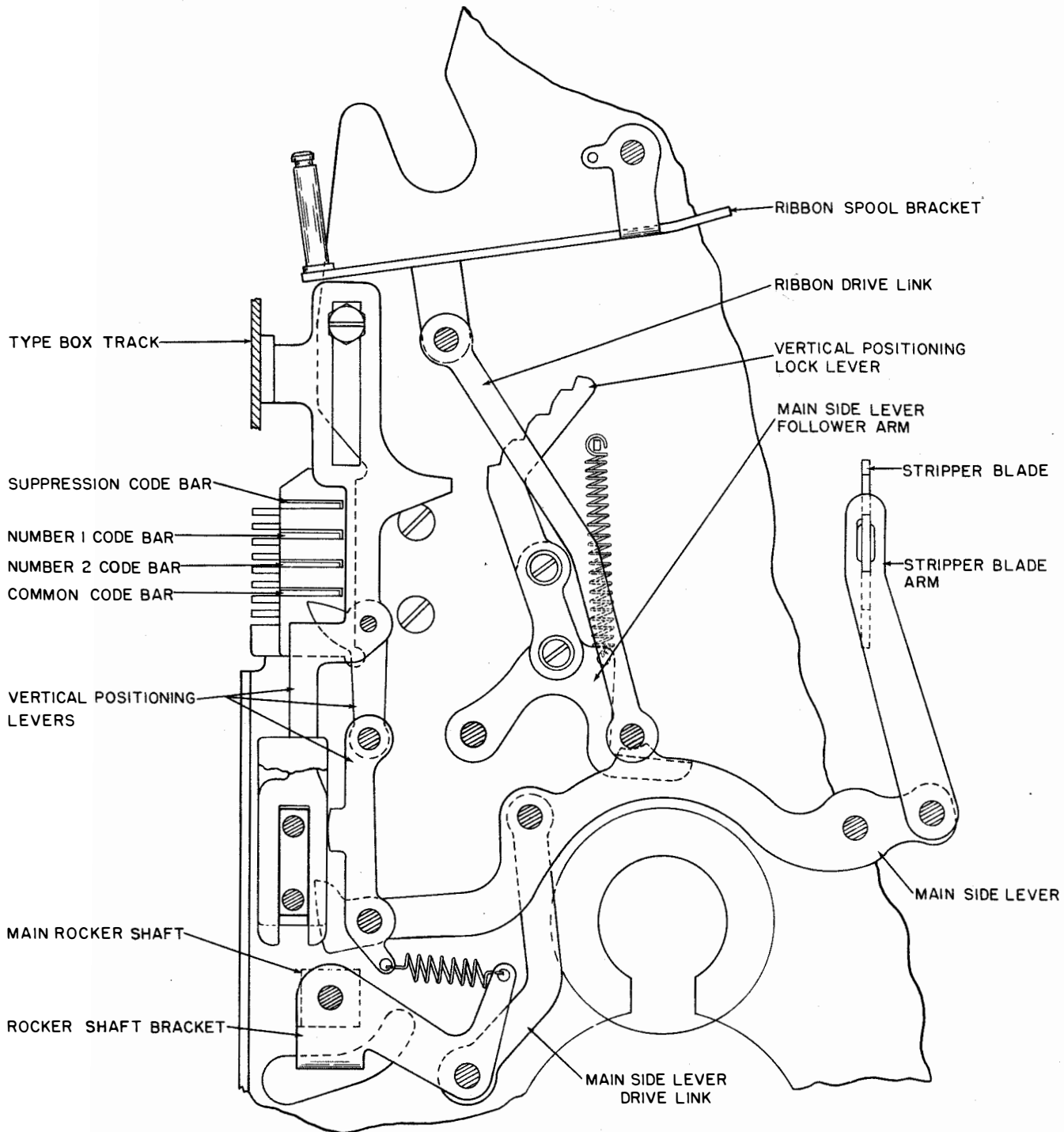


Figure 2-46. Right Side Mechanism

code bar is toward the right (spacing), the common code bar is toward the left. The number 2 code bar blocks the vertical positioning levers, and the second row of pallets in the type box are then in line for printing. When the number 1 code bar is toward the right (spacing), and the number 2 code bar is toward the left (marking), the common code bar is toward the left.

The number 1 code bar blocks the vertical positioning levers, and the third row of pallets in the type box are then in line for printing. When the number 1 and number 2 code bars are toward the left (marking), the common code bar is also toward the left. The suppression code bar blocks the vertical positioning levers, and the fourth or bottom row of pallets in the type box are



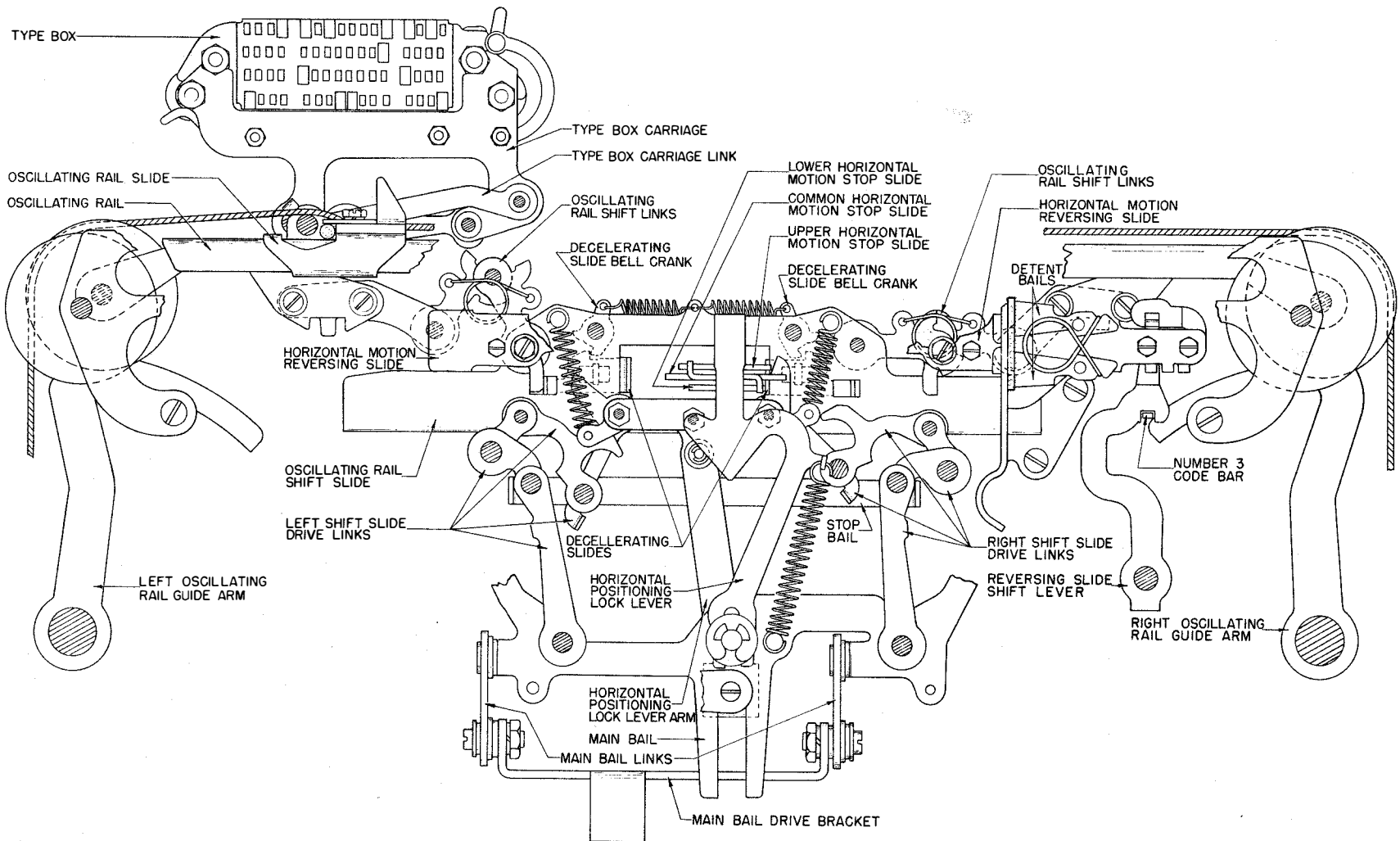


Figure 2-47. Front Plate Horizontal Positioning Mechanism

ORIGINAL

then in line for printing. At each of the four levels at which the vertical positioning levers may be stopped, they are locked momentarily by lock levers which are controlled by the main side lever follower arms.

3. A bracket attached to the main rocker shaft applies vertical motion to the main bail by means of two links (figure 2-47). Attached to each end of the oscillating rail shift slide, are pivoted "buckling" type drive links which extend downward to each end of the main bail. As the main bail moves downward, the left drive links if not buckled, will try to shift the oscillating rail shift slide toward the right while the right drive links, if not buckled, will try to shift the oscillating rail shift slide toward the left. When the number 3 code bar is shifted toward the left (marking), the horizontal motion reversing slide is shifted toward the left by its shift lever, and is held there by detent bails. A projection near the right end of the reversing slide will then make contact with the right oscillating rail shift slide drive links and cause them to buckle. As the main bail is driven downward, the unbuckled left shift slide drive links will start to shift the rail shift slide toward the right. This positions the type box so that the character to be printed will be found in the left half of the LETTERS or FIGURES end. In a similar manner, when the number 3 code bar is shifted toward the right (spacing) the horizontal-motion reversing slide is also shifted toward the right by its shift lever, and is held there by the detent bails. A projection near the left end of the reversing slide then makes contact with the left oscillating rail shift slide drive links and causes them to buckle. As the main bail is driven downward, the unbuckled right shift slide drive links will start to shift the rail shift slide toward the left. This positions the type box so that the character to be printed will be found in the right half of the LETTERS or FIGURES end.

4. After it has been thus determined in which side the character to be printed is located, the number 4 and number 5 code bars operate three horizontal-motion stop slides to determine in which of the four vertical rows in that side the character is to be found. A wedge shaped horizontal-positioning lock lever which is pulled downward by the main bail through a yield spring, bears against the horizontal positioning lock lever arm. This arm drives the oscillating rail shift slide in the direction in which it was started (by the number 3 code bar selection) until one of the decelerating slides which are fastened to the oscillating rail shift slide strikes an unselected horizontal motion stop slide. A camming surface on the unbuckled drive links makes contact with and rolls down the face of the decelerating slide and causes the drive links to buckle. The oscillating rail shift slide finally comes to rest when it strikes the blocked decelerating slide. This in turn ends the downward

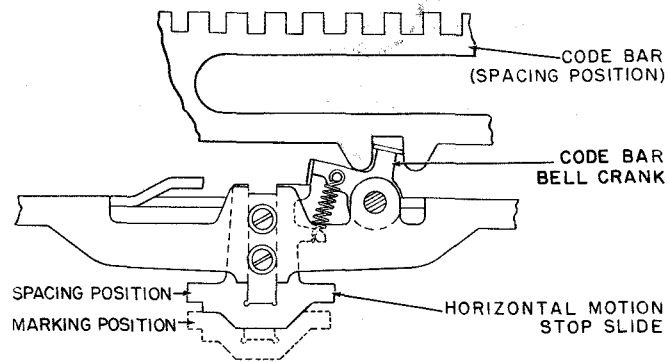


Figure 2-48. Stop Slide Positioning

excursion of the lock lever, and the yield spring extends until the main bail reaches the lowest point of its oscillation. As the main bail returns upward, it centers the oscillating rail shift slide. It is during this time that the horizontal motion stop slides are positioned for the selection of the next character. The number 4 and number 5 code bars each operate a code bar bell crank. Each, in turn, moves a horizontal-motion stop slide toward the front (marking), or toward the rear (spacing) (figure 2-48). A third (common) stop slide (spring tensioned toward the rear) is located between the upper and lower stop slides and has projections which pass across the front edges of these slides (figure 2-47). Each stop slide is of a different length. The common slide which is the longest stop has an additional step on its shank so that it serves as the shortest stop when all the slides are moved forward. The upper slide (operated from the number 4 code bar) is the second longest stop, and the lower slide (operated from the number 5 code bar) is the third longest stop.

5. When both the number 4 and number 5 code bars are toward the right (spacing), their respective horizontal-motion stop slides and the common stop slide are toward the rear. The oscillating rail shift slide is moved to the right or left of its central position (determined by the number 3 code bar) until it is stopped by one end of the common horizontal-motion stop slide. This positions the first vertical row (right or left of FIGURES center or LETTERS center) in line for printing. When the number 4 code bar is toward the right (spacing), and the number 5 code bar is toward the left (marking), the upper and the common stop slides are toward the front, and the lower stop slide is toward the rear. The oscillating rail shift slide is moved to the right or left of its central position until it is stopped by one end of the upper stop slide. This positions the second vertical row (right or left of FIGURES center or LETTERS center) in line for printing. When the number 4 code bar is toward the right (spacing), and the number 5 code bar is toward the left

(marking), the upper stop slide is toward the rear and the lower and the common stop slides are toward the front. The oscillating rail shift slide is moved toward the right or left of its central position until it is stopped by one end of the lower stop slide. This positions the third vertical row (right or left of FIGURES center or LETTERS center) in line for printing. When both the number 4 and number 5 code bars are toward the left (marking), their respective horizontal-motion stop slides and the common stop slide are toward the front. The oscillating rail shift slide is moved toward the right or left of its central position until it is stopped by one side of the shank of the common stop slide. This positions the fourth vertical row (right or left of FIGURES center or LETTERS center) in line for printing.

### (3) PRINTING HAMMER AND PRINTING CARRIAGE.

(a) GENERAL.—After the type box has been moved so that the selected type pallet is in its proper position, it must be struck by a printing hammer in order to print. This is accomplished by the action of the printing carriage located on the printing carriage track.

(b) POSITIONING.—The printing carriage rides (on rollers) on the printing carriage track which is rigidly attached to the automatic typer front plate. The carriage is clamped to the forward section of the upper draw wire rope. This moves the carriage along its track in such a manner that the hammer advances to the next printing position.

(c) PRINTING.—The printing track which is located on the front of the Automatic Typer (figure 2-49) is fastened to an extension at each end of the main bail. As the main bail reciprocates vertically, it extends the motion to the printing track which travels in guides located at each end of the track. The printing arm which extends downward from the printing carriage, rides the printing track. As the arm follows the reciprocating motion of the track, its upper end moves first toward the left and then toward the right. When the upper end of the arm moves toward the left, it rotates the printing hammer operating bail clockwise against its spring tension until it becomes latched by the operating bail latch (figure 2-50). The printing hammer operating bail draws the printing hammer bail away from the type box by means of the printing hammer bail spring. When the upper end of the printing arm moves to its extreme right position, it makes contact with the latch and causes it to release the printing hammer operating bail. The operating bail is swung in a counterclockwise direction by the operating bail spring until it strikes its stop. The printing hammer bail, in being driven by the operating bail, is swung toward the type box. When the operating bail is stopped, momentum causes the

printing hammer bail to continue its travel against the tension of the printing hammer bail spring until the printing hammer strikes the selected type pallet.

### f. SPACING.

(1) GENERAL.—To properly space the printed character, the type box and printing carriages must be advanced with each character printed. As was shown in paragraph 4.e.(2)(a) of this section and figure 2-44, the carriages are connected to a draw wire rope which, in turn, is fastened to the spring drum and spacing drums. The purpose of the spring drum which contains a torsion spring is to tension the draw wire rope and thus the carriage to the left. The spacing drum has ratchet teeth about its perimeter which are engaged by the eccentric driven spacing drum feed pawls (figure 2-51). The spacing shaft which mounts the spacing eccentrics is driven, through its helical gear, by the helical driving gear attached to the three stop spacing clutch on the main shaft. The gear ratio of  $1\frac{1}{2}$  to 1 causes the spacing shaft to turn one-half of a revolution each time the spacing clutch is tripped. This allows the feed pawls to advance the spacing drum by the amount of one ratchet tooth. As shown earlier, each time the Automatic Typer operates, the main rocker shaft is made to oscillate about its center. A cam plate which is fastened to the lower side of the rocker shaft is in its lowest position during the rest time. During the time that printing is to take place, the cam plate is moved upward by the shaft and operates the spacing trip lever bail. As this bail is rotated about its pivot point, it raises the spacing trip lever until it latches onto the spacing clutch trip lever arm (figure 2-52). As the rocker shaft reverses its direction of rotation, the spacing trip lever bail and trip lever move downward thus causing the latched up spacing clutch trip lever arm to operate the spacing clutch trip lever and release the spacing clutch. Before the spacing clutch completes one-third of a revolution, its restoring cam moves the spacing trip lever about its pivot point until it releases the spacing clutch trip lever arm. This, in turn, releases the spacing clutch trip lever which returns to its normal position in time to stop the spacing clutch after one-third of a revolution. The spacing clutch three-stop cam disk has indents at each stop position. The spacing clutch latch lever follows this cam disk and is thereby held away from the clutch drum until one of the three lugs on the clutch shoe lever disk passes under the latch lever and is stopped by the function clutch trip lever. Due to its inertia the three-stop clutch cam disk continues to turn until its lug makes contact with the lug on the clutch shoe lever. At this point the latch lever drops into the indent in the cam disk, and the clutch is held disengaged until the trip lever is again operated.

(2) SPACING SUPPRESSION.—When certain

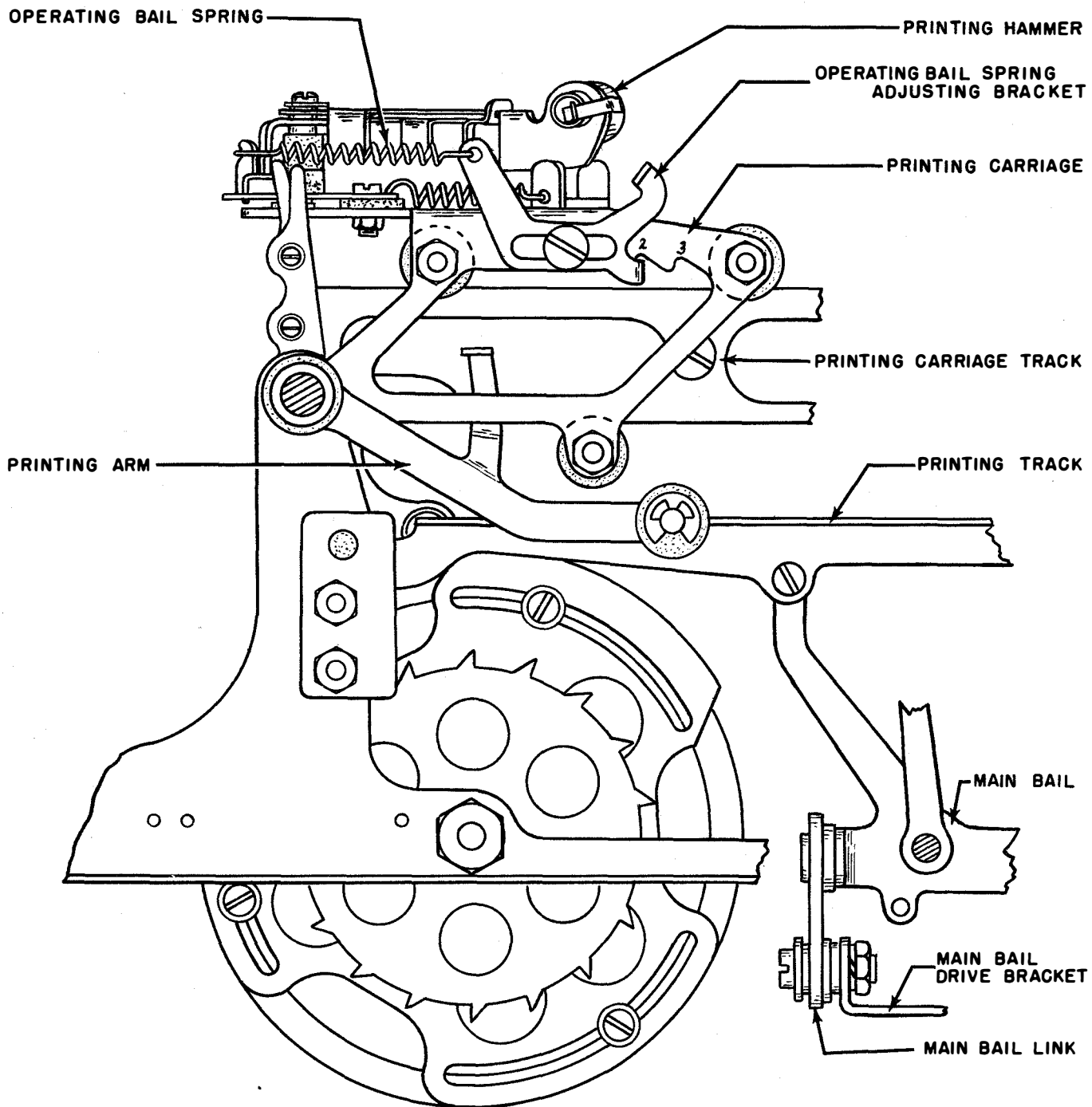
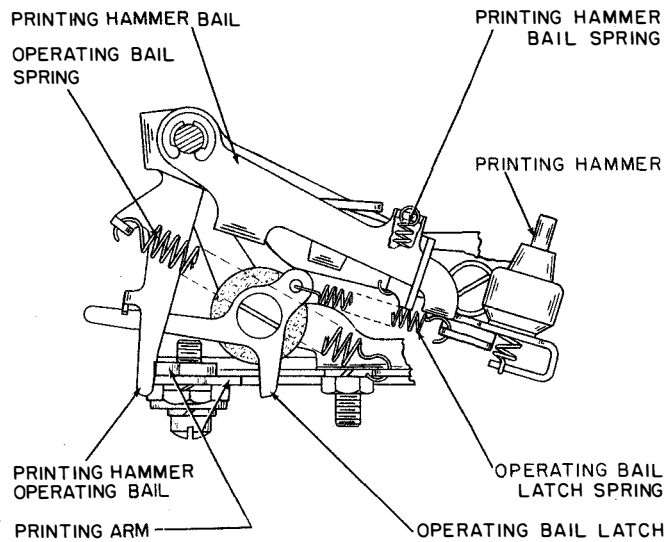


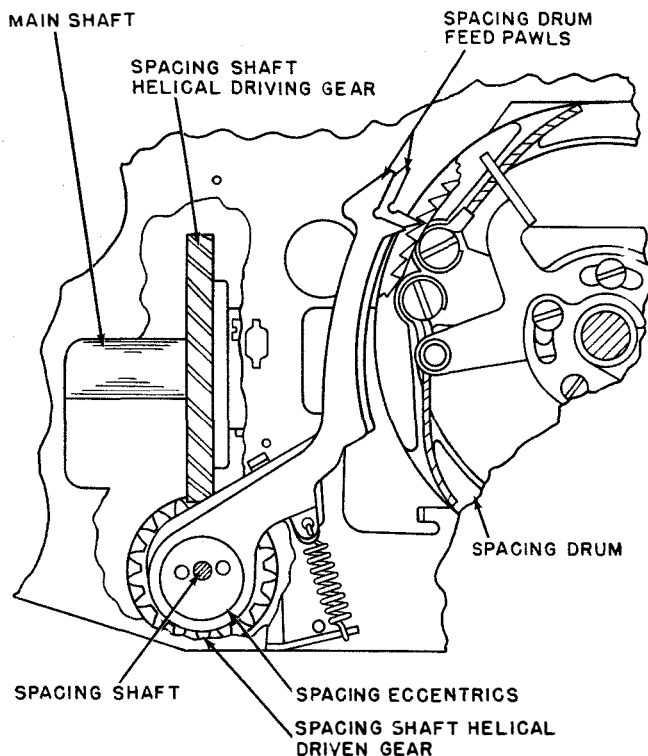
Figure 2-49. Printing Hammer Mechanism, Front View

functions are selected or when the carriages reach their extreme right position, it is necessary to suppress spacing. This is accomplished by moving the spacing suppression slide forward. In this position, it will hold the upper end of the spacing trip lever forward and prevent it from engaging the spacing clutch trip lever arm. In the case of spacing suppression on functions, the spacing suppres-

sion slide is shifted by means of the spacing suppression bail. The manner in which this bail is operated will be discussed under functions. When the carriages have reached their extreme right position, a spacing cut-out lever on the spacing drum, engages the spacing cut-out transfer bail (figure 2-53), which in turn operates the spacing cut-out bail. The spacing cut-out bail shifts the



**Figure 2-50. Printing Hammer Mechanism, Top View**



**Figure 2-51. Spacing Drum Drive Mechanism**

spacing suppression slide and prevents spacing until the carriages are returned.

**g. MARGIN INDICATOR.**

(1) Before the type box and printing carriages reach the end of their travel, a margin indicator light

I-751 on the cabinet is illuminated. The contact mechanism which controls the lamp circuit is mounted on the Keyboard and is fully described in paragraph 3.k. of this section. The actuator of this contact mechanism is a disk which is mounted on the spring drum of the Automatic Typewriter (figure 2-44). The angular position of this cam disk with respect to the spring drum may be altered to change the point at which the indicator will light.

**b. RIBBON MECHANISM.**

(1) POSITIONING.—The left and right ribbon feed mechanism oscillates in a vertical plane with each revolution of the type box clutch. They are driven by ribbon drive links which are attached to the main side levers (figure 2-54). At its uppermost position, the ribbon mechanism positions the ribbon relative to the line which is being printed. After each character is printed, the ribbon mechanism is dropped downward (dashed outlines, figure 2-54), together with the type box, in order that the last character printed may be viewed. The ribbon is held in place at the point of printing by a ribbon guide which is fastened to the rear of the type box carriage.

(2) FEEDING.—Each of the ribbon spool brackets has a ribbon ratchet wheel attached to the shaft on which the ribbon spool is mounted. The ribbon spool bracket (which supports the ribbon ratchet wheel, the ribbon spool shaft, the ribbon roller, and the ribbon lever) pivots about point A in figure 2-54. The inner and outer ratchet feed levers pivot about point B, and are held against the ribbon ratchet wheel by their springs. As the ribbon drive link moves the ribbon spool bracket upward, the outer ratchet feed lever engages the ratchet teeth and pulls the ratchet wheel (figure 2-55). The inner ratchet feed lever skips over the saw tooth shaped teeth. As the ribbon drive link moves the ribbon spool bracket downward, the inner ratchet feed lever engages the ratchet teeth and pushes the ratchet wheel. The outer ratchet feed lever skips over the teeth. The teeth on the left and right ribbon ratchet wheels face in opposite directions so that, when their feed levers are engaged, the left ribbon spool turns clockwise, and the right ribbon spool turns counterclockwise. In order for the ribbon to feed from one spool to the other, only one set of inside and outside ratchet feed levers may engage their ribbon ratchet wheel at a time. Also, when the ribbon has become completely unwound from one spool, it is necessary to reverse its direction so it can rewind. This is accomplished automatically by disengaging one set of ratchet feed levers and engaging the other set. While the ribbon is passing from the left spool to the right spool, the right set of ratchet feed levers are engaged. The left set are held disengaged against the pull of their springs by the left ribbon feed

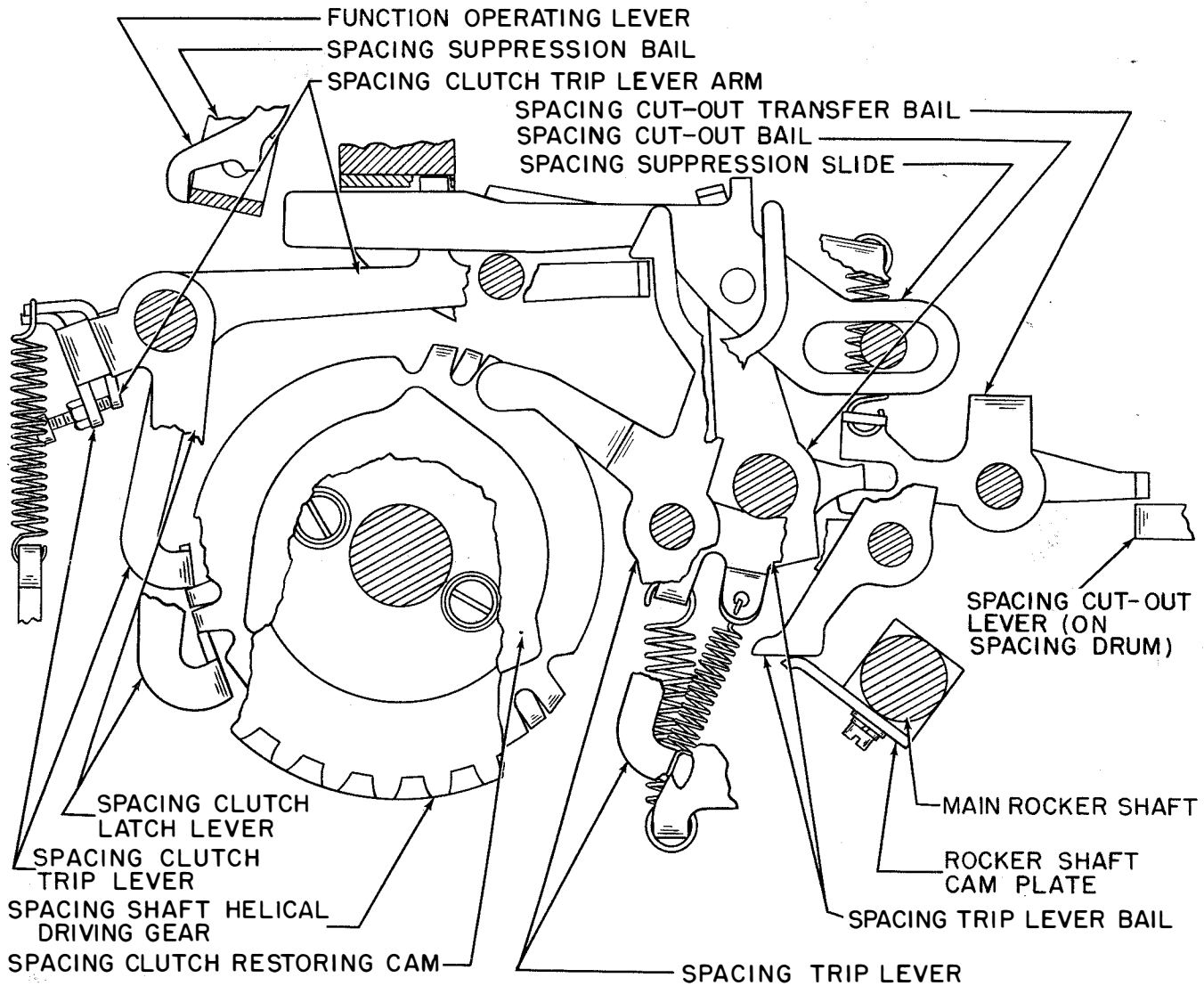


Figure 2-52. Spacing and Spacing Suppression Mechanism

reverse lever which is in its down position (figure 2-56). The lever is held in this position by the ribbon reverse detent lever that acts on the ribbon reverse detent cam on the ribbon reverse shaft to lock the spur gears which engage the ribbon reversing levers. As the ribbon, which passes around the ribbon roller and through the slot in the end of the ribbon lever nears its end, an eyelet which is fastened to it catches in the ribbon lever slot, and pulls the lever toward the right. The next time the ribbon drive link moves the ribbon spool bracket upward the ribbon lever which is also moved upward engages the end of the left ribbon reversing lever and causes it to move to the dashed position shown in figure 2-56. As the lever moves, its teeth rotate the left spur gear which, through the ribbon reverse shaft, turns the detent cam and the right spur gear. The right spur gear moves the right ribbon reversing lever downward while

the pin on the lever drives the right ribbon feed reverse lever downward so that it holds the right set of ratchet feed levers disengaged. At the same time, the pin on the left ribbon reversing lever moves the left ribbon feed reverse lever upward so that the left set of ratchet feed levers can engage their ratchet wheel. Thus, the ribbon is rewound on the left spool. When it nears its end on the right spool, the ribbon again reverses in a manner similar to that just described.

i. FUNCTIONS.

(1) GENERAL.

(a) There are two types of operations which can be performed by the Automatic Typewriter. The first embodies those mechanical actions which are directly necessary to the actual printing of a character. The second embodies mechanical action which is supple-

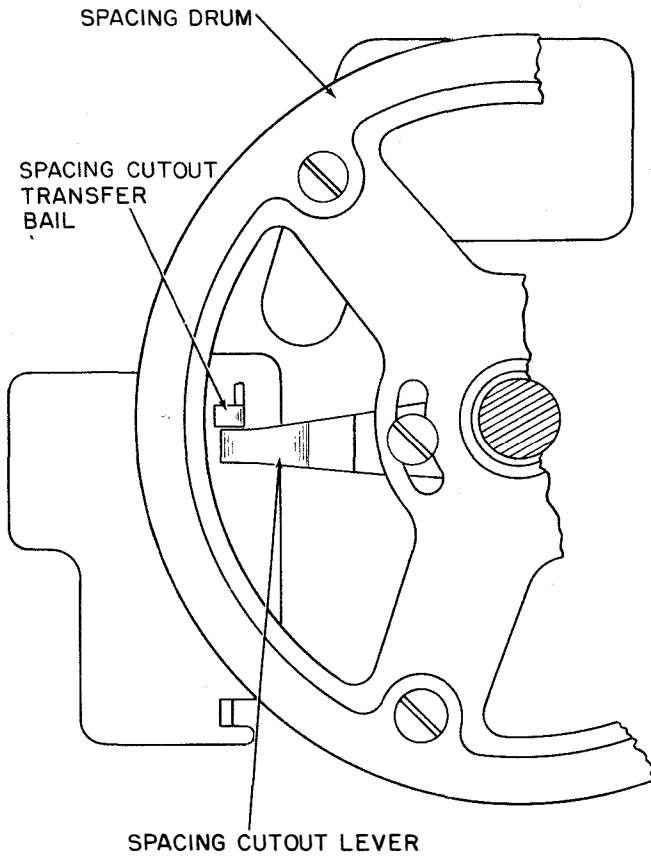


Figure 2-53. Spacing Cutout Mechanism

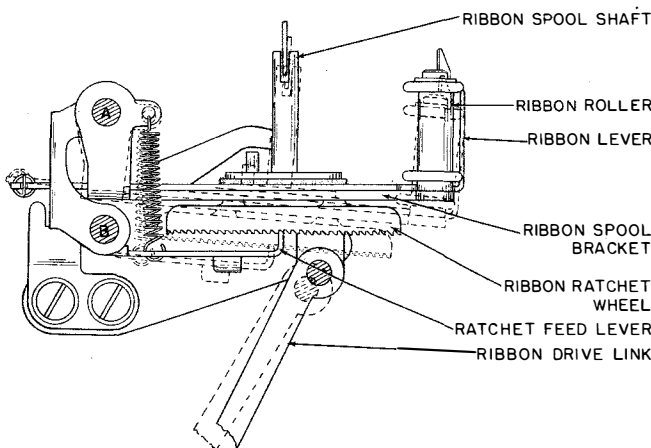


Figure 2-54. Ribbon Mechanism, Left Side

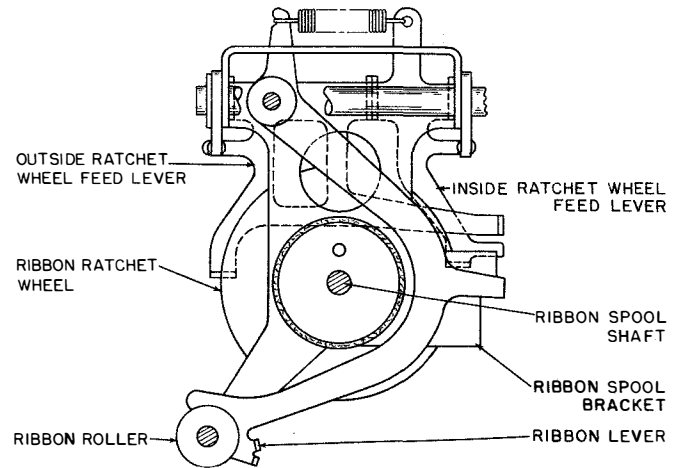


Figure 2-55. Ribbon Mechanism, Left Top View

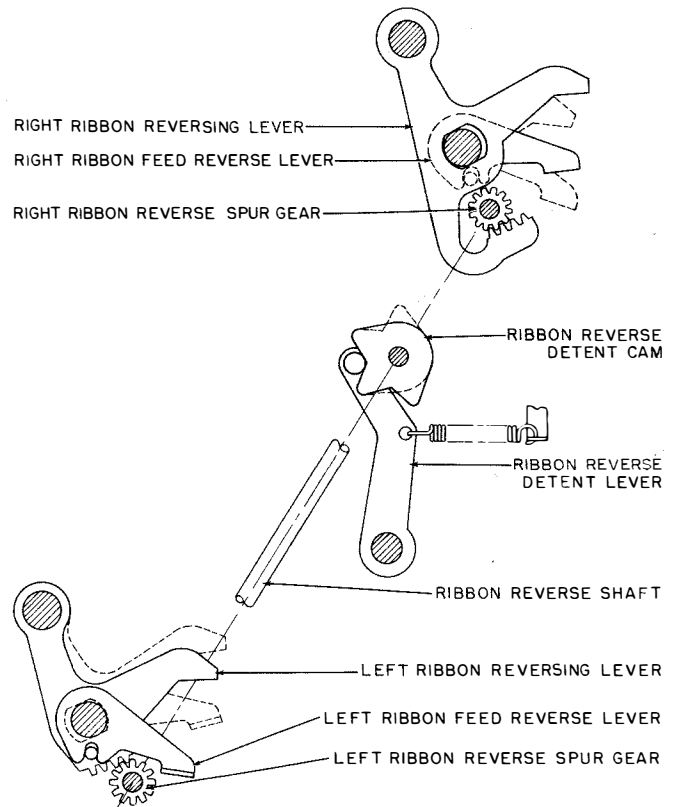


Figure 2-56. Ribbon Reversing Mechanism

mentary to the printing of a character, or which alters the positions of the various mechanisms and is known as a function.

(b) As in printing, the reception of function codes results in the positioning of the code bars the back edges of which are notched. Positioned directly behind

the code bars is a function box, which contains the function bars for the various functions (figure 2-57). Each function bar has a series of lugs on its end which are offset to one side or the other to correspond with the marking and spacing elements of the particular code to which it is to respond. When the two-stop function

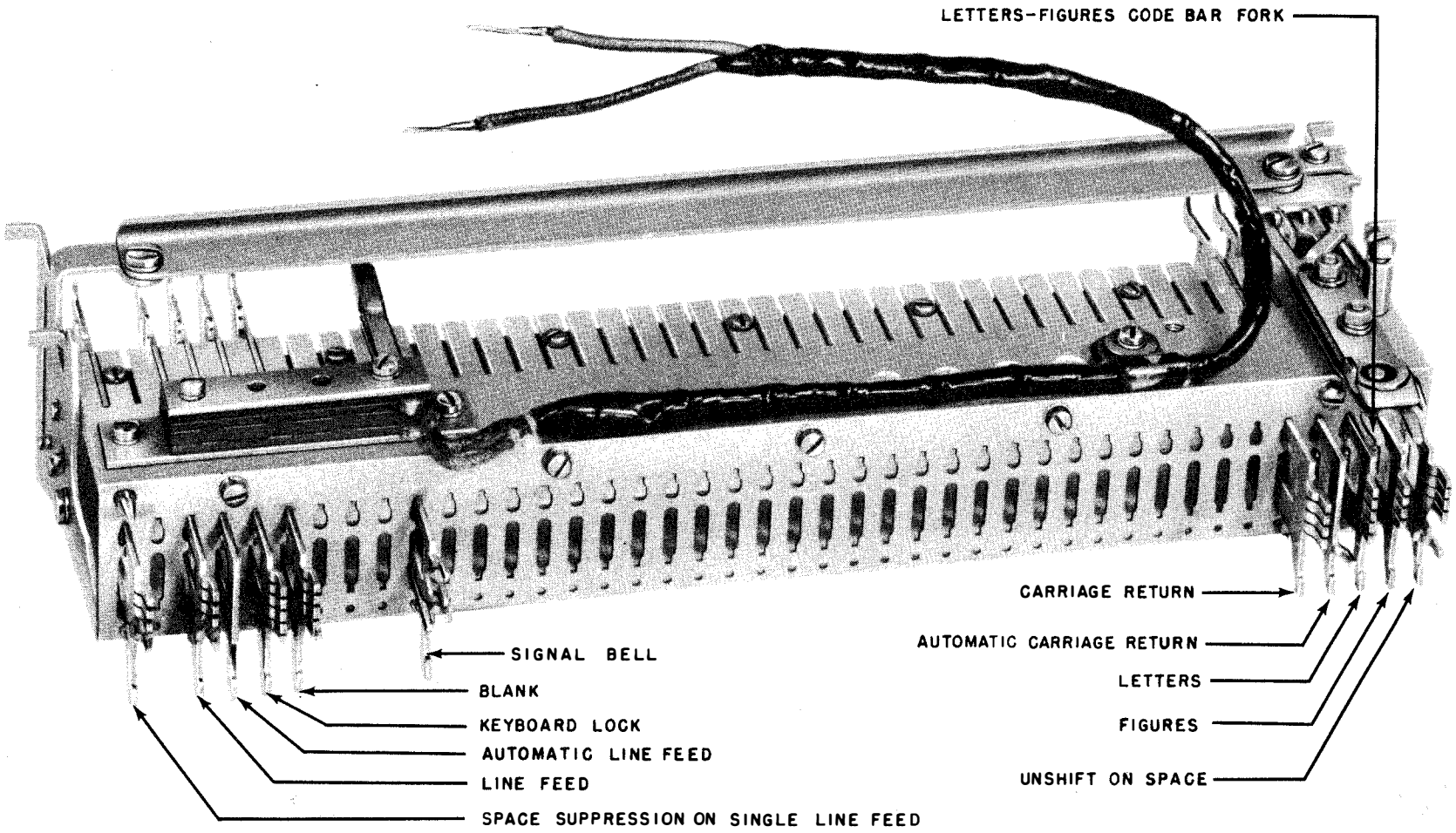


Figure 2-57. Function Box, Front View Showing Function Bars



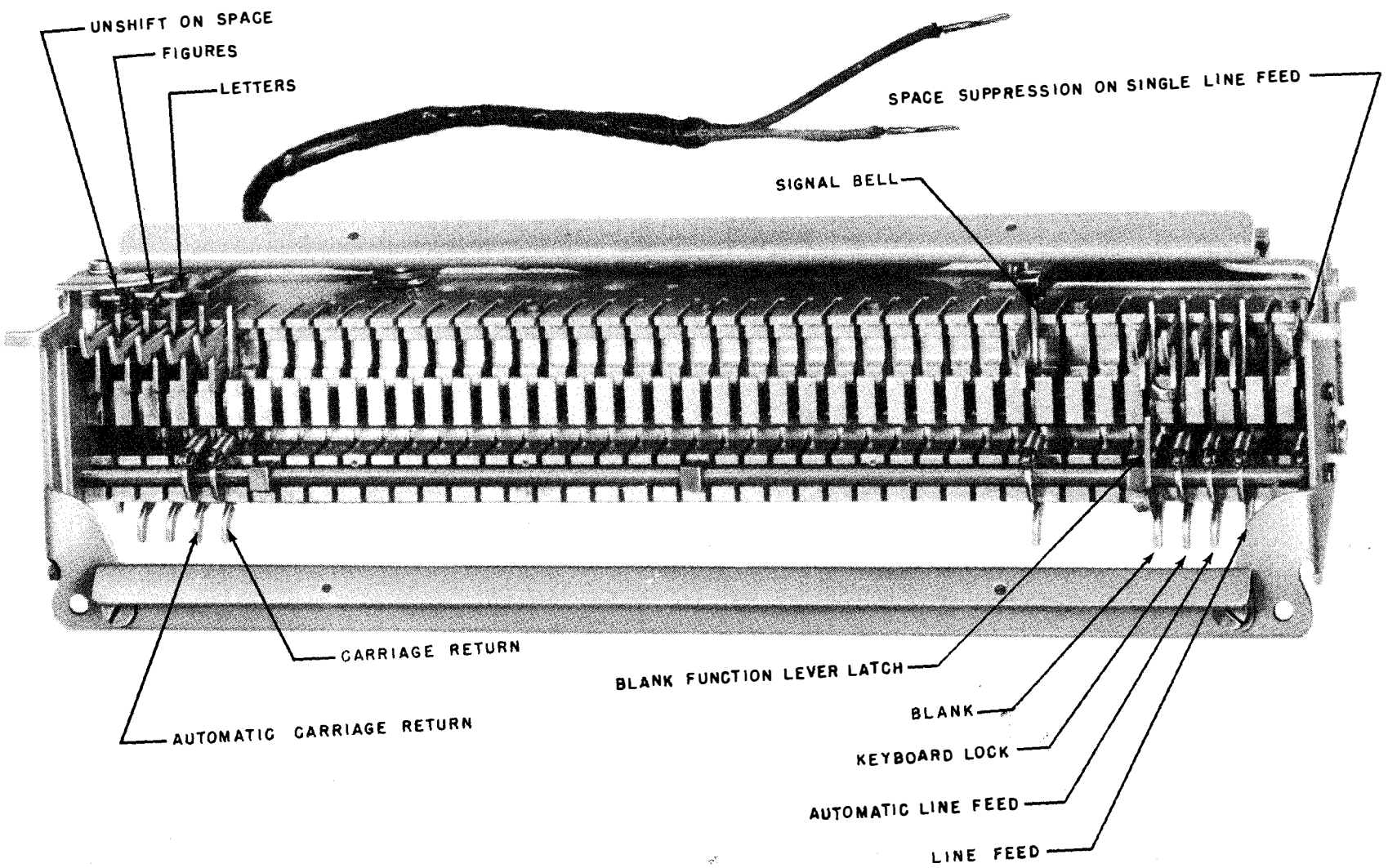
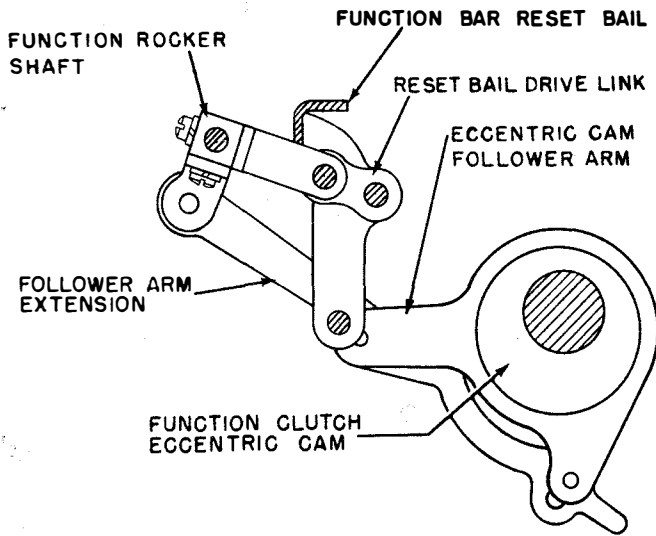


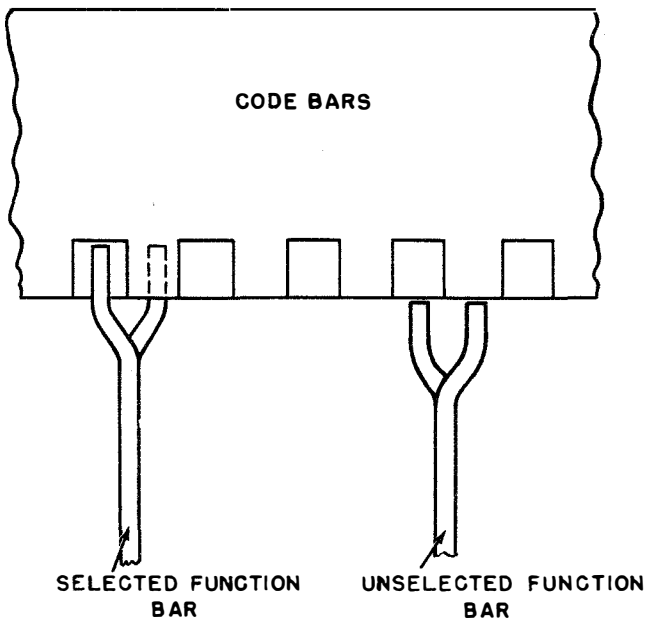
Figure 2-58. Function Box, Rear View Showing Function Levers

ORIGINAL

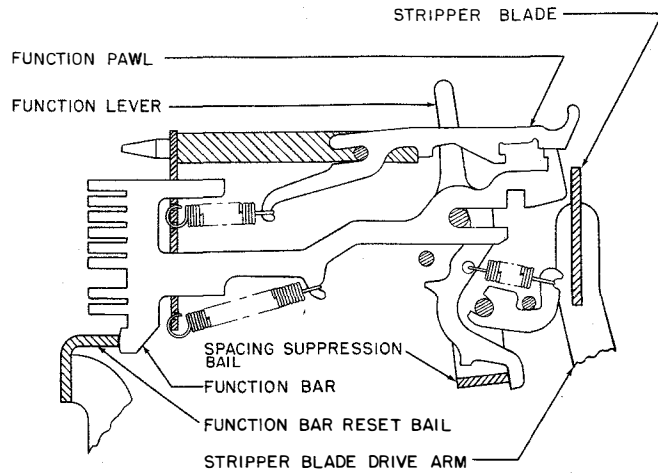


**Figure 2-59. Function Reset Bail Mechanism**

clutch is tripped (paragraph 4.e.(2)(b)2. of this section, and figure 2-45), it rotates one-half of a revolution. During this time it extends motion to the code bar reset bail through the intervening cam and follower arm, follower arm extension, function rocker shaft, and reset bail drive links, to cause the reset bail to release the function bars momentarily (figure 2-59). As the spring tensioned function bars are released, they move forward to make contact with the code bars. If the code bars are positioned for a function, each lug on the function bar for that function will be opposite a slot in a code bar. This will permit the selected function bar to

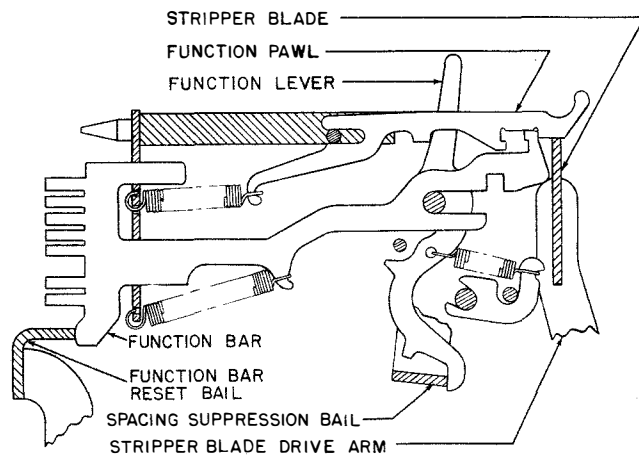


**Figure 2-60. Function Selection, Top View**



**Figure 2-61. Typical Function Box Mechanism, Unselected**

move forward into the code bars while the other function bars are blocked by one or more code bars (figure 2-60). Associated with each function bar in the function box, is a function pawl and a function lever. In the unselected position, a function bar is not latched with its function pawl (figure 2-61). When the function bar reset bail releases the function bars, any bar which may be selected will move sufficiently far forward (to the left in the figure) to permit it to engage its function pawl. Then, as the reset bail returns the function bar to its initial position, the function bar carries the function pawl to the rear (to the right in figure 2-62). The function pawl, in turn, moves the function lever clockwise about its pivot point. A projection at the lower end of most function levers operates the spacing suppression bail (paragraph 4.f.(2) of this section) and either the upper or lower ends of the levers operate the various functions. Near the completion of the func-



**Figure 2-62. Typical Function Box Mechanism, Selected**

tion cycle, a stripper blade (operated by the main side levers through the stripper blade arm, figure 2-46), rises to engage any selected function pawl and strip it from its function bar. Springs return the released function pawl and function lever to their original position (figure 2-16). It should be noted here that, to prevent printing during the function cycle, whenever a function selection occurs the type box is positioned such that the printing hammer will strike where there is no type pallet. The function clutch two-stop cam disk has indents at both stop positions. The function clutch latch lever follows this cam disk and is thereby held away from the clutch drum until one of the two lugs on the clutch shoe lever disk passes under the latch lever and is stopped by the function clutch trip lever. Due to its inertia, the two-stop clutch cam disk continues to turn until its lug makes contact with the lug on the clutch shoe lever. At this point the latch lever drops into the indent in the cam disk, and the clutch is held disengaged until the trip lever is again operated.

(2) LETTERS AND FIGURES SHIFT FUNCTION.

(a) The letters and figures function bars, pawls and levers which are located near the right end of the function box operate on letters and figures codes respectively. The upper ends of the function levers engage the letters and figures function slides (figure 2-63 and 2-64). The front ends of these function slides have camming surfaces which, when a slide is shifted to the rear by its function lever, move the letters-figures code bar fork to the right (LETTERS position—figure 2-63) or to the left (FIGURES position—figure 2-64). The letters-figures code bar fork engages a pin on the bracket which is fastened to the letters-figures shift code bar, and positions the code bar toward the right for LETTERS function or toward the left for FIGURES function (figure 2-65). A slotted extension of the code bar engages a tongue on the letters-figures shift slide and causes the shift slide to follow the movements of the code bar. Pins at the ends of the shift slide serve as lower guides for the right and left shift link breaker slides. Pins which project from the front plate serve as upper guides and pivot points. Mounted on the ends of the main bail are the left and right breaker slide bails. When the letters function code is received, the shift slide is shifted to the right as shown. This places the left shift link breaker slide in a vertical position with its lower end over the left breaker slide bail. The right breaker slide is positioned such that its lower end is to the right of the right breaker slide bail. As the main bail moves upward, the right breaker slide bail clears the right breaker slide while the left breaker slide bail engages the left breaker slide and moves it upward. This action causes the left oscillating rail shift links to break and shift the oscillating rail to the right for the printing of LETTERS

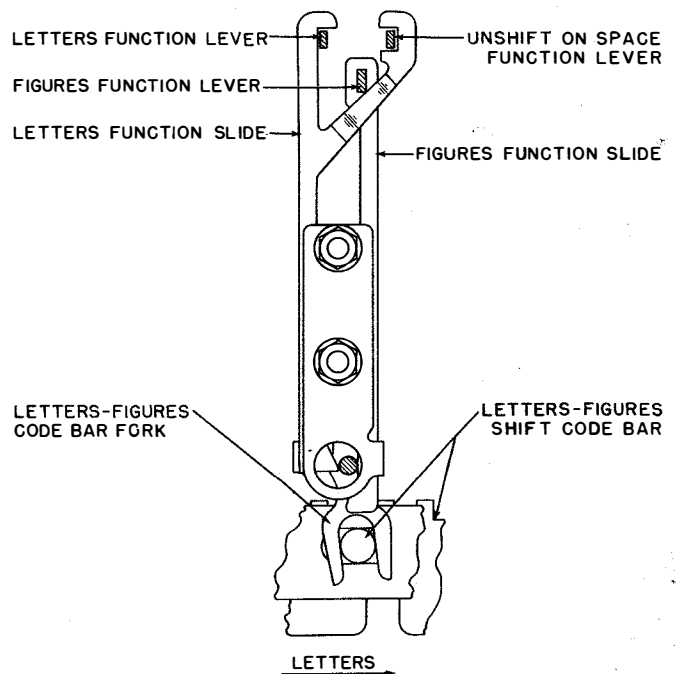


Figure 2-63. Letters-Figures Function Slides, Letters Position

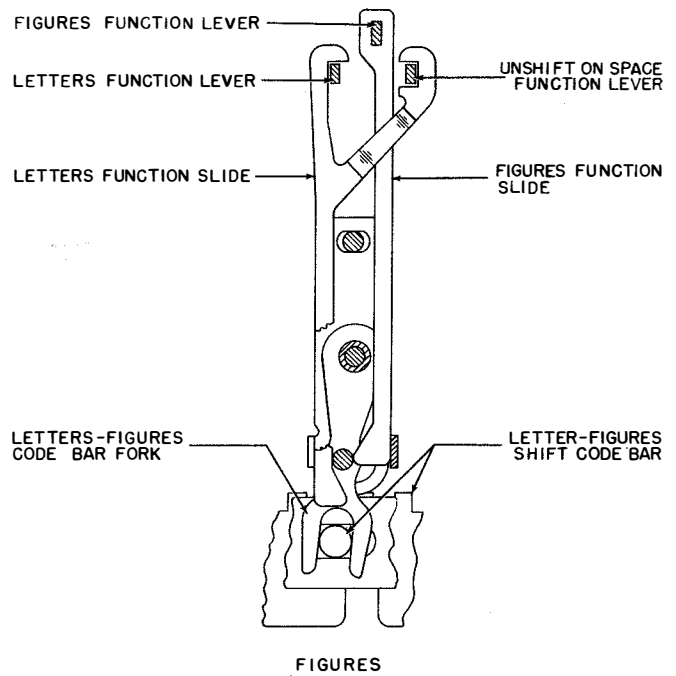


Figure 2-64. Letters-Figures Function Slides, Figures Position

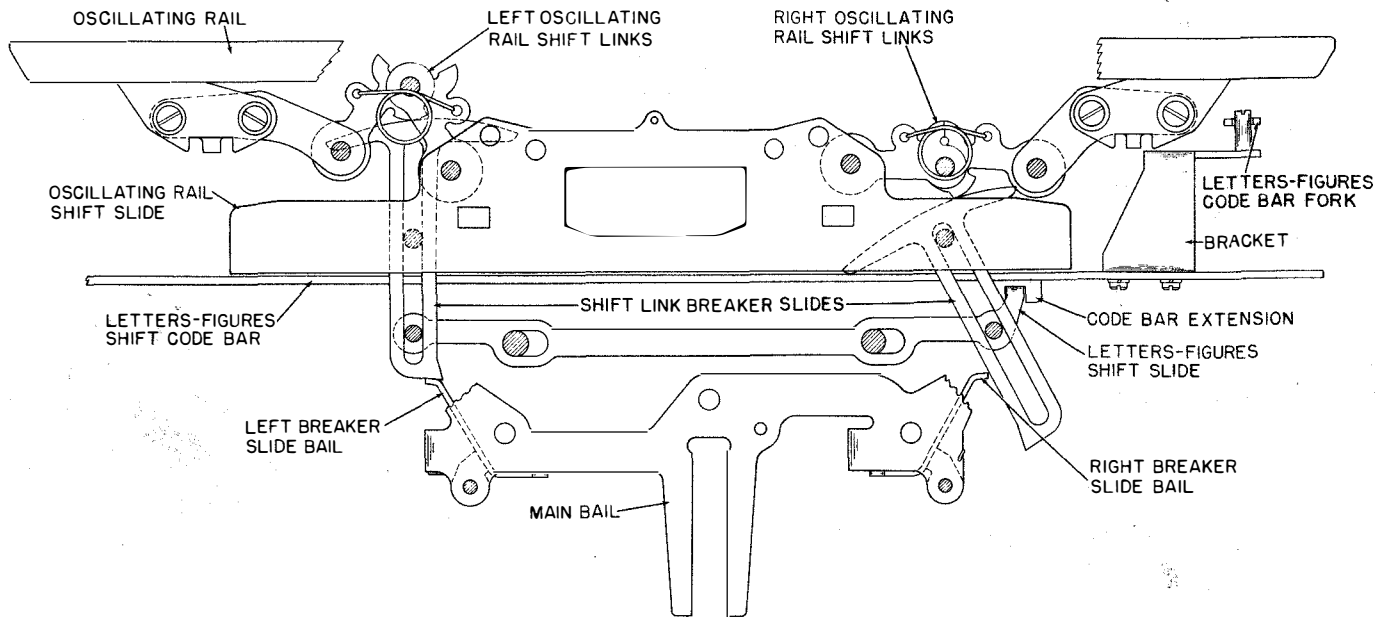


Figure 2-65. Letters-Figures Shift Mechanism, Letters Position

characters. In a similar manner, when figures function code is received the right oscillating rail shift links are broken and the rail is shifted to the left for the printing of FIGURES characters.

(3) SPACING FUNCTION.

(a) SPACING.—For spacing between words or any spacing other than that which accompanies printing, the operator uses the space bar which is attached to the space keylever on the Keyboard. The function operates in the manner described under Spacing, paragraph 4.f.(1) of this section. However, as in all the functions printing does not occur.

(b) UNSHIFT ON SPACE.—A function bar which operates on spacing code is located at the right end of the function box. Its associated function lever engages an extension of the letters function slide (figure 2-66). Thus, whenever a spacing function occurs, letters shift will take place in the manner described in paragraph 4.i.(2). The projection at the lower end of the spacing function lever is removed in order not to operate the spacing suppression bail which would suppress spacing. When it is undesirable to use the unshift on space feature, the mechanism may be disabled. This is accomplished by turning a screw (located over the front end of the function pawl) downward until the rear end of the pawl is raised to clear the function bar.

(4) CARRIAGE RETURN FUNCTION.

(a) The carriage return function mechanism is located in the right end of the Automatic Typewriter. The reception of the carriage return code causes the carriage return function bar, pawl, and lever to operate (figure

2-67). The lower end of the function lever engages the carriage return slide arm and pushes it forward (toward the left in the figure). The slide arm, in turn, moves the carriage return bail and its lever about their pivot point. As the front portion of the lever moves downward, it takes with it the lower section of the spacing drum feed pawl release link. This causes the upper portion of the link to turn and disengage the spacing drum feed pawls from the spacing drum (figure 2-68). When the car-

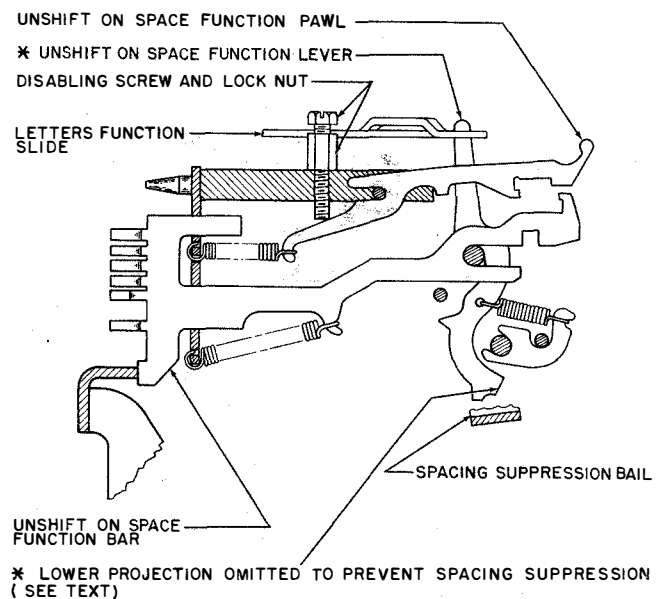


Figure 2-66. Unshift On Space Function Mechanism, Disabled Position

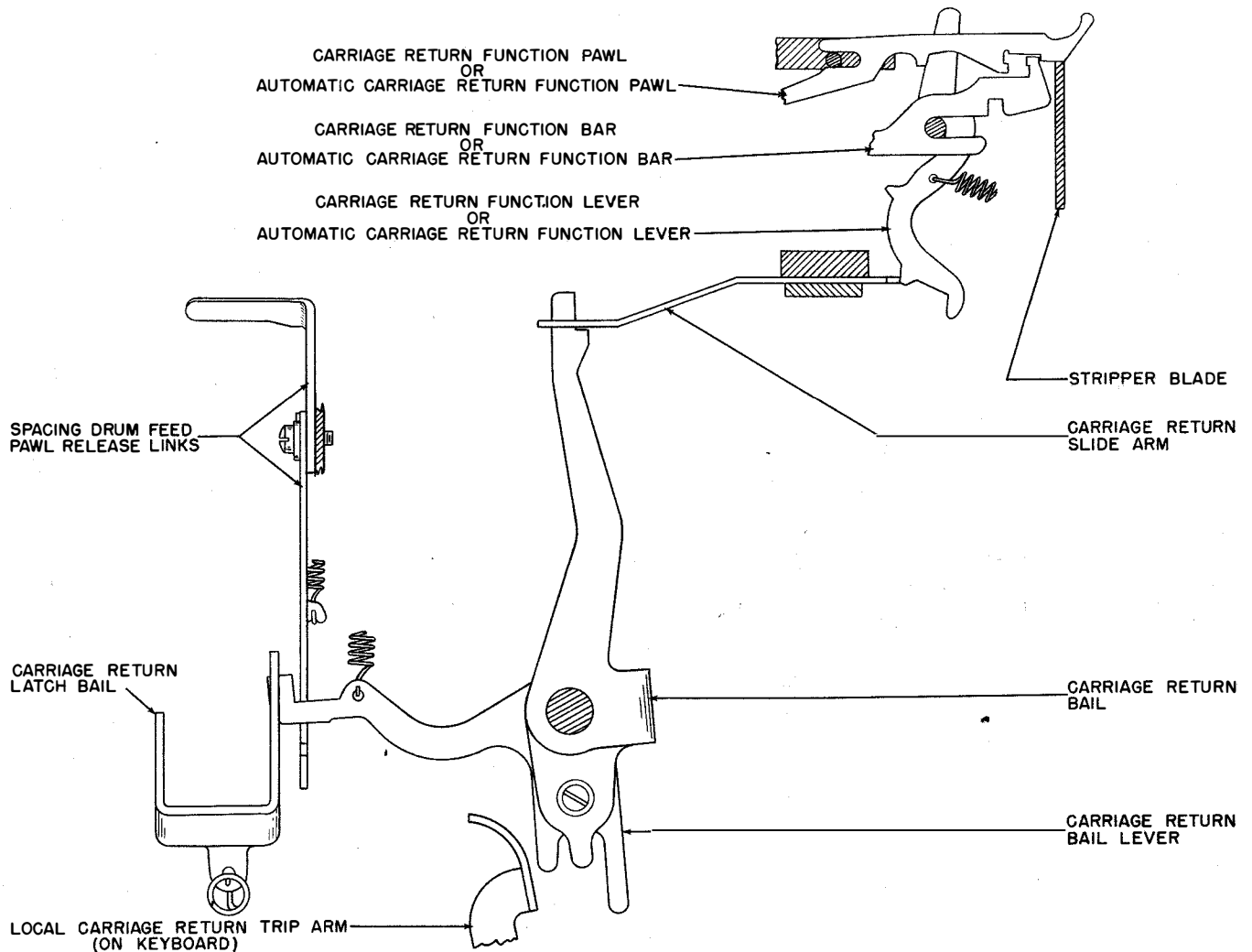


Figure 2-67. Carriage Return Function Mechanism

riage return bail lever reaches its lowest point, the carriage return latch bail locks it there. The disengagement of the spacing drum feed pawls from the spacing drum, permits the spring drum to return the printing and type box carriages toward the left side of the Automatic Typewriter. As the spacing drum nears the end of its counterclockwise rotation, a roller on its stop arm contacts the transfer slide which, in turn, drives the dashpot piston into the dashpot cylinder. The rate of deceleration provided by the cushioning effect of the trapped air is regulated by means of the dashpot vent screw and lock nut which determine the rate at which the air may escape. When the spacing drum reaches its extreme counterclockwise position, an extension on the stop arm trips the carriage return latch bail plate which is fastened to the carriage return latch bail. The latch bail disengages the carriage return bail lever and the feed pawls are again permitted to engage the spacing drum.

(b) Local (off line) operation of the carriage return mechanism may be obtained from the Keyboard. A keyboard mechanism described in paragraph 3.e. of this section, engages a projection on the carriage return bail lever, and causes the operations described in the preceding paragraph to take place.

(5) LINE FEED FUNCTION.

(a) The line feed function mechanism is located in the left end of the Automatic Typewriter. The reception of the line feed code causes the line feed function bar, pawl, and lever to operate (figure 2-69). The lower end of the line feed function lever engages the line feed slide arm and pushes it forward (to the left in the figure). The slide arm, in turn, moves the line feed clutch trip arm and trip lever about their pivot point until the trip lever releases the three-stop line feed clutch. The line feed gearing is such that each one-third revolution of the clutch will advance the platen by one

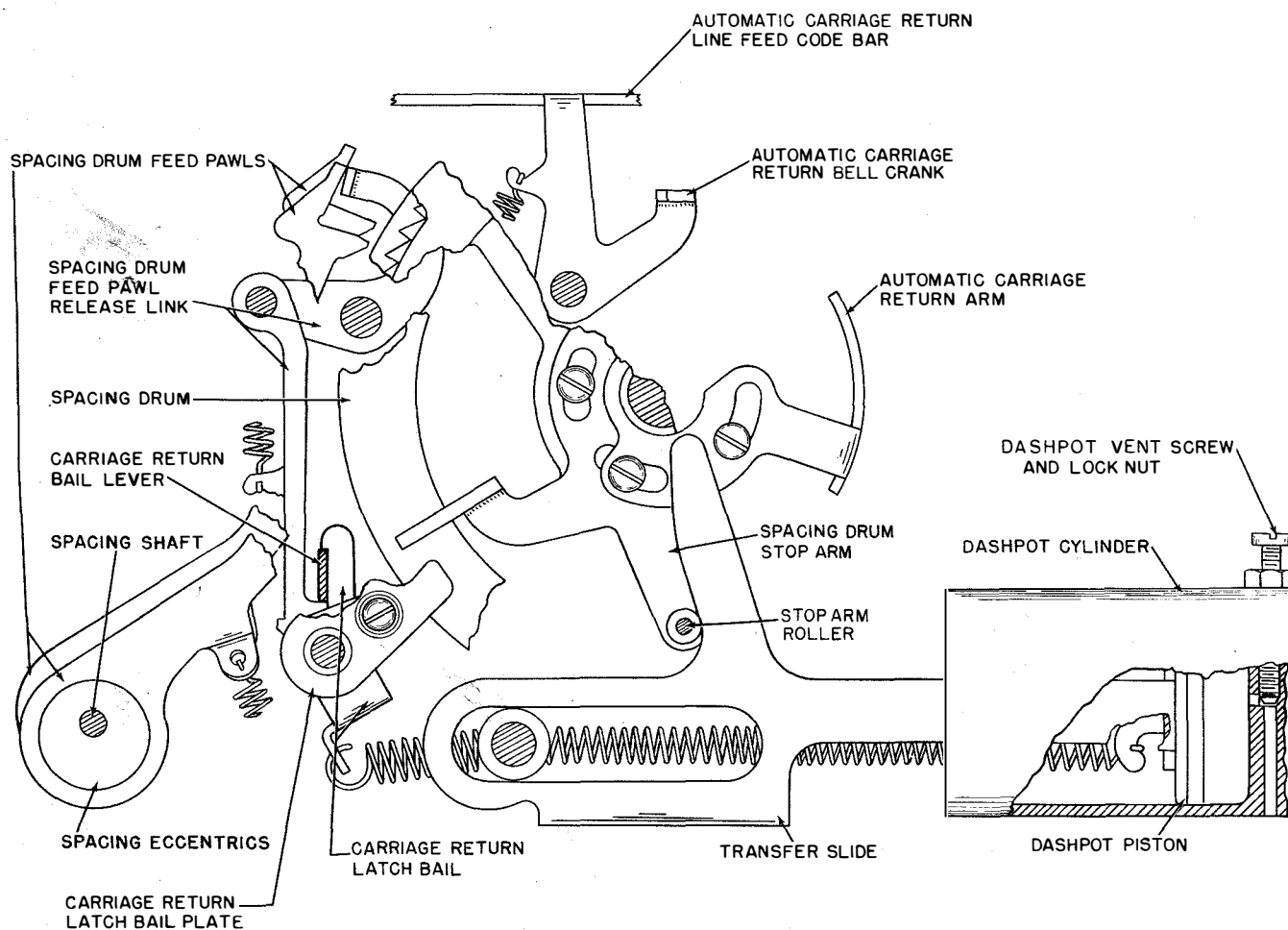


Figure 2-68. Carriage Return Mechanism

line. Therefore, the length of time that the line feed clutch trip lever is held away from the clutch will determine the number of line feeds that occur. The timing relationship between the stripper blade cycle and the main shaft rotation is such that the function pawl is not stripped from the function bar until after more than one-third of a revolution of the clutch has occurred. Thus, the line feed clutch trip lever will stop the clutch after two-thirds of a revolution, or double line feed has occurred. When single line feed is desired, it is necessary to strip the function pawl from the line feed function bar before the line feed clutch completes one-third of a revolution. This is accomplished by the use of an auxiliary line feed function pawl stripper which is driven by a stripper bail. The cam disk on the three-stop line feed clutch furnishes the motive force to operate the stripper bail once each one-third revolution of the line feed clutch. The stripper blade on which the slotted line feed function pawl stripper rides may be shifted toward the right or left by the camming action of the single or double line feed lever (figure 2-70). The upper end of the pivoted single or double line feed

lever protrudes from the upper left rear of the Automatic Typewriter where it rides in a two position detent bracket. When the lever is in position one (toward the front of the Automatic Typewriter), the stripper blade is positioned such that the two ears at the upper end of the line feed function pawl stripper are under the line feed and automatic line feed function pawls. When the lever is in position two (toward the rear of the Automatic Typewriter), the stripper blade is positioned such that the ears on the line feed function pawl stripper are between the function pawls. All other function pawls are stripped with the stripper blade in either position. When single line feed is being used, the line feed function lever is released too soon (by the line feed function pawl stripper) to prevent spacing. Therefore, an additional line feed function bar, pawl, and lever are installed in the extreme left end of the function box for the sole purpose of suppressing spacing on single line feed functions (figure 2-57). This mechanism, which always operates on the line feed function code, is released only by the stripper blade, and therefore holds the spacing suppression bail operated until the

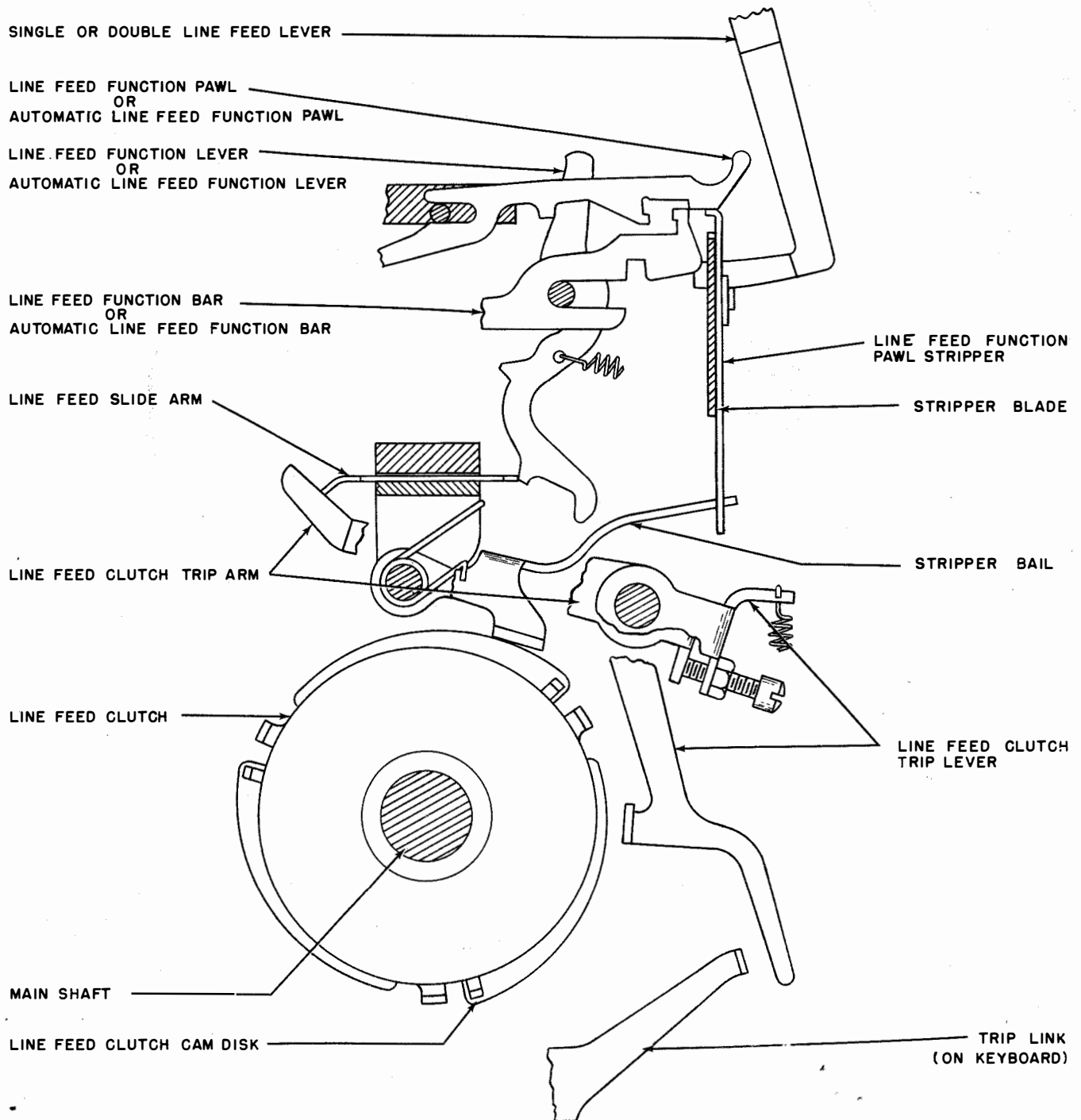


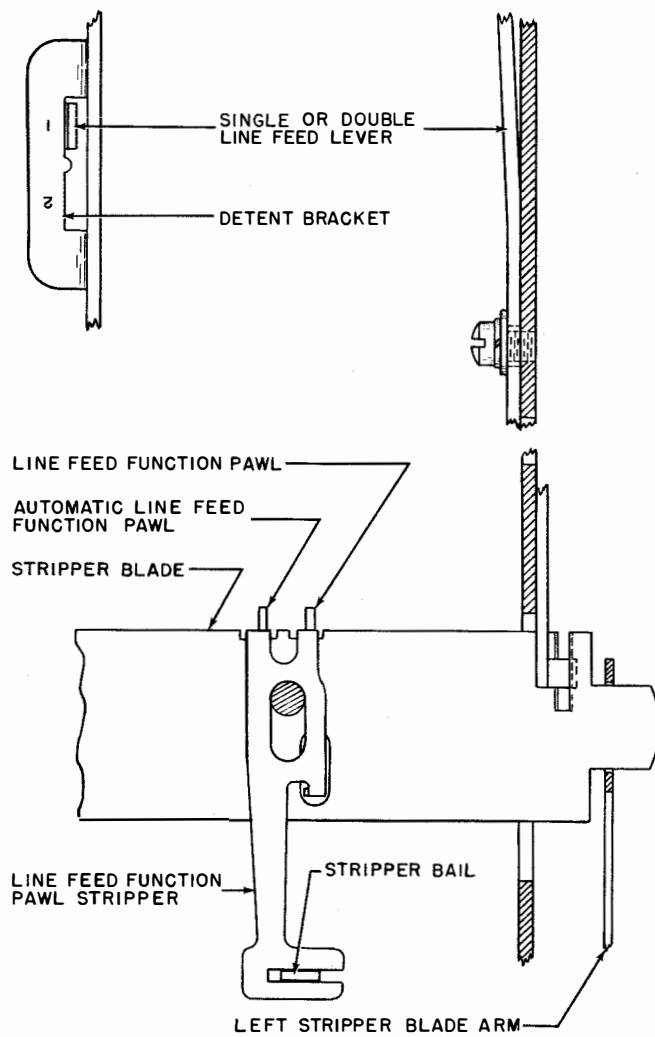
Figure 2-69. Line Feed Function and Clutch Trip Mechanism

spacing cycle is completed. After the line feed clutch is stopped by its trip lever, it is disengaged by its trip lever and latch lever in the same manner as the three-stop spacing clutch.

(b) Each one-third revolution of the line feed clutch causes its attached spur gear to rotate the line feed eccentric spur gear and its attached eccentrics one-half a revolution (figure 2-71). The eccentrics which are offset in opposite directions each carry a line feed

bar. These bars guided by the line feed bar bell crank alternately engage the line feed spur gear on the platen and advance the platen one line for each one-half turn of the eccentrics. A platen detent bail engages the line feed spur gear to retain the platen at each setting.

(c) When it is desired to manually position the platen, this may be accomplished by bearing down on and turning the platen handwheel. This causes the platen handwheel spur gear to engage the platen idler



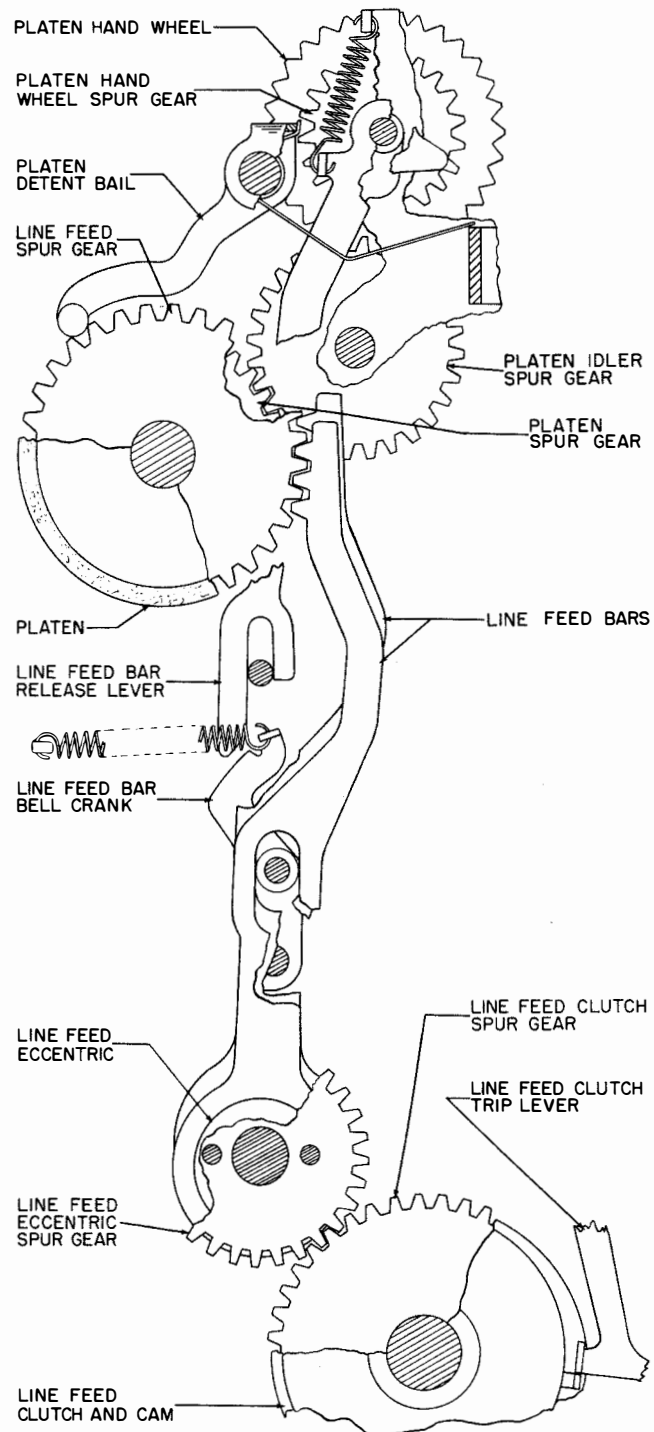
**Figure 2-70. Positioning Mechanism For Single or Double Line Feed**

spur gear which in turn is engaged with the platen spur gear on the platen shaft. At the same time the line feed bar release lever bears on the line feed bar bell crank and causes it to disengage the line feed bars from the line feed spur gear.

(d) Local (off line) operation of the line feed mechanism may be obtained from the Keyboard. A keyboard mechanism, described in paragraph 3.f. of this section, engages a projection on the line feed clutch trip lever and may hold the clutch engaged to provide continuous line feeding (figure 2-69).

**(6) AUTOMATIC CARRIAGE RETURN—LINE FEED FUNCTION.**

(a) If an operator fails to send the carriage return and line feed functions before the carriages are within one character of the right end of the line, the automatic carriage return arm on the spacing drum trips the automatic carriage return bell crank (figure



**Figure 2-71. Line Feed Mechanism**

2-68). As the bell crank turns clockwise, it shifts the automatic carriage return-line feed code bar to the right. Located adjacent to the carriage return and line feed function bars in the function box are automatic carriage return and line feed function bars (figure 2-57). These two function bars are identical and have only one code projection. This projection is located opposite the automatic carriage return-line feed code bar which



normally blocks the automatic carriage return and line feed function bars. When the code bar is shifted to the right these function bars and their associated function pawls and levers are operated. The automatic carriage return and line feed function levers operate respectively the carriage return slide arm and the line feed slide arm to cause the carriage return and line feed functions to simultaneously occur.

(7) SIGNAL BELL FUNCTION.

(a) For signaling purposes, a bell is located in the CY-870/UG and CY-871/UG cabinets. The circuit to the bell magnet E-756 is controlled by a set of normally open electrical contacts E-1301 and E-1302 mounted on the function box (figures 2-33 and 2-72). The signal bell function bar has six code lugs—five for the signal code and one for the letters-figures shift code bar (figure 2-57). In order to select the signal bell function, the letters-figures shift code bar must first be shifted to figures position. Then, each time the signal code for the letter S is received, the function lever will pulse the upper signal bell electrical contact once (figure 2-73). If the signal code for the letter S is received when the letters-figures shift code bar is in the letters position, the signal bell function bar will be blocked by the shift code bar.

(8) BLANK FUNCTION.

(a) Near the left end of the function box, are two identical function bars coded to operate when the signal code for blank function is received (figure 2-57). If, at any time, two consecutive blank signal codes are received, the mechanism operated by these two function bars will lock up the Keyboard. The single blank function lever has a projection which reaches over to engage the notch in the keyboard lock function bar and prevent the function bar from moving forward even though a blank signal code is received (figure 2-58). Therefore, the first blank signal code received will operate only the blank function bar. This function bar moves its function pawl which, in turn, operates the blank function lever and causes it to move out of engagement with the keyboard lock function bar and to be latched in place by the blank function lever latch (figure 2-74). If the next consecutive signal code is not a blank, the keyboard lock function bar will be blocked by the code bars, and the lower edge of the stripper blade will trip the blank function lever latch. The latch will release the blank function lever and permit it to re-engage the keyboard lock function bar and reset the mechanism. If, however, the next consecutive signal code is a blank, the keyboard lock function bar will move forward before the stripper blade can trip the blank function lever latch and release the blank function lever. The keyboard lock function bar operates its function pawl which in turn operates the keyboard lock function lever

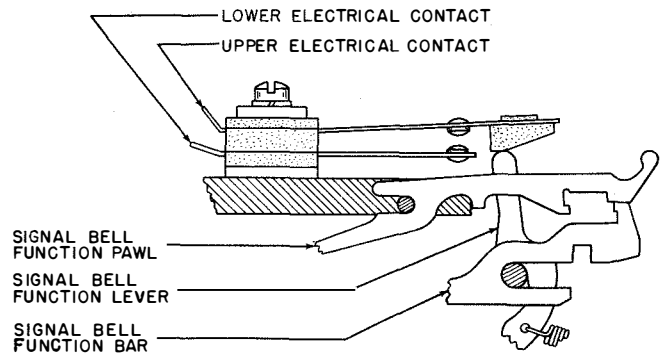


Figure 2-72. Signal Bell Contact Mechanism, Unselected

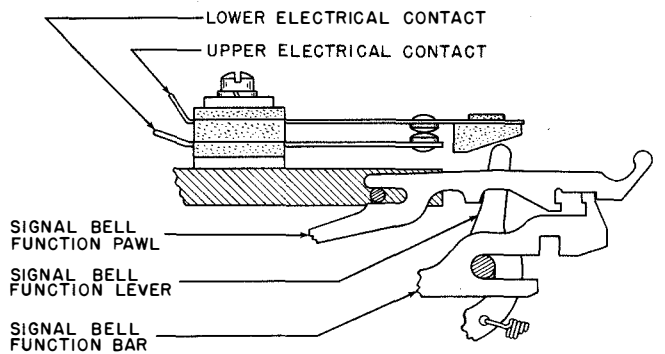


Figure 2-73. Signal Bell Contact Mechanism, Selected

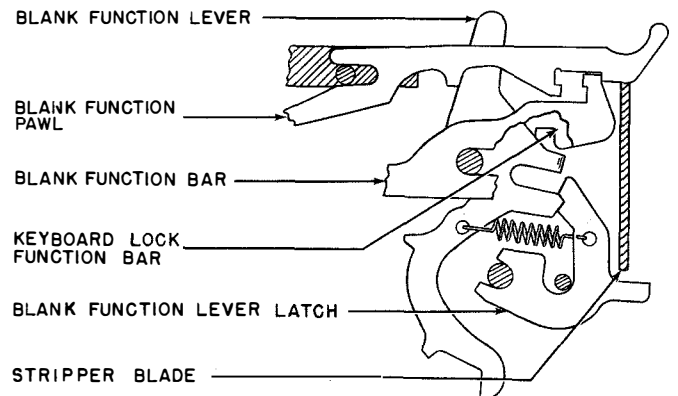


Figure 2-74. Keyboard Lock Priming Mechanism

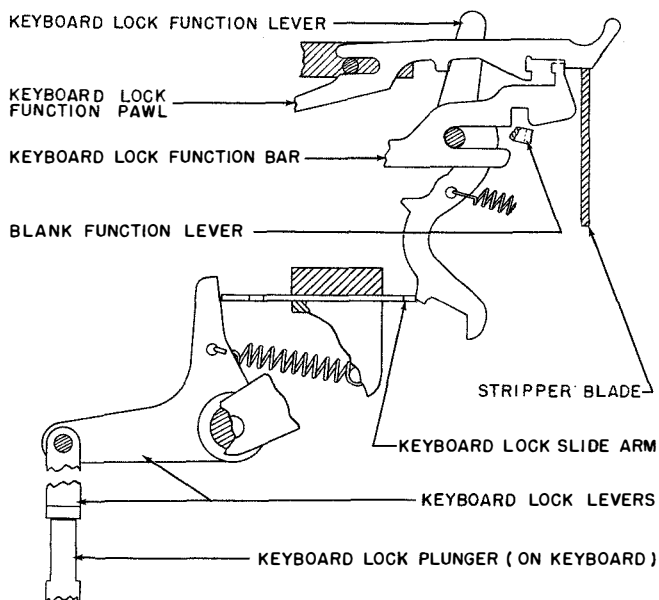


Figure 2-75. Keyboard Lock Mechanism

(figure 2-75). The keyboard lock function lever moves the keyboard lock slide arm forward (toward the left in the figure). This, in turn, actuates the keyboard lock levers and causes them to push downward on a plunger (which projects upward from the Keyboard) and lock the Keyboard. The operation of the keyboard lock mechanism in the Keyboard is described in paragraph 3.i. of this section.

5. MOTORS.

a. AC MOTOR (SYNCHRONOUS) PD-17/U. (See figures 1-9 and 2-76.)—The synchronous motor is for use with single phase; 115 volt (plus or minus 10 per cent) alternating current, at a frequency of 60 cycles per second (plus or minus 0.5 cycle). It is a 1/20 horsepower, 3600 rpm, two pole, wound stator, ball bearing motor, with a squirrel cage type rotor. The stator has two windings, a main operating winding, and a starting winding. The starting winding is in series with a 43 to 48 mf electrolytic capacitor, and with a centrifugally operated switch. The switch S-502 is located in the moulded bakelite housing at one end of the motor, and the operating mechanism S-503 is mounted in an anodized aluminum housing on an extension of the motor shaft. The switch is closed when the motor is stopped, and remains closed from the time the motor is started until the rotor reaches a speed of approximately 2700 rpm. At that speed, the centrifugal force developed is sufficient to overcome the tension of the springs in the switch operating mechanism, so that the mechanism releases the switch and allows it to open. The opening of the switch disconnects the auxiliary winding, and series

capacitor C-501 from the line, and the rotor E-501 continues to accelerate until it reaches synchronous speed (3600 rpm). The motor is wired such that the rotor rotates counterclockwise when viewed from the switch end. In order to prevent overheating and possible damage to the motor if it is stalled, a thermal cutout switch S-501 with a manual reset button is mounted in the bakelite housing at one end of the motor. This switch is wired in series with both the main and auxiliary motor windings, and if a current greater than 11 amperes is drawn by the motor the switch will open the circuit. There are two fans located within the motor housing, one at each end of the rotor. These draw cooling air in through the slots in the end bells, and exhaust it through the slots in the motor housing. The end bells have rubber vibration mounts by means of which the motor sets in the ends of its mounting bracket. The rubber mounts are held in the bracket by means of mounting straps. The motor shaft has a tapped hole for use in fastening the intermediate shaft driving helical gear. All end play is taken up by means of a conical shaped spring which bears against the outer race of one of the ball bearings. The motor mounting bracket is fastened to the Keyboard by means of two nut plates and six screws and lock washers.

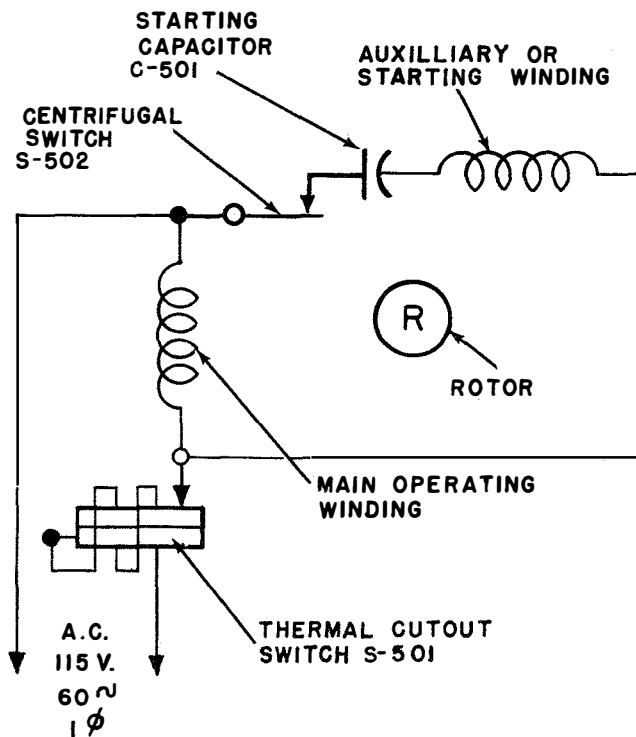


Figure 2-76. AC Motor (Synchronous) PD-17/U, Schematic Wiring Diagram

b. AC MOTOR (SYNCHRONOUS) PD-17A/U. (See figure 2-76A.)—The synchronous motor is for use with single phase, 115 volt (plus or minus 10 per cent) alternating current, at a frequency of 60 cycles per second (plus or minus 0.5 cycle). It is a  $\frac{1}{20}$  horsepower, 3600 rpm, two pole, wound stator, ball bearing motor, with a squirrel cage type rotor. The stator has two windings, a main operating winding, and an auxiliary winding. The auxiliary winding is in series with a 43 mf a.c. electrolytic capacitor C-501, and with a current operated motor starting relay K-501. The initial starting current causes the relay to pull up and its contacts close the auxiliary winding circuit. As the rotor gains speed, the current flowing through the motor (and also the relay coil), decreases. When a predetermined current value is reached the relay armature is released, the relay contacts are opened, and the auxiliary winding circuit is disconnected from the line. The rotor E-501 continues to accelerate until it reaches synchronous speed (3600 rpm). The motor is wired in such a manner that the rotor rotates counterclockwise when viewed from the fan end. The starting relay and capacitor together with a thermal cutout switch S-501 are mounted in a compartment on the underside of the motor. The thermal cutout switch is in series with both the main and auxiliary motor windings, and if excessive current is drawn by the motor, (due, for example, to a blocked rotor), the switch will open the circuit. This is to prevent overheating and possible damage to the motor if it is stalled. The switch may be manually reset if tripped,

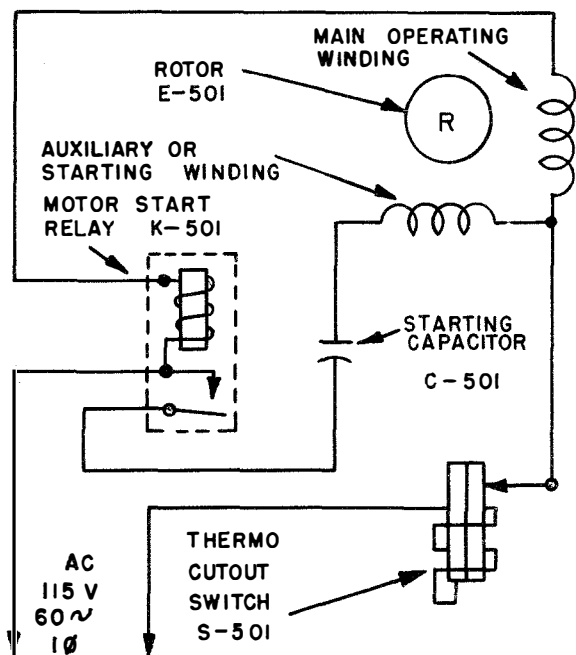


Figure 2-76A. AC Motor (Synchronous) PD-17A/U,  
Schematic Wiring Diagram

by depressing its red button which projects upward through the motor mounting plate. There are two fans located within the motor housing, one at each end of the rotor. These draw cooling air in through the slots in the end bells and exhaust it through the slots in the motor housing. The end bells have rubber vibration mounts by means of which the motor sets in the ends of its mounting bracket. The rubber mounts are held in the bracket by means of mounting straps. The motor shaft has a tapped hole for use in fastening the intermediate shaft driving helical gear. All end play is taken up by means of a conical shaped spring which bears against the outer race of one of the ball bearings. The motor mounting bracket is fastened to the Keyboard by means of four screws and lockwashers.

c. AC MOTOR (GOVERNED) PD-18/U. (See figure 2-77.)—The series governed motor is for use with single phase, 115 volt (plus or minus 10 per cent) alternating current, at a frequency of 50 to 60 cycles per second. It is a  $\frac{1}{20}$  horsepower, 3600 rpm ball bearing motor which depends on an electro-mechanical governor for its speed regulation. The armature E-609, with a 48 segment commutator is wired in series with the two field windings, and the governor contacts E-606 and E-617. A 250 ohm, 40 watt resistor R-601 and a 0.5 mf capacitor C-602, are connected in parallel with the governor contacts. When the contacts are closed the resistor is shorted out. When the contacts are open the resistor is in series with the motor, to limit its operating current, and thus reduce its speed. The capacitor serves as a spark suppressor for the governor contacts. The combination fan and governor is mounted on one end of the motor shaft. The fan draws cooling air through the motor housing, and also serves as a mounting plate for the governor slip rings and for the governor contact mechanism (mounted on opposite sides of the fan). Connections to the two slip rings, which are wired to the governor contacts, are made by means of two brushes E-601 and E602, mounted on the ends of the motor housing. Normally the governor contact spring holds the governor contact E-606 against the contact screw E-617 (figure 2-78). When the motor shaft exceeds a predetermined speed, the centrifugal force developed on the governor contact overcomes briefly the pull of the governor spring, and the governor contact leaves the contact screw until the motor slows down. The tension on the contact spring may be adjusted to maintain the motor speed at 3600 rpm. In order to make this adjustment, means are provided to compare the motor speed with a standard. An aluminum cover fits against the side of the fan and encloses the governor contact mechanism. The outside of the cover is finished in white, with four black stripes equally spaced about its periphery. This serves as a target which should appear to stand almost

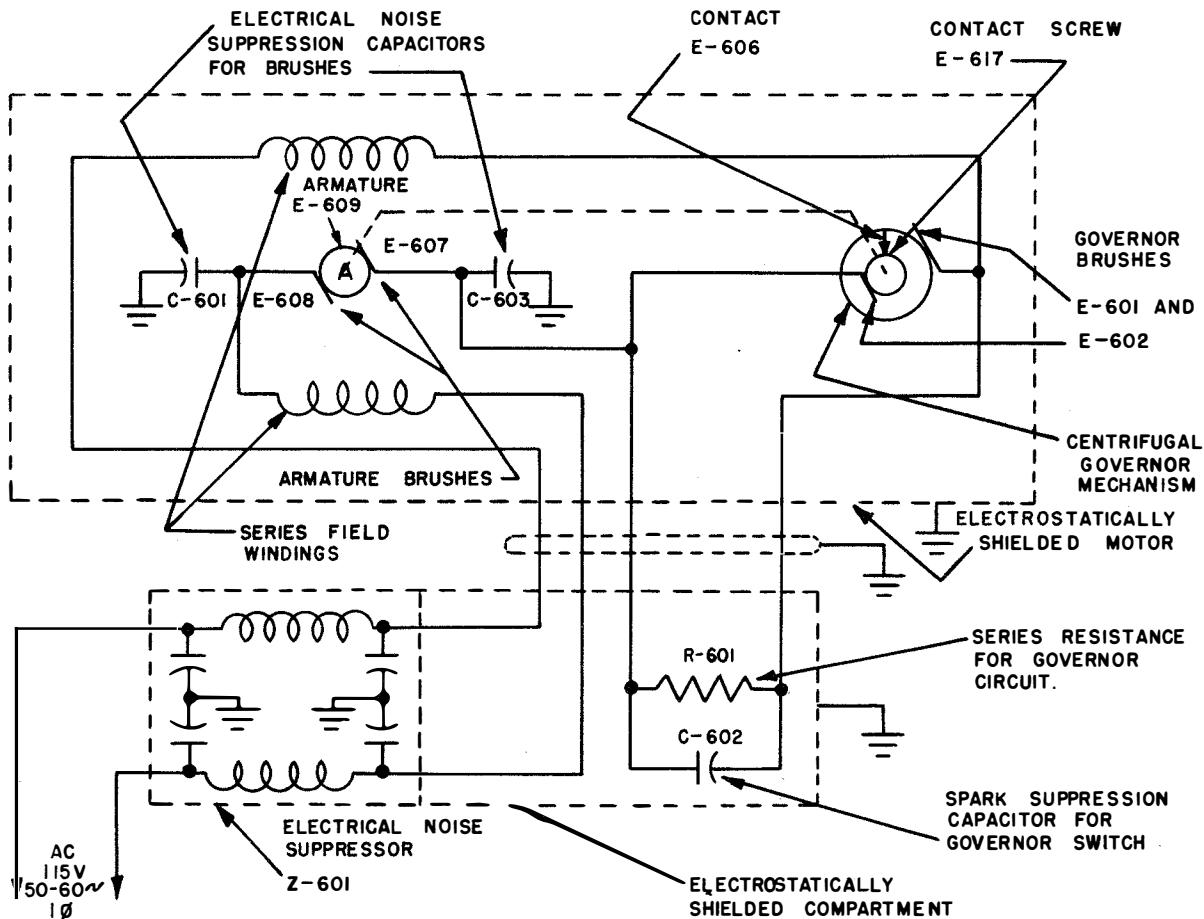


Figure 2-77. AC Motor (Governed) PD-18/U, Schematic Wiring Diagram

still at 3600 rpm, when viewed through the moving shutter of a 120 vibrations per second tuning fork. The two motor brushes E-607 and E-608 are protected by 800 mmf capacitors C-601 and C-603 which are connected between the brushes and the grounded frame of the motor. These tend to by-pass any electrical noise created by the brushes as they make and break contact with the various segments of the armature commutator. The motor is wired in such a manner that the armature rotates counterclockwise when viewed from the governor end. The method of mounting the series motor is similar to the method of mounting the synchronous motor. The housing provided on the underside of the mounting bracket contains both the 250 ohm resistor and 0.5 mf capacitor in the governor circuit as well as a power leads electrical noise suppressor. The purpose of the electrical noise suppressor in the motor power input circuit is to prevent any radio interference which may be generated by the motor from being radiated by the motor power leads. To prevent this disturbance from being radiated directly from any of the motor components or wiring, the entire AC Motor PD-18/U is enclosed by grounded metal housings with screened openings. The screening is to permit the circulation of cooling air through the motor and across the governor resistor and also to permit the target to

be viewed when checking motor speed. A threaded plug which is provided in the governor shield housing may be removed to permit the insertion of a screwdriver when necessary to adjust the motor speed. Access to the compartment on the underside of the motor may be gained by removing a screw and lockwasher and sliding the bottom cover plate aside.

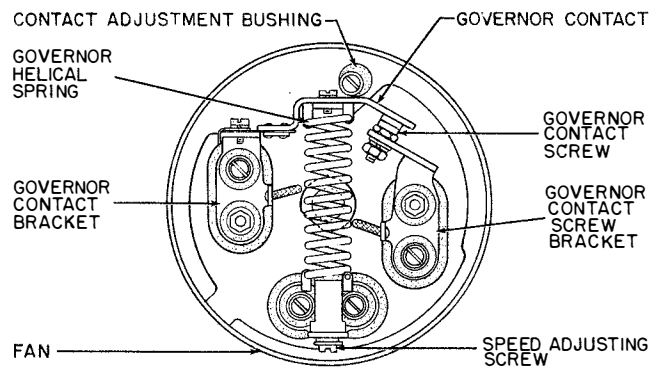


Figure 2-78. Governor For AC Motor PD-18/U

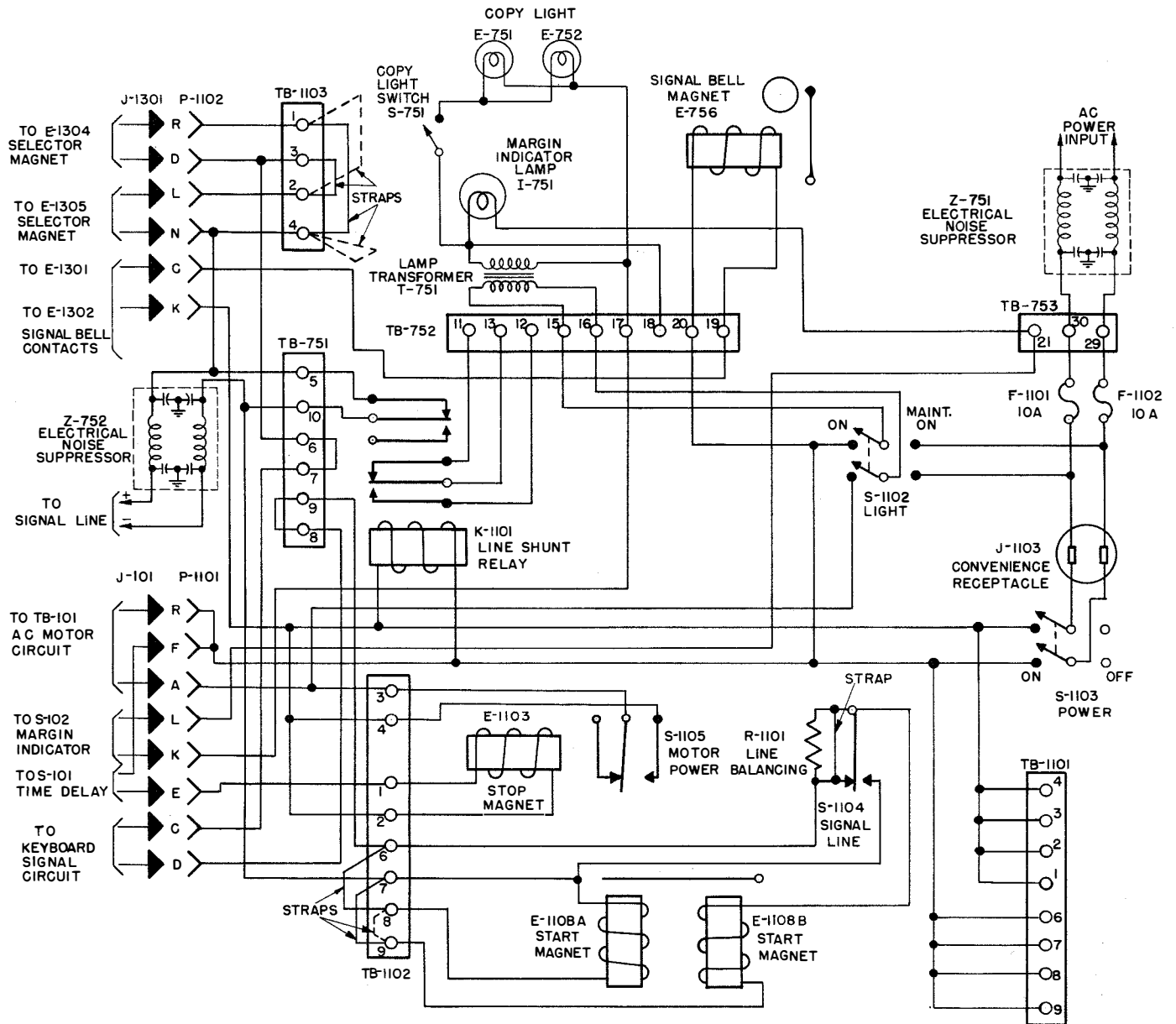


Figure 2-79. Power Distribution Panel SB-154/UG and Cabinets CY-870/UG and CY-871/UG, Schematic Wiring Diagram



**6. POWER DISTRIBUTION PANEL SB-154/UG.**

(See figures 1-12, 1-13 and 2-79.)

a. The Power Distribution Panel is located behind the Keyboard inside the CY-870/UG or CY-871/UG Cabinet, and is held in place by two studs. The main power switch, located in the lower front corner of the right end of the panel chassis, is engaged by the fork on the power switch extension shaft. This shaft extends through the front of the Cabinet below the Keyboard and is equipped with a knob so that the Teletypewriter may be turned on or off from outside its Cabinet. Four legs on the chassis project upward from the corners, for use when the Power Distribution Panel is turned upside down for servicing. The complete Power Distribution Panel is composed of the basic panel plus an electrical motor control accessory.

b. BASIC PANEL.—The basic part of the Power Distribution Panel consists of a chassis upon which is mounted all of the cabling which interconnects the Keyboard and the Automatic Typer, together with the necessary plug connectors, fuses, switches, terminal blocks, convenience receptacle, and line shunt relay. The cable assemblies which go to the Keyboard and the Automatic Typer pass through holes in the two top mounting plates which are located at the left and right ends respectively of the chassis. The cable which enters the left side of the chassis connects with the line terminal board TB-751 in the Cabinet. The cable which enters the right side of the chassis connects with the cabinet terminal board TB-752 and with the power input terminal board TB-753 which is also in the Cabinet. The signal bell magnet E-756 is located on the underside of the Cabinet and connects to the cabinet terminal board TB-752. The copy light lamps E-751 and E-752 with their switch S-751, and the margin indicator lamp I-751 (controlled by switch S-102 in the Keyboard), are located in the cabinet dome, and connect with the secondary of transformer T-751 which also is mounted in the cabinet dome. The primary of T-751 connects to the cabinet terminal board TB-752. The electrical noise suppressor Z-751 is located in the Cabinet under the Keyboard, and is in series with the a-c power input which is brought to the power input terminal board TB-753 and thence into the Power Distribution Panel. Upon entering the chassis, the power input is fused by two 10 ampere fuses F-1101 and F-1102 before it reaches the convenience receptacle J-1103, the power switch S-1103, and the three position light switch S-1102. In the center or OFF position of S-1102 which connects with the primary of T-751 at TB-752, the lamp transformer is completely disconnected from any power circuit. With S-1103 OFF, the copy

light may be turned ON by throwing S-1102 to the MAINT ON position, and S-751 in the Cabinet to the ON position. When S-1103 is ON, the power input is applied to the power terminal board TB-1101 and to the magnet coil of the signal line shunt relay K-1101. In the de-energized position of K-1101, its contacts shunt the signal line at TB-751 in the Cabinet. When K-1101 is energized by operation of S-1103, the contacts open to remove the shunt. In the left or ON position of S-1102, power for T-751 in the Cabinet is taken from TB-1101 and is controlled by the motor switch S-1105 in the electrical motor control mechanism. See paragraph 6.c. of this section. The circuit from the margin indicator switch S-102 in the Keyboard connects with the margin indicator lamp circuit in the Cabinet at TB-752 and TB-753. The circuit from the motor stop switch S-101 in the Keyboard picks up power at TB-1101, and connects with the stop magnet E-1103 in the electrical motor control mechanism. The circuit from the signal bell electrical contacts E-1301 and E-1302 in the Automatic Typer picks up power at TB-1101 and connects with the wires from the signal bell magnet E-756 at TB-752 in the Cabinet. The AC Motor circuit from the Keyboard picks up power at TB-1101, and connects with S-1105 in the electrical motor control mechanism. The electrical noise suppressor Z-752 is located in the Cabinet under the Keyboard and is in series with the signal line which is brought to the signal line terminal board TB-751 in the Cabinet. The signal line circuits from both the Keyboard and the Automatic Typer connect with TB-751, where they may be arranged for either single loop or double loop operation. In addition, wires from the selector magnets E-1304 and E-1305 in the Automatic Typer connect with terminal board TB-1103 in the Power Distribution Panel. Two strap wires on TB-1103 which connect E-1304 and E-1305 "in parallel" for 0.060 ampere signal line current operation may be rearranged (dashed lines in figure 2-79) to connect E-1304 and E-1305 "in series" for 0.020 ampere operation.

c. ELECTRICAL MOTOR CONTROL.—The electrical motor control mechanism is mounted in the center of the Power Distribution Panel. All connections to this mechanism are made through its terminal board TB-1102. The purpose of the mechanism is to start the AC Motor when the signal line current is interrupted, and to stop the AC Motor if the signal line circuit remains unbroken for a specified period of time. In the equipment as furnished, the start magnets E-1108A and E-1108B in the electrical motor control mechanism are wired in parallel for 0.060 ampere signal line current operation. For 0.020 ampere signal line current operation, the strap wires on TB-1102 may be rearranged (dashed lines in figure 2-79) to connect E-1108A and E-1108B in series. Also, the strap across the line bal-

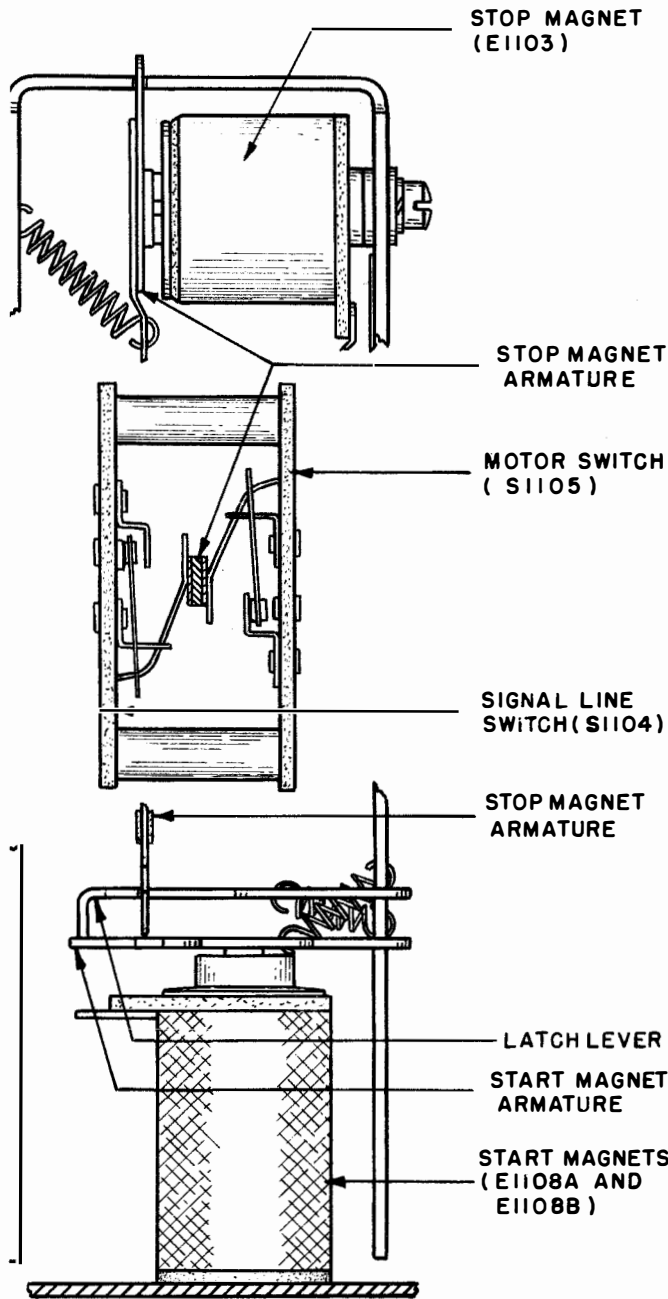


Figure 2-80. Electrical Motor Control Mechanism, Stop Position

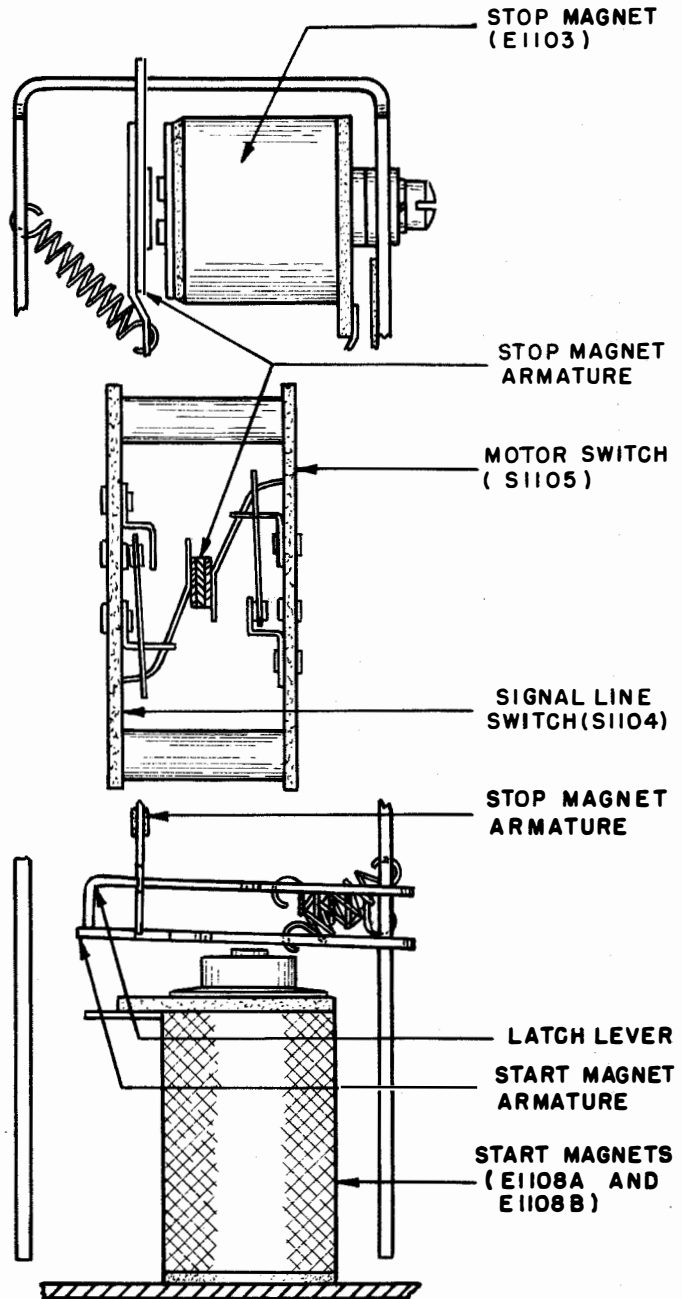


Figure 2-81. Electrical Motor Control Mechanism, Open Line Position

ancing resistor R-1101 for 0.060 ampere operation must be removed for 0.020 ampere operation. The resistor R-1101 is switched into the line circuit by S-1104 when the start magnet coils are switched out, in order to compensate for the loss of their resistance and to minimize unbalance in the line circuit. The manner in which the electrical motor control mechanism operates is as follows:

(1) STOP POSITION. (See figure 2-80.)—In this position, the AC Motor is shut down, and the steady signal line current keeps the start magnets E-1108A and E-1108B, energized. The start magnet armature has been pulled downward and the stop magnet armature has been pulled toward the right in which position it is being held by the latch lever. The motor switch S-1105, operated by the stop magnet armature is open,



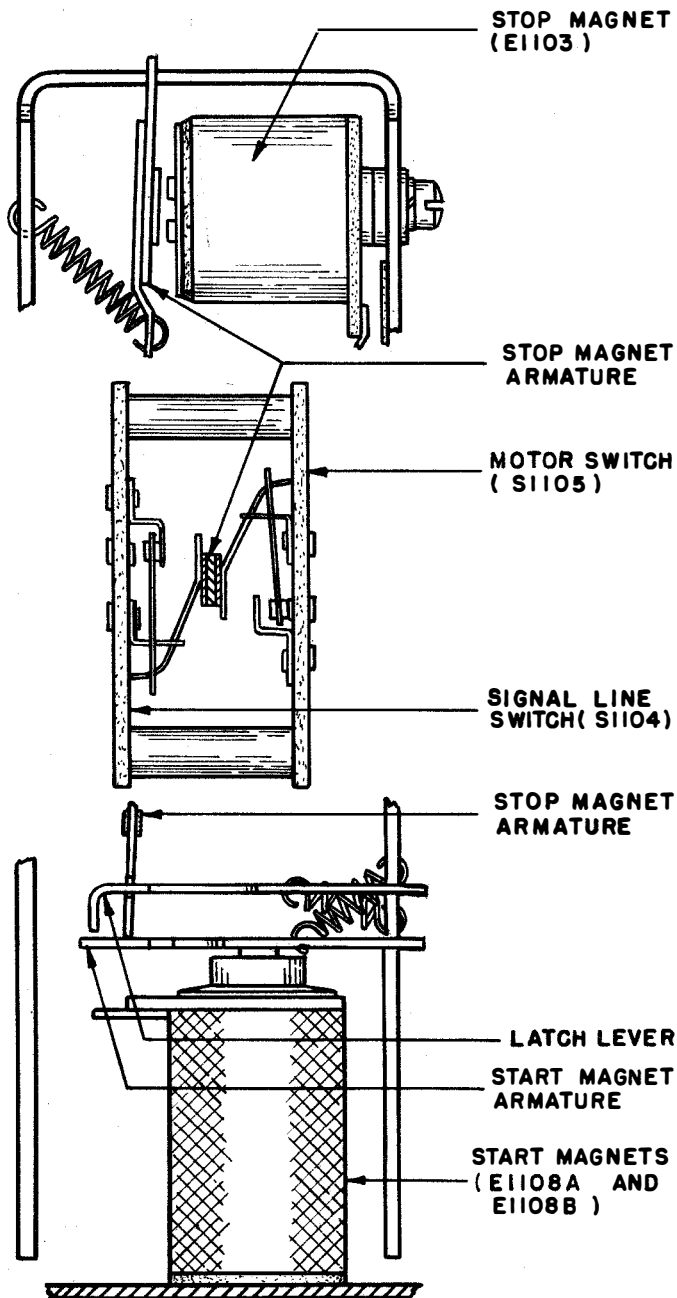


Figure 2-82. Electrical Motor Control Mechanism, Start Position

and the signal line switch S-1104 also operated by the stop magnet armature is completing the start magnet circuit.

(2) OPEN LINE POSITION. (See figure 2-81.)—In this position, the signal line has just been opened, the start magnet E-1108A and E-1108B have been de-energized, and the start magnet armature has been released. As the start magnet armature moved upward, it carried the latch lever with it. The latch lever released the stop magnet armature which started to swing to the left. However, the stop magnet armature immediately struck the start magnet armature and became blocked. The slight movement of the stop magnet armature was not sufficient to change the positions of the switches S-1104 and S-1105.

(3) START POSITION. (See figure 2-82.)—In this position, the signal line has just been closed, and the start magnets E-1108A and E-1108B have been energized to pull the start magnet armature downward and release the stop magnet armature. The stop magnet armature has swung to the left and operated switches S-1104 and S-1105. When S-1104 operated, it removed the start magnets E-1108A and E-1108B from the signal line circuit so that their armature would not vibrate with the line signals. When S-1105 operated, it completed the circuit to the AC Motor, and to the copy light.

(4) STOP POSITION. (See figure 2-80.)—In order for the electrical motor control mechanism to return to this position and stop the AC Motor, the motor stop switch S-101 in the Keyboard must be pulsed by the time delay mechanism as shown in paragraph 3.l. of this section. This pulse energizes the stop magnet briefly and causes the stop magnet armature to swing to the right and again operate switches S-1104 and S-1105. As S-1104 operates, it places the start magnet coils back in the signal line circuit where they become energized and pull the start magnet armature downward. This allows the latch lever to engage the stop magnet armature and hold it in the stop position. As S-1105 operates, it opens the circuit to the AC Motor and to the copy light.

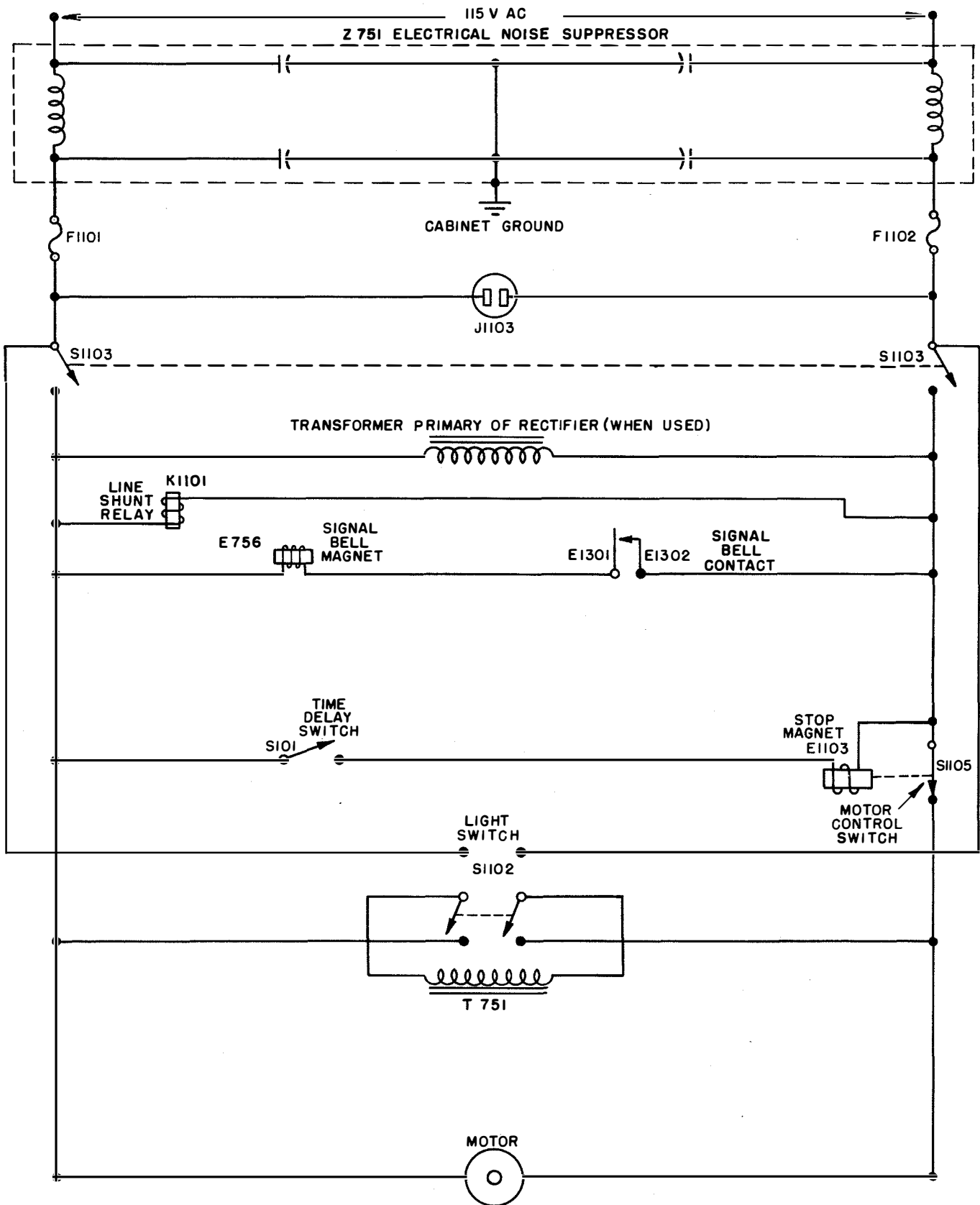


Figure 3-1. Primary Power Distribution Diagram

## SECTION 3 INSTALLATION

### 1. GENERAL.

The Teletypewriters TT-47/UG and TT-48/UG are packed complete in one wooden box. Teletypewriters TT-69/UG and TT-70/UG are similarly packed. Each set has eight packages enclosed by the outer wooden box. These eight packages contain one each of the following items: Automatic Typer, Keyboard, Power Distribution Panel, AC Motor, console-type or shelf-type Cabinet, spare parts, and instruction books.

### 2. UNPACKING THE EQUIPMENT.

- a. Cut the steel strapping along the top edges of the box.
- b. Pry the lid off the box and tear the waterproof barrier.
- c. Remove the eight cartons from the box.
- d. Open each carton and remove the contents.

### 3. INSTALLING THE CABINETS.

a. Four tapped bushings are provided in the feet of the Cabinet to secure the shelf model. In selecting the bolts to be used, make certain to choose a length that will not extend through the top of the bushing. Thread size and necessary dimensions are shown in figure 3-5.

#### Note

The signal line and power cables must be installed before securing the shelf-type Cabinet.

b. Four shock mounts are provided to secure the console-type Cabinet. Hardware for securing the shock mounts to the floor is not furnished with the equipment. Assembly of shock mounts to Cabinet and necessary dimensions are shown in figure 3-5. The shock mounts are packed in a carton which is taped to the rail inside the Cabinet and stamped 151593.

### 4. POWER AND LINE CONNECTIONS.

(See figures 1-11 and 1-12.)

#### a. CABINETS TT-47/UG AND TT-48/UG.

(1) Remove the panel that extends across the front of the lower section by removing its four mounting screws. Remove the insulator covers from the three terminal boards located in the upper rear portion of the Cabinet. Insert an a-c power cable through the large opening in the left rear corner of the lower shelf

and up through the right BX connector in the center of the upper shelf. Connect the leads to the electrical noise suppressor as shown in figure 3-2. (For any specific installation refer to the applicable installation drawing.)

(2) Insert the signal line cable through the same opening in the lower shelf but through the left BX connector in the center of the upper shelf. If single loop operation is used (keyboard and automatic typer in series), connect the positive (+) lead to the upper terminal and the negative (-) lead to the lower terminal of the electrical noise suppressor as shown in figure 3-2. If double loop operation is used (keyboard and automatic typer separated) connect the SEND line as described above. Insert the RECEIVE line through the large opening in the left rear corner of the lower shelf and up through the 7/8-inch hole in the upper shelf. Remove the white wire from the upper half of terminal 5 on TB-751 and connect it to terminal 7. Remove the black wire from terminal 10 and connect it to terminal 8. Connect the positive (+) lead of the RECEIVE line to terminal 5 and the negative (-) lead to terminal 10 of TB-751 as shown in figure 3-3.

(3) To relieve tension on the terminal connections, clamp the cables in place by means of the BX connectors. If additional thickness is required, friction tape may be wound around the cables at the clamping point.

(4) Replace the panel across the front of the lower section.

b. CABINETS TT-69/UG AND TT-70/UG.—Insert the power and signal line cables into the right and left BX connectors respectively. The connections are the same as described in paragraphs 4.a.(1) and 4.a.(2).

c. When installing any of the above sets, a ground wire should be brought in and connected to the Cabinet ground screw located just above terminal board TB-753 as shown in figure 3-3. The ground wire should also be connected to the signal line electrical noise suppressor ground terminal as shown in figure 3-2.

#### CAUTION

A good ground is important for satisfactory operation of the equipment.

### 5. ASSEMBLY OF EQUIPMENT.

a. POWER DISTRIBUTION PANEL SB-154/UG.

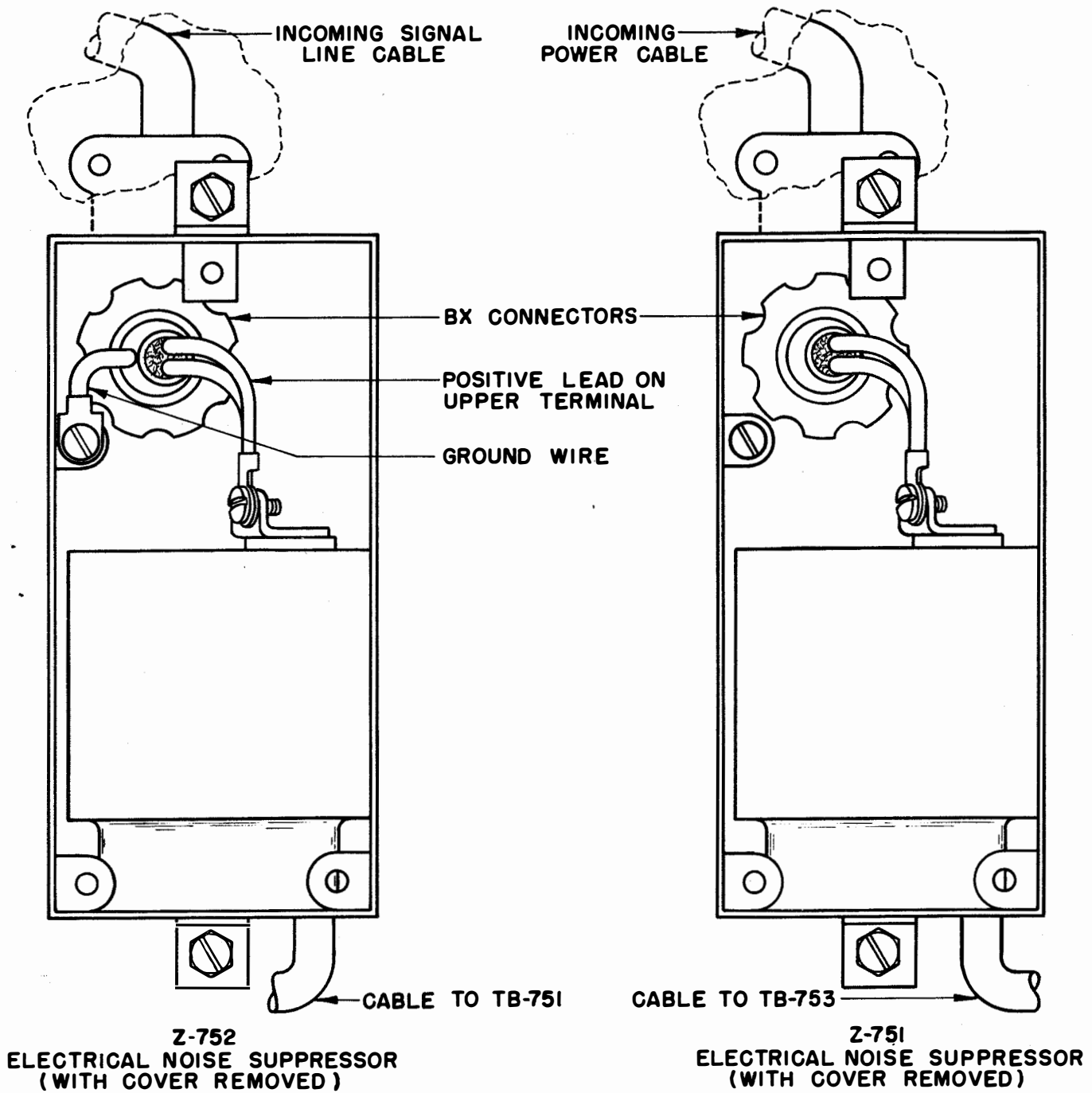


Figure 3-2. Power and Signal Line Connections

(1) With the dome raised, place the Power Distribution Panel in the rear of the Cabinet with the legs extending upward and name plate and serial number plate facing the front of the Cabinet. Secure the Panel to the shelf by means of the two studs furnished in the muslin bag tied to the Panel. Drop the studs through the holes located at each end of the Panel and screw them into the nuts welded to the underside of the shelf.

(2) If single loop operation is used, connect the leads of the cables from the Power Distribution Panel to terminal boards TB-751, TB-752 and TB-753 as shown in the applicable portion of figure 3-3. If double loop operation is used, make connections to terminal boards TB-752 and TB-753 the same as for single loop operation. Make connections to terminal board TB-751 in accordance with the DOUBLE LOOP OPERATION diagram of figure 3-3.

CHANGE 1

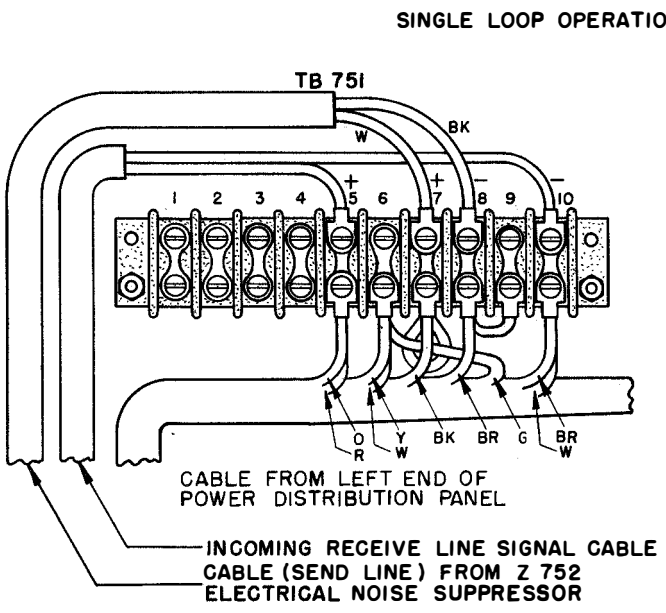
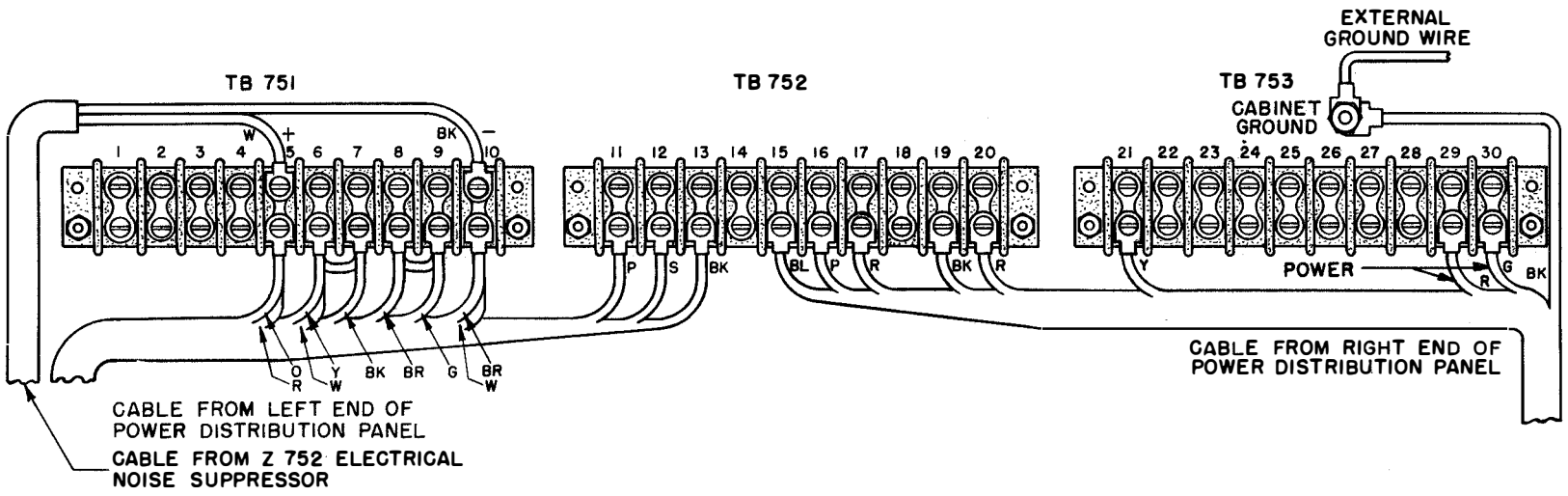


Figure 3-3. Power Distribution Panel Connections

**Note**

Make certain that the black strap is removed from terminal 6 and taped or connected to terminal 7.

(3) The unit is wired for 0.060 ampere operation at the factory. If 0.020 ampere operation is desired, change wiring as shown in NOTE 7 on wiring diagram (figure 7-137).

(4) Remove the rear cross bar of the cradle assembly by removing its two mounting screws, lock washers, and flat washers.

(5) Untie the power switch extension shaft from the cradle assembly. Remove the knob from the shaft by loosening the two set screws. Insert the shaft, from inside of Cabinet, through the hole located at the right end of the front panel. Push the shaft through far enough to allow the rear end of the shaft to enter the locating hole in the Power Distribution Panel, and at the same time place the slotted extension of the shaft over the toggle switch which is mounted on the right side of the Power Distribution Panel. Replace the knob on the end of the shaft which protrudes through the Cabinet, and keep the narrow portion of the knob to the right. Tighten the set screws. Hook one end of the spring (furnished) around the switch extension shaft and hook the other end into the hole in the right arm of the cradle assembly.

**b. AC MOTORS PD-17/U AND PD-18/U.**

(1) Remove the motor gear and intermediate driven gear from the small cardboard box stamped 151060, 151075, or 151100. Remove the screw and lock washer in the left end of the motor shaft. Place the motor gear on the motor shaft with the geared end toward the Motor. Secure the gear with the screw and lock washer just removed. Remove the two screws and lock washers from the hub on the right end of the intermediate gear shaft. Mount the intermediate driven gear on the shaft with the flat side of the gear to the right. Secure the gear with the two screws and lock washers just removed.

(2) Remove the four 1/4-32 hex head screws from the muslin bag tied to the Motor. Place the Motor in position on the Keyboard and secure it with the four screws and lock washers just removed. Before tightening the mounting screws make certain that the motor gear and intermediate driven gear are properly meshed.

(3) Remove the insulator cover from terminal board TB-101 just to the left of the Motor. Connect the motor leads to terminals 1 and 2 of this terminal board. When installing a governed motor, connect the ground shield to the screw located in the base directly beneath the motor gear. Replace the insulator cover with the No. 1 stamping toward the rear.

**c. AUTOMATIC TYPER MX-1115/UG.** (See figure 7-21.)

(1) Remove the four 1/4-32 hex head screws, with captive lock washers, from the Keyboard. Place the Automatic Typer on the Keyboard. Make certain that the front feet on the Typer are placed over the locating studs provided on the Keyboard. Rotate the Motor by hand to insure proper meshing of the gears. Secure the Automatic Typer with the four screws just removed.

(2) **INITIAL ADJUSTMENTS.**—The following six adjustments, shown in section 7, should be made before placing the unit in the Cabinet.

(a) Typer and Signal Generator Gearing (figure 7-22).

(b) Keyboard and Motor Gearing (figure 7-23).

(c) Local Line Feed Function Arm (figure 7-24).

(d) Local Carriage Return Function Arm (figure 7-25).

(e) Lock Function Arm (figure 7-26).

(f) Time Delay Mechanism (figure 7-27).

**d. KEYBOARD MX-1114/UG.**

(1) Remove the cross bar from the front of the Cabinet by loosening the two knurled thumb screws that secure it.

(2) Remove the two studs from the rear cross bar previously removed from the cradle assembly. With the centerline of the tapped holes to the rear of the centerline of the elongated holes in the rear cross bar, secure the Keyboard, with Motor and Typer, to the rear cross bar by means of the two studs just removed.

(3) Remove the two studs from the front cross bar hinge. Place the Keyboard on the cradle assembly in the Cabinet. Loosen the two front cross bar mounting screws and position the bar in its elongated mounting holes so that the holes in the Keyboard and the tapped holes in the hinge are in alignment. Secure the Keyboard to the front cross bar hinge by means of the two studs just removed.

(4) Replace the front cabinet cross bar, stamped "CAUTION: REMOVE BEFORE TILTING UNIT", in its mounting slots with the wider side of the bar downward. Be careful not to jam the bar against the keyboard contact box. Tighten the two knurled thumb screws.

(5) To seal the rubber sealing plate around the Keyboard against the Cabinet, push the Keyboard toward the rear of the Cabinet as far as possible. Hold it in this position and tighten the two front cross bar mounting screws.

(6) Secure the rear cross bar to the cradle assembly by means of the two screws, lock washers, and flat washer previously removed.

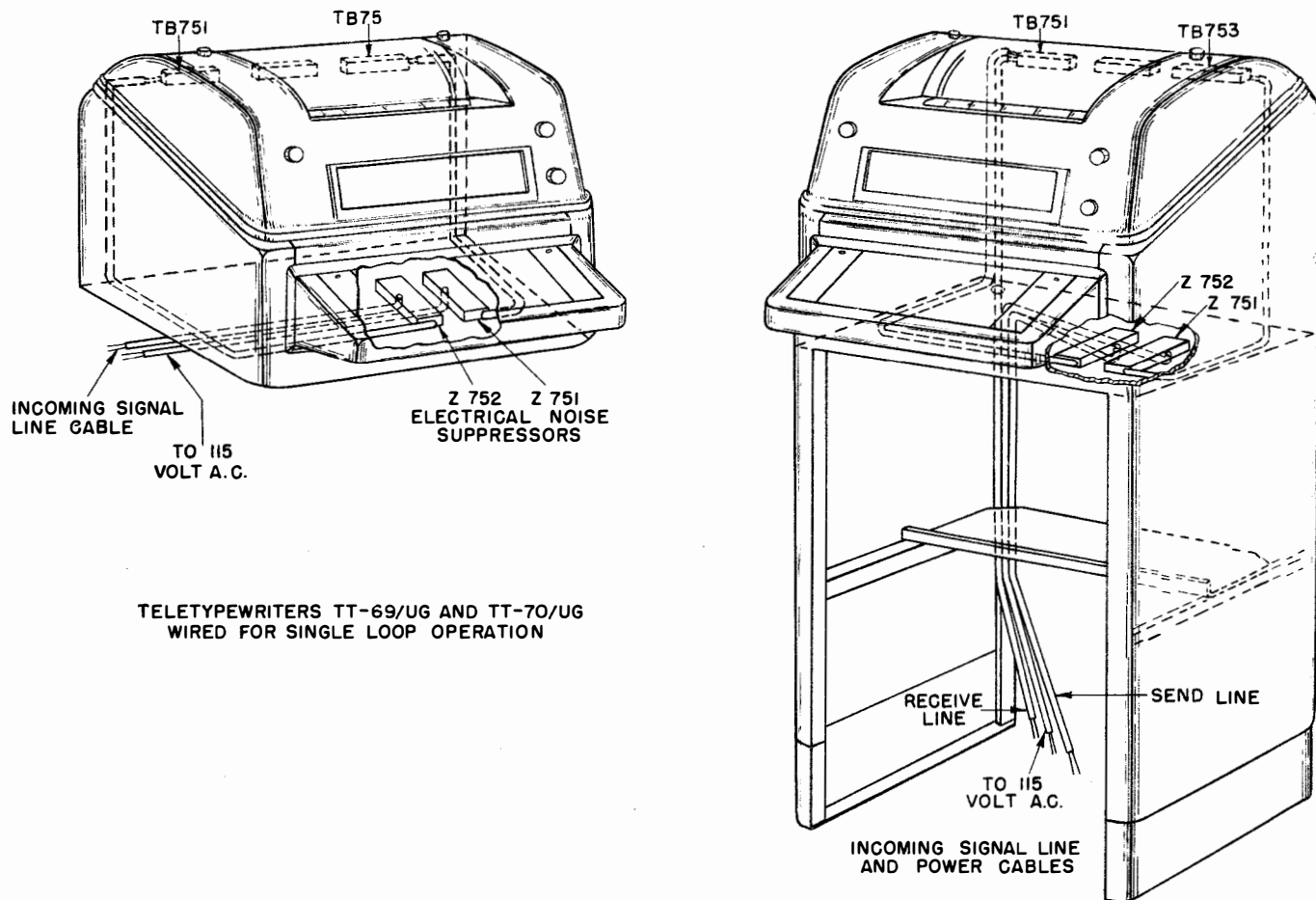


Figure 3-4. System Pictorial Diagram

(7) Loosen the screws which secure the clamping brackets on the receptacles located at the left rear corner of the Keyboard and the right side of the Automatic Typer.

(8) Insert the plug on the cable from the right end of the Power Distribution Panel into the receptacle on the right side of the Automatic Typer.

(9) Insert the plug on the cable from the left end of the Power Distribution Panel into the receptacle on the left rear corner of the Keyboard.

(10) Place the clamping brackets over the plugs and tighten their screws.

**6. MECHANICAL CHECKING OF EQUIPMENT.**

a. A visual check of all fuses, plugs, screw terminal

connections, and lamps for loosening or breakage should be made before putting the equipment into operation.

b. Make certain that the power knob is downward in its OFF position before closing the main power line to the equipment.

c. The light switch (ON, OFF, MAINT ON) should be in the ON position.

d. The copy light switch should be in the ON position.

e. Refer to section 4, paragraph 5, for instructions on installing paper and ribbon.

**7. OPERATING TESTS.**

a. Type several lines of a test sentence such as "The

quick brown fox . . . etc." and check for accuracy.

b. The local line feed key (LOC LF) when depressed, shall cause paper to feed out of the machine at approximately three times the speed obtained when the line feed key is repeatedly operated.

c. The lock key, (KBD LOCK) when depressed, shall prevent operation of any other key except the local line feed, keyboard unlock, break, and local carriage return keys. It shall remain depressed until released by the keyboard unlock key.

d. The unlock key, (KBD UNLK) when depressed, shall unlock the keyboard. The BREAK key, when depressed, shall hold the transmitting line open. If the duration of the open-line interval is greater than two character cycles the keyboard lock shall be caused to operate.

e. The repeat key (REPT), when depressed together with any other key except the local keys, shall cause repeat transmissions of the signal.

f. The local carriage return key, when depressed, shall cause the carriage to be returned.

g. The bell shall ring clearly on single or repeated operations of the BELL key.

b. Determine that operation of the FIGS key conditions the machine for the typing of upper case characters and that operation of the LTRS key conditions it for the typing of lower case characters.

i. Determine that operation of the SPACE BAR conditions the machine for the typing of lower case characters where this feature is desirable. If not desirable, disable by adjusting the function pawl disabling screw section 7, figure 7-83.

j. Determine that the Motor shuts off after an idle period of from one-half to two minutes where this feature is desirable, and restarts when the break key is depressed or when the selector starts to receive signals. If this feature is not desirable, disable the delay mechanism on the Keyboard as indicated in section 7, figure 7-28.

k. If irregularities in operation are observed, notify authorized maintenance personnel.

#### 8. MARGIN INDICATING LAMP.

The margin indicating lamp should illuminate between the 66th and 68th space from the beginning of a line. Adjust if necessary by positioning the margin indicator cam disk on the spring drum with its three screws loosened (figures 2-29 and 2-44).

#### 9. FINAL CHECKS.

The equipment has been thoroughly tested and adjusted at the factory and should not require further adjusting. However it is recommended that the setting of the range scale and the motor speed (governed type) be checked. Refer to section 4, paragraph 8 for the procedure to be followed in checking the motor speed and to section 4, paragraph 9 for the procedure in checking the orientation range.

#### Note

Under certain conditions, filter Z-101 may contribute to signal distortion in the signal line circuit. At the time of installation, the signals should be checked for excessive distortion. When present, it should be compensated for in order to retain the desired quality of the signals. This may be accomplished by the addition of wave shaping elements in the signal line circuit.



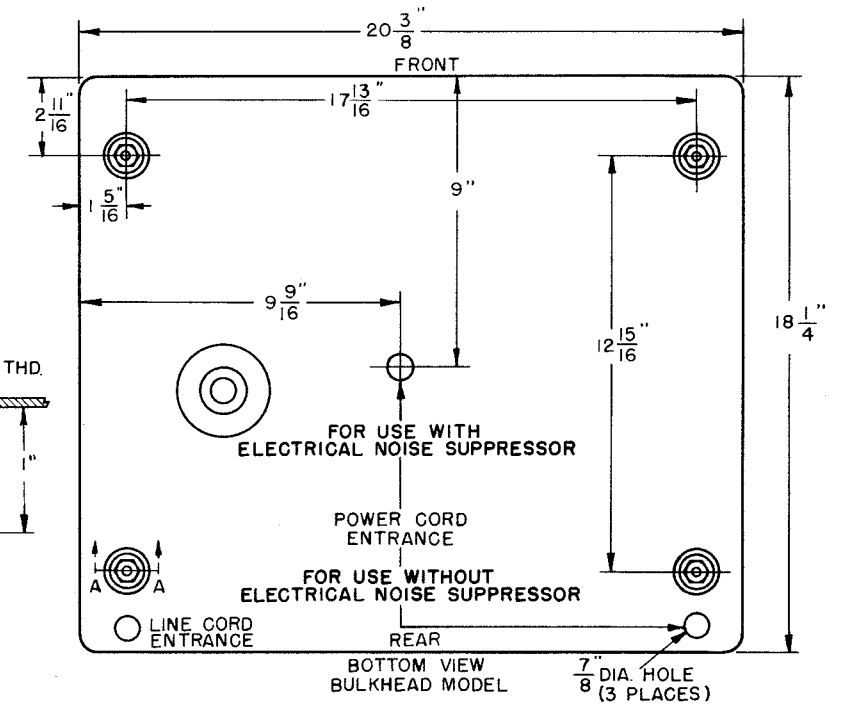
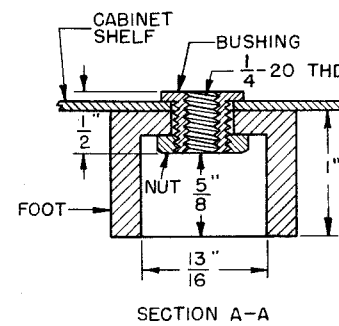
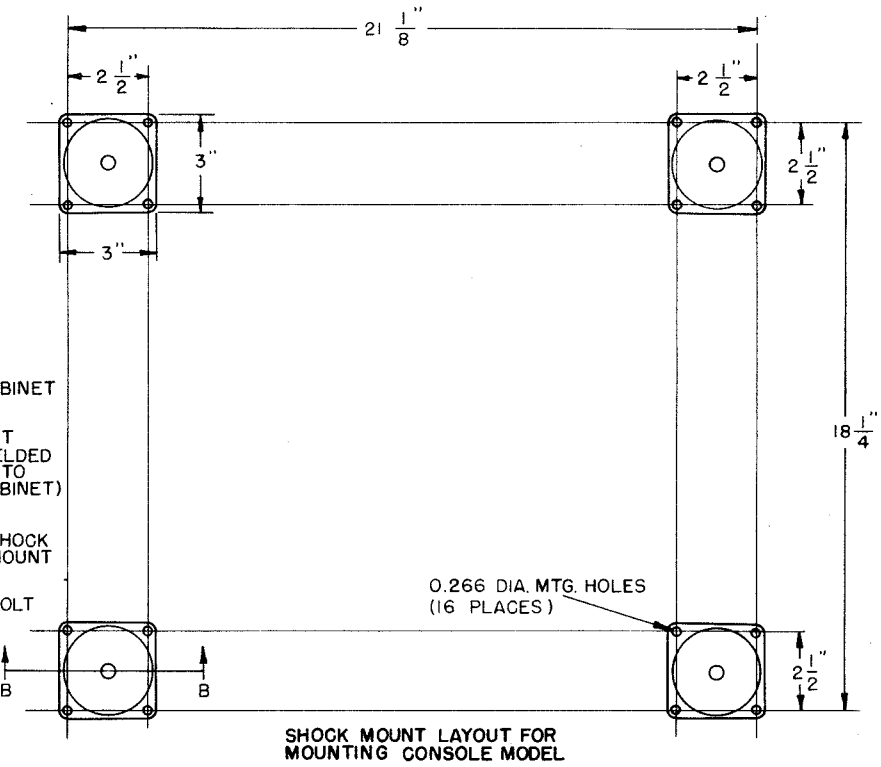
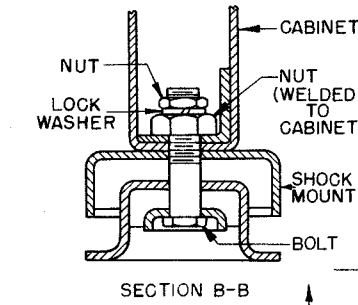
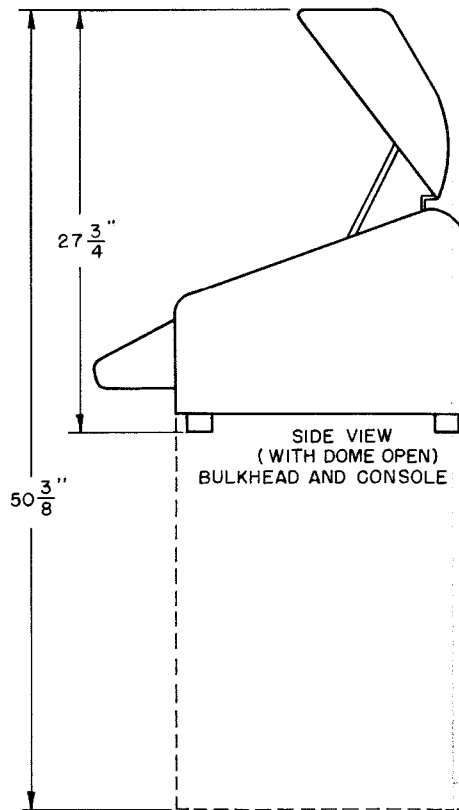
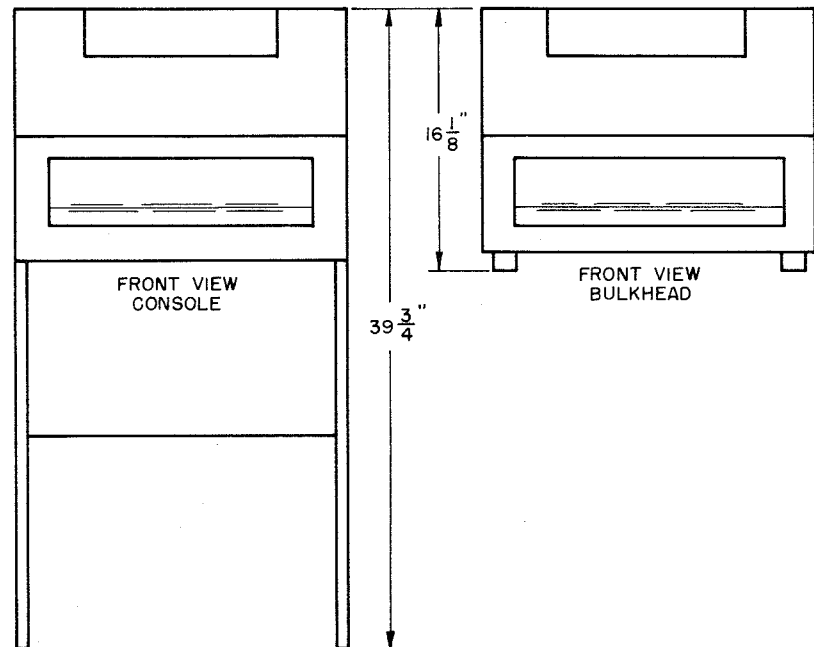
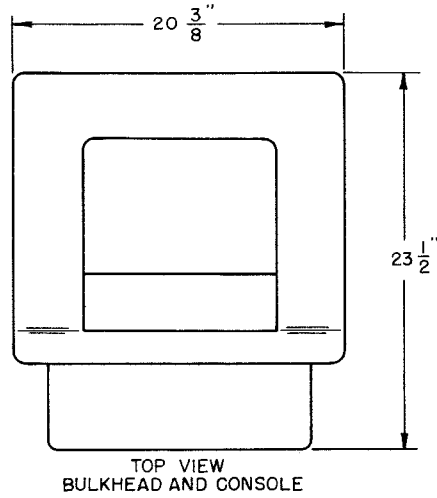


Figure 3-5. Outline and Mounting Dimensions

## SECTION 4 OPERATION

### 1. INTRODUCTION.

Teletypewriters TT-47/UG, TT-48/UG, TT-69/UG, or TT-70/UG provide means for exchanging typewritten page messages between two or more distant points which are similarly equipped and connected by a telegraph channel. The Keyboard of the Teletypewriter is essentially similar to the keyboard of a conventional typewriter. However, the following differences should be noted: The Keyboard of the Teletypewriter has only three rows of conventional keys. The platen is held stationary while the type box carriage, and printing carriage, advance from left to right during the typing process. Nontyping functions such as the return of the carriages for starting a new line, the shifting operations, and line feeding are performed automatically by signals that originate either at a distant station or at the local Keyboard. The Teletypewriter is arranged for operation on five-unit start-stop permutation code and prints the alphabet in capitals only. It is designed to operate at speeds of 368, 460, or 600 operations per minute (opm). Conversion from one speed to another necessitates a change in the driving gears. The Keyboard must be operated with a uniform rhythm in order to prevent omission errors in the copy

due to speed in excess of that for which the machine is adjusted. The action performed by the function keys (figure 4-1) is detailed in the following paragraphs.

### 2. ON-LINE FUNCTIONS.

*a.* SPACE BAR.—This bar, located at the front of the Keyboard is used to send spaces (as between words).

*b.* CAR. RET.—The carriage return key returns both the type box carriage and the printing carriage toward the left to start a new line of typing.

*c.* LINE FEED.—This key, when depressed, feeds the paper upward one or two spaces dependent upon the positioning of a single-double line feed lever located on the Automatic Typewriter (figure 4-2).

*d.* FIGS.—The figures key is used to condition the machine for the printing of figures, punctuation marks, or other upper-case symbols.

*e.* LTRS.—The letters key is used to condition the machine for printing of letters characters.

*f.* BELL.—Operation of this key (which is upper-case action of the S key) subsequent to pressing the FIGS key, will cause a signal bell to ring locally and at the distant stations.

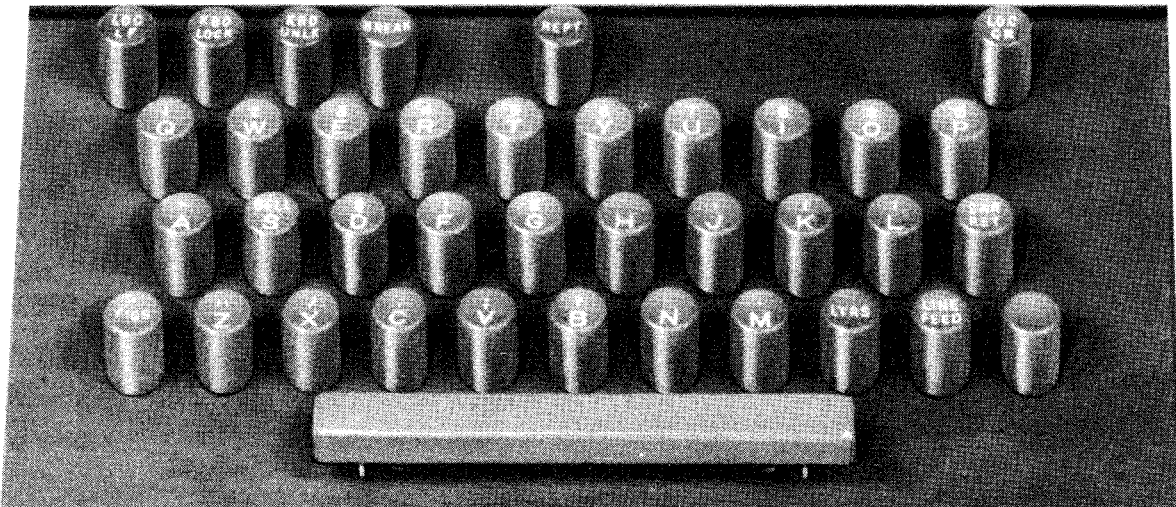


Figure 4-1. Keyboard Keys

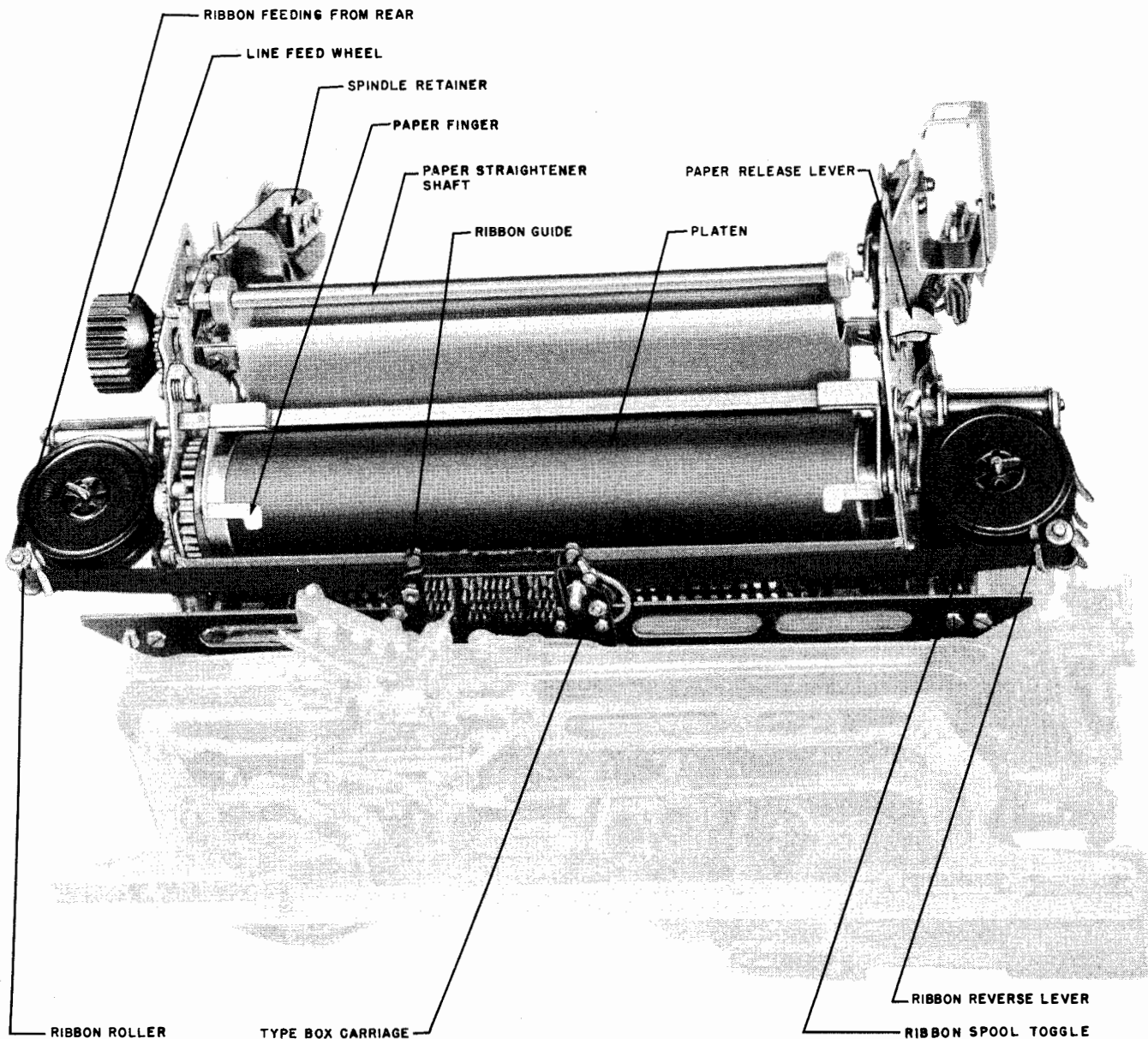


Figure 4-2. Automatic Typewriter MX-1115/UG, Top View

g. **BLANK.**—Pressing this key twice, (effective either upper or lower case) will lock all Keyboards on the circuit and render them inoperative by setting up the **RECEIVE** condition. Restoration to the **SEND** condition is accomplished, under individual circumstances, through the operation of a **KEYBOARD UNLOCK (KBD UNLK)** key by the operator who desires to send from his Keyboard.

b. **BREAK.**—This key is used to interrupt transmission from a distant station or to lock all Keyboards prior to initiating transmission.

i. **REPEAT (REPT).**—This key is used in conjunction with other keys or the space bar to accomplish repeat transmission while two keys are held depressed.

**CAUTION**

The left and right margins of Teletypewriters are adjusted as directed in Section 7. The operator is not authorized to make these adjustments.

**3. OFF-LINE FUNCTIONS.**

When it is desirable to apply certain functions to the local equipment only, the operator may utilize special keys, which are identified as follows:

a. **LOCAL LINE FEED (LOC LF).**—This key is used to feed the paper upward on the local machine only.

b. **LOCAL CARRIAGE RETURN (LOC CR).**—This

key is used to return the carriages to the beginning of the line on the local machine only.

*c.* **KEYBOARD LOCK (KBD LOCK).**—Operation of this key conditions local equipment for receiving only by locking the Keyboard.

*d.* **KEYBOARD UNLOCK (KBD UNLK).**—This key is used to condition the local Keyboard prior to starting transmission.

#### 4. CHARACTERS PER LINE.

*a.* The marginal signal light located to the right of the copyholder illuminates six characters before the end of the line. Care should be exercised not to overtype the last character. In case overtyping should occur, the Automatic Typer is arranged to carriage return and line feed automatically when it reaches an adjustable setting somewhere between the 66th and 73rd character.

*b.* The margin light illuminates on the 66th printed character (spaces included) for lines of 72 character length (standard communications practice).

#### 5. PAPER AND RIBBON.

(See figures 4-2, 4-4 and 4-5.)

*a.* To replenish the supply of paper, open the dome of the Cabinet, move the paper release lever (figure 4-2) on the Automatic Typer toward the rear, slide one of the spindle retainers toward the rear and remove the paper spindle. Insert the spindle in a fresh roll of paper and remount it so that the paper unwinds from underneath. Feed the paper over the paper straightener shaft and fold the end of the paper backward to square it off. With the paper release lever toward the rear, start the paper feeding around the platen and then restore the release lever to its forward position. Depress the platen handwheel and continue to feed the paper upward. Do not disturb the ribbon. Make certain that the paper passes under the paper fingers which may be raised temporarily to facilitate the operation. It may be necessary to operate the release lever momentarily when finally straightening the paper.

*b.* To replace the ribbon, open the glass door in the dome, raise the ribbon spool toggles (figure 4-2) to the vertical position and remove both spools. Engage the hook that is on the end of the new ribbon in the hub of the empty spool. Wind a few turns of the ribbon onto the empty spool to make sure that the reversing eyelet has been wound upon the spool. Place the spools on the ribbon spool shafts in such a manner that the ribbon feeds from the rear of each spool without twisting. Turn each spool shaft slightly until the driving pins on the spool shafts engage the holes in the spools. Thread the ribbon forward around both ribbon rollers, through the slots in the ribbon reverse levers, and through the ribbon guide on the type box carriage.

Make certain that the ribbon remains in the guide slots and that both reversing eyelets are between the ribbon spools and the reverse levers. Eliminate any slack in the ribbon.

#### 6. MULTIPLE COPIES.

The printing blow should not be heavier than that required to produce satisfactory copies. The printing spring adjusting bracket (figure 1-4) may be readily moved to any one of three notches. Use notch "1" for printing one to three copies with paper of usual weight, notch "2" for four or five copies, and notch "3" for six or more copies.

#### 7. STARTING PROCEDURE.

Controls which are frequently used are external to the Cabinet while those infrequently used are located on the Power Distribution Panel (figure 4-3) within the Cabinet, and on the inside of the cabinet dome (figure 1-12). Make sure that the cables from the Power Distribution Panel are plugged into their respective receptacles on the Automatic Typer and Keyboard.

*a.* The **LIGHT SWITCH** (three position), when in the ON position, causes the copy light to be operated by the electrical motor control mechanism and/or the power switch (provided that the copy light switch in the cabinet dome is ON). In the MAINT ON position, the light is on for maintenance purposes irrespective of the power switch position. With the switch in the OFF position (center), the light remains extinguished.

*b.* The **POWER SWITCH** (figure 4-3), when thrown to the upper position, applies power to the Teletypewriter and likewise to a Rectifier when used.

#### Note

Where delay mechanism on the Keyboard base is used to stop the motor on extended idling periods, the operator must press the **BREAK** key prior to transmission in order to restart the motors.

#### 8. SPEED SETTING.

Motor speed requires attention from the operator only when a governed motor is used, in which case, a speed indicator (120 vps tuning fork) is used for checking the motor speed. The rotating spots on the governor target appear stationary when viewed through the shutters of the vibrating fork if the Motor is on speed. An adjusting screw (figure 1-10) reached by a screw driver through an opening in the target adjusts motor speed. Stop the Motor and turn the screw clockwise to increase speed; counterclockwise to decrease it. The Motor may be considered on speed if not more than 12 spots pass a given point in ten seconds. As an aid in bringing the Motor approximately on speed, hold the repeat key and a char-

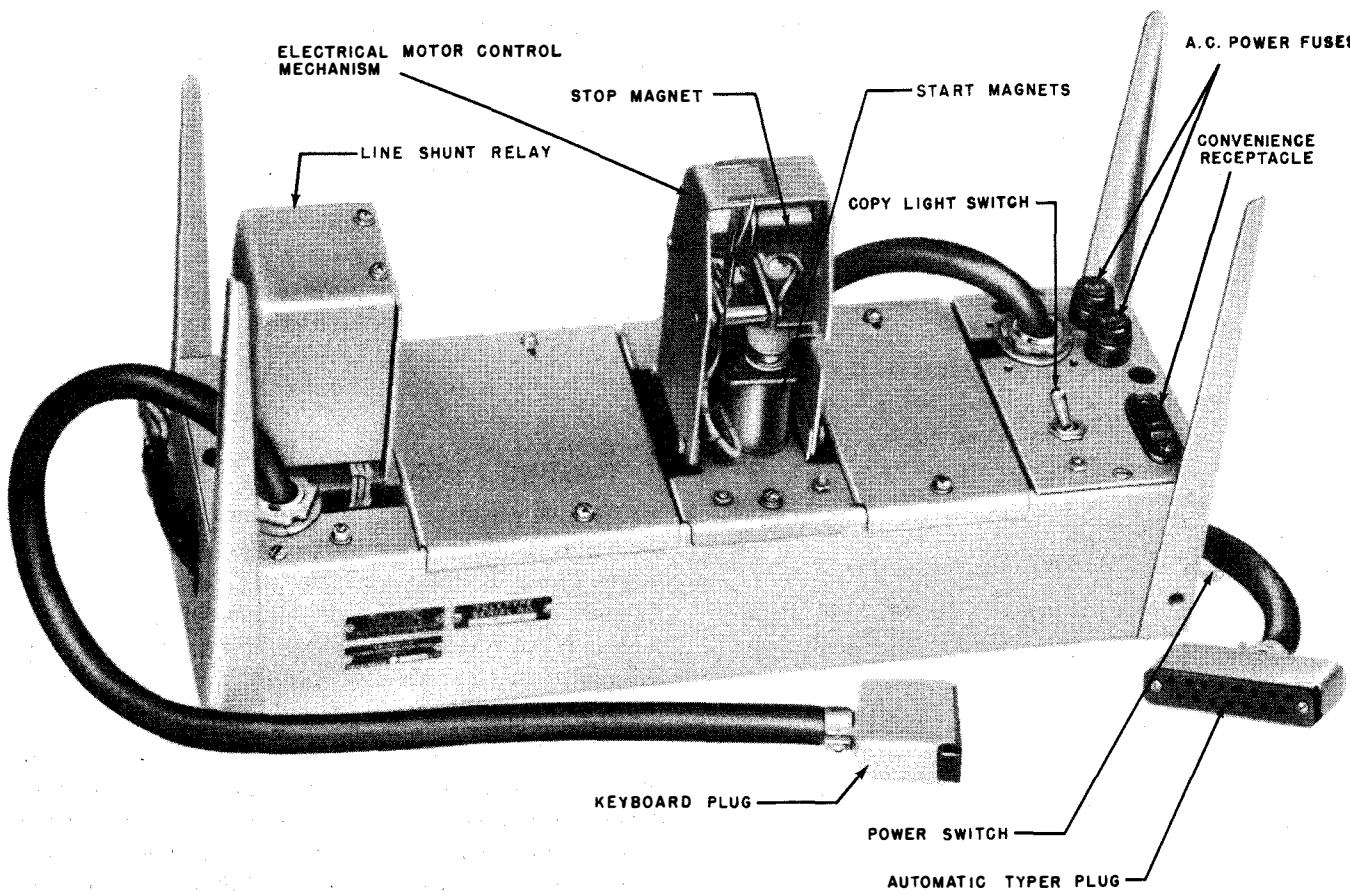


Figure 4-3. Power Distribution Panel SB-154/UG

acter key simultaneously operated. At 60-word speed, 60 characters should be typed in ten seconds; 100 characters for 100-word speed.

#### 9. ORIENTATION RANGE.

a. In order to utilize the receiving margin of the selecting mechanism to the best advantage, the starting position of the selector cam-clutch must be located at the most favorable angle. This is accomplished by positioning the clutch stop arm (figure 7-40) by means of the thumb screw on the range scale.

b. When available, a signal distortion test set should be used for orienting the range scale. Its final setting should be at the optimum position for bias in accordance with procedures outlined in the Teletype distributor bulletin applying to the test set. See section 7, paragraph 4.i.

c. When a signal distortion test set is not available, the orientation range can be best determined while receiving the characters RY from the distant station. Move the thumb screw in one direction until errors appear in the typed copy and then retract it slowly until the errors disappear. After noting this position,

move the thumb screw toward the opposite end of the scale and determine the other limit in a similar manner. The final setting should be midway between the determined limits.

d. When it is not feasible to determine the range scale setting by either the use of distortion test set or signals received from a distant station, it will be necessary to utilize transmission from the local Keyboard. In so doing, strike the R and Y keys alternately and determine the overall orientation range. Nominal ranges are 60 points for 60-word speed and 72 points for 100-word speed. For either speed, the final setting on a local basis should be 45 points above what is found to be the lower operating limit. Where no distortion test set is available this overall orientation range is the only means for determining the efficiency of the selector with regard to its adjustments.

#### 10. SUMMARY OF OPERATION.

a. Throw the POWER switch on the front of the cabinet to the ON position (upward). Allow several seconds to elapse in order for the Motors to attain running speeds and for the Rectifier, if used, to deliver current.

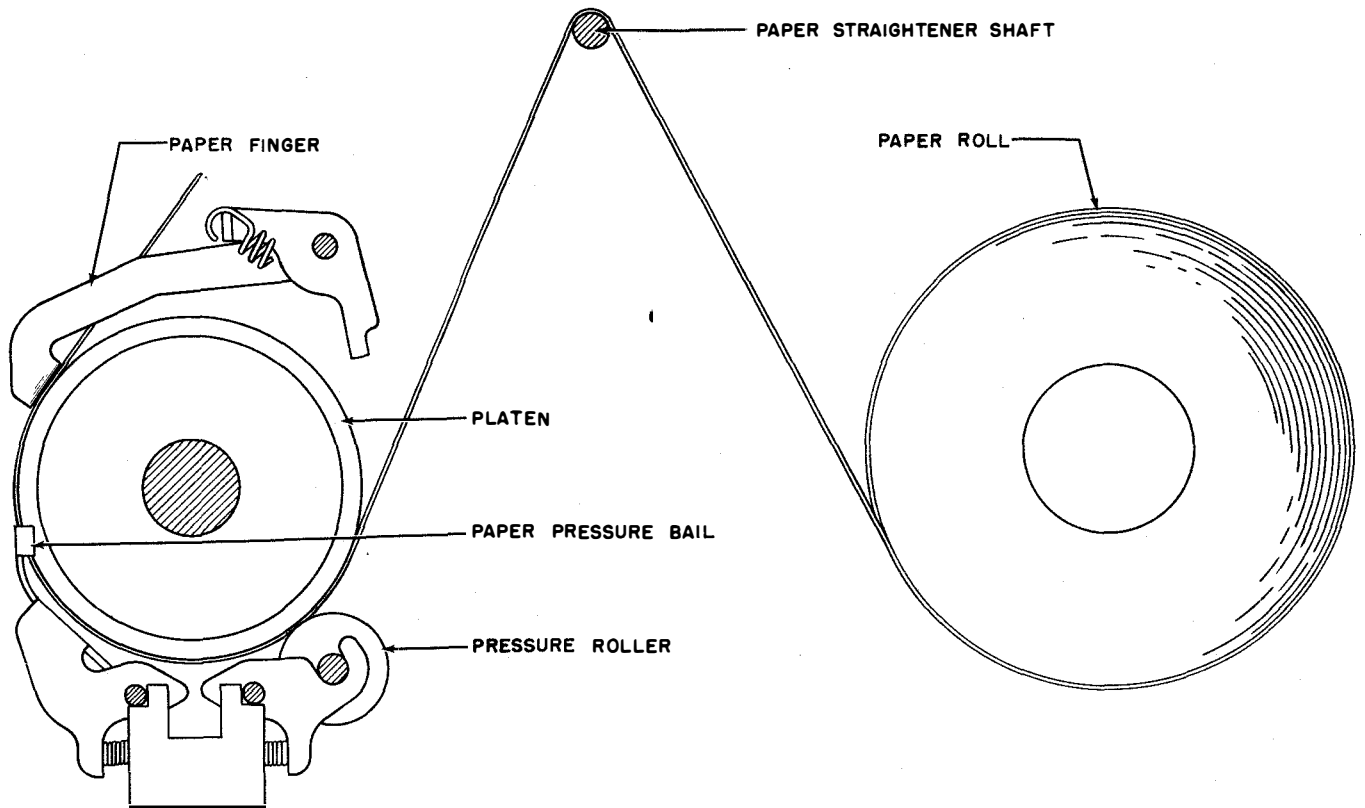


Figure 4-4. Path of Paper

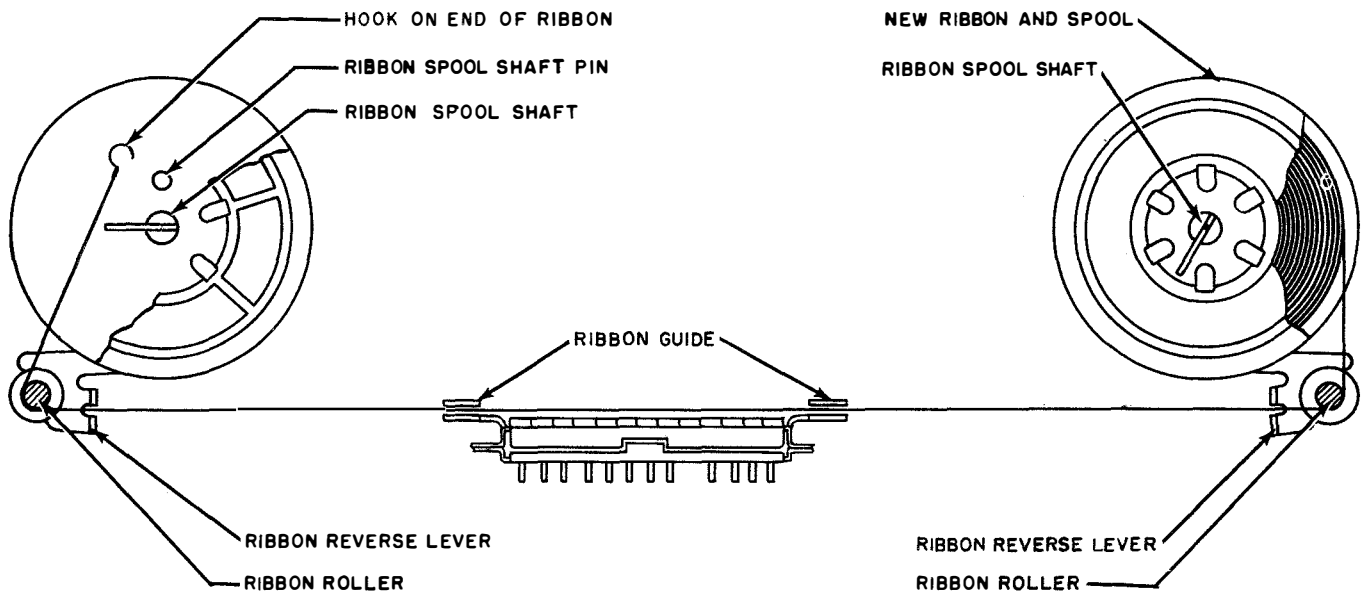


Figure 4-5. Path of Ribbon

**Paragraph 10.b.****TT-47/UG, TT-48/UG, TT-69/UG, TT-70/UG**

*b.* Hold the BREAK key depressed for at least two seconds to insure starting of the Motors (when controlled by a delay feature) and to lock the Keyboards on the circuit prior to starting transmission.

*c.* Press the KEYBOARD UNLOCK key to unlock the local Keyboard.

*d.* Press the CARRIAGE RETURN key to bring the carriages on all machines to the beginning of the line.

*e.* If the Motor is subject to stops by the delay feature, press the BREAK key prior to transmission in each instance where the circuit has been idle for one minute regardless of whether the Motor on the local machine has stopped or not.

*f.* To shut down the equipment throw the POWER switch to the OFF position (downward).

**11. OVERLOAD CUTOUT.**

The Synchronous Motor PD-17/U is equipped with a thermal cutout element to protect the Motor against any excessively high temperature which might develop

in case of a prolonged overload that would be insufficient to stall the Motor and blow the protecting fuses. Once operated, this cutout device must be reset manually by pressing a reset button (figure 1-9) (on the stator portion of the Motor) before it can be restarted.

**CAUTION**

If the Motor stops and does not restart in response to regularly operated controls, check fuses F-1101 and F-1102 in the Power Distribution Panel. If the fuses have not blown, check the Motor for excessive temperature. Where excessive temperature is indicated, rotate the Motor by hand to determine whether any abnormal mechanical condition is present. If the load appears normal, leave the cabinet dome raised and permit the temperature to drop before resetting the cutout feature. If the Motor continues to cutout or if any abnormal load conditions cannot be readily corrected, turn the equipment over to authorized maintenance personnel.

## SECTION 5 OPERATOR'S MAINTENANCE

### 1. ROUTINE CHECKS.

During normal operation, the printed copy of the message should be observed from time to time for indications of failure in the communication system. Additional checks should be made as indicated in table 5-1.

### 2. EMERGENCY MAINTENANCE.

#### NOTICE TO OPERATORS

Operators shall not perform any of the following emergency procedures without proper authorization.

*a.* FUSE LOCATIONS AND SYMPTOMS OF FAILURE.—Two cartridge-type fuses are located in the Power Distribution Panel and are accessible when the cabinet dome is raised. The fuse designations, cur-

rent ratings, and symptoms of failure are listed in table 5-2. Fuse locations appear in table 5-3.

### WARNING

Never replace a fuse with one of higher rating unless continued operation of the equipment is more important than probable damage. If a fuse burns out immediately after replacement, do not replace it a second time until the cause has been corrected.

*b.* REPLACEMENT OF LAMPS.—The end-of-line indicator lamp and the two lamps in the copy light assembly, all of which are mounted in the front of the cabinet dome, have the conventional miniature bayonet-type base. All are accessible when the dome is raised.

TABLE 5-1. ROUTINE CHECK CHART

WHAT TO CHECK	HOW TO CHECK	REMARKS
1. General operation	Each Watch Apply operating tests as detailed in section 3, paragraph 7.	If irregularities occur notify authorized maintenance personnel.
2. Paper supply	Daily Routines Replace roll if only a few turns remain on the spindle.	Be sure that paper is straight under paper fingers, and that release lever is forward.
3. Condition of ribbon	Change if copy is too light.	Be sure that ribbon is in guides on type box and ribbon reversing levers.
4. Condition of type	If smudging is evident, remove the type box and clean the type by means of a stiff brush.	Be sure that type box is securely attached and that ribbon is not disturbed.
5. Condition of cover glass	Clean if required by means of soft cloth.	Make sure that paper or ribbon is not disturbed.
6. Orientation range	Quarterly Routines Note should be made of the pointer setting on the range scale so that if it is disturbed for any reason it can be repositioned conveniently. If a further check is necessary see section 4, paragraph 9.	Abnormal signal line conditions may require changes in the setting as an expediency. When normal line conditions are restored, normal setting should be re-established.
7. Motor speed	Check with speed indicator (120 vps tuning fork). Motor may be considered on-speed if not more than 12 target spots pass a given point in ten seconds.	Applies to governed motors only. To adjust, turn the governor adjusting screw (fig. 1-10) in the direction indicated by the stamping on the governor cover.



TABLE 5-2. SYMPTOMS OF FUSE FAILURE

MOTOR	MAINTENANCE LIGHT	CONVENIENCE RECEPTACLE	BLOWN FUSE	VALUE (AMPS.)	COMMENTS
OFF	OUT	Dead	F-1101	10	In Power Distribution Panel
OFF	OUT	Dead	F-1102	10	In Power Distribution Panel

TABLE 5-3. FUSE LOCATIONS

SYMBOL	LOCATION	PROTECTS	AMPS.	VOLTS	NUMBER
F-1101	Power Distribution Panel	AC Supply	10	250	ABC-10
F-1102	Power Distribution Panel	AC Supply	10	250	ABC-10

## SECTION 6 PREVENTIVE MAINTENANCE

### 1. GENERAL.

*a.* Preventive maintenance is applied for the purpose of detecting and correcting troubles before they develop to the point of interference with the satisfactory operation of the equipment. Use care to prevent the introduction of trouble when work on the equipment is necessary. Do not disturb the adjustments unnecessarily.

*b.* A thorough visual examination of the equipment during periodic checks may uncover conditions that could possibly cause trouble later. The appearance of oxidized (red) metal dust adjacent to any bearing surface may indicate insufficient lubrication. The adjustable clearances of working parts should also be observed. A visual examination should be accompanied by a manual one. Connections at terminal board should be tested for tightness. Nuts and screws that lock adjustable features should be carefully observed for looseness and tightness if necessary. While cleaning the units, care should be exercised to avoid damage or distortion to delicate springs that might weaken their tension.

#### Note

The attention of maintenance personnel is invited to the requirements of Chapter 67 of

the Bureau of Ships Manual, of the latest issue.

### 2. ROUTINE MAINTENANCE CHECK CHARTS.

Routine maintenance checks of the Teletypewriters shall be performed as directed in table 6-1.

### 3. LUBRICATION.

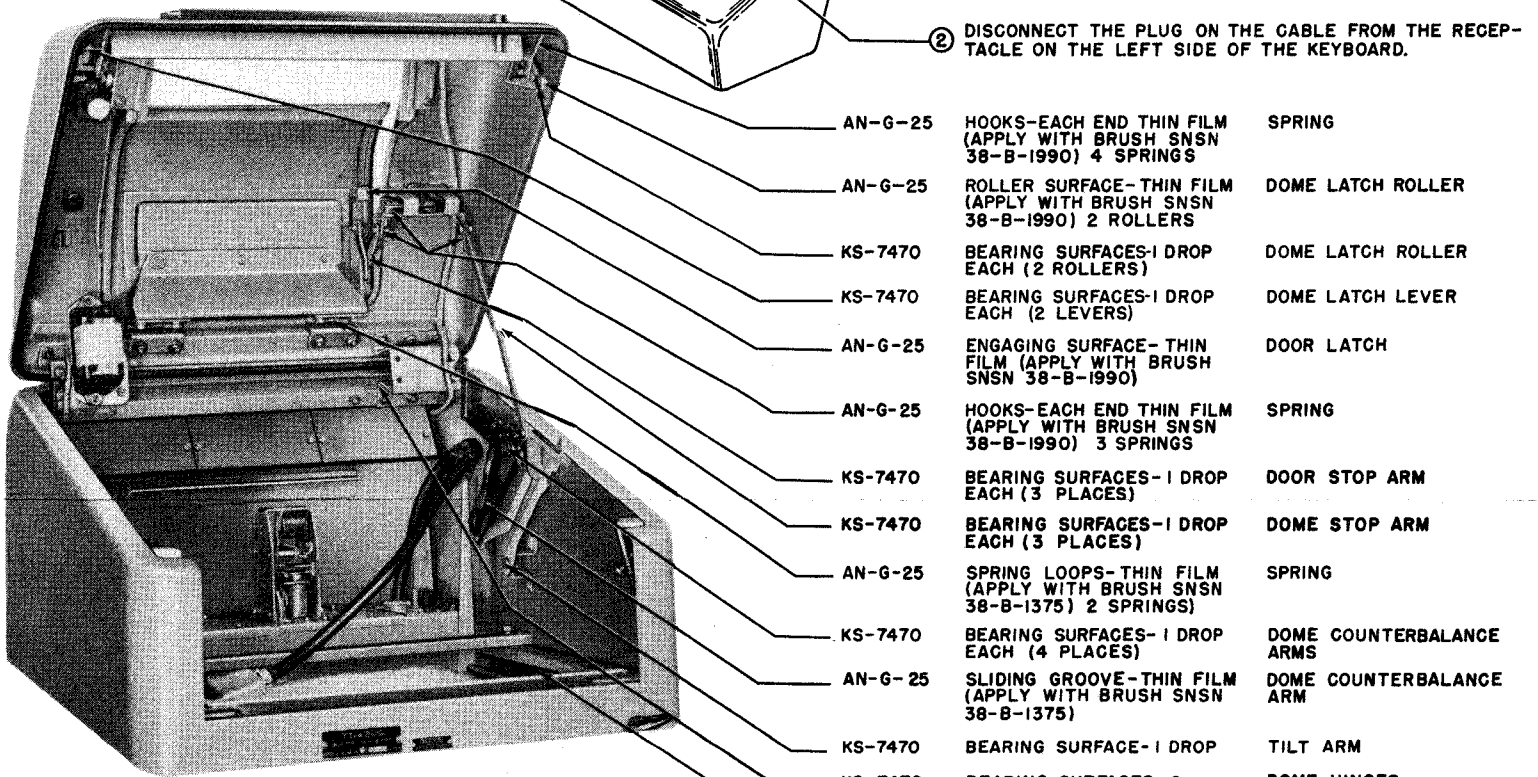
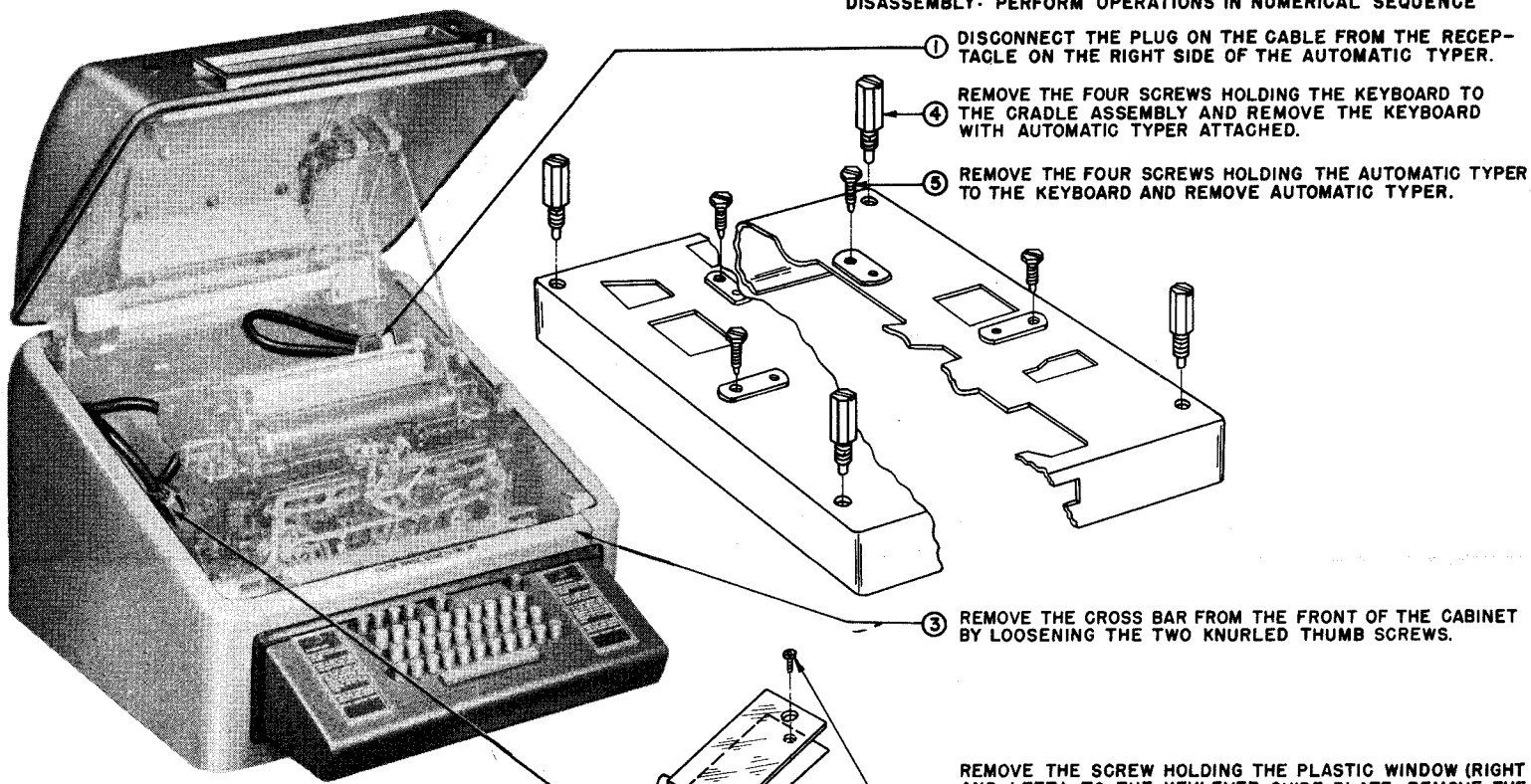
Lubricate the Teletypewriter as directed in figures 6-1 through 6-17 inclusive. These figures indicate the lubrication interval, the points to be lubricated, and the type and quantity of lubricant to be used. At 60-word speed, lubricate the Teletypewriter every four months. At 75-word speed, lubricate every three months. At 100-word speed, lubricate every two months. For normal or high temperatures — 5° to 55° C. (41° to 131° F.), use Teletype KS-7470 oil at all locations where the use of oil is indicated. For lower temperatures dilute the KS-7470 oil with kerosene (half and half). Use type AN-G-25 grease on all surfaces where grease is indicated except the motor bearings. Apply two drops of KS-7470 oil to motor bearings every four months (depress oiler with metal object). If the motor is disassembled at any time, repack the bearings with AN-G-25 grease.

TABLE 6-1. ROUTINE MAINTENANCE CHECK CHART

WHAT TO CHECK	HOW TO CHECK	PRECAUTIONS
1. Accumulation of dust and dirt.	<i>Quarterly Routines</i> Check for dust from paper beneath its path through typer and for dust and dirt on other parts of the equipment. Clean by wiping with a soft lint-free cloth. Cleaning with an air hose should be avoided.	Be sure that springs are not disengaged or other parts disturbed in cleaning. Avoid getting dust or dirt into bearings or other moving parts.
2. Selector response.	If the selector responds to distorted signals in the manner specified in section 7, paragraph 4.i. no maintenance is required. See section 4, paragraph 9. If the requirements are not met the following routine should be observed: a. Clean the magnet pole faces by running a clean piece of paper between them and the armature. b. Examine selector parts for wear and replace if worn. c. Check adjustment of selector mechanism. See figures 7-31, 7-32, 7-33. d. Check selector mechanism springs and replace if necessary.	Be sure that thumb screw on range scale is securely tightened.
3. Adjustments.	Most adjustments will remain within specification limits for the life of the equipment and, therefore, do not require checking unless trouble occurs. The following adjustments should be checked and remade if necessary. a. Dashpot, figure 7-64. b. Carriage wire rope, figure 7-60. c. Signal generator contact, figure 7-10. d. All clutches, figures 7-47, 7-48.	Exercise extreme precaution to guard against overtightening screws which might result in stripping.
4. Motor brushes.	Remove and replace if length is less than $\frac{3}{8}$ inch. Wipe and blow off the accumulation of carbon dust.	Relationship of brush to armature should be maintained (governed motors only).
5. Governor brushes.	Examine length and replace if less than $\frac{3}{8}$ inch remains. Wipe and blow off accumulation of carbon dust.	Be sure brush springs are in place (governed motors only).
6. Governor contacts.	Replace if badly burned.	Be sure that contacts are properly aligned.
7. Governor speed.	See section 4, paragraph 8.	Applies to governed motor only. Motor may be considered on-speed if not more than 12 target spots pass a given point in ten seconds.
8. Lubrication.	For disassembly prior to lubrication, see instructions in figure 6-1. Remove the typer from the keyboard. Examine all of its mechanism for signs of lubrication failure usually evidenced by the presence of red powdery substance at point of failure. If failure is observed, parts should be examined and if damaged they should be replaced. Lubricate the equipment in accordance with paragraph 3 of this section and wipe off excessive lubricant with a clean cloth.	Be sure that springs are not disengaged and that other parts are not disturbed during examination and lubrication.

CABINETS CY-870/UG & CY-871/UG

DISASSEMBLY: PERFORM OPERATIONS IN NUMERICAL SEQUENCE



- AN-G-25 HOOKS-EACH END THIN FILM (APPLY WITH BRUSH SNSN 38-B-1990) 4 SPRINGS SPRING
- AN-G-25 ROLLER SURFACE-THIN FILM (APPLY WITH BRUSH SNSN 38-B-1990) 2 ROLLERS DOME LATCH ROLLER
- KS-7470 BEARING SURFACES-1 DROP EACH (2 ROLLERS) DOME LATCH ROLLER
- KS-7470 BEARING SURFACES-1 DROP EACH (2 LEVERS) DOME LATCH LEVER
- AN-G-25 ENGAGING SURFACE-THIN FILM (APPLY WITH BRUSH SNSN 38-B-1990) DOOR LATCH
- AN-G-25 HOOKS-EACH END THIN FILM (APPLY WITH BRUSH SNSN 38-B-1990) 3 SPRINGS SPRING
- KS-7470 BEARING SURFACES-1 DROP EACH (3 PLACES) DOOR STOP ARM
- KS-7470 BEARING SURFACES-1 DROP EACH (3 PLACES) DOME STOP ARM
- AN-G-25 SPRING LOOPS-THIN FILM (APPLY WITH BRUSH SNSN 38-B-1375) 2 SPRINGS SPRING
- KS-7470 BEARING SURFACES-1 DROP EACH (4 PLACES) DOME COUNTERBALANCE ARMS
- AN-G-25 SLIDING GROOVE-THIN FILM (APPLY WITH BRUSH SNSN 38-B-1375) DOME COUNTERBALANCE ARM
- KS-7470 BEARING SURFACE-1 DROP TILT ARM
- KS-7470 BEARING SURFACES-2 DROPS EACH (2 HINGES) DOME HINGES
- AN-G-25 HOOKS-EACH END THIN FILM (APPLY WITH BRUSH SNSN 38-B-1375) SPRING

**CAUTION:** Wipe off excessive lubricant. Do not distort or disturb springs.

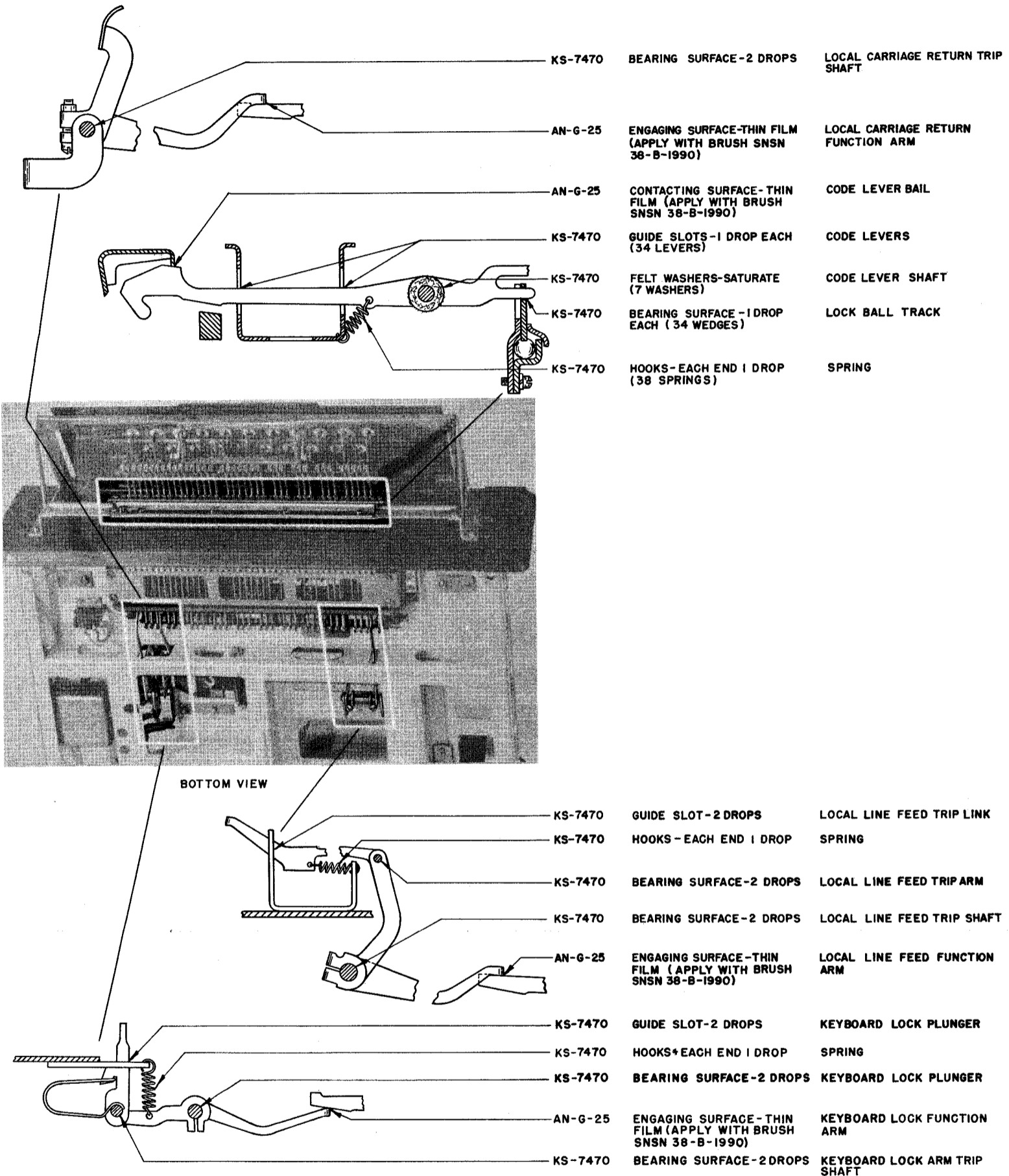
**Notes:** 1. Interval—four months at 60-wpm; three months at 75-wpm; two months at 100-wpm.  
2. Use type KS-7470 oil as supplied for normal or high temperatures —5° to +55° C. (41° to 131° F.). For lower temperatures, dilute the KS-7470 with kerosene (half and half).

NAVY LUBRICANT		STANDARD NAVY STOCK NUMBER									
SPECIFICATION	TITLE	1 PT.	1 QT.	1 GAL.	5 GAL.	8 OZS.	1 LB.	5 LB.	25 LB.	35 LB.	100 LB.
Teletype KS-7470	Lubricating oil	N17-T-350011-463	N17-T-350002-878	N17-T-350009-698							
AN-G-25	Lubricating grease					R14-G-984-500	R14-G-982-20	R14-G-984-520	R14-G-984-540	R14-G-984-550	R14-G-984-560
VV-K-211	Kerosene				W7-K-505						

Figure 6-1. Lubrication Data  
Cabinets CY-870/UG and CY-871/UG

# KEYBOARD MX-1114/UG

REST KEYBOARD BOTTOM SIDE UPWARD



**CAUTION:** Wipe off excessive lubricant. Do not distort or disturb springs.

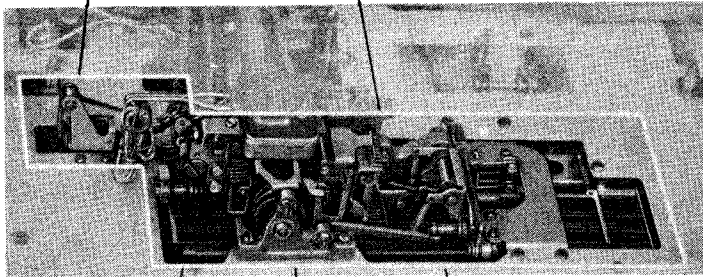
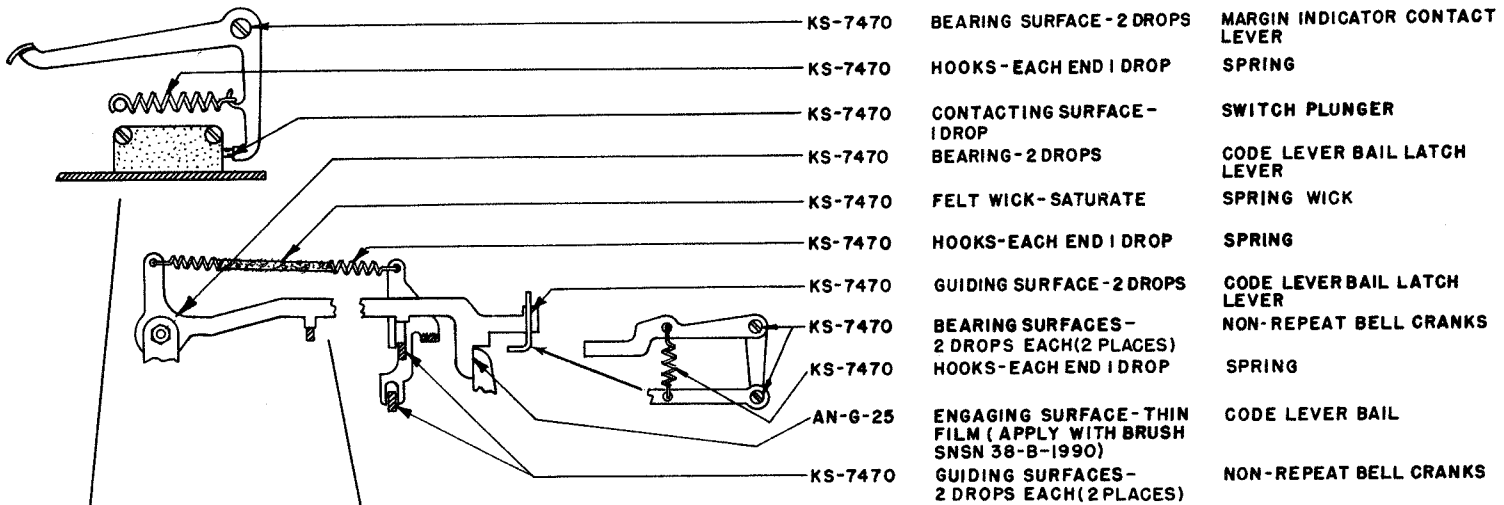
- Notes:**
- Interval—four months at 60-wpm; three months at 75-wpm; two months at 100-wpm.
  - Use type KS-7470 oil as supplied for normal or high temperatures —5° to +55° C. (41° to 131° F.). For lower temperatures, dilute the KS-7470 with kerosene (half and half).

NAVY LUBRICANT		STANDARD NAVY STOCK NUMBER									
SPECIFICATION	TITLE	1 PT.	1 QT.	1 GAL.	5 GAL.	8 OZS.	1 LB.	5 LB.	25 LB.	35 LB.	100 LB.
Teletype KS-7470	Lubricating oil	N17-T-350011-463	N17-T-350002-878	N17-T-350009-698							
AN-G-25	Lubricating grease					R14-G-984-500	R14-G-982-20	R14-G-984-520	R14-G-984-540	R14-G-984-550	R14-G-984-560
VV-K-211	Kerosene				W7-K-505						

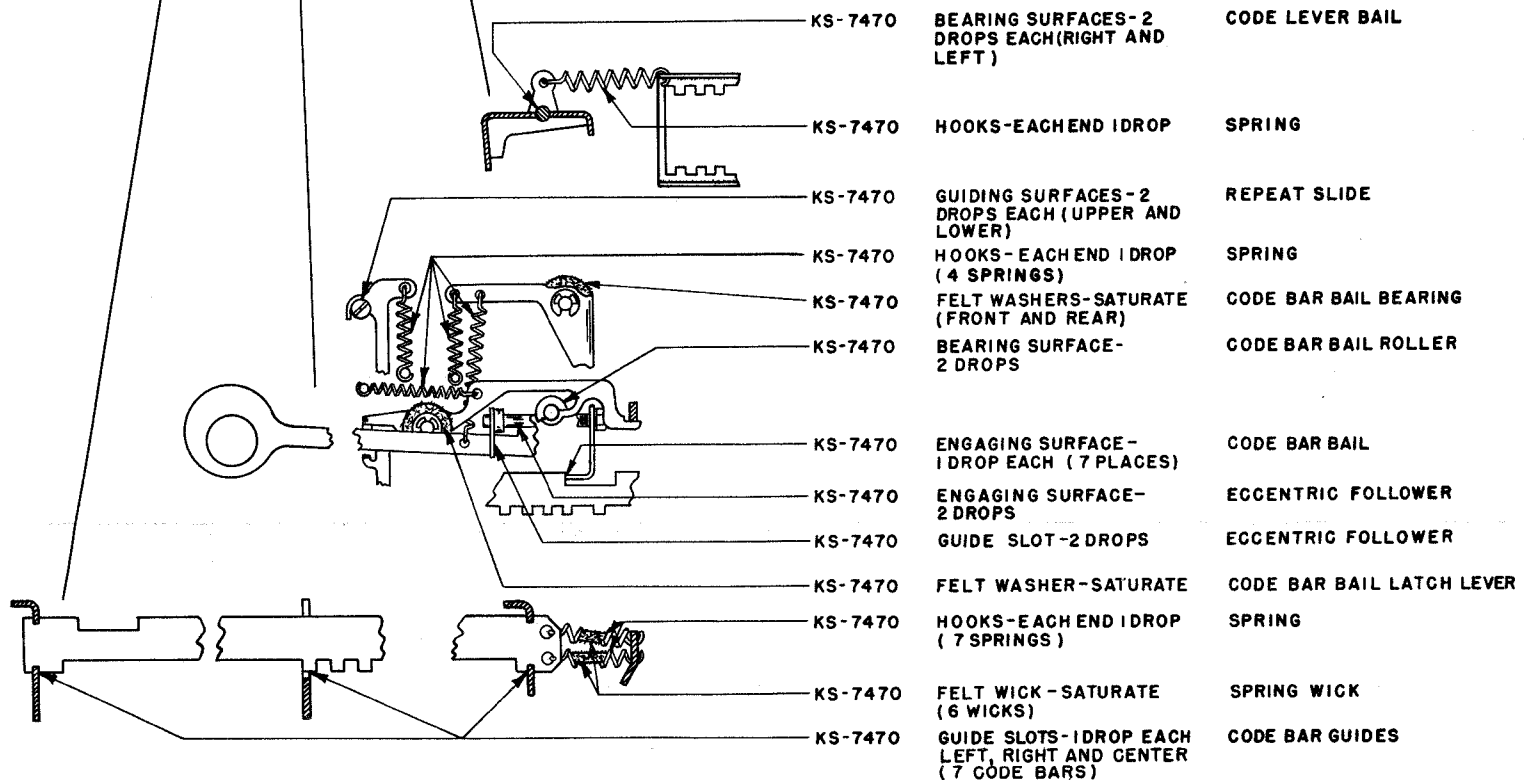
Figure 6-2. Lubrication Data  
Keyboard MX-1114/UG

KEYBOARD MX-1114/UG

REST KEYBOARD IN UPRIGHT POSITION



TOP VIEW



**CAUTION:** Wipe off excessive lubricant. Do not distort or disturb springs.

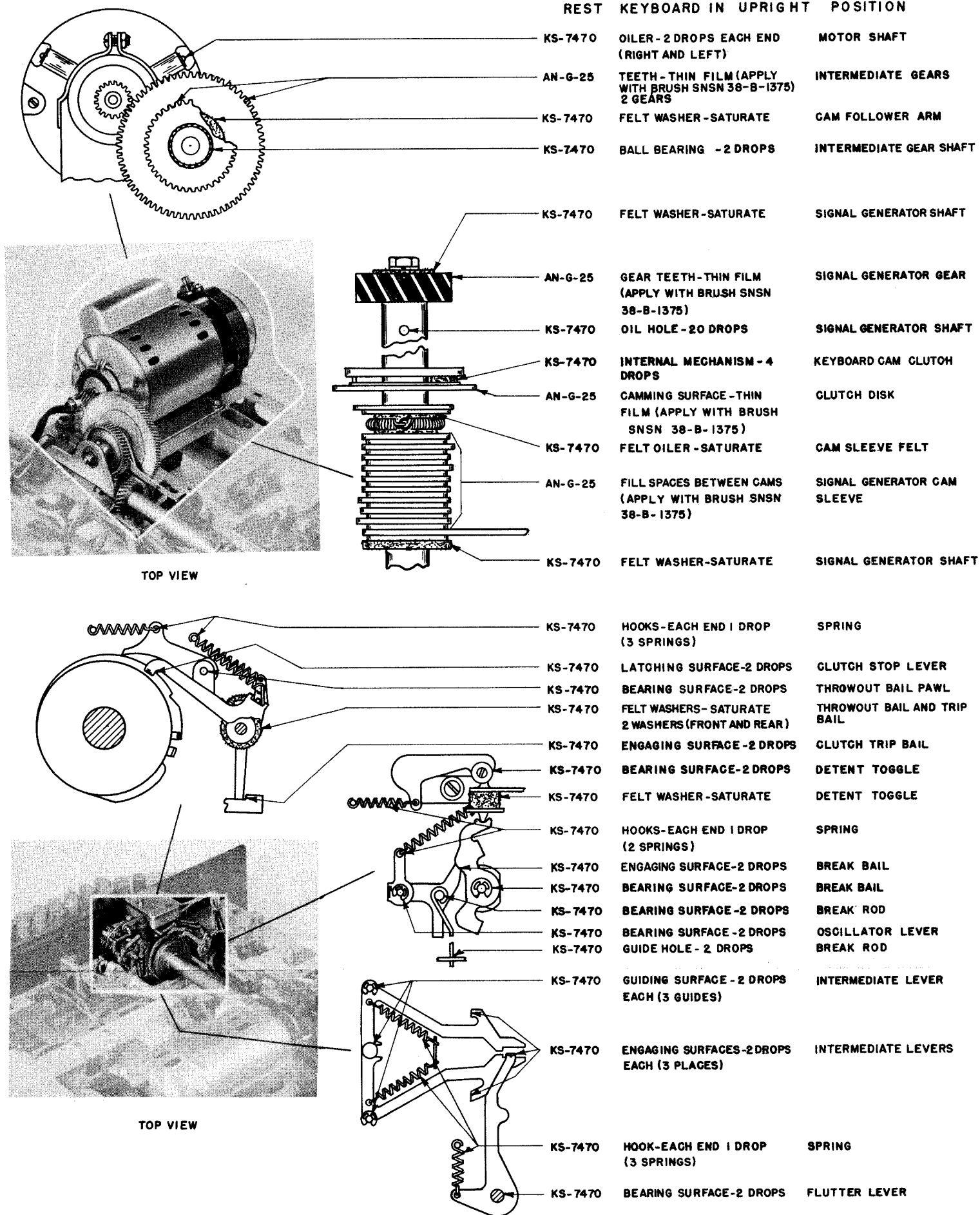
- Notes:** 1. Interval—four months at 60-wpm; three months at 75-wpm; two months at 100-wpm.  
 2. Use type KS-7470 oil as supplied for normal or high temperatures —5° to +55° C. (41° to 131° F.). For lower temperatures, dilute the KS-7470 with kerosene (half and half).

NAVY LUBRICANT		STANDARD NAVY STOCK NUMBER									
SPECIFICATION	TITLE	1 PT.	1 QT.	1 GAL.	5 GAL.	8 OZS.	1 LB.	5 LB.	25 LB.	35 LB.	100 LB.
Teletype KS-7470	Lubricating oil	N17-T-350011-463	N17-T-350002-878	N17-T-350009-698							
AN-G-25	Lubricating grease					R14-G-984-500	R14-G-982-20	R14-G-984-520	R14-G-984-540	R14-G-984-550	R14-G-984-560
VV-K-211	Kerosene				W7-K-505						

Figure 6-3. Lubrication Data  
Keyboard MX-1114/UG

KEYBOARD MX-1114/UG

REST KEYBOARD IN UPRIGHT POSITION



**CAUTION:** Wipe off excessive lubricant. Do not distort or disturb springs.

- Notes:**
- Interval—four months at 60-wpm; three months at 75-wpm; two months at 100-wpm.
  - Use type KS-7470 oil as supplied for normal or high temperatures  $-5^{\circ}$  to  $+55^{\circ}$  C. ( $41^{\circ}$  to  $131^{\circ}$  F.). For lower temperatures, dilute the KS-7470 with kerosene (half and half).

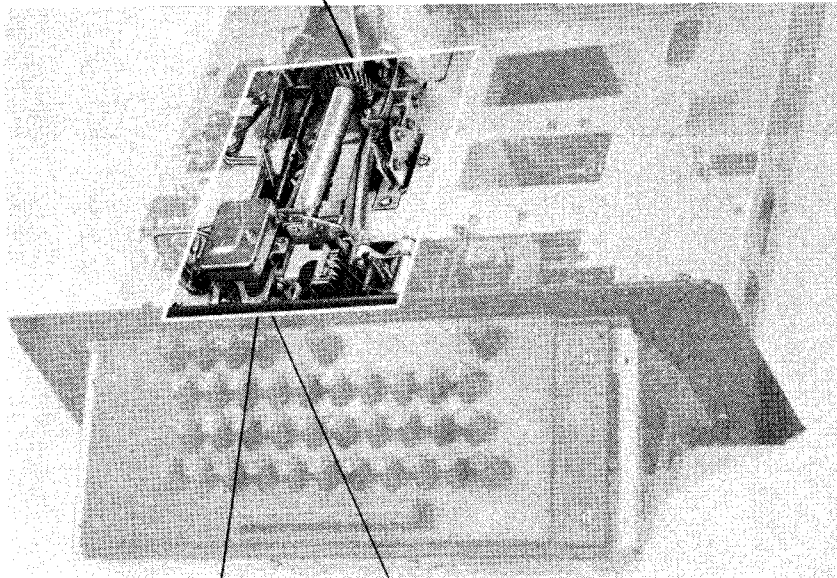
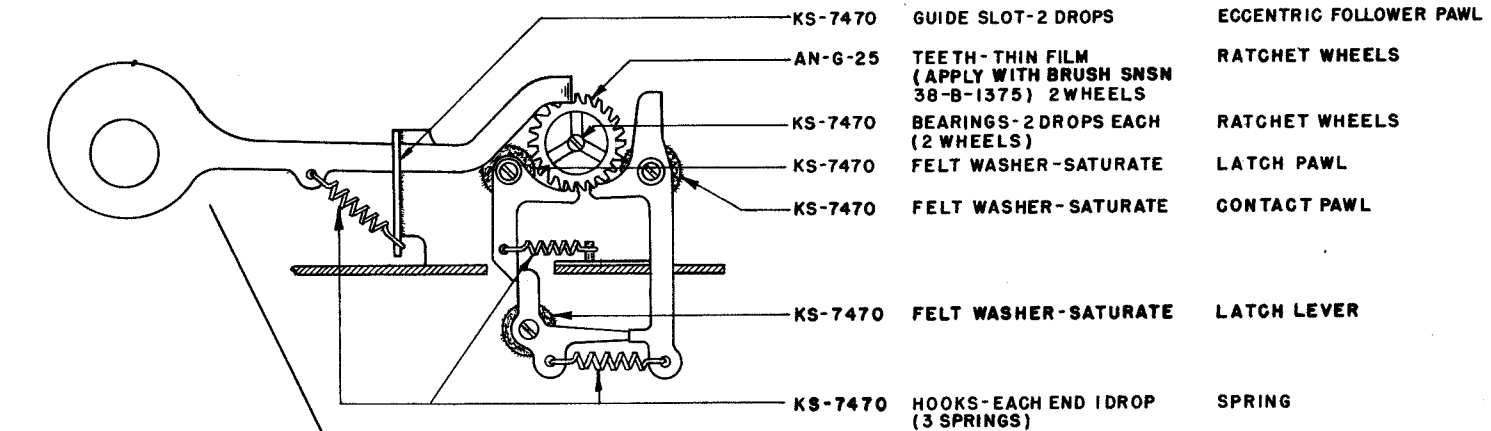
NAVY LUBRICANT		STANDARD NAVY STOCK NUMBER									
SPECIFICATION	TITLE	1 PT.	1 QT.	1 GAL.	5 GAL.	8 OZS.	1 LB.	5 LB.	25 LB.	35 LB.	100 LB.
Teletype KS-7470	Lubricating oil	N17-T-350011-463	N17-T-350002-878	N17-T-350009-698							
AN-G-25	Lubricating grease					R14-G-984-500	R14-G-982-20	R14-G-984-520	R14-G-984-540	R14-G-984-550	R14-G-984-560
VV-K-211	Kerosene				W7-K-505						

Figure 6-4. Lubrication Data

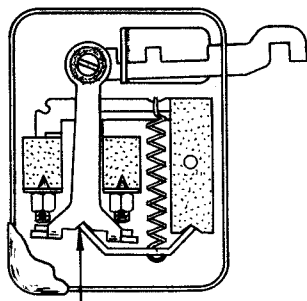
Keyboard MX-1114/UG

KEYBOARD MX-1114/UG

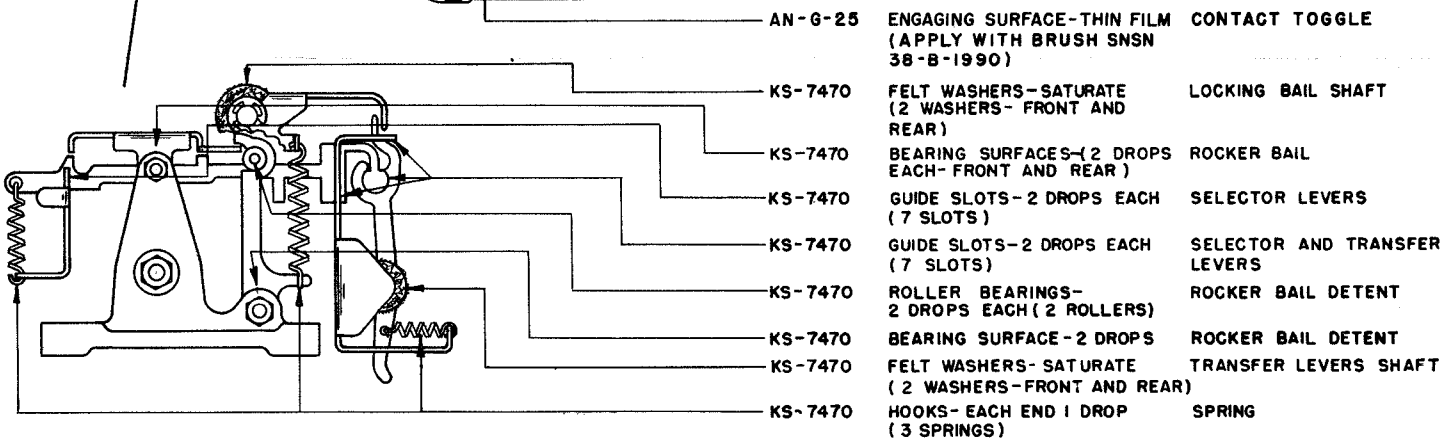
REST KEYBOARD IN UPRIGHT POSITION



TOP VIEW



DISASSEMBLY: REMOVE NUT AND LOCK WASHER SECURING CONTACT BOX COVER AND REMOVE COVER



CAUTION: Wipe off excessive lubricant. Do not distort or disturb springs.

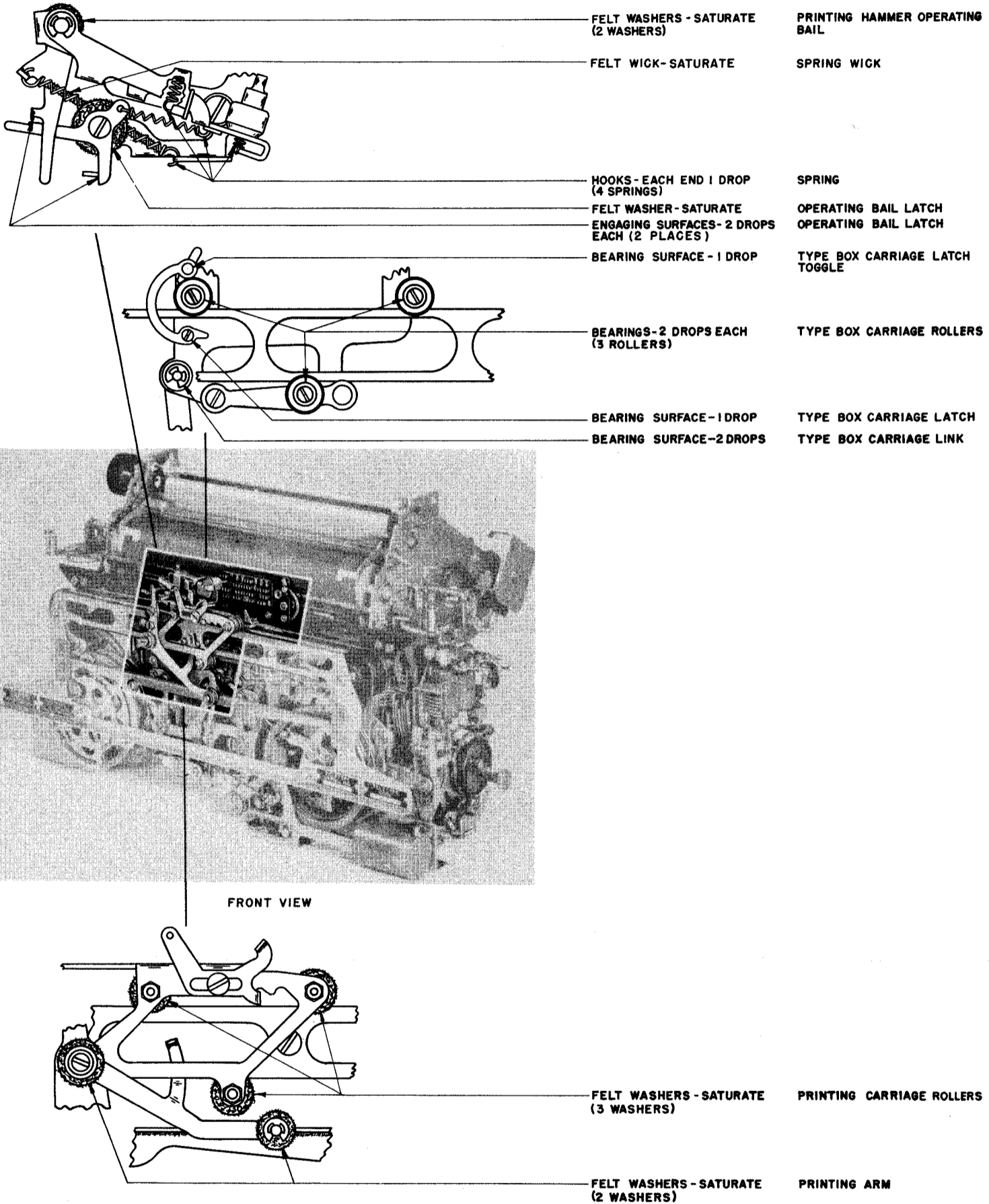
- Notes: 1. Interval—four months at 60-wpm; three months at 75-wpm; two months at 100-wpm.  
 2. Use type KS-7470 oil as supplied for normal or high temperatures  $-5^{\circ}$  to  $+55^{\circ}$  C. ( $41^{\circ}$  to  $131^{\circ}$  F.). For lower temperatures, dilute the KS-7470 with kerosene (half and half).

NAVY LUBRICANT		STANDARD NAVY STOCK NUMBER									
SPECIFICATION	TITLE	1 PT.	1 QT.	1 GAL.	5 GAL.	8 OZS.	1 LB.	5 LB.	25 LB.	35 LB.	100 LB.
Teletype KS-7470	Lubricating oil	N17-T-350011-463	N17-T-350002-878	N17-T-350009-698							
AN-G-25	Lubricating grease					R14-G-984-500	R14-G-982-20	R14-G-984-520	R14-G-984-540	R14-G-984-550	R14-G-984-560
VV-K-211	Kerosene				W7-K-505						



**AUTOMATIC TYPER MX-1115/UG**

**AUTOMATIC TYPER IN UPRIGHT POSITION**



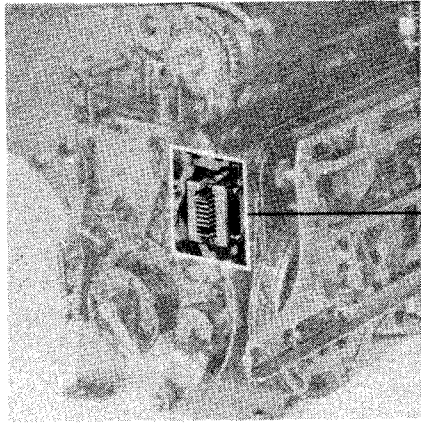
**CAUTION:** Wipe off excessive lubricant. Do not distort or disturb springs.

- Notes:**
- Interval—four months at 60-wpm; three months at 75-wpm; two months at 100-wpm.
  - All lubricant is type KS-7470. Use as supplied for normal or high temperatures  $-5^{\circ}$  to  $+55^{\circ}$  C. ( $41^{\circ}$  to  $131^{\circ}$  F.). For lower temperatures, dilute the KS-7470 oil with kerosene (half and half).

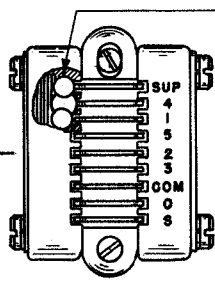
NAVY LUBRICANT		STANDARD NAVY STOCK NUMBER									
SPECIFICATION	TITLE	1 PT.	1 QT.	1 GAL.	5 GAL.	8 OZS.	1 LB.	5 LB.	25 LB.	35 LB.	100 LB.
Teletype KS-7470	Lubricating oil	N17-T-350011-463	N17-T-350002-878	N17-T-350009-698							
AN-G-25	Lubricating grease					R14-G-984-500	R14-G-982-20	R14-G-984-520	R14-G-984-540	R14-G-984-550	R14-G-984-560
VV-K-211	Kerosene				W7-K-505						

# AUTOMATIC TYPER MX-1115/UG

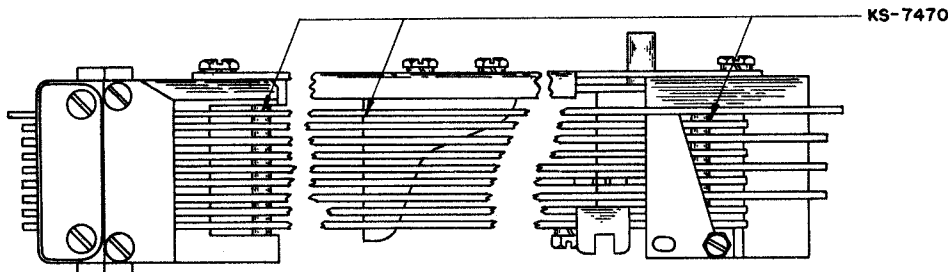
REST AUTOMATIC TYPER IN UPRIGHT POSITION



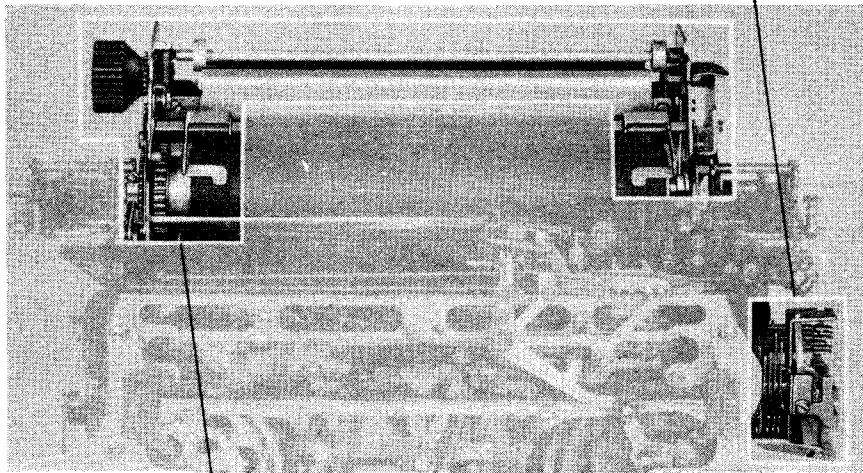
LEFT SIDE VIEW



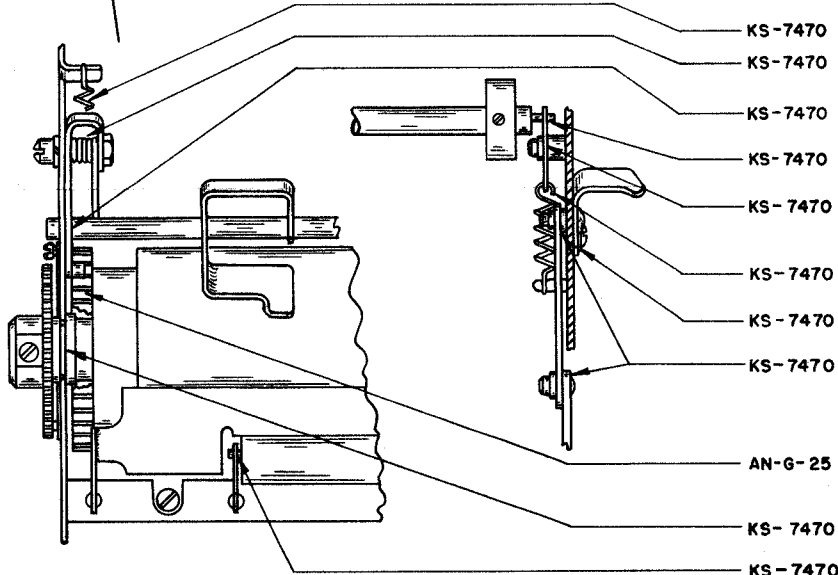
KS-7470 BEARING BALLS - 2 DROPS CODE BAR DETENT EACH (9 BALLS)



KS-7470 GUIDE SLOTS - 2 DROPS EACH (RIGHT, CENTER, AND LEFT) 9 BARS CODE BARS



FRONT VIEW



KS-7470 HOOKS - EACH END 1 DROP SPRING  
 KS-7470 BEARING SURFACE - 2 DROPS PLATEN DETENT BAIL  
 KS-7470 BEARING SURFACE - 2 DROPS (EACH END) PAPER FINGER SHAFT  
 KS-7470 BEARING SURFACE - 2 DROPS (EACH END) PAPER STRAIGHTENER SHAFT  
 KS-7470 BEARING SURFACES - 2 DROPS EACH (RIGHT AND LEFT) PAPER STRAIGHTENER LEVERS  
 KS-7470 HOOKS - EACH END 1 DROP SPRING  
 KS-7470 BEARING SURFACE - 2 DROPS RELEASE LEVER  
 KS-7470 BEARING SURFACES - 2 DROPS (EACH END) RELEASE LEVER LINK  
 AN-G-25 TEETH - THIN FILM (APPLY WITH BRUSH SNSN 38-B-1990) PLATEN GEAR  
 KS-7470 BEARINGS - 2 DROPS (EACH END) PLATEN SHAFT  
 KS-7470 BEARING SURFACE - 1 DROP EACH END (6 ROLLERS) PAPER PRESSURE ROLLER SHAFTS (WIPE OFF EXCESS OIL)

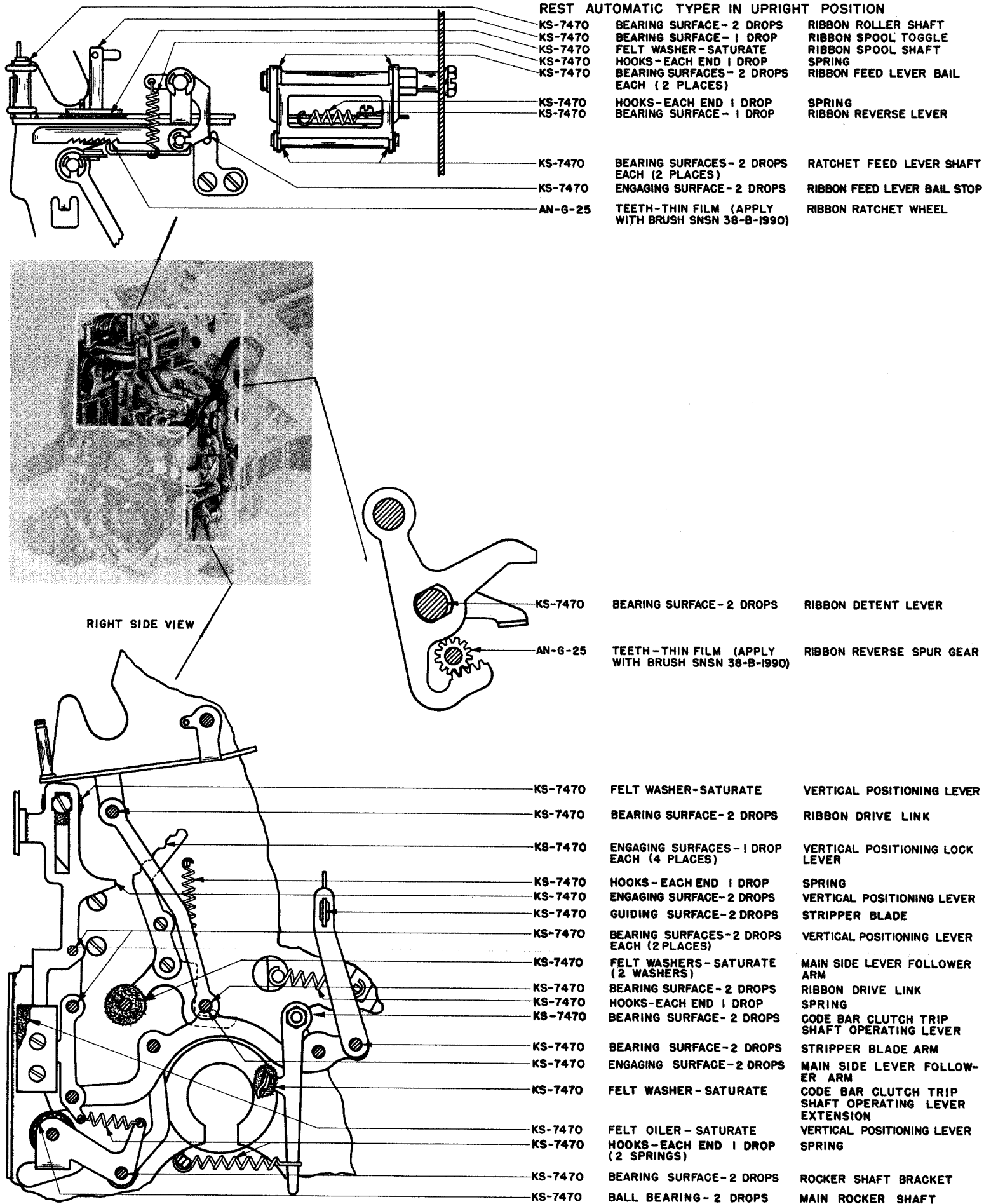
**CAUTION:** Wipe off excessive lubricant. Do not distort or disturb springs.

- Notes:**
- Interval—four months at 60-wpm; three months at 75-wpm; two months at 100-wpm.
  - Use type KS-7470 oil as supplied for normal or high temperatures —5° to +55° C. (41° to 131° F.). For lower temperatures, dilute the KS-7470 with kerosene (half and half).

NAVY LUBRICANT		STANDARD NAVY STOCK NUMBER									
SPECIFICATION	TITLE	1 PT.	1 QT.	1 GAL.	5 GAL.	8 OZS.	1 LB.	5 LB.	25 LB.	35 LB.	100 LB.
Teletype KS-7470	Lubricating oil	N17-T-350011-463	N17-T-350002-878	N17-T-350009-698							
AN-G-25	Lubricating grease					R14-G-984-500	R14-G-982-20	R14-G-984-520	R14-G-984-540	R14-G-984-550	R14-G-984-560
VV-K-211	Kerosene				W7-K-505						

Figure 6-7. Lubrication Data Automatic Typewriter MX-1115/UG

# AUTOMATIC TYPER MX-1115/UG



**CAUTION:** Wipe off excessive lubricant. Do not distort or disturb springs.

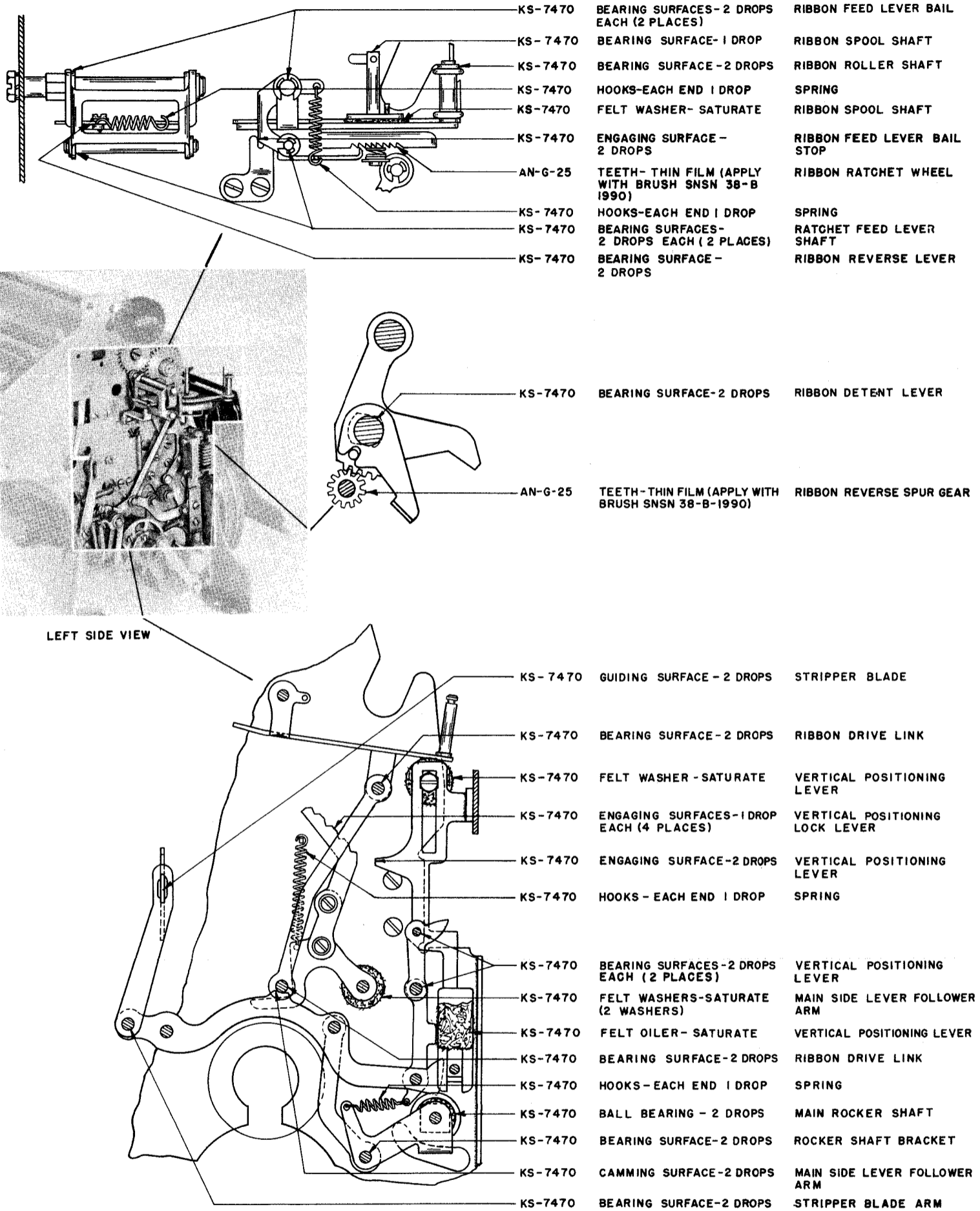
- Notes:**
- Interval—four months at 60-wpm; three months at 75-wpm; two months at 100-wpm.
  - Use type KS-7470 oil as supplied for normal or high temperatures —5° to +55° C. (41° to 131° F.). For lower temperatures, dilute the KS-7470 with kerosene (half and half).

NAVY LUBRICANT		STANDARD NAVY STOCK NUMBER									
SPECIFICATION	TITLE	1 PT.	1 QT.	1 GAL.	5 GAL.	8 OZS.	1 LB.	5 LB.	25 LB.	35 LB.	100 LB.
Teletype KS-7470	Lubricating oil	N17-T-350011-463	N17-T-350002-878	N17-T-350009-698							
AN-G-25	Lubricating grease					R14-G-984-500	R14-G-982-20	R14-G-984-520	R14-G-984-540	R14-G-984-550	R14-G-984-560
VV-K-211	Kerosene				W7-K-505						

Figure 6-8. Lubrication Data Automatic Typewriter MX-1115/UG

**AUTOMATIC TYPER MX-1115/UG**

REST AUTOMATIC TYPER IN UPRIGHT POSITION



**CAUTION:** Wipe off excessive lubricant. Do not distort or disturb springs.

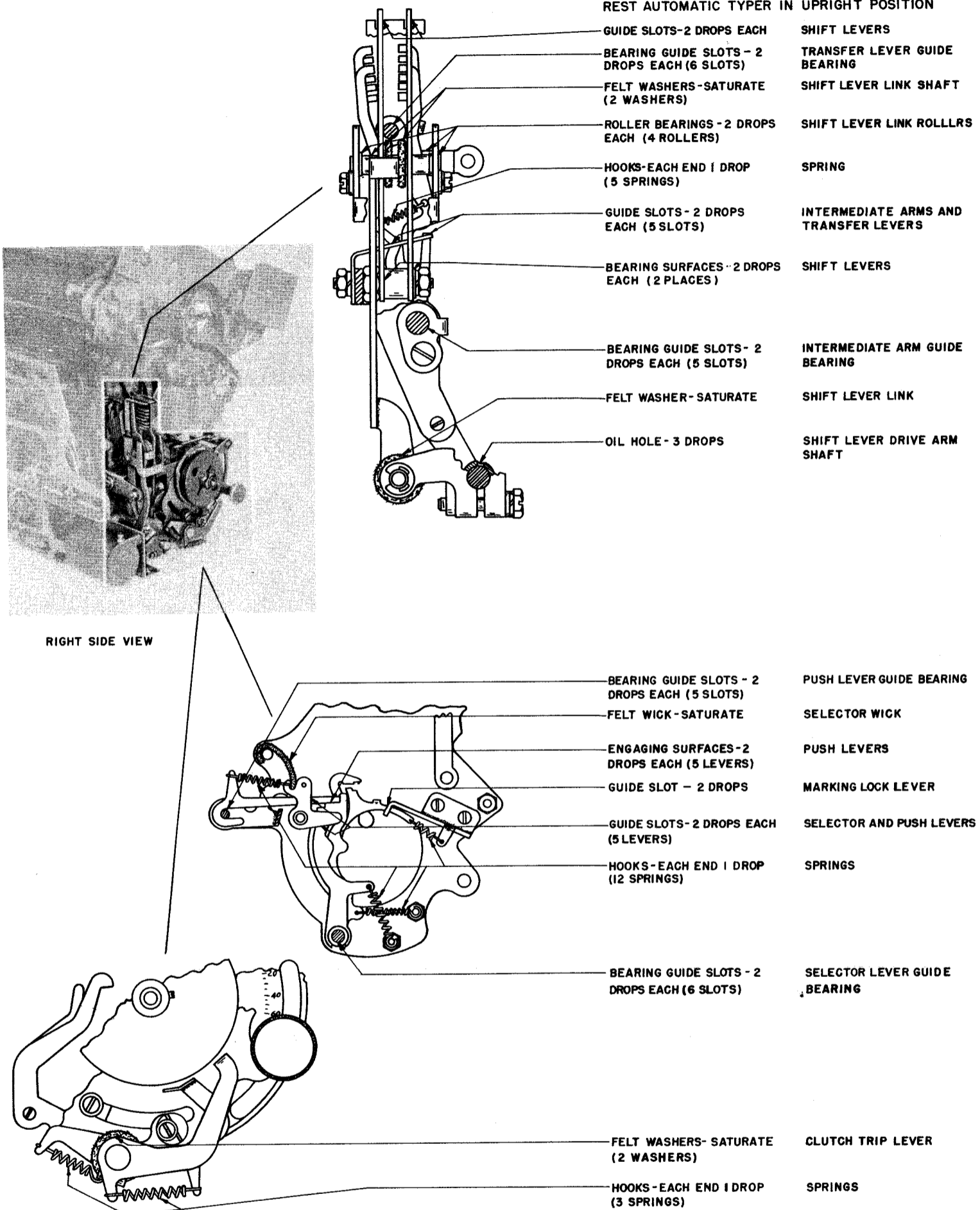
- Notes:**
- Interval—four months at 60-wpm; three months at 75-wpm; two months at 100-wpm.
  - Use type KS-7470 oil as supplied for normal or high temperatures  $-5^{\circ}$  to  $+55^{\circ}$  C. ( $41^{\circ}$  to  $131^{\circ}$  F.). For lower temperatures, dilute the KS-7470 with kerosene (half and half).

NAVY LUBRICANT		STANDARD NAVY STOCK NUMBER									
SPECIFICATION	TITLE	1 PT.	1 QT.	1 GAL.	5 GAL.	8 OZS.	1 LB.	5 LB.	25 LB.	35 LB.	100 LB.
Teletype KS-7470	Lubricating oil	N17-T-350011-463	N17-T-350002-878	N17-T-350009-698							
AN-G-25	Lubricating grease					R14-G-984-500	R14-G-982-20	R14-G-984-520	R14-G-984-540	R14-G-984-550	R14-G-984-560
VV-K-211	Kerosene				W7-K-505						

Figure 6-9. Lubrication Data  
Automatic Typewriter MX-1115/UG

### AUTOMATIC TYPER MX-1115/UG

REST AUTOMATIC TYPER IN UPRIGHT POSITION



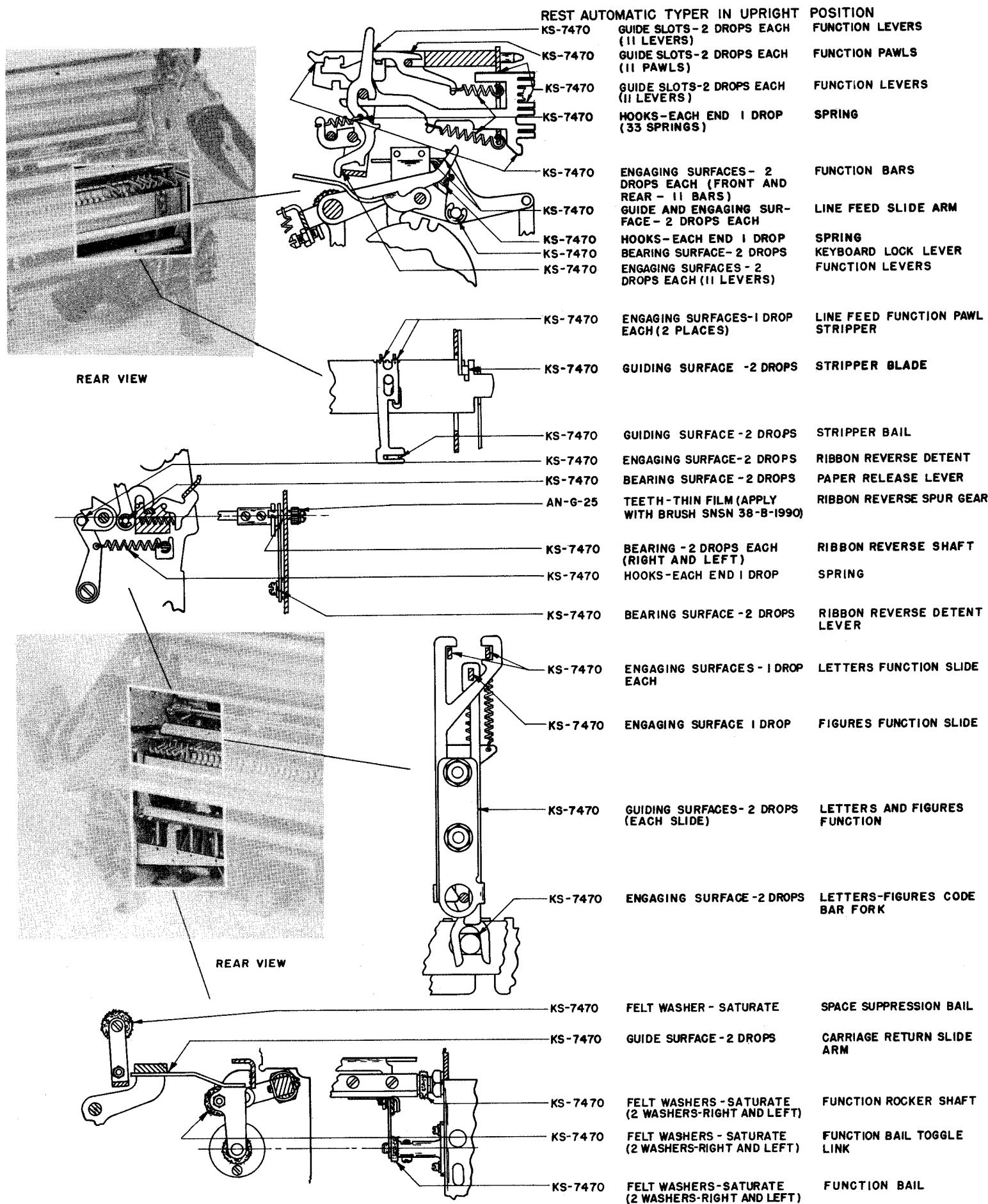
**CAUTION:** Wipe off excessive lubricant. Do not distort or disturb springs.

- Notes:**
- Interval—four months at 60-wpm; three months at 75-wpm; two months at 100-wpm.
  - All lubricant is type KS-7470. Use as supplied for normal or high temperatures —5° to +55° C. (41° to 131° F.). For lower temperatures, dilute the KS-7470 oil with kerosene (half and half).

NAVY LUBRICANT		STANDARD NAVY STOCK NUMBER									
SPECIFICATION	TITLE	1 PT.	1 QT.	1 GAL.	5 GAL.	8 OZS.	1 LB.	5 LB.	25 LB.	35 LB.	100 LB.
Teletype KS-7470	Lubricating oil	N17-T-350011-463	N17-T-350002-878	N17-T-350009-698							
AN-G-25	Lubricating grease					R14-G-984-500	R14-G-982-20	R14-G-984-520	R14-G-984-540	R14-G-984-550	R14-G-984-560
VV-K-211	Kerosene				W7-K-505						

Figure 6-10. Lubrication Data Automatic Typewriter MX-1115/UG

# AUTOMATIC TYPER MX-1115/UG



**CAUTION:** Wipe off excessive lubricant. Do not distort or disturb springs.

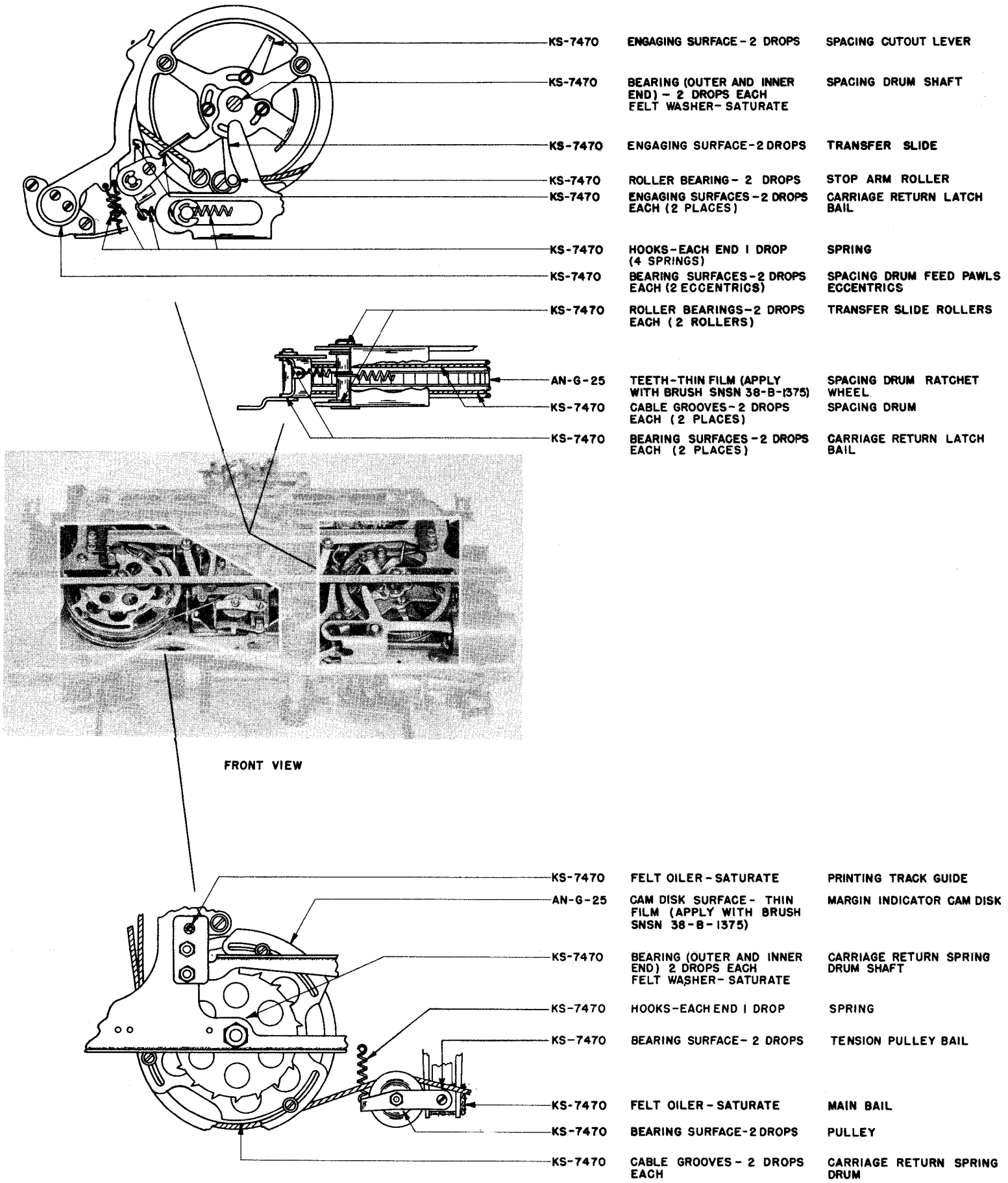
- Notes:**
- Interval—four months at 60-wpm; three months at 75-wpm; two months at 100-wpm.
  - Use type KS-7470 oil as supplied for normal or high temperatures -5° to +55° C. (41° to 131° F.). For lower temperatures, dilute the KS-7470 with kerosene (half and half).

NAVY LUBRICANT		STANDARD NAVY STOCK NUMBER									
SPECIFICATION	TITLE	1 PT.	1 QT.	1 GAL.	5 GAL.	8 OZS.	1 LB.	5 LB.	25 LB.	35 LB.	100 LB.
Teletype KS-7470	Lubricating oil	N17-T-350011-463	N17-T-350002-878	N17-T-350009-698							
AN-G-25	Lubricating grease					R14-G-984-500	R14-G-982-20	R14-G-984-520	R14-G-984-540	R14-G-984-550	R14-G-984-560
VV-K-211	Kerosene				W7-K-505						

Figure 6-11. Lubrication Data Automatic Typewriter MX-1115/UG

# AUTOMATIC TYPER MX-1115/UG

REST AUTOMATIC TYPER ON ITS BACK



**CAUTION:** Wipe off excessive lubricant. Do not distort or disturb springs.

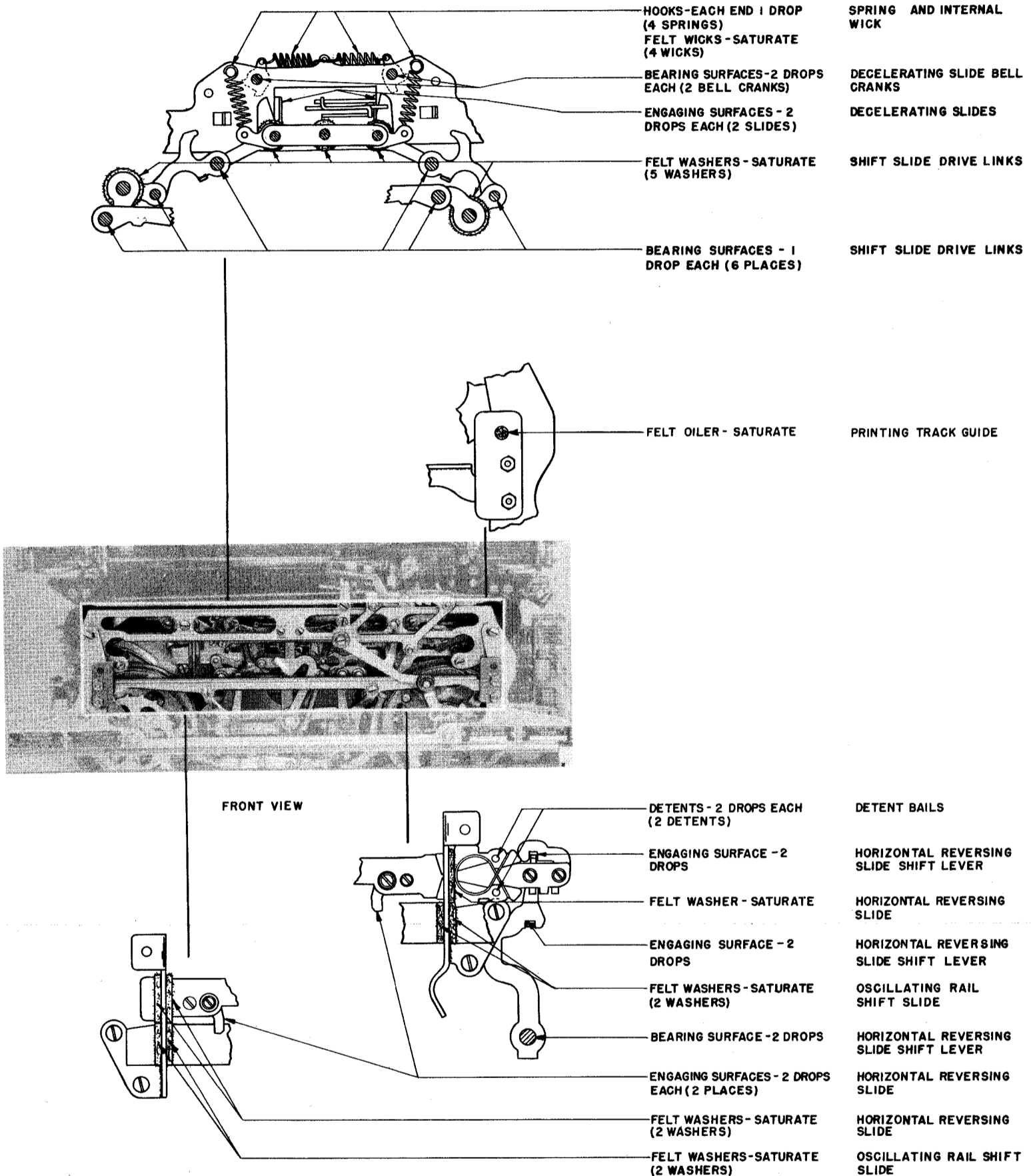
- Notes:**
- Interval—four months at 60-wpm; three months at 75-wpm; two months at 100-wpm.
  - Use type KS-7470 oil as supplied for normal or high temperatures —5° to +55° C. (41° to 131° F.). For lower temperatures, dilute the KS-7470 with kerosene (half and half).

SPECIFICATION	TITLE	STANDARD NAVY STOCK NUMBER									
		1 PT.	1 QT.	1 GAL.	5 GAL.	8 OZS.	1 LB.	5 LB.	25 LB.	35 LB.	100 LB.
Teletype KS-7470	Lubricating oil	N17-T-350011-463	N17-T-350002-878	N17-T-350009-698							
AN-G-25	Lubricating grease					R14-G-984-500	R14-G-982-20	R14-G-984-520	R14-G-984-540	R14-G-984-550	R14-G-984-560
VV-K-211	Kerosene				W7-K-505						

Figure 6-12. Lubrication Data  
Automatic Typewriter MX-1115/UG

**AUTOMATIC TYPWR MX-1115/UG**

REST AUTOMATIC TYPWR ON ITS BACK



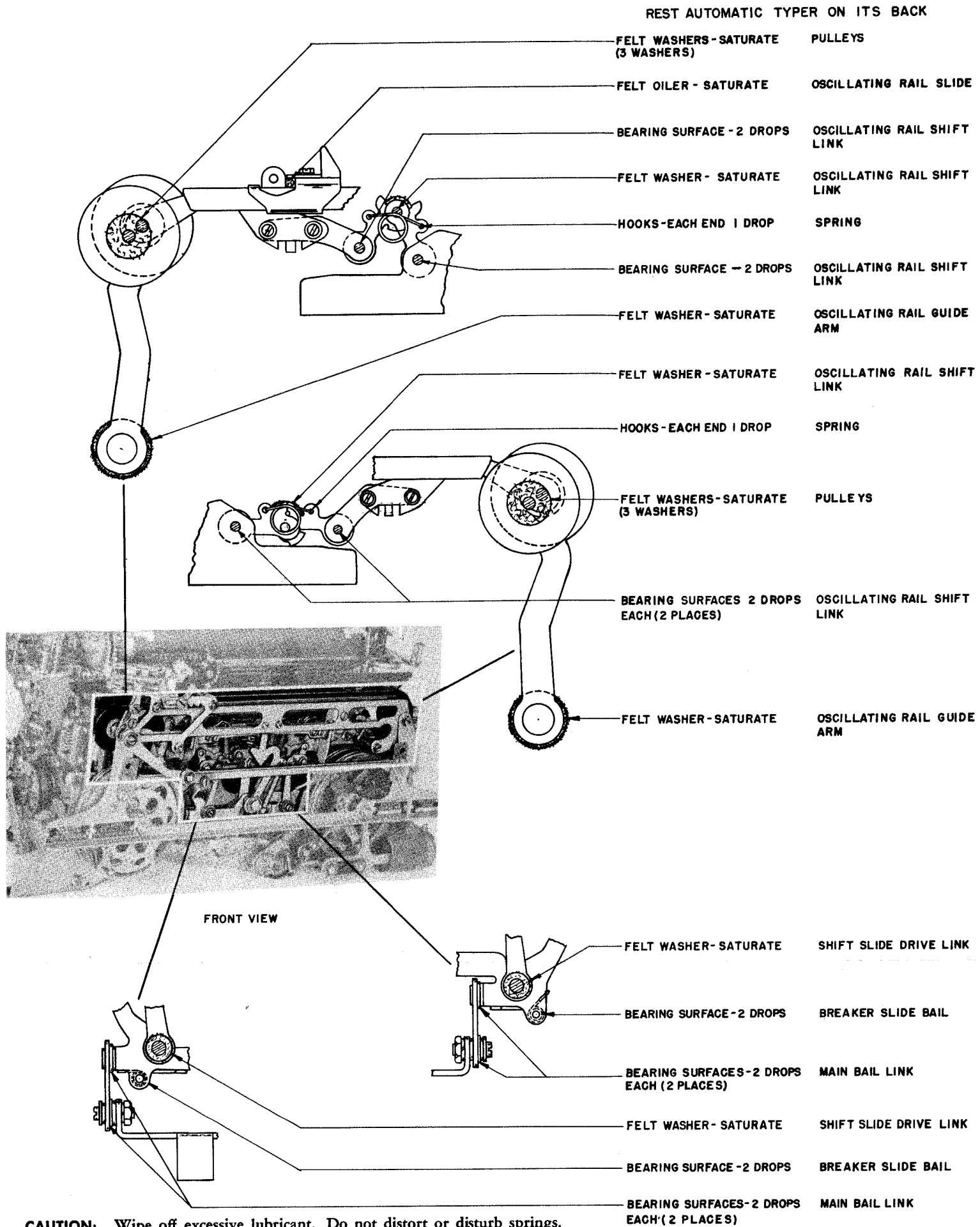
**CAUTION:** Wipe off excessive lubricant. Do not distort or disturb springs.

- Notes:**
- Interval—four months at 60-wpm; three months at 75-wpm; two months at 100-wpm.
  - All lubricant is type KS-7470. Use as supplied for normal or high temperatures  $-5^{\circ}$  to  $+55^{\circ}$  C. ( $41^{\circ}$  to  $131^{\circ}$  F.). For lower temperatures, dilute the KS-7470 oil with kerosene (half and half).

NAVY LUBRICANT		STANDARD NAVY STOCK NUMBER									
SPECIFICATION	TITLE	1 PT.	1 QT.	1 GAL.	5 GAL.	8 OZS.	1 LB.	5 LB.	25 LB.	35 LB.	100 LB.
Teletype KS-7470	Lubricating oil	N17-T-350011-463	N17-T-350002-878	N17-T-350009-698							
AN-G-25	Lubricating grease					R14-G-984-500	R14-G-982-20	R14-G-984-520	R14-G-984-540	R14-G-984-550	R14-G-984-560
VV-K-211	Kerosene				W7-K-505						



# AUTOMATIC TYPER MX-1115/UG



**CAUTION:** Wipe off excessive lubricant. Do not distort or disturb springs.

- Notes:**
1. Interval—four months at 60-wpm; three months at 75-wpm; two months at 100-wpm.
  2. All lubricant is type KS-7470. Use as supplied for normal or high temperatures  $-5^{\circ}$  to  $+55^{\circ}$  C. ( $41^{\circ}$  to  $131^{\circ}$  F.). For lower temperatures, dilute the KS-7470 oil with kerosene (half and half).

NAVY LUBRICANT		STANDARD NAVY STOCK NUMBER									
SPECIFICATION	TITLE	1 PT.	1 QT.	1 GAL.	5 GAL.	8 OZS.	1 LB.	5 LB.	25 LB.	35 LB.	100 LB.
Teletype KS-7470	Lubricating oil	N17-T-350011-463	N17-T-350002-878	N17-T-350009-698							
AN-G-25	Lubricating grease					R14-G-984-500	R14-G-982-20	R14-G-984-520	R14-G-984-540	R14-G-984-550	R14-G-984-560
VV-K-211	Kerosene				W7-K-505						

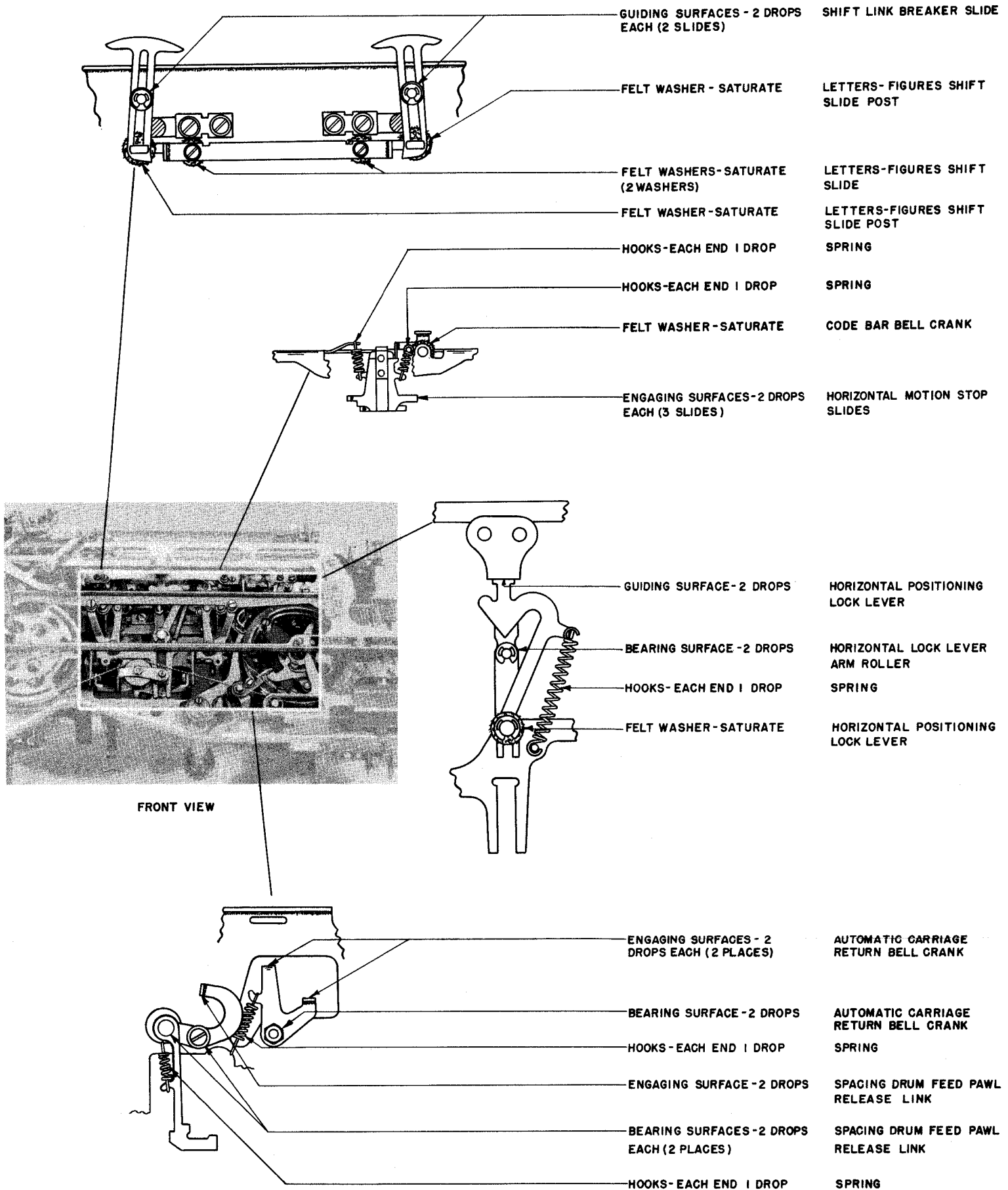
NAVSHIPS 91393  
TT-47/UG, TT-48/UG, TT-69/UG, TT-70/UG

NAVSHIPS 91393  
TT-47/UG, TT-48/UG, TT-69/UG, TT-70/UG

Figure 6-14. Lubrication Data  
Automatic Typewriter MX-1115/UG

### AUTOMATIC TYPER MX-1115/UG

REST AUTOMATIC TYPER ON ITS BACK

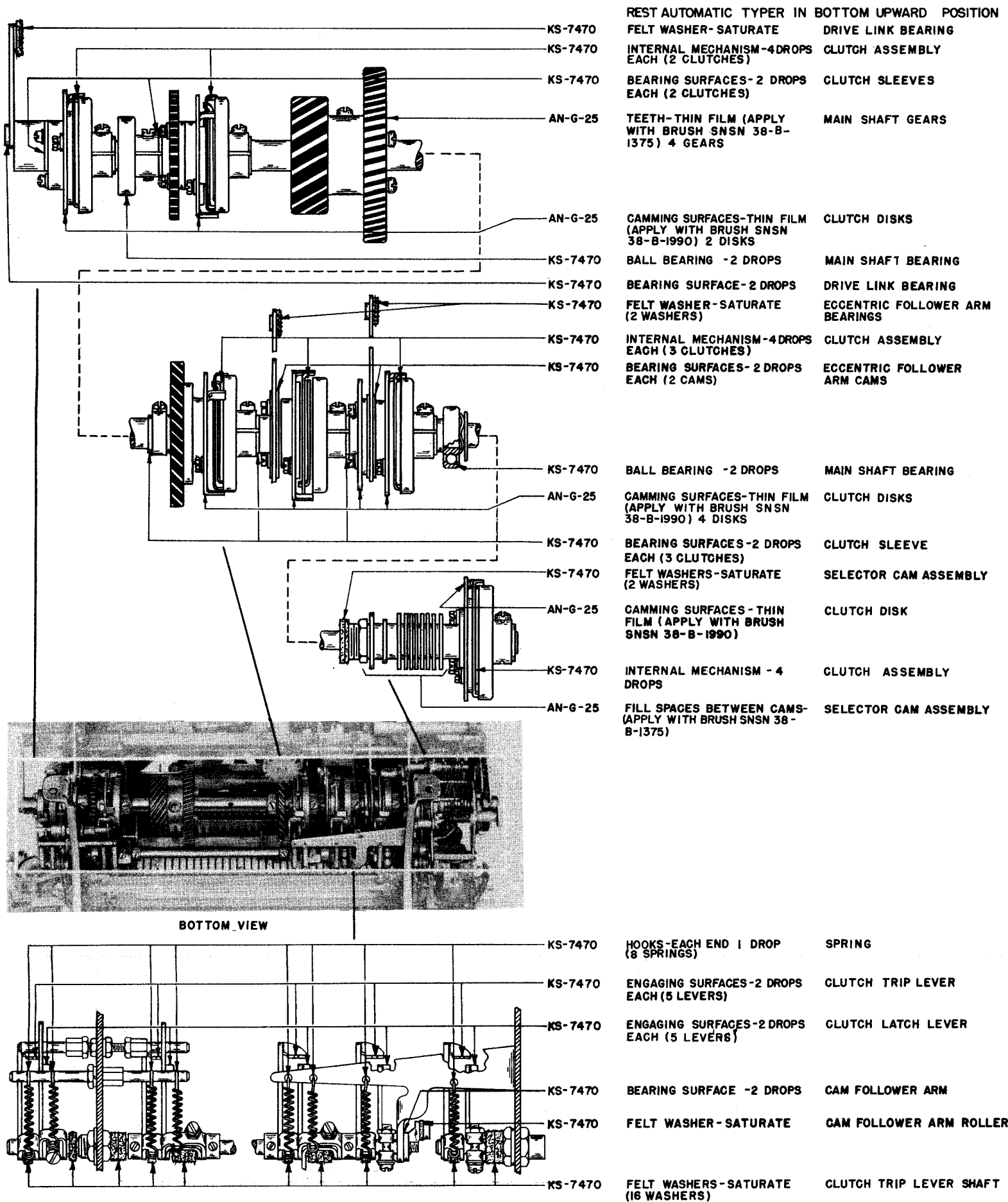


**CAUTION:** Wipe off excessive lubricant. Do not distort or disturb springs.

- Notes:**
- Interval—four months at 60-wpm; three months at 75-wpm; two months at 100-wpm.
  - All lubricant is type KS-7470. Use as supplied for normal or high temperatures  $-5^{\circ}$  to  $+55^{\circ}$  C. ( $41^{\circ}$  to  $131^{\circ}$  F.). For lower temperatures, dilute the KS-7470 oil with kerosene (half and half).

SPECIFICATION	NAVY LUBRICANT TITLE	STANDARD NAVY STOCK NUMBER									
		1 PT.	1 QT.	1 GAL.	5 GAL.	8 OZS.	1 LB.	5 LB.	25 LB.	35 LB.	100 LB.
Teletype KS-7470	Lubricating oil	N17-T-350011-463	N17-T-350002-878	N17-T-350009-698							
AN-G-25	Lubricating grease					R14-G-984-500	R14-G-982-20	R14-G-984-520	R14-G-984-540	R14-G-984-550	R14-G-984-560
VV-K-211	Kerosene				W7-K-505						

### AUTOMATIC TYPER MX-1115/UG



**CAUTION:** Wipe off excessive lubricant. Do not distort or disturb springs.

**Notes:** 1. Interval—four months at 60-wpm; three months at 75-wpm; two months at 100-wpm.  
2. Use type KS-7470 oil as supplied for normal or high temperatures —5° to +55° C. (41° to 131° F.). For lower temperatures, dilute the KS-7470 with kerosene (half and half).

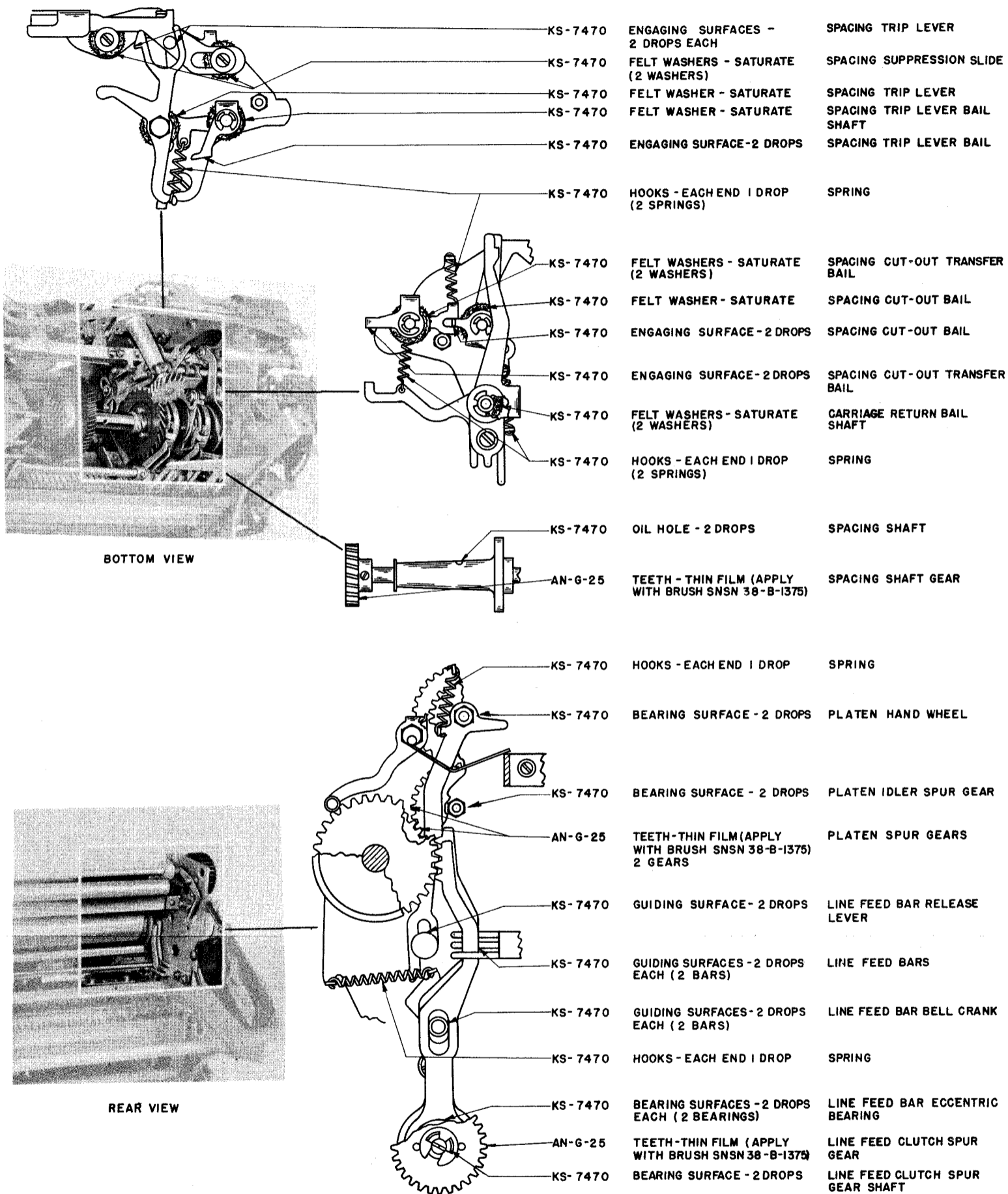
NAVY LUBRICANT		STANDARD NAVY STOCK NUMBER									
SPECIFICATION	TITLE	1 PT.	1 QT.	1 GAL.	5 GAL.	8 OZS.	1 LB.	5 LB.	25 LB.	35 LB.	100 LB.
Teletype KS-7470	Lubricating oil	N17-T-350011-463	N17-T-350002-878	N17-T-350009-698							
AN-G-25	Lubricating grease					R14-G-984-500	R14-G-982-20	R14-G-984-520	R14-G-984-540	R14-G-984-550	R14-G-984-560
VV-K-211	Kerosene				W7-K-505						

Figure 6-16. Lubrication Data

Automatic Typewriter MX-1115/UG

# AUTOMATIC TYPER MX-1115/UG

REST AUTOMATIC TYPER IN BOTTOM UPWARD POSITION



**CAUTION:** Wipe off excessive lubricant. Do not distort or disturb springs.

**Notes:** 1. Interval—four months at 60-wpm; three months at 75-wpm; two months at 100-wpm.  
2. Use type KS-7470 oil as supplied for normal or high temperatures -5° to +55° C. (41° to 131° F.). For lower temperatures, dilute the KS-7470 with kerosene (half and half).

NAVY LUBRICANT		STANDARD NAVY STOCK NUMBER									
SPECIFICATION	TITLE	1 PT.	1 QT.	1 GAL.	5 GAL.	8 OZS.	1 LB.	5 LB.	25 LB.	35 LB.	100 LB.
Teletype KS-7470	Lubricating oil	N17-T-350011-463	N17-T-350002-878	N17-T-350009-698							
AN-G-25	Lubricating grease					R14-G-984-500	R14-G-982-20	R14-G-984-520	R14-G-984-540	R14-G-984-550	R14-G-984-560
VV-K-211	Kerosene				W7-K-505						

Figure 6-17. Lubrication Data Automatic Typewriter MX-1115/UG



### FAILURE REPORT

A failure report must be filled out for the failure of any part of the equipment whether caused by defective or worn parts, improper operation, or external influences. It should be made on Failure Report, form NBS-383, which has been designed to simplify this requirement. The card must be filled out and forwarded to BUSHIPS in the franked envelope which is provided. Full instructions are to be found on each card.

Use great care in filling the card out to make certain it carries adequate information. For example, under "Circuit Symbol" use the proper circuit identification taken from the schematic drawings, such as T-803, in the case of a transformer, or R-207, for a resistor. Do not substitute brevity for clarity. Use the back of the card to completely describe the cause of failure and attach an extra piece of paper if necessary.

The purpose of this report is to inform BUSHIPS of the cause and rate of failures. The information is used by the Bureau in the design of future equipment and in the maintenance of adequate supplies to keep the present equipment going. The cards you send in, together with those from hundreds of other ships, furnish a store of information permitting the Bureau to keep in touch with the performance of the equipment of your ship and all other ships of the Navy.

This report is not a requisition. You must request the replacement of parts through your Officer-in-Charge in the usual manner.

Make certain you have a supply of Failure Report cards and envelopes on board. They may be obtained from any Electronics Officer.

U. S. NAVY  
ELECTRONIC  
FAILURE REPORT  
NAVSHIPS 383 (REV. 4-49)

NOTICE: 1. Read instructions interleaved in this pad prior to preparing report.  
2. Report all failures (Electronic, electrical, and mechanical).  
3. Use separate sheet to report each part failure.

REPORT--SHIPS-84

REPORT NO. \_\_\_\_\_

DATE OF FAILURE \_\_\_\_\_

EQUIPMENT INSTALLED IN (Number and name of ship or station)		REPAIRS MADE BY (Number and name of ship, yard, tender, etc.)		LEAVE BLANK	REPAIRED BY (Name and rate of person)	
SERVICE USING EQUIPMENT (Check one)		TYPE ACTIVITY USING EQUIPMENT (Check one)		EQUIPMENT CATEGORY (Check one)		
1 <input type="checkbox"/> NAVY 2 <input type="checkbox"/> USCG 3 <input type="checkbox"/> USMC		1 <input type="checkbox"/> SHIP 2 <input type="checkbox"/> SHORE 3 <input type="checkbox"/> AMPHIBIOUS		1 <input type="checkbox"/> RADIO 2 <input type="checkbox"/> RADAR 3 <input type="checkbox"/> SONAR 4 <input type="checkbox"/> TEST		
4 <input type="checkbox"/> ARMY 5 <input type="checkbox"/> AIR FORCE		4 <input type="checkbox"/> AIR-BORNE 5 <input type="checkbox"/> OTHER (Specify)		5 <input type="checkbox"/> ORDNANCE 6 <input type="checkbox"/> NANCY AND RADIAC 8 <input type="checkbox"/> POWER 9 <input type="checkbox"/> OTHER (Specify)		
NAME PLATE DATA	MODEL DESIGNATION	SERIAL NO.	NAME OF CONTRACTOR		MAJOR UNIT INVOLVED	TYPE NO. AND NAME
	LEAVE BLANK	CONTRACT NO.	DATE INSTALLED			SERIAL NO.
PART FAILURE DATA (Check one)	COMPLETE TUBE TYPE, OR NAME AND NAVY TYPE NO. OF PART		STANDARD NAVY STOCK NO. (See note 10)	SYMBOL DESIGNATION (V-101, R-201, etc.)		FAILED IN (Check one)
	<input type="checkbox"/> TUBE	<input type="checkbox"/> OTHER	APPROXIMATE LIFE (Hours)	LEAVE BLANK	MANUFACTURER'S NAME	1 <input type="checkbox"/> OPERATION 2 <input type="checkbox"/> FAULTY PACKAGING 3 <input type="checkbox"/> HANDLING 4 <input type="checkbox"/> OTHER (Specify)
		MANUFACTURER'S NAME	SERIAL NO. OF TUBE OR PART	ARMY STOCK NO. (USMC only)	MFRS' DATA (See note 13)	

CHECK TYPE OF FAILURE

002 <input type="checkbox"/> AIRLEAK	130 <input type="checkbox"/> CHANGE OF VALUE	300 <input type="checkbox"/> GROUNDED	360 <input type="checkbox"/> INTERMITTENT OPERATION	225 <input type="checkbox"/> MFR'S DEFECT	003 <input type="checkbox"/> OPEN FILAMENT	540 <input type="checkbox"/> PUNCTURED	620 <input type="checkbox"/> SHORTED TO PRIMARY
007 <input type="checkbox"/> ARCING	170 <input type="checkbox"/> CORRODED	310 <input type="checkbox"/> HANDLING IMPROPER	380 <input type="checkbox"/> LEAKAGE	009 <input type="checkbox"/> MICROPHONIC	460 <input type="checkbox"/> OPEN PRIMARY	011 <input type="checkbox"/> SCREEN DEFECTS	630 <input type="checkbox"/> SHORTED TO SECONDARY
070 <input type="checkbox"/> BROKEN	190 <input type="checkbox"/> CRACKED	320 <input type="checkbox"/> HIGH VOLTAGE BREAK-DOWN	013 <input type="checkbox"/> LOOSE BASE	008 <input type="checkbox"/> NOISY	470 <input type="checkbox"/> OPEN SECONDARY	005 <input type="checkbox"/> SHORTED INTERMITTENT	020 <input type="checkbox"/> UNSTABLE OPERATION
014 <input type="checkbox"/> BROKEN BASE	330 <input type="checkbox"/> EXCESSIVE HUM	340 <input type="checkbox"/> INSTALLED IMPROPERLY	012 <input type="checkbox"/> LOOSE ELEMENTS	022 <input type="checkbox"/> NO OSCILLATION	480 <input type="checkbox"/> OVERHEATED	006 <input type="checkbox"/> SHORTED PERMANENT	<input type="checkbox"/> OTHER (Specify in remarks)
015 <input type="checkbox"/> BROKEN GLASS	001 <input type="checkbox"/> GASSY	350 <input type="checkbox"/> INSULATION BREAK-DOWN	004 <input type="checkbox"/> LOW EMISSION	440 <input type="checkbox"/> OLD AGE (Specify in remarks)	021 <input type="checkbox"/> OVERLOADED	600 <input type="checkbox"/> SHORTED TO CASE	
080 <input type="checkbox"/> BURNED OUT	016 <input type="checkbox"/> GLASS STRAIN		040 <input type="checkbox"/> MECHANICAL BINDING	450 <input type="checkbox"/> OPEN	010 <input type="checkbox"/> POOR FOCUS	610 <input type="checkbox"/> SHORTED TO FRAME	GPO 16-58703-1

REMARKS: INCLUDE CAUSE OF FAILURE AND SUGGESTED CHANGES (Continue remarks on reverse side)

LEAVE BLANK

Failure Report, Sample Form

**SECTION 7  
CORRECTIVE MAINTENANCE**

**1. GENERAL.**

*a.* The information contained in this section is planned so as to provide maintenance personnel with effective means for locating and clearing trouble. It is necessary that the technician be thoroughly familiar with the theory of operation of the equipment and with the adjusting routine before attempting any maintenance procedures.

*b.* The system of assigning symbols to component items deserves mention since it is frequently desirable to identify a component item with a particular unit.

**Component Numbering System**

Unit	Numerical Range
Keyboard MX-1114/UG . . . . .	101-499
AC Motor PD-17/U (synchronous) . .	501-599
AC Motor PD-17A/U (Synchronous)	501-599
AC Motor PD-18/U (governed) . . .	601-699
Cabinets CY-870/UG and CY-871/UG	701-1099
Power Distribution Panel SB-154/UG	1101-1299
Automatic Typewriter MX-1115/UG . . . . .	1301-2158

**2. TROUBLE SHOOTING.**

*a. GENERAL.*—Failures of the equipment can be traced functionally by means of the chart, Table 7-4. By following the appropriate leads as manifested by the behavior of the equipment, a block will be found which will provide index numbers to a group of probable faults tabulated in paragraph 2*b.* An elimination process relative to these probabilities should greatly facilitate the clearing of trouble.

*b. TABULATION OF FAULTS INDICATED IN TROUBLE SHOOTING CHART* Page 7-141.

**(1) MOTOR DOES NOT START.**

*(a)* Power failure—check for 115 volt, 60 cycle applied voltage between terminals 29 and 30 on Cabinet.

*(b)* Fuse failure—check Power Distribution Panel fuses F-1101 and F-1102. If open, rotate the motor by hand and check for excessive load. Refer to Primary Power Distribution Diagram, figure 7-135, and Wiring Diagram, figure 7-137, and check the following items for possible failure.

1. Stop magnet E-1103, line shunt relay K-1101 and signal bell magnet E-756—shorted windings.

2. Motor—shorted windings.

*(c)* Motor control assembly—not functioning

properly. Check requirements in figure 7-90.

*(d)* Open windings—start magnets E-1108A and E-1108B.

*(e)* Motor—brushes not making contact.

*(f)* Governor—contact open, dirty (governed motor only).

**(2) MOTOR DOES NOT STOP.**

*(a)* Time delay switch S-101 not closing—check requirements in figures 7-20, 7-27, and 7-28.

*(b)* Motor control mechanism not functioning properly—check requirements in figure 7-90.

*(c)* Stop magnet E-1103—open windings.

**(3) IRREGULAR MOTOR SPEED.**

*(a)* Incorrect voltage.

*(b)* Governor adjustment—check requirements in figure 7-88.

*(c)* Governor—contacts burnt (governed motor only).

*(d)* Shorted capacitors C-602—check capacitors.

*(e)* Poor brush contact (governed motor only).

**(4) NO SIGNALS FROM KEYBOARD.**

**(a) OPEN SIGNAL LINE.**

1. Contacts dirty—burnish.

2. Contacts incorrectly adjusted—check adjustment figure 7-10.

3. Open electrical noise suppressor Z-101.

4. Flutter lever out of adjustment figure 7-6.

5. Binding mechanism—check freeness of moving parts.

**(b) SIGNAL LINE NOT OPENING.**

1. Shorted contacts.

2. Shorted electrical noise suppressor Z-101.

3. Contact fails to open—check adjustment in figures 7-6 and 7-10.

4. Binding mechanism—check chain of linkage for freeness.

**(5) SHORT ON MARGIN.**

*(a)* Line current—inadequate or excessive.

*(b)* Shorted selector magnet coils E-1304 and E-1305.

*(c)* Incorrect motor speed—see paragraph 2*b.*(3).

## Paragraph 2.b.(5)(d)

TT-47/UG, TT-48/UG, TT-69/UG, TT-70/UG

(d) Armature dirty, or oily—drag thin piece of clean paper between armature and magnet core.

(e) Binds in moving parts of code bar linkage—check for freeness.

(f) Incorrect adjustment—check following:

1. Selector Magnet Bracket, figure 7-33.
2. Selector Armature, figure 7-31.
3. Selector Magnet Core, figure 7-32.
4. Selector Armature Spring, figure 7-31.
5. Stop Arm Yield Spring, figure 7-40.
6. Selector Clutch Operating Bail Spring, figure 7-39.

## (6) INTERMITTENT ERRORS.

(a) Range finder set beyond range limits.

(b) Line current—inadequate or excessive.

(c) Shorted selector magnet coils E-1304 and E-1305.

(d) Incorrect motor speed—see paragraph 2.b.(3).

(e) Armature dirty—drag thin piece of clean paper between armature and magnet core.

(f) Binds in moving parts of selector and code bar linkage—check for freeness.

(g) Incorrect adjustment—check following:

1. Selector Magnet Bracket, figure 7-33.
2. Shift Lever Link Guide, figure 7-38.
3. Code Bar Detent, figure 7-84.
4. Selector Push Lever Spring, figure 7-36.
5. Selector Transfer Lever Spring, figure 7-35.

## (7) GAINING OR LOSING A PULSE.

(a) Binds in moving parts of selector and code bar linkage on particular pulse in trouble—check for freeness.

(b) Incorrect adjustment—check following adjustments on particular pulse in trouble:

1. Selector Magnet Bracket, figure 7-33.
2. Shift Lever Link Guide, figure 7-38.
3. Code Bar Detent, figure 7-84.
4. Push Lever Spring, figure 7-36.
5. Transfer Lever Spring, figure 7-35.
6. Code Bar Detent, figure 7-84.

## (8) GARBLING.

(a) Incorrect line current.

(b) Defective selector coils.

(c) Incorrect motor speed—see paragraph 2.b.(3).

(d) Range finder setting out of range.

(e) Armature dirty—drag thin piece of clean paper between armature and magnet core.

(f) Binds in moving parts of selector and code bar linkage—check following for freeness.

1. Selector Magnet Core, figure 7-32.
2. Selector Magnet Bracket, figure 7-33.
3. Code Bar Detent, figure 7-84.
4. Armature Spring, figure 7-31.
5. Stop Arm Yield Spring, figure 7-40.

## (9) SPACING FAILURE OR MULTIPLE SPACING.

(a) Binds in moving parts of spacing chain of linkage, figures 7-49 and 7-54—check for freeness.

(b) Incorrect adjustment—check following:

1. Spacing Clutch Trip Lever Bail Cam Plate, figure 7-54.
2. Spacing Trip Lever, figure 7-49.
3. Carriage Return Lever, figure 7-63.
4. Spacing Trip Lever Spring, figure 7-54.
5. Spacing Trip Lever Bail Spring, figure 7-54.
6. Spacing Pawl Spring, figure 7-59.
7. Clutch Trip Shaft Set Collar, figure 7-43.
8. Function Stripper Blade Arm, figure 7-77.
9. Function Reset Bail Extension Arm, figure 7-55.
10. Function Bar Spring, figure 7-74.

## (10) FAILURE ON LETTERS—FIGURES SHIFT.

(a) Binds in moving parts of letters-figures shift linkage—check for freeness of selector and code bar linkage, letters and figures function slide (figure 7-73).

(b) Incorrect adjustment—check following:

1. Function Stripper Blade Arm, figure 7-76.
2. Shift Code Bar Operating Slides, figure 7-73.
3. Function Reset Bail Extension Arm, figure 7-55.
4. Function Lever Spring, figure 7-74.
5. Function Pawl Spring, figure 7-74.
6. Function Bar Spring, figure 7-74.

## (11) FAILURE ON CARRIAGE RETURN.

(a) Binds in moving parts of linkage for carriage return function. Check for freeness of selector and code bar linkage, function bar reset bail and function bar linkage in function box and carriage return bail and slide.

(b) Incorrect adjustment—check following:

1. Function Reset Bail Extension Arm, figure 7-55.
2. Function Lever, Function Pawl, and Function Bar Springs, figure 7-74.

## (12) FAILURE ON LINE FEED.

(a) Binds in moving parts of linkage for line



feed function—check for freeness of selector and code bar linkage, function bar reset bail and function bar linkage in function box, line feed function slide arm and line feed clutch trip lever, figure 7-45, line feed bars, figure 7-50, line feed stripper and stripper bail, figure 7-78—check position of single-double line feed lever.

- (b) Incorrect adjustments—check following:
1. Line Feed Clutch Trip Lever Eccentric Post, figure 7-45.
  2. Line Feed Clutch Trip Lever Adjusting Screw, figure 7-45.
  3. Function Stripper Blade Arms, figure 7-77.
  4. Line Feed Clutch Trip Lever Spring, figure 7-44.
  5. Function Reset Bail Extension Arm, figure 7-55.
  6. Function Bar Spring, figure 7-74.
  7. Function Pawl Spring, figure 7-74.
  8. Function Lever Spring, figure 7-74.

**(13) FAILURE ON SIGNAL BELL.**

- (a) Electrical contacts on function box—dirty or burnt.
- (b) Open magnet E-756 in signal bell.
- (c) Low voltage.
- (d) Bell armature dirty.
- (e) Binds in moving parts of linkage for signal bell function—check for freeness of selector and code bar linkage, function bar reset bail, function bar linkage in function box, and armature in signal bell assembly.
- (f) Incorrect adjustment—check following:
1. Function Reset Bail Extension Arm, figure 7-55.
  2. Bell contact, figure 7-82.
  3. Remote Signal Bell, figure 7-91.
  4. Remote Signal Bell Armature Spring, figure 7-91.
  5. Function Bar Spring, figure 7-74.
  6. Function Pawl Spring, figure 7-74.
  7. Function Lever Spring, figure 7-74.

**(14) RIBBON FAILS TO FEED OR REVERSE.**

- (a) Binds in moving parts of ribbon feeding or reversing mechanism—check for freeness of ribbon feed levers, ribbon lever, ribbon reversing lever, ribbon reverse detent lever.
- (b) Detent cam loose—check set screws and adjustment, figure 7-71.
- (c) Eyelet missing from ribbon.
- (d) Incorrect adjustment—check following:
1. Ribbon Unit Feed Lever Bail Bracket, figure 7-72.

2. Ribbon Reverse Spur Gear, figure 7-71.
3. Ribbon Reverse Detent, figure 7-71.
4. Ribbon Feed Lever Spring, figure 7-72.
5. Ribbon Ratchet Wheel Friction, figure 7-72.
6. Ribbon Lever, figure 7-72.
7. Ribbon Reverse Detent Lever Spring, figure 7-71.

**(15) FAILURE TO POSITION.**

(a) Binds in moving parts of linkage for type bar positioning mechanism—check freeness of main rocker shaft; vertical positioning linkage, figures 7-52 and 7-53; SUP., 1, 2, 3, and COM code bars; reversing slide, figure 7-56, shift slide drive linkage and oscillator rail linkage, figure 7-56.

(b) Incorrect adjustment—check following:

1. Rocker Shaft Left Bracket, figure 7-50.
2. Vertical Positioning Lever Eccentric Stud, figures 7-52 and 7-53.
3. Shift Slide Drive Linkage, figure 7-57.
4. Vertical Positioning Lever Spring, figure 7-52.
5. Shift Linkage Spring, figure 7-68.
6. Vertical Positioning Lock Lever Spring, figure 7-53.

**(16) FAILURE TO PRINT.**

(a) Binds in printing carriage assembly—check for freeness in moving parts, and for missing springs.

(b) Ribbon not properly installed.

(c) Incorrect adjustments—check following:

1. Printing Track, figure 7-69.
2. Printing Arm, figure 7-70.
3. Printing Hammer Plunger Spring, figure 7-69.

**3. REMOVAL AND REPAIR.**

**Note**

If a part that is mounted on shims is to be removed, the number of shims used at each of its mounting screws should be noted so that the same shim pile-up can be replaced when the part is remounted.

**a. AUTOMATIC TYPER.**

**(1) TYPE BOX. (See figure 7-126.)**

- (a) To remove the type box, proceed as follows:
1. Trip the O-1845 type box latch toggle (figure 7-126) to the right.
  2. Lift the right end of the type box upward to an angle of approximately 45° and pull the type box toward the right to disengage it from the left hand bearing stud.

3. The disassembly of the type box is shown in figure 7-126.

4. To reinstall the type box, reverse the procedure used in removing it. The type box should be firmly seated on the bearing studs and the point of the latch toggle should be placed in the notch of the type box plate before moving the toggle to its latched position.

(2) PRINTING CARRIAGE (See figure 7-113.)

(a) To remove the printing carriage, proceed as follows:

1. Loosen the two H-1309 screws (figure 7-113) which clamp the O-1313 plate to the wire rope and disengage the carriage from the wire rope.

2. Move the carriage to the left end of its track and tilt the lower part forward to disengage the rollers from the track.

3. The disassembly of the printing carriage is shown in figure 7-113.

4. To reinstall the carriage, reverse the procedure used in removing it. Make certain that the O-1324 printing arm is correctly re-engaged with the O-1531 printing track.

5. Position the carriage clamp on the wire rope for correct printing position as specified in figure 7-67.

(3) TYPE BOX CARRIAGE. (See figure 7-126.)

(a) To remove the type box carriage, proceed as follows:

1. Move the type box carriage to its extreme right hand position.

2. Hold the O-1471 to O-1476 code bar shift bars in the marking position and rotate the main shaft so that the type box is in its uppermost position.

3. Remove the H-1848 retainer ring from the stud in the right hand end of the O-1844 type box carriage link and disengage the link from the carriage.

4. Hold the O-1852 ribbon guide forward and the O-1395 ribbon reverse lever back and pull the carriage toward the right to disengage it from the carriage track.

5. The disassembly of the type box carriage is shown in figure 7-126.

6. To reinstall the carriage, reverse the procedure used in removing it. See figure 7-65 for adjustment.

(4) FRONT PLATE. (See figures 7-120, 7-121 and 7-122.)

(a) To remove the front plate, proceed as follows:

1. Remove the Automatic Typewriter from the Keyboard.

2. Remove the H-1848 retainer ring from the

O-1844 type box carriage link right hand stud and disengage the link from the carriage.

(See instructions for removing the link retainer in paragraph 3.a.(3).)

3. Remove the two H-2007 screws, figure 7-129, which secure the O-1530 main bail drive bracket (figure 7-120) to the O-2017 rocker shaft.

4. Remove the O-1613 spacing shaft gear.

5. Remove the four H-1601 screws which secure the front plate assembly to the typer side frames.

6. Pull the front plate assembly forward to disengage it from its connecting parts in the typer.

7. The disassembly of the front plate is shown in figures 7-120 to 7-122.

8. To reinstall the front plate assembly, reverse the procedure used in removing it. Make certain that the O-1617 and O-1619 code bar bell cranks (figure 7-121), the O-1580 letters-figures shift slide, the O-1615 reversing slide shift lever (figure 7-121), the O-1585 automatic C.R.-L.F. bell crank, and the O-2046 carriage return lever extension are properly engaged with their mating parts before tightening the front plate mounting screws. Replace the O-1613 spacing shaft gear. See figure 7-49 for adjustment on phasing the spacing gears.

(5) FUNCTION BOX. (See figure 7-117.)

(a) To remove the function box, proceed as follows:

1. Remove the Automatic Typewriter from the Keyboard.

2. Remove the O-1960 rear tie bar from the Automatic Typewriter side frames.

3. Remove the O-2044 line feed function pawl stripper from the O-2016 stripper blade.

4. Remove the O-2096 single-double line feed lever bearing screw and disengage the lever from the notch in the stripper blade.

5. Hold the stripper blade toward the right side of the Automatic Typewriter and unhook the O-2008 stripper blade left hand arm from the blade.

6. Pull the stripper blade toward the left side of the Automatic Typewriter to disengage the stripper blade from the O-1926 right hand arm and remove the stripper blade from the Automatic Typewriter.

7. Remove the H-1416 and H-1433 screws which secure the function box assembly in the Automatic Typewriter (figure 7-117).

8. Remove the H-1427 contact pileup mounting screws and the H-1399 cable clamp mounting screw from the top of the function box. Lay contact pileup and cable clamp aside.

9. Lift the function box assembly upward to disengage it from its locating brackets and pull toward

the rear to disengage the O-1425 letters-figures code bar fork from the code bars.

10. Disassembly of the function box is shown in figure 7-117.

11. When reinstalling the function box assembly, push it forward in its guide rails to within  $\frac{1}{8}$  inch of its final position, then manually disengage the function pawls from their function levers and push the function box assembly forward and downward until it is latched in place on its locating brackets.

12. Replace the function box mounting screws, cable clamp, and contact pileup.

**(6) FUNCTION BAR. (See figure 7-117.)**

(a) To remove a function bar, proceed as follows:

1. Remove the function box from the Automatic Typer.—See paragraph 3.a.(5).

2. Unhook the O-1405 function bar spring.

3. Hold the function bar toward the rear of the function box and disengage its function pawl from the function bar.

4. Pull the function bar toward the front to remove it from the function box.

5. Disassembly of the function box is shown in figure 7-117.

6. To replace the function bar, reverse the procedure used in removing it.

**(7) CODE BARS. (See figure 7-114.)**

(a) To remove the code bar assembly, proceed as follows:

1. Remove the Automatic Typer from the Keyboard.

2. Remove the function box assembly. See paragraph 3.a.(5).

3. Remove the front plate assembly. See paragraph 3.a.(4).

4. Remove the H-1330, H-1331 and H-1350, H-1351 screws (figure 7-114) which secure the code bar assembly to the side frame.

5. Remove the O-1328 code bar shift bar retainer plate from the A-1303 right hand code bar casting.

6. Remove the O-1471 to O-1476 code bar shift bars from the code bars and pull the code bar assembly forward and to the left.

7. Disassembly of the code bars is shown in figure 7-114.

8. To reinstall the code bar assembly, reverse the procedure used in removing it, except do not tighten the mounting screws. Loosen the H-1333 and H-1337 code bar assembly tie bar screws and hold the code bar casting back and downward firmly against their locating

surfaces on the side frame and tighten the four mounting screws. Tighten the two tie bar screws.

**(8) MAIN SHAFT. (See figure 7-125.)**

(a) To remove the main shaft, proceed as follows:

1. Remove the Automatic Typer from the Keyboard.

2. Remove the selector cam-clutch assembly. See paragraph 3.a.(11).

3. Set the Automatic Typer upside down.

4. Return the carriage to its left hand position.

5. Remove the H-1585 screw (figure 7-121) which secures the O-1612 spacing shaft in the O-1604 spacing pawl hub.

6. Remove the spacing shaft with gear.

7. Remove the O-1757 main shaft right hand bearing retainer plate, figure 7-125.

8. Remove the H-1835 main rocker shaft drive link retainer ring at the H-1832 rocker shaft bracket stud, and the O-1841 retainer plate at the O-1840 clutch bearing and remove the O-1842 link.

9. Remove the two H-1818 screws from the H-1838 main shaft left hand bearing clamp.

10. Unhook the O-1739, O-1736, O-1731, O-1726, O-1707, O-1714, O-1718, O-1744, O-1698 and O-1704 springs from the trip levers and latch levers associated with all clutches. Position the code bar clutch so that the low part of the clutch cam clears the spring arm on the cam follower.

11. Move the main shaft assembly toward the left to disengage the code bar clutch and function clutch links from their connecting pins.

12. Lift the left end of the shaft assembly out of the side frame and position the shaft so that the function clutch link passes the suppression assembly bracket and remove the shaft assembly from the Automatic Typer.

13. When assembling the clutches which have cams and disks marked "O" for identification, the marked side of the parts should face away from the clutch side of the assembly. The function and code bar clutches should have their driving links assembled so that the larger end of the hub faces away from the clutch side of the assembly.

14. Disassembly of the main shaft and clutches is shown in figure 7-125.

15. To reinstall the shaft assembly, reverse the procedure used in removing it.

16. To phase the spacing gears and the line feed gears, see figures 7-49 and 7-50 respectively.

**(9) UPPER DRAW WIRE ROPE. (See figure 7-123.)**

(a) To remove the upper draw wire rope, proceed as follows:

1. Return the carriage to the left position.

2. Loosen the H-1689 nut on the front end of the H-1701 spring drum bearing post, figure 7-122. Operate the O-1629 ratchet escapement lever to unwind the O-1683 carriage return spring.

3. Remove the W-1303 wire rope from the O-1313 clamp plate on the printing carriage, and the O-1672 clamp on the O-1680 oscillating rail slide.

4. Loosen the H-1694 clamp screw which secures the wire rope to the C-1687 spring drum, and remove the wire rope from the drum.

5. Remove the H-1713 screw in the spacing drum which secures the ends of the wire rope, and remove the rope from the drum.

6. Disassembly of the wire rope, spring drum and spacing drum is shown in figure 7-123.

7. To replace the upper draw wire rope, reverse the procedure used in removing it.

(b) LOWER DRAW WIRE ROPE. (See figure 7-123.)

1. Remove the H-1716 screw which secures the W-1304 lower draw wire rope to the O-1693 spacing drum, and remove the end of the rope from the drum.

2. Loosen the H-1691 screws which secure the O-1682 margin indicator cam disk on the spring drum and position the disk to expose the wire rope mounting screw.

3. Remove the H-1696 lower draw wire rope screw and remove the rope from the spring drum.

4. Loosen the H-1625 and H-1641 screws in the H-1673 and H-1674 bearing studs which mount O-1630 and O-1637 printing carriage pulleys and move the studs toward the center of the Automatic Typewriter.

5. Disassembly of the lower draw wire rope is shown in figure 7-123.

6. To replace the wire rope, reverse the procedure used in removing it. Make certain that each rope is in its correct track around the drums.

7. Adjust the position of the type box, the printing carriage, and the wire rope tension as specified in the figures 7-65, 7-67 and 7-60.

(10) PLATEN. (See figure 7-128.)

(a) To remove the platen, proceed as follows:

1. Remove the O-1980 line feed spur gear.

2. Remove the O-1974 and O-1984 platen bearing retainers.

3. Remove the O-2065 paper finger shaft.

4. Hold off the O-2085 detent and lift the platen out of the side frame.

5. Disassembly of the platen is shown in figure 7-128.

6. To replace the platen, reverse the procedure used in removing it. When replacing each platen bearing retainer, put its upper screw in first. Leave the screw slightly loose. Press the lower end of the retainer downward and hook it into the elongated hole in the side frame. Replace the lower screw. Tighten both screws.

(11) SELECTOR CAM-CLUTCH. (See figures 7-119 and 7-125.)

(a) To remove the selector cam-clutch, proceed as follows:

1. Strip the O-1521 to O-1525 push levers from the O-1505 to O-1509 selector levers by raising the O-1526 reset bail and move the O-1503 marking lock lever to the left (end view) until the A-1322 lock lever guide is positioned between the two holes in the lock lever. Insert a 0.040 round wire gauge in the left hand hole to hold the lock lever in this position.

2. Remove the H-1820 screw which mounts the O-1830 selector clutch drum and position the selector clutch so that the stop lug on the O-1839 disk is in the uppermost position.

3. Unhook the O-1488 clutch latch lever spring from the latch lever and position the range scale indicator to 60 or higher.

4. Hold the O-1492 selector cam-clutch operating bail and the O-1500 spacing lock lever away from their cams with the thumb and forefinger of the left hand and withdraw the cam assembly by pulling forward while rocking it back and forth slightly.

5. Disassembly of the selector cam-clutch is shown in figure 7-125. To replace the cam assembly, reverse the procedure used in removing it except for the following:

With the clutch stop lug in the uppermost position, slide the cam assembly over the shaft only to the point where the shaft enters the hole in the clutch drum. It may be necessary to shift the position of the drum on the clutch so that the hole in the hub lines up with the hole in the cam assembly.

While holding the selector cam-clutch operating bail and spacing lock lever away from the cam assembly, use the forefinger of the right hand to lift the code bar clutch trip shaft operating lever away from the cam assembly and, with the thumb of the right hand, push the cam assembly to the installed position (shaft protruding through hub about  $\frac{1}{32}$  inch).

Remove the wire gauge from the hole in the marking lock lever, replace the spring on the clutch latch lever, and restore the range scale to its former setting.

(12) SELECTOR MECHANISM. (See figures 7-119 and 7-125.)

(a) To remove the selector mechanism, proceed as follows:

1. In order to remove the selector mechanism from the Automatic Typewriter the selector cam assembly must be removed. (See paragraph 3.a.(11).)

2. Remove the O-2118 link which ties the selector mechanism to the O-2114 bracket on the code bar positioning mechanism.

3. Remove from the selector mechanism the O-2121 spring which connects with the O-2125 common transfer lever code on the code bar positioning mechanism.

4. Remove the remaining three H-1493 selector mounting screws and lift the selector from the main shaft bearing housing.

5. Disassembly of the selector mechanism is shown in figure 7-119.

6. To replace the selector mechanism, reverse the procedure used in removing it.

7. For readjustment of the selector mechanism see the adjusting figures 7-31 to 7-33 and 7-39 to 7-40.

(13) CODE BAR POSITIONING MECHANISM.  
(See figure 7-114.)

(a) To remove the code bar positioning mechanism, proceed as follows:

1. Remove from the selector the O-2121 spring attached to the common transfer lever and restore any operating push levers to the spacing position by raising the O-1526 reset bail.

2. Loosen the O-2127 clamp screw on the O-2106 shift lever drive arm, and remove the two screws which mount the mechanism—the H-2143 to the side frame, and the H-2145, to the O-2118 selector link.

3. Manipulate the O-2123 to O-2128 transfer levers and O-1471 to O-1476 code bar shift bars while gently twisting the mechanism so as to slide the mechanism off the code bar shift bars.

4. Disassembly of the code bar positioning mechanism is shown in figure 7-114.

5. To replace the mechanism on the Automatic Typewriter, reverse the procedure used in removing it, except for the following: With the main shaft in the stop position, push the code bar shift bars to the marking position (left, front view). Manipulate the code bar shift bars and transfer levers so that the shift bars line up with their respective slots in the O-2104 bracket, and slide the shift bars through the slots, one at a time (leave the bottom slot vacant).

(14) SELECTOR MAGNET ASSEMBLY. (See figure 7-118.)

(a) To remove the selector magnet assembly proceed as follows:

1. Remove the cable from the E-1304 and E-1305 selector magnets. Strip the O-1521 push bars from the selector levers by raising the O-1526 reset bail, hold all of the O-1505 selector levers in the marking position, and move the O-1503 marking lock lever to the left (right end view) until the A-1322 lock lever guide is positioned between the two holes in the lock lever. Insert a 0.040 round wire gauge in the left hand hole to hold the lever in this position.

2. Remove the two H-1443 screws which mount the magnet assembly to the plate and remove the assembly.

3. Disassembly of the selector magnet assembly is shown in figure 7-118.

b. KEYBOARD.

(1) SIGNAL GENERATOR. (See figure 7-102.)

(a) To remove the signal generator from the Keyboard, proceed as follows:

1. Remove the two screws, H-378 and H-381, located to the right and left of the box, and raise the E-103 contact box. (Do not unsolder connections.)

2. Remove the four H-268 mounting screws which mount the signal generator casting, two at the front end of the casting, and two at the rear.

3. Lift the signal generator upward from the Keyboard.

4. Disassembly of the signal generator is shown in figures 7-102 through 7-105.

5. To replace the signal generator, reverse the procedure used in removing it.

(2) KEYBOARD SELECTOR CAM ASSEMBLY.  
(See figure 7-103.)

(a) To remove cam assembly from signal generator, proceed as follows:

1. Remove signal generator from Keyboard. (See paragraph 3.b.(1) above.)

2. Disconnect the O-241 clutch throwout pawl spring and the O-240 throwout bail spring.

3. Disconnect the O-235 clutch stop lever spring.

4. Disconnect the O-282 flutter cam spring.

5. Remove the H-312 front nut of the O-274 stationary shaft.

6. Remove the two screws, H-306 and H-307, that hold the O-272 rear plate to casting.

7. Remove shaft assembly by picking it upward at rear and pulling simultaneously.

8. Disassembly of the cam assembly is shown in figure 7-103.

9. To replace the Keyboard selector cam assembly, reverse the procedure used in removing it.

(3) KEYBOARD LABEL. (See figure 7-101.)

(a) To remove the labels, proceed as follows:

1. Remove the H-231 plastic cover mounting screw and remove the plastic cover.
2. Pick up plastic cover at top edge first.
3. See figure 7-101 for disassembly.
4. To replace the Keyboard label, reverse the procedure used in removing it.

(4) KEY LEVER COVER. (See figure 7-101.)

(a) To remove cover, proceed as follows:

1. Remove the H-230 label covers and labels. (See paragraph 3.b.(3).)
2. Remove the four H-229 screws under the labels, two on extreme right side and two on extreme left side.
3. Pull key lever cover forward to remove.
4. See figure 7-101 for disassembly.
5. To replace the key lever cover, reverse the procedure used in removing it.

(5) KEY LEVER. (See figure 7-96.)

(a) To remove key lever, proceed as follows:

1. Grip any plastic keytop firmly and pull upward. Plastic keytop should not be removed from key lever to change character.
2. See figure 7-96 for disassembly.
3. To replace the key lever, reverse the procedure used in removing it.

(6) SPACE BAR. (See figure 7-101.)

(a) To remove space bar, proceed as follows:

1. Remove the key lever cover. (See paragraph 3.b.(4).)
2. Remove the two H-228 pivot shoulder screws on left and right sides of the O-224 space bar assembly.
3. See figure 7-101 for disassembly of the space bar.
4. To replace the space bar, reverse the procedure used in removing it.

(7) KEY LEVER GUIDE PLATE. (See figure 7-101.)

(a) To remove key lever guide plate, proceed as follows:

1. Remove the key lever cover. (See paragraph 3.b.(4).)
2. Remove the six H-229 mounting screws on top side of guide plate.
3. See figure 7-101 for disassembly.
4. To replace the key lever guide plate, reverse the procedure used in removing it.

(8) KEYBOARD BALL LOCK TRACK. (See figure 7-101.)

(a) To remove ball lock track, proceed as follows:

1. Remove the key lever cover. (See paragraph 3.b.(4).)
2. Remove the two H-248 track mounting screws at left and right ends.
3. Pull track forward with caution to avoid dropping the wedges that are located on the code levers. Wedges must be replaced separately when reassembling.
4. See figure 7-101 for disassembly.
5. To replace the keyboard ball lock track, reverse the procedure used in removing it.

(9) KEYBOARD SEALING PLATE. (See figure 7-101.)

(a) To remove sealing plate, proceed as follows:

1. Remove the key lever cover. See paragraph 3.b.(4).
2. Remove the key levers. See paragraph 3.b.(5).
3. Disconnect the O-234 space bar link at its snap connection.
4. Remove ten mounting screws, two H-253 and two H-251, at extreme right and left sides and two H-253 at bottom edge of the sealing plate.
5. See figure 7-101 for disassembly.
6. To replace the keyboard sealing plate, reverse the procedure used in removing it.

(10) KEYBOARD CODE BAR ASSEMBLY. (See figure 7-96.)

(a) To remove code bar assembly, proceed as follows:

1. Remove the key lever cover. See paragraph 3.b.(4).
2. Remove the key lever. See paragraph 3.b.(5).
3. Disconnect the O-234 space bar link at its snap connection.
4. Remove the signal generator. See paragraph 3.b.(1).
5. Remove the four H-173 code bar assembly mounting screws located on top of base.
6. Remove the two H-197 mounting screws and remove the A-108 manual C.R. bracket.
7. Remove the two H-216 mounting screws and remove the A-111 manual L.F. bracket.
8. Remove the H-220 shoulder screw from the O-219 manual L.F. trip link.
9. Remove the two H-211 screws in the A-109 mounting bracket and the two H-202 screws in the

O-212 plunger guide and remove the keyboard lock mechanism.

10. Remove the H-166 screw and the O-131 code lever bail latch lever with spring. Remove the two H-162 screws and two H-164 screws which mount the O-129 non-repeat bell crank plate assembly. Remove the plate assembly. Remove code bar assembly through the opening in top side of the base.

11. The disassembly of the keyboard code bar assembly is shown in figure 7-96.

12. To replace the keyboard code bar assembly, reverse the procedure used in removing it.

(11) CODE BAR. (See figure 7-96.)

(a) To remove a code bar from the keyboard code bar assembly, proceed as follows:

1. Remove code bar assembly. See paragraph 3.b.(10).

2. Disconnect the O-147 code bar springs.

3. Remove the O-192 latch from the O-141 lock function bar.

4. Loosen the H-177 mounting screws for the left and right code bar guides friction tight and lift the O-142 and O-303 guides to their extreme upward position.

5. Remove code bar by sliding a guide to the left or right to get one end of the code bar out of its guide.

6. Disassembly of the code bar mechanism is shown in figure 7-96.

7. To replace a code bar, reverse the procedure used in removing it.

(12) MOTOR.

(a) SYNCHRONOUS.

1. Disassembly of the Synchronous Motor is shown in figure 7-106.

(b) GOVERNED.

1. Disassembly of the Governed Motor is shown in figure 7-107.

2. In order to prolong the life of governor slip ring brushes, the slip rings are machined to close concentricity requirements after assembly. These slip rings should not be replaced unless facilities for machining operation are available.

3. After the governor parts are assembled, the governor is carefully balanced to reduce vibration; therefore, when it becomes necessary to replace contacts, only the parts being replaced should be moved.

#### 4. ADJUSTMENTS.

a. GENERAL.—The adjustments of each unit are arranged in a sequence that would be followed if a complete readjustment of the unit were undertaken. Tools required to perform the adjustments are listed in table 7-2. After an adjustment has been completed, be sure to tighten any nuts or screws that may have been loosened. The adjusting illustrations, in addition to indicating the adjusting tolerances, positions of moving parts, and spring tensions, also show the angles at which the scale should be applied when measuring spring tensions.

#### Note

When rotating the main shaft of the automatic typer by hand, the clutches do not fully disengage upon reaching their stop positions. In order to relieve the drag on the clutches and permit the main shaft to rotate freely, apply pressure on the lug of each clutch disk (figure 7-41) with a screwdriver to cause it to engage its latch lever. This procedure should always be followed prior to placing the Typer on the Keyboard and switching on the power.

b. MANUAL SELECTION OF CHARACTERS OR FUNCTIONS.—To manually operate the Automatic Typer while removed from the Keyboard, hold the selector magnet armature (figure 7-40) operated and rotate the main shaft in a counterclockwise direction (by means of the handwheel listed in table 7-2) to bring all clutches to their stop positions. Fully disengage all clutches as described in the preceding note. Release the armature momentarily to permit the selector clutch to engage. Turn the main shaft slowly and observe the actions of the marking and spacing lock levers (figure 7-33). While turning the main shaft, move the armature in coordination with the locking levers so as to lock the armature in the attracted position for each MARKING element of the code and in the released position for each SPACING element. It should be noted that the selector levers (figure 7-35) move in succession starting with the inner lever (number one). As soon as the armature is unlocked on the fifth interval, hold it in the attracted position to simulate the affect of the stop impulse and to bring the selector mechanism and associated parts to their stop positions. Continue to rotate the main shaft until all operations initiated by selector action clear through the unit.

c. KEYBOARD MX-1114/UG.

NOTE

IN ORDER TO PERFORM ALL SIGNAL GENERATOR ADJUSTMENTS, IT WILL BE NECESSARY TO REMOVE THE GENERATOR FROM THE KEYBOARD. TO REMOVE, PROCEED AS FOLLOWS: REMOVE THE TWO MOUNTING SCREWS FROM THE CONTACT BOX ADJUSTING BRACKET (FIGURE 7-10) AND DETACH THE BRACKET. ROTATE THE GENERATOR SHAFT TO ITS STOP POSITION; REMOVE THE FOUR MOUNTING SCREWS AND REMOVE THE GENERATOR CAREFULLY.

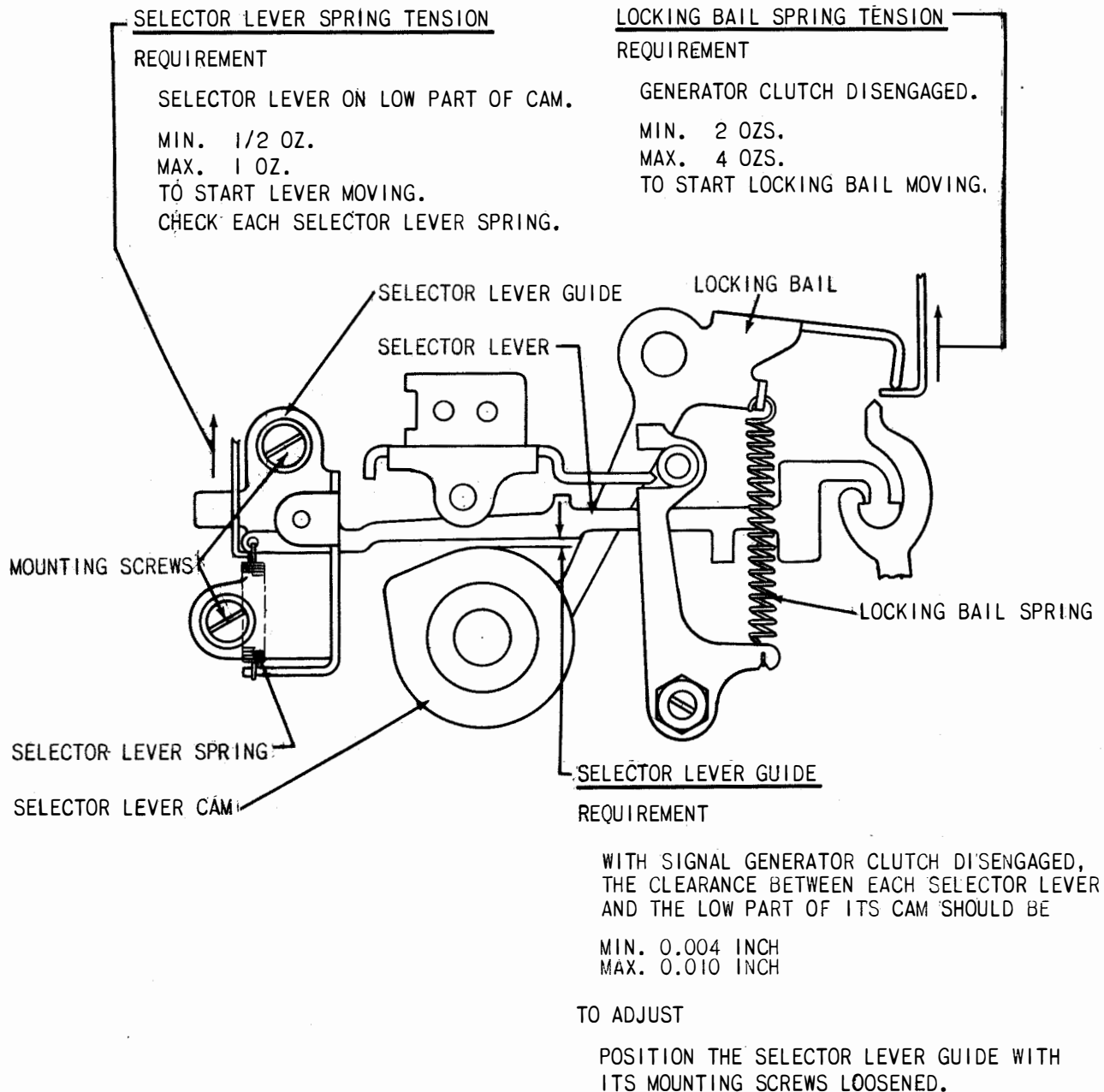
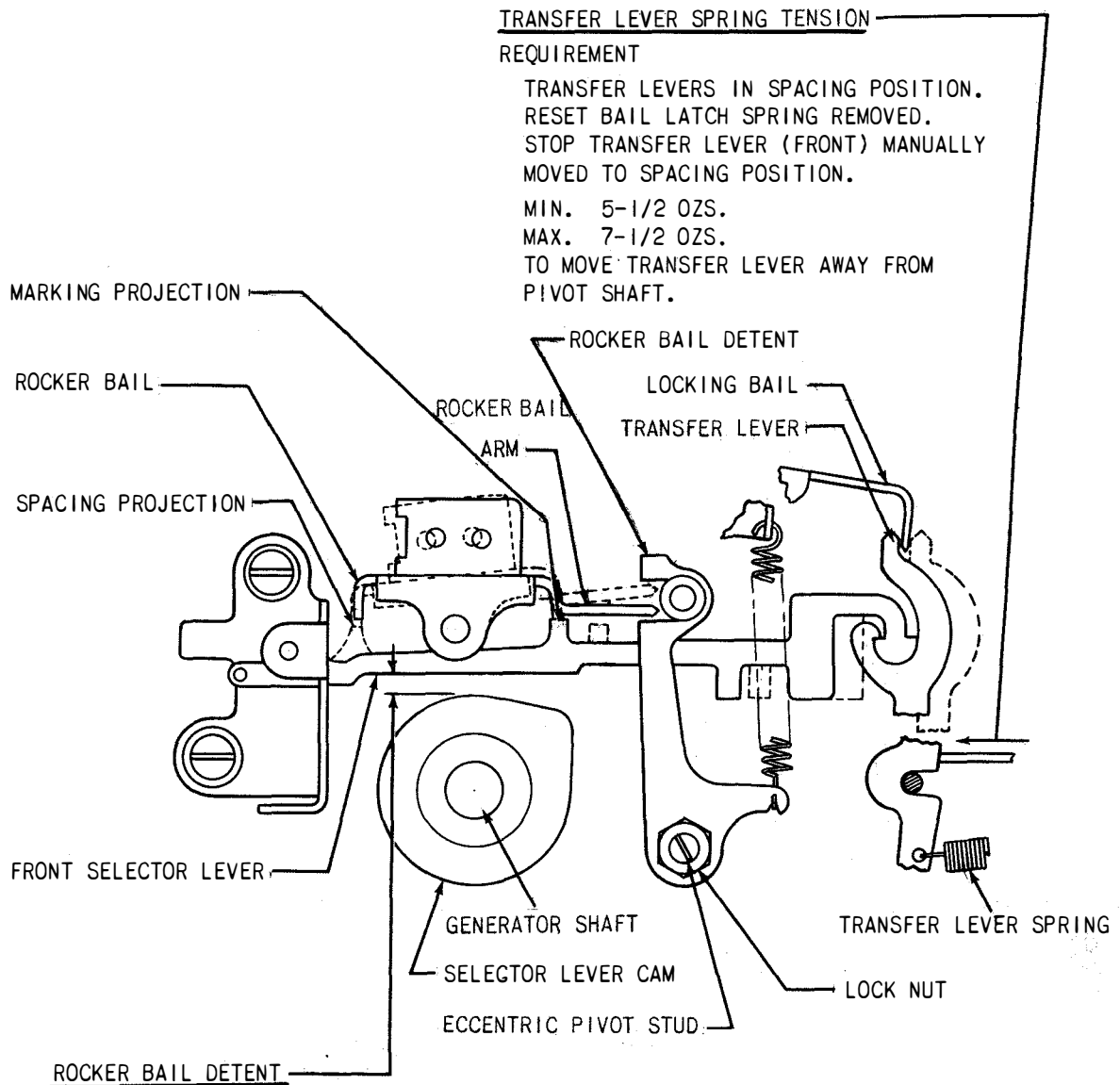


Figure 7-1. Keyboard, Signal Generator, Front View





**TRANSFER LEVER SPRING TENSION  
REQUIREMENT**  
 TRANSFER LEVERS IN SPACING POSITION.  
 RESET BAIL LATCH SPRING REMOVED.  
 STOP TRANSFER LEVER (FRONT) MANUALLY  
 MOVED TO SPACING POSITION.  
 MIN. 5-1/2 OZS.  
 MAX. 7-1/2 OZS.  
 TO MOVE TRANSFER LEVER AWAY FROM  
 PIVOT SHAFT.

**ROCKER BAIL DETENT**

**REQUIREMENT**

CLEARANCE BETWEEN THE ROCKER BAIL ARM AND BOTH THE MARKING AND THE SPACING PROJECTIONS OF THE SELECTOR LEVERS SHOULD BE EQUAL WITHIN 0.005 INCH.

**TO CHECK**

ROTATE THE CAM SLEEVE UNTIL THE FRONT SELECTOR LEVER IS OPPOSITE THE LOW PART OF THE CAM. WITH THE FRONT SELECTOR LEVER IN THE MARKING (LEFT) POSITION, AND THE ROCKER BAIL ARM AGAINST THE LOWER STOP OF ITS DETENT, HOLD THE SELECTOR LEVER LIGHTLY UP AGAINST THE ROCKER BAIL AND GAUGE THE CLEARANCE BETWEEN THE SELECTOR LEVER AND THE CAM. SHIFT THE ROCKER BAIL ARM AGAINST THE UPPER STOP OF ITS DETENT AND HOLD THE FRONT SELECTOR LEVER TO THE RIGHT AND UP SO THAT THE SPACING PROJECTION TOUCHES THE ROCKER BAIL. GAUGE THE CLEARANCE BETWEEN THE SELECTOR LEVER AND THE CAM. THESE TWO CLEARANCES SHOULD BE EQUAL WITHIN 0.005 INCH.

**TO ADJUST**

EQUALIZE CLEARANCES BY ROTATING THE ECCENTRIC PIVOT STUD OF THE DETENT WITH ITS LOCK NUT LOOSENED. KEEP THE HIGH PART OF THE ECCENTRIC TOWARD GENERATOR SHAFT.

**Figure 7-2. Keyboard, Signal Generator, Front View**

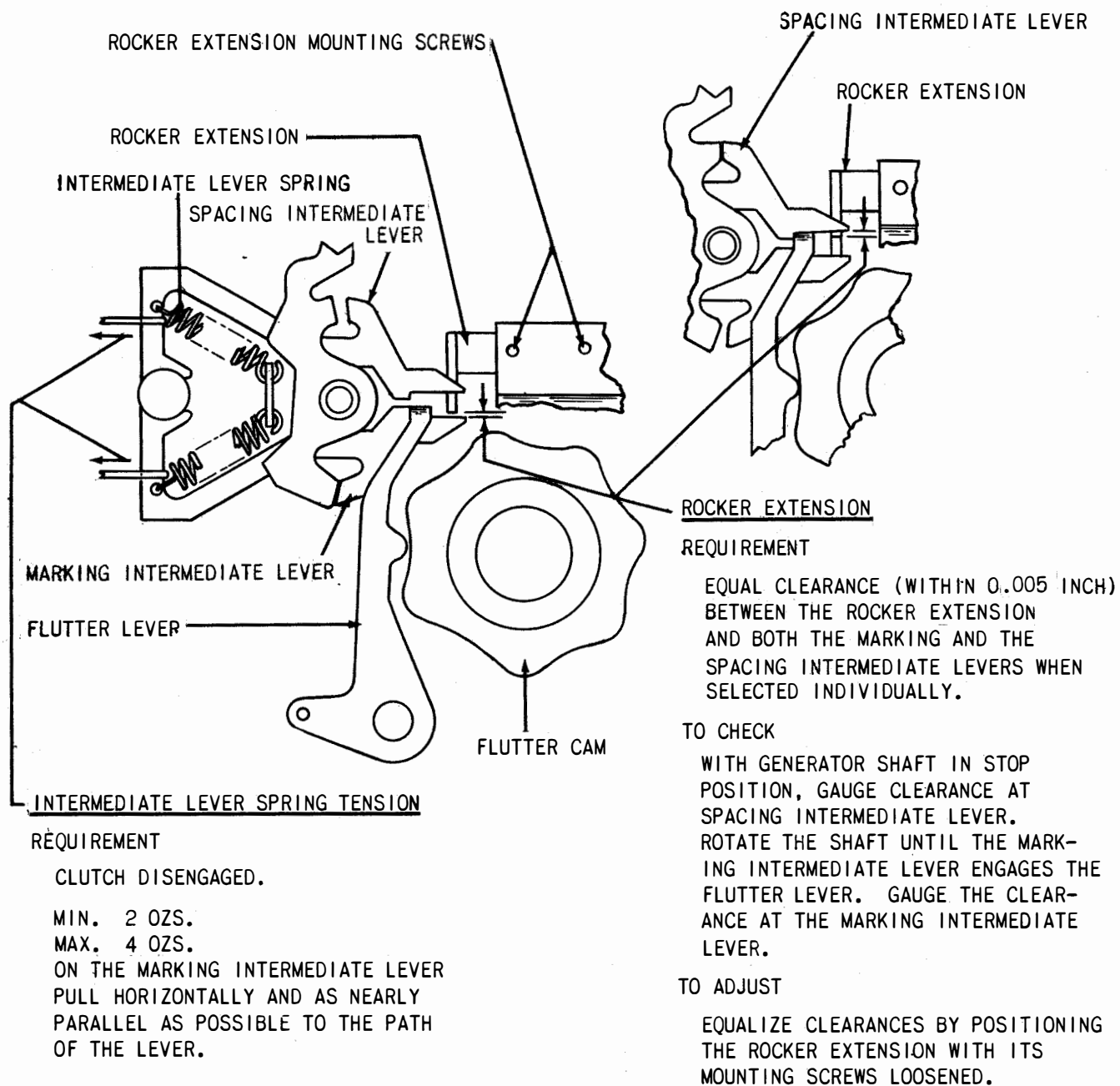


Figure 7-3. Keyboard, Signal Generator, Rear View

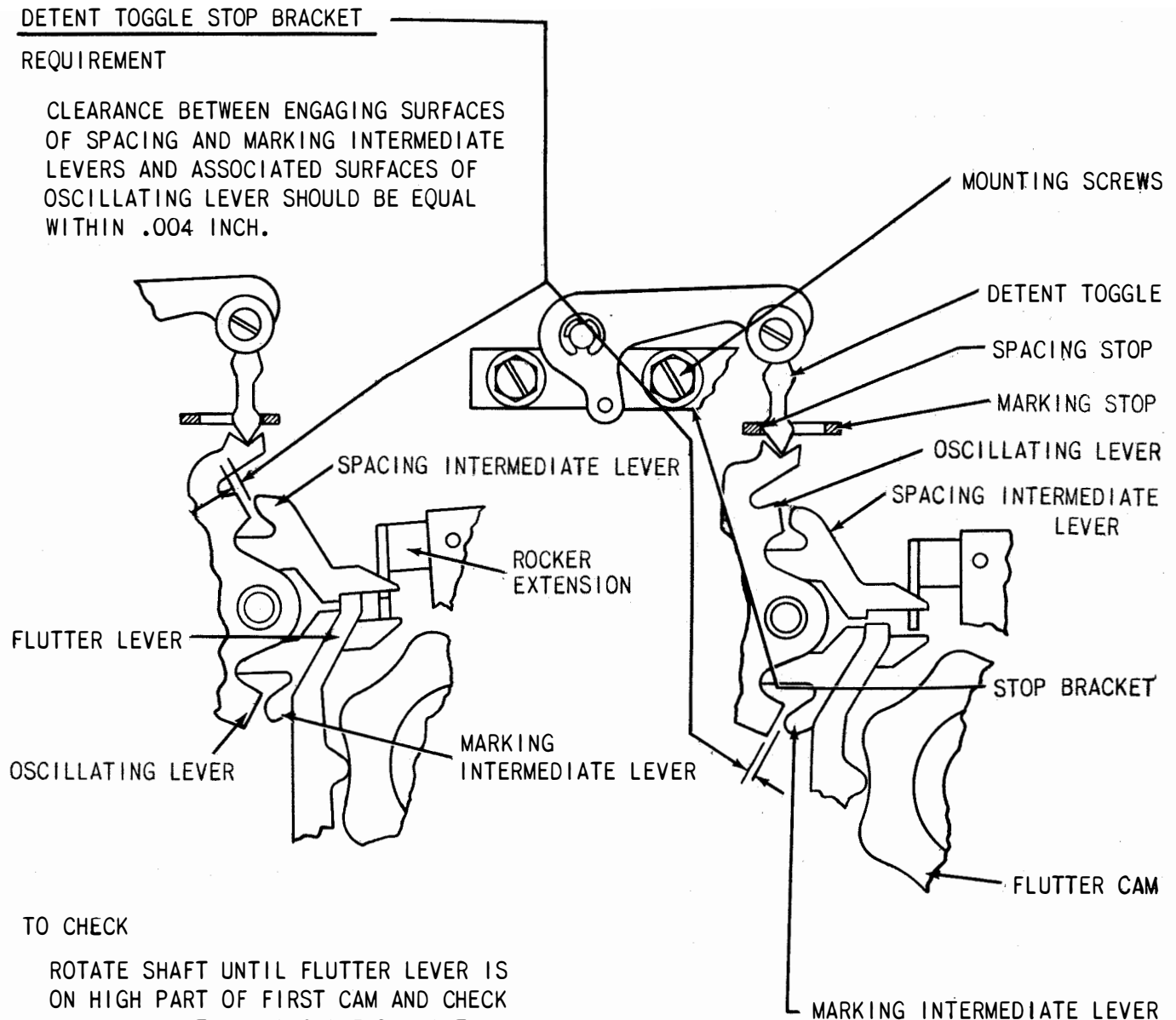


Figure 7-4. Keyboard, Signal Generator, Rear View

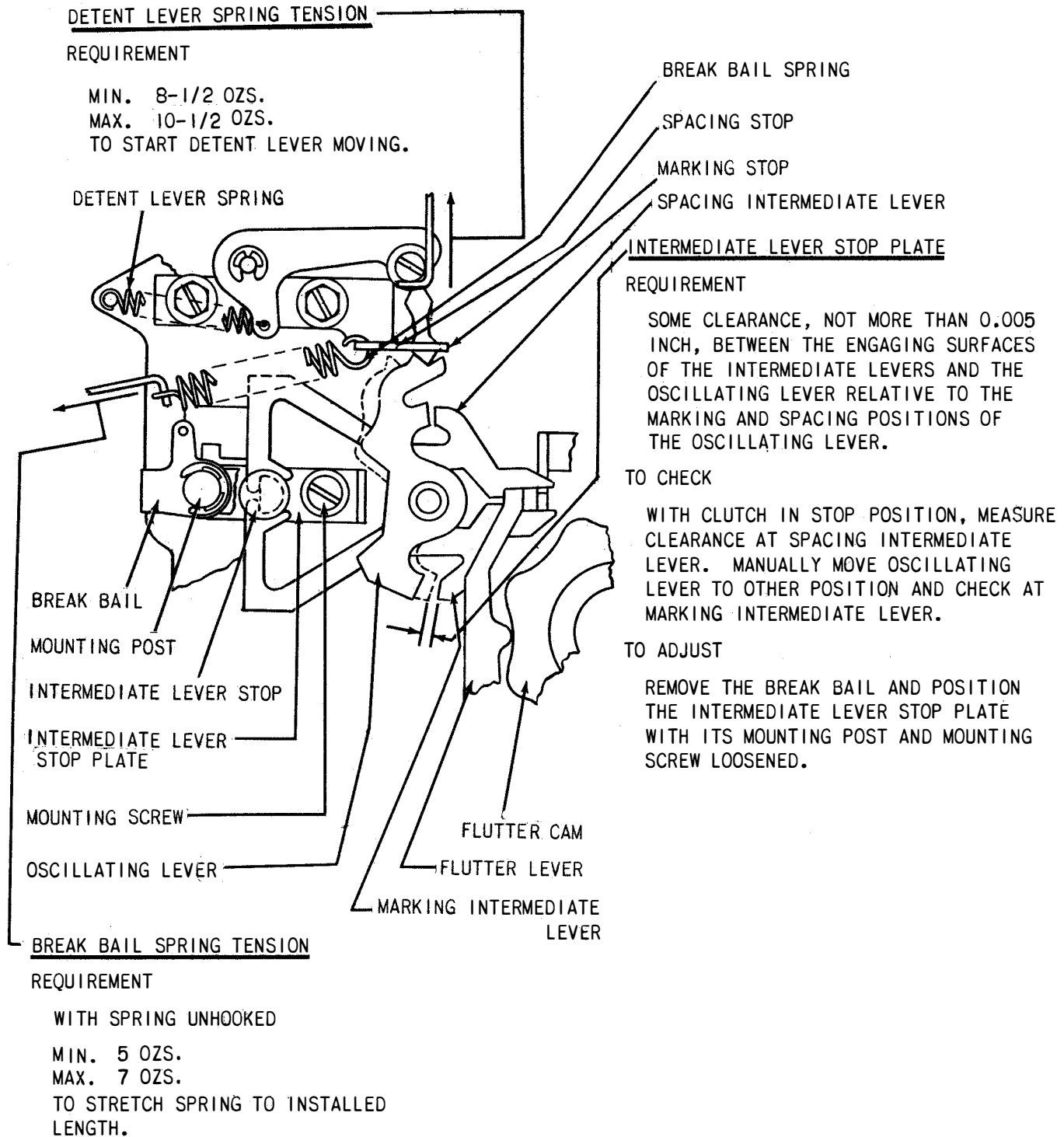
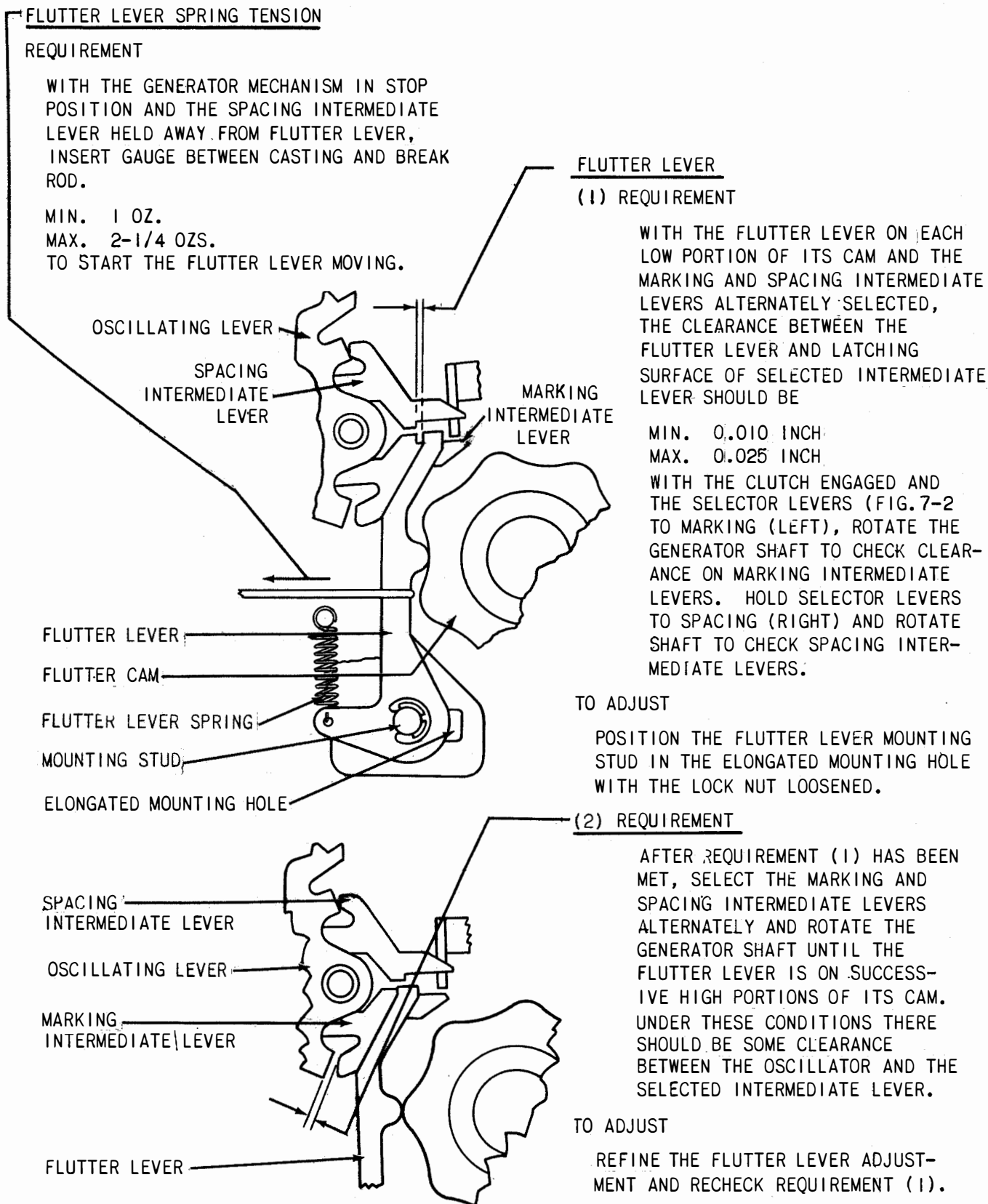
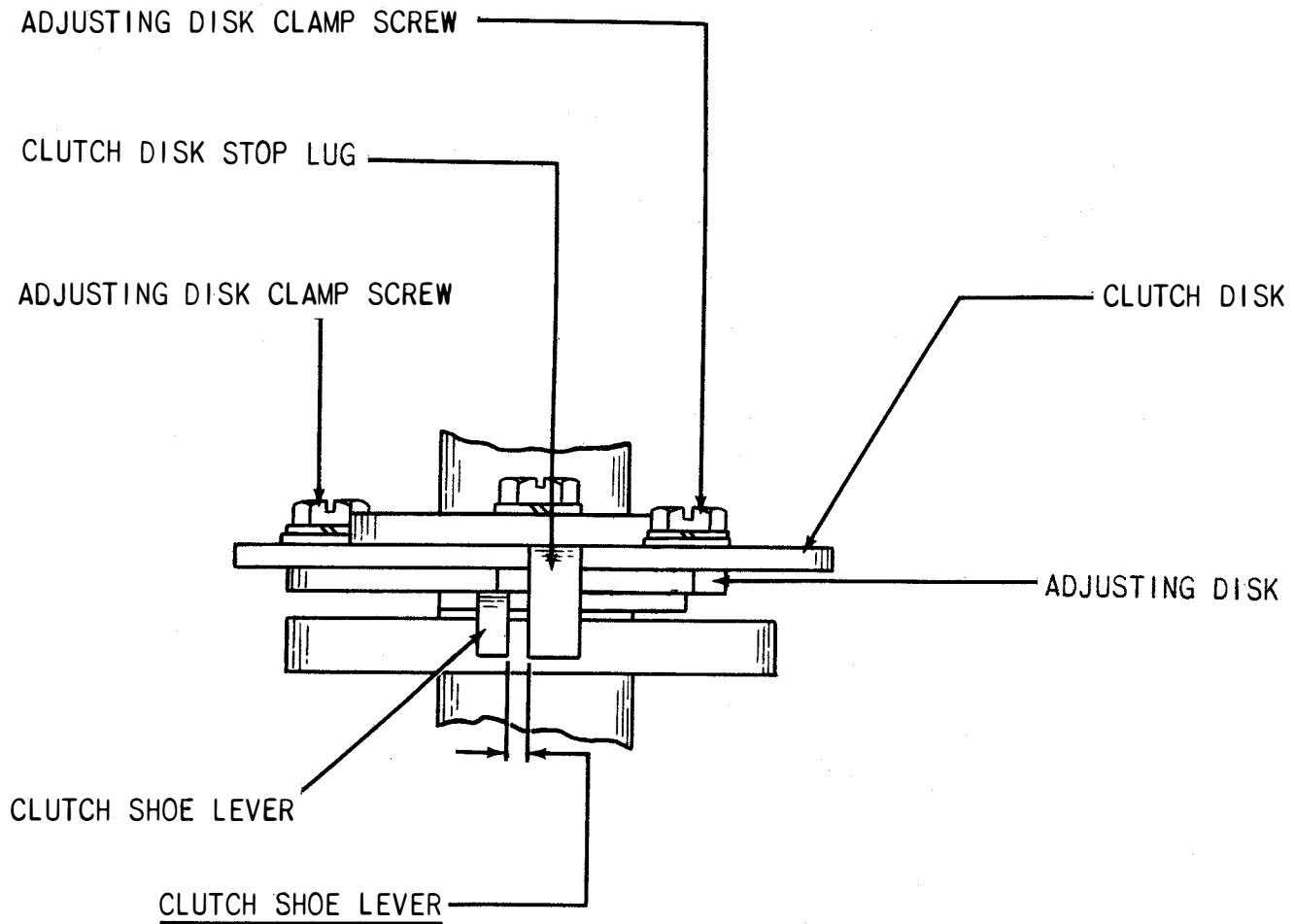


Figure 7-5. Keyboard, Signal Generator, Rear View



**Figure 7-6. Keyboard, Signal Generator, Rear View**

CLUTCH SHOE LEVER  
REQUIREMENT

CLUTCH STOP LEVER (FIG. 7-8) TRIPPED (CLUTCH ENGAGED).  
CLEARANCE BETWEEN CLUTCH SHOE LEVER AND CLUTCH STOP LUG.

MIN. 0.090 INCH  
MAX. 0.110 INCH

## TO ADJUST

ROTATE THE ADJUSTING DISK WITH THE CLAMP SCREWS LOOSENED.  
USE GAUGE 151379.

**Figure 7-7. Keyboard, Clutch Mechanism**

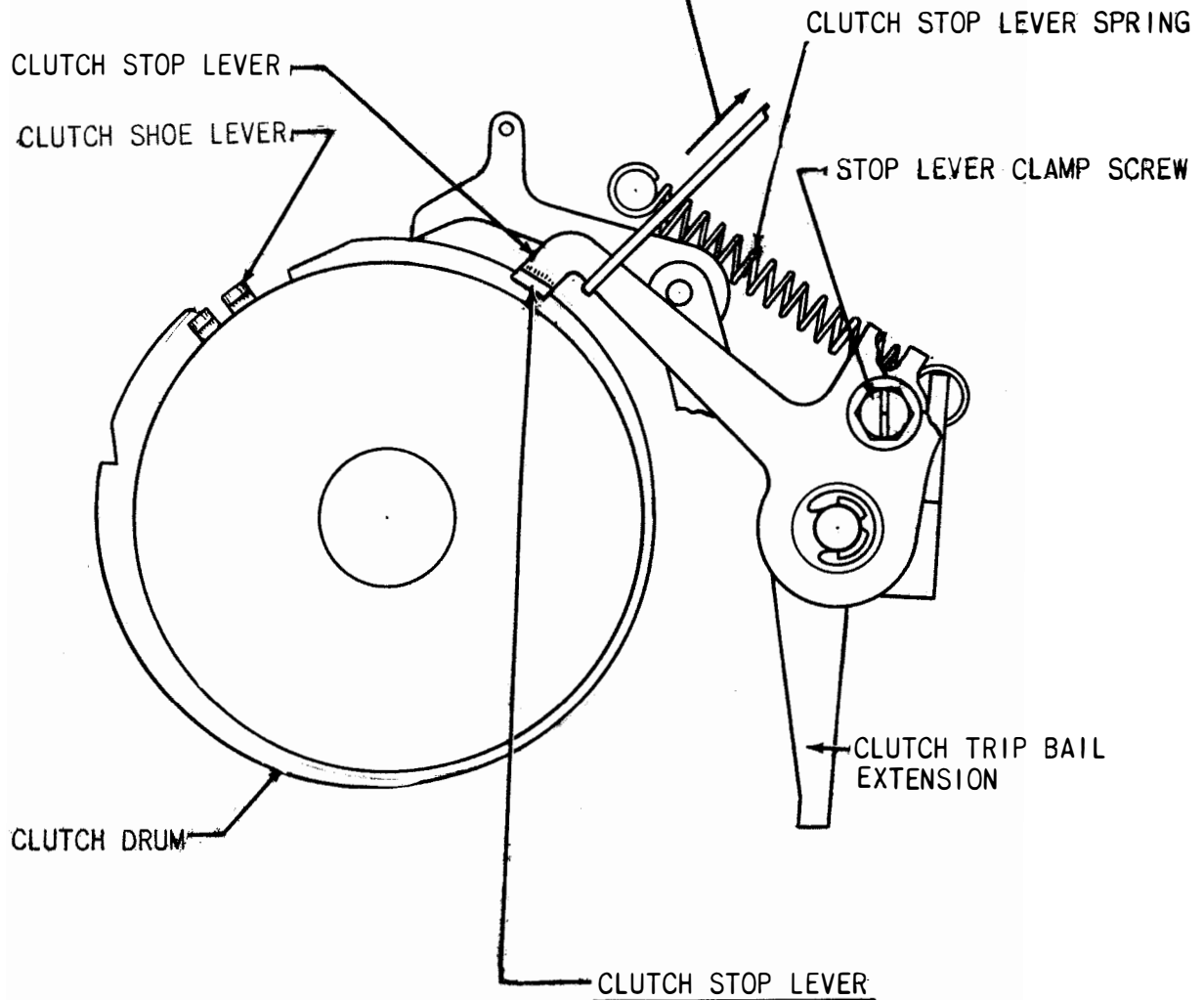
CLUTCH STOP LEVER SPRING TENSION  
REQUIREMENT

OPERATE CLUTCH STOP LEVER, CLUTCH  
ENGAGED, ROTATE SHAFT 1/4 TURN.

MIN. 3 OZS.

MAX. 3-1/2 OZS.

TO START THE LEVER MOVING.



REQUIREMENT

CLUTCH STOP LEVER SHOULD FULLY EN-  
GAGE THE CLUTCH SHOE LEVER VERTICALLY.

TO ADJUST

POSITION THE STOP LEVER WITH ITS  
CLAMP SCREW LOOSENED.

Figure 7-8. Keyboard, Clutch Mechanism

CLUTCH THROWOUT BAIL PAWL SPRING TENSION

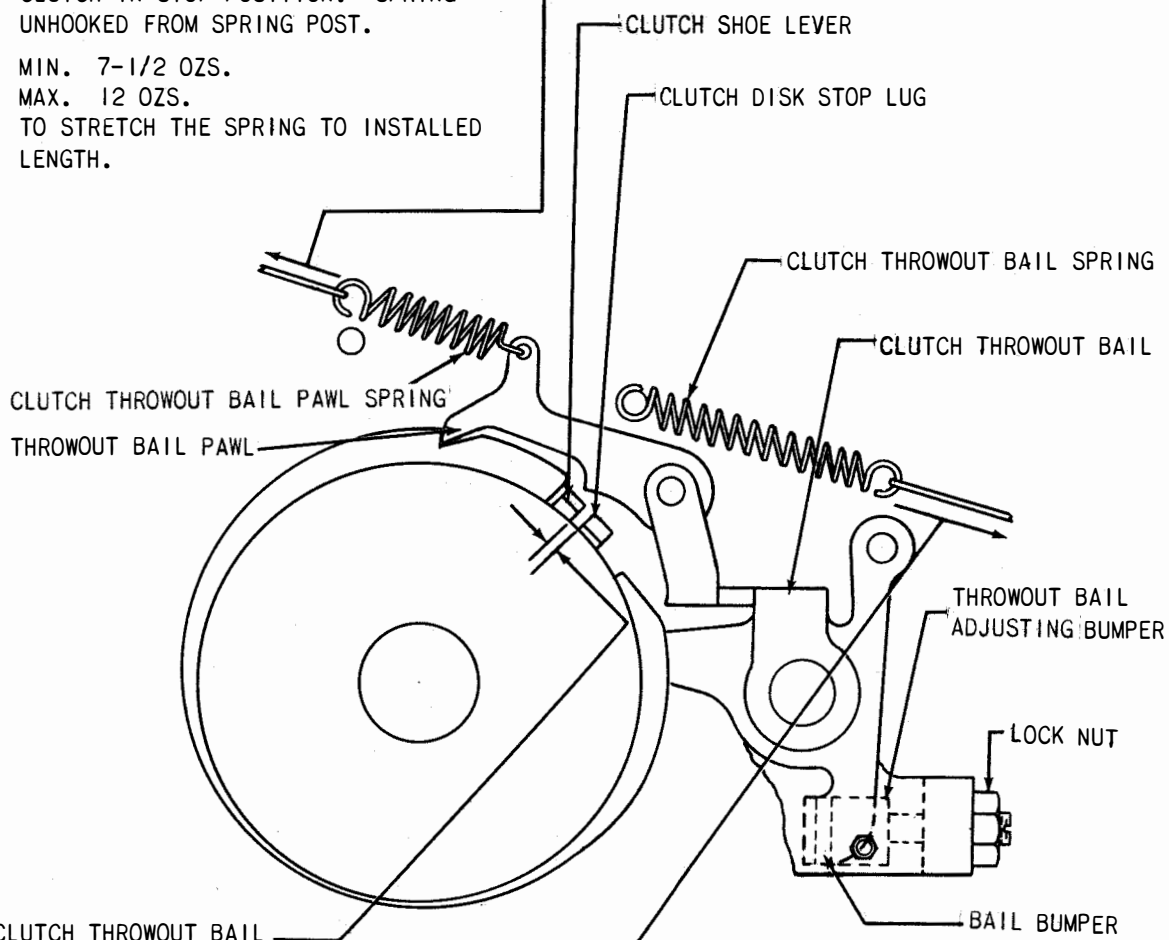
REQUIREMENT

CLUTCH IN STOP POSITION. SPRING UNHOOKED FROM SPRING POST.

MIN. 7-1/2 OZS.

MAX. 12 OZS.

TO STRETCH THE SPRING TO INSTALLED LENGTH.



CLUTCH THROWOUT BAIL

REQUIREMENT

WITH THE CLUTCH IN ITS STOP POSITION, THROWOUT BAIL PAWL IN THE BOTTOM OF ITS NOTCH, CLUTCH STOP LEVER AGAINST CLUTCH SHOE LEVER, AND CLUTCH HELD DISENGAGED. SOME CLEARANCE BETWEEN CLUTCH SHOE LEVER AND CLUTCH DISK STOP LUG.

MAX. 0.020 INCH

TO ADJUST

POSITION THE THROWOUT BAIL ADJUSTING BUMPER WITH ITS LOCK NUT LOOSENED.

CLUTCH THROWOUT BAIL SPRING TENSION

REQUIREMENT

SPRING REMOVED FROM CLUTCH THROWOUT BAIL AND BAIL HELD AGAINST ADJUSTING BUMPER.

MIN. 14 OZS.

MAX. 17-1/2 OZS.

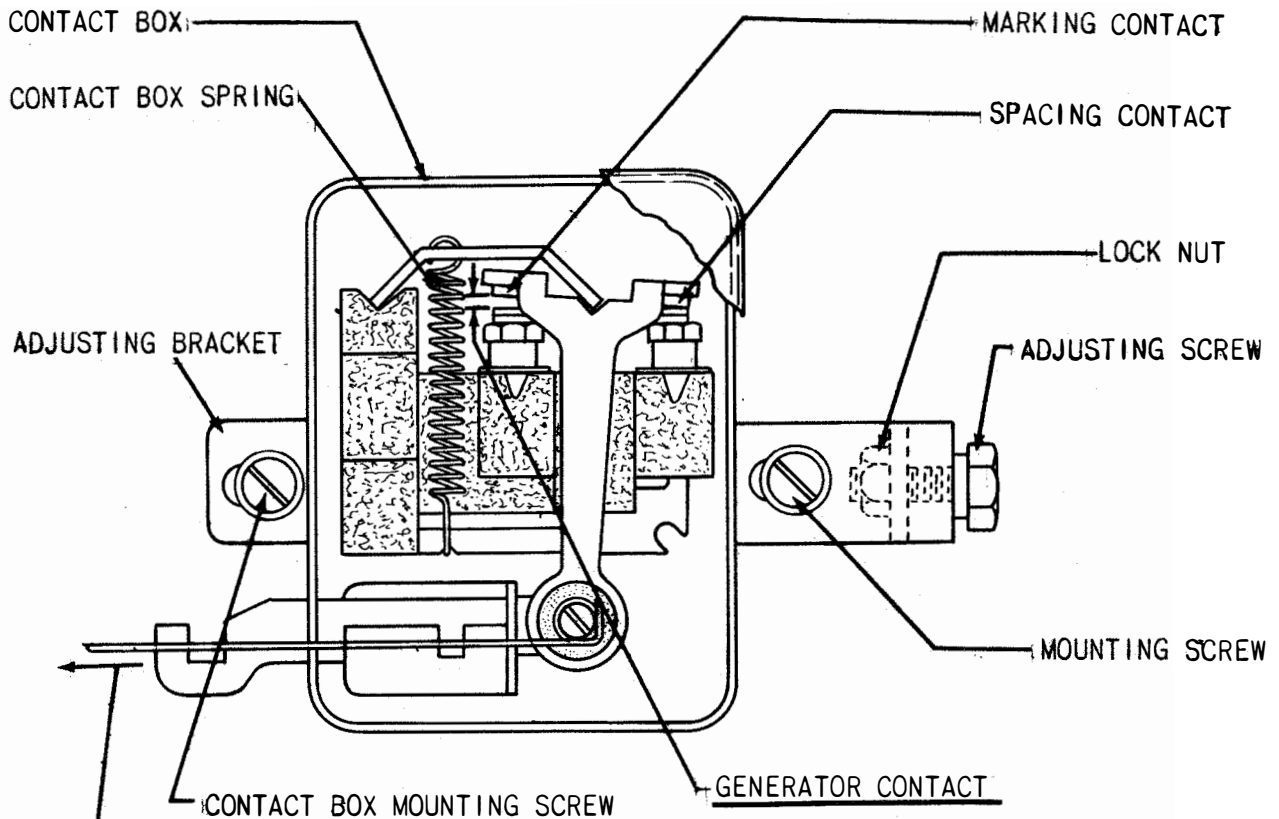
TO STRETCH THE SPRING TO ITS INSTALLED LENGTH.

NOTE

REPLACE SIGNAL GENERATOR ON THE KEYBOARD. MAKE CERTAIN THAT THE RESET BAIL LATCH LEVER (FIG. 7-11) IS UNDER THE CODE LEVER BAIL LATCH LEVER (FIG. 7-13), THAT THE BREAK KEY ROD (ATTACHED TO BREAK BAIL FIG. 7-5 ) IS IN ITS GUIDE HOLE IN THE CODE LEVER GUIDE, AND THAT THE CLUTCH TRIP BAIL EXTENSION (FIG. 7-8) IS IN THE NOTCH PROVIDED IN THE UNIVERSAL (REAR) CODE BAR.

Figure 7-9. Keyboard, Clutch Mechanism





**REQUIREMENT**

THE MARKING AND SPACING CONTACT GAPS SHOULD BE EQUAL WITHIN 0.002 INCH.

**TO CHECK**

REMOVE THE COVER FROM THE CONTACT BOX. FIRST MOVE THE DETENT TOGGLE AGAINST ITS SPACING STOP (LEFT AS VIEWED FROM REAR) AND GAUGE THE MARKING CONTACT GAP. THEN MOVE THE DETENT TOGGLE AGAINST ITS MARKING STOP AND GAUGE SPACING CONTACT GAP.

**TO ADJUST**

ROTATE THE ADJUSTING SCREW WITH ITS LOCK NUT LOOSENED AND WITH THE CONTACT BOX MOUNTING SCREWS FRICTION TIGHT. REPLACE CONTACT BOX COVER.

**CAUTION**

CHECK BY MEANS OF A SIGNAL CHECKING DEVICE WHERE POSSIBLE AND CAREFULLY REFINE THE ADJUSTMENT TO ELIMINATE ALL BIAS FROM THE SIGNALS BY EQUALIZING THE CURRENT-ON AND CURRENT-OFF INTERVALS.

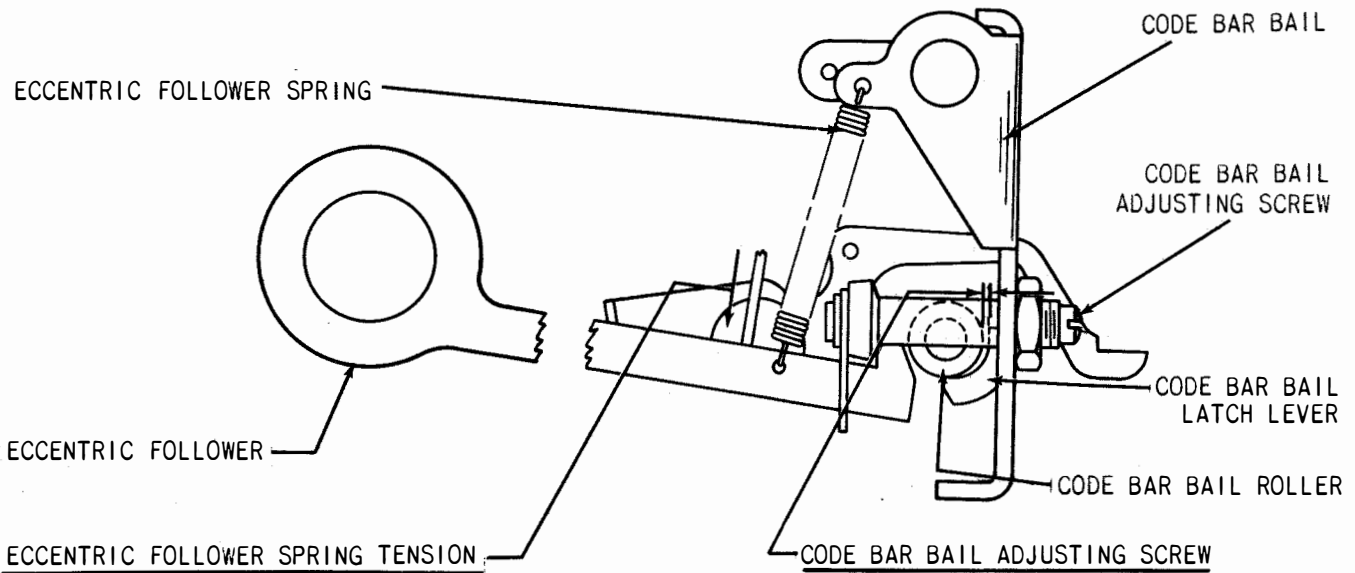
**CONTACT BOX SPRING TENSION**

**REQUIREMENT**

CONTACT BOX COVER REMOVED. DETENT TOGGLE SPRING DISCONNECTED.

MIN. 3 OZS.  
MAX. 4-1/2 OZS.  
TO BREAK CONTACT.

**Figure 7-10. Keyboard, Contact Assembly**



ECCENTRIC FOLLOWER SPRING TENSION

REQUIREMENT

CLUTCH DISENGAGED

MIN. 1 OZ.  
MAX. 2 OZS.

TO START THE ECCENTRIC FOLLOWER  
MOVING.

CODE BAR BAIL ADJUSTING SCREW

REQUIREMENT

CLUTCH ENGAGED. ROTATE CLUTCH 1/2  
TURN UNTIL ECCENTRIC FOLLOWER IS IN  
EXTREME LEFT-HAND POSITION.  
CLEARANCE BETWEEN THE CODE BAR BAIL  
LATCH LEVER AND CODE BAR BAIL ROLLER.

MIN. 0.004 INCH  
MAX. 0.008 INCH

TO ADJUST

POSITION THE CODE BAR BAIL ADJUSTING  
SCREW WITH ITS LOCK NUT LOOSENED.

**Figure 7-11. Keyboard, Code Bar Bail Mechanism**

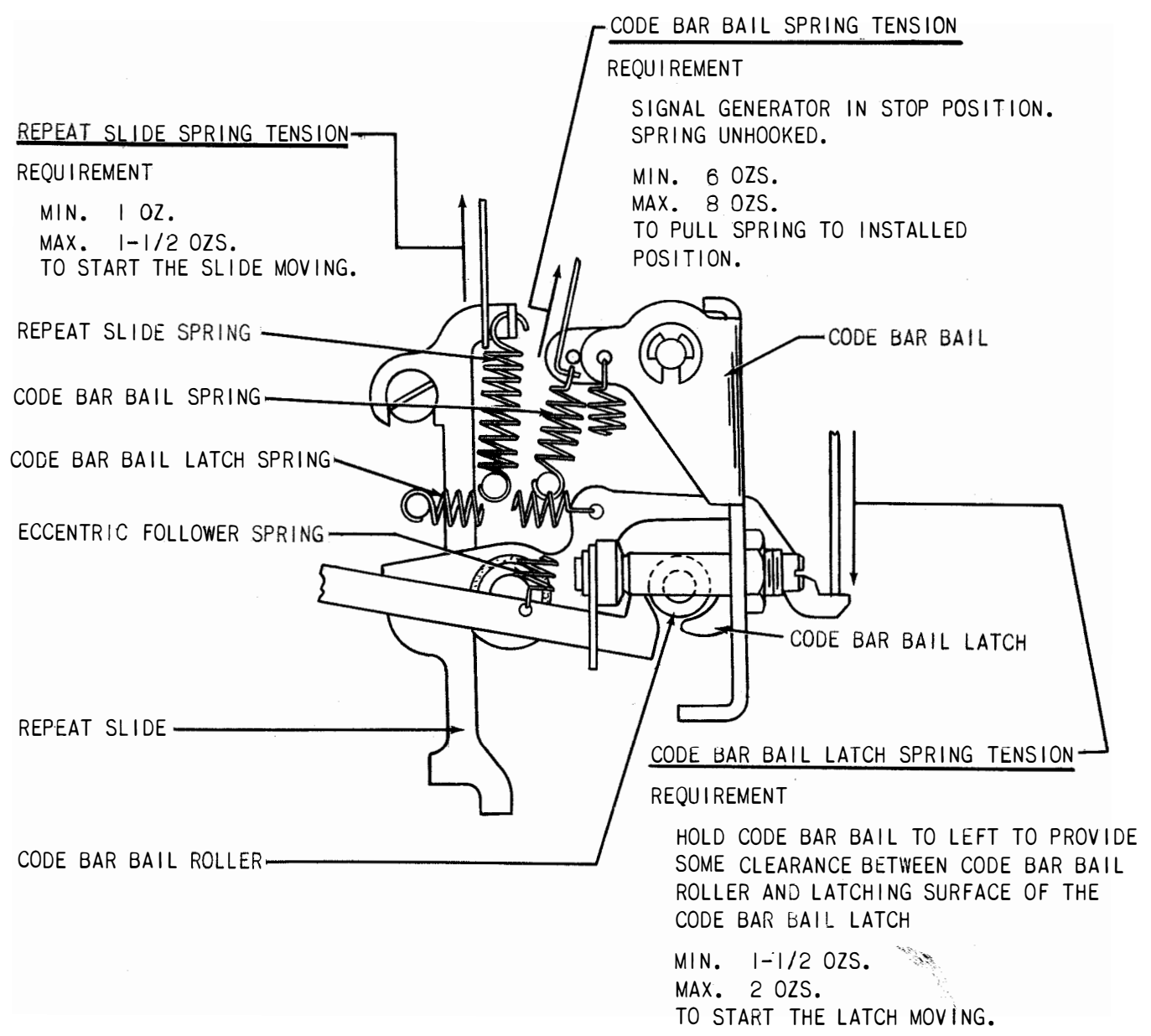


Figure 7-12. Keyboard, Code Bar Bail and Repeat Slide

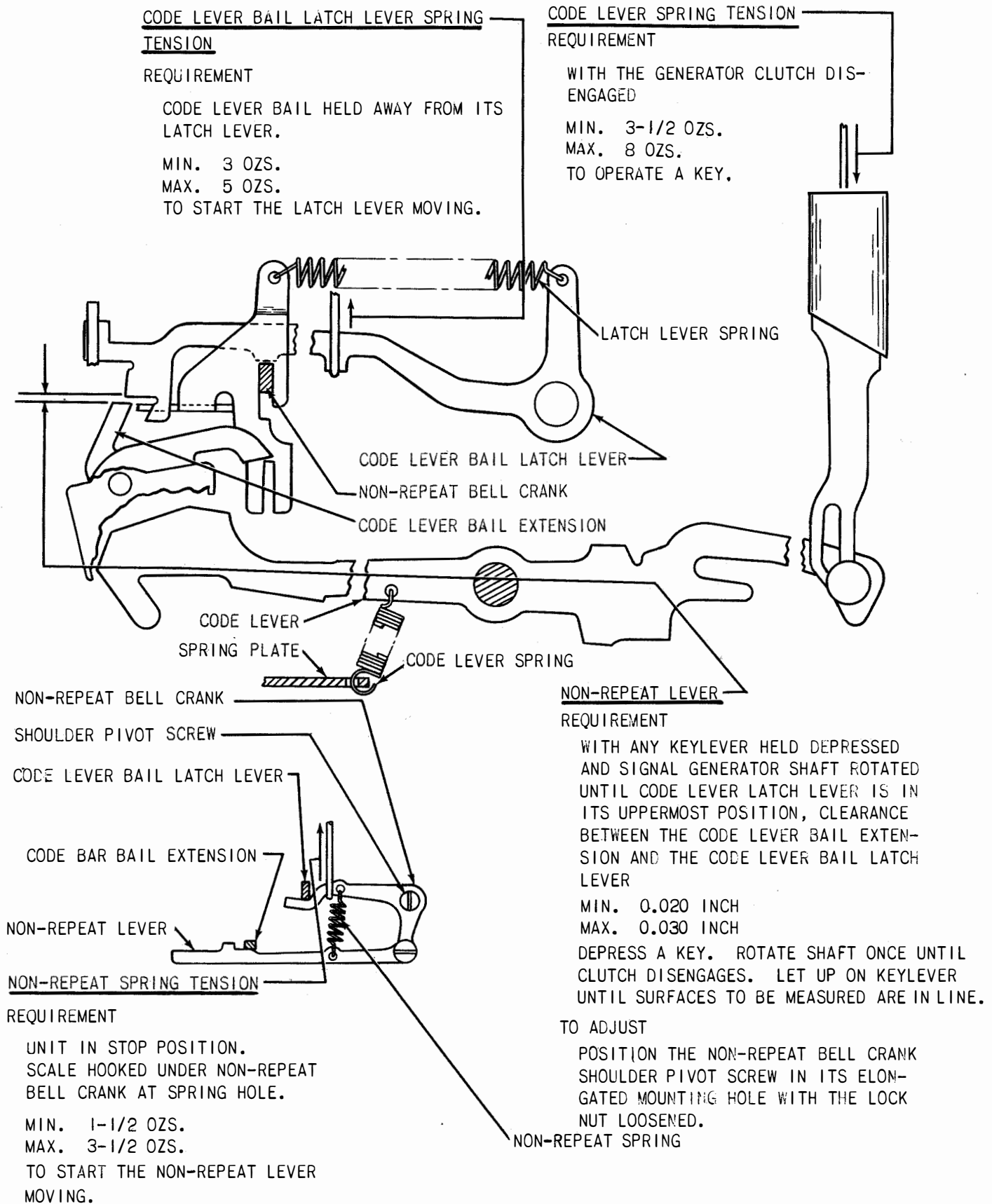
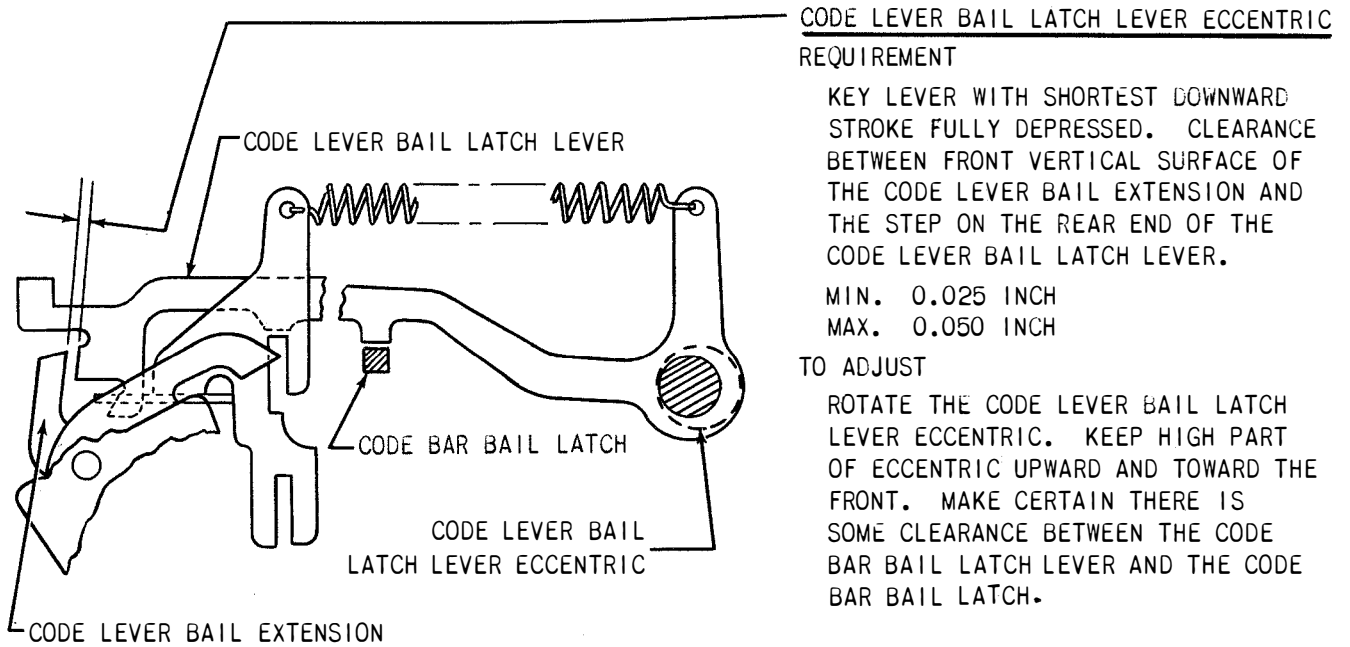
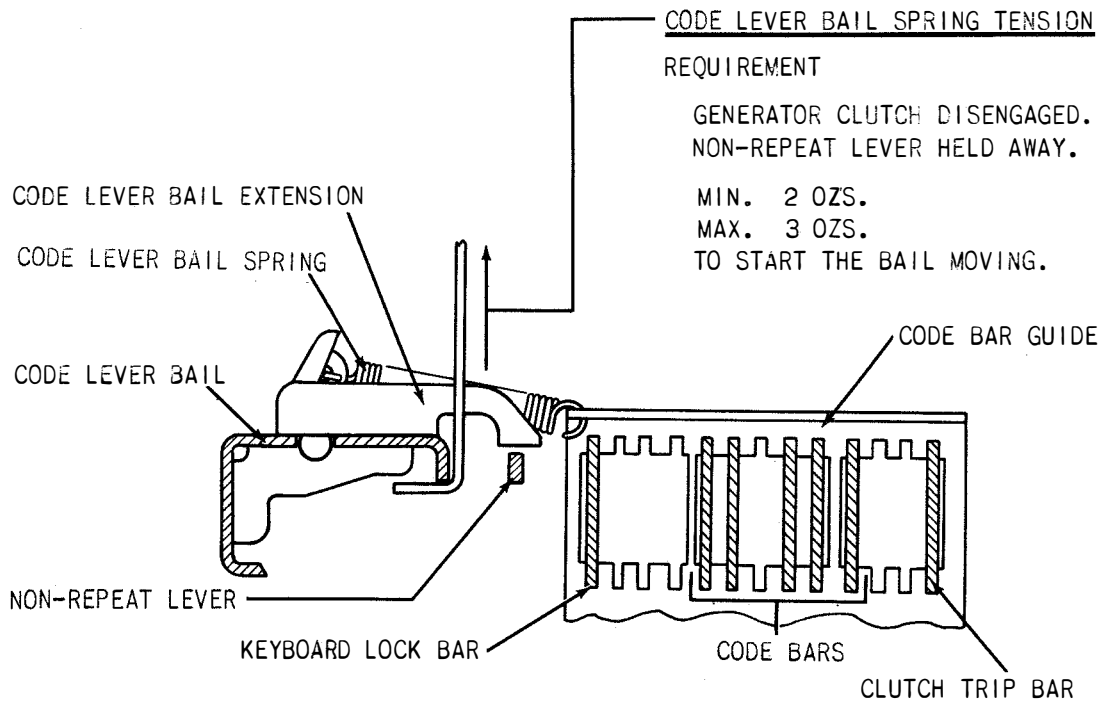


Figure 7-13. Keyboard, Non-Repeat Mechanism



**Figure 13A. Keyboard, Non-Repeat Mechanism**



**Figure 7-14. Keyboard, Code Bar Mechanism**

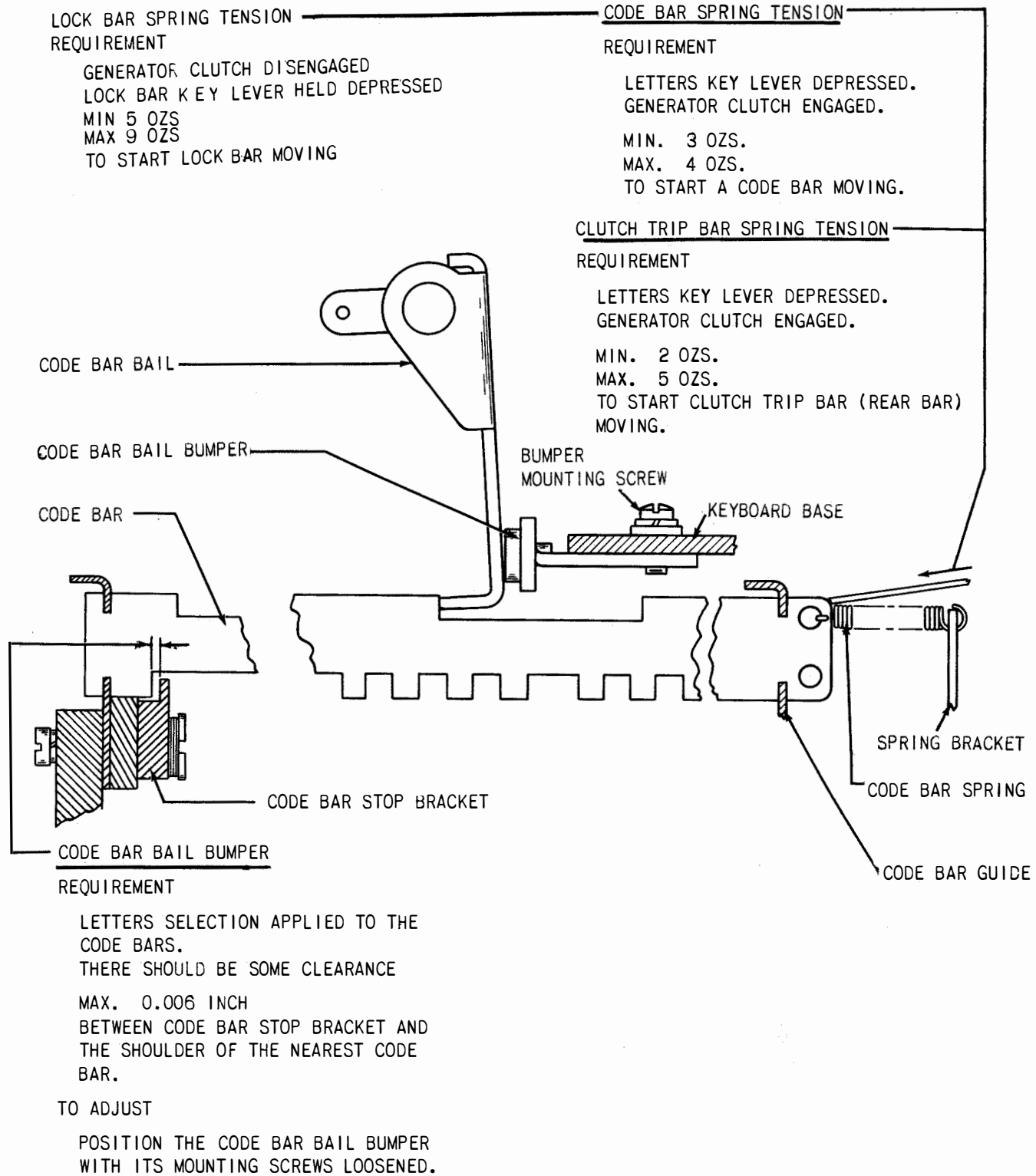


Figure 7-15. Keyboard, Code Bar Mechanism

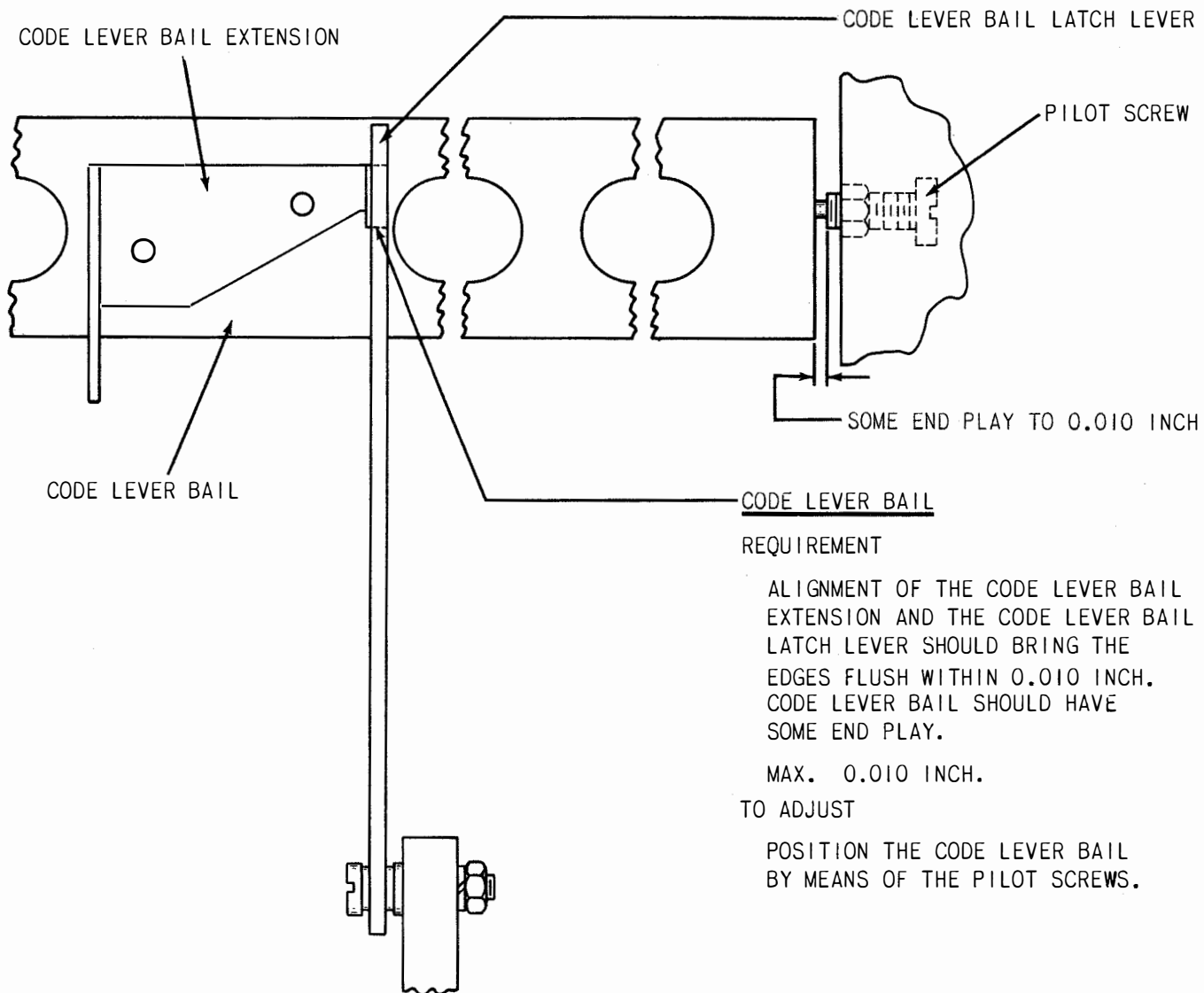
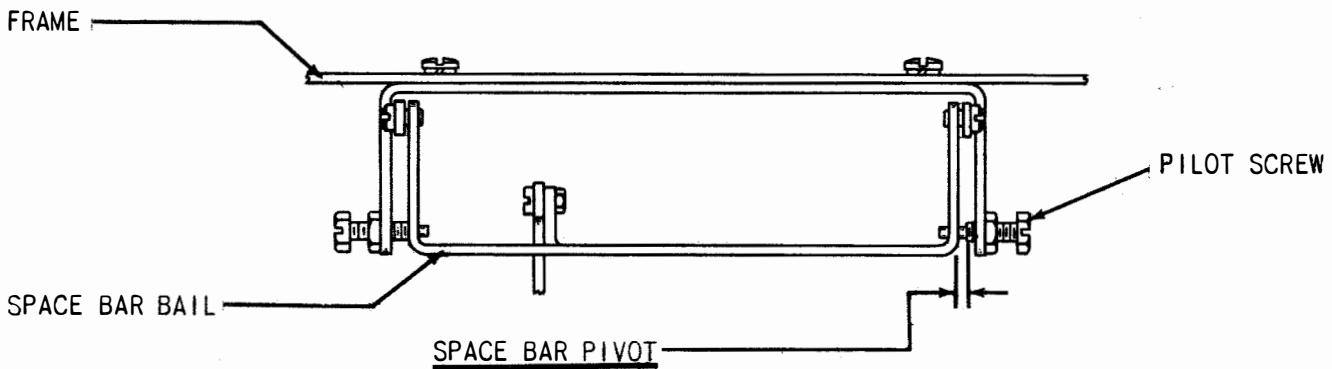


Figure 7-16. Keyboard, Code Lever Bail



REQUIREMENT

THE SPACE BAR SHOULD BE FREE ON ITS PIVOTS AND HAVE SOME END PLAY, ALSO FREE FROM BINDING IN SLOTS OF KEY-TOP GUIDE PLATE.

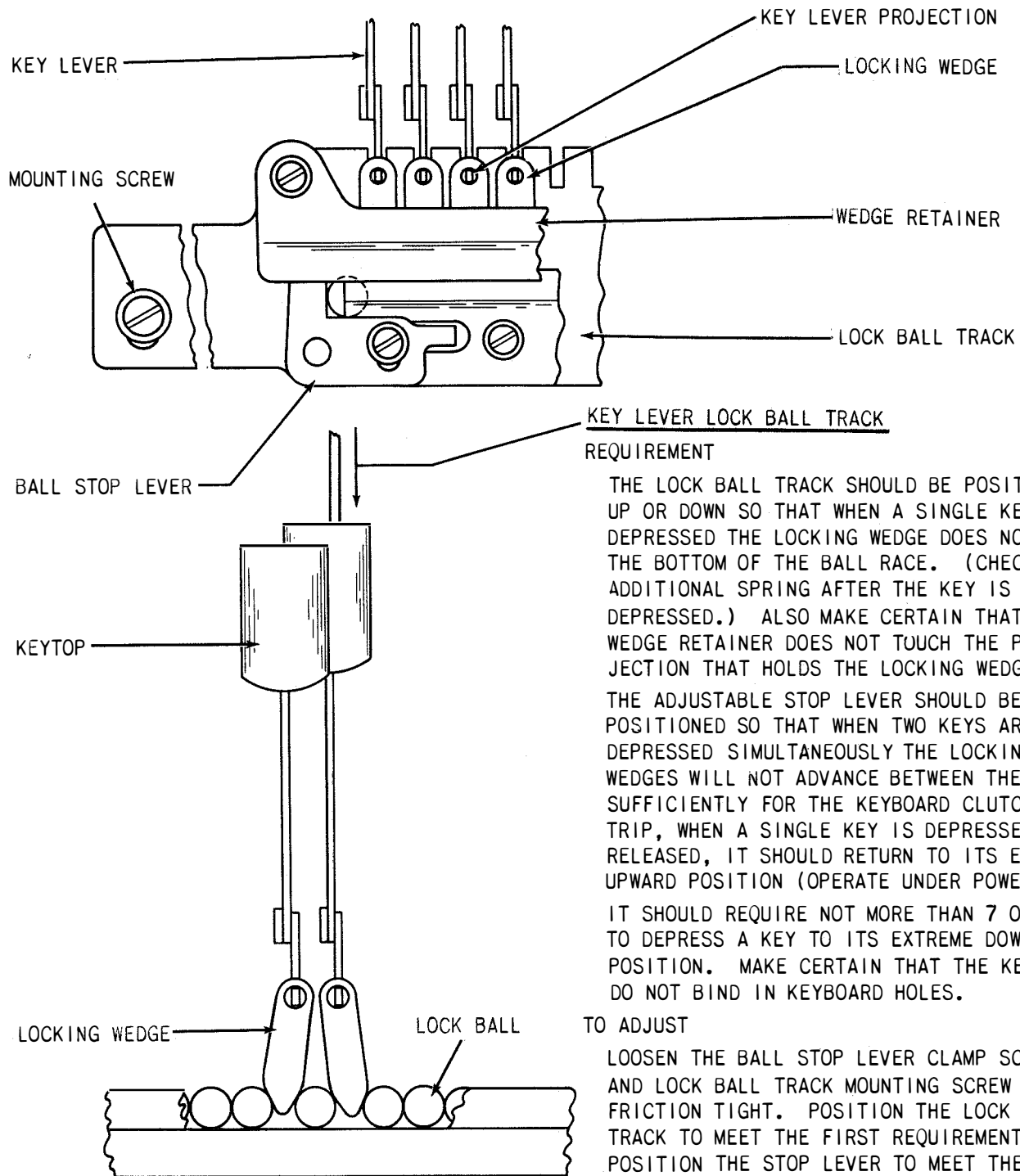
MAX. 0.010 INCH

TO ADJUST

POSITION THE SPACE BAR BAIL PILOT SCREWS.

**Figure 7-17. Keyboard, Space Bar**





**KEY LEVER LOCK BALL TRACK  
REQUIREMENT**

THE LOCK BALL TRACK SHOULD BE POSITIONED UP OR DOWN SO THAT WHEN A SINGLE KEY IS DEPRESSED THE LOCKING WEDGE DOES NOT TOUCH THE BOTTOM OF THE BALL RACE. (CHECK FOR ADDITIONAL SPRING AFTER THE KEY IS FULLY DEPRESSED.) ALSO MAKE CERTAIN THAT THE WEDGE RETAINER DOES NOT TOUCH THE PROJECTION THAT HOLDS THE LOCKING WEDGE.

THE ADJUSTABLE STOP LEVER SHOULD BE POSITIONED SO THAT WHEN TWO KEYS ARE DEPRESSED SIMULTANEOUSLY THE LOCKING WEDGES WILL NOT ADVANCE BETWEEN THE BALLS SUFFICIENTLY FOR THE KEYBOARD CLUTCH TO TRIP, WHEN A SINGLE KEY IS DEPRESSED AND RELEASED, IT SHOULD RETURN TO ITS EXTREME UPWARD POSITION (OPERATE UNDER POWER).

IT SHOULD REQUIRE NOT MORE THAN 7 OZS. TO DEPRESS A KEY TO ITS EXTREME DOWNWARD POSITION. MAKE CERTAIN THAT THE KEYTOPS DO NOT BIND IN KEYBOARD HOLES.

**TO ADJUST**

LOOSEN THE BALL STOP LEVER CLAMP SCREW AND LOCK BALL TRACK MOUNTING SCREW FRICTION TIGHT. POSITION THE LOCK BALL TRACK TO MEET THE FIRST REQUIREMENT. POSITION THE STOP LEVER TO MEET THE OTHER REQUIREMENTS.

**Figure 7-18. Keyboard, Key Lever Locking Mechanism**

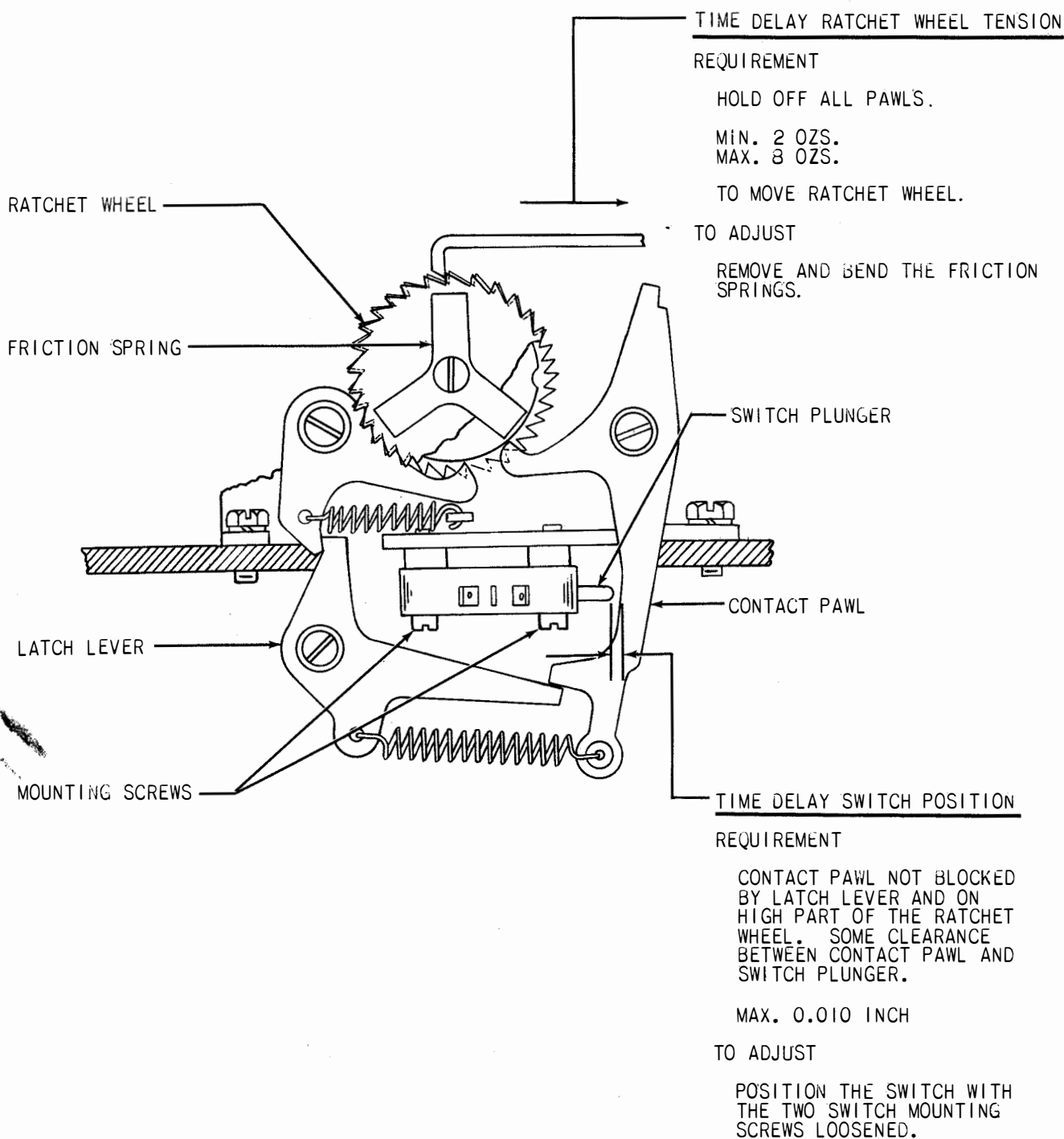
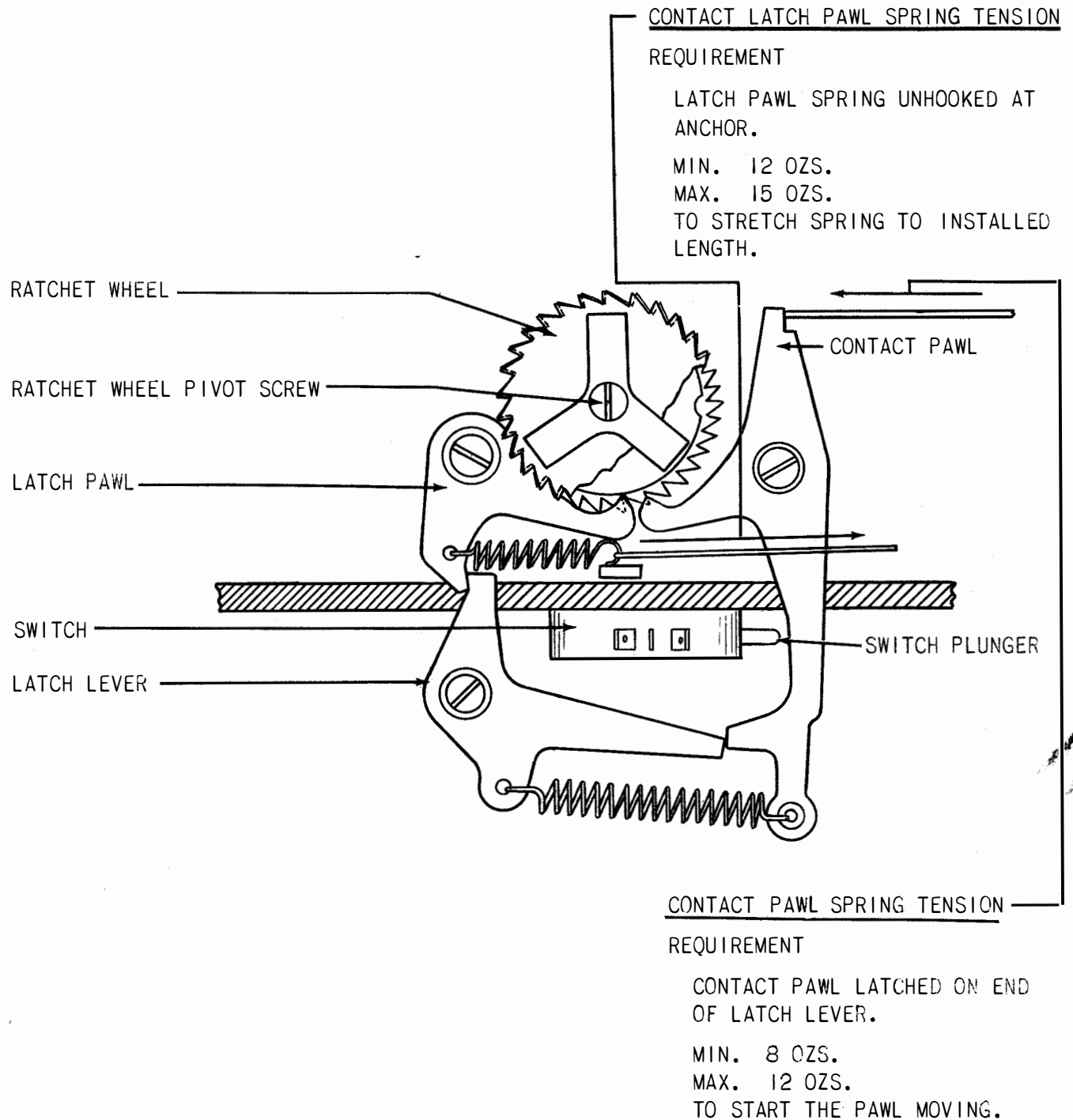
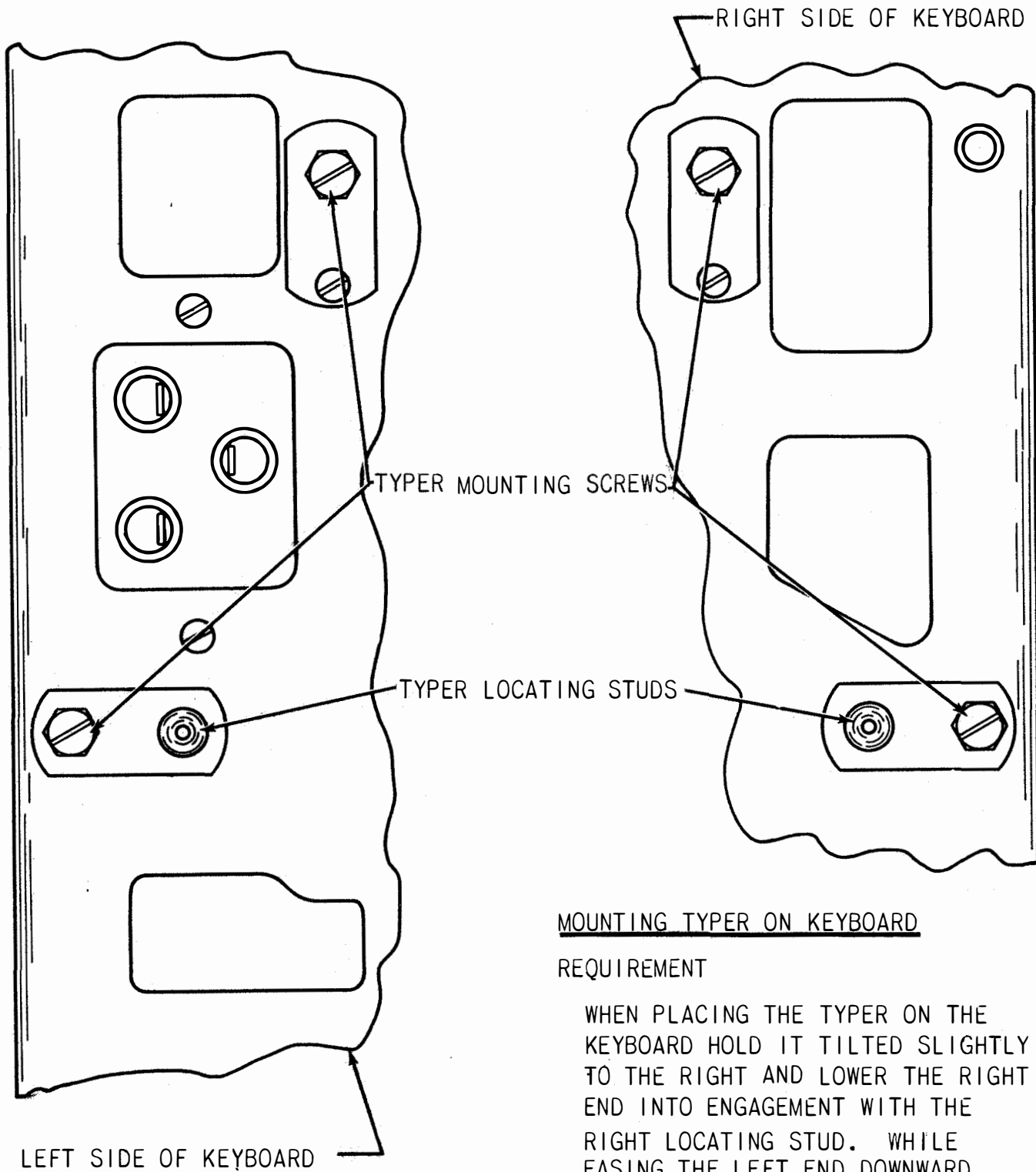


Figure 7-19. Keyboard, Time Delay Mechanism



**Figure 7-20. Keyboard, Time Delay Mechanism**

MOUNTING TYPER ON KEYBOARD

## REQUIREMENT

WHEN PLACING THE TYPER ON THE KEYBOARD HOLD IT TILTED SLIGHTLY TO THE RIGHT AND LOWER THE RIGHT END INTO ENGAGEMENT WITH THE RIGHT LOCATING STUD. WHILE EASING THE LEFT END DOWNWARD ROTATE THE MOTOR BY HAND TO PROPERLY MESH THE GEARS. SECURE BY FOUR MOUNTING SCREWS.

Figure 7-21. Mounting Typewriter on Keyboard

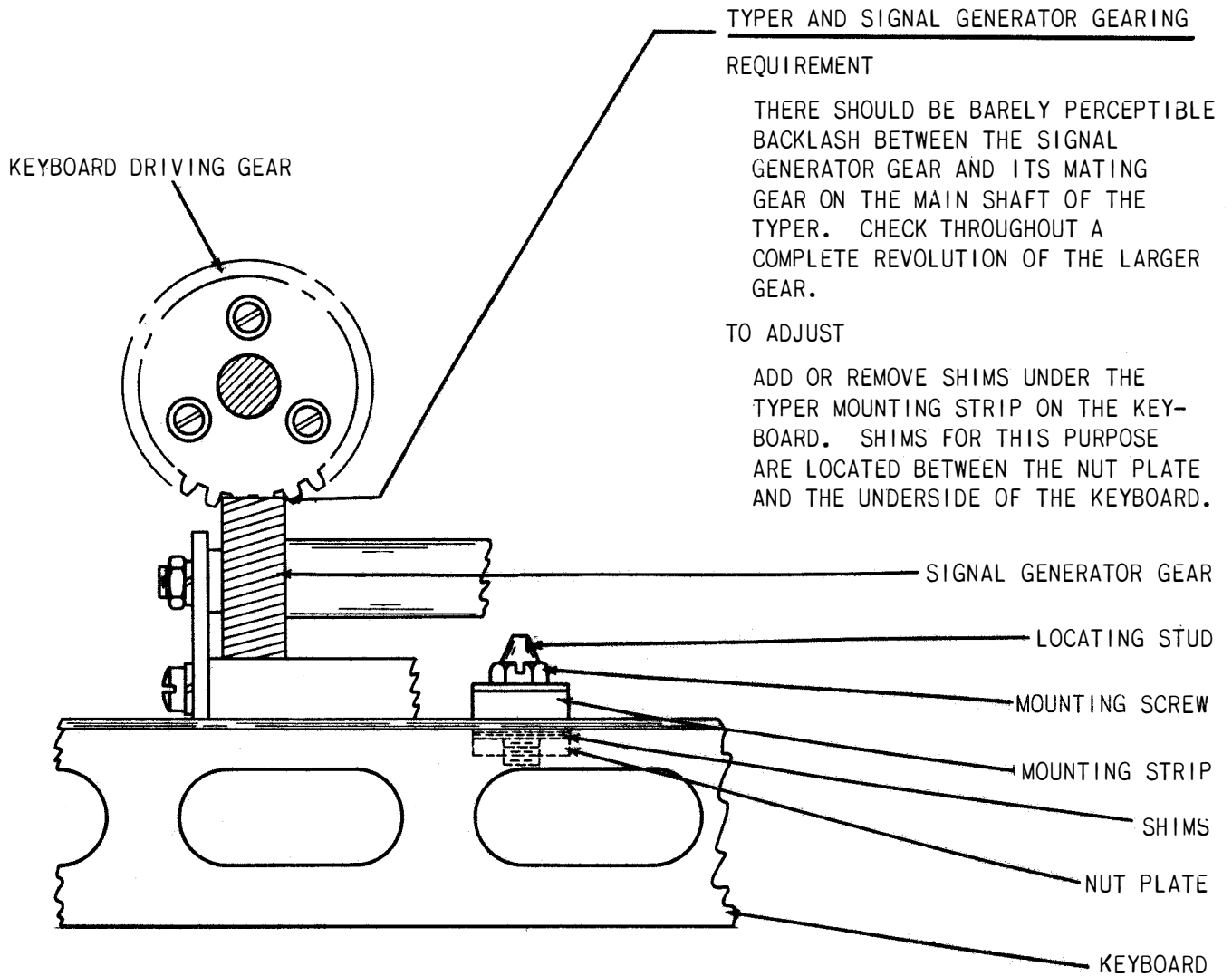
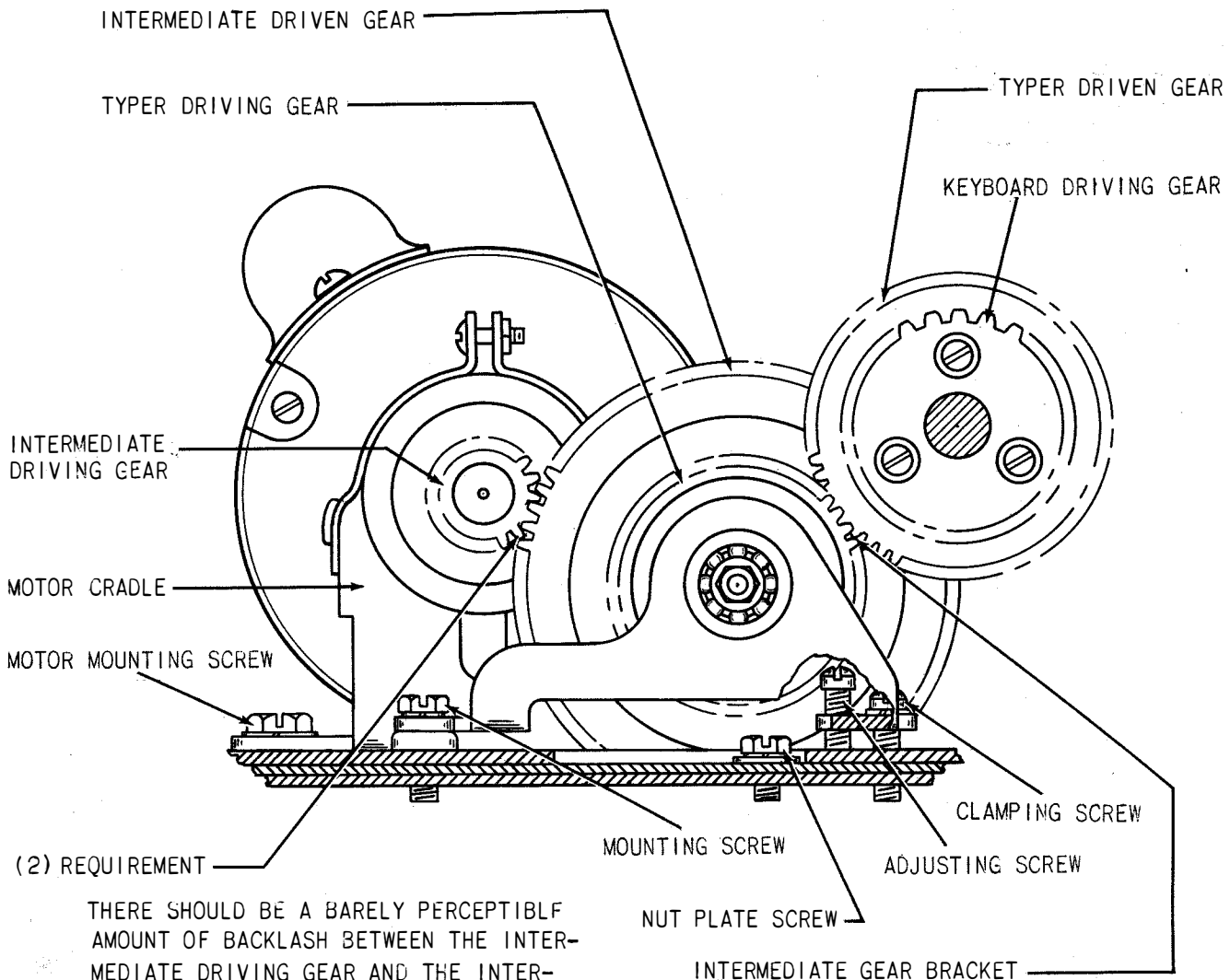


Figure 7-22. Typyter and Signal Generator Gearing



THERE SHOULD BE A BARELY PERCEPTIBLE AMOUNT OF BACKLASH BETWEEN THE INTERMEDIATE DRIVING GEAR AND THE INTERMEDIATE DRIVEN GEAR AT THE POINT WHERE THE BACKLASH IS THE LEAST.

TO ADJUST

RAISE OR LOWER THE FRONT END OF THE INTERMEDIATE GEAR BRACKET BY MEANS OF THE FILISTER HEAD ADJUSTING AND CLAMPING SCREWS LOCATED AT THE FRONT END OF THE BRACKET. REFINE REQUIREMENT (1) IF NECESSARY.

NUT PLATE SCREW

INTERMEDIATE GEAR BRACKET

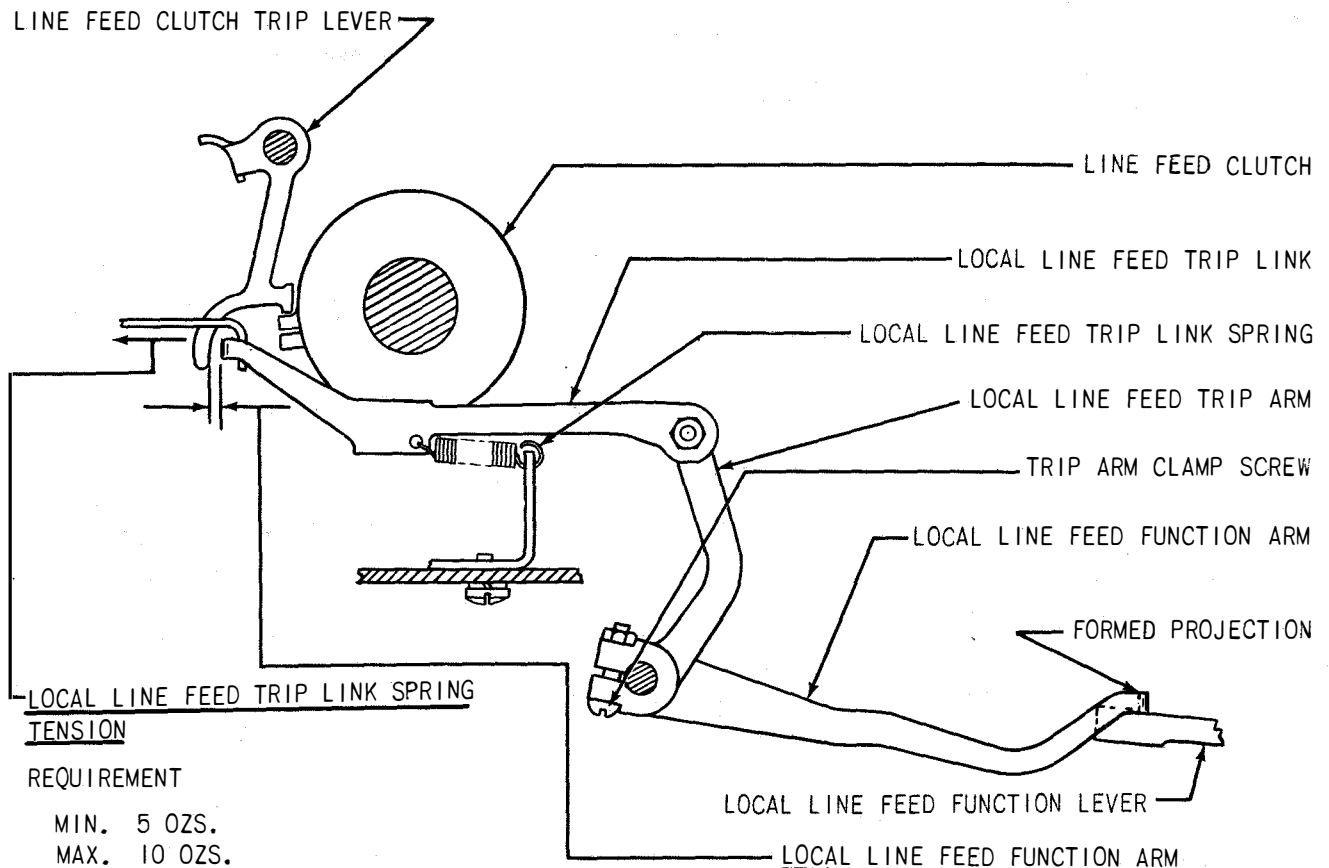
(1) REQUIREMENT

THERE SHOULD BE A BARELY PERCEPTIBLE AMOUNT OF BACKLASH BETWEEN THE TYPER DRIVEN GEAR AND THE TYPER DRIVING GEAR AT THE POINT WHERE BACKLASH IS THE LEAST.

TO ADJUST

POSITION THE COMPLETE INTERMEDIATE GEAR MECHANISM BRACKET BY UTILIZING THE ADJUSTING SLOTS WITH THE THREE HEXAGON HEAD SCREWS' LOOSENED. ALIGN GEARS AT THIS TIME.

Figure 7-23. Keyboard and Motor Gearing



REQUIREMENT

MIN. 5 OZS.  
MAX. 10 OZS.  
TO START THE LINK MOVING.

REQUIREMENT

LINE FEED CLUTCH TRIP LEVER FULLY  
LATCHED.  
SOME CLEARANCE BETWEEN THE LOCAL  
LINE FEED TRIP LINK AND THE LINE  
FEED CLUTCH TRIP LEVER ON THE TYPER.  
MAX. 0.030 INCH

TO ADJUST

FIRST POSITION THE LOCAL LINE FEED  
FUNCTION ARM (WITH ITS CLAMP SCREW  
LOOSENED) TO CENTER ITS FORMED  
PROJECTION ON THE LOCAL LINE FEED  
FUNCTION LEVER AND TIGHTEN CLAMP SCREW.  
THEN POSITION THE LOCAL LINE FEED TRIP  
ARM WITH ITS CLAMP SCREW LOOSENED  
TO PROVIDE SPECIFIED CLEARANCE.

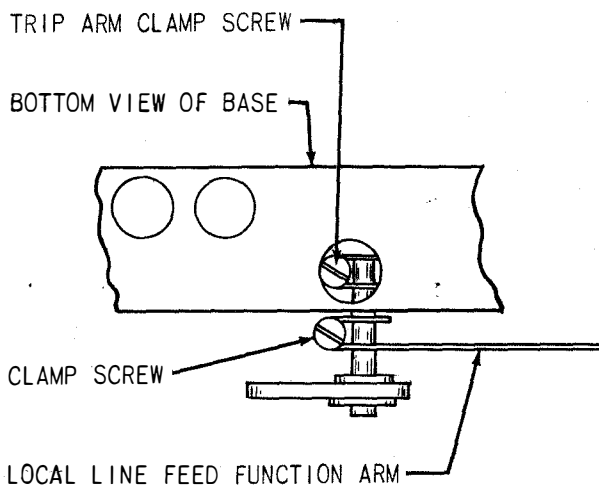
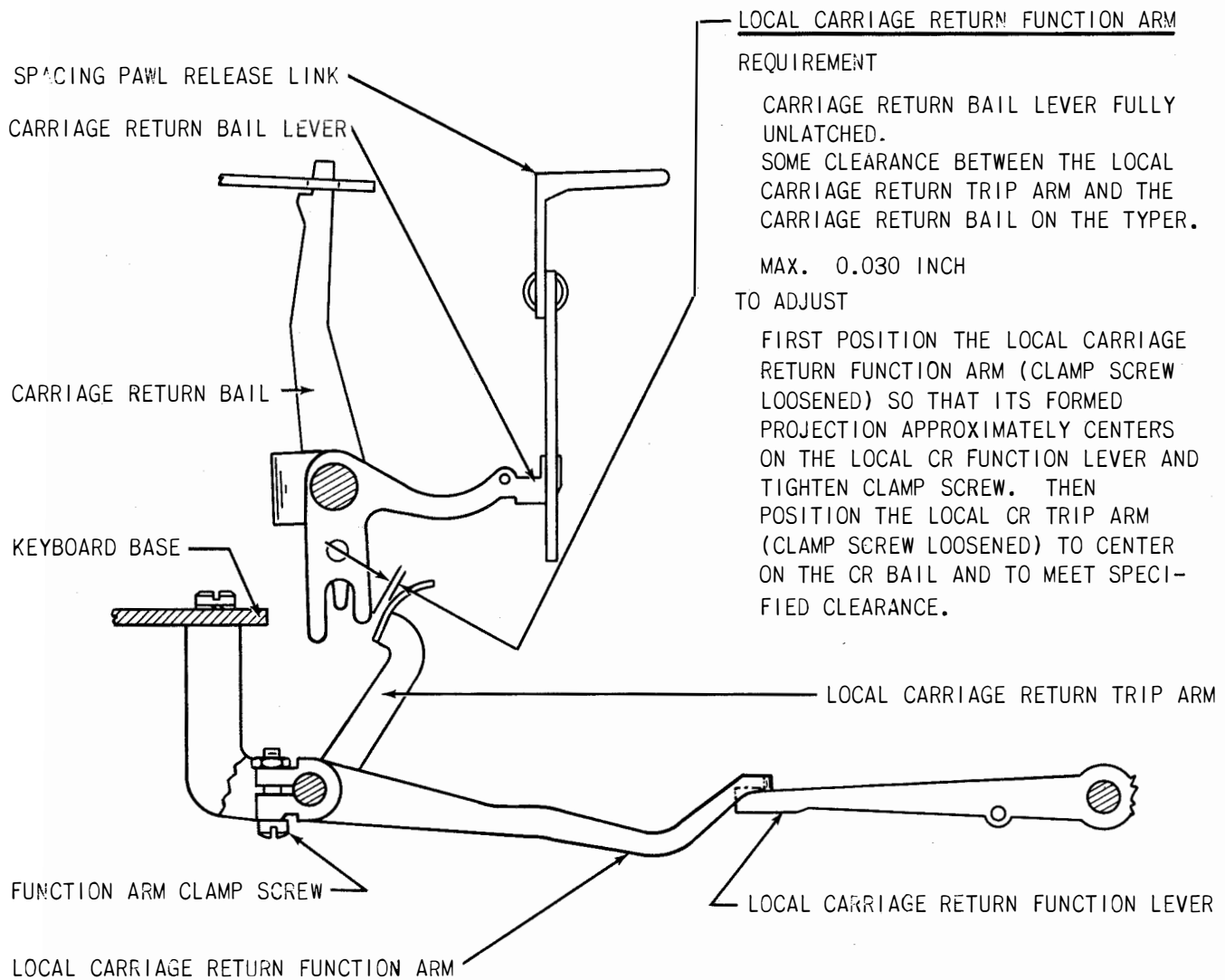


Figure 7-24. Keyboard, Local Line Feed Mechanism



**Figure 7-25. Keyboard, Local Carriage Return Mechanism**



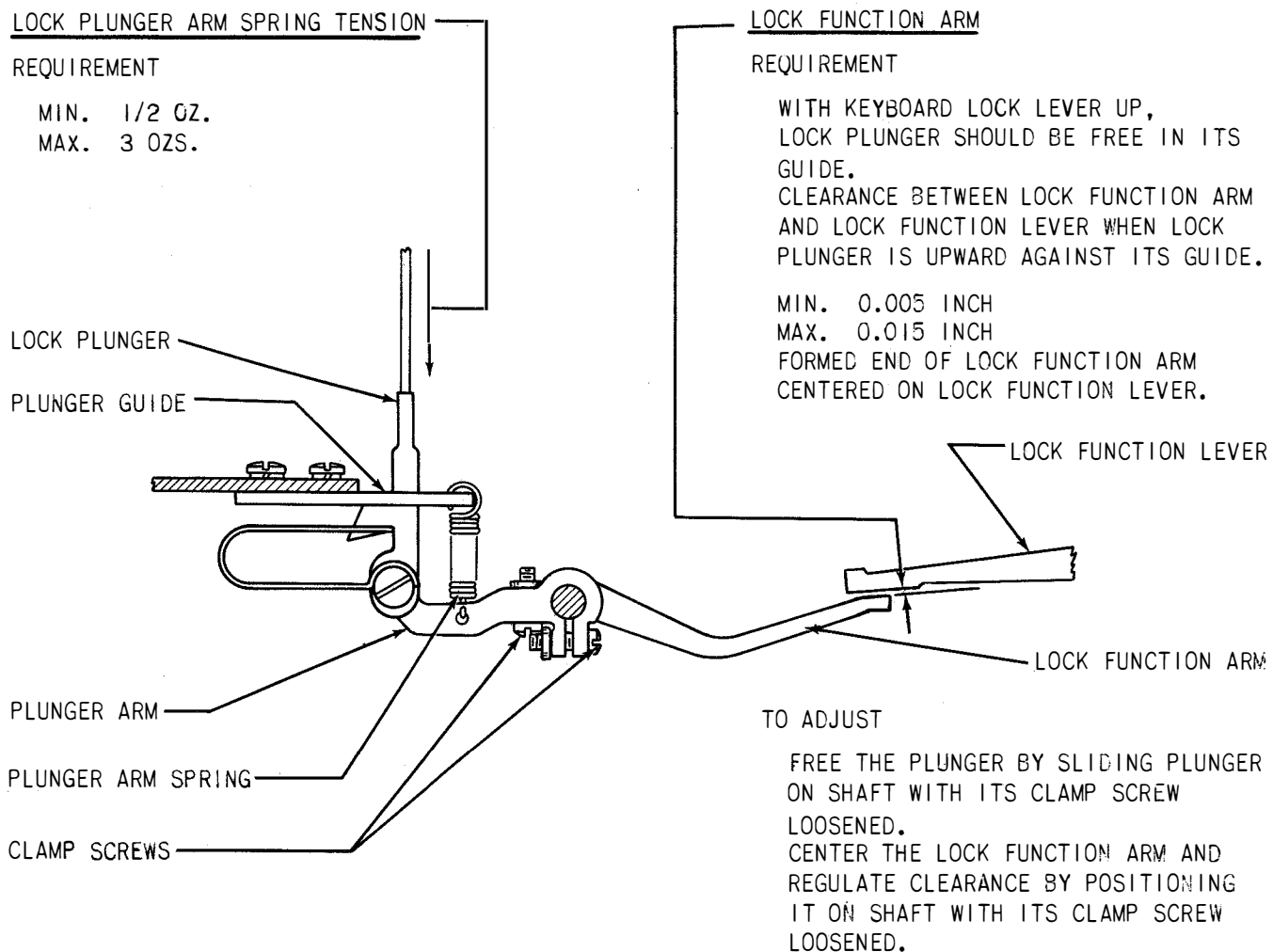
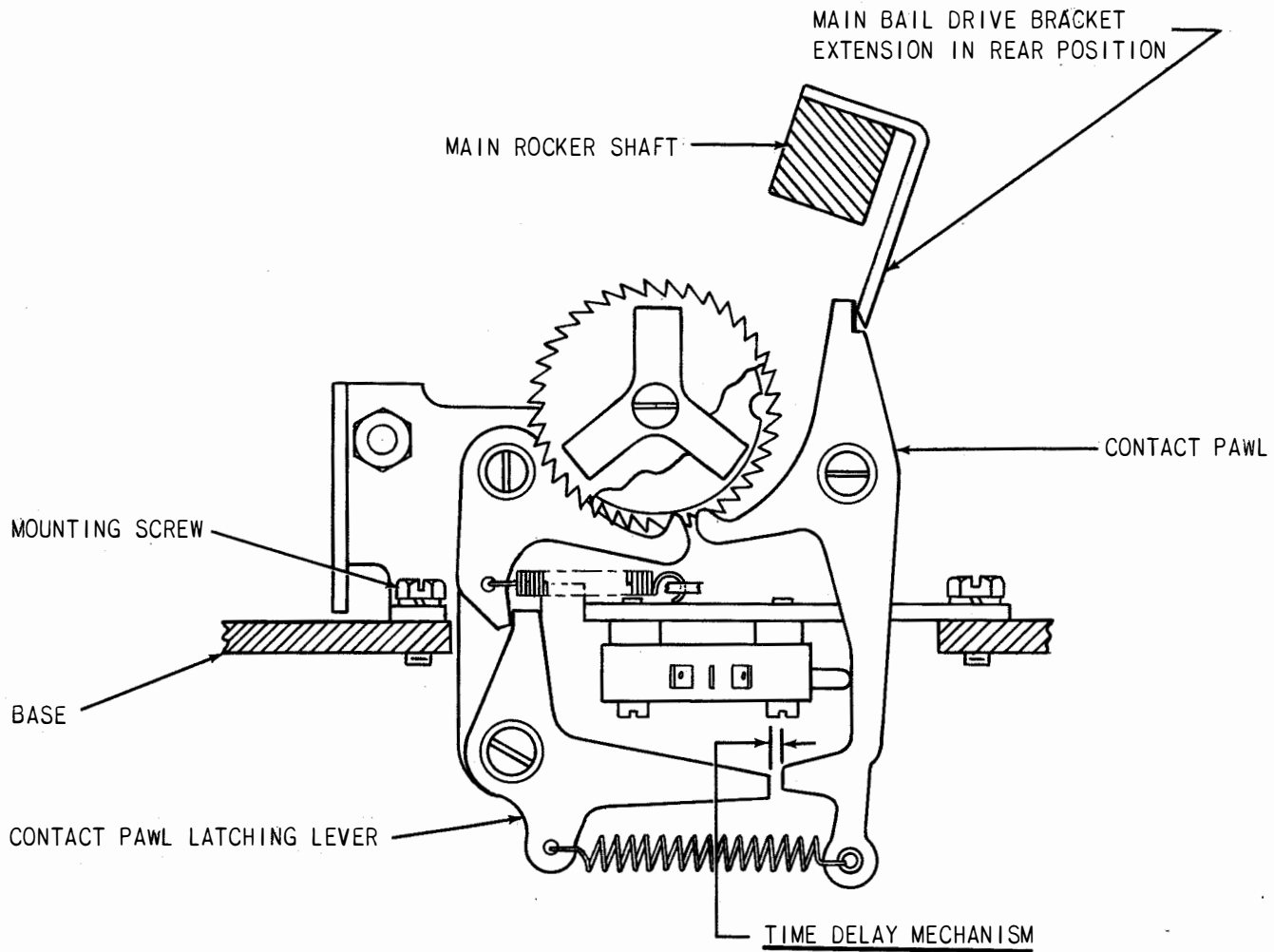


Figure 7-26. Keyboard Lock Mechanism

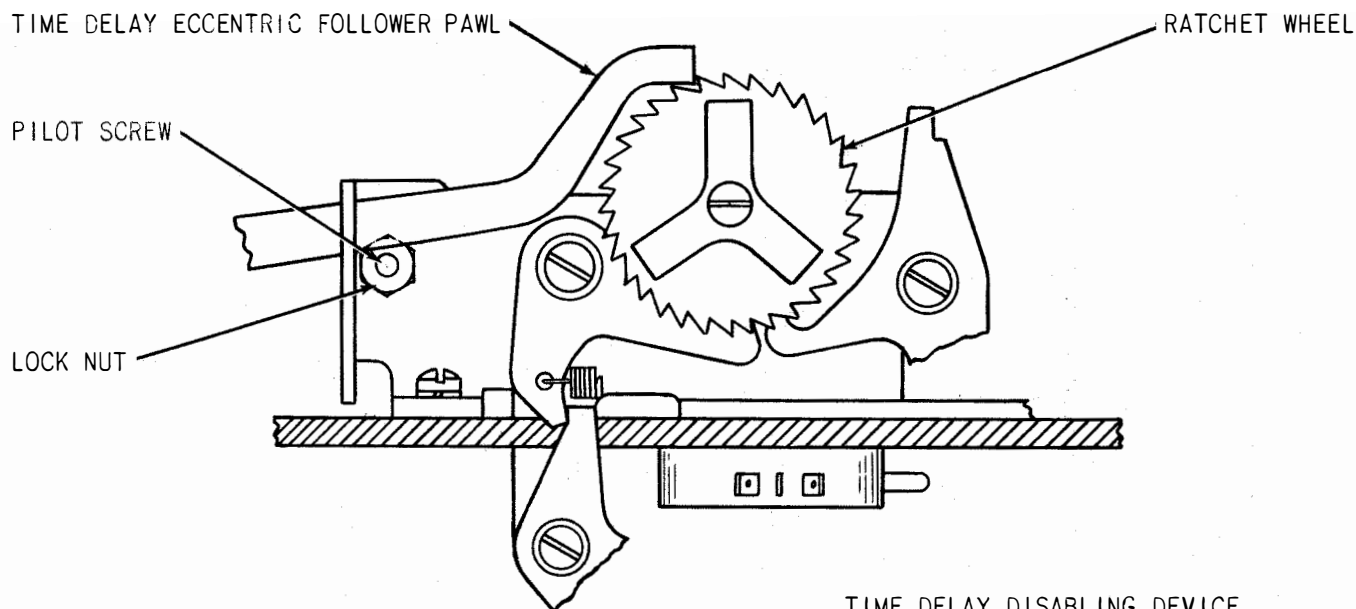


REQUIREMENT

TYPED ON KEYBOARD.  
 DRIVE BRACKET EXTENSION IN REAR  
 POSITION.  
 SOME CLEARANCE BETWEEN CONTACT  
 PAWL AND CONTACT PAWL LATCHING LEVER.  
 MIN. 0.020 INCH  
 MAX. 0.050 INCH  
 TO ADJUST

REMOVE THE TYPED FROM THE KEYBOARD  
 AND POSITION THE TIME DELAY  
 MECHANISM WITH ITS MOUNTING SCREWS  
 LOOSENED.

**Figure 7-27. Keyboard, Time Delay Mechanism**



TIME DELAY DISABLING DEVICE

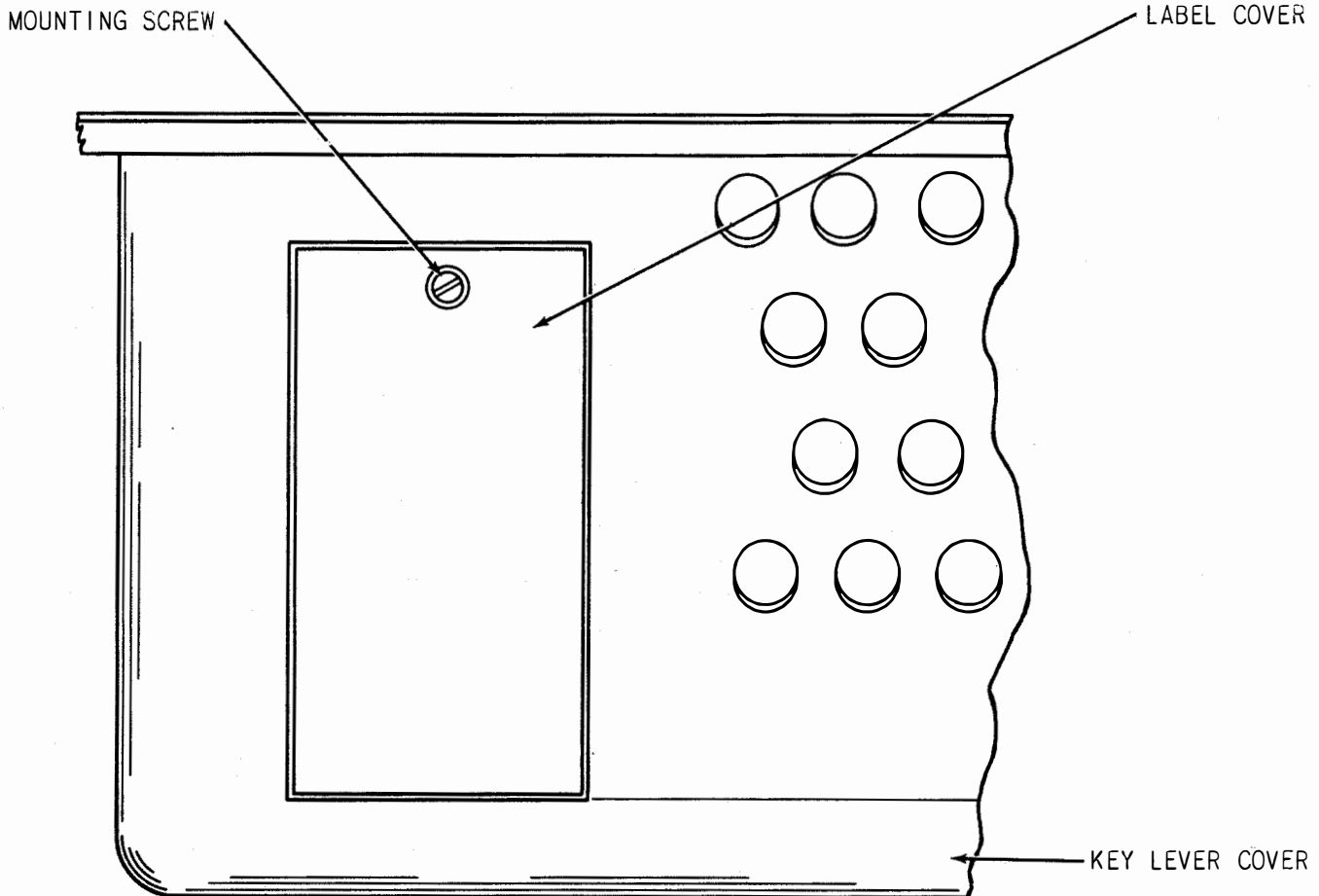
REQUIREMENT

DISABLE THE TIME DELAY MECHANISM  
WHEN NOT REQUIRED.

TO ADJUST

RAISE THE PILOT SCREW (LOCK NUT  
LOOSENED) AND ECCENTRIC FOLLOWER  
PAWL UNTIL THE PAWL CLEARS THE  
RATCHET WHEEL.

**Figure 7-28. Keyboard, Time Delay Disabling Device**



LABEL COVER (PLASTIC COVER)

REQUIREMENT

THE PLASTIC COVER SHOULD BE FULLY SEATED IN POSITION BEFORE TIGHTENING THE MOUNTING SCREW.

TO ADJUST

POSITION THE LABEL COVER WITH THE MOUNTING SCREW LOOSENED.

**Figure 7-29. Keyboard, Label Cover, Plastic Window**

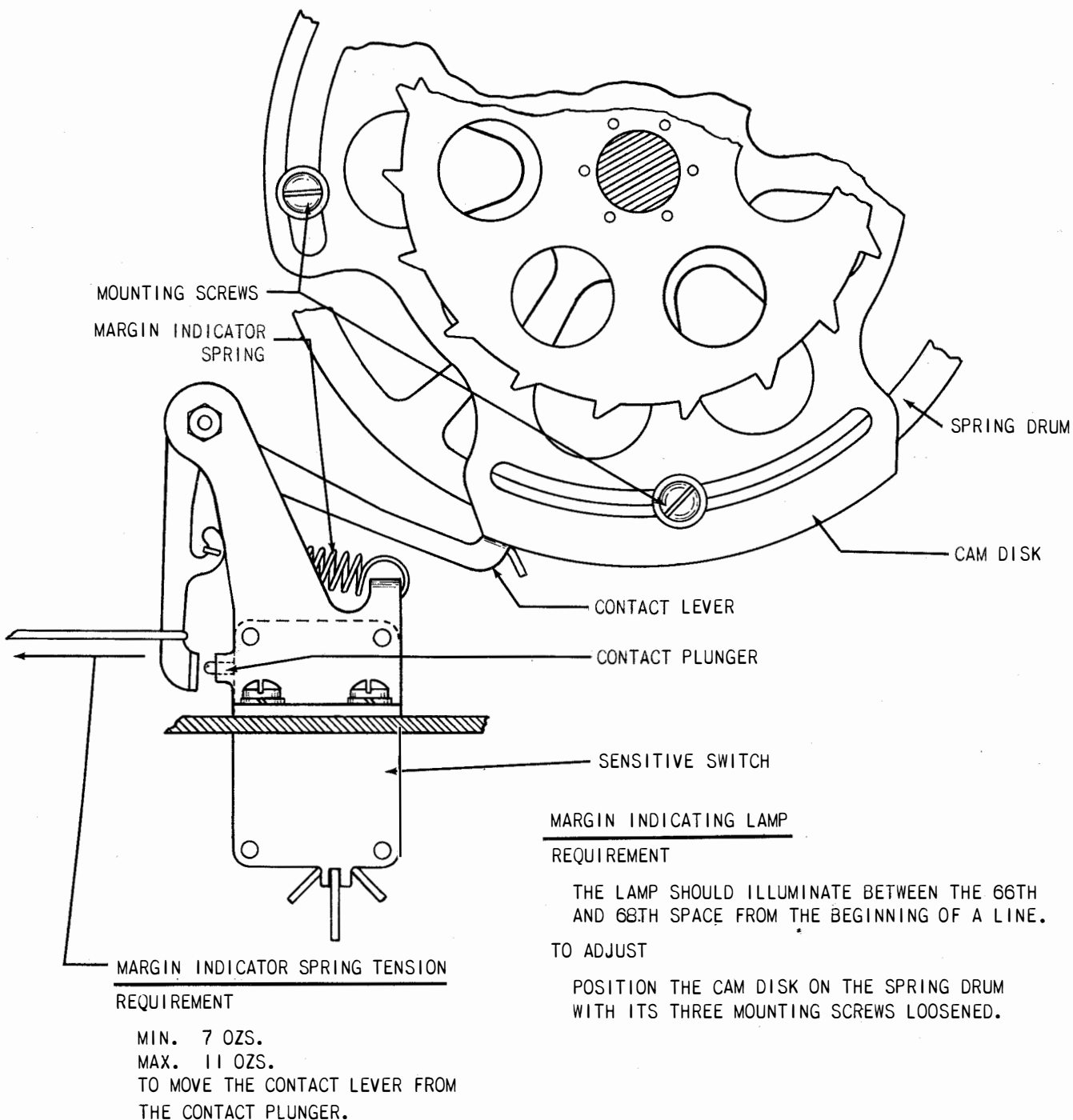
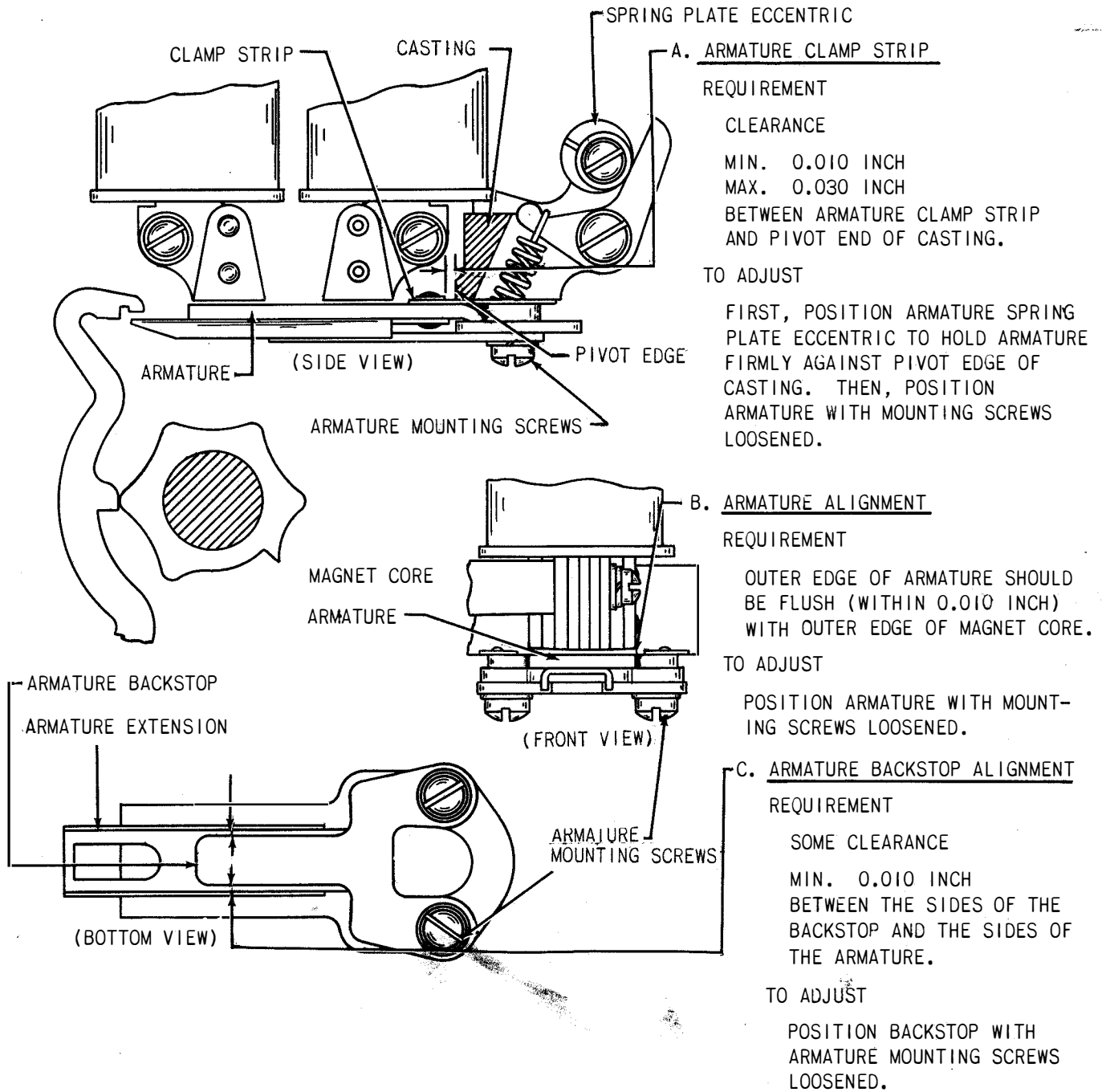


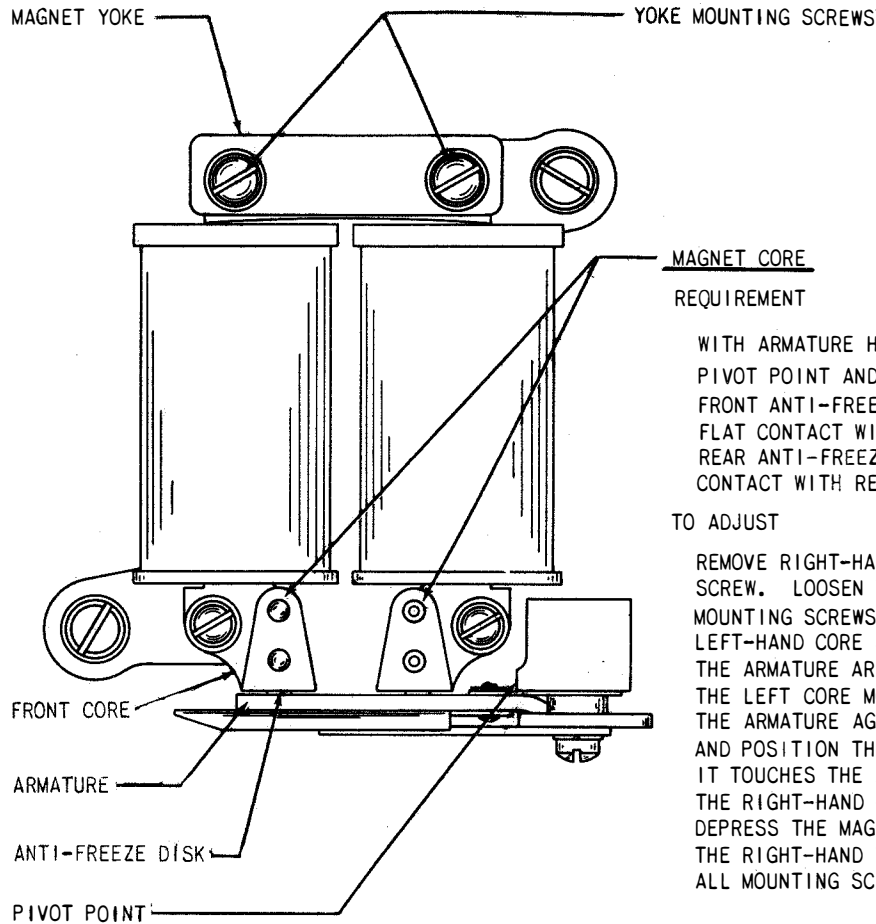
Figure 7-30. Keyboard, Margin Indicating Mechanism

**d. AUTOMATIC TYPER MX-1115/UG.**

NOTE  
TO FACILITATE MAKING THE FOLLOWING ADJUSTMENTS, REMOVE THE  
SELECTOR MAGNET ASSEMBLY. SEE PARAGRAPH 3 a. (14)



**Figure 7-31. Automatic Typewriter, Selector Magnet**



**REQUIREMENT**

WITH ARMATURE HELD FIRMLY AGAINST PIVOT POINT AND FRONT CORE, THE FRONT ANTI-FREEZE DISK SHOULD MAKE FLAT CONTACT WITH FRONT CORE AND REAR ANTI-FREEZE DISK SHOULD MAKE CONTACT WITH REAR CORE.

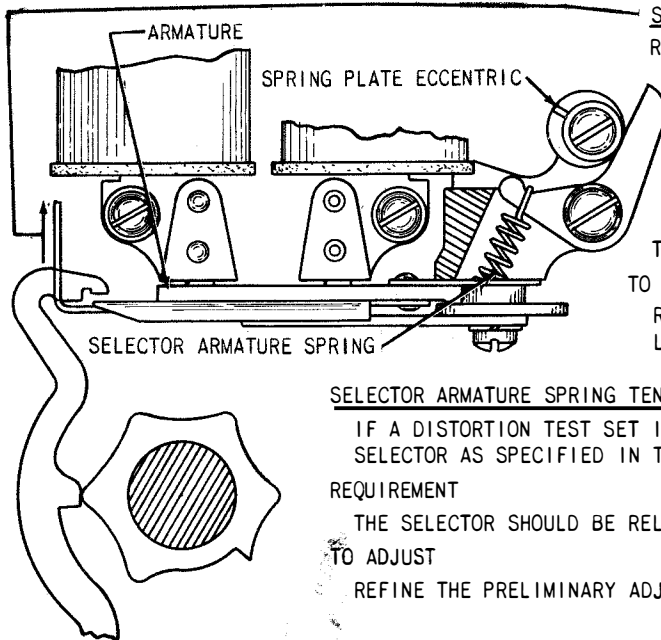
**TO ADJUST**

REMOVE RIGHT-HAND YOKE MOUNTING SCREW. LOOSEN THE OTHER THREE MOUNTING SCREWS AND POSITION THE LEFT-HAND CORE SO THAT ITS FACE AND THE ARMATURE ARE PARALLEL. TIGHTEN THE LEFT CORE MOUNTING SCREW. HOLD THE ARMATURE AGAINST THE LEFT CORE AND POSITION THE RIGHT CORE SO THAT IT TOUCHES THE ARMATURE AND TIGHTEN THE RIGHT-HAND CORE MOUNTING SCREW. DEPRESS THE MAGNET YOKE AND REPLACE THE RIGHT-HAND YOKE SCREW. TIGHTEN ALL MOUNTING SCREWS.

**NOTE**

REPLACE THE SELECTOR MAGNET ASSEMBLY.

**Figure 7-32. Automatic Typewriter, Selector Magnet**



**SELECTOR ARMATURE SPRING TENSION - PRELIMINARY REQUIREMENT**

BOTH THE MARKING AND SPACING LOCK LEVERS (FIG. 33) ON HIGH PART OF LOCK LEVER CAM. SCALE APPLIED UPWARD AT END OF ARMATURE.

	<u>0.060 AMP.</u>	<u>0.020 AMP.</u>
TENSION: MIN.	2-1/2 OZS.	MIN. 1-1/2 OZS.
	MAX. 3 OZS.	MAX. 2 OZS.

TO PULL ARMATURE TO MARKING POSITION.

**TO ADJUST**

ROTATE SPRING PLATE ECCENTRIC WITH ITS MOUNTING SCREW LOOSENED.

**SELECTOR ARMATURE SPRING TENSION - FINAL**

IF A DISTORTION TEST SET IS AVAILABLE, DETERMINE THE INTERNAL BIAS OF THE SELECTOR AS SPECIFIED IN THE INSTRUCTIONS FURNISHED WITH THE SET.

**REQUIREMENT**

THE SELECTOR SHOULD BE RELATIVELY FREE OF INTERNAL BIAS.

**TO ADJUST**

REFINE THE PRELIMINARY ADJUSTMENT BY ROTATING THE SPRING PLATE ECCENTRIC.

**Figure 7-32A. Automatic Typewriter, Selector Magnet**

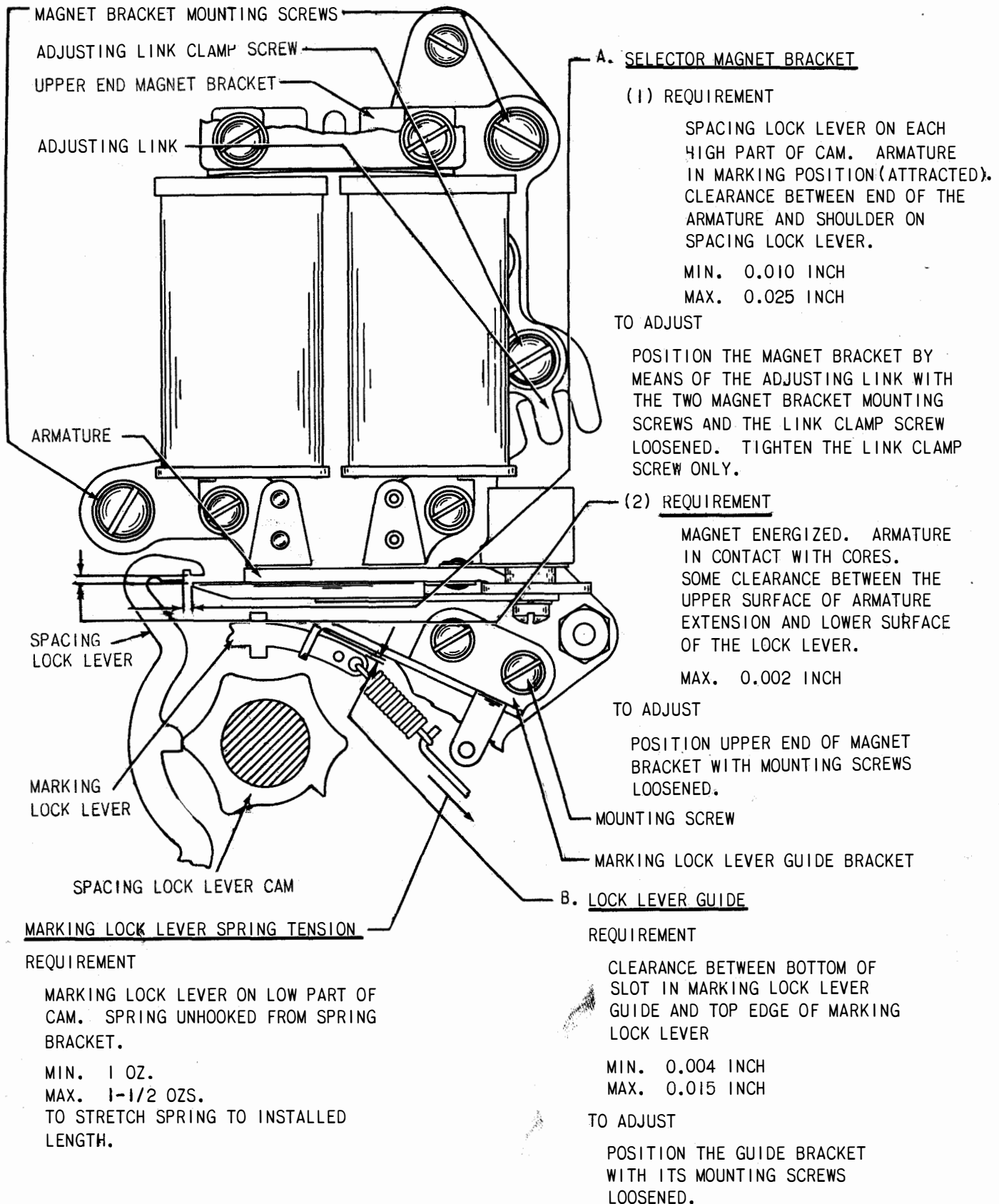
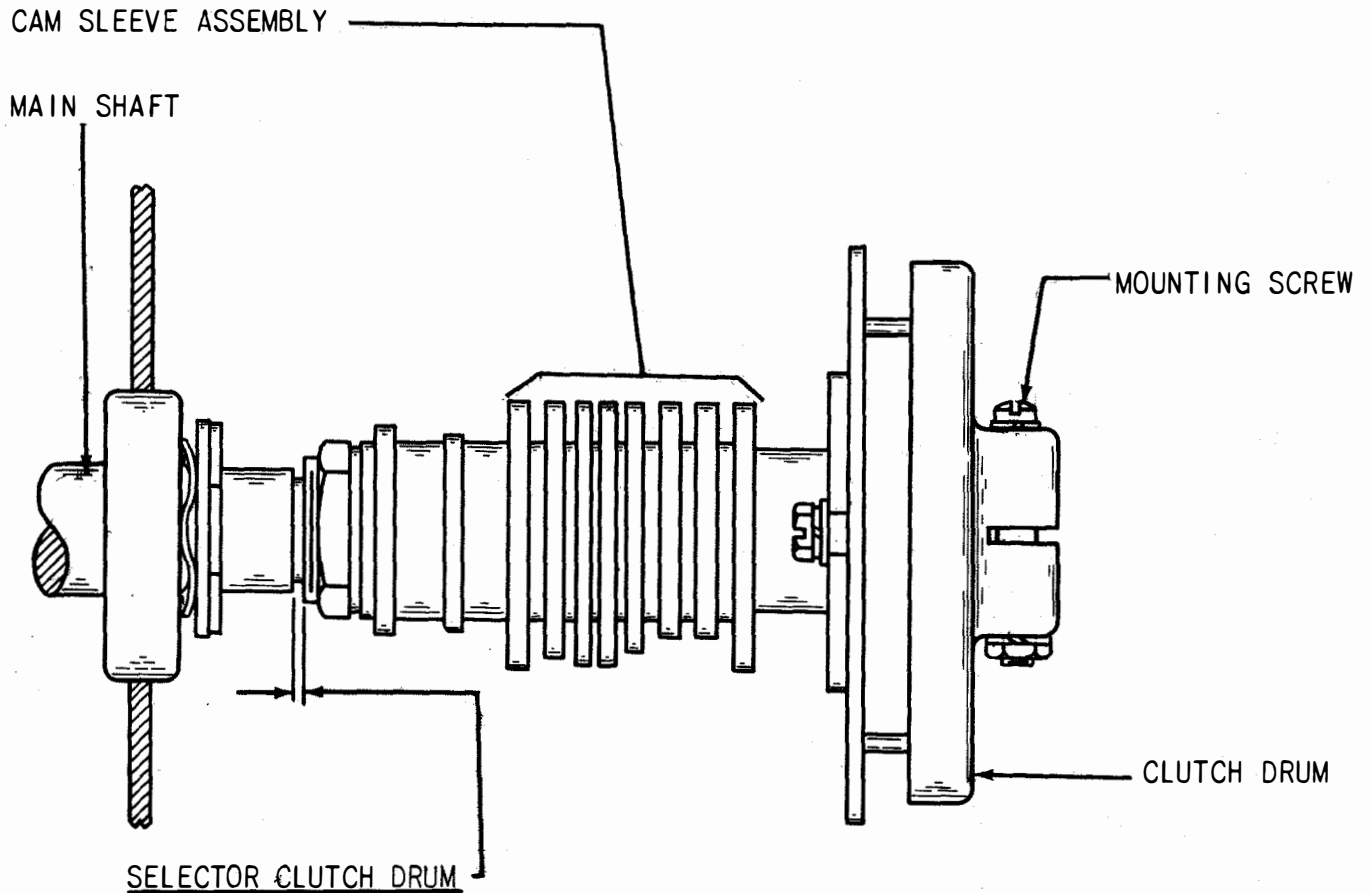


Figure 7-33. Automatic Typewriter, Selector Mechanism





REQUIREMENT

SELECTOR CLUTCH DISENGAGED, CAM SLEEVE  
ASSEMBLY SHOULD HAVE SOME END PLAY.

MAX. 0.008 INCH

TO CHECK

HOLD CLUTCH DISENGAGED WITH FINGER AND THUMB AND  
NOTE END PLAY AT CLUTCH MEMBER BY ALTERNATELY  
PUSHING AND PULLING WITH SAME FINGERS.

TO ADJUST

UTILIZE CLEARANCE IN CLUTCH DRUM MOUNTING HOLE  
WITH SCREW LOOSENED.

**Figure 7-34. Automatic Typewriter, Selector Cam-Clutch**

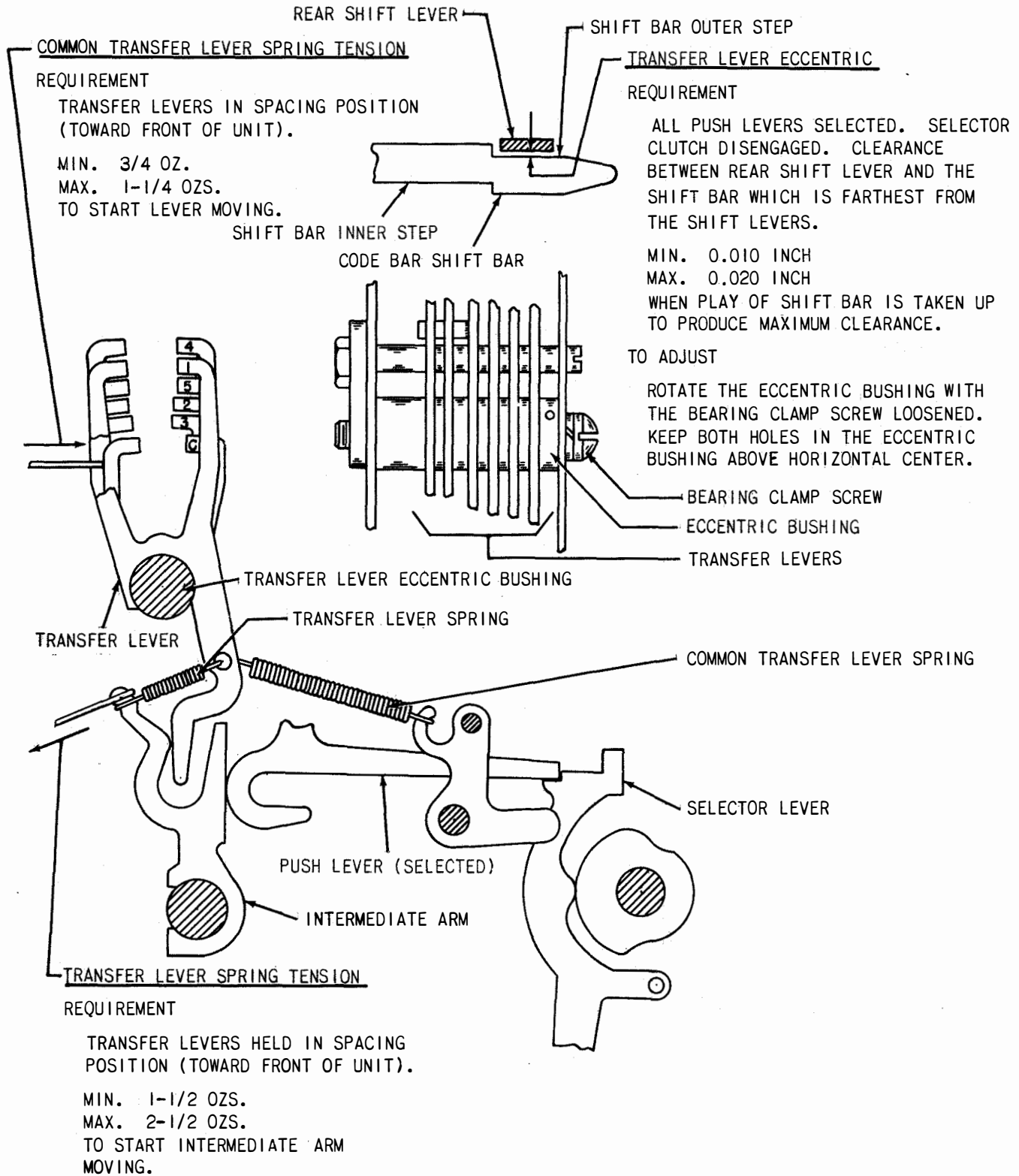
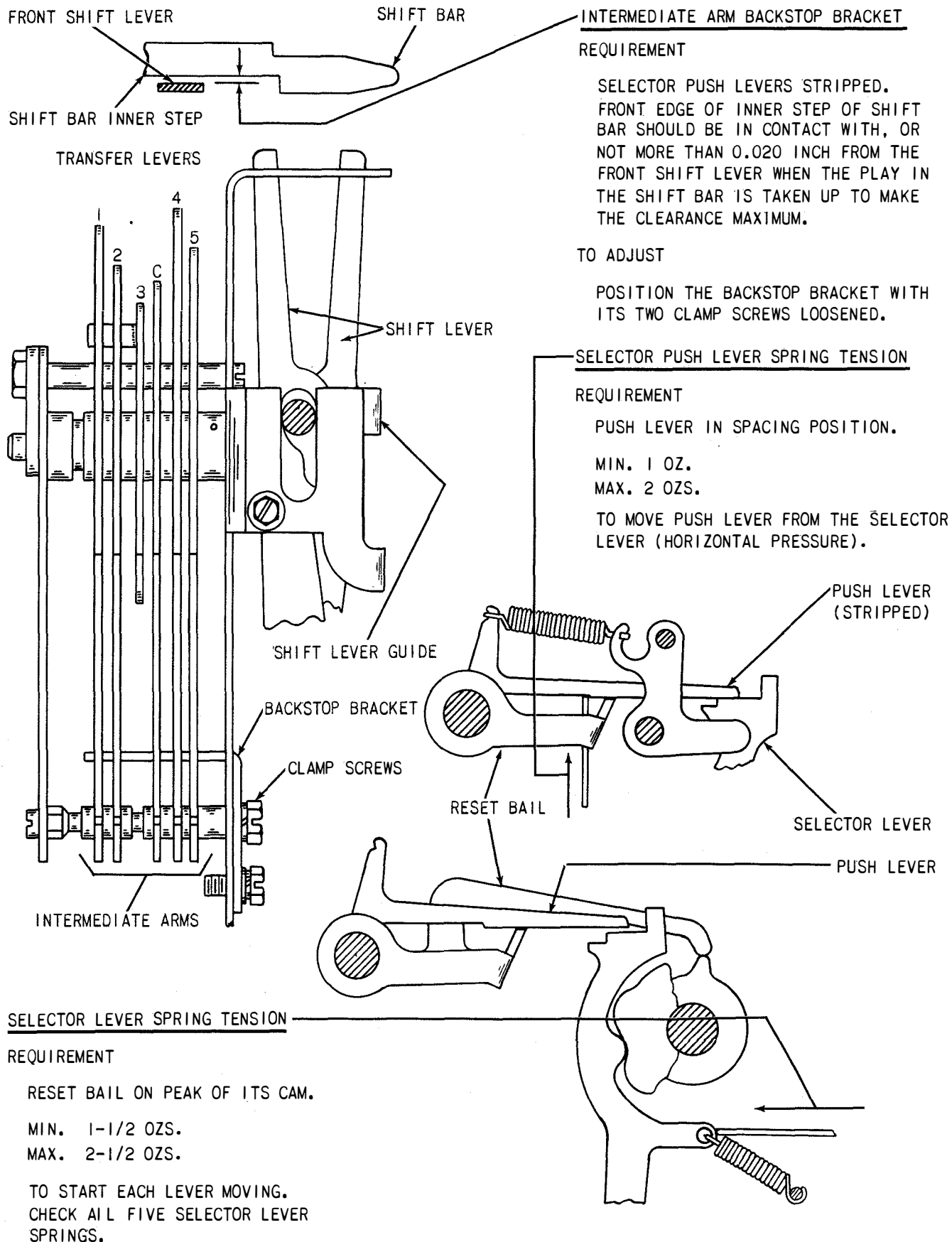


Figure 7-35. Automatic Typewriter, Transfer Mechanism



**Figure 7-36. Automatic Typewriter, Code Bar Shift Mechanism**

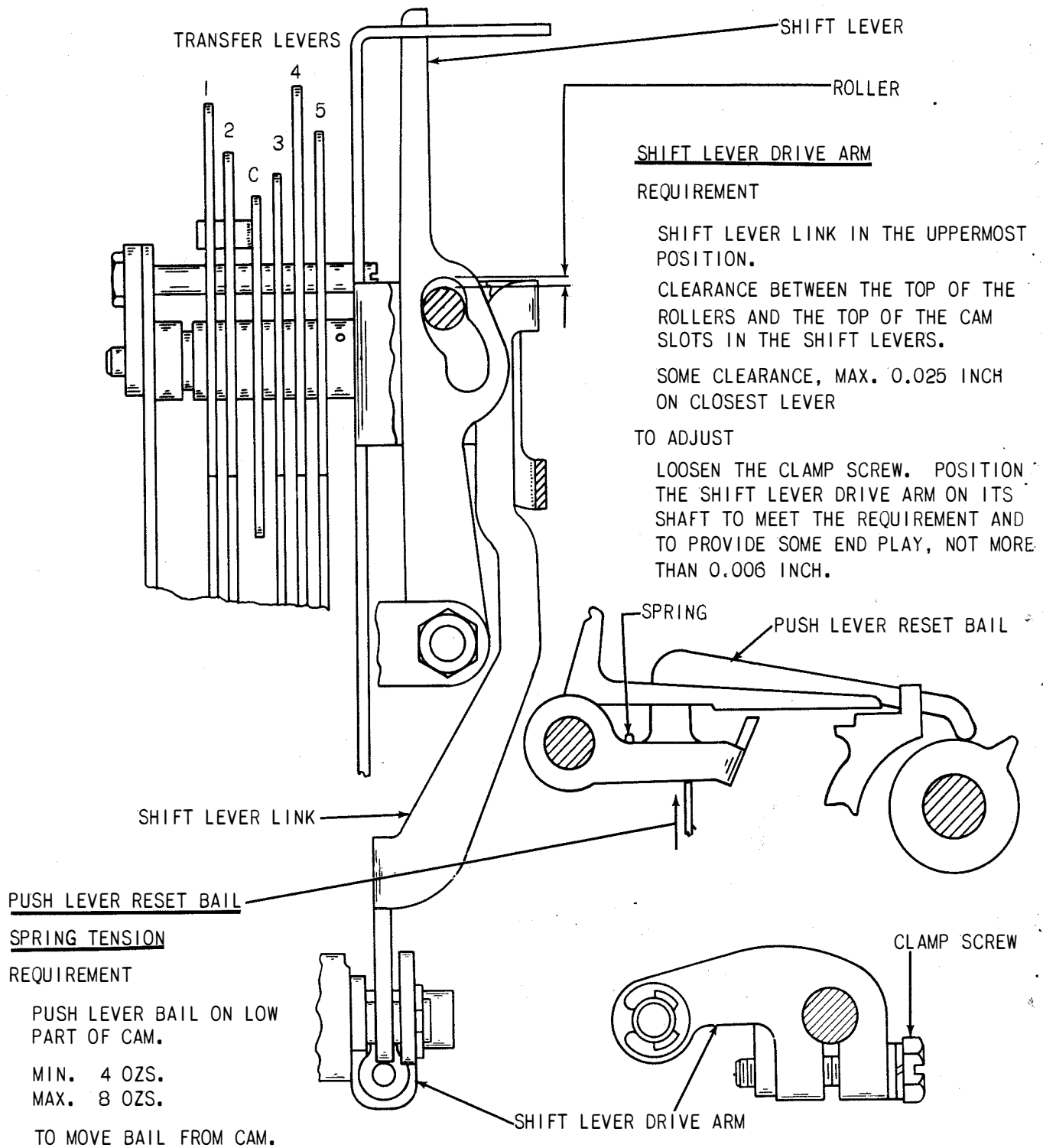


Figure 7-37. Automatic Typewriter, Code Bar Shift Mechanism

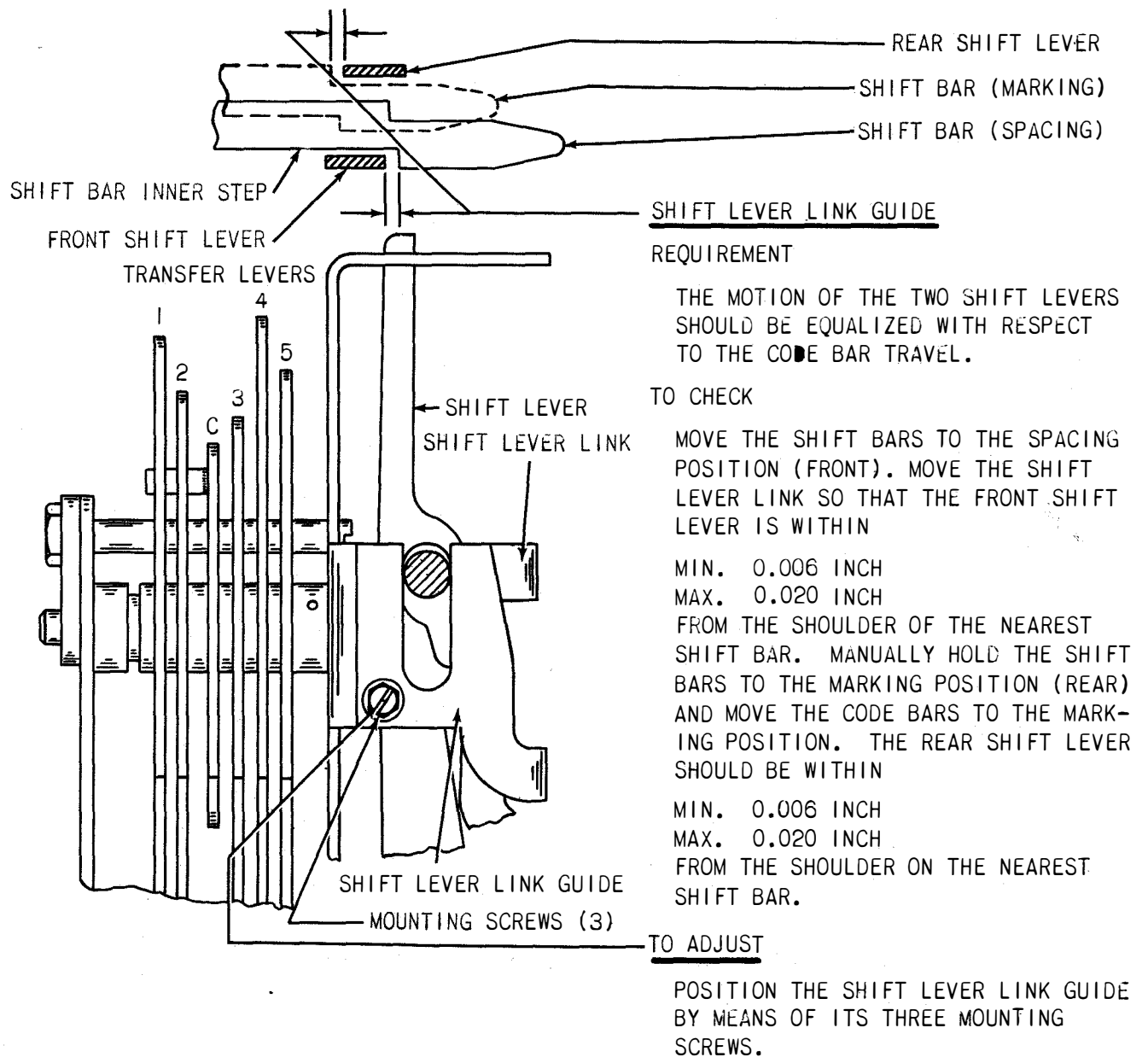


Figure 7-38. Automatic Typewriter, Code Bar Shift Mechanism

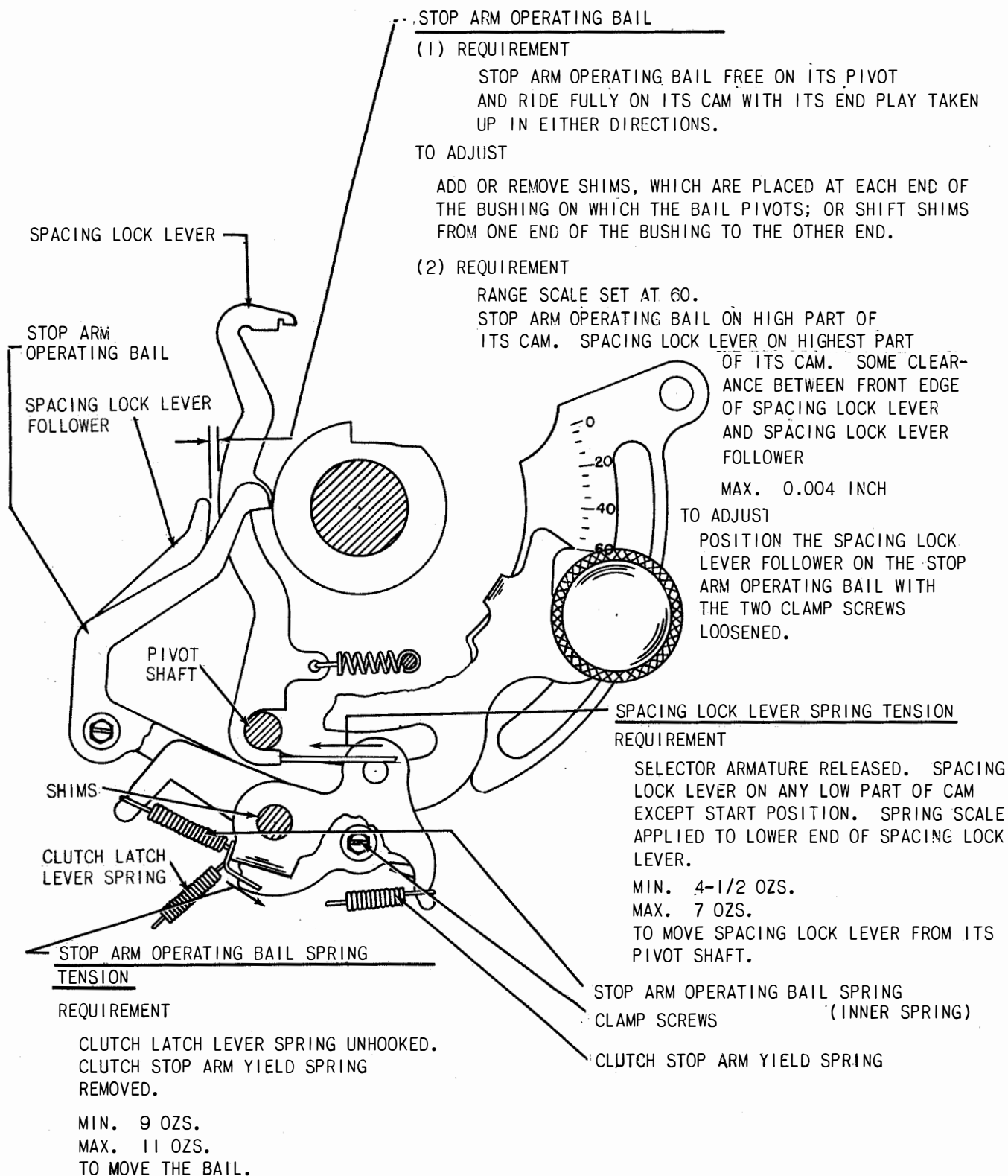
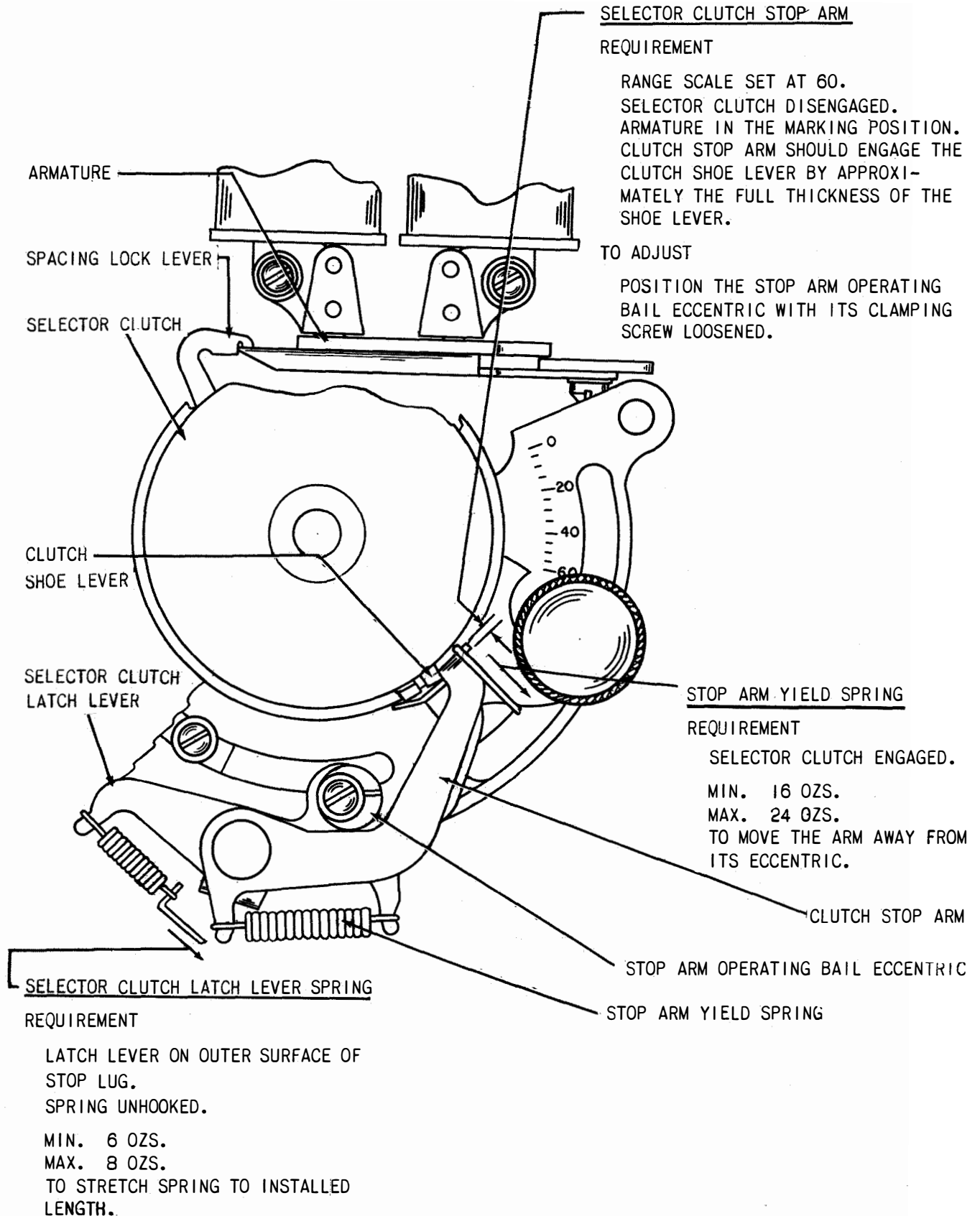
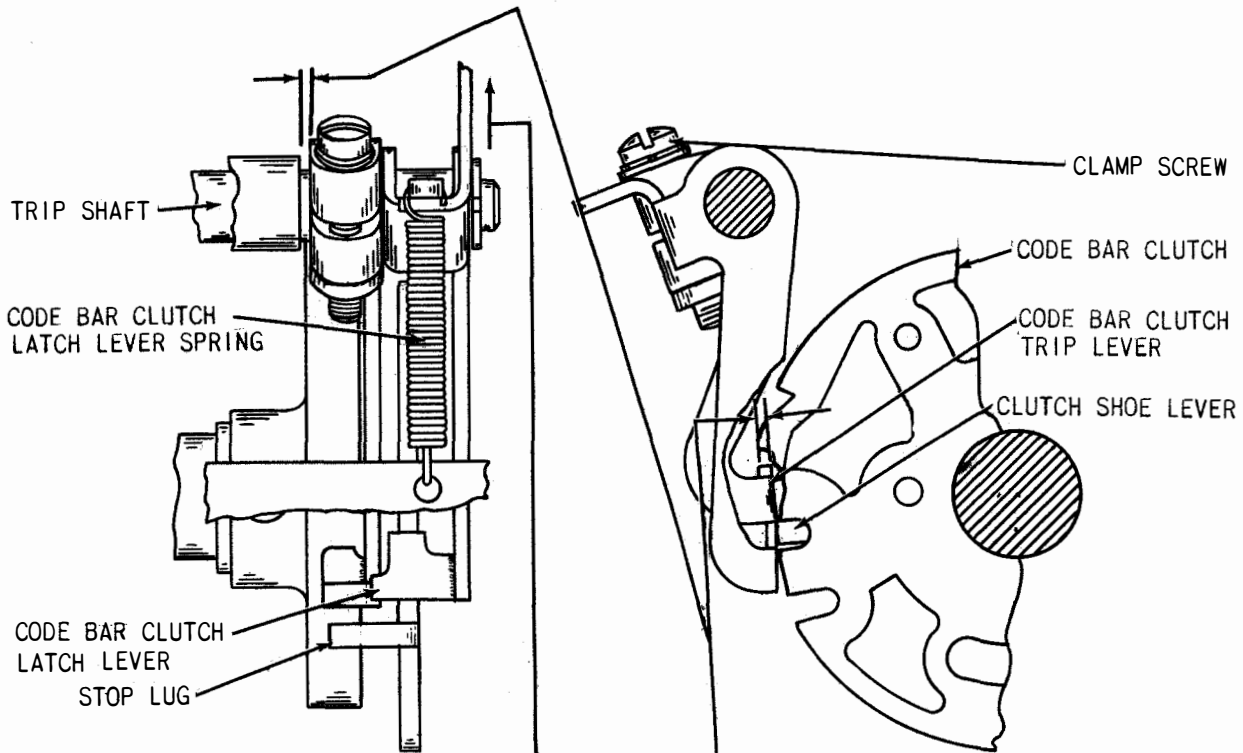


Figure 7-39. Automatic Typewriter, Selector Clutch Stop Arm Operating Bail



**Figure 7-40. Automatic Typewriter, Selector Clutch Mechanism**



CODE BAR CLUTCH LATCH LEVER SPRING TENSION  
REQUIREMENT

CLUTCH TURNED TO STOP POSITION BUT WITH LATCH LEVER NOT LATCHED.

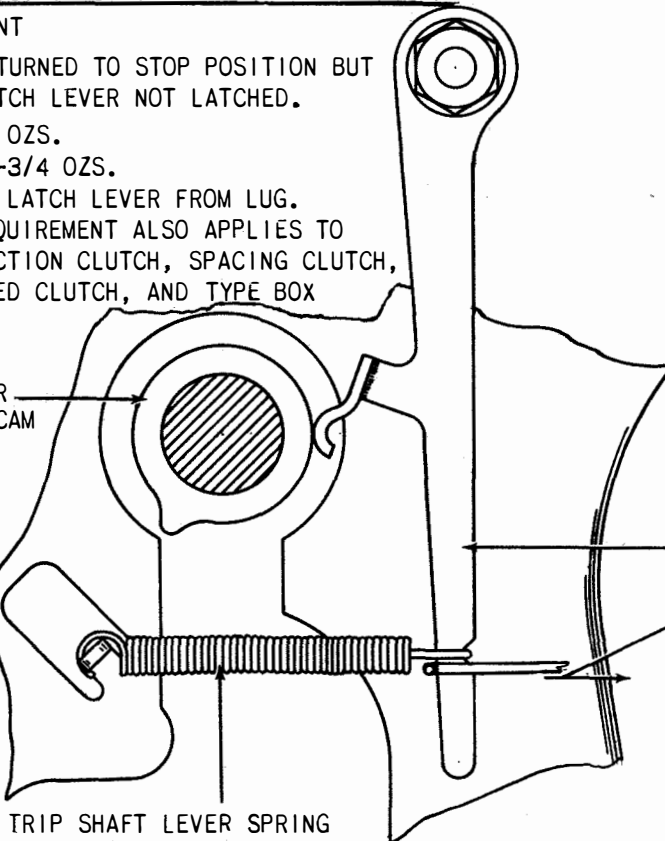
MIN. 5 OZS.

MAX. 6-3/4 OZS.

TO MOVE LATCH LEVER FROM LUG.

THIS REQUIREMENT ALSO APPLIES TO THE FUNCTION CLUTCH, SPACING CLUTCH, LINE FEED CLUTCH, AND TYPE BOX CLUTCH.

SELECTOR  
CLUTCH CAM



TRIP SHAFT LEVER SPRING

CODE BAR CLUTCH TRIP LEVER ADJUSTMENT  
REQUIREMENT

REQUIREMENT

SELECTOR CLUTCH AND CODE BAR CLUTCH IN STOP POSITIONS. CODE BAR CLUTCH TRIP LEVER SHOULD ENGAGE THE CLUTCH SHOE LEVER BY THE FULL THICKNESS OF THE SHOE LEVER.

TO ADJUST

POSITION THE TRIP LEVER ON ITS SHAFT WITH ITS CLAMP SCREW LOOSENED.

PROVIDE SOME END PLAY OF THE TRIP LEVER SHAFT.

MAX. 0.006 INCH

TRIP SHAFT LEVER

TRIP SHAFT LEVER SPRING TENSION  
REQUIREMENT

REQUIREMENT

TRIP SHAFT LEVER ON LOW PART OF CAM. CODE BAR CLUTCH ENGAGED. ROTATE 1/4 TURN.

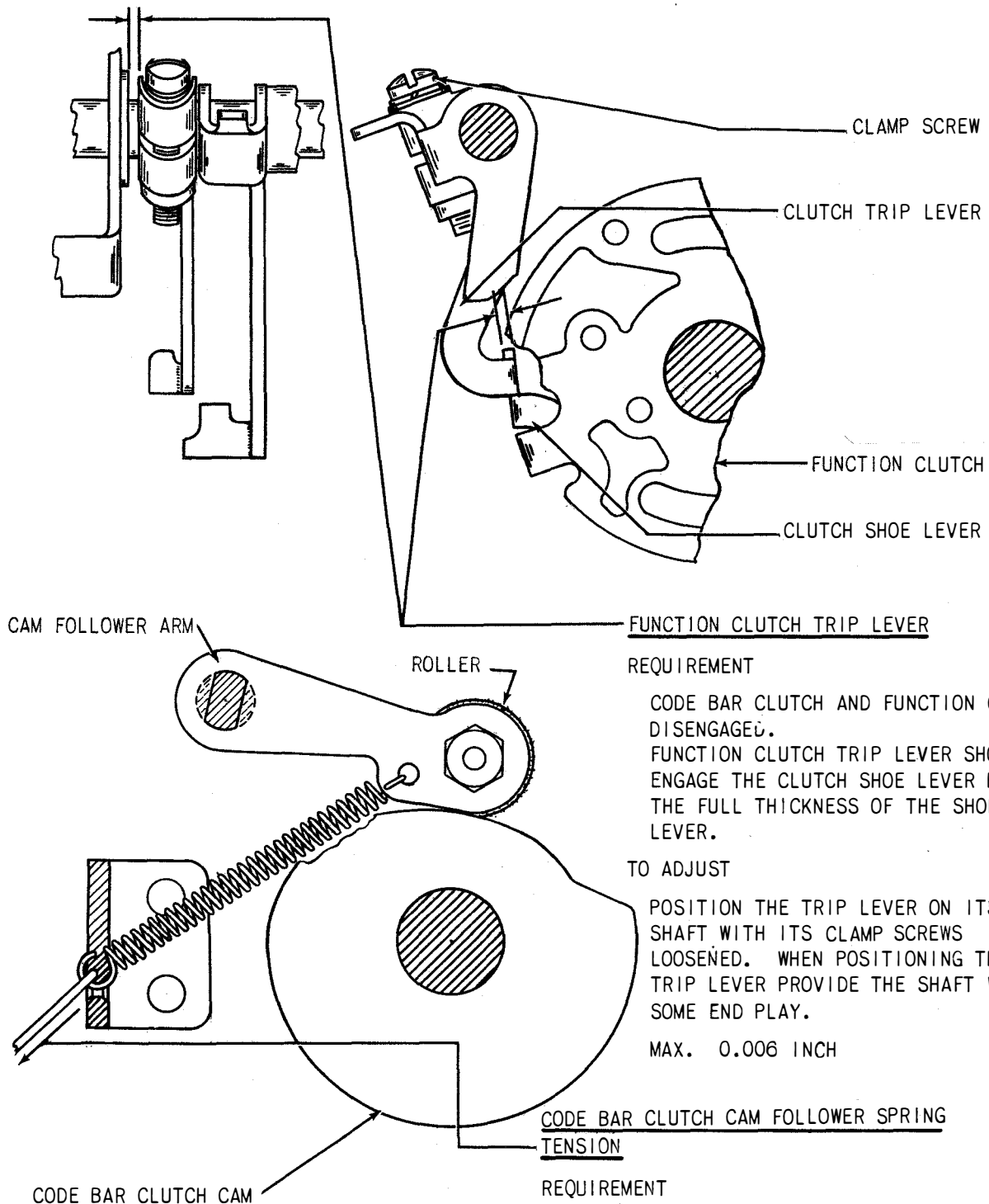
MIN. 1 OZ.

MAX. 2 OZS.

TO START LEVER MOVING.

Figure 7-41. Automatic Typewriter, Code Bar Clutch Trip Shaft Mechanism





REQUIREMENT

CODE BAR CLUTCH AND FUNCTION CLUTCH  
DISENGAGED.  
FUNCTION CLUTCH TRIP LEVER SHOULD  
ENGAGE THE CLUTCH SHOE LEVER BY  
THE FULL THICKNESS OF THE SHOE  
LEVER.

TO ADJUST

POSITION THE TRIP LEVER ON ITS  
SHAFT WITH ITS CLAMP SCREWS  
LOOSENED. WHEN POSITIONING THE  
TRIP LEVER PROVIDE THE SHAFT WITH  
SOME END PLAY.

MAX. 0.006 INCH

CODE BAR CLUTCH CAM FOLLOWER SPRING  
TENSION

REQUIREMENT

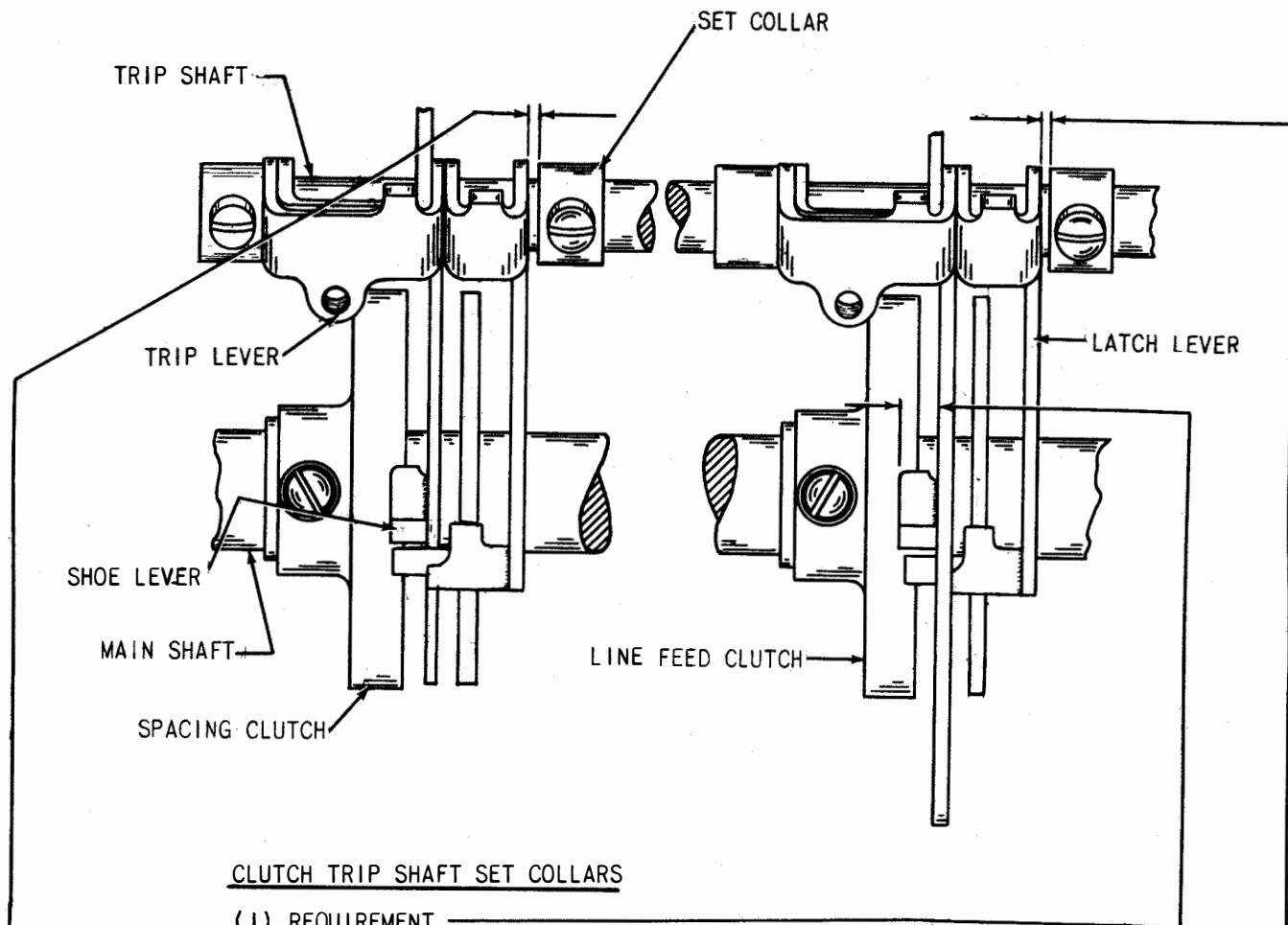
CAM FOLLOWER ROLLER ON THE LOW  
PART OF CAM.  
THE SPRING UNHOOKED FROM SPRING  
BRACKET.

MIN. 20 OZS.

MAX. 24 OZS.

TO PULL SPRING TO INSTALLED LENGTH.

Figure 7-42. Automatic Typewriter, Function Clutch Mechanism

CLUTCH TRIP SHAFT SET COLLARS

## (1) REQUIREMENT

APPROXIMATE ALIGNMENT OF RIGHT ENDS OF STOP EXTENSIONS  
ON TRIP LEVER AND SHOE LEVER.

TO ADJUST

POSITION THE TRIP LEVER SET COLLAR.

## (2) REQUIREMENT

THE SPACING CLUTCH LATCH LEVER SHOULD HAVE SOME SIDE PLAY.

MAX. 0.008 INCH

TO ADJUST

POSITION THE LATCH LEVER SET COLLAR.

## (3) REQUIREMENT

POSITION THE TRIP LEVER SET COLLAR SO THAT THE TRIP  
LEVER HAS SOME PLAY.

MAX. 0.008 INCH

**Figure 7-43. Automatic Typewriter, Trip Shaft Mechanism**

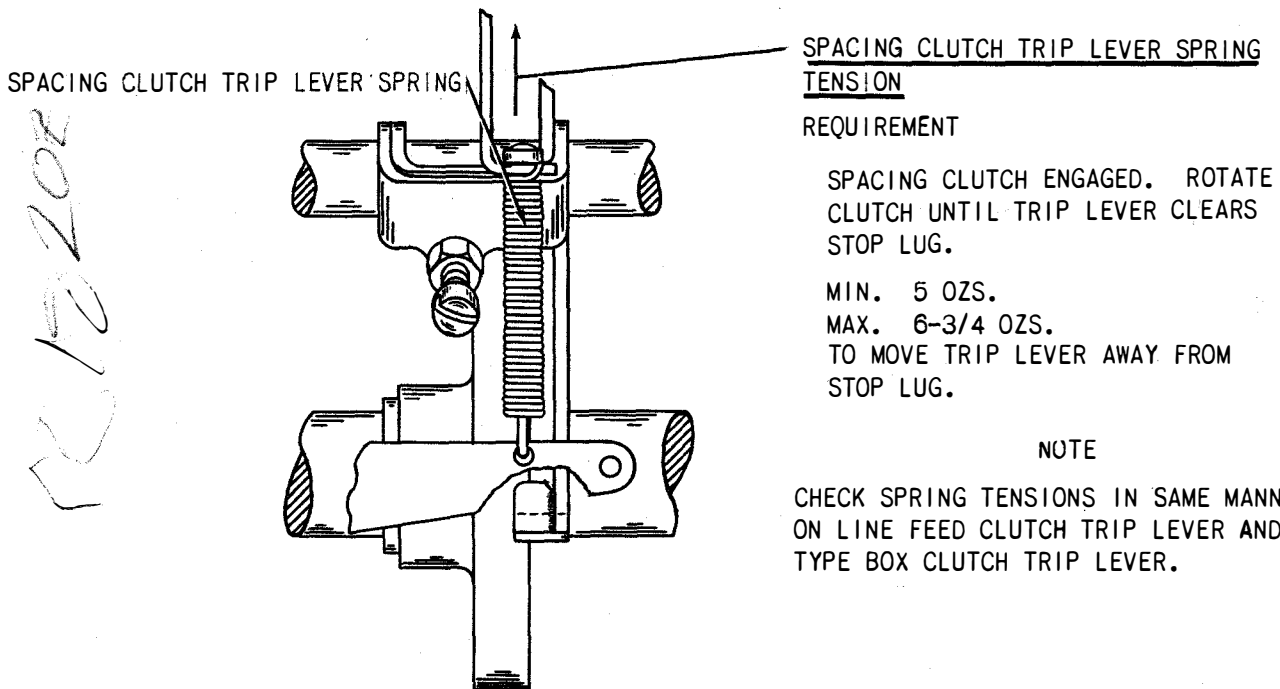
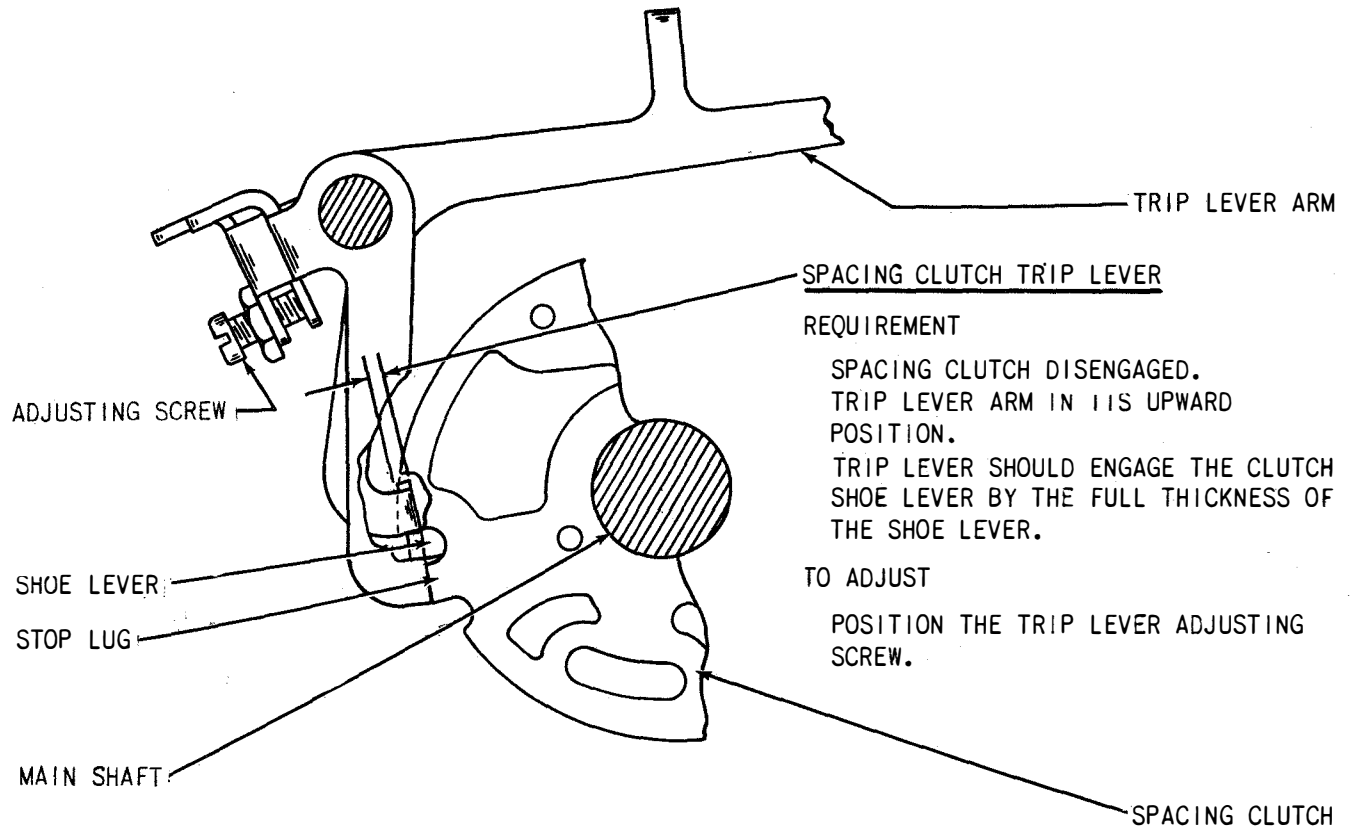


Figure 7-44. Automatic Typewriter, Spacing Clutch Mechanism

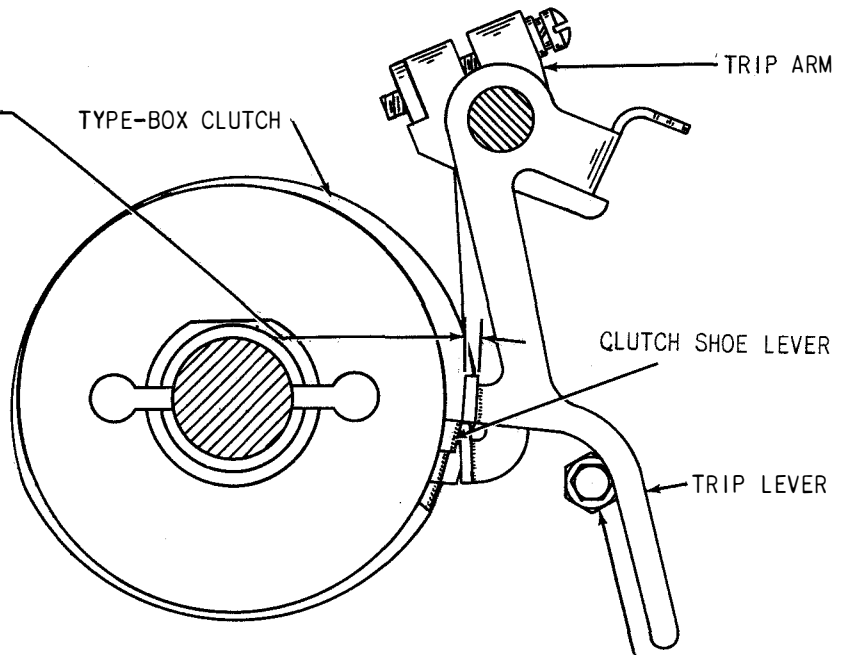
A. TYPE BOX CLUTCH TRIP LEVER  
ECCENTRIC POST

REQUIREMENT

TYPE BOX CLUTCH DISENGAGED.  
TRIP LEVER SHOULD ENGAGE THE CLUTCH  
SHOE LEVER BY THE FULL THICKNESS OF  
THE SHOE LEVER

TO ADJUST

POSITION THE TRIP LEVER ECCENTRIC  
POST.



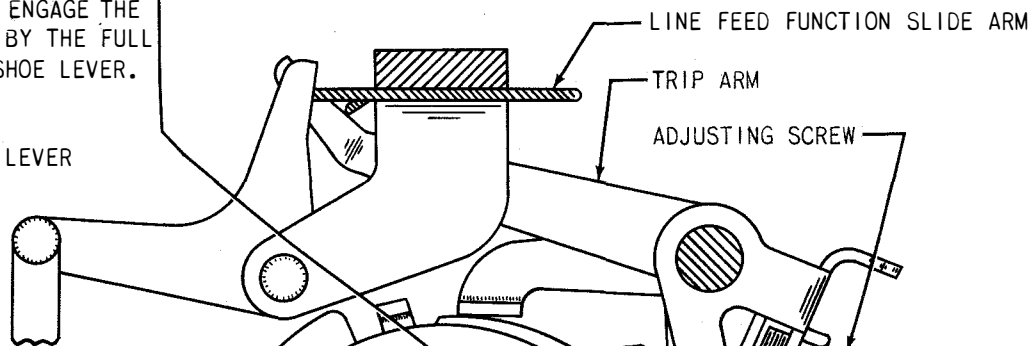
B. LINE FEED CLUTCH TRIP LEVER  
ECCENTRIC POST

REQUIREMENT

TRIP LEVER ADJUSTING SCREW  
TRIP OFF.  
LINE FEED CLUTCH IN ITS STOP  
POSITION.  
TRIP LEVER SHOULD ENGAGE THE  
CLUTCH SHOE LEVER BY THE FULL  
THICKNESS OF THE SHOE LEVER.

TO ADJUST

POSITION THE TRIP LEVER  
ECCENTRIC POST.



C. LINE FEED CLUTCH TRIP LEVER  
ADJUSTING SCREW

REQUIREMENT

LINE FEED FUNCTION SLIDE ARM  
IN REAR POSITION.  
CLUTCH TRIP LEVER AGAINST ITS  
ECCENTRIC POST.  
TRIP ARM HELD AGAINST ITS  
FUNCTION SLIDE ARM.  
SOME CLEARANCE BETWEEN THE  
END OF THE TRIP LEVER ADJUST-  
ING SCREW AND THE TRIP ARM.

MAX. 0.006 INCH

TO ADJUST

POSITION THE ADJUSTING SCREW.

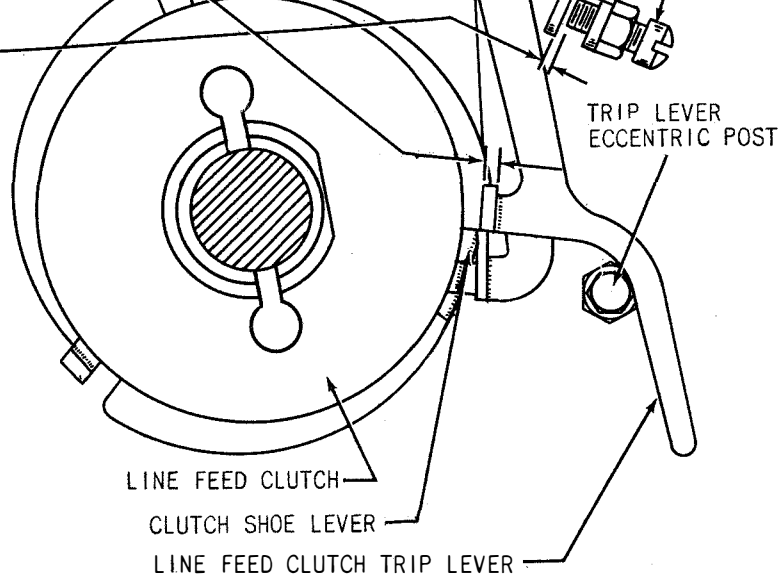
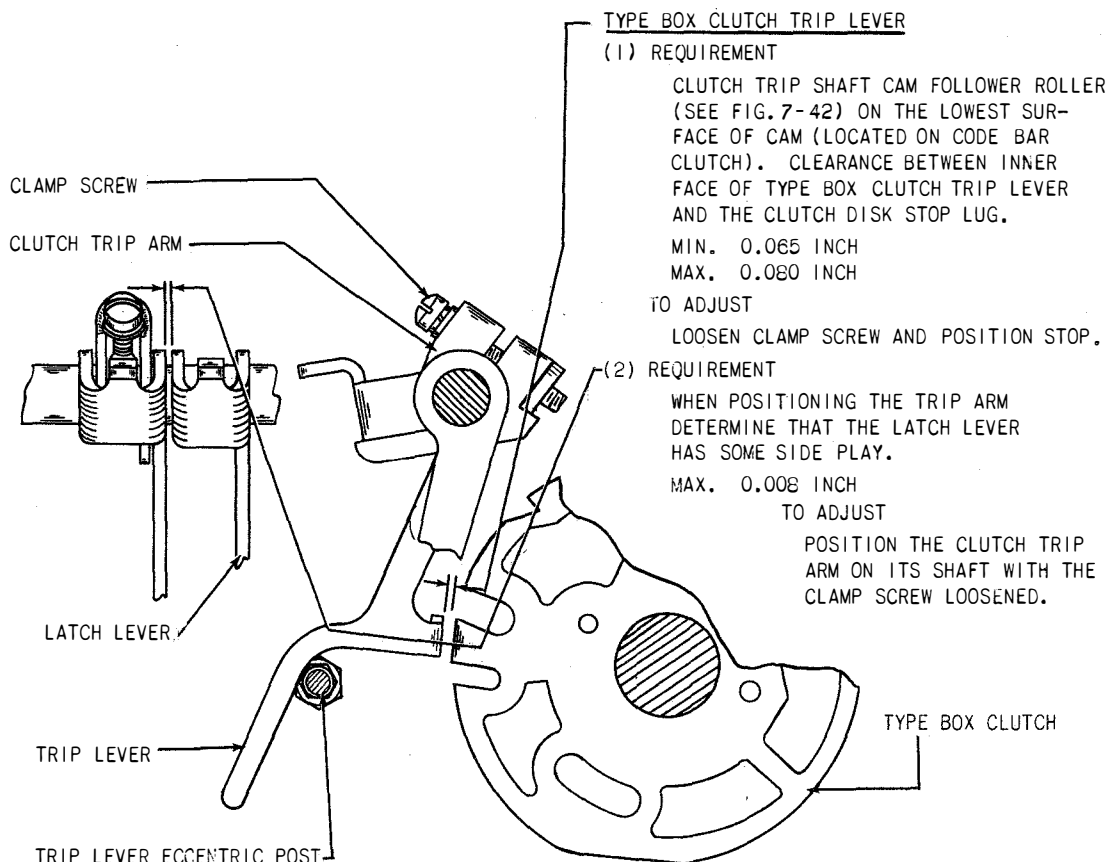
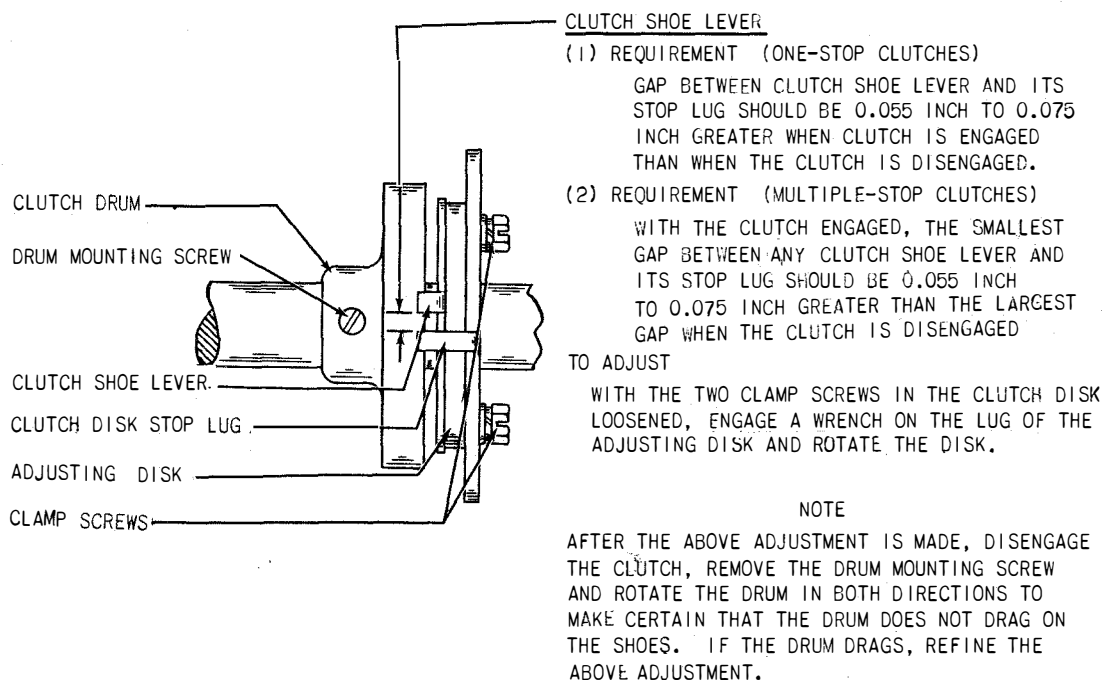


Figure 7-45. Automatic Typewriter, Type Box Clutch and Line Feed Clutch Mechanism



**Figure 7-46. Automatic Typewriter, Type Box Clutch Mechanism**



**Figure 7-47. Automatic Typewriter, Clutch Shoe Mechanism, All Clutches**

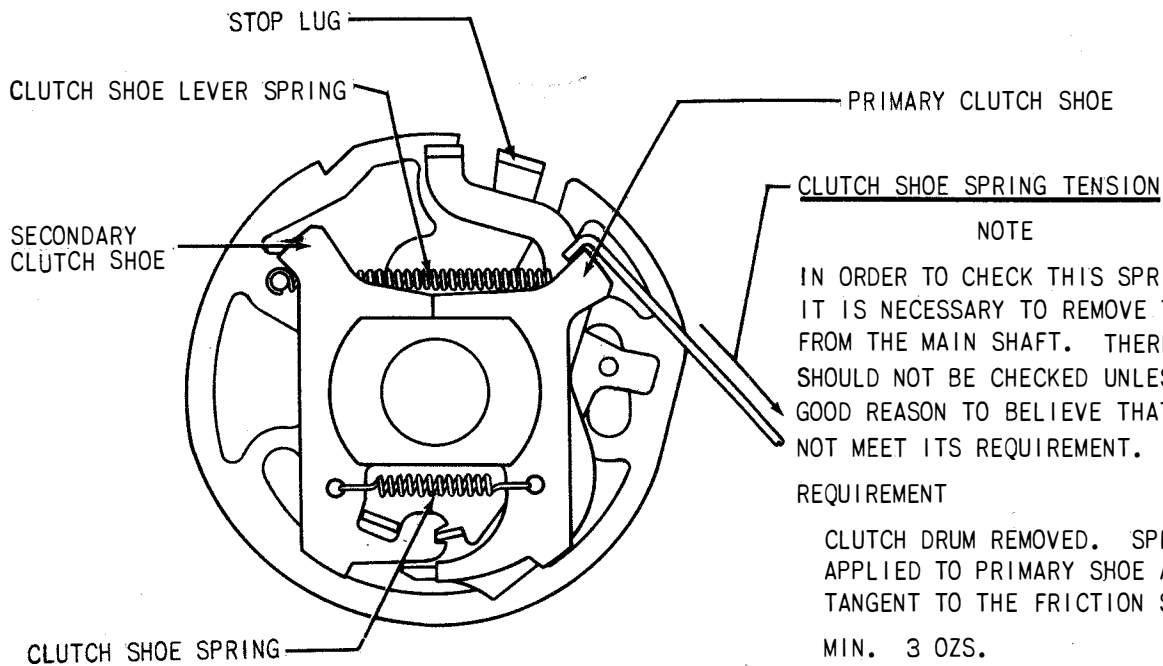
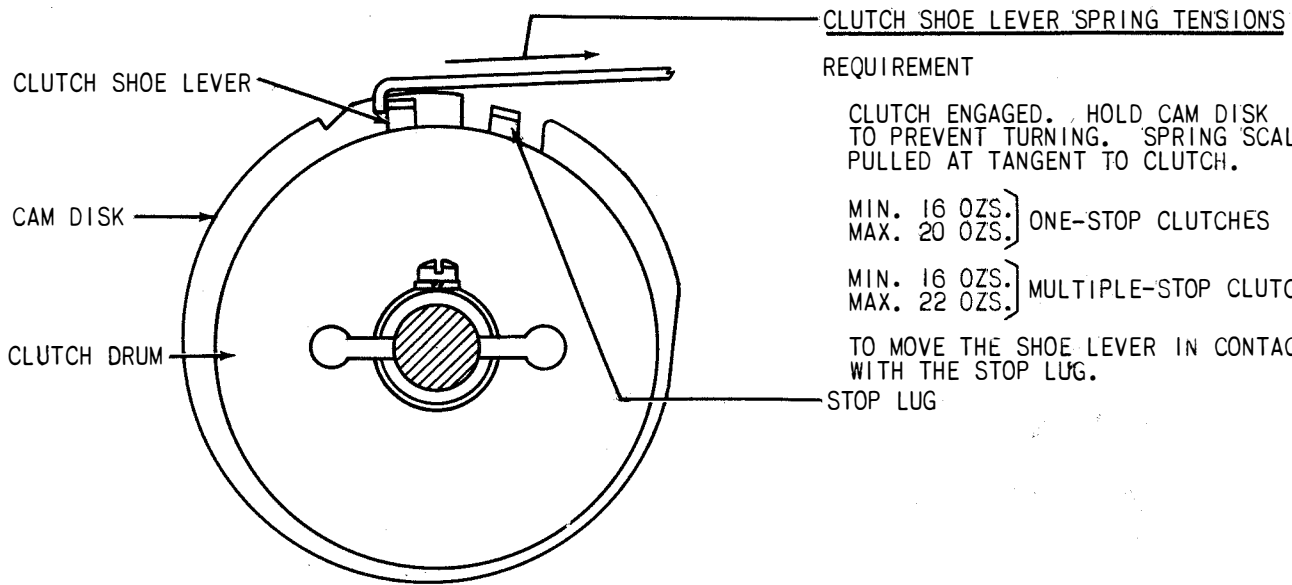


Figure 7-48. Automatic Typewriter, Clutch Mechanism

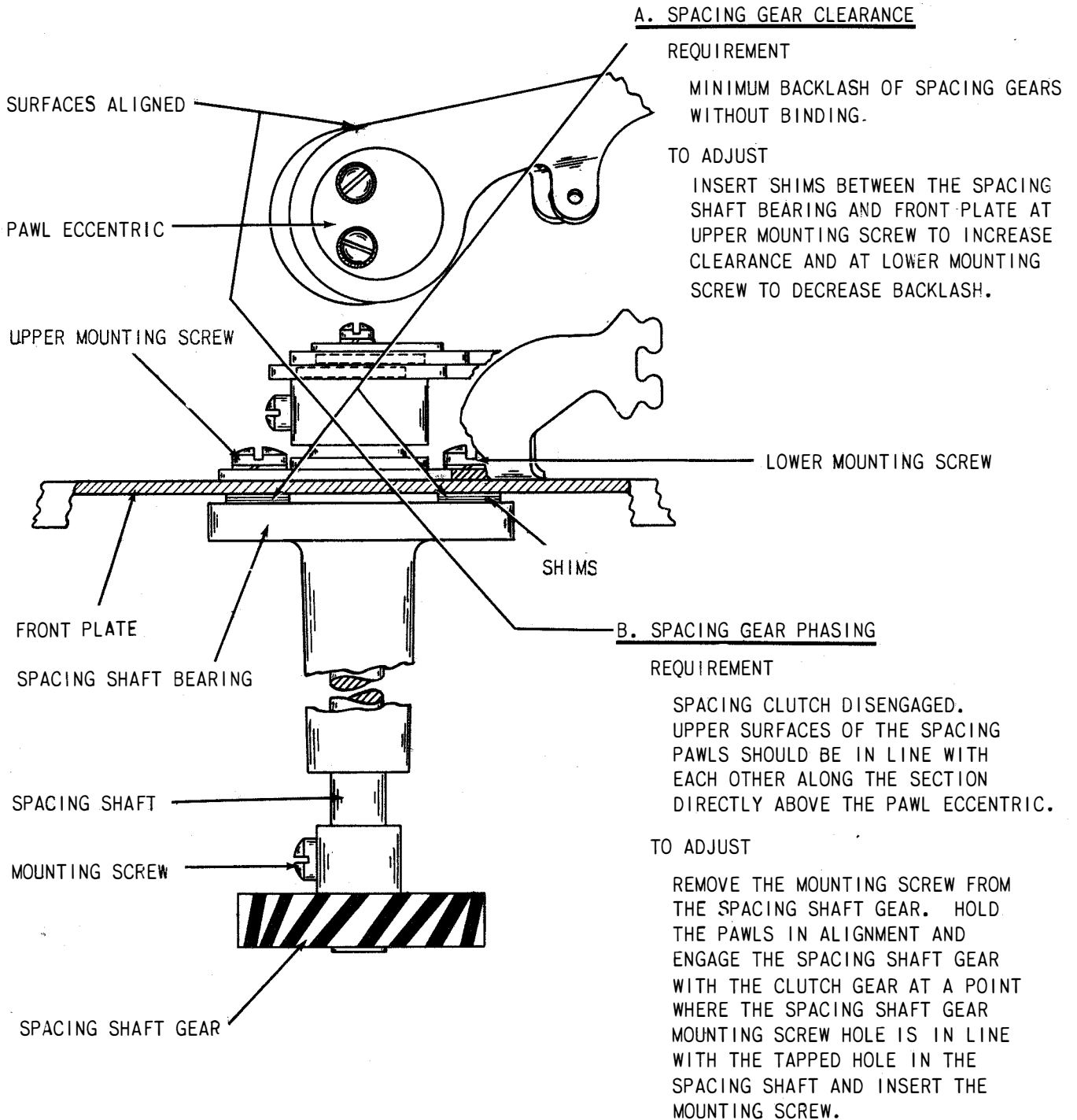


Figure 7-49. Automatic Typewriter, Spacing Mechanism

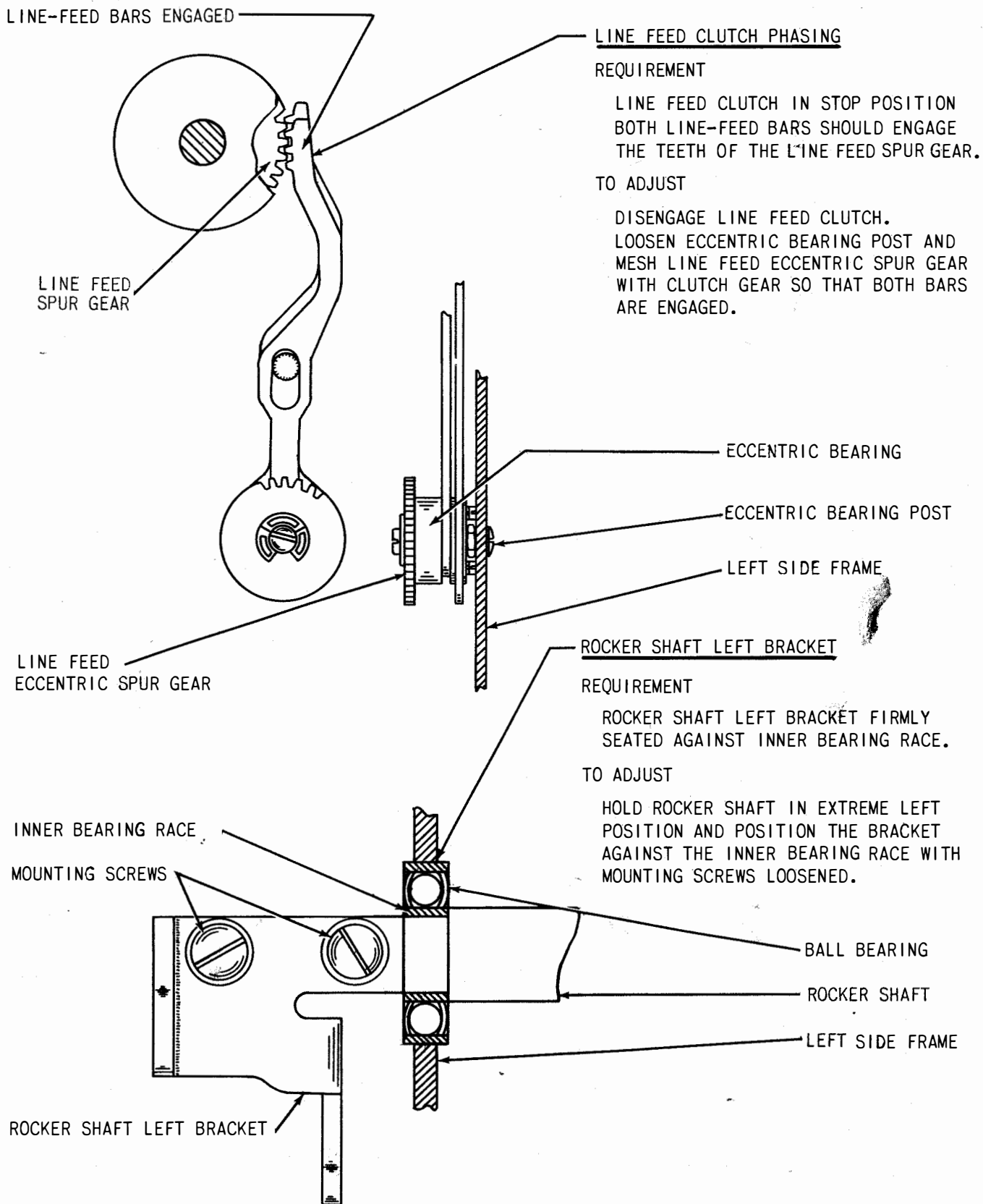
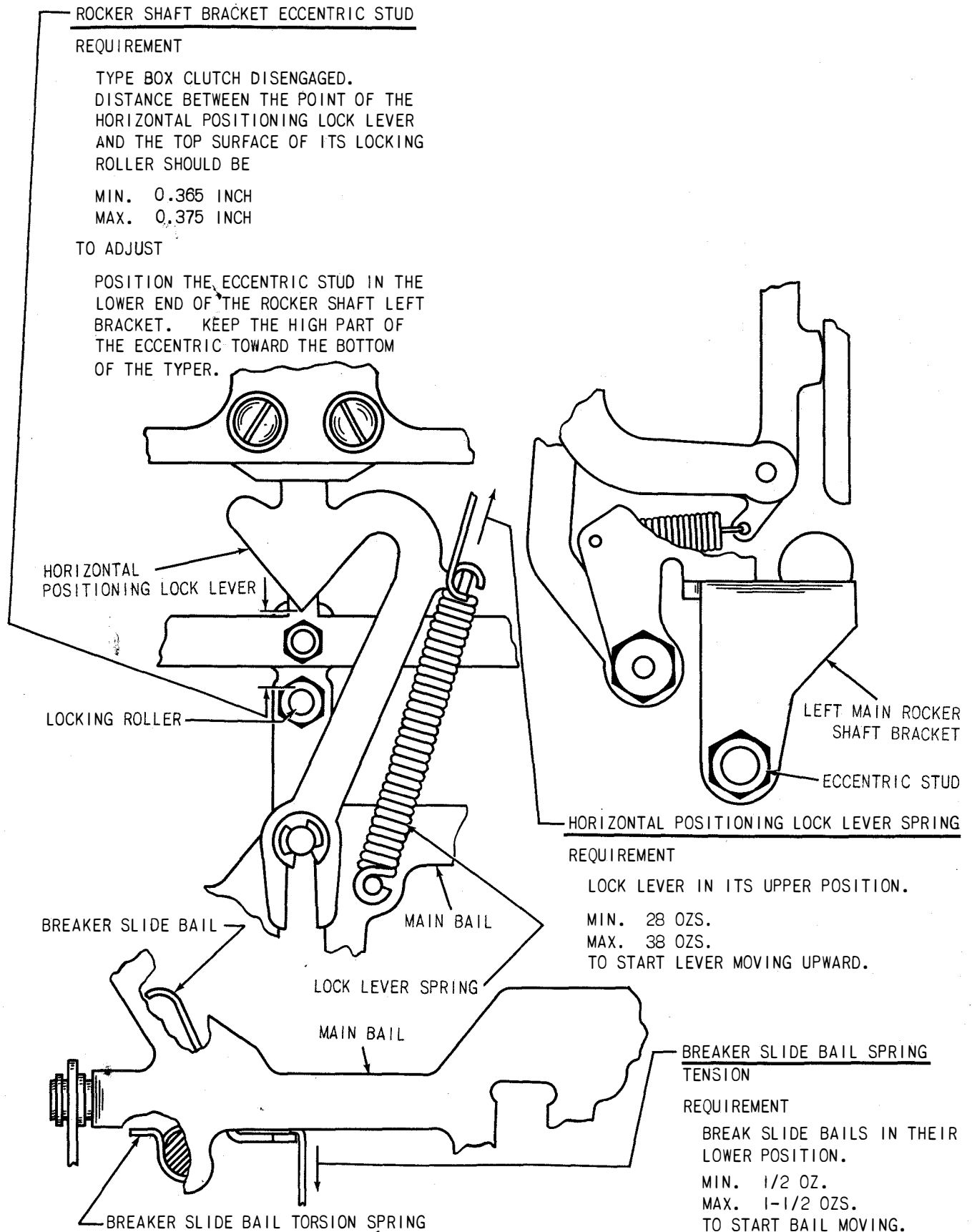
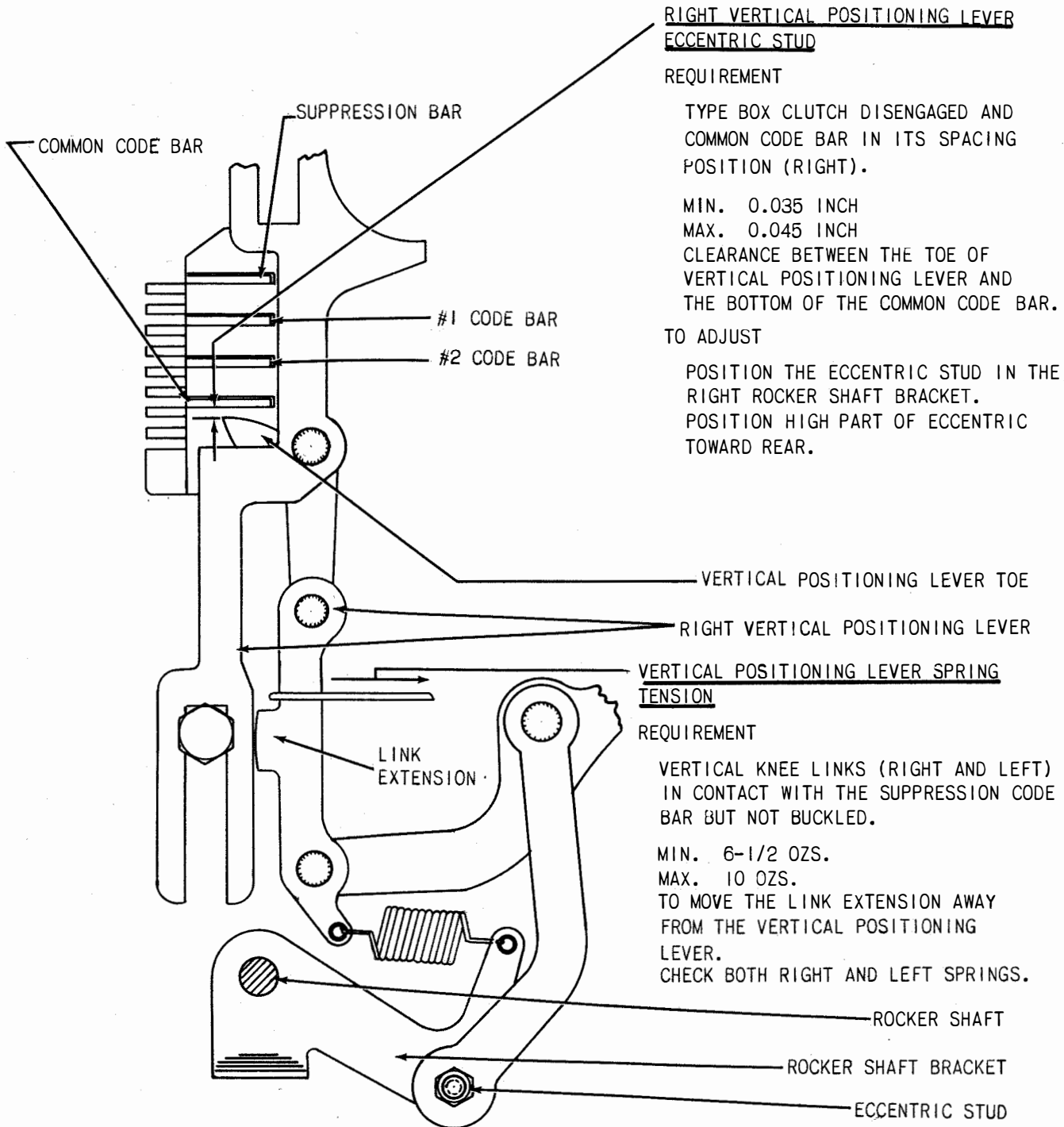


Figure 7-50. Automatic Typewriter, Line Feed and Rocker Shaft Mechanisms





**Figure 7-51. Automatic Typewriter, Shift and Positioning Mechanisms**



RIGHT VERTICAL POSITIONING LEVER  
ECCENTRIC STUD

REQUIREMENT

TYPE BOX CLUTCH DISENGAGED AND  
COMMON CODE BAR IN ITS SPACING  
POSITION (RIGHT).

MIN. 0.035 INCH  
MAX. 0.045 INCH

CLEARANCE BETWEEN THE TOE OF  
VERTICAL POSITIONING LEVER AND  
THE BOTTOM OF THE COMMON CODE BAR.

TO ADJUST

POSITION THE ECCENTRIC STUD IN THE  
RIGHT ROCKER SHAFT BRACKET.  
POSITION HIGH PART OF ECCENTRIC  
TOWARD REAR.

VERTICAL POSITIONING LEVER SPRING  
TENSION

REQUIREMENT

VERTICAL KNEE LINKS (RIGHT AND LEFT)  
IN CONTACT WITH THE SUPPRESSION CODE  
BAR BUT NOT BUCKLED.

MIN. 6-1/2 OZS.  
MAX. 10 OZS.

TO MOVE THE LINK EXTENSION AWAY  
FROM THE VERTICAL POSITIONING  
LEVER.  
CHECK BOTH RIGHT AND LEFT SPRINGS.

Figure 7-52. Automatic Typewriter, Vertical Positioning Mechanism, Right

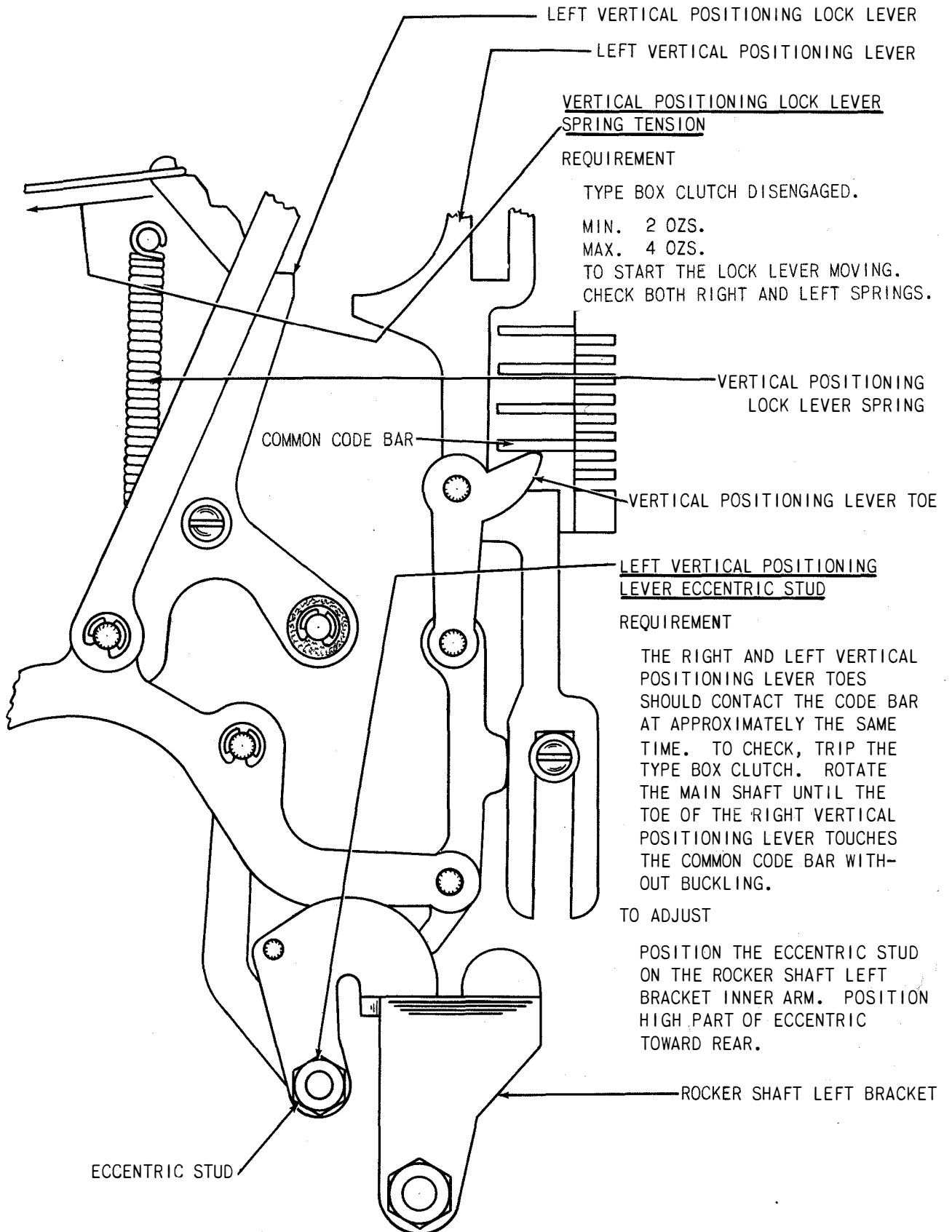


Figure 7-53. Automatic Typewriter, Vertical Positioning Mechanism, Left

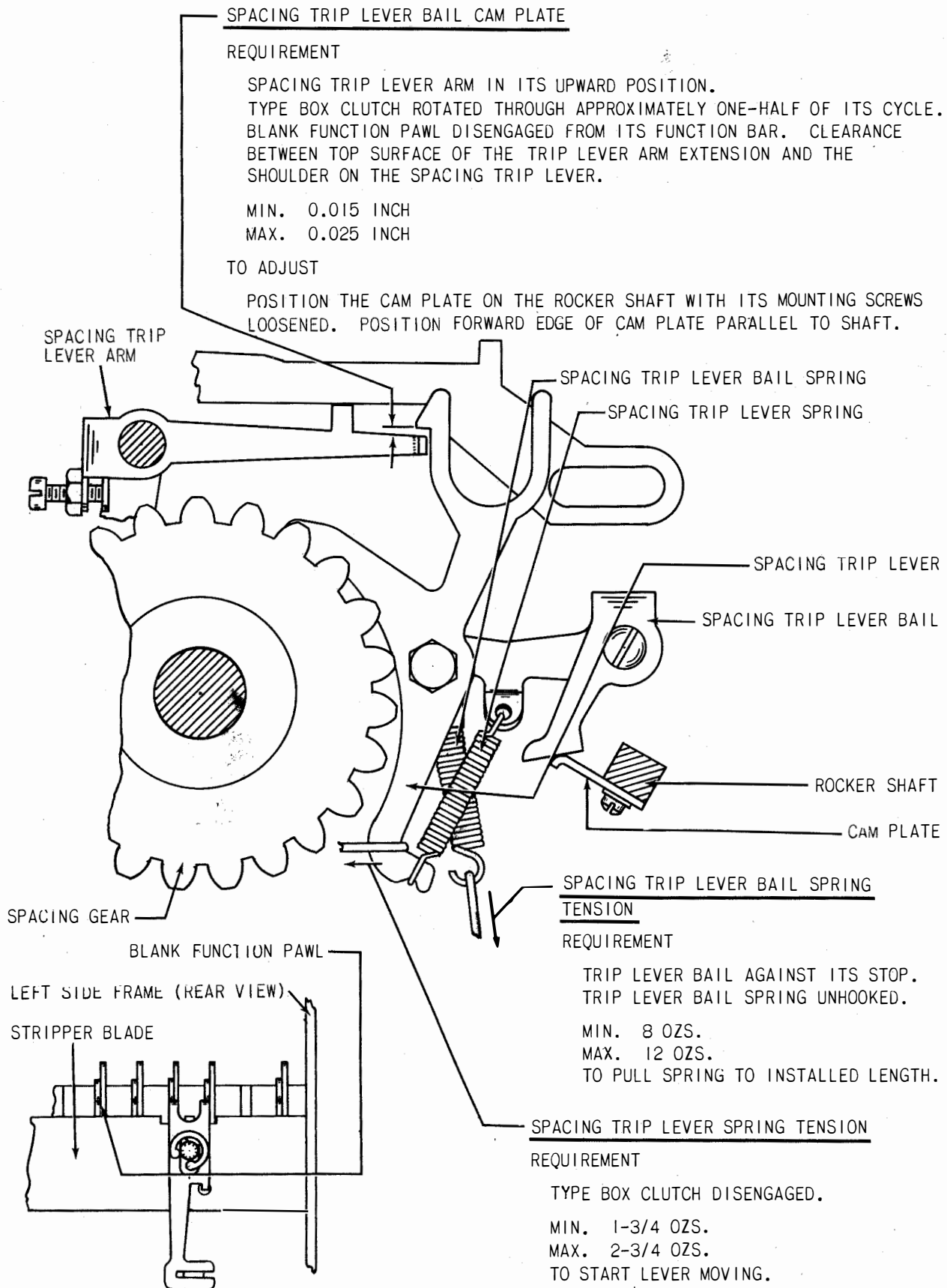


Figure 7-54. Automatic Typewriter, Spacing Mechanism

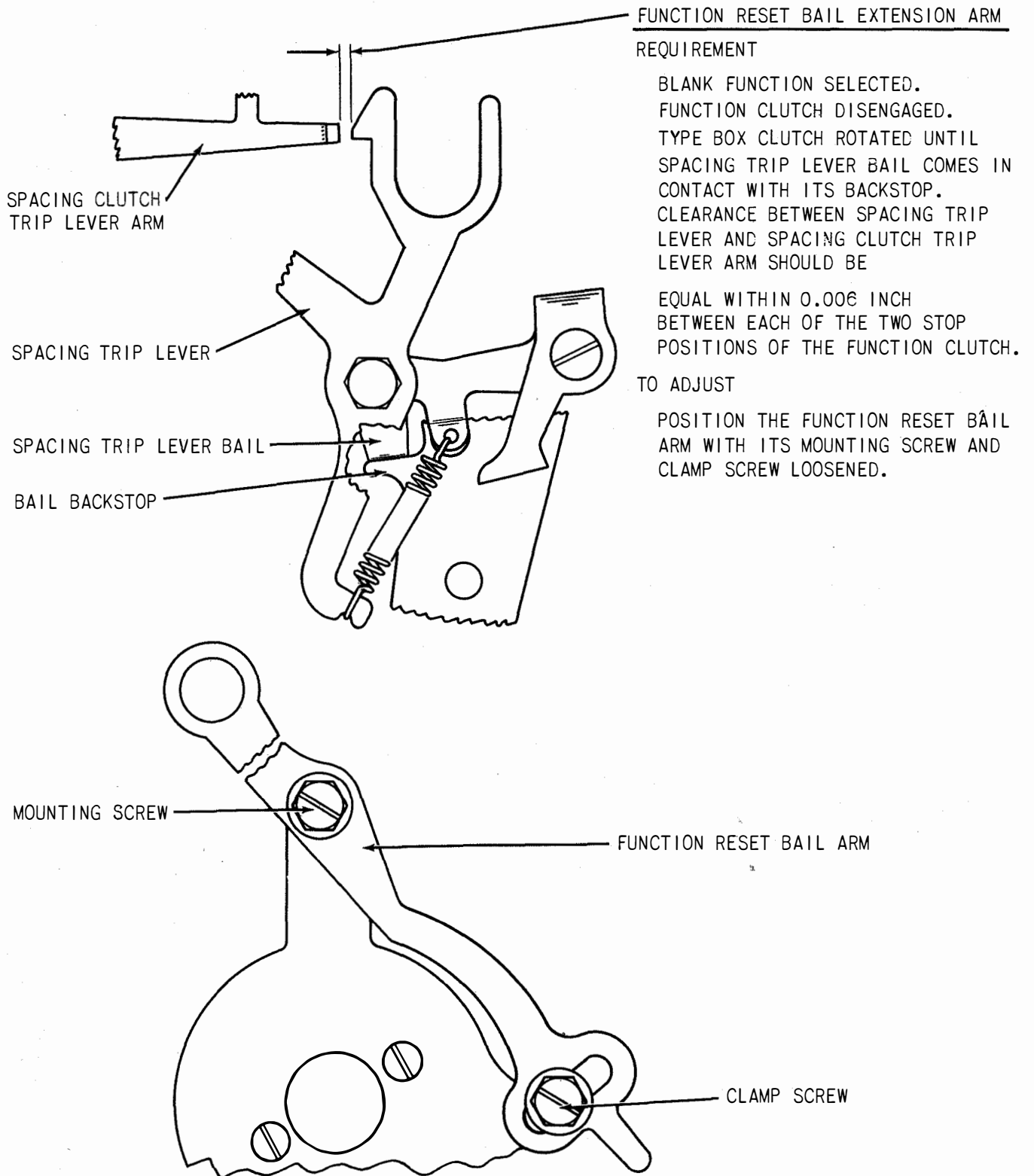
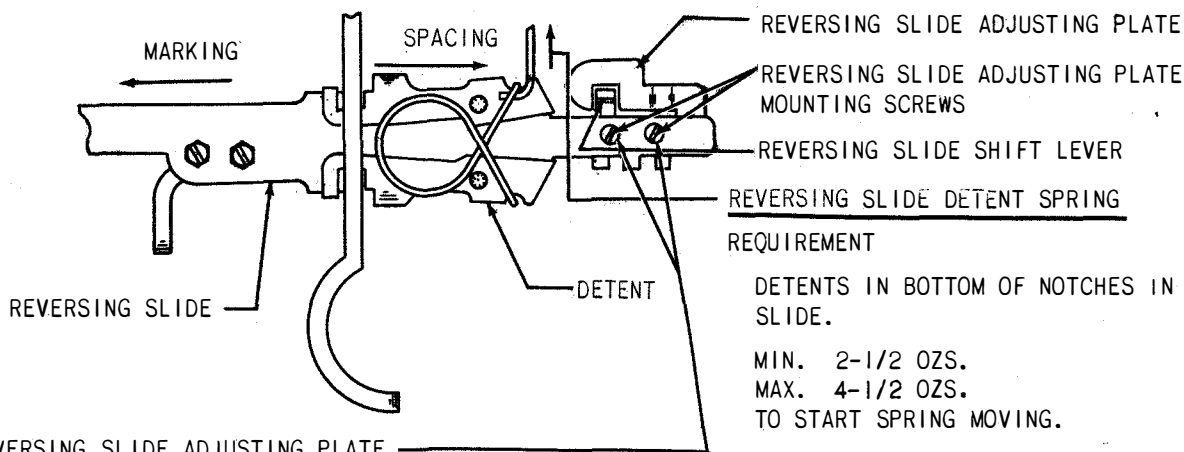


Figure 7-55. Automatic Typewriter, Function Reset Bail Extension Arm



REVERSING SLIDE ADJUSTING PLATE  
REQUIREMENT

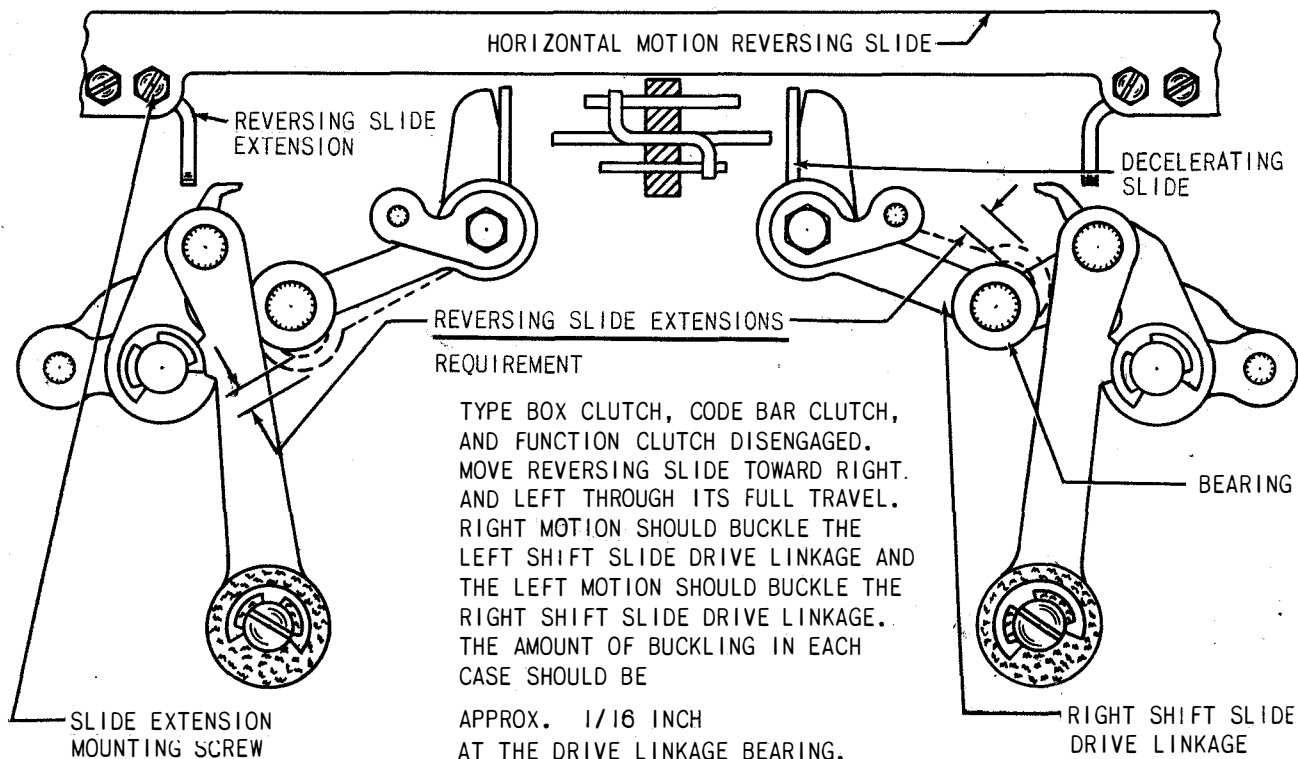
TYPE BOX CLUTCH DISENGAGED.

WITH NO. 3 CODE BAR IN SPACING POSITION (RIGHT), THE REVERSING SLIDE DETENTS SHOULD BE FULLY SEATED IN ITS LEFT-HAND NOTCHES OF THE SLIDE.

WITH NO. 3 CODE BAR IN MARKING POSITION (LEFT), THE REVERSING SLIDE DETENTS SHOULD BE FULLY SEATED IN RIGHT-HAND NOTCHES OF THE SLIDE.

TO ADJUST

POSITION THE REVERSING SLIDE ADJUSTING PLATE WITH ITS MOUNTING SCREWS LOOSENED.



TO ADJUST

POSITION THE REVERSING SLIDE EXTENSIONS WITH THEIR MOUNTING SCREWS LOOSENED.

Figure 7-56. Automatic Typewriter, Horizontal Motion Reversing Mechanism

SHIFT SLIDE DRIVE LINKAGE

REQUIREMENT

TYPE BOX CLUTCH DISENGAGED.

CODE BARS 4 AND 5 TO SPACING (RIGHT).

CLEARANCE BETWEEN EACH SIDE OF CENTER HORIZONTAL STOP SLIDE AND DECELERATING SLIDES SHOULD BE EQUAL (WITHIN 0.005 INCH).

MIN. 0.020 INCH

MAX. 0.040 INCH

TO ADJUST

LOOSEN TWO MOUNTING SCREWS OF BOTH BEARING STUDS (INNER TWO FRICTION TIGHT). POSITION ONE OR BOTH BEARING STUDS ON THE CONNECTING STRIP TO PROVIDE 0.025 INCH TO 0.035 INCH BETWEEN THE CENTER HORIZONTAL SLIDE AND THE DECELERATING SLIDE ON THE SIDE WHERE THE LINKAGE IS NOT BUCKLED. TIGHTEN THE TWO INNER MOUNTING SCREWS. CHANGE POSITION OF REVERSING SLIDE AND CHECK OPPOSITE CLEARANCE. EQUALIZE BY SHIFTING BOTH STUDS AND CONNECTING STRIP AS A UNIT. TIGHTEN THE TWO OUTER MOUNTING SCREWS.

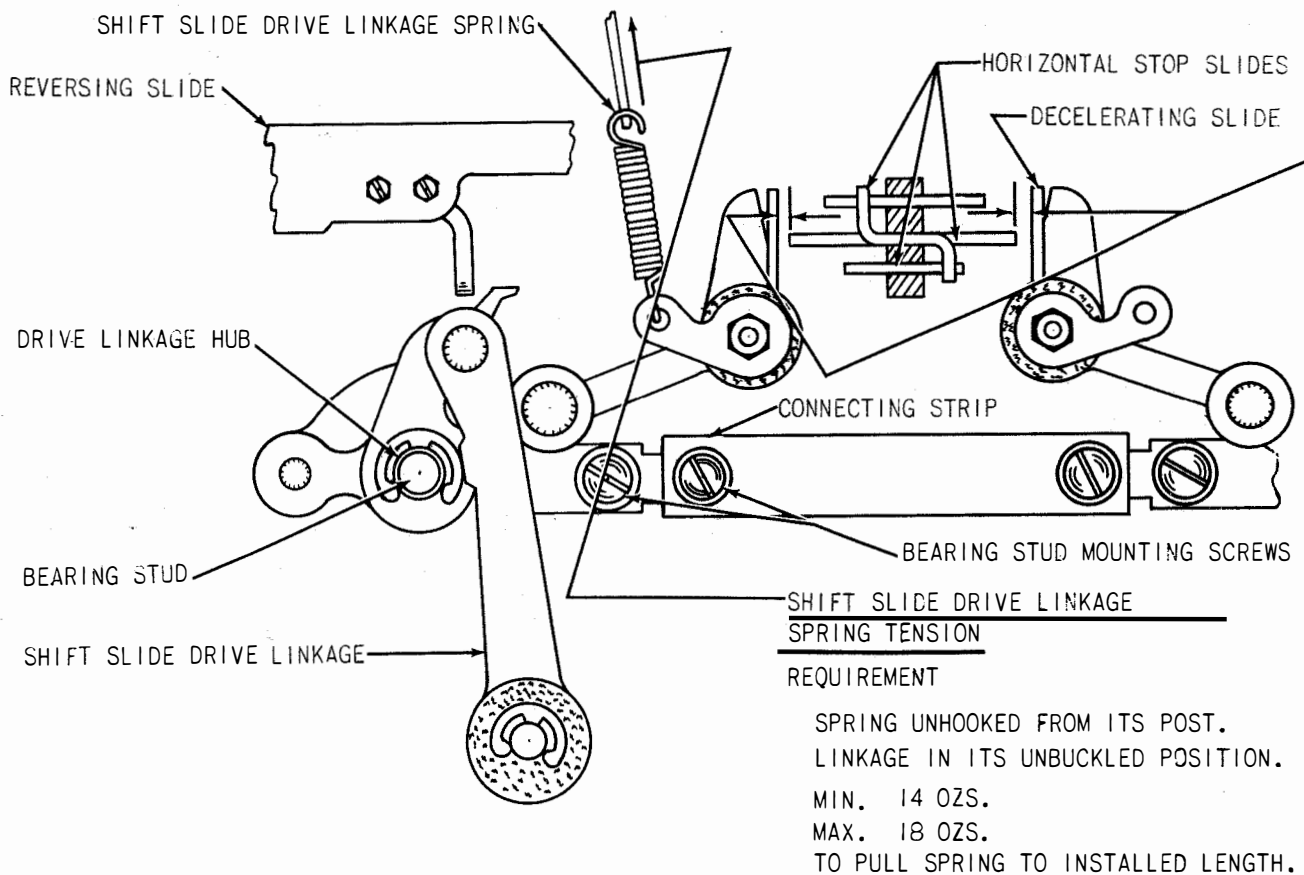


Figure 7-57. Automatic Typewriter, Shift Slide Drive Mechanism

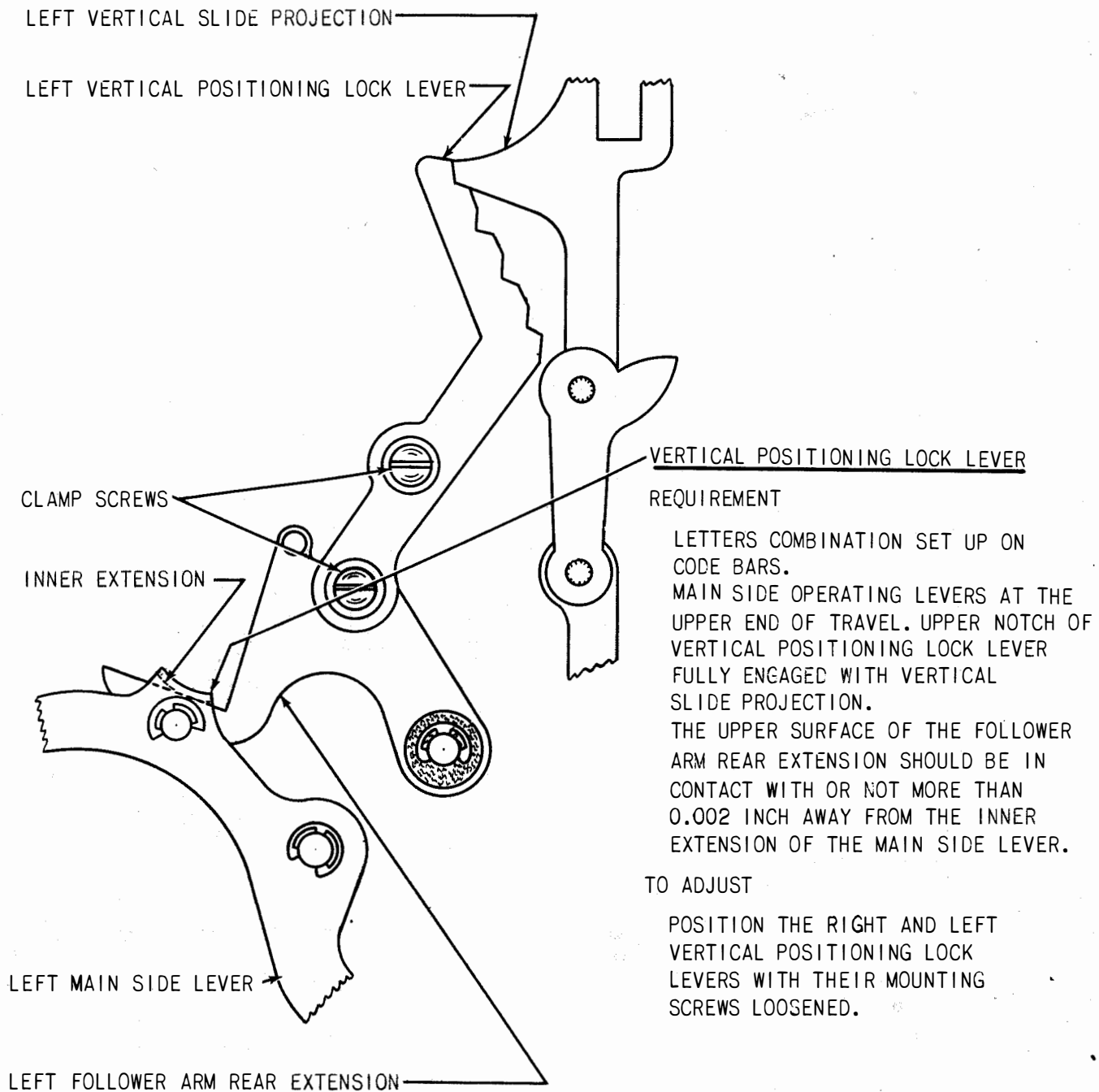


Figure 7-58. Automatic Typewriter, Vertical Positioning Mechanism



SPACING DRUM STOP ARM

REQUIREMENT

SPACING CLUTCH DISENGAGED.  
SPACING DRUM FULLY RETURNED.  
CLEARANCE AT CLOSEST POINT BETWEEN  
OPERATING FACE OF SPACING FEED PAWL  
THAT IS FARTHEST ADVANCED AND  
THE FACE OF A TOOTH ON RATCHET  
WHEEL

MIN. 0.006 INCH  
MAX. 0.012 INCH

TO ADJUST

POSITION THE STOP ARM ON THE  
RATCHET WHEEL, APPROXIMATELY  
IN THE MIDDLE OF ITS ADJUST-  
ING RANGE, WITH ITS MOUNTING  
SCREWS LOOSENED.

STOP ARM MOUNTING SCREW

SPACING FEED PAWL SPRING TENSION

REQUIREMENT

SPACING CLUTCH DISENGAGED.  
SPACING FEED PAWL AGAINST  
RATCHET WHEEL.  
BOTH SPRINGS UNHOOKED FROM SPRING  
BRACKET.

MIN. 2-1/2 OZS.  
MAX. 4 OZS.  
TO PULL SPRINGS TO INSTALLED LENGTH.

SPACING FEED  
PAWL SPRING BRACKET

AUTOMATIC CR-LF BELL CRANK SPRING  
TENSION

REQUIREMENT

FUNCTION CLUTCH DISENGAGED.

MIN. 8 OZS.  
MAX. 11 OZS.  
TO MOVE THE BELL CRANK.

SPACING FEED PAWL

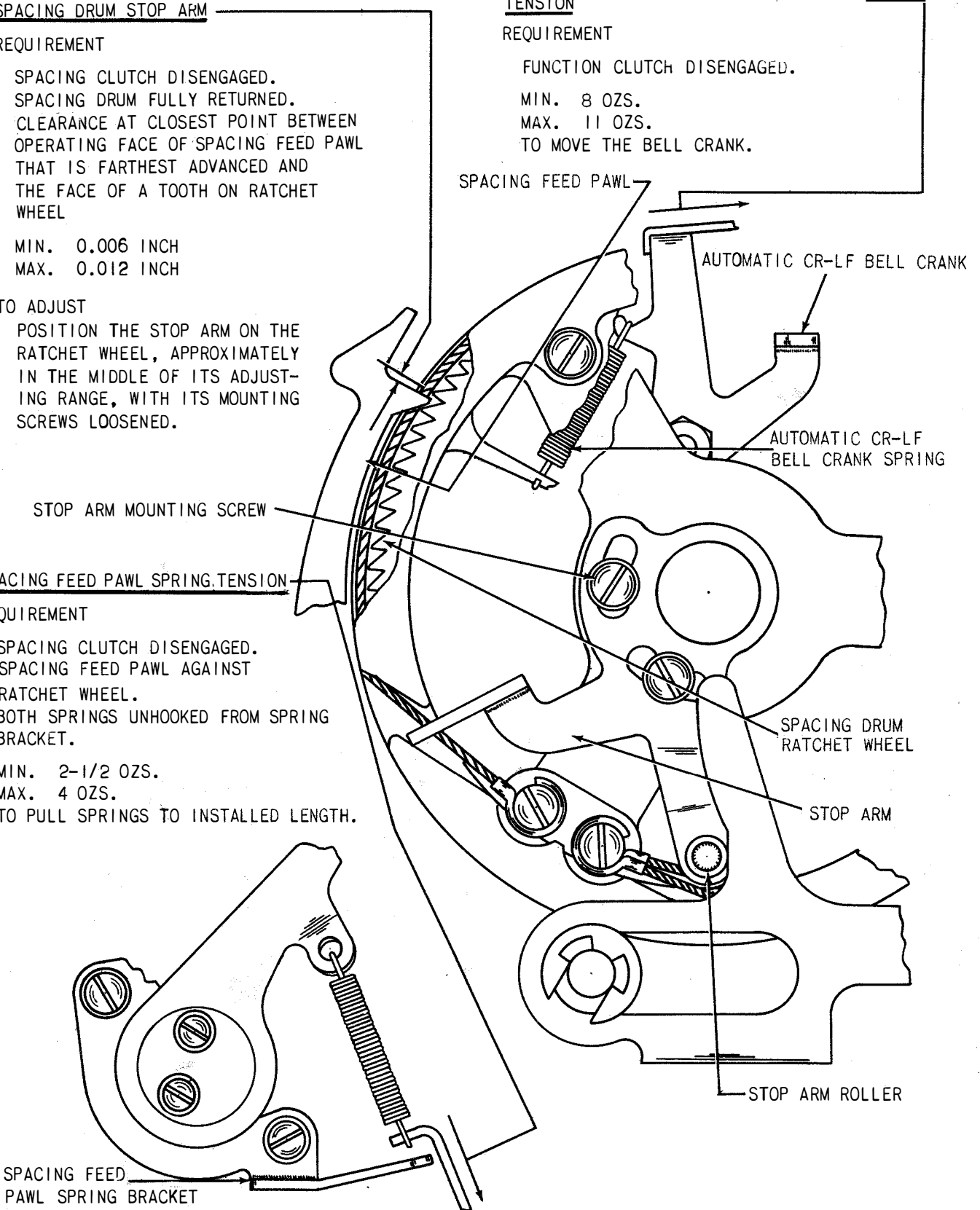
AUTOMATIC CR-LF BELL CRANK

AUTOMATIC CR-LF  
BELL CRANK SPRING

SPACING DRUM  
RATCHET WHEEL

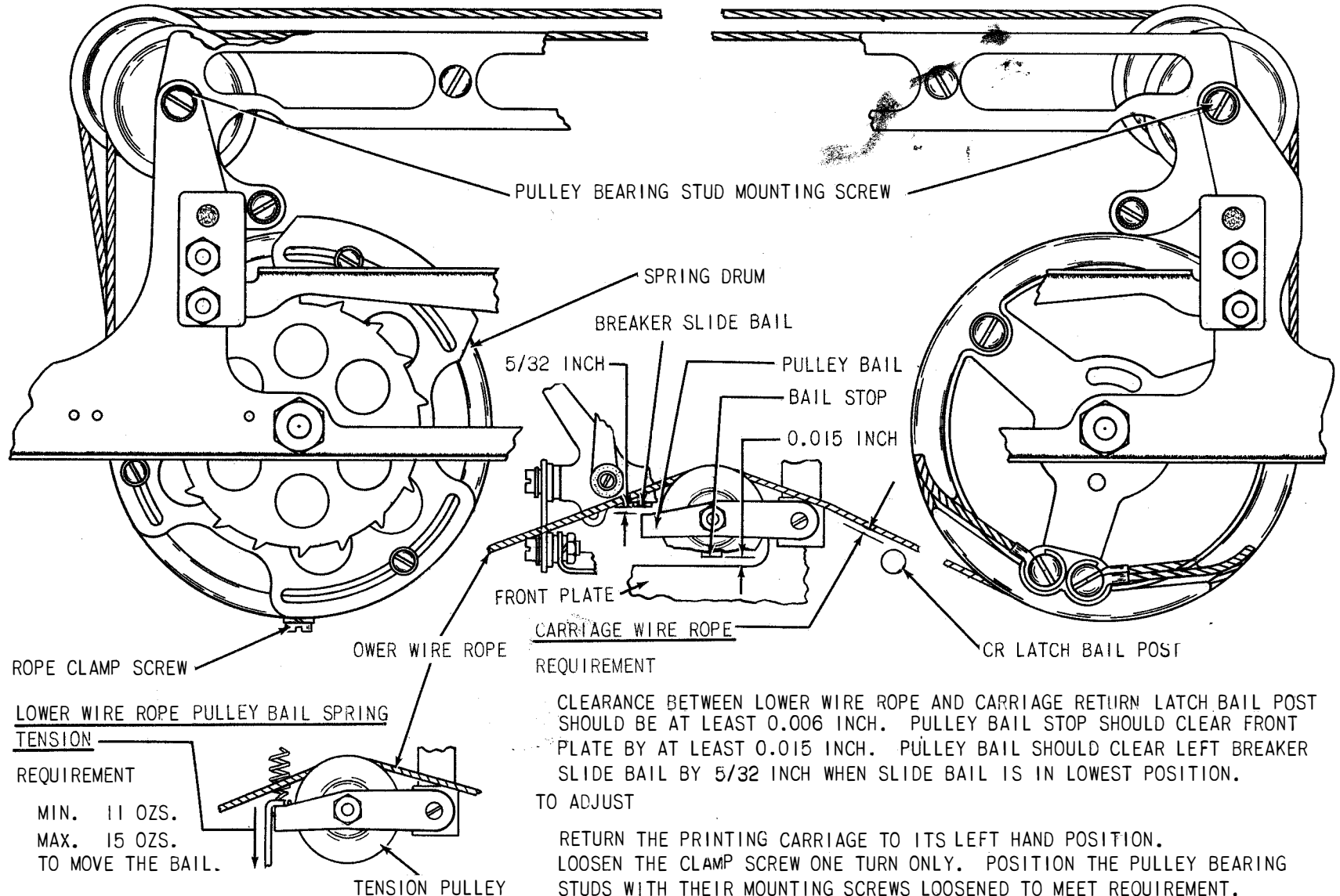
STOP ARM

STOP ARM ROLLER



**Figure 7-59. Automatic Typewriter, Spacing Mechanism**

Figure 7-60. Automatic Typewriter, Spacing Mechanism



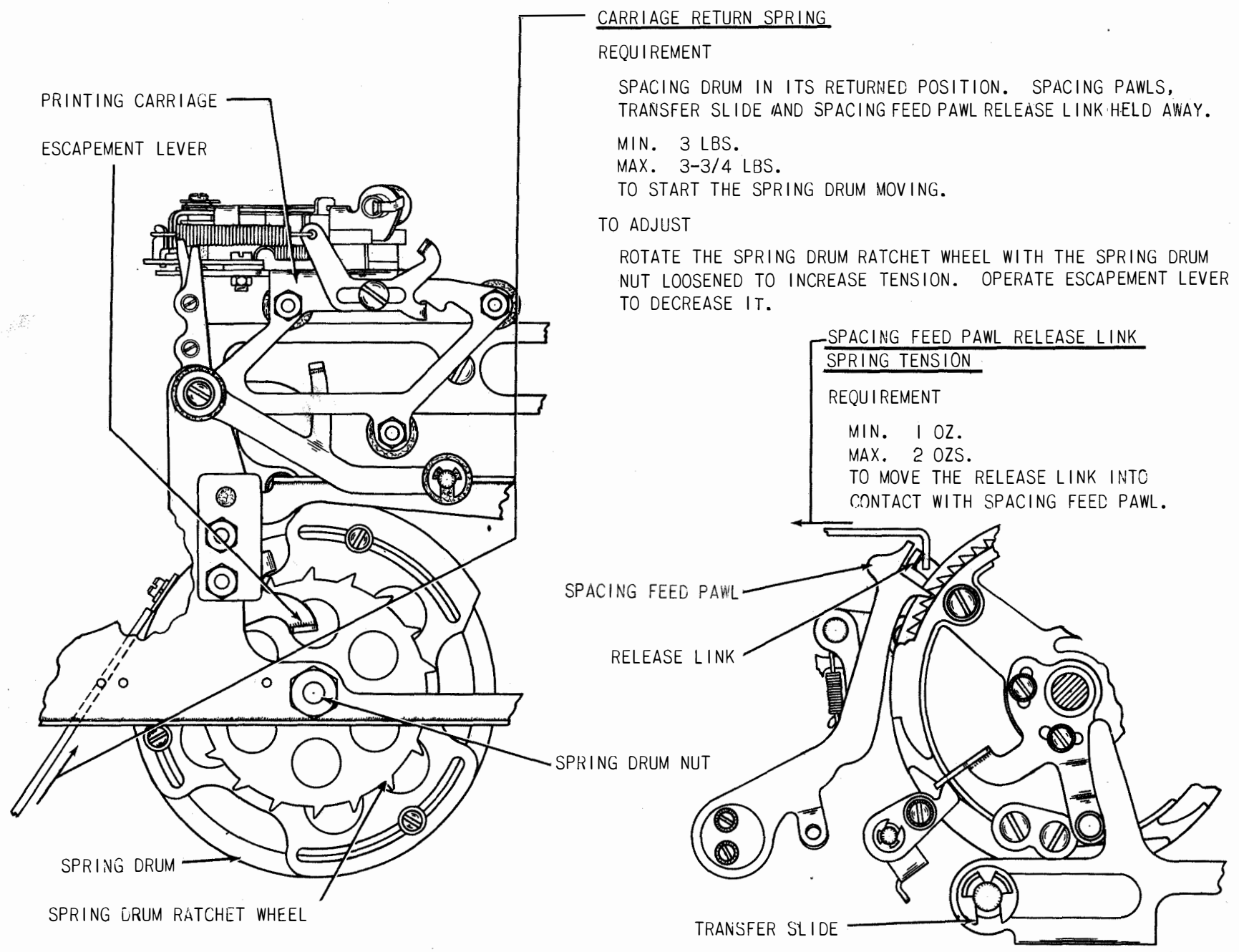
LOWER WIRE ROPE PULLEY BAIL SPRING TENSION  
 REQUIREMENT  
 MIN. 11 OZS.  
 MAX. 15 OZS.  
 TO MOVE THE BAIL.

CARRIAGE WIRE ROPE REQUIREMENT  
 CLEARANCE BETWEEN LOWER WIRE ROPE AND CARRIAGE RETURN LATCH BAIL POST SHOULD BE AT LEAST 0.006 INCH. PULLEY BAIL STOP SHOULD CLEAR FRONT PLATE BY AT LEAST 0.015 INCH. PULLEY BAIL SHOULD CLEAR LEFT BREAKER SLIDE BAIL BY 5/32 INCH WHEN SLIDE BAIL IS IN LOWEST POSITION.  
 TO ADJUST

RETURN THE PRINTING CARRIAGE TO ITS LEFT HAND POSITION. LOOSEN THE CLAMP SCREW ONE TURN ONLY. POSITION THE PULLEY BEARING STUDS WITH THEIR MOUNTING SCREWS LOOSENED TO MEET REQUIREMENT. MAKE CERTAIN THAT THE ROPE MOVES AROUND ITS CLAMP SCREW TO AN EQUALIZED POSITION. TIGHTEN CLAMP SCREW AND MOUNTING SCREWS.

ORIGINAL

Figure 7-61. Automatic Typewriter, Carriage Return Mechanism



7-69

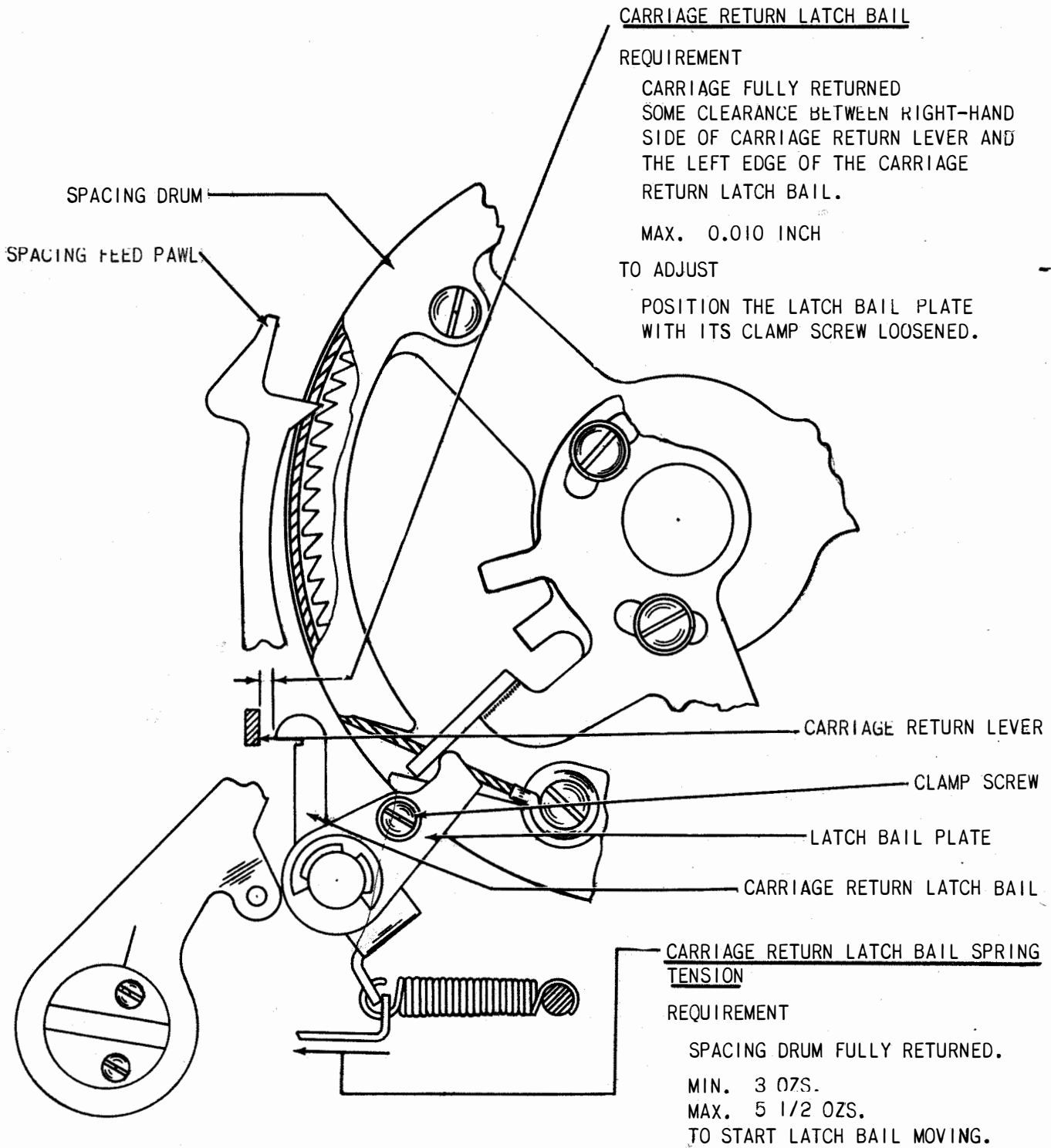
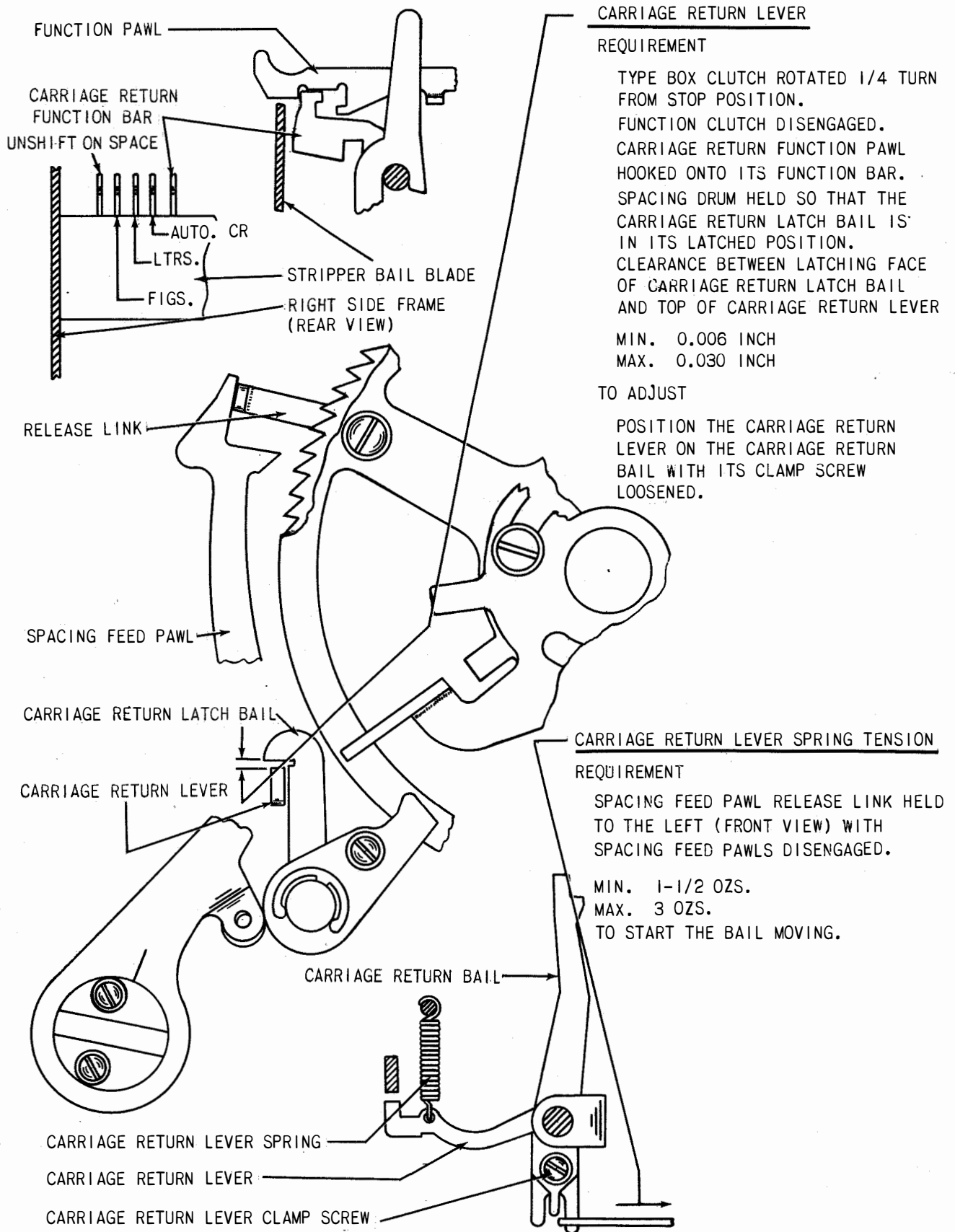


Figure 7-62. Automatic Typewriter, Carriage Return Mechanism



**Figure 7-63. Automatic Typewriter, Carriage Return Mechanism**

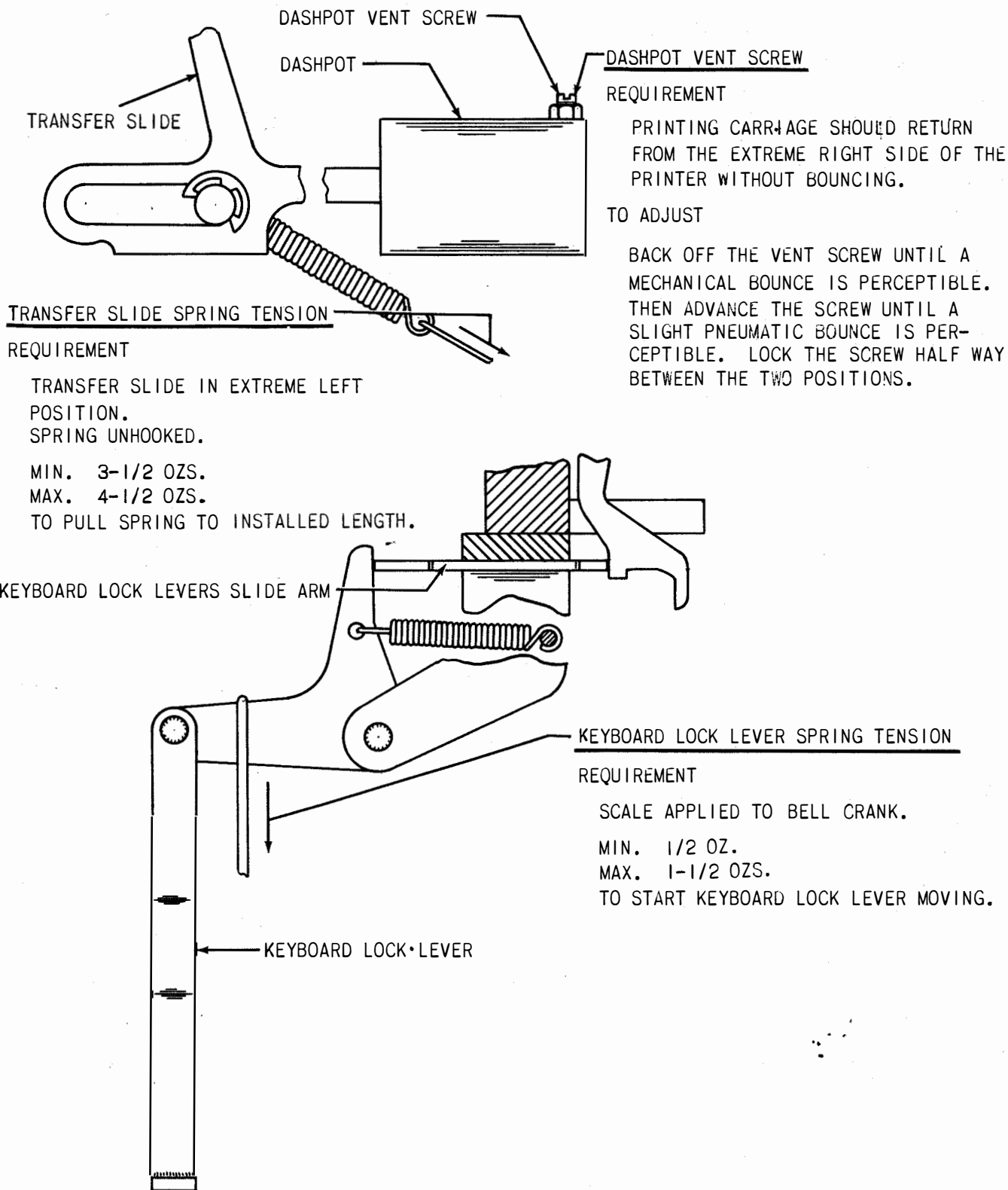
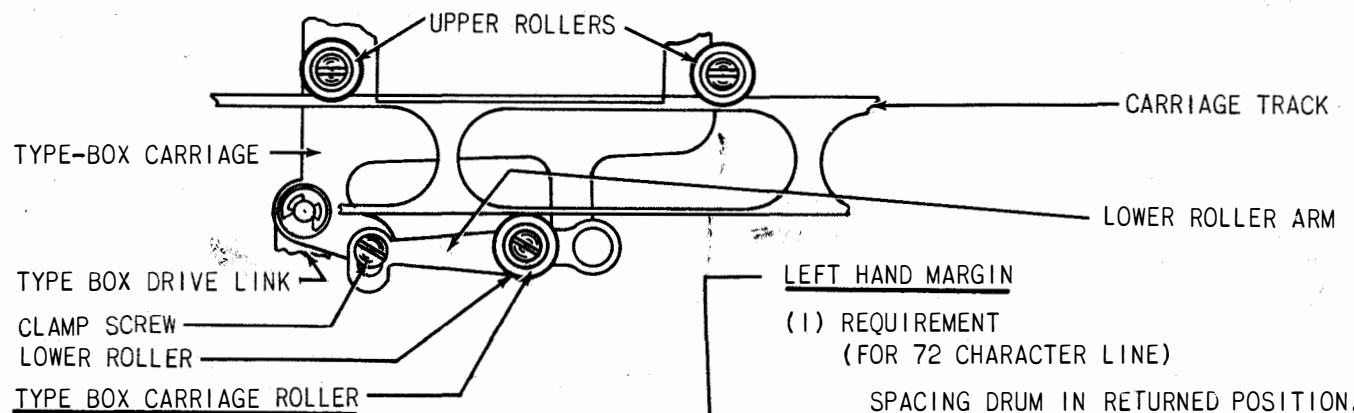


Figure 7-64. Automatic Typewriter, Dashpot and Keyboard Lock Mechanisms

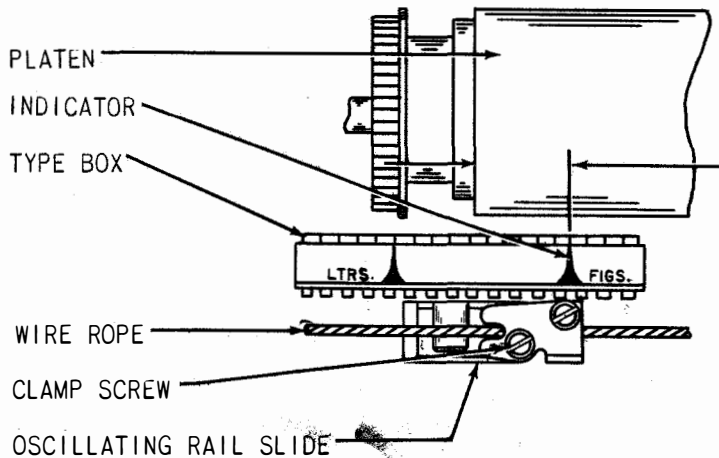


**REQUIREMENT**

MINIMUM AMOUNT OF VERTICAL PLAY WITHOUT BIND IN THE TYPE BOX CARRIAGE. TO CHECK, MOVE CARRIAGE TO RIGHT END OF TRACK AND PLACE IN UPPER POSITION. REMOVE DRIVE LINK AND CHECK THROUGHOUT THE ENTIRE TRAVEL OF CARRIAGE.

**TO ADJUST**

POSITION THE LOWER ROLLER ARM WITH ITS CLAMP SCREW LOOSENED.



**LEFT HAND MARGIN**

**(1) REQUIREMENT  
(FOR 72 CHARACTER LINE)**

SPACING DRUM IN RETURNED POSITION. TYPE BOX SHIFTED TO THE FIGURES POSITION. CENTER OF THE FIGURES PRINT INDICATOR ON THE TYPE BOX SHOULD BE

MIN. 5/8 INCH

MAX. 3/4 INCH

FROM THE LEFT EDGE OF THE PLATEN.

**TO ADJUST**

POSITION THE TYPE BOX OSCILLATING RAIL SLIDE ON ITS WIRE ROPE WITH ITS CLAMP SCREWS LOOSENED.

**(2) REQUIREMENT**

FOR LINES OTHER THAN 72 CHARACTERS IN LENGTH, THE MARGIN MAY BE VARIED AS REQUIRED.

**TO ADJUST**

REPOSITION THE STOP ARM ON THE SPACING DRUM WITH ITS MOUNTING SCREWS LOOSENED.

NOTE: RECHECK SPACING DRUM STOP ARM REQUIREMENT.

**Figure 7-65. Automatic Typewriter, Type Box Mechanism**

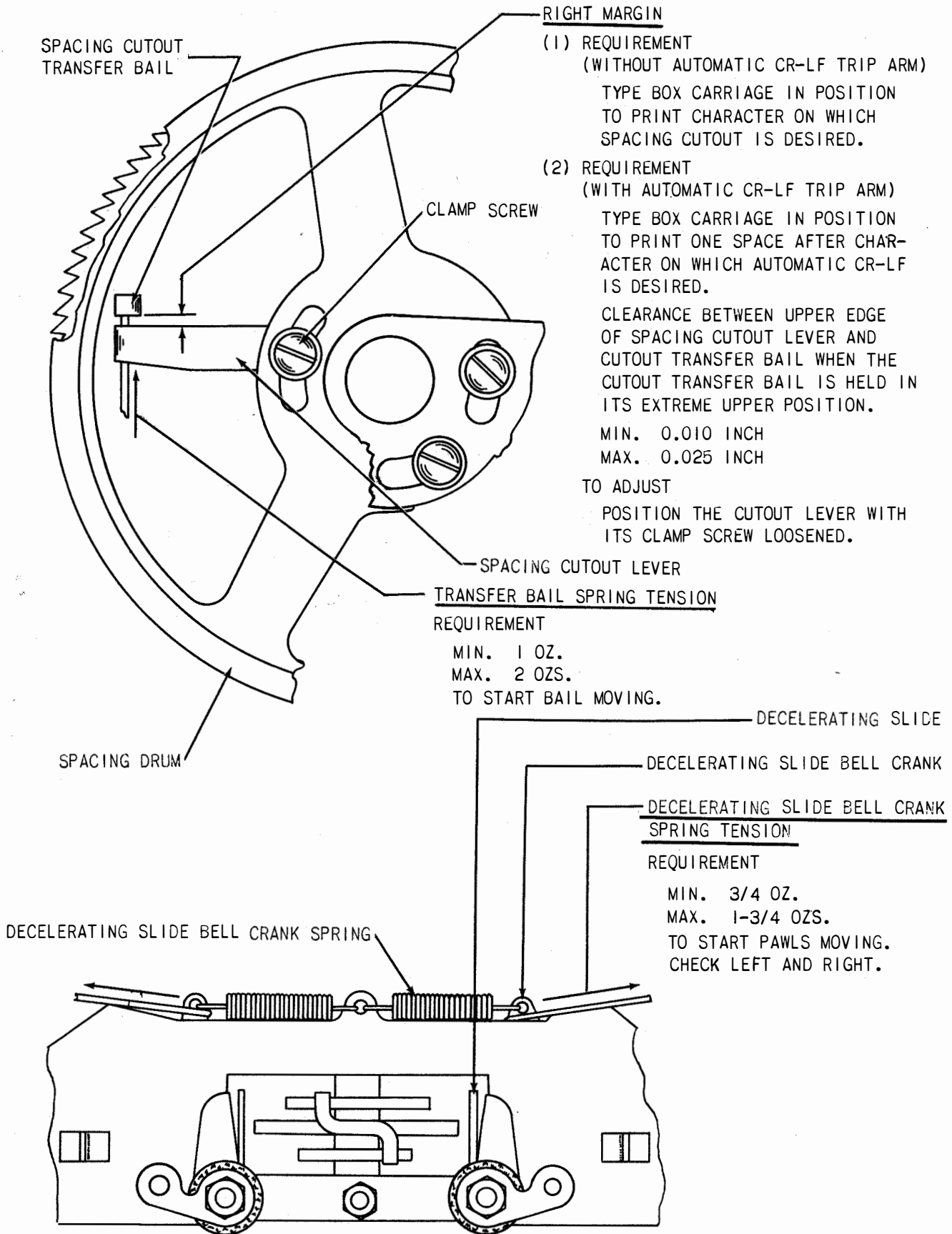
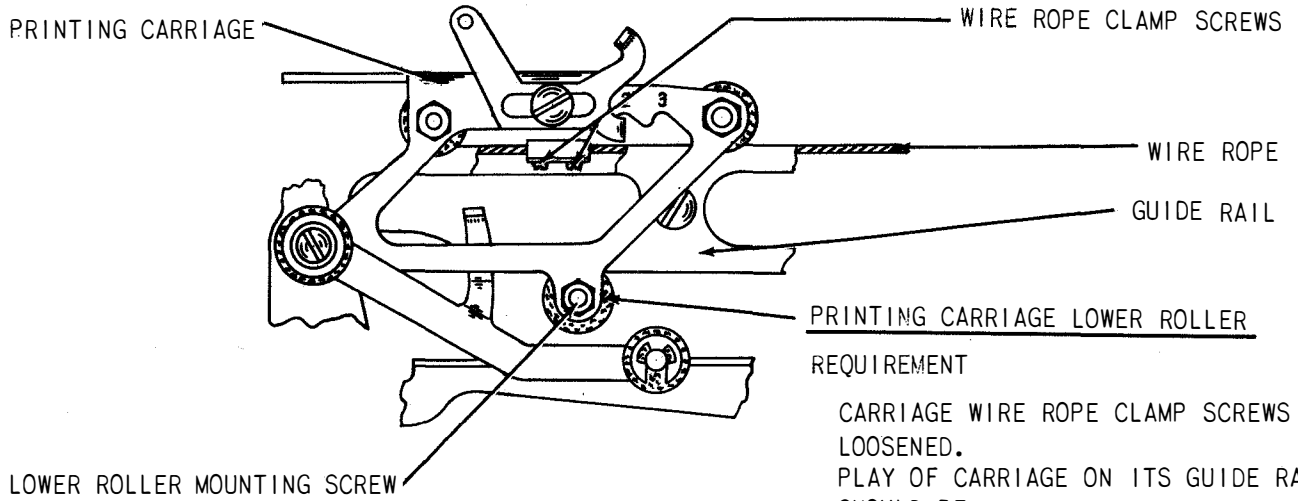


Figure 7-66. Automatic Typewriter, Right Margin and Decelerating Slide Mechanism





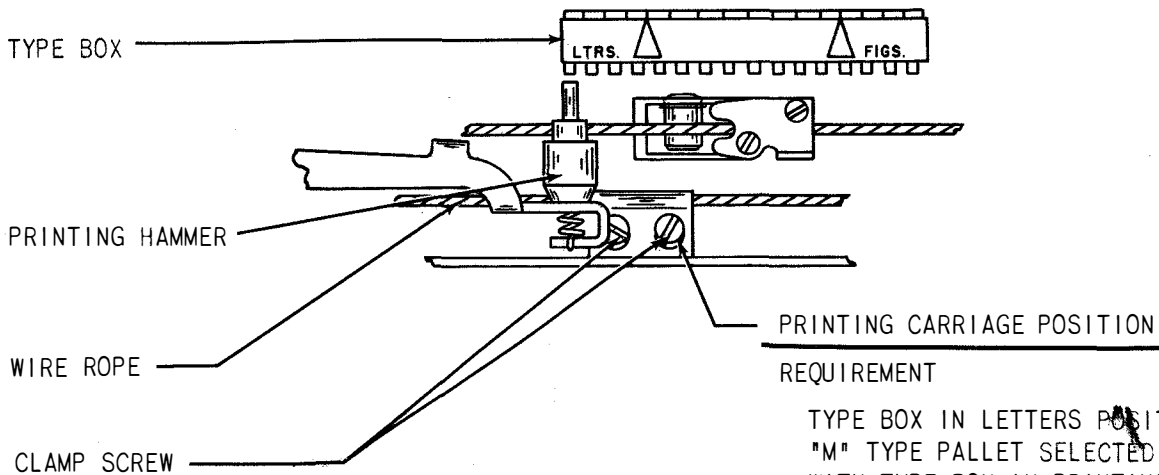
REQUIREMENT

CARRIAGE WIRE ROPE CLAMP SCREWS  
LOOSENED.  
PLAY OF CARRIAGE ON ITS GUIDE RAIL  
SHOULD BE

MINIMUM WITHOUT BIND  
THROUGHOUT FULL LENGTH OF GUIDE  
RAIL.

TO ADJUST

POSITION THE LOWER ROLLER WITH  
ITS MOUNTING SCREW LOOSENED.



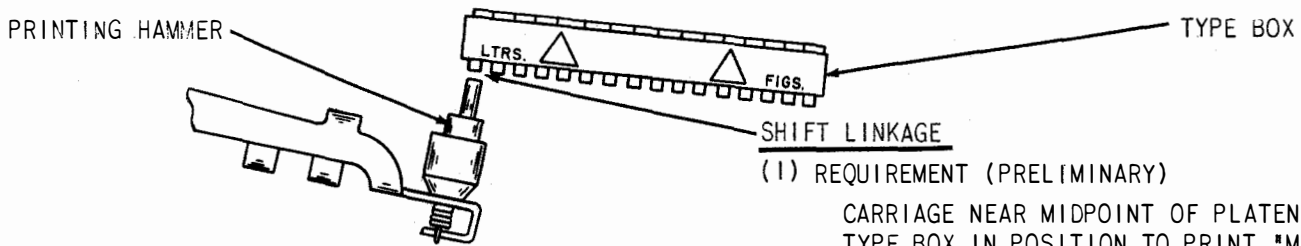
REQUIREMENT

TYPE BOX IN LETTERS POSITION.  
"M" TYPE PALLET SELECTED.  
WITH TYPE BOX IN PRINTING POSITION  
THE PRINTING HAMMER SHOULD BE IN  
ALIGNMENT WITH THE "M" TYPE PALLET.

TO ADJUST

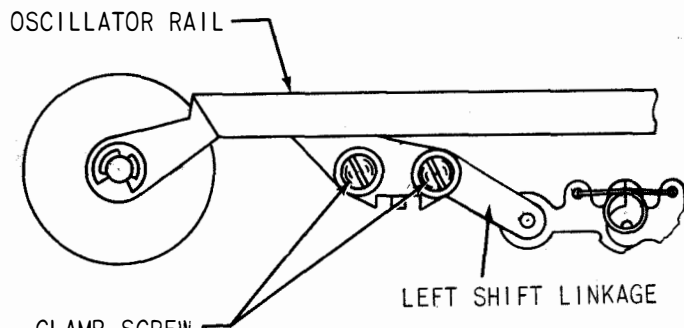
POSITION THE PRINTING CARRIAGE ON  
THE WIRE ROPE WITH ITS CLAMP  
SCREWS LOOSENED.

Figure 7-67. Automatic Typewriter, Printing Carriage



(1) REQUIREMENT (PRELIMINARY)

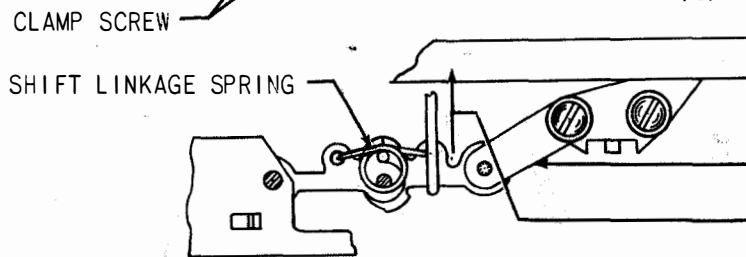
CARRIAGE NEAR MIDPOINT OF PLATEN.  
 TYPE BOX IN POSITION TO PRINT "M".  
 MANUALLY BUCKLE RIGHT SHIFT LINKAGE  
 AND SHIFT TYPE BOX TO LEFT. THE  
 PERIOD TYPE PALLET SHOULD BE IN  
 ALIGNMENT WITH THE PRINT HAMMER.



TO ADJUST

POSITION THE LEFT SHIFT LINKAGE ON  
 THE OSCILLATOR RAIL WITH ITS TWO  
 CLAMP SCREWS LOOSENED.

(2) REQUIREMENT (FINAL)



TYPWR OPERATING ALTERNATELY FROM  
 LETTERS TO FIGURES POSITIONS.  
 REFINE REQUIREMENT (1) IF  
 NECESSARY.

RIGHT SHIFT LINKAGE

SHIFT LINKAGE SPRING TENSION  
 REQUIREMENT

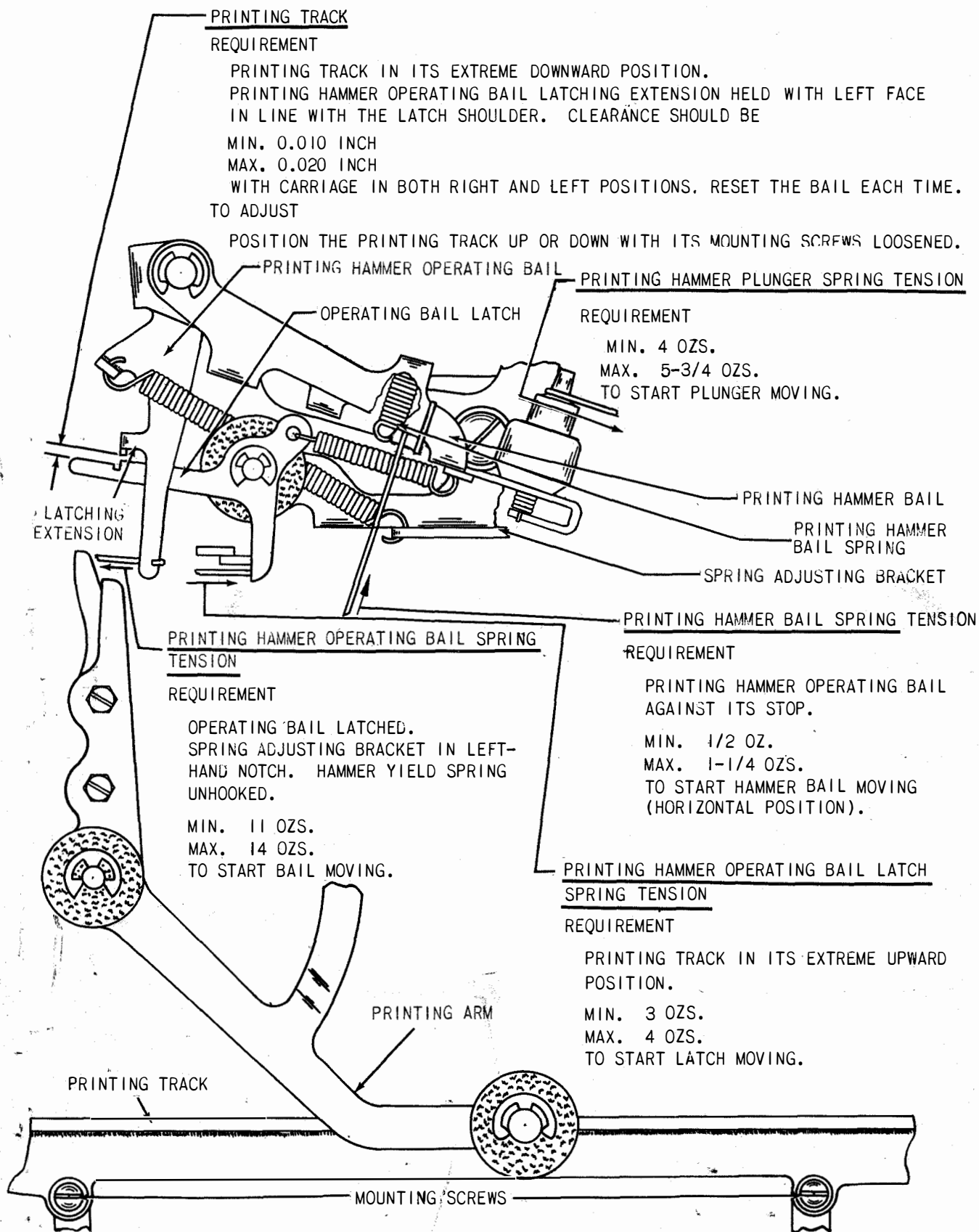
LINK IN STRAIGHT POSITION.

MIN. 7 OZS.

MAX. 12 OZS.

TO START EACH LINK MOVING.

Figure 7-68. Automatic Typewriter, Shift Mechanism



**Figure 7-69. Automatic Typewriter, Printing Mechanism**

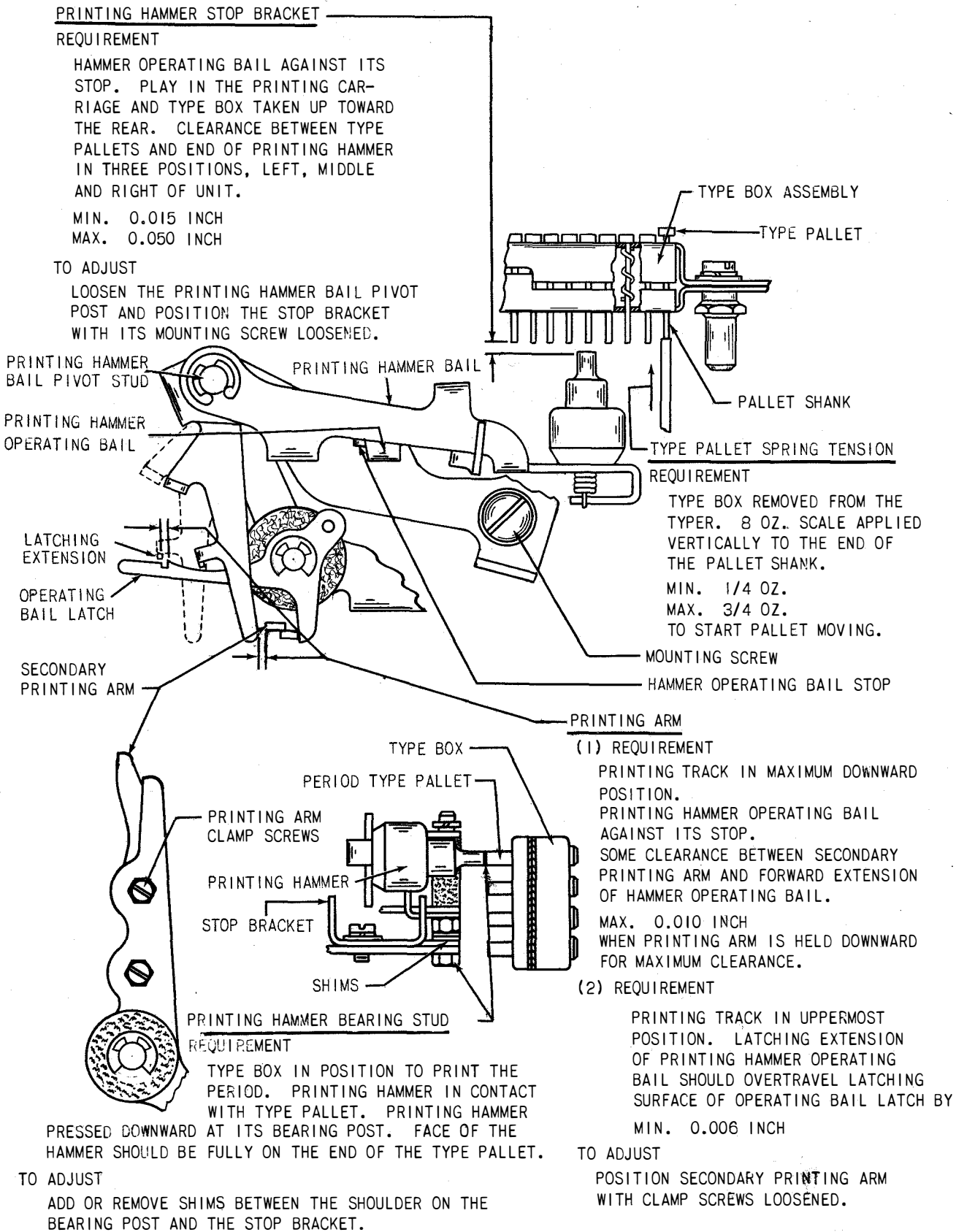
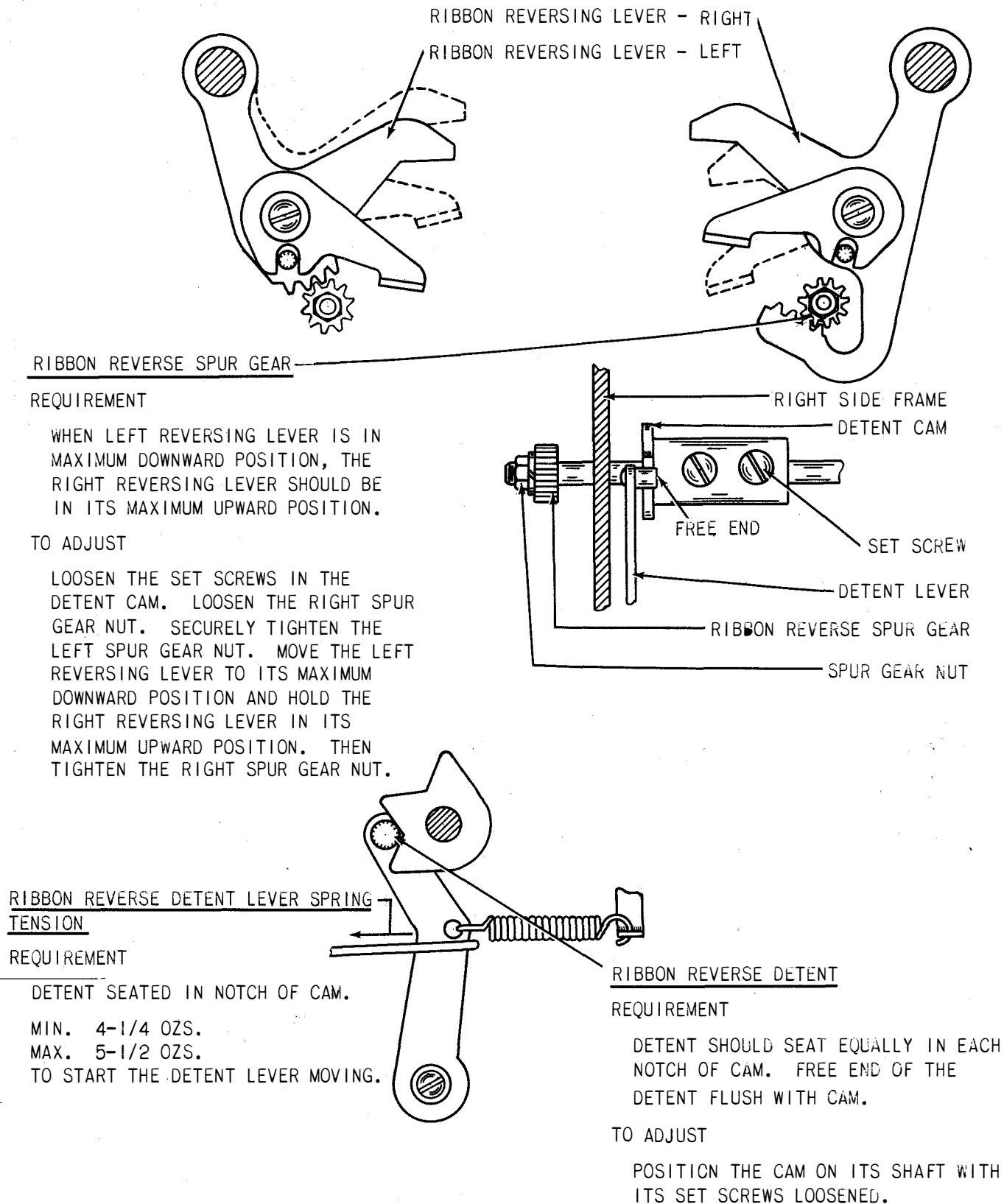


Figure 7-70. Automatic Typewriter, Printing Mechanism



**Figure 7-71. Automatic Typewriter, Ribbon Reverse Mechanism**

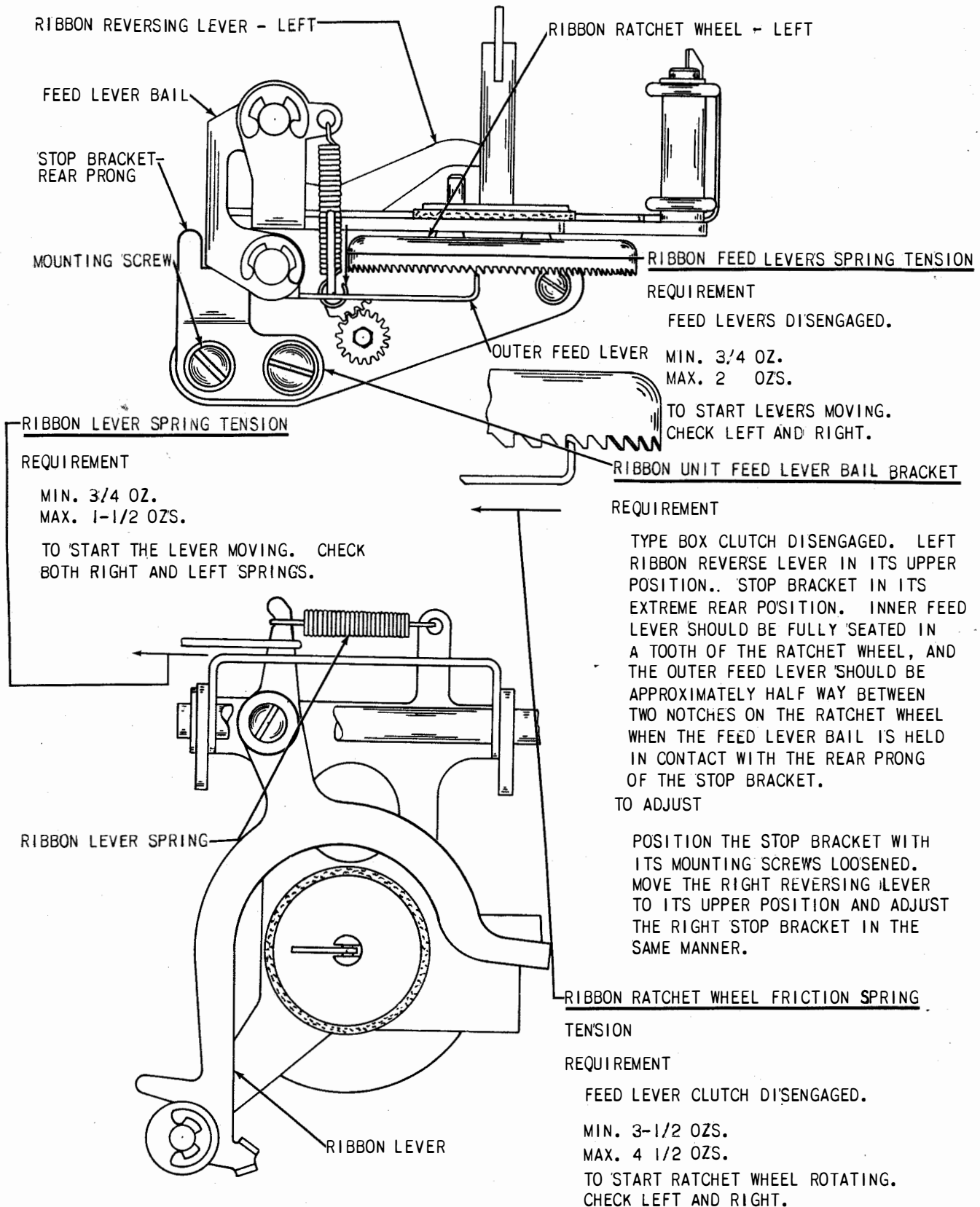


Figure 7-72. Automatic Typewriter, Ribbon Feed Mechanism

SHIFT CODE BAR OPERATING SLIDES

REQUIREMENT

FROM A STOP POSITION TRIP THE TYPE BOX CLUTCH AND ROTATE IT THROUGH APPROXIMATELY ONE-QUARTER CYCLE. HOOK LETTERS FUNCTION PAWL OVER ITS FUNCTION BAR. THE SHIFT CODE BAR SHOULD BE TO ITS RIGHT DETENTED POSITION BUT HAVE PERCEPTIBLE END PLAY. CHECK BY FEELING THE PLAY IN THE SHIFT CODE BAR. UNHOOK THE LETTERS FUNCTION PAWL. WITH FIGURES FUNCTION PAWL HOOKED OVER ITS FUNCTION BAR, THE SHIFT CODE BAR SHOULD BE MOVED TO ITS LEFT DETENTED POSITION AND HAVE PERCEPTIBLE END PLAY.

TO ADJUST

POSITION THE SLIDE PLATES TOWARD RIGHT OR LEFT WITH THEIR CLAMP NUTS LOOSENED.

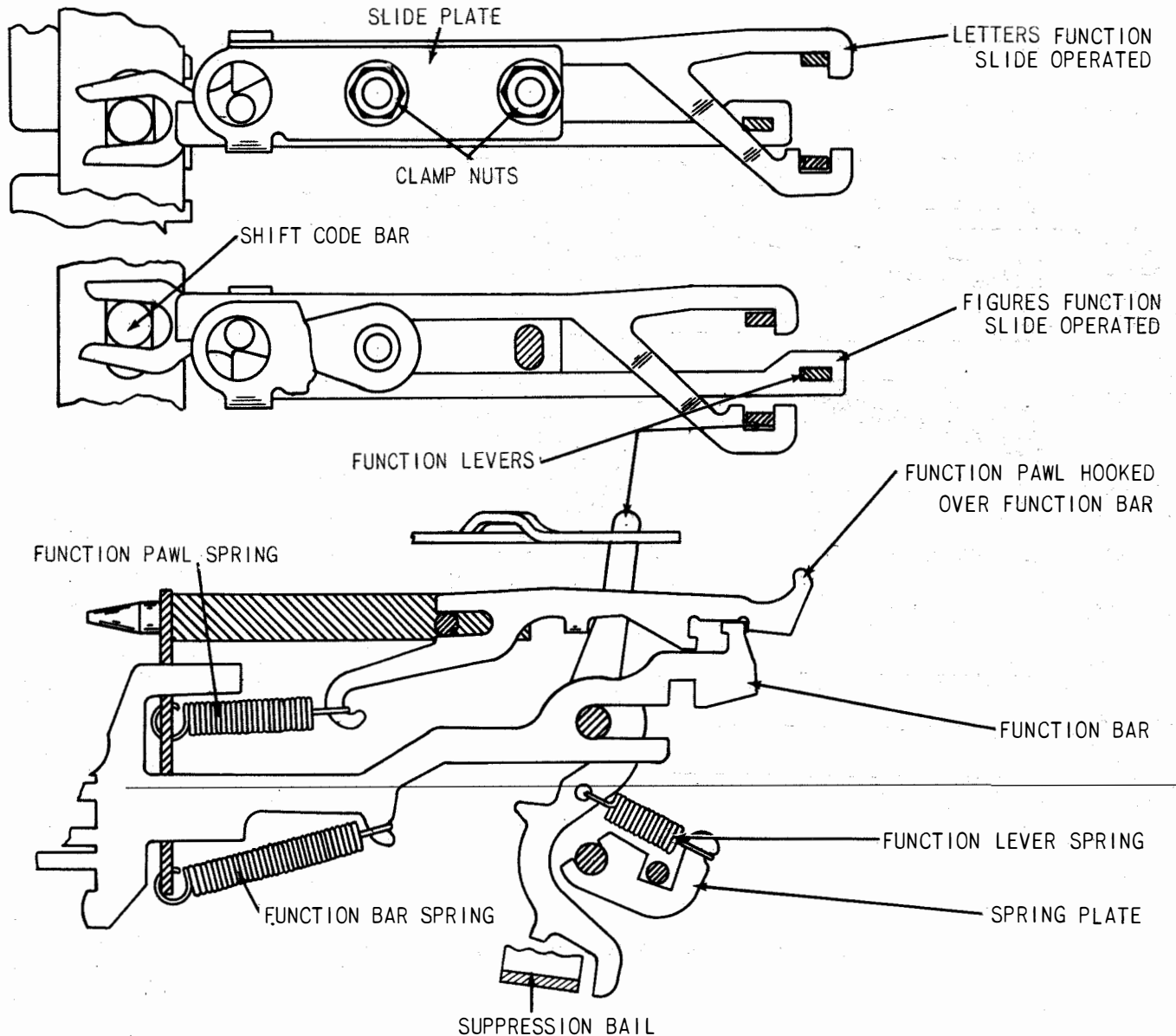


Figure 7-73. Automatic Typewriter, Shift Mechanism

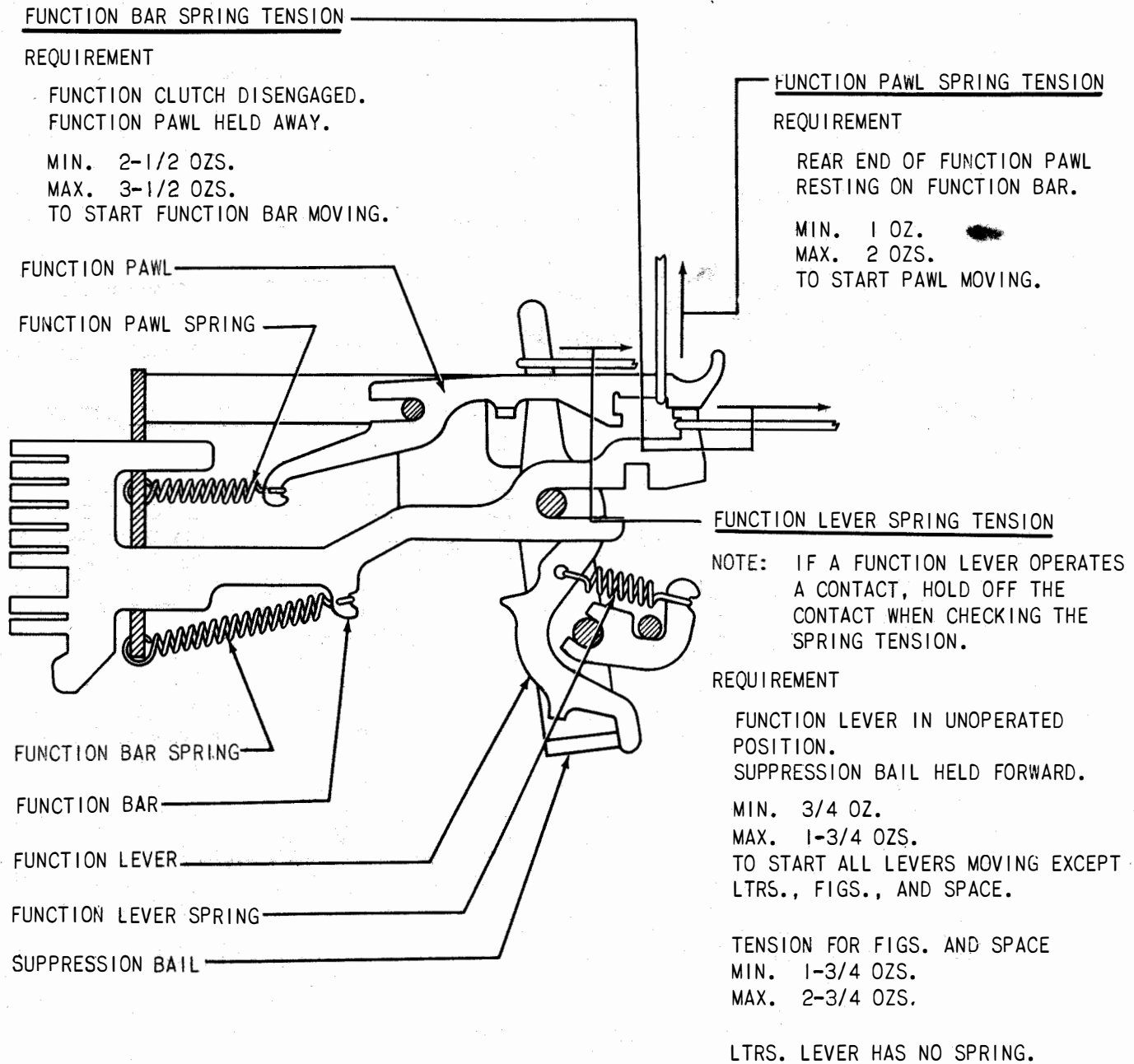


Figure 7-74. Automatic Typewriter, Function Box



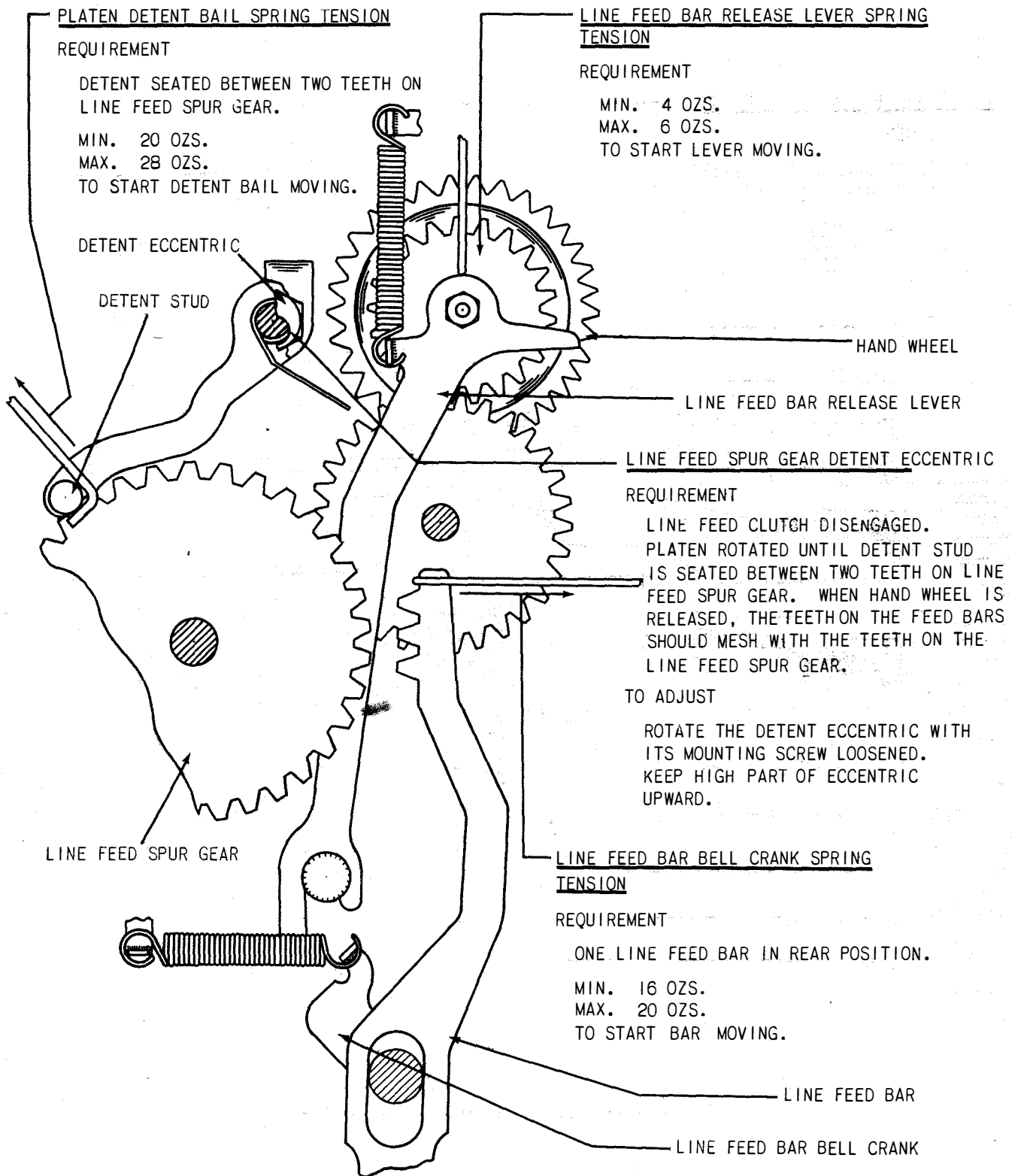
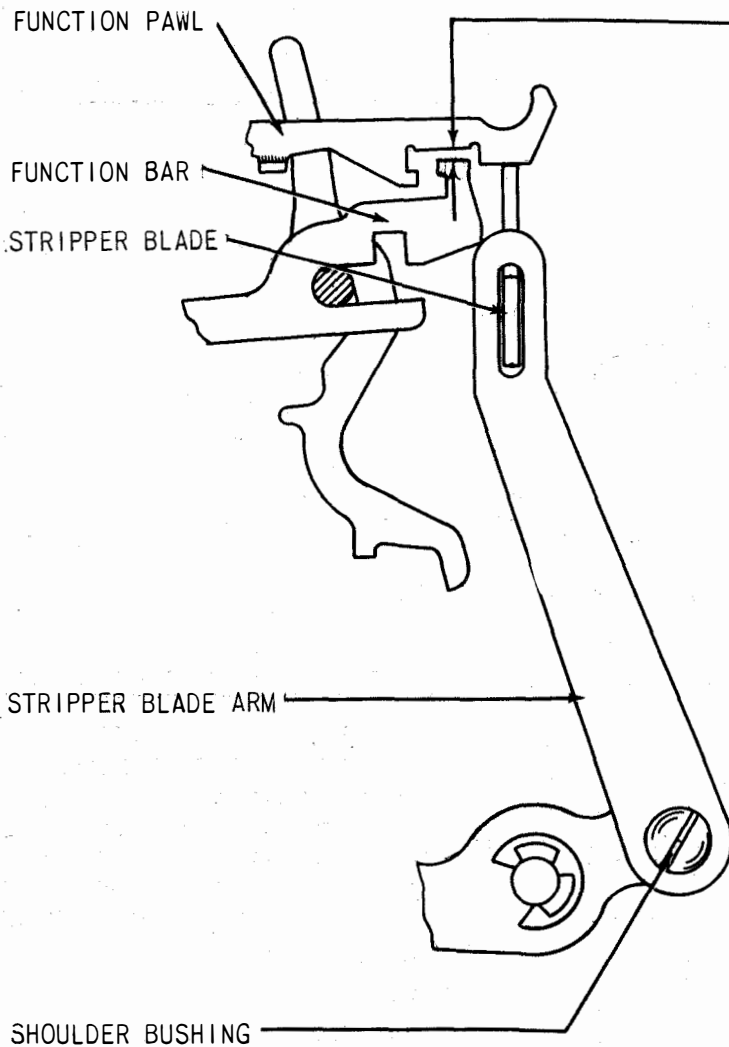


Figure 7-75. Automatic Typewriter, Line Feed Mechanism



FUNCTION STRIPPER BLADE ARMS

REQUIREMENT

TYPE BOX CLUTCH AND FUNCTION CLUTCH DISENGAGED. LEFT LINE FEED FUNCTION PAWL HELD IN ITS REAR POSITION AND RESTING IN THE UPPER EDGE OF THE STRIPPER BLADE. CLEARANCE BETWEEN UPPER EDGE OF FUNCTION BAIL AND LOWER SURFACE OF NOTCHED SECTION OF FUNCTION PAWL.

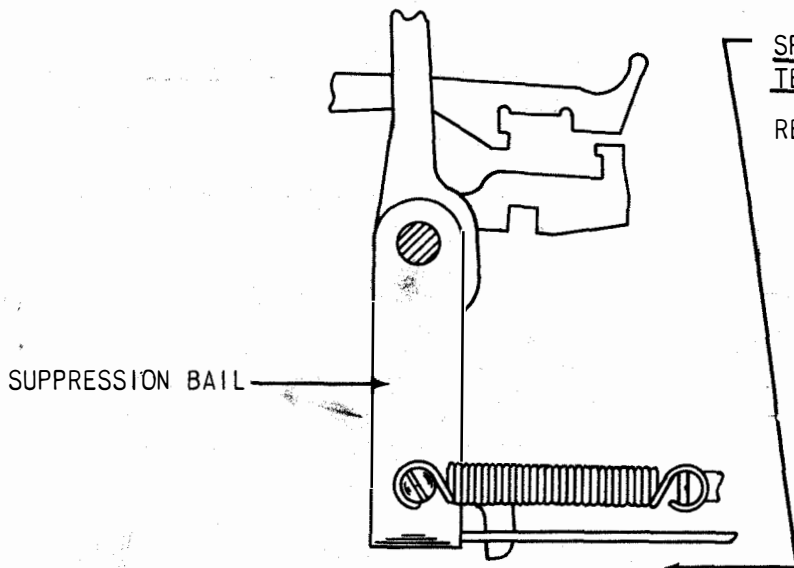
MIN. 0.060 INCH  
MAX. 0.075 INCH

THE LETTERS FUNCTION PAWL NEAR THE OPPOSITE END OF THE STRIPPER BLADE SHOULD HAVE THE SAME CLEARANCE.

TO ADJUST

POSITION THE SHOULDER BUSHING AT THE LOWER END OF THE RIGHT AND LEFT STRIPPER BLADE ARM WITH THE LOCK NUT LOOSENED.

Figure 7-76. Automatic Typewriter, Function Pawl Stripper Mechanism



SPACING SUPPRESSION BAIL SPRING TENSION

REQUIREMENT

SPACING SUPPRESSION BAIL IN REAR POSITION. SCALE APPLIED NEAR CENTER OF HORIZONTAL PORTION OF BAIL.

MIN. 1 OZ.  
MAX. 2-1/4 OZS.

TO START BAIL MOVING.

Figure 7-77. Automatic Typewriter, Spacing Suppression Mechanism

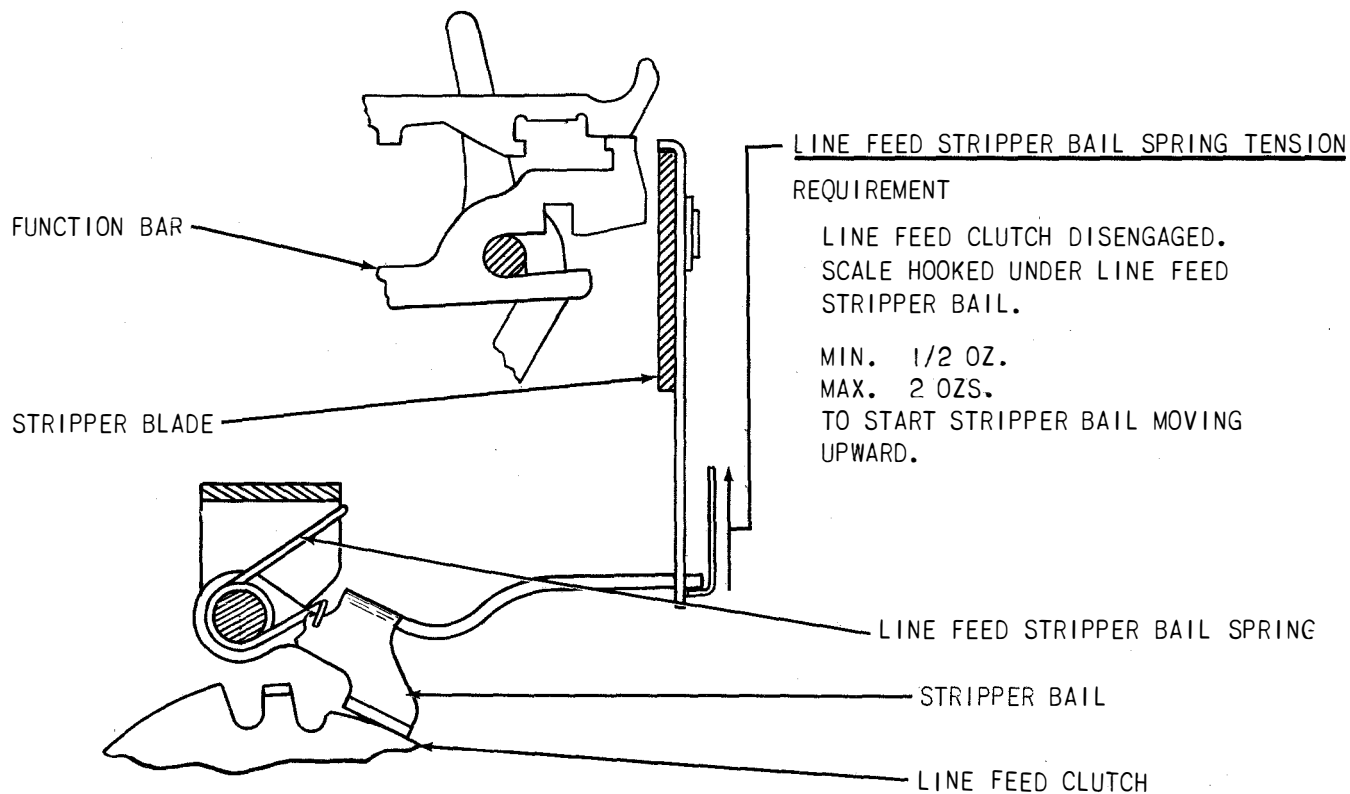
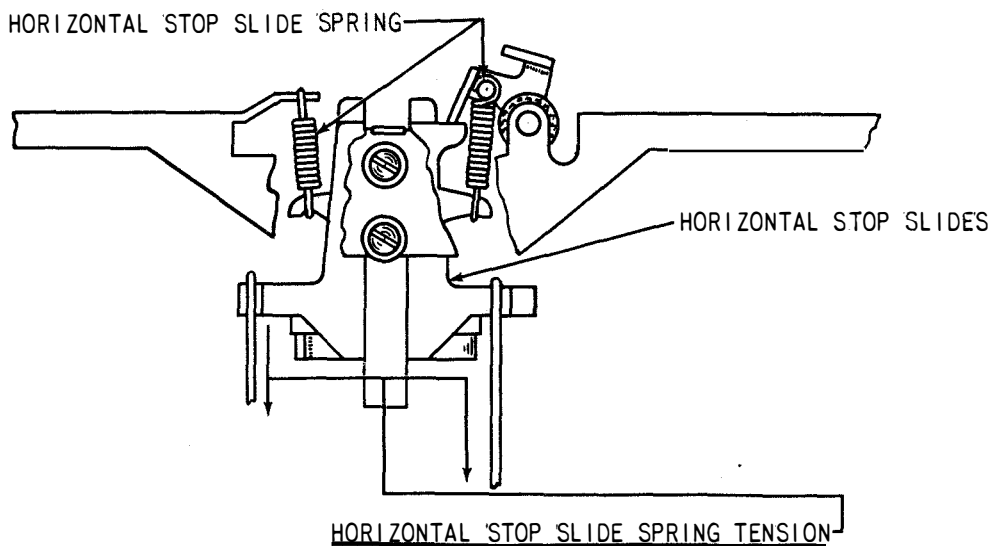


Figure 7-78. Automatic Typewriter, Function Pawl Stripper Mechanism



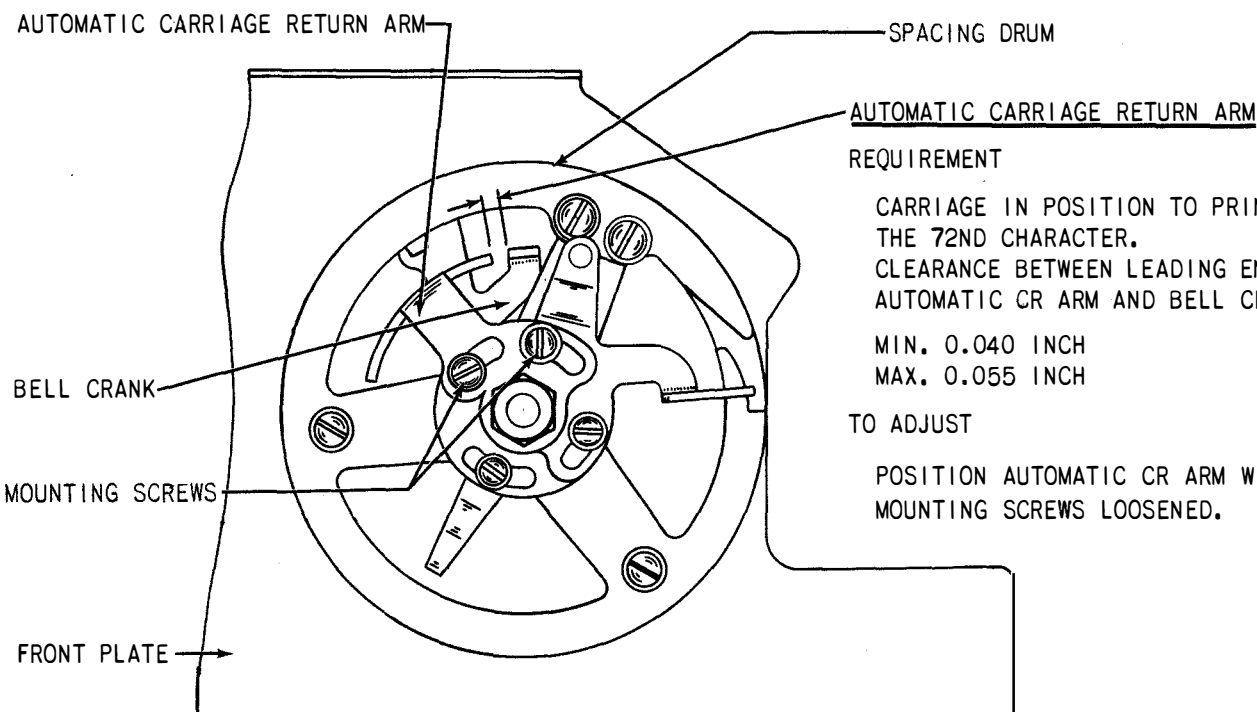
HORIZONTAL STOP SLIDE SPRING TENSION  
REQUIREMENT

CODE BARS IN MARKING POSITION (LEFT).  
TYPE BOX CLUTCH ROTATED 1/4 TURN FROM ITS STOP POSITION.  
HORIZONTAL MOTION DECELERATING SLIDES (FIG.7-57) HELD AWAY  
FROM HORIZONTAL STOP SLIDES.

MIN. 1/2 OZ.; MAX. 1 OZ. FOR UPPER AND LOWER SLIDES  
MIN. 2 OZS.; MAX. 3 OZS. FOR MIDDLE SLIDE

TO START SLIDE MOVING.

NOTE: WHEN CHECKING UPPER AND LOWER SLIDES, HOLD MIDDLE  
SLIDE 1/32 INCH FORWARD.



AUTOMATIC CARRIAGE RETURN ARM  
REQUIREMENT

CARRIAGE IN POSITION TO PRINT  
THE 72ND CHARACTER.  
CLEARANCE BETWEEN LEADING END OF  
AUTOMATIC CR ARM AND BELL CRANK.

MIN. 0.040 INCH  
MAX. 0.055 INCH

TO ADJUST

POSITION AUTOMATIC CR ARM WITH  
MOUNTING SCREWS LOOSENED.

Figure 7-79. Automatic Typewriter, Automatic Carriage Return Mechanism

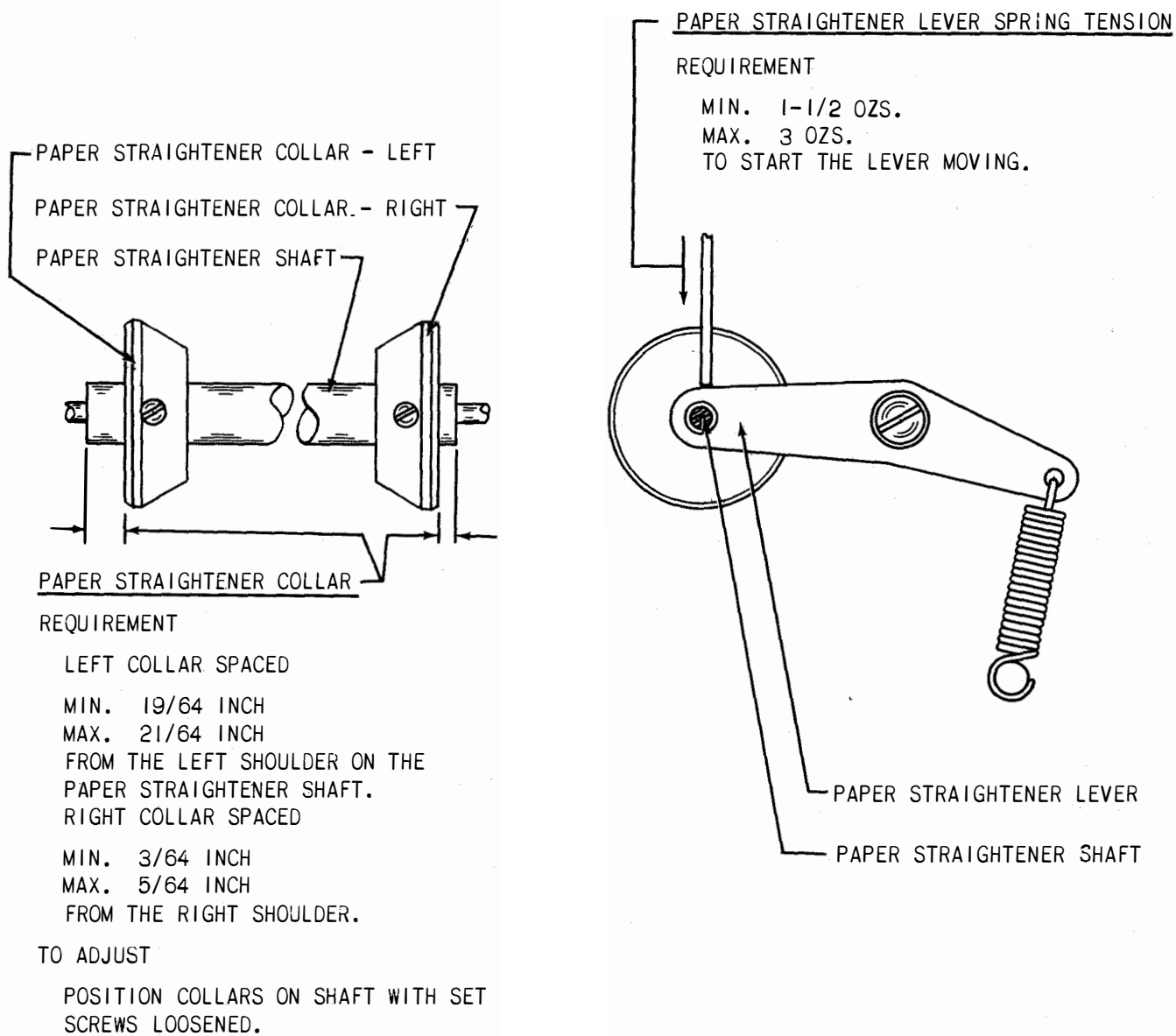


Figure 7-80. Automatic Typewriter, Paper Mechanism

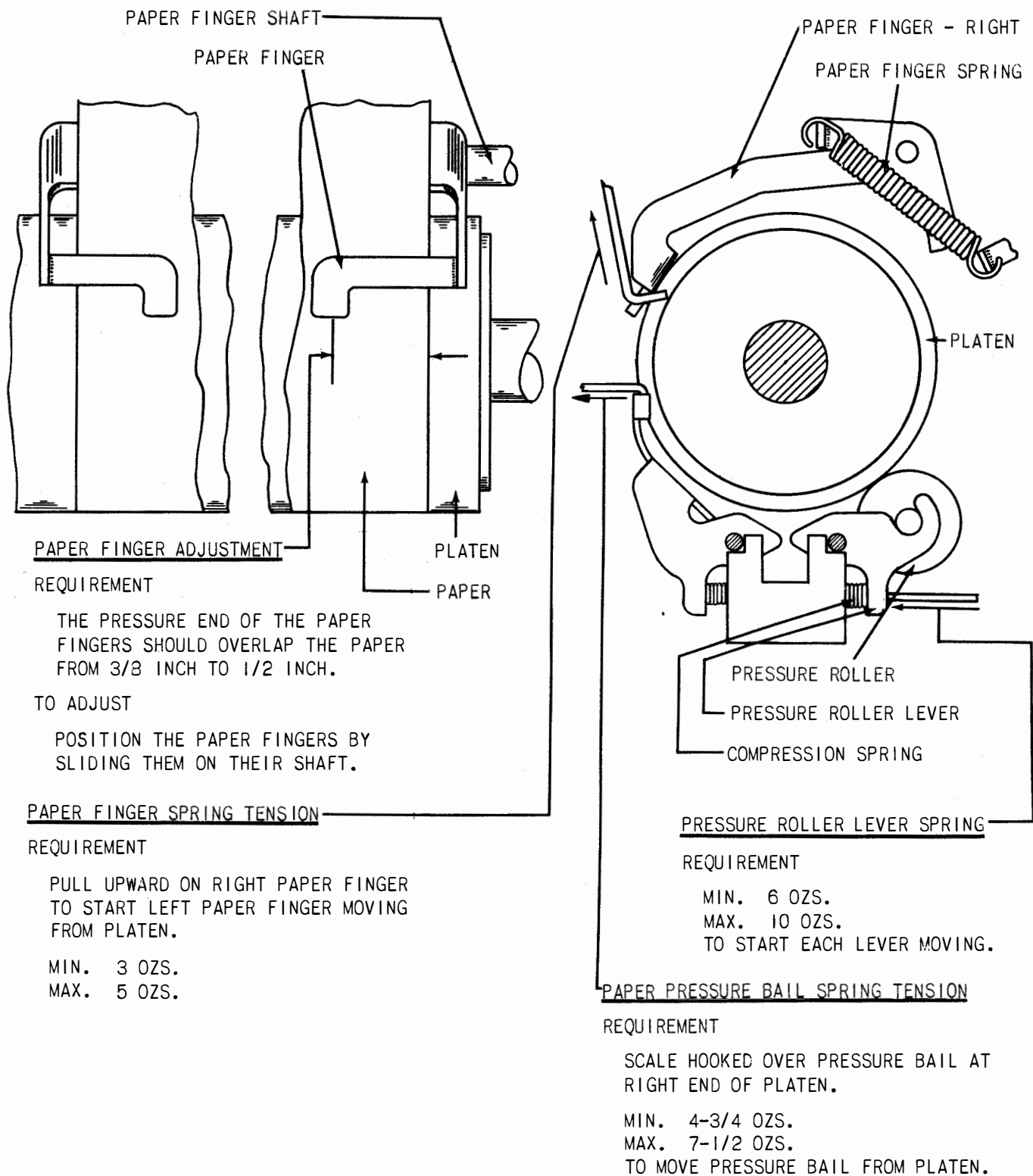


Figure 7-81. Automatic Typewriter, Paper Mechanism

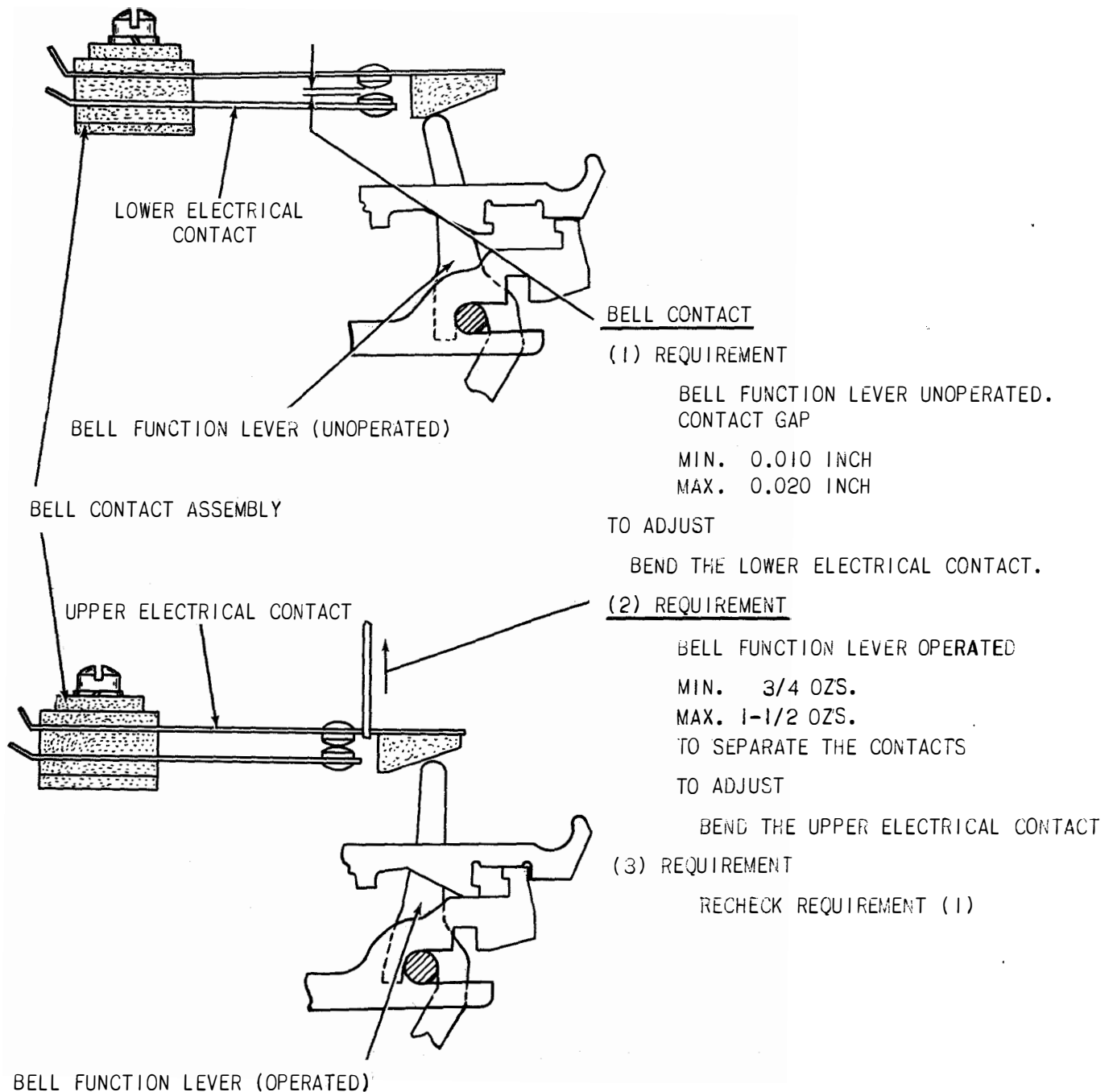
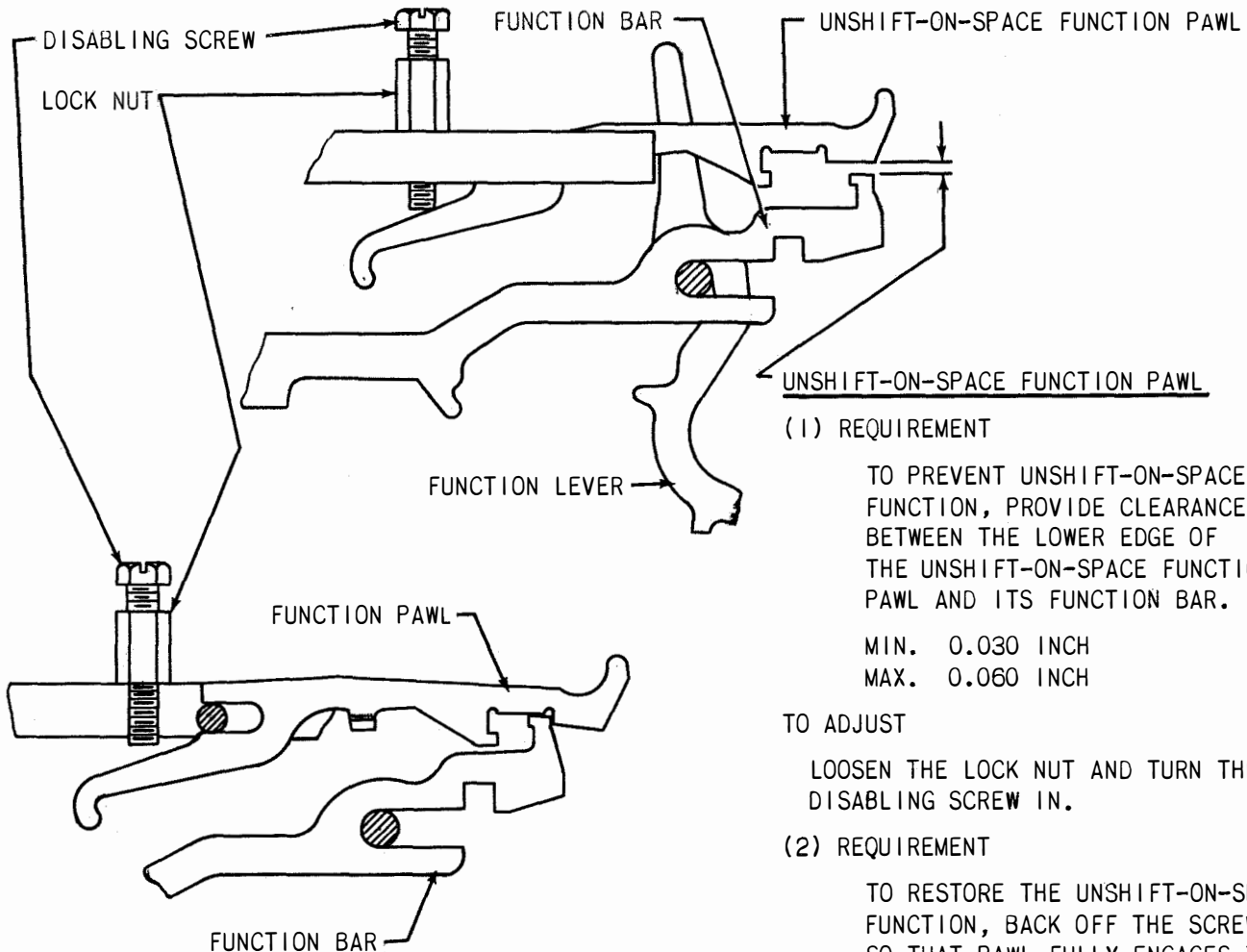


Figure 7-82. Automatic Typewriter, Bell Contact

**(1) REQUIREMENT**

TO PREVENT UNSHIFT-ON-SPACE FUNCTION, PROVIDE CLEARANCE BETWEEN THE LOWER EDGE OF THE UNSHIFT-ON-SPACE FUNCTION PAWL AND ITS FUNCTION BAR.

MIN. 0.030 INCH  
MAX. 0.060 INCH

**TO ADJUST**

LOOSEN THE LOCK NUT AND TURN THE DISABLING SCREW IN.

**(2) REQUIREMENT**

TO RESTORE THE UNSHIFT-ON-SPACE FUNCTION, BACK OFF THE SCREW SO THAT PAWL FULLY ENGAGES THE FUNCTION BAR. THEN CONTINUE TO TURN THE SCREW OUT ONE TO THREE TURNS.

**Figure 7-83. Automatic Typewriter, Unshift-On-Space Mechanism**



CODE BAR DETENT

NOTE: THE CODE BAR DETENTS NEED NOT BE CHECKED UNLESS THEY HAVE BEEN DISASSEMBLED OR UNLESS THERE IS REASON TO BELIEVE THAT THEY DO NOT FUNCTION PROPERLY. THE ADJUSTMENT CAN BE MADE MORE CONVENIENTLY WITH THE FRONT PLATE AND FUNCTION BOX REMOVED BUT MAY BE MADE WITHOUT THEIR REMOVAL. THE TWO METHODS FOLLOW.

(1) REQUIREMENT (FRONT PLATE AND FUNCTION BOX REMOVED)

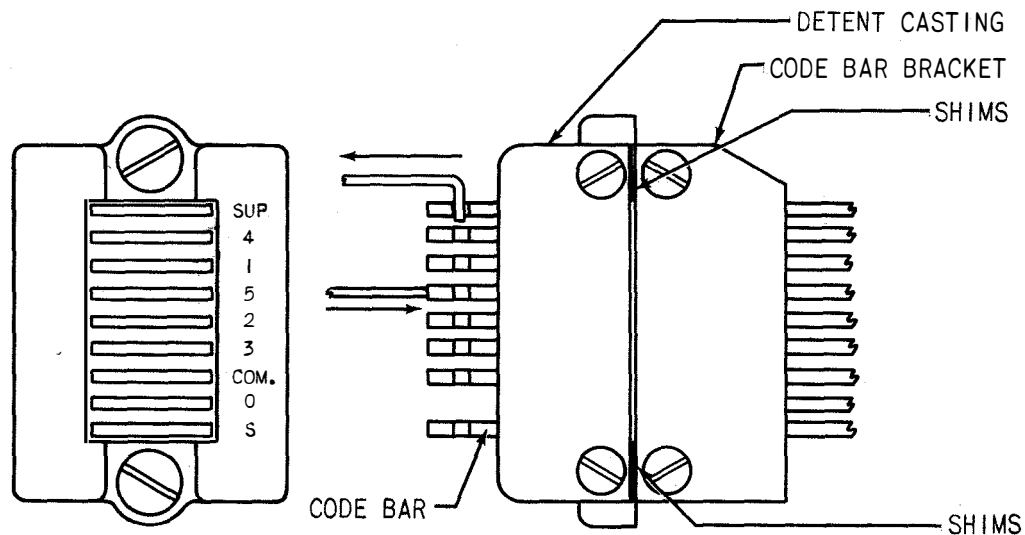
CODE BAR CLUTCH DISENGAGED. CODE BARS IN SPACING POSITION. PUSH AND PULL SCALE APPLIED ALTERNATELY TO CODE BAR.

MIN. 5 OZS.  
MAX. 10 OZS.

TO MOVE CODE BARS IN EITHER DIRECTION OVER DETENT.

TO ADJUST

EQUALIZE THE PRESSURE REQUIRED TO MOVE THE CODE BAR FROM ONE POSITION TO THE OTHER BY ADDING OR REMOVING SHIMS BETWEEN THE DETENT CASTING AND THE CODE BAR BRACKET.



(2) REQUIREMENT (FRONT PLATE AND FUNCTION BOX IN PLACE)

CODE BAR CLUTCH, TYPE BOX CLUTCH, AND FUNCTION CLUTCH DISENGAGED. REVERSING SLIDE ADJUSTING PLATE REMOVED. PUSH AND PULL SCALE APPLIED ALTERNATELY TO CODE BARS. PRESSURE REQUIRED TO MOVE CODE BAR FROM ONE POSITION TO ANOTHER AS FOLLOWS:

SUP, 1, 2, 3, AND COM. CODE BARS

MIN. 5 OZS.  
MAX. 10 OZS.

TO MOVE CODE BARS IN EITHER DIRECTION OVER DETENTS.

NOS. 4 AND 5 CODE BARS

5-1/2 OZS. TO 8-3/4 OZS. TO MOVE TO RIGHT (FRONT VIEW).

6-1/4 OZS. TO 9-1/2 OZS. TO MOVE TO LEFT.

NOTE THAT AUTOMATIC CR AND LF CODE BAR 0 HAS NO DETENT.

REMAKE THE REVERSING SLIDE ADJUSTING PLATE FIG. 7-56.

Figure 7-84. Automatic Typewriter, Code Bar Detent Mechanism

e. AC MOTOR PD-17/U.

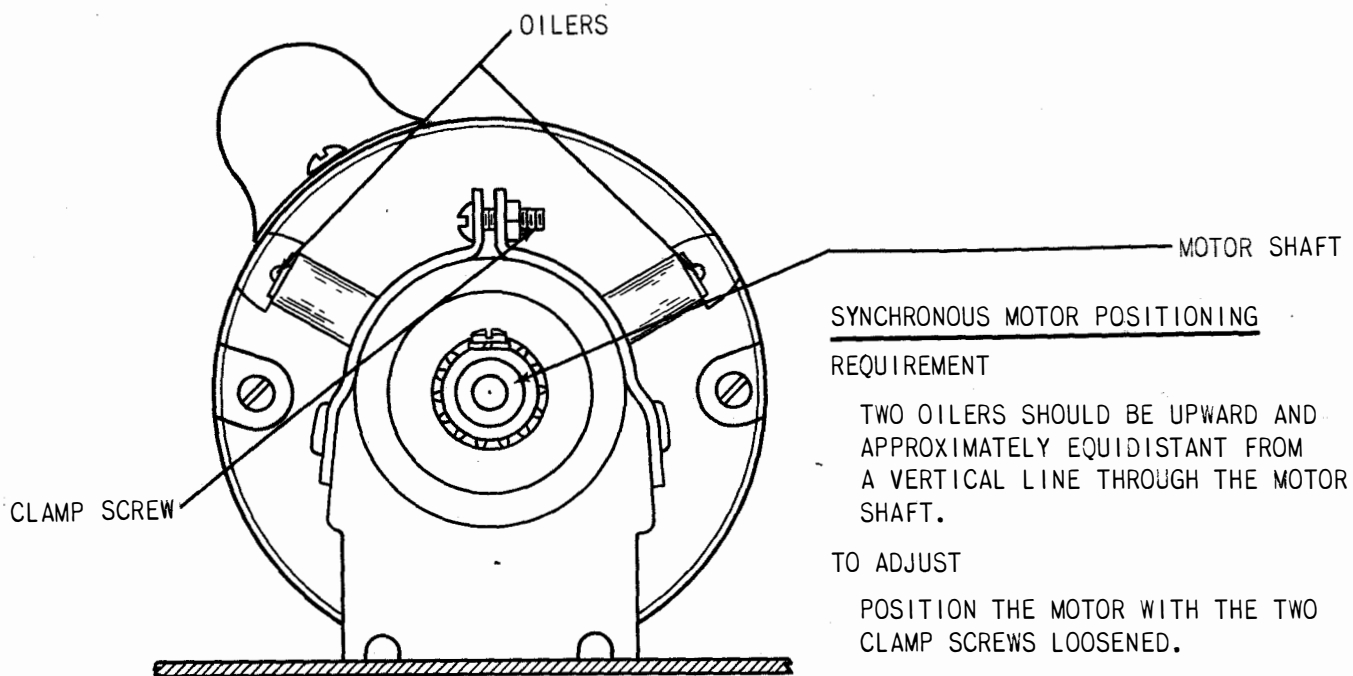


Figure 7-85. Motor Position

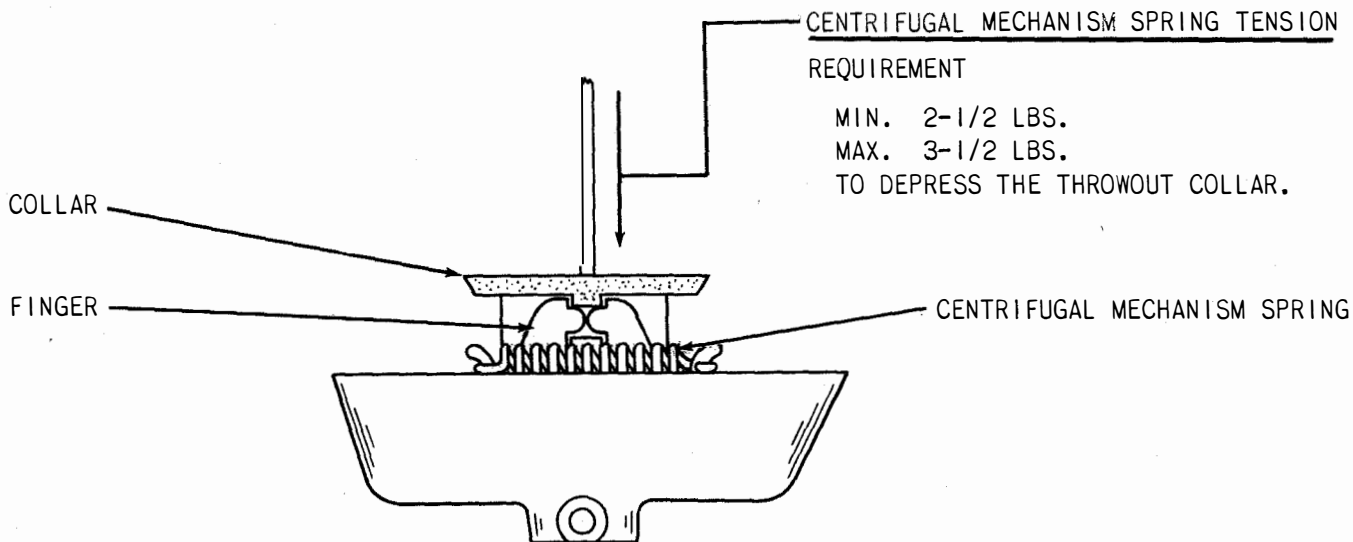
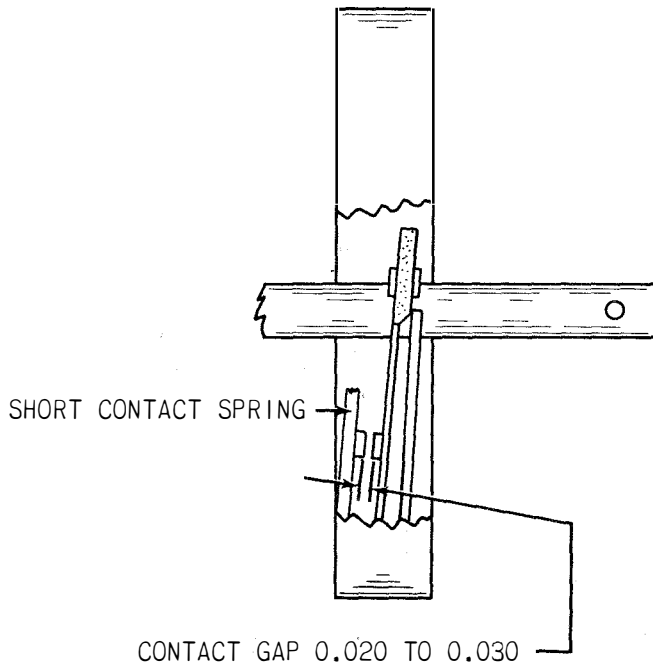


Figure 7-86. Centrifugal Mechanism



STARTING SWITCH CONTACT

(1) REQUIREMENT

THROWOUT COLLAR HELD AWAY FROM THE CONTACT SPRING INSULATORS. SOME CLEARANCE BETWEEN THE THROWOUT COLLAR AND THE INSULATORS THROUGH ONE COMPLETE REVOLUTION OF THE COLLAR.

TO ADJUST

BEND THE BACKSTOP WITH THE FLYWHEEL REMOVED.

(2) REQUIREMENT

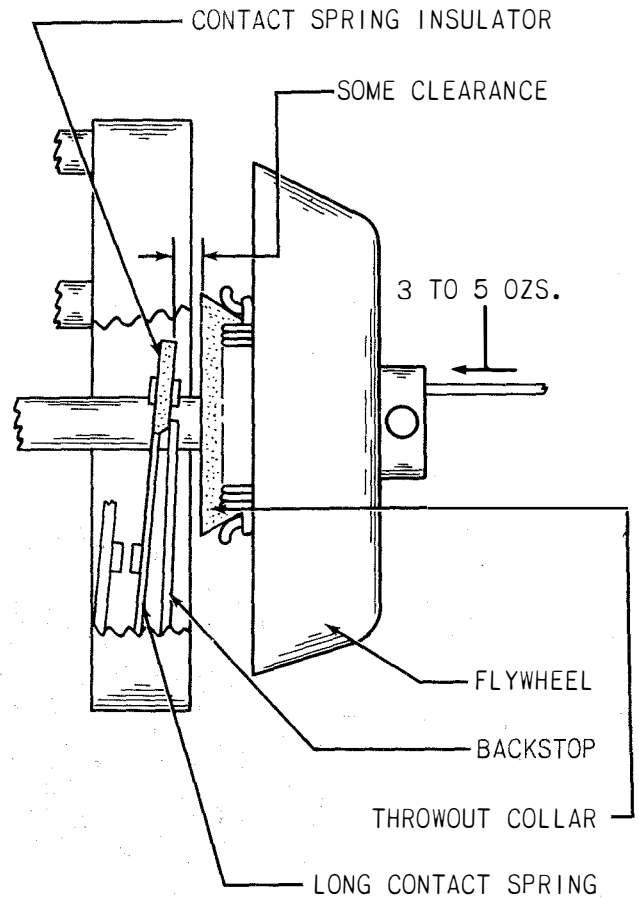
WITH THE CENTRIFUGAL MECHANISM REMOVED THERE SHOULD BE A CONTACT GAP OF

MIN. 0.020 INCH

MAX. 0.030 INCH

TO ADJUST

BEND THE SHORT CONTACT SPRING.



(3) REQUIREMENT

FLYWHEEL MOUNTING SCREW REMOVED AND THE FLYWHEEL FREE ON ITS SHAFT.

MIN. 3 OZS.

MAX. 5 OZS.

TO PUSH THE FLYWHEEL FLUSH WITH THE END OF THE SHAFT.

TO ADJUST

REMOVE THE FLYWHEEL WITH THE CENTRIFUGAL MECHANISM AND BEND THE LONG CONTACT SPRING. RE-CHECK REQUIREMENT (2).

Figure 7-87. Starting Switch

f. AC MOTOR PD-18/U.

A. GOVERNOR CONTACT

REQUIREMENT

THE CONTACTS SHOULD MEET SQUARELY AND NOT OVERLAP MORE THAN 0.010 INCH.

TO ADJUST

POSITION THE STATIONARY CONTACT AND CONTACT ARM WITH THE CLAMP SCREW AND POST LOOSENED.

B. GOVERNOR CONTACT BACKSTOP

REQUIREMENT

CLEARANCE BETWEEN THE MOVABLE CONTACT ARM AND ITS ECCENTRIC BACKSTOP.

MIN. 0.030 INCH

MAX. 0.050 INCH

TO ADJUST

ROTATE THE ECCENTRIC BACKSTOP WITH CLAMPING SCREW LOOSENED.

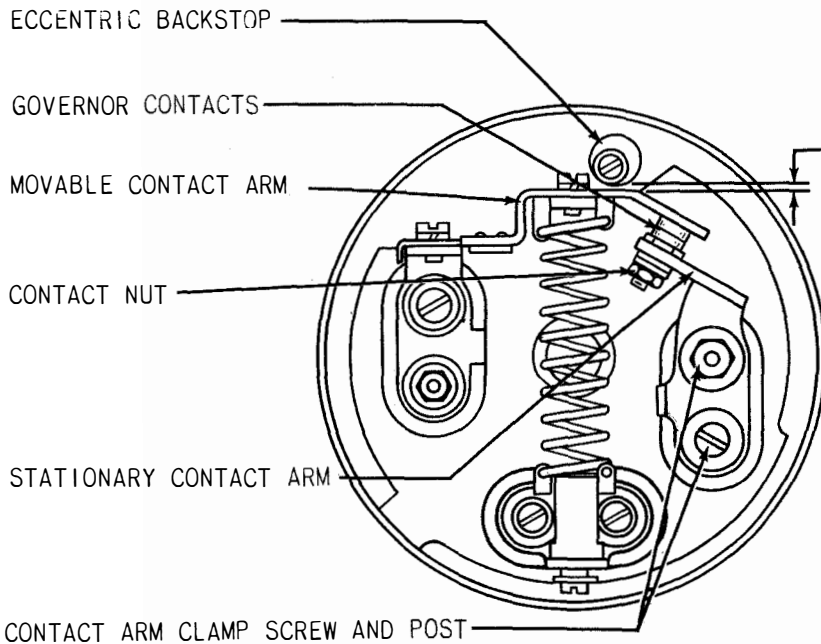


Figure 7-88. Motor Governor

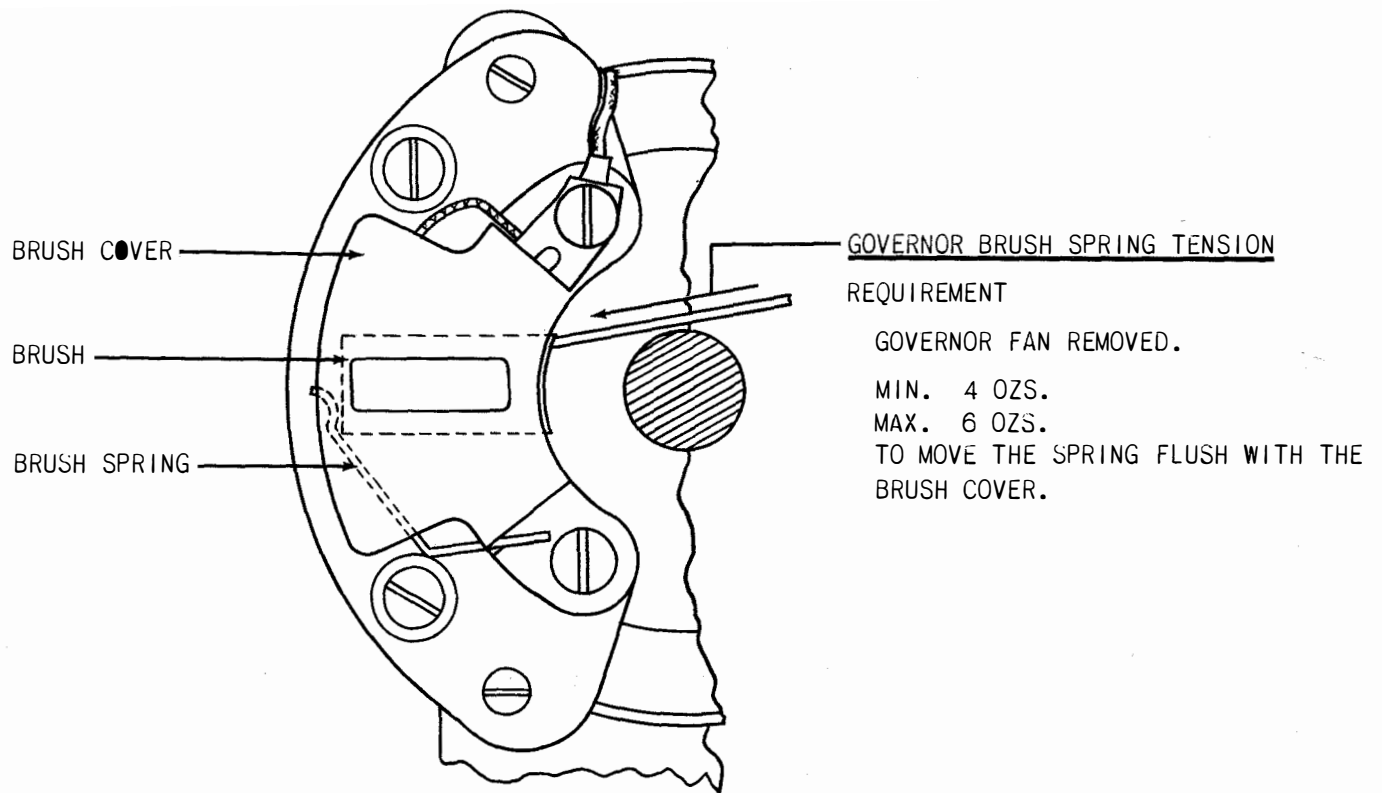
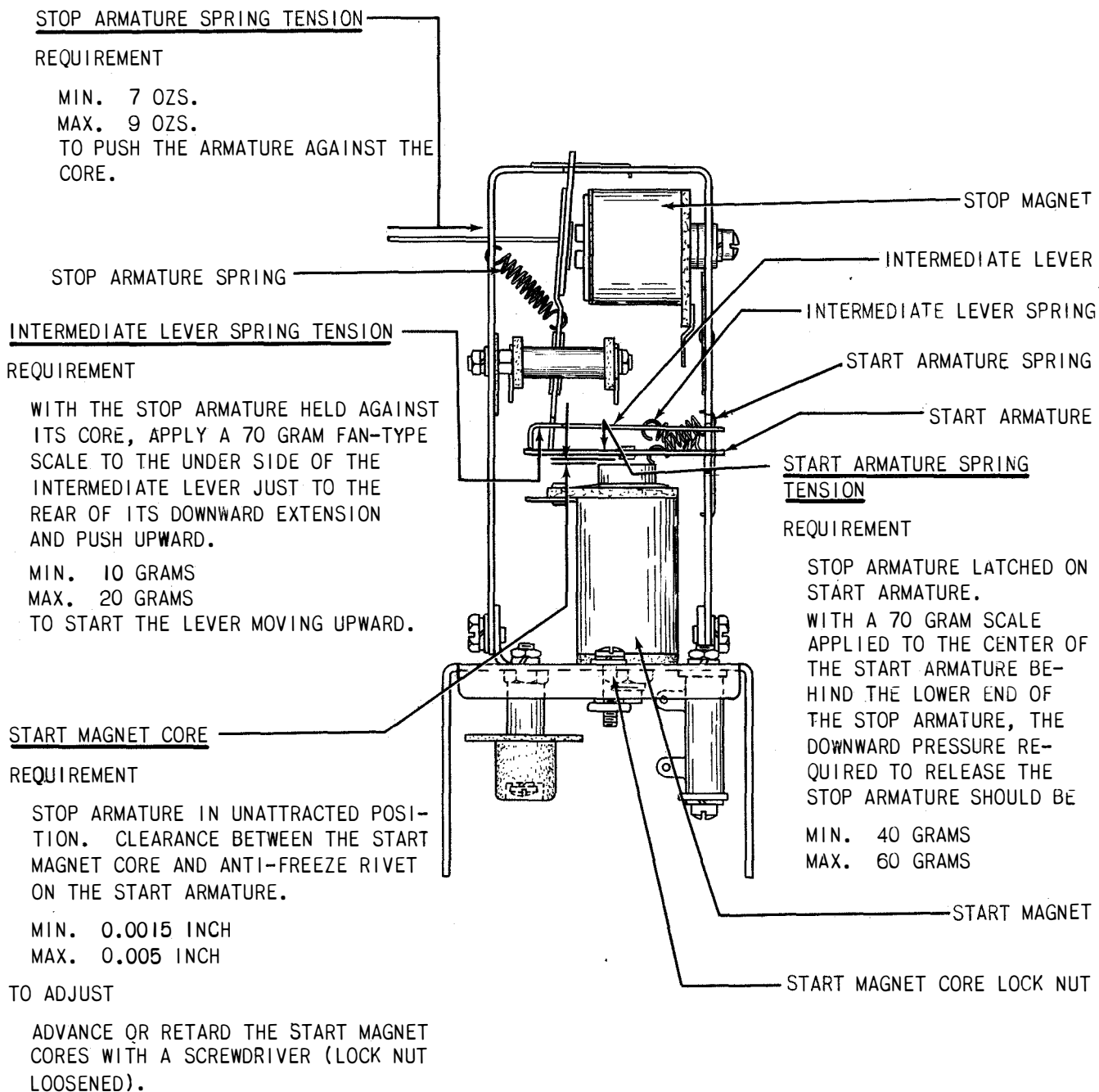


Figure 7-89. Motor Governor Brush

**g. POWER DISTRIBUTION PANEL SB-154/UG.**



**Figure 7-90. Motor Control Assembly**

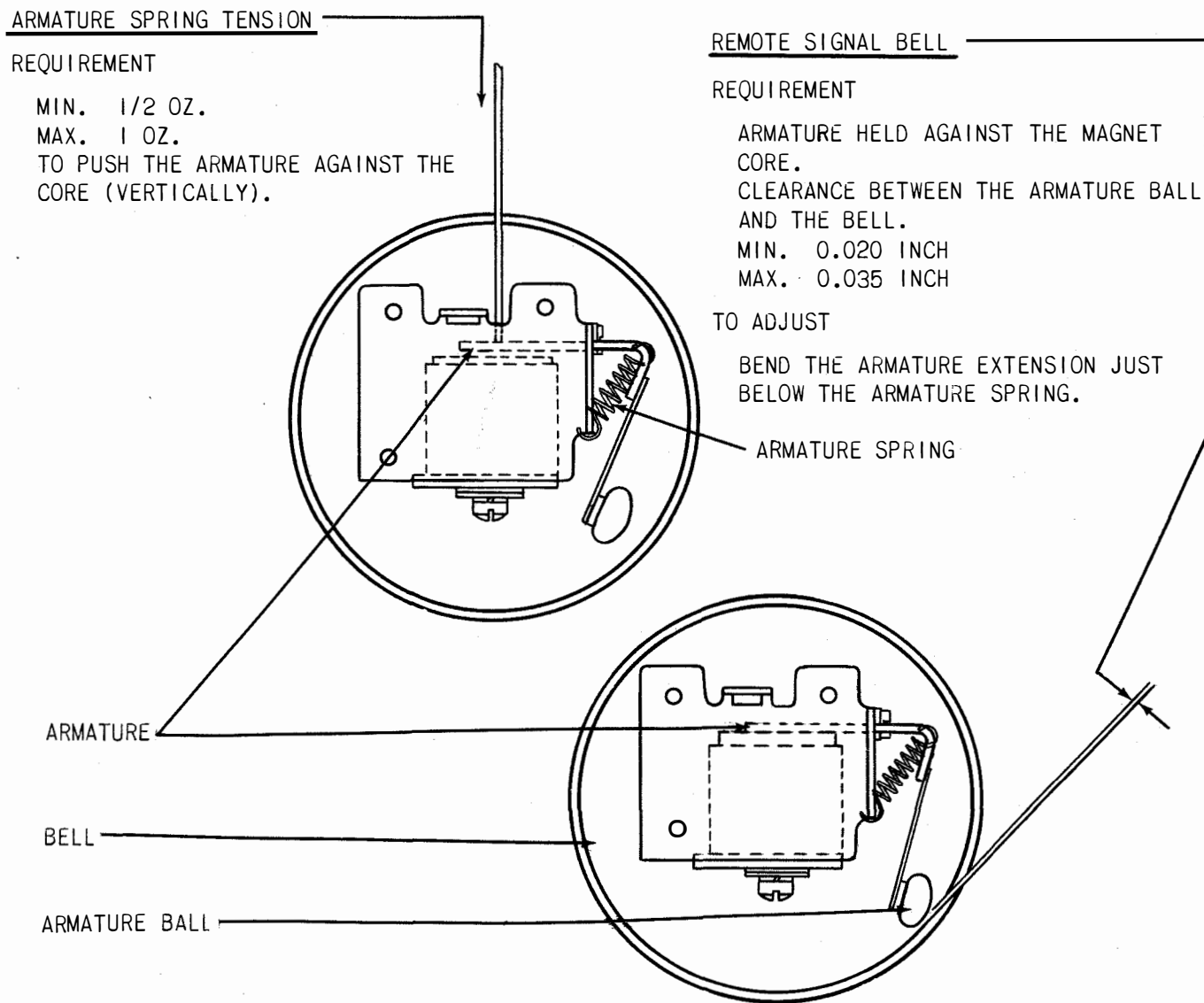
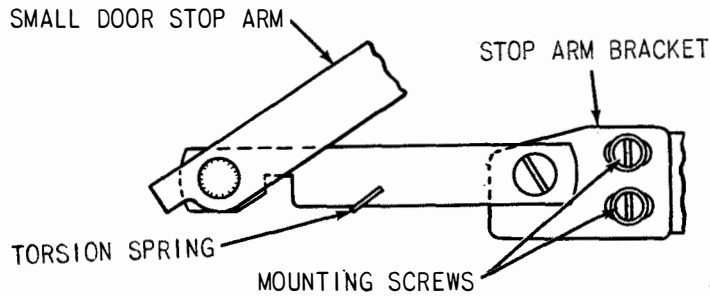


Figure 7-91. Remote Signal Bell

SMALL DOOR STOP ARM

## REQUIREMENT

STOP ARM SHOULD BE FREE OF BINDS WHEN DOOR IS OPENED OR CLOSED.

## TO ADJUST

LOOSEN THE STOP ARM BRACKET MOUNTING SCREWS. CLOSE THE DOOR. DISCONNECT THE TORSION SPRING. ALIGN STOP ARM FOR FREENESS AND TIGHTEN MOUNTING SCREWS WITH DOOR CLOSED. REPLACE TORSION SPRING.

WINDOW AND PAPER GUIDE

## (1) REQUIREMENT

THE BOTTOM EDGE OF THE PAPER GUIDE SHOULD BE FLUSH WITH THE BOTTOM EDGE OF THE WINDOW.

## TO ADJUST

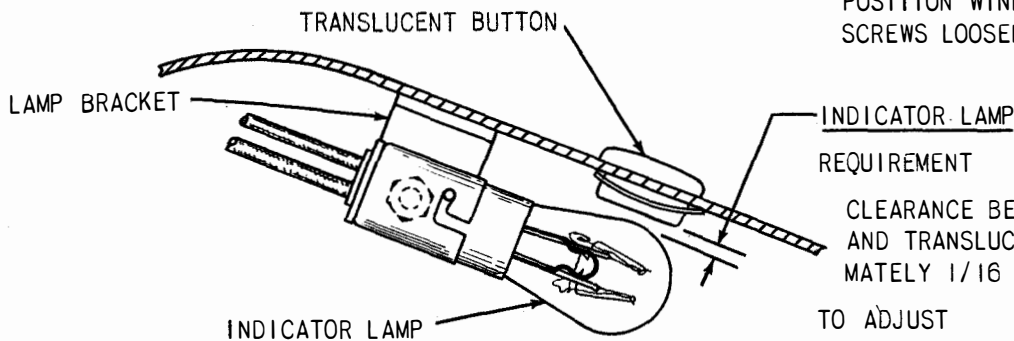
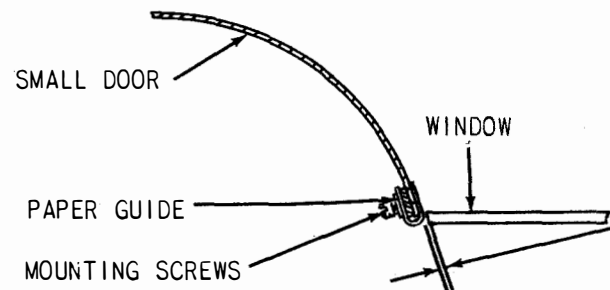
POSITION THE PAPER GUIDE WITH ITS MOUNTING SCREWS LOOSENED.

## (2) REQUIREMENT

THE SMALL DOOR SHOULD BARELY CLEAR THE WINDOW WHEN THE DOOR IS OPENED OR CLOSED.

## TO ADJUST

POSITION WINDOW WITH ITS RETAINER SCREWS LOOSENED.

INDICATOR LAMP

## REQUIREMENT

CLEARANCE BETWEEN INDICATOR LAMP AND TRANSLUCENT BUTTON APPROXIMATELY 1/16 INCH.

## TO ADJUST

POSITION LAMP HOLDER ON ITS BRACKET WITH ITS MOUNTING SCREWS LOOSENED.

Figure 7-92. Window and Accessories



i. **FINAL TEST.**—After all adjustments have been made, and the equipment is assembled, apply the operating tests indicated in section 3, paragraph 7. Refer to section 4, paragraph 9 for determining the orientation range. When a signal distortion test set is used for determining the receiving margins of the selector, and where the condition of the components is equivalent to that of new equipment, the range and distortion tolerances tabulated in Table 7-1 should be met.

**5. TOOLS.**

The tools listed in table 7-2 are required for maintenance of Teletypewriters TT-47/UG, TT-48/UG, TT-69/UG, and TT-70/UG but are not supplied as part of the equipments.

**6. EXPLODED ILLUSTRATIONS.**

The following figures illustrate the parts that comprise the various components of the equipment. They are grouped on a functional basis in so far as is practicable and are keyed to the parts list table 8-3, by their symbol designations. See paragraph 1.b. of this section for component numbering system. Figures are arranged as follows:

Component	Figure
Keyboard .....	7-94 to 7-105
Synchronous Motors .....	7-106 to 7-107
Governed Motor .....	7-107A to 7-108
Cabinet .....	7-109 to 7-110
Power Distribution Panel .....	7-111 to 7-112
Automatic Typewriter .....	7-113 to 7-134

**TABLE 7-1. SELECTOR MARGINS**

CURRENT	SPEED IN W. P. M.	POINTS RANGE WITH ZERO DISTORTION	PERCENTAGE OF MARKING AND SPACING BIAS TOLERATED	END DISTORTION TOLERATED WITH SCALE AT BIAS OPTIMUM SETTING
0.060 amp. (windings parallel)	60	60	42	37
0.060 amp. (windings parallel)	75	60	42	37
0.060 amp. (windings parallel)	100	72	40	35
0.020 amp. (windings series)	60	60	40	35
0.020 amp. (windings series)	75	60	40	35
0.020 amp. (windings series)	100	72	35	35

TABLE 7-2. LIST OF TOOLS

ITEM NO.	TELETYPE PART NO.	DESCRIPTION
1	125779	Wrench, socket
2	104986	Tuning Fork—120 vps
3	82711	Scale, spring—64 oz.
4	110444	Scale, spring—32 oz.
5	110443	Scale, spring—8 oz.
6	Western Electric No. 68C	70-gram Scale
7	100982	Screwdriver, screw-holding
8	110442	Screwdriver
9	151382	Screwdriver
10	151384	Screw Starter
11	94644	Screwdriver, off-set
12	94645	Screwdriver, off-set
13	151392	Tweezers
14	151383	Key Lever Remover
15	151372	Wrench, open-socket— $\frac{3}{16}$ inch
16	151373	Wrench, open-socket— $\frac{1}{4}$ inch
17	151374	Wrench, open-socket— $\frac{5}{16}$ inch
18	151375	Wrench, open-socket— $\frac{3}{8}$ inch
19	73408	Magnifier with case
20	117781	Set of 28 Gauges with case
21	88993	Burnisher, contact
22	151377	Gauge
23	125758	File, contact
24	151394	Brush, typewriter—toothbrush style
25	5576	Contact Bender
26	73404	Tommy
27	150988	Handwheel
28	151351	Spring Hook, pull
29	75503	Spring Hook, push
30	75765	Spring Hook, pull
31	151959	Spring Hook, pull
32	151379	Gauge

TABLE 7-3. WINDING DATA

DESIGNATION SYMBOL	TELETYPE PART NO.	MFG. PART NO.	WINDING	WIRE SIZE	TURNS	D-C RES. OHMS	HIPOT A-C VOLTS	REMARKS
E-756 E-1103	247M	CTT 247M	Single	No. 34	4000	190	500	115 V. a-c magnet
E-1108A E-1108B	246M	CTT 246M	Single	No. 33	3600	132	500	115 V. d-c magnet
E-1304 E-1305	245M	CTT 245M	Single	No. 33	3600	132	500	115 V. d-c magnet
K-1101	151808	CARE MR11A	Single	No. 39	600	1250	500	115 V. a-c magnet

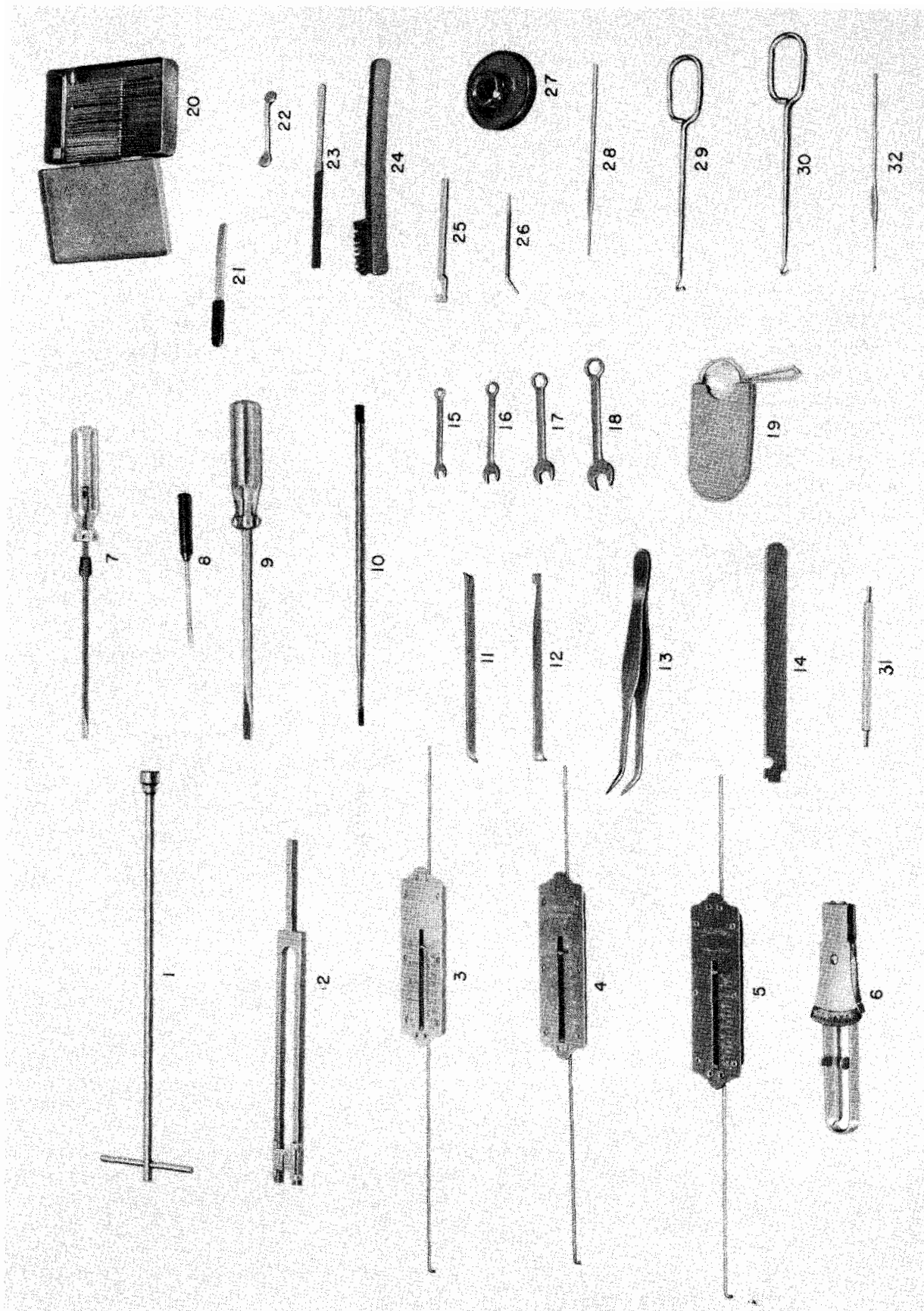


Figure 7-93. Tools

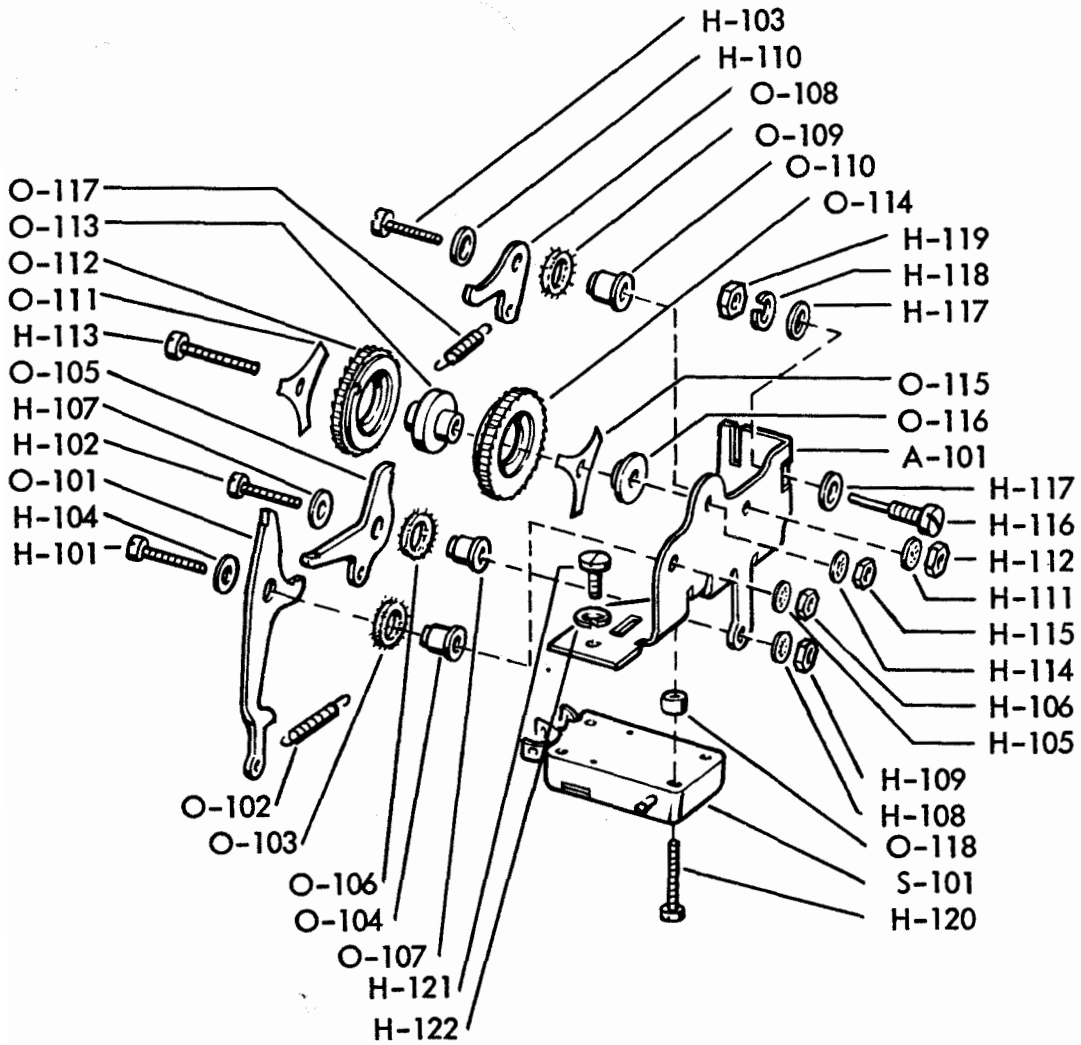


Figure 7-94. Keyboard, Time Delay Mechanism

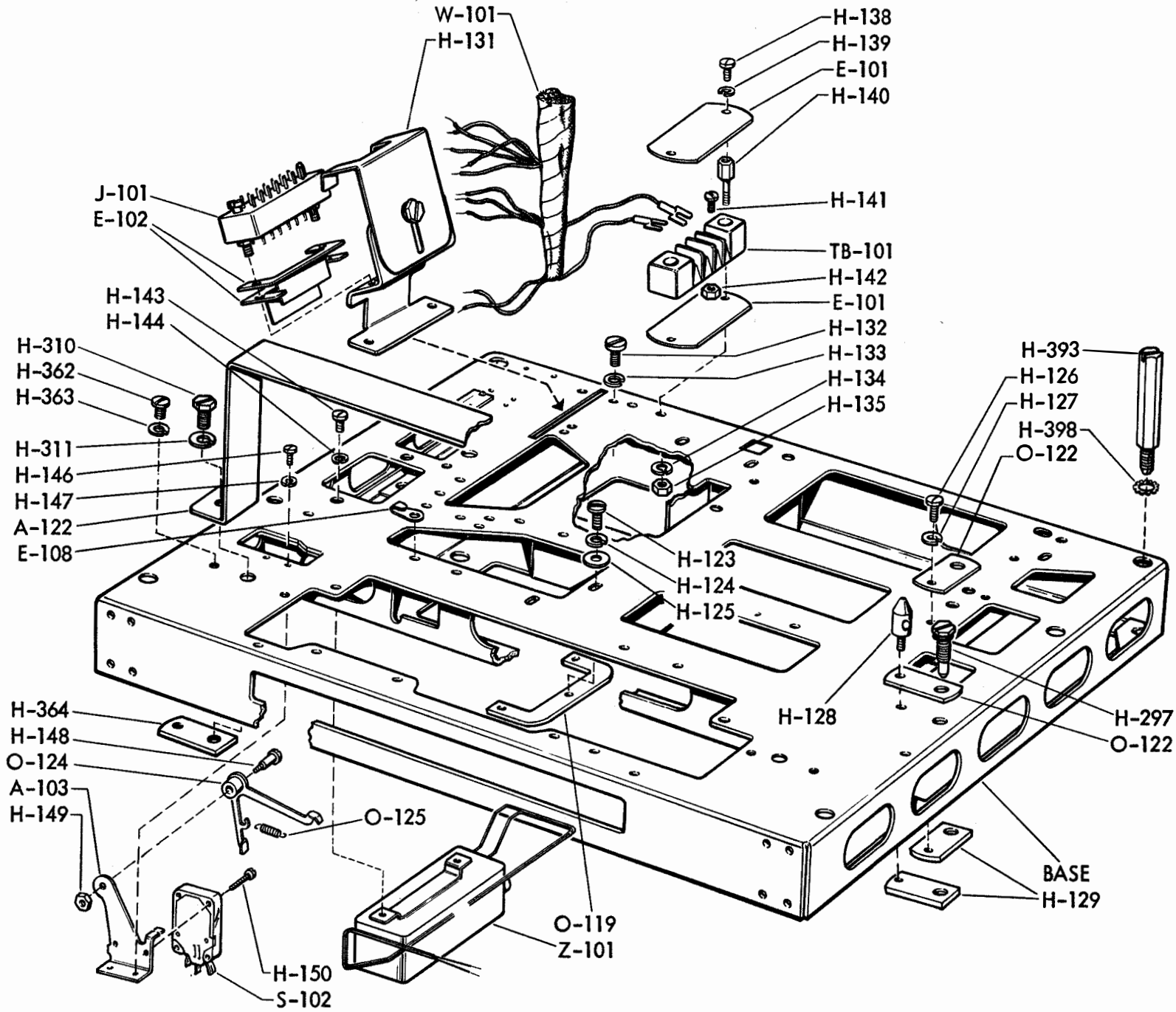


Figure 7-95. Keyboard, Base Mechanism

CHANGE 1

7-103

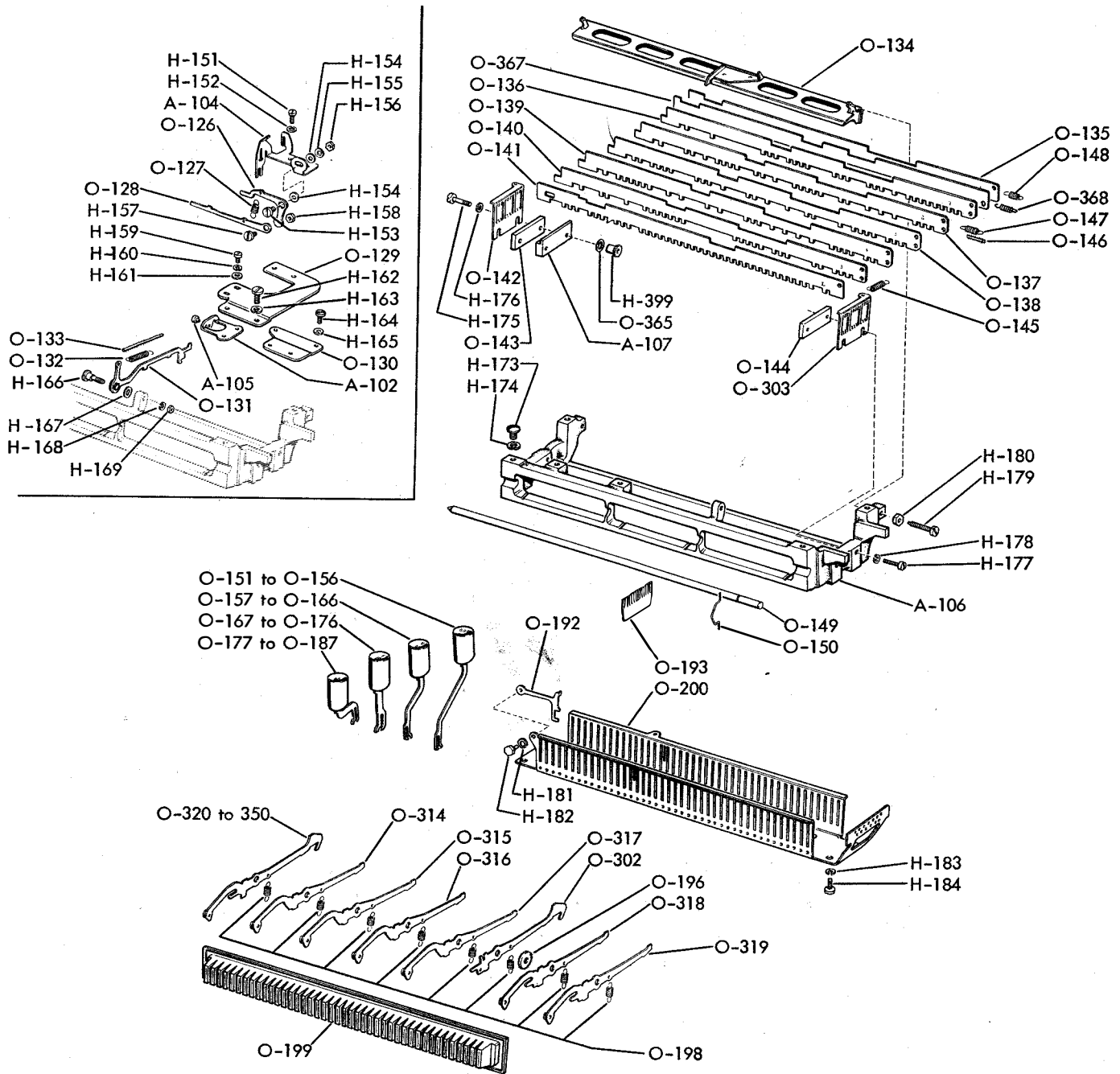
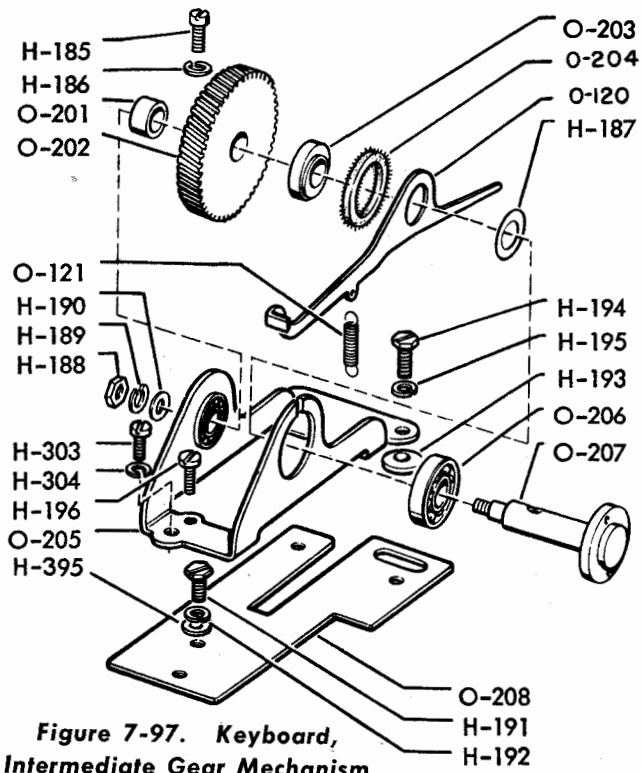
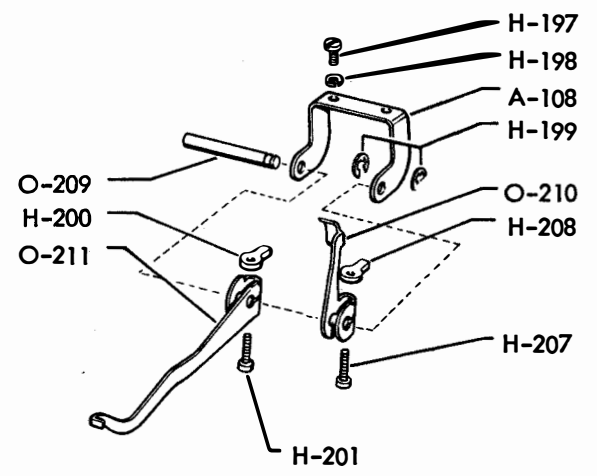


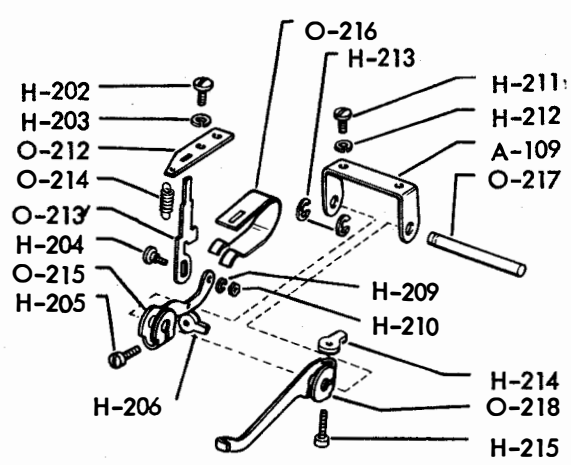
Figure 7-96. Keyboard, Code Bar Mechanism



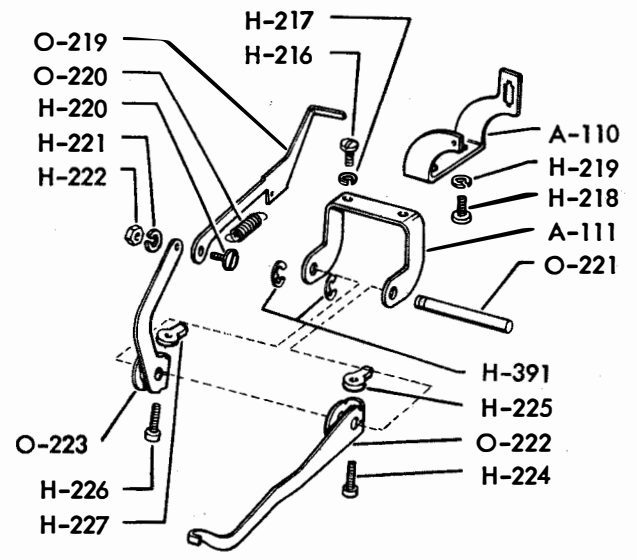
**Figure 7-97. Keyboard, Intermediate Gear Mechanism**



**Figure 7-98. Keyboard, Carriage Return Mechanism**



**Figure 7-99. Keyboard Lock Mechanism**



**Figure 7-100. Keyboard, Local Line Feed Mechanism**

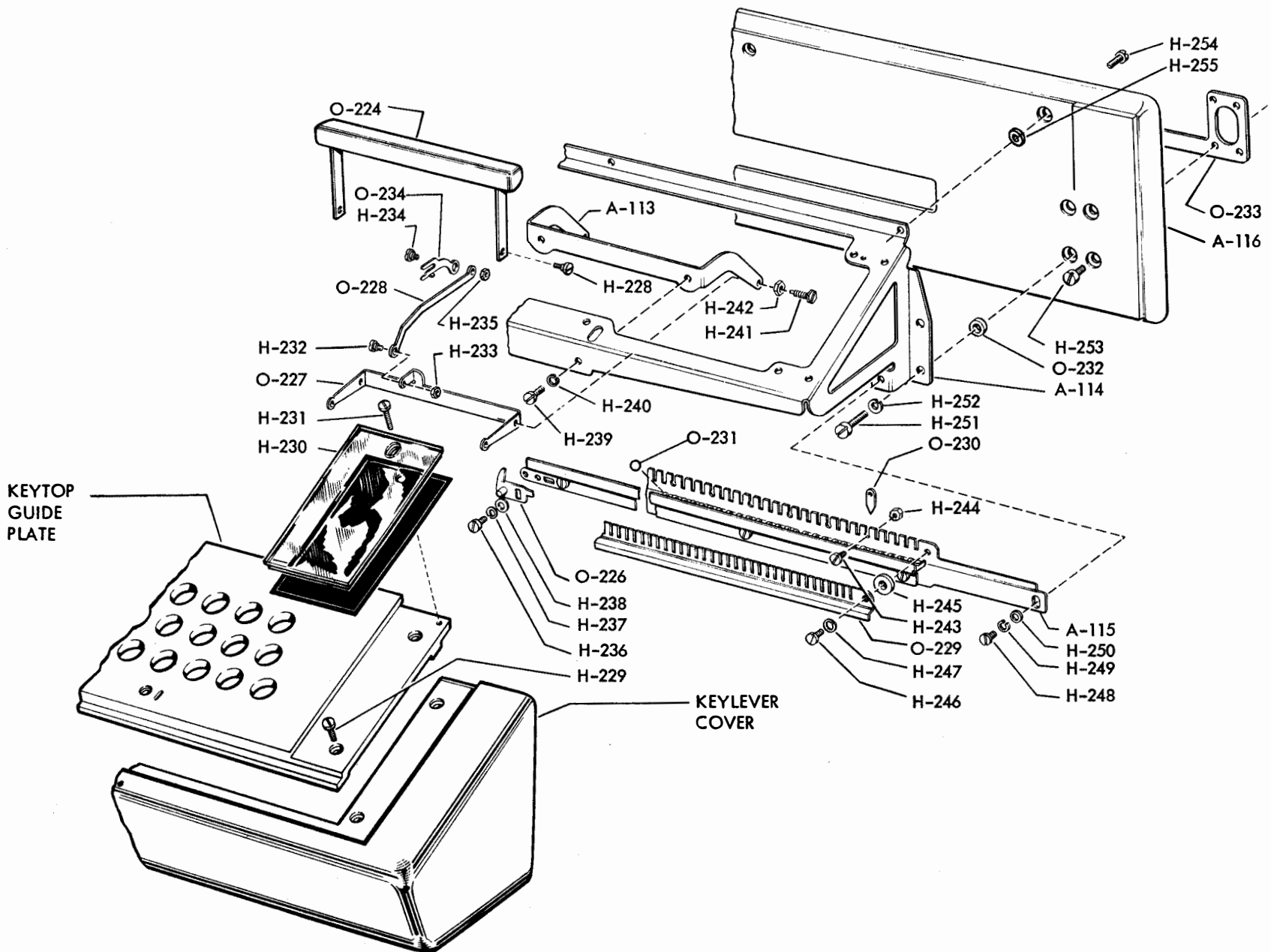


Figure 7-101. Keyboard Mechanism



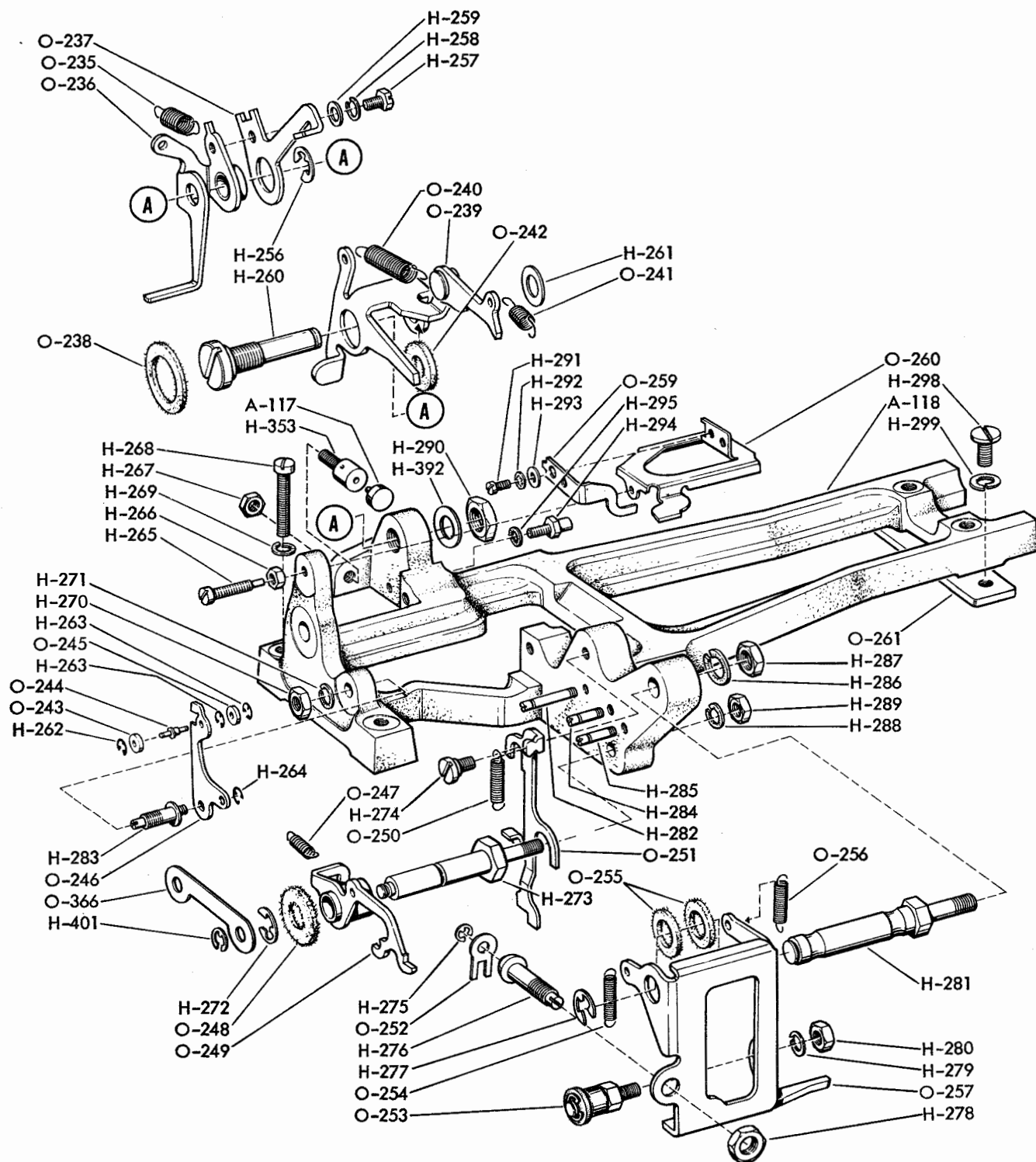


Figure 7-102. Keyboard, Signal Generator Mechanism

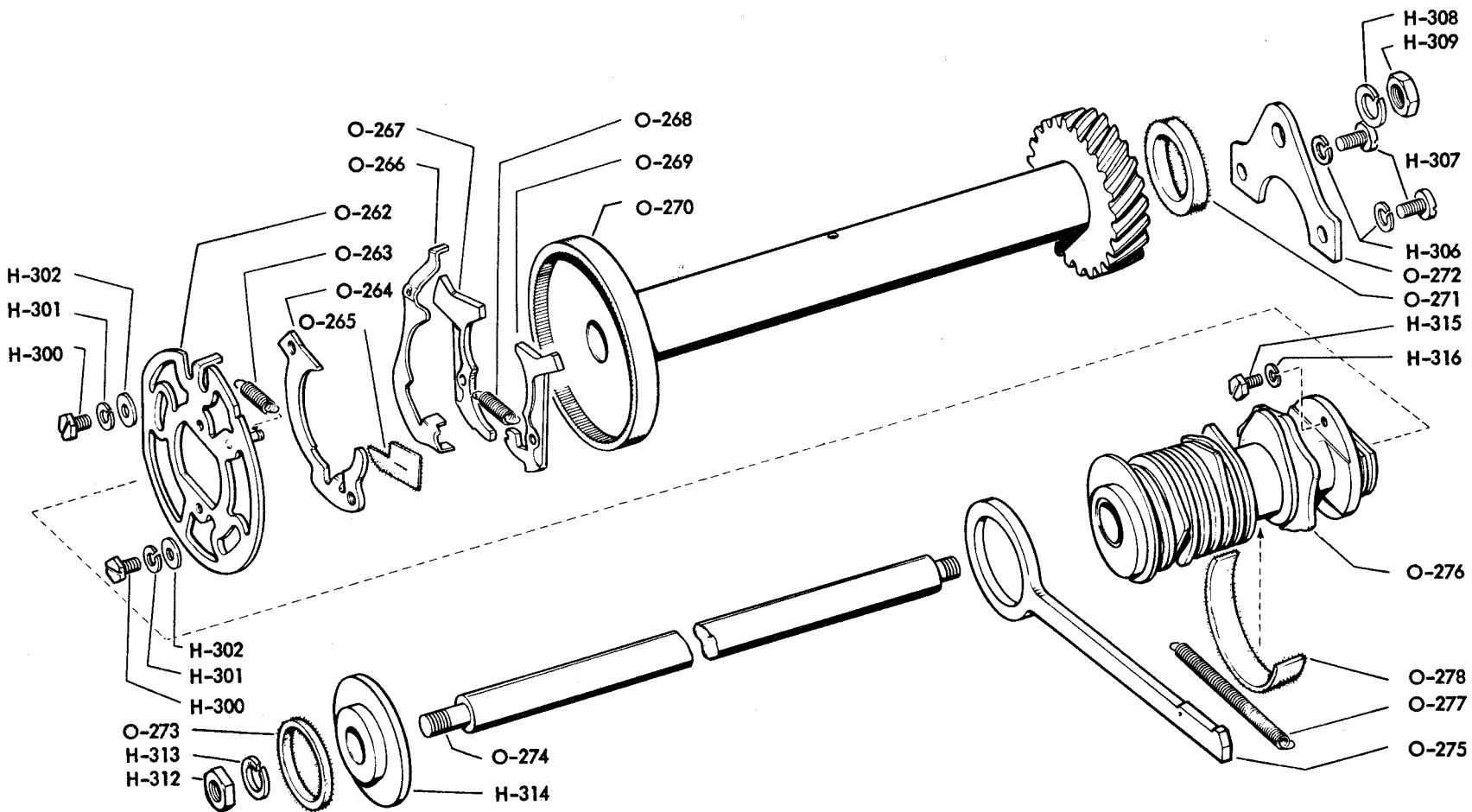


Figure 7-103. Keyboard, Signal Generator Mechanism

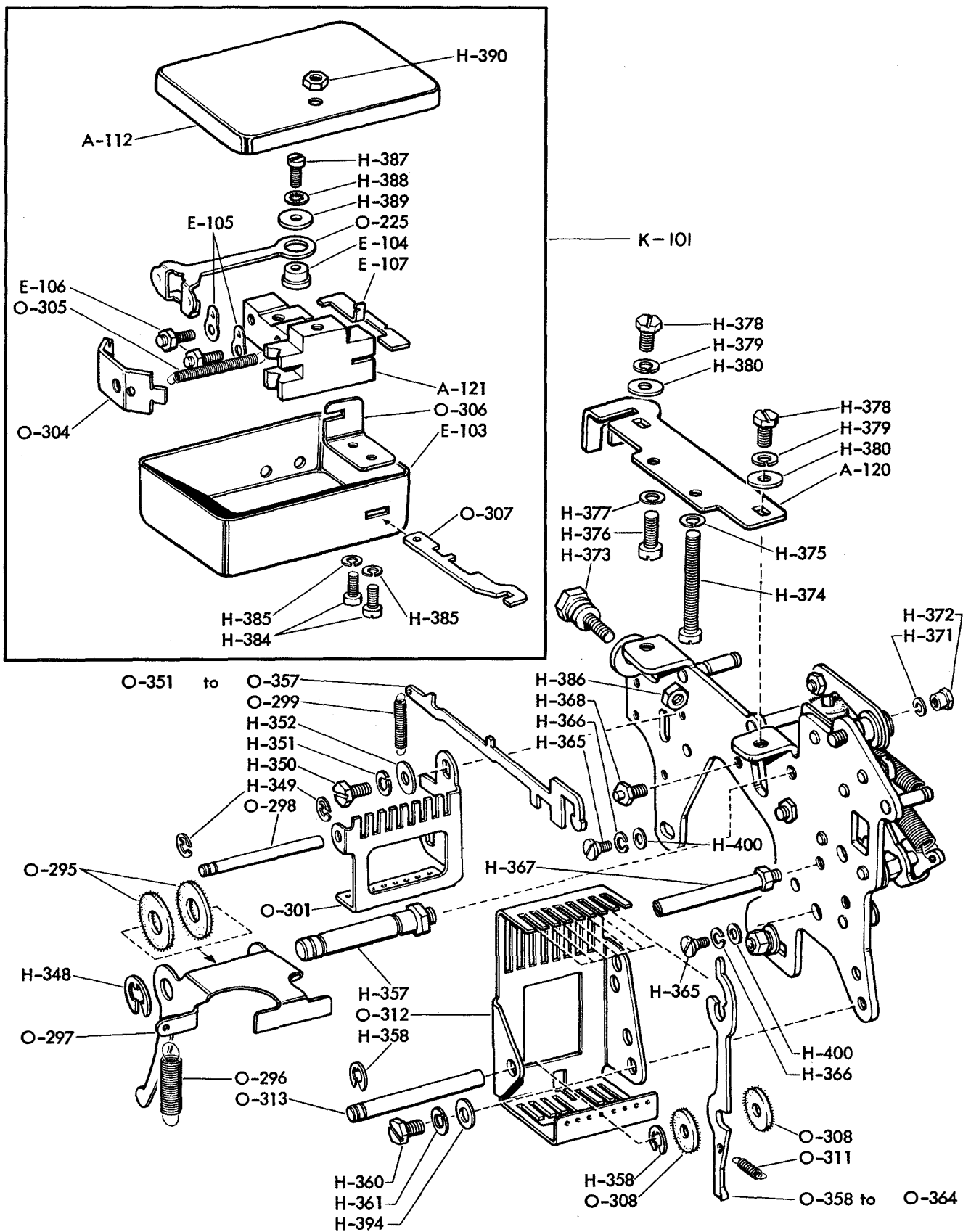


Figure 7-104. Keyboard, Signal Generator Mechanism

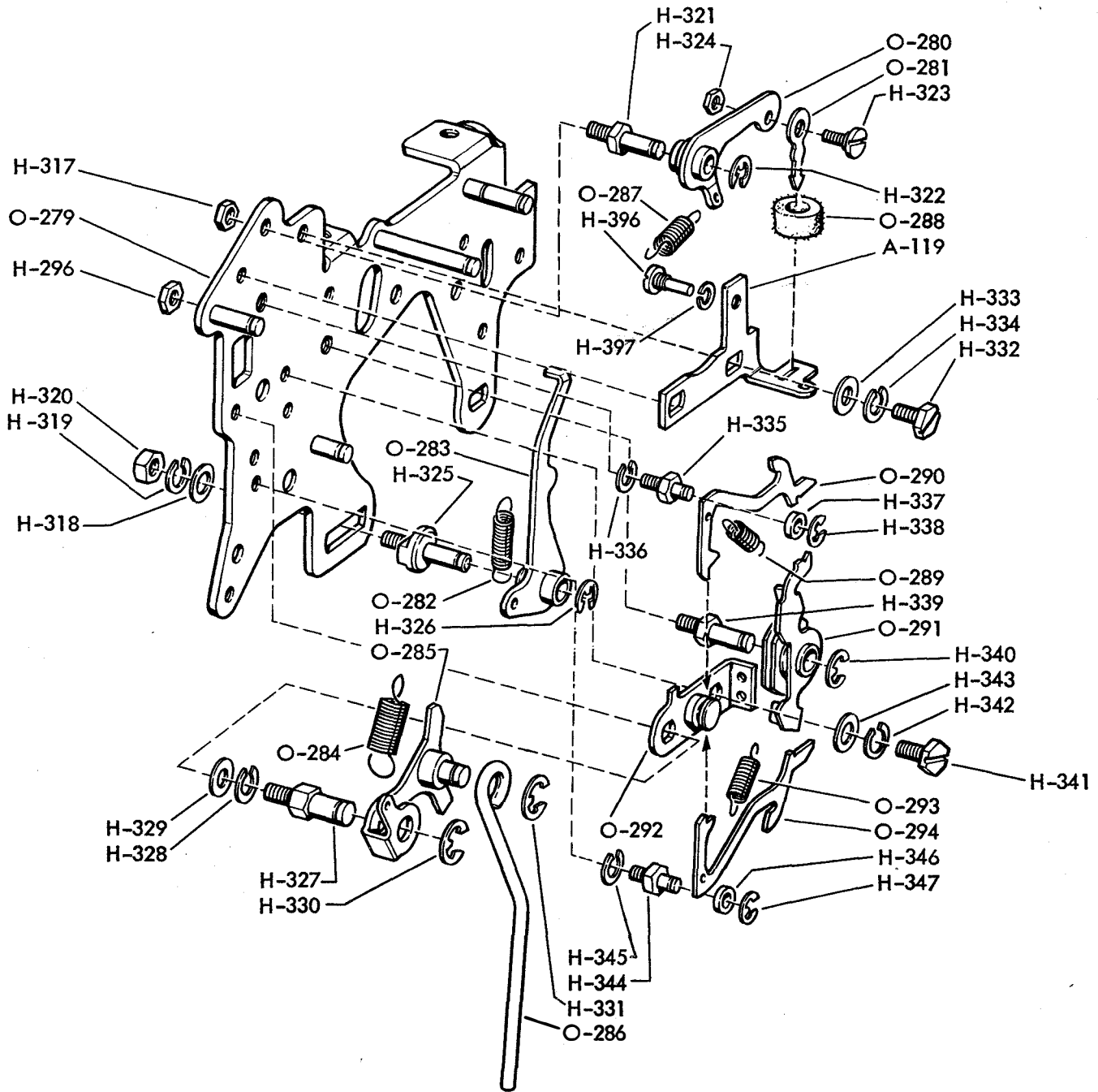


Figure 7-105. Keyboard, Signal Generator Mechanism

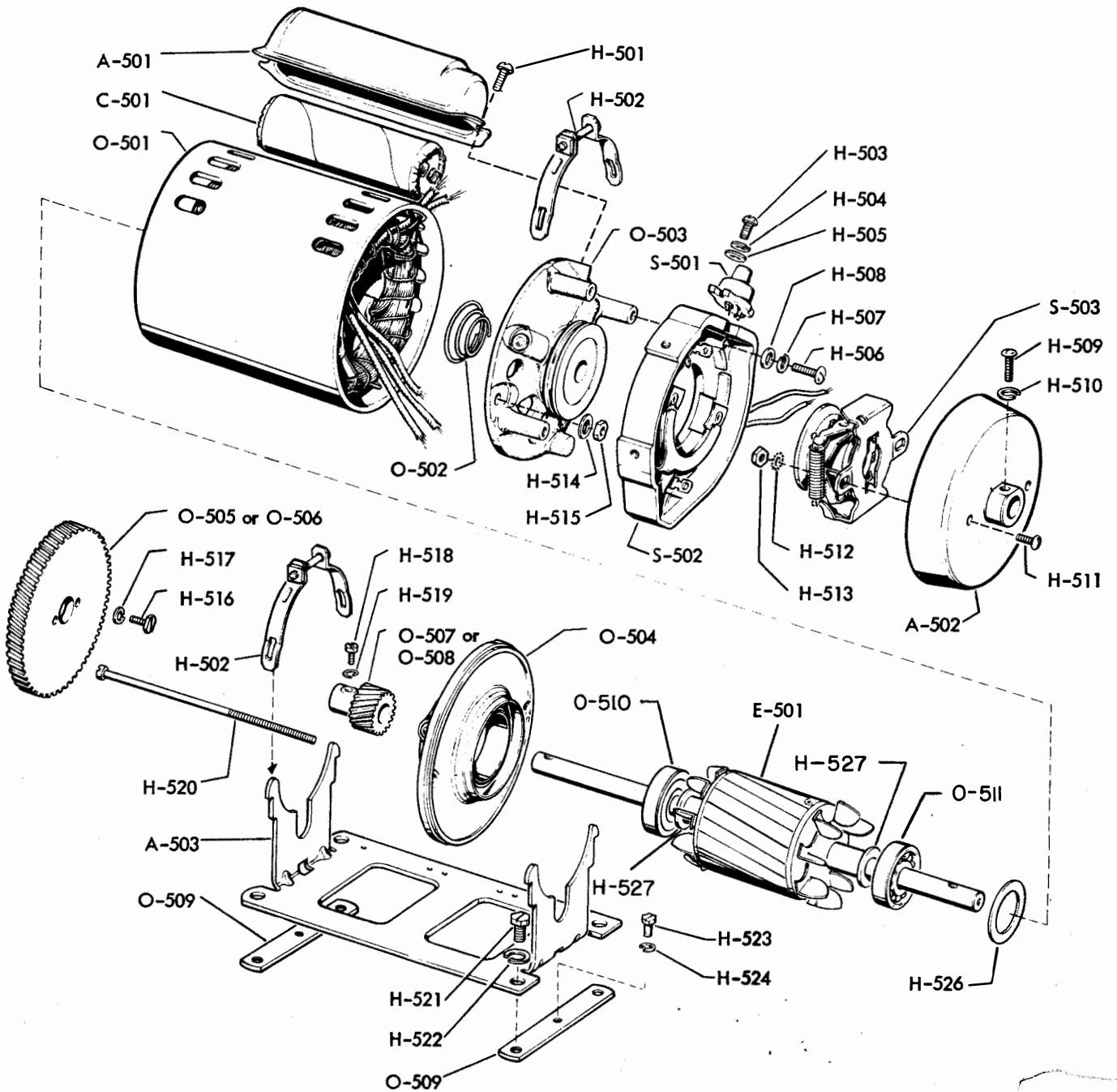


Figure 7-106. Synchronous Motor PD-17/U

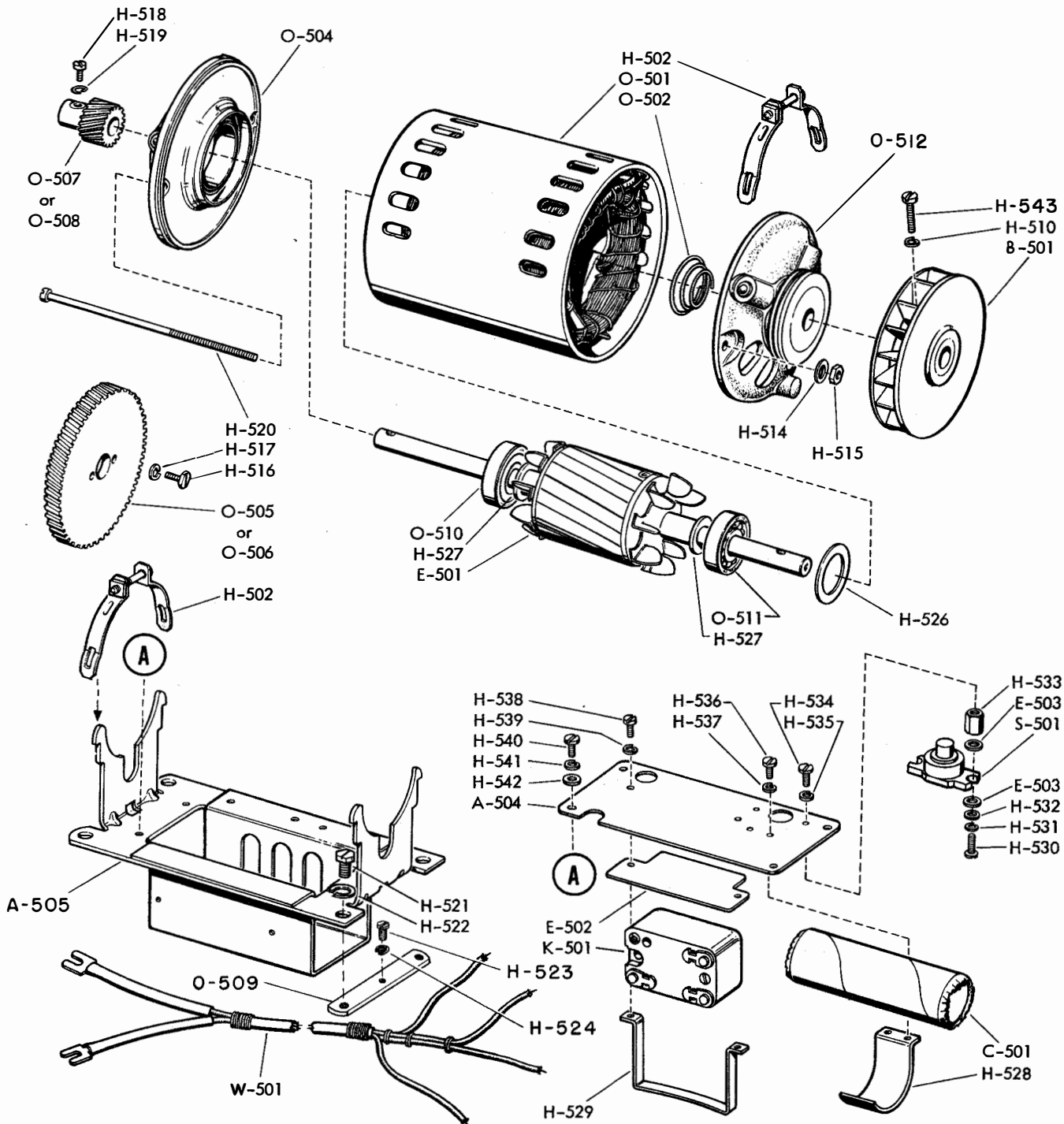


Figure 7-107. Synchronous Motor, PD-17A/U

Figure 7-107. Governed Motor

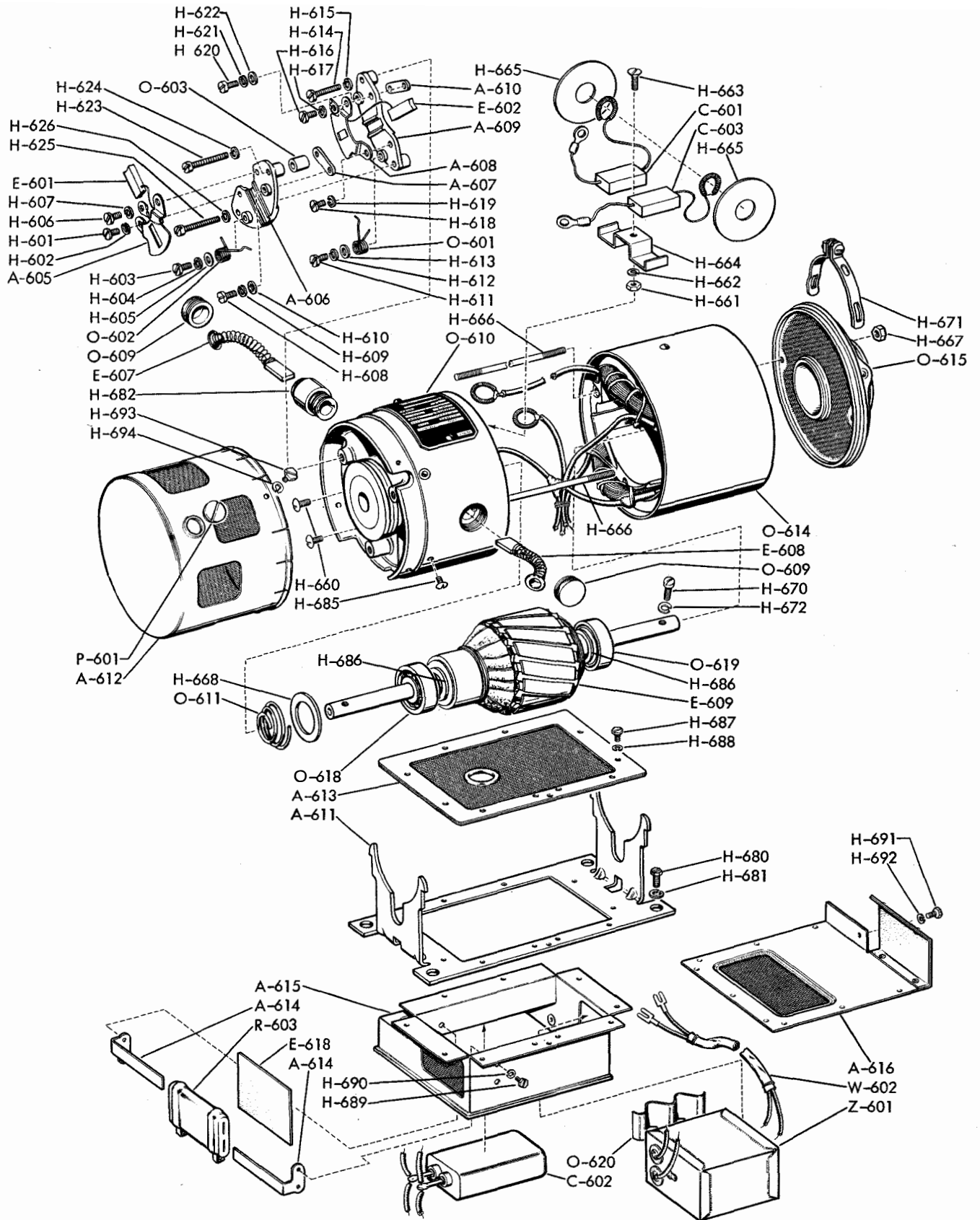
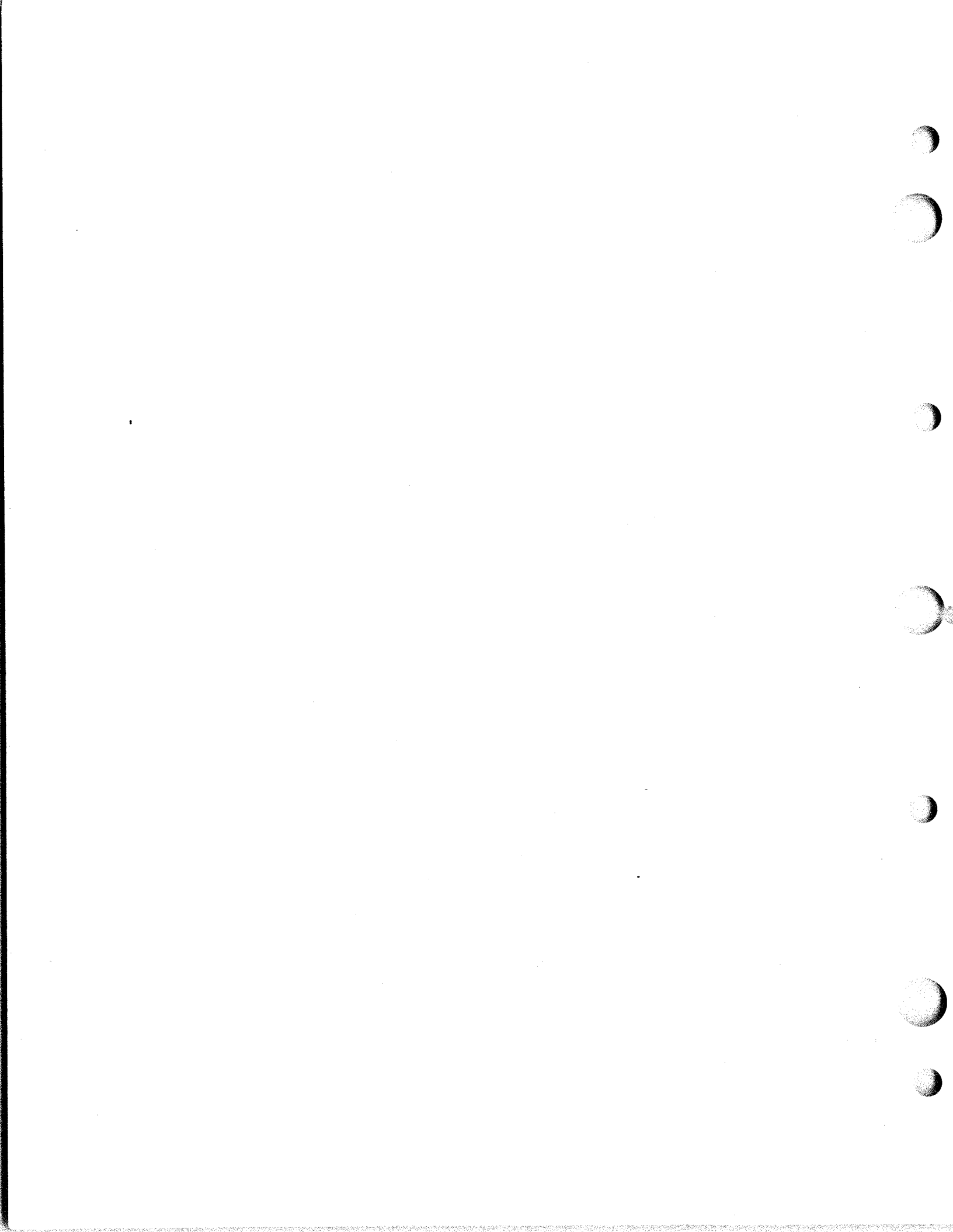


Figure 7-107A. Governed Motor, PD-18/U





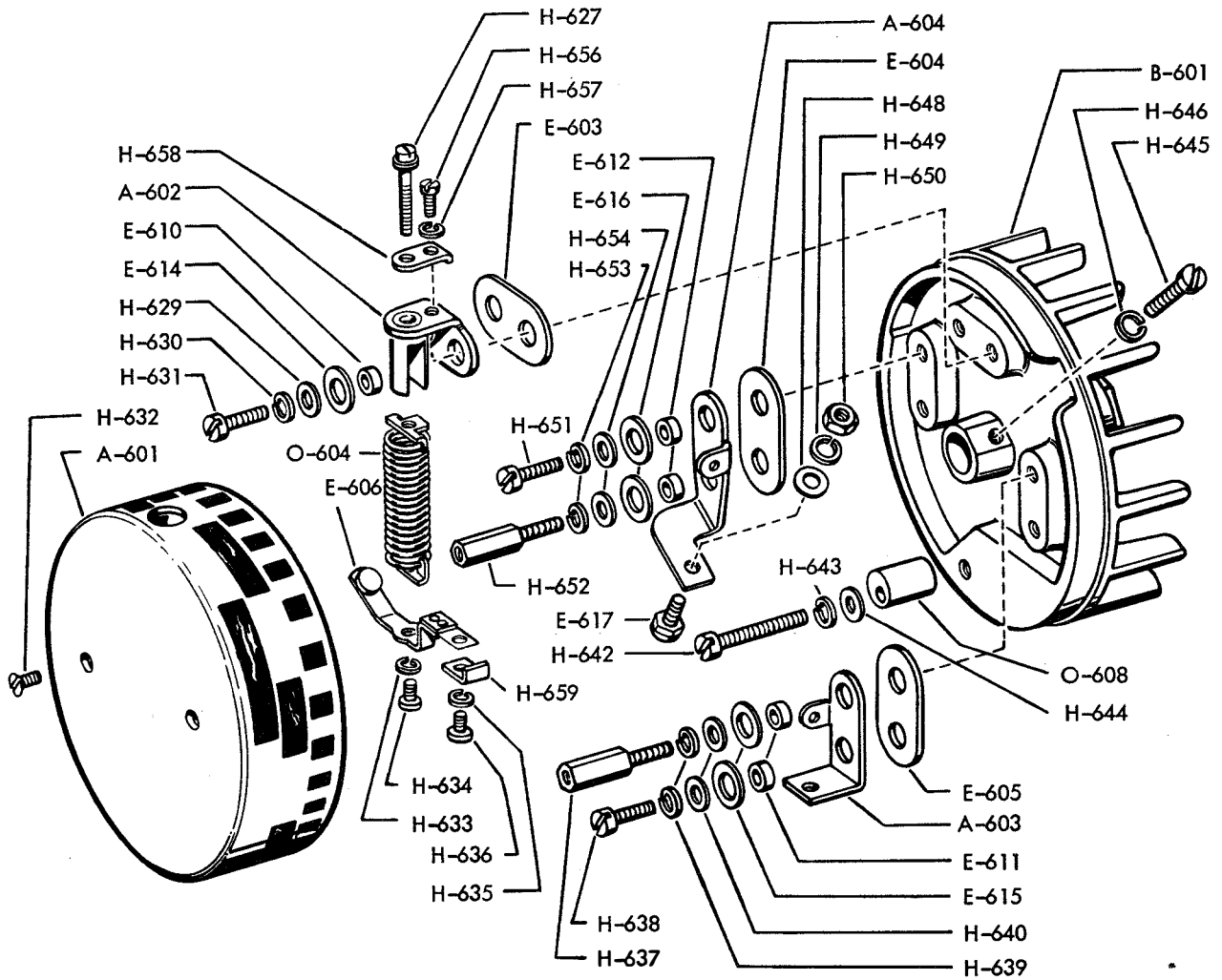


Figure 7-108. Governor Mechanism

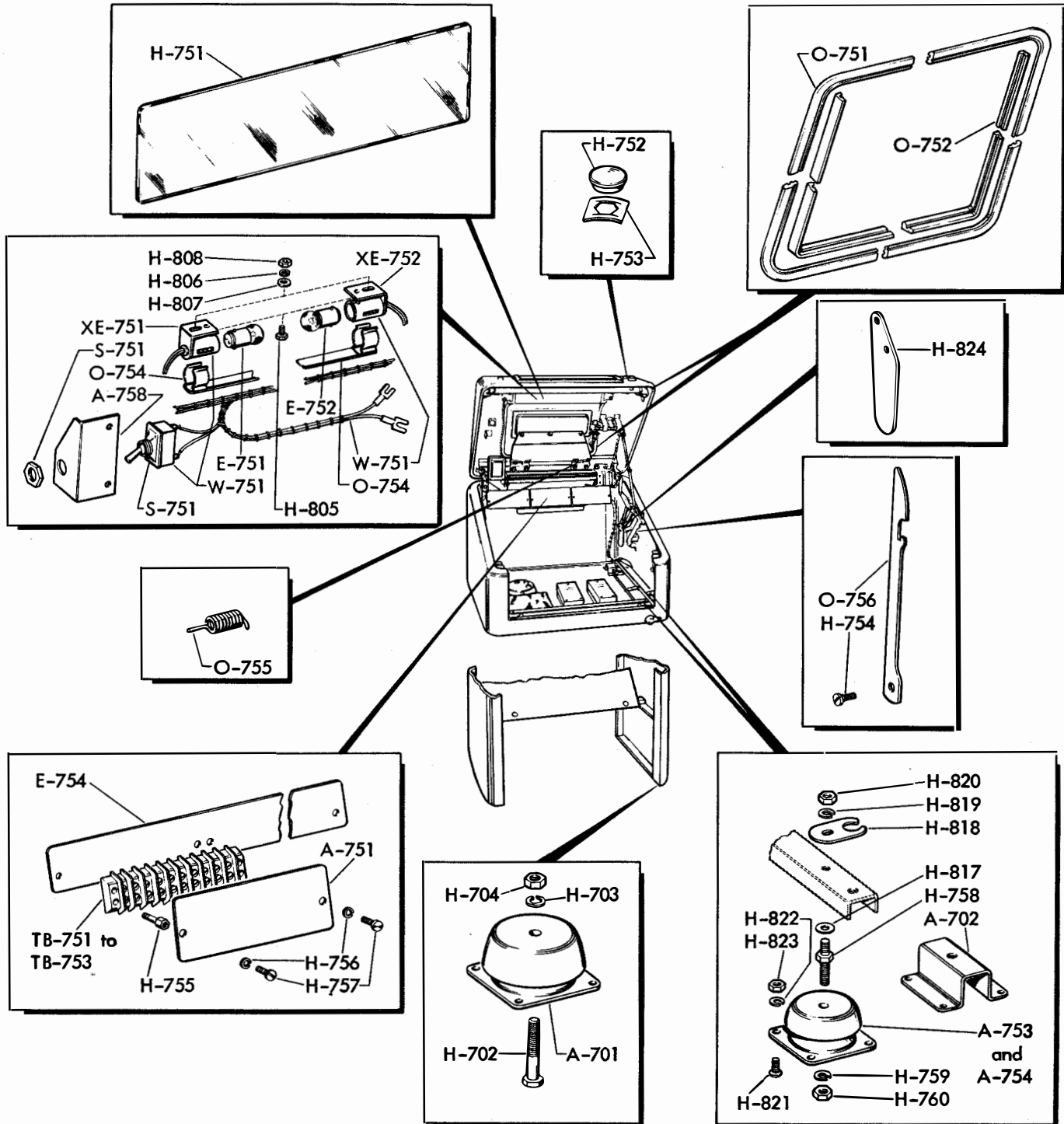


Figure 7-109. Cabinet

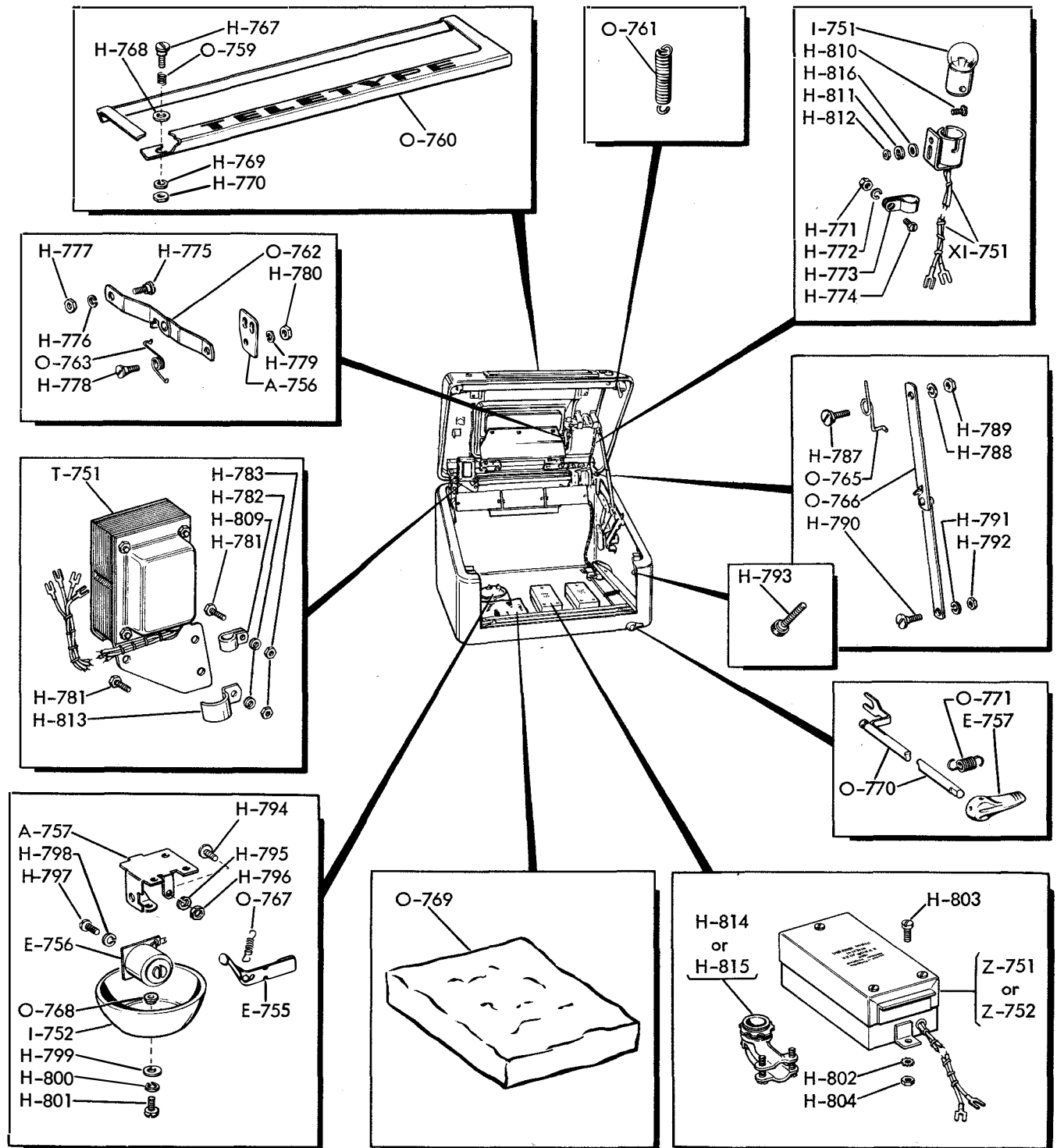


Figure 7-110. Cabinet

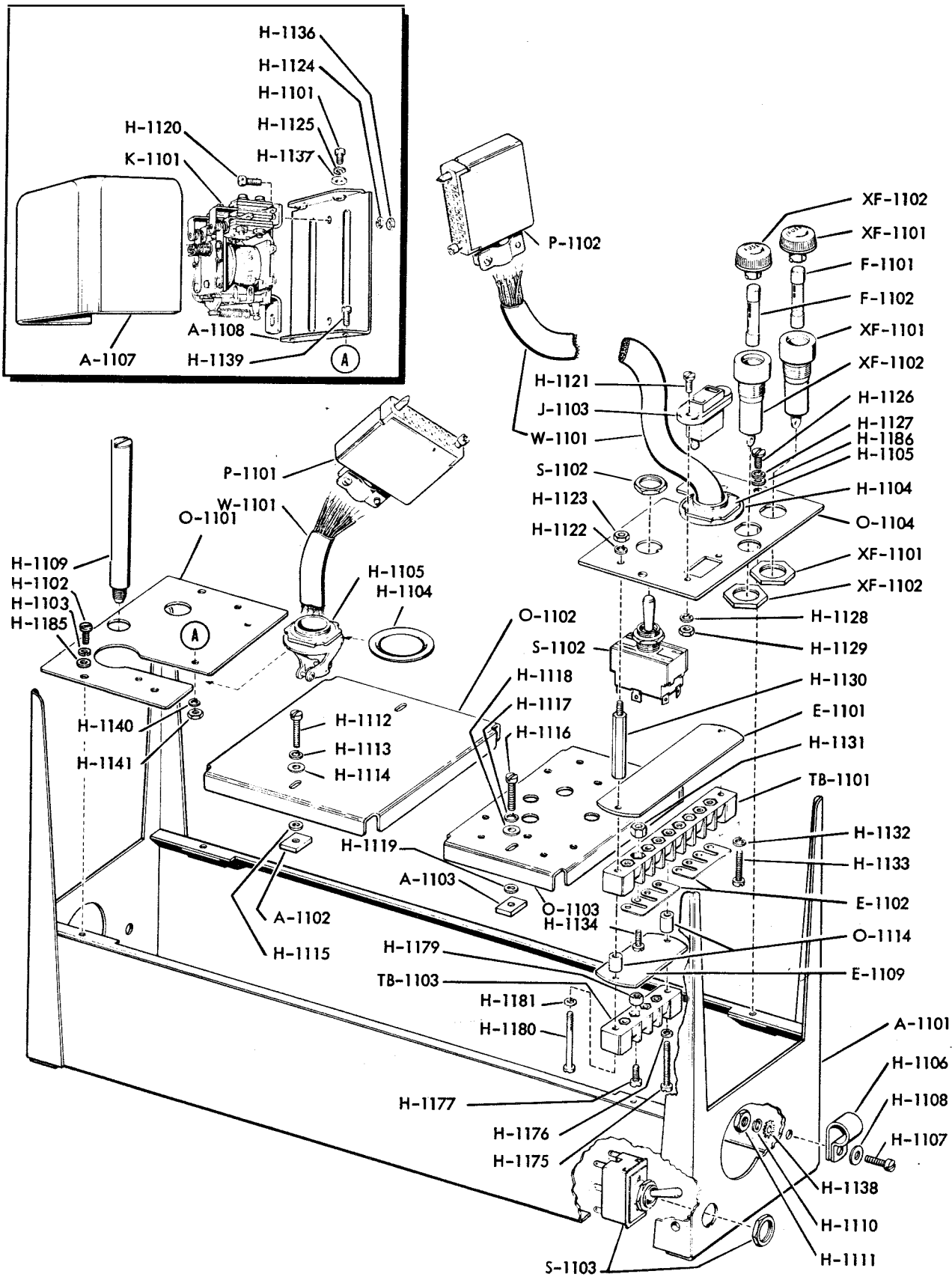


Figure 7-111. Power Distribution Panel

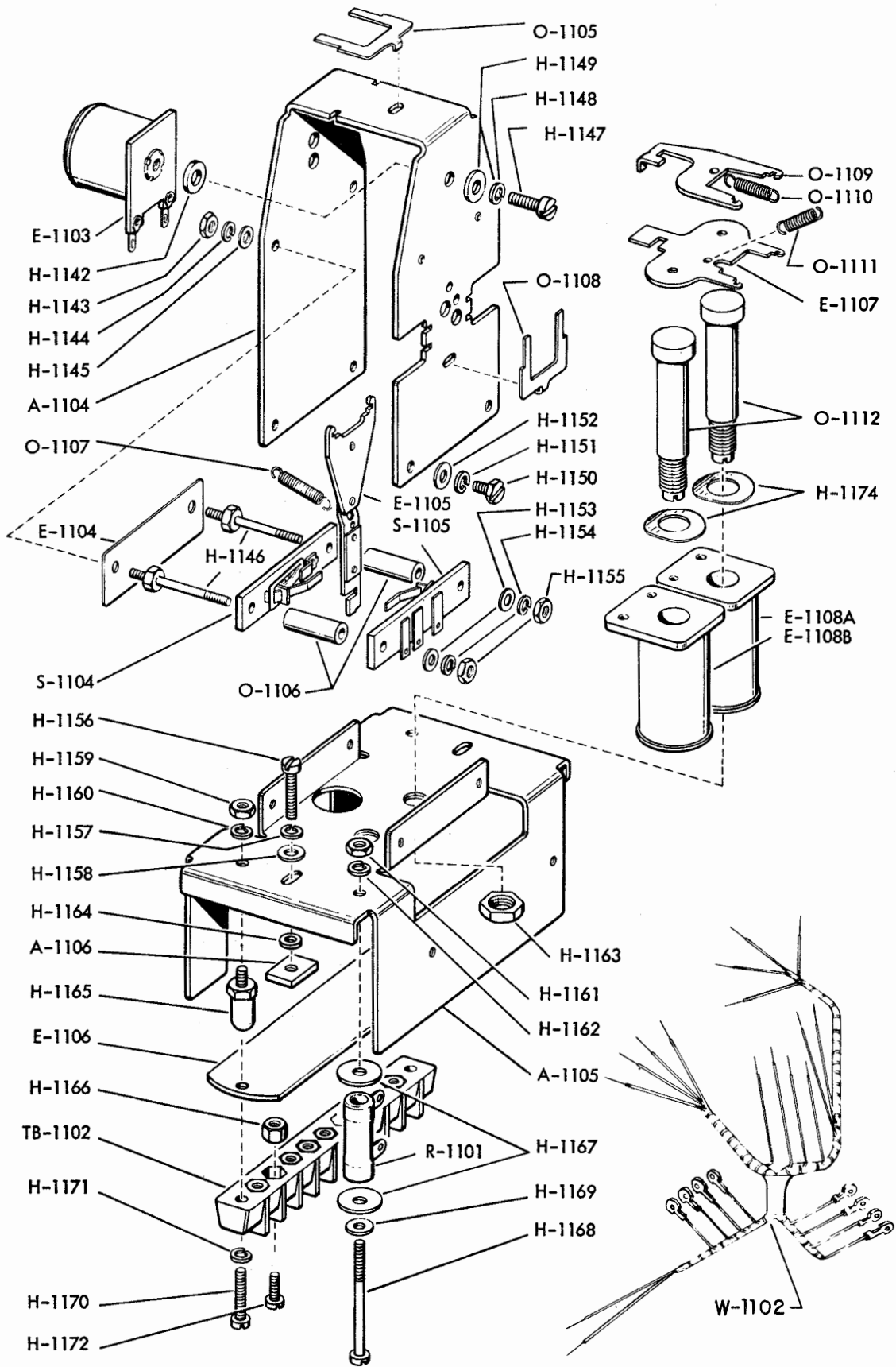


Figure 7-112. Power Distribution Panel, Motor Control Mechanism



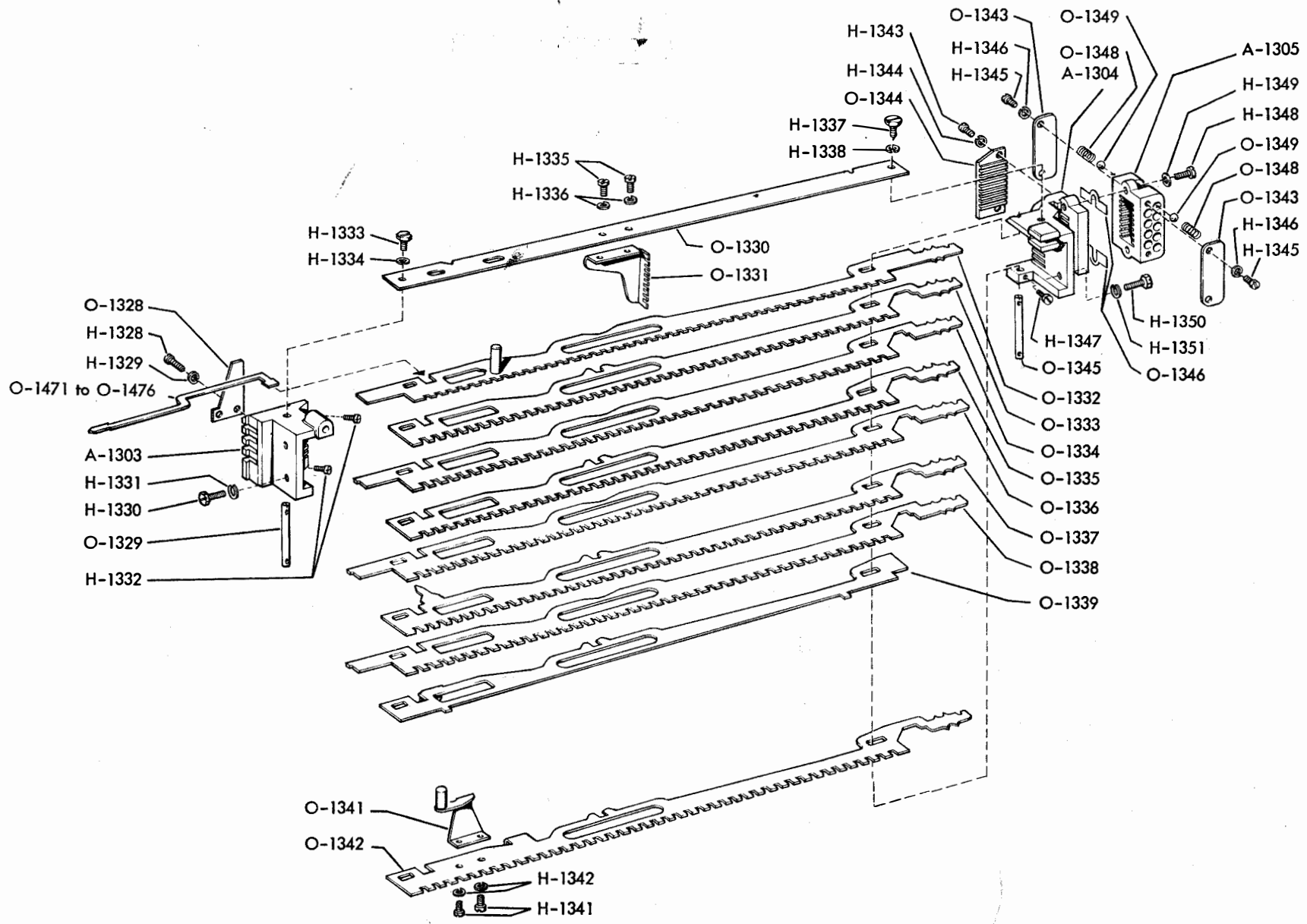


Figure 7-114. Automatic Typewriter, Code Bar Mechanism

ORIGINAL

7-119

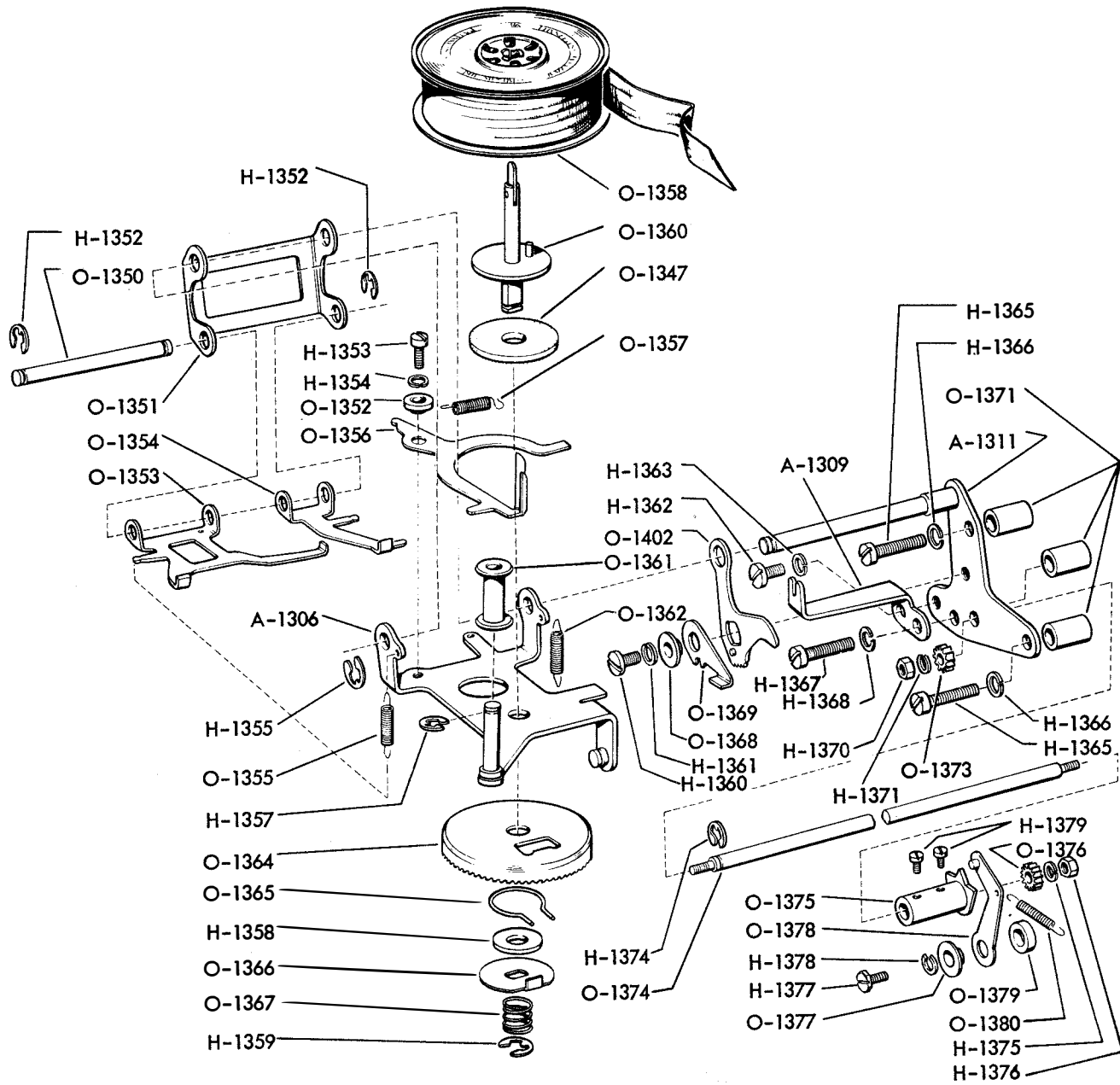


Figure 7-115. Automatic Typewriter, Left Ribbon Feed Mechanism



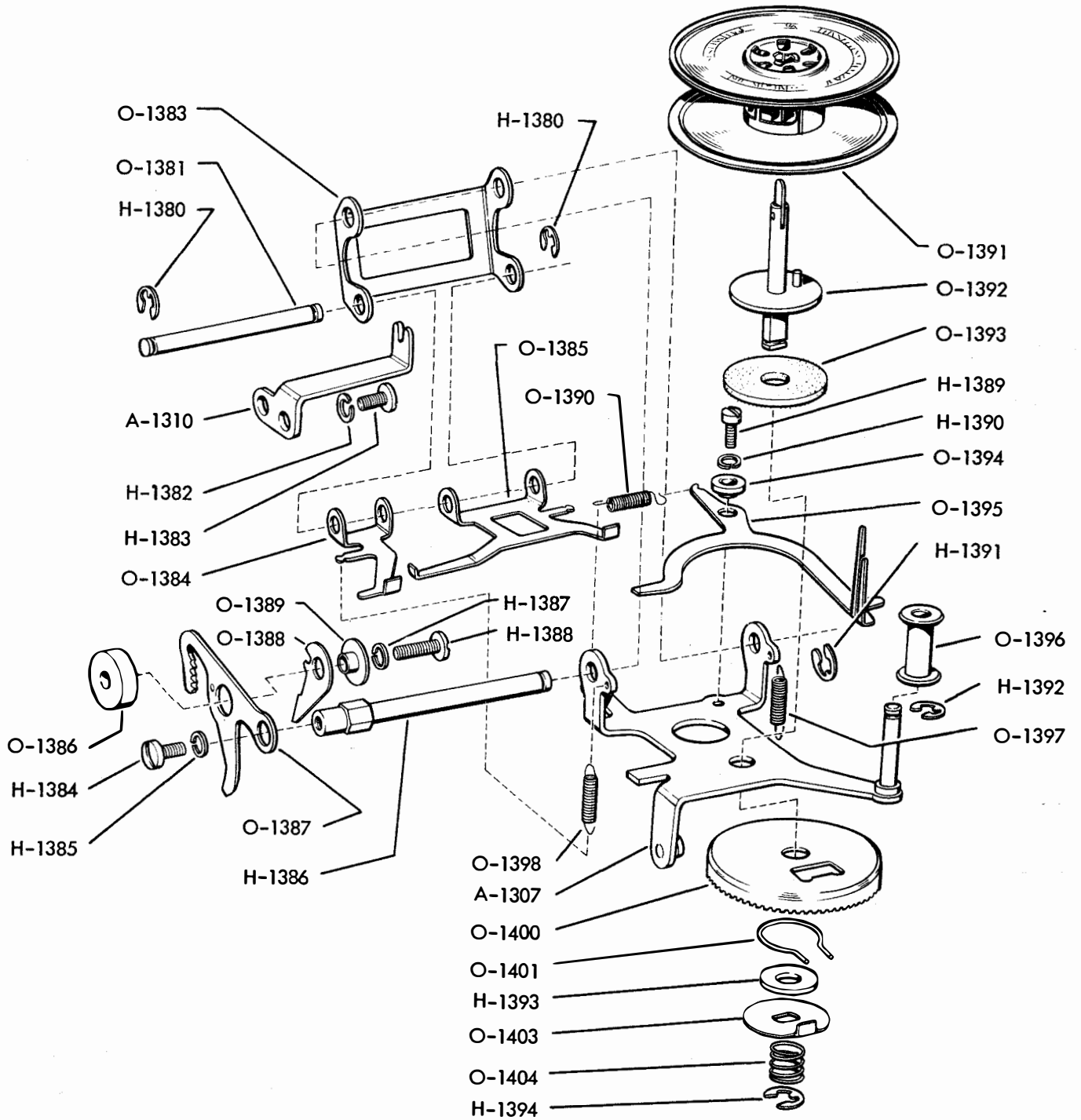


Figure 7-116. Automatic Typewriter, Right Ribbon Feed Mechanism

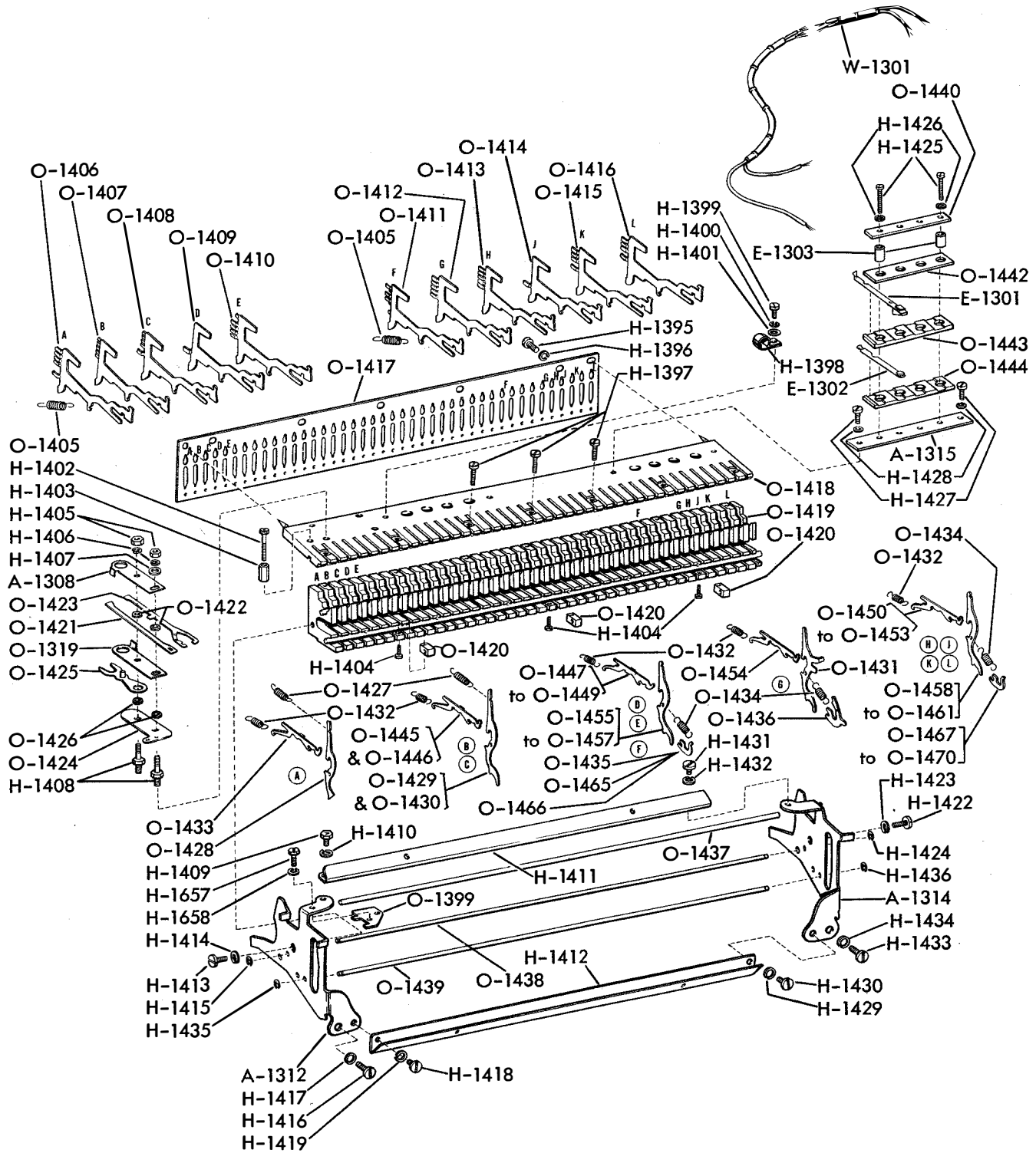


Figure 7-117. Automatic Typewriter, Function Box

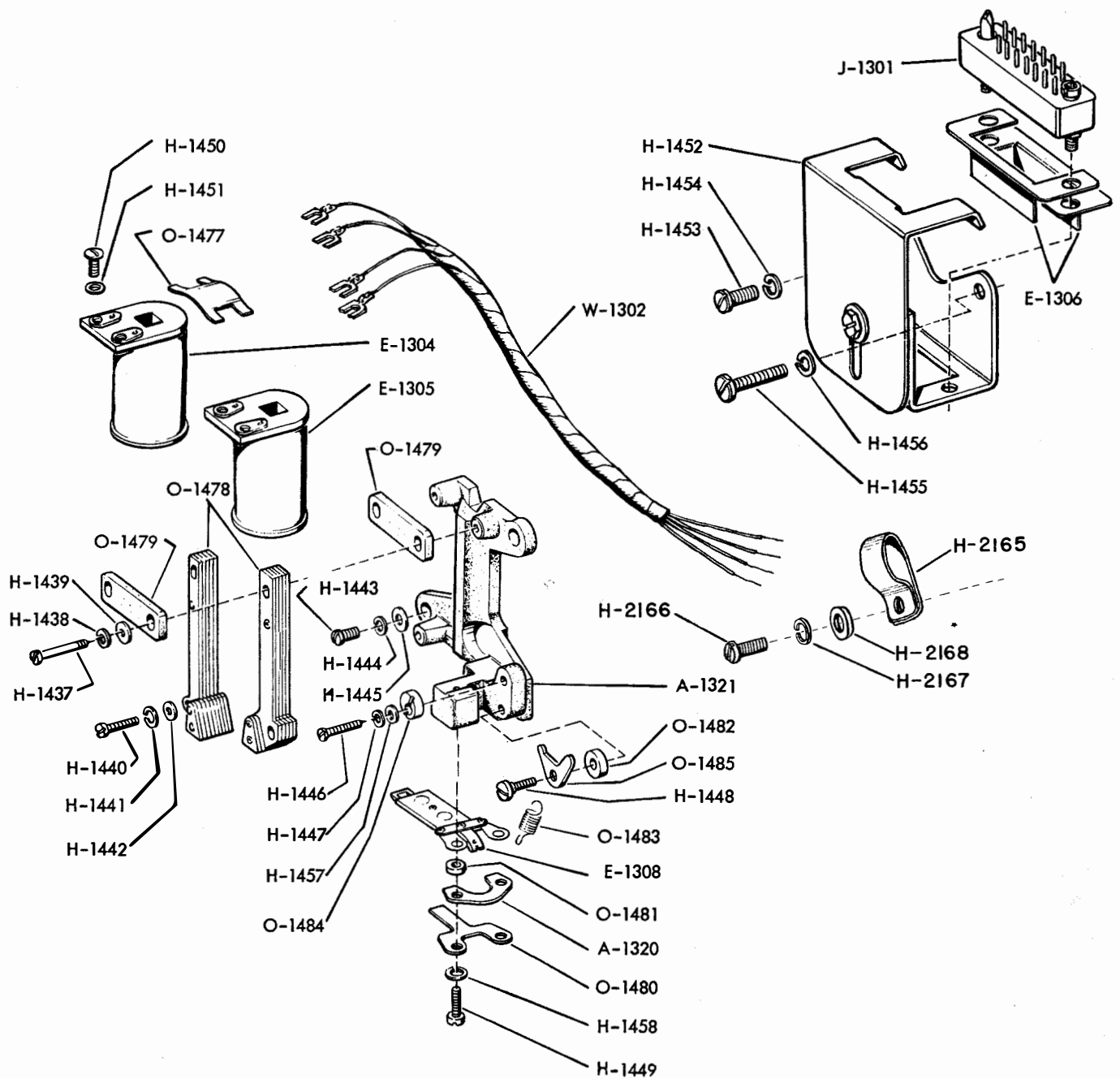


Figure 7-118. Automatic Typer, Selector Magnet Assembly

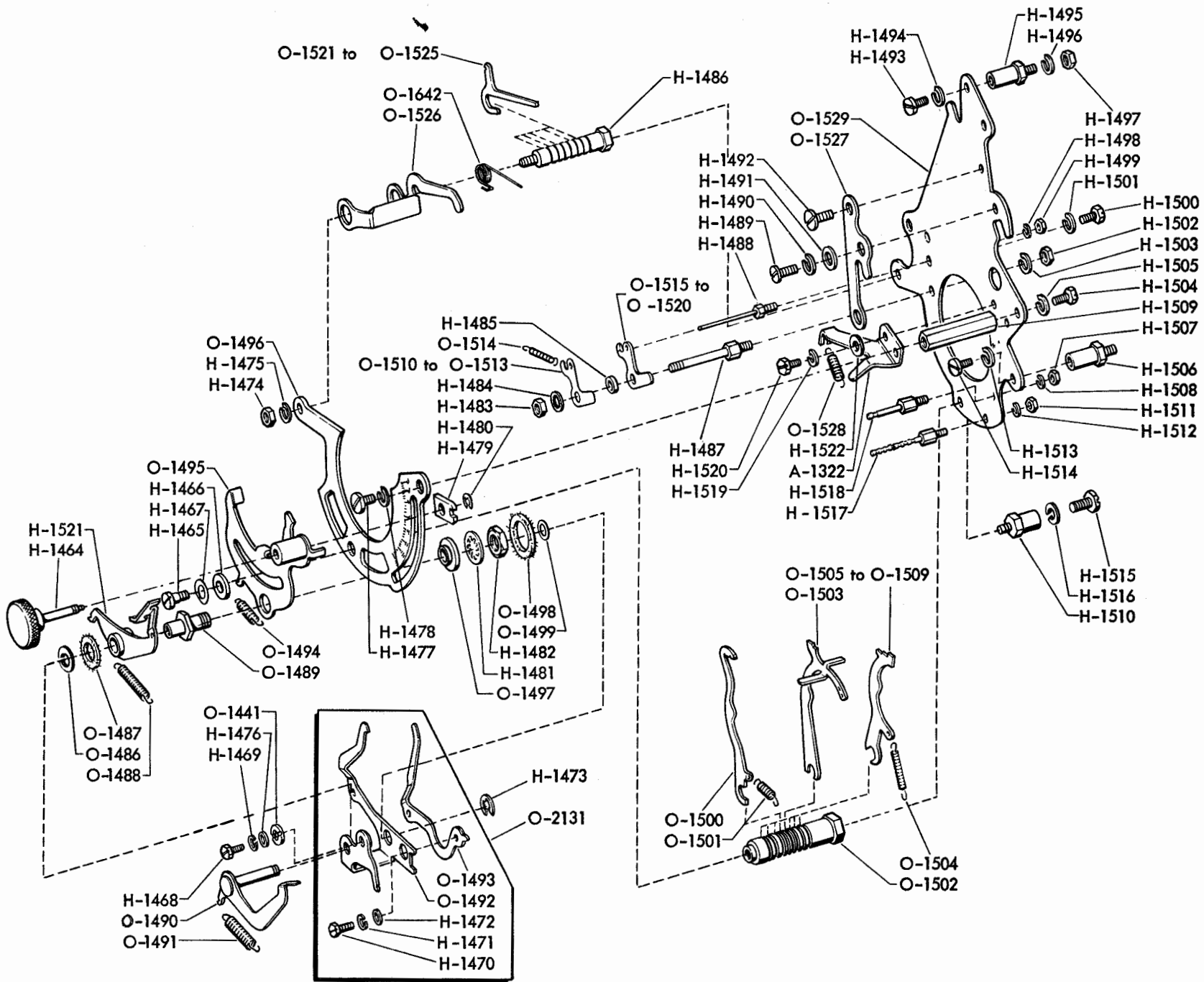
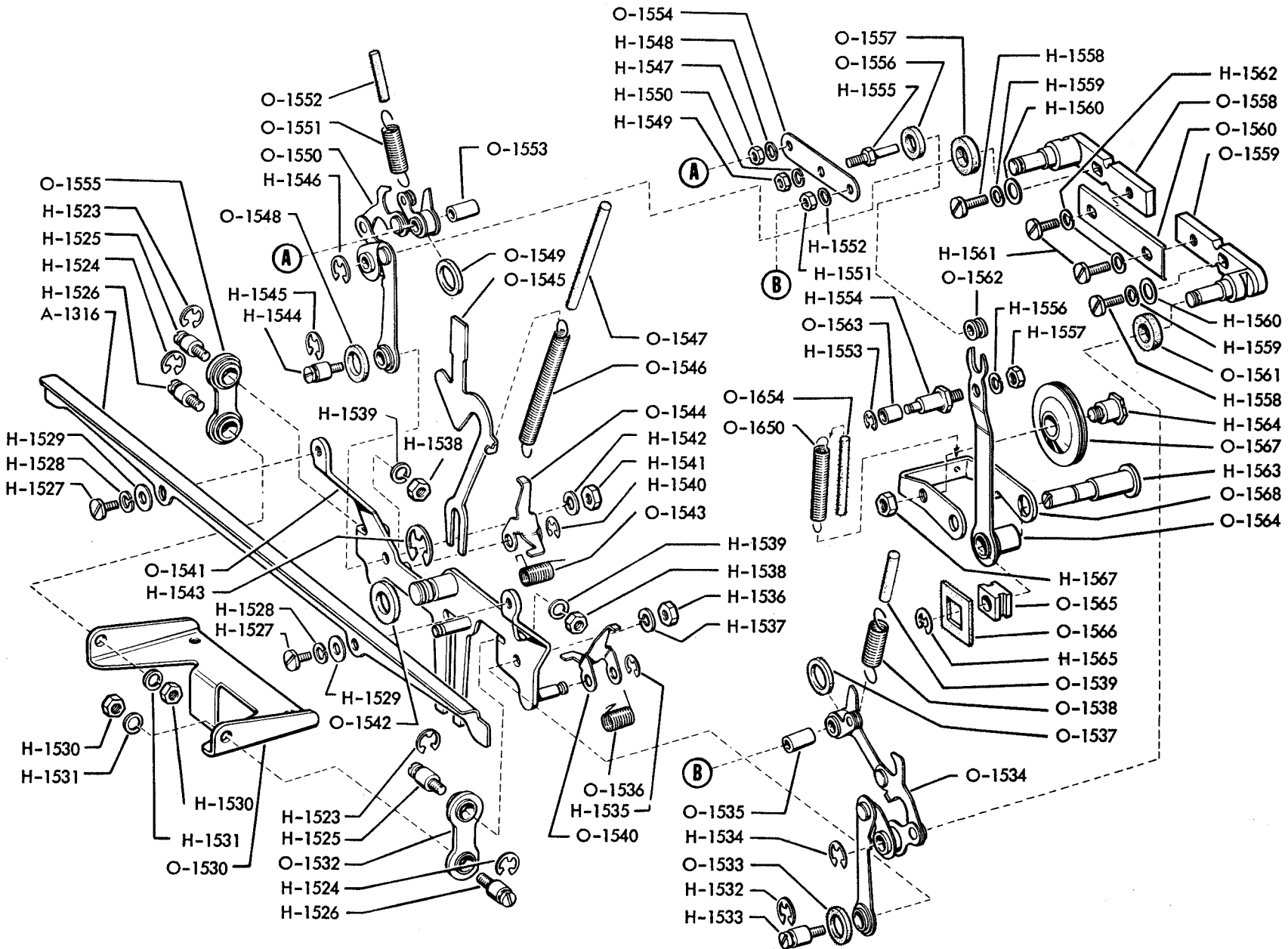


Figure 7-119. Automatic Typewriter, Selector Mechanism

Figure 7-120. Automatic Typewriter, Front Plate Mechanism





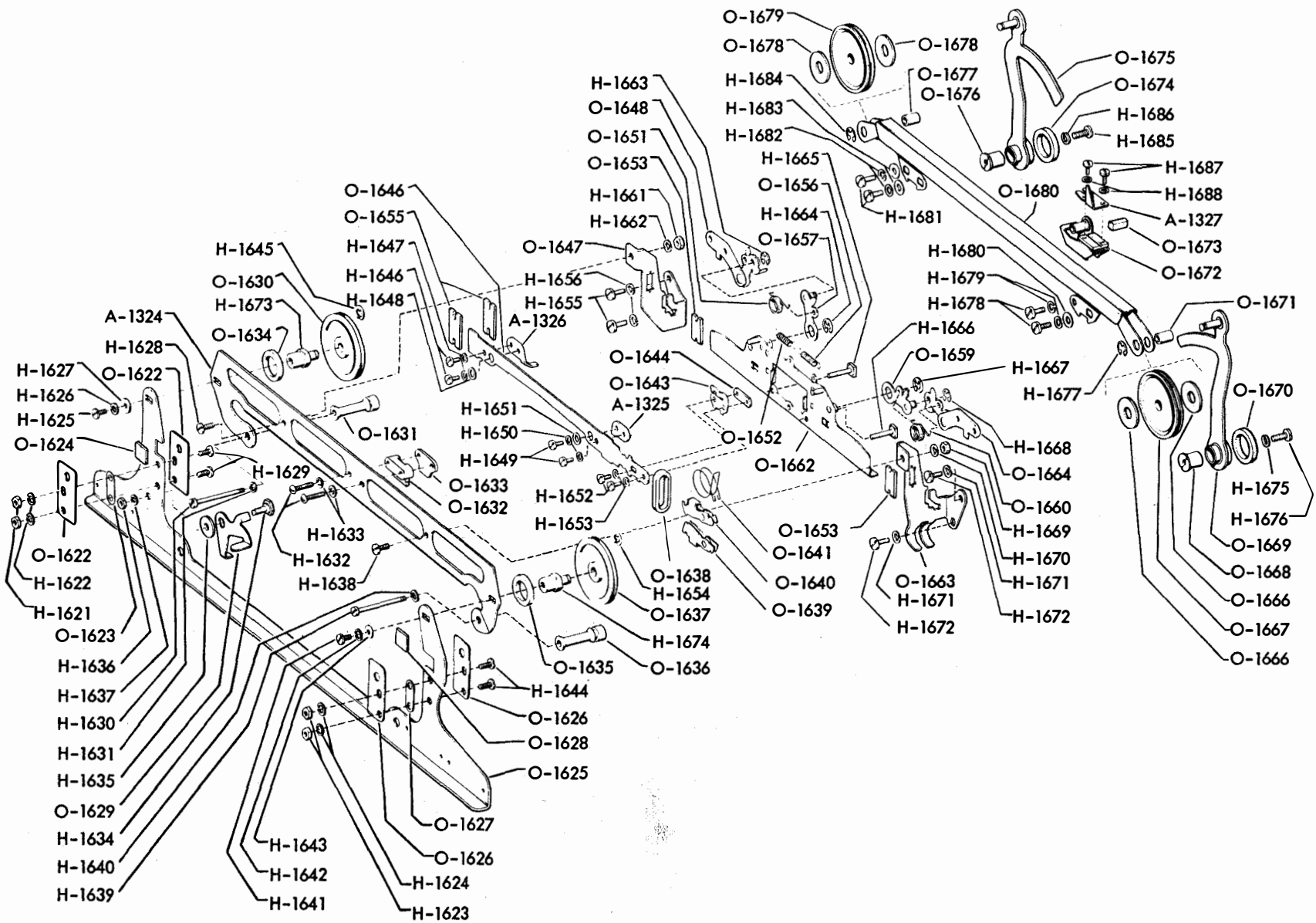


Figure 7-122. Automatic Typewriter, Front Plate Mechanism

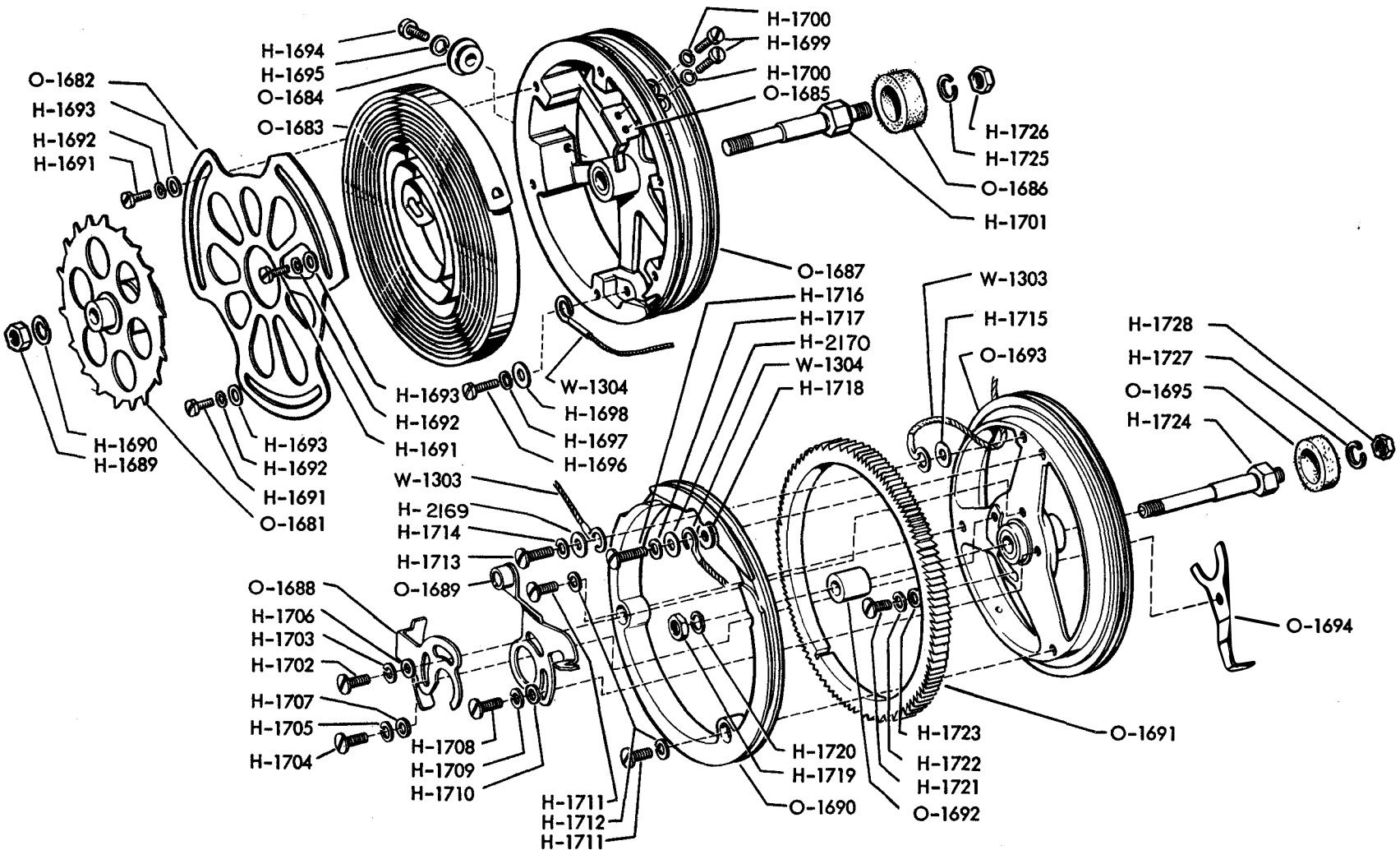


Figure 7-123. Automatic Typewriter, Spring Drum Mechanism



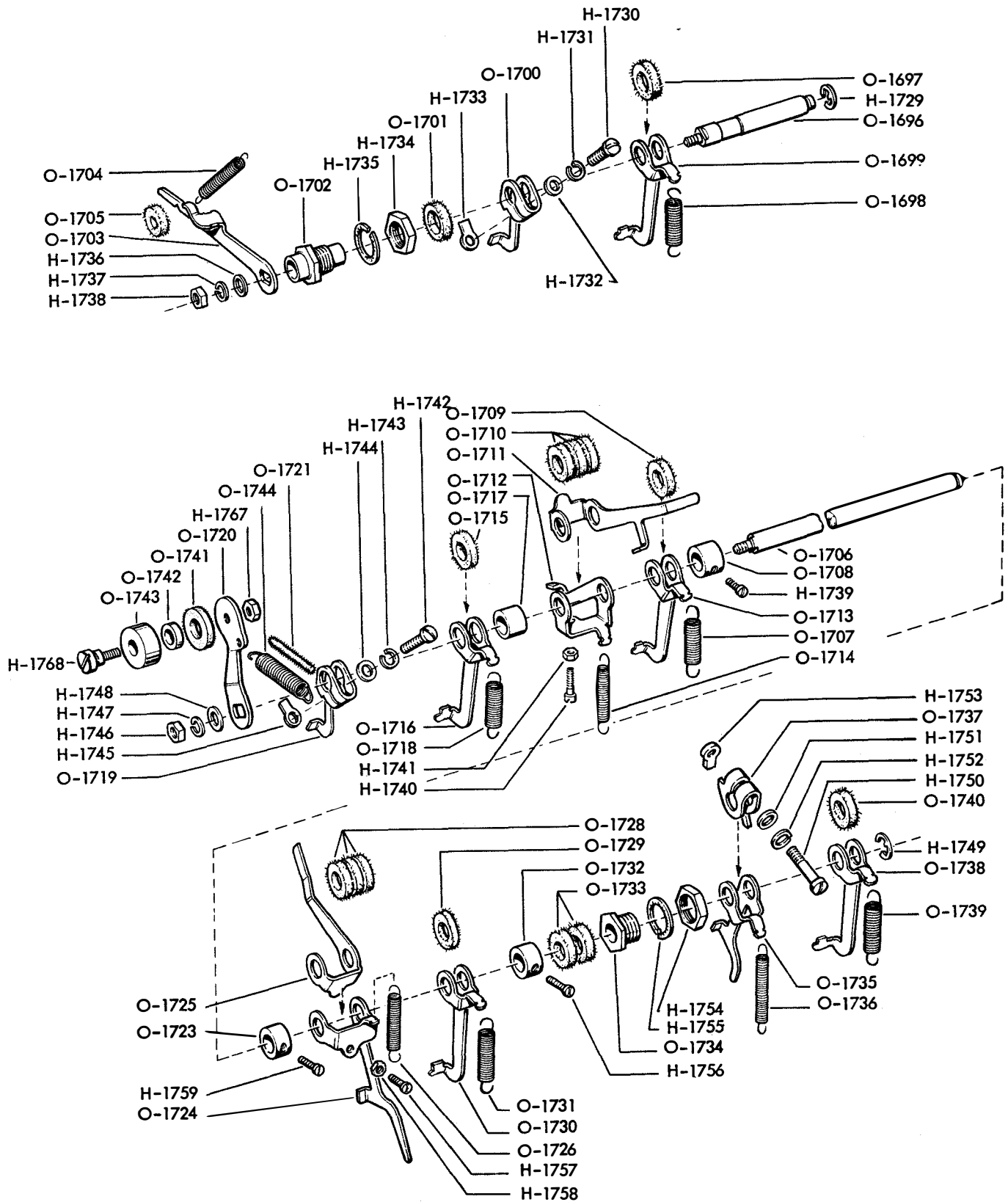


Figure 7-124. Automatic Typewriter, Trip Shaft Mechanism

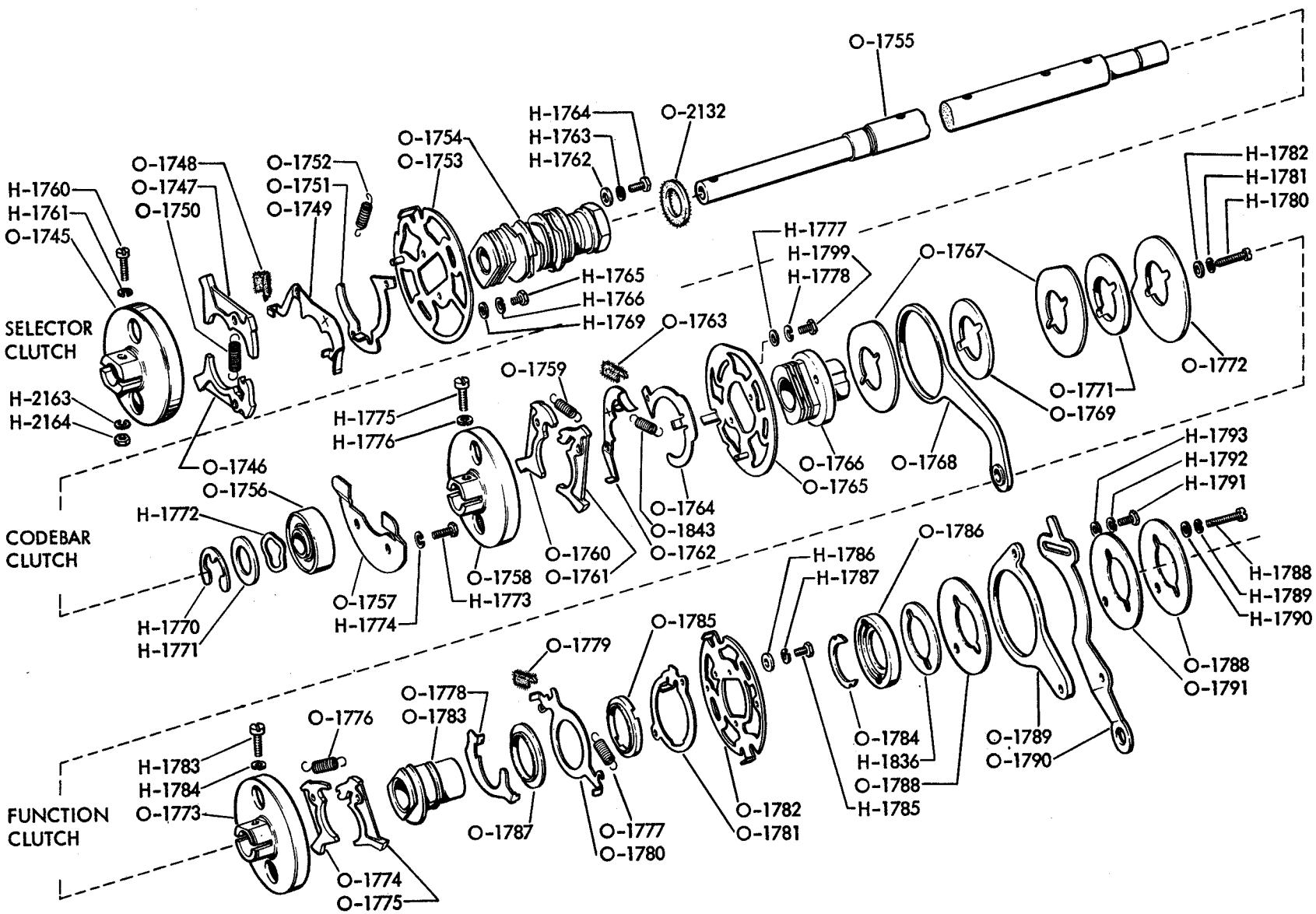


Figure 7-125. Automatic Typewriter, Main Shaft

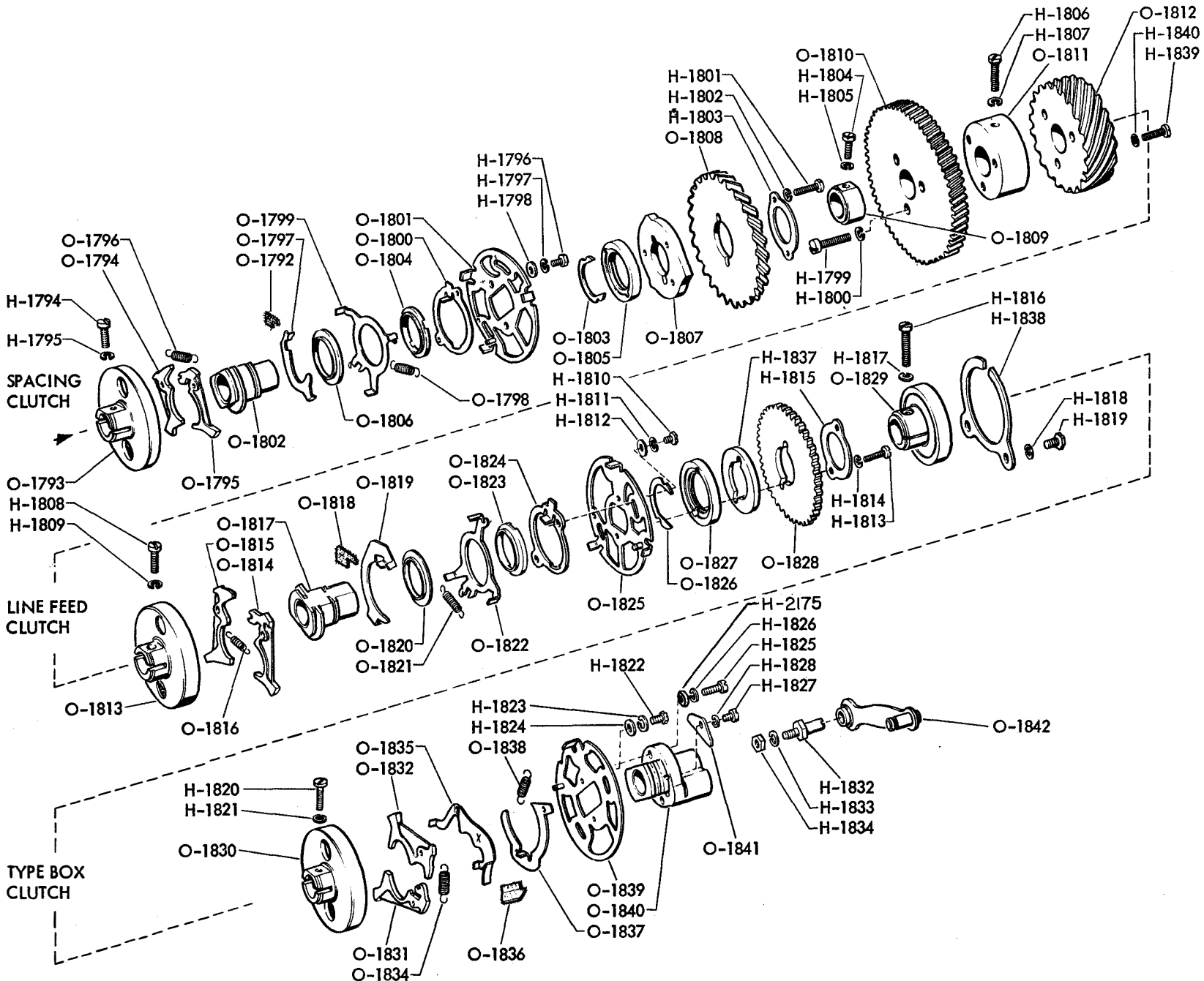
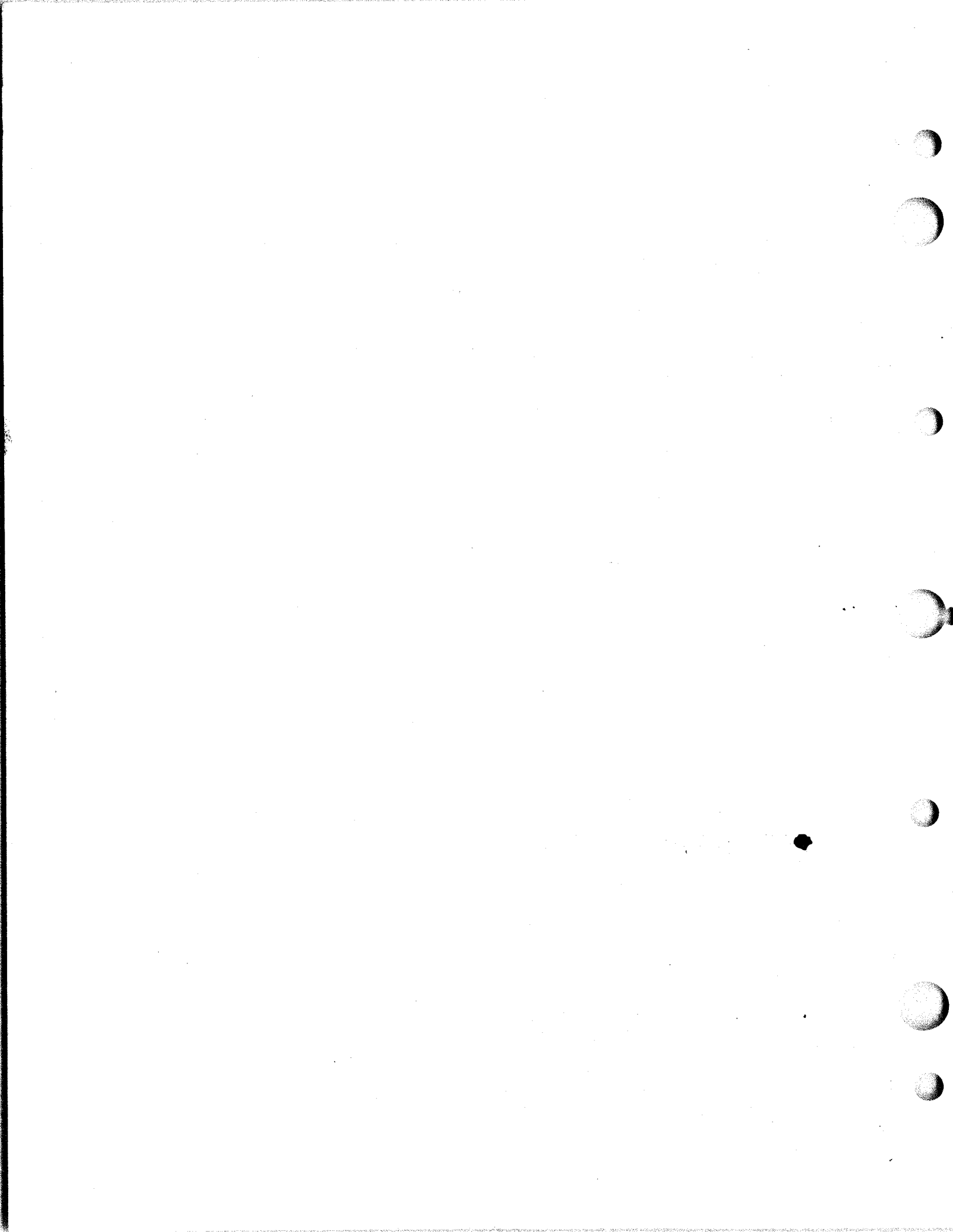


Figure 7-125A. Automatic Typewriter, Main Shaft

CHANGE 1

7-130A



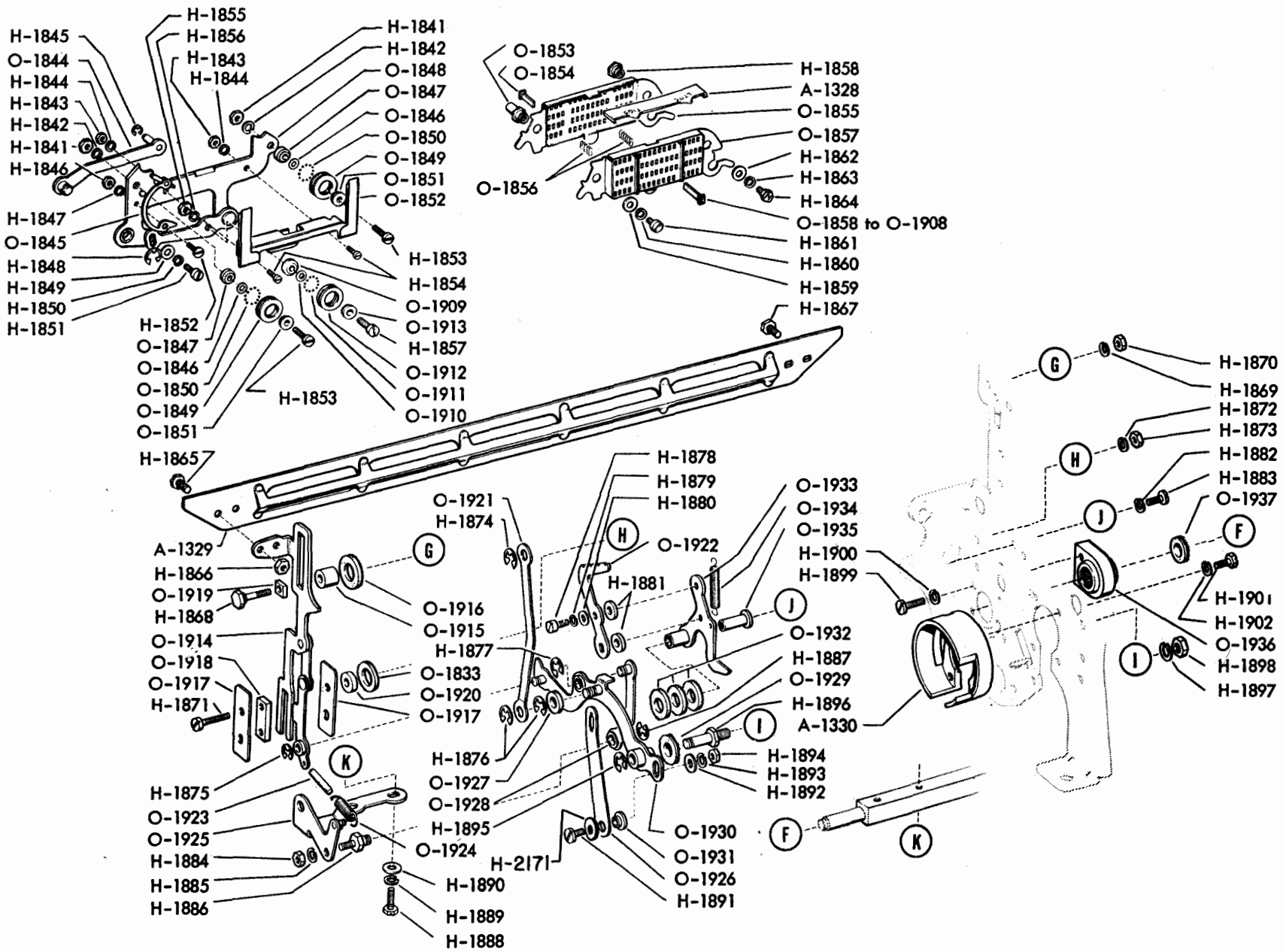


Figure 7-126. Automatic Typer, Right Side Linkage and Type Box

CHANGE 1

7-131

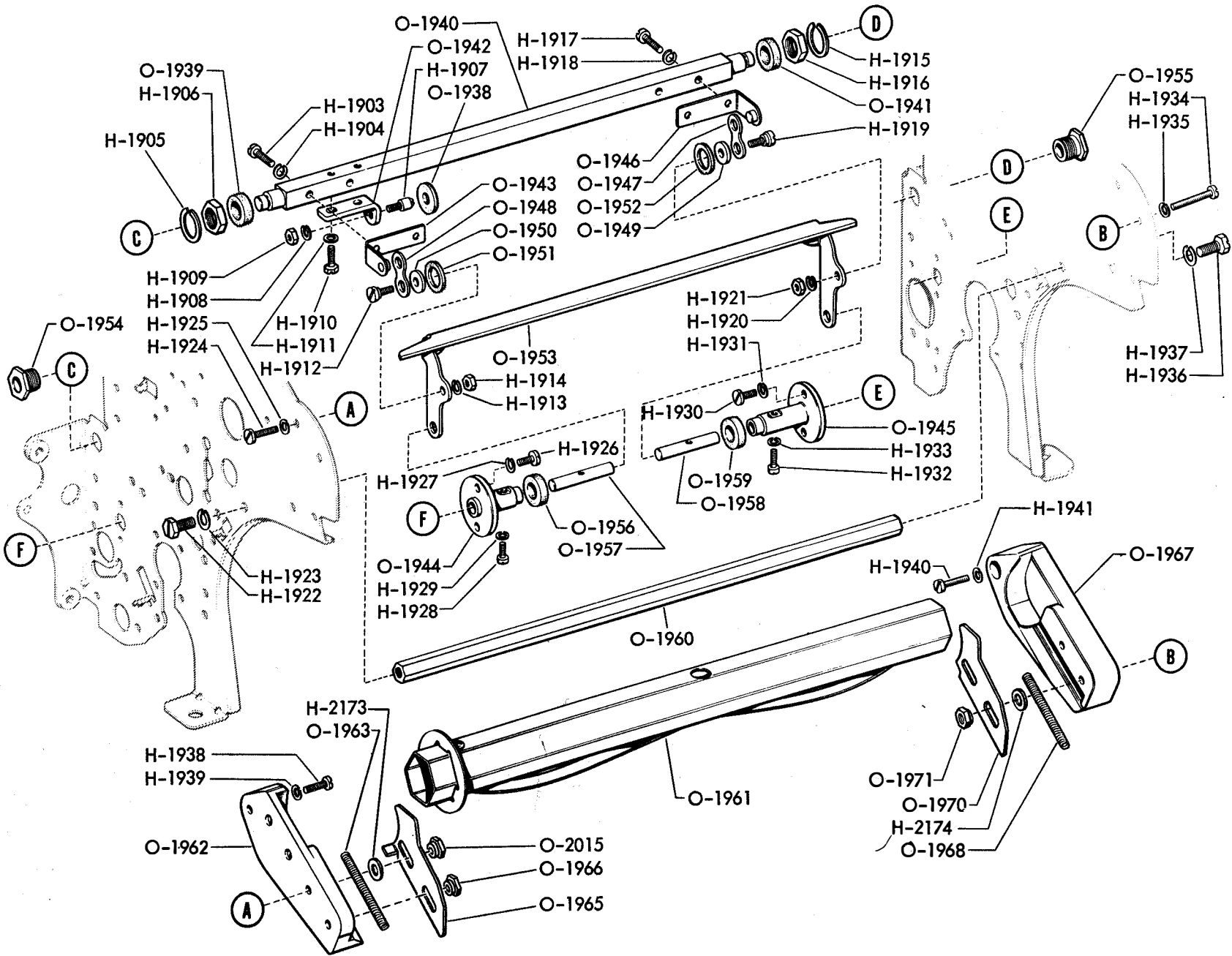


Figure 7-127. Automatic Typewriter Paper Spindle and Reset Bail

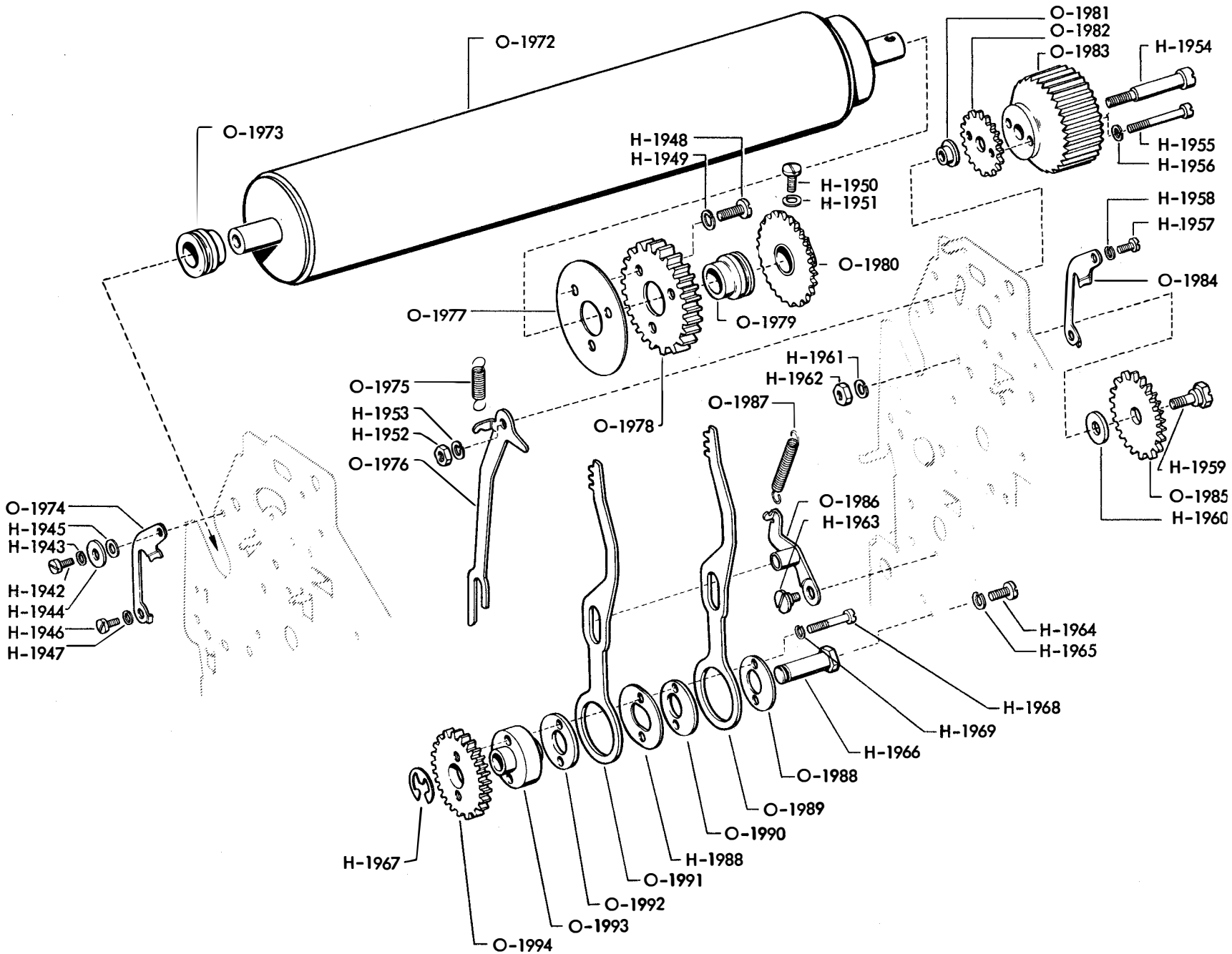


Figure 7-128. Automatic Typewriter, Line Feed and Platen Mechanism

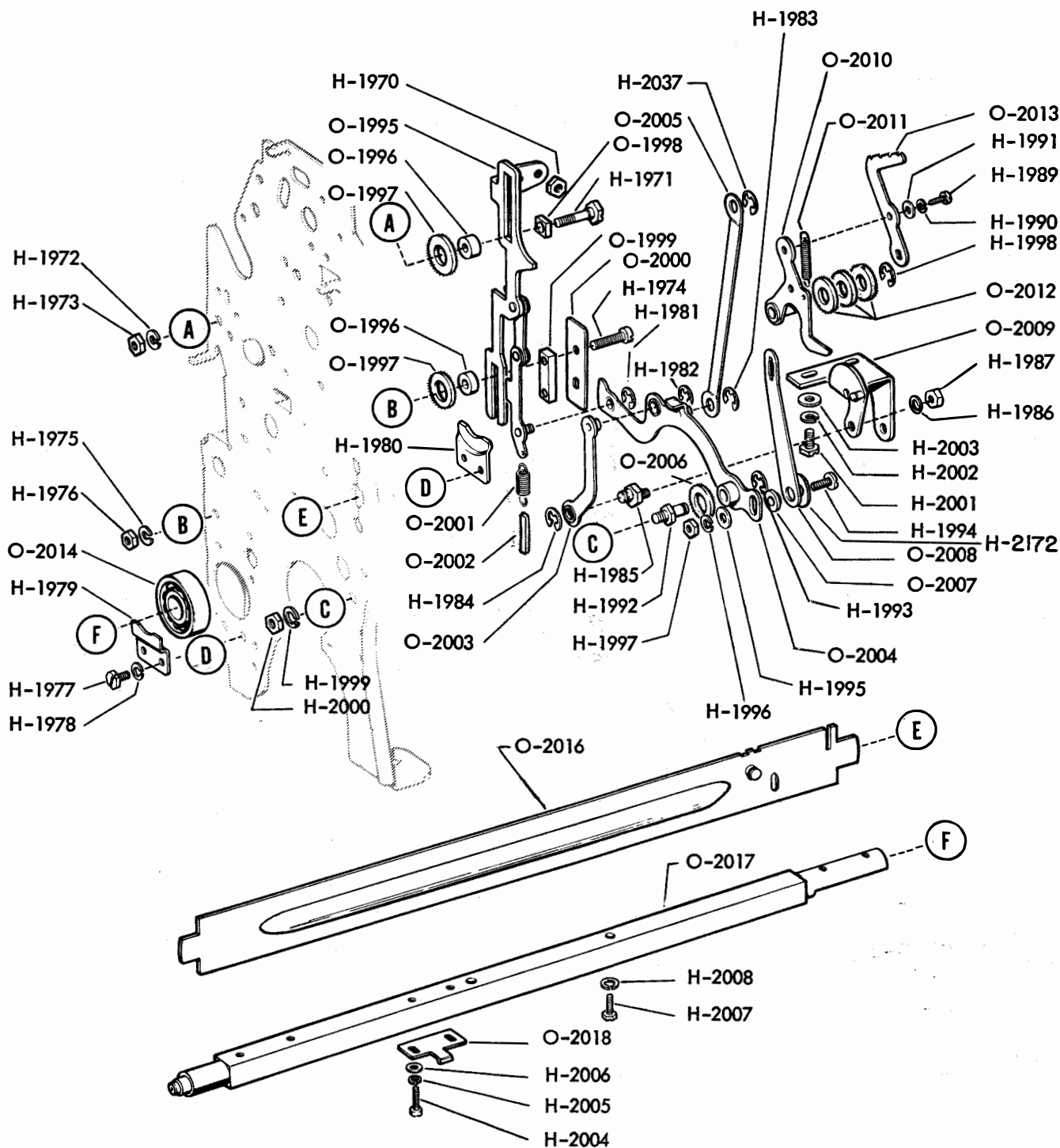


Figure 7-129. Automatic Typewriter, Left Side Linkage and Stripper Blade



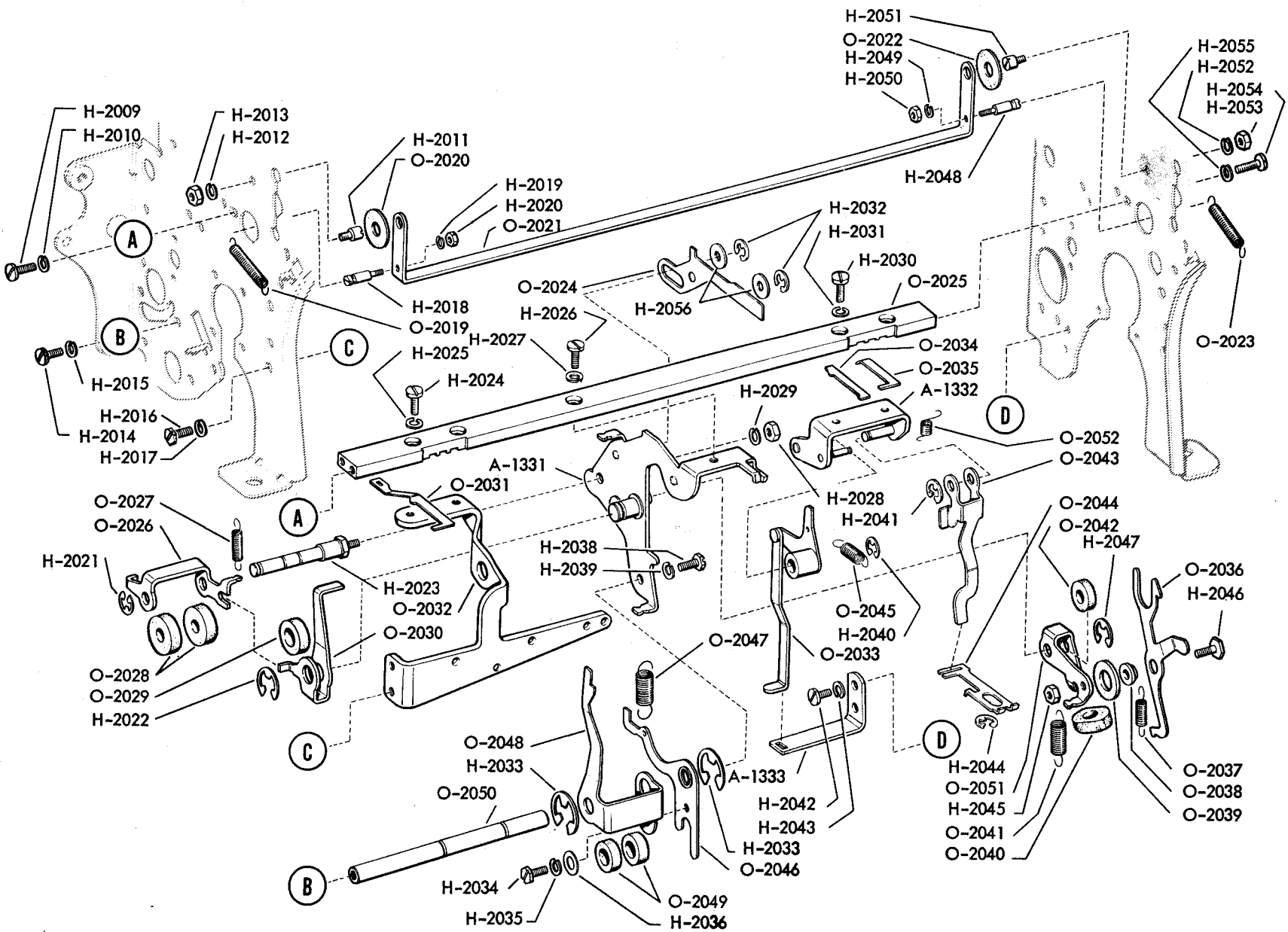


Figure 7-130. Automatic Typewriter, Space Suppression Mechanism

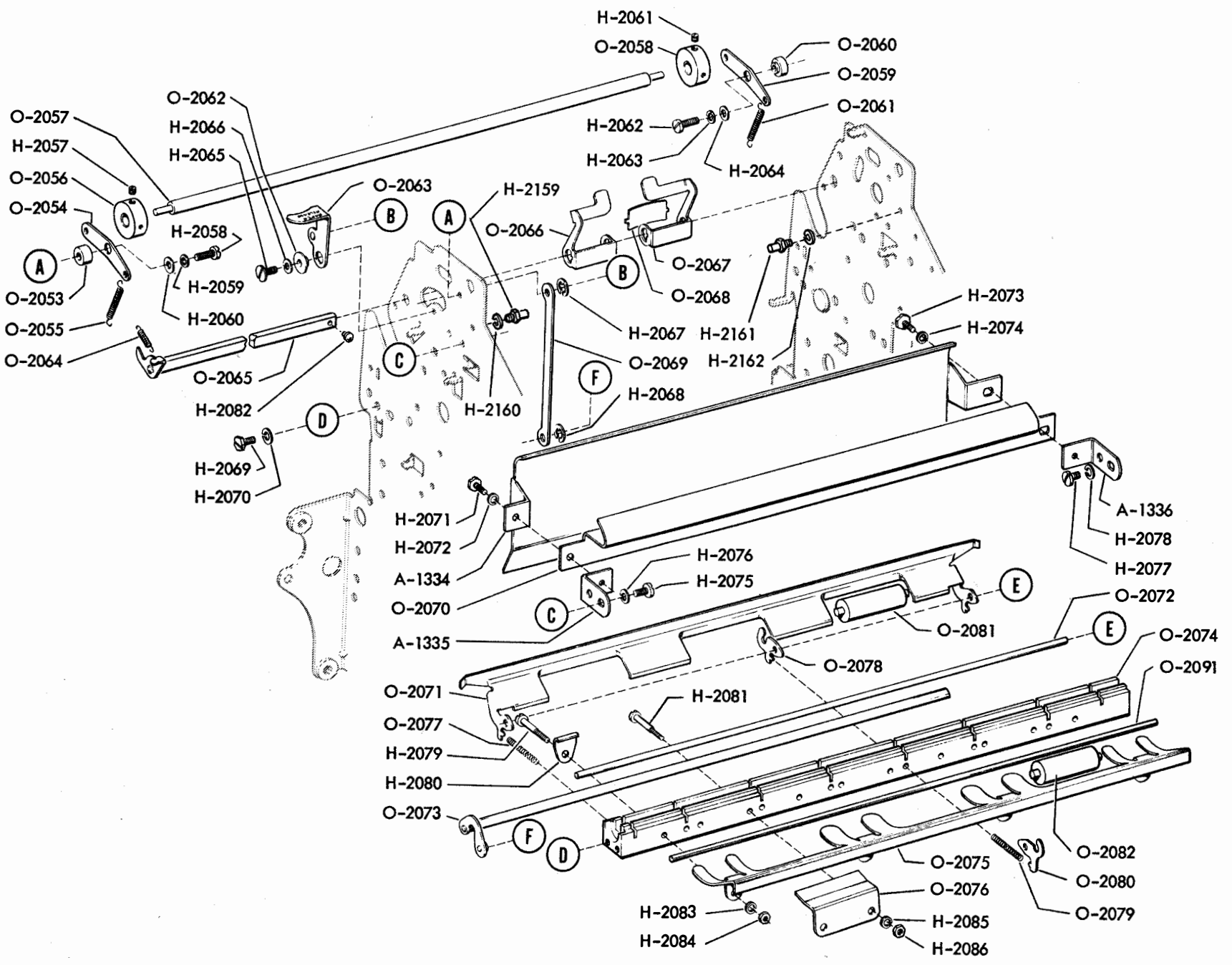


Figure 7-131. Automatic Typewriter Pressure Roller Mechanism

7-136

ORIGINAL

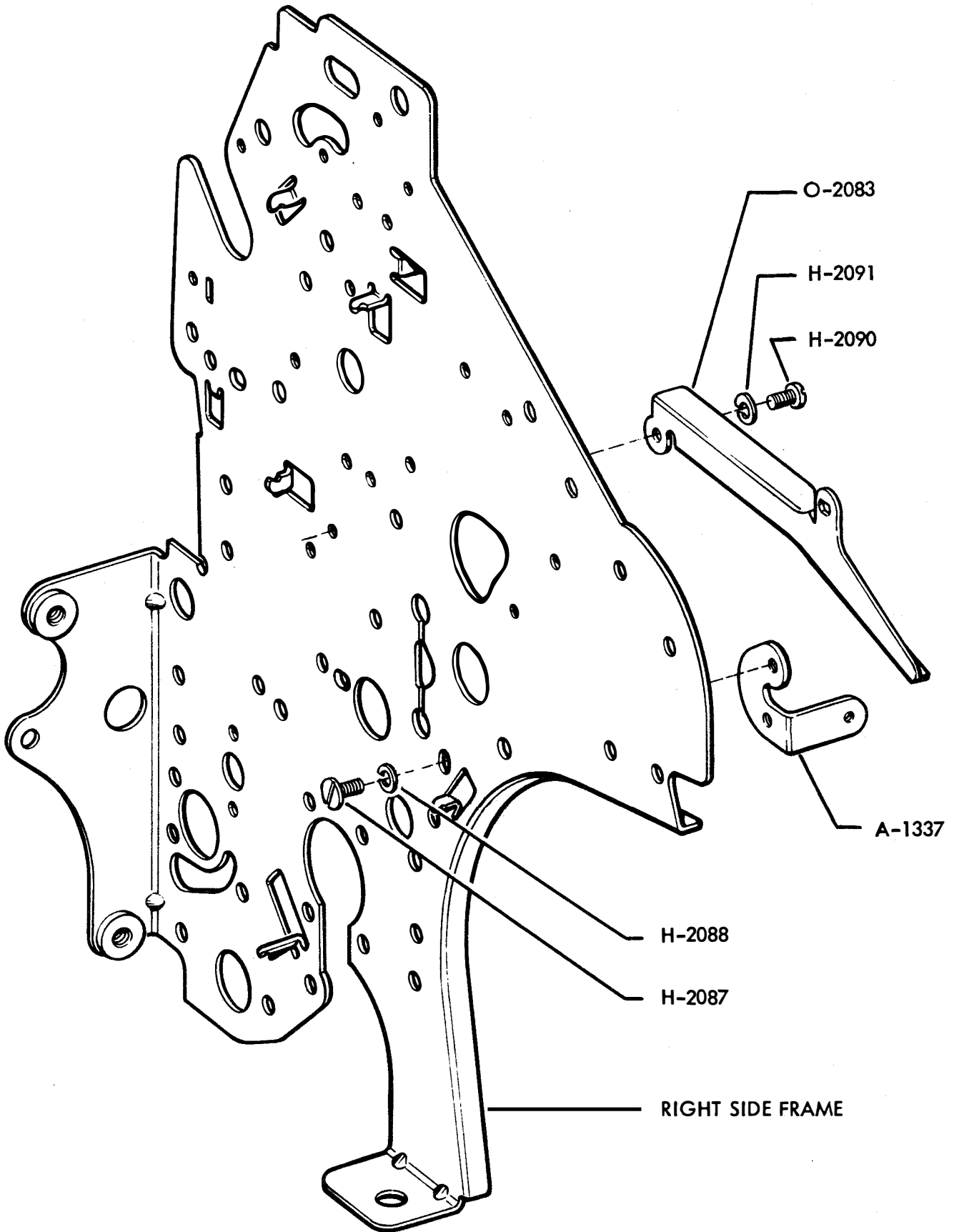


Figure 7-132. Automatic Typewriter, Right Side Frame Mechanism

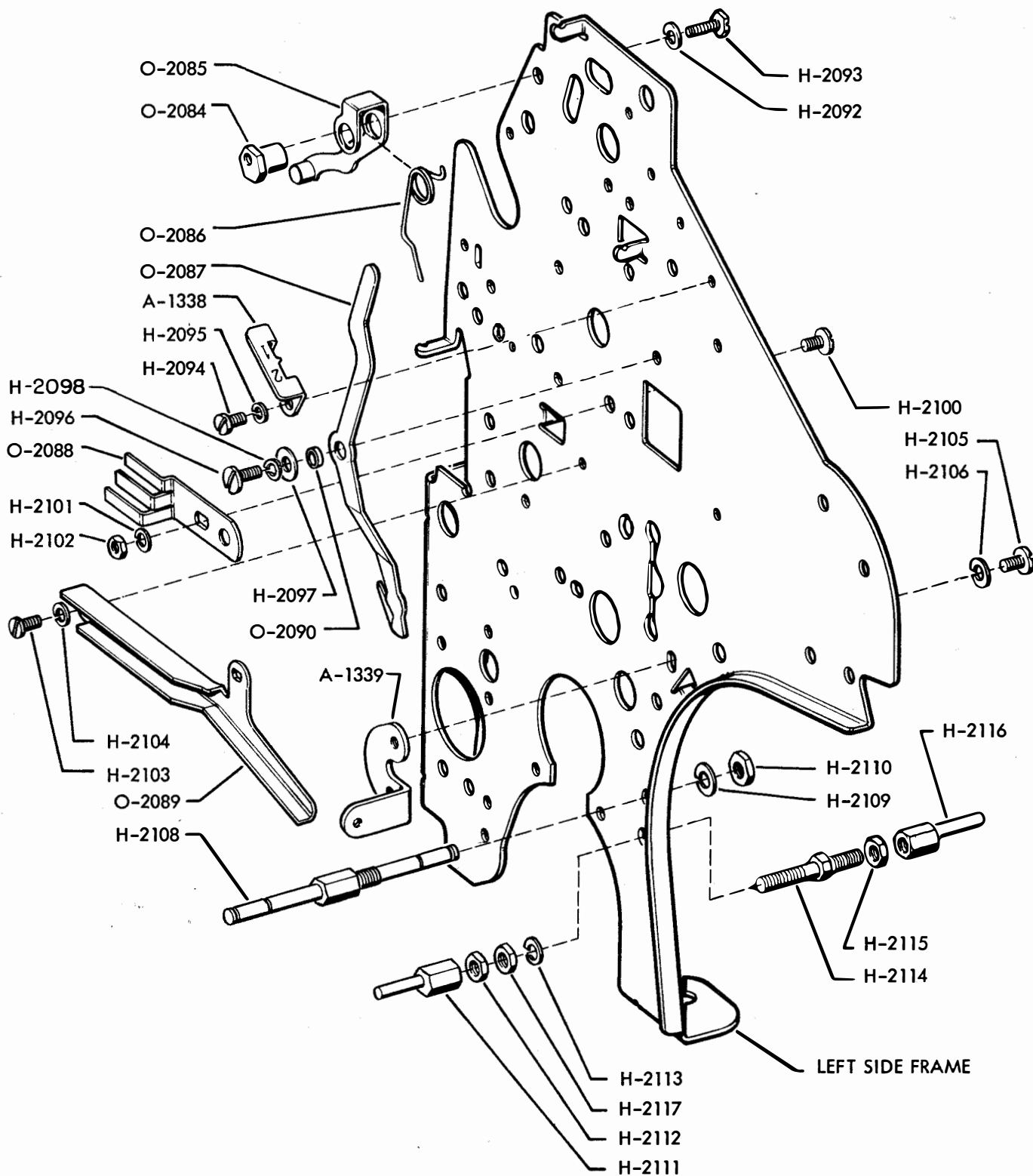


Figure 7-133. Automatic Typewriter, Left Side Frame Mechanism

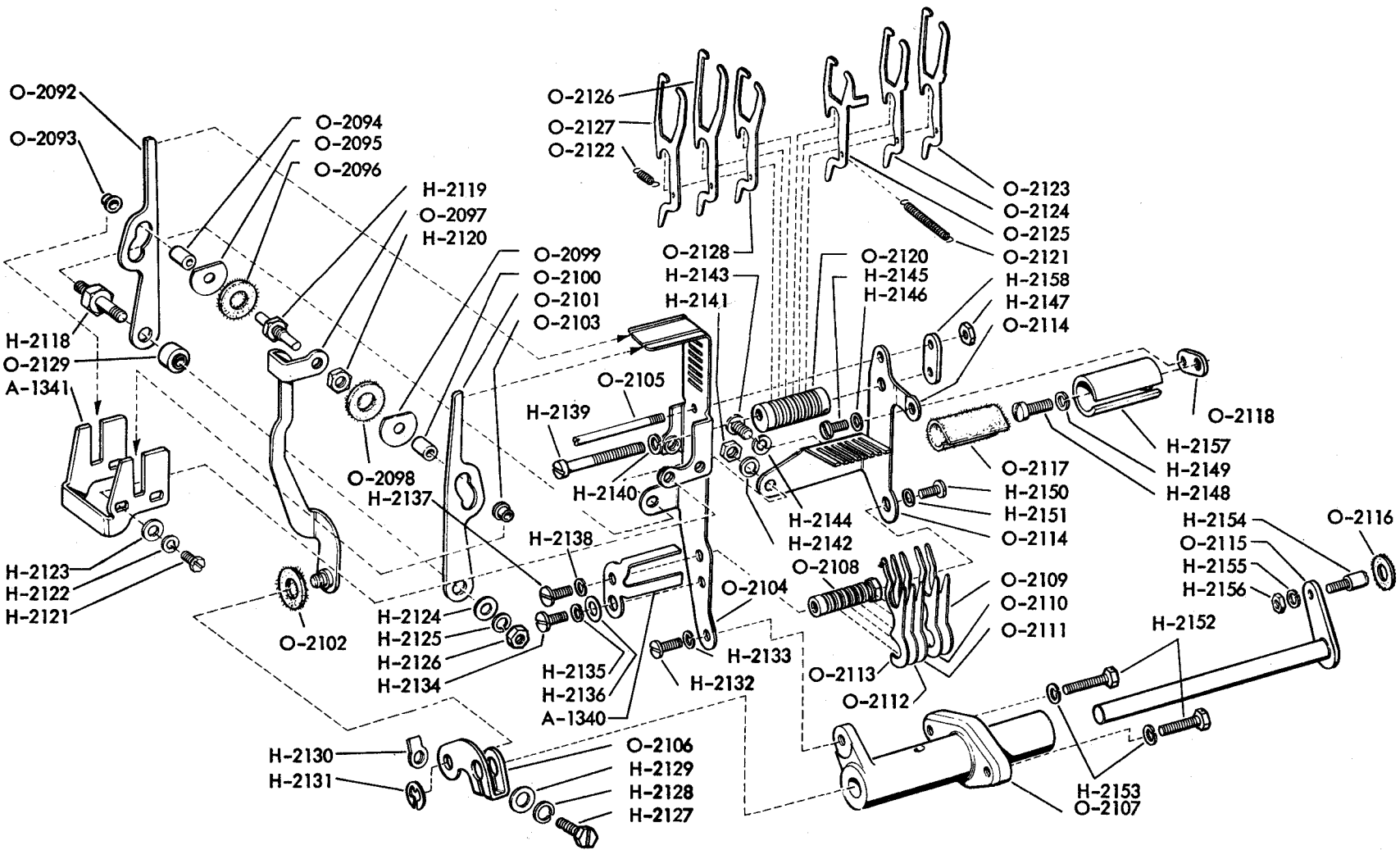


Figure 7-134. Automatic Typer, Code Bar Positioning Mechanism

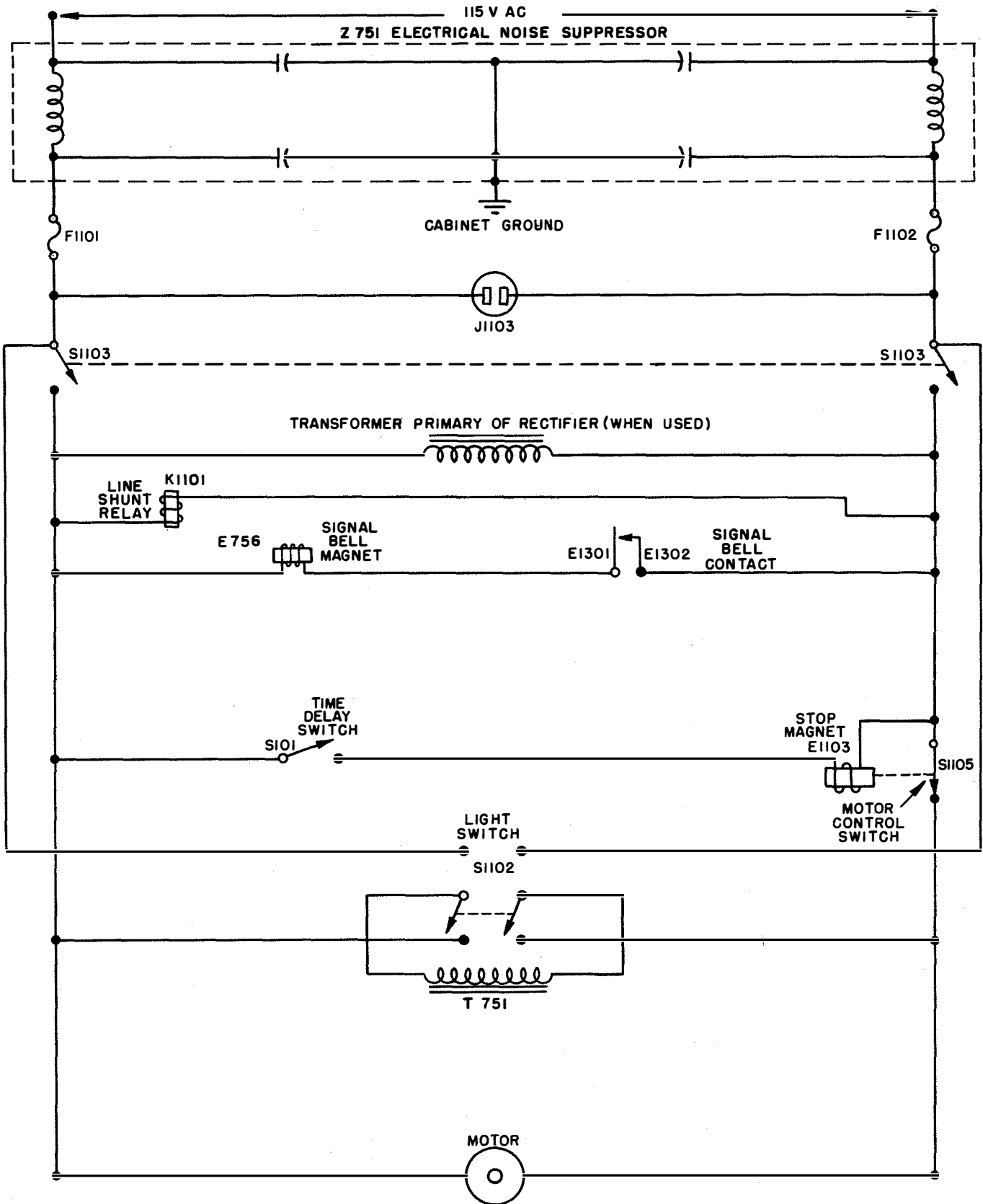


Figure 7-135. Primary Power Distribution Diagram

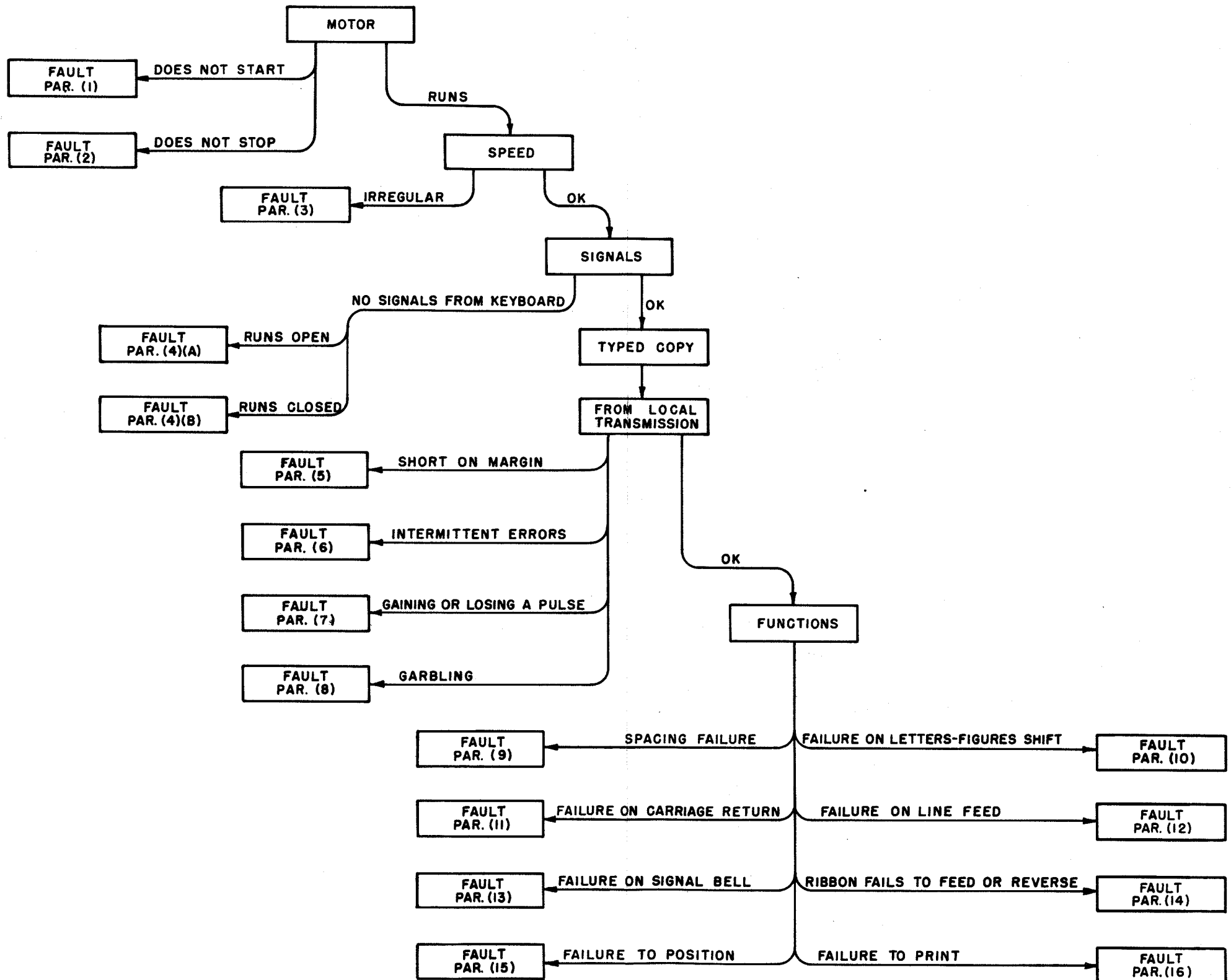
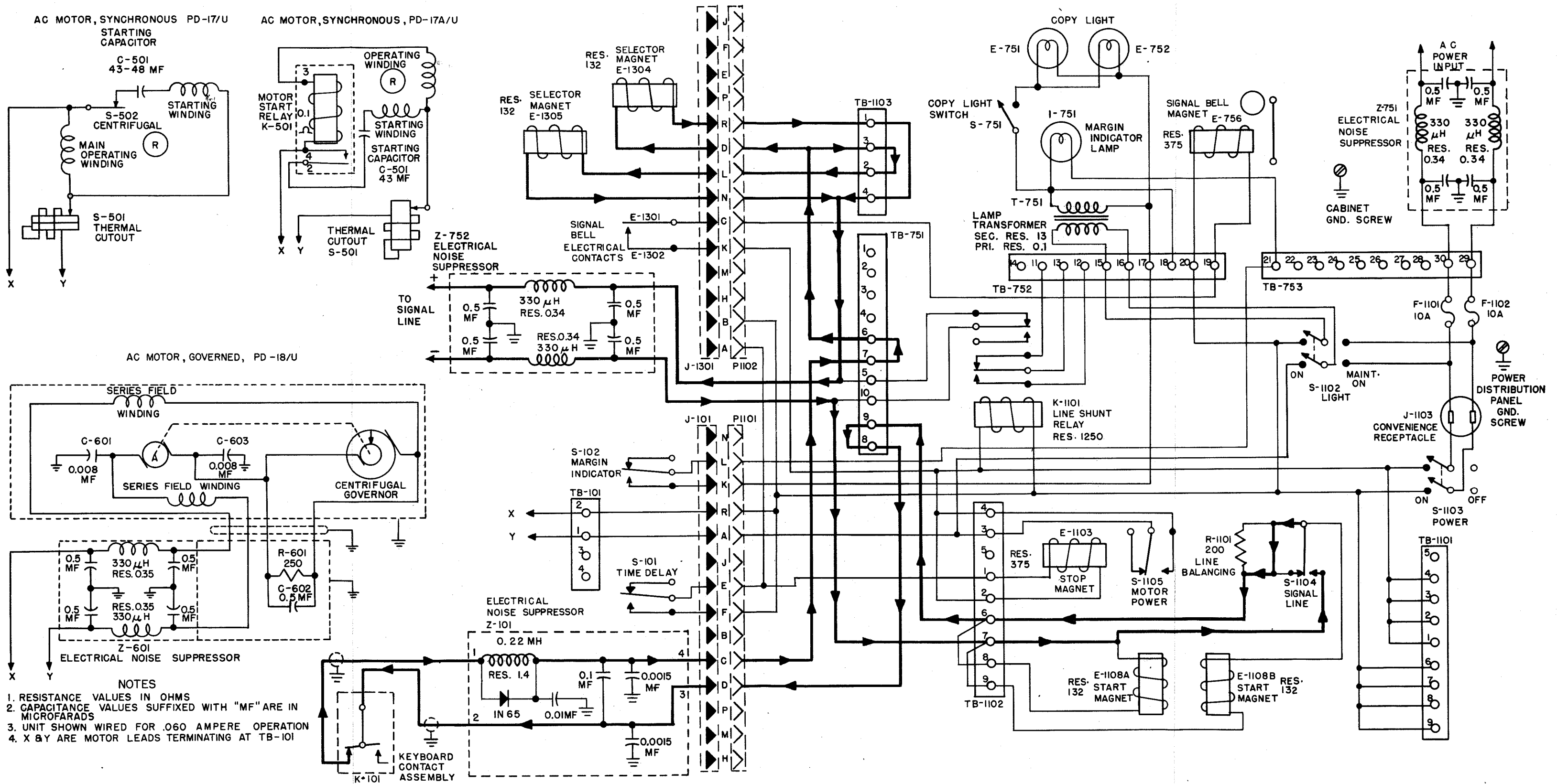


Table 7-4. Trouble Shooting Chart



- NOTES
1. RESISTANCE VALUES IN OHMS
  2. CAPACITANCE VALUES SUFFIXED WITH "MF" ARE IN MICROFARADS
  3. UNIT SHOWN WIRED FOR .060 AMPERE OPERATION
  4. X & Y ARE MOTOR LEADS TERMINATING AT TB-101

Figure 7-136. Schematic Wiring Diagram, TT-47/UG, TT-48/UG, TT-69/UG, & TT-70/UG



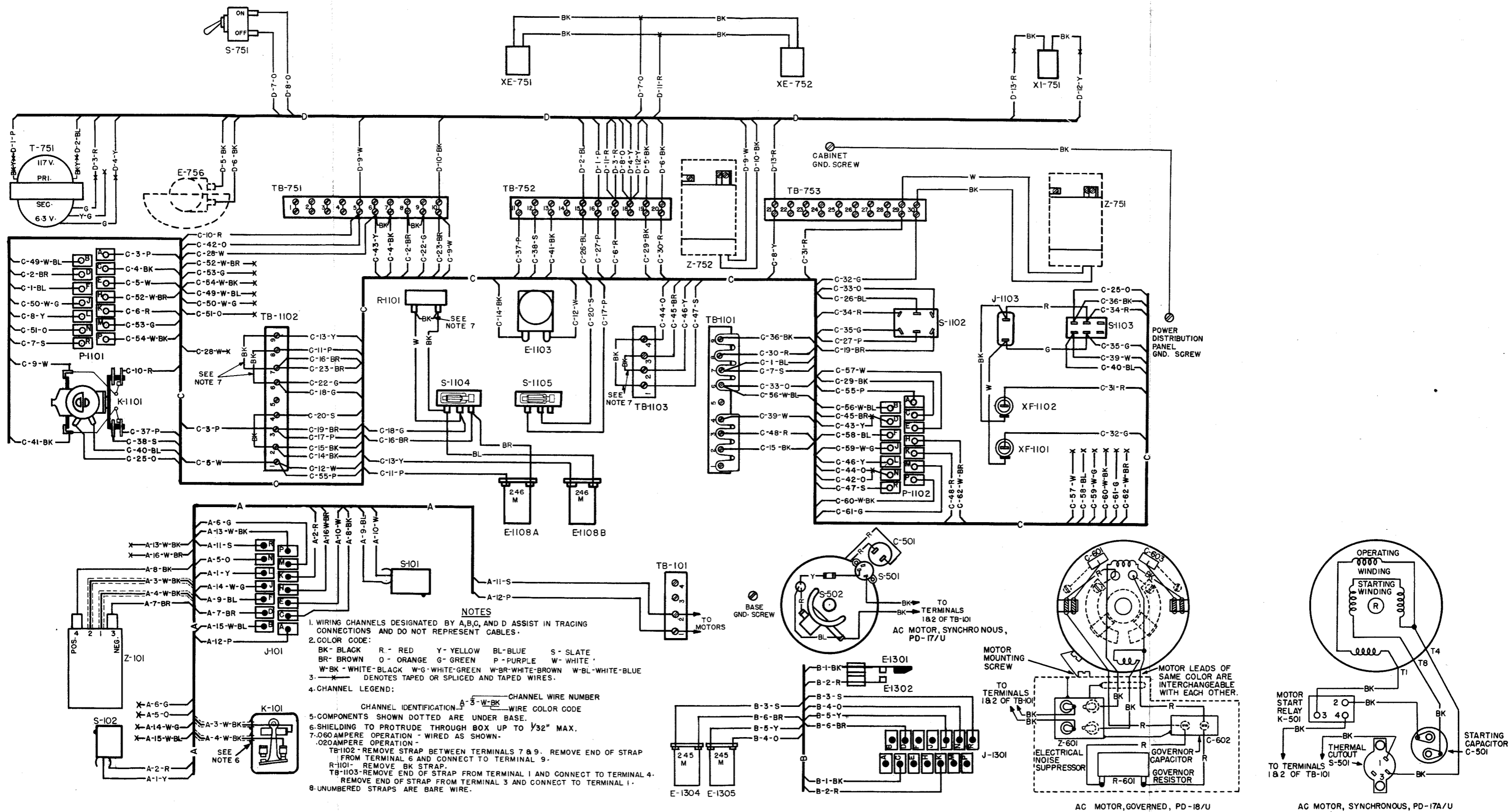


Figure 7-137. Wiring Diagram, TT-47/UG, TT-48/UG, TT-69/UG, & TT-70/UG

SECTION 8

PARTS LISTS

LIST OF TABLES

<i>Subject</i>	<i>Page</i>
Table 8-1 Weights and Dimensions of Spare Parts Boxes .....	8-2
Table 8-2 Shipping Weights and Dimensions of Spare Parts Boxes (Not Applicable) ...	8-2
Table 8-3 List of Major Units .....	8-2
Table 8-4 Combined Parts and Spare Parts List .....	8-4
Table 8-5 Cross Reference Parts List .....	8-192
Table 8-6 List of Manufacturers .....	8-198

TABLE 8-1. WEIGHTS AND DIMENSIONS OF SPARE PARTS BOXES

EQUIPMENT SPARES					
SPARE PARTS BOX	OVERALL DIMENSIONS IN INCHES			VOLUME CU. FT.	WEIGHT POUNDS
	HEIGHT	WIDTH	DEPTH		
1	21½	19½	7⅞	1.91	5

TABLE 8-2. SHIPPING WEIGHTS AND DIMENSIONS OF SPARE PARTS BOXES

NOT APPLICABLE

(Spare Parts Box Included in Unit Pack)

TABLE 8-3. LIST OF MAJOR UNITS

SYMBOL GROUP	QUANTITY	NAME OF MAJOR UNIT	NAVY TYPE DESIGNATION	STANDARD NAVY STOCK NUMBER
101-499	1	KEYBOARD	MX-1114/UG	
501-599	1	AC MOTOR	PD-17/U or PD-17A/U	
601-699	1	AC MOTOR	PD-18/U	
701-1099	1	CABINET	CY-870/UG	
701-1099	1	CABINET	CY-871/UG	
1101-1299	1	POWER DISTRIBUTION PANEL	SB-154/UG	
1301-2299	1	AUTOMATIC TYPER	MX-1115/UG	



TABLE 8-4. COMBINED PARTS AND SPARE PARTS LIST

SYMBOL DESIG.	NAME OF PART AND DESCRIPTION	FUNCTION	JAN OR NAVY TYPE DESIGNATION	STANDARD NAVY STOCK NUMBER	MANUFAC- TURERS		TELETYPE PART NO.	ALL SYMBOL DESIGNATIONS INVOLVED	SPARE PARTS				
					CODE	DESIG.			TOTAL NO. PER EQUIP.	EQUIP.		STOCK	
										BOX	QUAN.	BOX	QUAN.
A-101	BRACKET: irregular shape; steel, nickel plated; approx 2 7/8" lg x 1 11/16" wd x 1 1/16" h o/a, 0.065" thk material; mts by body hole in rounded formed ear and in formed side; two formed sides, rectangular shaped slot and tapped hole in mtg side, other side has elongated cutout and body hole, two formed ears, one rounded w/body hole, other squared w/tapped hole, rounded body ear and extended body ear w/body hole in ea, two body holes and elongated slot in body.	Mounts time delay mechanism		N17-T-350013-684	CTT	151231	151231	A-101	1	-	-	-	-
A-102	BRACKET: irregular shape, one end formed w/rounded ear; steel, nickel plated; approx 27/32" lg x 7/8" wd x 1/4" h o/a, 0.065" thk material; mts by two #4-40 holes in wd end; body hole in ear	Adjustable mount for A-105		N17-T-350014-712	CTT	151191	151191	A-102	1	-	-	-	-
A-103	BRACKET: irregular shape w/one end formed and two formed ears, one "V" notched; steel, nickel plated; approx 1 9/16" lg x 1 1/8" h x 13/16" wd o/a, 0.065" thk material; mts by two tapped holes in formed side and two tapped holes in body; tapped hole in rounded end	Mounts S-102 and O-124		N17-T-350013-708	CTT	151342	151342	A-103	1	-	-	-	-
A-104	BRACKET: irregular shape; steel, nickel plated; approx 1 3/8" lg x 1 1/32" wd x 1 5/16" h o/a, 0.050" thk material; mts by two body holes; three formed ears, largest one has two slots and csk hole, one has slot, other has elongated hole	Mounts and guides locking and release mechanism for O-134		N17-T-350014-487	CTT	151167	151167	A-104	1	-	-	-	-
A-105	BUMPER: sirvene; approx 3/16" thk x 1/4" diam o/a; mts by 1/8" diam shank	Stop for O-239		N17-T-350014-574	CHICAGO RAWIDE CO. #3102 Sirvine		151193	A-105, A-117	2	1	5	-	-
A-106	FRAME: aluminum, plain anodize; irregularly shaped and notched; approx 9 5/8" lg x 1 5/8" h x 3 3/8" wd o/a; mts by tapped hole in ea corner; large cutout in ctr, 3 cutouts and 3 ears—two w/tapped holes and 1 w/body hole on 1 side, arm w/squared ear w/tapped hole on ea end of other side, two body arms one end, two body and two tapped holes in ea end	Mounts code lever mechanism		N17-T-350014-453	CTT	151092	151092	A-106	1	-	-	-	-
A-107	BRACKET: rectangular shape; steel, nickel plated; approx 1 5/16" lg x 15/32" h x 3/16" thk o/a; mts by two body holes; cutout along one side	Locks O-143 and O-142 to A-106		N17-T-350014-403	CTT	151029	151029	A-107	1	-	-	-	-

8-4

CHANGE 1

## PARTS LISTS

NAVSHIPS 91393

TT-47/UG, TT-48/UG, TT-69/UG, TT-70/UG

Section 8  
A-108-A-118

A-108	BRACKET: "U" shape; steel, nickel plated; approx 1 1/4" lg x 1" h x 15/16" wd o/a; 0.065" thk material; mts by two tapped holes in bottom; sides curved over w/two body holes in line at ends	Pivot support for O-209	N17-T-350014-434	CTT	151107	151107	A-108, A-111	2	-	-	-	-	-
A-109	BRACKET: "U" shape; steel, nickel plated; approx 1 1/4" lg x 13/16" h x 1/2" wd o/a, 0.065" thk material; mts by two tapped holes in bottom of "U"; two body holes in line in sides of "U"	Pivot support for O-217	N17-T-350014-473	CTT	151147	151147	A-109	1	-	-	-	-	-
A-110	BRACKET: irregular "U" shape; steel, nickel plated; approx 1 1/4" lg x 1 7/32" h x 15/16" wd o/a, 0.065" thk material; mts by two tapped holes in bottom of "U"; irregular shaped elongated hole in longer side, body hole csk both sides in other side	Guide for O-219	N17-T-350014-491	CTT	151159	151159	A-110	1	-	-	-	-	-
A-111	Same as A-108	Pivot support for O-121											
A-112	COVER: iron, nickel plated; approx 1 3/4" lg x 1 3/8" wd x 5/32" h o/a, 0.025" thk material; mts by body hole and edges; 1/8" letters "DO NOT OIL" stamped on top; one body slot	Cover for contact mechanism	N17-T-350013-715	CTT	151359	151359	A-112	1	-	-	-	-	-
A-113	BRACKET: "U" shape; steel, nickel plated; approx 3 15/16" lg x 1 1/8" h x 13/16" wd o/a, 0.065" thk material; mts by two tapped holes in bottom of "U"; tapped hole in ea side of "U" at end	Mounts O-227	N17-T-350013-681	CTT	151227	151227	A-113	1	-	-	-	-	-
A-114	FRAME: steel, nickel plated; irregular shaped w/2 formed edges and 1 formed side; approx 13 3/4" lg x 3 3/16" wd x 3 3/4" h o/a, 0.065" thk material; mts by 4 tapped holes; 13 tapped, 6 round, and 2 elongated body holes, elongated cutout in body and formed side	Mounts keytop guide plate and A-115	N17-T-350013-699	CTT	151323	151323	A-114	1	-	-	-	-	-
A-115	TRACK: c/o track lock plate and screws; steel, nickel plated; approx 13 1/4" lg x 1" wd x 5/16" dp o/a; mts by hole at each end of lock plate; 42 slots and two tapped holes top p/o lock plate, body hole, tapped hole and elongated hole in line through track and lock plate	Guide for code bar levers and mounts O-231		CTT	151070	151070	A-115	1	-	-	-	-	-
A-116	PLATE, sealing: c/o plate within Sirvene cover; steel plate, Sirvene covered; oblong shaped with elongated hole 8 3/16" lg x 3 3/4" wd, 13 body holes 5/32" diam embossed to 5/16" diam; approx 17 1/4" lg x 4 3/4" wd x 7/16" thk o/a; mts by 3 holes along top, two holes below elongated opening and 2 end holes ea end; pointed sealing edge around perimeter	Mounts A-114 to keyboard	N17-T-350013-700	CTT	151326	151326	A-116	1	-	-	-	-	-
A-117	Same as A-105	Stop for O-257											
A-118	FRAME: aluminum, plain anodize; irregular shaped w/"L" shaped arm, straight arm other side, 2 irregular elongated slots in body; approx 7 5/16" lg x 1 5/8" h x 5 5/8" wd o/a; mts by 4 tapped holes; 9 tapped and 5 body holes	Mounts signal generator mechanism	N17-T-350013-701	CTT	151328	151328	A-118	1	-	-	-	-	-

CHANGE 1

8-5

TABLE 8-4. COMBINED PARTS AND SPARE PARTS LIST

SYMBOL DESIG.	NAME OF PART AND DESCRIPTION	FUNCTION	JAN OR NAVY TYPE DESIGNATION	STANDARD NAVY STOCK NUMBER	MANUFACTURERS		TELETYPE PART NO.	ALL SYMBOL DESIGNATIONS INVOLVED	TOTAL NO. PER EQUIP.	SPARE PARTS				
					CODE	DESIG.				EQUIP.		STOCK		
										BOX	QUAN.	BOX	QUAN.	
A-119	BRACKET: irregular shape; steel, nickel plated; approx 1 11/32" lg x 25/32" h x 15/32" wd o/a, 0.035" thk material; mts by two elongated slots in body; one end formed w/elongated slot and rounded ear w/body hole, curved cutout and rectangular shaped extension w/tapped hole on other end	Guide for O-281		N17-T-350014-576	CTT	151204	151204	A-119	1	-	-	-	-	
A-120	BRACKET: "L" shaped; steel, nickel plated; approx 2 1/4" lg x 3/4" h x 3/8" wd o/a, 0.050" thk material; mts by two elongated body slots; elongated cutout in body and arm, one curved and 1 rectangular ear on body, 2 body holes in rectangular ear	Mounts contact mechanism to signal generator		N17-T-350014-481	CTT	151178	151178	A-120	1	-	-	-	-	
A-121	BASE: molded black bakelite; irregular shape w/4 various levels; approx 1 3/16" lg x 9/16" h x 7/8" wd o/a; mts by tapped body hole; 2 body slots, 1 "U" shaped groove, 3 tapped body holes, elongated curved cutout near one end	Mounts contact mechanism		N17-T-350014-483	CTT	151176	151176	A-121	1	-	-	-	-	
A-122	BRACKET: "U" shape w/two ears; steel, nickel plated; approx 12 5/8" lg x 1 1/4" wd x 3 1/8" h o/a, 0.065" thk material; mts by elongated hole in ea ear	Guards signal generator mechanism		N17-T-350014-585	CTT	151399	151399	A-122	1	-	-	-	-	
A-501	COVER: aluminum, plain anodize; irregular shape, curved on top w/cutout near one end, lip around bottom, dished from bottom; approx 4 3/4" lg x 1 5/8" wd x 1 1/4" h o/a; mts by elongated cutout at each end	Cover for and holds C-501 to O-501		N17-C-945001-855	CG	111B-278AA-P1	122250	A-501	1	-	-	-	-	
A-502	HOUSING: aluminum, plain anodized; approx 3 1/2" OD x 3/8" ID x 1 3/4" lg o/a; mts by two body holes; dished out one side, short end of hub cutout one side w/body hole to ID	Mounts S-503 and shield and cover for S-503 and S-502		N17-T-350013-807	CTT	122246	122246	A-502	1	-	-	-	-	
A-503	BRACKET: "U" shape w/elongated bottom; steel, nickel plated; approx 6 3/16" lg x 3 3/8" wd x 2 1/4" h o/a, 0.095" thk material; mts by body hole in ea corner ear; 2 large rectangular holes in base, irregular shaped large cutout and three small cutouts in ea end	Mounts PD-17/U		N17-T-350013-895	CTT	151168	151168	A-503	1	-	-	-	-	
A-504	PLATE, mounting; steel, nickel plated; approx 4 5/8" lg x 2 1/4" wd x 0.042" thk o/a, mts by four corner holes; curved cutout one side, 2 large and 6 small body holes irregularly spaced	Mounting plate for C-501, K-501, and S-501			CTT	151920	151920	A-504	1	-	-	-	-	
A-505	BRACKET ASSEMBLY: c/o 2 brackets welded together; steel, nickel plated; irregular shape upper bracket has 2 formed ends w/cutout in ea, 4 body ears, 4 tapped holes, and rectangular cutout in ctr, lower bracket "U" shape w/3 elongated holes in one side and 2 body holes in ea side, 4 tapped holes through both brackets; approx 6 3/16" lg x 3 3/8" wd x 3 11/16" h o/a; mts by body hole in ea corner ear	Mounts PD-17A/U		N17-T-350013-893	CTT	150976	150976	A-505	1	-	-	-	-	

CHANGE 1

## PARTS LISTS

## NAVSHIPS 91393

TT-47/UG, TT-48/UG, TT-69/UG, TT-70/UG

Section 8  
A-601—A-613

A-601	COVER: aluminum, plain anodized; approx 3 1/4" OD x 1 1/8" deep o/a, 0.040" thk material; mts by two tapped holes; exterior painted white w/4, 6 and 35 black segments, in rows, forming 8, 12 and 70 equal divisions on OD; body hole in OD w/"P" and "S" on ea end of curved arrow stamped around hole	Cover for all mounted parts of B-601	N17-T-350014-384	CTT	150879	150879	A-601	1	-	-	-	-	-
A-602	BRACKET: "L" shaped w/guide welded to narrow side; steel, nickel plated; approx 1 1/16" lg x 1 1/16" h x 5/8" wd o/a, 0.065" thk material; mts by two body holes in wide end of "L"; guide has strip w/hole across ID on mtd end, lg slot other end, tapped hole below guide	Mounting base and guide for O-604	N17-T-350014-383	CTT	150877	150877	A-602	1	-	-	-	-	-
A-603	BRACKET: contact support; "L" shape w/formed ear on lg side; steel, nickel plated; approx 1 9/32" h x 19/32" wd x 1 5/32" lg o/a, 0.065" thk material; mts by 2 body holes in lg end; tapped hole in short end and body hole in formed ear	Mounts E-606	N17-T-350014-377	CTT	150859	150859	A-603	1	-	-	-	-	-
A-604	BRACKET: contact screw support; irreg shape, one end formed, formed ear on wd end; steel, nickel plated; approx 1 5/8" lg x 3/4" h x 5/8" wd o/a, 0.065" thk material; mts by two body holes in wd end of body; elongated slot in formed end and body hole in formed ear	Mounts E-617	N17-T-350014-376	CTT	150858	150858	A-604	1	-	-	-	-	-
A-605	PLATE, brush: nickel silver; approx 1 3/4" lg x 1 1/8" wd x 1/8" thk o/a; mts by hole in ea formed ear; irregular curved shape w/two formed ears, elongated slot in ctr of body	Holds E-601 on A-606	N17-T-350014-316	CTT	150885	150885	A-605, A-608	2	-	-	-	-	-
A-606	MOUNTING, brush holder: black bakelite; approx 2 1/2" lg x 1 1/4" wd x 1/2" thk o/a; mts by 4 body holes; curved body w/two round ears ea side, irregularly grooved and 2 body holes	Guide for E-601	N17-T-350014-315	CTT	150884	150884	A-606, A-609	2	-	-	-	-	-
A-607	PLATE, clamp: steel, nickel plate, round ends; approx 7/8" lg x 1/4" wd x 0.065" thk o/a; mts by two tapped holes	Nut plate for H-606	N17-T-350014-317	CTT	150886	150886	A-607, A-610	4	-	-	-	-	-
A-608	Same as A-605	Holds E-602 on A-609											
A-609	Same as A-606	Guide for E-602											
A-610	Same as A-607	Nut plate for H-616											
A-611	BRACKET: motor support; "U" shape; steel, nickel plated; approx 6 3/16" lg x 3 3/8" wd x 2 9/32" h o/a, 0.095" thk material; mts by body hole in ea corner; rectangular shaped hole, 2 cutouts and 11 tapped holes in base, irregularly cutout in both ends	Mounts PD-18/U to keyboard base		CTT	152046	152046	A-611	1	-	-	-	-	-
A-612	COVER: brass, nickel plated; closed one end, one cutout and 10 slots other end, one rectangular hole, 8 sq holes and one tapped hole in circum, #40 mesh screen soldered to inside of circum; approx 3 11/16" diam x 2 3/4" lg o/a; mts by lip and four body holes in circum	Cover and electrostatic shield for governor mechanism		CTT	152044	152044	A-612	1	-	-	-	-	-
A-613	COVER: steel and brass, nickel plated; #40 screen sandwiched between 2 plates, cutout in ctr, and welded together, grommet and washer fastened to screen; approx 4 3/4" lg x 3 3/8" wd x 3/32" thk o/a; mts by 11 body holes; 11 depressions one side	Cover for and electrostatic shield for mounted parts of A-615		CTT	152037	152037	A-613	1	-	-	-	-	-

CHANGE 1

8-7



TABLE 8-4. COMBINED PARTS AND SPARE PARTS LIST

PARTS									SPARE PARTS				
SYMBOL DESIG.	NAME OF PART AND DESCRIPTION	FUNCTION	JAN OR NAVY TYPE DESIGNATION	STANDARD NAVY STOCK NUMBER	MANUFAC- TURERS		TELETYPE PART NO.	ALL SYMBOL DESIGNATIONS INVOLVED	TOTAL NO. PER EQUIP.	EQUIP.		STOCK	
					CODE	DESIG.				BOX	QUAN.	BOX	QUAN.
A-614	BRACKET: resistor support; "L" shape; steel, nickel plated; approx 2 1/16" lg x 1/2" wd x 23/32" h o/a, 0.050" thk material; mts by 2 #4-40 holes 7/16" c to c in irregular shape short end	Mounts R-603 to A-615			CTT	152034	152034	A-614	2	-	-	-	-
A-615	BASE, motor: steel, nickel plated; irregular shape, partially enclosed on top w/4 formed flaps around opening, completely open on bottom w/3 sides formed to receive slide cover, 3 cutouts, 2 covered w/#40 brass screen; approx 4 3/4" lg x 4 5/16" wd x 1 17/32" h o/a, 0.016" thk material; mts by 11 body holes in flaps; one tapped hole in disc welded to side and 3 body holes in sides	Container for C-602, R-603, and Z-601			CTT	152039	152039	A-615	1	-	-	-	-
A-616	COVER: steel, nickel plated; rectangular shape, cutout and 2 formations on one side, gray fibre insulator riveted to larger formation, body hole in smaller formation, 9 extrusions along other 3 sides, #40 brass screen soldered over rectangular cutout in body; approx 3 15/16" lg x 3 3/4" wd x 1 3/8" h o/a, 0.016" thk material; slide mts by 3 sides	Cover for A-615			CTT	152040	152040	A-616	1	-	-	-	-
SYMBOL DESIGNATION A-701 AND A-702 USED ON CY-870/UG CABINET ONLY													
A-701	MOUNT, vibration: round mtg; 30 to 84 lb load rating; approx 3" sq x 1 1/2" h o/a; rubber cushion mtg, formed metal plate 3" diam x 1" h; steel ctr sleeve w/3/8" diam bolt hole; 4 mtg holes 1/4" diam on 2 1/2" x 2 1/2" mtg/c	Vibration mount for CY-870/UG		# N17-M-75297-6751	CAYU	C-2035	151594	A-701	4	-	-	-	-
A-702	BRACKET: "U" shaped, both ends formed; steel, nickel plated; approx 2 3/8" sq x 1 1/16" h o/a, 0.090" thk material; mts by 4 body holes in corners of formed ends; body hole in bottom of "U"	Mounting for cradle assembly		# N17-T-350014-782	CTT	151584	151584	A-702	4	-	-	-	-
SYMBOL DESIGNATIONS A-751 TO A-758 INCL USED ON CY-870/UG AND CY-871/UG CABINETS													
A-751	COVER: black bakelite; approx 5 3/16" lg x 2 3/16" wd x 1/16" thk o/a; mts by two body holes	Shield for TB-751, TB-752 or TB-753		# N17-T-350014-758	CTT	151436	151436	A-751	3	-	-	-	-
A-753	MOUNT, vibration: round mtg; 30 to 72 lb load rating; approx 2 3/8" sq x 1 1/8" h o/a; rubber cushion mtg, formed metal plate 2 1/4" diam x 1 1/16" h; steel ctr sleeve w/1/4" diam bolt hole; 4 mtg holes 0.196" diam on 1 15/16" x 1 15/16" mtg/c	Rear vibration mount for CY-871/UG		# N17-M-75164-2706	CAYU	C-1035	151587	A-753	2	-	-	-	-
A-754	MOUNT, vibration: round mtg; 43 to 100 lb load rating; approx 2 3/8" sq x 1 1/8" h o/a; rubber cushion mtg, formed metal plate 2 1/4" diam x 1 1/16" h; steel ctr sleeve w/1/4" diam bolt hole; 4 mtg holes 0.196" diam on 1 15/16" x 1 15/16" mtg/c	Front vibration mount for CY-871/UG		# N17-M-75322-4551	CAYU	C-1050	151588	A-754	2	-	-	-	-

A-756	BRACKET: rectangular shape w/one side cut on angle from approx ctr; steel, nickel plated; approx 1 1/4" lg x 3/4" wd x 0.065" thk o/a; mts by body hole near angle and two elongated slots in other end	Mounts one end of O-762	# N17-T-350014-763	CTT	151516	151516	A-756	1	-	-	-	-
A-757	BRACKET: irregular shape; steel, nickel plated; approx 1 3/4" lg x 1 5/8" h x 1 1/2" wd o/a, 0.065" thk material; mts by 3 tapped holes in body; 3 tapped holes, 2 body holes, csk hole and cut out distributed on 3 irregular shaped formed arms	Mounts -756, O-767 and I-752	# N17-T-350014-777	CTT	151564	151564	A-757	1	-	-	-	-
A-758	BRACKET: switch support; "L" shape; steel, nickel plated; approx 2 11/16" lg x 1 5/16" wd x 1 5/16" h o/a, 0.048" thk material; mts by two body holes in one side; cutout on corner and large body hole one side	Mounts S-751 to cabinet dome	# N17-T-350014-899	CTT	151990	151990	A-758	1	-	-	-	-
A-1101	CONTAINER: aluminum, plain anodize finish; inverted table shape; approx 15 1/8" lg x 8 1/8" h x 4 5/8" wd o/a, 0.064" thk material; mts by hole ea end; four tapped holes, one body hole w/tooth and 11 irregular sized holes irregularly spaced on body	Mounts all parts of SB-154/UG	N17-T-350014-247	CTT	151420	151420	A-1101	1	-	-	-	-
A-1102	PLATE, clamp; steel, nickel plated; approx 9/16" lg x 3/8" h x 0.095 thk o/a; mts by tapped hole in ctr	Locks O-1102 to A-1101	N17-T-350013-733	CTT	151427	151427	A-1102, A-1103, A-1106	6	-	-	-	-
A-1103	Same as A-1102	Locks O-1103 to A-1101										
A-1104	FRAME: steel, nickel plated; "U" shaped, each side tapers near bridge, 1 side has 2 cutouts with slots, 7 body holes and 1 elongated hole, other side has 6 body holes, bridge has small slot each side and 1 elongated hole, insulator riveted inside 1 side; approx 4 1/4" h x 2 1/4" wd x 1 15/16" dp o/a, material 0.065" thk; mts by 2 bottom body holes ea side; stamp 1/8" characters "U. S. PATENT - 1964268"	Mounts misc parts of electrical motor control unit	N17-T-350013-722	CTT	151403	151403	A-1104	1	-	-	-	-
A-1105	BASE: steel, nickel plated; "U" shaped, bridge has 4 body holes, 2 tapped holes, 3 elongated holes and formed down ends, walled side has 2 tapped holes, other side has 2 cutout legs, both sides have upright ears; approx 4 13/16" wd x 2 11/16" dp x 2 3/8" h o/a, 0.065" thk material; mts by elongated hole on ea end	Mounts A-1104 and misc parts of electrical motor control unit to A-1101	N17-T-350013-720	CTT	151401	151401	A-1105	1	-	-	-	-
A-1106	Same as A-1102	Locks A-1105 to A-1101										
A-1107	COVER: black bakelite; approx 2 15/16" lg x 2 3/32" h x 2 17/32" wd o/a, 0.093" thk material; mts by 2 elongated cutouts; open on 2 sides	Cover for K-1101	N17-T-350014-856	CTT	151813	151813	A-1107	1	-	-	-	-
A-1108	BRACKET: relay support; straight shape, both ends formed; aluminum, plain anodized; approx 3 1/4" lg x 2 17/32" wd x 5/8" h o/a, 0.064" thk material; mts by 2 body holes in wider formed end; embossed w/tapped hole in 2 places on narrow formed end, 2 body holes and two embossed ribs on straight side	Mounts K-1101 to O-1101	N17-T-350014-857	CTT	151814	151814	A-1108	1	-	-	-	-
A-1302	FRAME: steel, nickel plated; irregular shape, "L" formed, 3 tapped holes and irregular shaped cutout one side, two tapped holes, mtg holes and irregular shaped cutout in other side; approx 3 1/4" lg x 1 5/32" h x 1 13/32" wd o/a, 0.065" thk material; mts by one elongated and two body holes one side; numerals "1, 2, 3" stamped on mtg side	Mounts printing carriage mechanism	N17-T-350014-128	CTT	150060	150060	A-1302	1	-	-	-	-

# A-701 and A-702 used on CY-870/UG only, A-751 to A-758 used on CY-870/UG and CY-871/UG

TABLE 8-4. COMBINED PARTS AND SPARE PARTS LIST

SYMBOL DESIG.	NAME OF PART AND DESCRIPTION	FUNCTION	JAN OR NAVY TYPE DESIGNATION	STANDARD NAVY STOCK NUMBER	MANUFACTURERS		TELETYPE PART NO.	ALL SYMBOL DESIGNATIONS INVOLVED	TOTAL NO. PER EQUIP.	SPARE PARTS			
					CODE	DESIG.				EQUIP.		STOCK	
										BOX	QUAN.	BOX	QUAN.
A-1303	BRACKET: code bar support; irregular shape w/9 slots 1 side, 4 slots other side and rounded ear; brass, nickel plated; approx 1 1/2" lg x 1 1/8" h x 1 3/8" wd o/a; mts by 2 tapped holes through body; 3 tapped and 2 body holes irregularly located on bracket	Guide for O-1332 through O-1339, O-1342 and O-1471 through O-1476		N17-T-350014-647	CTT	150372	150372	A-1303	1	-	-	-	-
A-1304	BRACKET: code bar support; irregular shape; brass, nickel plated approx 1 9/16" lg x 1 3/8" h x 1 9/16" wd o/a; mts by 2 tapped holes in base of "U" shaped side; 9 slots 1 side w/cutout across slots, 5 tapped holes and 1 body hole irregularly located	Guide for O-1332 through O-1339 and O-1342		N17-T-350014-234	CTT	150286	150286	A-1304	1	-	-	-	-
A-1305	BRACKET: steel, nickel plated; approx 1 7/16" lg x 15/16" wd x 7/16" thk o/a; 1 rd mtg hole and 1 elongated mtg hole; ctr of bracket cutout, 9 slots ea side of cutout, 9 holes in 2 rows also 2 tapped holes on ea side of brackets, stamped "SUP 4, 1, 5, 2, 3 COM, O, S," on top of bracket and "M.S." on end of bracket	Mounts O-1349 and O-1348		N17-T-350014-648	CTT	150373	150373	A-1305	1	-	-	-	-
A-1306	BRACKET: irregular shape; steel, nickel plated; approx 2 13/16" lg x 1 15/16" h x 1 1/2" wd o/a, 0.065" thk material; mts by two holes in line in formed arms; two formed mtg arms w/ear w/ck hole in ea, formed body arm w/short stud welded near end, lg stud welded to straight body arm, 2 body ears, 1 w/ck hole, 2 body holes and 1 tapped hole, R H mtg	Mounts part of left hand ribbon mechanism and pivots on shaft of A-1311 to feed ribbon to left		N17-T-350014-151	CTT	150313	150313	A-1306	1	-	-	-	-
A-1307	BRACKET: irregular shape; steel, nickel plated; approx 2 13/16" lg x 1 15/16" h x 1 1/2" wd o/a, 0.065" thk material; mts by 2 holes in line in formed arms; two formed mtg arms w/ear w/ck hole in ea, formed body arm w/short stud welded near end, lg stud welded to straight body arm, 2 body ears, 1 w/ck hole, 2 body holes and 1 tapped hole, L H mtg	Mounts part of right hand ribbon mechanism and pivots on H-1386 to feed ribbon to right		N17-T-350014-152	CTT	150312	150312	A-1307	1	-	-	-	-
A-1308	PLATE, adjusting: steel, nickel plated; rounded one end w/formed ear; approx 1 1/2" lg x 3/8" wd x 3/16" dp o/a, material 0.032" thk; mts by center body hole, elongated hole; body hole near rounded end	Holds O-1421 through O-1426 to A-1319		N17-T-350014-165	CTT	150294	150294	A-1308, A-1319	2	-	-	-	-
A-1309	BRACKET: irregular shape, formed at both ends; steel nickel plated; approx 1 3/16" lg x 3/4" h x 11/16" wd o/a, 0.065" thk material; mts by 2 elongated holes in wd end; elongated cutout in narrow end	Guide and stop for O-1351		N17-T-350014-258	CTT	150333	150333	A-1309, A-1310	2	-	-	-	-
A-1310	Same as A-1309	Guide and stop for O-1383											

A-1311	BRACKET: 3 irregular shaped extensions; steel, nickel plated; approx 2 1/16" lg x 1 5/8" h x 2" wd o/a, 0.065" thk material; mts by 2 body holes and elongated hole irregularly spaced; stud welded to one end, 2 tapped holes and 1 body hole irregularly spaced	Mounts part of left hand ribbon mechanism and pivot for A-1306	N17-T-350013-997	CTT	150317	150317	A-1311	1	-	-	-	-	-	-
A-1312	BRACKET: irregular shape w/four formed ears, one arm and 3 cutouts; steel, nickel plated; approx 3" lg x 2 1/2" h x 1" wd o/a, 0.050" thk material; mts by tapped hole in ea of 2 large ears and large body hole; 1 hole in largest ear, 3 body holes, 1 elongated slot and elongated cutout, R H mtg	Right side mounting bracket for function box mechanism	N17-T-350013-586	CTT	150580	150580	A-1312	1	-	-	-	-	-	-
A-1314	BRACKET: irregular shape w/four formed ears, 1 arm and 3 cutouts; steel, nickel plated; approx 3" lg x 2 1/2" h x 1" wd o/a, 0.050" thk material; mts by tapped hole in ea of two large ears and large body hole; one hole in largest ear, three body holes, one elongated slot and one elongated cutout, L H mtg	Left side mounting bracket for function box mechanism	N17-T-350013-583	CTT	150570	150570	A-1314	1	-	-	-	-	-	-
A-1315	PLATE, mounting: steel, nickel plated; approx 1/2" wd x 2 1/2" lg x 0.065" thk o/a; mts by 4 tapped holes, 1 elongated hole and 1 body hole	Mounts signal bell contact mechanism	N17-T-350014-194	CTT	150589	150589	A-1315	1	-	-	-	-	-	-
A-1316	TRACK: steel, nickel plated; body formed 1 side; approx 10 5/32" lg x 5/8" h x 1/4" wd o/a, 0.050" thk material; mts by hole and elongated slot in ears	Operates O-1322 and O-1324	N17-T-350013-589	CTT	150598	150598	A-1316	1	-	-	-	-	-	-
A-1319	Same as A-1308	Holds O-1421 through O-1426 to A-1308												
A-1320	PLATE: steel, nickel plated; "C" shape; approx 7/8" lg x 9/16" wd x 0.050" thk o/a; mts by 2 body holes	Support for E-1308	N17-T-350014-542	CTT	150483	150483	A-1320	1	-	-	-	-	-	-
A-1321	BRACKET: aluminum, plain anodized; approx 2 9/16" lg x 2 13/16" wd x 1 1/4" h o/a; mts by 2 body holes; 6 tapped holes in corner ears	Mounts magnet mechanism	N17-T-350013-982	CTT	150491	150491	A-1321	1	-	-	-	-	-	-
A-1322	BRACKET: irregular shape; steel, nickel, plated; approx 1 3/16" lg x 3/4" wd x 5/8" h o/a, 0.042" thk material; mts by 2 body holes in formed side; 2 formed ears, 1 w/ck hole other slotted at end	Spring mount and guide for O-1503	N17-T-350014-548	CTT	150490	150490	A-1322	1	-	-	-	-	-	-
A-1323	BRACKET: "C" shape; steel, nickel plated; approx 1 7/8" lg x 1 1/2" h x 5/8" wd o/a, 0.050" thk material; mts by 2 holes in body; 2 formed ears, 1 irregular shape w/cutout at end	Mounts O-1614 and anchor for O-1600 and O-1603	N17-T-350013-592	CTT	150675	150675	A-1323	1	-	-	-	-	-	-
A-1324	TRACK: steel, nickel plated; lg and narrow body w/curved ear at ea end; approx 11 1/4" lg x 1 7/8" h x 1/4" wd o/a, 0.067" thk material; mts by hole at end of ea ear and elongated slot above ea ear; one small and four large elongated slots, one small and two large body holes	Track for printing carriage mechanism	N17-T-350014-370	CTT	150844	150844	A-1324	1	-	-	-	-	-	-
A-1325	BRACKET: "L" shaped; steel, nickel plated; approx 5/8" lg x 1/2" h x 3/8" wd o/a, 0.065" thk material; mts by 2 tapped holes in wd end, L H mtg; narrow end formed w/notch on one side	Allows O-1646 to operate O-1534	N17-T-350013-959	CTT	150763	150763	A-1325	1	-	-	-	-	-	-

TABLE 8-4. COMBINED PARTS AND SPARE PARTS LIST

SYMBOL DESIG.	NAME OF PART AND DESCRIPTION	FUNCTION	JAN OR NAVY TYPE DESIGNATION	STANDARD NAVY STOCK NUMBER	MANUFACTURERS		TELETYPE PART NO.	ALL SYMBOL DESIGNATIONS INVOLVED	TOTAL NO. PER EQUIP.	SPARE PARTS			
					CODE	DESIG.				EQUIP.		STOCK	
										BOX	QUAN.	BOX	QUAN.
A-1326	BRACKET: "L" shape; steel, nickel plated; approx 5/8" lg x 1/2" h x 3/8" wd o/a, 0.065" thk material; mts by 2 tapped holes in wd end, R H mtg; narrow end formed w/notch on 1 side	Allows O-1646 to operate O-1550		N17-T-350013-960	CTT	150764	150764	A-1326	1	-	-	-	-
A-1327	PLATE, clamp: steel, nickel plated; irregular shaped w/elongated cutout and formed arm; approx 11/16" lg x 7/16" h x 7/16" wd o/a, 0.042" thk material; mts by 2 body holes	Clamps W-1303 to O-1672		N17-T-350014-218	CTT	150531	150531	A-1327	1	-	-	-	-
A-1328	COVER: steel, black oxide; flat curved shape, formed to hook shape ea end, 2 teeth on one side; approx 1 7/8" lg x 13/32" wd x 1/8" h o/a, 0.012" thk material; mts by hooked ends; figures "LTRS" and "FIGS" stamped below teeth	Indicates which side letters and figures are on and keeps dirt out of type box mechanism		N17-T-350013-760	CTT	151656	151656	A-1328	1	-	-	-	-
A-1329	TRACK: nickel chrome steel, black oxide finish; approx 13 3/8" lg x 3/4" h x 1/4" wd o/a; mts by 2 body holes one end and 2 elongated slots other end; 5 elongated slots, steel stiffener strip w/12 elongated ears, evenly spaced, welded by 4 end ears on rear of track between end slots and mtg holes	Guide for O-1848 through O-1849 and O-1912 and positions type box mechanism		N17-T-350014-294	CTT	150824	150824	A-1329	1	-	-	-	-
A-1330	HOUSING: steel, nickel plated; approx 1 1/2" OD x 3/4" ID x 5/8" thk o/a; mts by 4 tapped holes; dished out, cutout to ID, 2 slots in circum	Shield for O-1756		N17-T-350014-685	CTT	150442	150442	A-1330	1	-	-	-	-
A-1331	BRACKET: irregular shape; steel, nickel plate finish; approx 4 5/32" lg x 2 13/16" wd x 7/8" dp o/a; mts by 3 tapped holes in body; 1 side formed w/notched ear on side of elongated cutout, formed arm w/tapped hole, formed notched ear opposite formed side, 3 body holes	Pivot for O-2030 and O-2051 and mounts H-2023, O-2050 and O-2024		N17-T-350014-556	CTT	150789	150789	A-1331	1	-	-	-	-
A-1332	BRACKET: "U" shaped; steel, nickel plated; approx 1 1/2" lg x 7/8" h x 1" wd o/a, 0.065" thk material; mts by 2 tapped holes in bottom of "U"; 2 studs and spring post riveted on facing sides	Holds O-2034 and O-2035 to O-2025 and pivot for O-2033 and O-2043		N17-T-350014-202	CTT	150560	150560	A-1332	1	-	-	-	-
A-1333	BRACKET: "L" shape; steel, nickel plated; approx 1 3/8" lg x 7/8" h x 3/8" wd o/a, 0.065" thk material; mts by 2 body holes in curved end; rectangular shaped slot in squared end	Guide for O-2033		N17-T-350014-205	CTT	150557	150557	A-1333	1	-	-	-	-

## PARTS LISTS

## NAVSHIPS 91393

TT-47/UG, TT-48/UG, TT-69/UG, TT-70/UG

Section 8  
A-1334-B-601

A-1334	BRACKET: irregular shape; steel, nickel plated, approx 9 1/4" lg x 2 1/4" h x 1/2" wd o/a, 0.035" thk material; mts by body hole in short ear and elongated slot in lg ear; body slants down 1 end and curves up on other end, formed arm on ea side w/formed mtg ear at end of ear arm	Guides paper to O-2075	N17-T-350014-368	CTT	150840	150840	A-1334	1	-	-	-	-	-
A-1335	BRACKET: "L" shape; steel, nickel plated; approx 7/8" lg x 7/16" h x 9/16" wd o/a, 0.065" thk material; mts by elongated hole and body hole in lg end; tapped hole in short end	Mounts A-1334 and O-2070 to right side frame	N17-T-350014-290	CTT	150817	150817	A-1335, A-1336	2	-	-	-	-	-
A-1336	Same as A-1335	Mounts A-1334 and O-2070 to left side frame											
A-1337	BRACKET: "L" shape; steel, nickel plated; approx 7/8" lg x 11/16" wd x 5/8" h o/a, 0.095" thk material, mts by 2 tapped holes in curved end and 1 tapped hole in squared end, R H mtg	Mounts A-1312 to right side frame	N17-T-350014-210	CTT	150545	150545	A-1337	1	-	-	-	-	-
A-1338	BRACKET: elongated cutout 1 side w/body ear in ctr and formed ear ea side of cutout; steel, nickel plated; approx 1 1/16" lg x 5/16" h x 1/4" wd o/a, 0.035" thk material; mts by body hole in ea formed ear; numerals "1" and "2" stamped on front of bracket	Positioning detent for O-2087	N17-T-350014-331	CTT	150917	150917	A-1338	1	-	-	-	-	-
A-1339	BRACKET: "L" shaped; steel, nickel plated; approx 7/8" lg x 11/16" wd x 5/8" h o/a; 0.095" thk material; mts by 2 tapped holes in curved end and 1 tapped hole in squared end; L H mtg	Mounts A-1314 to left side frame	N17-T-350014-209	CTT	150546	150546	A-1339	1	-	-	-	-	-
A-1340	BRACKET: irregular shape w/two formed arms; steel, nickel plated; approx 7/8" lg x 7/8" h x 1/2" wd o/a, 0.050" thk material; mts by 2 body holes	Back stop for O-2109 to O-2113	N17-T-350014-702	CTT	150475	150475	A-1340	1	-	-	-	-	-
A-1341	BRACKET: "U" shape; steel, nickel plated; approx 7/8" h x 1" lg x 7/8" wd o/a, 0.065" thk material; mts by 3 body slots; elongated cutout on both legs	Guide for O-2092 and O-2101	N17-T-350014-240	CTT	151670	151670	A-1341	1	-	-	-	-	-
B-501	FAN: turbine type; electric motor operated; aluminum blades; approx 3 1/8" OD x 3/8" ID x 2 1/32" wd o/a; direct drive; mts by body hole through hub	Cools PD-17A/U		CTT	123769	123769	B-501	1	-	-	-	-	-
B-601	FAN: 16 fins equally spaced on circum, threaded shank in ctr 1 side, insulator, shield, insulator, collector ring, insulator, collector ring, insulating washer and nut mtd on threaded shank, other side irregularly dished out w/slot through OD and 3 oval shaped elongated rises in cutout, shank in ctr cut flat 1 side w/collector ring wires extending through fan on 2 sides, slot around circum; approx 1 1/2" lg x 3 1/2" OD x 3/8" ID o/a; mts by ID; two tapped holes in ea rise, 1 tapped hole and body hole through shank on flat side	Mounts governor mechanism and cools PD-18/U	N17-T-350014-304	CTT	150997	150997	B-601	1	-	-	-	-	-

CHANGE 1

8-13

TABLE 8-4. COMBINED PARTS AND SPARE PARTS LIST

SYMBOL DESIG.	NAME OF PART AND DESCRIPTION	FUNCTION	JAN OR NAVY TYPE DESIGNATION	STANDARD NAVY STOCK NUMBER	MANUFAC- TURERS		TELETYPE PART NO.	ALL SYMBOL DESIGNATIONS INVOLVED	TOTAL NO. PER EQUIP.	SPARE PARTS			
					CODE	DESIG.				EQUIP.		STOCK	
										BOX	QUAN.	BOX	QUAN.
C-501	CAPACITOR, fixed: electrolytic; 43 to 48 mfd; 110 v ac; approx 3 1/4" lg x 1 1/8" diam o/a; tubular cardboard case; two solder lug terminals	Starting capacitor for PD-17/U or PD-17A/U		N16-C-19925-1001	CG	111A-209AA-G1	122245	C-501	1	-	-	-	-
C-601	CAPACITOR, fixed: mica; 800 mmf; 500 vdcw; approx 5/8" diam x 1 1/16" lg, less terminals; bakelite; 2 wire lead term; spring on end of 1 term	Suppresses electrical noise by connecting to holder of E-607		N17-T-350013-806	CTT	122233	122233	C-601, C-603	2	-	-	-	-
C-602	CAPACITOR, fixed: paper dielectric w/aluminum foil; one section; .5 mfd ±20%; 1000 vdcw; metal casing, hermetically sealed; approx 2 1/4" h x 1 5/16" lg x 5/8" wd; mineral oil impregnated; 2 solder lugs located at top; clamp not included	Spark suppressor for R-601 and R-602		N16-C-47329-8532	CTD	OM-105C	150979	C-602	1	-	-	-	-
C-603	Same as C-601	Suppresses electrical noise by connecting to holder of E-608											
E-101	INSULATOR, plate: rectangular shape w/curved ends; natural color bakelite; approx 2 1/4" lg x 1" wd x 1/16" thk o/a; mts by 2 holes; figures "1, 2, 3, 4" stamped once across top and bottom	Insulators for TB-101		N17-T-350014-353	CTT	150966	150966	E-101, E-1109	3	-	-	-	-
E-102	INSULATOR, plate: irregular shape; gray fibre; approx 1 7/8" lg o/a; approx 5/8" wd x 1/2" h o/a, 0.016" thk, mts by 2 body holes 1 9/16" mtg/c; ctr of 1 side cutout and formed down	Insulates connecting pins of J-101 from H-130		N17-T-350014-860	CTT	151809	151809	E-102, E-1306	4	-	-	-	-
E-103	CONTACT, box: iron, nickel plated; approx 1 3/4" lg x 1 5/16" wd x 5/8" h o/a, 0.025" thk material; mts by 2 body holes; 2 body holes 1 side, 2 body holes in bottom	Container for contact mechanism		N17-T-350013-714	CTT	151358	151358	E-103	1	-	-	-	-
E-104	INSULATOR, bushing: cylindrical shape; black bakelite; Grade XX; 5/32" lg o/a; approx 1/4" OD x 3/32" ID, body 3/16" diam	Insulates O-225 from O-307		N17-T-350014-477	CTT	151183	151183	E-104	1	1	1	-	-
E-105	TERMINAL, lug: nickel silver; approx 7/32" wd x 3/8" lg x 1/8" h o/a, 0.015" thk material; solder connects to wire; rounded end w/concentric hole, other end curved w/formed arm in cutout	Terminal for W-102		N17-T-350014-480	CTT	151179	151179	E-105	2	-	-	-	-
E-106	SCREW, contact: wrench drive; Hex head; steel, nickel plated; #4-40; approx 7/16" lg o/a; 3/16" lg threaded portion; head 5/32" thk x 1/4" across flats; approx 1/8" diam x 1/32" thk tungsten point braced on Hex head	Contacts for O-225		N17-T-350014-484	CTT	151173	151173	E-106	2	1	2	-	-

8-14

CHANGE 1

CHANGE 1

E-107	TERMINAL, lug; nickel silver; approx 1 1/16" lg x 5/16" h x 3/16" wd o/a, 0.032" thk material; solder connects to wire; "V" shaped cutout 1 side, formed ear (tinned dipped) and rectangular cutout other side, small arm same side	Terminal for W-102	N17-T-350014-482	CTT	151177	151177	E-107	1	1	1	-	-
E-108	TERMINAL: nickel silver; narrow end formed to "U" shape, body hole in other end; approx 5/8" lg x 1/4" wd x 1/8" h o/a, 0.015" thk material; formed end tin dipped	Holds cable from Z-101 to keyboard base		CTT	151365	151365	E-108	1	-	-	-	-
E-501	MOTOR, motor: c/o shaft w/armature in ctr, bladed shield, pull washer and ball bearing on ea side of armature; steel w/copper bars; 115 v, 2 amp; 1/20 hp, 3600 rpm; approx 9 5/8" lg x 2" diam o/a; bearing shoulders diam approx 1/2", bearing ctrs approx 4 1/4" apart; tapped hole near ea end of shaft	Operates A-502 and O-507, or O-508	N17-T-350014-715	CG	111B-102AA-G1	122255	E-501	1	-	-	-	-
E-502	INSULATOR, plate: rectangular w/both corners cutout on one side; PS grade, natural color bakelite; approx 2 9/16" lg o/a; 1 3/8" wd x 1/32" thk o/a, two 1/8" diam mtg holes 2 9/32" c to c	Insulator for K-501		CTT	151924	151924	E-502	1	-	-	-	-
E-503	WASHER, flat: natural color bakelite, P S grade; round, approx 9/32" OD x 1/8" ID x 0.031" thk o/a	Insulating washer for S-501		CTT	87334	87334	E-503	4	-	-	-	-
E-601	BRUSH, electrical contact: carbon, Natl. Carbon Grade "AY"; rectangular shape, approx 3/4" lg x 5/16" wd x 1/8" thk, shunt 1 1/4" lg; mts by hole in terminal plate soldered to shunt; concave contact; round groove opposite contact end	Connects W-601 and motor connector with E-606	N17-T-350014-314	CTT	150882	150882	E-601, E-602	2	-	-	-	-
E-602	Same as E-601	Connects W-601 motor connector with E-617										
E-603	INSULATOR, plate: oblong shape; natural color bakelite; approx 1 1/4" lg x 11/16" wd x 1/32" thk o/a; mts by 2 holes	Insulates A-602 from B-601	N17-T-350014-372	CTT	150850	150850	E-603, E-604, E-605	3	-	-	-	-
E-604	Same as E-603	Insulates A-604 from B-601										
E-605	Same as E-603	Insulates A-603 from B-601										
E-606	CONTACT, governor: irregular shaped and formed arm riveted to flat spring and plate, tungsten point on end of arm; approx 2" lg x 7/16" h x 1/4" wd o/a; mts by hole in spring; hole in approx ctr of arm	Opens and closes resistance circuit for PD-18/U	N17-T-350014-374	CTT	150856	150856	E-606	1	1	1	-	-
E-607	BRUSH, electrical contact; carbon brush; rectangular shape, approx 11/16" lg x 3/8" wd x 1/8" thk o/a, 1 3/4" lg spring w/term at end, pigtail connects from brush to term; mts by term; commutator end concave	Completes series circuit, connects O-615 to E-609	N17-B-86234-3601	CG	5899-506AEL	122205	E-607, E-608	2	1	2	-	-
E-608	Same as E-607	Completes series circuit, connects O-615 to E-609										
E-609	ARMATURE, motor: c/o shaft w/armature in approx ctr, pull washer and ball bearing on ea side of armature; steel w/copper wire; 115 v, 2 amp; 1/20 HP, 3600 rpm; approx 9" lg x 2 1/4" diam o/a; approx diam of bearing shoulders 3/4" and 1/2", bearing ctrs 4 7/8" apart; motor number stamped on armature; tapped hole through shaft near ea end	Operates B-601 and O-507 or O-508	N17-T-350014-914	CG	SPAGGH Y1A	122210	E-609	1	-	-	-	-

PARTS LISTS

TT-47/UG, TT-48/UG, TT-69/UG, TT-70/UG

NAVSHIPS 91393

Section 8  
E-107-E-609

8-15



TABLE 8-4. COMBINED PARTS AND SPARE PARTS LIST

SYMBOL DESIG.	NAME OF PART AND DESCRIPTION	FUNCTION	JAN OR NAVY TYPE DESIGNATION	STANDARD NAVY STOCK NUMBER	MANUFACTURERS		TELETYPE PART NO.	ALL SYMBOL DESIGNATIONS INVOLVED	TOTAL NO. PER EQUIP.	SPARE PARTS			
					CODE	DESIG.				EQUIP.		STOCK	
										BOX	QUAN.	BOX	QUAN.
E-610	INSULATOR, bushing: round shape; natural color, Grade XX bakelite; approx 1/8" lg o/a; 7/32" OD x 1/8" ID o/a	Insulates A-602 from H-631		N17-T-350013-890	CTT	150868	150868	E-610, E-611, E-612	6	-	-	-	-
E-611	Same as E-610	Insulates A-603 from H-637 and H-638											
E-612	Same as E-610	Insulates A-604 from H-651 and H-652											
E-614	WASHER, flat: natural color bakelite; round, approx 1/2" OD x 1/4" ID x 1/32" thk o/a	Insulates A-602 from H-629		N17-T-350014-371	CTT	150849	150849	E-614, E-615, E-616	6	-	-	-	-
E-615	Same as E-614	Insulates A-603 from H-640											
E-616	Same as E-614	Insulates A-604 from H-654											
E-617	SCREW, contact: wrench drive; steel, nickel plated; #6-32; approx 3/8" lg o/a; 3/16" lg threaded portion; head 3/32" thk x 1/4" across flats; 1/4" diam x 1/16" thk contact brazed on head	Contact for resistance circuit for PD-18/U		N17-T-350012-623	CTT	6320	6320	E-617	1	1	1	-	-
E-618	INSULATOR, plate: rectangular shape; mica; 2 1/8" lg o/a; 1 3/8" wd x 1/32" thk	Insulates C-602 from R-603			CTT	152058	152058	E-618	1	-	-	-	-
SYMBOL DESIGNATIONS E-751 TO E-757 INCL USED ON CY-870/UG AND CY-871/UG CABINETS													
E-751	LAMP, incandescent: 6-8 v, 1.14 amps, 6 CP; bulb G-6, clear; 1 7/16" lg o/a; miniature bayonet base; C-2R filament; burn any position	Illuminates copy		# N17-L-5280	CG	82	151982	E-751, E-752, I-751	3	1	6	-	-
E-752	Same as E-751	Illuminates copy											
E-754	INSULATOR, plate: rectangular shape; grade P, natural color bakelite; approx 16" lg x 2 7/16" h x 0.016" thk o/a; mts by 6 holes irregularly spaced in row; white figures "1" through "30" stamped or stenciled across length	Insulates TB-751, TB-752 and TB-753 from cabinet shell		# N17-T-350014-757	CTT	151435	151435	E-754	1	-	-	-	-
E-755	ARMATURE ASSEMBLY: steel, nickel plated; "L" shape, c/o striker ball riveted to clapper which is welded to arm, plate welded to other end of arm; approx 1/2" wd x 1 3/4" lg x 1 9/16" h o/a; mts by 2 holes 1 end; arm formed at 1 end, 2 rectangular cutouts on arm	Rings I-752		# N17-T-350014-779	CTT	151567	151567	E-755	1	-	-	-	-

E-756	MAGNET: 190 ohms $\pm 10\%$ , #34 wire, 4,000 turns, 500 vact; approx 1 1/2" lg x 1" wd x 1 1/16" h o/a; mts by tapped hole in bottom	Attracts E-755	# N17-T-350013-603	CTT	247M	247M	E-756, E-1103	2	-	-	-	-
E-757	KNOB: "pear" shaped; grey bakelite; for 1/4" diam shaft; two #8-32 slotted type set screws; approx 1 5/8" lg x 19/32" h x 3/4" wd o/a; brass insert	Operates O-770	# N17-T-350014-851	H. DAVIS MOLDING CO. #2110		151556	E-757	1	1	1	-	-
E-1101	INSULATOR, plate: rectangular w/curved ends; natural color bakelite; approx 4 1/16" lg x 1" wd x 1/16" thk o/a; mts by hole near ea end; characters "1, 2, 3, 4, 5, 6, 7, 8, 9" stamped ea side equally spaced	Insulates TB-1101 from A-1101	N17-T-350013-727	CTT	151412	151412	E-1101, E-1106	2	-	-	-	-
E-1102	STRAP, terminal: nickel silver; 3 elongated cutouts forming 4 rounded ears; approx 1 3/8" lg x 9/16" h x 0.020" thk o/a; mts by 4 body holes in rounded ears	Connects H-1134 terminals	N17-T-350013-736	CTT	151438	151438	E-1102	2	-	-	-	-
E-1103	Same as E-756	Attracts E-1105 to S-1105										
E-1104	INSULATOR, plate: rectangular; natural color bakelite; approx 2 1/4" lg x 3/4" wd x 0.016" thk o/a; mts by hole ea end	Insulates S-1104 from A-1104	N17-T-350013-723	CTT	151406	151406	E-1104	1	-	-	-	-
E-1105	ARMATURE: steel w/2 bakelite insulators; c/o lg strip irregularly cutout 1 end w/elongated slot, formed in approx ctr, insulator riveted on ea side between irregular end and forming, armature riveted to other end; approx 2 5/8" lg x 1" h x 1/8" wd o/a; mts by slotted ear on ea corner of wd end and 2 body holes near ctr	Operates S-1104 and S-1105	N17-T-350013-734	CTT	151432	151432	E-1105	1	-	-	-	-
E-1106	Same as E-1101	Insulates TB-1102 from A-1105										
E-1107	ARMATURE: Norway iron, nickel plated; irregular shaped, w/2 rounded ends, 2 irregular shaped arms w/cutout between, 1 side, arm w/cutout other side, 2 brass rivets swaged near ea end of body; approx 1 11/16" h x 1 3/4" lg x 0.049" thk o/a; mts by irregular shaped arms; body hole near body cutout	Operates E-1105	N17-T-350013-763	CTT	151409	151409	E-1107	1	-	-	-	-
E-1108A	MAGNET: 132 ohms resistance, 500 v ac breakdown test; approx 1 1/2" lg x 1 1/4" h x 1 1/16" wd o/a; mts by ID through length	Attracts E-1107	N17-T-350013-605	CTT	246M	246M	E-1108A, E-1108B	2	-	-	-	-
E-1108B	Same as E-1108A	Attracts E-1107										
E-1109	Same as E-101	Insulates TB-1101 from TB-1103										
E-1301	SPRING, contact: nickel silver; one end formed w/notch on ea side, other end has irregular shaped bakelite fitting; approx 2" lg x 3/16" h x 3/8" wd o/a, 0.015" thk material; mts by round cutout near formed end; contact point riveted and soldered near bakelite fitting	Mates with E-1302 and operates signal bell	N17-T-350013-588	CTT	150588	150588	E-1301	1	-	-	-	-

# E-751 to E-757 used on CY-870/UG and CY-871/UG

8-18

TABLE 8-4. COMBINED PARTS AND SPARE PARTS LIST

SYMBOL DESIG.	NAME OF PART AND DESCRIPTION	FUNCTION	JAN OR NAVY TYPE DESIGNATION	STANDARD NAVY STOCK NUMBER	MANUFAC- TURERS		TELETYPE PART NO.	ALL SYMBOL DESIGNATIONS INVOLVED	TOTAL NO. PER EQUIP.	SPARE PARTS			
					CODE	DESIG.				EQUIP.		STOCK	
										BOX	QUAN.	BOX	QUAN.
E-1302	SPRING, contact: nickel silver; one end formed w/two notches; approx 1 5/8" lg x 3/16" h x 1/8" wd o/a, 0.032" thk material; mts by round cutout near formed end; contact point riveted and soldered near straight end	Mates with E-1301 and operates signal bell		N17-T-350013-584	CTT	150576	150576	E-1302	1	1	1	-	-
E-1303	INSULATOR, bushing: tubular shape; natural color, grade XX bakelite; approx 1/4" lg o/a; 3/16" OD x 1/8" ID	Insulates E-1301 and E-1302 from H-1425		N17-T-350013-921	CTT	150553	150553	E-1303	1	-	-	-	-
E-1304	MAGNET: 132 ohms resistance, 500 v ac break-down test; approx 1 9/16" lg x 1 1/4" h x 7/8" wd o/a; mts by hole through length; screw mtg terminals	Attracts E-1308		N17-T-350013-604	CTT	245M	245M	E-1304, E-1305	2	1	1	-	-
E-1305	Same as E-1304	Attracts E-1308											
E-1306	Same as E-102	Insulates connecting pins of J-1301 from H-1452											
E-1308	ARMATURE: c/o arm extension w/formed sides, spring, clamp plate, arm w/formed ear, riveted together; approx 1 7/8" lg x 1/4" h x 7/8" wd o/a; mts by 2 holes in spring; slot in arm extension, csk hole in formed ear	Permits O-1500 to lock in unattracted position or O-1503 to lock in attracted position		N17-T-350014-225	CTT	150518	150518	E-1308	1	1	1	-	-
F-1101	FUSE, cartridge: 10 amp, 135% load for one hour; 125 volts or less; one time; ceramic body; ferrule terminals; nonindicating; approx 1 1/4" lg x 1/4" diam o/a	Protects one side of power circuit		N17-E-14327-30	GFA	ABC	151418	F-1101, F-1102	2	1	4	-	-
F-1102	Same as F-1101	Protects one side of power circuit											
H-101	SCREW, machine: slot drive; fil H; steel, nickel plated; #4-40; approx 9/16" lg o/a; 1/2" lg threaded portion; head 1/16" thk x 3/16" diam	Holds O-101 to A-101		N17-T-350014-116	CTT	150089	150089	H-101, H-102, H-103, H-177, H-1440, H-1446, H-1449, H-1583, H-1780, H-1801, H-1813	18	1	5	-	-
H-102	Same as H-101	Holds O-105 to A-101											
H-103	Same as H-101	Holds O-108 to A-101											
H-104	WASHER, flat: steel, nickel plated; round, approx 1/8" ID x 1/4" OD x 1/32" thk	Holds O-101 to A-101		N17-T-350012-634	CTT	125011	125011	H-104, H-107, H-110, H-154, H-161, H-167, H-238, H-394, H-532, H-1311, H-1407, H-1439, H-1442, H-1457, H-1472, H-1522, H-1605, H-1648, H-1651, H-1693, H-1849, H-1859, H-1862, H-1880, H-1945, H-1991, H-2006, H-2060, H-2064, H-2123, H-2168	45	1	10	-	-

CHANGE 1

8 Section  
E-1302-H-104

TT-47/UG, TT-48/UG, TT-69/UG, TT-70/UG

NAVSHIPS 91393

PARTS LISTS

## PARTS LISTS

## NAVSHIPS 91393

TT-47/UG, TT-48/UG, TT-69/UG, TT-70/UG

Section 8  
H-105-H-118

H-105	WASHER, lock: steel; round, approx 1/4" OD x 1/8" ID x 0.016" thk o/a; shakeproof type, straight internal teeth	Holds O-101 to A-101	N43-W-6806-5540	CTT	90951	90951	H-105, H-108, H-111, H-114	4	1	2	-	-
H-106	NUT, hexagon: steel, nickel plated; #4-40; 3/32" thk o/a; approx 3/16" across flats	Holds O-101 to A-101	N17-T-350012-486	CTT	3599	3599	H-106, H-109, H-112, H-115, H-149, H-156, H-158, H-169, H-210, H-222, H-233, H-235, H-244, H-266, H-320, H-386, H-390, H-1313, H-1315, H-1370, H-1376, H-1405, H-1507, H-1511, H-1547, H-1549, H-1551, H-1592, H-1741, H-1758, H-2084, H-2086	49	1	10	-	-
H-107	Same as H-104	Holds O-105 to A-101										
H-108	Same as H-105	Holds O-105 to A-101										
H-109	Same as H-106	Holds O-105 to A-101										
H-110	Same as H-104	Holds O-108 to A-101										
H-111	Same as H-105	Holds O-108 to A-101										
H-112	Same as H-106	Holds O-108 to A-101										
H-113	SCREW, machine: slot drive; FH; steel, nickel plated; #4-40; approx 11/16" lg o/a; threaded portion 5/8" lg; head 3/16" diam x 1/16" thk	Holds O-113 to A-101	N17-T-350014-890	CTT	151688	151688	H-113, H-175, H-1816	4	1	3	-	-
H-114	Same as H-105	Holds O-113 to A-101										
H-115	Same as H-106	Holds O-113 to A-101										
H-116	SCREW, pilot: wrench drive; Hex H; steel, nickel plated; #6-40; approx 27/32" lg o/a; 5/16" lg threaded portion incl slot; head 3/32" thk x 3/16" across flats; 7/16" lg x 3/32" diam pilot	Stop for O-120		CTT	95499	95499	H-116	1	1	1	-	-
H-117	WASHER, flat: steel, nickel plated; round, approx 1/8" ID x 1/4" OD x 1/32" thk o/a	Holds O-116 to A-101	N17-T-350006-300	CTT	8330	8330	H-117, H-1706, H-1707, H-1710, H-1723, H-1732, H-1744, H-1751, H-2129	10	1	4	-	-
H-118	WASHER, lock: steel; round, approx 1/4" OD x 5/32" ID x 1/32" thk o/a; split-ring type	Holds O-116 to A-101	N17-T-350005-561	CTT	2191	2191	H-118, H-122, H-124, H-127, H-133, H-135, H-139, H-144, H-163, H-165, H-183, H-186, H-198, H-203, H-212, H-217, H-219, H-240, H-249, H-252, H-269, H-271, H-279, H-288, H-299, H-306, H-364, H-504, H-507, H-510, H-517, H-519, H-524, H-541, H-602, H-604, H-607, H-609, H-612, H-615, H-617, H-619, H-621, H-624, H-626, H-630	354	1	35	-	-

CHANGE 1

8-19



H-119	NUT, hexagon: steel, nickel plated; #6-40; 3/32" thk o/a; approx 1/4" across flats	Holds O-116 to A-101	N17-T-350012-485	CTT	3598	3598	H-2015, H-2017, H-2025, H-2027, H-2029, H-2031, H-2035, H-2039, H-2043, H-2052, H-2055, H-2066, H-2070, H-2072, H-2074, H-2076, H-2078, H-2088, H-2092, H-2098, H-2101, H-2106, H-2125, H-2128, H-2133, H-2135, H-2138, H-2140, H-2142, H-2144, H-2146, H-2149, H-2151, H-2153, H-2155, H-2160, H-2162, H-2163, H-2167	76	1	20	-	-
H-120	SCREW, machine: slot drive; Fil H; steel, nickel plated; #2-56; approx 1/2" lg o/a; 7/16" lg threaded portion; head 1/16" thk x 1/8" diam	Holds S-101 to A-101	N17-T-350005-535	CTT	1178	1178	H-119, H-134, H-180, H-242, H-267, H-270, H-280, H-289, H-770, H-808, H-812, H-1123, H-1159, H-1161, H-1314, H-1318, H-1323, H-1474, H-1483, H-1494, H-1502, H-1530, H-1536, H-1538, H-1541, H-1557, H-1567, H-1606, H-1608, H-1621, H-1623, H-1636, H-1661, H-1669, H-1738, H-1746, H-1767, H-1834, H-1866, H-1870, H-1873, H-1884, H-1894, H-1909, H-1914, H-1921, H-1952, H-1962, H-1970, H-1973, H-1976, H-1987, H-1997, H-2013, H-2028, H-2029, H-2045, H-2053, H-2102, H-2126, H-2141, H-2156, H-2164	2	1	1	-	-
H-121	SCREW, machine: slot drive; FH; steel, nickel plated; #6-40; approx 5/16" lg o/a; 1/4" lg threaded portion; head 1/16" thk x 7/32" diam	Holds A-101 to keyboard base	N17-T-350014-590	CTT	151657	151657	H-121, H-123, H-138, H-164, H-184, H-248, H-253, H-523, H-601, H-618, H-1101, H-1102, H-1120, H-1126, H-1139, H-1360, H-1362, H-1413, H-1422, H-1477, H-1489, H-1527, H-1598, H-1628, H-1629, H-1638, H-1644, H-1676, H-1678, H-1681, H-1685, H-1899, H-1926, H-1930, H-1964, H-2009, H-2024, H-2026, H-2030, H-2038, H-2054, H-2065, H-2087, H-2096, H-2100, H-2105, H-2134, H-2137, H-2150	81	1	15	-	-
H-122	Same as H-118	Holds A-101 to keyboard base										
H-123	Same as H-121	Holds O-119 to keyboard base										

CHANGE 1

8-21

TABLE 8-4. COMBINED PARTS AND SPARE PARTS LIST

SYMBOL DESIG.	NAME OF PART AND DESCRIPTION	FUNCTION	JAN OR NAVY TYPE DESIGNATION	PARTS			ALL SYMBOL DESIGNATIONS INVOLVED	TOTAL NO. PER EQUIP.	SPARE PARTS						
				STANDARD NAVY STOCK NUMBER	MANUFAC- TURERS				TELETYPE PART NO.	EQUIP.		STOCK			
					CTT CODE	DESIG.				BOX	QUAN.	BOX	QUAN.		
H-124	Same as H-118	Holds O-119 to keyboard base													
H-125	WASHER, flat: steel, nickel plated; round, approx 5/16" OD x 5/32" ID x 0.028" thk o/a	Holds O-119 to keyboard base		N17-T-350005-776	CTT	7002	7002	H-125, H-250, H-505, H-508, H-542, H-605, H-610, H-613, H-622, H-629, H-640, H-644, H-648, H-654, H-807, H-816, H-1114, H-1118, H-1137, H-1152, H-1158, H-1169, H-1185, H-1186, H-1305, H-1445, H-1491, H-1529, H-1560, H-1581, H-1615, H-1627, H-1643, H-1680, H-1683, H-1698, H-1715, H-1718, H-1736, H-1748, H-1793, H-1890, H-1892, H-1995, H-2003, H-2036, H-2097, H-2136	71	1	20	-	-		
H-126	SCREW, machine: slot drive; FH; steel, nickel plated; #6-40; approx 7/16" lg o/a; 3/8" lg threaded portion, head 1/16" thk x 7/32" diam	Holds O-122 and H-129 to keyboard base		N17-T-350013-709	CTT	151346	151346	H-126, H-185, H-229, H-362, H-518, H-670, H-1388, H-1702, H-1704, H-1708, H-1804, H-1938, H-1940, H-1948, H-1950	28	1	10	-	-		
H-127	Same as H-118	Holds O-122 and H-129 to keyboard base													
H-128	STUD: steel, nickel plate; approx 7/8" lg x 5/16" OD o/a; shank end thd #6-40 3/16" lg; body has 1/8" diam hole, front end tapers to 3/32" diam	Guide for right or left side frame		N17-T-350014-461	CTT	151116	151116	H-128	2	-	-	-	-		
H-129	STRAP, mounting: steel, nickel plated; approx 1 3/16" lg x 5/8" wd x 1/8" thk o/a; mts by 1 large and 1 small tapped hole, 1 end curved	Locks H-297		N17-T-350014-472	CTT	151146	151146	H-129, H-364	6	-	-	-	-		
H-131	CLAMP: connector plug; steel, nickel plated; 1 screw, lock washer and washer employed; adjustable from approx 3 5/16" lg to 3 7/8" lg x 1 7/8" wd x 1 5/8" h o/a	Clamps P-1102 to J-101		N17-T-350014-855	CTT	151811	151811	H-131	1	-	-	-	-		
H-132	SCREW, machine: slot drive; FH; steel, nickel plated; #6-40; approx 1/4" lg o/a; 3/16" lg threaded portion; head 1/16" thk x 7/32" diam	Holds H-131 to keyboard base		N17-T-350014-594	CTT	151692	151692	H-132, H-143, H-162, H-197, H-202, H-211, H-216, H-218, H-239, H-254, H-298, H-540, H-1303, H-1383, H-1416, H-1418, H-1430, H-1431, H-1433, H-1453, H-1577, H-1579, H-1655, H-1660, H-1672, H-2042, H-2075, H-2077	49	1	4	-	-		

8-22

CHANGE 1





TABLE 8-4. COMBINED PARTS AND SPARE PARTS LIST

SYMBOL DESIG.	NAME OF PART AND DESCRIPTION	FUNCTION	JAN OR NAVY TYPE DESIGNATION	STANDARD NAVY STOCK NUMBER	MANUFAC- TURERS		TELETYPE PART NO.	ALL SYMBOL DESIGNATIONS INVOLVED	TOTAL NO. PER EQUIP.	SPARE PARTS			
					CODE	DESIG.				EQUIP.		STOCK	
										BOX	QUAN.	BOX	QUAN.
H-148	SCREW, shoulder: slot drive; FH; steel, nickel plated; #4-40; approx 1/2" lg o/a; 5/32" lg threaded portion incl neck; head 1/16" thk x 1/4" diam; shoulder 5/16" lg x 5/32" diam	Holds O-124 to A-103		N17-T-350013-792	CTT	102057	102057	H-148	1	1	1	-	-
H-149	Same as H-106	Holds O-124 to A-103											
H-150	SCREW, machine: slot drive; Fil H; steel, nickel plated; #2-56; approx 7/16" lg o/a; 3/8" lg threaded portion; head 1/16" thk x 3/16" diam	Holds S-102 to A-103		N17-T-350013-359	CTT	125181	125181	H-150	2	1	1	-	-
H-151	SCREW, machine: slot drive; FH; steel, nickel plated; #4-40; approx 5/16" lg o/a; 1/4" lg threaded portion; head 1/16" thk x 3/16" diam	Holds A-104 to O-129		N17-T-350013-756	CTT	151637	151637	H-151, H-236, H-246, H-534, H-536, H-538, H-1343, H-1353, H-1389, H-1395, H-1427, H-1603, H-1691, H-1740, H-1757, H-1851, H-1942, H-1989	33	1	7	-	-
H-152	Same as H-47	Holds A-104 to O-129											
H-153	SCREW, shoulder: slot drive; FH; steel, nickel plated; #4-40; approx 3/8" lg o/a; 1/4" lg threaded portion; head 1/16" lg x 1/4" diam; shoulder 1/16" lg x 5/32" diam; slot between shoulder and threaded portion	Holds O-126 to A-104		N17-T-350013-710	CTT	151350	151350	H-153, H-1448	2	1	1	-	-
H-154	Same as H-104	Holds O-126 to A-104											
H-155	Same as H-147	Holds O-126 to A-104											
H-156	Same as H-106	Holds O-126 to A-104											
H-157	SCREW, shoulder: slot drive; FH; steel, nickel plated; #4-40; approx 1/4" lg o/a; 7/64" lg threaded portion; head 1/16" thk x 7/32" diam; shoulder 1/16" lg x 5/32" diam; slot between shoulder and threaded portion	Holds O-128 to O-126		N17-T-350014-407	CTT	151036	151036	H-157, H-232, H-234	3	1	1	-	-

8-24

CHANGE 1



TABLE 8-4. COMBINED PARTS AND SPARE PARTS LIST

SYMBOL DESIG.	NAME OF PART AND DESCRIPTION	FUNCTION	JAN OR NAVY TYPE DESIGNATION	STANDARD NAVY STOCK NUMBER	MANUFACTURERS		TELETYPE PART NO.	ALL SYMBOL DESIGNATIONS INVOLVED	TOTAL NO. PER EQUIP.	SPARE PARTS				
					CODE	DESIG.				EQUIP.		STOCK		
										BOX	QUAN.	BOX	QUAN.	
H-185	Same as H-126	Holds O-202 to O-207												
H-186	Same as H-118	Holds O-202 to O-207												
H-187	WASHER, flat: steel, nickel plated; round, approx 1/32" thk x 21/32" OD x 3/8" ID o/a	Spaces O-206 and O-203		N17-T-350013-698	CTT	151246	151246	H-187	1	-	-	-	-	
H-188	NUT, hexagon: steel, nickel plated; #10-32; approx 3/32" thk o/a; 5/16" across flats	Holds O-202 to O-207		N17-T-350004-694	CTT	112626	112626	H-188, H-287, H-309, H-312, H-1595, H-1689, H-1719, H-1726, H-1728, H-1898, H-2000, H-2110, H-2112, H-2115, H-2117	15	1	5	-	-	
H-189	WASHER, lock: steel; round, approx 11/32" OD x 3/16" ID x 0.047" thk o/a; split ring type	Holds O-202 to O-207		N17-T-350013-122	CTT	2669	2669	H-189, H-192, H-195, H-286, H-304, H-308, H-313, H-1594, H-1602, H-1612, H-1690, H-1720, H-1725, H-1727, H-1897, H-1923, H-1937, H-1999, H-2109, H-2113	24	1	10	-	-	
H-190	WASHER, flat: steel, nickel plated; round approx 7/16" OD x 3/16" ID x 0.050" thk o/a	Holds O-202 to O-207		N17-T-350005-622	CTT	3438	3438	H-190, H-395	2	1	2	-	-	
H-191	SCREW, machine: slot or wrench drive; Hex H; steel, nickel plated; #10-32; approx 15/32" lg o/a; 3/8" lg threaded portion; head 3/32" thk x 5/16" across flats	Holds O-208 to keyboard base		N17-T-350014-602	CTT	151723	151723	H-191	1	1	4	-	-	
H-192	Same as H-189	Holds O-208 to keyboard base												
H-193	BUTTON, pivot: steel, nickel plated; approx 1/2" OD x 3/16" ID x 5/32" thk o/a; mts by ID	Adjustment pivot for O-205		N17-T-350014-600	CTT	151712	151712	H-193	2	-	-	-	-	
H-194	SCREW, machine: slot or wrench drive; Hex H; steel, nickel plated; #10-32; approx 23/32" lg o/a; 5/8" lg threaded portion; head 3/32" thk x 5/16" across flats	Holds O-205 to keyboard base		N17-T-350014-603	CTT	151724	151724	H-194	2	-	-	-	-	
H-195	Same as H-189	Holds O-205 to keyboard base												
H-196	SCREW, machine: slot drive; FH; steel, nickel plated; #10-32; approx 27/32" lg o/a; 3/4" lg threaded portion; head approx 3/32" thk x 9/32" diam	Adjusts meeting of O-202 with O-505 or O-506 by raising or lowering O-205		N17-T-350014-604	CTT	151725	151725	H-196, H-303	2	-	-	-	-	
H-197	Same as H-132	Holds A-108 to keyboard base												

8-26

CHANGE 1



8-28

CHANGE 1

TABLE 8-4. COMBINED PARTS AND SPARE PARTS LIST

SYMBOL DESIG.	NAME OF PART AND DESCRIPTION	FUNCTION	JAN OR NAVY TYPE DESIGNATION	STANDARD NAVY STOCK NUMBER	MANUFAC- TURERS		TELETYPE PART NO.	ALL SYMBOL DESIGNATIONS INVOLVED	SPARE PARTS										
					MFG CODE	DESIG.			TOTAL NO. PER EQUIP.	EQUIP.		STOCK							
										BOX	QUAN.	BOX	QUAN.						
H-215	Same as H-201	Locks O-218 in position on O-217																	
H-216	Same as H-132	Holds A-111 to keyboard base																	
H-217	Same as H-118	Holds A-111 to keyboard base																	
H-218	Same as H-132	Holds A-110 to keyboard base																	
H-219	Same as H-118	Holds A-110 to keyboard base																	
H-220	SCREW, shoulder: slot drive; FH; steel, nickel plated; #4-40; approx 5/16" lg o/a; 3/16" lg threaded portion incl slot; head 1/16" thk x 5/16" diam; shoulder 1/16" lg x 5/32" diam	Holds O-219 to O-223		N17-T- 350013- 789	CTT	96717	96717	H-220, H-1321, H-1492	3	1	2	-	-						
H-221	Same as H-147	Holds O-219 to O-223																	
H-222	Same as H-106	Holds O-219 to O-223																	
H-223	Same as H-199	Retains O-221 to A-111																	
H-224	Same as H-201	Locks O-222 in position on O-221																	
H-225	Same as H-200	Locks O-222 in position on O-221																	
H-226	Same as H-201	Locks O-223 in position on O-221																	
H-227	Same as H-200	Locks O-223 in position on O-221																	
H-228	SCREW, shoulder: slot drive; FH; steel, nickel plated; #4-40; approx 1/4" lg o/a; 1/16" lg threaded portion; head 1/16" thk x 7/32" diam; shoulder 1/16" lg x 5/32" diam; slot between shoulder and threaded portion	Holds O-224 to O-227		N17-T- 350013- 677	CTT	151223	151223	H-228	2	1	1	-	-						
H-229	Same as H-126	Holds keytop guide plate and key lever cover to A-114																	
H-230	WINDOW, plastic: clear lucite, frosted finish 1 side; beveled 1 end, overlaps sides and other end; approx 2 1/8" wd x 4 11/32" lg x 1/8" thk o/a; mts by elliptical hole near 1 end or groove along other end	Protects data card		N17-T- 350014- 848	CTT	151353	151353	H-230	2	-	-	-	-						

8 Section  
H-215—H-230TT-47/UG, TT-48/UG, TT-69/UG, TT-70/UG  
NAVSHIPS 91393

PARTS LISTS

## PARTS LISTS

TT-47/UG, TT-48/UG, TT-69/UG, TT-70/UG

NAVSHIPS 91393

Section 8  
H-231-H-255

H-231	SCREW, machine: slot drive; FH; steel, black oxide finish; #2-56; approx 1/2" lg x 3/16" diam o/a; threaded portion 3/16" lg; head approx 3/16" diam x 1/16" thk	Holds H-230 to keytop guide plate	N17-T-350013-712	CTT	151354	151354	H-231	2	1	2	-	-
H-232	Same as H-157	Holds O-228 to O-227										
H-233	Same as H-106	Holds O-228 to O-227										
H-234	Same as H-157	Holds O-224 to O-228										
H-235	Same as H-106	Holds O-234 to O-228										
H-236	Same as H-151	Holds O-226 to A-115										
H-237	Same as H-147	Holds O-226 to A-115										
H-238	Same as H-104	Holds O-226 to A-115										
H-239	Same as H-132	Holds A-113 to A-114										
H-240	Same as H-118	Holds A-113 to A-114										
H-241	SCREW, pilot: slot drive; Hex head; steel, nickel plated; #6-40; approx 1/2" lg o/a; 5/16" lg threaded portion; head 1/16" thk x 1/4" across flats; pilot at 1 end of threaded portion	Pivot for O-227	N17-T-350013-678	CTT	151224	151224	H-241	2	1	1	-	-
H-242	Same as H-119	Locks H-241 in position										
H-243	SCREW, stop: slot drive; FH; steel, nickel plated; #4-40; approx 1/4" lg o/a; 3/32" lg threaded portion; head 1/16" lg x 5/32" diam; neck between head and threaded portion	Spaces O-229 and A-115	N17-T-350014-440	CTT	151074	151074	H-243	8	1	3	-	-
H-244	Same as H-106	Holds H-243 to A-115										
H-245	WASHER, flat: steel, nickel plated; round approx 3/8" OD x 1/8" ID x 0.065" thk o/a	Spaces O-229 and A-115	N17-T-350014-442	CTT	151080	151080	H-245	2	-	-	-	-
H-246	Same as H-151	Holds O-229 to A-115										
H-247	Same as H-147	Holds O-229 to A-115										
H-248	Same as H-121	Holds A-115 to A-114										
H-249	Same as H-118	Holds A-115 to A-114										
H-250	Same as H-125	Holds A-115 to A-114										
H-251	Same as H-201	Holds A-114 to A-116										
H-252	Same as H-118	Holds A-114 to A-116										
H-253	Same as H-121	Holds O-233 to A-116										
H-254	Same as H-132	Holds A-114 to A-116										
H-255	WASHER, flat: steel, nickel plated; round approx 9/32" OD x 5/32" ID x 0.028" thk o/a	Holds A-114 to A-116	N17-T-350013-624	CTT	91904	91904	H-255	3	1	1	-	-

CHANGE 1

8-29

TABLE 8-4. COMBINED PARTS AND SPARE PARTS LIST

SYMBOL DESIG.	NAME OF PART AND DESCRIPTION	FUNCTION	JAN OR NAVY TYPE DESIGNATION	STANDARD NAVY STOCK NUMBER	MANUFACTURERS		TELETYPE PART NO.	ALL SYMBOL DESIGNATIONS INVOLVED	TOTAL NO. PER EQUIP.	SPARE PARTS					
					CODE	DESIG.				EQUIP.		STOCK			
										BOX	QUAN.	BOX	QUAN.		
H-256	Same as H-199	Retains H-260 to O-239													
H-257	SCREW, machine: slot drive; hex head; steel, nickel plated; #4-40; approx 1/4" lg o/a; 3/16" lg threaded portion; head 1/16" thk x 3/16" across flats	Holds O-237 to O-236		N17-T-350014-476	CTT	151152	151152	H-257, H-332, H-341, H-350, H-360, H-378, H-634, H-636, H-656, H-1309, H-1328, H-1335, H-1341, H-1468, H-1470, H-1520, H-1646, H-1649, H-1652, H-1657, H-1687, H-1946, H-1957, H-2090, H-2094, H-2103, H-2121	47	1	10	-	-		
H-258	Same as H-147	Holds O-237 to O-236													
H-259	WASHER, flat: steel, nickel plated; round, approx 1/4" OD x 1/8" ID x 0.028" thk o/a	Holds O-237 to O-236		N17-T-350005-722	CTT	2034	2034	H-259, H-318, H-329, H-333, H-343, H-380, H-1145, H-1153	12	1	2	-	-		
H-260	SCREW, pilot: slot drive; FH; steel, nickel plated; 1/4" - 32; approx 1/8" lg o/a; 11/32" lg threaded portion; head 3/32" thk x 7/16" diam; shoulder 5/16" diam x 1/16" lg; c/o head; shoulder, slot, threaded portion, body w/slot near end	Pivot for and mounts O-239, O-237 and O-236 to A-118		N17-T-350014-421	CTT	151057	151057	H-260	1	1	1	-	-		
H-261	WASHER, flat: steel, nickel plated; round, approx 1/32" thk x 13/32" OD x 7/32" ID o/a	Holds O-239, O-237 and O-236 to A-118		N17-T-350013-683	CTT	151229	151229	H-261	1	1	1	-	-		
H-262	RING, retainer: steel, nickel plated; "C" shaped w/two internal cutouts; approx 5/32" OD x 1/16" ID x 0.010" thk o/a	Retains O-243 on O-244		N17-T-350013-797	WALDIS KOHLEN		119647	H-262, H-263	3	1	2	-	-		
H-263	Same as H-262	Retains O-245 on O-244													
H-264	RING, retainer: steel, nickel plated; "C" shaped w/two internal cutouts; approx 3/16" OD x 1/16" ID x 0.015" thk o/a	Retains H-283 to O-246		N17-T-350013-798	WALDIS KOHLEN		119648	H-264, H-275, H-338, H-347, H-349, H-1415, H-1424, H-1435, H-1436, H-1480, H-1553	12	1	5	-	-		
H-265	SCREW, pilot: slot drive; Fil H; steel, nickel plated; #4-40; approx 5/8" lg o/a; 7/16" lg threaded portion; head 1/16" thk x 5/32" diam; pilot at end of threaded portion	Pivot for O-260		N17-T-350014-411	CTT	151041	151041	H-265	1	1	1	-	-		
H-266	Same as H-106	Locks H-265 in position													
H-267	Same as H-119	Holds H-353 to A-118													
H-268	SCREW, machine: slot drive; FH; steel, nickel plated; #6-40; approx 13/16" lg o/a; 3/4" lg threaded portion; head 1/16" thk x 7/32" diam	Holds A-118 to keyboard base		N17-T-350013-759	CTT	151642	151642	H-268, H-614, H-1760, H-1806, H-1934	9	1	10	-	-		

8-30

CHANGE 1

## PARTS LISTS

## NAVSHIPS 91393

TT-47/UG, TT-48/UG, TT-69/UG, TT-70/UG

Section 8  
H-269-H-284

H-269	Same as H-118	Holds A-118 to keyboard base																		
H-270	Same as H-119	Locks H-283 in position																		
H-271	Same as H-118	Locks H-283 in position																		
H-272	Same as H-199	Retains O-249 on H-273																		
H-273	STUD: steel, nickel plated; approx 1 17/32" lg x 3/8" across flats o/a, shoulder 1/16" lg x 9/32" diam; one end threaded 7/32" lg w/#6-40 thd; shank w/slot one end, slot around ctr of body	Pivot for and mounts O-249 to A-118	N17-T-350014-713	CTT	151069	151069	H-273	1	1	1	-	-	-	-	-	-	-	-	-	-
H-274	SCREW, shoulder: slot drive; FH; steel, nickel plated; #6-40; approx 9/32" lg o/a; 5/32" lg threaded portion; head 1/16" thk x 1/4" diam; shoulder 1/16" lg x 3/16" diam; slot between shoulder and threaded portion	Guide for O-251	N17-T-350014-578	CTT	151206	151206	H-274	1	-	-	-	-	-	-	-	-	-	-	-	-
H-275	Same as H-264	Retains O-252 to H-276																		
H-276	STUD: steel, nickel plated; approx 15/16" lg x 5/16" OD o/a; 3/16" - 40 thd on body 3/8" lg; head end slotted, shank has slot near middle, shoulder slopes toward shank	Adjustment stud for O-275 and mounts O-252	N17-T-350014-410	CTT	151039	151039	H-276	1	1	1	-	-	-	-	-	-	-	-	-	-
H-277	Same as H-199	Retains H-281 to O-257																		
H-278	NUT, hexagon: steel, nickel plated; 3/16" - 40; 3/32" thk o/a; approx 5/16" across flats	Locks H-276 to O-257	N17-T-350012-487	CTT	5475	5475	H-278	1	1	1	-	-	-	-	-	-	-	-	-	-
H-279	Same as H-118	Holds O-253 to O-257																		
H-280	Same as H-119	Holds O-253 to O-257																		
H-281	STUD: steel, nickel plated; approx 1 7/8" lg o/a; 1 end threaded 3/16" lg w/#10-32 thd; hex head 5/16" across flats, shank on 1 end, body on other end w/groove near ea end, slot between body and cap	Pivot for O-257	N17-T-350014-579	CTT	151207	151207	H-281	1	-	-	-	-	-	-	-	-	-	-	-	-
H-282	POST, spring: steel, nickel plated; approx 5/8" lg x 1/8" diam o/a; mts by threaded end; groove near slotted end	Post for O-247	N17-T-350003-233	CTT	92668	92668	H-282	1	1	1	-	-	-	-	-	-	-	-	-	-
H-283	STUD: steel, nickel plated; approx 9/16" lg x 1/4" OD o/a, shoulder 1/16" lg x 1/8" OD; body threaded w/#6-40, 5/32" lg; c/o off ctr head w/slot near end, shoulder, body w/thd at end, shank on end of body w/slot across end	Pivot for O-246	N17-T-350014-581	CTT	151213	151213	H-283	1	-	-	-	-	-	-	-	-	-	-	-	-
H-284	POST, spring: steel, nickel plated; approx 3/8" lg x 1/8" diam o/a; mts by approx 5/32" lg threaded shank; c/o slotted head, neck, body, slot and shank	Post for O-250	N17-T-350002-228	CTT	80294	80294	H-284	1	1	1	-	-	-	-	-	-	-	-	-	-

CHANGE 1

8-31



TABLE 8-4. COMBINED PARTS AND SPARE PARTS LIST

SYMBOL DESIG.	NAME OF PART AND DESCRIPTION	FUNCTION	JAN OR NAVY TYPE DESIGNATION	STANDARD NAVY STOCK NUMBER	MANUFACTURERS		TELETYPE PART NO.	ALL SYMBOL DESIGNATIONS INVOLVED	TOTAL NO. PER EQUIP.	SPARE PARTS				
					CODE	DESIG.				EQUIP.		STOCK		
										BOX	QUAN.	BOX	QUAN.	QUAN.
H-285	POST, spring: steel, nickel plated; approx 3/8" lg x 1/8" diam o/a; mts by approx 3/32" lg threaded shank; c/o slotted head, neck, body, slot and shank	Post for O-256		N17-T-350013-621	CTT	86720	86720	H-285	1	1	1	-	-	
H-286	Same as H-189	Holds H-281 to A-118												
H-287	Same as H-188	Holds H-281 to A-118												
H-288	Same as H-118	Holds H-273 to A-118												
H-289	Same as H-119	Holds H-273 to A-118												
H-290	NUT, hexagon: steel, nickel plated; 1/4" - 32; 3/32" thk o/a; approx 3/8" across flats	Holds H-260 to A-118		N17-T-350005-740	CTT	3595	3595	H-290, H-1482	2	1	2	-	-	
H-291	SCREW, machine: slot drive; Fil H; steel, nickel plated; #2-56; approx 1/4" lg o/a; 3/16" lg threaded portion; head 1/16" thk x 1/8" diam	Holds O-259 to O-260		N17-T-350013-155	CTT	1164	1164	H-291, H-384, H-1854	6	1	2	-	-	
H-292	WASHER, lock: steel; round, approx 3/16" OD x 1/8" ID x 0.010" thk o/a; shake-proof type, straight internal teeth	Holds O-259 to O-260		N17-T-350013-243	CAXO	1202	90791	H-292, H-388, H-1844, H-1847	6	1	3	-	-	
H-293	WASHER, flat: steel, nickel plated; round, approx 3/16" OD x 3/32" ID x 0.020" thk o/a	Holds O-259 to O-260		N17-T-350013-188	CTT	71073	71073	H-293	2	1	1	-	-	
H-294	STUD: steel, nickel plated; approx 7/16" lg 3/16" across flats o/a; shank end thd #4-40 3/16" lg; c/o head, hex shoulder, slot and shank	Stop for O-236		N17-T-350014-418	CTT	151054	151054	H-294	1	1	1	-	-	
H-295	Same as H-147	Locks H-294 to A-118												
H-296	NUT, hexagon: steel, nickel plated; #4-40; 3/64" thk o/a; approx 3/16" across flats	Locks H-339 to O-279		N17-T-350009-576	CTT	86742	86742	H-296, H-317	2	1	1	-	-	
H-297	SCREW, pilot: slot and wrench drive; hex head; steel, nickel plated; 1/4" - 32; approx 1 1/16" lg o/a; 9/32" lg threaded portion; head 3/16" thk x 3/8" across flats; pilot 3/8" lg x 3/16" diam, tapered at end; split ring lock washer held captive between head and threaded portion	Holds right or left side frame to keyboard base		N17-T-350014-593	CTT	151678	151678	H-297	4	1	2	-	-	



TABLE 8-4. COMBINED PARTS AND SPARE PARTS LIST

SYMBOL DESIG.	NAME OF PART AND DESCRIPTION	FUNCTION	JAN OR NAVY TYPE DESIGNATION	PARTS			SPARE PARTS						
				STANDARD NAVY STOCK NUMBER	MANUFACTURERS		TELETYPE PART NO.	ALL SYMBOL DESIGNATIONS INVOLVED	TOTAL NO. PER EQUIP.	EQUIP.		STOCK	
					CODE	DESIG.				NO.	QUAN.	NO.	QUAN.
H-321	STUD: steel, nickel plated; approx 1/2" lg x 3/16" diam across flats o/a; shank end #4-40 thd, 3/16" lg; c/o body w/slot near end, hex head, slot and threaded shank	Swivel for O-280		N17-T-350014-422	CTT	151059	151059	H-321, H-339	2	1	1	-	-
H-322	RING, retainers: steel, nickel plated; "C" shaped w/two internal cutouts; approx 1/4" OD x 3/32" ID x 0.015" thk o/a	Retains O-280 to H-321		N17-T-350013-799	WALDES KOHINOOR INC	119649	119649	H-322, H-326, H-340, H-358, H-1610, H-2032	8	1	5	-	-
H-323	SCREW, shoulder: slot drive; FH; steel, nickel plated; #2-56; approx 1/4" lg o/a; 1/8" lg threaded portion; head 1/16" lg x 3/16" diam; shoulder 1/32" lg x 1/8" diam; slot between shoulder and threaded portion	Holds O-281 to O-280		N17-T-350014-471	CTT	151145	151145	H-323	1	-	-	-	-
H-324	NUT, hexagon: steel, nickel plated; #2-56; approx 1/16" thk o/a; 3/16" across flats	Holds O-281 to O-280		N17-T-350004-695	CTT	112627	112627	H-324, H-1843, H-1846	4	1	2	-	-
H-325	STUD: steel, nickel plated; approx 1/2" lg x 1/4" diam o/a, shoulder 1/16" lg x 1/8" diam; shank end #4-40 thd 3/16" lg; body has slot near end, head has two cutouts	Pivot for O-283		N17-T-350014-457	CTT	151098	151098	H-325	1	1	1	-	-
H-326	Same as H-322	Retains O-283 to H-325											
H-327	STUD: steel, nickel plated; approx 9/16" lg x 3/16" across flats; 1 end threaded 1/8" lg w/#4-40 thd; c/o hex head, body w/slot near end on 1 side and threaded shank on other side	Pivot for O-285 and holds O-292 to O-279		N17-T-350014-575	CTT	151203	151203	H-327	1	-	-	-	-
H-328	Same as H-147	Locks H-327 to O-279											
H-329	Same as H-259	Locks H-327 to O-279											
H-330	RING, retainer: steel, nickel plated; "C" shape w/two internal cutouts; approx 9/32" OD x 1/8" ID x 0.025" thk o/a	Retains O-285 to H-327		N17-T-350013-301	WALDES KOHINOOR INC	119651	119651	H-330, H-331, H-1301, H-1352, H-1357, H-1374, H-1380, H-1392, H-1473, H-1535, H-1540, H-1568, H-1571, H-1645, H-1654, H-1663, H-1668, H-1677, H-1684, H-1875, H-1981, H-2041, H-2044, H-2067, H-2068	27	1	10	-	-
H-331	Same as H-330	Retains O-286 to O-285											
H-332	Same as H-257	Holds A-119 to O-279											
H-333	Same as H-259	Holds A-119 to O-279											



TABLE 8-4. COMBINED PARTS AND SPARE PARTS LIST

SYMBOL DESIG.	NAME OF PART AND DESCRIPTION	FUNCTION	JAN OR NAVY TYPE DESIGNATION	PARTS			TELETYPE PART NO.	ALL SYMBOL DESIGNATIONS INVOLVED	TOTAL NO. PER EQUIP.	SPARE PARTS								
				STANDARD NAVY STOCK NUMBER	MANUFAC- TURERS					EQUIP.	STOCK							
					CODE	DESIG.						BOX	QUAN.	BOX	QUAN.			
H-364	Same as H-129	Locks H-310																
H-365	SCREW, machine: slot drive; FH; steel, nickel plated; #6-40; approx 7/16" lg o/a; 9/32" lg threaded portion incl slot; 1/16" thk x 1/4 diam head; 5/32" diam x 3/32" lg shoulder	Holds O-279 to A-118		N17-T-350014-907	CTT	151832	151832	H-365	2	-	-	-	-					
H-366	WASHER, lock: steel; round, approx 9/32" OD x 5/32" ID x 1/32" thk o/a; split ring type	Holds O-279 to A-118		N17-T-350013-124	CTT	3646	3646	H-366, H-798, H-1110, H-1148	6	-	-	-	-					
H-367	STUD: steel, nickel plated; approx 1 1/8" lg x 3/16" across flats; 1 end threaded 3/32" lg w/#4-40 thd; c/o threaded shank, slot, hex shoulder and body w/slot across end	Stop for O-351 through O-357		N17-T-350014-419	CTT	151055	151055	H-367	1	1	1	-	-					
H-368	STUD: steel, nickel plated; approx 1/4" lg x 3/16" across flats o/a; #4-40 threaded portion of body 1/8" lg; hex head between body and shank	Pivot for O-260		N17-T-350014-412	CTT	151042	151042	H-368	1	1	1	-	-					
H-371	Same as H-147	Locks H-368 to O-279																
H-372	NUT, cap: hex cap, round body; steel, nickel plated; #4-40; approx 1/8" h; 3/16" wd across flats	Locks H-368 to O-279		N17-T-350014-908	CTT	151812	151812	H-372	1	-	-	-	-					
H-373	SCREW, adjustment: steel, nickel plated	Adjusts A-120		N17-T-350014-486	CTT	151169	151169	H-373	1	-	-	-	-					
H-374	SCREW, machine: slot drive; FH; steel, nickel plated; #4-40; approx 15/16" lg o/a; threaded portion 7/8" lg; head 3/16" diam x 1/16" thk	Holds E-103, A-121 and A-112 to A-120		N17-T-350014-887	CTT	151731	151731	H-374, H-1955	3	1	1	-	-					
H-375	Same as H-147	Holds E-103, A-121 and A-112 to A-120																
H-376	SCREW, machine: slot drive; Fil H; steel, nickel plated; #4-40; approx 3/8" lg o/a; 9/32" lg threaded portion; 3/16" diam x 1/16" thk head	Holds E-103 and A-121 to A-120		N17-T-350004-117	CTT	102052	102052	H-376	1	1	1	-	-					
H-377	Same as H-147	Holds E-103 and A-121 to A-120																
H-378	Same as H-257	Holds A-120 to O-279																
H-379	Same as H-147	Holds A-120 to O-279																
H-380	Same as H-259	Holds A-120 to O-279																
H-384	Same as H-291	Holds O-306 to E-103																

CHANGE 1

8-37

H-385	WASHER, lock: steel; round, approx 5/32" OD x 3/32" ID x 0.015" thk o/a; split ring type	Holds O-306 to E-103	N17-T-350013-614	CTT	93118	93118	H-385	2	1	2	-	-	-	-
H-386	Same as H-106	Locks H-373 to O-279												
H-387	SCREW, machine: slot drive; Fil H; steel, nickel plated; #2-56; approx 5/16" lg o/a; 1/4" lg threaded portion; head 1/8" diam x 0.068" thk	Holds O-307 to O-225	N17-T-350005-763	CTT	5740	5740	H-387, H-1404	2	1	3	-	-	-	-
H-388	Same as H-292	Holds O-307 to O-225												
H-389	WASHER, insulating: natural or black bakelite; round, approx 9/32" OD x 3/32" ID x 0.015" thk o/a	Holds O-307 to O-225	N17-T-350014-478	CTT	151182	151182	H-389	1	1	1	-	-	-	-
H-390	Same as H-106	Locks A-112 to E-103												
H-391	Same as H-199	Retains A-111 to O-221												
H-392	WASHER, flat: steel, nickel plated; round, approx 1/2" OD x 1/4" ID x 0.030" thk o/a	Holds H-260 to A-118	N17-T-350012-310	CTT	111767	111767	H-392	1	-	-	-	-	-	-
H-393	SCREW, machine: slot or wrench drive; Hex H; steel, nickel plated; 1/4" - 32; approx 2" lg o/a; 7/16" lg threaded portion; head 1 9/16" lg x 5/16" across flats	Holds keyboard base to CY-870/UG or CY-871/UG	N17-T-350014-862	CTT	151549	151549	H-393	4	-	-	-	-	-	-
H-394	Same as H-104	Holds O-312 to O-279												
H-395	Same as H-190	Holds O-208 to keyboard base												
H-396	SCREW, pilot: slot drive; FH; steel, nickel plated; #4-40; approx 3/8" lg o/a; 3/32" lg threaded portion; 1/16" thk x 3/16" diam head; 3/32" diam x 7/32" lg pilot	Stop for O-280		CTT	6801	6801	H-396	1	-	-	-	-	-	-
H-397	Same as H-147	Holds H-396 to A-119												
H-398	WASHER, lock: stainless steel; round, approx 13/32" OD x 3/16" ID x 0.022" thk o/a; shakeproof-type, twisted external teeth	Holds keyboard base to CY-870/UG or CY-871/UG	N17-T-350014-929	CTT	151572	151572	H-398	4	-	-	-	-	-	-
H-399	NUT, cap: round; steel, nickel plated; #4-40; approx 7/32" lg o/a; 3/16" diam body, 5/16" diam knurled cap	Holds O-142, O-143 and A-107 to A-106	N17-T-350014-884	CTT	151829	151829	H-399	2	-	-	-	-	-	-
H-400	WASHER, flat: steel, nickel plated; round, approx 5/16" OD x 5/32" ID x 0.035" thk o/a	Holds O-279 to A-118	N17-T-350005-725	CTT	2247	2247	H-400	2	-	-	-	-	-	-
H-401	Same as H-322	Retains O-366 on H-273												
H-501	SCREW, machine: slot drive; RH; steel, cadmium plated; #6-32; approx 19/32" lg o/a; 1/2" lg threaded portion; head 3/32" thk x 1/4" diam	Holds A-501 to O-501	N43-S-68898-1050	OG	#N37-P13008C	122257	H-501, H-506	5	-	-	-	-	-	-

PARTS LISTS

TT-47/UG, TT-48/UG, TT-69/UG, TT-70/UG

NAVSHIPS 91393

Section 8  
H-385-H-501

TABLE 8-4. COMBINED PARTS AND SPARE PARTS LIST

SYMBOL DESIG.	NAME OF PART AND DESCRIPTION	FUNCTION	JAN OR NAVY TYPE DESIGNATION	PARTS			TELETYPE PART NO.	ALL SYMBOL DESIGNATIONS INVOLVED	TOTAL NO. PER EQUIP.	SPARE PARTS			
				STANDARD NAVY STOCK NUMBER	MANUFAC- TURERS					EQUIP.	STOCK		
					DE SIG.	DESIG.					BOX	QUAN.	BOX
H-502	STRAP, mounting: approx 2 1/4" lg x 1 3/4" h x 3/8" wd o/a; steel, cadmium plated; strap adjusted by screw and nut; 2 identical sides irregularly formed, elongated slot near 1 end, extruded section near other end	Straps PD-17/U to A-503 or PD-17A/U to A-505		N17-T-350013-804	CG	#115A82 4AA4	122207	H-502, H-671	4	-	-	-	-
H-503	SCREW, machine: slot drive; RH; steel, cadmium plated; #6-32; approx 13/32" lg o/a; 5/16" lg threaded portion; head 3/32" thk x 1/4" diam	Holds S-501 to S-502		N43-S-68898-1035	CG	#N37- P13005C	122256	H-503	2	-	-	-	-
H-504	Same as H-118	Holds S-501 to S-502											
H-505	Same as H-125	Holds S-501 to S-502											
H-506	Same as H-501	Holds S-502 to O-503											
H-507	Same as H-118	Holds S-502 to O-503											
H-508	Same as H-125	Holds S-502 to O-503											
H-509	SCREW, machine: slot drive; Fil H; steel, nickel plated; #6-40; approx 9/16" lg o/a; 7/16" lg threaded portion; head 1/8" thk x 7/32" diam	Holds A-502 to E-501		N17-T-350013-160	CTT	1169	1169	H-509	1	-	-	-	-
H-510	Same as H-118	Holds A-502 or E-501 to E-501											
H-511	SCREW, machine: slot drive; RH; steel, cadmium plated; #8-32; approx 1/2" lg o/a; 3/8" lg threaded portion; head 9/32" diam x 1/8" thk	Holds S-503 to A-502		N43-S-68898-1340	CG	#N37- P15006C	122258	H-511	2	-	-	-	-
H-512	WASHER, lock: steel, nickel plated; round, approx 3/8" OD x 1/8" ID x 0.020" thk o/a; shakeproof type, straight external teeth	Holds S-503 to A-502		N43-W-6798-280	CAXO	1108	92527	H-512, H-802, H-1138	7	-	-	-	-
H-513	NUT, hexagon: brass, nickel plated; #8-32; approx 1/8" thk o/a; 3/8" across flats	Holds S-503 to A-502		N17-T-350006-929	CTT	49514	49514	H-513, H-804, H-1111	8	-	-	-	-
H-514	WASHER, flat: steel, nickel plated; round, approx 3/8" OD x 3/16" ID x 0.042" thk o/a	Holds O-503 and O-504 or O-512 to O-501		N17-T-350014-928	CTT	117535	117535	H-514	2	-	-	-	-
H-515	NUT, hexagon: steel, nickel plated; #8-32; 5/32" thk; 5/16" across flats	Holds O-503 and O-504 or O-512 to O-501		N17-T-350005-565	CTT	2263	2263	H-515	2	-	-	-	-
H-516	SCREW, machine: slot drive; Hex H; steel, nickel plated; #6-40; approx 3/8" lg o/a; 5/16" lg threaded portion; head 1/4" across flats x 1/16" thk	Holds O-505 or O-506 to O-207		N17-T-350013-754	CTT	151631	151631	H-516, H-1330, H-1350, H-1377, H-1384, H-1625, H-1641, H-1773, H-2069, H-2152	18	1	2	-	-





TABLE 8-4. COMBINED PARTS AND SPARE PARTS LIST

SYMBOL DESIG.	NAME OF PART AND DESCRIPTION	FUNCTION	JAN OR NAVY TYPE DESIGNATION	STANDARD NAVY STOCK NUMBER	MANUFACTURERS		TELETYPE PART NO.	ALL SYMBOL DESIGNATIONS INVOLVED	TOTAL NO. PER EQUIP.	SPARE PARTS				
					CODE	DESIG.				EQUIP.		STOCK		
										X	Q	X	Q	
H-601	Same as H-121	Holds A-605 to A-606												
H-602	Same as H-118	Holds A-605 to A-606												
H-603	Same as H-141	Holds O-602 to A-606												
H-604	Same as H-118	Holds O-602 to A-606												
H-605	Same as H-125	Holds O-602 to A-606												
H-606	Same as H-141	Holds E-601 and A-605 to A-606												
H-607	Same as H-118	Holds E-601 and A-605 to A-606												
H-608	Same as H-141	Holds A-607 to A-606												
H-609	Sam as H-118	Holds A-607 to A-606												
H-610	Same as H-125	Holds A-607 to A-606												
H-611	Same as H-141	Holds O-601 to A-609												
H-612	Same as H-118	Holds O-601 to A-609												
H-613	Same as H-125	Holds O-601 to A-609												
H-614	Same as H-268	Holds A-609 to O-610												
H-615	Same as H-118	Holds A-609 to O-610												
H-616	Same as H-141	Holds E-602 and A-608 to A-609												
H-617	Same as H-118	Holds E-602 and A-608 to A-609												
H-618	Same as H-121	Holds A-608 to A-609												
H-619	Same as H-118	Holds A-608 to A-609												
H-620	Same as H-141	Holds A-610 to A-609												
H-621	Same as H-118	Holds A-610 to A-609												
H-622	Same as H-125	Holds A-610 to A-609												
H-623	SCREW, machine: slot drive; FH; steel, nickel plated; #6-40; approx 5/16" lg o/a; 1/4" lg threaded portion; head 1/16" thk x 7/32" diam	Holds A-606 and O-603 to O-610		N17-T-350014-592	CTT	151661	151661	H-623, H-625, H-642, H-1175, H-1613	5	-	-	-	-	-
H-624	Same as H-118	Holds A-606 and O-603 to O-610												
H-625	Same as H-623	Holds A-606 and A-609 to O-610												
H-626	Same as H-118	Holds A-606 and A-609 to O-610												
H-627	SCREW, machine: slot drive; FH; steel, nickel plated; #4-40; approx 3/4" lg o/a; thd portion 1/2" lg; head 1/8" lg x 3/32" diam; shoulder 1/32" lg x 1/4" diam	Adjusts tension of O-604		N17-T-350014-378	CTT	150865	150865	H-627	1	-	-	-	-	-

8-40

CHANGE 1



TABLE 8-4. COMBINED PARTS AND SPARE PARTS LIST

SYMBOL DESIG.	NAME OF PART AND DESCRIPTION	FUNCTION	JAN OR NAVY TYPE DESIGNATION	STANDARD NAVY STOCK NUMBER	MANUFACTURERS		TELETYPE PART NO.	ALL SYMBOL DESIGNATIONS INVOLVED	SPARE PARTS				
					MANUF. CODE	DESIG.			TOTAL NO. PER EQUIP.	EQUIP.		STOCK	
										BOX	QUAN.	BOX	QUAN.
H-659	CLAMP: steel; nickel plated; approx 5/16" lg x 1/4" h x 3/16" wd o/a, 0.035" thk material; formed at 1 end, mts by hole in lg side	Clamps E-606 to A-603		N17-T-350014-375	CTT	150857	150857	H-659	1	-	-	-	-
H-660	SCREW, captive: slot drive; RH; steel, cadmium plated; #8-32; approx 3/8" lg o/a; 3/16" lg threaded portion; head 1/8" thk x 5/16" diam	Holds ground terminalsof C-603 or C-601 to O-610		N43-S-68898-1330	CG	#N37P 15004C	122219	H-660, H-685	3	-	-	-	-
H-661	Same as H-650	Holds H-664 to O-610											
H-662	Same as H-118	Holds H-664 to O-610											
H-663	SCREW, machine: slot drive; FH; iron, nickel plated; #6-32; approx 3/8" lg o/a; 5/16" lg threaded portion; head 1/16" thk x 1/4" diam	Holds H-664 to O-610		N17-T-350001-128	CTT	125143	125143	H-663	1	-	-	-	-
H-664	CLAMP: approx 1 15/16" lg x 1/2" wd x 3/8" h o/a, 0.018" thk material; formed in ctr and both ends, body hole in ctr	Clamps C-601 and C-603 to O-610		N17-C-781697-410	CG	#87632	122203	H-664	1	-	-	-	-
H-665	WASHER, flat: fiber; round, approx 1 1/2" OD x 17/32" ID x 0.010" thk o/a	Keeps carbon dust from E-607 and E-608 from walls of O-610		N17-T-350013-805	CTT	122232	122232	H-665	2	-	-	-	-
H-666	ROD: steel, cadmium plated; approx 3 1/2" lg x 3/16" diam o/a; both ends threaded w/#10-32 thd 1/2" lg	Holds O-610, O-614 and O-615 together		N17-T-350013-802	CG	#5828 772AA 25	122202	H-666	2	-	-	-	-
H-667	NUT, hexagon: brass; #10-32; approx 3/16" thk; 5/16" across flats	Holds O-610, O-614 and O-615 together		N17-T-350001-166	CG	1720905	125009	H-667	2	-	-	-	-
H-668	Same as H-526	Base for O-611											
H-670	Same as H-126	Holds O-507 or O-508 to E-609											
H-671	Same as H-502	Holds PD-18/U to A-611											
H-672	Same as H-118	Holds O-507 or O-508 to E-609											
H-680	Same as H-310	Holds A-611 to keyboard base											
H-681	Same as H-311	Holds A-611 to keyboard base											
H-682	HOLDER, contact brush: brass body w/bakelite insulator; 2 grooves around shank end, wd slot at other end; approx 1 1/4" lg x 11/16" OD x 11/32" ID o/a; mts by body; 2 slots, in line, through ID	Holder for E-607 or E-608		N17-H-71773-1911	CG	#5899 504AF1	122206	H-682	2	-	-	-	-
H-685	Same as H-660	Ground for H-684											
H-686	Same as H-527	Pull washer for removing O-618 and O-619 from E-609											
H-687	Same as H-257	Holds A-613 and A-615 to A-611											

CHANGE 1

H-688	Same as H-147	Holds A-613 and A-615 to A-611																	
H-689	Same as H-257	Holds A-614 to A-615																	
H-690	Same as H-147	Holds A-614 to A-615																	
H-691	Same as H-257	Holds A-616 to A-615																	
H-692	Same as H-147	Holds A-616 to A-615																	
H-693	Same as H-1493	Holds A-612 to O-610																	
H-694	Same as H-118	Holds A-612 to O-610																	
SYMBOL DESIGNATIONS H-702 TO H-704 INCL USED ON CY-870/UG CABINET ONLY																			
H-702	SCREW, machine: wrench drive; Hex H; steel, nickel plated; 3/8" - 16; approx 2 9/32" lg o/a; threaded portion 1 1/4" lg; head 9/32" thk x 9/16" across flats	Holds A-701 to CY-870/UG		N17-T-350014-394	CTT	86433	86433	H-702	4	-	-	-	-	-	-	-	-	-	-
H-703	WASHER, lock: steel; round, approx 1 1/16" OD x 3/8" ID x 0.070" thk o/a; split ring type	Holds A-701 to CY-870/UG		N17-T-350005-735	CTT	2920	2920	H-703	4	-	-	-	-	-	-	-	-	-	-
H-704	NUT, hexagon: steel, nickel plated; 3/8" - 16; 1/4" thk; 5/8" across flats	Holds A-701 to CY-870/UG		N17-T-350012-693	CTT	103612	103612	H-704	4	-	-	-	-	-	-	-	-	-	-
SYMBOL DESIGNATIONS H-751 TO H-824 INCL USED ON CY-870/UG AND CY-871/UG CABINETS																			
H-751	WINDOW: homalite; 1 beveled edge; approx 1 1/2" lg x 3 3/8" h x 3/16" thk o/a; mts by edges slid in place	Copy window for cabinet dome		N17-T-350014-762	CTT	151510	151510	H-751	1	-	-	-	-	-	-	-	-	-	-
H-752	BUTTON: tenite; approx 3/4" large diam and 5/8" shoulder diam x 3/8" thk o/a; mts by shoulder; face sand blast finished	Red window for I-751		N17-T-350014-776	CTT	151557	151557	H-752	1	-	-	-	-	-	-	-	-	-	-
H-753	NUT, lock: push on type; steel, nickel plated; 0.016" thk; approx 1" lg x 13/16" wd; hex hole, curved surface	Holds H-752 to cabinet dome		N43-N-9699-190	TINBERMAN PRODUCTS	151558	151558	H-753	3	-	-	-	-	-	-	-	-	-	-
H-754	SCREW, shoulder: slot drive; FH; steel, nickel plated; #10-32; approx 7/16" lg o/a; approx 3/16" lg thd; head approx 3/32" thk x 3/8" diam; shoulder approx 3/32" thk x 1/4" diam	Pivot for and holds O-756 to cabinet		N17-T-350014-769	CTT	151534	151534	H-754	1	-	-	-	-	-	-	-	-	-	-
H-755	Same as H-140	Holds TB-751, TB-752 or TB-753 to cabinet and mounts A-751																	
H-756	Same as H-118	Holds A-751 to H-755																	

8-43

TABLE 8-4. COMBINED PARTS AND SPARE PARTS LIST

SYMBOL DESIG.	NAME OF PART AND DESCRIPTION	FUNCTION	JAN OR NAVY TYPE DESIGNATION	STANDARD NAVY STOCK NUMBER	MANUFAC- TURERS		TELETYPE PART NO.	ALL SYMBOL DESIGNATIONS INVOLVED	TOTAL NO. PER EQUIP.	SPARE PARTS			
					MFG C	DESIG.				EQUIP.		STOCK	
										BOX	QUAN.	BOX	QUAN.
H-757	SCREW, machine: slot drive; Fil H; steel, nickel plated; #6-40; approx 5/16" lg o/a; 1/4" lg threaded portion; head 1/16" thk x 1/4" diam	Holds A-751 to H-755		N17-T-350006-753	CTT	8543	8543	H-757	6	-	-	-	-
H-758	STUD: steel, nickel plated; approx 1 11/16" lg x 1/2" across flats o/a; 1 end threaded 13/16" lg, other end threaded 5/16" lg w/1/4" - 32 thd	Holds H-818 and side cradle rail to A-753 and A-754 or A-702		N17-T-350014-765	CTT	151521	151521	H-758	4	-	-	-	-
H-759	Same as H-311	Holds H-758 to A-753 and A-754 or A-702											
H-760	NUT, hexagon: steel, nickel plated; 1/4" - 32; 3/32" thk o/a; approx 7/16" across flats	Holds H-758 to A-753 and A-754 or A-702		N17-T-350001-159	CTT	125218	125218	H-760, H-820	8	-	-	-	-
H-767	SCREW, shoulder: slot drive; FH; steel, nickel plated; #6-40; approx 5/8" lg o/a; threaded portion 7/32" lg; head 1/8" lg x 9/32 diam; shoulder 1/4" lg x 3/16" diam; slot between head and shoulder	Holds O-759 and O-760 to cabinet dome		N17-T-350007-862	CTT	74011	74011	H-767	2	-	-	-	-
H-768	WASHER, flat: steel, nickel plated; round, approx 11/32" OD x 3/16" ID x 1/32" thk o/a	Pressure point for O-759		N17-T-350006-840	CTT	34432	34432	H-768	2	-	-	-	-
H-769	WASHER, lock: steel, nickel plated; round, approx 5/16" OD x 5/32" ID x 0.018" thk o/a; shakeproof type, straight external teeth	Holds O-759 and O-760 to cabinet dome		N17-T-350014-922	CTT	107116	107116	H-769	2	-	-	-	-
H-770	Same as H-119	Holds O-759 and O-760 to cabinet dome											
H-771	NUT, hexagon: iron, nickel plated; #10-32; approx 1/8" thk o/a; 3/8" across flats	Holds H-773 to cabinet dome		N17-T-350001-165	CTT	125231	125231	H-771, H-780, H-783, H-789, H-792, H-823	22	-	-	-	-
H-772	WASHER, lock: steel; round, approx 11/32" OD x 3/16" ID x 1/16" thk o/a; split ring type	Holds H-773 to cabinet dome		N17-T-350005-753	CTT	3639	3639	H-772, H-776, H-779, H-782, H-788, H-791, H-822, H-2124	24	-	-	-	-
H-773	CLAMP: cable; cellulose plastic; 1 bolt employed; approx 5/16" h x 1/2" wd x 3/4" lg o/a; accommodates 3/16" diam cable; 1 mtg hole	Clamps XI-751 to cabinet dome		N17-C-780767-838	COMMERCIAL PLASTIC CO. CPC-742-3		121243	H-773, H-809, H-1398	3	-	-	-	-
H-774	SCREW, machine: slot drive; Hex H; steel, nickel plated; #10-32; approx 1/2" lg o/a; 3/8" lg threaded portion, head 1/8" thk x 5/16" across flats	Holds H-773 to cabinet dome		N17-T-350012-646	CTT	6810	6810	H-774	1	-	-	-	-

## PARTS LISTS

NAVSHIPS 91393  
TT-47/UG, TT-48/UG, TT-69/UG, TT-70/UGSection 8  
H-775-H-796

H-775	SCREW; slot drive; FH; stainless steel; #10-32; approx 5/8" lg o/a; threaded portion 9/32" lg; head 3/32" lg x 3/8" diam; shoulder 1/8" lg x 1/4" diam	Pivot for and holds O-762 to cabinet dome	N43-S-99500-112	CTT	100184	100184	H-775, H-778, H-790	3	-	-	-	-
H-776	Same as H-772	Holds O-762 to cabinet dome										
H-777	NUT, hexagon; steel, nickel plated; #10-32; 3/8" thk; 1/2" wd across flats; 5/16" thk round part	Holds O-762 to cabinet dome	N17-T-350014-395	CTT	102751	102751	H-777	1	-	-	-	-
H-778	Same as H-775	Pivot for and holds O-762 to A-756										
H-779	Same as H-772	Holds O-762 to A-756										
H-780	Same as H-771	Holds O-762 to A-756										
H-781	SCREW, machine; slot or wrench drive; Hex H; steel, nickel plated; #10-32; approx 3/4" lg o/a; 5/8" lg threaded portion; head 1/8" thk x 5/16" across flats	Holds T-751 and H-809 or H-813 to cabinet dome	N17-T-350004-826	CTT	78301	78301	H-781	2	-	-	-	-
H-782	Same as H-772	Holds T-751 and H-809 or H-813 to cabinet dome										
H-783	Same as H-771	Holds T-751 and H-809 or H-813 to cabinet dome										
H-787	SCREW, shoulder; slot drive; FH; steel, nickel plated; #10-32; approx 5/8" lg o/a; 1 1/32" lg threaded portion incl slot; head 3/32" thk x 1/2" diam; shoulder 3/16" lg x 1/4" diam	Pivot for and holds O-765 to cabinet dome	N17-T-350013-618	CTT	85529	85529	H-787	1	-	-	-	-
H-788	Same as H-772	Holds O-765 to cabinet dome										
H-789	Same as H-771	Holds O-765 to cabinet dome										
H-790	Same as H-775	Pivot for and holds O-766 to cabinet										
H-791	Same as H-772	Holds O-766 to cabinet										
H-792	Same as H-771	Holds O-766 to cabinet										
H-793	SCREW, thumb; knurled thumb head; steel, nickel plated; #10-32; approx 1 11/16" lg; approx 1 5/16" thd length; oval end; head approx 3/16" thk x 1/2" diam; shoulder approx 3/16" thk x 5/16" diam	Holds cross bar to cabinet	N17-T-350014-244	CTT	151526	151526	H-793	2	-	-	-	-
H-794	SCREW, machine; slot drive; Fil H; brass; #4-40; approx 5/16" lg o/a; 7/32" lg threaded portion; head 1/16" thk x 1/4" diam	Stop for E-755	N17-T-350013-133	CTT	1028	1028	H-794, H-1450	5	-	-	-	-
H-795	Same as H-118	Holds H-794 to A-757										
H-796	NUT, hexagon; steel, nickel plated; #4-40; approx 1/16" thk o/a; 1/4" across flats	Holds H-794 to A-757	N17-T-350001-164	CTT	110435	110435	H-796, H-1143, H-1155, H-1499, H-1841, H-1859, H-2020, H-2050, H-2147	12	1	2	-	-

CHANGE 1

8-45

TABLE 8-4. COMBINED PARTS AND SPARE PARTS LIST

SYMBOL DESIG.	NAME OF PART AND DESCRIPTION	FUNCTION	JAN OR NAVY TYPE DESIGNATION	STANDARD NAVY STOCK NUMBER	MANUFAC- TURERS		TELETYPE PART NO.	ALL SYMBOL DESIGNATIONS INVOLVED	SPARE PARTS				
					CODE	DESIG.			TOTAL NO. PER EQUIP.	EQUIP.		STOCK	
										BOX	QUAN.	BOX	QUAN.
H-797	SCREW, machine: slot drive; Fil H; iron, nickel plated; #8-32; approx 1/2" lg o/a; 3/8" lg threaded portion; head 3/32" thk x 1/4" diam	Holds E-756 to A-757		N17-T-350001-597	CTT	55219	55219	H-797, H-803	5	-	-	-	-
H-798	Same as H-366	Holds E-756 to A-757											
H-799	WASHER, flat: steel, nickel plated; approx 5/32" ID x 3/8" OD x 1/32" thk o/a	Holds O-768 and I-752 to cabinet		N17-T-350012-636	CTT	125015	125015	H-799, H-2056, H-2173, H-2174	7	1	1	-	-
H-800	Same as H-118	Holds O-768 and I-752 to cabinet											
H-801	SCREW, machine: slot drive; Fil H; steel, nickel plated; #6-40; approx 1/2" lg o/a; 3/8" lg threaded portion; head approx 1/8" thk x 7/32" diam	Holds O-768 and I-752 to cabinet		N17-T-350012-638	CTT	1026	1026	H-801	1	-	-	-	-
H-802	Same as H-512	Holds Z-751 or Z-752 to cabinet											
H-803	Same as H-797	Holds Z-751 or Z-752 to cabinet											
H-804	Same as H-513	Holds Z-751 or Z-752 to cabinet											
H-805	SCREW, machine: slot drive; Hex H; steel, nickel plated; #6-40; approx 5/16" lg o/a; 7/32" lg threaded portion; head 3/32" thk x 1/4" across flats	Holds XE-751 or XE-752 to cabinet dome		N17-T-350012-657	CTT	74059	74059	H-805, H-810	3	-	-	-	-
H-806	Same as H-118	Holds XE-751 or XE-752 to cabinet dome											
H-807	Same as H-125	Holds XE-751 or XE-752 to cabinet dome											
H-808	Same as H-119	Holds XE-751 or XE-752 to cabinet dome											
H-809	Same as H-773	Clamps W-751 to cabinet											
H-810	Same as H-805	Holds XI-751 to cabinet dome											
H-811	Same as H-118	Holds XI-751 to cabinet dome											
H-812	Same as H-119	Holds XI-751 to cabinet dome											
H-813	CLAMP: cable clamp; steel; nickel plated; approx 1" lg x 1/2" wd x 11/32" h o/a; 0.032" thk material; accommodated 5/16" diam cable	Clamps cable from T-751 to cabinet		N17-T-350014-895	CTT	8254	8254	H-813	1	-	-	-	-

H-814	CLAMP: cable clamp; steel; cadmium plated; 2 bolts employed; approx 1 15/16" lg x 1 1/4" h x 1 3/8" wd o/a; accommodates 9/16" diam cable; mts by 1/2" pipe thd and bonnut one end; curved 90°	Clamps power cable to Z-751		APPLETON ELEC. CO. 7380V	94660	H-814, H-815	2	-	-	-	-	
H-815	Same as H-814	Clamps line cable to Z-752										
H-816	Same as H-125	Holds XI-751 to cabinet dome										
H-817	WASHER, flat: steel, nickel plated; round, approx 1/2" OD x 1/4" ID x 1/32" thk o/a	Spaces side cradle rail from A-753 and A-754 or A-702	N17-T-350007-582	CTT	71858	71858	H-817	20	-	-	-	-
H-818	GUIDE, cable: steel; 9/16" diam cable; approx 1 3/4" lg x 1" wd x 0.065" thk o/a; one elongated mtg hole	Front guide for W-1101	N17-T-350014-902	CTT	151955	151955	H-818	2	-	-	-	-
H-819	Same as H-311	Holds H-818 and side cradle rail to A-753 and A-754 or A-702										
H-820	Same as H-760	Holds H-818 and side cradle rail to A-753 and A-754 or A-702										
H-821	SCREW, machine: slot drive; RH; iron nickel plated; #10-32; approx 1/2" lg o/a; 3/8" lg threaded portion; head 1/8" thk x 11/32" diam	Holds A-753 and A-754 to CY-871/UG or A-702 to CY-870/UG	N17-T-350006-703	CTT	8333	8333	H-821	16	-	-	-	-
H-822	Same as H-772	Holds A-753 and A-754 to CY-871/UG or A-702 to CY-870/UG										
H-823	Same as H-771	Holds A-753 and A-754 to CY-871/UG or A-702 to CY-870/UG										
H-824	GUIDE, cable: steel; 9/16" diam cable; approx 4" lg x 1 1/2" h x 0.065" thk o/a; two mtg holes in curved end	Rear guide for W-1101	N17-T-350014-896	CTT	151956	151956	H-824	2	-	-	-	-
H-1101	Same as H-121	Holds A-1107 to A-1108										
H-1102	Same as H-121	Holds O-1101 to A-1101										
H-1103	Same as H-118	Holds O-1101 to A-1101										
H-1104	WASHER, extruded: steel, nickel plated; round, approx 1 1/4" OD x 7/8" ID x 3/32" thk o/a; extruded 0.047" h x 1 1/16" OD	Clamp washer for H-1105	N17-T-350014-514	CTT	115508	115508	H-1104	2	-	-	-	-
H-1105	CLAMP: cable; steel; cadmium plated; 2 bolts employed; approx 1 3/16" lg x 1 3/16" wd x 1 1/8" h o/a; holds from 1/4" to 1/2" cable	Clamps W-1101 to O-1101	N17-C-781534-216	CHU	112	151801	H-1105	2	-	-	-	-
H-1106	CLAMP: cable; cellulose plastic; 1 bolt employed; approx 15/16" lg x 1/2" wd x 1/2" h o/a; accom 3/8" cable; 1 mtg hole	Clamps W-1102 to A-1101	N17-C-781108-951	COMMERCIAL PLASTIC CO. CPC742-6	121246		H-1106	2	-	-	-	-

CHANGE 1

8-47



TABLE 8-4. COMBINED PARTS AND SPARE PARTS LIST

SYMBOL DESIG.	NAME OF PART AND DESCRIPTION	FUNCTION	JAN OR NAVY TYPE DESIGNATION	STANDARD NAVY STOCK NUMBER	MANUFACTURERS		TELETYPE PART NO.	ALL SYMBOL DESIGNATIONS INVOLVED	TOTAL NO. PER EQUIP.	SPARE PARTS			
					CODE	DESIG.				EQUIP.		STOCK	
										BOX	QUAN.	BOX	QUAN.
H-1107	SCREW, machine: slot drive; Fil H; iron, nickel plated; #8-32; approx 5/8" lg o/a; 1/2" lg threaded portion; head 1/8" thk x 1/4" diam	Holds H-1106 to A-1101		N17-T-350005-150	CTT	1157	1157	H-1107, H-1139	3	-	-	-	-
H-1108	WASHER, flat: steel, nickel plated; round approx 3/8" OD x 5/32" ID x 1/16" thk o/a	Holds H-1106 to A-1101		N17-T-350013-181	CTT	44048	44048	H-1108, H-1140, H-1149	4	-	-	-	-
H-1109	STUD: steel, nickel plated; approx 3 9/16" lg x 3/8" diam o/a; 1 end threaded approx 7/16" lg w/1/4" - 20 thd; slot on 1 end	Holds SB-154/UG to CY-871/UG or CY-870/UG		N17-T-350013-735	CTT	151437	151437	H-1109	2	-	-	-	-
H-1110	Same as H-366	Holds H-1106 to A-1101											
H-1111	Same as H-513	Holds H-1106 to A-1101											
H-1112	Same as H-543	Holds O-1102 to A-1101											
H-1113	Same as H-118	Holds O-1102 to A-1101											
H-1114	Same as H-125	Holds O-1102 to A-1101											
H-1115	WASHER, flat: steel, nickel plated; round, approx 1/4" OD x 5/32" ID x 0.050" thk o/a	Holds O-1102 to A-1101		N17-T-350009-897	CTT	90789	90789	H-1115, H-1119, H-1164	6	-	-	-	-
H-1116	Same as H-543	Holds O-1103 to A-1101											
H-1117	Same as H-118	Holds O-1103 to A-1101											
H-1118	Same as H-125	Holds O-1103 to A-1101											
H-1119	Same as H-1115	Holds O-1103 to A-1101											
H-1120	Same as H-121	Holds K-1101 to A-1108											
H-1121	Same as H-141	Holds J-1103 to O-1104											
H-1122	Same as H-118	Holds H-1130 to O-1104											
H-1123	Same as H-119	Holds H-1130 to O-1104											
H-1124	Same as H-118	Holds K-1101 to A-1108											
H-1125	Same as H-118	Holds A-1107 to A-1108											
H-1126	Same as H-121	Holds O-1104 to A-1101											
H-1127	Same as H-118	Holds O-1104 to A-1101											

8-48

CHANGE 1

## PARTS LISTS

NAVSHIPS 91393

TT-47/UG, TT-48/UG, TT-69/UG, TT-70/UG

H-1128—H-1147

Section 8

H-1128	Same as H-118	Holds J-1103 to O-1104																		
H-1129	NUT, hexagon: steel, nickel plated; #6-40; 1/16" thk o/a; approx 1/4" across flats	Holds J-1103 to O-1104	N17-T-350007-747	CTT	3606	3606	H-1129, H-1136, H-1141, H-2120	7	1	1	-	-								
H-1130	STUD: steel, nickel plated finish; approx 1 5/32" lg x 1/4" across flats o/a; shank end threaded #6-40 1/4" lg, tap head end #6-40; hex body 1 3/8" lg	Holds E-1101 and TB-1101 to O-1104	N17-T-350013-793	CTT	109110	109110	H-1130	2	-	-	-	-								
H-1131	NUT, hexagon: steel, nickel plated #6-40; approx 3/16" thk o/a; approx 1/4" across flats	Holds H-1134 to TB-1101	N17-T-350013-730	CTT	151416	151416	H-1131, H-1166, H-1179	22	-	-	-	-								
H-1132	Same as H-118	Holds TB-1101 and E-1101 to H-1130																		
H-1133	Same as H-543	Holds TB-1101 and E-1101 to H-1130																		
H-1134	SCREW, machine: slot drive; Fil H; steel, nickel plated; #6-40; approx 3/8" lg o/a; 5/16" lg threaded portion; head 1/16" thk x 1/4" diam	Terminal for W-1101 and holds E-1102 to TB-1101	N17-T-350004-640	CTT	111017	111017	H-1134, H-1172, H-1177	21	-	-	-	-								
H-1136	Same as H-1129	Holds K-1101 to A-1108																		
H-1137	Same as H-125	Holds A-1107 to A-1108																		
H-1138	Same as H-512	Ground for A-1101 on 1 side only																		
H-1139	Same as H-121	Holds A-1108 to A-1101																		
H-1140	Same as H-118	Holds A-1108 to A-1101																		
H-1141	Same as H-1129	Holds A-1108 to A-1101																		
H-1142	WASHER, flat: steel, nickel plated; round, approx 5/16" OD x 3/16" ID x 0.058" thk o/a	Holds E-1103 to A-1104	N17-T-350012-991	CTT	125390	125390	H-1142	1	-	-	-	-								
H-1143	Same as H-796	Holds E-1104 and H-1146 to A-1104																		
H-1144	Same as H-531	Holds E-1104 and H-1106 to A-1104																		
H-1145	Same as H-259	Holds E-1104 and H-1106 to A-1104																		
H-1146	STUD: steel, nickel plated; approx 1 3/8" lg x 1/4" across flats o/a; body end threaded 1/4" lg w/#4-40 thd, shank end threaded 3/8" lg w/#4-40 thd	Mts S-1104, O-1106 and S-1105 to A-1104	N17-T-350013-737	CTT	151440	151440	H-1146	2	-	-	-	-								
H-1147	SCREW, machine: slot drive; Fil H; steel, nickel plated; #8-32; approx 9/16" lg o/a; 7/16" lg threaded portion; head 1/8" thk x 1/4" diam	Holds E-1103 to A-1104	N17-T-350013-144	CTT	1093	1093	H-1147	1	-	-	-	-								

CHANGE 1

8-49

TABLE 8-4. COMBINED PARTS AND SPARE PARTS LIST

SYMBOL DESIG.	NAME OF PART AND DESCRIPTION	FUNCTION	JAN OR NAVY TYPE DESIGNATION	STANDARD NAVY STOCK NUMBER	MANUFACTURERS		TELETYPE PART NO.	ALL SYMBOL DESIGNATIONS INVOLVED	TOTAL NO. PER EQUIP.	SPARE PARTS				
					CODING	DESIG.				EQUIP.		STOCK		
										BOX	QUAN.	BOX	QUAN.	
H-1148	Same as H-366	Holds E-1103 to A-1104												
H-1149	Same as H-1108	Holds E-1103 to A-1104												
H-1150	SCREW, machine: slot drive; Hex H; steel, nickel plated; #6-40; approx 5/16" lg o/a; 1/4" lg threaded portion; head 1/16" thk x 1/4" across flats	Holds A-1104 to A-1105		N17-T-350013-753	CTT	151630	151630	H-1150, H-1333, H-1337, H-1493, H-1500, H-1504, H-1514, H-1515, H-1619, H-1791, H-1818, H-1865, H-1867, H-1883, H-1901, H-1977, H-2016, H-2034, H-2071, H-2073, H-2093, H-2132, H-2143, H-2145	32	1	2	-	-	
H-1151	Same as H-118	Holds A-1104 to A-1105												
H-1152	Same as H-125	Holds A-1104 to A-1105												
H-1153	Same as H-259	Holds S-1104, O-1106 and S-1105 to H-1146												
H-1154	Same as H-531	Holds S-1104, O-1106 and S-1105 to H-1146												
H-1155	Same as H-796	Holds S-1104, O-1106 and S-1105 to H-1146												
H-1156	Same as H-543	Holds A-1105 to A-1101												
H-1157	Same as H-118	Holds A-1105 to A-1101												
H-1158	Same as H-125	Holds A-1105 to A-1101												
H-1159	Same as H-119	Holds H-1165 to A-1105												
H-1160	Same as H-118	Holds H-1165 to A-1105												
H-1161	Same as H-119	Holds R-1101 to A-1105												
H-1162	Same as H-118	Holds R-1101 to A-1105												
H-1163	NUT, hexagon: steel, nickel plated; 5/16" - 32; approx 1/8" thk o/a; 7/16" across flats	Holds O-1112 to A-1105		N17-T-350012-484	CTT	2201	2201	H-1163	2	-	-	-	-	
H-1164	Same as H-1115	Holds A-1105 to A-1101												
H-1165	STUD: steel, nickel plated; approx 3/4" lg x 5/16" across flats o/a; shank end threaded w/3/16" lg - #6-40 thd; c/o body, head, slot, shank; body end tapped w/#6-40 thd	Holds E-1106 and TB-1102 to A-1105		N17-T-350014-539	CTT	150479	150479	H-1165, H-1495, H-1506, H-1510	5	-	-	-	-	



8-52

CHANGE 1

TABLE 8-4. COMBINED PARTS AND SPARE PARTS LIST

SYMBOL DESIG.	NAME OF PART AND DESCRIPTION	FUNCTION	JAN OR NAVY TYPE DESIGNATION	PARTS		TELETYPE PART NO.	ALL SYMBOL DESIGNATIONS INVOLVED	TOTAL NO. PER EQUIP.	SPARE PARTS				
				STANDARD NAVY STOCK NUMBER	MANUFACTURERS				EQUIP.		STOCK		
					CODE				DESIG.	BOX	QUAN.	BOX	QUAN.
H-1307	WASHER, flat: steel, nickel plated; round, approx 1/4" OD x 1/8" ID x 1/16" thk o/a	Spaces O-1310 and A-1302		N17-T-35009-888	CTT	90707	90707	H-1307	1	-	-	-	-
H-1308	SCREW, machine: slot drive; FH; steel, nickel plated; #6-40; approx 11/16" lg o/a; 1/4" lg threaded portion; head 7/32" diam x 1/16" thk	Holds O-1312 to A-1302		N17-T-350014-614	CTT	150040	150040	H-1308, H-1455, H-1730, H-1742, H-1750, H-1775, H-1783, H-1794, H-1808, H-1820, H-1871	13	1	1	-	-
H-1309	Same as H-257	Holds O-1313 to O-1312											
H-1310	Same as H-147	Holds O-1313 to O-1312											
H-1311	Same as H-104	Holds O-1313 to O-1312											
H-1312	WASHER, flat: steel, nickel plated; round, approx 15/32" OD x 1/8" ID x 0.042" thk	Guides O-1315 along A-1324		N17-T-350013-744	CTT	151610	151610	H-1312	1	1	1	-	-
H-1313	Same as H-106	Holds O-1321 to A-1302											
H-1314	Same as H-119	Holds H-1302 to A-1302											
H-1315	Same as H-106	Holds O-1310 to A-1302											
H-1316	SCREW, shoulder: slot drive; FH; steel, nickel plated; #6-40; approx 5/8" lg o/a; 9/32" lg threaded portion; head 15/32" diam x 0.047" thk; shoulder 1/16" lg x 3/16" diam, body 3/16" lg x 1/8" diam	Axle for O-1318 and holds O-1318 and O-1320 to A-1302		N17-T-350014-127	CTT	150063	150063	H-1316	1	1	1	-	-
H-1317	Same as H-118	Holds O-1312 to A-1302											
H-1318	Same as H-119	Holds O-1312 to A-1302											
H-1321	Same as H-220	Holds O-1321 to A-1302											
H-1322	Same as H-118	Holds H-1316 to A-1302											
H-1323	Same as H-119	Holds H-1316 to A-1302											
H-1324	WASHER, flat: steel, nickel plated; round, approx 7/16" OD x 5/32" ID x 1/16" thk o/a	Holds O-1324 to A-1302		N17-T-350013-206	CTT	76461	76461	H-1324, H-1635, H-1960	3	1	1	-	-
H-1325	Same as H-118	Holds O-1324 to A-1302											
H-1326	SCREW, machine: slot drive; FH; steel, nickel plated; #6-40; approx 1/2" lg o/a; thd length approx 7/16"; head approx 1/16" thk x 7/32" diam	Holds O-1324 to A-1302		N17-T-350013-747	CTT	151618	151618	H-1326, H-1348, H-1694, H-1696, H-1711, H-1713, H-1716, H-1903, H-1917, H-2148	14	1	2	-	-

8 Section  
H-1307-H-1326TT-47/UG, TT-48/UG, TT-69/UG, TT-70/UG  
NAVSHIPS 91393

PARTS LISTS

## PARTS LISTS

NAVSHIPS 91393

TT-47/UG, TT-48/UG, TT-69/UG, TT-70/UG

Section 8  
H-1327—H-1357

H-1327	Same as H-199	Retains O-1322 to O-1324																		
H-1328	Same as H-257	Holds O-1328 to A-1303																		
H-1329	Same as H-147	Holds O-1328 to A-1303																		
H-1330	Same as H-516	Holds A-1303 to side frame																		
H-1331	Same as H-118	Holds A-1303 to side frame																		
H-1332	SCREW, machine: slot drive; FH; steel, nickel plated; #3-48; approx 5/16" lg o/a; 1/4" lg threaded portion; head 1/16" thk x 5/32" diam	Holds O-1329 in position	N17-T-350006-892	CTT	42827	42827	H-1332, H-1347	3	-	-	-	-								
H-1333	Same as H-1150	Holds O-1330 to A-1303																		
H-1334	Same as H-118	Holds O-1330 to A-1303																		
H-1335	Same as H-257	Holds O-1331 to O-1330																		
H-1336	Same as H-147	Holds O-1331 to O-1330																		
H-1337	Same as H-1150	Holds O-1330 to A-1304																		
H-1338	Same as H-118	Holds O-1330 to A-1304																		
H-1341	Same as H-257	Holds O-1341 to O-1342																		
H-1342	Same as H-147	Holds O-1341 to O-1342																		
H-1343	Same as H-151	Holds O-1344 to A-1304																		
H-1344	Same as H-147	Holds O-1344 to A-1304																		
H-1345	Same as H-146	Holds O-1343 to A-1305																		
H-1346	Same as H-147	Holds O-1343 to A-1305																		
H-1347	Same as H-1332	Holds O-1345 in position																		
H-1348	Same as H-1326	Holds A-1305 and O-1346 to A-1304																		
H-1349	Same as H-118	Holds A-1305 and O-1346 to A-1304																		
H-1350	Same as H-516	Holds A-1304 to side frame																		
H-1351	Same as H-118	Holds A-1304 to side frame																		
H-1352	Same as H-330	Retains O-1350 to O-1351																		
H-1353	Same as H-151	Holds O-1352 and O-1356 to O-1363																		
H-1354	Same as H-147	Holds O-1352 and O-1356 to O-1363																		
H-1355	Same as H-199	Retains O-1363 to A-1311																		
H-1357	Same as H-330	Retains O-1361 to O-1363																		

CHANGE 1

8-53

TABLE 8-4. COMBINED PARTS AND SPARE PARTS LIST

SYMBOL DESIG.	NAME OF PART AND DESCRIPTION	FUNCTION	JAN OR NAVY TYPE DESIGNATION	STANDARD NAVY STOCK NUMBER	MANUFAC- TURERS		TELETYPE PART NO.	ALL SYMBOL DESIGNATIONS INVOLVED	TOTAL NO. PER EQUIP.	SPARE PARTS			
					CODE	DESIG.				EQUIP.		STOCK	
										BOX	QUAN.	BOX	QUAN.
H-1358	WASHER, flat: steel, nickel plated; round, approx 1/2" OD x 7/32" ID x 0.050" thk o/a	Holds O-1365 to O-1364		N17-T-350013-993	CTT	150323	150323	H-1358, H-1393	2	-	-	-	-
H-1359	Same as H-199	Retains O-1364 through O-1367 and H-1358 to O-1360											
H-1360	Same as H-121	Holds O-1368, O-1369 and O-1402 to A-1311											
H-1361	Same as H-118	Holds O-1368, O-1369 and O-1402 to A-1311											
H-1362	Same as H-121	Holds A-1309 to A-1311											
H-1363	Same as H-118	Holds A-1309 to A-1311											
H-1365	Same as H-201	Holds A-1311 to left side frame											
H-1366	Same as H-118	Holds A-1311 to left side frame											
H-1367	SCREW, machine: slot drive; FH; steel, nickel plated; #6-40; approx 5/8" lg o/a; 9/16" lg threaded portion; head 1/16" thk x 1/4" diam	Holds A-1309 and A-1311 to left side frame		N17-T-350014-925	CTT	151693	151693	H-1367, H-1799, H-1839, H-1924	8	1	2	-	-
H-1368	Same as H-118	Holds A-1309 and A-1311 to left side frame											
H-1370	Same as H-106	Holds O-1373 and O-1374 to A-1311											
H-1371	Same as H-147	Holds O-1373 and O-1374 to A-1311											
H-1374	Same as H-330	Retains O-1374 to A-1311											
H-1375	Same as H-147	Holds O-1376 on O-1374											
H-1376	Same as H-106	Holds O-1376 on O-1374											
H-1377	Same as H-516	Holds O-1377 through O-1379 to right side frame											
H-1378	Same as H-118	Holds O-1377 through O-1379 to right side frame											
H-1379	SCREW, machine: slot drive; Fil H; steel, nickel plated; #4-40; approx 3/16" lg o/a; 1/8" lg threaded portion; head 1/16" thk x 5/32" diam	Holds O-1375 to O-1374		N17-T-350013-120	CTT	1293	1293	H-1379	2	1	1	-	-

8-54

CHANGE 1

## PARTS LISTS

NAVSHIPS 91393

TT-47/UG, TT-48/UG, TT-69/UG, TT-70/UG

Section 8  
H-1380—H-1402

H-1380	Same as H-330	Retains O-1383 on O-1381																		
H-1382	Same as H-118	Holds A-1310 to right side frame																		
H-1383	Same as H-132	Holds A-1310 to right side frame																		
H-1384	Same as H-516	Holds O-1387 to H-1386																		
H-1385	Same as H-118	Holds O-1387 to H-1386																		
H-1386	STUD; steel, nickel plated; c/o shoulder, hex head, slot and body w/slot near end; approx 2 3/16" lg x 1/4" across flats; mts by tapped hole in end of shoulder	Pivot for and mounts A-1307	N17-T-350013-990	CTT	150326	150326	H-1386		1	-	-	-	-	-	-	-	-	-	-	-
H-1387	Same as H-118	Holds O-1386 through O-1389 to right side frame																		
H-1388	Same as H-126	Holds O-1386 through O-1389 to right side frame																		
H-1389	Same as H-151	Holds O-1394 and O-1395 to A-1307																		
H-1390	Same as H-147	Holds O-1394 and O-1395 to A-1307																		
H-1391	Same as H-199	Retains A-1307 on H-1386																		
H-1392	Same as H-330	Retains O-1396 on A-1307																		
H-1393	Same as H-1358	Holds O-1401 to O-1400																		
H-1394	Same as H-199	Retains O-1400, O-1401, O-1403, O-1404 and H-1393 to O-1392																		
H-1395	Same as H-151	Holds O-1417 to O-1418																		
H-1396	Same as H-147	Holds O-1417 to O-1418																		
H-1397	SCREW; machine: slot drive; FH; steel, nickel plated; #3-48; approx 1/2" lg o/a; threaded portion 9/32" lg; head 1/16" thk x 5/32" diam	Holds O-1418 to O-1419	N17-T-350014-213	CTT	150543	150543	H-1397		7	1	2	-	-	-	-	-	-	-	-	-
H-1398	Same as H-773	Clamps W-1301 to O-1418																		
H-1399	Same as H-530	Holds H-1398 to O-1418																		
H-1400	Same as H-147	Holds H-1398 to O-1418																		
H-1401	WASHER, flat: steel round, approx 3/8" OD x 1/8" ID x 0.046" thk o/a	Holds H-1398 to O-1418	N17-T-350013-209	CG	#3514 897	80530	H-1401, H-1944		2	1	1	-	-	-	-	-	-	-	-	-
H-1402	SCREW, machine: slot drive; Hex H; steel, nickel plated; #4-40; approx 27/32" lg o/a; 1/2" lg threaded portion; head 3/16" across flats x 3/32" thk	Adjusts O-1428	N17-T-350010-399	CTT	93507	93507	H-1402		1	-	-	-	-	-	-	-	-	-	-	-

CHANGE 1

8-55



TABLE 8-4. COMBINED PARTS AND SPARE PARTS LIST

PARTS										SPARE PARTS				
SYMBOL DESIG.	NAME OF PART AND DESCRIPTION	FUNCTION	JAN OR NAVY TYPE DESIGNATION	STANDARD NAVY STOCK NUMBER	MANUFACTURERS		TELETYPE PART NO.	ALL SYMBOL DESIGNATIONS INVOLVED	TOTAL NO. PER EQUIP.	EQUIP.		STOCK		
					CODE	DESIG.				BOX	QUAN.	BOX	QUAN.	
H-1403	NUT, hexagon: steel, nickel plated; #4-40; approx 13/32" lg w/3/32" lg threaded portion; 3/16" across flats	Locks O-1402 in position		N17-T-350014-597	CTT	151702	151702	H-1403	1	-	-	-	-	
H-1404	Same as H-387	Holds O-1420 to O-1419												
H-1405	Same as H-106	Holds O-1421 through O-1427 and A-1308 to H-1408												
H-1406	Same as H-147	Holds O-1421 through O-1427 and A-1308 to H-1408												
H-1407	Same as H-104	Holds O-1421 through O-1427 and A-1308 to H-1408												
H-1408	STUD: steel, nickel plated; approx 11/16" lg x 1/4" across flats o/a; shank end #4-40 thd 3/16" lg, body end #6-40 thd 3/16" lg; c/o body, slot, hex head and shank	Mounts O-1421 through O-1427 and A-1308 to O-1418		N17-T-350014-162	CTT	150299	150299	H-1408	2	-	-	-	-	
H-1409	SCREW, machine: wrench drive; Hex H; stainless steel; #6-40; approx 1/4" lg o/a; 3/16" lg threaded portion; head 1/16" thk x 1/4" across flats; character "A" stamped on head	Holds H-1411 to A-1312 and identifies function box arrangement		N17-T-350014-909	CTT	151739A	151739A	H-1409	1	-	-	-	-	
H-1410	Same as H-118	Holds H-1411 to A-1312												
H-1411	HANDLE: steel, nickel plated; "V" formed strip; approx 8 1/2" lg x 1/2" wd x 3/8" h o/a; mts by body hole ea end; 2 tapped holes in 1 side	Handle for function box mech and mounts A-1313		N17-T-350014-211	CTT	150544	150544	H-1411, H-1412	2	-	-	-	-	
H-1412	Same as H-1411	Handle for function box mechanism												
H-1413	Same as H-121	Holds A-1312 to O-1419												
H-1414	Same as H-118	Holds A-1312 to O-1419												
H-1415	Same as H-264	Retains O-1438 to A-1312												
H-1416	Same as H-132	Holds A-1312 to A-1337												
H-1417	Same as H-118	Holds A-1312 to A-1337												
H-1418	Same as H-132	Holds H-1412 to A-1312												
H-1419	Same as H-118	Holds H-1412 to A-1312												
H-1422	Same as H-121	Holds A-1314 to O-1419												
H-1423	Same as H-118	Holds A-1314 to O-1419												



8-58

CHANGE 1

TABLE 8-4. COMBINED PARTS AND SPARE PARTS LIST

SYMBOL DESIG.	NAME OF PART AND DESCRIPTION	FUNCTION	JAN OR NAVY TYPE DESIGNATION	STANDARD NAVY STOCK NUMBER	MANUFAC- TURERS		TELETYPE PART NO.	ALL SYMBOL DESIGNATIONS INVOLVED	TOTAL NO. PER EQUIP.	SPARE PARTS					
					CODE	DESIG.				EQUIP.		STOCK			
										BOX	QUAN.	BOX	QUAN.		
H-1450	Same as H-794	Holds W-1302 to E-1304 or E-1305													
H-1451	WASHER, flat: brass; round, approx 1/4" OD x 1/8" ID x 1/32" thk o/a	Holds W-1302 to E-1304 or E-1305		N17-T-350005-731	TTT	2438	2438	H-1451	1	-	-	-	-	-	-
H-1452	CLAMP: connector, plug; steel, nickel plated; 1 screw, lock washer and washer employed; adjustable from approx 2 3/16" lg to 2 3/4" lg x 1 7/8" wd x 1 5/16" h o/a	Clamps P-1101 to J-1301		N17-T-350014-786	CTT	151810	151810	H-1452	1	-	-	-	-	-	-
H-1453	Same as H-132	Holds H-1452 to right side frame													
H-1454	Same as H-118	Holds H-1452 to right side frame													
H-1455	Same as H-1308	Holds H-1452, O-1962 and O-1965 to right side frame													
H-1456	Same as H-118	Holds H-1452, O-1962 and O-1965 to right side frame													
H-1457	Same as H-104	Holds O-1484 to A-1321													
H-1458	Same as H-147	Holds O-1480, O-1481, A-1320, and E-1308 to A-1321													
H-1464	SCREW, thumb: knurled thumb head; steel, nickel plated; #6-40; 1 1/16" lg o/a; 11/16" lg threaded portion; point 3/32" OD x 3/32" lg w/slot; head 5/8" OD x 5/32" lg; shoulder 5/16" OD x 5/32" lg	Adjusts and holds O-1495 to O-1496		N17-T-350014-538	CTT	150477	150477	H-1464	1	-	-	-	-	-	-
H-1465	SCREW, machine: slot drive; FH; steel, nickel plated; #6-40; approx 3/8" lg o/a; thd portion 1/8" lg; 5/32" diam x 1/8" lg shoulder; slot between shoulder and shank	Holds H-1466 and H-1467 to O-1502		N17-T-350014-351	CTT	150964	150964	H-1465	1	1	1	-	-	-	-
H-1466	WASHER, flat: steel, nickel plated; round, approx 3/8" OD x 5/32" ID x 0.016" thk o/a	Guide for O-1495		N17-T-350013-619	CTT	85762	85762	H-1466	1	-	-	-	-	-	-
H-1467	WASHER, spring: steel; round, approx 3/8" OD x 5/32" ID x 1/16" wd o/a, 0.020" thk material; curved from ctr in 2 places	Applies pressure to H-1466		N17-T-350009-301	CTT	83561	83561	H-1467	1	-	-	-	-	-	-
H-1468	Same as H-257	Holds O-1441 to O-1492													
H-1469	Same as H-147	Holds O-1441 to O-1492													

8 Section  
H-1450—H-1469NAVSHIPS 91393  
TT-47/UG, TT-48/UG, TT-69/UG, TT-70/UG

PARTS LISTS

H-1470	Same as H-257	Holds O-1493 to O-1492																		
H-1471	Same as H-147	Holds O-1493 to O-1492																		
H-1472	Same as H-104	Holds O-1493 to O-1492																		
H-1473	Same as H-330	Retains H-1521, O-1489, O-1495, O-1497, and O-1492 to O-1490																		
H-1474	Same as H-119	Holds O-1526 and O-1496 to O-1486																		
H-1475	Same as H-118	Holds O-1526 and O-1496 to O-1486																		
H-1476	Same as H-302	Holds O-1441 to O-1492																		
H-1477	Same as H-121	Holds O-1496 to H-1509																		
H-1478	Same as H-118	Holds O-1496 to H-1509																		
H-1479	NUT, clamping: steel, nickel plated; #6-40; approx 7/16" lg x 5/16" wd x 0.095" thk o/a; notch in 1 end	Lock nut for H-1464 and guide for O-1495	N17-T- 350014- 349	CTT	150959	150959	H-1479	1	-	-	-	-	-	-	-	-	-	-	-	-
H-1480	Same as H-264	Retains O-1495, O-1496 and H-1479 to H-1464																		
H-1481	WASHER, lock: steel, cadmium plated; round, 1/4" ID x 15/32" OD x 0.025" thk; shakeproof type, straight internal teeth	Holds O-1495 to O-1489 and O-1497	N17-T- 350013- 247	CAXQ	1214	93108	H-1481	1	1	1	-	-	-	-	-	-	-	-	-	-
H-1482	Same as H-290	Holds O-1495 to O-1489 and O-1497																		
H-1483	Same as H-119	Holds O-1510 through O-1513 and O-1515 through O-1520 to H-1487																		
H-1484	WASHER, lock: steel, nickel plated; round, approx 9/32" OD x 1/8" ID x 0.018" thk o/a; shakeproof type, straight internal teeth	Holds O-1510 through O-1513 and O-1515 through O-1520 to H-1487	N17-T- 350010- 25E	CTT	92260	92260	H-1484	1	-	-	-	-	-	-	-	-	-	-	-	-
H-1485	WASHER, flat: steel, round approx 3/16" OD x 1/8" ID x 0.050" thk o/a	Spaces O-1510 through O-1513 and O-1515 through O-1519 or O-1520	N17-T- 350014- 694	CTT	150456	150456	H-1485	9	-	-	-	-	-	-	-	-	-	-	-	-
H-1486	STUD: steel, nickel plated; approx 1 7/16" lg x 5/16" across flats o/a; shank end threaded w/3/16" lg #6-40 thd; c/o hex head, shoulder, body, shank; #6-40 thd tapped hole in head, 7 grooves in body	Guide for O-1521 through O-1525 and mounts O-1526	N17-T- 350014- 260	CTT	150478	150478	H-1486	1	-	-	-	-	-	-	-	-	-	-	-	-
H-1487	STUD: steel, nickel plated; approx 1 3/8" lg x 1/4" across flats o/a; both ends threaded w/#6-40 thd, c/o shank, head and body	Holds O-1510 through O-1513, O-1515 through O-1520 and H-1485 to O-1529	N17-T- 350014- 695	CTT	150457	150457	H-1487	1	-	-	-	-	-	-	-	-	-	-	-	-
H-1488	STUD: steel, nickel plated; approx 1 1/4" lg x 3/16" across flats; shank end threaded w/1/8" lg #4-40 thds, c/o shank, head and body	Locates O-1510 through O-1513 and O-1515 through O-1520	N17-T- 350014- 699	CTT	150462	150462	H-1488	1	-	-	-	-	-	-	-	-	-	-	-	-

CHANGE 1

8-59

8-60

TABLE 8-4. COMBINED PARTS AND SPARE PARTS LIST

PARTS										SPARE PARTS			
SYMBOL DESIG.	NAME OF PART AND DESCRIPTION	FUNCTION	JAN OR NAVY TYPE DESIGNATION	STANDARD NAVY STOCK NUMBER	MANUFAC- TURERS		TELETYPE PART NO.	ALL SYMBOL DESIGNATIONS INVOLVED	TOTAL NO. PER EQUIP.	EQUIP.		STOCK	
					CODE	DESIG.				BOX	QUAN.	BOX	QUAN.
H-1489	Same as H-121	Holds 0-1527 to 0-1529											
H-1490	Same as H-118	Holds 0-1527 to 0-1529											
H-1491	Same as H-125	Holds 0-1527 to 0-1529											
H-1492	Same as H-220	Holds 0-1527 to 0-1529											
H-1493	Same as H-1150	Holds 0-1529 to H-1496											
H-1494	Same as H-118	Holds 0-1529 to H-1496											
H-1495	Same as H-1165	Holds 0-1529 to right side frame											
H-1496	Same as H-118	Holds H-1495 to right side frame											
H-1497	Same as H-119	Holds H-1495 to right side frame											
H-1498	Same as H-147	Holds H-1488 to 0-1529											
H-1499	Same as H-796	Holds H-1488 to 0-1529											
H-1500	Same as H-1150	Holds H-1486 to 0-1529											
H-1501	Same as H-118	Holds H-1486 to 0-1529											
H-1502	Same as H-119	Holds H-1487 to 0-1529											
H-1503	Same as H-118	Holds H-1487 to 0-1529											
H-1504	Same as H-1150	Holds H-1514 to 0-1529											
H-1505	Same as H-118	Holds H-1514 to 0-1529											
H-1506	Same as H-1165	Holds 0-2032 and 0-1529 to right side frame											
H-1507	Same as H-106	Holds H-1518 to 0-1529											
H-1508	Same as H-147	Holds H-1518 to 0-1529											
H-1509	POST: steel, nickel plated; hex shape; approx 1 5/32" lg x 1/4" across flats; mts by tapped hole in ea end	Holds 0-1496 to 0-1529		N17-T- 350013- 888	CTT	150687	150687	H-1509	1	-	-	-	-
H-1510	Same as H-1165	Holds 0-1529 to right side frame											

CHANGE 1

8 Section  
H-1489—H-1510NAVSHIPS 91393  
TT-47/UG, TT-48/UG, TT-69/UG, TT-70/UG

PARTS LISTS

CHANGE 1

H-1511	Same as H-106	Holds O-1518 to O-1529																		
H-1512	Same as H-147	Holds O-1518 to O-1529																		
H-1513	Same as H-118	Holds O-1529 to H-1506																		
H-1514	Same as H-1150	Holds O-1529 to H-1506																		
H-1515	Same as H-1150	Holds H-1510 to right side frame																		
H-1516	Same as H-118	Holds H-1510 to right side frame																		
H-1517	POST, spring: steel, nickel plated; c/o shank, hex head, body; approx 1 1/4" lg x 3/16" across flats o/a; mts by thd shank; 7 grooves in body	Spring post for O-1504	N17-T-350014-543	CTT	150484	150484	H-1517	1	-	-	-	-	-	-	-	-	-	-	-	-
H-1518	POST, spring: steel, nickel plated; head, neck, body, hex shoulder and thd shank; approx 1" lg x 3/16" across flats o/a; mts by 5/32" lg #4-40 threaded shank	Spring post for O-1501	N17-T-350014-352	CTT	150965	150965	H-1518	1	-	-	-	-	-	-	-	-	-	-	-	-
H-1519	Same as H-147	Holds A-1322 to O-1529																		
H-1520	Same as H-257	Holds A-1322 to O-1529																		
H-1521	LATCH, lever: steel, nickel plated; irregular shape, 1 end bent w/spring notch, other end formed; approx 1 3/4" lg x 1 3/8" h x 3/16" wd o/a, 0.050" thk material; mts by ID of hub welded to wd p/o body	Latches selector clutch in stop position through O-1753	N17-T-350014-547	CTT	150489	150489	H-1521	1	1	1	-	-	-	-	-	-	-	-	-	-
H-1522	Same as H-104	Holds A-1322 to O-1529																		
H-1523	Same as H-199	Retains O-1555 to H-1525																		
H-1524	Same as H-199	Retains O-1555 to H-1526																		
H-1525	STUD: steel, piston finish; approx 1/2" lg x 1/4" diam o/a; 1 end threaded 3/16" lg w/#6-40 thd; slot between head and body, drive slot across head	Swivel for and holds O-1555 to O-1541	N17-T-350013-952	CTT	150748	150748	H-1525, H-1526, H-1533 H-1544	6	1	3	-	-	-	-	-	-	-	-	-	-
H-1526	Same as H-1525	Swivel for and holds O-1555 to O-1530																		
H-1527	Same as H-121	Holds O-1531 to O-1541																		
H-1528	Same as H-118	Holds O-1531 to O-1541																		
H-1529	Same as H-125	Holds O-1531 to O-1541																		
H-1530	Same as H-119	Holds H-1526 to O-1530																		
H-1531	Same as H-118	Holds H-1526 to O-1530																		
H-1532	Same as H-199	Retains O-1533 and O-1534 on H-1533																		
H-1533	Same as H-1525	Swivel for and holds O-1534 to O-1541																		

8-61

PARTS LISTS

TT-47/UG, TT-48/UG, TT-69/UG, TT-70/UG

NAVSHIPS 91393

Section 8  
H-1511-H-1533

TABLE 8-4. COMBINED PARTS AND SPARE PARTS LIST

SYMBOL DESIG.	NAME OF PART AND DESCRIPTION	FUNCTION	JAN OR NAVY TYPE DESIGNATION	STANDARD NAVY STOCK NUMBER	MANUFACTURERS		TELETYPE PART NO.	ALL SYMBOL DESIGNATIONS INVOLVED	TOTAL NO. PER EQUIP.	SPARE PARTS					
					CODE	DESIG.				EQUIP.		STOCK			
										BOX	QUAN.	BOX	QUAN.		
H-1534	Same as H-199	Retains O-1534 and O-1561 to O-1559													
H-1535	Same as H-330	Retains O-1540 to O-1541													
H-1536	Same as H-119	Holds H-1533 to O-1541													
H-1537	Same as H-118	Holds H-1533 to O-1541													
H-1538	Same as H-119	Holds H-1525 to O-1541													
H-1539	Same as H-118	Holds H-1525 to O-1541													
H-1540	Same as H-330	Retains O-1544 to O-1541													
H-1541	Same as H-119	Holds H-1544 to O-1541													
H-1542	Same as H-118	Holds H-1544 to O-1541													
H-1543	RING, retainer: steel, nickel plated; "C" shaped w/two internal cutouts; approx 17/32" OD x 7/32" ID x 0.025" thk o/a	Retains O-1542 and O-1545 to O-1541		N17-T-350013-801	WALDINS KOHID	OOOR INC 5133-25	119653	H-1543, H-1596, H-1616 H-1967, H-2022, H-2033	9	1	5	-	-		
H-1544	Same as H-1525	Swivel for and holds O-1550 to O-1541													
H-1545	Same as H-199	Retains O-1548 and O-1550 to O-1541													
H-1546	Same as H-199	Retains O-1550 to O-1558													
H-1547	Same as H-106	Holds O-1550 to O-1662													
H-1548	Same as H-147	Holds O-1550 to O-1662													
H-1549	Same as H-106	Holds H-1555 to O-1554													
H-1550	Same as H-147	Holds H-1555 to O-1554													
H-1551	Same as H-106	Holds O-1534 to O-1662													
H-1552	Same as H-147	Holds O-1534 to O-1662													
H-1553	Same as H-264	Retains O-1563 on H-1554													
H-1554	STUD: steel, nickel plated; approx 3/4" lg x 1/4" across flats o/a; 1 end thd	Stop for O-1564		N17-T-350013-957	CTT	150755	150755	H-1554	1	1	1	-	-		
H-1555	STUD: steel, nickel plated finish; approx 1/2" lg x 3/16" wd across flats; 1 end thd 1/8" lg w/#4-40 thd; hex head w/thd shank 1 side and 3/32" diam plain shank other side	Holds O-1556 and O-1562 to O-1554		N17-T-350013-955	CTT	150752	150752	H-1555	1	1	1	-	-		

8-62

CHANGE 1

## PARTS LISTS

TT-47/UG, TT-48/UG, TT-69/UG, TT-70/UG

NAVSHIPS 91393

H-1556—H-1574

Section 8

H-1556	Same as H-118	Holds O-1554 to O-1564																		
H-1557	Same as H-119	Holds O-1554 to O-1564																		
H-1558	Same as H-141	Holds O-1558 or O-1559 to front plate																		
H-1559	Same as H-118	Holds O-1558 or O-1559 to front plate																		
H-1560	Same as H-125	Holds O-1558 or O-1559 to front plate																		
H-1561	Same as H-141	Holds O-1560 and O-1558 or O-1559 to front plate																		
H-1562	Same as H-118	Holds O-1560 and O-1558 or O-1559 to front plate																		
H-1563	STUD: steel, nickel plated; approx 1 5/32" lg x 3/8" diam o/a; 1 end threaded 1/4" deep w/#10-32 thd; slot around approx ctr and drive slot at end of shank	Pivot for and mounts O-1568, O-1566 and O-1565	N17-T-350014-834	CTT	150175	150175	H-1563	1	-	-	-	-	-	-	-	-	-	-	-	-
H-1564	SCREW, machine: wrench or slot drive; Hex H; steel, nickel plated; #6-40; approx 7/16" lg o/a; 3/16" lg threaded portion; head 1/16" thk x 5/16" across flats; shoulder, 5/32" lg x 7/32" diam; neck between shoulder and threaded portion	Pivot for and holds O-1567 to O-1568	N17-T-350014-595	CTT	151700	151700	H-1564	1	1	1	-	-	-	-	-	-	-	-	-	-
H-1565	Same as H-199	Retains O-1564, O-1565, O-1566 and O-1568 on H-1563																		
H-1566	POST, spring: steel, nickel plated; slotted 1 end, groove near slotted end; approx 1/2" lg x 5/32" diam o/a; mts by 3/32" lg shank w/#6-40 thd	Anchor for O-1650	N17-T-350009-524	CTT	85935	85935	H-1566	1	-	-	-	-	-	-	-	-	-	-	-	-
H-1567	Same as H-119	Holds O-1567 to O-1568																		
H-1568	Same as H-330	Retains O-1574 to O-1570																		
H-1569	WASHER, flat: steel, nickel plated; round, approx 5/16" OD x 3/16" ID x 0.028" thk o/a	Guide for O-1574	N17-T-350013-944	CTT	150711	150711	H-1569, H-1572	4	-	-	-	-	-	-	-	-	-	-	-	-
H-1570	STUD: steel, nickel plated; approx 9/16" lg x 3/16" across flats o/a; 1 end threaded 1/8" lg w/#6-40 thd; other end has slot	Holds O-1574 to front plate	N17-T-350013-941	CTT	150693	150693	H-1570, H-1573	2	1	1	-	-	-	-	-	-	-	-	-	-
H-1571	Same as H-330	Retains O-1577 to H-1573																		
H-1572	Same as H-1569	Guide for O-1577																		
H-1573	Same as H-1570	Holds O-1577 to front plate																		
H-1574	SCREW, machine: slot drive; FH; steel, nickel plated; #4-40; approx 3/8" lg o/a; 5/16" lg threaded portion; head 3/16" diam x 1/16" thk	Holds O-1581 and O-1580 to front plate	N43-S-68788-430	CTT	151685	151685	H-1574, H-1699, H-1825, H-1857, H-1878, H-1928, H-1932, H-2004	1	3	-	-	-	-	-	-	-	-	-	-	-

CHANGE 1

8-63



8-64

TABLE 8-4. COMBINED PARTS AND SPARE PARTS LIST

SYMBOL DESIG.	NAME OF PART AND DESCRIPTION	FUNCTION	JAN OR NAVY TYPE DESIGNATION	STANDARD NAVY STOCK NUMBER	MANUFAC- TURERS		TELETYPE PART NO.	ALL SYMBOL DESIGNATIONS INVOLVED	SPARE PARTS										
					D C O	DESIG.			TOTAL NO. PER EQUIP.	EQUIP.		STOCK							
										BOX	QUAN.	BOX	QUAN.						
H-1575	Same as H-147	Holds O-1581 and O-1580 to front plate																	
H-1576	WASHER, flat; steel, nickel plated; round, approx 1/8" ID x 3/8" OD x 1/32" thk	Holds O-1580 to front plate		N17-T-350005-442	CTT	125802	125802	H-1576	1	1	1	-	-						
H-1577	Same as H-132	Holds O-1582 to front plate																	
H-1578	Same as H-118	Holds O-1582 to front plate																	
H-1579	Same as H-132	Holds O-1593 to O-1595																	
H-1580	Same as H-118	Holds O-1593 to O-1595																	
H-1581	Same as H-125	Holds O-1593 to O-1595																	
H-1582	Same as H-199	Retains O-1593, O-1594 and O-1595 to O-1582																	
H-1583	Same as H-101	Holds O-1597 through O-1599, O-1601 and O-1602 to O-1604																	
H-1584	Same as H-147	Holds O-1597 through O-1599, O-1601 and O-1602 to O-1604																	
H-1585	Same as H-1437	Holds O-1604 to O-1612																	
H-1586	Same as H-147	Holds O-1604 to O-1612																	
H-1587	Same as H-141	Holds A-1323 and O-1614 to front plate																	
H-1588	Same as H-118	Holds A-1323 and O-1614 to front plate																	
H-1589	SCREW, set: slot drive; headless; steel, nickel plated; #10-32; 13/32" lg; cup point	Adjusts air release from O-1609		N17-T-350014-924	CTT	1214	1214	H-1589	1										
H-1590	NUT, hexagon; steel, nickel plated; #10-32; 3/32" thk; 1/4" across flats	Locks H-1589 in position		N17-T-350012-507	CTT	89897	89897	H-1590	1										
H-1591	Same as H-530	Holds O-1605 through O-1608 to O-1589																	
H-1592	Same as H-106	Holds O-1605 through O-1608 to O-1589																	
H-1593	STUD; steel, nickel plated; approx 1 1/2" lg x 1/2" across flats o/a; shank end threaded 3/16" lg w/#10-32 thd, drive slot across other end; 5 slots and 2 grooves irregularly spaced	Guide for O-1589		N17-T-350013-935	CTT	150667	150667	H-1593	1										

CHANGE 1

8 Section  
H-1575—H-1593TT-47/UG, TT-48/UG, TT-69/UG, TT-70/UG  
NAVSHIPS 91393

PARTS LISTS



8-66

CHANGE 1

TABLE 8-4. COMBINED PARTS AND SPARE PARTS LIST

PARTS										SPARE PARTS			
SYMBOL DESIG.	NAME OF PART AND DESCRIPTION	FUNCTION	JAN OR NAVY TYPE DESIGNATION	STANDARD NAVY STOCK NUMBER	MANUFACTURERS		TELETYPE PART NO.	ALL SYMBOL DESIGNATIONS INVOLVED	TOTAL NO. PER EQUIP.	EQUIP.		STOCK	
					CODE	DESIG.				BOX	QUAN.	BOX	QUAN.
H-1619	Same as H-1150	Holds O-1609 to front plate											
H-1620	Same as H-118	Holds O-1609 to front plate											
H-1621	Same as H-119	Holds O-1622 and O-1623 to O-1625											
H-1622	Same as H-118	Holds O-1622 and O-1623 to O-1625											
H-1623	Same as H-119	Holds O-1626 and O-1627 to O-1625											
H-1624	Same as H-118	Holds O-1626 and O-1627 to O-1625											
H-1625	Same as H-516	Holds A-1324 and H-1673 to O-1625											
H-1626	Same as H-118	Holds A-1324 and H-1673 to O-1625											
H-1627	Same as H-125	Holds A-1324 and H-1673 to O-1625											
H-1628	Same as H-121	Holds O-1647 to A-1324											
H-1629	Same as H-121	Holds O-1622 and O-1623 to O-1625											
H-1630	SCREW, machine: slot drive; FH; steel; nickel plated; #6-40; approx 1 5/16" lg o/a; 1 end threaded 1/2" lg; head 1/16" lg x 7/32" diam	Holds A-1324 and O-1631 to front plate		N17-T- 350013- 943	CTT	150710	150710	H-1630, H-1639	2	1	2	-	-
H-1631	Same as H-118	Holds A-1324 and O-1631 to front plate											
H-1632	Same as H-530	Holds O-1632 and O-1633 to A-1324											
H-1633	Same as H-147	Holds O-1632 and O-1633 to A-1324											
H-1634	SCREW, machine: wrench drive; Hex H; steel, steel, nickel plated; #6-40; approx 3/8" lg o/a; threaded portion 7/32" lg; head 3/64" lg x 5/16" across flats; shoulder 1/16" lg x 7/32" diam	Holds O-1629 to O-1625		N17-T- 350014- 328	CTT	150909	150909	H-1634	1	1	1	-	-
H-1635	Same as H-1324	Spaces O-1629 and O-1625											

8 Section  
H-1619—H-1635NAVSHIPS 91393  
TT-47/UG, TT-48/UG, TT-69/UG, TT-70/UG

PARTS LISTS

H-1636	Same as H-119	Holds O-1629 to O-1625
H-1637	Same as H-118	Holds O-1629 to O-1625
H-1638	Same as H-121	Holds O-1663 to A-1324
H-1639	Same as H-1630	Holds A-1324 and O-1636 to front plate
H-1640	Same as H-118	Holds A-1324 and O-1636 to front plate
H-1641	Same as H-516	Holds A-1324 and H-1674 to O-1625
H-1642	Same as H-118	Holds A-1324 and H-1674 to O-1625
H-1643	Same as H-125	Holds A-1324 and H-1674 to O-1625
H-1644	Same as H-121	Holds O-1626 and O-1627 to O-1625
H-1645	Same as H-330	Retains O-1630 to H-1673
H-1646	Same as H-257	Holds A-1326 to O-1646
H-1647	Same as H-147	Holds A-1326 to O-1646
H-1648	Same as H-104	Holds A-1326 to O-1646
H-1649	Same as H-257	Holds A-1325 to O-1646
H-1650	Same as H-147	Holds A-1325 to O-1646
H-1651	Same as H-104	Holds A-1325 to O-1646
H-1652	Same as H-257	Holds O-1643 to O-1646
H-1653	Same as H-147	Holds O-1643 to O-1646
H-1654	Same as H-330	Retains O-1637 to O-1636
H-1655	Same as H-132	Holds O-1647 to front plate
H-1656	Same as H-118	Holds O-1647 to front plate
H-1657	Same as H-257	Holds O-1399 to A-1312
H-1658	Same as H-147	Holds O-1399 to A-1312
H-1659	Same as H-118	Holds O-1327 to O-1324
H-1660	Same as H-132	Holds O-1327 to O-1324
H-1661	Same as H-119	Holds O-1647 to A-1324
H-1662	Same as H-118	Holds O-1647 to A-1324
H-1663	Same as H-330	Retains O-1648 to O-1657

CHANGE 1

8-67

8-68

CHANGE 1

TABLE 8-4. COMBINED PARTS AND SPARE PARTS LIST

SYMBOL DESIG.	NAME OF PART AND DESCRIPTION	FUNCTION	JAN OR NAVY TYPE DESIGNATION	STANDARD NAVY STOCK NUMBER	MANUFAC- TURERS		TELETYPE PART NO.	ALL SYMBOL DESIGNATIONS INVOLVED	TOTAL NO. PER EQUIP.	SPARE PARTS									
					CODE	DESIG.				EQUIP.		STOCK							
										BOX	QUAN.	BOX	QUAN.						
H-1664	Same as H-199	Retains O-1657 to O-1662																	
H-1665	SCREW, machine; wrench drive; square head; steel, nickel plated; #4-40; approx 9/16" lg o/a; 1/8" lg threaded portion; 1/4" sq. x 3/32" thk head	Holds O-1550 to O-1662		N17-T-350014-140	CTT	150219	150219	H-1665, H-1666	2	1	1	-	-						
H-1666	Same as H-1665	Holds O-1534 to O-1662																	
H-1667	Same as H-199	Retains O-1660 to O-1662																	
H-1668	Same as H-330	Retains O-1664 to O-1660																	
H-1669	Same as H-119	Holds O-1663 to A-1324																	
H-1670	Same as H-118	Holds O-1663 to A-1324																	
H-1671	Same as H-118	Holds O-1663 to front plate																	
H-1672	Same as H-132	Holds O-1663 to front plate																	
H-1673	STUD: steel, nickel plated; approx 3/8" across flats x 5/8" lg o/a; 1 end tapped #6-40 1/4" deep; c/o body, hex head, shoulder	Mounts O-1630		N17-T-350014-281	CTT	150800	150800	H-1673, H-1674	2	-	-	-	-						
H-1674	Same as H-1673	Mounts O-1637																	
H-1675	Same as H-118	Holds O-1609 to front plate																	
H-1676	Same as H-121	Holds O-1669 to front plate																	
H-1677	Same as H-330	Retains O-1680 to O-1669																	
H-1678	Same as H-121	Holds O-1680 to O-1664																	
H-1679	Same as H-118	Holds O-1680 to O-1664																	
H-1680	Same as H-125	Holds O-1680 to O-1664																	
H-1681	Same as H-121	Holds O-1680 to O-1648																	
H-1682	Same as H-118	Holds O-1680 to O-1648																	
H-1683	Same as H-125	Holds O-1680 to O-1648																	
H-1684	Same as H-330	Retains O-1680 to O-1675																	
H-1685	Same as H-121	Holds O-1675 to front plate																	
H-1686	Same as H-118	Holds O-1675 to front plate																	
H-1687	Same as H-257	Holds A-1327 to O-1672																	

8 Section  
H-1664-H-1687NAVSHIPS 91393  
TT-47/UG, TT-48/UG, TT-69/UG, TT-70/UG

PARTS LISTS

## PARTS LISTS

NAVSHIPS 91393  
TT-47/UG, TT-48/UG, TT-69/UG, TT-70/UGSection 8  
H-1688—H-1714

H-1688	Same as H-147	Holds A-1327 to O-1672																		
H-1689	Same as H-188	Holds O-1681, O-1682, O-1683, and O-1687 on H-1701																		
H-1690	Same as H-189	Holds O-1681, O-1682, O-1683, and O-1687 on H-1701																		
H-1691	Same as H-151	Holds O-1682 to O-1687																		
H-1692	Same as H-147	Holds O-1682 to O-1687																		
H-1693	Same as H-104	Holds O-1682 to O-1687																		
H-1694	Same as H-1326	Holds O-1684 to O-1687																		
H-1695	Same as H-118	Holds O-1684 to O-1687																		
H-1696	Same as H-1326	Holds W-1384 to O-1687																		
H-1697	Same as H-118	Holds W-1384 to O-1687																		
H-1698	Same as H-125	Holds W-1384 to O-1687																		
H-1699	Same as H-1574	Holds O-1685 to O-1687																		
H-1700	Same as H-147	Holds O-1685 to O-1687																		
H-1701	STUD: steel, nickel plated; approx 1 13/16" lg x 3/8" across flats o/a; both ends threaded w/#10-32 thd, 1 end 7/32" lg, other 1/4" lg; c/o shank, head, neck, body and shank	Swivel for O-1687 and mts O-1681	N17-T- 350014- 142	CTT	150197	150197	H-1701, H-1724	2	1	1	-	-								
H-1702	Same as H-126	Holds O-1688 and O-1689 to O-1693																		
H-1703	Same as H-118	Holds O-1688 and O-1689 to O-1693																		
H-1704	Same as H-126	Holds O-1688 to O-1693																		
H-1705	Same as H-118	Holds O-1688 to O-1693																		
H-1706	Same as H-117	Holds O-1688 and O-1689 to O-1693																		
H-1707	Same as H-117	Holds O-1688 to O-1693																		
H-1708	Same as H-126	Holds O-1689 to O-1693																		
H-1709	Same as H-118	Holds O-1689 to O-1693																		
H-1710	Same as H-117	Holds O-1689 to O-1693																		
H-1711	Same as H-1326	Holds O-1690 to O-1693																		
H-1712	Same as H-118	Holds O-1690 to O-1693																		
H-1713	Same as H-1326	Holds W-1303 to O-1693																		
H-1714	Same as H-118	Holds W-1303 to O-1693																		

CHANGE 1

8-69

8-70

TABLE 8-4. COMBINED PARTS AND SPARE PARTS LIST

SYMBOL DESIG.	NAME OF PART AND DESCRIPTION	FUNCTION	JAN OR NAVY TYPE DESIGNATION	STANDARD NAVY STOCK NUMBER	MANUFACTURERS		TELETYPE PART NO.	ALL SYMBOL DESIGNATIONS INVOLVED	SPARE PARTS										
					CODE	DESIG.			TOTAL NO. PER EQUIP.	EQUIP.		STOCK							
										BOX	QUAN.	BOX	QUAN.						
H-1715	Same as H-125	Holds W-1303 to O-1693																	
H-1716	Same as H-1326	Holds W-1304 to O-1693																	
H-1717	Same as H-118	Holds W-1304 to O-1693																	
H-1718	Same as H-125	Holds W-1304 to O-1693																	
H-1719	Same as H-188	Holds O-1693 on H-1724																	
H-1720	Same as H-189	Holds O-1693 on H-1724																	
H-1721	Same as H-141	Holds O-1694 to O-1693																	
H-1722	Same as H-118	Holds O-1694 to O-1693																	
H-1723	Same as H-117	Holds O-1694 to O-1693																	
H-1724	Same as H-1701	Swivel for and mounts O-1693 to front plate																	
H-1725	Same as H-189	Holds H-1701 to front plate																	
H-1726	Same as H-188	Holds H-1701 to front plate																	
H-1727	Same as H-189	Holds H-1701 to front plate																	
H-1728	Same as H-188	Holds H-1725 to front plate																	
H-1729	Same as H-199	Retains O-1699, O-1700, O-1702 and O-1703 on O-1696																	
H-1730	Same as H-1308	Locks O-1700 to O-1696																	
H-1731	Same as H-118	Locks O-1700 to O-1696																	
H-1732	Same as H-117	Locks O-1700 to O-1696																	
H-1733	Same as H-200	Locks O-1700 to O-1696																	
H-1734	NUT, hexagon; steel, nickel plated; 3/8" - 32; approx 1/8" thk o/a; 1/2" across flats	Locks O-1702 to right side frame		N17-T-350001-357	CTT	2539	2539	H-1734, H-1754, H-1906, H-1916	4	1	1	-	-						
H-1735	WASHER, lock; steel; round, approx 9/16" OD x 3/8" ID x 1/32" thk o/a; split ring type	Locks O-1702 to right side frame		N17-T-350013-195	CTT	73175	73175	H-1735, H-1755, H-1905, H-1915	4	1	2	-	-						
H-1736	Same as H-125	Holds O-1703, O-1702, O-1700, and O-1699 on O-1696																	
H-1737	Same as H-118	Holds O-1703, O-1702, O-1700, and O-1699 on O-1696																	

CHANGE 1

8 Section  
H-1715—H-1737

TT-47/UG, TT-48/UG, TT-69/UG, TT-70/UG

NAVSHIPS 91393

PARTS LISTS

## PARTS LISTS

NAVSHIPS 91393

TT-47/UG, TT-48/UG, TT-69/UG, TT-70/UG

Section 8  
H-1738—H-1763

H-1738	Same as H-119	Holds O-1703, O-1702, O-1700, and O-1699 on O-1696																		
H-1739	SCREW, machine: slot drive; FH; steel, nickel plated; #6-40; approx 1/4" lg o/a; 5/32" lg threaded portion; head 3/32" thk 5/32" diam	Locks O-1708 to O-1706	N17-T-350001-795	CTT	74536	74536	H-1739, H-1756, H-1759	3	1	2	-	-								
H-1740	Same as H-151	Stop adjustment for O-1712																		
H-1741	Same as H-106	Locks H-1740 in position																		
H-1742	Same as H-1308	Locks O-1719 to O-1706																		
H-1743	Same as H-118	Locks O-1719 to O-1706																		
H-1744	Same as H-117	Locks O-1719 to O-1706																		
H-1745	Same as H-200	Locks O-1719 to O-1706																		
H-1746	Same as H-119	Holds O-1720, O-1719, O-1716, O-1712 and O-1713 on O-1706																		
H-1747	Same as H-118	Holds O-1720, O-1719, O-1716, O-1712 and O-1713 on O-1706																		
H-1748	Same as H-125	Holds O-1720, O-1719, O-1716, O-1712 and O-1713 on O-1706																		
H-1749	Same as H-199	Retains O-1738 and O-1735 on O-1706																		
H-1750	Same as H-1308	Locks O-1737 to O-1706																		
H-1751	Same as H-117	Locks O-1737 to O-1706																		
H-1752	Same as H-118	Locks O-1737 to O-1706																		
H-1753	Same as H-200	Locks O-1737 to O-1706																		
H-1754	Same as H-1734	Locks O-1734 to left side frame																		
H-1755	Same as H-1735	Locks O-1734 to left side frame																		
H-1756	Same as H-1739	Locks O-1732 to O-1706																		
H-1757	Same as H-151	Stop adjustment for O-1724																		
H-1758	Same as H-106	Locks H-1757 in position																		
H-1759	Same as H-1739	Locks O-1723 to O-1706																		
H-1760	Same as H-268	Locks O-1745 to H-1755																		
H-1761	Same as H-118	Locks O-1745 to H-1755																		
H-1762	Same as H-302	Holds O-1751 to O-1753																		
H-1763	Same as H-147	Holds O-1751 to O-1753																		

CHANGE 1

8-71



TABLE 8-4. COMBINED PARTS AND SPARE PARTS LIST

SYMBOL DESIG.	NAME OF PART AND DESCRIPTION	FUNCTION	JAN OR NAVY TYPE DESIGNATION	STANDARD NAVY STOCK NUMBER	MANUFACTURERS		TELETYPE PART NO.	ALL SYMBOL DESIGNATIONS INVOLVED	TOTAL NO. PER EQUIP.	SPARE PARTS									
					CODE	DESIG.				EQUIP.		STOCK							
										BOX	QUAN.	BOX	QUAN.						
H-1764	Same as H-300	Holds O-1751 to O-1753																	
H-1765	Same as H-300	Holds O-1753 to O-1754																	
H-1766	Same as H-147	Holds O-1753 to O-1754																	
H-1767	Same as H-119	Holds O-1741 through O-1743 to O-1720																	
H-1768	SCREW, shoulder: slot drive: FH; steel, nickel plated; #6-4C; approx 15/32" lg o/a; 1/4" lg threaded portion; head 9/32" diam x 3/32" thk; shoulder 3/16" diam x 1/8" thk; neck between head and shoulder	Holds O-1741 through O-1743 to O-1720		N17-T- 350005- 771	CTT	6800	6800	H-1768	1	-	-	-	-	-	-	-	-	-	-
H-1769	Same as H-302	Holds O-1753 to O-1754																	
H-1770	RING, retainer: steel, nickel plated; approx 13/16" OD x 11/32" free diam x 0.035" thk o/a; mts by cutout section 1 side	Retains O-1756 on O-1755		N17-T- 350013- 908	CTT	119655	119655	H-1770	1	-	-	-	-	-	-	-	-	-	-
H-1771	WASHER, flat: steel, nickel plated; round, approx 21/32" OD x 3/8" ID x 0.042" thk o/a	Spaces H-1770 and H-1772		N17-T- 350013- 758	CTT	151639	151639	H-1771	1	-	-	-	-	-	-	-	-	-	-
H-1772	WASHER, spring: steel, nickel plated; round, approx 17/32" OD x 3/8" ID x 1/16" formed width o/a, 0.010" thk material	Applies pressure to O-1756		N17-T- 350013- 757	CTT	151638	151638	H-1772	1	-	-	-	-	-	-	-	-	-	-
H-1773	Same as H-516	Holds O-1757 and A-1330 to right side frame																	
H-1774	Same as H-118	Holds O-1757 and A-1330 to right side frame																	
H-1775	Same as H-1308	Locks O-1758 to O-1755																	
H-1776	Same as H-118	Locks O-1758 to O-1755																	
H-1777	Same as H-302	Holds O-1764 to O-1765																	
H-1778	Same as H-147	Holds O-1764 to O-1765																	
H-1779	Same as H-300	Holds O-1764 to O-1765																	
H-1780	Same as H-101	Holds O-1766 through O-1772 to O-1765																	
H-1781	Same as H-147	Holds O-1766 through O-1772 to O-1765																	
H-1782	Same as H-302	Holds O-1766 through O-1772 to O-1765																	

8-72

CHANGE 1



8-74

CHANGE 1

TABLE 8-4. COMBINED PARTS AND SPARE PARTS LIST

PARTS										SPARE PARTS			
SYMBOL DESIG.	NAME OF PART AND DESCRIPTION	FUNCTION	JAN OR NAVY TYPE DESIGNATION	STANDARD NAVY STOCK NUMBER	MANUFACTURERS		TELETYPE PART NO.	ALL SYMBOL DESIGNATIONS INVOLVED	TOTAL NO. PER EQUIP.	EQUIP.		STOCK	
					CODE	DESIG.				BOX	QUAN.	BOX	QUAN.
H-1809	Same as H-118	Locks O-1813 to O-1755											
H-1810	Same as H-300	Holds O-1824 to O-1825											
H-1811	Same as H-147	Holds O-1824 to O-1825											
H-1812	Same as H-302	Holds O-1824 to O-1825											
H-1813	Same as H-101	Holds O-1826 through O-1828 and H-1837 to O-1825											
H-1814	Same as H-147	Holds O-1826 through O-1828 and H-1837 to O-1825											
H-1815	Same as H-1803	Holds O-1826 through O-1828 and H-1837 to O-1825											
H-1816	Same as H-113	Locks O-1829 to O-1755											
H-1817	Same as H-147	Locks O-1829 to O-1755											
H-1818	Same as H-1150	Holds H-1838 to left side frame											
H-1819	Same as H-118	Holds H-1838 to left side frame											
H-1820	Same as H-1308	Locks O-1830 to O-1755											
H-1821	Same as H-118	Locks O-1830 to O-1755											
H-1822	Same as H-300	Holds O-1837 to O-1839											
H-1823	Same as H-147	Holds O-1837 to O-1839											
H-1824	Same as H-302	Holds O-1837 to O-1839											
H-1825	Same as H-1574	Holds O-1839 to O-1840											
H-1826	Same as H-147	Holds O-1839 to O-1840											
H-1827	Same as H-146	Holds O-1841 to O-1840											
H-1828	Same as H-147	Holds O-1841 to O-1840											
H-1832	STUD, eccentric; steel, nickel plated; approx 11/16" lg x 5/16" across flats o/a; shank threaded 3/16" lg w/#6-40 thd; slot next to hex shoulder, drive slot across end of body	Swivel for and mounts 1 end of O-1842 to O-2009		N17-T- 350014- 640	CTT	150364	150364	H-1832	1	-	-	-	-
H-1833	Same as H-118	Holds H-1832 to O-2009											

8 Section  
H-1809—H-1833

TT-47/UG, TT-48/UG, TT-69/UG, TT-70/UG

NAVSHIPS 91393

PARTS LISTS



8-76

TABLE 8-4. COMBINED PARTS AND SPARE PARTS LIST

SYMBOL DESIG.	NAME OF PART AND DESCRIPTION	FUNCTION	JAN OR NAVY TYPE DESIGNATION	STANDARD NAVY STOCK NUMBER	MANUFAC- TURERS		TELETYPE PART NO.	ALL SYMBOL DESIGNATIONS INVOLVED	SPARE PARTS										
					CODE	DESIG.			TOTAL NO. PER EQUIP.	EQUIP.		STOCK							
										BOX	QUAN.	BOX	QUAN.						
H-1857	Same as H-1574	Holds O-1909 through O-1913 to O-1848																	
H-1858	NUT, shoulder: stainless steel; #4-40; approx 5/32" thk o/a; 1/4" across flats; c/o hex head, body and shank	Locks O-1858 to O-1857		N17-T-350014-121	CTT	150078	150078	H-1858	1	1	1	-	-						
H-1859	Same as H-104	Holds O-1853 and O-1855 to O-1857																	
H-1860	Same as H-147	Holds O-1853 and O-1855 to O-1857																	
H-1861	Same as H-146	Holds O-1853 and O-1855 to O-1857																	
H-1862	Same as H-104	Holds O-1855 to O-1857																	
H-1863	Same as H-147	Holds O-1855 to O-1857																	
H-1864	SCREW, machine: wrench drive; Hex H; stainless steel; #4-40; approx 1/4" lg o/a; 3/16" lg threaded portion; head 1/16" thk x 3/16" across flats; character "N" stamped on head	Holds O-1855 to O-1857 and identifies type box arrangement		N17-T-350014-910	CTT	151738N	151738N	H-1864	1	-	-	-	-						
H-1865	Same as H-1150	Holds A-1329 to O-1914																	
H-1866	Same as H-119	Holds A-1329 to O-1914																	
H-1867	Same as H-1150	Holds A-1329 to O-1995																	
H-1868	SCREW, shoulder: slot drive; Hex H; steel, nickel plated; #6-40; approx 19/32" lg o/a; 1/4" lg threaded portion; head 1/16" thk x 5/16" across flats; shoulder 3/32" lg x 5/32" diam	Holds O-1919 and O-1915 to right side frame		N17-T-350014-659	CTT	150395	150395	H-1868, H-1971	2	1	1	-	-						
H-1869	Same as H-118	Holds O-1919 and O-1915 to right side frame																	
H-1870	Same as H-119	Holds O-1919 and O-1915 to right side frame																	
H-1871	Same as H-1308	Holds O-1917, O-1918 and O-1920 to right side frame																	
H-1872	Same as H-118	Holds O-1917, O-1918 and O-1920 to right side frame																	
H-1873	Same as H-119	Holds O-1917, O-1918 and O-1920 to right side frame																	
H-1874	Same as H-199	Retains O-1921 to A-1307																	
H-1875	Same as H-330	Retains O-1914 to O-1930																	

CHANGE 1

8 Section  
H-1857-H-1875NAVSHIPS 91393  
TT-47/UG, TT-48/UG, TT-69/UG, TT-70/UG

PARTS LISTS

## PARTS LISTS

TT-47/UG, TT-48/UG, TT-69/UG, TT-70/UG

NAVSHIPS 91393

Section 8  
H-1876-H-1898

H-1876	Same as H-199	Retains O-1921 to O-1930																		
H-1877	Same as H-199	Retains O-1928 to O-1930																		
H-1878	Same as H-1574	Holds O-1922 to O-1933																		
H-1879	Same as H-147	Holds O-1922 to O-1930																		
H-1880	Same as H-104	Holds O-1922 to O-1930																		
H-1881	WASHER, flat: steel, nickel plated; round approx 5/16" OD x 1/8" ID x 0.058" thk o/a	Spaces O-1922 and O-1930	N17-T-350014-667	CTT	150411	150411	H-1881		2	-	-	-	-	-	-	-	-	-	-	-
H-1882	Same as H-118	Holds O-1935 to right side frame																		
H-1883	Same as H-1150	Holds O-1935 to right side frame																		
H-1884	Same as H-119	Holds H-1886 to O-1925																		
H-1885	Same as H-118	Holds H-1886 to O-1925																		
H-1886	STUD, eccentric: steel, nickel plated; approx 9/16" lg x 5/16" across flats o/a; shank end threaded w/3/16" lg #6-40 thd; c/o shank, hex head and body w/slot near end	Pivot for O-1928	N17-T-350014-676	CTT	150429	150429	H-1886, H-1985		2	1	1	-	-	-	-	-	-	-	-	-
H-1887	Same as H-199	Retains O-1928 on H-1886																		
H-1888	SCREW, machine: slot drive; Hex H; steel, nickel plated; #6-40; approx 7/16" o/a; 3/8" lg threaded portion; head 1/16" thk x 1/4" across flats	Holds O-1925 to O-2017	N17-T-350013-755	CTT	151632	151632	H-1888, H-1910, H-2001, H-2014		7	-	-	-	-	-	-	-	-	-	-	-
H-1889	Same as H-118	Holds O-1925 to O-2017																		
H-1890	Same as H-125	Holds O-1925 to O-2017																		
H-1891	Same as H-141	Holds O-1926 and O-1931 to O-1930																		
H-1892	Same as H-125	Holds O-1926 and O-1931 to O-1930																		
H-1893	Same as H-118	Holds O-1926 and O-1931 to O-1930																		
H-1894	Same as H-119	Holds O-1926 and O-1931 to O-1930																		
H-1895	Same as H-199	Retains O-1930 on H-1896																		
H-1896	STUD: steel, nickel plated; approx 3/4" lg x 5/16" across flats o/a; shank end threaded 3/16" lg w/#10-32 thd; c/o shank, Hex H and body w/2 slots	Pivot for O-1930	N17-T-350014-652	CTT	150380	150380	H-1896		1	1	1	-	-	-	-	-	-	-	-	-
H-1897	Same as H-189	Holds H-1896 to right side frame																		
H-1898	Same as H-188	Holds H-1896 to right side frame																		

CHANGE 1

8-77

8-78

TABLE 8-4. COMBINED PARTS AND SPARE PARTS LIST

SYMBOL DESIG.	NAME OF PART AND DESCRIPTION	FUNCTION	JAN OR NAVY TYPE DESIGNATION	STANDARD NAVY STOCK NUMBER	MANUFACTURERS		TELETYPE PART NO.	ALL SYMBOL DESIGNATIONS INVOLVED	SPARE PARTS										
					CODE	DESIG.			TOTAL NO. PER EQUIP.	EQUIP.		STOCK							
										BOX	QUAN.	BOX	QUAN.						
H-1899	Same as H-121	Holds O-1936 to right side frame																	
H-1900	Same as H-118	Holds O-1936 to right side frame																	
H-1901	Same as H-1150	Holds A-1330 to right side frame																	
H-1902	Same as H-118	Holds A-1330 to right side frame																	
H-1903	Same as H-1326	Holds O-1943 to O-1940																	
H-1904	Same as H-118	Holds O-1943 to O-1940																	
H-1905	Same as H-1735	Holds O-1954 to right side frame																	
H-1906	Same as H-1734	Holds O-1954 to right side frame																	
H-1907	STUD; steel, nickel plated; approx 1/2" lg x 3/16" diam o/a; 1 end threaded 1/4" lg w/#6-40 thd; c/o head w/slot, slot and threaded body	Holds O-1790 to O-1942		N17-T-350014-129	CTT	150055	150055	H-1907, H-2154	2	1	2	-	-						
H-1908	Same as H-118	Holds O-1790 to O-1942																	
H-1909	Same as H-119	Holds O-1790 to O-1942																	
H-1910	Same as H-1888	Holds O-1942 to O-1940																	
H-1911	Same as H-118	Holds O-1942 to O-1940																	
H-1912	SCREW, shoulder: slot drive; FH; steel, nickel plated; #6-40; approx 7/16" lg o/a; approx 9/32" lg threaded portion incl slot; head 3/32" thk x 1/4" diam; shoulder 1/16" lg x 3/16" diam	Holds O-1950 and O-1953 to O-1948		N17-T-350013-106	CTT	1196	1196	H-1912, H-1919	2	1	1	-	-						
H-1913	Same as H-118	Holds O-1950 and O-1953 to O-1948																	
H-1914	Same as H-119	Holds O-1950 and O-1953 to O-1948																	
H-1915	Same as H-1735	Holds O-1955 to left side frame																	
H-1916	Same as H-1734	Holds O-1955 to left side frame																	
H-1917	Same as H-1326	Holds O-1946 to O-1940																	
H-1918	Same as H-118	Holds O-1946 to O-1940																	

CHANGE 1

8 Section  
H-1899—H-1918NAVSHIPS 91393  
TT-47/UG, TT-48/UG, TT-69/UG, TT-70/UG

PARTS LISTS

H-1919	Same as H-1912	Holds O-1953 and O-1949 to O-1947
H-1920	Same as H-118	Holds O-1953 and O-1949 to O-1947
H-1921	Same as H-119	Holds O-1953 and O-1949 to O-1947
H-1922	Same as H-1601	Holds O-1960 to right side frame
H-1923	Same as H-189	Holds O-1960 to right side frame
H-1924	Same as H-1367	Holds O-1962, O-1964, and O-1965 to right side frame
H-1925	Same as H-118	Holds O-1962, O-1964, and O-1965 to right side frame
H-1926	Same as H-121	Holds O-1944 to right side frame
H-1927	Same as H-118	Holds O-1944 to right side frame
H-1928	Same as H-1574	Holds O-1957 to O-1944
H-1929	Same as H-147	Holds O-1957 to O-1944
H-1930	Same as H-121	Holds O-1945 to left side frame
H-1931	Same as H-118	Holds O-1945 to left side frame
H-1932	Same as H-1574	Holds O-1958 to O-1945
H-1933	Same as H-147	Holds O-1958 to O-1945
H-1934	Same as H-268	Holds O-1967, O-1969 and O-1970 to left side frame
H-1935	Same as H-118	Holds O-1967, O-1969 and O-1970 to left side frame
H-1936	Same as H-1601	Holds O-1960 to left side frame
H-1937	Same as H-189	Holds O-1960 to left side frame
H-1938	Same as H-126	Holds O-1962 to right side frame
H-1939	Same as H-118	Holds O-1962 to right side frame
H-1940	Same as H-126	Holds O-1967 to left side frame

CHANGE 1

8-79



TABLE 8-4. COMBINED PARTS AND SPARE PARTS LIST

PARTS										SPARE PARTS			
SYMBOL DESIG.	NAME OF PART AND DESCRIPTION	FUNCTION	JAN OR NAVY TYPE DESIGNATION	STANDARD NAVY STOCK NUMBER	MANUFAC- TURERS		TELETYPE PART NO.	ALL SYMBOL DESIGNATIONS INVOLVED	TOTAL NO. PER EQUIP.	EQUIP.		STOCK	
					CODE	DESIG.				BOX	QUAN.	BOX	QUAN.
H-1941	Same as H-118	Holds O-1967 to left side frame											
H-1942	Same as H-151	Holds H-1944, H-1955 and O-1974 to right side frame											
H-1943	Same as H-147	Holds H-1944, H-1955 and O-1974 to right side frame											
H-1944	Same as H-1401	Guide for and holds O-2065 in position											
H-1945	Same as H-104	Stop for O-2065											
H-1946	Same as H-257	Holds O-1794 to right side frame											
H-1947	Same as H-147	Holds O-1794 to right side frame											
H-1948	Same as H-126	Holds O-1978 and O-1977 to O-1972											
H-1949	Same as H-118	Holds O-1978 and O-1977 to O-1972											
H-1950	Same as H-126	Holds O-1980 to O-1972											
H-1951	Same as H-118	Holds O-1980 to O-1972											
H-1952	Same as H-119	Holds O-1976 and O-1981 through O-1983 to left side frame											
H-1953	Same as H-118	Holds O-1976 and H-1981 through O-1983 to left side frame											
H-1954	STUD: steel, nickel plated; approx 1 1/4" lg x 1/4" diam o/a; shank end #6-40 thd approx 5/16" lg; c/o slotted head, body and shank	Pivot for and holds O-1982 and O-1983 to left side frame		N17-T-350014-330	CTT	150912	150912	H-1954	1	-	-	-	-
H-1955	Same as H-374	Holds O-1982 to O-1983											
H-1956	Same as H-147	Holds O-1982 to O-1983											
H-1957	Same as H-257	Holds O-1984 to left side frame											
H-1958	Same as H-147	Holds O-1984 to left side frame											

CHANGE 1

## PARTS LISTS

NAVSHIPS 91393  
TT-47/UG, TT-48/UG, TT-69/UG, TT-70/UGSection 8  
H-1959-H-1976

H-1959	SCREW, shoulder: slot drive; Hex H; steel, nickel plated #6-40; approx 15/32" lg o/a; 5/32" lg threaded portion; head 3/32" thk x 5/16" across flats; shoulder 1/16" lg x 7/32" diam	Pivot for and holds O-1985 to left side frame	N17-T-350014-626	CTT	150342	150342	H-1959	1	1	1	-	-
H-1960	Same as H-1324	Spaces O-1985 from left side frame										
H-1961	Same as H-118	Holds O-1985 to left side frame										
H-1962	Same as H-119	Holds O-1985 to left side frame										
H-1963	SCREW, shoulder: slot drive; FH; steel, nickel plated; #6-40; approx 1/4" lg o/a; threaded portion 1/8" lg; head 1/16" lg x 5/16" diam; shoulder 1/16" lg x 3/16" diam	Pivot for and holds O-1986 to left side frame	N17-T-350014-190	CTT	150646	150646	H-1963	1	1	1	-	-
H-1964	Same as H-121	Holds H-1966 to left side frame										
H-1965	Same as H-118	Holds H-1966 to left side frame										
H-1966	STUD: slot drive; steel, nickel plated; hex head w/tapped hole, body has slot across end, and near end; approx 13/16" lg x 5/16" across flats o/a; mts by tapped hole	Pivot for O-1993	N17-T-350013-996	CTT	150318	150318	H-1966	1	-	-	-	-
H-1967	Same as H-1543	Retains O-1988 through O-1994 on H-1966										
H-1968	SCREW, machine: slot drive; FH; steel, nickel plated; #4-40; approx 3/8" lg o/a; threaded portion 1/4" lg; head 1/16" lg x 5/32" diam	Holds O-1988 through O-1993 and H-1998 to O-1994	N17-T-350013-929	CTT	150652	150652	H-1968	2	1	2	-	-
H-1969	Same as H-147	Holds O-1988 through O-1993 and H-1988 to O-1994										
H-1970	Same as H-119	Holds A-1329 to O-1995										
H-1971	Same as H-1868	Holds O-1998 and O-1996 to left side frame										
H-1972	Same as H-118	Holds O-1998 and O-1996 to left side frame										
H-1973	Same as H-119	Holds O-1998 and O-1996 to left side frame										
H-1974	Same as H-201	Holds O-1996, O-1999 and O-2000 to left side frame										
H-1975	Same as H-118	Holds O-1996, O-1999 and O-2000 to left side frame										
H-1976	Same as H-119	Holds O-1996, O-1999 and O-2000 to left side frame										

CHANGE 1

8-81

8-82

CHANGE 1

TABLE 8-4. COMBINED PARTS AND SPARE PARTS LIST

SYMBOL DESIG.	NAME OF PART AND DESCRIPTION	FUNCTION	JAN OR NAVY TYPE DESIGNATION	STANDARD NAVY STOCK NUMBER	MANUFACTURERS		TELETYPE PART NO.	ALL SYMBOL DESIGNATIONS INVOLVED	TOTAL NO. PER EQUIP.	SPARE PARTS				
					CODE	DESIG.				EQUIP.		STOCK		
										BOX	QUAN.	BOX	QUAN.	
H-1977	Same as H-1150	Holds H-1979 and H-1980 to left side frame												
H-1978	Same as H-118	Holds H-1979 and H-1980 to left side frame												
H-1979	CLAMP: steel; nickel plated; approx 3/4" lg x 1 1/16" h x 1/8" wd o/a; bent in ctr w/2 rounded cutouts irregularly placed in ctr of side opposite mtg holes	Retains O-2014 to left side frame		N17-T-350014-664	CTT	150401	150401	H-1979	1	-	-	-	-	-
H-1980	CLAMP: steel; nickel plated; approx 3/4" lg x 2 1/32" h x 5/32" wd o/a, material 0.035" thk, mts by 2 body holes; irregularly formed near ctr, rounded cutout in ctr of 1 side	Retains O-2014 to left side frame		N17-T-350014-665	CTT	150402	150402	H-1980	1	-	-	-	-	-
H-1981	Same as H-330	Retains O-2004 to O-1995												
H-1982	Same as H-199	Retains O-2003 to O-2004												
H-1983	Same as H-199	Retains O-2005 to O-2004												
H-1984	Same as H-199	Retains O-2003 to H-1985												
H-1985	Same as H-1886	Pivot for O-2003												
H-1986	Same as H-118	Holds H-1985 to O-2009												
H-1987	Same as H-119	Holds H-1985 to O-2009												
H-1988	WASHER, flat: steel, nickel plated; oblong, approx 7/8" wd x 1" lg x 5/16" ID o/a, 0.030" thk material; has hole on 2 sides of ID	Spaces and retains O-1990 and O-1992		N17-T-350014-227	CTT	150649	150649	H-1988	1	-	-	-	-	-
H-1989	Same as H-151	Holds O-2013 to O-2010												
H-1990	Same as H-147	Holds O-2013 to O-2010												
H-1991	Same as H-104	Holds O-2013 to O-2010												
H-1992	STUD: steel, nickel plated; approx 5/8" lg x 5/16" across flats o/a; shank end threaded 3/16" lg w/#10-32 thd; c/o shank, Hex H and body w/2 slots	Pivot for O-2004		N17-T-350014-666	CTT	150410	150410	H-1992	1	1	1	-	-	-
H-1993	Same as H-199	Retains O-2004 on H-1992												
H-1994	Same as H-141	Holds O-2008 and O-2007 to O-2004												
H-1995	Same as H-125	Holds O-2008 and O-2007 to O-2004												

8 Section  
H-1977—H-1995TT-47/UG, TT-48/UG, TT-69/UG, TT-70/UG  
NAVSHIPS 91393

PARTS LISTS

CHANGE 1

8-83

H-1996	Same as H-118	Holds 0-2008 and 0-2007 to 0-2004												
H-1997	Same as H-119	Holds 0-2008 and 0-2007 to 0-2004												
H-1998	Same as H-199	Holds 0-2012 to 0-2010												
H-1999	Same as H-189	Holds H-1992 to left side frame												
H-2000	Same as H-188	Holds H-1992 to left side frame												
H-2001	Same as H-1888	Holds 0-2009 to 0-2017												
H-2002	Same as H-118	Holds 0-2009 to 0-2017												
H-2003	Same as H-125	Holds 0-2009 to 0-2017												
H-2004	Same as H-1574	Holds 0-2018 to 0-2017												
H-2005	Same as H-147	Holds 0-2018 to 0-2017												
H-2006	Same as H-104	Holds 0-2018 to 0-2017												
H-2007	Same as H-201	Holds 0-1530 to 0-2017												
H-2008	Same as H-118	Holds 0-1530 to 0-2017												
H-2009	Same as H-121	Holds 0-2025 to right side frame												
H-2010	Same as H-118	Holds 0-2025 to right side frame												
H-2011	STUD: steel, approx 3/8" lg x 3/16" diam o/a; #6-40 thd 5/32" lg on shank end; slot drive	Pivot for and mounts 0-2021 to right side frame	N17-T-350014-274	CTT	150781	150781	H-2011, H-2051	2	-	-	-	-	-	-
H-2012	Same as H-118	Holds H-2011 to right side frame												
H-2013	Same as H-119	Holds H-2011 to right side frame												
H-2014	Same as H-1888	Holds 0-2050 to right side frame												
H-2015	Same as H-118	Holds 0-2050 to right side frame												
H-2016	Same as H-1150	Holds 0-2032 to right side frame												
H-2017	Same as H-118	Holds 0-2032 to right side frame												
H-2018	STUD: steel; approx 17/32" lg x 5/32" diam o/a; 1 end threaded 3/16" lg w/#4-40 thd	Spring post for right side of 0-2021	N17-T-350001-296	CTT	125696	125696	H-2018, H-2048	2	-	-	-	-	-	-

PARTS LISTS

TT-47/UG, TT-48/UG, TT-69/UG, TT-70/UG

NAVSHIPS 91393

Section 8  
H-1996-H-2018

8-84

CHANGE 1

TABLE 8-4. COMBINED PARTS AND SPARE PARTS LIST

PARTS										SPARE PARTS			
SYMBOL DESIG.	NAME OF PART AND DESCRIPTION	FUNCTION	JAN OR NAVY TYPE DESIGNATION	STANDARD NAVY STOCK NUMBER	MANUFAC- TURERS		TELETYPE PART NO.	ALL SYMBOL DESIGNATIONS INVOLVED	TOTAL NO. PER EQUIP.	EQUIP.		STOCK	
					CODE	DESIG.				BOX	QUAN.	BOX	QUAN.
H-2019	Same as H-147	Holds H-2018 to O-2021											
H-2020	Same as H-796	Holds H-2018 to O-2021											
H-2021	Same as H-199	Retains O-2026 to H-2023											
H-2022	Same as H-1543	Retains O-2030 on A-1331											
H-2023	STUD: steel, nickel plated; approx 1 3/4" lg x 5/16" across flats o/a; 1 end thd w/#6-40 thd, c/o shank, head, shoulder, and body; 3 grooves in body	Pivot for and mounts O-2026 to A-1331		N17-T-350014-134	CTT	150214	150214	H-2023	1	-	-	-	-
H-2024	Same as H-121	Holds O-2032 to O-2025											
H-2025	Same as H-118	Holds O-2032 to O-2025											
H-2026	Same as H-121	Holds A-1331 to O-2025											
H-2027	Same as H-118	Holds A-1331 to O-2025											
H-2028	Same as H-119	Holds H-2023 to A-1331											
H-2029	Same as H-118	Holds H-2023 to A-1331											
H-2030	Same as H-121	Holds A-1332 to O-2025											
H-2031	Same as H-118	Holds A-1332 to O-2025											
H-2032	Same as H-322	Retains H-2056 and O-2024 to A-1331											
H-2033	Same as H-1543	Retains O-2046 and O-2048 on O-2050											
H-2034	Same as H-1150	Holds O-2046 to O-2048											
H-2035	Same as H-118	Holds O-2046 to O-2048											
H-2036	Same as H-125	Holds O-2046 to O-2048											
H-2037	Same as H-199	Retains O-2005 to A-1306											
H-2038	Same as H-121	Holds O-2050 to A-1331											
H-2039	Same as H-118	Holds O-2050 to A-1331											
H-2040	Same as H-199	Retains O-2033 on A-1332											
H-2041	Same as H-330	Retains O-2043 on A-1332											
H-2042	Same as H-132	Holds A-1333 to left side frame											

8 Section  
H-2019—H-2042NAVSHIPS 91393  
TT-47/UG, TT-48/UG, TT-69/UG, TT-70/UG

PARTS LISTS

## PARTS LISTS

NAVSHIPS 91393  
TT-47/UG, TT-48/UG, TT-69/UG, TT-70/UGSection 8  
H-2043—H-2063

H-2043	Same as H-118	Holds A-1333 to left side frame																		
H-2044	Same as H-330	Retains O-2044 on O-2016																		
H-2045	Same as H-119	Holds O-2036 and O-2038 to O-2051																		
H-2046	SCREW, machine: wrench drive; Hex H; steel, nickel plated finish; #6-40; approx 3/8" lg x 5/16" across flats o/a; 1/4" lg threaded portion; head 1/16" thk x 5/16" across flats	Holds O-2036 and O-2038 to O-2051	N17-T-350014-273	CTT	150780	150780	H-2046		1	1	1	-	-							
H-2047	Same as H-199	Retains O-2051 on A-1331																		
H-2048	Same as H-2018	Spring post for left side of O-2021																		
H-2049	Same as H-147	Holds H-2048 to O-2021																		
H-2050	Same as H-796	Holds H-2048 to O-2021																		
H-2051	Same as H-2011	Pivot for and mounts O-2021 to left side frame																		
H-2052	Same as H-118	Holds H-2051 to left side frame																		
H-2053	Same as H-119	Holds H-2052 to left side frame																		
H-2054	Same as H-121	Holds O-2025 to left side frame																		
H-2055	Same as H-118	Holds O-2025 to left side frame																		
H-2056	Same as H-799	Guides O-2024																		
H-2057	SCREW, set: slot drive; headless; steel, nickel plated; #6-40; approx 3/16" lg o/a; oval point	Holds O-2056 to right end of O-2057	N17-T-350013-170	CTT	6807	6807	H-2057, H-2061		3	1	2	-	-							
H-2058	Same as H-530	Holds O-2053 and O-2054 to right side frame																		
H-2059	Same as H-147	Holds O-2053 and O-2054 to right side frame																		
H-2060	Same as H-104	Holds O-2053 and O-2054 to right side frame																		
H-2061	Same as H-2057	Holds O-2058 to left end of O-2057																		
H-2062	Same as H-530	Holds O-2058 and O-2059 to left side frame																		
H-2063	Same as H-147	Holds O-2058 and O-2059 to left side frame																		

CHANGE 1

8-85

8-86

CHANGE 1

TABLE 8-4. COMBINED PARTS AND SPARE PARTS LIST

SYMBOL DESIG.	NAME OF PART AND DESCRIPTION	FUNCTION	JAN OR NAVY TYPE DESIGNATION	STANDARD NAVY STOCK NUMBER	MANUFACTURERS		TELETYPE PART NO.	ALL SYMBOL DESIGNATIONS INVOLVED	TOTAL NO. PER EQUIP.	SPARE PARTS					
					FED. CODE	DESIG.				EQUIP.		STOCK			
										BOX	QUAN.	BOX	QUAN.		
h-2064	Same as H-104	Holds O-2058 and O-2059 to left side frame													
H-2065	Same as H-121	Holds O-2062 and O-2063 to right side frame													
H-2066	Same as H-118	Holds O-2062 and O-2063 to right side frame													
H-2067	Same as H-330	Retains O-2069 on O-2063													
H-2068	Same as H-330	Retains O-2069 on O-2073													
H-2069	Same as H-516	Holds O-2074 to right side frame													
H-2070	Same as H-118	Holds O-2074 to right side frame													
H-2071	Same as H-1150	Holds A-1334 and O-2070 to A-1335													
H-2072	Same as H-118	Holds A-1334 and O-2070 to A-1335													
H-2073	Same as H-1150	Holds A-1334 and O-2070 to A-1336													
H-2074	Same as H-118	Holds A-1334 and O-2070 to A-1336													
H-2075	Same as H-132	Holds A-1335 to right side frame													
H-2076	Same as H-118	Holds A-1335 to right side frame													
H-2077	Same as H-132	Holds A-1336 to left side frame													
H-2078	Same as H-118	Holds A-1336 to left side frame													
H-2079	SCREW, machine: slot drive; FH; steel, nickel plated; 4-40; approx 7/8" lg o/a; 5/16" lg threaded portion; head 3/32" thk x 3/16" diam	Holds H-2080 and O-2075 to O-2074		N17-T-350002-267	CTT	80508	80508	H-2079, H-2081	14	-	-	-	-		
H-2080	CLAMP: steel, nickel plated; rounded on end, formed other end; approx 1/2" lg x 7/16" h x 1/8" wd o/a, 0.035" thk material; mts by hole in rounded end	Clamps O-2072 to O-2074		N17-T-350013-973	CTT	150267	150267	H-2080	4	-	-	-	-		
H-2081	Same as H-2079	Holds O-2076 to O-2074													

8 Section  
H-2064—H-2081

TT-47/UG, TT-48/UG, TT-69/UG, TT-70/UG

NAVSHIPS 91393

PARTS LISTS

H-2082	PIN: stainless steel; c/o round head and body; approx 3/16" lg x 1/8" diam o/a; mts by body	Bearing surface for left end of O-2065	N17-T-350014-784	CTT	151703	151703	H-2082	1	-	-	-	-
H-2083	Same as H-147	Holds H-2080 and O-2075 to O-2074										
H-2084	Same as H-106	Holds H-2080 and O-2075 to O-2074										
H-2085	Same as H-147	Holds O-2076 to O-2074										
H-2086	Same as H-106	Holds O-2076 to O-2074										
H-2087	Same as H-121	Holds A-1337 to right side frame										
H-2088	Same as H-118	Holds A-1337 to right side frame										
H-2090	Same as H-257	Holds O-2083 to right side frame										
H-2091	Same as H-147	Holds O-2083 to right side frame										
H-2092	Same as H-118	Holds O-2084 to left side frame										
H-2093	Same as H-1150	Holds O-2084 to left side frame										
H-2094	Same as H-257	Holds A-1338 to left side frame										
H-2095	Same as H-147	Holds A-1338 to left side frame										
H-2096	Same as H-121	Holds O-2087 and O-2090 to left side frame										
H-2097	Same as H-125	Holds O-2087 and O-2090 to left side frame										
H-2098	Same as H-118	Holds O-2087 and O-2090 to left side frame										
H-2100	Same as H-121	Holds O-2088 to left side frame										
H-2101	Same as H-118	Holds O-2088 to left side frame										
H-2102	Same as H-119	Holds O-2088 to left side frame										
H-2103	Same as H-257	Holds O-2089 to left side frame										
H-2104	Same as H-147	Holds O-2089 to left side frame										

CHANGE 1

8-87



TABLE 8-4. COMBINED PARTS AND SPARE PARTS LIST

SYMBOL DESIG.	NAME OF PART AND DESCRIPTION	FUNCTION	JAN OR NAVY TYPE DESIGNATION	STANDARD NAVY STOCK NUMBER	MANUFAC- TURERS		TELETYPE PART NO.	ALL SYMBOL DESIGNATIONS INVOLVED	TOTAL NO. PER EQUIP.	SPARE PARTS									
					CODE	DESIG.				EQUIP.		STOCK							
										BOX	QUAN.	BOX	QUAN.						
H-2105	Same as H-121	Holds A-1339 to left side frame																	
H-2106	Same as H-118	Holds A-1339 to left side frame																	
H-2108	POST, spring; steel, nickel plated; c/o shank w/two grooves, threaded head, hex body and shank w/two grooves; approx 2 5/16" lg x 1/4" across flats o/a; mts by threaded head	Anchor for O-1726, O-1731, O-1736 and O-1739		N17-T-350014-625	CTT	150341	150341	H-2108	1	-	-	-	-	-	-	-	-	-	-
H-2109	Same as H-189	Holds H-2108 to left side frame																	
H-2110	Same as H-188	Holds H-2108 to left side frame																	
H-2111	POST, eccentric; steel, nickel plated; hex body w/off ctr shank 1 end; approx 13/16" lg x 1/4" across flats o/a; mts by #10-32 tapped hole in 1 end of body	Adjustable stop for O-1724		N17-T-350014-532	CTT	150351	150351	H-2111, H-2116	2	-	-	-	-	-	-	-	-	-	-
H-2112	Same as H-188	Locks H-2111 to H-2114																	
H-2113	Same as H-189	Holds H-2114 to left side frame																	
H-2114	STUD; steel, nickel plated; approx 1" lg x 1/4" across flats; #10-32 thread both ends, 1 end 5/16" lg, other end 9/16" lg; hex head 3/32" thk	Mounts H-2111 and H-2116		N17-T-350014-632	CTT	150353	150353	H-2114	1	-	-	-	-	-	-	-	-	-	-
H-2115	Same as H-188	Locks H-2116 to H-2114																	
H-2116	Same as H-2111	Adjustable stop for O-1735																	
H-2117	Same as H-188	Holds H-2114 to left side frame																	
H-2118	STUD, eccentric; steel, nickel plated finish; 31/32" lg x 5/16" across flats; 1 end #6-40 thd 1/4" lg, other end #6-40 thd 7/32" lg; slot between head and body	Pivot for and mounts O-2092 and O-2101		N17-T-350014-536	CTT	150471	150471	H-2118	1	-	-	-	-	-	-	-	-	-	-
H-2119	STUD; steel, nickel plated; approx 7/8" lg x 1/4" across flats o/a; c/o shank, head, neck, and body, #6-40 thd 1/8" lg on body near head	Mounts O-2093 and O-2103		N17-T-350014-367	CTT	151669	151669	H-2119	1	1	1	-	-	-	-	-	-	-	-
H-2120	Same as H-1129	Locks O-2097 to H-2119																	
H-2121	Same as H-257	Holds A-1341 to O-2104																	



TABLE 8-4. COMBINED PARTS AND SPARE PARTS LIST

SYMBOL DESIG.	NAME OF PART AND DESCRIPTION	FUNCTION	JAN OR NAVY TYPE DESIGNATION	STANDARD NAVY STOCK NUMBER	MANUFACTURERS		TELETYPE PART NO.	ALL SYMBOL DESIGNATIONS INVOLVED	SPARE PARTS										
					MFG CODE	DESIG.			TOTAL NO. PER EQUIP.	EQUIP.		STOCK							
										BOX	QUAN.	BOX	QUAN.						
H-2147	Same as H-796	Holds O-2105 and O-2119 to O-2114																	
H-2148	Same as H-1326	Holds H-2157, O-2118 and O-1529 to O-1935																	
H-2149	Same as H-118	Holds H-2157, O-2118 and O-1529 to O-1935																	
H-2150	Same as H-121	Holds O-2114 to O-2108																	
H-2151	Same as H-118	Holds O-2114 to O-2108																	
H-2152	Same as H-516	Holds O-2107 to right side frame																	
H-2153	Same as H-118	Holds O-2107 to right side frame																	
H-2154	Same as H-1907	Post for and connects O-1768 to O-2115																	
H-2155	Same as H-118	Holds H-2154 to O-2115																	
H-2156	Same as H-119	Holds H-2154 to O-2115																	
H-2157	HOLDER, wick: steel, nickel plated; cylindrical w/90° arm at base; approx 1" lg x 3/8" OD x 5/16" ID o/a; mts by ID, hole in arm	Retainer for O-2117		N17-T-350014-588	CTT	151635	151635	H-2157	1	-	-	-	-	-	-	-	-	-	-
H-2158	PLATE: steel, nickel plated; oblong; 21/32" lg x 5/16" wd x 0.095" thk o/a; mts by 2 tapped holes	Nut plate for O-2104, O-2114 and O-2120		N17-T-350014-541	CTT	150482	150482	H-2158	1	-	-	-	-	-	-	-	-	-	-
H-2159	STUD: steel, nickel plated; approx 3/8" lg x 3/16" across flats o/a; one end threaded 3/32" lg w/#4-40 thd; slot back of thd, hex shoulder and body	Stop for O-2054		N17-T-350014-362	CTT	150992	150992	H-2159, H-2161	2	-	-	-	-	-	-	-	-	-	-
H-2160	Same as H-118	Holds H-2159 to right side frame																	
H-2161	Same as H-2159	Stop for O-2059																	
H-2162	Same as H-118	Holds H-2161 to left side frame																	
H-2163	Same as H-118	Holds H-1760 to O-1755																	
H-2164	Same as H-119	Holds H-1760 to O-1755																	

CHANGE 1	H-2165	CLAMP: cable; cellulose plastic; one bolt employed; approx 1/2" wd x 1" lg x 7/16" ID x 9/16" h o/a, 1/16" thk material; accommodates 7/16" diam cable	Clamps W-1302 to right side frame	N17-C-781241-292	COMMERCIAL PLASTICS CO. CPC-7427	121247	H-2165	1	-	-	-	-	
	H-2166	Same as H-141	Holds H-2165 to right side frame										
	H-2167	Same as H-118	Holds H-2165 to right side frame										
	H-2168	Same as H-104	Holds H-2165 to right side frame										
	H-2169	WASHER, flat: steel, nickel plated; round, approx 3/8" OD x 5/32" ID x 0.050" thk o/a	Holds W-1303 to O-1693	N17-T-350014-797	CTT	90790	90790	H-2169, H-2170	2	-	-	-	-
	H-2170	Same as H-2169	Holds W-1304 to O-1693										
	H-2171	WASHER, flat: steel, nickel plated; round, approx 7/16" OD x 5/32" ID x 1/32" thk o/a	Bearing surface for and holds O-1926 on O-1931	N17-T-350013-202	CTT	76099	76099	H-2171, H-2172	2	1	1	-	-
	H-2172	Same as H-2171	Bearing surface for and holds O-2008 to O-2007										
	H-2173	Same as H-799	Bearing surface for O-1965										
	H-2174	Same as H-799	Bearing surface for O-1970										
	H-2175	Same as H-302	Holds O-1839 to O-1840										
	SYMBOL DESIGNATIONS I-751 AND I-752 USED ON CY-870/UG AND CY-871/UG CABINETS												
	I-751	Same as E-751	Pilot light for end of line indication										
	I-752	GONG: steel, nickel plated; curved on 1 side, dished out on other side; approx 3" diam x 1" lg o/a, 0.072" thk material; mts by body hole w/two cutouts in ctr of gong	Signal bell for the attendant	# N17-T-350006-899	CTT	43954	43954	I-752	1	-	-	-	-
	J-101	CONNECTOR, receptacle: 14 round male contacts; straight; approx 1 7/8" lg x 15/32" wd x 27/32" h o/a; rectangular, molded melamine body; molded melamine inserts; mts by two #4-40 studs on 15/64" x 1 9/16" mtg/ctrs; guide pin near ea end	Termination for W-101	N17-C-73588-3386	WINGMASTER ELECTRONICS INC. 12-2P		151815	J-101, J-1301	2	-	-	-	-
J-1103	CONNECTOR, receptacle: 2 flat parallel blades; straight type; approx 1 1/8" lg x 1 1/2" wd x 9/16" thk o/a; 110 volt; mts by 2 body holes in shoulder	Convenience receptacle	N17-C-73137-1875	CMG	#12844	151422	J-1103	1	-	-	-	-	
J-1301	Same as J-101	Termination for W-1302											

# I-751 and I-752 used on CY-870/UG and CY-871/UG

TABLE 8-4. COMBINED PARTS AND SPARE PARTS LIST

SYMBOL DESIG.	NAME OF PART AND DESCRIPTION	FUNCTION	JAN OR NAVY TYPE DESIGNATION	STANDARD NAVY STOCK NUMBER	MANUFAC- TURERS		TELETYPE PART NO.	ALL SYMBOL DESIGNATIONS INVOLVED	SPARE PARTS				
					CODE	DESIG.			TOTAL NO. PER EQUIP.	EQUIP.		STOCK	
										BOX	QUAN.	BOX	QUAN.
K-101	CONTACT ASSEMBLY: c/o terminals, box, cover, bracket, toggle, guide, toggle extension, spring, toggle link, base and contact screws; base screwed across approx ctr box; guide mtd 1 end, 2 contact screws mtd 1 side of base w/terminal connected to ea; toggle link connected by spring to terminal on other side of base, link holds toggle in position over contact, extension toggle assembled to toggle and extends through guide and through slot in side of box, cover screwed to top of box, bracket formed on 1 end w/elongated slot mtd on bottom of box; approx 1 3/4" h x 2 1/2" lg x 1 1/8" wd o/a; mts by 2 elongated holes in adjusting bracket	Receives incoming signals and sets up selector code on MX-1115/UG		N17-T-350014-756	CTT	151170	151170	K-101	1	-	-	-	-
K-501	RELAY, motor starting: SPST normally open; single winding, 6.1 amps AC operating current, 5.2 amps release current, insulated; solder lug terminals on coil and contacts; approx 1 27/32" lg x 1 1/4" wd x 1 1/16" h o/a; clamp mtd; fast acting; dustproof cover	Starting relay for PL-17A/U			CTT	151923	151923	K-501	1	-	-	-	-
K-1101	RELAY, armature: DPDT, 1 set normally closed, 1 set normally open; contact rating 8 amps, 115 v AC; fine silver contacts, approx 3/16" diam; single winding, 115 v AC, 60 cyc, insulated coil; solder lug term on coil and contacts; approx 2 9/16" lg x 2 3/16" wd x 1 3/4" h o/a; mts by 2 body holes, approx 1/4" diam on 2 1/4" mtg/c; fast acting	Shunts signal line when S-1103 is in off position		N17-R-64362-8037	CARB	MR11A	151808	K-1101	1	-	-	-	-
O-101	PAWL: steel, nickel plated; irregular shape, 1 arm and 1 ear; approx 2 3/16" lg x 3/4" wd x 0.083" thk o/a; mts by large hole, csk 1 side below arm; body hole csk both sides in rounded end	Operates S-101		N17-T-350013-691	CTT	151239	151239	O-101	1	-	-	-	-
O-102	SPRING: helical extension type; 0.014" diam music wire; approx 27/32" lg x 5/32" OD x 1/8" ID o/a; approx 44 turns; parallel hook term ea end; mts by terms	Applies tension to O-101		N17-T-350012-708	CTT	31636	31636	O-102, O-2055, O-2061	3	1	1	-	-
O-103	WASHER, felt, hard, white felt, round, 7/32" ID x 3/8" OD x 1/16" thk	Lubricates O-101 and O-104		N17-T-350013-794	CTT	109757	109757	O-103, O-106, O-109, O-1533, O-1548, O-1557, O-1561, O-1621	8	1	7	-	-
O-104	BUSHING: steel, nickel plated; male and female; approx 5/16" lg x 9/32" OD x 1/8" ID o/a, 5/32" lg x 7/32" diam shoulder	Bearing for O-101		N17-T-350013-694	CTT	151242	151242	O-104, O-107, O-110	3	-	-	-	-
O-105	LEVER: steel, nickel plated; irregular shape w/rounded ear; approx 1 3/16" lg x 15/16" wd x 0.083" thk o/a; mts by large hole in rounded p/o body csk 1 side; body hole csk both sides in ear	Operates O-101		N17-T-350013-693	CTT	151241	151241	O-105	1	-	-	-	-
O-106	Same as O-103	Lubricates O-105 and O-107											
O-107	Same as O-104	Bearing for O-105											

CHANGE 1

0-108	PAWL: steel, nickel plated; irregularly shaped curved body; approx 13/16" lg x 11/16" wd x 0.083" thk o/a; mts by large body hole in rounded p/o body; body hole csk both sides near 1 end	Operates 0-105	N17-T-350013-692	CTT	151240	151240	0-108	1	-	-	-	-	-
0-109	Same as 0-103	Lubricates 0-108 and 0-110											
0-110	Same as 0-104	Bearing for 0-108											
0-111	SPRING: flat type; 0.010" thk nickel silver; approx 3/4" lg x 3/4" h x 1/32" wd o/a; mts by hole in ctr; 3 equidistant blades	Applies tension to 0-112	N17-T-350013-689	CTT	151237	151237	0-111, 0-115	2	1	1	-	-	-
0-112	RATCHET: moulded black bakelite; approx 7/8" OD x 3/8" ID x 1/8" thk o/a; mts by ctb ID; 27 teeth around OD w/cutout 1 side	Operates 0-108	N17-T-350013-687	CTT	151234	151234	0-112	1	1	1	-	-	-
0-113	HUB: steel, nickel plated; approx 9/32" lg x 1/2" OD x 1/8" ID o/a; mts by ID; 3/32" wd shoulder between two 3/32" wd shanks	Bearing for 0-112 and 0-114	N17-T-350013-688	CTT	151236	151236	0-113	1	-	-	-	-	-
0-114	RATCHET: moulded black bakelite; approx 7/8" OD x 3/8" ID x 1/8" thk o/a; mts by ctb ID; 28 teeth around OD w/cutout 1 side	Operates 0-108	N17-T-350013-686	CTT	151235	151235	0-114	1	1	1	-	-	-
0-115	Same as 0-111	Applies tension to 0-114											
0-116	SPACER: steel, nickel plated; extruded 3/16" diam, 1 side; approx 3/8" OD x 1/8" ID x 3/32" lg o/a; mts by ID	Support for 0-115	N17-T-350013-690	CTT	151238	151238	0-116	1	-	-	-	-	-
0-117	SPRING: helical extension type; 0.016" diam music wire; approx 1/2" lg x 5/32" OD x 1/8" ID o/a; approx 14 turns; parallel hook term ea end; mts by terms	Applies tension to 0-108	N17-T-350006-407	CTT	45104	45104	0-117, 0-241, 0-1111, 0-1494	4	1	2	-	-	-
0-118	SPACER: steel, nickel plated; approx 3/16" OD x 3/32" ID x 1/16" thk o/a; mts by ID	Spaces S-101 and A-101	N17-T-350013-685	CTT	151233	151233	0-118	2	-	-	-	-	-
0-119	PLATE: steel, nickel plated; both ends curved to widened "U" shape; approx 2 9/16" lg x 1" wd x 0.065" thk o/a; mts by 3 tapped holes	Locks A-101 to keyboard	N17-T-350014-584	CTT	151220	151220	0-119	1	-	-	-	-	-
0-120	PAWL: steel, nickel plated; irregular shape 1 end curved and formed, other end large and rounded w/lg thin arm, rounded ear w/body hole in approx ctr of body; approx 5 1/2" lg x 1 1/4" h x 7/16" wd o/a, 0.050" thk material; mts by body hole in rounded end	Steps 0-112 and 0-114	N17-T-350013-695	CTT	151243	151243	0-120	1	-	-	-	-	-
0-121	SPRING: helical extension type; 0.018" diam music wire; approx 5/8" lg x 5/32" OD o/a; approx 21 turns; parallel hook terminals; mts by terminals	Applies tension to 0-120	N17-T-350012-235	CTT	110436	110436	0-121, 0-1584	2	1	1	-	-	-
0-122	PLATE, spacer: steel, nickel plated; rounded ends; approx 1 5/16" lg x 5/8" wd x 0.065" thk o/a; mts by 1 large and 1 small body hole	Spacer for MA-1115/UG	N17-T-350014-463	CTT	151118	151118	0-122	4	-	-	-	-	-

PARTS LISTS

TT-47/UG, TT-48/UG, TT-69/UG, TT-70/UG

NAVSHIPS 91393

Section 8  
O-108—O-122

8-93

8-94

TABLE 8-4. COMBINED PARTS AND SPARE PARTS LIST

SYMBOL DESIG.	NAME OF PART AND DESCRIPTION	FUNCTION	JAN OR NAVY TYPE DESIGNATION	STANDARD NAVY STOCK NUMBER	MANUFAC- TURERS		TELETYPE PART NO.	ALL SYMBOL DESIGNATIONS INVOLVED	SPARE PARTS				
					CODE	DESIG.			TOTAL NO. PER EQUIP.	EQUIP.		STOCK	
										BOX	QUAN.	BOX	QUAN.
0-124	LEVER: steel, nickel plated; irregular shape w/two formed ends and 1 curved body ear, hub welded at curve in body; approx 1 13/16" lg x 1 7/16" h x 7/16" wd o/a, 0.035" thk material; mts by ID of hub	Operates S-102		N17-T-350013-707	CTT	151341	151341	0-124	1	-	-	-	-
0-125	SPRING: helical extension type; 0.016" diam music wire; approx 23/32" lg x 5/32" OD x 1/8" ID o/a; approx 26 turns; parallel hook term ea end; mts by terms	Applies tension to 0-124		N17-T-350012-711	CTT	49420	49420	0-125, 0-254, 0-1309	3	1	2	-	-
0-126	BELL CRANK: steel, nickel plated; irregular "L" shape; approx 1 3/8" lg x 3/4" h x 0.050" thk o/a; mts by tapped hole in rounded end of "L"; body hole csk both sides narrow end, large body in corner	Operates 0-131		N17-T-350014-405	CTT	151032	151032	0-126	1	-	-	-	-
0-127	SPRING: helical extension type; 0.010" diam music wire; approx 1/2" lg x 1/8" OD o/a; approx 28 turns; hook terms indexed 90°; mts by terms	Applies tension to 0-126 and 0-128		N17-T-350004-754	CTT	112634	112634	0-127, 0-1427	3	1	2	-	-
0-128	LEVER: steel, nickel plated; irregular shape w/one body ear, 1 end rounded; approx 2 1/2" lg x 1/4" h x 0.050" thk o/a; mts by hole in rounded end; body hole csk both sides near ctr	Operates 0-126		N17-T-350014-406	CTT	151033	151033	0-128	1	-	-	-	-
0-129	PLATE: steel, nickel plated; irregular shaped, formed near 1 end, cutout on 1 side; approx 1 5/8" wd x 3 3/32" lg x 1/8" thk o/a, 0.065" thk material; mts by 2 holes on ea end, holes on 1 end tapped; 2 elongated holes in ear	Supports A-105 and A-104		N17-T-350013-718	CTT	151367	151367	0-129	1	-	-	-	-
0-130	PLATE: steel, nickel plated; ear on 1 corner, offset approx 1/16" at ctr; approx 1 9/16" lg x 1 1/4" h x 1/8" wd o/a, 0.065" thk material; mts by 4 tapped holes	Supports 0-129 and 0-104		N17-T-350013-719	CTT	151368	151368	0-130	1	-	-	-	-
0-131	LEVER: steel, nickel plated; 1 end irregular shaped, other end round w/elongated arm extending up, 2 ears on body; approx 3 1/8" lg x 7/8" h x 1/8" wd o/a, 0.050" thk material; mts by ID of bushing welded to round end; body hole csk both sides at end of arm	Operates 0-249		N17-T-350014-565	CTT	151008	151008	0-131	1	-	-	-	-
0-132	SPRING: helical extension; 0.014" diam music wire; 1" lg x 5/32" OD o/a; 47 turns; hook terminals; mts by hook ends	Applies tension to 0-131		N17-T-350007-458	CTT	70388	70388	0-132	1	-	-	-	-

CHANGE 1

8 Section  
O-124-O-132

TT-47/UG, TT-48/UG, TT-69/UG, TT-70/UG

NAVSHIPS 91393

PARTS LISTS

## PARTS LISTS

NAVSHIPS 91393  
TT-47/UG, TT-48/UG, TT-69/UG, TT-70/UGSection 8  
O-133—O-141

0-133	WICK: hard white felt; approx 1 3/4" lg x 3/32" diam o/a	Lubricates 0-132	N17-T-350001-418	CTT	4809	4809	0-133	1	-	-	-	-	-	-
0-134	BAIL: steel, nickel plated; irregularly formed, 6 narrow elongated slots 1 side, 5 wd elongated slots other side w/lock bail extension riveted near ctr, end plates copper brazed in place ea end; approx 8 1/8" lg x 7/8" h x 1 1/8" wd o/a; mts by 2 body holes in line in plates; 2 holes csk both sides in line in plates	Locks code bars	N17-T-350014-396	CTT	151011	151011	0-134	1	-	-	-	-	-	-
0-135	BAR, cluth trip: steel, nickel plated; approx 8 7/8" lg x 1/2" wd x 0.035" thk o/a; mts by body hole 1 end and by other; "G" stamped near mtg hole 2 cuts on upper side, 1 lg cutout along most of lower side	Operates 0-236	N17-T-350014-445	CTT	151084	151084	0-135	1	-	-	-	-	-	-
0-136	CODE BAR: steel, nickel plated; 2 cutouts upper side, 23 teeth irregularly spaced in lg cutout lower side; approx 9" lg x 1/2" wd x 0.035" thk o/a; mts by 2 body holes 1 end, and squared ear other end; "1" stamped near mtg holes	Positions 0-358 to 0-364	N17-T-350014-450	CTT	151089	151089	0-136	1	-	-	-	-	-	-
0-137	CODE BAR: steel, nickel plated; 2 cutouts upper side, 23 teeth irregularly spaced in lg cutout lower side; approx 9" lg x 1/2" wd x 0.035" thk o/a; mts by 2 body holes 1 end and squared ear other end; "2" stamped near mtg holes	Positions 0-358 to 0-364	N17-T-350014-449	CTT	151088	151088	0-137	1	-	-	-	-	-	-
0-138	CODE BAR: steel, nickel plated; 2 cutouts upper side, 23 teeth irregularly spaced in lg cutout lower side; approx 9" lg x 1/2" wd x 0.035" thk o/a; mts by 2 body holes 1 end and squared ear other end; "3" stamped near mtg holes	Positions 0-358 to 0-364	N17-T-350014-448	CTT	151087	151087	0-138	1	-	-	-	-	-	-
0-139	CODE BAR: steel, nickel plated; 2 cutouts upper side, 23 teeth irregularly spaced in lg cutout lower side; approx 9" lg x 1/2" wd x 0.035" thk o/a; mts by 2 body holes 1 end and squared ear other end; "4" stamped near mtg holes	Positions 0-358 to 0-364	N17-T-350014-447	CTT	151086	151086	0-139	1	-	-	-	-	-	-
0-140	CODE BAR: steel, nickel plated; 2 cutouts upper side, 23 teeth irregularly spaced in lg cutout lower side; approx 9" lg x 1/2" wd x 0.035" thk o/a; mts by 2 body holes 1 end and squared ear other end; "5" stamped near mtg holes	Positions 0-358 to 0-364	N17-T-350014-446	CTT	151085	151085	0-140	1	-	-	-	-	-	-
0-141	BAR, locking: steel, nickel plated; irregular shape cutout and wd cutout on top, 37 irregularly spaced teeth and pointed ear along inside of cutout along most of length on bottom; approx 8 13/16" lg x 9/16" wd x 0.035" thk o/a; mts by elongated hole 1 end and body hole other end; character "L" stamped near body hole	Locks 0-134	N17-T-350013-713	CTT	151355	151355	0-141	1	-	-	-	-	-	-

CHANGE 1

8-95



TABLE 8-4. COMBINED PARTS AND SPARE PARTS LIST

SYMBOL DESIG.	NAME OF PART AND DESCRIPTION	FUNCTION	JAN OR NAVY TYPE DESIGNATION	PARTS		TELETYPE PART NO.	ALL SYMBOL DESIGNATIONS INVOLVED	SPARE PARTS							
				STANDARD NAVY STOCK NUMBER	MANUFAC- TURERS CODE			EQUIP.	STOCK		TOT AL NO PER EQUIP.	BOX	QUAN.	BOX	QUAN.
									DESIG.	DESIG.					
0-142	GUIDE, code bar: steel, nickel plated; rectangular shape, formed 1 side w/rounded ear 1 end; approx 1 3/8" lg x 1 1/8" h x 1/4" wd o/a, 0.028" thk material; mts by 2 elongated holes; elongated slot w/two connecting strips across and 10 teeth on ea side, body hole in ear	Guide for 0-135 to 0-141		N17-T-350014-400	CTT	151023	151023	0-142, 0-303	2	-	-	-	-	-	
0-143	PLATE: steel, nickel plated; approx 1 1/2" lg x 1 3/32" wd x 1/8" thk o/a; mts by holes near ea end	Spaces 0-142 and A-107		N17-T-350014-452	CTT	151091	151091	0-143	1	-	-	-	-	-	
0-144	PLATE: steel, nickel plated; approx 1 1/2" lg x 1 3/32" wd x 3/32" thk o/a; mts by 2 tapped holes	Locks 0-303 to A-106		N17-T-350014-413	CTT	151043	151043	0-144	1	-	-	-	-	-	
0-145	SPRING: helical extension type; 0.012" diam music wire; approx 1/2" lg x 5/32" OD o/a; approx 20 turns; parallel hook term ea end; mts by terms	Applies tension to 0-303			CTT	7618	7618	0-145	1	-	-	-	-	-	
0-146	WICK: hard, white felt; approx 3/32" diam x 1 1/16" lg o/a	Lubricates 0-147		N17-T-350013-716	CTT	151362	151362	0-146	6	1	3	-	-	-	
0-147	SPRING: helical extension type; 0.010" diam music wire; approx 7/16" lg x 1/8" OD x 3/32" ID o/a; approx 20 turns; parallel hook term ea end; mts by terms	Applies tension to 0-136, 0-137, 0-138, 0-139, 0-140, or 0-141		N17-T-350006-406	CTT	42661	42661	0-147, 0-368	7	-	-	-	-	-	
0-148	SPRING: helical extension type; 0.014" diam music wire; approx 15/32" lg x 5/32" OD x 1/8" ID o/a; approx 16 turns; parallel hook term ea end; mts by terms	Applies tension to 0-135		N17-T-350006-393	CTT	7603	7603	0-148, 0-198, 0-247, 0-1110, 0-1434	52	1	5	-	-	-	
0-149	SHAFT: steel, nickel plated; approx 8 3/4" lg x 3/16" OD; mts by ends; 1 end tapered, shank on other end w/groove near shank	Pivot for code levers		N17-T-350014-404	CTT	151030	151030	0-149	1	-	-	-	-	-	
0-150	CLIP: retaining; steel; approx 1" lg x 3/8" wd o/a, 0.040" diam music wire; approx 9/16" jaw opening	Holds 0-149 to A-106		N17-T-350014-431	CTT	151104	151104	0-150	4	1	1	-	-	-	
0-151	KEY LEVER: steel, nickel plated lever w/cellulose acetate butyrate (Tenite II) top; irregular shape, round keytop concave on top and tapered to point on bottom pressed on 1 end of lever; approx 2 3/4" lg x 2" wd x 0.042" thk material o/a, 1/2" diam keytop; mts by irregular shape elongated slot in lower end of lever; red keytop w/white characters "LOC LF"	Operates 0-318		N17-T-350014-170	CTT	151286	151286	0-151	1	-	-	-	-	-	

## PARTS LISTS

## NAVSHIPS 91393

TT-47/UG, TT-48/UG, TT-69/UG, TT-70/UG

Section 8  
O-152—O-157

0-152	KEY LEVER: steel, nickel plated lever w/cellulose acetate butyrate (Tenite II) top; irregular shape, round keytop concave on top and tapered to points on bottom pressed on 1 end of lever; approx 2 3/4" lg x 2" wd x 0.042" thk material o/a, 1/2" diam keytop; mts by irregular shape elongated slot in lower end of lever; red keytop w/white characters "REPT"	Operates 0-317	N17-T-350014-174	CTT	151291	151291	0-152	1	-	-	-	-	-
0-153	KEY LEVER: steel, nickel plated lever w/cellulose acetate butyrate (Tenite II) top; irregular shape, round keytop concave on top and tapered to point on bottom, pressed on 1 end of lever; approx 2 3/4" lg x 2" wd x 0.042" thk material o/a, 1/2" diam keytop; mts by irregular shape elongated slot in lower end of lever; red keytop w/white characters "LOC CR"	Operates 0-319	N17-T-350014-171	CTT	151287	151287	0-153	1	-	-	-	-	-
0-154	KEY LEVER: steel, nickel plated lever w/cellulose acetate butyrate (Tenite II) top; irregular shape, round keytop concave on top and tapered to point on bottom, pressed on 1 end of lever; approx 2 3/4" lg x 2" wd x 0.042" thk material o/a, 1/2" diam keytop; mts by irregular shape elongated slot in lower end of lever; red keytop w/white characters "KBD UNLK"	Operates 0-315	N17-T-350014-172	CTT	151288	151288	0-154	1	-	-	-	-	-
0-155	KEY LEVER: steel, nickel plated lever w/cellulose acetate butyrate (Tenite II) top; irregular shape, round keytop concave on top and tapered to point on bottom, pressed on 1 end of lever, approx 2 3/4" lg x 2" wd x 0.042" thk material o/a, 1/2" diam keytop; mts by irregular shape elongated slot in lower end of lever; red keytop w/white characters "KBD LOCK"	Operates 0-314	N17-T-350014-173	CTT	151289	151289	0-155	1	-	-	-	-	-
0-156	KEY LEVER: steel, nickel plated lever w/cellulose acetate butyrate (Tenite II) top; irregular shape, round keytop concave on top and tapered to point on bottom, pressed on 1 end of lever; approx 2 3/4" lg x 2" wd x 0.042" thk material o/a, 1/2" diam keytop, mts by irregular shape elongated slot in lower end of lever; red keytop w/white characters "BREAK"	Operates 0-316	N17-T-350014-169	CTT	151290	151290	0-156	1	-	-	-	-	-
0-157	KEY LEVER: steel, nickel plated lever w/cellulose acetate butyrate (Tenite II) top; irregular shape, round keytop concave on top and tapered to point on bottom pressed on 1 end of lever; approx 2 1/2" lg x 1 1/4" wd x 0.042" thk material o/a, 1/2" diam keytop; mts by irregular shape elongated slot in lower end of lever; green keytop w/white characters "2, W"	Operates 0-320	N17-T-350014-176	CTT	151293	151293	0-157	1	-	-	-	-	-

CHANGE 1

8-97

TABLE 8-4. COMBINED PARTS AND SPARE PARTS LIST

SYMBOL DESIG.	NAME OF PART AND DESCRIPTION	FUNCTION	JAN OR NAVY TYPE DESIGNATION	STANDARD NAVY STOCK NUMBER	MANUFAC- TURERS		TELETYPE PART NO.	ALL SYMBOL DESIGNATIONS INVOLVED	SPARE PARTS				
					FED CODE	DESIG.			TOTAL NO. PER EQUIP.	EQUIP.		STOCK	
										BOX	QUAN.	BOX	QUAN.
0-158	KEY LEVER: steel, nickel plated lever w/cellulose acetate butyrate (Tenite II) top; irregular shape, round keytop concave on top and tapered to point on bottom pressed on 1 end of lever; approx 2 1/2" lg x 1 1/4" wd x 0.042" thk material o/a, 1/2" diam keytop; mts by irregular shape elongated slot in lower end of lever; green keytop w/white characters "1, Q"	Operates 0-321		N17-T-350014-175	CTT	151292	151292	0-158	1	-	-	-	-
0-159	KEY LEVER: steel, nickel plated lever w/cellulose acetate butyrate (Tenite II) top; irregular shape, round keytop concave on top and tapered to point on bottom pressed on 1 end of lever; approx 2 1/2" lg x 1 1/4" wd x 0.042" thk material o/a, 1/2" diam keytop; mts by irregular shape elongated slot in lower end of lever; green keytop w/white characters "3, E"	Operates 0-322		N17-T-350014-177	CTT	151294	151294	0-159	1	-	-	-	-
0-160	KEY LEVER: steel, nickel plated lever w/cellulose acetate butyrate (Tenite II) top; irregular shape, round keytop concave on top and tapered to point on bottom pressed on 1 end of lever; approx 2 1/2" lg x 1 1/4" wd x 0.042" thk material o/a, 1/2" diam keytop; mts by irregular shape elongated slot in lower end of lever; green keytop w/white character "4, R"	Operates 0-323		N17-T-350014-251	CTT	151295	151295	0-160	1	-	-	-	-
0-161	KEY LEVER: steel, nickel plated lever w/cellulose acetate butyrate (Tenite II) top; irregular shape, round keytop concave on top and tapered to point on bottom pressed on 1 end of lever; approx 2 1/2" lg x 1 1/4" wd x 0.042" thk material o/a, 1/2" diam keytop; mts by irregular shape elongated slot in lower end of lever; green keytop w/white character "5, T"	Operates 0-324		N17-T-350014-178	CTT	151296	151296	0-161	1	-	-	-	-
0-162	KEY LEVER: steel, nickel plated lever w/cellulose acetate butyrate (Tenite II) top; irregular shape, round keytop concave on top and tapered to point on bottom pressed on 1 end of lever; approx 2 1/2" lg x 1 1/4" wd x 0.042" thk material o/a, 1/2" diam keytop; mts by irregular shape elongated slot in lower end of lever; green keytop w/white characters "6, Y"	Operates 0-325		N17-T-350014-179	CTT	151297	151297	0-162	1	-	-	-	-

8-98

CHANGE 1

0-163	KEY LEVER: steel, nickel plated lever w/cellulose acetate butyrate (Tenite II) top; irregular shape, round keytop concave on top and tapered to point on bottom pressed on 1 end of lever; approx 2 1/2" lg x 1 1/4" wd x 0.042" thk material o/a, 1/2" diam keytop; mts by irregular shape elongated slot in lower end of lever; green keytop w/white characters "7, U"	Operates 0-326	N17-T-350014-180	CTT	151298	151298	0-163	1	-	-	-	-
0-164	KEY LEVER: steel, nickel plated lever w/cellulose acetate butyrate (Tenite II) top; irregular shape, round keytop concave on top and tapered to point on bottom, pressed on 1 end of lever; approx 2 1/2" lg x 1 1/4" wd x 0.042" thk material o/a, 1/2" diam keytop; mts by irregular shape elongated slot in lower end of lever; green keytop w/white characters "8, I"	Operates 0-327	N17-T-350014-181	CTT	151299	151299	0-164	1	-	-	-	-
0-165	KEY LEVER: steel, nickel plated lever w/cellulose acetate butyrate (Tenite II) top; irregular shape, round keytop concave on top and tapered to point on bottom pressed on 1 end of lever; approx 2 1/2" lg x 1 1/4" wd x 0.042" thk material o/a, 1/2" diam keytop; mts by irregular shape elongated slot in lower end of lever; green keytop w/white character "9, O"	Operates 0-328	N17-T-350014-182	CTT	151300	151300	0-165	1	-	-	-	-
0-166	KEY LEVER: steel, nickel plated lever w/cellulose acetate butyrate (Tenite II) top; irregular shape, round keytop concave on top and tapered to point on bottom pressed on 1 end of lever; approx 2 1/2" lg x 1 1/4" wd x 0.042" thk material o/a, 1/2" diam keytop; mts by irregular shape elongated slot in lower end of lever; green keytop w/white characters "ø, P"	Operates 0-329	N17-T-350014-183	CTT	151301	151301	0-166	1	-	-	-	-
0-167	KEY LEVER: steel, nickel plated lever w/cellulose acetate butyrate (Tenite II) top; irregular shape, round keytop concave on top and tapered to point on bottom pressed on 1 end of lever; approx 2 1/4" lg x 1/2" diam keytop o/a, 0.042" thk material; mts by irregular shape elongated slot in lower end of lever; green keytop w/white characters "., A"	Operates 0-330	N17-T-350014-184	CTT	151302	151302	0-167	1	-	-	-	-
0-168	KEY LEVER: steel, nickel plated lever w/cellulose acetate butyrate (Tenite II) top; irregular shape, round keytop concave on top and tapered to point on bottom pressed on 1 end of lever; approx 2 1/4" lg x 1/2" diam keytop o/a, 0.042" thk material; mts by irregular shape elongated slot in lower end of lever; green keytop w/white characters "BELL, S"	Operates 0-331	N17-T-350014-185	CTT	151303	151303	0-168	1	-	-	-	-

CHANGE 1

8-99

TABLE 8-4. COMBINED PARTS AND SPARE PARTS LIST

SYMBOL DESIG.	NAME OF PART AND DESCRIPTION	FUNCTION	JAN OR NAVY TYPE DESIGNATION	STANDARD NAVY STOCK NUMBER	MANUFAC- TURERS		TELETYPE PART NO.	ALL SYMBOL DESIGNATIONS INVOLVED	TOTAL NO. PER EQUIP.	SPARE PARTS			
					CODE	DESIG.				EQUIP.		STOCK	
										BOX	QUAN.	BOX	QUAN.
0-169	KEY LEVER: steel, nickel plated lever w/cellulose acetate butyrate (Tenite II) top; irregular shape, round keytop concave on top and tapered to point on bottom pressed on 1 end of lever; approx 2 1/4" lg x 1/2" diam keytop o/a, 0.042" thk material; mts by irregular shape elongated slot in lower end of lever; green keytop w/white characters "K, B"	Operates 0-332		N17-T-350014-186	CTT	151304	151304	0-169	1	-	-	-	-
0-170	KEY LEVER: steel, nickel plated lever w/cellulose acetate butyrate (Tenite II) top; irregular shape, round keytop concave on top and tapered to point on bottom pressed on 1 end of lever; approx 2 1/4" lg x 1/2" diam keytop o/a, 0.042" thk material; mts by irregular shape elongated slot in lower end of lever; green keytop w/white characters "I, F"	Operates 0-333		N17-T-350014-187	CTT	151305	151305	0-170	1	-	-	-	-
0-171	KEY LEVER: steel, nickel plated lever w/cellulose acetate butyrate (Tenite II) top; irregular shape, round keytop concave on top and tapered to point on bottom pressed on 1 end of lever; approx 2 1/4" lg x 1/2" diam keytop o/a, 0.042" thk material; mts by irregular shape elongated slot in lower end of lever; green keytop w/white characters "L, G"	Operates 0-334		N17-T-350014-228	CTT	151306	151306	0-171	1	-	-	-	-
0-172	KEY LEVER: steel, nickel plated lever w/cellulose acetate butyrate (Tenite II) top; irregular shape, round keytop concave on top and tapered to point on bottom pressed on 1 end of lever; approx 2 1/4" lg x 1/2" diam keytop o/a, 0.042 thk material; mts by irregular shape elongated slot in lower end of lever; green keytop w/white character "H"	Operates 0-335		N17-T-350014-229	CTT	151307	151307	0-172	1	-	-	-	-
0-173	KEY LEVER: steel, nickel plated lever w/cellulose acetate butyrate (Tenite II) top; irregular shape, round keytop concave on top and tapered to point on bottom pressed on 1 end of lever; approx 2 1/4" lg x 1/2" diam keytop o/a, 0.042" thk material; mts by irregular shape elongated slot in lower end of lever; green keytop w/white characters "I, J"	Operates 0-336		N17-T-350014-230	CTT	151308	151308	0-173	1	-	-	-	-

8-100

CHANGE 1

## PARTS LISTS

## NAVSHIPS 91393

TT-47/UG, TT-48/UG, TT-69/UG, TT-70/UG

Section 8  
O-174—O-179

0-174	KEY LEVER: steel, nickel plated lever w/cellulose acetate butyrate (Tenite II) top; irregular shape, round keytop concave on top and tapered to point on bottom pressed on 1 end of lever; approx 2 1/4" lg x 1/2" diam keytop o/a, 0.042" thk material; mts by irregular shape elongated slot in lower end of lever; green keytop w/white characters "(, K"	Operates 0-337	N17-T-350014-111	CTT	151309	151309	0-174	1	-	-	-	-	-
0-175	KEY LEVER: steel, nickel plated lever w/cellulose acetate butyrate (Tenite II) top; irregular shape, round keytop concave on top and tapered to point on bottom pressed on 1 end of lever; approx 2 1/4" lg x 1/2" diam keytop o/a, 0.042" thk material; mts by irregular shape elongated slot in lower end of lever; green keytop w/white characters ")", L"	Operates 0-338	N17-T-350014-110	CTT	151310	151310	0-175	1	-	-	-	-	-
0-176	KEY LEVER: steel, nickel plated lever w/cellulose acetate butyrate (Tenite II) top; irregular shape, round keytop concave on top and tapered to point on bottom pressed on 1 end of lever; approx 2 1/4" lg x 1/2" diam keytop o/a, 0.042" thk material; mts by irregular shape elongated slot in lower end of lever; green keytop w/white characters "CAR, RET"	Operates 0-339	N17-T-350014-109	CTT	151311	151311	0-176	1	-	-	-	-	-
0-177	KEY LEVER: steel, nickel plated lever w/cellulose acetate butyrate (Tenite II) top; irregular shape, round keytop concave on top and tapered to point on bottom pressed on 1 end of lever; approx 1 5/8" lg x 1 1/4" wd x 0.042" thk material o/a, 1/2" diam keytop; mts by irregular shape elongated slot in lower end of lever; green keytop w/white characters "FIGS"	Operates 0-340	N17-T-350014-108	CTT	151312	151312	0-177	1	-	-	-	-	-
0-178	KEY LEVER: steel, nickel plated lever w/cellulose acetate butyrate (Tenite II) top; irregular shape round keytop concave on top and tapered to point on bottom pressed on 1 end of lever; approx 1 5/8" lg x 1 1/4" wd x 0.042" thk material o/a, 1/2" diam keytop; mts by irregular shape elongated slot in lower end of lever; green keytop w/white characters "I, Z"	Operates 0-341	N17-T-350014-107	CTT	151313	151313	0-178	1	-	-	-	-	-
0-179	KEY LEVER: steel, nickel plated lever w/cellulose acetate butyrate (Tenite II) top; irregular shape, round keytop concave on top and tapered to point on bottom pressed on 1 end of lever; approx 1 5/8" lg x 1 1/4" wd x 0.042" thk material o/a, 1/2" diam keytop; mts by irregular shape elongated slot in lower end of lever; green keytop w/white characters "I, A"	Operates 0-342	N17-T-350014-106	CTT	151314	151314	0-179	1	-	-	-	-	-

CHANGE 1

8-101

TABLE 8-4. COMBINED PARTS AND SPARE PARTS LIST

SYMBOL DESIG.	NAME OF PART AND DESCRIPTION	FUNCTION	JAN OR NAVY TYPE DESIGNATION	PARTS				SPARE PARTS					
				STANDARD NAVY STOCK NUMBER	MANUFAC- TURERS		TELETYPE PART NO.	ALL SYMBOL DESIGNATIONS INVOLVED	TOTAL NO. PER EQUIP.	EQUIP.		STOCK	
					CODE	DESIG.				BOX	QUAN.	BOX	QUAN.
0-180	KEY LEVER: steel, nickel plated lever w/cellulose acetate butyrate (Tenite II) top; irregular shape, round keytop concave on top and tapered to point on bottom pressed on 1 end of lever; approx 1 5/8" lg x 1 1/4" wd x 0.042" thk material o/a, 1/2" diam keytop; mts by irregular shape elongated slot in lower end of lever; green keytop w/white characters ";, C"	Operates 0-343		N17-T-350014-105	CTT	151315	151315	0-180	1	-	-	-	-
0-181	KEY LEVER: steel, nickel plated lever w/cellulose acetate butyrate (Tenite II) top; irregular shape, round keytop concave on top and tapered to point on bottom pressed on 1 end of lever; approx 1 5/8" lg x 1 1/4" wd x 0.042" thk material o/a, 1/2" diam keytop; mts by irregular shape elongated slot in lower end of lever; green keytop w/white characters ";, V"	Operates 0-344		N17-T-350014-104	CTT	151316	151316	0-181	1	-	-	-	-
0-182	KEY LEVER: steel, nickel plated lever w/cellulose acetate butyrate (Tenite II) top; irregular shape, round keytop concave on top and tapered to point on bottom pressed on 1 end of lever; approx 1 5/8" lg x 1 1/4" wd x 0.042" thk material o/a, 1/2" diam keytop; mts by irregular shape elongated slot in lower end of lever; green keytop w/white characters ";, B"	Operates 0-345		N17-T-350014-103	CTT	151317	151317	0-182	1	-	-	-	-
0-183	KEY LEVER: steel, nickel plated lever w/cellulose acetate butyrate (Tenite II) top; irregular shape, round keytop concave on top and tapered to point on bottom pressed on 1 end of lever; approx 1 5/8" lg x 1 1/4" wd x 0.042" thk material o/a, 1/2" diam keytop; mts by irregular shape elongated slot in lower end of lever; green keytop w/white characters ";, M"	Operates 0-346		N17-T-350014-102	CTT	151318	151318	0-183	1	-	-	-	-
0-184	KEY LEVER: steel, nickel plated lever w/cellulose acetate butyrate (Tenite II) top; irregular shape, round keytop concave on top and tapered to point on bottom pressed on 1 end of lever; approx 1 5/8" lg x 1 1/4" wd x 0.042" thk material o/a, 1/2" diam keytop; mts by irregular shape elongated slot in lower end of lever; green keytop w/white characters "., M"	Operates 0-347		N17-T-350014-101	CTT	151319	151319	0-184	1	-	-	-	-

CHANGE 1

8-103

0-185	KEY LEVER: steel, nickel plated lever w/cellulose acetate butyrate (Tenite II) top; irregular shape, round keytop concave on top and tapered to point on bottom pressed on one end of lever; approx 1 5/8" lg w 1 1/4" wd x 0.042" thk material o/a, 1/2" diam keytop; mts by irregular shape elongated slot in lower end of lever; green keytop w/white characters "LTRS"	Operates 0-348	N17-T-350014-250	CTT	151320	151320	0-185	1	-	-	-	-	-
0-186	KEY LEVER: steel, nickel plated lever w/cellulose acetate butyrate (Tenite II) top; irregular shape, round keytop concave on top and tapered to point on bottom pressed on one end of lever; approx 1 5/8" lg x 1 1/4" wd x 0.042" thk material o/a, 1/2" diam keytop; mts by irregular shape elongated slot in lower end of lever; green keytop w/white characters "LINE FEED"	Operates 0-349	N17-T-350014-249	CTT	151321	151321	0-186	1	-	-	-	-	-
0-187	KEY LEVER: steel, nickel plated lever w/cellulose acetate butyrate (Tenite II) top; irregular shape, round keytop concave on top and tapered to point on bottom pressed on one end of lever; approx 1 5/8" lg x 1 1/4" wd x 0.042" thk material o/a, 1/2" diam keytop; mts by irregular shape elongated slot in lower end of lever; blank green key	Operates 0-350	N17-T-350014-248	CTT	151322	151322	0-187	1	-	-	-	-	-
0-192	PAWL: steel, nickel plated; irregular shape, round one end, squared cutout near other end, rounded ear formed at end on curve of body; approx 1 3/16" lg x 3/4" h x 3/32" wd o/a, 0.028" thk material; mts by hole in round end	Operates 0-141	N17-T-350014-429	CTT	151102	151102	0-192	1	-	-	-	-	-
0-193	GUIDE, code bar: steel, nickel plated; 13 elongated slots equally spaced one side, cut out both lower corners; approx 1 3/8" lg x 5/8" h x 0.028" thk o/a; mts by lower p/o body	Guide and stop for code bars	N17-T-350014-459	CTT	151101	151101	0-193	1	-	-	-	-	-
0-196	WASHER, felt: hard, white felt; round, 7/32" ID x 7/16" OD x 3/32" thk	Lubricates code levers	N17-T-350013-791	CTT	101796	101796	0-196, 0-242, 0-1575, 0-1578, 0-1927, 0-2042	12	1	2	-	-	-
0-198	Same as 0-148	Applies tension to code lever											
0-199	SEAL, noise: sirvene; irregular shape, raised ctr section w/42 projections; approx 8 5/8" lg x 9/16" h x 1" wd o/a; mts by back and rim around raised section	Noise seal	N17-T-350014-455	CTT	151094	151094	0-199	1	-	-	-	-	-
0-200	GUIDE, code lever: steel, nickel plated irregular shape, formed three sides, two rounded ears w/bushing welded to end ear; approx 9 3/4" lg x 1 1/8" h x 1 7/8" wd o/a, 0.035" thk material; mts by two large body holes ea end on base of guide; three large rectangular holes, 42 small holes in row and body hole in rounded ear on bottom, 42 narrow elongated slots, 42 small holes in row and one small elongated slot ea side, large irregular shaped hole and 13 body holes in formed end	Guide for 0-302 and 0-314 to 0-350	N17-T-350014-454	CTT	151093	151093	0-200	1	-	-	-	-	-

PARTS LISTS

NAVSHIPS 91393

TT-47/UG, TT-48/UG, TT-69/UG, TT-70/UG

Section 8  
0-185-0-200



TABLE 8-4. COMBINED PARTS AND SPARE PARTS LIST

PARTS										SPARE PARTS				
SYMBOL DESIG.	NAME OF PART AND DESCRIPTION	FUNCTION	JAN OR NAVY TYPE DESIGNATION	STANDARD NAVY STOCK NUMBER	MANUFACTURERS		TELETYPE PART NO.	ALL SYMBOL DESIGNATIONS INVOLVED	TOTAL NO. PER EQUIP.	EQUIP.		STOCK		
					CODE	DESIG.				BOX	QUAN.	BOX	QUAN.	
0-201	SPACER: steel, nickel plated; approx 1/2" OD x 3/8" ID x 1/4" lg o/a; mts by ID	Spaces 0-202 and 0-205		N17-T-350014-464	CTT	151126	151126	0-201	1	-	-	-	-	
0-202	GEAR: spur; steel, nickel plated; spiral teeth; RH; 48 teeth; 26 pitch, 1.92 PD; approx 2" OD x 3/8" ID x 9/16" thk o/a; straight face; hub 9/16" OD; mts by ID	Operates 0-1810		N17-T-350014-466	CTT	151129	151129	0-202	1	-	-	-	-	
0-203	BUSHING, eccentric: steel, nickel plated; male and female; approx 3/4" OD x 3/8" ID x 1/4" thk o/a; shoulder 9/16" diam x 1/16" thk and offset by 1/16"	Operates 0-126		N17-T-350013-696	CTT	151244	151244	0-203	1	-	-	-	-	
0-204	WASHER, felt: hard white felt; round, approx 1/8" thk x 1" OD x 3/4" ID o/a	Lubricates 0-203 and 0-202		N17-T-350013-697	CTT	151245	151245	0-204	1	1	1	-	-	
0-205	BEARING, ball: single row radial, light duty; approx 3/4" OD x 5/16" ID x 1/4" thk bearing pressed into approx 4" lg x 1 23/32" h x 1 15/16" wd o/a "U" shaped bracket; 8 balls; Teletype spec. 10049 grease; std fit; AFEMA spectol	Mounts 0-202		N17-T-350013-682	CTT	151228	151228	0-205	1	-	-	-	-	
0-206	BEARING, ball: single row radial; plain; medium duty; approx 3/8" bore x 7/8" OD x 7/32" wd; 8 balls; lubricated per Teletype spec. 15,041; standard fit; standard tolerance	Reduces friction on 0-207		N77-B-115-00609-0000	NORM. - HOFFMAN S-3R		104827	0-206	1	-	-	-	-	
0-207	SHAFT: steel, nickel plated; c/o head w/flange in middle, body, shoulder and shank; approx 2 1/8" lg x 1" OD o/a; mts by thd shank; flange has two tapped holes, tapped hole in body	Operates 0-202		N17-T-350014-465	CTT	151127	151127	0-207	1	-	-	-	-	
0-208	PLATE: steel, nickel plated; cutout one side, elongated slot one end, one elongated body hole and three tapped holes irregularly spaced; approx 4 7/16" lg x 2 1/4" wd x 0.095" thk o/a; mts by one tapped hole	Holds and locks 0-205 to keyboard base		N17-T-350014-710	CTT	151219	151219	0-208	1	-	-	-	-	
0-209	SHAFT: steel, nickel plated; approx 1 5/16" lg x 3/16" OD o/a; mts by two slots near one end	Pivot for 0-210		N17-T-350014-858	CTT	151112	151112	0-209, 0-217, 0-221	3	-	-	-	-	
0-210	ARM: steel, nickel plated; "U" shaped one end, formed once other end; approx 2 1/8" lg x 1" h x 1/2" wd o/a, 0.042" thk material; mts by two holes in line in sides of "U"; slot cut through bottom of "U" to mtg holes	Operates 0-2046		N17-T-350014-567	CTT	151108	151108	0-210	1	-	-	-	-	

CHANGE 1

8-105

0-211	ARM: steel, nickel plated; irregularly curved one end "U" formed, other end formed once; approx 3 7/8" lg x 7/8" h x 3/8" wd o/a, 0.042" thk; mts by two holes in line in sides of "U"; slots cut through bottom of "U" to mtg holes	Operates pivot action of 0-209	N17-T-350014-460	CTT	151109	151109	0-211, 0-222	2	-	-	-	-
0-212	PLATE, guide: steel, nickel plated; rectangular shape w/one side cut on angle near end; approx 1 7/16" lg x 5/16" wd x 0.065" thk o/a; mts by two tapped holes; body hole csk both sides at cut end	Guide for 0-213	N17-T-350014-462	CTT	151117	151117	0-212	1	-	-	-	-
0-213	PLUNGER: steel, nickel plated; irregular shape w/irregular shaped cutout; approx 1 1/2" lg x 7/16" h x 0.065" thk o/a; mts by elongated slot in round end	Operates 0-215	N17-T-350014-428	CTT	151115	151115	0-213	1	-	-	-	-
0-214	SPRING: helical extension type; 0.012" diam music wire; approx 9/16" lg x 5/32" OD x 1/8" ID o/a; approx 26 turns; parallel hook term ea end; mts by terms	Applies tension to 0-215	N17-T-350006-362	CTT	4703	4703	0-214, 0-767, 0-1405	13	1	3	-	-
0-215	ARM: steel, nickel plated; irregularly curved, one end "U" shaped, other end rounded; approx 1 5/8" lg x 1/2" h x 1/4" wd o/a, 0.042" thk material; mts by two holes in line in sides of "U"; slot cut through bottom of "U" to mtg holes, body hole and csk hole in near rounded end	Operates pivot action for 0-217	N17-T-350014-474	CTT	151148	151148	0-215	1	-	-	-	-
0-216	SPRING: flat; 0.022" thk nickel silver; approx 1 3/8" h x 1" lg x 5/16" wd o/a; mts by open slot curved end and closed slot straight end; "U" shaped w/formed ear at one end	Applies pressure to 0-213	N17-T-350013-711	CTT	151352	151352	0-216	1	-	-	-	-
0-217	Same as 0-209	Pivot for 0-218										
0-218	ARM: steel, nickel plated; irregular shape, "U" formed one end w/two cutouts, other end formed; approx 2 1/2" lg x 5/8" h x 1/4" wd o/a, 0.042" thk material; mts by two holes in line in sides of "U"; "U" slotted from bottom to mtg holes	Operates 0-314	N17-T-350014-490	CTT	151160	151160	0-218	1	-	-	-	-
0-219	LINK: steel, nickel plated; irregular shape, cutout on both sides, tapers up and formed one end, other end rounded, csk body hole in wd p/o body; approx 3 1/4" lg x 7/8" h x 1/2" wd o/a, 0.042" thk material; mts by body hole in rounded end	Operates 0-1724	N17-T-350013-894	CTT	151166	151166	0-219	1	-	-	-	-
0-220	SPRING: helical extension type; 0.018" diam music wire; approx 11/16" lg x 3/16" OD x 5/32" ID; approx 24 turns; hook term each end indexed 90°; mts by term	Applies tension to 0-219	N17-T-350006-301	CTT	112630	112630	0-220	1	1	2	-	-
0-221	Same as 0-209	Pivot for 0-223										
0-222	Same as 0-211	Operates pivot action of 0-221										

PARTS LISTS

TT-47/UG, TT-48/UG, TT-69/UG, TT-70/UG

NAVSHIPS 91393

Section 8  
O-211—O-222

TABLE 8-4. COMBINED PARTS AND SPARE PARTS LIST

SYMBOL DESIG.	NAME OF PART AND DESCRIPTION	FUNCTION	JAN OR NAVY TYPE DESIGNATION	STANDARD NAVY STOCK NUMBER	MANUFAC- TURERS		TELETYPE PART NO.	ALL SYMBOL DESIGNATIONS INVOLVED	SPARE PARTS				
					CODE	DESIG.			TOTAL NO. PER EQUIP.	EQUIP.		STOCK	
										BOX	QUAN.	BOX	QUAN.
0-223	ARM: steel, nickel plated; curved body w/rounded end and "U" shaped end; approx 2 1/8" lg x 7/8" h x 1/4" wd o/a, 0.042"thk material; mts by two holes in line in sides of "U"; slot cut through bottom of "U" to mtg holes, body hole in rounded end	Operates 0-219		N17-T-350014-426	CTT	151111	151111	0-223	1	-	-	-	-
0-224	BAR, space: cellulose acetate butyrate (Tenite II) w/aluminum extensions; irregular shape w/one elongated cutout in ctr and small cutout near ea end, extension mtd in ea end between small and large cutouts; approx 4 1/2" lg x 2" h x 1/2" wd o/a; mts by two holes in line at end of extensions	Operates 0-227		N17-T-350014-414	CTT	151045	151045	0-224	1	-	-	-	-
0-225	TOGGLE: steel, nickel plated; irregular shape, one end rounded, other end formed to hook; approx 2 9/16" lg x 3/4" wd x 3/8" h o/a, 0.050" thk material; mts by hole in rounded end; "V" shaped cutout on end of rectangular cutout and 2 tungsten points brazed on 2 ears at formed end	Mates and breaks with E-106		N17-T-350014-485	CTT	151171	151171	0-225	1	-	-	-	-
0-226	LEVER: steel, nickel plated; irregular shape w/ear one end and formed arm extending up other end, pin welded to lever near arm; approx 3/4" lg x 9/16" h x 3/16" wd o/a, 0.050" thk material; mts by elongated hole	Holds 0-231 in position		N17-T-350014-714	CTT	151078	151078	0-226	1	-	-	-	-
0-227	BALL: steel, nickel plated; narrow strip, formed both ends w/curved ear formed at end extending from side; approx 3 5/8" lg x 1 1/16" h x 11/16" wd o/a, 0.065" thk material; mts by two tapped holes in line and tapped hole in ear; two body holes in line	Operates 0-228		N17-T-350014-397	CTT	151013	151013	0-227	1	-	-	-	-
0-228	LINK: steel, nickel plated; irregularly curved w/round ends; approx 3 3/16" lg x 1/2" h x 0.050" thk o/a; mts by tapped hole in one end; body hole in end	Operates 0-234		N17-T-350014-398	CTT	151014	151014	0-228	1	-	-	-	-
0-229	RETAINER, wedge: steel, nickel plated; irregularly formed on bottom, 42 slots on top; approx 8 3/4" lg x 9/16" h x 1/8" wd o/a, 0.035" thk material; mts by body hole near top at ea end	Holds 0-230 in position		N17-T-350014-443	CTT	151081	151081	0-229	1	-	-	-	-
0-230	WEDGELOCK: steel, nickel plated; one end round other end pointed; approx 1/2" lg x 3/16" wd x 0.050" thk o/a; mts by body hole csk both sides in rounded ends	Operates locking action of 0-231		N17-T-350014-441	CTT	151076	151076	0-230	34	1	2	-	-

8-106

CHANGE 1

CHANGE 1

0-231	BALL, bearing: steel; spherical; approx 3/16" diam	Permits one key lever to operate at a time	N17-B-999-56012-0200	CTT	104710	104710	0-231	43	1	6	-	-
0-232	SPACER: steel, nickel plated; approx 1/4" OD x 1/8" ID x 1/16" lg o/a; mts by ID	Spacer for A-114 and A-116	N17-T-350013-706	CTT	151338	151338	0-232	4	-	-	-	-
0-233	STRIP: steel, nickel plated; lg narrow body w/wide ears at ea end; approx 15 1/16" lg x 1 5/16" h x 0.065" thk o/a; mts by elongated hole in ea end ear; 10 tapped holes	Locks A-114 to A-116	N17-T-350013-680	CTT	151226	151226	0-233	1	-	-	-	-
0-234	LEVER: steel, nickel plated; irregular shaped elongated cutout one end w/formed ear near end, other end rounded; approx 1 7/16" lg x 5/8" h x 1/8" wd o/a, 0.042" thk material; mts by hole in rounded end	Operates 0-302	N17-T-350014-432	CTT	151105	151105	0-234	1	-	-	-	-
0-235	SPRING: helical extension type; 0.014" diam music wire; approx 9/16" lg x 3/16" OD x 5/32" ID o/a; approx 21 turns; parallel hook term at end; mts by terms	Applies tension to 0-236	N17-T-350013-529	CTT	2836	2836	0-235	1	1	1	-	-
0-236	BAIL: steel, nickel plated; "U" shape one end w/one arm extending from bottom and one from side w/ear at end, other end formed; approx 1 1/2" lg x 15/16" h x 9/16" wd o/a, 0.050" thk material; mts by ID of bushing welded to side of "U" and hole in line on other side; csk hole in narrow arm, tapped hole in wd arm w/ear	Operates 0-237	N17-T-350014-572	CTT	151189	151189	0-236	1	-	-	-	-
0-237	LEVER: steel, nickel plated; irregular shape w/one formed end and two square ears on other end; approx 1 9/16" lg x 7/8" h x 1/4" wd o/a, 0.050" thk material; mts by large hole in rounded p/o body; small body hole below ears	Releases 0-266	N17-T-350014-580	CTT	151211	151211	0-237	1	1	1	-	-
0-238	WASHER, felt: hard, white felt; round, approx 1/16" thk x 3/4" OD x 7/16" ID o/a	Lubricates H-260 and 0-239	N17-T-350013-679	CTT	151225	151225	0-238	1	1	1	-	-
0-239	BAIL: steel, nickel plated; "U" shape w/4 arms irregularly shaped and formed, pawl bushing riveted to arm extending from bottom of "U"; approx 1 13/16" lg x 1 3/4" h x 1 1/16" wd o/a, 0.065 thk material; mts by 2 holes in line in sides of "U"; 2 csk holes and 1 body hole in arm	Operates 0-262	N17-T-350014-571	CTT	151187	151187	0-239	1	-	-	-	-
0-240	SPRING: helical extension type; 0.024" diam music wire; approx 15/16" lg x 7/32" OD x 3/16" ID o/a; approx 25 turns; 2 hook term; mts by term	Applies tension to 0-239	N17-T-350006-350	CTT	2416	2416	0-240	1	-	-	-	-

8-107

PARTS LISTS

TI-47/UG, TI-48/UG, TI-69/UG, TI-70/UG

NAVSHIPS 91393

Section 8  
O-231—O-240

TABLE 8-4. COMBINED PARTS AND SPARE PARTS LIST

SYMBOL DESIG.	NAME OF PART AND DESCRIPTION	FUNCTION	JAN OR NAVY TYPE DESIGNATION	STANDARD NAVY STOCK NUMBER	MANUFAC- TURERS		TELETYPE PART NO.	ALL SYMBOL DESIGNATIONS INVOLVED	SPARE PARTS										
					CODE	DESIG.			TOTAL NO. PER EQUIP.	EQUIP.		STOCK							
										BOX	QUAN.	BOX	QUAN.						
0-241	Same as 0-117	Applies tension to swivel action arm of 0-239																	
0-242	Same as 0-196	Lubricates H-260, 0-239 and 0-236																	
0-243	ROLLER, bail: steel; approx 3/16" OD x 1/16" ID x 1/16" thk o/a; mts by ID	Bearing for 0-260		N17-T- 350013- 897	CTT	151217	151217	0-243, 0-245	2	-	-	-	-						
0-244	SHAFT: steel; approx 1/4" lg x 3/32" diam o/a; c/o shank w/slot near end, narrow head, shoulder and body w/two slots	Mounts 0-243 and 0-245		N17-T- 350014- 582	TT	151215	151215	0-244	1	-	-	-	-						
0-245	Same as 0-243	Bearing for 0-260																	
0-246	DETENT: steel, nickel plated; irregular shape, rounded arm w/ck hole near rounded end, other end irregular shaped w/cutout and body hole; approx 1 3/16" lg x 5/8" wd x 0.050" thk o/a; mts by body hole in rounded end	Stop for 0-260 and mts 0-244		N17-T- 350013- 896	CTT	151216	151216	0-246	1	-	-	-	-						
0-247	Same as 0-148	Applies tension to 0-249																	
0-248	WASHER, felt: hard, white felt; round, 7/32" ID x 1/2" OD x 3/64" thk	Lubricates 0-249 and H-273		N17-T- 350013- 626	CTT	90679	90679	0-248, 0-1323, 0-2096, 0-2098	4	1	1	-	-						
0-249	LEVER: steel, nickel plated; irregular shape, formed one end, splits in two arms other end, hub welded in wd p/o body; approx 1 7/8" lg x 2 1/32" h x 1/2" wd o/a, 0.065" thk material; mts by ID of hub; csk hole in approx ctr of lever	Operates 0-257		N17-T- 350014- 893	CTT	151387	151387	0-249	1	-	-	-	-						
0-250	SPRING: helical extension type; 0.010" diam music wire; approx 5/8" lg x 1/8" OD x 3/32" ID o/a; approx 37 turns; hook term ea end indexed 90°; mts by terms	Applies tension to 0-251		N17-T- 350012- 236	CTT	110437	110437	0-250, 0-1652, 0-1656	3	1	3	-	-						
0-251	SLIDE, repeat: steel, chrome nickel; irreg shaped narrow body with two ends formed, formed ear on one side, curved arm on ea side; approx 2 1/8" lg x 7/8" h x 3/16" wd o/a, 0.035 thk material; mts by cutouts	Operates 0-249		N17-T- 350013- 717	CTT	151366	151366	0-251	1	-	-	-	-						
0-252	PLATE, guide: steel, nickel plated; one end round, elongated slot in other end; approx 7/16" lg x 1/4" wd x 0.035" thk o/a; mts by hole in rounded end	Guide for 0-275		N17-T- 350014- 409	CTT	151038	151038	0-252	1	-	-	-	-						

8-108

CHANGE 1

## PARTS LISTS

NAVSHIPS 91393

TT-47/UG, TT-48/UG, TT-69/UG, TT-70/UG

Section 8  
O-253—O-261

0-253	BEARING ASSEMBLY, roller: single row radial; light duty; cylindrical rollers; approx 5/32" shaft diam, 1/4" OD, 9/32" wd; lubricated and packed per Teletype spec; standard fit; retained, w/felt washer on shaft of 23/32" lg stud w/#6-40 thd one end, by retaining ring	Bearing for O-249	N17-T-350014-912	CTT	151388	151388	0-253	1	-	-	-	-	-
0-254	Same as O-125	Applies tension to O-257 and O-275											
0-255	WASHER, felt: hard, white felt; round, approx 7/16" OD x 1/4" ID x 1/8" thk o/a	Lubricates O-257 and H-281	N17-T-350003-322	CTT	93356	93356	0-255, 0-1316, 0-1319, 0-1537, 0-1549, 0-1697, 0-1709, 0-1710, 0-1715, 0-1728, 0-1729, 0-1733, 0-1740, 0-1833, 0-1916, 0-1929, 0-1932, 0-1937, 0-1939, 0-1941, 0-1956, 0-1959, 0-2029, 0-2049	36	1	5	-	-	-
0-256	SPRING: helical extension type; 0.012" diam music wire; approx 3/4" lg x 5/32" OD x 1/8" ID o/a; approx 37 turns; hook term ea end indexed 90°; mts by terms	Applies tension to O-257	N17-T-350013-622	CTT	86283	86283	0-256	1	1	1	-	-	-
0-257	BAIL: steel, nickel plated; irregular shape, formed all four sides w/two rounded arms extending up, one arm extending past side and rounded ear; approx 1 11/16" lg x 1 15/16" h x 7/8" wd o/a, 0.065" thk material; mts by two body holes in line and tapped hole in ear; body hole csk both side in ea rounded arm and body hole opposite side of mtg ear, large rectangular hole in ctr of bail	Releases and returns O-135 through O-140	N17-T-350014-437	CTT	151067	151067	0-257	1	-	-	-	-	-
0-259	EXTENSION, rocker: steel, nickel plated; "L" formed, one side irregularly curved, other side has body ear at end; approx 3/4" lg x 9/16" h x 7/16" wd o/a, 0.035" thk material; mts by one large and one small body hole on straight side of "L"	Operates O-290 and O-294	N17-T-350014-458	CTT	151099	151099	0-259	1	1	1	-	-	-
0-260	BAIL: steel, nickel plated; irregular shape, formed all four sides, irregular formed arm one side, two rounded ears in line, irregular shaped hole in ctr w/wing w/squared cutout one side formed down; approx 1 7/16" lg x 1 1/4" h x 1/2" wd o/a, 0.035" thk material; mts by two tapped holes in wing; two holes in line in rounded ears.	Operates O-259	N17-T-350014-436	CTT	151066	151066	0-260	1	-	-	-	-	-
0-261	PLATE: steel, nickel plated; approx 1 3/4" lg x 3/8" h x 0.083" thk o/a; mts by three tapped holes	Locks A-118 to keyboard	N17-T-350014-433	CTT	151106	151106	0-261	1	-	-	-	-	-

CHANGE 1

8-109

TABLE 8-4. COMBINED PARTS AND SPARE PARTS LIST

SYMBOL DESIG.	NAME OF PART AND DESCRIPTION	FUNCTION	JAN OR NAVY TYPE DESIGNATION	STANDARD NAVY STOCK NUMBER	MANUFAC- TURERS		TELETYPE PART NO.	ALL SYMBOL DESIGNATIONS INVOLVED	TOTAL NO. PER EQUIP.	SPARE PARTS			
					CODE	DESIG.				EQUIP.		STOCK	
										BOX	QUAN.	BOX	QUAN.
0-262	DISK: steel, nickel plated; irregular circular shape; approx 1 13/16" largest diam x 5/16" wd o/a, 0.065 thk material; mts by round ended slot in approx ctr; 3 cutouts and 1 formed ear on circum, five irregular shaped body holes, two tapped holes and two elongated slots in disk, one spring post riveted to disk	Operates 0-264.		N17-T-350014-608	CTT	150028	150028	0-262, 0-1753 0-1765, 0-1839	4	1	1	-	-
0-263	SPRING: helical extension type; 0.017" diam music wire; approx 13/16" lg x 1/8" OD o/a; approx 34 turns; hook terms, indexed 90°; mts by terms	Applies tension to 0-262		N17-T-350014-926	CTT	151728	151728	0-263, 0-1752, 0-1838, 0-1843	4	1	5	-	-
0-264	ARM: steel, nickel plated; irregular "C" shaped; approx 1 1/4" lg x 1 3/16" wd x 1/4" h o/a, 0.065" thk material; mts by two tapped holes; two cutouts and formed ear inside of "C", body ear one end of "C"	Adjusts 0-266 w/respect to 0-262		N17-T-350014-605	CTT	150013	150013	0-264, 0-1751, 0-1764, 0-1837	4	1	1	-	-
0-265	WICK: lubrication wick; hard, white felt; approx 5/8" lg x 9/32" wd x 1/32" thk o/a; slit in ctr, elongated arm tapered on end on one side of body	Lubricates clutch mechanism		N17-T-350013-813	CTT	150029	150029	0-265, 0-1748, 0-1763, 0-1779, 0-1792, 0-1818, 0-1836	7	1	2	-	-
0-266	LEVER: steel, nickel plated; irregular shape, 2 ears "U" formed one end, other end formed; approx 1 11/16" lg x 13/16" h x 7/32" wd o/a, 0.042" thk material; mts by "U" formed end; csk body hole in rise on lever	Operates 0-267 and 0-269		N17-T-350014-607	CTT	150026	150026	0-266, 0-1762, 0-1835	3	1	2	-	-
0-267	SHOE, clutch: steel; irregularly cutout on one edge, other edge straight w/heel near one end, irregularly dished out on both sides; approx 1 1/4" lg x 5/8" wd x 1/16" thk o/a; mts by cutout edge; one body hole csk both sides, primary shoe	Operates 0-276		N17-T-350014-749	CTT	150044	150044	0-267, 0-1747, 0-1760, 0-1774, 0-1794, 0-1815, 0-1832	7	1	1	-	-
0-268	SPRING: helical extension type; 0.018" diam music wire; approx 9/16" lg x 1/8" OD x 3/32" ID o/a; approx 17 turns; parallel hook term ea end	Applies tension to 0-267 and 0-269		N17-T-350014-618	CTT	150241	150241	0-268, 0-1750, 0-1759, 0-1776, 0-1796, 0-1816, 0-1834	7	1	4	-	-
0-269	SHOE, clutch: steel; irregularly cutout and notched on one edge, other edge straight w/heel at one end, irregularly dished out on both sides; approx 1 5/16" lg x 5/8" wd x 1/16" thk o/a; mts by cutout edge; one body hole csk both sides, secondary shoe	Operates 0-276		N17-T-350014-748	CTT	150043	150043	0-269, 0-1746, 0-1761, 0-1775, 0-1795, 0-1814, 0-1831	7	1	1	-	-

## PARTS LISTS

NAVSHIPS 91393  
TT-47/UG, TT-48/UG, TT-69/UG, TT-70/UGSection 8  
O-270—O-279

0-270	SLEEVE, gear: sleeve, oiling wick enclosed, with drum on one end and gear on other end; gear is super oilite, sleeve is steel, nickel plated and drum is cast iron; approx 4 13/16" lg x 1 5/8" OD x 5/16" ID o/a; mts by ID	Operates clutch mechanism	N17-T-350014-366	CTT	151154	151154	0-270	1	-	-	-	-	-
0-271	WASHER, felt: hard, white felt; round, approx 3/4" OD x 9/16" ID x 3/32" thk o/a	Lubricates 0-270	N17-T-350014-746	CTT	120824	120824	0-271	1	-	-	-	-	-
0-272	PLATE: steel, nickel plated; irregular shape w/round cut out on bottom; approx 1 5/8" lg x 1 3/16" h x 0.065" thk o/a; mts by two body holes in two lower corners; large body hole in rounded upper part	Mounts 0-274	N17-T-350014-425	CTT	151064	151064	0-272	1	-	-	-	-	-
0-273	WASHER, felt: hard, white felt, round, 1/2" ID x 11/16" OD x 1/16" thk	Lubricates H-314	N17-T-350012-719	CTT	72563	72563	0-273	1	1	1	-	-	-
0-274	SHAFT: steel; approx 7 5/8" lg x 5/16" diam o/a; mts by #10-32 threaded shank ea end	Mounts 0-270 and 0-276	N17-T-350014-493	CTT	151157	151157	0-274	1	-	-	-	-	-
0-275	FOLLOWER, eccentric: steel, nickel plated; irregular shape one end, other end large rounded; approx 3 3/4" lg x 1" wd x 0.095" thk o/a; mts by large hole in rounded end; body hole csk both sides in irregular shaped end	Operates 0-257	N17-T-350014-438	CTT	151068	151068	0-275	1	-	-	-	-	-
0-276	CAM ASSEMBLY: steel; eccentric cam and shield one end, other end cut flat on two sides w/ two slots and shield, 11 cams irregularly spaced and shaped between shields, bushing pressed in place ea end of ID; approx 2 1/4" lg x 1 1/16" OD x 5/16" ID o/a; mts by ID; two body holes in thicker shield	Operates 0-275 and selector levers	N17-T-350014-475	CTT	151151	151151	0-276	1	-	-	-	-	-
0-277	SPRING: helical extension type; 0.014" diam music wire; approx 1 7/8" lg x 1/8" OD x 3/32" ID; approx 118 turns; parallel hook term ea end; mts by term	Retains 0-278 to 0-276	N17-S-46762-1032	CTT	109631	109631	0-277	1	1	1	-	-	-
0-278	WICK: oil wick; hard, white felt; approx 2 1/8" lg x 5/16" wd x 1/16" thk o/a	Lubricates 0-276	N17-T-350013-704	CTT	151333	151333	0-278	1	-	-	-	-	-
0-279	PLATE: steel, nickel plated; irregular shape w/3 formed ears, 4 spring posts riveted to one side, 19 tapped holes, 4 body holes, 3 elongated slots and one rectangular hole, all holes and cutouts irregularly spaced; approx 3 7/8" lg x 2 3/4" h x 1 1/8" wd o/a, 0.065" thk material; mts by one elongated and one body hole	Mounts p/o signal generator mechanism	N17-T-350014-470	CTT	151140	151140	0-279	1	-	-	-	-	-

CHANGE 1

8-111



TABLE 8-4. COMBINED PARTS AND SPARE PARTS LIST

SYMBOL DESIG.	NAME OF PART AND DESCRIPTION	FUNCTION	JAN OR NAVY TYPE DESIGNATION	STANDARD NAVY STOCK NUMBER	MANUFAC- TURERS		TELETYPE PART NO.	ALL SYMBOL DESIGNATIONS INVOLVED	TOTAL NO. PER EQUIP.	SPARE PARTS			
					MFG CODE	DESIG.				EQUIP.		STOCK	
										BOX	QUAN.	BOX	QUAN.
0-280	LEVER: steel, nickel plated; irregular shape w/rounded ends, elongated formed ear extends down from larger end; approx 1" lg x 1/2" h x 1/4" wd o/a, 0.035" thk material; mts by ID of hub welded to large end; tapped hole in small end, body hole csk both sides in ear	Mounts and applies pressure to 0-281		N17-T-350014-401	CTT	151025	151025	0-280	1	-	-	-	-
0-281	TOGGLE, detent: steel, nickel plated; irreg shape w/round end and pointed end; approx 1/2" lg x 3/16" h x 0.032" thk o/a; mts by hole in rounded end	Operates 0-307		N17-T-350014-402	CTT	151026	151026	0-281	1	-	-	-	-
0-282	SPRING; helical extension type; 0.014" diam music wire; approx 21/32" lg x 5/32" OD o/a; approx 24 turns; parallel hook terminals; mts by terms	Applies tension to 0-283		N17-T-350006-330	CTT	125268	125268	0-282	1	-	-	-	-
0-283	LEVER: steel, nickel plated; irregular shape, formed one end, arm extending up rounded end, rounded ear in approx ctr; approx 1 1/2" lg x 5/8" h x 1/8" thk o/a, 0.042" thk material; mts by ID of hub welded to rounded end; hole csk both sides at end of arm	Operates 0-290 and 0-294		N17-T-350014-408	CTT	151037	151037	0-283	1	-	-	-	-
0-284	SPRING: helical extension type; 0.014" diam music wire; approx 21/32" lg x 5/32" OD x 1/8" ID o/a; approx 24 turns; parallel hook term ea end; mts by terms	Applies tension to 0-285		N17-T-350006-523	CTT	80581	80581	0-284, 0-1975, 0-2037	3	1	1	-	-
0-285	BAIL: steel, nickel plated; "U" formed one end w/one arm, other end irregular shape w/two ears and hub riveted between ears; approx 1" lg x 1" h x 1/4" wd o/a, 0.042" thk material; mts by two holes in line in sides of "U"; csk hole in end of arm	Operates 0-291		N17-T-350014-488	CTT	151164	151164	0-285	1	-	-	-	-
0-286	ROD, break: steel, nickel plated; bent in approx ctr, eye loop one end; approx 2 3/16" lg x 9/16" wd x 0.078" diam o/a; mts by straight end	Operates 0-285		N17-T-350014-583	CTT	151218	151218	0-286	1	-	-	-	-
0-287	SPRING: helical extension type; 0.018" diam music wire; approx 1/2" lg x 5/32" OD x 1/8" ID; approx 15 turns; parallel hook term each end; mts by terms	Applies tension to 0-280		N17-T-350003-956	CTT	101386	101386	0-287	1	1	1	-	-
0-288	WASHER, felt: hard, white felt; round, approx 5/16" OD x 1/8" ID x 1/8" thk o/a	Lubricates 0-281 and 0-291		N17-T-350005-822	CTT	93758	93758	0-288, 0-1302, 0-1705	4	1	3	-	-
0-289	SPRING; helical extension type; 0.013" diam music wire; approx 1/8" diam x 1/2" lg o/a; approx 18 turns; hook terminals indexed 90°; mts by terminals	Applies tension to 0-290		N17-S-46726-8131	CTT	151395	151395	0-289, 0-293	2	-	-	-	-

CHANGE 1

0-290	LEVER: steel, nickel plated; irregular shape w/two cutouts and two ears; approx 1 3/8" lg x 9/16" h x 0.031" thk o/a; mts by body hole csk both sides	Operates 0-291	N17-T-350014-415	CTT	151051	151051	0-290, 0-294	2	1	2	-	-
0-291	LEVER: steel, nickel plated; irregular shape, formed ear on ea side or rounded wing w/cutout below, "V" notched arm at one end; approx 1 1/8" lg x 7/16" h x 3/16" wd o/a, 0.032" thk material; mts by ID of hub welded to wing	Operates 0-281	N17-T-350014-573	CTT	151190	151190	0-291	1	-	-	-	-
0-292	PLATE: steel, nickel plated; one end formed; other end rounded, one body ear, stud riveted to plate; approx 15/16" lg x 3/16" h x 3/8" wd o/a, 0.035" thk material; mts by two elongated holes; two holes csk one side in formed end, stud has slot w/cutout	Positions 0-290 and 0-294, anchor for 0-289 and 0-293	N17-T-350014-577	CTT	151205	151205	0-292	1	-	-	-	-
0-293	Same as 0-289	Applies tension to 0-294										
0-294	Same as 0-290	Operates 0-291										
0-295	WASHER, felt; hard, white felt; round approx 1/16" thk x 7/16" OD x 3/16" ID o/a	Lubricates 0-297 and H-357	N17-T-350013-676	CTT	151222	151222	0-295, 0-369, 0-1938, 0-2116	5	1	1	-	-
0-296	SPRING: helical extension type; 0.016" diam music wire; approx 11/16" lg x 5/32" OD x 1/8" ID o/a; approx 27 turns; parallel hook term ea end; mts by terms	Applies tension to 0-297	N17-T-350013-627	CTT	90573	90573	0-296	1	-	-	-	-
0-297	BAIL: steel, nickel plated; irregular shape, 3 formed sides, 1 lg round arm and elongated formed ear; approx 1 3/8" lg x 5/16" h x 1 3/8" wd o/a, 0.035" thk material; mts by 2 holes in line; small body hole in formed ear	Stops and releases 0-358 to 0-364	N17-T-350014-435	CTT	151065	151065	0-297	1	-	-	-	-
0-298	SHAFT: steel, nickel plated; approx 1 1/16" lg x 1/8" OD o/a; mts by 2 slots 1/64" dp x 1/64" wd, 3/64" apart and 1/32" from one end, 1/64" chamfer both ends	Stop for 0-351 to 0-357	N17-T-350014-871	CTT	151097	151097	0-298	1	-	-	-	-
0-299	SPRING: helical extension type; 0.009" diam music wire; approx 23/32" lg x 3/32" diam o/a; 62 turns; hook terminals indexed 90°; mts by terminals	Applies tension to selector lever	N17-S-46761-6791	CTT	151397	151397	0-299	7	1	7	-	-
0-301	GUIDE, selector: steel, nickel plated; side has 2 elongated and 1 round hole, body has 8 slots, 1 large cutout and 8 small holes csk both sides, formed ear has body hole at end; approx 1 1/16" lg x 5/8" wd x 1" h o/a, 0.035" thk material; mts by 2 elongated holes	Guide for 0-351 to 0-357	N17-T-350014-492	CTT	151158	151158	0-301	1	-	-	-	-

PARTS LISTS

TT-47/UG, TT-48/UG, TT-69/UG, TT-70/UG

NAVSHIPS 91393

Section 8  
0-290—0-301

8-113

8-114

TABLE 8-4. COMBINED PARTS AND SPARE PARTS LIST

SYMBOL DESIG.	NAME OF PART AND DESCRIPTION	FUNCTION	JAN OR NAVY TYPE DESIGNATION	PARTS				SPARE PARTS					
				STANDARD NAVY STOCK NUMBER	MANUFACTURERS		TELETYPE PART NO.	ALL SYMBOL DESIGNATIONS INVOLVED	TOTAL NO. PER EQUIP.	EQUIP.		STOCK	
					CODE	DESIG.				BOX	QUAN.	BOX	QUAN.
0-302	LEVER: steel, nickel plated; irregular shape w/2 elongated ears and 1 narrow elongated cutout, stud welded near cutout; approx 4 5/8" lg x 5/8" h x 1/8" wd o/a, 0.042" thk material; mts by large body hole near cutout; body hole csk both sides near mtg hole	Operates 0-134 and positions 0-135 to 0-140		N17-T-350014-564	CTT	151007	151007	0-302	1	-	-	-	-
0-303	Same as 0-142	Guide for 0-135 to 0-141											
0-304	LINK, toggle: steel, nickel plated; irregular shape w/ear on ea end; approx 1 1/16" lg x 5/16" h x 5/16" wd o/a, 0.042" thk material; mts by ears; formed both ends, 2 body holes	Applies pressure to and guides 0-225		N17-T-350014-479	CTT	151180	151180	0-304	1	1	1	-	-
0-305	SPRING: helical extension type; 0.020" diam music wire; approx 3/4" lg x 1/8" OD o/a; approx 25 turns; hook terms, indexed 90°; mts by terms	Applies tension to 0-304 and E-107		N17-T-350014-885	CTT	151820	151820	0-305	1	1	1	-	-
0-306	GUIDE: steel, nickel plated; "L" shaped; approx 9/16" lg x 11/32" h x 11/32" wd o/a, 0.035" thk material; mts by 2 tapped body holes; rectangular cutout on side	Guides 0-307		N17-T-350014-569	CTT	151185	151185	0-306	1	-	-	-	-
0-307	EXTENSION, toggle: steel, nickel plated; irregular shape w/1 curved and 1 hook shaped end; approx 1 7/16" lg x 9/32" h x 0.042" thk o/a; mts by tapped hole in 1 end and hook section on other end; 2 elongated cutouts on 1 side	Operates 0-225		N17-T-350014-568	CTT	151184	151184	0-307	1	-	-	-	-
0-308	WASHER, felt: hard, white felt; round, approx 5/16" OD x 1/8" ID x 1/16" thk o/a	Lubricates 0-313 and 0-312		N17-T-350012-728	CTT	86079	86079	0-308, 0-1556	3	1	3	-	-
0-311	SPRING: helical extension type; 0.009" diam music wire; approx 5/16" lg x 3/32" diam o/a; approx 14 turns; hook terminals indexed 90°; mts by terminals	Applies tension to transfer lever		N17-S-46718-7051	CTT	151398	151398	0-311	7	1	7	-	-
0-312	GUIDE, lever: steel, nickel plated; both ends formed wing on both sides, 8 body holes and 3 cutouts w/8 slots 1 end, 8 slots in other end, 8 slots and 1 rectangular shaped hole in body, 3 body holes in larger wing; approx 1 11/16" lg x 1 1/32" wd x 7/8" h o/a, 0.035" thk material; mts by 2 holes in line in formed wings	Guide for 0-351 to 0-364		N17-T-350014-168	CTT	151188	151188	0-312	1	-	-	-	-

CHANGE 1

8 Section  
0-302-0-312TT-47/UG, TT-48/UG, TT-69/UG, TT-70/UG  
NAVSHPIS 91393

PARTS LISTS

CHANGE 1

8-115

0-313	SHAFT: steel, nickel plated; approx 1/8" diam x 1 1/8" lg o/a; mts by 2 grooves near 1 end	Stop for 0-358 to 0-364	N17-T-350014-489	CTT	151161	151161	0-313	1	-	-	-	-	-
0-314	LEVER, function: steel, nickel plated; irregular shape w/stud riveted to "pear" shaped end, "V" notch in wd p/o body; approx 5 1/16" lg x 3/4" h x 1/8" wd o/a, 0.042" thk material; mts by large hole near ctr; body hole csk both sides near mtg hole	Operates 0-192	N17-T-350014-706	CTT	151337	151337	0-314, 0-315, 0-316, 0-317	4	-	-	-	-	-
0-315	Same as 0-314	Operates 0-141											
0-316	Same as 0-314	Operates 0-286											
0-317	Same as 0-314	Operates 0-251 and positions 0-135 to 0-140											
0-318	LEVER: steel, nickel plated; irregular shape w/elongated ear and "V" notch, stud welded to "pear" shaped end; approx 5 1/16" lg x 3/4" h x 1/8" wd o/a, 0.042" thk material; mts by large body hole in approx ctr; body hole csk both sides near mtg hole	Operates 0-222	N17-T-350014-566	CTT	151049	151049	0-318, 0-319	2	-	-	-	-	-
0-319	Same as 0-318	Operates 0-211											
0-320	LEVER: steel, nickel plated; irregular shape w/2 elongated ears and 1 "V" notch, stud welded to small end; approx 5 3/4" lg x 3/4" h x 1/8" wd o/a, 0.042" thk material; mts by large body hole near ctr; body hole csk both sides in approx ctr	Sets up code for Character W	N17-T-350014-563	CTT	151001	151001	0-320 through 0-350	31	-	-	-	-	-
0-321	Same as 0-320	Sets up code for Character Q											
0-322	Same as 0-320	Sets up code for Character E											
0-323	Same as 0-320	Sets up code for Character R											
0-324	Same as 0-320	Sets up code for Character T											
0-325	Same as 0-320	Sets up code for Character Y											
0-326	Same as 0-320	Sets up code for Character U											
0-327	Same as 0-320	Sets up code for Character I											
0-328	Same as 0-320	Sets up code for Character O											
0-329	Same as 0-320	Sets up code for Character P											
0-330	Same as 0-320	Sets up code for Character A											
0-331	Same as 0-320	Sets up code for Character S											
0-332	Same as 0-320	Sets up code for Character D											
0-333	Same as 0-320	Sets up code for Character F											
0-334	Same as 0-320	Sets up code for Character G											
0-335	Same as 0-320	Sets up code for Character H											

PARTS LISTS

TT-47/UG, TT-48/UG, TT-69/UG, TT-70/UG

NAVSHIPS 91393

O-313-O-335

Section 8

8-116

TABLE 8-4. COMBINED PARTS AND SPARE PARTS LIST

SYMBOL DESIG.	NAME OF PART AND DESCRIPTION	FUNCTION	JAN OR NAVY TYPE DESIGNATION	STANDARD NAVY STOCK NUMBER	MANUFACTURERS		TELETYPE PART NO.	ALL SYMBOL DESIGNATIONS INVOLVED	TOTAL NO. PER EQUIP.	SPARE PARTS				
					CODE	DESIG.				EQUIP.		STOCK		
										BOX	QUAN.	BOX	QUAN.	
0-336	Same as 0-320	Sets up code for Character J												
0-337	Same as 0-320	Sets up code for Character K												
0-338	Same as 0-320	Sets up code for Character L												
0-339	Same as 0-320	Sets up code for Carriage Return												
0-340	Same as 0-320	Sets up code for Figs Shift												
0-341	Same as 0-320	Sets up code for Character Z												
0-342	Same as 0-320	Sets up code for Character X												
0-343	Same as 0-320	Sets up code for Character C												
0-344	Same as 0-320	Sets up code for Character V												
0-345	Same as 0-320	Sets up code for Character B												
0-346	Same as 0-320	Sets up code for Character N												
0-347	Same as 0-320	Sets up code for Character M												
0-348	Same as 0-320	Sets up code for Ltrs Shift												
0-349	Same as 0-320	Sets up code for Line Feed												
0-350	Same as 0-320	Sets up code for Blank												
0-351	LEVER: steel, nickel plated; irregular shape w/3 body ears; approx 2 3/4" lg x 7/16" h x 0.042" thk o/a; mts by irregular shaped hook end and body hole csk both sides on other end	Operates 0-260		N17-T- 350014- 416	CTT	151052	151052	0-351 through 0-357	7	-	-	-	-	-
0-352	Same as 0-351	Operates 0-260												
0-353	Same as 0-351	Operates 0-260												
0-354	Same as 0-351	Operates 0-260												
0-355	Same as 0-351	Operates 0-260												
0-356	Same as 0-351	Operates 0-260												
0-357	Same as 0-351	Operates 0-260												
0-358	LEVER: steel, nickel plated; irregular shape w/2 cutouts, pointed ear 1 end, thickened section other end; approx 2 1/16" lg x 7/16" h x 5/64" wd o/a, 0.042" thk material; mts by irregular shaped cutout near pointed ear; body hole csk both sides near thk end	Positions 0-351		N17-T- 350014- 417	CTT	151053	151053	0-358 through 0-364	7	-	-	-	-	-

CHANGE 1

8 Section  
O-336-O-358NAVSHIPS 91393  
TT-47/UG, TT-48/UG, TT-69/UG, TT-70/UG

PARTS LISTS

0-359	Same as 0-358	Positions 0-352																		
0-360	Same as 0-358	Positions 0-353																		
0-361	Same as 0-358	Positions 0-354																		
0-362	Same as 0-358	Positions 0-355																		
0-363	Same as 0-358	Positions 0-356																		
0-364	Same as 0-358	Positions 0-357																		
0-365	SHIM: steel; approx 5/16" OD x 3/16" ID x 0.004" thk o/a	Cushion for A-107				CTT	7654	7654	0-365	8	-	-	-	-	-	-	-	-	-	-
0-366	LINK: steel, nickel plated; cutout one side, rounded ends; approx 1 5/32" lg x 5/16" wd x 0.042" thk o/a; mts by body hole in ea end	Braces 0-312				N17-T-350014-901	CTT	151831	151831	0-366	1	-	-	-	-	-	-	-	-	-
0-367	BAR, upstop: steel, nickel plated; approx 8 13/16" lg x 1/2" wd x 0.035" thk o/a; mts by ends; 3 cutouts one side, one lg cutout w/tooth in other side, body hole near one end	Upstop for 0-314 through 0-319					CTT	151830	151830	0-367	1	-	-	-	-	-	-	-	-	-
0-368	Same as 0-147	Applies tension to 0-367																		
0-369	Same as 0-295	Lubricates 0-291																		
0-501	STATOR, motor: steel, cadmium plated shell; approx 4 1/8" lg x 3 3/4" OD x 2" ID o/a; mts by rims at both ends and 2 body holes through stator core; 12 elongated slots and body hole w/raised rim 1 end, 13 elongated slots other end	Operates E-501				N17-T-350013-808	CG	111B402 AA-G1	122251	0-501	1	-	-	-	-	-	-	-	-	-
0-502	SPRING: motor type; 0.086" diam steel wire; approx 1/2" lg x 1 1/8" OD x 5/8" ID o/a; 3 turns; sq ends; coil diam increased from first to last	Applies pressure to E-501				N17-T-350007-593	CG	3536317	71999	0-502, 0-611	2	-	-	-	-	-	-	-	-	-
0-503	END-BELL: steel; irregular shape front w/4 irregular shaped holes and boss on lower half, 2 rounded ears w/ball oiler at end and body hole in upper half, 3 arms irregularly spaced w/tapped hole at ends, back irregular shaped w/baffle, vibration mount extends in front; approx 3 7/8" OD x 7/16" ID x 1 1/2" lg o/a; mts by 2 elongated holes near circum	End bell for 0-501 and mounts S-502				N17-E-39047-6101	CG	111B800 AA-G1	122198	0-503	1	-	-	-	-	-	-	-	-	-
0-504	END-BELL: irregular shape, front has 4 irregular shaped holes and boss on lower half, 2 rounded rises w/ball oiler at end in upper half, vibration mount extends in front, back irregular shape w/baffle; approx 3 7/8" OD x 7/16" ID x 1 3/8" lg o/a; mts by body hole in ea of two depressions	End bell for 0-501				N17-E-39047-4401	CG	111B802 AA-G1	122252	0-504, 0-512	2	-	-	-	-	-	-	-	-	-
0-505	GEAR: spur; natural color bakelite; helical teeth; RH; 96 teeth; 30 pitch, 3.50 PD; approx 3 9/16" OD x 1/2" ID x 5/16" thk o/a; concave face; mts by ID and 2 body holes; "151131" stamped on face	Operates MX-1115/UG at 60 W.p.m.				N17-T-350014-468	CTT	151131	151131	0-505	1	-	-	-	-	-	-	-	-	-

TABLE 8-4. COMBINED PARTS AND SPARE PARTS L 5T

SYMBOL DESIG.	NAME OF PART AND DESCRIPTION	FUNCTION	JAN OR NAVY TYPE DESIGNATION	STANDARD NAVY STOCK NUMBER	MANUFACTURERS		TELETYPE PART NO.	ALL SYMBOL DESIGNATIONS INVOLVED	TOTAL NO. PER EQUIP.	SPARE PARTS			
					CODE	DESIG.				EQUIP.		STOCK	
										BOX	QUAN.	BOX	QUAN.
0-506	GEAR: spur; natural color bakelite; helical teeth; RH; 84 teeth; 28 pitch, 3.24 PD; approx 3 5/16" OD x 1/2" ID x 5/16" thk o/a; concave face; mts by ID and 2 body holes; "151135" stamped on face	Operates MX-1115/UG at 100 w.p.m. through 0-207		N17-T-350014-469	CTT	151135	151135	0-506	1	-	-	-	-
0-507	GEAR: spur; steel; helical teeth; LH; 14 teeth; 30 pitch, 0.51" PD; approx 9/16" OD x 3/8" ID x 1 1/16" lg o/a; straight face; hub 17/32" diam x 9/16" lg; mts by ID and ctb hole in hub; "151130" stamped on hub	Operates 0-505		N17-T-350014-467	CTT	151130	151130	0-507	1	-	-	-	-
0-508	GEAR: spur; steel; helical teeth; LH; 20 teeth; 28 pitch, 0.77" PD; approx 27/32" OD x 3/8" ID x 1 1/16" lg o/a; straight face; hub 9/16" lg x 17/32" ID; mts by hub and ctb body hole; "151134" stamped on hub	Operates 0-506		N17-T-350014-439	CTT	151134	151134	0-508	1	-	-	-	-
0-509	BUSHING: steel, nickel plated; tapped hole near ea end; approx 3 1/4" lg x 15/32" wd x 1/8" thk o/a; mts by tapped hole in ctr	Nut plate for PD-17/U, PD-17A/U or PD-18/U		N17-T-350014-427	CTT	151113	151113	0-509	2	-	-	-	-
0-510	BEARING, ball: single row radial; single shield; light duty; 0.3937" bore, 1.1811" OD, 0.3543" wd; 7 balls; packed w/beacon 325 grease; std fit; ABEC-1 std tol	Rotor bearing for 0-504		N77-B-111-01002-1000	CG	585292 2AA7	122201	0-510, 0-511, 0-618, 0-619	4	-	-	-	-
0-511	Same as 0-510	Rotor bearing for 0-503											
0-512	Same as 0-504	End bell for 0-501											
0-601	SPRING: torsion type; 0.022" diam music wire; approx 1" lg x 1/8" h x 3/8" wd o/a; 4 turns; right hand turns; ends extended, one curved; mts by ends	Applies tension to E-602		N17-T-350014-385	CTT	150880	150880	0-601	1	1	1	-	-
0-602	SPRING: torsion type; 0.022" diam music wire; approx 1" lg x 1/8" h x 3/8" wd o/a; 4 turns; left hand turns; ends extended, one curved; mts by ends	Applies tension to E-601		N17-T-350014-313	CTT	150881	150881	0-602	1	1	1	-	-
0-603	SPACER: steel, nickel plated; approx 3/8" lg x 5/16" OD x 1/8" ID o/a; mts by ID	Spaces A-606 on one side from 0-610		N17-T-350014-382	CTT	150873	150873	0-603	1	-	-	-	-
0-604	SPRING: helical extension type; 0.051" diam music wire; approx 1 1/4" lg x 1/2" OD x 3/8" ID o/a; approx 23 turns; mts by tapped hole in anchor soldered to ea end	Applies tension to E-606		N17-T-350014-380	CTT	150869	150869	0-604	1	-	-	-	-
0-608	BUSHING: adjustment setting for contact; bakelite; male and female; approx 5/8" lg x 3/8" OD x 1/8" ID, ID 1/16" off ctr	Stop adjustment for E-606		N17-T-350014-373	CTT	150853	150853	0-608	1	-	-	-	-

0-609	CAP: brass w/bakelite insulator; 3/4" - 24 external thd one half length, knurled other half, slot in ctr; approx 5/16" lg x 3/4" OD o/a, 5/8" ID in threaded end only; mts by threaded portion; bakelite disk inserted inside cap	Retains E-607 or E-608 in H-682	N17-T-350013-803	CG	5899879-1	122204	0-609	2	-	-	-	-
0-610	END-BELL: steel; irregular shape, 3 irregular shape holes, 3 bosses, vibration mt, 2 cut-outs and 2 grommets in front end, 2 internal rises on rear end, 2 ball oilers on side; approx 2 9/16" lg x 3 7/8" OD x 3/8" ID o/a; mts by 2 tapped holes in rear end; 12 tapped holes and 3 body holes irregularly located	End bell for O-614 and mounts A-606, A-609, H-682 and part of series circuit	N17-E-39048-1001	CG	8736222AA1	122200	0-610	1	-	-	-	-
0-611	Same as O-502	Applies pressure to E-609										
0-614	STATOR, motor: steel, cadmium plated shell; two windings in ID; approx 3 1/8" lg x 3 7/8" OD x 2 5/8" ID o/a; mts by rims and two body holes through core	Operates E-609	N17-T-350014-515	CTT	122221	122221	0-614	1	-	-	-	-
0-615	END-BELL: irregular shape, front has four irregular shaped holes and boss on lower half vibration mt extends in front, electrostatic shield w/#40 brass screen on back; approx 3 3/16" OD x 7/16" ID x 1 3/16" wd o/a; mts by elongated hole in ea of 2 opposite cut-outs; body hole near ID	End bell for E-614	N17-E-39047-4501	CG	111C802AB-G1	122253	0-615	1	-	-	-	-
0-618	Same as O-510	Rotor bearing for O-610										
0-619	Same as O-510	Rotor bearing for O-615										
0-620	SPRING: flat type; 0.010" thk nickel silver; approx 1 3/4" lg x 5/8" wd x 1/4" h o/a; 5 equally spaced ripples	Applies pressure to and spaces C-602 and Z-601		CTT	152078	152078	0-620	1	-	-	-	-
SYMBOL DESIGNATIONS O-751 TO O-771 INCL USED ON CY-870/UG AND CY871/UG CABINETS												
0-751	GASKET: cabinet dome; black neoprene sponge rubber; approx 65" lg (spliced to form circle) x 7/16" h x 3/16" thk	Noise seal for dome	# N17-T-350014-760	CTT	151505	151505	0-751	2	-	-	-	-
0-752	GASKET: black neoprene sponge rubber; irregular shape, approx 35" lg w/ 5/16" base, one side 9/32" h, other side 1/8" h; slot in center entire length	Noise seal for dome	# N17-T-350014-759	CTT	151504	151504	0-752	1	-	-	-	-
0-754	SHIELD, light: nickel silver; "U" formed spring clamp welded on ea end of a narrow slightly curved strip; approx 8 1/4" lg x 1 1/16" wd x 7/8" h; mts by spring clamps	Shield for E-751 and E-752	# N17-T-350014-898	CTT	151983	151983	0-754	1	-	-	-	-

# 0-751 to O-754 used on CY-870/UG and CY-871/UG

CHANGE 1

8-119



TABLE 8-4. COMBINED PARTS AND SPARE PARTS LIST

SYMBOL DESIG.	NAME OF PART AND DESCRIPTION	FUNCTION	JAN OR NAVY TYPE DESIGNATION	STANDARD NAVY STOCK NUMBER	MANUFACTURERS		TELETYPE PART NO.	ALL SYMBOL DESIGNATIONS INVOLVED	TOTAL NO. PER EQUIP.	SPARE PARTS			
					CODE	DESIG.				EQUIP.		STOCK	
										BOX	QUAN.	BOX	QUAN.
0-755	SPRING: torsion type; 0.067" diam music wire; approx 1 1/16" lg x 11/16" wd x 7/16" h o/a; approx 9 turns; LH turns; one hook and one straight term; straight ends, mts by terms	Applies pressure to dome lid		# N17-T-350014-587	CTT	151538	151538	0-755	2	1	2	-	-
0-756	ARM: steel, nickel plated; irregular shape, one end curved, irregular shaped cutout near other end; approx 8" lg x 3/4" wd x 0.062" thk o/a; mts by hole near curved end	Supports MX 1114/UG up at angle		# N17-T-350014-764	CTT	151519	151519	0-756	1	-	-	-	-
0-759	SPRING: helical compression type; 0.026" diam music wire; approx 3/8" lg x 1/4" OD x 3/16" ID o/a; 4 turns; flat ends; mts on ID	Applies pressure to 0-760		# N17-T-350014-774	CTT	151548	151548	0-759	2	-	-	-	-
0-760	COPYHOLDER: stainless steel; approx 12" lg x 2 3/4" h x 7/16" wd o/a, material 0.050" thk; mts by slots in formed up ears at ea end of base; "TELETYPE" etched in 1/4" characters on base and filled with gray lacquer; top formed over, center cutout 2 1/4" h x 11 1/8" lg	Holds copy to cabinet dome		# N17-T-350014-771	CTT	151537	151537	0-760	1	-	-	-	-
0-761	SPRING: helical extension type; 0.024" diam music wire; approx 7/32" OD x 1 7/32" lg o/a; 34 turns; hook terminals; straight ends; mts by terms	Applies tension to dome latch		# N17-T-350006-455	CTT	74712	74712	0-761	4	1	2	-	-
0-762	ARM: steel, nickel plated; c/o two irregularly formed arms riveted together; approx 5" lg x 7/16" wd x 5/8" h o/a; mts by body hole on ea end	Holds dome lid open		# N17-T-350014-781	CTT	151576	151576	0-762	1	-	-	-	-
0-763	SPRING: torsion type; 0.045" diam music wire, approx 2 1/16" lg x 1/2" h x 1 3/8" wd o/a; 5 turns; RH turns; 2 hook term; straight ends; mts by terms	Applies pressure to 0-762		# N17-T-350014-863	CTT	151547	151547	0-763	1	1	1	-	-
0-765	SPRING: torsion type; 0.045" diam music wire; approx 2 1/16" lg x 3/4" h x 7/32" wd o/a; 1 turn; RH turn; one hook and one straight term; straight ends; mts by term	Applies pressure to 0-762		# N17-T-350014-586	CTT	151528	151528	0-765	1	1	1	-	-
0-766	ARM: steel, nickel plated; c/o two arms riveted together, formed end of one fits in cutout of other, other ends curved; approx 10 1/8" lg x 7/16" wd x 3/8" h o/a, 0.095" thk material; mts by hole at ea end	Holds cabinet dome open		# N17-T-350014-780	CTT	151575	151575	0-766	1	-	-	-	-
0-767	Same as 0-214	Applies tension to dome latch											
0-768	BUSHING: steel, nickel plated; male and female; approx 1/8" lg x 3/8" OD x 5/32" ID o/a, 3/16" diam shoulder	Bushing for I-752		# N17-T-350014-778	CTT	151565	151565	0-768	1	-	-	-	-

8-120

CHANGE 1

CHANGE 1

0-769	PAD, silencing; fiber glass; approx 8" lg x 6" wd x 1" thk o/a	Silencing pad	# N17-T-350014-768	DWENS-CORNING PP-316- 1 lb density	151533	0-769	3	-	-	-	-	-
0-770	SHAFT: steel, nickel plated; c/o shaft w/two pronged formed arms welded to cutout near head end, cut out on other end; approx 14 7/8" lg x 1/2" wd x 1" h o/a; mts by slot and cut-outs at ends	Operates S-1103	# N17-T-350014-772	CTT	151541	151541	0-770	1	-	-	-	-
0-771	SPRING: helical extension type; 0.040" diam music wire; approx 1" lg x 3/8" OD x 9/32" ID o/a; approx 10 turns; hook term on ea end; mts by terms	Applies tension to 0-770	# N17-S-46710-9634	CTT	151559	151559	0-771	1	1	1	-	-
0-1101	PLATE: aluminum, plain anodized; approx 4 9/16" lg x 2 7/8" wd x 0.064" thk o/a; mts by body hole at both ends; seven body holes and one elongated cutout rounded at end	Mounts H-1105 and A-1108 to A-1101	N17-T-350013-732	CTT	151423	151423	0-1101	1	-	-	-	-
0-1102	PLATE: aluminum, plain anodized; formed on four sides, small cutout on ea corner; approx 4 13/16" lg x 3 3/4" wd x 3/8" h o/a, 0.064" thk material; mts by two elongated slots near ends	Cover for A-1101 and spaces A-1105 and 0-1101	N17-T-350014-246	CTT	151426	151426	0-1102	1	-	-	-	-
0-1103	PLATE: aluminum, plain anodized; formed on four sides, small cutout on each corner, 14 irregular spaced body holes; approx 4 13/16" lg x 2 3/4" wd x 3/8" h o/a, 0.064" thk material; mts by two elongated slots	Cover for A-1101 and spaces A-1105 and 0-1104	N17-T-350014-245	CTT	151441	151441	0-1103	1	-	-	-	-
0-1104	PLATE: aluminum, plain anodized; approx 4 9/16" lg x 2 3/4" wd x 0.064" thk o/a; mts by body hole near ea end; 1/8" h characters "ON, MAINT. ON, OFF LIGHT"; eight round body holes, one w/tooth and two w/flat section, one rectangular body hole and one cutout rounded at end	Mounts H-1105, S-1102, J-1103, XF-1101 and XF-1102 to A-1101	N17-T-350013-731	CTT	151421	151421	0-1104	1	-	-	-	-
0-1105	CLIP: retainer; nickel silver; approx 1" lg x 15/16" h x 3/32" wd o/a, 0.025" thk material; approx 5/8" max jaw opening; "U" shaped w/formed ear on bottom and cutout on each side	Holds E-1105 to A-1104	N17-T-350013-725	CTT	151410	151410	0-1105, 0-1108	2	-	-	-	-
0-1106	SPACER: brass tubing; approx 1/4" OD x 1/8" ID x 11/16" lg o/a; mts by ID	Spaces S-1104 and A-1104	N17-T-350013-724	CTT	151407	151407	0-1106	2	-	-	-	-
0-1107	SPRING: helical extension type; 0.014" diam music wire; approx 11/16" lg x 5/32" OD x 1/8" ID o/a; approx 28 turns; hook term ea end indexed 90°; mts by terms	Applies tension to E-1105	N17-T-350006-358	CTT	3870	3870	0-1107	1	-	-	-	-
0-1108	Same as 0-1105	Holds 0-1109 and E-1107 to A-1104										

# 0-755 to 0-771 used on CY-870/UG and CY-871/UG

PARTS LISTS

TT-47/UG, TT-48/UG, TT-69/UG, TT-70/UG

NAVSHIPS 91393

Section 8  
0-769-O-1108

8-121

8-122

CHANGE 1

TABLE 8-4. COMBINED PARTS AND SPARE PARTS LIST

SYMBOL DESIG.	NAME OF PART AND DESCRIPTION	FUNCTION	JAN OR NAVY TYPE DESIGNATION	STANDARD NAVY STOCK NUMBER	MANUFACTURERS		TELETYPE PART NO.	ALL SYMBOL DESIGNATIONS INVOLVED	TOTAL NO. PER EQUIP.	SPARE PARTS			
					CODE	DESIG.				EQUIP.		STOCK	
										BOX	QUAN.	BOX	QUAN.
0-1109	LEVER: steel, nickel plated; irregular shaped w/three wings, 2 wings w/cutouts, third wing irregular "L" shaped w/formed ear on end; approx 1 11/16" lg x 1" h x 1/4" wide o/a, 0.050" thk material; mts by two wings w/cutouts; body hole between two wings	Guide for E-1105		N17-T-350013-764	CTT	151408	151408	0-1109	1	-	-	-	-
0-1110	Same as 0-148	Applies tension to 0-1109											
0-1111	Same as 0-117	Applies tension to E-1107											
0-1112	CORE: iron, nickel plated; c/o head, body, threaded shank w/slotted end; approx 2 1/16" lg x 1/2" diam o/a; mts by 5/16" - 32 threaded shank	Holds E-1108 to A-1105 and contact for E-1107		N17-T-350013-721	CTT	151402	151402	0-1112	2	-	-	-	-
0-1114	SPACER: steel, oxidized copper finish; approx 1/4" OD x 5/32" ID x 9/32" lg o/a; mts by ID	Spaces TB-1101 and TB-1103		N17-T-350003-590	CTT	97908	97908	0-1114	1	-	-	-	-
0-1301	SPRING: helical extension type; 0.010" diam music wire; approx 11/32" lg x 1/8" OD x 3/32" ID o/a; approx 13 turns; parallel hook term ea end; mts by terms	Applies tension to 0-1307		N17-T-350013-616	CTT	45027	45027	0-1301, 0-1618, 0-1620, 0-1645	4	1	1	-	-
0-1302	Same as 0-288	Lubricates 0-1303 and H-1302											
0-1303	BAIL: steel, nickel plated; "V" shaped w/irregular formed ears, three spring notches, "U" formed at point of "V"; approx 1 11/16" lg x 1 9/16" wd x 11/16" h o/a, 0.050" thk material; mts by 2 holes in line	Operates 0-1307		N17-T-350014-833	CTT	150054	150054	0-1303	1	-	-	-	-
0-1304	SPRING: helical extension type; 0.024" diam music wire; approx 1 1/4" lg x 3/16" OD x 5/32" ID o/a; approx 35 turns; parallel hook term ea end; mts by terms	Applies tension to 0-1303		N17-T-350008-717	CTT	80848	80848	0-1304	1	1	1	-	-
0-1305	HEAD, hammer: steel, nickel plated; irregular shape, shank in front, body partly tapered toward shank, curved, flat ear at back; approx 1/2" lg x 7/32" diam o/a; mts by CSK hole in ear	Operates 0-1854 and 0-1858 to 0-1908		N17-T-350014-867	CTT	150061	150061	0-1305	1	1	2	-	-
0-1306	SPRING: helical extension type; 0.016" diam music wire; approx 3/8" lg x 1/8" OD x 3/32" ID o/a; approx 10 turns; parallel hook terminals; mts by terminals.	Applies tension to 0-1305		N17-T-350006-313	CTT	112633	112633	0-1306	1	1	1	-	-
0-1307	BAIL: steel, nickel plated; irregular shaped and formed, "U" shaped one end, hammer welded to other end, 2 spring notched formed ears; approx 2 7/16" lg x 3/4" h x 7/8" wd o/a, 0.042 thk material; mts by 2 holes in line in sides of "U"	Operates 0-1305		N17-T-350014-527	CTT	150059	150059	0-1307	1	-	-	-	-

8 Section  
O-1109—O-1307

TT-47/UG, TT-48/UG, TT-69/UG, TT-70/UG

NAVSHIPS 91393

PARTS LISTS

CHANGE 1

8-123

0-1308	BRACKET: irregular shape w/three formed ears; steel, nickel plated; approx 2" lg x 1 3/8" h x 7/16" wd o/a, 0.042" thk material; mts by body hole at ea end of body; csk hole in one ear	Stop and guide for 0-1307 and 0-1303	N17-T-350014-617	CTT	150065	150065	0-1308	1	-	-	-	-
0-1309	Same as 0-125	Applies tension to 0-1310										
0-1310	LATCH: steel, nickel plated; irregular shape w/3 arms, longest arm has small cutout w/rise on side; approx 1 7/32" lg x 23/32" h x 0.065" thk o/a; mts by hole in ctr of body; csk hole in rounded arm	Operates 0-1303	N17-T-350014-613	JTT	150038	150038	0-1310	1	1	1	-	-
0-1311	WASHER, felt: hard, white felt; round, approx 1/2" OD x 1/4" ID x 1/16" thk o/a	Lubricates 0-1310	N17-T-350014-332	CTT	150923	150923	0-1311, 0-1542	2	-	-	-	-
0-1312	BRACKET: irregular shape w/rounded ends; steel, nickel plated; approx 2 5/16" lg x 1/2" h x 11/16" wd o/a, 0.035" thk material; mts by hole at ea end; formed arm one end, formed wing w/2 holes other end, "U" shaped at end of wing	Advances A-1302	N17-T-350013-963	CTT	150238	150238	0-1312	1	-	-	-	-
0-1313	PLATE: steel, nickel plated; rectangular w/rounded corners; approx 5/8" lg x 3/8" wd x 1/16" thk o/a; mts by 2 tapped holes	Clamps W-1303 to 0-1312	N17-T-350013-913	CTT	150230	150230	0-1313	1	-	-	-	-
0-1314	BUSHING: steel, piston finish; male; approx 1/16" thk x 3/16" OD x 1/8" ID o/a	Axle for 0-1315 and spaces 0-1317 and H-1312 from 0-1315	N17-T-350013-745	CTT	151611	151611	0-1314, 0-2090	3	-	-	-	-
0-1315	ROLLER, bearing: steel; approx 3/8" OD x 3/16" ID x 1/16" thk o/a; mts by ID	Roller for printing carriage mechanism	N43-W-7522-313	CTT	150030	150030	0-1315, 0-1318	4	1	2	-	-
0-1316	Same as 0-255	Lubricates 0-1314, 0-1315 and 0-1317										
0-1317	SPACER: steel, nickel plated; approx 1/4" thk x 15/32" OD x 1/8" ID o/a; mts by ID; rounded from approx 9/32" diam shoulder to 0.031" thk head	Guides 0-1315 along A-1324	N17-T-350013-746	CTT	151612	151612	0-1317, 0-1320	3	-	-	-	-
0-1318	Same as 0-1315	Roller for printing carriage mechanism										
0-1319	Same as 0-255	Lubricates 0-1318										
0-1320	Same as 0-1317	Guides 0-1318 along A-1324										
0-1321	BRACKET: irregular shape; steel, nickel plated; approx 15/16" lg x 1 9/16" wd x 3/8" h o/a, 0.042" thk material; mts by elongated slot in ctr of body; 2 formed arms and 1 straight arm w/ck hole	Adjusting anchor for 0-1304	N17-T-350014-130	CTT	150053	150053	0-1321	1	-	-	-	-
0-1322	SLIDE: steel, nickel plated; cylindrical body w/rectangular head; approx 1/2" lg x 3/8" wd x 3/16" h o/a; mts by body diam; neck groove at 1 end of body, slot in head	Pivot for 0-1324	N17-T-350013-815	CTT	150039	150039	0-1322	1	1	1	-	-
0-1323	Same as 0-248	Lubricates 0-1322 and 0-1324										

PARTS LISTS

TT-47/UG, TT-48/UG, TT-69/UG, TT-70/UG

NAVSHIPS 91393

O-1308-O-1323

Section 8

TABLE 8-4. COMBINED PARTS AND SPARE PARTS LIST

SYMBOL DESIG.	NAME OF PART AND DESCRIPTION	FUNCTION	JAN OR NAVY TYPE DESIGNATION	STANDARD NAVY STOCK NUMBER	MANUFAC- TURERS		TELETYPE PART NO.	ALL SYMBOL DESIGNATIONS INVOLVED	SPARE PARTS				
					CODE	DESIG.			TOTAL NO. PER EQUIP.	EQUIP.		STOCK	
										BOX	QUAN.	BOX	QUAN.
0-1324	ARM: steel, nickel plated; irregular shaped w/two arms, one arm curved and formed at end, other arm has two rounded ears on one side w/body hole near ea ear, hub butt welded to ea end; approx 2 13/16" lg x 2 13/16" h x 7/16" wd o/a, 0.050" thk material; mts by ID of hubs	Operates 0-1310 and 0-1303		N17-T-350014-750	CTT	150068	150068	0-1324	1	-	-	-	-
0-1325	BUSHING: steel; male; approx 1/4" lg x 7/32" OD x 1/8" ID o/a	Bearing for 0-1324		N17-T-350013-814	CTT	150037	150037	0-1325	1	-	-	-	-
0-1326	WASHER, felt: hard, white felt; round, 1/4" ID x 1/2" OD x 3/32" thk	Lubricates 0-1324 and 0-1325		N17-T-350013-629	CTT	90361	90361	0-1326, 0-1741, 0-1997, 0-2006, 0-2012	9	1	3	-	-
0-1327	ARM: steel, nickel plated; irregularly shaped, one end rounded, two tapped body holes, two curved cutouts one side; approx 1 11/32" lg x 5/16" wd x 0.065" thk o/a; mts by tapped body holes	Operates 0-1310		N17-T-350014-853	CTT	151709	151709	0-1327	1	-	-	-	-
0-1328	PLATE, retainer: steel, nickel plated; approx 1" lg x 5/8" wd x 0.035" thk o/a; mts by body slot and hole, angular cutaway one side	Holds 0-1471 through 0-1476 in position		N17-T-350014-161	CTT	150301	150301	0-1328	1	-	-	-	-
0-1329	POST, code bar: steel; approx 1 3/16" lg x 5/32" diam o/a; mts by tapped hole near ea end; one end slotted	Holds 0-1332 through 0-1339 and 0-1342 in position in A-1303		N17-T-350014-233	CTT	150289	150289	0-1329, 0-1345	2	1	2	-	-
0-1330	BAR, tie: steel, nickel plated; approx 9 15/16" lg x 1/2" h x 3/16" wd o/a, 0.050 thk material; mts by elongated hole one end and body hole other end; formed lip one side w/cut out on ea end in body, 2 elongated holes and 2 body holes	Mounts 0-1331		N17-T-350014-235	CTT	150285	150285	0-1330	1	-	-	-	-
0-1331	BRACKET: irregular shaped; steel, nickel plated; approx 1 3/32" lg x 1 3/32" h x 5/16" wd o/a, 0.050" thk material; mts by 2 tapped holes in one formed side; 9 slots in other formed side	Guides 0-132 through 0-1339 and 0-1342		N17-T-350014-158	CTT	150304	150304	0-1331	1	-	-	-	-
0-1332	CODE BAR: steel, nickel plated; irregular shape, 43 sq. edged teeth on one side, arm at ea end, one w/4 pointed teeth and small cut out, elongated cut out near other end; approx 11 13/16" lg x 7/8" h x 9/16" wd o/a, 0.042" thk material; mts by small elongated slot at ea end; two elongated slots in body, one with small cutout at end near pin riveted to body	Vertically positions type box mechanism through 0-1914, space suppression code bar		N17-T-350014-620	CTT	150279	150279	0-1332	1	-	-	-	-

0-1333	CODE BAR: steel, nickel plated; irregular shape, 43 sq edged teeth one side, two cutouts, slot and two ears other side, four pointed teeth and cutout one end, other ends straight, elongated slot and rectangular shaped hole in body; approx 11" lg x 15/16" h x 0.042" thk o/a; mts by elongated slot near ea end	Determines the selection of one row from four vertical rows, in type box mechanism, selected by 0-1337, #4 code bar	N17-T-350014-529	CTT	150281	150281	0-1333, 0-1335	2	-	-	-	-
0-1334	CODE BAR: steel, nickel plated; irregular shape, 43 sq edged teeth on one side, arm at ea end, one w/four pointed teeth and two cutouts, elongated cutout near other end; approx 11 5/8" lg x 7/8" h x 0.042" thk o/a; mts by small elongated slot at ea end; two large elongated slots	Vertically positions type box mechanism through 0-1914, #1 code bar	N17-T-350014-619	CTT	150278	150278	0-1334, 0-1336, 0-1338	3	-	-	-	-
0-1335	Same as 0-1333	Determines the selection of one row from four vertical rows, in type box mechanism, selected by 0-1337, #5 code bar										
0-1336	Same as 0-1334	Vertically positions type box mechanism through 0-1914, #2 code bar										
0-1337	CODE BAR: steel, nickel plated; irregular shape, 43 sq edged teeth one side, 2 rounded ears, 1 irregular shaped pointed ear and elongated cutout on other side, arm w/2 cutouts and 4 pointed teeth on one end; approx 11" lg x 1 3/16" h x 0.042" thk o/a; mounts by small elongated slot at ea end; 2 elongated body slots	Determines whether selection is made from left four vertical rows or right four vertical rows in letters or figures end of type box mechanism, #3 code bar	N17-T-350014-621	CTT	150282	150282	0-1337	1	-	-	-	-
0-1338	Same as 0-1334	Vertically positions type box mechanism through 0-1914, common code bar										
0-1339	CODE BAR: steel, nickel plated; irregular shape, 2 teeth one side, 2 rounded ears, 1 formed ear w/elongated cutout on end, elongated cutout near formed ear; approx 9 13/16" lg x 15/16" h x 5/16" wd o/a, 0.042" thk material; mts by small elongated slot ea end; two elongated body slots	Operates automatic carriage return and line feed	N17-T-350014-256	CTT	150284	150284	0-1339	1	-	-	-	-
0-1341	BRACKET: irregular "U" shape, stud riveted to one side; steel, nickel plated; approx 1 3/16" lg x 1 5/16" wd x 13/32" h o/a, 0.050" thk material; mts by two #4-40 holes in one side	Operates 0-1342	N17-T-350014-257	CTT	150288	150288	0-1341	1	-	-	-	-
0-1342	CODE BAR: steel, nickel plated; irregular shape, 43 sq edged teeth one side, two rounded ears, one formed ear w/cutout at end and 1 elongated cutout other side, arm w/2 cutouts and 4 pointed teeth one end; approx 11" lg x 15/16" h x 5/16" wd o/a, 0.042" thk material; mts by small elongated slot ea end; elongated slot near ctr, elongated hole and body hole near straight end	Operates shift and unshift mechanisms	N17-T-350014-751	CTT	150283	150283	0-1342	1	-	-	-	-

CHANGE 1

8-125

TABLE 8-4. COMBINED PARTS AND SPARE PARTS LIST

PARTS										SPARE PARTS			
SYMBOL DESIG.	NAME OF PART AND DESCRIPTION	FUNCTION	JAN OR NAVY TYPE DESIGNATION	STANDARD NAVY STOCK NUMBER	MANUFAC- TURERS		TELETYPE PART NO.	ALL SYMBOL DESIGNATIONS INVOLVED	TOTAL NO. PER EQUIP.	EQUIP.		STOCK	
					CODE	DESIG.				BOX	QUAN.	BOX	QUAN.
0-1343	PLATE, retainer: steel, nickel plated; approx 1 3/16" lg x 7/16" wd x 0.025" thk o/a; mts by body hole at ea end	Holds 0-1348 in A-1305		N17-T-350014-252	CTT	150293	150293	0-1343	2	-	-	-	-
0-1344	PLATE, reinforcing: aluminum, plain anodized; 8 slots one side, one corner cutoff; approx 1/4" lg x 1/2" h x 1/8" wd o/a; mts by hole near ea end	Guides 0-1332 through 0-1339 and 0-1342		N17-T-350014-231	CTT	150292	150292	0-1344	1	-	-	-	-
0-1345	Same as 0-1329	Holds 0-1332 through 0-1339 and 0-1342 in position in A-1304											
0-1346	SHIM: steel; approx 7/8" lg x 9/32" h x 0.006" thk o/a; mts by slot in center; rounded ear on ctr of one side	Spaces A-1305 and A-1304		N17-T-350014-160	CTT	150302	150302	0-1346	4	1	4	-	-
0-1347	WASHER, felt: hard, white felt; round, approx 13/16" OD x 7/32" ID x 1/32" thk o/a	Lubricates 0-1360		N17-T-350013-995	CTT	150320	150320	0-1347, 0-1393	2	1	2	-	-
0-1348	SPRING: helical compression type; 0.012" diam music wire; approx 9/32" lg x 5/32" OD o/a; 7 turns; closed ends	Applies pressure to 0-1349		N17-T-350014-216	CTT	150535	150535	0-1348	16	1	3	-	-
0-1349	BALL, bearing: carbon steel; spherical; approx 5/32" diam o/a	Bearing for and positions 0-1332 through 0-1339 and 0-1342		N17-T-350014-214	CTT	150537	150537	0-1349, 0-2134	17	1	6	-	-
0-1350	SHAFT: steel; two grooves near ea end; approx 1 5/8" lg x 5/32" diam o/a; mts by grooved ends	Pivot for 0-1353 and 0-1354		N17-T-350013-986	CTT	150331	150331	0-1350, 0-1381	2	-	-	-	-
0-1351	BAIL: steel, nickel plated; irregular "U" shape w/2 ears on ea side; approx 1 1/2" lg x 1 1/16" h x 1/2" wd o/a, 0.042" thk material; mts by 2 holes in line in both opposite ears; rectangular hole in base of "U"	Mounts 0-1350		N17-T-350013-985	CTT	150332	150332	0-1351, 0-1383	2	-	-	-	-
0-1352	BUSHING: steel, nickel plated; male; approx 5/16" OD x 1/8" ID x 3/32" lg o/a; 5/32" diam body	Bushing and pivot for 0-1356		N17-T-350014-530	CTT	150336	150336	0-1352, 0-1394, 0-1579	3	-	-	-	-
0-1353	LEVER: steel, nickel plated; irregular shape, 2 arms formed at end on one end, 2 rounded formed ears on other end, spring notched ear one side; approx 1 7/8" lg x 1 1/4" h x 3/8" wd o/a, 0.035" thk material; mts by 2 holes in line in rounded ears; LH mtg, rectangular shaped slot in ctr of body	Steps 0-1364		N17-T-350013-998	CTT	150315	150315	0-1353	1	1	1	-	-

8-126

CHANGE 1

CHANGE 1

8-127

0-1354	LEVER: steel, nickel plated; irregular shape, "U" formed one end, other end formed, two ears on one side, one spring notched; approx 1 3/16" lg x 13/16" h x 5/16" wd o/a; 0.035" thk material; mts by 2 holes in line inside of "U", LH mtg	Stops and releases 0-1364 and operates 0-1353	N17-T-350013-987	CTT	150330	150330	0-1354	1	1	1	-	-
0-1355	SPRING: helical extension type; 0.010" diam music wire; approx 11/32" lg x 1/8" OD o/a; approx 27 turns; parallel hook terminals, mts by terms	Applies tension to 0-1353	N17-T-350006-578	CTT	84575	84575	0-1355, 0-1357, 0-1362, 0-1390, 0-1397, 0-1398	6	-	-	-	-
0-1356	LEVER: steel, nickel plated; irregular "Y" shape, one body and two formed ears one end, other end curved, notch near end of base; approx 2 7/8" lg x 2" h x 5/8" wd o/a, 0.035" thk material; mts by body hole in base; LH mtg	Guide for 0-1358 and operates 0-1402	N17-T-350014-154	CTT	150310	150310	0-1356	1	-	-	-	-
0-1357	Same as 0-1355	Applies tension to 0-1356										
0-1358	SPOOL, printing ribbon: 11 yds lg x 0.005" thk; black record ribbon, extra heavy inked, Underwood spool, 17 thds per 1/8", base ink blue	Ink supply and operates 0-1356	N17-T-350001-535	COOD CO.	MFG. #301	7835	0-1358	1	-	-	-	-
0-1360	SHAFT: steel, nickel plated; irregular shape, c/o head w/slot near end and cutouts on two sides, shield with riveted pin, body w/toggle inserts in slot at end and mtd by pin; approx 1 9/16" lg x 3/4" diam o/a; mts by head	Mounts and operates 0-1359	N17-T-350013-994	CTT	150321	150321	0-1360, 0-1392	2	-	-	-	-
0-1361	ROLLER: aluminum, plain anodized; approx 5/8" lg x 3/8" OD x 3/16" ID o/a; mts by ID; flanged ends	Roller and guide for 0-1358	N17-T-350013-989	CTT	150327	150327	0-1361, 0-1396	2	-	-	-	-
0-1362	Same as 0-1355	Applies tension to 0-1354										
0-1363	WICK: hard white felt; approx 1" lg x 1/8" diam	Lubricates 0-1304	N17-T-350013-907	CTT	108199	108199	0-1363, 0-1654, 0-1721	3	1	1	-	-
0-1364	RATCHET, ribbon: steel, nickel plated; approx 1 1/2" OD x 7/32" ID x 3/16" h, o/a; 0.035" thk material; mts by ID; 70 teeth around circum, irregular shaped cutout on face w/formed ear, LH mtg	Operates 0-1366	N17-T-350014-156	CTT	150308	150308	0-1364	1	1	1	-	-
0-1365	SPRING: loop type; 0.040" diam music wire; approx 3/4" lg x 9/16" wd x 1/2" ID o/a, 0.040" thk; mts by parallel prong ends	Positions 0-1364 and 0-1366	N17-T-350013-992	CTT	150324	150324	0-1365, 0-1401	2	-	-	-	-
0-1366	RETAINER, spring: steel, nickel plated; approx 3/4" diam, 1/8" wd o/a, 0.035" thk material; mts by elongated slot in ctr; formed ear in cutout on circum	Operates 0-1360	N17-T-350013-991	CTT	150325	150325	0-1366, 0-1403	2	-	-	-	-
0-1367	SPRING: helical compression type; 0.024" diam music wire; approx 11/32" lg x 5/16" OD x 1/4" ID o/a; approx 4 1/2 turns; closed ends; mts by ID	Applies pressure to 0-1364 through 0-1366 and H-1358	N17-T-350013-932	CTT	150663	150663	0-1367, 0-1404	2	1	2	-	-

PARTS LISTS

TT-47/UG, TT-48/UG, TT-69/UG, TT-70/UG

NAVSHIPS 91393

0-1354-0-1367

Section 8



TABLE 8-4. COMBINED PARTS AND SPARE PARTS LIST

SYMBOL DESIG.	NAME OF PART AND DESCRIPTION	FUNCTION	JAN OR NAVY TYPE DESIGNATION	STANDARD NAVY STOCK NUMBER	MANUFAC- TURERS		TELETYPE PART NO.	ALL SYMBOL DESIGNATIONS INVOLVED	TOTAL NO. PER EQUIP.	SPARE PARTS			
					CODE	DESIG.				EQUIP.		STOCK	
										BOX	QUAN.	BOX	QUAN.
0-1368	BUSHING: steel, nickel plated; male; approx 3/8" OD x 1/8" ID x 1/8" lg o/a, body 3/16" diam	Bushing and pivot for 0-1369		N17-T-350014-340	CTT	150932	150932	0-1368, 0-1389	2	-	-	-	-
0-1369	LEVER: steel, nickel plated; irregular shape, one end rounded w/elongated cutout on side, other end formed; approx 15/16" lg x 1/2" h x 5/32" wd o/a, 0.035" thk material; mts by hole in rounded end; LH mtg	Operates 0-1354		N17-T-350014-627	CTT	150343	150343	0-1369	1	-	-	-	-
0-1370	WASHER, felt: hard, white felt; round, 5/32" ID x 3/8" OD x 1/16" thk	Lubricates 0-1303 and 0-1307		N17-T-350013-795	CTT	109762	109762	0-1370	1	1	1	-	-
0-1371	SPACER: steel, nickel plated; approx 9/32" lg x 9/32" OD x 1/8" ID o/a; mts by ID	Spaces A-1311 and left side frame		N17-T-350014-624	CTT	150338	150338	0-1371	3	-	-	-	-
0-1372	SHIM: steel; approx 5/16" OD x 5/32" ID x 0.008" thk o/a; mts by ID	Adjusting shim for H-1302		N17-T-350014-513	CTT	90599	90599	0-1372	4	-	-	-	-
0-1373	GEAR: spur; steel; straight teeth; 12 teeth; 48 pitch, 0.25 PD approx 5/16" OD x 1/8" ID x 3/32" thk o/a; straight face; mts by ID	Operates 0-1402 or 0-1374		N17-T-350014-623	CTT	150335	150335	0-1373, 0-1376	2	-	-	-	-
0-1374	SHAFT: steel; body w/slot near one end and threaded shank on both ends; approx 11" lg x 5/32" diam o/a; mts by threaded shank ea end	Operates 0-1375 and either 0-1373 or 0-1376		N17-T-350014-622	CTT	150334	150334	0-1374	1	-	-	-	-
0-1375	CAM: steel, nickel plated; hub welded to ID of cam, three rises on one side of cam; approx 5/8" OD x 1/8" ID x 11/16" lg o/a; mts by ID two tapped holes in hub, fall diam approx 3/8"	Operates 0-1378		N17-T-350014-341	CTT	150934	150934	0-1375	1	-	-	-	-
0-1376	Same as 0-1373	Operates 0-1387 or 0-1374											
0-1377	BUSHING: steel, nickel plated; male, approx 3/8" OD x 1/8" ID x 3/32" lg o/a, c/o head, slot and 7/32" diam body	Bushing and pivot for 0-1377		N17-T-350014-535	CTT	150436	150436	0-1377, 0-1587, 0-2062	3	-	-	-	-
0-1378	LEVER: steel, nickel plated; rounded ends, bend near ctr; pin riveted to small end; approx 1 9/16" lg x 9/16" h x 3/16" wd o/a, 0.050" thk material; mts by hole in large end; hole csk on both sides at bend	Locks 0-1375 in two positions		N17-T-350014-343	CTT	150937	150937	0-1378	1	-	-	-	-
0-1379	SPACER: steel, nickel plated; approx 5/16" OD x 1/8" ID x 3/32" thk o/a; mts by ID	Spaces 0-1378 from right side frame		N17-T-350006-711	CTT	8449	8449	0-1379, 0-1742	2	1	1	-	-

8-128

CHANGE 1

CHANGE 1

0-1380	SPRING: helical extension type; 0.016" diam music wire; approx 15/16" lg x 5/32" OD x 1/8" ID o/a; approx 39 turns; hook terms ea end indexed 90°; mts by terms	Applies tension to 0-1378	N17-T-350006-446	CTT	74701	74701	0-1380, 0-1698, 0-1707, 0-1714, 0-1718, 0-1726, 0-1731, 0-1736, 0-1739	9	1	3	-	-
0-1381	Same as 0-1350	Pivot for 0-1384 and 0-1385										
0-1383	Same as 0-1351	Mounts 0-1381										
0-1384	LEVER: steel nickel plated; irregular shape, "U" formed one end, other end formed, two ears on one side, one spring notched; approx 1 3/16" lg x 13/16" h x 5/16" wd o/a, 0.035" thk material; mts by two holes in line in sides of "U"; RH mtg	Stops and releases 0-1364 and operates 0-1385	N17-T-350013-988	CTT	150329	150329	0-1384	1	1	1	-	-
0-1385	LEVER: steel, nickel plated; irregular shape, two arms formed at end on one end, two rounded formed ears on other end, spring notched ear one side; approx 1 7/8" lg x 1 1/4" h x 3/8" wd o/a, 0.035" thk material; mts by two holes in line in rounded ears; RH mtg, rectangular shaped slot in ctr of body	Steps 0-1400	N17-T-350013-999	CTT	150314	150314	0-1385	1	1	1	-	-
0-1386	SPACER: aluminum, plain anodized; approx 1/2" OD x 1/8" ID x 1/8" thk o/a; mts by ID	Spaces 0-1387 and right side frame	N17-T-350014-292	CTT	150821	150821	0-1386	1	-	-	-	-
0-1387	LEVER: steel, nickel plated; irregular shape, one end rounded, other end curves into arm with 4 teeth on inside of arm, central extending arm has elongated hole in body end; approx 1 1/4" lg x 1 11/16" h x 1/16" thk o/a, 0.050" thk material; mts by hole in rounded end	Operates 0-1388 and 0-1376	N17-T-350014-386	CTT	150307	150307	0-1387	1	-	-	-	-
0-1388	LEVER: steel, nickel plated; irregular shape, one end rounded w/elongated cutout on side, other end formed; approx 15/16" lg x 1/2" h x 5/32" wd o/a, 0.035" thk material; mts by hole in rounded end; RH mtg	Operates 0-1384	N17-T-350014-628	CTT	150344	150344	0-1388	1	-	-	-	-
0-1389	Same as 0-1368	Bushing and pivot for 0-1388										
0-1390	Same as 0-1355	Applies tension to 0-1395										
0-1391	SPOOL, printing ribbon: sheet metal black high gloss finished; 2" OD x 5/8" wd x 3/16" ID o/a; mtg hole 3/16" diam; 5/8" diam ribbon mtg drum	Spool for 0-1358	N17-T-350007-565	CTT	71681	71681	0-1391	1	-	-	-	-
0-1392	Same as 0-1360	Mounts and operates 0-1391										
0-1393	Same as 0-1347	Lubricates 0-1392										
0-1394	Same as 0-1352	Bushing and pivot for 0-1395										
0-1395	LEVER: steel, nickel plated; irregular "Y" shape, two formed and one body ear one end, notch in end of base; approx 2 7/8" lg x 2" h x 5/8" wd o/a, 0.035" thk material; mts by hole in base; RH mtg	Guide for 0-1358 and operates 0-1387	N17-T-350014-153	CTT	150311	150311	0-1395	1	-	-	-	-

8-129

PARTS LISTS

TT-47/UG, TT-48/UG, TT-69/UG, TT-70/UG

NAVSHIPS 91393

Section 8  
0-1380-0-1395

TABLE 8-4. COMBINED PARTS AND SPARE PARTS LIST

PARTS								SPARE PARTS					
SYMBOL DESIG.	NAME OF PART AND DESCRIPTION	FUNCTION	JAN OR NAVY TYPE DESIGNATION	STANDARD NAVY STOCK NUMBER	MANUFACTURERS		TELETYPE PART NO.	ALL SYMBOL DESIGNATIONS INVOLVED	TOTAL NO. PER EQUIP.	EQUIP.		STOCK	
					CODE	DESIG.				XOR	QUAN.	XOR	QUAN.
0-1396	Same as 0-1361	Roller and guide for 0-1358											
0-1397	Same as 0-1355	Applies tension to 0-1385											
0-1398	Same as 0-1355	Applies tension to 0-1384											
0-1399	PLATE: steel, nickel plated; irregularly shaped w/2 elongated cutouts one side, straight cutout other side, one body hole and one mounting hole; approx 27/32" lg x 3/4" h x 0.042" thk o/a; mts by tapped hole	Retaining plate for 0-1428, 0-1429 and 0-1430		N17-T-350014-599	CTT	151706	151706	0-1399	1	-	-	-	-
0-1400	RATCHET, ribbon: steel, nickel plated; approx 1 1/2" OD x 7/32" ID x 3/16" thk o/a, 0.035" thk material; mts by ID; 70 teeth around circum, irregular shaped cutout on face w/formed ear, RH mtg	Operates 0-1403		N17-T-350014-155	CTT	150309	150309	0-1400	1	1	1	-	-
0-1401	Same as 0-1365	Positions 0-1400 and 0-1403											
0-1402	LEVER: steel, nickel plated; irregular shape, one end rounded, curved in approx ctr, four teeth on one side of curve; approx 1 1/4" lg x 1 1/8" h x 3/32" thk o/a, 0.042" thk material; mts by hole in rounded end; slot at curve w/pin riveted below slot	Operates 0-1369 and 0-1373		N17-T-350014-157	CTT	150306	150306	0-1402	1	-	-	-	-
0-1403	Same as 0-1366	Operates 0-1392											
0-1404	Same as 0-1367	Applies pressure to 0-1393, A-1307, 0-1400, 0-1401, 0-1403, and H-1393											
0-1405	Same as 0-214	Applies tension to function bars											
0-1406	LEVER FUNCTION: steel, nickel plated; irregular shape w/five ears formed to one side, one ear formed to other side, arm on wide end notched ear in ctr; approx 2 7/8" lg x 1 1/4" h x 5/32" wd o/a, 0.042" thk material; mts by cutout in narrow end; "SP" stamped in wd end	Operates 0-1433		N17-T-350013-928	CTT	150605	150605	0-1406	1	-	-	-	-
0-1407	LEVER, FUNCTION: steel, nickel plated; irregular shape w/five formed ears and arm on wd end and notched ear in ctr; approx 2 7/8" lg x 1 1/4" h x 3/32" wd o/a, 0.042" thk material; mts by cutout in narrow end; "LTR" stamped in wd end	Operates 0-1445		N17-T-350014-193	CTT	150600	150600	0-1407	1	-	-	-	-

8-130

CHANGE 1

CHANGE 1

8-131

0-1408	LEVER, FUNCTION: steel, nickel plated; irregular shape w/four ears formed to one side, one ear formed to other side, arm on wd end, notched ear in ctr; approx 2 7/8" lg x 1 1/4" h x 5/32" wd o/a, 0.042" thk material; mts by cutout in narrow end; "FIG" stamped in wd end	Operates 0-1446	N17-T-350014-192	CTT	150601	150601	0-1408	1	-	-	-	-
0-1409	LEVER, FUNCTION: steel, nickel plated; irregular shape w/one formed ear and arm on wd end, notched ear in ctr; approx 2 7/8" lg x 1 1/4" h x 3/32" wd o/a, 0.042" thk material; mts by cutout in narrow end; "CR LF" stamped in wd end	Operates 0-1447	N17-T-350013-886	CTT	150606	150606	0-1409, 0-1414	2	-	-	-	-
0-1410	LEVER, FUNCTION: steel, nickel plated; irregular shape w/four ears formed to one side, one ear formed to other side, arm on wd end, notched ear in ctr; approx 2 7/8" lg x 1 1/4" h x 5/32" wd o/a, 0.042" thk material; mts by cutout in narrow end; "CR" stamped in wd end	Operates 0-1448	N17-T-350013-883	CTT	150602	150602	0-1410	1	-	-	-	-
0-1411	LEVER, FUNCTION: steel, nickel plated; irregular shape w/three ears formed to one side, three ears formed to other side, arm on narrow end, notched ear on ctr; approx 2 7/8" lg x 1 1/4" h x 5/32" wd o/a, 0.042" thk material; mts by cutout in narrow end; "UC.S" stamped in wd end	Operates 0-1449	N17-T-350013-887	CTT	150607	150607	0-1411	1	-	-	-	-
0-1412	LEVER, FUNCTION: steel, nickel plated; irregular shape w/five formed ears and arm on wd end, notched ear in ctr; approx 2 7/8" lg x 1 1/4" h x 3/32" wd o/a, 0.042" thk material; mts by cutout in narrow end; "BL" stamped in wide end	Operates 0-1454	N17-T-350013-885	CTT	150604	150604	0-1412, 0-1413	2	-	-	-	-
0-1413	Same as 0-1412	Operates 0-1450										
0-1414	Same as 0-1409	Operates 0-1451										
0-1415	LEVER, FUNCTION: steel, nickel plated; irregular shape w/four ears formed to one side, one ear formed to other side, arm on wd end, notched ear in ctr; approx 2 7/8" lg x 1 1/4" h x 5/32" wd o/a, 0.042" thk material; mts by cutout in narrow end; "LF" stamped in wd end	Operates 0-1452	N17-T-350013-884	CTT	150603	150603	0-1415, 0-1416	2	-	-	-	-
0-1416	Same as 0-1415	Operates 0-1453										
0-1417	PLATE, GUIDE: steel, nickel plated, approx 9 1/4" lg x 1 1/4" wd x 0.042" thk o/a; mts by five elongated slots along one side; 42 large elongated slots, 42 small elongated slots and 42 holes in a row, hole at one end, elongated slot at other end	Guide for 0-1406 through 0-1416 and anchor for 0-1405 and 0-1432	N17-T-350013-881	CTT	150568	150568	0-1417	1	-	-	-	-
0-1418	GUIDE: aluminum, plain anodize finish; two slots along lg, six slots at ea end; approx 9 1/4" lg x 2" h x 3/16" wd o/a; mts by 5 tapped holes; seven ctb holes, eight tapped holes and eight holes through wd, guide stud pressed in wd on same side as mtg hole on ea end	Guide for function bar	N17-T-350013-581	CTT	150567	150567	0-1418	1	-	-	-	-

PARTS LISTS

TT-47/UG, TT-48/UG, TT-69/UG, TT-70/UG

NAVSHIPS 91393

Section 8  
O-1408—O-1418

TABLE 8-4. COMBINED PARTS AND SPARE PARTS LIST

SYMBOL DESIG.	NAME OF PART AND DESCRIPTION	FUNCTION	JAN OR NAVY TYPE DESIGNATION	PARTS				SPARE PARTS					
				STANDARD NAVY STOCK NUMBER	MANUFAC- TURERS		TELETYPE PART NO.	ALL SYMBOL DESIGNATIONS INVOLVED	TOTAL NO. PER EQUIP.	EQUIP.		STOCK	
					CODE	DESIG.				QTY	QTY	QTY	QTY
0-1419	BAR, GUIDE: aluminum, plain anodize finish; irregular shaped cutouts along length of bar, 29 slots in sides; approx 9 1/4" lg x 1 1/16" h x 1 1/16" wd o/a; mts by seven tapped holes along one side; three holes on same side as mtg holes, tapped hole in each end, two shafts staked in deepest squared cutouts	Guide for function pawls, bars and levers		N17-T-350013-580	CTT	150566	150566	0-1419	1	-	-	-	-
0-1420	BLOCK, GUIDE: steel, nickel plated; approx 5/16" lg x 3/16" h x 5/32" wd o/a; mts by tapped hole; hole on opposite side of mtg hole	Guide and support for 0-1439		N17-T-350013-595	CTT	150689	150689	0-1420	3	-	-	-	-
0-1421	SLIDE: steel, nickel plated; lg narrow body, elongated cutout one side; approx 2 1/2" lg x 3/16" h x 0.042" thk o/a; mts by elongated slot one end	Positions 0-1425		N17-T-350014-232	CTT	150291	150291	0-1421	1	1	1	-	-
0-1422	BUSHING: stainless steel; male and female; approx 3/16" OD x 1/8" ID x 0.049" thk o/a	Bushing for 0-1424		N17-T-350013-916	CTT	150298	150298	0-1422, 0-1426	4	1	2	-	-
0-1423	SLIDE: steel, nickel plated; irregular shape w/one ear and irregular shaped cutout one end, one side of cutout formed; approx 2 1/2" lg x 1 1/16" h x 3/32" wd o/a, 0.042" thk material; mts by hole between ear and small end	Positions 0-1425 and operates 0-1433		N17-T-350014-646	CTT	150371	150371	0-1423	1	-	-	-	-
0-1424	PLATE: steel, nickel plated; approx 1 5/16" lg x 13/32" wd x 0.025" thk o/a; mts by 2 body holes; rounded 1 end, projection other end w/two body holes	Spaces 0-1423 and 0-1425 and anchor for 0-1427		N17-T-350014-163	CTT	150297	150297	0-1424	1	-	-	-	-
0-1425	FORK: steel, nickel plated; rounded one end, two prongs other end, pin welded to ctr; approx 1 3/8" lg x 5/16" h x 5/32" wd o/a, 0.042" thk material; mts by hole in rounded end	Operates 0-1341		N17-T-350014-164	CTT	150296	150296	0-1425	1	1	1	-	-
0-1426	Same as 0-1422	Bushing for 0-1425											
0-1427	Same as 0-127	Applies tension to 0-1428 or 0-1429											
0-1428	LEVER: steel, nickel plated; irregular shape w/two ears and cutout; approx 1 3/4" lg x 15/32" wd x 0.042" thk o/a; mts by body hole	Operates 0-1423 when H-1402 is in upper position		N17-T-350014-551	CTT	150593	150593	0-1428	1	-	-	-	-
0-1429	LEVER: steel, nickel plated; irregular shape w/2 ears and cutout; approx 2" lg x 1/2" wd x 0.042" thk o/a; mts by body hole	Operates 0-1421		N17-T-350014-550	CTT	150591	150591	0-1429, 0-1430	2	-	-	-	-

CHANGE

0-1430	Same as 0-1429	Operates 0-1423																		
0-1431	LEVER: steel, nickel plated; irregular shape w/2 cutouts, 3 body ears and 1 formed ear; approx 1 3/4" lg x 5/8" wd x 1/4" h o/a, 0.042 thk material; mts by irregular shaped cutout, body hole near mtg cutout	Catch lock for 0-1414	N17-T-350014-321	CTT	150898	150898	0-1431	1	-	-	-	-	-	-	-	-	-	-	-	-
0-1432	SPRING: helical extension type; 0.012" diam music wire; approx 11/32" lg x 1/8" OD x 3/32" ID; approx 18 turns; hook term each end indexed 90°; mts by terms	Applies tension to function pawl	N17-T-350012-331	CTT	112629	112629	0-1432	8	1	2	-	-	-	-	-	-	-	-	-	-
0-1433	PAWL: steel, nickel plated; irregular shaped body has "V" notch on one rounded end, irregular shaped cutout near other end, formed ear near center; approx 2" lg x 5/8" wd x 1/8" dp o/a, 0.042" thk material; mts by elongated cutout near notched end	Operates 0-1428	N17-T-350014-200	CTT	150564	150564	0-1433, 0-1445 through 0-1454	11	-	-	-	-	-	-	-	-	-	-	-	-
0-1434	Same as 0-148	Applies tension to 0-1431, 0-1455 through 0-1460 or 0-1461																		
0-1435	PLATE: steel, nickel plated; irregular shape; approx 5/8" lg x 3/8" h x 0.042" thk o/a; mts by large rounded cutout; 3 cutouts in body	Anchors 0-1434 for 0-1455	N17-T-350014-206	CTT	150550	150550	0-1435, 0-1465, through 0-1470	7	-	-	-	-	-	-	-	-	-	-	-	-
0-1436	LATCH, lever: steel, nickel plated; irregular shape w/2 cutouts and 1 body ear; approx 13/16" lg x 11/16" wd x 0.042" thk o/a; mts by larger cutout; csk hole in arm	Locks 0-1431 and anchors 0-1434 for 0-1431	N17-T-350014-322	CTT	150899	150899	0-1436	1	-	-	-	-	-	-	-	-	-	-	-	-
0-1437	SHAFT: steel; approx 9 1/4" lg x 3/32" diam o/a; mts by ends	Stop and guide for function bars	N17-T-350014-212	CTT	150542	150542	0-1437	1	-	-	-	-	-	-	-	-	-	-	-	-
0-1438	SHAFT: steel; approx 9 7/16" lg x 3/32" diam o/a; mts by slot near ea end	Stop for function levers	N17-T-350014-208	CTT	150547	150547	0-1438, 0-1439	2	-	-	-	-	-	-	-	-	-	-	-	-
0-1439	Same as 0-1438	Support for 0-1462 through 0-1470, 0-1435 and 0-1436																		
0-1440	PLATE: steel, nickel plated; approx 1 3/4" lg x 3/8" wd x 0.065" thk o/a; mts by four body holes	Upper plate for signal bell contact mechanism	N17-T-350014-350	CTT	150963	150963	0-1440	1	-	-	-	-	-	-	-	-	-	-	-	-
0-1441	ECCENTRIC: steel, nickel plated finish; approx 5/16" OD x 1/8" ID x 1/16" thk o/a; mts by off ctr ID; slot across one end	Stop for 0-1490	N17-T-350014-348	CTT	150958	150958	0-1441	1	-	-	-	-	-	-	-	-	-	-	-	-
0-1442	PLATE, spacer: black bakelite; approx 1/2" wd x 1 3/4" lg x 1/16" thk o/a; mts by 4 body holes	Spaces and insulates E-1301 from 0-1440	N17-T-350014-199	CTT	150571	150571	0-1442	1	-	-	-	-	-	-	-	-	-	-	-	-
0-1443	BAR, contact mounting: black bakelite; approx 1 3/4" lg x 1/2" wd x 1/8" thk o/a; mts by 4 holes; 4 slots across width	Locates and spaces E-1301 from E-1302	N17-T-350014-198	CTT	150572	150572	0-1443	1	-	-	-	-	-	-	-	-	-	-	-	-

PARTS LISTS

TT-47/UG, TT-48/UG, TT-69/UG, TT-70/UG

NAVSHIPS 91393

Section

8

O-1430—O-1443

8-133

TABLE 8-4. COMBINED PARTS AND SPARE PARTS LIST

SYMBOL DESIG.	NAME OF PART AND DESCRIPTION	FUNCTION	JAN OR NAVY TYPE DESIGNATION	STANDARD NAVY STOCK NUMBER	MANUFAC- TURERS		TELETYPE PART NO.	ALL SYMBOL DESIGNATIONS INVOLVED	SPARE PARTS				
					CODE	DESIG.			TOTAL NO. PER EQUIP.	EQUIP.		STOCK	
										BOX	QUAN.	BOX	QUAN.
0-1444	BAR, contact mounting; black bakelite; approx 1 3/4" lg x 1/2" wd x 1/16" thk o/a; mts by 4 holes, 4 slots across width	Locates and spaces E-1302 from A-1315		N17-T-350014-197	GTT	150573	150573	0-1444	1	-	-	-	-
0-1445	Same as 0-1433	Operates 0-1429											
0-1446	Same as 0-1433	Operates 0-1430											
0-1447	Same as 0-1433	Operates 0-1455											
0-1448	Same as 0-1433	Operates 0-1456											
0-1449	Same as 0-1433	Operates 0-1457											
0-1450	Same as 0-1433	Operates 0-1458											
0-1451	Same as 0-1433	Operates 0-1459											
0-1452	Same as 0-1433	Operates 0-1460											
0-1453	Same as 0-1433	Operates 0-1461											
0-1454	Same as 0-1433	Operates 0-1431											
0-1455	LEVER: steel, nickel plated; irregular shape w/2 ears and cutout; approx 1 3/4" lg x 1/2" wd x 0.042" thk o/a; mts by body hole	Operates automatic carriage return mechanism		N17-T-350013-882	GTT	150592	150592	0-1455 through 0-1461	7	-	-	-	-
0-1456	Same as 0-1455	Operates carriage return mechanism											
0-1457	Same as 0-1455	Operates I-752											
0-1458	Same as 0-1455	Operates keyboard lock mechanism											
0-1459	Same as 0-1455	Operates automatic line feed mechanism											
0-1460	Same as 0-1455	Operates line feed mechanism											
0-1461	Same as 0-1455	Operates space suppression mechanism on single line feed											
0-1465	Same as 0-1435	Anchors 0-1434 for 0-1456											
0-1466	Same as 0-1435	Anchors 0-1434 for 0-1457											
0-1467	Same as 0-1435	Anchors 0-1434 for 0-1458											
0-1468	Same as 0-1435	Anchors 0-1434 for 0-1459											
0-1469	Same as 0-1435	Anchors 0-1434 for 0-1460											

8-134

CHANGE 1

## PARTS LISTS

## NAVSHPs 91393

TT-47/UG, TT-48/UG, TT-69/UG, TT-70/UG

Section 8  
O-1470—O-1486

0-1470	Same as 0-1435	Anchors 0-1434 for 0-1461																		
0-1471	BAR: steel, nickel plated; irregular shape, one end pointed, other end squared shape; approx 3 1/2" lg x 1/2" wd x 0.042" thk o/a; mts by 2 parts of body	Operates 0-1333	N17-T-350013-979	CTT	150516	150516	0-1471 through 0-1476	6	-	-	-	-	-	-	-	-	-	-	-	-
0-1472	Same as 0-1471	Operates 0-1334																		
0-1473	Same as 0-1471	Operates 0-1335																		
0-1474	Same as 0-1471	Operates 0-1336																		
0-1475	Same as 0-1471	Operates 0-1337																		
0-1476	Same as 0-1471	Operates 0-1338																		
0-1477	SPRING: flat type; nickel silver; approx 1 1/16" lg x 17/32" h x 1/8" wd o/a, 0.012" thk material; mts by ends; curved surface w/2 cutouts on ends	Applies pressure to E-1304 and E-1305	N17-T-350013-741	CTT	151607	151607	0-1477	1	1	2	-	-	-	-	-	-	-	-	-	-
0-1478	CORE, magnet: permalloy; c/o 7 lg laminations and 2 short laminations ea side; approx 2 5/16" lg x 9/16" wd x 9/16" h o/a; mts by 2 elongated slots; riveted in 3 places	Core for E-1304 or E-1305	N17-T-350014-680	CTT	150437	150437	0-1478	2	-	-	-	-	-	-	-	-	-	-	-	-
0-1479	YOKE, armature: Norway iron, nickel plated; approx 1 5/16" lg x 3/8" h x 1/8" thk o/a; mts by slot near ea end	Ties the two 0-1478's together	N17-T-350014-700	CTT	150463	150463	0-1479	2	-	-	-	-	-	-	-	-	-	-	-	-
0-1480	PLATE, stop: stainless steel; irregular "Y" shape, arms rounded at end, stem rectangular shape; approx 1 1/4" lg x 7/8" h x 0.031" thk o/a; mts by body hole in ea rounded end	Stop for E-1308	N17-T-350014-693	CTT	150455	150455	0-1480	1	-	-	-	-	-	-	-	-	-	-	-	-
0-1481	SPACER: stainless steel; approx 1/4" OD x 1/8" ID x 0.072" thk o/a; mts by ID	Spaces E-1308 from A-1320	N17-T-350013-749	CTT	151624	151624	0-1481	2	-	-	-	-	-	-	-	-	-	-	-	-
0-1482	SPACER: steel, nickel plated; approx 9/32" OD x 1/8" ID x 3/32" thk; mts by ID	Spaces 0-1485 from A-1321	N17-T-350012-990	CTT	125452	125452	0-1482	1	1	1	-	-	-	-	-	-	-	-	-	-
0-1483	SPRING: helical extension type 0.020" diam music wire; approx 9/16" lg x 5/32" OD o/a; approx 16 turns; hook terms; indexed 90°; mts by terms	Applies tension to E-1308	N17-T-350014-900	CTT	151715	151715	0-1483	1	1	1	-	-	-	-	-	-	-	-	-	-
0-1484	ECCENTRIC: steel, nickel plated; approx 1/4" lg x 3/8" OD x 1/8" ID o/a; mts by off ctr ID; slot across one end	Adjustable stop for 0-1485	N17-T-350014-346	CTT	150952	150952	0-1484	1	1	1	-	-	-	-	-	-	-	-	-	-
0-1485	PLATE: steel, nickel plated; irregular "L" shape w/"V" notch one end; approx 3/4" lg x 1/2" wd x 0.050" thk o/a; mts by body holes in corner of "L"	Adjusts tension of 0-1483	N17-T-350014-345	CTT	150946	150946	0-1485	1	-	-	-	-	-	-	-	-	-	-	-	-
0-1486	SHIM: steel; approx 5/16" OD x 5/32" ID x 0.004" thk o/a; mts by ID	Spaces H-1521 and 0-1492	N17-T-350002-349	CTT	82392	82392	0-1486, 0-1499	16	1	4	-	-	-	-	-	-	-	-	-	-

CHANGE 1

8-135



8-136

CHANGE 1

TABLE 8-4. COMBINED PARTS AND SPARE PARTS LIST

PARTS										SPARE PARTS				
SYMBOL DESIG.	NAME OF PART AND DESCRIPTION	FUNCTION	JAN OR NAVY TYPE DESIGNATION	STANDARD NAVY STOCK NUMBER	MANUFACTURERS		TELETYPE PART NO.	ALL SYMBOL DESIGNATIONS INVOLVED	TOTAL NO. PER EQUIP.	EQUIP.		STOCK		
					WH CODE	DESIG.				BOX	QUAN.	BOX	QUAN.	
0-1487	WASHER, felt: hard, white felt; round, approx 1/2" OD x 5/16" ID x 0.055" thk o/a	Lubricates H-1521		N17-T-350014-360	CTT	150990	150990	0-1487, 0-2102	2	-	-	-	-	
0-1488	SPRING: helical extension type; 0.024" diam music wire; approx 3/4" lg x 3/16" OD x 1/8" ID o/a; approx 15 turns; parallel hook term ea end; mts by terms	Applies tension to H-1521		N17-T-350006-864	CTT	41382	41382	0-1488	1	-	-	-	-	
0-1489	BUSHING: steel, nickel plated; male; approx 9/16" lg x 3/8" across flats o/a, body end threaded w/1/4" - 32 thd c/o body, slot, head slot and shank	Swivel for H-1521		N17-T-350014-698	CTT	150460	150460	0-1489	1	-	-	-	-	
0-1490	ARM: steel, nickel plated; curved body, one end rounded w/ear, other end formed; approx 1 7/16" h x 1 1/2" lg x 7/8" wd o/a, 0.042" thk material; mts by stud welded to rounded end	Stops selector clutch in stop position through 0-1749 and mounts 0-1492, H-1521, 0-1489, 0-1495 and 0-1497		N17-T-350014-546	CTT	150488	150488	0-1490	1	1	1	-	-	
0-1491	SPRING: helical extension type; 0.026" diam music wire; approx 3/4" lg x 5/32" OD o/a; 19 turns; parallel hook term ea end; mts by terms	Applies tension to 0-1490		N17-T-350014-894	CTT	49313	49313	0-1491	1	-	-	-	-	
0-1492	See 0-2131													
0-1493	See 0-2131													
0-1494	Same as 0-117	Applies tension to 0-1495												
0-1495	POINTER: steel, nickel plated; irregular shape w/three formed ears in cutout, two body ears and arm w/formed ear; approx 2 11/16" lg x 2" h x 11/16" wd o/a, 0.050" thk material; mts by elongated curved slot in approx ctr of body; bushing welded to arm, body hole in rounded ear	Operates adjustment of 0-1490 and associated parts		N17-T-350014-219	CTT	150528	150528	0-1495	1	-	-	-	-	
0-1496	PLATE: steel, nickel plated; irregular semi-circular shape w/rounded cutout one side, ear one end, arm on other; approx 3 5/8" lg x 2 1/8" wd x 0.065" thk o/a; mts by body hole in ear and arm; numerals "0, 20, 40, 60, 80, 100, 120" stamped on ear side marked off by scribed lines; 3 elongated slots and 1 body hole	Adjustment scale for 0-1495		N17-T-350014-221	CTT	150526	150526	0-1496	1	-	-	-	-	
0-1497	SPACER: steel, nickel plated; approx 1/2" OD x 1/4" ID x 3/32" thk o/a; mts by ID; extruded around ID	Guides 0-1495 in conjunction with 0-1496		N17-T-350013-918	CTT	150467	150467	0-1497	1	-	-	-	-	

8 Section  
O-1487—O-1497

TT-47/UG, TT-48/UG, TT-69/UG, TT-70/UG

NAVSHIPS 91393

PARTS LISTS

## PARTS LISTS

## NAVSHIPS 91393

TT-47/UG, TT-48/UG, TT-69/UG, TT-70/UG

Section 8  
O-1498—O-1513

0-1498	WASHER, felt; hard, white felt; round, approx 9/16" OD x 11/32" ID x 1/16" thk o/a	Lubricates 0-1492	N17-T-350014-361	CTT	150991	150991	0-1498	1	-	-	-	-	-
0-1499	Same as 0-1486	Spaces H-1482 and 0-1492											
0-1500	LEVER: steel, nickel plated; irregular shaped and curved, formed ear one end, body ear near ctr; approx 2 1/4" lg x 5/8" h x 1/16" wd o/a, 0.042" thk material; mts by rounded cutout near one end; irregular cutout in curved end	Operates 0-1493 and locks E-1308 in unattracted position	N17-T-350014-544	CTT	150485	150485	0-1500	1	1	1	-	-	-
0-1501	SPRING: helical extension type; 0.012" diam music wire; approx 5/8" lg x 3/32" OD o/a; approx 32 turns; hook terms, indexed 90°; mts by terms	Applies tension to 0-1500	N17-T-350014-888	CTT	151714	151714	0-1501	1	1	1	-	-	-
0-1502	GUIDE: steel, nickel plated; hex head and body w/8 slots irregularly spaced, short shank ea end; approx 1 1/4" lg x 5/16" across flats o/a; mts by tapped holes in ea end	Swivel for 0-1500, 0-1503 and 0-1505 through 0-1509	N17-T-350014-259	CTT	150469	150469	0-1502	1	-	-	-	-	-
0-1503	LEVER: steel, nickel plated; small end rounded two irregular shaped ears and two formed ears on sides; approx 2 1/16" lg x 1 1/8" h x 11/16" wd o/a, 0.042" thk material; mts by curved cutout in wd end; two csk holes near narrow end	Operates 0-1505 through 0-1509 and locks E-1308 in attracted position	N17-T-350013-983	CTT	150486	150486	0-1503	1	1	1	-	-	-
0-1504	SPRING: helical extension type; 0.009" diam music wire; approx 9/16" lg x 3/32" OD o/a; approx 45 turns; parallel hook term ea end; mts by terms	Applies tension to 0-1505, 0-1506, 0-1507, 0-1508 or 0-1509	N17-T-350014-430	CTT	151103	151103	0-1504	5	1	2	-	-	-
0-1505	LEVER: steel, nickel plated; irregular shape, one end has elongated cutout, other end irregularly cutout, rounded ear and elongated arm on one side; approx 2" lg x 3/4" wd x 0.042" thk o/a; mts by elongated cutout; elongated arm has csk hole near end	Operates 0-1521	N17-T-350014-223	CTT	150520	150520	0-1505 through 0-1509	5	1	2	-	-	-
0-1506	Same as 0-1505	Operates 0-1522											
0-1507	Same as 0-1505	Operates 0-1523											
0-1508	Same as 0-1505	Operates 0-1524											
0-1509	Same as 0-1505	Operates 0-1525											
0-1510	GUIDE: steel, nickel plated; irregular "L" shape w/curved ear near one end; approx 3/4" lg x 21/32" wd x 0.050" thk; mts by two body holes	Guide for 0-1521 and 0-1505	N17-T-350014-697	CTT	150459	150459	0-1510 through 0-1513	4	-	-	-	-	-
0-1511	Same as 0-1510	Guide for 0-1523, 0-1507 and 0-1500											
0-1512	Same as 0-1510	Guide for 0-1500 and 0-1503											
0-1513	Same as 0-1510	Guide for 0-1503, 0-1519, and 0-1508											

CHANGE 1

8-137

8-138

CHANGE 1

TABLE 8-4. COMBINED PARTS AND SPARE PARTS LIST

PARTS										SPARE PARTS				
SYMBOL DESIG.	NAME OF PART AND DESCRIPTION	FUNCTION	JAN OR NAVY TYPE DESIGNATION	STANDARD NAVY STOCK NUMBER	MANUFAC- TURERS		TELETYPE PART NO.	ALL SYMBOL DESIGNATIONS INVOLVED	TOTAL NO. PER EQUIP.	EQUIP.		STOCK		
					CODE	DESIG.				BOX	QUAN.	BOX	QUAN.	QUAN.
0-1514	SPRING: helical extension type; 0.008" diam music wire; approx 17/32" lg x 3/32" OD x 1/16" ID o/a; approx 40 turns; parallel hook term ea end; mts by terms	Applies tension to 0-1521, 0-1522, 0-1523, 0-1524 or 0-1525		N17-S-46759-6345	CTT	150048	150048	0-1514	5	1	2	-	-	-
0-1515	GUIDE: steel, nickel plated; irregular "I" shape w/curved ear tapered at and near one end; approx 3/4" lg x 21/32" wd x 0.050 thk; mts by two body holes	Guide for 0-1521, 0-1522, 0-1505 and 0-1506		N17-T-350014-696	CTT	150458	150458	0-1515 through 0-1520	6	-	-	-	-	-
0-1516	Same as 0-1515	Guide for 0-1522, 0-152., 0-1506 and 0-1507												
0-1517	Same as 0-1515	Guide for 0-1524, 0-1525, 0-1508 and 0-1509												
0-1518	Same as 0-1515	Guide for 0-1525 and 0-1509												
0-1519	Same as 0-1515	Guide for 0-1526												
0-1520	Same as 0-1515	Guide for 0-1526												
0-1521	LEVER: steel, nickel plated; "U" shaped one end w/notched ear on one side; approx 1 19/32" lg x 3/4" wd 0.042" thk o/a; mts by slot formed by "U"	Operates 0-2113		N17-T-350014-866	CTT	150497	150497	0-1521 through 0-1525	5	1	2	-	-	-
0-1522	Same as 0-1521	Operates 0-2112												
0-1523	Same as 0-1521	Operates 0-2111												
0-1524	Same as 0-1521	Operates 0-2110												
0-1525	Same as 0-1521	Operates 0-2109												
0-1526	BAIL: steel, nickel plated; "U" shaped w/lg irregular curved arm extending down from one side; approx 2 3/32" lg x 19/32" h x 27/32" wd o/a, material 0.042" thk; mts by two holes in line inside of "U"	Operates 0-1521 through 0-1525		N17-T-350013-981	CTT	150499	150499	0-1526	1	1	1	-	-	-
0-1527	ARM: steel, nickel plated; both ends rounded, rounded arm near ctr w/elongated ear; approx 1 23/32" lg x 5/8" wd, material 0.042" thk; mts by body holes in ea end; body hole in arm	Adjustment plate for A-1321		N17-T-350014-687	CTT	150445	150445	0-1527, 0-1817	2	-	-	-	-	-
0-1528	SPRING: helical extension type; 0.012" diam music wire; approx 15/32" lg x 5/32" OD x 1/8" ID o/a; approx 17 turns; parallel hook term ea end; mts by terms	Applies tension to 0-1503		N17-T-350006-500	CTT	78533	78533	0-1528	1	1	1	-	-	-

8 Section  
O-1514—O-1528

TT-47/UG, TT-48/UG, TT-69/UG, TT-70/UG

NAVSHIPS 91393

PARTS LISTS

0-1529	PLATE: steel, nickel plated; irregular shape w/ears and cutouts irregularly spaced; approx 5 1/16" lg x 3 11/16" wd x 0.065" thk o/a; mts by three body holes irregularly spaced; 9 body holes and 7 tapped holes irregularly spaced	Mounts range scale and selector mechanism	N17-T-350014-226	CTT	150517	150517	0-1529	1	-	-	-	-
0-1530	BRACKET: irregular shape, formed both ends, cutout one side w/formed ear; steel, nickel plated; approx 2 15/16" lg x 1 1/2" h x 1" wd o/a, 0.072" thk material; mts by tapped hole near ea end; body hole in ea formed end	Operates 0-1532 and 0-1555	N17-T-350013-857	CTT	150245	150245	0-1530	1	-	-	-	-
0-1532	LINK: steel, nickel plated; narrow ctr w/two rounded ends, one end cut flat on side; approx 1 3/16" lg x 1/2" wd x 3/16" h o/a, 0.065" thk material; mts by ID of hub welded at ea end	Link for 0-1530 and 0-1541	N17-T-350013-967	CTT	150247	150247	0-1532, 0-1555	2	-	-	-	-
0-1533	Same as 0-103	Lubricates 0-1534										
0-1534	LINK, drive: irregular shape, c/o two links bell crank, arm, lever and two hubs welded and riveted together, two ears and two wings irregularly located; approx 4 3/16" lg x 11/16" h x 7/16" wd o/a; mts by ID of three hubs; RH mtg, body hole at end of arm	Operates 0-1662	N17-T-350013-965	CTT	150240	150240	0-1534	1	1	1	-	-
0-1535	BUSHING: steel; male; approx 3/16" OD x 1/8" ID x 9/32" lg o/a	Bearing for 0-1534	N17-T-350014-138	CTT	150218	150218	0-1535, 0-1553	2	-	-	-	-
0-1536	SPRING: torsion type; 0.016" diam music wire; approx 3/8" lg x 7/32" OD x 3/16" ID o/a; 12 turns; LH turns; 1 hook and 1 stright end; mts by ends	Applies tension to 0-1540	N17-T-350014-203	CTT	150559	150559	0-1536	1	1	1	-	-
0-1537	Same as 0-255	Lubricates 0-1534										
0-1538	SPRING: helical extension type; 0.024" diam music wire; approx 3/4" lg x 1/4" OD x 3/16" ID o/a; approx 16 turns; parallel hook term ea end; mts by terms	Applies tension to 0-1534	N17-T-350013-620	CTT	88891	88891	0-1538, 0-1551	2	1	1	-	-
0-1539	WICK: lubricating wick; hard white felt; 5/8" lg x 1/8" diam o/a	Lubricates 0-1538	N17-T-350001-968	CTT	75226	75226	0-1539, 0-1552, 0-1923, 0-2002	4	1	2	-	-
0-1540	BAIL: steel, nickel plated; irregular shaped and formed body w/two wings forming "U" on sides; approx 1" lg x 5/8" h x 1/2" wd o/a, 0.035" thk material; mts by two holes in line in sides of "U"; RH mtg	Operates 0-1577	N17-T-350014-272	CTT	150777	150777	0-1540	1	-	-	-	-
0-1541	BAIL: steel, nickel plated; irregular shape, formed arm w/tapped hole at ea end, 2 arms on ctr of 1 side w/cutout w/rounded end between, 2 body ears w/stud butt welded to ea, 2 formed ears w/tapped hole in ea, 2 studs butt welded to body; approx 4 23/32" lg x 2 15/16" h x 1 3/32" wd o/a, 0.095" thk material; mts by body hole near ea end arm	Operates A-1316, 0-1534 and 0-1550	N17-T-350014-528	CTT	150263	150263	0-1541	1	-	-	-	-

CHANGE 1

8-139

8-140

CHANGE 1

TABLE 8-4. COMBINED PARTS AND SPARE PARTS LIST

SYMBOL DESIG.	NAME OF PART AND DESCRIPTION	FUNCTION	JAN OR NAVY TYPE DESIGNATION	STANDARD NAVY STOCK NUMBER	MANUFACTURERS		TELETYPE PART NO.	ALL SYMBOL DESIGNATIONS INVOLVED	TOTAL NO. PER EQUIP.	SPARE PARTS				
					CODE	DESIG.				EQUIP.		STOCK		
										BOX	QUAN.	BOX	QUAN.	
0-1542	Same as 0-1311	Lubricates 0-1545												
0-1543	SPRING: torsion type; 0.016" diam wire; approx 3/8" lg x 7/32" OD x 3/16" ID o/a; 12 turns; RH turns; one straight and one hook end; mts by ends	Applies tension to 0-1544		N17-T-350014-204	CTT	150558	150558	0-1543	1	1	1	-	-	
0-1544	BAIL: steel, nickel plated; irregularly shaped and formed, two rounded arms formed to "U" shape in approx ctr; approx 13/16" lg x 15/16" h x 3/8" wd o/a, 0.035" thk material; mts by two holes in line in sides of "U"	Operates 0-1574		N17-T-350014-149	CTT	150208	150208	0-1544	1	-	-	-	-	
0-1545	LEVER: steel, nickel plated; irregular shape w/formed ear w/"V" notch; approx 3 1/8" lg x 1 1/4" h x 1/4" wd o/a, 0.050" thk material; mts by elongated cutout in one end	Locks 0-1564		N17-T-350014-271	CTT	150776	150776	0-1545	1	-	-	-	-	
0-1546	SPRING: helical extension type; 0.029" diam music wire; approx 1 1/2" lg x 3/16" OD o/a; approx 39 turns; parallel loop terminals; mts by terminals	Applies tension to 0-1545 and 0-1541		N17-T-350002-774	CTT	86835	86835	0-1546	1	1	1	-	-	
0-1547	WICK: lubricating wick; soft white felt, w/o spring; approx 1 1/4" lg x 1/8" sq o/a	Lubricates 0-1546		N17-T-350013-906	WESTERN FELT	F-10-1117	105028	0-1547	1	1	1	-	-	
0-1548	Same as 0-103	Lubricates 0-1550												
0-1549	Same as 0-255	Lubricates 0-1550												
0-1550	LINK, drive: irregular shape, c/o two links, bell crank, arm, lever and two hubs welded and riveted together, two wings and two ears irregularly located; approx 4 3/16" lg x 11/16" h x 7/16" wd o/a; mts by ID of three hubs; LH mtg, body hole at end of arm	Operates 0-1662		N17-T-350013-964	CTT	150239	150239	0-1550	1	1	1	-	-	
0-1551	Same as 0-1538	Applies tension to 0-1550												
0-1552	Same as 0-1539	Lubricates 0-1551												
0-1553	Same as 0-1535	Bearing for 0-1550												
0-1554	PLATE: steel, nickel plated; both ends rounded; approx 1 5/8" lg x 9/32" wd x 0.042" thk o/a; mts by 3 body holes	Clamps 0-1534 and 0-1550 to 0-1662		N17-T-350013-951	CTT	150740	150740	0-1554	1	-	-	-	-	
0-1555	Same as 0-1532	Link for 0-1530 and 0-1531												
0-1556	Same as 0-308	Lubricates 0-1562												
0-1557	Same as 0-103	Lubricates 0-1550												

8 Section  
O-1542—O-1557

TT-47/UG, TT-48/UG, TT-69/UG, TT-70/UG

NAVSHIPS 91393

PARTS LISTS

CHANGE 1

0-1558	POST, bearing: steel, nickel plated; stud w/ slot welded to round end of base, cutout on ea side in ctr of base; approx 1 7/8" lg x 7/8" h x 5/16" wd o/a; mts by tapped hole and elongated slot in base; slot cut in body of stud	Pivot for and mts 0-1550	N17-T-350014-344	CTT	150939	150939	0-1558, 0-1559	2	-	-	-	-	-
0-1559	Same as 0-1558	Pivot for and mts 0-1534											
0-1560	STRIP: steel, nickel plated; "U" shape; approx 1 15/16" lg x 3/8" wd x 1/8" h o/a, material 0.035 thk; mts by two elongated holes in bottom of "U"	Ties 0-1558 and 0-1559	N17-T-350013-750	CTT	151625	151625	0-1560	1	-	-	-	-	-
0-1561	Same as 0-103	Lubricates 0-1534											
0-1562	ROLLER: steel; ctr separated from larger diam ends by two slots; approx 3/16" lg x 7/32" OD x 3/32" ID o/a; mts by ID	Roller for 0-1564	N17-T-350013-956	CTT	150753	150753	0-1562	1	1	1	-	-	-
0-1563	ROLLER: steel; approx 1/8" lg x 5/32" OD x 3/32" ID o/a; mts by ID	Stop roller for 0-1545	N17-T-350014-148	CTT	150754	150754	0-1563	1	1	1	-	-	-
0-1564	ARM: steel, nickel plated; irregular shape w/elongated cutout in one end; approx 3 3/16" lg x 1/2" wd x 1/2" h o/a, 0.065" thk material; mts by ID of hub welded to round end; hole near cutout	Positions H-1554	N17-T-350014-554	CTT	150757	150757	0-1564	1	-	-	-	-	-
0-1565	BLOCK, guide: oilite; approx 3/8" lg x 5/16" wd x 7/32" h o/a; mts by hole in ctr; slot across two sides	Guide for 0-1541	N17-T-350014-254	CTT	150215	150215	0-1565	1	-	-	-	-	-
0-1566	RETAINER, oil: hard, white felt; approx 9/16" sq x 1/16" thk o/a; mts by squared cutout	Lubricates 0-1541	N17-T-350014-146	CTT	150232	150232	0-1566	1	1	1	-	-	-
0-1567	PULLEY: molded sirvene w/bronze hub; one side flat w/cutout in ctr, other side extruded in ctr; approx 1" OD x 7/32" ID x 3/16" wd o/a; mts by ID; groove in width around circum	Roller guide for W-1304	N17-T-350014-839	CTT	150758	150758	0-1567	1	1	2	-	-	-
0-1568	BALL: steel, nickel plated; "U" shaped, formed ear one side, tapped hole other side, csk hole in bottom; approx 1 9/16" lg x 1 5/32" wd x 1/2" h o/a, 0.065" thk material; mts by two holes in line at ends of "U"	Mounts and positions 0-1567	N17-T-350014-852	CTT	151699	151699	0-1568	1	-	-	-	-	-
0-1569	GUIDE: steel, nickel plated; irregular shape w/three slots in one end; approx 1" lg x 7/16" h x 5/16" wd o/a; mts by two tapped holes; three pins pressed into body	Guide for and mts 0-1570 to 0-1572	N17-T-350013-601	CTT	150738	150738	0-1569	1	-	-	-	-	-
0-1570	SLIDE: steel, nickel plated finish; slot open at top end, ear on top and rounded ear with "V" notch one side, oblong ears near base both sides; approx 7/8" lg x 7/8" h x 1/16" wd o/a, 0.059" thk material; mts by slots	Stop for 0-1534 to 0-1550	N17-T-350013-950	CTT	150733	150733	0-1570	1	-	-	-	-	-

PARTS LISTS

TT-47/UG, TT-48/UG, TT-69/UG, TT-70/UG

NAVSHIPS 91393

Section 8  
O-1558-O-1570

8-141

8-142

TABLE 8-4. COMBINED PARTS AND SPARE PARTS LIST

SYMBOL DESIG.	NAME OF PART AND DESCRIPTION	FUNCTION	JAN OR NAVY TYPE DESIGNATION	STANDARD NAVY STOCK NUMBER	MANUFAC- TURERS		TELETYPE PART NO.	ALL SYMBOL DESIGNATIONS INVOLVED	SPARE PARTS				
					CODE	DESIG.			TOTAL NO. PER EQUIP.	EQUIP.		STOCK	
										BOX	QUAN.	BOX	QUAN.
0-1571	SLIDE: steel, nickel plated finish; slot open at top end, rounded ear with "V" notch, and oblong ears near base and 2 formed ears at base; approx 1 1/8" lg x 7/8" wd x 1/4" dp o/a, 0.047" thk material; mts by slot	Stop for 0-1534 and 0-1550		N17-T-350013-948	CTT	150731	150731	0-1571	1	-	-	-	-
0-1572	SLIDE: steel, nickel plated finish; slot open at top end, ear near top and rounded ear with "V" notch one side, squared ears near base on both sides; approx 7/8" lg x 5/8" wd x 1/16" thk o/a, 0.059" thk material; mts by slots	Stop for 0-1534 and 0-1550		N17-T-350013-949	CTT	150732	150732	0-1572	1	-	-	-	-
0-1573	SPRING: helical compression type; 0.020" music wire; approx 5/16" lg x 9/32" OD x 1/4" ID; 5 turns; RH; closed ends	Applies pressure to 0-1574		N17-S-46657-8041	CTT	109839	109839	0-1573, 0-1576	2	1	1	-	-
0-1574	SLIDE: steel, nickel plated; "T" shape; approx 1 7/8" lg x 1 1/2" wd x 0.045" thk o/a; mts by elongated slot	Operates 0-1648		N17-T-350013-596	CTT	150694	150694	0-1574, 0-1577	2	-	-	-	-
0-1575	Same as 0-196	Lubricates 0-1574											
0-1576	Same as 0-1573	Applies pressure to 0-1574											
0-1577	Same as 0-1574	Operates 0-1664											
0-1578	Same as 0-196	Lubricates 0-1577											
0-1579	Same as 0-1352	Roller for 0-1580											
0-1580	SLIDE, shift: steel, nickel plated; irregular shape, rounded 1 end, other end formed, stud riveted near ea end; approx 4 5/8" lg x 9/16" h x 5/8" wd o/a, 0.035" thk material; mts by 2 elongated holes	Operates 0-1574 and 0-1577		N17-T-350014-629	CTT	150347	150347	0-1580	1	-	-	-	-
0-1581	BAIL: steel, nickel plated; formed at ends and 2 notches on side; approx 3 5/8" lg x 3/4" h x 3/16" wd o/a, 0.035" thk material; mts by 2 body holes	Retaining plate for 0-1580 and stop for 0-1534 and 0-1550		N17-T-350013-602	CTT	150744	150744	0-1581	1	-	-	-	-
0-1582	BRACKET: irregular shape, formed in approx ctr, stud welded to narrow end; steel, nickel plated; approx 1" lg x 7/8" h x 1 1/8" wd o/a, 0.065" thk material; mts by elongated hole and body hole in wd end	Pivot for 0-1595 and 0-1593		N17-T-350014-132	CTT	150181	150181	0-1582	1	-	-	-	-
0-1583	BUSHING: steel, nickel plated; male and female; approx 5/16" across flats x #6-40 tapped ID x 1/8" lg o/a, 3/16" diam body	Pivot for and locks 0-1585 to front plate		N17-T-350013-905	CTT	95827	95827	0-1583, 0-1966, 0-1971, 0-2015	5	1	1	-	-
0-1584	Same as 0-121	Applies tension to 0-1585											

CHANGE 1

8 Section  
0-1571-0-1584TT-47/UG, TT-48/UG, TT-69/UG, TT-70/UG  
NAVSHIPS 91393

PARTS LISTS

CHANGE 1

0-1585	BELL CRANK: steel, nickel plated; one end formed and pointed, other end rounded w/ curved arm formed at end, ear on side of body; approx 1 1/4" lg x 1" h x 7/8" wd o/a, 0.065" thk material; mts by hole in rounded end	Operates 0-1339	N17-T-350014-681	CTT	150438	150438	0-1585	1	-	-	-	-	-	-
0-1586	LINK: steel; c/o irregular shaped link w/formed ear riveted to "C" shaped bell crank formed at one end; approx 2 13/16" lg x 1 1/16" h x 1 1/16" wd o/a; mts by body hole in bell crank	Operates 0-1599 and 0-1602	N17-T-350014-133	CTT	150184	150184	0-1586	1	-	-	-	-	-	-
0-1587	Same as 0-1377	Pivot and bushing for 0-1586												
0-1588	SPRING: helical extension type; 0.012" diam music wire; approx 5/8" lg x 5/32" OD x 1/8" ID o/a; approx 25 turns; parallel hook term ea end; mts by terms	Applies tension to 0-1586	N17-T-350006-529	CTT	81731	81731	0-1588	1	1	1	-	-	-	-
0-1589	SLIDE, transfer: steel, nickel plated; irregular "U" shape w/two arms on one side, one arm irregular shaped and formed at end, circular cutout one end of base; approx 4 1/16" lg x 2 1/8" h x 1 1/16" wd o/a, 0.065" thk material; mts by two elongated slots in line in sides of "U"; two tapped holes in formed end of arm	Operates 0-1605 through 0-1608	N17-T-350014-836	CTT	150235	150235	0-1589	1	-	-	-	-	-	-
0-1590	ROLLER, bearing: steel; approx 1/8" thk x 3/8" OD x 1/4" ID; mts by ID	Roller for 0-1589	N17-T-350014-141	CTT	150233	150233	0-1590	1	-	-	-	-	-	-
0-1591	ROLLER, bearing: steel; approx 3/8" OD x 1/4" ID x 1/16" thk o/a; mts by ID	Roller for 0-1589	N17-T-350014-147	CTT	150234	150234	0-1591	1	-	-	-	-	-	-
0-1592	SPRING: helical extension type; 0.018" diam music wire; approx 1 15/16" lg x 7/32" OD x 3/16" ID o/a; approx 85 turns; hook terminals ea end; mts by terminals	Applies tension to 0-1589	N17-T-350014-215	CTT	150536	150536	0-1592	1	1	1	-	-	-	-
0-1593	PLATE: steel, nickel plated; irregular shape, rounded at wd end; approx 1" lg x 1/2" wd x 0.050" thk o/a; mts by hole in rounded end; elongated slot near mtg hole	Stop for 0-1689 and operates 0-1595	N17-T-350014-136	CTT	150194	150194	0-1593	1	-	-	-	-	-	-
0-1594	HUB: steel, nickel plated; c/o head, slot and body; approx 5/16" OD x 3/16" ID x 1/8" lg o/a; mts by ID	Bushing for 0-1593 and 0-1595	N17-T-350013-911	CTT	150193	150193	0-1594	1	-	-	-	-	-	-
0-1595	BAIL: steel, nickel plated; irregular "U" shape w/two arms on sides and formed ear on base; approx 1 3/8" lg x 5/8" h x 3/4" wd o/a; mts by two holes in line in sides; tapped hole in short arm, csk hole in ear	Latches 0-2046 and operates 0-1593	N17-T-350014-137	CTT	150196	150196	0-1595	1	-	-	-	-	-	-
0-1596	SPRING: helical extension type; 0.018" diam music wire; approx 13/16" lg x 1/4" OD x 7/32" ID; approx 24 turns; parallel hook term each end; mts by terms	Applies tension to 0-1595	N17-T-350012-702	CTT	125238	125238	0-1596	1	1	1	-	-	-	-

PARTS LISTS

TT-47/UG, TT-48/UG, TT-69/UG, TT-70/UG

NAVSHIPS 91393

Section 8  
O-1585-O-1596

8-143



TABLE 8-4. COMBINED PARTS AND SPARE PARTS LIST

SYMBOL DESIG.	NAME OF PART AND DESCRIPTION	FUNCTION	JAN OR NAVY TYPE DESIGNATION	STANDARD NAVY STOCK NUMBER	MANUFACTURERS		TELETYPE PART NO.	ALL SYMBOL DESIGNATIONS INVOLVED	TOTAL NO. PER EQUIP.	SPARE PARTS			
					CODE	DESIG.				EQUIP.		STOCK	
										BOX	QUAN.	BOX	QUAN.
0-1597	RETAINER: steel, nickel plated; approx 5/8" diam x 0.035" thk o/a; mts by 2 body holes	Retains 0-1598, 0-1599, 0-1601 and 0-1602 in position		N17-T-350014-143	CTT	150203	150203	0-1597	1	-	-	-	-
0-1598	ECCENTRIC: super oilite; curved extrusion around 1/2 circum; approx 19/32" OD x 5/32" ID x 3/32" thk o/a; mts by off ctr ID; body hole above and below mtg hole	Roller for 0-1599		N17-T-350014-144	CTT	150204	150204	0-1598, 0-1601	2	1	2	-	-
0-1599	PAWL: steel, nickel plated; irregular shape w/formed ear; approx 3 13/16" lg x 1 1/16" h x 1/8" wd o/a, 0.072" thk material; mts by large hole in round end; RH mtg, csk hole in formed ear	Operates 0-1691		N17-T-350014-865	CTT	150678	150678	0-1599	1	-	-	-	-
0-1600	SPRING: helical extension type; 0.014" diam music wire; approx 5/8" lg x 3/16" OD o/a; approx 19 turns; parallel hook terms; mts by terms	Applies tension to 0-1599		N17-T-350006-478	CTT	75229	75229	0-1600, 0-1603	2	1	1	-	-
0-1601	Same as 0-1598	Roller for 0-1602											
0-1602	PAWL: steel, nickel plated; irregular shape w/formed ear; approx 3 13/16" lg x 1 1/16" h x 1/8" wd o/a, 0.072" thk material; mts by large hole in round end; LH mtg; csk hole in formed ear	Operates 0-1691		N17-T-350014-553	CTT	150677	150677	0-1602	1	-	-	-	-
0-1603	Same as 0-1600	Applies tension to 0-1602											
0-1604	COLLAR: steel, nickel plated; approx 3/8" lg x 5/8" OD x 1/4" ID o/a; mts by ID; two tapped holes in ctr and one hole in side	Mounts 0-1597, 0-1598, 0-1599, 0-1601 and 0-1602 to 0-1612		N17-T-350013-936	CTT	150668	150668	0-1604	1	-	-	-	-
0-1605	RETAINER: bronze; approx 1 1/8" diam x 1/8" thk o/a; mts by two body holes; flanged circumference	Plunger for 0-1609		N17-T-350014-255	CTT	150229	150229	0-1605	1	-	-	-	-
0-1606	CUP, dash pot: molded sirvene; OD slanted; approx 1 1/8" OD x 3/16" thk o/a; mts by two holes; dished out from wider diam side	Valve for 0-1609		N17-T-350014-355	CTT	150975	150975	0-1606	1	1	1	-	-
0-1607	SPACER: aluminum, plain anodize; approx 1/4" OD x 1/8" ID x 0.087" thk o/a; mts by ID	Bushing for 0-1606		N17-T-350014-359	CTT	150987	150987	0-1607	2	-	-	-	-
0-1608	RETAINER: steel, nickel plated; approx 7/8" diam x 1/32" thk o/a; mts by two body holes	Retains 0-1605, 0-1606 and 0-1607 to 0-1589		N17-T-350013-914	CTT	150228	150228	0-1608	1	-	-	-	-

8-144

CHANGE 1

CHANGE 1

8-145

0-1609	CYLINDER: dash pot; aluminum; plain anodized; 1 1/8" ID through most of cylinder; approx 1 1/4" h x 1 3/8" wd x 1 15/16" lg o/a; mts by tapped hole in ea of 3 feet; body hole through closed end, tapped on one side, one body hole through inner wall and 2 body holes through outer wall	Slows up return of carriage	N17-T-350014-549	CTT	150538	150538	0-1609	1	-	-	-	-	-	-
0-1610	SHIM: steel; one end rounded; approx 7/8" lg x 3/8" h x 0.002" thk o/a; mts by body hole; cutout on side	Adjusting shim for 0-1614	N17-T-350013-937	CTT	150669	150669	0-1610	4	-	-	-	-	-	-
0-1611	SHIM: steel; approx 5/16" wd x 1/2" lg x 0.004" thk; mts by body hole in ctr	Adjusting shim for 0-1614	N17-T-350014-150	CTT	150670	150670	0-1611	4	-	-	-	-	-	-
0-1612	SHAFT: steel; slot one end between body and shoulder w/shank groove other end; approx 3 5/8" lg x 1/4" diam o/a; mts by shank; two tapped holes	Operates 0-1599 and 0-1602	N17-T-350013-938	CTT	150673	150673	0-1612	1	-	-	-	-	-	-
0-1613	GEAR: spur; steel, nickel plated; helical teeth; RH; 18 teeth; 22 pitch, 1.04" PD; approx 1 1/8" OD x 9/16" thk o/a; straight face; approx 7/16" diam hub; mts by ctb hole in hub side; "150202" stamped on face	Operates 0-1612	N17-T-350013-912	CTT	150202	150202	0-1613	1	-	-	-	-	-	-
0-1614	BEARING: aluminum, plain anodize; two wings w/round head and body; approx 2 1/4" lg x 1 3/8" wd x 1" h o/a; mts by tapped hole in each wing; bushing pressed in at ea end of ID, hole through side of body	Mounts 0-1612	N17-T-350013-591	CTT	150672	150672	0-1614	1	-	-	-	-	-	-
0-1615	LEVER: steel, nickel plated; irregular shape, "U" formed on end, irregularly formed other end, cutout w/notch near formed end; approx 2 9/16" lg x 13/16" h x 1 3/4" wd o/a, 0.050" thk material; mts by two holes in line in sides of "U"	Operates 0-1646	N17-T-350013-970	CTT	150259	150259	0-1615	1	-	-	-	-	-	-
0-1616	BUSHING: steel; male and female; approx 5/16" OD x 5/32" ID x 11/16" lg o/a, 7/32" body diam and 1/32" thk flange	Pivot for 0-1615	N17-T-350013-924	CTT	150746	150746	0-1616	1	-	-	-	-	-	-
0-1617	BELL CRANK: steel, nickel plated; circular shape w/two irregular shaped arms formed at ends, csk hole in longer arm; approx 9/16" lg x 1/2" wd x 1/8" h o/a; 0.028" thk material; mts by ID of hub welded to body; LH mtg	Operates 0-1570 and 0-1571	N17-T-350014-840	CTT	150770	150770	0-1617	1	-	-	-	-	-	-
0-1618	Same as 0-1301	Applies tension to 0-1619												
0-1619	BELL CRANK: steel nickel plated; circular shape w/two irregular shaped arms formed at ends, csk hole in longer arm; approx 9/16" lg x 1/2" wd x 1/8" h o/a, 0.028" thk material; mts by ID of hub welded to body; RH mtg	Operates 0-1572	N17-T-350014-841	CTT	150771	150771	0-1619	1	-	-	-	-	-	-
0-1620	Same as 0-1301	Applies tension to 0-1617												
0-1621	Same as 0-103	Lubricates 0-1617 and 0-1619												

PARTS LISTS

TT-47/UG, TT-48/UG, TT-69/UG, TT-70/UG

NAVSHIPS 91393

Section 8  
O-1609—O-1621

8-146

CHANGE 1

TABLE 8-4. COMBINED PARTS AND SPARE PARTS LIST

SYMBOL DESIG.	NAME OF PART AND DESCRIPTION	FUNCTION	JAN OR NAVY TYPE DESIGNATION	STANDARD NAVY STOCK NUMBER	MANUFACTURERS		TELETYPE PART NO.	ALL SYMBOL DESIGNATIONS INVOLVED	TOTAL NO. PER EQUIP.	SPARE PARTS			
					ID CODE	DESIG.				EQUIP.		STOCK	
										BOX	QUAN.	BOX	QUAN.
0-1622	PLATE: steel, nickel plated; approx 1 1/4" lg x 9/16" wd x 0.035" thk o/a; mts by two holes and elongated hole between holes	Guide for A-1316		N17-T-350014-286	CTT	150806	150806	0-1622, 0-1626	4	-	-	-	-
0-1623	SHIM: nickel silver; oblong shape; approx 13/16" lg x 5/16" wd x 0.012" thk o/a; mts by hole and elongated slot	Adjusting shim for 0-1622		N17-T-350014-285	CTT	150805	150805	0-1623, 0-1627	2	-	-	-	-
0-1624	RETAINER, oil: hard, white felt, approx 3/8" sq x 1/16" wd o/a	Lubricates A-1316		N17-T-350014-287	CTT	150807	150807	0-1624, 0-1628	2	-	-	-	-
0-1625	PLATE: steel, nickel plated; irregular shape w/two arms w/cutout in each and formed side; approx 15 3/8" lg x 3 1/2" h x 3/8" wd o/a, 0.050" thk material; mts by two large body holes; elongated slot in ea arm, two holes in one arm and three in other, eight small holes in body	Mounts A-1324, 0-1622, 0-1626, H-1701 and H-1724		N17-T-350013-578	CTT	150554	150554	0-1625	1	-	-	-	-
0-1626	Same as 0-1622	Guide for A-1316											
0-1627	Same as 0-1623	Adjusting shim for 0-1627											
0-1628	Same as 0-1624	Lubricates A-1316											
0-1629	LEVER: steel, nickel plated; irregular shape w/three arms, formed at ends; approx 1 3/8" h x 1 3/16" lg x 3/4" wd o/a, 0.050" thk material; mts by body hole near rounded p/o body	Controls adjustment of 0-1681		N17-T-350013-962	CTT	150237	150237	0-1629	1	-	-	-	-
0-1630	PULLEY: grooved; black bakelite; approx 1 3/8" OD x 7/32" ID x 3/16" thk o/a; one groove, 5/64" wd x 0.071" deep; mts by ID	Roller guide for W-1304		N17-T-350014-139	CTT	150224	150224	0-1630, 0-1637, 0-1667, 0-1679	4	1	2	-	-
0-1631	SLEEVE: steel, nickel plated; approx 5/16" OD x 1/8" ID x 1 1/32" lg o/a; mts by ID; slot between head and body	Guide for 0-1675 and spaces A-1324 and front plate		N17-T-350013-942	CTT	150709	150709	0-1631, 0-1636	2	-	-	-	-
0-1632	BLOCK, guide: super oilite; approx 3/4" lg x 1/2" wd x 1/4" thk o/a; mts by two body holes slot across width on bottom side	Guide for 0-1545		N17-T-350013-954	CTT	150751	150751	0-1632	1	-	-	-	-
0-1633	PLATE: steel, nickel plated; irregular shape; approx 3/4" lg x 1/2" h x 0.058" thk o/a; mts by two tapped holes	Retaining plate for 0-1545		N17-T-350013-953	CTT	150750	150750	0-1633	1	-	-	-	-
0-1634	WASHER, felt: hard, white felt, round, 3/8" ID x 9/16" OD x 3/32" thk	Lubricates 0-1630		N17-T-350013-628	CTT	90504	90504	0-1634, 0-1635, 0-1638, 0-2132	5	1	2	-	-

8 Section  
O-1622—O-1634

TT-47/UG, TT-48/UG, TT-69/UG, TT-70/UG

NAVSHIPS 91393

PARTS LISTS

CHANGE 1

8-147

0-1635	Same as 0-1634	Lubricates 0-1637																		
0-1636	Same as 0-1631	Guide for 0-1669 and spaces A-1324 and front plate																		
0-1637	Same as 0-1630	Roller guide for W-1304																		
0-1638	Same as 0-1634	Lubricates 0-1639, 0-1640 and 0-1646																		
0-1639	BAIL: steel, nickel plated; irregular "U" shape w/two "V" notches and roller mtd by pin riveted across inside of "U"; approx 1 1/16" lg x 3/8" h x 3/16" wd o/a, 0.035" thk material; mts by two cutouts and body near one end	Positions 0-1646	N17-T-350014-267	CTT	150772	150772	0-1639, 0-1640	2	-	-	-	-	-	-	-	-	-	-	-	-
0-1640	Same as 0-1639	Positions 0-1646																		
0-1641	SPRING: loop; 0.018" diam music wire; approx 3/4" lg x 5/8" wd x 1/2" h o/a; hook terminals; mts by hook terminals and cross piece of body	Applies tension to 0-1639 and 0-1640	N17-T-350014-347	CTT	150955	150955	0-1641	1	1	1	-	-	-	-	-	-	-	-	-	-
0-1642	SPRING: torsion type; 0.025" diam music wire; approx 1 1/4" lg x 5/16" wd x 3/16" h o/a; 2 1/2 turns; right hand; 1 straight and 1 "U" shaped end; mts by ends	Applies pressure to 0-1526	N17-T-350014-596	CTT	151701	151701	0-1642	1	-	-	-	-	-	-	-	-	-	-	-	-
0-1643	PLATE: steel, nickel plated; irregularly curved shape w/2 teeth one side; approx 2 1/32" h x 2 1/32" lg x 1/16" wd o/a, 0.035" thk material; mts by 2 elongated slots; "L" shape cutout	Retaining plate for 0-1615	N17-T-350013-743	CTT	151609	151609	0-1643	1	-	-	-	-	-	-	-	-	-	-	-	-
0-1644	PLATE: steel, nickel plated; approx 9/16" lg x 3/16" wd x 0.065" thk o/a; mts by tapped hole near ea end	Holds 0-1643 to 0-1646	N17-T-350013-742	CTT	151608	151608	0-1644	1	-	-	-	-	-	-	-	-	-	-	-	-
0-1645	Same as 0-1301	Applies tension to 0-1671																		
0-1646	SLIDE: steel, nickel plated; irregular shape w/three cutouts and three ears; approx 7" lg x 1/2" wd x 0.035" thk o/a; mts by wd end and wd part of body near other end; has two large and three small holes, one elongated hole	Operates 0-1534 and 0-1550	N17-T-350014-268	CTT	150773	150773	0-1646	1	-	-	-	-	-	-	-	-	-	-	-	-
0-1647	GUIDE: steel, nickel plated; irregular shape w/formed ends and irregular shaped cutout; approx 2" lg x 1 1/4" wd x 7/8" h o/a; 0.065" thk material; mts by hole in one formed end and hole and elongated slot in other formed end; LH mtg, irregular shape, elongated hole in body	Guide for and mounts 0-1662	N17-T-350014-270	CTT	150775	150775	0-1647	1	-	-	-	-	-	-	-	-	-	-	-	-
0-1648	LINK: steel; irregular shape w/two body ears and two differently formed ears; approx 2 1/4" lg x 3/4" h x 1/2" wd o/a; mts by two tapped holes and ID of hub welded to link; spring post riveted to body ear of link, link riveted to plate through bushing in link, LH mtg	Operates 0-1680	N17-T-350013-598	CTT	150726	150726	0-1648	1	-	-	-	-	-	-	-	-	-	-	-	-

PARTS LISTS

TT-47/UG, TT-48/UG, TT-69/UG, TT-70/UG

NAVSHIPS 91393

Section 8  
O-1635—O-1648

8-148

TABLE 8-4. COMBINED PARTS AND SPARE PARTS LIST

SYMBOL DESIG.	NAME OF PART AND DESCRIPTION	FUNCTION	JAN OR NAVY TYPE DESIGNATION	STANDARD NAVY STOCK NUMBER	MANUFACTURERS		TELETYPE PART NO.	ALL SYMBOL DESIGNATIONS INVOLVED	TOTAL NO. PER EQUIP.	SPARE PARTS			
					MFG CODE	DESIG.				EQUIP.		STOCK	
										BOX	QUAN.	BOX	QUAN.
0-1650	SPRING: helical extension type; music wire; approx 1 3/16" lg x 3/16" OD o/a; approx 42 turns; hook terminals, indexed 90° mts by terminals	Applies tension to 0-1568		N17-T-350006-837	CTT	33828	33828	0-1650	1	1	1	-	-
0-1651	SPRING: torsion type, 0.022" diam music wire; approx 3/8" OD x 7/16" WD x 1/8" lg o/a; 3 turns; hook ends; mts by ends	Applies pressure to 0-1648 and 0-1657		N17-S-46846-1676	CTT	151698	151698	0-1651, 0-1660	1	1	3	-	-
0-1652	Same as 0-250	Applies tension to left slide on 0-1662											
0-1653	OILER, felt: hard, white felt, approx 1/2" lg x 1/4" wd x 1/16" thk o/a; mts by elongated notch in ea end	Lubricates 0-1622		N17-T-350014-337	CTT	150929	150929	0-1653	2	1	1	-	-
0-1654	Same as 0-1363	Lubricates 0-1650											
0-1655	OILER, felt: hard, white felt; approx 5/8" lg x 1/4" wd x 1/16" thk o/a, mts by elongated notch in ea end	Lubricates 0-1646		N17-T-350014-336	CTT	150927	150927	0-1655	2	1	1	-	-
0-1656	Same as 0-250	Applies tension to right slide on 0-1662											
0-1657	LINK: steel, nickel plated; irregular shape w/round ear w/spring post riveted on and formed curved ear, stud riveted to small end of link approx 1 1/16" lg x 1/2" h x 3/8" wd o/a, 0.042" thk material; mts by hole in large end; RH mtg	Operates 0-1648		N17-T-350014-266	CTT	150692	150692	0-1657	1	-	-	-	-
0-1659	LINK: steel, nickel plated; irregular shape w/round ear w/spring post riveted on and formed curved ear, stud riveted to smaller end; approx 1 1/16" lg x 1/2" h x 3/8" wd o/a, 0.042" thk material; mts by hole in large end; LH mtg	Operates 0-1664		N17-T-350014-262	CTT	150691	150691	0-1659	1	-	-	-	-
0-1660	Same as 0-1651	Applies pressure to 0-1659											
0-1662	SLIDE: steel, nickel plated; irregular shape w/identical ends and formed bottom slide mtd on ea end of large ctr cutout by guide w/formed ends hooked in large cutout and small slot on ea end, bell crank riveted above ea slide w/springs connected to ctr ear on top of body, pin riveted next to ea bell crank, 2 studs near ea pin; approx 6 1/4" lg x 1 1/4" h x 1/2" wd o/a; mts by identical elongated ends; 5 body holes	Operates 0-1657 and 0-1660		N17-T-350014-845	CTT	150953	150953	0-1662	1	-	-	-	-

CHANGE 1

8 Section  
0-1650-0-1662NAVSHIPS 91393  
TT-47/UG, TT-48/UG, TT-69/UG, TT-70/UG

PARTS LISTS

CHANGE 1

8-149

0-1663	GUIDE: steel, nickel plated; irregular shape w/formed end, elongated cutout in one end, formed wing and irregular shaped cutout near wing; approx 2 1/2" lg x 1 1/4" wd x 1" h o/a, 0.065" thk material; mts by hole in formed end, and hole and elongated slot in formed wing; RH mtg, irregular shape elongated slot in body	Guide for and mounts 0-1662	N17-T-350014-269	CTT	150774	150774	0-1663	1	-	-	-	-
0-1664	LINK; steel: irregular shape w/two body ears and two differently formed ears; approx 2 1/4" lg x 3/4" h x 1/2" wd o/a, mts by two tapped holes and ID of hub welded to link; spring post riveted to body ear of link, link riveted to plate through bushing in link, RH mtg	Operates 0-1680	N17-T-350013-599	CTT	150727	150727	0-1664	1	-	-	-	-
0-1666	WASHER: felt; hard, white felt; round, approx 5/8" OD x 5/16" ID x 1/32" thk o/a	Lubricates 0-1667	N17-T-350014-335	CTT	150926	150926	0-1666, 0-1678	4	-	-	-	-
0-1667	Same as 0-1630	Roller guide for W-1303										
0-1668	BUSHING: steel, nickel plated; male and female; approx 3/8" OD x #6-40 tapped ID x 1 1/32" lg o/a, drive slot across head	Pivot for 0-1669	N17-T-350013-915	CTT	150255	150255	0-1668, 0-1676	2	-	-	-	-
0-1669	ARM: steel, nickel plated; irregular shape w/one arm; approx 3 1/2" lg x 2" h x 1/2" wd o/a, 0.072" thk material; mts by ID of bushing welded to end, RH mtg; stud welded to one end	Mounts 0-1667 and guides 0-1680	N17-T-350014-237	CTT	150721	150721	0-1669	1	-	-	-	-
0-1670	WASHER, felt: hard, white felt; round, approx 1 1/16" OD x 17/32" ID x 1/8" thk o/a	Lubricates 0-1669	N17-T-350013-630	CTT	89096	89096	0-1670, 0-1674	2	-	-	-	-
0-1671	BUSHING: steel; male and female; approx 7/32" OD x 5/32" ID x 9/32" lg o/a	Pivot for 0-1667	N17-T-350013-922	CTT	150705	150705	0-1671, 0-1677	2	-	-	-	-
0-1672	SLIDE: steel, nickel plated; irregular "U" shape w/sides turned in at ends, cutout in bottom, plate welded to bottom and ear extending down from one side w/hub welded to ear; approx 1 1/4" lg x 5/8" h x 1/2" wd, o/a; mts by inside of "U"; hole through hub, two tapped holes diagonally on ea side of "V" notch across plate	Operates 0-1844	N17-T-350014-293	CTT	150822	150822	0-1672	1	-	-	-	-
0-1673	WICK: lubrication wick; hard, white felt; approx 9/32" lg x 3/16" diam o/a	Lubricates 0-1672	N17-T-350002-671	CTT	85816	85816	0-1673	1	-	-	-	-
0-1674	Same as 0-1670	Lubricates 0-1675										
0-1675	ARM: steel, nickel plated; irregular shape w/one arm; approx 3 1/2" lg x 2" h x 1/2" wd o/a, 0.072" thk material; mts by ID of bushing welded to end, LH mtg; stud welded to one end	Mounts 0-1679 and guides 0-1680	N17-T-350014-236	CTT	150722	150722	0-1675	1	-	-	-	-
0-1676	Same as 0-1668	Pivot for 0-1675										

PARTS LISTS

TT-47/UG, TT-48/UG, TT-69/UG, TT-70/UG

NAVSHIPS 91393

Section 8  
O-1663-O-1676

TABLE 8-4. COMBINED PARTS AND SPARE PARTS LIST

SYMBOL DESIG.	NAME OF PART AND DESCRIPTION	FUNCTION	JAN OR NAVY TYPE DESIGNATION	STANDARD NAVY STOCK NUMBER	MANUFACTURERS		TELETYPE PART NO.	ALL SYMBOL DESIGNATIONS INVOLVED	SPARE PARTS										
					CODE	DESIG.			TOTAL NO. PER EQUIP.	EQUIP.		STOCK							
										BOX	QUAN.	BOX	QUAN.						
0-1677	Same as 0-1671	Pivot for 0-1679																	
0-1678	Same as 0-1666	Lubricates 0-1679																	
0-1679	Same as 0-1630	Roller guide for W-1303																	
0-1680	RAIL: steel, nickel plated; irregular "U" shape w/two wings on ea end and two wings near ctr with cutout on both ctr wings; approx 11 1/8" lg x 3/4" h x 3/8" wd o/a; mts by hole in ea end wing; bracket welded on ea end of body, elongated slot and hole in ea ctr wing	Guide for and positions 0-1672		N17-T-350013-600	CTT	150728	150728	0-1680	1	-	-	-	-	-	-	-	-	-	-
0-1681	RATCHET: steel, nickel plated; 18 teeth on circum, hub w/slotted out strip on side welded in ctr; approx 2 3/8" diam x 3/4" wd o/a; mts by ID of hub; six equidistant holes in ratchet	Adjusts tension of 0-1683		N17-T-350013-968	CTT	150251	150251	0-1681	1	-	-	-	-	-	-	-	-	-	-
0-1682	DISK: steel, nickel plated; circular shape w/three equidistant cutouts; approx 3 1/2" OD x 3/4" ID x 0.035" thk o/a; mts by ID; three elongated curved slots between cutouts, three small and six large pear shaped holes	Retains 0-1683 to 0-1687		N17-T-350014-279	CTT	150796	150796	0-1682	1	-	-	-	-	-	-	-	-	-	-
0-1683	SPRING: motor type; blue tempered clock spring steel 3/8" wd x 1/64" thk; approx 3/8" thk by 12" diam o/a; mts by slot on inside end	Applies tension to 0-1687		N17-T-350008-103	CTT	74272	74272	0-1683	1	1	1	-	-	-	-	-	-	-	-
0-1684	BUSHING: steel, nickel plated; male and female; approx 15/32" OD x 1/8" ID x 1/8" thk o/a, 3/8" diam x 1/32" thk shoulder, slot around center	Guide for W-1303		N17-T-350013-748	CTT	151619	151619	0-1684	1	-	-	-	-	-	-	-	-	-	-
0-1685	PLATE: steel, nickel plated; irregularly formed arm extending from one side; approx 3/4" lg x 3/8" h x 1/4" wd o/a, 0.065" thk material; mts by two tapped holes	Holds one end of 0-1683		N17-T-350013-927	CTT	150843	150843	0-1685	1	-	-	-	-	-	-	-	-	-	-
0-1686	WASHER, felt: hard, white felt; round, approx 5/8" OD x 3/8" ID x 1/4" thk o/a	Lubricates 0-1687		N17-T-350001-890	CTT	74755	74755	0-1686, 0-1695	2	1	2	-	-	-	-	-	-	-	-
0-1687	DRUM: spring; aluminum alloy, plain anodize; approx 3 1/2" OD x 1/4" ID x 11/16" wd o/a; mts by ID of bushing pressed in ID of drum; three slots around circum, six equidistant spokes, dished out on both sides, seven tapped holes in side, one tapped hole ctb two different diams and two body holes in OD	Guides and operates W-1303 and W-1304		N17-T-350014-297	CTT	150827	150827	0-1687	1	-	-	-	-	-	-	-	-	-	-

CHANGE 1

8-151

0-1688	ARM: steel, nickel plated; irregular circular shape w/arm w/wd formed curved end; approx 1 1/2" lg x 1 1/2" h x 3/8" wd o/a, 0.065 thk material; mts by circular cutout; two elongated curved slots around side of cutout	Operates 0-1585	N17-T-350013-889	CTT	150837	150837	0-1688	1	-	-	-	-	-
0-1689	ARM: steel, nickel plated; irregular shape w/two arms, one formed at end, other has stud riveted near end holding roller in place; approx 1 7/8" lg x 1 7/8" h x 1/2" wd o/a, 0.065" thk material; mts by large hole in body; two elongated curved slots around side of mtg hole	Operates 0-1593	N17-T-350014-300	CTT	150839	150839	0-1689	1	-	-	-	-	-
0-1690	RING: retainer; aluminum alloy, plain anodize; approx 3 1/2" OD x 3" ID x 1/4" thk o/a; mts by body holes in two formed ears on ID; ID has two cutouts, slot around circum	Guides and operates W-1303 and W-1304	N17-T-350014-299	CTT	150838	150838	0-1690	1	-	-	-	-	-
0-1691	RATCHET: steel, nickel plated; approx 3 1/2" OD x 3" ID x 3/16" wd o/a; mts by ID, 10 teeth around circum and notch in ID side of ratchet	Operates 0-1690 and 0-1693	N17-T-350014-842	CTT	150798	150798	0-1691	1	-	-	-	-	-
0-1692	SPACER: steel, nickel plated; approx 3/8" OD x 3/16" ID x 13/32" lg o/a; mts by ID	Spaces 0-1693 and 0-1625	N17-T-350014-145	CTT	150206	150206	0-1692	1	-	-	-	-	-
0-1693	DRUM, spacing: aluminum alloy, plain anodize; circular shape with 3 spokes to hub, has rise and slot both elongated also 3 tapped holes, 4 tapped holes at circum end of shaft, pin inserted in circum and bushing pressed in ID of drum; approx 3 1/2" OD x 5/8" wd o/a; mts by ID of bushing; slot around outside circum	Mounts W-1303, W-1304, 0-1688 to 0-1690, 0-1691, and 0-1694	N17-T-350014-295	CTT	150825	150825	0-1693	1	-	-	-	-	-
0-1694	LEVER: steel, nickel plated; "C" shaped one end, other end formed; approx 1 1/2" lg x 3/4" h x 3/8" wd o/a 0.065" thk material; mts by tapped hole near "C" shaped end	Operates 0-2026	N17-T-350014-135	CTT	150185	150185	0-1694	1	-	-	-	-	-
0-1695	Same as 0-1686	Lubricates 0-1693											
0-1696	SHAFT: steel; c/o head, slot, body w/wd groove and cutout on two sides at end, and shank; approx 1 13/16" lg x 1/4" diam o/a; mts by threaded shank	Operates 0-1700 and mounts type box clutch trip mechanism	N17-T-350014-630	CTT	150348	150348	0-1696	1	-	-	-	-	-
0-1697	Same as 0-255	Lubricates 0-1699											
0-1698	Same as 0-1380	Applies tension to 0-1699											
0-1699	LEVER: steel, nickel plated; "U" shaped one end w/formed spring notched ear on base, other end curved and formed; approx 1 19/32" lg x 3/8" h x 13/16" wd o/a, 0.051" thk material; mts by two holes in line in sides of "U"	Latches code bar clutch in stop position through 0-1765	N17-T-350014-752	CTT	150355	150355	0-1699, 0-1713, 0-1716, 0-1730, 0-1738	5	1	2	-	-	-

PARTS LISTS

TT-47/UG, TT-48/UG, TT-69/UG, TT-70/UG

NAVSHIPS 91393

0-1688—0-1699

Section 8



8-152

CHANGE 1

TABLE 8-4. COMBINED PARTS AND SPARE PARTS LIST

SYMBOL DESIG.	NAME OF PART AND DESCRIPTION	FUNCTION	JAN OR NAVY TYPE DESIGNATION	STANDARD NAVY STOCK NUMBER	MANUFAC- TURERS		TELETYPE PART NO.	ALL SYMBOL DESIGNATIONS INVOLVED	SPARE PARTS				
					CODE	DESIG.			TOTAL NO. PER EQUIP.	EQUIP.		STOCK	
										BOX	QUAN.	BOX	QUAN.
0-1700	LEVER: steel, nickel plated; "U" formed one end w/slot through bottom and sides to mtg holes, other end formed; approx 1 3/8" lg x 9/16" h x 1/4" wd o/a, 0.050" thk material; mts by two holes in line in sides of "U"	Stops code bar clutch in stop position through 0-1762		N17-T-350014-634	CTT	150356	150356	0-1700, 0-1719	2	1	2	-	-
0-1701	WASHER, felt: hard, white felt; round, approx 1/2" OD x 9/32" ID x 1/8" thk o/a	Lubricates 0-1700 and 0-1696		N17-T-350013-625	CTT	90819	90819	0-1701	2	1	2	-	-
0-1702	BUSHING: steel, nickel plated; male and female; approx 7/8" lg x 1/2" across flats x 1/4" ID o/a c/o head, hex shoulder, 3/8" - 32 threaded body and shank	Mounts 0-1696		N17-T-350013-917	CTT	150352	150352	0-1702	1	-	-	-	-
0-1703	LEVER: steel, nickel plated; irregular shape, formed ear notched on ea side w/hooded end, "V" notch near narrow end of body; approx 2 3/4" lg x 3/4" wd x 7/16" h o/a, 0.050" thk material; mts by elongated slot in large end	Operates 0-1696		N17-T-350014-686	CTT	150444	150444	0-1703	1	-	-	-	-
0-1704	SPRING: helical extension type; 0.014" diam music wire; approx 1 1/8" lg x 5/32" diam o/a; approx 58 turns; parallel hook terminals mts by terminals	Applies tension to 0-1703		N17-T-350013-909	CTT	125250	125250	0-1704	1	1	1	-	-
0-1705	Same as 0-288	Lubricates 0-1703											
0-1706	SHAFT: steel; c/o head, slot, body w/cutout on two sides at end and threaded shank; approx 9 3/4" lg x 1/4" diam o/a; mts by threaded shank	Operates 0-1719 and 0-1737 and mounts function clutch trip mechanism		N17-T-350014-631	CTT	150350	150350	0-1706	1	-	-	-	-
0-1707	Same as 0-1380	Applies tension to 0-1713											
0-1708	COLLAR: steel, nickel plated; approx 1/4" lg x 7/16" OD x 1/4" ID o/a; mts by ID; tapped hole near ea end	Retains 0-1713, 0-1712, 0-1716, 0-1719, and 0-1720 in position		N17-T-350001-800	CTT	74547	74547	0-1708, 0-1723, 0-1732	3	1	1	-	-
0-1709	Same as 0-255	Lubricates 0-1713											
0-1710	Same as 0-255	Lubricates 0-1711 and 0-1712											
0-1711	ARM: steel, nickel plated, "U" shaped one end, other end formed, arm on side formed at end, ear on base of "U"; approx 2 5/16" lg x 1" h x 1" wd o/a, 0.050" thk material; mts by two holes in line in sides of "U"	Operates 0-1712		N17-T-350014-637	CTT	150360	150360	0-1711	1	-	-	-	-
0-1712	LEVER: steel, nickel plated; one end formed, other end "U" formed w/body ear and formed ear w/notches on opposite sides of base; approx 1 3/8" lg x 7/8" h x 5/8" wd o/a; mts by two holes in line in sides of "U"; tapped hole in body ear of "U"	Stops spacing clutch in stop position through 0-1799		N17-T-350014-318	CTT	150889	150889	0-1712	1	1	1	-	-

8 Section  
O-1700-0-1712

TT-47/UG, TT-48/UG, TT-69/UG, TT-70/UG

NAVSHIPS 91393

PARTS LISTS

## PARTS LISTS

TT-47/UG, TT-48/UG, TT-69/UG, TT-70/UG

NAVSHIPS 91393

Section 8  
O-1713—O-1733

0-1713	Same as 0-1699	Latches spacing clutch in stop position through 0-1801																		
0-1714	Same as 0-1380	Applies tension to 0-1712																		
0-1715	Same as 0-255	Lubricates 0-1716																		
0-1716	Same as 0-1699	Latches function clutch in stop position through 0-1782																		
0-1717	SPACER: aluminum, plain anodized; approx 3/8" OD x 1/4" ID x 1/4" lg o/a; mts by ID	Spaces 0-1712 and 0-1716	N17-T-350014-638	CTT	150361	150361	0-1717	1	-	-	-	-	-	-	-	-	-	-	-	-
0-1718	Same as 0-1380	Applies tension to 0-1716																		
0-1719	Same as 0-1700	Stops function clutch in stop position through 0-1780																		
0-1720	FOLLOWER, cam: steel, nickel plated; irregular shape, bent and notched near center; tapped hole wide end and csk hole near notch; approx 1 5/8" lg x 3/16" h x 1/2" wd o/a, 0.065" thk material; mts by slot in smaller end; notch in extension arm, body bent at the center	Operates 0-1706	N17-T-350014-531	CTT	150349	150349	0-1720	1	-	-	-	-	-	-	-	-	-	-	-	-
0-1721	Same as 0-1363	Lubricates 0-1744																		
0-1723	Same as 0-1708	Retains 0-1724 and 0-1730 in position																		
0-1724	LEVER: steel, nickel plated; irregular shape w/"U" formed end w/spring notched formed ear one side of base and rounded ear other side, formed ear on body at curve; approx 2 5/32" lg x 1 5/32" h x 21/32" wd o/a, 0.051" thk material; mts by two holes in line in side of "U"; tapped hole in rounded ear on base of "U"	Stops line feed clutch in stop position through 0-1822	N17-T-350014-677	CTT	150431	150431	0-1724	1	1	1	-	-	-	-	-	-	-	-	-	-
0-1725	ARM: steel, nickel plated; irregular shaped and formed w/one end "U" formed w/ear extending from base of "U"; approx 2 1/8" lg x 3/4" h x 1/2" wd o/a, 0.050" thk material; mts by two holes in line in sides of "U"	Operates 0-1724.	N17-T-350014-560	CTT	150895	150895	0-1725	1	-	-	-	-	-	-	-	-	-	-	-	-
0-1726	Same as 0-1380	Applies tension to 0-1724																		
0-1728	Same as 0-255	Lubricates 0-1724 and 0-1725																		
0-1729	Same as 0-255	Lubricates 0-1730																		
0-1730	Same as 0-1699	Latches line feed clutch in stop position through 0-1825																		
0-1731	Same as 0-1380	Applies tension to 0-1730																		
0-1732	Same as 0-1708	Retains 0-1724 and 0-1730 in position																		
0-1733	Same as 0-255	Lubricates 0-1706																		

CHANGE 1

8-153

TABLE 8-4. COMBINED PARTS AND SPARE PARTS LIST

SYMBOL DESIG.	NAME OF PART AND DESCRIPTION	FUNCTION	JAN OR NAVY TYPE DESIGNATION	STANDARD NAVY STOCK NUMBER	MANUFACTURERS		TELETYPE PART NO.	ALL SYMBOL DESIGNATIONS INVOLVED	TOTAL NO. PER EQUIP.	SPARE PARTS				
					CODE	DESIG.				EQUIP.		STOCK		
										BOX	QUAN.	BOX	QUAN.	
0-1734	BUSHING: steel, nickel plated; male; approx 1 1/32" lg x 1/2" across flats o/a c/o hex head and body, threaded w/3/8" - 32 thd	Mounts 0-1706		N17-T-350014-670	CTT	150414	150414	0-1734, 0-1954, 0-1955	3	-	-	-	-	
0-1735	LEVER: steel, nickel plated; irregular shape, "U" formed one end w/formed spring notched ear on base, formed ear near other end; approx 1 11/16" lg x 15/16" h x 3/8" wd o/a, 0.051" thk material; mts by two holes in line in sides of "U"	Stops type box clutch in stop position through 0-1835		N17-T-350014-636	CTT	150358	150358	0-1735	1	1	1	-	-	
0-1736	Same as 0-1380	Applies tension to 0-1735												
0-1737	ARM: steel, nickel plated; "U" shape w/irregular shaped ear across top of one side, slot through bottom and sides to mtg holes, approx 3/4" lg x 1/2" h x 1/4" wd o/a, 0.050" thk material; mts by two holes in line in sides of "U"	Operates 0-1735		N17-T-350014-633	CTT	150354	150354	0-1737	1	-	-	-	-	
0-1738	Same as 0-1699	Latches type box clutch in stop position through 0-1839												
0-1739	Same as 0-1380	Applies tension to 0-1738												
0-1740	Same as 0-255	Lubricates 0-1738												
0-1741	Same as 0-1326	Lubricates 0-1742 and 0-1743												
0-1742	Same as 0-1379	Roller for 0-1743												
0-1743	DETENT, cam roller: steel approx 7/32" thk x 1/2" OD x 3/16" ID o/a; mts by ID, ctb ID to 5/16" diam x 3/32" deep	Cam roller guide for 0-1720		N17-T-350001-195	CTT	74785	74785	0-1743	1	-	-	-	-	
0-1744	SPRING: helical extension; 0.020" diam music wire; 1 3/32" lg x 3/16" OD o/a; 36 turns; hook end terms; mts by hook ends	Applies tension to 0-1743		N17-T-350009-218	CTT	82861	82861	0-1744	1	1	1	-	-	
0-1745	DRUM, clutch: steel, nickel plated; dished out one side w/88 teeth around inner circum, hub on other side w/slot through length to body hole, ea side, in face of drum, body hole through hub diam, ctb both sides; approx 1 5/8" OD x 5/16" ID x 1/2" lg o/a; mts by ID	Operates selector clutch through 0-1746 and 0-1747 when in engaged position		N17-T-350013-810	CTT	150001	150001	0-1745	1	1	1	-	-	
0-1746	Same as 0-269	Operates 0-1754												
0-1747	Same as 0-267	Operates 0-1754												
0-1748	Same as 0-265	Lubricates selector clutch												

8-154

CHANGE 1

CHANGE 1

0-1749	LEVER: steel, nickel plated; irregular shape, one end "U" formed, two ears formed to "U" shape other end; approx 1 11/16" lg x 13/16" wd x 3/16" h o/a, 0.042 thk material; mts by "U" formed ears; csk body hole in rise on lever	Engages and disengages O-1746 and O-1747 from O-1745	N17-T-350014-783	CTT	151640	151640	0-1749	1	1	1	-	-
0-1750	Same as 0-268	applies tension to O-1746 and O-1747										
0-1751	Same as 0-264	Adjusts gap between formed ear of O-1749 and O-1753										
0-1752	Same as 0-263	Applies tension to O-1749										
0-1753	Same as 0-262	Latch for H-1521 and mounts O-1751										
0-1754	CAM ASSEMBLY, selector: c/o head, shield w/two cutouts on circum, shank w/10 cams, 8 washers and two spacers, irregularly placed, located by pin and locked in place by nut, nut locked on by pin; approx 1 7/8" lg x 1" OD x 5/16" ID o/a; mts by ID of bearings pressed in at ea end	Operates O-1703, O-1751, O-1753 and O-1505 through O-1509	N17-T-350014-220	CTT	150527	150527	0-1754	1	-	-	-	-
0-1755	SHAFT: steel; approx 1 3/8" lg x 3/8" diam o/a; mts by shank on ea end; 5 slots and 10 holes throughout length	Mounts all parts of main shaft mechanism	N17-T-350014-555	CTT	150784	150784	0-1755	1	-	-	-	-
0-1756	BEARING, BALL: single row radial; 2 shields; light duty; approx 7/8" OD x 3/8" ID x 9/32" lg o/a; 7 balls; packed w/beacon 325 grease; std fit; A.B.E.C.- 1 std tol	Right side frame bearing for O-1755	N77-B-115-00619-2004	CGM	77-R-6	151633	0-1756, 0-2014	2	-	-	-	-
0-1757	PLATE, retainer: steel, nickel plated; irregular shaped cutout, sides formed by cut-out curved in and irregularly formed; approx 1 1/2" lg x 1" h x 1/8" wd o/a, 0.050" thk material; mts by two body holes	Retains O-1756 to right side frame	N17-T-350014-327	CTT	150908	150908	0-1757	1	-	-	-	-
0-1758	DRUM, clutch: steel, nickel plated; dished out one side w/88 teeth around inner circum, hub on other side w/slot through length to body hole, ea side, in face of drum, body hole ctb one end and tapped other end through hub diam; approx 1 5/8" OD x 7/16" ID x 1/2" lg o/a; mts by ID	Operates code bar clutch through O-1760 and O-1761 when in engaged position	N17-T-350004-784	CTT	150000	150000	0-1758, 0-1773, 0-1793, 0-1813, 0-1830	5	1	1	-	-
0-1759	Same as 0-268	Applies tension to O-1760 and O-1761										
0-1760	Same as 0-267	Operates O-1766										
0-1761	Same as 0-269	Operates O-1766										
0-1762	Same as 0-266	Engages and disengages O-1760 and O-1761 from O-1758										
0-1763	Same as 0-265	Lubricates code bar clutch										
0-1764	Same as 0-264	Adjusts gap between formed ear of O-1762 and O-1765										

8-155

PARTS LISTS

TT-47/UG, TT-48/UG, TT-69/UG, TT-70/UG

NAVSHIPS 91393

Section 8  
O-1749-O-1764

8-156

CHANGE 1

TABLE 8.4. COMBINED PARTS AND SPARE PARTS LIST

PARTS										SPARE PARTS				
SYMBOL DESIG.	NAME OF PART AND DESCRIPTION	FUNCTION	JAN OR NAVY TYPE DESIGNATION	STANDARD NAVY STOCK NUMBER	MANUFACTURERS		TELETYPE PART NO.	ALL SYMBOL DESIGNATIONS INVOLVED	TOTAL NO. PER EQUIP.	EQUIP.		STOCK		
					CODE	DESIG.				BOX	QUAN.	BOX	QUAN.	
0-1765	Same as 0-262	Latch for 0-1699 and mounts 0-1764, 0-1766, 0-1769, 0-1772 and associated parts												
0-1766	BEARING, sleeve: super oilite; approx 27/32" lg x 31/32" OD x 7/16" ID o/a, 2 grooves and 2 straight cutouts on one end, 1 groove on other end, 2 body holes	Operates 0-1765, 0-1764, 0-1762, 0-1768 and 0-1772		N17-T- 350013- 818	CTT	150047	150047	0-1766	1	1	1	-	-	
0-1767	SPACER, clutch: stainless steel; irregular curved shape; approx 1 5/16" OD x 17/32" ID x 0.028" thk o/a; mts by off-center ID w/2 elongated slots; circle scribed on one side; straight cutout on circum	Retains 0-1768 on 0-1769		N17-T- 350014- 131	CTT	150050	150050	0-1767	2	-	-	-	-	
0-1768	ARM: steel, nickel plated; both ends rounded, hub welded to small end; approx 3 1/8" lg x 1 7/16" wd x 5/32" h o/a, 0.065" thk mater- ial; mts by large body hole in large end	Operates 0-2115 through H-2154		N17-T- 350014- 253	CTT	150056	150056	0-1768	1	1	1	-	-	
0-1769	SPACER, clutch: super oilite; approx 13/16" OD x 9/16" ID x 0.064" thk o/a; mts by ID; circle scribed on one side; 2 elongated slots on ID	Operates 0-1768		N17-T- 350013- 820	CTT	150051	150051	0-1769	1	1	1	-	-	
0-1771	WASHER: steel, nickel plated; round, approx 1 1/16" OD x 9/16" ID x 1/16" thk o/a; two elongated ears on ID	Spaces 0-1767 and 0-1772		N17-T- 350013- 812	CTT	150016	150016	0-1771	1	-	-	-	-	
0-1772	GAM: steel, nickel plated; one half round, other half irregular shape w/two rises; approx 1 5/8" OD x 9/16" ID x 3/32" thk o/a; mts by ID w/two elongated cutouts; circle scribed near circum	Operates 0-1720 through 0-1743		N17-T- 350014- 832	CTT	150004	150004	0-1772	1	-	-	-	-	
0-1773	Same as 0-1758	Operates function clutch through 0-1774 and 0-1775 when in engaged position												
0-1774	Same as 0-267	Operates 0-1783												
0-1775	Same as 0-269	Operates 0-1783												
0-1776	Same as 0-268	Applies tension to 0-1774 and 0-1775												
0-1777	SPRING: helical extension type; 0.016" diam music wire; approx 9/16" lg x 1/8" OD o/a; approx 22 turns; hook terms, indexed 90°; mts by terms	Applies tension to 0-1780		N17-T- 350014- 927	CTT	151736	151736	0-1777, 0-1798, 0-1821	6	-	3	-	-	

8 Section  
0-1765-0-1777TT-47/UG, TT-48/UG, TT-69/UG, TT-70/UG  
NAVSHIPS 91393

PARTS LISTS

0-1778	LEVER: steel, nickel plated; irregular "C" shape; approx 1 7/16" lg x 1" h x 9/32" wd o/a, 0.042" thk material; mts by "U" formed end; formed ear near one end	Engages and disengages O-1774, and O-1775 from O-1773	N17-T-350014-747	CTT	150027	150027	0-1778, 0-1797, 0-1819	3	1	1	-	-
0-1779	Same as O-265	Lubricates function clutch										
0-1780	DISK: steel, nickel plated; approx 1 13/16" lg x 15/16" h x 3/16" wd o/a, 0.035" thk material; mts by body hole in ctr; two arms formed at ends w/curved ear on ea, rectangular shaped cutout in irregular shaped arm	Operates O-1778	N17-T-350014-611	CTT	150034	150034	0-1780	1	1	1	-	-
0-1781	DISK: steel, nickel plated; irregular circular shape; approx 1 3/8" lg x 1 1/16" wd x 5/16" h o/a, 0.065" thk material; mts by two tapped holes in rounded ears on circum; three cutouts and formed ear in irregular shaped ID, squared ear on circum	Adjusts gap between formed ears of O-1780 and O-1782	N17-T-350014-606	CTT	150014	150014	0-1781, 0-1800, 0-1824	3	1	1	-	-
0-1782	DISK: steel, nickel plated; irregular circular shape; approx 1 7/8" lg x 1 11/16" h x 5/8" wd o/a, 0.065" thk material; mts by round ended slot in approx ctr; four cutouts and two formed ears along edge; five irregular shaped body holes, two elongated slots and two tapped holes in disk, two spring posts and one stud riveted to disk	Latch for O-1716 and mounts O-1781, O-1783 through O-1792 and H-1836	N17-T-350014-609	CTT	150032	150032	0-1782	1	1	1	-	-
0-1783	BEARING, sleeve: super oilite; approx 7/8" lg x 7/16" ID x 7/8" OD o/a, 2 straight cutouts, second flange cutout on one side only, 3 grooves around shank	Operates O-1780, O-1782 and O-1791	N17-T-350013-816	CTT	150045	150045	0-1783, 0-1802	2	1	1	-	-
0-1784	KEY: steel, nickel plated; circular shaped with large elongated cutout in one side, two other small cutouts on circum; approx 3/4" OD x 0.031" thk o/a; mts on shaft by large elongated cutout	Retains O-1782 on O-1783	N17-T-350014-298	CTT	150832	150832	0-1784, 0-1803, 0-1826	3	-	-	-	-
0-1785	BEARING, sleeve: stainless steel; approx 1/8" lg x 3/4" OD x 5/8" ID o/a, shoulder 1/16" lg x 11/16" diam, slot across face	Bearing for O-1780 and O-1781	N17-T-350014-369	CTT	150841	150841	0-1785, 0-1804	2	-	-	-	-
0-1786	RING, retainer: steel, nickel plated; ID dished out by three different diams; approx 1" OD x 1/2" ID x 1/8" wd o/a; mts by ID; two small body holes	Spaces O-1782 and H-1836	N17-T-350014-559	CTT	150831	150831	0-1786, 0-1805, 0-1827	3	-	-	-	-
0-1787	BUSHING: stainless steel; male and female 7/8" OD x 5/8" ID x 3/32" thk	Guide for O-1778	N17-T-350014-558	CTT	150830	150830	0-1787, 0-1806, 0-1820	3	-	-	-	-
0-1788	SPACER, clutch: stainless steel; approx 1 1/4" OD x 9/16" ID x 0.028" thk o/a; mts by off-center ID w/2 elongated cutouts; circle scribed on one side; small body hole near circum	Retains O-1789 on O-1791	N17-T-350013-819	CTT	150049	150049	0-1788	2	-	-	-	-
0-1789	ARM: steel, nickel plated; both ends rounded w/tapered body; approx 2 1/4" lg x 1 7/8" h o/a, 0.065" thk material; mts by hole in large end; bushing welded to small end	Operates O-1790	N17-T-350014-615	CTT	150057	150057	0-1789	1	1	1	-	-

CHANGE 1

8-157

8-158

CHANGE 1

TABLE 8-4. COMBINED PARTS AND SPARE PARTS LIST

SYMBOL DESIG.	NAME OF PART AND DESCRIPTION	FUNCTION	JAN OR NAVY TYPE DESIGNATION	STANDARD NAVY STOCK NUMBER	MANUFAC- TURERS		TELETYPE PART NO.	ALL SYMBOL DESIGNATIONS INVOLVED	TOTAL NO. PER EQUIP.	SPARE PARTS			
					CODE	DESIG.				EQUIP.		STOCK	
										BOX	QUAN.	BOX	QUAN.
0-1790	ARM: steel, nickel plated; irregularly shaped, one end rounded, ear other end, two body holes and elongated slot; approx 4" lg x 5/16" wd x 5/32" h o/a; mts by body holes; bushing butt welded to one end	Operates 0-1942		N17-T-350014-598	CTT	151704	151704	0-1790	1	-	-	-	-
0-1791	SPACER, clutch: super oilite; approx 1 1/8" OD x 9/16" ID x 0.064" thk o/a; mts by off-center ID w/2 elongated cutouts; circle scribed on one side; small body hole near circum	Operates 0-1789		N17-T-350013-821	CTT	150052	150052	0-1791	1	1	1	-	-
0-1792	Same as 0-265	Lubricates spacing clutch											
0-1793	Same as 0-1758	Operates spacing clutch through 0-1794 and 0-1795 when in engaged position											
0-1794	Same as 0-267	Operates 0-1802											
0-1795	Same as 0-269	Operates 0-1802											
0-1796	Same as 0-268	Applies tension to 0-1794 and 0-1795											
0-1797	Same as 0-1778	Engages and disengages 0-1794 and 0-1795 from 0-1793											
0-1798	Same as 0-1777	Applies tension to 0-1799											
0-1799	DISK: steel, nickel plated; approx 1 3/4" lg x 1 5/8" h x 3/16" wd o/a, 0.035" thk material; mts by body hole in ctr; four arms, three formed at end, two w/curved ear and one w/cutout at end	Operates 0-1797		N17-T-350014-612	CTT	150035	150035	0-1799, 0-1822	2	1	1	-	-
0-1800	Same as 0-1781	Adjusts gap between formed ears of 0-1799 and 0-1801											
0-1801	DISK: steel, nickel plated; irregular circular shape; approx 1 13/16" largest diam x 5/16" wd o/a; 0.065" thk material; mts by round ended slot in approx ctr; six cutouts and three formed ears on circum, five irregular shaped body holes, two elongated slots and two tapped holes in disk, two spring posts riveted to disk	Latch for 0-1713 and mounts 0-1800 and 0-1803 through 0-1808		N17-T-350014-610	CTT	150033	150033	0-1801, 0-1825	2	1	1	-	-
0-1802	Same as 0-1783	Operates 0-1799, 0-1801, 0-1807, and 0-1808											
0-1803	Same as 0-1784	Retains 0-1801 on 0-1802											

8 Section  
O-1790-0-1803

TT-47/UG, TT-48/UG, TT-69/UG, TT-70/UG

NAVSHIPS 91393

PARTS LISTS

0-1804	Same as 0-1785	Bearing for 1799 and 0-1800																		
0-1805	Same as 0-1786	Spaces 0-1801 and 0-1807																		
0-1806	Same as 0-1787	Guide for 0-1797																		
0-1807	CAM: black bakelite; three equidistant rises; approx 1 7/16" OD x 9/16" ID x 1/8" thk o/a; mts by ID; circle scribed on one side below a rise; two elongated notches in ID	Unlatches 0-2036	N17-T-350013-811	CTT	150003	150003	0-1807	1	-	-	-	-	-	-	-	-	-	-	-	-
0-1808	GEAR: spur; natural color bakelite; helical teeth; RH; 27 teeth; 22 pitch, 1.98" PD; approx 2 3/32" OD x 3/16" thk; straight face; mts by bore w/2 elongated slots	Operates 0-1613	N17-T-350014-115	CTT	150091	150091	0-1808	1	-	-	-	-	-	-	-	-	-	-	-	-
0-1809	COLLAR; steel, nickel plated; short shank ea end; approx 5/8" OD x 7/16" ID x 11/32" lg; mts by ID; flat cutout on one side w/hole	Locks 0-1808 in position	N17-T-350014-207	CTT	150549	150549	0-1809	1	-	-	-	-	-	-	-	-	-	-	-	-
0-1810	GEAR: spur; natural color bakelite; helical teeth; LH; 60 teeth; 26 pitch, 2.40" PD; approx 2 15/32" OD x 7/16" ID x 5/16" thk o/a; straight face; mts by ID and 3 body holes	Operates 0-1811	N17-T-350014-682	CTT	150439	150439	0-1810	1	-	-	-	-	-	-	-	-	-	-	-	-
0-1811	HUB: aluminum, plain anodize finish; approx 1 1/8" OD x 7/16" ID x 1/2" wd o/a; mts by 3 tapped holes; body hole in circum	Operates 0-1755 and 0-1812	N17-T-350014-683	CTT	150440	150440	0-1811	1	-	-	-	-	-	-	-	-	-	-	-	-
0-1812	GEAR: spur; natural color bakelite; helical teeth; LH; 21 teeth; 24 pitch, 1.57 PD; 1 21/32" OD x 1/2" thk o/a; straight face; mts by center hole and three body holes	Operates 0-270	N17-T-350014-684	CTT	150441	150441	0-1812	1	-	-	-	-	-	-	-	-	-	-	-	-
0-1813	Same as 0-1758	Operates line feed clutch through 0-1814 and 0-1815																		
0-1814	Same as 0-269	Operates 0-1817																		
0-1815	Same as 0-267	Operates 0-1817																		
0-1816	Same as 0-268	Applies tension to 0-1814 and 0-1815																		
0-1817	Same as 0-1527	Operates 0-1822, 0-1825 and 0-1828																		
0-1818	Same as 0-265	Lubricates line feed clutch																		
0-1819	Same as 0-1778	Engages and disengages 0-1814 and 0-1815 from 0-1815																		
0-1820	Same as 0-1787	Guide for 0-1819																		
0-1821	Same as 0-1777	Applies tension to 0-1822																		
0-1822	Same as 0-1799	Operates 0-1819																		
0-1823	Same as 0-1785	Bearing for 0-1822 and 0-1824																		
0-1824	Same as 0-1781	Adjusts gap between formed ears of 0-1799 and 0-1801																		

CHANGE 1

8-159



TABLE 8-4. COMBINED PARTS AND SPARE PARTS LIST

SYMBOL DESIG.	NAME OF PART AND DESCRIPTION	FUNCTION	JAN OR NAVY TYPE DESIGNATION	STANDARD NAVY STOCK NUMBER	MANUFACTURERS		TELETYPE PART NO.	ALL SYMBOL DESIGNATIONS INVOLVED	SPARE PARTS										
					CODE	DESIG.			TOTAL NO. PER EQUIP.	EQUIP.		STOCK							
										BOX	QUAN.	BOX	QUAN.						
0-1825	Same as 0-1801	Latch for 0-1730 and mounts 0-1824, 0-1826, 0-1827, 0-1828, and H-1837																	
0-1826	Same as 0-1784	Retains 0-1825 on 0-1817																	
0-1827	Same as 0-1786	Spaces 0-1825 and H-1837																	
0-1828	GEAR: spur; natural color bakelite; straight teeth; 42 teeth; 24 pitch, 1.75 PD; approx 1 27/32" OD x 9/16" ID x 3/16" thk o/a; straight face; center hole 9/16" diam with 2 elongated slots, one slot off center; mts by ID and slot	Operates 0-1994		N17-T- 350013- 933	CTT	150665	150665	0-1828	1	-	-	-	-	-	-	-	-	-	-
0-1829	BEARING, sleeve: steel, nickel plated; male bushing mtd in ID of bearing; approx 1 1/8" OD x 5/8" wd x 7/16" ID o/a; hole through shank, ctb one side, threaded other side, elongated slot through shank	Left side frame bearing for 0-1755		N17-T- 350014- 167	CTT	150970	150970	0-1829	1	-	-	-	-	-	-	-	-	-	-
0-1830	Same as 0-1758	Operates type box clutch through 0-1831 and 0-1832																	
0-1831	Same as 0-269	Operates 0-1840																	
Q-1832	Same as 0-267	Operates 0-1840																	
0-1833	Same as 0-255	Lubricates 0-1914 and 0-1920																	
0-1834	Same as 0-268	Applies tension to 0-1831 and 0-1832																	
0-1835	Same as 0-266	Engages and disengages 0-1831 and 0-1832 from 0-1830																	
0-1836	Same as 0-265	Lubricates type box clutch																	
0-1837	Same as 0-264	Adjusts gap formed by ear of 0-1835 and 0-1839																	
0-1838	Same as 0-263	Applies tension to 0-1835																	
0-1839	Same as 0-262	Latch for 0-1738 and mounts 0-1837 and 0-1840																	
0-1840	BEARING, sleeve: super oilite; approx 1" lg x 1" OD x 3/8" ID o/a, 2 grooves and 2 cut- outs on one end, partial groove on other end, offset mtg hole, 3 body holes, one tapped hole	Operates 0-1839 and 0-1842		N17-T- 350013- 817	CTT	150046	150046	0-1840	1	1	1	-	-	-	-	-	-	-	-

8-160

CHANGE 1

## PARTS LISTS

## NAVSHIPS 91393

TT-47/UG, TT-48/UG, TT-69/UG, TT-70/UG

Section 8  
O-1841-O-1852

0-1841	PLATE, retainer: steel, nickel plated; triangular shape w/rounded corners; approx 5/8" lg x 5/16" wd x 0.035" thk o/a; mts by single body hole	Retains 0-1842 and 0-1840	N17-T-350004-785	CTT	150010	150010	0-1841	1	1	1	-	-	-	-	-
0-1842	LINK: steel, nickel plated; irregular shape w/rounded ends; approx 2 3/8" lg x 13/16" h x 1/2" wd o/a, 0.065" thk material; mts by ID of hub welded to large end; stud butt welded through small end	Operates 0-2009	N17-T-350013-966	CTT	150244	150244	0-1842	1	1	1	-	-	-	-	-
0-1843	Same as 0-268	Applies tension to 0-1762													
0-1844	LINK: steel, chrome nickel; rounded both ends curved near one end, stud riveted on one end, pin butt welded to other end; approx 2 3/16" lg x 3/8" h x 11/16" wd o/a, 0.050" thk material; mts by slots in stud and pin	Operates 0-1848	N17-T-350014-753	CTT	150368	150368	0-1844	1	-	-	-	-	-	-	-
0-1845	LATCH: steel, nickel plated; "C" shaped latch w/ear one end and lever riveted by cutout to formed end; approx 1 1/4" lg x 3/4" w x 1/8" thk o/a; mts by hole in end w/ear	Latches type box mechanism	N17-T-350014-123	CTT	150075	150075	0-1845	1	-	-	-	-	-	-	-
0-1846	SHIM: steel; approx 3/16" OD x 1/8" ID x 0.002" thk o/a; mts by ID	Spaces 0-1847 and 0-1849	N17-T-350014-653	CTT	150381	150381	0-1846, 0-1910	12	1	3	-	-	-	-	-
0-1847	CONE, bearing: chrome vanadium steel; approx 1/4" OD x 1/8" ID x 1/8" wd o/a; mts by ID; OD tapered on one side	Retains 0-1850 in 0-1849	N17-T-350014-125	CTT	150072	150072	0-1847	2	1	1	-	-	-	-	-
0-1848	PLATE: aluminum, black anodize; irregular shape, two ears on one side w/arm riveted to one ear and loosely mtd to other ear by bushing press fitted, bushing staked near other bushing, cutout on other side; approx 3 5/16" lg x 1 7/8" h x 1/8" wd o/a, 0.064" thk material; mts by hole at ea end of cutout and ID of staked bushing; tapped ID in pressed bushing, five body holes irregularly located	Operates type box mechanism and mounts 0-1852	N17-T-350014-126	CTT	150071	150071	0-1848	1	-	-	-	-	-	-	-
0-1849	ROLLER: steel; approx 1/8" wd x 15/32" OD x 1/4" ID o/a; mts by ID; "V" shaped slot in ID, rectangular slot in OD	Roller for 0-1848	N17-T-350014-122	CTT	150076	150076	0-1849, 0-1912	3	1	1	-	-	-	-	-
0-1850	BALL, bearing: steel; spherical; approx 1/16" diam o/a	Bearing balls for 0-1849	N17-T-350005-401	CTT	3637	3637	0-1850, 0-1911	36	1	6	-	-	-	-	-
0-1851	CONE, bearing: chrome vanadium steel; approx 1/4" OD x 1/8" ID x 1/16" thk o/a; mts by ID; OD tapered on one side	Retains 0-1850 in 0-1849	N17-T-350014-124	CTT	150073	150073	0-1851, 0-1909, 0-1913	4	1	2	-	-	-	-	-
0-1852	GUIDE, ribbon: nickel silver; irregular shape w/folded arm ea end, two cutouts on bottom, cutout in ctr of body w/formed ear; approx 2 7/16" lg x 1 1/4" h x 3/8" wd o/a, 0.020" thk material; mts by hole near ea arm	Guide for ribbon from 0-1358	N17-T-350014-119	CTT	150083	150083	0-1852	1	-	-	-	-	-	-	-

CHANGE 1

8-161

TABLE 8-4. COMBINED PARTS AND SPARE PARTS LIST

SYMBOL DESIG.	NAME OF PART AND DESCRIPTION	FUNCTION	JAN OR NAVY TYPE DESIGNATION	STANDARD NAVY STOCK NUMBER	MANUFACTURERS		TELETYPE PART NO.	ALL SYMBOL DESIGNATIONS INVOLVED	SPARE PARTS				
					CODE	DESIG.			TOTAL NO. PER EQUIP.	EQUIP.		STOCK	
										BOX	QUAN.	BOX	QUAN.
0-1853	STUD: stainless steel; approx 13/32" lg x 1/4" across flats o/a; short shanked end threaded 3/16" deep w/#4-40 thd	Handle for removing and guide for positioning type box mechanism		N17-T-350013-910	CTT	150079	150079	0-1853	1	1	1	-	-
0-1854	PALLET, type: dummy pallet; steel, nickel plated; approx 7/16" lg x 3/16" h x 3/32" wd o/a; mts by shaft w/1/32" wd x 1/16" lg spring mtg hole	Protects empty spaces in O-1855 from O-1305		N17-T-350014-847	CTT	150973	150973	0-1854	13	-	-	-	-
0-1855	PLATE, rear: type box; steel, black oxidize; approx 3 1/8" lg x 1" h x 5/16" wd o/a; mts by elongated hole ea end; 64 oblong perforations on face	Guide for and mounts O-1858 through O-1908		N17-T-350014-117	CTT	150085	150085	0-1855	1	-	-	-	-
0-1856	SPRING: torsion type; 0.008" diam music wire; approx 3/8" lg x 5/32" h x 3/32" wd o/a; 9 turns; RH or LH spiral permissible; mts by straight term one end	Retracts O-1854, O-1858 through O-1907 or O-1908		N17-T-350014-913	CTT	150077	150077	0-1856	64	1	5	-	-
0-1857	PLATE, front: type box; steel, black oxidize; approx 3 1/8" lg x 1" h x 1/4" wd o/a; mts by elongated hole near ea end; 64 oblong perforations on face	Guide for and mounts O-1858 through O-1908		N17-T-350014-118	CTT	150084	150084	0-1857	1	-	-	-	-
0-1858	PALLET, type: character (A); steel, nickel plated; Murray style type; approx 5/8" lg x 3/32" wd x 3/16" h o/a; mts by shaft w/spring mtg hole near shoulder; curved type on 7/8" rad	Makes impression of character "A" on paper		N17-T-350013-822	CTT	150100	150100	0-1858	1	-	-	-	-
0-1859	PALLET, type: character (B); steel, nickel plated; Murray style type; approx 5/8" lg x 3/32" wd x 3/16" h o/a; mts by shaft w/spring mtg hole near shoulder; curved type on 7/8" rad	Makes impression of character "B" on paper		N17-T-350013-823	CTT	150101	150101	0-1859	1	-	-	-	-
0-1860	PALLET, type: character (C); steel, nickel plated; Murray style type; approx 5/8" lg x 3/32" wd x 3/16" h o/a; mts by shaft w/spring mtg hole near shoulder; curved type on 7/8" rad	Makes impression of character "C" on paper		N17-T-350013-824	CTT	150102	150102	0-1860	1	-	-	-	-
0-1861	PALLET, type: character (D); steel, nickel plated; Murray style type; approx 5/8" lg x 3/32" wd x 3/16" h o/a; mts by shaft w/spring mtg hole near shoulder; curved type on 7/8" rad	Makes impression of character "D" on paper		N17-T-350013-825	CTT	150103	150103	0-1861	1	-	-	-	-
0-1862	PALLET, type: character (E); steel, nickel plated; Murray style type; approx 5/8" lg x 3/32" wd x 3/16" h o/a; mts by shaft w/spring mtg hole near shoulder; curved type on 7/8" rad	Makes impression of character "E" on paper		N17-T-350013-858	CTT	150104	150104	0-1862	1	-	-	-	-

8-162

CHANGE 1

PARTS LISTS

NAVSHIPS 91393

TT-47/UG, TT-48/UG, TT-69/UG, TT-70/UG

Section 8  
O-1863—O-1872

0-1863	PALLET, type: character (F); steel, nickel plated; Murray style type; approx 5/8" lg x 3/32" wd x 3/16" h o/a; mts by shaft w/spring mtg hole near shoulder; curved type on 7/8" rad	Makes impression of character "F" on paper	N17-T-350013-859	CTT	150105	150105	0-1863	1	-	-	-	-
0-1864	PALLET, type: character (G); steel, nickel plated; Murray style type; approx 5/8" lg x 3/32" wd x 3/16" h o/a; mts by shaft w/spring mtg hole near shoulder; curved type on 7/8" rad	Makes impression of character "G" on paper	N17-T-350013-860	CTT	150106	150106	0-1864	1	-	-	-	-
0-1865	PALLET, type: character (H); steel, nickel plated; Murray style type; approx 5/8" lg x 3/32" wd x 3/16" h o/a; mts by shaft w/spring mtg hole near shoulder; curved type on 7/8" rad	Makes impression of character "H" on paper	N17-T-350013-861	CTT	150107	150107	0-1865	1	-	-	-	-
0-1866	PALLET, type: character (I); steel, nickel plated; Murray style type; approx 5/8" lg x 3/32" wd x 3/16" h o/a; mts by shaft w/spring mtg hole near shoulder; curved type on 7/8" rad	Makes impression of character "I" on paper	N17-T-350013-862	CTT	150108	150108	0-1866	1	-	-	-	-
0-1867	PALLET, type: character (J); steel, nickel plated; Murray style type; approx 5/8" lg x 3/32" wd x 3/16" h o/a; mts by shaft w/spring mtg hole near shoulder; curved type on 7/8" rad	Makes impression of character "J" on paper	N17-T-350013-863	CTT	150109	150109	0-1867	1	-	-	-	-
0-1868	PALLET, type: character (K); steel, nickel plated; Murray style type; approx 5/8" lg x 3/32" wd x 3/16" h o/a; mts by shaft w/spring mtg hole near shoulder; curved type on 7/8" rad	Makes impression of character "K" on paper	N17-T-350013-864	CTT	150110	150110	0-1868	1	-	-	-	-
0-1869	PALLET, type: character (L); steel, nickel plated; Murray style type; approx 5/8" lg x 3/32" wd x 3/16" h o/a; mts by shaft w/spring mtg hole near shoulder; curved type on 7/8" rad	Makes impression of character "L" on paper	N17-T-350013-865	CTT	150111	150111	0-1869	1	-	-	-	-
0-1870	PALLET, type: character (M); steel, nickel plated; Murray style type; approx 5/8" lg x 3/32" wd x 3/16" h o/a; mts by shaft w/spring mtg hole near shoulder; curved type on 7/8" rad	Makes impression of character "M" on paper	N17-T-350013-866	CTT	150112	150112	0-1870	1	-	-	-	-
0-1871	PALLET, type: character (N); steel, nickel plated; Murray style type; approx 5/8" lg x 3/32" wd x 3/16" h o/a; mts by shaft w/spring mtg hole near shoulder; curved type on 7/8" rad	Makes impression of character "N" on paper	N17-T-350013-867	CTT	150113	150113	0-1871	1	-	-	-	-
0-1872	PALLET, type: character (O); steel, nickel plated; Murray style type; approx 5/8" lg x 3/32" wd x 3/16" h o/a; mts by shaft w/spring mtg hole near shoulder; curved type on 7/8" rad	Makes impression of character "O" on paper	N17-T-350013-868	CTT	150114	150114	0-1872	1	-	-	-	-

CHANGE 1

8-163

8-164

CHANGE 1

TABLE 8-4. COMBINED PARTS AND SPARE PARTS LIST

SYMBOL DESIG.	NAME OF PART AND DESCRIPTION	FUNCTION	JAN OR NAVY TYPE DESIGNATION	STANDARD NAVY STOCK NUMBER	MANUFAC- TURERS		TELETYPE PART NO.	ALL SYMBOL DESIGNATIONS INVOLVED	TOTAL NO. PER EQUIP.	SPARE PARTS				
					CODE	DESIG.				EQUIP.		STOCK		
										BOX	QUAN.	BOX	QUAN.	
0-1873	PALLET, type: character (P); steel, nickel plated; Murray style type; approx 5/8" lg x 3/32" wd x 3/16" h o/a; mts by shaft w/spring mtg hole near shoulder; curved type on 7/8" rad	Makes impression of character "P" on paper		N17-T-350013-869	CTT	150115	150115	0-1873	1	-	-	-	-	
0-1874	PALLET, type: character (Q); steel, nickel plated; Murray style type; approx 5/8" lg x 3/32" wd x 3/16" h o/a; mts by shaft w/spring mtg hole near shoulder; curved type on 7/8" rad	Makes impression of character "Q" on paper		N17-T-350013-870	CTT	150116	150116	0-1874	1	-	-	-	-	
0-1875	PALLET, type: character (R); steel, nickel plated; Murray style type; approx 5/8" lg x 3/32" wd x 3/16" h o/a; mts by shaft w/spring mtg hole near shoulder; curved type on 7/8" rad	Makes impression of character "R" on paper		N17-T-350013-871	CTT	150117	150117	0-1875	1	-	-	-	-	
0-1876	PALLET, type: character (S); steel, nickel plated; Murray style type; approx 5/8" lg x 3/32" wd x 3/16" h o/a; mts by shaft w/spring mtg hole near shoulder; curved type on 7/8" rad	Makes impression of character "S" on paper		N17-T-350013-872	CTT	150118	150118	0-1876	1	-	-	-	-	
0-1877	PALLET, type: character (T); steel, nickel plated; Murray style type; approx 5/8" lg x 3/32" wd x 3/16" h o/a; mts by shaft w/spring mtg hole near shoulder; curved type on 7/8" rad	Makes impression of character "T" on paper		N17-T-350013-873	CTT	150119	150119	0-1877	1	-	-	-	-	
0-1878	PALLET, type: character (U); steel, nickel plated; Murray style type; approx 5/8" lg x 3/32" wd x 3/16" h o/a; mts by shaft w/spring mtg hole near shoulder; curved type on 7/8" rad	Makes impression of character "U" on paper		N17-T-350013-826	CTT	150120	150120	0-1878	1	-	-	-	-	
0-1879	PALLET, type: character (V); steel, nickel plated; Murray style type; approx 5/8" lg x 3/32" wd x 3/16" h o/a; mts by shaft w/spring mtg hole near shoulder; curved type on 7/8" rad	Makes impression of character "V" on paper		N17-T-350013-827	CTT	150121	150121	0-1879	1	-	-	-	-	
0-1880	PALLET, type: character (W); steel, nickel plated; Murray style type; approx 5/8" lg x 3/32" wd x 3/16" h o/a; mts by shaft w/spring mtg hole near shoulder; curved type on 7/8" rad	Makes impression of character "W" on paper		N17-T-350013-828	CTT	150122	150122	0-1880	1	-	-	-	-	
0-1881	PALLET, type: character (X); steel, nickel plated; Murray style type; approx 5/8" lg x 3/32" wd x 3/16" h o/a; mts by shaft w/spring mtg hole near shoulder; curved type on 7/8" rad	Makes impression of character "X" on paper		N17-T-350013-829	CTT	150123	150123	0-1881	1	-	-	-	-	

8 Section  
O-1873—O-1881

TT-47/UG, TT-48/UG, TT-69/UG, TT-70/UG

NAVSHIPS 91393

PARTS LISTS

## PARTS LISTS

## NAVSHIPS 91393

TT-47/UG, TT-48/UG, TT-69/UG, TT-70/UG

Section 8  
O-1882—O-1891

0-1882	PALLET, type; character (Y); steel, nickel plated; Murray style type; approx 5/8" lg x 3/32" wd x 3/16" h o/a; mts by shaft w/spring mtg hole near shoulder; curved type on 7/8" rad	Makes impression of character "Y" on paper	N17-T-350013-830	CTT	150124	150124	0-1882	1	-	-	-	-	-
0-1883	PALLET, type; character (Z); steel, nickel plated; Murray style type; approx 5/8" lg x 3/32" wd x 3/16" h o/a; mts by shaft w/spring mtg hole near shoulder; curved type on 7/8" rad	Makes impression of character "Z" on paper	N17-T-350013-831	CTT	150125	150125	0-1883	1	-	-	-	-	-
0-1884	PALLET, type; character (1); steel, nickel plated; Murray style type; approx 5/8" lg x 3/32" wd x 3/16" h o/a; mts by shaft w/spring mtg hole near shoulder; curved type on 7/8" rad	Makes impression of character "1" on paper	N17-T-350013-832	CTT	150126	150126	0-1884	1	-	-	-	-	-
0-1885	PALLET, type; character (2); steel, nickel plated; Murray style type; approx 5/8" lg x 3/32" wd x 3/16" h o/a; mts by shaft w/spring mtg hole near shoulder; curved type on 7/8" rad	Makes impression of character "2" on paper	N17-T-350013-833	CTT	150127	150127	0-1885	1	-	-	-	-	-
0-1886	PALLET, type; character (3); steel, nickel plated; Murray style type; approx 5/8" lg x 3/32" wd x 3/16" h o/a; mts by shaft w/spring mtg hole near shoulder; curved type on 7/8" rad	Makes impression of character "3" on paper	N17-T-350013-834	CTT	150128	150128	0-1886	1	-	-	-	-	-
0-1887	PALLET, type; character (4); steel, nickel plated; Murray style type; approx 5/8" lg x 3/32" wd x 3/16" h o/a; mts by shaft w/spring mtg hole near shoulder; curved type on 7/8" rad	Makes impression of character "4" on paper	N17-T-350013-835	CTT	150129	150129	0-1887	1	-	-	-	-	-
0-1888	PALLET, type; character (5); steel, nickel plated; Murray style type; approx 5/8" lg x 3/32" wd x 3/16" h o/a; mts by shaft w/spring mtg hole near shoulder; curved type on 7/8" rad	Makes impression of character "5" on paper	N17-T-350013-836	CTT	150130	150130	0-1888	1	-	-	-	-	-
0-1889	PALLET, type; character (6); steel, nickel plated; Murray style type; approx 5/8" lg x 3/32" wd x 3/16" h o/a; mts by shaft w/spring mtg hole near shoulder; curved type on 7/8" rad	Makes impression of character "6" on paper	N17-T-350013-837	CTT	150131	150131	0-1889	1	-	-	-	-	-
0-1890	PALLET, type; character (7); steel, nickel plated; Murray style type; approx 5/8" lg x 3/32" wd x 3/16" h o/a; mts by shaft w/spring mtg hole near shoulder; curved type on 7/8" rad	Makes impression of character "7" on paper	N17-T-350013-838	CTT	150132	150132	0-1890	1	-	-	-	-	-
0-1891	PALLET, type; character (8); steel, nickel plated; Murray style type; approx 5/8" lg x 3/32" wd x 3/16" h o/a; mts by shaft w/spring mtg hole near shoulder; curved type on 7/8" rad	Makes impression of character "8" on paper	N17-T-350013-839	CTT	150133	150133	0-1891	1	-	-	-	-	-

CHANGE 1

8-165

TABLE 8-4. COMBINED PARTS AND SPARE PARTS LIST

SYMBOL DESIG.	NAME OF PART AND DESCRIPTION	FUNCTION	JAN OR NAVY TYPE DESIGNATION	PARTS			ALL SYMBOL DESIGNATIONS INVOLVED	SPARE PARTS					
				STANDARD NAVY STOCK NUMBER	MANUFAC- TURERS			TELETYPE PART NO.	TOTAL NO. PER EQUIP.	EQUIP.		STOCK	
					CODE	DESIG.				BOX	QUAN.	BOX	QUAN.
0-1892	PALLET, type: character (9); steel, nickel plated; Murray style type; approx 5/8" lg x 3/32" wd x 3/16" h o/a; mts by shaft w/spring mtg hole near shoulder; curved type on 7/8" rad	Makes impression of character "9" on paper		N17-T-350013-840	CTT	150134	150134	0-1892	1	-	-	-	-
0-1893	PALLET, type: character (.); steel, nickel plated; Murray style type; approx 5/8" lg x 3/32" wd x 3/16" h o/a; mts by shaft w/spring mtg hole near shoulder; curved type on 7/8" rad	Makes impression of character "." on paper		N17-T-350013-841	CTT	150135	150135	0-1893	1	-	-	-	-
0-1894	PALLET, type: character (,); steel, nickel plated; Murray style type; approx 5/8" lg x 3/32" wd x 3/16" h o/a; mts by shaft w/spring mtg hole near shoulder; curved type on 7/8" rad	Makes impression of character "," on paper		N17-T-350013-842	CTT	150136	150136	0-1894	1	-	-	-	-
0-1895	PALLET, type: character ("); steel, nickel plated; Murray style type; approx 5/8" lg x 3/32" wd x 3/16" h o/a; mts by shaft w/spring mtg hole near shoulder; curved type on 7/8" rad	Makes impression of character "" on paper		N17-T-350013-843	CTT	150137	150137	0-1895	1	-	-	-	-
0-1896	PALLET, type: character ((); steel, nickel plated; Murray style type; approx 5/8" lg x 3/32" wd x 3/16" h o/a; mts by shaft w/spring mtg hole near shoulder; curved type on 7/8" rad	Makes impression of character "(" on paper		N17-T-350013-844	CTT	150138	150138	0-1896	1	-	-	-	-
0-1897	PALLET, type: character (?); steel, nickel plated; Murray style type; approx 5/8" lg x 3/32" wd x 3/16" h o/a; mts by shaft w/spring mtg hole near shoulder; curved type on 7/8" rad	Makes impression of character "?" on paper		N17-T-350013-845	CTT	150139	150139	0-1897	1	-	-	-	-
0-1898	PALLET, type: character (ø); steel, nickel plated; Murray style type; approx 5/8" lg x 3/32" wd x 3/16" h o/a; mts by shaft w/spring mtg hole near shoulder; curved type on 7/8" rad	Makes impression of character "ø" on paper		N17-T-350013-846	CTT	150140	150140	0-1898	1	-	-	-	-
0-1899	PALLET, type: character ()); steel, nickel plated; Murray style type; approx 5/8" lg x 3/32" wd x 3/16" h o/a; mts by shaft w/spring mtg hole near shoulder; curved type on 7/8" rad	Makes impression of character ")" on paper		N17-T-350013-847	CTT	150141	150141	0-1899	1	-	-	-	-
0-1900	PALLET, type: character (£); steel, nickel plated; Murray style type; approx 5/8" lg x 3/32" wd x 3/16" h o/a; mts by shaft w/spring mtg hole near shoulder; curved type on 7/8" rad	Makes impression of character "£" on paper		N17-T-350013-848	CTT	150142	150142	0-1900	1	-	-	-	-

## PARTS LISTS

NAVSHIPS 91393

TT-47/UG, TT-48/UG, TT-69/UG, TT-70/UG

Section 8  
O-1901—O-1913

0-1901	PALLET, type: character (-); steel, nickel plated; Murray style type; approx 5/8" lg x 3/32" wd x 3/16" h o/a; mts by shaft w/spring mtg hole near shoulder; curved type on 7/8" rad	Makes impression of character "-" on paper	N17-T-350013-849	CTT	150143	150143	0-1901	1	-	-	-	-	-
0-1902	PALLET, type: character (§); steel, nickel plated; Murray style type; approx 5/8" lg x 3/32" wd x 3/16" h o/a; mts by shaft w/spring mtg hole near shoulder; curved type on 7/8" rad	Makes impression of character "§" on paper	N17-T-350013-850	CTT	150144	150144	0-1902	1	-	-	-	-	-
0-1903	PALLET, type: character (:); steel, nickel plated; Murray style type; approx 5/8" lg x 3/32" wd x 3/16" h o/a; mts by shaft w/spring mtg hole near shoulder; curved type on 7/8" rad	Makes impression of character ":" on paper	N17-T-350013-851	CTT	150145	150145	0-1903	1	-	-	-	-	-
0-1904	PALLET, type: character (!); steel, nickel plated; Murray style type; approx 5/8" lg x 3/32" wd x 3/16" h o/a; mts by shaft w/spring mtg hole near shoulder; curved type on 7/8" rad	Makes impression of character "!" on paper	N17-T-350013-852	CTT	150146	150146	0-1904	1	-	-	-	-	-
0-1905	PALLET, type: character (&); steel, nickel plated; Murray style type; approx 5/8" lg x 3/32" wd x 3/16" h o/a; mts by shaft w/spring mtg hole near shoulder; curved type on 7/8" rad	Makes impression of character "&" on paper	N17-T-350013-853	CTT	150147	150147	0-1905	1	-	-	-	-	-
0-1906	PALLET, type: character (;); steel, nickel plated; Murray style type; approx 5/8" lg x 3/32" wd x 3/16" h o/a; mts by shaft w/spring mtg hole near shoulder; curved type on 7/8" rad	Makes impression of character ";" on paper	N17-T-350013-854	CTT	150148	150148	0-1906	1	-	-	-	-	-
0-1907	PALLET, type: character (/); steel, nickel plated; Murray style type; approx 5/8" lg x 3/32" wd x 3/16" h o/a; mts by shaft w/spring mtg hole near shoulder; curved type on 7/8" rad	Makes impression of character "/" on paper	N17-T-350013-855	CTT	150149	150149	0-1907	1	-	-	-	-	-
0-1908	PALLET, type: character ('); steel, nickel plated; Murray style type; approx 5/8" lg x 3/32" wd x 3/16" h o/a; mts by shaft w/spring mtg hole near shoulder; curved type on 7/8" rad	Makes impression of character "'" on paper	N17-T-350013-856	CTT	150150	150150	0-1908	1	-	-	-	-	-
0-1909	Same as 0-1851	Retains 0-1911 in 0-1912											
0-1910	Same as 0-1846	Spaces 0-1909 and 0-1912											
0-1911	Same as 0-1850	Bearing balls for 0-1912											
0-1912	Same as 0-1849	Roller for 0-1848											
0-1913	Same as 0-1851	Retains 0-1911 in 0-1912											

CHANGE 1

8-167



8-168

CHANGE 1

TABLE 8-4. COMBINED PARTS AND SPARE PARTS LIST

SYMBOL DESIG.	NAME OF PART AND DESCRIPTION	FUNCTION	JAN OR NAVY TYPE DESIGNATION	STANDARD NAVY STOCK NUMBER	MANUFAC- TURERS		TELETYPE PART NO.	ALL SYMBOL DESIGNATIONS INVOLVED	TOTAL NO. PER EQUIP.	SPARE PARTS			
					CODE	DESIG.				EQUIP.		STOCK	
										BOX	QUAN.	BOX	QUAN.
0-1914	LEVER: steel; irregular shape, c/o arm w/formed ear and body ear, lever w/fin on end, and link w/ear on end and middle, all parts riveted together, hub welded to link; approx 4 1/2" lg x 1 1/4" h x 1 1/16" wd o/a; mts by two elongated slots in arm, one slot open at one end; RH mtg, two tapped holes in formed ear, one csk hole in ear at end of link	Operates A-1329		N17-T-350014-661	CTT	150397	150397	0-1914	1	1	1	-	-
0-1915	SPACER: steel, nickel plated; approx 1/4" lg x 5/16" OD x 1/8" ID o/a; mts by ID	Spaces 0-1914, and right side frame		N17-T-350014-656	CTT	150384	150384	0-1915	1	-	-	-	-
0-1916	Same as 0-255	Lubricates 0-1914											
0-1917	PLATE: steel, nickel plated; approx 1 7/32" lg x 15/32" wd x 0.035" thk o/a; mts by slot and hole	Retains 0-1918 in 0-1914		N17-T-350013-899	CTT	151602	151602	0-1917, 0-2000	3	-	-	-	-
0-1918	BLOCK, guide: steel; approx 23/32" lg x 7/32" wd x 1/8" thk o/a; mts by body hole near ea end	Guide for 0-1914		N17-T-350013-739	CTT	151604	151604	0-1918, 0-1999	2	-	-	-	-
0-1919	BLOCK, guide: steel; approx 7/32" sq x 3/32" thk o/a; mts by hole through ctr	Guide for 0-1914		N17-T-350014-654	CTT	150382	150382	0-1919, 0-1998	2	-	-	-	-
0-1920	SPACER: steel, nickel plated; approx 5/16" OD x 1/8" ID x 5/32" thk o/a; mts by ID	Spaces 0-1914, and right side frame		N17-T-350013-738	CTT	151603	151603	0-1920	2	-	-	-	-
0-1921	LINK: steel, nickel plated; bent near ctr w/rounded ends; approx 3 3/8" lg x 9/16" h x 3/32" wd o/a, 0.042" thk material; mts by hole at each end	Operates A-1307		N17-T-350014-650	CTT	150387	150387	0-1921	1	-	-	-	-
0-1922	LEVER: steel, nickel plated; irregular shape, four "V" shaped notches on bent side, rounded ear on other side near rounded end; approx 1 7/8" lg x 1" h x 0.065" thk o/a; mtg slot in rounded end and hole in rounded ear	Latch for 0-1914		N17-T-350014-673	CTT	150425	150425	0-1922, 0-2013	2	-	-	-	-
0-1923	Same as 0-1539	Lubricates 0-1924											
0-1924	SPRING: helical extension type; 0.026" diam music wire; approx 5/8" lg x 7/32" OD x 3/16" ID o/a; 11 turns; hook term ea end, indexed 90°; mts by terms	Applies tension to 0-1914 0-1925		N17-S-46712-8201	CTT	151644	151644	0-1924, 0-2001	2	1	1	-	-

8 Section  
0-1914-0-1924

TT-47/UG, TT-48/UG, TT-69/UG, TT-70/UG

NAVSHIPS 91393

PARTS LISTS

## PARTS LISTS

NAVSHIPS 91393

TT-47/UG, TT-48/UG, TT-69/UG, TT-70/UG

Section 8  
O-1925—O-1937

0-1925	BRACKET: irregular shape; steel, nickel plated; approx 2 1/4" lg x 1 7/16" h x 7/8" wd o/a, 0.065" thk material; mts by one elongated and one body hole in body; formed arm w/spring post riveted at end and body hole in ea of two curves	Operates 0-1928	N17-T-350014-643	CTT	150367	150367	0-1925	1	-	-	-	-	-
0-1926	ARM: steel, nickel plated; irregular shape, bent near one end; approx 2 1/4" lg x 3/4" h x 0.042" thk o/a; mts by hole near one end; elongated slot w/squared notch on ea end in bent end of arm	Operates 0-2016	N17-T-350014-280	CTT	150799	150799	0-1926, 0-2008	2	-	-	-	-	-
0-1927	Same as 0-196	Lubricates 0-1921											
0-1928	LINK: steel, nickel plated; rounded ends, body curved near ctr, stud welded to one end, hub welded to other end; approx 2 1/16" lg x 3/4" h x 1/4" wd o/a, 0.042" thk material; mts by ID of hub; LH mtg	Operates 0-1930	N17-T-350014-645	CTT	150370	150370	0-1928	1	-	-	-	-	-
0-1929	Same as 0-255	Lubricates 0-1930											
0-1930	LEVER: steel, nickel plated; irregular shape w/"C" shaped ctr, curved formed ear back of "C", three hubs and stud welded to body; approx 4 3/16" lg x 1 1/16" h x 5/16" wd o/a, 0.042" thk material; mts by ID of hub near elongated hole; elongated hole one end and two body holes (ID of hubs) in other half of body, RH mtg	Operates 0-1914, 0-1921, 0-1926, and 0-1933	N17-T-350014-672	CTT	150420	150420	0-1930	1	-	-	-	-	-
0-1931	BUSHING: steel, nickel plated; male and female; approx 5/16" OD x 1/8" ID x 3/32" lg o/a, 7/32" diam body	Pivot for 0-1926	N17-T-350014-533	CTT	150390	150390	0-1931, 0-2007	2	-	-	-	-	-
0-1932	Same as 0-255	Lubricates 0-1914 and 0-1928											
0-1933	ARM: steel, nickel plated; irregular shape w/two rounded and one "L" shaped projections; approx 1 5/8" lg x 1 1/2" h x 1/2" wd o/a, 0.065" thk material; mts by ID of hub welded to a rounded projection; one body and two tapped holes irregularly placed, RH mtg	Operates 0-1922	N17-T-350014-669	CTT	150413	150413	0-1933	1	-	-	-	-	-
0-1934	SPRING: helical extension type; 0.016" diam music wire; approx 15/16" lg x 5/32" OD o/a; approx 39 turns; hook terms, indexed 90°; mts by terms	Applies tension to 0-1933		CTT	76379	76379	0-1934, 0-2011	2	-	-	-	-	-
0-1935	STUD: steel, nickel plated; approx 9/16" lg x 1/4" across flats o/a; #6-40 thd through ID	Pivot for 0-1933	N17-T-350013-926	CTT	150811	150811	0-1935	1	-	-	-	-	-
0-1936	BLOCK, bearing: steel, nickel plated; squared one end, round on other w/roller bearing press fitted near end; approx 7/8" lg x 3/4" h x 3/8" wd o/a; mts by two tapped holes in block	Bearing for 0-2017	N17-T-350014-319	CTT	150891	150891	0-1936	1	-	-	-	-	-
0-1937	Same as 0-255	Lubricates 0-1936 and 0-2017											

CHANGE 1

8-169

8-170

CHANGE 1

TABLE 8-4. COMBINED PARTS AND SPARE PARTS LIST

SYMBOL DESIG.	NAME OF PART AND DESCRIPTION	FUNCTION	JAN OR NAVY TYPE DESIGNATION	STANDARD NAVY STOCK NUMBER	MANUFAC- TURERS		TELETYPE PART NO.	ALL SYMBOL DESIGNATIONS INVOLVED	SPARE PARTS										
					CTB CO	DESIG.			TOTAL NO. PER EQUIP.	EQUIP.		STOCK							
										BOX	QUAN.	BOX	QUAN.						
0-1938	Same as 0-295	Lubricates 0-1790																	
0-1939	Same as 0-255	Lubricates right side of 0-1940																	
0-1940	SHAFT: steel, nickel plated; square shaft with slot between round shoulder and shank on both ends; approx 10" long x 5/16" sq o/a; mts by shank on ends; 2 tapped holes and 4 body holes	Operates 0-1943 and 0-1946		N17-T- 350014- 239	CTT	150723	150723	0-1940	1	-	-	-	-	-	-	-	-	-	-
0-1941	Same as 0-255	Lubricates left side of 0-1940																	
0-1942	BRACKET: "L" shape; steel, nickel plated; approx 1 1/16" lg x 1/2" h x 3/8" wd o/a, 0.095" thk material; mts by body hole and slot in lg end; tapped hole in short rounded end	Operates 0-1940		N17-T- 350014- 802	CTT	150418	150418	0-1942	1	-	-	-	-	-	-	-	-	-	-
0-1943	BRACKET: "L" shape; steel, nickel plated; approx 1 1/4" lg x 3/4" h x 5/16" wd o/a, 0.065" thk material; mts by 2 tapped holes on side w/squared end; pin welded near rounded end	Operates 0-1948		N17-T- 350014- 671	CTT	150416	150416	0-1943, 0-1946	2	1	1	-	-	-	-	-	-	-	-
0-1944	POST, pivot: aluminum, plain anodized; c/o head, shoulder, body and shank; approx 1" OD x 3/16" ID x 7/8" lg o/a; mts by ID; two holes in shoulder and ctb hole through side of body	Mounts 0-1957		N17-T- 350014- 739	CTT	150423	150423	0-1944	1	-	-	-	-	-	-	-	-	-	-
0-1945	POST, pivot: aluminum, plain anodize; c/o head, shield, body, shank; approx 1" OD x 3/16" ID x 1 5/32" lg o/a; mts by ID; 2 holes in shield and ctb hole through side of body	Mounts 0-1958		N17-T- 350014- 662	CTT	150398	150398	0-1945	1	-	-	-	-	-	-	-	-	-	-
0-1946	Same as 0-1943	Operates 0-1947																	
0-1947	LINK: steel, nickel plated; approx 3/4" lg x 3/8" wd x 0.065" thk o/a; mts by two body holes; radial cutout on both sides, circular ends	Operates left end of 0-1953		N17-T- 350014- 705	CTT	150388	150388	0-1947, 0-1948	2	-	-	-	-	-	-	-	-	-	-
0-1948	Same as 0-1947	Operates right end of 0-1953																	
0-1949	SPACER: steel, black nickel finish; approx 5/16" OD x 5/32" ID x 1/16" thk o/a; mts by ID	Spaces 0-1947 and left end of 0-1953		N17-T- 350013- 608	CTT	2481	2481	0-1949, 0-1950	2	1	1	-	-	-	-	-	-	-	-
0-1950	Same as 0-1949	Spaces 0-1948 and right end of 0-1953																	

8 Section  
0-1938—0-1950

TT-47/UG, TT-48/UG, TT-69/UG, TT-70/UG

NAVSHIPS 91393

PARTS LISTS

CHANGE 1

8-171

0-1951	WASHER, felt: hard, white felt; round approx 7/16" OD x 5/16" ID x 1/32" thk o/a	Lubricates 0-1948 and 0-1950	N17-T-350014-338	CTT	150930	150930	0-1951, 0-1952	2	1	2	-	-	-	-	-
0-1952	Same as 0-1951	Lubricates 0-1947 and 0-1949													
0-1953	BALL: steel, nickel plated; irregular shape, side of body formed w/formed arm at ea end w/ear in ea arm; approx 9 1/4" lg x 1 3/4" h x 7/8" wd o/a, 0.065" thk material; mts by hole in ea arm; hole in ea ear	Resets and releases 0-1406 through 0-1416	N17-T-350013-597	CTT	150724	150724	0-1953	1	-	-	-	-	-	-	-
0-1954	Same as 0-1734	Right side frame bearing for 0-1940													
0-1955	Same as 0-1734	Left side frame bearing for 0-1940													
0-1956	Same as 0-255	Lubricates 0-1957 and 0-1953													
0-1957	SHAFT: steel; approx 1 3/16" lg x 3/16" diam o/a; mts by tapped hole in ctr	Right end pivot for 0-1953	N17-T-350014-534	CTT	150419	150419	0-1957, 0-1958	2	-	-	-	-	-	-	-
0-1958	Same as 0-1957	Left end pivot for 0-1953													
0-1959	Same as 0-255	Lubricates 0-1958 and 0-1953													
0-1960	ROD: aluminum, plain anodized; approx 10" lg x 5/16" across flats o/a; mts by tapped hole ea end	Tie bar for right and left side frames	N17-T-350013-751	CTT	151627	151627	0-1960	1	-	-	-	-	-	-	-
0-1961	SPINDLE, paper: steel, nickel plated; hex tubing w/flat spring riveted on one side w/ends inserted in body holes, bracket welded on by three ears on one end; approx 9 7/16" lg x 1 7/16" diam o/a, 13/16" across flats; mts by ends	Holds roll paper	N17-T-350013-891	CTT	150907	150907	0-1961	1	-	-	-	-	-	-	-
0-1962	BLOCK, guide: black bakelite; cutout and irregular shaped groove one side, other sides straight; approx 3 1/4" lg x 1 1/8" h x 5/8" wd o/a; mts by two body holes along length of groove; ctb hole between cutout and end, two body holes opposite side of cutout, RH mtg	Mounts 0-1961 to right side frame	N17-T-350014-326	CTT	150904	150904	0-1962	1	-	-	-	-	-	-	-
0-1963	SPRING: helical compression type; 0.020" diam music wire; approx 1 1/2" lg x 5/32" OD x 1/8" ID o/a; approx 28 turns; right hand; closed ends; mts by ID	Applies pressure to 0-1965	N17-T-350013-617	CTT	85407	85407	0-1963, 0-1968	2	1	1	-	-	-	-	-
0-1965	PLATE: steel, nickel plated; irregular shape w/wing and formed ear; approx 2 1/8" lg x 7/8" h x 1/4" wd o/a, 0.065" thk material; mts by 2 elongated slots, one w/rounded cut-out at one end; RH mtg	Retains 0-1961 to 0-1962	N17-T-350014-329	CTT	150910	150910	0-1965	1	-	-	-	-	-	-	-
0-1966	Same as 0-1583	Roller and guide for 0-1965 and locks H-1455 to right side frame													

PARTS LISTS

TT-47/UG, TT-48/UG, TT-69/UG, TT-70/UG

NAVSHIPS 91393

0-1951-O-1966

Section 8

TABLE 8-4. COMBINED PARTS AND SPARE PARTS LIST

PARTS										SPARE PARTS			
SYMBOL DESIG.	NAME OF PART AND DESCRIPTION	FUNCTION	JAN OR NAVY TYPE DESIGNATION	STANDARD NAVY STOCK NUMBER	MANUFAC- TURERS		TELETYPE PART NO.	ALL SYMBOL DESIGNATIONS INVOLVED	TOTAL NO. PER EQUIP.	EQUIP.		STOCK	
					HE D C	DESIG.				BOX	QUAN.	BOX	QUAN.
0-1967	BLOCK, guide: black bakelite; cutout and irregular shaped groove one side, other sides straight; approx 3 1/4" lg x 1 1/8" h x 7/8" wd o/a; mts by 2 holes along length of groove; ctb hole between cutout and end, LH mtg	Mounts 0-1961 to left side frame		N17-T-350014-325	CTT	150903	150903	0-1967	1	-	-	-	-
0-1968	Same as 0-1963	Applies pressure to 0-1970											
0-1970	PLATE: steel, nickel plated; irregular shape w/wing and formed ear; approx 2 1/8" lg x 7/8" h x 1/4" wd o/a, 0.065" thk material; mts by 2 elongated slots, one w/rounded cutout at one end; LH mtg	Retains 0-1961 to 0-1967		N17-T-350013-892	CTT	150935	150935	0-1970	1	-	-	-	-
0-1971	Same as 0-1583	Roller and guide for 0-1965											
0-1972	PLATEN, teletypewriter: aluminum, rubber coated; rubber coated aluminum tube w/hub pressed into both ends; approx 10 5/8" lg x 1 3/4" OD o/a; mts by shanks; longer hub has 3 tapped holes in body and one tapped hole in shank	Platen for 0-1858 through 0-1908 and advances paper		N17-T-350013-946	CTT	150718	150718	0-1972	1	-	-	-	-
0-1973	BUSHING: bronze; male and female; approx 5/8" OD x 3/8" ID x 3/8" lg o/a, groove in head, 1/2" diam body	Right side frame pivot bushing for 0-1972		N17-T-350014-703	CAID	A-649-6	150714	0-1973, 0-1979	2	-	-	-	-
0-1974	RETAINER: steel, nickel plated; irregular shape w/2 formed ears; approx 1 9/16" lg x 1 1/8" h x 1/16" wd o/a, 0.032" thk material; mts by hole in ea end; LH mtg	Retains 0-1973 to right side frame		N17-T-350013-947	CTT	150719	150719	0-1974	1	-	-	-	-
0-1975	Same as 0-284	Applies tension to 0-1976											
0-1976	LEVER: steel, nickel plated; irregular shape w/cutout, body ear and one formed ear w/1 notch; approx 3 5/8" lg x 1 1/2" h x 1/4" wd o/a, 0.065" thk material; mts by body hole	Operates 0-1986		N17-T-350014-195	CTT	150586	150586	0-1976	1	-	-	-	-
0-1977	DISK, spacing: steel, nickel plated; approx 1 3/4" OD x 1/2" ID x 0.020" thk o/a; mts by ID; three equidistant body holes	Spaces 0-1972 and 0-1978		N17-T-350014-365	CTT	150998	150998	0-1977	1	-	-	-	-
0-1978	GEAR: spur; steel, nickel plated; straight teeth; 32 teeth; 20 pitch, 1.60 PD; approx 1 11/16" OD x 1/2" ID x 9/32" thk o/a; straight face, dished out in back; mts by ID, 3 body holes	Operates 0-1972 automatically		N17-T-350014-288	CTT	150809	150809	0-1978	1	-	-	-	-
0-1979	Same as 0-1973	Left side frame pivot bushing for 0-1972											

8-172

CHANGE 1

CHANGE 1

0-1980	GEAR: spur; steel, nickel plated; c/o hub and gear; straight teeth; 32 teeth; 24 pitch, 1.33" PD; approx 1 13/32" OD x 3/8" ID x 3/16" wd o/a, 0.065" thk material; straight face; hub 1/2" OD x 3/8" ID x 1/4" wd o/a with 9/64" hole one side; mts by ID	Operates 0-1972 manually	N17-T-350013-945	CTT	150715	150715	0-1980	1	-	-	-	-	-
0-1981	BUSHING: stainless steel; male and female; approx 3/8" OD x 1/8" ID x 1/8" lg o/a, 1/4" diam body	Spaces 0-1976 and 0-1982 from left side frame	N17-T-350013-961	CTT	150911	150911	0-1981	1	-	-	-	-	-
0-1982	GEAR: spur; steel, nickel plated; straight teeth; 21 teeth; 24 pitch, 0.87" PD; approx 1" OD x 3/16" ID x 0.065" thk o/a; straight face; 2 #4-40 tapped holes	Operates 0-1985	N17-T-350013-931	CTT	150658	150658	0-1982	1	-	-	-	-	-
0-1983	HANDWHEEL: molded black bakelite; 30 grooves equally spaced along OD, dished in on one side; approx 1 3/8" OD x 3/16" ID x 1" lg o/a; mts by ID ctb on dished side; 2 body holes through length	Operates 0-1972 manually through 0-1982, 0-1985 and 0-1980	N17-T-350013-930	CTT	150656	150656	0-1983	1	-	-	-	-	-
0-1984	RETAINER: steel, nickel plated; irregular shape w/2 formed ears; approx 1 9/16" lg x 1 1/8" h x 1/16" wd o/a, 0.032" thk material; mts by hole in ea end; RH mtg	Retains 0-1979 to left side frame	N17-T-350014-238	CTT	150720	150720	0-1984	1	-	-	-	-	-
0-1985	GEAR: spur; steel, nickel plated; straight teeth; 28 teeth; 28 pitch, 1.16" PD; approx 1 1/4" OD x 7/32" ID x 1/16" thk o/a; straight face; mts by ID	Operates 0-1980	N17-T-350013-934	CTT	150666	150666	0-1985	1	-	-	-	-	-
0-1986	BELL CRANK: steel, nickel plated; irregular shape w/l end formed w/V notch, roller mtd by pin riveted near round end; approx 1 1/2" lg x 5/8" h x 5/16" wd o/a, 0.058" thk material; mts by hole in round end	Positions 0-1989 or 0-1991	N17-T-350014-191	CTT	150642	150642	0-1986	1	-	-	-	-	-
0-1987	SPRING: helical extension type; 0.018" diam music wire; approx 1" lg x 5/32" OD x 1/8" ID o/a; approx 36 turns; parallel hook term ea end; mts by terms	Applies tension to 0-1986	N17-T-350013-606	CTT	22015	22015	0-1987	1	1	1	-	-	-
0-1988	ECCENTRIC: steel, nickel plated; approx 7/8" OD x 5/16" ID x 0.020" thk o/a; mts by large hole off ctr; 2 body holes off ctr	Retains 0-1990 in 0-1989	N17-T-350014-189	CTT	150647	150647	0-1988	1	-	-	-	-	-
0-1989	BAR, line feed: steel, nickel plated; irregular shape w/3 teeth; approx 4 5/8" lg x 1" wd x 0.060" thk o/a; mts by hole in round end; elongated slot in body	Operates 0-1978 and 0-1986	N17-T-350013-587	CTT	150585	150585	0-1989, 0-1991	2	-	-	-	-	-
0-1990	ECCENTRIC: oilite; approx 3/4" OD x 5/16" ID x 0.064" thk o/a; mts by large hole off ctr; 2 body holes off ctr	Operates 0-1989	N17-T-350014-188	CTT	150648	150648	0-1990, 0-1992	2	-	-	-	-	-
0-1991	Same as 0-1989	Operates 0-1978 and 0-1986											
0-1992	Same as 0-1990	Operates 0-1991											

8-173

PARTS LISTS

TT-47/UG, TT-48/UG, TT-69/UG, TT-70/UG

NAVSHIPS 91393

0-1980-0-1992

Section 8

TABLE 8-4. COMBINED PARTS AND SPARE PARTS LIST

SYMBOL DESIG.	NAME OF PART AND DESCRIPTION	FUNCTION	JAN OR NAVY TYPE DESIGNATION	STANDARD NAVY STOCK NUMBER	MANUFAC- TURERS		TELETYPE PART NO.	ALL SYMBOL DESIGNATIONS INVOLVED	SPARE PARTS				
					CODE	DESIG.			TOTAL NO. PER EQUIP.	EQUIP.		STOCK	
										BOX	QUAN.	BOX	QUAN.
0-1993	BUSHING: phosphor bronze; approx 5/8" lg x 7/8" OD x 1/4" ID o/a, 5/16" diam and 11/32" diam shafts on ends	Mounts H-1988, O-1944 and O-1988 through O-1992		N17-T-350014-261	CTT	150650	150650	0-1993	1	-	-	-	-
0-1994	GEAR: spur; steel, nickel plated; straight teeth; 28 teeth; 24 pitch, 1.16" PD; approx 1 1/4" OD x 3/8" ID x 1/8" thk o/a; straight; two #4-40 tapped holes	Operates O-1992 and O-1990		N17-T-350014-552	CTT	150651	150651	0-1994	1	-	-	-	-
0-1995	LEVER: steel; irregular shape, c/o arm w/formed ear and body ear, lever w/fin on end, and link w/ear on end and middle, all parts riveted together, hub welded to link; approx 4 1/2" lg x 1 1/4" h x 1 1/16" wd o/a; mts by two elongated slots in arm, one slot open at one end; LH mtg, two tapped holes in formed ear, one csk hole in ear at end of link	Operates A-1329		N17-T-350014-660	CTT	150396	150396	0-1995	1	1	1	-	-
0-1996	SPACER: steel, nickel plated; approx 5/32" lg x 5/16" OD x 1/8" ID o/a; mts by ID	Spaces O-1995 and left side frame		N17-T-350014-655	CTT	150383	150383	0-1996	3	-	-	-	-
0-1997	Same as 0-1326	Lubricates O-1995											
0-1998	Same as 0-1919	Guide for O-1995											
0-1999	Same as 0-1918	Guide for O-1995											
0-2000	Same as 0-1917	Retains O-1999 in O-1995											
0-2001	Same as 0-1924	Applies tension to O-1995											
0-2002	Same as 0-1539	Lubricates O-2001											
0-2003	LINK: steel, nickel plated; rounded ends, body curved near ctr, stud welded to one end, hub welded to other end; approx 2 1/16" lg x 3/4" h x 1/4" wd o/a, 0.042" thk material; mts by ID of hub; RH mtg	Operates O-2004		N17-T-350014-644	CTT	150369	150369	0-2003	1	-	-	-	-
0-2004	LEVER: steel, nickel plated; irregular shape w/"C" shaped ctr, curved formed ear back of "C", 3 hubs and stud welded to body; approx 4 3/16" lg x 1 1/16" h x 5/16" wd o/a, 0.042" thk material; mts by ID of hub near elongated hole, elongated hole one end and 2 body holes (ID of hubs) in other half of body, LH mtg	Operates O-1995, O-2005, O-2008 and O-2010		N17-T-350014-675	CTT	150428	150428	0-2004	1	-	-	-	-
0-2005	LINK: steel, nickel plated; straight one side, cutout other side, rounded ends, body formed from ends; approx 3 3/8" lg x 3/8" h x 13/32" wd o/a, 0.042" thk material; mts by hole at ea end	Operates A-1306		N17-T-350014-649	CTT	150386	150386	0-2005	1	-	-	-	-

8-174

CHANGE 1

## PARTS LISTS

NAVSHIPS 91393

TT-47/UG, TT-48/UG, TT-69/UG, TT-70/UG

Section 8  
O-2006-O-2020

0-2006	Same as 0-1326	Lubricates 0-2004																		
0-2007	Same as 0-1931	Pivot for 0-2008																		
0-2008	Same as 0-1926	Operates 0-2016																		
0-2009	BRACKET: irregular shape; steel, nickel plated; approx 1 1/4" wd x 1 3/4" h x 1 3/8" lg o/a, 0.095" thk material; mts by 2 elongated holes in body; one end formed, formed arm w/2 holes and stud riveted at bend	Operates 0-2017 and 0-2003	N17-T-350014-642	CTT	150366	150366	0-2009	1	-	-	-	-	-	-	-	-	-	-	-	-
0-2010	ARM: steel, nickel plated; irregular shape w/2 rounded and one "L" shaped projections; approx 1 5/8" lg x 1 1/2" h x 1/2" wd o/a; 0.065" thk material; mts by ID of hub welded to a rounded projection; one body and 2 tapped holes irregularly placed, LH mtg	Operates 0-2013	N17-T-350014-668	CTT	150412	150412	0-2010	1	-	-	-	-	-	-	-	-	-	-	-	-
0-2011	Same as 0-1934	Applies tension to 0-2010																		
0-2012	Same as 0-1326	Lubricates 0-1995 and 0-2003																		
0-2013	Same as 0-1922	Latch for 0-1995																		
0-2014	Same as 0-1756	Left side frame bearing for 0-2017																		
0-2015	Same as 0-1583	Roller and guide for 0-1965																		
0-2016	BLADE, bail: steel, nickel plated; approx 11 3/16" lg x 7/8" wd x 3/16" h o/a, 0.050" thk material; mts by ear at ea end; elongated cutout and two small notches one side, stud riveted below notches, elongated slot below stud, indented lengthwise along ctr	Strips 0-1433 and 0-1445 through 0-1454 from 0-1406 through 0-1416	N17-T-350014-837	CTT	150424	150424	0-2016	1	-	-	-	-	-	-	-	-	-	-	-	-
0-2017	SHAFT: steel, nickel plated; sq body w/ rounded ends, cutout one end, bushing pressed on other end; approx 11 3/4" lg x 3/8" sq o/a; mts by 2 tapped holes in cutout and 2 tapped holes in body near other end; 2 body holes and 2 tapped holes	Operates 0-1530, 0-2018 and 0-1925	N17-T-350014-641	CTT	150365	150365	0-2017	1	-	-	-	-	-	-	-	-	-	-	-	-
0-2018	PLATE, cam: steel, nickel plated; rectangular shape w/formed ear one side; approx 7/8" lg x 5/8" h x 3/32" wd o/a, 0.042" thk material; mts by 2 elongated slots	Operates 0-2051	N17-T-350014-639	CTT	150363	150363	0-2018	1	-	-	-	-	-	-	-	-	-	-	-	-
0-2019	SPRING: helical extension type; 0.014" diam music wire; approx 1 1/8" lg x 3/16" OD o/a; approx 58 turns; hook terms indexed 90°; mts by term at ea end	Applies tension to 0-2021 through H*2018	N17-T-350006-397	CTT	7634	7634	0-2019, 0-2023	2	1	1	-	-	-	-	-	-	-	-	-	-
0-2020	WASHER, felt: hard, white felt; round, 3/16" ID x 9/16" OD x 1/32" thk o/a	Lubricates right end of 0-2021	N17-T-350005-817	CTT	90752	90752	0-2020, 0-2022	2	1	1	-	-	-	-	-	-	-	-	-	-

CHANGE 1

8-175



TABLE 8-4. COMBINED PARTS AND SPARE PARTS LIST

SYMBOL DESIG.	NAME OF PART AND DESCRIPTION	FUNCTION	JAN OR NAVY TYPE DESIGNATION	STANDARD NAVY STOCK NUMBER	MANUFACTURERS		TELETYPE PART NO.	ALL SYMBOL DESIGNATIONS INVOLVED	SPARE PARTS				
					CODE	DESIG.			TOTAL NO. PER EQUIP.	EQUIP.		STOCK	
										BOX	QUAN.	BOX	QUAN.
0-2021	BAIL: steel, nickel plated; both ends formed, strip copper brazed in place along ctr of bail; approx 9 7/8" lg x 1 1/4" h x 5/16" wd o/a, 0.065" thk material; mts by 2 large holes in line at ends; 2 small holes in line in formed ends	Operates 0-2024		N17-T-350014-277	CTT	150792	150792	0-2021	1	-	-	-	-
0-2022	Same as 0-2020	Lubricates left end of 0-2021											
0-2023	Same as 0-2019	Applies tension to 0-2021 through H-2048											
0-2024	SLIDE: steel, nickel plated; irregular shape, body ear at bend w/pin riveted below; approx 2 7/8" lg x 15/16" h x 3/16" wd o/a, 0.050" thk material; mts by elongated hole in rounded end	Prevents 0-2036 from latching 0-1711		N17-T-350014-678	CTT	150433	150433	0-2024	1	1	1	-	-
0-2025	BAR, guide: steel, nickel plated; approx 10" lg x 1/2" wd x 3/16" thk o/a; mts by 2 tapped holes in ea end; notch in side near ea end, 3 slots crossing width ea end at notches, 5 tapped holes ctb opposite side of slots	Guide for 0-2031, 0-2034 and 0-2035		N17-T-350014-320	CTT	150894	150894	0-2025	1	-	-	-	-
0-2026	BAIL: steel, nickel plated; irregular "U" shape, both sides extend in different directions, one formed at end, elongated cutout and formed ear on end of other side; approx 1 5/16" lg x 1/2" h x 1 1/4" wd o/a, 0.065" thk material; mts by two holes in line in sides of "U"	Operates 0-2030		N17-T-350014-679	CTT	150434	150434	0-2026	1	-	-	-	-
0-2027	SPRING: helical extension type; 0.012" diam music wire; approx 5/8" lg x 5/32" OD x 1/8" ID o/a; approx 28 turns; parallel hook term ea end; mts by terms	Applies tension to 0-2026		N17-T-350006-542	CTT	82463	82463	0-2027	1	1	1	-	-
0-2028	WASHER, felt: hard, white felt; round, approx 9/16" OD x 3/16" ID x 1/8" thk o/a	Lubricates 0-2026		N17-T-350013-607	CTT	4586	4586	0-2028	2	1	1	-	-
0-2029	Same as 0-255	Lubricates 0-2030											
0-2030	BAIL: steel, nickel plated; one end "U" formed w/1 side longer and formed at end; approx 1 5/8" lg x 5/8" wd x 1/2" h o/a, 0.050" thk material; mts by 2 holes in line in sides of "U"; formed ear on one side of "U"	Operates 0-2024		N17-T-350014-278	CTT	150793	150793	0-2030	1	-	-	-	-

8-176

CHANGE 1

## PARTS LISTS

NAVSHIPS 91393

TT-47/UG, TT-48/UG, TT-69/UG, TT-70/UG

Section 8  
O-2031—O-2043

0-2031	ARM: steel, nickel plated; irregularly shaped and formed body, ear at narrow end; approx 2 1/16" lg x 3/8" wd x 5/16" h o/a, 0.042" thk material; mts by rectangular slot at wd end of body	Operates 0-2048	N17-T-350014-651	CTT	150377	150377	0-2031	1	-	-	-	-	-
0-2032	BRACKET: irregular shape; steel, nickel plate; approx 3 9/16" lg x 1 13/16" h x 2 5/16" wd o/a, 0.095" thk material; mts by 2 tapped holes and 1 body hole in formed arm and 2 tapped holes in formed end; 5 body holes csk both sides	Holds 0-2031 to 0-2025, mounts one end of 0-1706 and anchor for 0-1698, 0-1744, 0-1718, 0-1714 and 0-1707	N17-T-350014-635	CTT	150357	150357	0-2032	1	-	-	-	-	-
0-2033	LEVER: steel, nickel plated; "L" shaped lever w/hub welded to corner and push bar w/formed end riveted to one end of lever; approx 3 5/8" lg x 1" h x 1/2" wd o/a; mts by ID of hub; csk hole in narrow p/o "L"	Operates 0-213	N17-T-350014-196	CTT	150581	150581	0-2033	1	-	-	-	-	-
0-2034	ARM: steel, nickel plated; approx 1 1/16" lg x 3/16" wd x 0.042" thk o/a; mts by lg cutout along one side of body; ear one end of mtg cutout	Operates 0-2033	N17-T-350013-579	CTT	150561	150561	0-2034	1	-	-	-	-	-
0-2035	ARM: steel, nickel plated; bent one end, lg narrow arm extending up other end, elongated cutout along one side; approx 1" lg x 3/8" wd x 1/8" thk o/a; mts by body along cutout	Operates 0-1725	N17-T-350014-562	CTT	150919	150919	0-2035	1	-	-	-	-	-
0-2036	LEVER: steel, nickel plated; irregular shape, one end curved w/v notch, other end has elongated cutout, arm extends from body near ctr; approx 2 1/2" lg x 1 3/4" h x 1/8" wd o/a, 0.050" thk material; mts by hole in approx crt, ctb on one side	Operates 0-1711	N17-T-350014-275	CTT	150790	150790	0-2036	1	-	-	-	-	-
0-2037	Same as 0-284	Applies tension to 0-2037											
0-2038	BUSHING: steel, nickel plated; male and female; approx 5/16" OD x 1/8" ID x 1/8" lg o/a, 1/4" diam body	Pivot for 0-2036	N17-T-350013-925	CTT	150778	150778	0-2038	1	-	-	-	-	-
0-2039	WASHER, felt: hard, white felt; round, approx 9/16" OD x 9/32" ID x 1/32" thk o/a	Lubricates 0-2036	N17-T-350014-333	CTT	150924	150924	0-2039	1	-	-	-	-	-
0-2040	WICK: lubricating wick; hard, white felt, w/o spring; approx 1/2" lg x 1/4" wd x 1/16" thk o/a, elongated slot in ctr	Lubricates 0-2051 and 0-2036	N17-T-350005-830	CTT	93879	93879	0-2040	1	1	1	-	-	-
0-2041	SPRING: helical extension type; 0.022" diam music wire; approx 7/8" lg x 1/4" OD x 3/16" ID o/a; approx 18 turns; parallel hook term ea end; mts by terms	Applies tension to 0-2051	N17-T-350006-540	CTT	82442	82442	0-2041	1	1	1	-	-	-
0-2042	Same as 0-196	Lubricates 0-2051											
0-2043	BAIL: steel, nickel plated; irregular shape w/"U" formed end; approx 1 3/4" lg x 1/2" h x 5/8" wd o/a, 0.042" thk material; mts by two holes in line in side of "U"; two slots on sides near narrow end	Operates 0-2044	N17-T-350014-843	CTT	150913	150913	0-2043	1	-	-	-	-	-

CHANGE 1

8-177

8-178

CHANGE 1

TABLE 8-4. COMBINED PARTS AND SPARE PARTS LIST

PARTS										SPARE PARTS			
SYMBOL DESIG.	NAME OF PART AND DESCRIPTION	FUNCTION	JAN OR NAVY TYPE DESIGNATION	STANDARD NAVY STOCK NUMBER	MANUFAC- TURERS		TELETYPE PART NO.	ALL SYMBOL DESIGNATIONS INVOLVED	TOTAL NO. PER EQUIP.	EQUIP.		STOCK	
					CODE	DESIG.				BOX	QUAN.	BOX	QUAN.
0-2044	STRIPPER: steel, nickel plated; irregular shape, elongated cutout ea end; two formed ears each end; approx 1 5/8" lg x 1/8" h x 7/16" wd o/a; 0.042" thk material; mts by elongated slot in larger end; tapped hole near small end	Strips 0-1451 and 0-1452		N17-T-350014-844	CTT	150915	150915	0-2044	1	-	-	-	-
0-2045	SPRING: helical extension type; 0.014" diam music wire; approx 5/8" lg x 3/16" OD x 5/32" ID o/a; approx 26 turns; hook term ea end indexed 90°; mts by terms	Applies tension to 0-2033		N17-T-350006-401	CTT	7965	7965	0-2045	1	-	-	-	-
0-2046	LEVER: steel, nickel plated; two ears one end w/rounded cutout between, other end rounded w/lg irregular shaped arm; approx 2" lg x 1 1/2" wd x 3/32" thk o/a; mts by large body hole w/smaller hole on extruded side; tapped hole near cutout, csk hole in arm	Operates 0-1586		N17-T-350014-674	CTT	150426	150426	0-2046	1	-	-	-	-
0-2047	SPRING: helical extension type; 0.018" diam music wire; approx 13/16" lg x 1/4" OD x 7/32" ID o/a; approx 24 turns; hook term ea end indexed 90°; mts by terms	Applies tension to 0-2046		N17-T-350006-353	CTT	2623	2623	0-2047	1	1	1	-	-
0-2048	BAIL: steel, nickel plated; irregular shape, "U" formed near one end, ear at end; approx 3 5/16" lg x 3/4" h x 1 3/16" wd o/a, 0.050" thk material; mts by two holes in line in sides of "U"; body hole near ear	Operates 0-2046		N17-T-350014-658	CTT	150392	150392	0-2048	1	-	-	-	-
0-2049	Same as 0-255	Lubricates 0-2048											
0-2050	SHAFT: stainless steel; approx 3 3/8" lg x 1/4" diam o/a; mts by tapped hole in ea end; 2 body slots	Pivot for 0-2046 and 0-2048		N17-T-350014-663	CTT	150399	150399	0-2050	1	-	-	-	-
0-2051	BAIL: steel, nickel plated; irregular "U" shape, one side extends forward w/2 formed ears; other side has arm extending up; approx 1 1/4" lg x 5/8" wd x 7/8" h o/a; 0.065" thk material; mts by two holes in line in side of "U"; csk hole in one formed ear, tapped hole below "V" notched formed ear	Operates 0-2036		N17-T-350014-276	CTT	150791	150791	0-2051	1	-	-	-	-
0-2052	SPRING: torsion type; 0.022" diam music wire; approx 13/16" h x 3/8" lg x 7/32" wd o/a; 12 turns; RH; hooked ends; mts by ends	Applies tension to 0-2043		N17-T-350014-861	CTT	151713	151713	0-2052	1	1	1	-	-
0-2053	BUSHING: steel, nickel plated; male and female; approx 5/16" OD x 1/8" ID x 1/4" lg o/a, 3/16" diam shoulder	Pivot for and spaces 0-2054 from right side frame		N17-T-350014-557	CTT	150815	150815	0-2053, 0-2060	2	-	-	-	-

8 Section  
0-2044-0-2053

TT-47/UG, TT-48/UG, TT-69/UG, TT-70/UG

NAVSHIPS 91393

PARTS LISTS

CHANGE 1

8-179

0-2054	LEVER: steel, nickel plated finish; flat elongated shape w/bend in middle having small hole at ea end, one csk on both sides; approx 1 1/2" lg x 1 1/2" wd x 0.050" thk o/a; mts by large ctr hole	Bearing for and supports right end of 0-2057	N17-T-350014-289	CTT	150816	150816	0-2054, 0-2059	2	-	-	-	-	-
0-2055	Same as 0-102	Applies tension to 0-2054											
0-2056	COLLAR: aluminum, plain anodize finish; approx 1/4" lg x 5/8" OD x 1/4" ID; mts by ID; 2 tapped holes in sides	Right side guide for paper	N17-T-350013-940	CTT	150683	150683	0-2056, 0-2058	2	-	-	-	-	-
0-2057	SHAFT: aluminum plain anodize finish and steel; approx 10" lg x 1/4" diam o/a; mts by pin inserted in ea end	Supports 0-2056 and 0-2058 and guides paper to A-1334	N17-T-350013-939	CTT	150680	150680	0-2057	1	-	-	-	-	-
0-2058	Same as 0-2056	Left side guide for paper											
0-2059	Same as 0-2054	Bearing for and supports left end of 0-2057											
0-2060	Same as 0-2053	Pivot for and spaces 0-2059 from left side frame											
0-2061	Same as 0-102	Applies tension to 0-2059											
0-2062	Same as 0-1377	Pivot for 0-2063											
0-2063	LEVER: stainless steel; one end formed, round ear near round end, stud riveted to ear; approx 1 1/8" lg x 5/8" h x 1" wd o/a, 0.050" thk material; mts by hole in rounded end; formed end marked paper release	Operates 0-2069	N17-T-350013-978	CTT	150276	150276	0-2063	1	-	-	-	-	-
0-2064	SPRING: helical extension type; 0.024" diam music wire; approx 11/16" lg x 3/16" OD x 1/8" ID o/a; approx 15 turns; parallel hook term ea end; mts by terms	Applies tension to 0-2065	N17-T-350012-717	CTT	72468	72468	0-2064	1	1	1	-	-	-
0-2065	PLATE: steel; irregular shape w/formed ear w/"V" notch; approx 5/8" lg x 5/8" h x 10 1/2" wd o/a, 0.050" thk material; mts by shaft riveted to body	Mounts and operates 0-2066 and 0-2067	N17-T-350013-594	CTT	150685	150685	0-2065	1	-	-	-	-	-
0-2066	FINGER, paper: steel nickel plated; "U" shaped on one end w/one side extending forward w/end formed; approx 1 3/4" lg x 7/8" h x 1/2" wd o/a, 0.050" thk material; mts by two flat sided holes in line in sides of "U"; RH mtg, formed end has cross hatched area	Holds right side of paper to 0-1972	N17-T-350014-284	CTT	150804	150804	0-2066	1	-	-	-	-	-
0-2067	FINGER, paper: steel, nickel plated; "U" shaped on one end w/one side extending forward w/end formed; approx 1 3/4" lg x 7/8" h x 1/2" wd o/a, 0.050" thk material; mts by two flat sided holes in line in sides of "U"; LH mtg, formed end has cross hatched area	Holds left side of paper to 0-1972	N17-T-350014-296	CTT	150826	150826	0-2067	1	-	-	-	-	-
0-2068	SPRING: flat type; 0.015" thk nickel silver; approx 7/8" lg x 5/16" wd x 1/8" formed curve o/a; mts by ear on ea end	Friction spring for 0-2066 or 0-2067	N17-T-350014-283	CTT	150803	150803	0-2068	2	-	-	-	-	-

PARTS LISTS

TT-47/UG, TT-48/UG, TT-69/UG, TT-70/UG

NAVSHIPS 91393

Section 8  
O-2054—O-2068

TABLE 8-4. COMBINED PARTS AND SPARE PARTS LIST

SYMBOL DESIG.	NAME OF PART AND DESCRIPTION	FUNCTION	JAN OR NAVY TYPE DESIGNATION	STANDARD NAVY STOCK NUMBER	MANUFAC- TURERS		TELETYPE PART NO.	ALL SYMBOL DESIGNATIONS INVOLVED	SPARE PARTS				
					CODE	DESIG.			TOTAL NO. PER EQUIP.	EQUIP.		STOCK	
										BOX	QUAN.	BOX	QUAN.
0-2069	LINK: steel, nickel plated; approx 3 1/16" lg x 5/16" wd x 0.042" thk o/a; mts by body hole at ea end	Operates 0-2073		N17-T-350013-975	CTT	150270	150270	0-2069	1	-	-	-	-
0-2070	GUIDE: steel, nickel plated; irregular hook shaped w/ear on ea end of base; approx 9 3/4" lg x 1 1/8" h x 3/4" wd o/a, 0.035" thk material; mts by elongated hole in lg ear and hole in other ear	Guides paper to 0-2057		N17-T-350014-291	CTT	150818	150818	0-2070	1	-	-	-	-
0-2071	BALL: steel, nickel plated; irregular formed w/three cutouts one side, irregular shaped formed ear on ea end in line; approx 10 3/16" lg x 1 1/8" h x 5/8" wd o/a, 0.035" thk material; mts by two holes in line in formed ears	Guides and holds paper to 0-1972		N17-T-350014-113	CTT	150098	150098	0-2071	1	-	-	-	-
0-2072	SHAFT: steel; approx 9 7/8" lg x 3/32" diam o/a; mts by ends	Pivot for 0-2078		N17-T-350013-971	CTT	150265	150265	0-2072, 0-2091	2	-	-	-	-
0-2073	ARM: steel, nickel plated; curved near ctr w/rounded ends, stud riveted one end, detent shaft riveted to other ends; approx 9 5/8" lg x 5/8" h x 13/16" wd o/a, 0.035" thk material; mts by detent shaft	Releases paper through 0-2071, 0-2078 and 0-2080		N17-T-350013-976	CTT	150271	150271	0-2073	1	-	-	-	-
0-2074	BAR, cross: aluminum, plain anodize; approx 10" lg x 9/16" wd x 1/2" h o/a; mts by 2 tapped holes on ea end; slot through entire length, 16 body slots, 18 body holes	Guide for 0-2071, 0-2078 and 0-2080 and mounts 0-2072, 0-2073, 0-2075, 0-2076, and H-2080		N17-T-350014-114	CTT	150097	150097	0-2074	1	-	-	-	-
0-2075	GUIDE, paper: steel, nickel plated; irregularly formed and shaped body w/three cutouts, three fingers on ea side of cutouts, all middle fingers formed; approx 8 15/16" lg x 1" h x 1 5/16" wd o/a; mts by hole in formed finger	Clamps 0-2091 to 0-2074 and guides paper to 0-1972		N17-T-350014-112	CTT	150099	150099	0-2075	1	-	-	-	-
0-2076	BRACKET: "L" shape w/one end formed; steel, nickel plated; approx 1 1/4" lg x 9/16" h x 5/8" wd o/a, 0.035" thk material; mts by two holes in straight side of "L"	Detent for 0-2073		N17-T-350013-977	CTT	150274	150274	0-2076	1	-	-	-	-
0-2077	SPRING: helical compression type; 0.014" diam music wire; approx 1 1/4" lg x 1/8" OD x 3/32" ID o/a; approx 24 turns; close ends	Applies pressure to 0-2071		N17-T-350014-217	CTT	150534	150534	0-2077, 0-2079	8	1	2	-	-
0-2078	GUIDE, lever: steel, nickel plated; irregular shape, one arm w/ear on side, cutout near one end; approx 3/4" lg x 11/16" h x 0.065" thk o/a; mts by hole near pointed end	Releases paper through and mounts 0-2081		N17-T-350013-972	CTT	150266	150266	0-2078, 0-2080	12	-	-	-	-

CHANGE 1

0-2079	Same as 0-2077	Applies pressure to 0-2080 and 0-2078																		
0-2080	Same as 0-2078	Releases paper through and mounts 0-2082																		
0-2081	ROLLER, pressure: black bakelite; approx 1 5/8" lg x 7/16" diam o/a; mts by shank ea end	Advances paper around 0-1972	N17-T-350013-974	CTT	150269	150269	0-2081, 0-2082	6	-	-	-	-	-	-	-	-	-	-	-	-
0-2082	Same as 0-2081	Advances paper around 0-1972																		
0-2083	GUIDE: steel, nickel plated; irregular shape w/sides "U" formed and two ears; approx 3 7/8" lg x 1 1/8" h x 1/4" wd o/a, 0.042" thk material; mts by hole and elongated slot in ears; RH mtg	Guide for and positions function box mechanism through A-1312	N17-T-350013-585	CTT	150579	150579	0-2083	1	-	-	-	-	-	-	-	-	-	-	-	-
0-2084	BUSHING: steel, nickel plated; male and female; approx 5/16" across flats x #6-40 off ctr ID x 11/32" lg o/a, 1/4" diam body	Pivot for and spaces 0-2085 from left side frame	N17-T-350014-704	CTT	150961	150961	0-2084	1	-	-	-	-	-	-	-	-	-	-	-	-
0-2085	BAIL: steel, nickel plated; irregular shape, "U" shaped one end, stud riveted and welded to other end; approx 1 3/16" h x 1 3/8" lg x 1/4" wd o/a, 0.042" thk material; mts by two holes in line inside of "U"	Positioning detent for 0-1972	N17-T-350014-323	CTT	150900	150900	0-2085	1	-	-	-	-	-	-	-	-	-	-	-	-
0-2086	SPRING: torsion type; 0.040" diam music wire; approx 1 7/8" lg x 3/16" h x 3/8" wd o/a; 2 1/4" turns; left hand turns; one end curved; mts by ends	Applies tension to 0-2085	N17-T-350014-354	CTT	150969	150969	0-2086	1	-	-	-	-	-	-	-	-	-	-	-	-
0-2087	LEVER: steel, nickel plated; irregularly shaped and formed, 2 rounded projections near "L" shaped end, other end rounded; approx 3 13/16" lg x 1 7/8" h x 3/8" wd o/a, 0.065 thk material; mts by hole in bend near ctr of body	Positions 0-2016	N17-T-350014-324	CTT	150902	150902	0-2087	1	-	-	-	-	-	-	-	-	-	-	-	-
0-2088	GUIDE: steel, nickel plated; approx 1 3/4" lg x 3/8" h x 1/4" wd o/a, 0.028" thk material; mts by hole and elongated slot in body; three formed prongs on one end of body	Guide for 0-1989 and 0-1991	N17-T-350013-590	CTT	150654	150654	0-2088	1	-	-	-	-	-	-	-	-	-	-	-	-
C-2089	GUIDE: steel, nickel plated; irregular shape w/sides "U" formed and two ears; approx 3 7/8" lg x 1 1/8" h x 1/4" wd o/a, 0.042" thk material; mts by hole and elongated slot in ears; LH mtg	Guide for and positions function box mechanism through A-1314	N17-T-350013-582	CTT	150569	150569	0-2089	1	-	-	-	-	-	-	-	-	-	-	-	-
0-2090	Same as 0-1314	Pivot for and spaces 0-2087 from left side frame																		
0-2091	Same as 0-2072	Pivot for 0-2080																		
0-2092	LEVER: steel, nickel plated, one end rounded, both sides irregular shaped at center; approx 2 15/16" lg x 7/16" h x 0.050" thk o/a; mts by irregularly curved elongated slot in ctr; hole in rounded end	Positions 0-1471 through 0-1476	N17-T-350014-224	CTT	150519	150519	0-2092	1	-	-	-	-	-	-	-	-	-	-	-	-

PARTS LISTS

TT-47/UG, TT-48/UG, TT-69/UG, TT-70/UG

NAVSHIPS 91393

0-2079-O-2092

Section 8

8-181

8-182

TABLE 8-4. COMBINED PARTS AND SPARE PARTS LIST

SYMBOL DESIG.	NAME OF PART AND DESCRIPTION	FUNCTION	JAN OR NAVY TYPE DESIGNATION	STANDARD NAVY STOCK NUMBER	MANUFAC- TURERS		TELETYPE PART NO.	ALL SYMBOL DESIGNATIONS INVOLVED	TOTAL NO. PER EQUIP.	SPARE PARTS			
					CODE	DESIG.				EQUIP.		STOCK	
										BOX	QUAN.	BOX	QUAN.
0-2093	ROLLER: steel, nickel plated; c/o head and shoulder; approx 1/4" OD x 1/8" lg x 3/32" ID o/a; mts by ID	Guide for 0-2097 and spaces 0-2092 from A-1341		N17-T-350013-761	CTT	151668	151668	0-2093, 0-2103	2	1	2	-	-
0-2094	ROLLER: steel; approx 7/32" lg x 3/16" OD x 3/32" ID o/a; mts by ID	Operates 0-2092		N17-T-350014-241	CTT	151667	151667	0-2094, 0-2100	2	1	2	-	-
0-2095	SHD: steel; approx 1/2" OD x 3/32" ID x 0.010 thk o/a; mts by ID; circum has flat side	Holds 0-2096 in position on H-2119		N17-T-350013-762	CTT	151676	151676	0-2095, 0-2099	2	1	2	-	-
0-2096	Same as 0-248	Lubricates H-2119 and 0-2094											
0-2097	LINK: steel, nickel plated; irregular shape w/"L" shaped arm one end, irregular curved arm other end; approx 1/2" h x 3 1/2" lg x 7/8" wd o/a, 0.072" thk material; mts by tapped hole one end, stud other end; stud welded to body one end, hole in stud	Operates 0-2100 and 0-2094 through H-2119		N17-T-350013-984	CTT	150451	150451	0-2097	1	-	-	-	-
0-2098	Same as 0-248	Lubricates H-2119 and 0-2100											
0-2099	Same as 0-2095	Holds 0-2098 in position on H-2119											
0-2100	Same as 0-2094	Operates 0-2101											
0-2101	LEVER: steel, nickel plated; 1 straight side and 1 side irregular shaped at center, 1 end rounded; approx 2 15/16" lg x 1/2" h x 0.050" thk o/a; mts by irregularly curved elongated slot in ctr, hole in rounded end	Positions 0-1471 through 0-1476		N17-T-350014-166	CTT	151677	151677	0-2101	1	-	-	-	-
0-2102	Same as 0-1487	Lubricates 0-2097 and 0-2106											
0-2103	Same as 0-2093	Guide for 0-2097 and spaces 0-2101 from A-1341											
0-2104	BRACKET: irregular shape; steel, nickel plated; approx 4 1/4" lg x 1" wd 7/8" h o/a, 0.050" thk material; mts by 3 body holes and 1 hole in ear; 4 formed arms, one at end with 2 rectangular cutouts, 1 rounded with body hole, 1 "L" shaped w/2 tapped holes and 1 opposite w/tapped hole, 1 elongated and 3 curved cutouts in body, 7 body slots, 4 body holes and 1 tapped hole in body, 3 tapped holes in ears have welded disks	Guide for 0-1471 through 0-1476, 0-2092 and 0-2101 and mounts 0-2120, A-1340, 0-2108 and 0-2114		N17-T-350013-880	CTT	150525	150525	0-2104	1	-	-	-	-
0-2105	SHAFT: steel, nickel plated; 1 7/32" lg x 1/8" diam; mts by #4-40 thd on one end; slot on head end	Stop for 0-2123 through 0-2128		N17-T-350014-540	CTT	150481	150481	0-2105	1	-	-	-	-

CHANGE 1

8 Section  
O-2093—O-2105

TT-47/UG, TT-48/UG, TT-69/UG, TT-70/UG

NAVSHIPS 91393

PARTS LISTS

CHANGE 1

0-2106	ARM: steel, nickel plated; "U" shaped at one end w/one side of "U" curved over and round at other end; approx 1 1/4" lg x 11/16" h x 9/32" wd o/a, 0.065" thk material; mts by 2 holes in line in sides of "U"; slots through bottom of "U" to mtg holes, body hole in round end	Operates 0-2097	N17-T-350014-689	CTT	150447	150447	0-2106	1	-	-	-	-
0-2107	BEARING, sleeve; aluminum, plain anodize; approx 2 3/4" lg x 1 11/16" wd x 1 1/16" h o/a, 9/32" ID w/bushing pressed in ea end, arm w/tapped hole near 1 end, shoulder w/tapped hole on ea side near ctr	Bearing sleeve for 0-2115	N17-T-350014-691	CTT	150452	150452	0-2107	1	-	-	-	-
0-2108	SHAFT: steel, nickel plated; c/o hex head and body; approx 7/8" lg x 5/16" across flats; mts by tapped hole in ea end; 7 slots in body	Guide for 0-2109 through 0-2113	N17-T-350014-701	CTT	150465	150465	0-2108	1	-	-	-	-
0-2109	ARM: steel, nickel plated; irregular shape, 2 arms one end w/slot between, slot on side near other end; approx 1 9/32" lg x 11/16" h x 0.042" thk o/a; mts by slot in rounded end	Operates 0-2123	N17-T-350014-690	CTT	150450	150450	0-2109 through 0-2113	5	1	2	-	-
0-2110	Same as 0-2109	Operates 0-2124										
0-2111	Same as 0-2109	Operates 0-2128										
0-2112	Same as 0-2109	Operates 0-2126										
0-2113	Same as 0-2109	Operates 0-2127										
0-2114	BRACKET: irregular shape; steel, nickel plated finish; 2 11/32" lg x 1 5/8" wd x 1 5/16" h, 0.050" thk material; mts by body hole, one body hole on extended ear one tapped hole; 7 slots 5/32" dp, two 5/32" diam holes, one 1/8" diam hole	Guide for 0-2109 through 0-2113	N17-T-350013-920	CTT	150524	150524	0-2114	1	-	-	-	-
0-2115	SHAFT: stainless steel; "L" shape; approx 3 5/16" lg x 1 1/8" h x 1/2" wd o/a; mts by tapped hole; link welded to shaft	Operates 0-2106	N17-T-350014-692	CTT	150453	150453	0-2115	1	1	1	-	-
0-2116	Same as 0-295	Lubricates H-2154 and 0-1768										
0-2117	WICK: hard white felt; approx 1 1/4" lg x 13/16" h x 3/32" thk o/a	Lubricates 0-1510 to 0-1513 and 0-1515 to 0-1520	N17-T-350014-589	CTT	151636	151636	0-2117	1	1	1	-	-
0-2118	LINK: steel, nickel plated; straight sides, both ends rounded; approx 11/16" lg x 9/32" wd x 0.072" thk o/a; mts by body hole and tapped hole	Mounts H-2157 to 0-2114	N17-T-350014-537	CTT	150472	150472	0-2118	1	-	-	-	-
0-2120	GUIDE: steel, nickel plated; approx 7/8" lg x 11/32" OD x 1/8" ID o/a; mts by ID off center; 7 slots, two holes on angle near one end	Guide for 0-2123 through 0-2128	N17-T-350014-688	CTT	150446	150446	0-2120	1	-	-	-	-

PARTS LISTS

TT-47/UG, TT-48/UG, TT-69/UG, TT-70/UG

NAVSHIPS 91393

Section 8  
0-2106-0-2120

8-183



TABLE 8-4. COMBINED PARTS AND SPARE PARTS LIST

SYMBOL DESIG.	NAME OF PART AND DESCRIPTION	FUNCTION	JAN OR NAVY TYPE DESIGNATION	STANDARD NAVY STOCK NUMBER	MANUFAC- TURERS		TELETYPE PART NO.	ALL SYMBOL DESIGNATIONS INVOLVED	TOTAL NO. PER EQUIP.	SPARE PARTS			
					CODE	DESIG.				EQUIP.		STOCK	
										BOX	QUAN.	BOX	QUAN.
0-2121	SPRING: helical extension type; 0.009" diam music wire; approx 13/16" lg x 3/32" OD x 1/16" ID o/a; approx 70 turns; hook term ea end; mts by terms	Applies tension to 0-2125		N17-T-350014-201	CTT	150563	150563	0-2121	1	1	1	-	-
0-2122	SPRING: helical extension type; 0.009" diam music wire; approx 3/8" lg x 3/32" OD x 1/16" ID o/a; approx 25 turns; hook terminal ea end; mts by term	Applies tension to 0-2123, 0-2124, 0-2126, 0-2127 or 0-2128		N17-T-350013-980	CTT	150507	150507	0-2122	5	1	1	-	-
0-2123	LEVER: steel, nickel plated; irregular shape, two arms bent in at end forming cutout on one end, rounded cutout other end w/lg arm on one side; approx 2 1/8" lg x 5/8" wd x 0.042" thk o/a; mts by rounded cutout; numeral "1" stamped below mtg cutout; csk hole below numeral	Operates 0-1472 and 0-2125		N17-T-350013-874	CTT	150509	150509	0-2123	1	-	-	-	-
0-2124	LEVER: steel, nickel plated; irregular shape, 2 arms bent in at end forming cutout on one end, rounded cutout other end w/lg arm one side; approx 2" lg x 5/8" wd x 0.042" thk o/a; mts by rounded cutout; numeral "2" stamped below mtg cutout; csk hole below numeral	Operates 0-1474 and 0-2125		N17-T-350013-875	CTT	150510	150510	0-2124	1	-	-	-	-
0-2125	LEVER: steel, nickel plated; irregular shape, 2 arms bent in at end forming cutout on one end, rounded cutout other end w/arm on one side; approx 1 15/16" lg x 9/16" wd x 0.042" thk o/a; mts by rounded cutout; numeral "3" stamped below mtg cutout; csk hole below numeral	Operates 0-1476		N17-T-350013-876	CTT	150511	150511	0-2125	1	-	-	-	-
0-2126	LEVER: steel, nickel plated; irregular shape, 2 arms bent in at end forming cutout on one end, rounded cutout other end w/arm on one side; approx 2 1/4" lg x 5/8" wd x 0.042" thk o/a; mts by rounded cutout; numeral "4" stamped below mtg cutout; csk hole below numeral	Operates 0-1471		N17-T-350013-877	CTT	150512	150512	0-2126	1	-	-	-	-
0-2127	LEVER: steel, nickel plated; irregular shape, 2 arms bent in at ends forming cutout on one end, rounded cutout other end w/arm one side; approx 2 1/16" lg x 5/8" wd x 0.042" thk o/a; mts by rounded cutout; numeral "5" stamped below mtg cutout; csk hole below numeral	Operates 0-1473		N17-T-350013-878	CTT	150513	150513	0-2127	1	-	-	-	-

8-184

CHANGE 1

## PARTS LISTS

NAVSHIPS 91393

TT-47/UG, TT-48/UG, TT-69/UG, TT-70/UG

Section 8  
O-2128-R-1101

0-2128	LEVER: steel, nickel plated; irregular shape, one end has two arms curved in at ends forming cutout w/formed ear on side of one arm, other end has curved cutout and lg arm on side; approx 1 3/4" lg x 1 1/16" h x 1/4" wd o/a, material 0.042" tk; mts by curved cutout; letter "C" stamped below curved cutout; csk hole below stamped letter	Operates 0-1475	N17-T-350013-879	CTT	150515	150515	0-2128	1	-	-	-	-	-
0-2129	BEARING, sleeve: screw steel; approx 1 1/32" lg x 5/16" OD x 1/8" ID o/a, 0.055" lg x 3/16" diam shank ea end of body	Spaces 0-2092 and 0-2101	N17-T-350013-919	CTT	150473	150473	0-2129	1	-	-	-	-	-
0-2130	WICK: lubricating wick; felt, w/o spring; approx 13/16" lg x 3/16" diam o/a	Lubricates 0-1596	N17-W-228001-101	CG	1787309	73520	0-2130	1	-	-	-	-	-
0-2131	FOLLOWER BAIL: steel, nickel plated; irregularly curved follower, w/ear on rounded end, held to irregular "U" shaped bail, w/round ear on one side, by 2 screws, lock washers and washers; approx 2 1/16" lg x 1 3/4" h x 15/16" wd o/a; mts by 2 holes in line in sides of "U"; hub welded to ear, 2 body holes and 2 csk holes in bail, two hubs welded to follower; supplied in assembled form only	Operates 0-1490	N17-T-350014-923	CTT	151793	151793	0-2131	1	1	1	-	-	-
0-2132	Same as 0-1634	Lubricates 0-1754											
0-2133	SPRING: helical compression type; 0.014" diam music wire; approx 7/32" lg x 5/32" OD o/a; approx 6 turns; straight ends	Applies pressure to 0-2134	N17-T-350004-603	CTT	110872	110872	0-2133	1	-	-	-	-	-
0-2134	Same as 0-1349	Ball valve for 0-1609											
P-601	PLUG, machine thread: steel, nickel plated; approx 5/32" lg x 13/32" diam o/a; mts by 3/32" lg 3/8" x 32' threaded shank; drive slot across head	Plug for A-612		CTT	152035	152035	P-601	1	-	-	-	-	-
P-1101	CONNECTOR, plug: 14 round female contacts; straight; approx 2 11/32" h x 1 7/8" lg x 17/32" wd o/a; rectangular shaped aluminum body; molded melamine insert; includes cable clamp, two guide pins on face	Termination for and connects W-1101 to J-101	N17-C-71301-4688	WING ELEC INC.	ESTER RONICS	151800	P-1101	1	-	-	-	-	-
P-1102	CONNECTOR, plug: 14 round female contacts; straight; approx 2 11/32" lg x 1 7/8" h x 17/32" wd o/a; rectangular shaped aluminum body; molded melamine insert; includes cable clamp, two guide pins on face	Termination for and connects W-1101 to J-1301	N17-C-71302-4301	WING ELEC INC.	ESTER RONICS	151806	P-1102	1	-	-	-	-	-
R-603	RESISTOR, fixed: Ww; 250 ohms; 40 w at 300° C max continuous oper temp; approx 2" lg x 1 3/16" wd x 1/2" h o/a; vitreous enamel coating; 2 radial tab term; mts by 2 slots through lg of body	Offers resistance to PD-18/U		CTT	152054	152054	R-603	1	-	-	-	-	-
R-1101	RESISTOR, fixed: wire wound; 250 ohms +10%; 5 watts; 340° C; approx 1" lg x 5/16" OD x 3/16" ID; vitreous enamel, humidity resistant; 2 tabs 7/16" lg x 3/16" wd w/two #18 wire leads 1 1/2" lg	Line balancing resistance for use in 20 mil operation	N16-R-70527-6664	CAO	SF-225-VITROH	151439	R-1101	1	-	-	-	-	-

CHANGE 1

8-185

TABLE 8-4. COMBINED PARTS AND SPARE PARTS LIST

PARTS										SPARE PARTS			
SYMBOL DESIG.	NAME OF PART AND DESCRIPTION	FUNCTION	JAN OR NAVY TYPE DESIGNATION	STANDARD NAVY STOCK NUMBER	MANUFACTURERS		TELETYPE PART NO.	ALL SYMBOL DESIGNATIONS INVOLVED	TOTAL NO. PER EQUIP.	EQUIP.		STOCK	
					CODE	DESIG.				BOX	QUAN.	BOX	QUAN.
S-101	SWITCH, sensitive: SPMT; rated 15 amp 115 v ac; bakelite case; approx 1 3/4" lg x 1 1/8" wd x 5/16" thk o/a; actuation by stainless steel plunger; 6 oz operating pressure; actuating mechanism travel differential 0.075"; pretravel 1/32" max; overtravel 0.025" min; momentary action; beryllium copper terminals; mts by four body holes	Operates PD-17/U or PD-18/U		N17-S-69146-1843	CATK	IND12 AXX	151329	S-101, S-102	2	-	-	-	-
S-102	Same as S-101	Operates "end of line" indicator light											
S-501	SWITCH, thermostatic: SPST; operated as current overload device; 11 amps; bakelite; approx 1 1/2" lg x 5/8" wd x 7/8" h o/a; wire lead term; mts by cutout ea end	Current overload switch, prevents overheating		N17-T-350013-902	CG	112A-600BA-P7	122249	S-501	1	-	-	-	-
S-502	SWITCH, motor: SPST; 9 amps to start, 2 amps to run; approx 4 3/4" lg x 3 5/8" wd x 3/4" h o/a; mts by three body holes; bakelite case thermostatic switch mtd on outside	Disconnects auxiliary winding at approx 2700 rpm		N17-T-350013-809	CG	111B-910AA-G1	122254	S-502	1	-	-	-	-
S-503	SWITCH, centrifugal: 9 amps; approx 2 3/8" lg x 2" wd x 1 1/8" h o/a; mts by elongated hole in ear on ea end	Operates S-502		N17-T-350013-903	CG	115A-820AB-G1	122248	S-503	1	-	-	-	-
SYMBOL DESIGNATION S-751 USED ON CY-870/UG AND CY-871/UG CABINETS													
S-751	SWITCH, toggle: SPST	Switch for E-751 and E-752	ST13A	N17-T-70777-8601	CHH	82301BS	118734	S-751	1	-	-	-	-
S-1102	SWITCH, toggle: DPDT; 3 position (center position "OFF"); 4 amps, 125 V DC, 20 amps, 24 V DC; bakelite body; approx 1 5/16" lg x 3/4" wd x 25/32" h o/a body dimensions; 23/32" lg bat type handle; locking action; solder lug terminal; single hole mtg bushing 15/32" - 32 thd x 15/32" lg	Power switch for PD-17/U or PD-18/U		N17-S-73877-4921	CAE	#8821	108409	S-1102	1	-	-	-	-
S-1103	SWITCH, toggle: DPDT	Copy light switch	ST23N	N17-S-74139-4794	CHH	82305 BS	118659	S-1103	1	1	1	-	-
S-1104	SWITCH, sensitive: SPDT, 2 position; 125 v AC - 60 cycle - 10 amp noninductive load; phenolic body; approx 2 1/8" lg x 9/16" wd x 7/16" h o/a; snap action actuated; 3 to 8 ounce operating pressure; 1/32" to 1/16" overtravel; 1 cont normally closed; solder lug terms; mts by hole at ea end	Stops and applies shunt to E-1108A and E-1108B		N17-S-69452-7985	FIRST TRIAL	INDUS- CORP. #SK-3 (double throw)	151414	S-1104, S-1105	1	-	-	-	-
S-1105	Same as S-1104	Stops and operates PD-17/U or PD-18/U											

## SYMBOL DESIGNATION T-751 USED ON CY-870/UG AND CY-871/UG CABINETS

T-751	TRANSFORMER, power: filament type; 117 v, 50-60 cyc, single ph; one output winding, sec'd 6.3 v, 6 amp, ctr tapped; 1600 v insulation; varnish impregnated; metal cover one side; approx 5 1/16" lg x 2 29/32" wd x 2 5/8" h o/a, incl bracket and cover; four CTT #151626 terms at end of 15" lg four conductor cable; mts by three 7/32" diam holes in bracket	Supplies power to E-751 and E-752	N17-T-350014-906	CTT	151984	151984	T-751	1	-	-	-	-
TB-101	BOARD, terminal: 4 nickel plated steel terminals; terminals 3/8" between centers; w/barriers; black bakelite; approx 2 5/16" lg x 1/2" wd x 1/2" h o/a; mtg hole each end	Terminal board for W-101	N17-T-350013-729	CTT	151415	151415	TB-101, TB-1103	2	-	-	-	-

## SYMBOL DESIGNATIONS TB-751 TO TB-753 INCL USED ON CY870/UG AND CY-871/UG CABINETS

TB-751	BOARD, terminal: general purpose; 10 brass nickel pl #6-32 thd screw term; term 7/16" between centers w/barriers; molded phenolic board; approx 5 1/8" lg x 1 1/8" w x 1/2" thk o/a; four 3/16" diam mtg holes on 27/64" x 4 13/16" mtg/c	Terminal board for W-1101	# N17-B-77937-4697	CJC	10-141	118759	TB-751, TB-752, TB-753	3	1	1	-	-
TB-752	Same as TB-751	Terminal board for W-1101 and XI-751										
TB-753	Same as TB-751	Terminal board for W-1101										
TB-1101	BOARD, terminal: nine nickel plated steel screw terminals; terminals 3/8" between centers, w/barriers; black bakelite; approx 4 3/16" lg x 1/2" wd x 1/2" h o/a; 5/16" mtg hole each end	Terminal board for W-1101	N17-T-350013-726	CTT	151411	151411	TB-1101, TB-1102	2	-	-	-	-
TB-1102	Same as TB-1101	Terminal board for W-1101										
TB-1103	Same as TB-1101	Terminal board for W-1101										
W-101	CABLE ASSEMBLY, special purpose: lacquered cotton braid covering; 10 conductors, #18 and #22 AWG stranded copper wire; lock stitch covered w/vinylite tape; approx 11" lg o/a; color coded; 16 breakouts w/tinned ends, two breakouts w/Teletype 151626 terminals soldered on ends, two breakouts folded and taped back on one end	Connects J-101 with TB-101, S-101, S-102 and Z-101	N17-T-350014-864	CTT	151348	151348	W-101	1	-	-	-	-
W-501	CABLE ASSEMBLY, special purpose: lacquered cotton braid covering; 3 conductors, #18 AWG stranded copper wire; bound w/#6 lacing twine; approx 12" lg o/a; 2 conductors w/CTT 151626 terminals soldered to one end, 4 conductors skinned and tinned other end, vinyl plastic flexible tubing in ctr, tied at ends w/#6 lacing twine	Connects PD-17A/U with TB-101		CTT	151927	151927	W-501	1	-	-	-	-
W-602	CABLE ASSEMBLY, special purpose: lacquered cotton braid covering; 2 conductors, #14 AWG stranded copper; covered w/12" lg tubing and tied w/#6 lacing twine; approx 14 3/4" lg o/a; color coded; both conductors tinned one end, CTT #151626 terminals soldered to other end	Connects PD-18/U with Z-601		CTT	152059	152059	W-602	1	-	-	-	-

# TB-751 to TB-753 used on CY-870/UG and CY-871/UG

TABLE 8-4. COMBINED PARTS AND SPARE PARTS LIST

SYMBOL DESIG.	NAME OF PART AND DESCRIPTION	FUNCTION	JAN OR NAVY TYPE DESIGNATION	STANDARD NAVY STOCK NUMBER	MANUFAC- TURERS		TELETYPE PART NO.	ALL SYMBOL DESIGNATIONS INVOLVED	SPARE PARTS				
					CODE	DESIG.			TOTAL NO. PER EQUIP.	EQUIP.		STOCK	
										BOX	QUAN.	BOX	QUAN.
SYMBOL DESIGNATION W-751 USED ON CY-870/UG AND CY-871/UG CABINETS													
W-751	CABLE ASSEMBLY, special purpose: lacquered cotton braid covering; 2 conductors, #18 AWG copper stranded wire; laced w/#6 lacing twine; approx 34 1/4" lg o/a; color coded; two CTT #151626 terms one end, one breakout w/CHH #82301BS switch, two CAYZ #12-71 sockets spliced to cable	Connects S-751, XE-751 and XE-752 with TB-752		# N17-T-350014-897	CTT	151981	151981	W-751	1	-	-	-	-
W-1101	CABLE ASSEMBLY, special purpose: lacquered cotton braided insulation; one 45 conductor main power cable w/#18 and 22 AWG stranded copper wire, two 14 conductor (power supply to MA-1115/UG and MA-1114/UG) cables w/#18 and #22 AWG stranded copper wire spliced to main cable in two separate places; main power cable lock stitch, covered w/vinylite tape, two power supply cables rubber covered; approx 52" lg o/a; color coded; leads, irregularly spaced, skinned, twisted and tinned, CTT #151626 terminal soldered to 40 leads, CTT #107398 terminal soldered to 2 leads, ea power supply cable clamped to SB-154/UG by a CTT #115508 washer and a CHU #112 clamp, Winchester Electronics #MRE12-2S, MRE12-2H (top opening) connector on end of one power supply cable; #MRE12-2S, MRE12-2H (end opening) connector on end of other power supply cable	Main power cable, connects SB-154/UG with MX-1114/UG, MX-1115/UG, PD-17/U or PD-18/U and CY-870/UG or CY-871/UG		N17-T-350014-850	CTT	151433	151433	W-1101	1	-	-	-	-
W-1102	CABLE ASSEMBLY, special purpose: lacquered cotton braid covering; 12 conductors, #18 and #20 AWG copper stranded wire; lock stitch covered w/vinylite tape; approx 10" lg o/a; color coded; c/o short body w/four arms w/24 leads irregularly spaced, eight conductors have Teletype #151626 terminals soldered on, remaining conductors skinned, twisted and tinned	Connects W-1101 with motor control mechanism through TB-1102		N17-T-350013-898	CTT	151417	151417	W-1102	1	-	-	-	-
W-1301	CABLE ASSEMBLY, special purpose: lacquered, cotton braid covering; two conductors, #22 AWG stranded copper wire; lock stitched, covered w/vinylite tape, heat seal; approx 13 1/2" lg; color coded; both conductors tinned both ends	Connects E-1301 and E-1302, with J-1301		N17-T-350014-754	CTT	150971	150971	W-1301	1	-	-	-	-

8-188

CHANGE 1

CHANGE 1

8-189

W-1302	CABLE ASSEMBLY, special purpose; lacquered cotton braid covering; 4 conductors #22 AWG stranded copper wire; lock stitched, covered w/vinylite tape, heat seal; approx 10" lg o/a; color coded; four conductors one end w/Teletype 151626 terminals soldered on ends, other end tinned	Connects E-1304 and E-1305 with J-1301	N17-T-350014-846	CTT	150972	150972	W-1302	1	-	-	-	-
W-1303	WIRE ROPE: steel 3/64" OD; braided; approx 60 3/4" lg o/a; eye hook term at ea end	Pulls printing carriage mechanism through O-1312 and O-1313 and pulls type box mechanism through O-1672	N17-T-350014-838	CTT	150712	150712	W-1303	1	1	1	-	-
W-1304	WIRE ROPE: steel 3/64" OD; braided; approx 20 13/16" lg o/a; eye hook terminal at ea end	Tension cable between O-1687 and O-1690	N17-T-350014-835	CTT	150225	150225	W-1304	1	1	2	-	-
SYMBOL DESIGNATIONS XE-751 AND XE-752 USED ON CY-870/UG AND CY-871/UG CABINET												
XE-751	LAMPHOLDER: candelabra bayonet type; steel shell body; 110 V; approx 15/16" h x 5/8" wd x 1" lg o/a, 5/8" diam socket; mts by elongated slot in bracket; mtg bracket located parallel to and beside socket; two wire leads 3 3/4" lg	Socket for E-751	# N17-L-51706-8201	CAYZ	12-71	151540	XE-751, XE-752	2	-	-	-	-
XE-752	Same as XE-751	Socket for E-752										
XF-1102	HOLDER, fuse: extractor post type; for single 1/4" diam x 1 1/4" lg cartridge fuse; bakelite body; 15 amp; 2 1/8" lg x 5/8" diam o/a; 1/2" diam mtg hole; 2 solder lug term	Fuse holder for F-1101	N17-F-74267-5075	CFA	HXP	116783	XF-1101, XF-1102	2	-	-	-	-
XF-1101	Same as XF-1101	Fuse holder for F-1102										
SYMBOL DESIGNATION XI-751 USED ON CY-870/UG AND CY-871/UG CABINETS												
XI-751	LAMPHOLDER: candelabra bayonet; steel shell body; 110 v; approx 15/16" h x 5/8" wd x 1" lg o/a, 5/8" diam socket; mts by elongated slot in bracket; mtg bracket located parallel to and beside socket; CAYZ #12-71 socket w/two 3 3/4" lg conductors spliced to approx 27" lg two conductor cable w/two CTF #151626 terminals soldered on end	Holder for and connects I-751 to TB-752	# N17-T-350014-770	CTT	151535	151535	XI-751	1	-	-	-	-
Z-101	SUPPRESSOR, electrical noise: choke coil and capacitor; approx 3 7/8" lg x 1 1/2" wd x 1/8" h o/a dim of case incl capacitors; 1 1/4 amp, 600 v DC; rectangular metal case; mts by 2 #6-40 tapped holes 2 3/8" c to c in bracket soldered to case; 3 solder lug terms inside case, 2 conductor cables, enclosed in copper tubing, irregularly formed, soldered together 5 places and soldered to one end of case near figures "1" and "2" stamped in case, cable 7 5/8" lg o/a, 2 Erie #362 feed through capacitors, covered w/bakelite caps, on same end of case as cable	Signal line radio interference suppressor	N17-T-350014-911	CTT	151369	151369	Z-101	1	-	-	-	-
Z-601	SUPPRESSOR, electrical noise: resistor and capacitor; approx 2 3/16" lg x 2 3/16" wd, incl term, x 1 1/4" h o/a; 1 1/4 amp, 150 v AC; rectangular metal case; 5 solder lug term; hermetically sealed	PD-18/U radio interference suppressor		CLE	1152	152055	Z-601	1	-	-	-	-
								# W-751, XE-751, XE-752 and XI-751 used on CY-870/UG and CY-871/UG				

PARTS LISTS

TT-47/UG, TT-48/UG, TT-69/UG, TT-70/UG

NAVSHIPS 91393

W-1302-Z-601

Section 8

TABLE 8-4. COMBINED PARTS AND SPARE PARTS LIST

SYMBOL DESIG.	NAME OF PART AND DESCRIPTION	FUNCTION	JAN OR NAVY TYPE DESIGNATION	PARTS		TELETYPE PART NO.	ALL SYMBOL DESIGNATIONS INVOLVED	SPARE PARTS										
				STANDARD NAVY STOCK NUMBER	MANUFAC- TURERS			TOTAL NO. PER EQUIP.	EQUIP.		STOCK							
					CODE				DESIG.	BOX	QUAN.	BOX	QUAN.					
				SYMBOL DESIGNATIONS Z-751 AND Z-752 USED ON														
Z-751	SUPPRESSOR, electrical noise; capacitor and coil; approx 5 3/4" lg x 2 1/4" wd x 1 5/8" h o/a incl mtg brackets; 2.5 amp, 150 v AC; rectangular metal case; two 3/16" diam mtg holes in mtg brackets, 5 1/4" c to c; two screw terms; 7/8" diam hole in bottom of case, two conductor cable 36" lg w/CTT #151626 terms on one end, "ELECTRICAL NOISE SUPPRESSOR 2.5 AMP 150 V AC 1473 INDUSTRIAL COND CORP CHICAGO, U.S.A." printed on top of case	Power, radio interference suppressor		# N17-T-350014-905	CTT	151989	151989	Z-751, Z-752	2	-	-	-	-	-	-	-	-	-
Z-752	Same as Z-751	Line, radio interference suppressor																

# Z-751 and Z-752 used on CY-870/UG and CY-871/UG

8-190

CHANGE 1





TABLE 8-5. CROSS REFERENCE PARTS LISTS

JAN DESIGNATION	KEY SYMBOL	FEDERAL STOCK NUMBER	KEY SYMBOL	FEDERAL STOCK NUMBER	KEY SYMBOL	FEDERAL STOCK NUMBER	KEY SYMBOL
ST23N	S-1103	N17-T-350005-763	H-387	N17-T-350013-388	H-147	N17-T-350013-736	E-1102
Navy Type Number	Key Symbol	N17-T-350005-764	H-1167	N17-T-350013-529	O-235	N17-T-350013-737	H-1146
Army-Navy Type Number	Key Symbol	N17-T-350005-771	H-1768	N17-T-350013-579	O-2034	N17-T-350013-738	O-1920
Federal Stock Number	Key Symbol	N17-T-350005-776	H-125	N17-T-350013-580	O-1419	N17-T-350013-739	O-1918
N16-C-19925-1001	C-501	N17-T-350005-817	O-2020	N17-T-350013-581	O-1418	N17-T-350013-740	H-1601
N16-C-47329-8532	C-602	N17-T-350005-822	O-288	N17-T-350013-582	O-2089	N17-T-350013-741	O-1477
N16-R-70527-6664	R-1101	N17-T-350005-830	O-2040	N17-T-350013-583	A-1314	N17-T-350013-742	O-1644
N17-B-77937-4697	TB-751	N17-T-350005-966	H-650	N17-T-350013-584	E-1302	N17-T-350013-743	O-1643
N17-B-86234-3601	E-607	N17-T-350006-300	H-117	N17-T-350013-585	O-2083	N17-T-350013-744	H-1312
N17-C-71301-4688	P-1101	N17-T-350006-301	O-220	N17-T-350013-586	A-1312	N17-T-350013-745	O-1314
N17-C-71302-4301	P-1102	N17-T-350006-313	O-1306	N17-T-350013-587	O-1989	N17-T-350013-746	O-1317
N17-C-73137-1875	J-1403	N17-T-350006-330	O-282	N17-T-350013-588	E-1301	N17-T-350013-747	H-1326
N17-C-73588-3386	J-101	N17-T-350006-350	O-240	N17-T-350013-589	A-1316	N17-T-350013-748	O-1684
N17-C-780767-838	H-773	N17-T-350006-353	O-2047	N17-T-350013-590	O-2088	N17-T-350013-749	O-1481
N17-C-781108-951	H-1106	N17-T-350006-362	O-214	N17-T-350013-591	O-1614	N17-T-350013-750	O-1560
N17-C-781534-216	H-1105	N17-T-350006-393	O-148	N17-T-350013-592	A-1323	N17-T-350013-751	O-1960
N17-C-781697-410	H-664	N17-T-350006-358	O-1107	N17-T-350013-594	O-2065	N17-T-350013-752	H-200
N17-C-945001-855	A-501	N17-T-350006-397	O-2019	N17-T-350013-595	O-1420	N17-T-350013-753	H-1150
N17-E-39047-4401	O-504	N17-T-350006-401	O-2045	N17-T-350013-596	O-1574	N17-T-350013-754	H-516
N17-E-39047-4501	O-615	N17-T-350006-406	O-1953	N17-T-350013-597	O-1953	N17-T-350013-755	H-1888
N17-E-39047-6101	O-503	N17-T-350006-407	O-1648	N17-T-350013-598	O-1648	N17-T-350013-756	H-151
N17-E-39048-1001	O-610	N17-T-350006-446	O-1380	N17-T-350013-599	O-1664	N17-T-350013-757	H-1772
N17-F-14327-30	F-1101	N17-T-350006-455	O-761	N17-T-350013-600	O-1680	N17-T-350013-758	H-1771
N17-F-74267-5075	XF-1101	N17-T-350006-478	O-1600	N17-T-350013-601	O-1569	N17-T-350013-759	H-268
N17-H-71773-1911	H-682	N17-T-350006-500	O-1528	N17-T-350013-602	O-1581	N17-T-350013-760	A-1328
N17-L-5280	E-751	N17-T-350006-523	O-284	N17-T-350013-603	E-756	N17-T-350013-761	O-2093
N17-L-51706-8201	XE-751	N17-T-350006-529	O-1588	N17-T-350013-604	E-1304	N17-T-350013-762	O-2095
N17-M-75164-2706	A-753	N17-T-350006-540	O-2041	N17-T-350013-605	E-1108A	N17-T-350013-763	E-1107
N17-M-75297-6751	A-701	N17-T-350006-542	O-2027	N17-T-350013-606	O-1987	N17-T-350013-764	O-1109
N17-M-75322-4551	A-754	N17-T-350006-578	O-1355	N17-T-350013-607	O-2028	N17-T-350013-789	H-220
N17-R-64362-8037	K-1101	N17-T-350006-703	H-821	N17-T-350013-608	O-1949	N17-T-350013-791	O-196
N17-S-46657-8041	O-1573	N17-T-350006-711	O-1379	N17-T-350013-614	H-385	N17-T-350013-792	H-148
N17-S-46710-9634	O-771	N17-T-350006-753	H-757	N17-T-350013-616	O-1301	N17-T-350013-793	H-1130
N17-S-46712-8201	O-1924	N17-T-350006-837	O-1650	N17-T-350013-617	O-1963	N17-T-350013-794	O-103
N17-S-46718-7051	O-311	N17-T-350006-840	H-768	N17-T-350013-618	H-787	N17-T-350013-795	O-1370
N17-S-46726-8131	O-289	N17-T-350006-864	O-1488	N17-T-350013-619	H-1466	N17-T-350013-797	H-262
N17-S-46759-6345	O-1514	N17-T-350006-892	H-1332	N17-T-350013-620	O-1538	N17-T-350013-798	H-264
N17-S-46761-6791	O-299	N17-T-350006-899	I-752	N17-T-350013-621	H-285	N17-T-350013-799	H-322
N17-S-46762-1032	O-277	N17-T-350006-929	H-513	N17-T-350013-622	O-256	N17-T-350013-800	H-199
N17-S-46846-1676	O-1651	N17-T-350007-458	O-132	N17-T-350013-624	H-255	N17-T-350013-801	H-1543
N17-S-69146-1843	S-101	N17-T-350007-565	O-1391	N17-T-350013-625	O-1701	N17-T-350013-802	H-666
N17-S-69452-7985	S-1104	N17-T-350007-582	H-817	N17-T-350013-626	O-248	N17-T-350013-803	O-609
N17-S-73877-4921	S-1102	N17-T-350007-593	O-502	N17-T-350013-627	O-296	N17-T-350013-804	H-502
		N17-T-350007-747	H-1129	N17-T-350013-628	O-1634	N17-T-350013-805	H-665
		N17-T-350007-862	H-767	N17-T-350013-629	O-1326	N17-T-350013-806	C-601
		N17-T-350008-103	O-1683	N17-T-350013-630	O-1670	N17-T-350013-807	A-502
		N17-T-350008-717	O-1304	N17-T-350013-676	O-295	N17-T-350013-808	O-501
		N17-T-350008-718	H-1168	N17-T-350013-677	H-228	N17-T-350013-809	S-502
		N17-T-350009-218	O-1744	N17-T-350013-678	H-241	N17-T-350013-810	O-1745

N17-S-74139-4794  
 N17-T-350001-128  
 N17-T-350001-130  
 N17-T-350001-159  
 N17-T-350001-164  
 N17-T-350001-165  
 N17-T-350001-166  
 N17-T-350001-195  
 N17-T-350001-296  
 N17-T-350001-310  
 N17-T-350001-357  
 N17-T-350001-418  
 N17-T-350001-535  
 N17-T-350001-597  
 N17-T-350001-795  
 N17-T-350001-800  
 N17-T-350001-890  
 N17-T-350001-968  
 N17-T-350002-228  
 N17-T-350002-267  
 N17-T-350002-349  
 N17-T-350002-671  
 N17-T-350002-774  
 N17-T-350003-233  
 N17-T-350003-322  
 N17-T-350003-370  
 N17-T-350003-590  
 N17-T-350003-956  
 N17-T-350004-117  
 N17-T-350004-448  
 N17-T-350004-603  
 N17-T-350004-640  
 N17-T-350004-694  
 N17-T-350004-695  
 N17-T-350004-754  
 N17-T-350004-784  
 N17-T-350004-785  
 N17-T-350004-826  
 N17-T-350005-150  
 N17-T-350005-401  
 N17-T-350005-442  
 N17-T-350005-509  
 N17-T-350005-532  
 N17-T-350005-535  
 N17-T-350005-561  
 N17-T-350005-565  
 N17-T-350005-622  
 N17-T-350005-722  
 N17-T-350005-725  
 N17-T-350005-731  
 N17-T-350005-735  
 N17-T-350005-740  
 N17-T-350005-753  
 N17-T-350005-754

S-1103  
 H-663  
 H-146  
 H-760  
 H-796  
 H-771  
 H-667  
 O-1743  
 H-2018  
 H-1597  
 H-1734  
 O-133  
 O-1358  
 H-797  
 H-1739  
 O-1708  
 O-1686  
 O-1539  
 H-284  
 H-2079  
 O-1486  
 O-1673  
 O-1546  
 H-282  
 O-255  
 H-204  
 O-1114  
 O-287  
 H-376  
 H-310  
 O-2133  
 H-1134  
 H-188  
 H-324  
 O-127  
 O-1758  
 O-1841  
 H-781  
 H-1107  
 O-1850  
 H-1576  
 H-142  
 H-1306  
 H-120  
 H-118  
 H-515  
 H-190  
 H-259  
 H-400  
 H-1451  
 H-703  
 H-290  
 H-772  
 H-531

N17-T-350009-301  
 N17-T-350009-524  
 N17-T-350009-576  
 N17-T-350009-888  
 N17-T-350009-897  
 N17-T-350010-258  
 N17-T-350010-399  
 N17-T-350012-235  
 N17-T-350012-236  
 N17-T-350012-310  
 N17-T-350012-331  
 N17-T-350012-484  
 N17-T-350012-485  
 N17-T-350012-486  
 N17-T-350012-487  
 N17-T-350012-507  
 N17-T-350012-623  
 N17-T-350012-634  
 N17-T-350012-636  
 N17-T-350012-638  
 N17-T-350012-646  
 N17-T-350012-655  
 N17-T-350012-657  
 N17-T-350012-693  
 N17-T-350012-702  
 N17-T-350012-708  
 N17-T-350012-711  
 N17-T-350012-717  
 N17-T-350012-719  
 N17-T-350012-742  
 N17-T-350012-990  
 N17-T-350012-991  
 N17-T-350013-106  
 N17-T-350013-120  
 N17-T-350013-122  
 N17-T-350013-124  
 N17-T-350013-133  
 N17-T-350013-144  
 N17-T-350013-155  
 N17-T-350013-160  
 N17-T-350013-165  
 N17-T-350013-169  
 N17-T-350013-170  
 N17-T-350013-176  
 N17-T-350013-181  
 N17-T-350013-188  
 N17-T-350013-195  
 N17-T-350013-202  
 N17-T-350013-206  
 N17-T-350013-209  
 N17-T-350013-243  
 N17-T-350013-247  
 N17-T-350013-301  
 N17-T-350013-359

H-1467  
 H-1566  
 H-296  
 H-1307  
 H-1115  
 H-1484  
 H-1402  
 O-121  
 O-250  
 H-392  
 O-1432  
 H-1163  
 H-119  
 H-106  
 H-278  
 H-1590  
 E-617  
 H-104  
 H-799  
 H-801  
 H-774  
 H-337  
 H-805  
 H-704  
 O-1596  
 O-102  
 O-125  
 O-2064  
 O-273  
 H-1425  
 O-1482  
 H-1142  
 H-1912  
 H-1379  
 H-189  
 H-366  
 H-794  
 H-1147  
 H-291  
 H-509  
 H-543  
 H-311  
 H-2057  
 H-302  
 H-1108  
 H-293  
 H-1735  
 H-2171  
 H-1324  
 H-1401  
 H-292  
 H-1481  
 H-330  
 H-150

N17-T-350013-679  
 N17-T-350013-680  
 N17-T-350013-681  
 N17-T-350013-682  
 N17-T-350013-683  
 N17-T-350013-684  
 N17-T-350013-685  
 N17-T-350013-686  
 N17-T-350013-687  
 N17-T-350013-688  
 N17-T-350013-689  
 N17-T-350013-690  
 N17-T-350013-691  
 N17-T-350013-692  
 N17-T-350013-693  
 N17-T-350013-694  
 N17-T-350013-695  
 N17-T-350013-696  
 N17-T-350013-697  
 N17-T-350013-698  
 N17-T-350013-699  
 N17-T-350013-700  
 N17-T-350013-701  
 N17-T-350013-704  
 N17-T-350013-705  
 N17-T-350013-706  
 N17-T-350013-707  
 N17-T-350013-708  
 N17-T-350013-709  
 N17-T-350013-710  
 N17-T-350013-711  
 N17-T-350013-712  
 N17-T-350013-713  
 N17-T-350013-714  
 N17-T-350013-715  
 N17-T-350013-716  
 N17-T-350013-717  
 N17-T-350013-718  
 N17-T-350013-719  
 N17-T-350013-720  
 N17-T-350013-721  
 N17-T-350013-722  
 N17-T-350013-723  
 N17-T-350013-724  
 N17-T-350013-725  
 N17-T-350013-726  
 N17-T-350013-727  
 N17-T-350013-729  
 N17-T-350013-730  
 N17-T-350013-731  
 N17-T-350013-732  
 N17-T-350013-733  
 N17-T-350013-734  
 N17-T-350013-735

O-238  
 O-233  
 A-113  
 O-205  
 H-261  
 A-101  
 O-118  
 O-114  
 O-112  
 O-113  
 O-111  
 O-116  
 O-101  
 O-108  
 O-105  
 O-104  
 O-120  
 O-203  
 O-204  
 H-187  
 A-114  
 A-116  
 A-118  
 O-278  
 H-140  
 O-232  
 O-124  
 A-103  
 H-126  
 H-153  
 O-216  
 H-231  
 O-141  
 E-103  
 A-112  
 O-146  
 O-251  
 O-129  
 O-130  
 A-1105  
 O-1112  
 A-1104  
 E-1104  
 O-1106  
 O-1105  
 TB-1101  
 E-1101  
 TB-101  
 H-1131  
 O-1104  
 O-1101  
 A-1102  
 E-1105  
 H-1109

N17-T-350013-811  
 N17-T-350013-812  
 N17-T-350013-813  
 N17-T-350013-814  
 N17-T-350013-815  
 N17-T-350013-816  
 N17-T-350013-817  
 N17-T-350013-818  
 N17-T-350013-819  
 N17-T-350013-820  
 N17-T-350013-821  
 N17-T-350013-822  
 N17-T-350013-823  
 N17-T-350013-824  
 N17-T-350013-825  
 N17-T-350013-826  
 N17-T-350013-827  
 N17-T-350013-828  
 N17-T-350013-829  
 N17-T-350013-830  
 N17-T-350013-831  
 N17-T-350013-832  
 N17-T-350013-833  
 N17-T-350013-834  
 N17-T-350013-835  
 N17-T-350013-836  
 N17-T-350013-837  
 N17-T-350013-838  
 N17-T-350013-839  
 N17-T-350013-840  
 N17-T-350013-841  
 N17-T-350013-842  
 N17-T-350013-843  
 N17-T-350013-844  
 N17-T-350013-845  
 N17-T-350013-846  
 N17-T-350013-847  
 N17-T-350013-848  
 N17-T-350013-849  
 N17-T-350013-850  
 N17-T-350013-851  
 N17-T-350013-852  
 N17-T-350013-853  
 N17-T-350013-854  
 N17-T-350013-855  
 N17-T-350013-856  
 N17-T-350013-857  
 N17-T-350013-858  
 N17-T-350013-859  
 N17-T-350013-860  
 N17-T-350013-861  
 N17-T-350013-862  
 N17-T-350013-863  
 N17-T-350013-864

O-1807  
 O-1771  
 O-265  
 O-1325  
 O-1322  
 O-1783  
 O-1840  
 O-1766  
 O-1788  
 O-1769  
 O-1791  
 O-1858  
 O-1859  
 O-1860  
 O-1861  
 O-1878  
 O-1879  
 O-1880  
 O-1881  
 O-1882  
 O-1883  
 O-1884  
 O-1885  
 O-1886  
 O-1887  
 O-1888  
 O-1889  
 O-1890  
 O-1891  
 O-1892  
 O-1893  
 O-1894  
 O-1895  
 O-1896  
 O-1897  
 O-1898  
 O-1899  
 O-1900  
 O-1901  
 O-1902  
 O-1903  
 O-1904  
 O-1905  
 O-1906  
 O-1907  
 O-1908  
 O-1530  
 O-1862  
 O-1863  
 O-1864  
 O-1865  
 O-1866  
 O-1867  
 O-1868

TABLE 8-5. CROSS REFERENCE PARTS LISTS

FEDERAL STOCK NUMBER	KEY SYMBOL	FEDERAL STOCK NUMBER	KEY SYMBOL	FEDERAL STOCK NUMBER	KEY SYMBOL	FEDERAL STOCK NUMBER	KEY SYMBOL
N17-T-350013-865	O-1869	N17-T-350013-974	O-2081	N17-T-350014-179	O-162	N17-T-350014-287	O-1624
N17-T-350013-866	O-1870	N17-T-350013-975	O-2069	N17-T-350014-180	O-163	N17-T-350014-288	O-1978
N17-T-350013-867	O-1871	N17-T-350013-976	O-2073	N17-T-350014-181	O-164	N17-T-350014-289	O-2054
N17-T-350013-868	O-1872	N17-T-350013-977	O-2076	N17-T-350014-182	O-165	N17-T-350014-290	A-1335
N17-T-350013-869	O-1873	N17-T-350013-978	O-2063	N17-T-350014-183	O-166	N17-T-350014-291	O-2070
N17-T-350013-870	O-1874	N17-T-350013-979	O-1471	N17-T-350014-184	O-167	N17-T-350014-292	O-1386
N17-T-350013-871	O-1875	N17-T-350013-980	O-2122	N17-T-350014-185	O-168	N17-T-350014-293	O-1672
N17-T-350013-872	O-1876	N17-T-350013-981	O-1526	N17-T-350014-186	O-169	N17-T-350014-294	A-1329
N17-T-350013-873	O-1877	N17-T-350013-982	A-1321	N17-T-350014-187	O-170	N17-T-350014-295	O-1693
N17-T-350013-874	O-2123	N17-T-350013-983	O-1503	N17-T-350014-188	O-1990	N17-T-350014-296	O-2067
N17-T-350013-875	O-2124	N17-T-350013-984	O-2097	N17-T-350014-189	O-1988	N17-T-350014-297	O-1687
N17-T-350013-876	O-2125	N17-T-350013-985	O-1351	N17-T-350014-190	H-1963	N17-T-350014-298	O-1784
N17-T-350013-877	O-2126	N17-T-350013-986	O-1350	N17-T-350014-191	O-1986	N17-T-350014-299	O-1690
N17-T-350013-878	O-2127	N17-T-350013-987	O-1354	N17-T-350014-192	O-1408	N17-T-350014-300	O-1689
N17-T-350013-879	O-2128	N17-T-350013-988	O-1384	N17-T-350014-193	O-1407	N17-T-350014-313	O-602
N17-T-350013-880	O-2104	N17-T-350013-989	O-1361	N17-T-350014-194	A-1315	N17-T-350014-314	E-601
N17-T-350013-881	O-1417	N17-T-350013-990	H-1386	N17-T-350014-195	O-1976	N17-T-350014-315	A-606
N17-T-350013-882	O-1455	N17-T-350013-991	O-1366	N17-T-350014-196	O-2033	N17-T-350014-316	A-605
N17-T-350013-883	O-1410	N17-T-350013-992	O-1365	N17-T-350014-197	O-1444	N17-T-350014-317	A-607
N17-T-350013-884	O-1415	N17-T-350013-993	H-1358	N17-T-350014-198	O-1443	N17-T-350014-318	O-1712
N17-T-350013-885	O-1412	N17-T-350013-994	O-1360	N17-T-350014-199	O-1442	N17-T-350014-319	O-1936
N17-T-350013-886	O-1409	N17-T-350013-995	O-1347	N17-T-350014-200	O-1433	N17-T-350014-320	O-2025
N17-T-350013-887	O-1411	N17-T-350013-996	H-1966	N17-T-350014-201	O-2121	N17-T-350014-321	O-1431
N17-T-350013-888	H-1509	N17-T-350013-997	A-1311	N17-T-350014-202	A-1332	N17-T-350014-322	O-1436
N17-T-350013-889	O-1688	N17-T-350013-998	O-1353	N17-T-350014-203	O-1536	N17-T-350014-323	O-2085
N17-T-350013-890	E-610	N17-T-350013-999	O-1385	N17-T-350014-204	O-1543	N17-T-350014-324	O-2087
N17-T-350013-891	O-1961	N17-T-350014-101	O-184	N17-T-350014-205	A-1333	N17-T-350014-325	O-1967
N17-T-350013-892	O-1970	N17-T-350014-102	O-183	N17-T-350014-206	O-1435	N17-T-350014-326	O-1962
N17-T-350013-893	A-505	N17-T-350014-103	O-182	N17-T-350014-207	O-1809	N17-T-350014-327	O-1757
N17-T-350013-894	O-219	N17-T-350014-104	O-181	N17-T-350014-208	O-1438	N17-T-350014-328	H-1634
N17-T-350013-895	A-503	N17-T-350013-105	O-180	N17-T-350014-209	A-1339	N17-T-350014-329	O-1965
N17-T-350013-896	O-246	N17-T-350014-106	O-179	N17-T-350014-210	A-1337	N17-T-350014-330	H-1954
N17-T-350013-897	O-243	N17-T-350014-107	O-178	N17-T-350014-211	H-1411	N17-T-350014-331	A-1338
N17-T-350013-898	W-1102	N17-T-350014-108	O-177	N17-T-350014-212	O-1437	N17-T-350014-332	O-1311
N17-T-350013-899	O-1917	N17-T-350014-109	O-176	N17-T-350014-213	H-1397	N17-T-350014-333	O-2039
N17-T-350013-902	S-501	N17-T-350014-110	O-175	N17-T-350014-214	O-1349	N17-T-350014-335	O-1666
N17-T-350013-903	S-503	N17-T-350014-111	O-174	N17-T-350014-215	O-1592	N17-T-350014-336	O-1655
N17-T-350013-905	O-1583	N17-T-350014-112	O-2075	N17-T-350014-216	O-1348	N17-T-350014-337	O-1653
N17-T-350013-906	O-1547	N17-T-350014-113	O-2071	N17-T-350014-217	O-2077	N17-T-350014-338	O-1951
N17-T-350013-907	O-1363	N17-T-350014-114	O-2074	N17-T-350014-218	A-1327	N17-T-350014-339	H-1836
N17-T-350013-908	H-1770	N17-T-350014-115	O-1808	N17-T-350014-219	O-1495	N17-T-350014-340	O-1368
N17-T-350013-909	O-1704	N17-T-350014-116	H-101	N17-T-350014-220	O-1754	N17-T-350014-341	O-1375
N17-T-350013-910	O-1853	N17-T-350014-117	O-1855	N17-T-350014-221	O-1496	N17-T-350014-343	O-1378
N17-T-350013-911	O-1594	N17-T-350014-118	O-1857	N17-T-350014-223	O-1505	N17-T-350014-344	O-1558
N17-T-350013-912	O-1613	N17-T-350014-119	O-1852	N17-T-350014-224	O-2092	N17-T-350014-345	O-1485
N17-T-350013-913	O-1313	N17-T-350014-120	H-1852	N17-T-350014-225	E-1308	N17-T-350014-346	O-1484
N17-T-350013-914	O-1608	N17-T-350014-121	H-1858	N17-T-350014-226	O-1529	N17-T-350014-347	O-1641
N17-T-350013-915	O-1668	N17-T-350014-122	O-1849	N17-T-350014-227	H-1988	N17-T-350014-348	O-1441
N17-T-350013-916	O-1422	N17-T-350014-123	O-1845	N17-T-350014-228	O-171	N17-T-350014-349	H-1479

N17-T-350013-917  
 N17-T-350013-918  
 N17-T-350013-919  
 N17-T-350013-920  
 N17-T-350013-921  
 N17-T-350013-922  
 N17-T-350013-924  
 N17-T-350013-925  
 N17-T-350013-926  
 N17-T-350013-927  
 N17-T-350013-928  
 N17-T-350013-929  
 N17-T-350013-930  
 N17-T-350013-931  
 N17-T-350013-932  
 N17-T-350013-933  
 N17-T-350013-934  
 N17-T-350013-935  
 N17-T-350013-936  
 N17-T-350013-937  
 N17-T-350013-938  
 N17-T-350013-939  
 N17-T-350013-940  
 N17-T-350013-941  
 N17-T-350013-942  
 N17-T-350013-943  
 N17-T-350013-944  
 N17-T-350013-945  
 N17-T-350013-946  
 N17-T-350013-947  
 N17-T-350013-948  
 N17-T-350013-949  
 N17-T-350013-950  
 N17-T-350013-951  
 N17-T-350013-952  
 N17-T-350013-953  
 N17-T-350013-954  
 N17-T-350013-955  
 N17-T-350013-956  
 N17-T-350013-957  
 N17-T-350013-959  
 N17-T-350013-960  
 N17-T-350013-961  
 N17-T-350013-962  
 N17-T-350013-963  
 N17-T-350013-964  
 N17-T-350013-965  
 N17-T-350013-966  
 N17-T-350013-967  
 N17-T-350013-968  
 N17-T-350013-970  
 N17-T-350013-971  
 N17-T-350013-972  
 N17-T-350013-973

O-1702  
 O-1497  
 O-2129  
 O-2114  
 E-1303  
 O-1671  
 O-1616  
 O-2038  
 O-1935  
 O-1685  
 O-1406  
 H-1968  
 O-1983  
 O-1982  
 O-1367  
 O-1828  
 O-1985  
 H-1593  
 O-1604  
 O-1610  
 O-1612  
 O-2057  
 O-2056  
 H-1570  
 O-1631  
 H-1630  
 H-1569  
 O-1980  
 O-1972  
 O-1974  
 O-1571  
 O-1572  
 O-1570  
 O-1554  
 H-1525  
 O-1633  
 O-1632  
 H-1555  
 O-1562  
 H-1554  
 A-1325  
 A-1326  
 O-1981  
 O-1629  
 O-1312  
 O-1550  
 O-1534  
 O-1842  
 O-1532  
 O-1681  
 O-1615  
 O-2072  
 O-2078  
 H-2080

N17-T-350014-124  
 N17-T-350014-125  
 N17-T-350014-126  
 N17-T-350014-127  
 N17-T-350014-128  
 N17-T-350014-129  
 N17-T-350014-130  
 N17-T-350014-131  
 N17-T-350014-132  
 N17-T-350014-133  
 N17-T-350014-134  
 N17-T-350014-135  
 N17-T-350014-136  
 N17-T-350014-137  
 N17-T-350014-138  
 N17-T-350014-139  
 N17-T-350014-140  
 N17-T-350014-141  
 N17-T-350014-142  
 N17-T-350014-143  
 N17-T-350014-144  
 N17-T-350014-145  
 N17-T-350014-146  
 N17-T-350014-147  
 N17-T-350014-148  
 N17-T-350014-149  
 N17-T-350014-150  
 N17-T-350014-151  
 N17-T-350014-152  
 N17-T-350014-153  
 N17-T-350014-154  
 N17-T-350014-155  
 N17-T-350014-156  
 N17-T-350014-157  
 N17-T-350014-158  
 N17-T-350014-160  
 N17-T-350014-161  
 N17-T-350014-162  
 N17-T-350014-163  
 N17-T-350014-164  
 N17-T-350014-165  
 N17-T-350014-166  
 N17-T-350014-167  
 N17-T-350014-168  
 N17-T-350014-169  
 N17-T-350014-170  
 N17-T-350014-171  
 N17-T-350014-172  
 N17-T-350014-173  
 N17-T-350014-174  
 N17-T-350014-175  
 N17-T-350014-176  
 N17-T-350014-177  
 N17-T-350014-178

O-1851  
 O-1847  
 O-1848  
 H-1316  
 A-1302  
 H-1907  
 O-1321  
 O-1767  
 O-1582  
 O-1586  
 H-2023  
 O-1694  
 O-1593  
 O-1595  
 O-1535  
 O-1630  
 H-1665  
 O-1590  
 H-1701  
 O-1597  
 O-1598  
 O-1692  
 O-1566  
 O-1591  
 O-1563  
 O-1544  
 O-1611  
 A-1306  
 A-1307  
 O-1395  
 O-1356  
 O-1400  
 O-1364  
 O-1402  
 O-1331  
 O-1346  
 O-1328  
 H-1408  
 O-1424  
 O-1425  
 A-1308  
 O-2101  
 O-1829  
 O-312  
 O-156  
 O-151  
 O-153  
 O-154  
 O-155  
 O-152  
 O-158  
 O-157  
 O-159  
 O-161

N17-T-350014-229  
 N17-T-350014-230  
 N17-T-350014-231  
 N17-T-350014-232  
 N17-T-350014-233  
 N17-T-350014-234  
 N17-T-350014-235  
 N17-T-350014-236  
 N17-T-350014-237  
 N17-T-350014-238  
 N17-T-350014-239  
 N17-T-350014-240  
 N17-T-350014-241  
 N17-T-350014-242  
 N17-T-350014-244  
 N17-T-350014-245  
 N17-T-350014-246  
 N17-T-350014-247  
 N17-T-350014-248  
 N17-T-350014-249  
 N17-T-350014-250  
 N17-T-350014-251  
 N17-T-350014-252  
 N17-T-350014-253  
 N17-T-350014-254  
 N17-T-350014-255  
 N17-T-350014-256  
 N17-T-350014-257  
 N17-T-350014-258  
 N17-T-350014-259  
 N17-T-350014-260  
 N17-T-350014-261  
 N17-T-350014-262  
 N17-T-350014-266  
 N17-T-350014-267  
 N17-T-350014-268  
 N17-T-350014-269  
 N17-T-350014-270  
 N17-T-350014-271  
 N17-T-350014-272  
 N17-T-350014-273  
 N17-T-350014-274  
 N17-T-350014-275  
 N17-T-350014-276  
 N17-T-350014-277  
 N17-T-350014-278  
 N17-T-350014-279  
 N17-T-350014-280  
 N17-T-350014-281  
 N17-T-350014-282  
 N17-T-350014-283  
 N17-T-350014-284  
 N17-T-350014-285  
 N17-T-350014-286

O-172  
 O-173  
 O-1344  
 O-1421  
 O-1329  
 A-1304  
 O-1330  
 O-1675  
 O-1669  
 O-1984  
 O-1940  
 A-1341  
 O-2094  
 H-141  
 H-793  
 O-1103  
 O-1102  
 A-1101  
 O-187  
 O-186  
 O-185  
 O-160  
 O-1343  
 O-1768  
 O-1565  
 O-1605  
 O-1339  
 O-1341  
 A-1309  
 O-1502  
 H-1486  
 O-1993  
 O-1659  
 O-1657  
 O-1639  
 O-1646  
 O-1663  
 O-1647  
 O-1545  
 O-1540  
 H-2046  
 H-2011  
 O-2036  
 O-2051  
 O-2021  
 O-2030  
 O-1682  
 O-1926  
 H-1673  
 H-1838  
 O-2068  
 O-2066  
 O-1623  
 O-1622

N17-T-350014-350  
 N17-T-350014-351  
 N17-T-350014-352  
 N17-T-350014-353  
 N17-T-350014-354  
 N17-T-350014-355  
 N17-T-350014-356  
 N17-T-350014-358  
 N17-T-350014-359  
 N17-T-350014-360  
 N17-T-350014-361  
 N17-T-350014-362  
 N17-T-350014-364  
 N17-T-350014-365  
 N17-T-350014-366  
 N17-T-350014-367  
 N17-T-350014-368  
 N17-T-350014-369  
 N17-T-350014-370  
 N17-T-350014-371  
 N17-T-350014-372  
 N17-T-350014-373  
 N17-T-350014-374  
 N17-T-350014-375  
 N17-T-350014-376  
 N17-T-350014-377  
 N17-T-350014-378  
 N17-T-350014-379  
 N17-T-350014-380  
 N17-T-350014-381  
 N17-T-350014-382  
 N17-T-350014-383  
 N17-T-350014-384  
 N17-T-350014-385  
 N17-T-350014-386  
 N17-T-350014-394  
 N17-T-350014-395  
 N17-T-350014-396  
 N17-T-350014-397  
 N17-T-350014-398  
 N17-T-350014-400  
 N17-T-350014-401  
 N17-T-350014-402  
 N17-T-350014-403  
 N17-T-350014-404  
 N17-T-350014-405  
 N17-T-350014-406  
 N17-T-350014-407  
 N17-T-350014-408  
 N17-T-350014-409  
 N17-T-350014-410  
 N17-T-350014-411  
 N17-T-350014-412  
 N17-T-350014-413

O-1440  
 H-1465  
 H-1518  
 E-101  
 O-2086  
 O-1606  
 H-1180  
 H-1788  
 O-1607  
 O-1487  
 O-1498  
 H-2159  
 B-601  
 O-1977  
 O-270  
 H-2119  
 A-1334  
 O-1785  
 A-1324  
 E-614  
 E-603  
 O-608  
 E-606  
 H-659  
 A-604  
 A-603  
 H-627  
 H-658  
 O-604  
 H-637  
 O-603  
 A-602  
 A-601  
 O-601  
 O-1387  
 H-702  
 H-777  
 O-134  
 O-227  
 O-228  
 O-142  
 O-280  
 O-281  
 A-107  
 O-149  
 O-126  
 O-128  
 H-157  
 O-283  
 O-252  
 H-276  
 H-265  
 H-368  
 O-144

TABLE 8-5. CROSS REFERENCE PARTS LISTS

FEDERAL STOCK NUMBER	KEY SYMBOL	FEDERAL STOCK NUMBER	KEY SYMBOL	FEDERAL STOCK NUMBER	KEY SYMBOL	FEDERAL STOCK NUMBER	KEY SYMBOL
N17-T-350014-414	O-224	N17-T-350014-544	O-1500	N17-T-350014-647	A-1303	N17-T-350014-785	H-300
N17-T-350014-415	O-290	N17-T-350014-546	O-1490	N17-T-350014-648	A-1305	N17-T-350014-786	H-1452
N17-T-350014-416	O-351	N17-T-350014-547	H-1521	N17-T-350014-649	O-2005	N17-T-350014-797	H-2169
N17-T-350014-417	O-358	N17-T-350014-548	A-1322	N17-T-350014-650	O-1921	N17-T-350014-802	O-1942
N17-T-350014-418	H-294	N17-T-350014-549	O-1609	N17-T-350014-651	O-2031	N17-T-350014-832	O-1772
N17-T-350014-419	H-367	N17-T-350014-550	O-1429	N17-T-350014-652	H-1896	N17-T-350014-833	O-1303
N17-T-350014-420	H-335	N17-T-350014-551	O-1428	N17-T-350014-653	O-1846	N17-T-350014-834	H-1563
N17-T-350014-421	H-260	N17-T-350014-552	O-1994	N17-T-350014-654	O-1919	N17-T-350014-835	W-1304
N17-T-350014-422	H-321	N17-T-350014-553	O-1602	N17-T-350014-655	O-1996	N17-T-350014-836	O-1589
N17-T-350014-423	H-357	N17-T-350014-554	O-1564	N17-T-350014-656	O-1915	N17-T-350014-837	O-2016
N17-T-350014-424	H-314	N17-T-350014-555	O-1755	N17-T-350014-657	H-1837	N17-T-350014-838	W-1303
N17-T-350014-425	O-272	N17-T-350014-556	A-1331	N17-T-350014-658	O-2048	N17-T-350014-839	O-1567
N17-T-350014-426	O-223	N17-T-350014-557	O-2053	N17-T-350014-659	H-1868	N17-T-350014-840	O-1617
N17-T-350014-427	O-509	N17-T-350014-558	O-1787	N17-T-350014-660	O-1995	N17-T-350014-841	O-1619
N17-T-350014-428	O-213	N17-T-350014-559	O-1786	N17-T-350014-661	O-1914	N17-T-350014-842	O-1691
N17-T-350014-429	O-192	N17-T-350014-560	O-1725	N17-T-350014-662	O-1945	N17-T-350014-843	O-2043
N17-T-350014-430	O-1504	N17-T-350014-562	O-2035	N17-T-350014-663	O-2050	N17-T-350014-844	O-2044
N17-T-350014-431	O-150	N17-T-350014-563	O-320	N17-T-350014-664	H-1979	N17-T-350014-845	O-1662
N17-T-350014-432	O-234	N17-T-350014-564	O-302	N17-T-350014-665	H-1980	N17-T-350014-846	W-1302
N17-T-350014-433	O-261	N17-T-350014-565	O-131	N17-T-350014-666	H-1992	N17-T-350014-847	O-1854
N17-T-350014-434	A-108	N17-T-350014-566	O-318	N17-T-350014-667	H-1881	N17-T-350014-848	H-230
N17-T-350014-435	O-297	N17-T-350014-567	O-210	N17-T-350014-668	O-2010	N17-T-350014-850	W-1101
N17-T-350014-436	O-260	N17-T-350014-568	O-307	N17-T-350014-669	O-1933	N17-T-350014-851	E-757
N17-T-350014-437	O-257	N17-T-350014-569	O-306	N17-T-350014-670	O-1734	N17-T-350014-852	O-1568
N17-T-350014-438	O-275	N17-T-350014-571	O-239	N17-T-350014-671	O-1943	N17-T-350014-853	O-1327
N17-T-350014-439	O-508	N17-T-350014-572	O-236	N17-T-350014-672	O-1930	N17-T-350014-855	H-131
N17-T-350014-440	H-243	N17-T-350014-573	O-291	N17-T-350014-673	O-1922	N17-T-350014-856	A-1107
N17-T-350014-441	O-230	N17-T-350014-574	A-105	N17-T-350014-674	O-2046	N17-T-350014-857	A-1108
N17-T-350014-442	H-245	N17-T-350014-575	H-327	N17-T-350014-675	O-2004	N17-T-350014-858	O-209
N17-T-350014-443	O-229	N17-T-350014-576	A-119	N17-T-350014-676	H-1886	N17-T-350014-860	E-102
N17-T-350014-444	H-182	N17-T-350014-577	O-292	N17-T-350014-677	O-1724	N17-T-350014-861	O-2052
N17-T-350014-445	O-135	N17-T-350014-578	H-274	N17-T-350014-678	O-2024	N17-T-350014-862	H-393
N17-T-350014-446	O-140	N17-T-350014-579	H-281	N17-T-350014-679	O-2026	N17-T-350014-863	O-763
N17-T-350014-447	O-139	N17-T-350014-580	O-237	N17-T-350014-680	O-1478	N17-T-350014-864	W-101
N17-T-350014-448	O-138	N17-T-350014-581	H-283	N17-T-350014-681	O-1585	N17-T-350014-865	O-1599
N17-T-350014-449	O-137	N17-T-350014-582	O-244	N17-T-350014-682	O-1810	N17-T-350014-866	O-1521
N17-T-350014-450	O-136	N17-T-350014-583	O-286	N17-T-350014-683	O-1811	N17-T-350014-867	O-1305
N17-T-350014-451	H-179	N17-T-350014-584	O-119	N17-T-350014-684	O-1812	N17-T-350014-871	O-298
N17-T-350014-452	O-143	N17-T-350014-585	A-122	N17-T-350014-685	A-1330	N17-T-350014-884	H-399
N17-T-350014-453	A-106	N17-T-350014-586	O-765	N17-T-350014-686	O-1703	N17-T-350014-885	O-305
N17-T-350014-454	O-200	N17-T-350014-587	O-755	N17-T-350014-687	O-1527	N17-T-350014-887	H-374
N17-T-350014-455	O-199	N17-T-350014-588	H-2157	N17-T-350014-688	O-2120	N17-T-350014-888	O-1501
N17-T-350014-456	H-166	N17-T-350014-589	O-2117	N17-T-350014-689	O-2106	N17-T-350014-889	H-1437
N17-T-350014-457	H-325	N17-T-350014-590	H-121	N17-T-350014-690	O-2109	N17-T-350014-890	H-113
N17-T-350014-458	O-259	N17-T-350014-591	H-201	N17-T-350014-691	O-2107	N17-T-350014-891	H-530
N17-T-350014-459	O-193	N17-T-350014-592	H-623	N17-T-350014-692	O-2115	N17-T-350014-893	O-249
N17-T-350014-460	O-211	N17-T-350014-593	H-297	N17-T-350014-693	O-1480	N17-T-350014-894	Q-1491
N17-T-350014-461	H-128	N17-T-350014-594	H-132	N17-T-350014-694	H-1485	N17-T-350014-895	H-813

N17-T-350014-462  
 N17-T-350014-463  
 N17-T-350014-464  
 N17-T-350014-465  
 N17-T-350014-466  
 N17-T-350014-467  
 N17-T-350014-468  
 N17-T-350014-469  
 N17-T-350014-470  
 N17-T-350014-471  
 N17-T-350014-472  
 N17-T-350014-473  
 N17-T-350014-474  
 N17-T-350014-475  
 N17-T-350014-476  
 N17-T-350014-477  
 N17-T-350014-478  
 N17-T-350014-479  
 N17-T-350014-480  
 N17-T-350014-481  
 N17-T-350014-482  
 N17-T-350014-483  
 N17-T-350014-484  
 N17-T-350014-485  
 N17-T-350014-486  
 N17-T-350014-487  
 N17-T-350014-488  
 N17-T-350014-489  
 N17-T-350014-490  
 N17-T-350014-491  
 N17-T-350014-492  
 N17-T-350014-493  
 N17-T-350014-513  
 N17-T-350014-514  
 N17-T-350014-515  
 N17-T-350014-527  
 N17-T-350014-528  
 N17-T-350014-529  
 N17-T-350014-530  
 N17-T-350014-531  
 N17-T-350014-532  
 N17-T-350014-533  
 N17-T-350014-534  
 N17-T-350014-535  
 N17-T-350014-536  
 N17-T-350014-537  
 N17-T-350014-538  
 N17-T-350014-539  
 N17-T-350014-540  
 N17-T-350014-541  
 N17-T-350014-542  
 N17-T-350014-543

O-212  
 O-122  
 O-201  
 O-207  
 O-202  
 O-507  
 O-505  
 O-506  
 O-279  
 H-323  
 H-129  
 A-109  
 O-215  
 O-276  
 H-257  
 E-104  
 H-389  
 O-304  
 E-105  
 A-120  
 E-107  
 A-121  
 E-106  
 O-225  
 H-373  
 A-104  
 O-285  
 O-313  
 O-218  
 A-110  
 O-301  
 O-274  
 O-1372  
 H-1104  
 O-614  
 O-1307  
 O-1541  
 O-1333  
 O-1352  
 O-1720  
 H-2111  
 O-1931  
 O-1957  
 O-1377  
 H-2118  
 O-2118  
 H-1464  
 H-1165  
 O-2105  
 H-2158  
 A-1320  
 H-1517

N17-T-350014-595  
 N17-T-350014-596  
 N17-T-350014-597  
 N17-T-350014-598  
 N17-T-350014-599  
 N17-T-350014-600  
 N17-T-350014-601  
 N17-T-350014-602  
 N17-T-350014-603  
 N17-T-350014-604  
 N17-T-350014-605  
 N17-T-350014-606  
 N17-T-350014-607  
 N17-T-350014-608  
 N17-T-350014-609  
 N17-T-350014-610  
 N17-T-350014-611  
 N17-T-350014-612  
 N17-T-350014-613  
 N17-T-350014-614  
 N17-T-350014-615  
 N17-T-350014-616  
 N17-T-350014-617  
 N17-T-350014-618  
 N17-T-350014-619  
 N17-T-350014-620  
 N17-T-350014-621  
 N17-T-350014-622  
 N17-T-350014-623  
 N17-T-350014-624  
 N17-T-350014-625  
 N17-T-350014-626  
 N17-T-350014-627  
 N17-T-350014-628  
 N17-T-350014-629  
 N17-T-350014-630  
 N17-T-350014-631  
 N17-T-350014-632  
 N17-T-350014-633  
 N17-T-350014-634  
 N17-T-350014-635  
 N17-T-350014-636  
 N17-T-350014-637  
 N17-T-350014-638  
 N17-T-350014-639  
 N17-T-350014-640  
 N17-T-350014-641  
 N17-T-350014-642  
 N17-T-350014-643  
 N17-T-350014-644  
 N17-T-350014-645  
 N17-T-350014-646

H-1564  
 O-1642  
 H-1403  
 O-1790  
 O-1399  
 H-193  
 H-2127  
 H-191  
 H-194  
 H-196  
 O-264  
 O-1781  
 O-266  
 O-262  
 O-1782  
 O-1801  
 O-1780  
 O-1799  
 O-1310  
 H-1308  
 O-1789  
 H-1302  
 O-1308  
 O-268  
 O-1334  
 O-1332  
 O-1337  
 O-1374  
 O-1373  
 O-1371  
 H-2108  
 H-1959  
 O-1369  
 O-1388  
 O-1580  
 O-1696  
 O-1706  
 H-2114  
 O-1737  
 O-1700  
 O-2032  
 O-1735  
 O-1711  
 O-1717  
 O-2018  
 H-1832  
 O-2017  
 O-2009  
 O-1925  
 O-2003  
 O-1928  
 O-1423

N17-T-350014-695  
 N17-T-350014-696  
 N17-T-350014-697  
 N17-T-350014-698  
 N17-T-350014-699  
 N17-T-350014-700  
 N17-T-350014-701  
 N17-T-350014-702  
 N17-T-350014-703  
 N17-T-350014-704  
 N17-T-350014-705  
 N17-T-350014-706  
 N17-T-350014-710  
 N17-T-350014-711  
 N17-T-350014-712  
 N17-T-350014-713  
 N17-T-350014-714  
 N17-T-350014-715  
 N17-T-350014-739  
 N17-T-350014-746  
 N17-T-350014-747  
 N17-T-350014-748  
 N17-T-350014-749  
 N17-T-350014-750  
 N17-T-350014-751  
 N17-T-350014-752  
 N17-T-350014-753  
 N17-T-350014-754  
 N17-T-350014-756  
 N17-T-350014-757  
 N17-T-350014-758  
 N17-T-350014-759  
 N17-T-350014-760  
 N17-T-350014-762  
 N17-T-350014-763  
 N17-T-350014-764  
 N17-T-350014-768  
 N17-T-350014-769  
 N17-T-350014-770  
 N17-T-350014-771  
 N17-T-350014-772  
 N17-T-350014-774  
 N17-T-350014-776  
 N17-T-350014-777  
 N17-T-350014-778  
 N17-T-350014-779  
 N17-T-350014-780  
 N17-T-350014-781  
 N17-T-350014-782  
 N17-T-350014-783  
 N17-T-350014-784

H-1487  
 O-1515  
 O-1510  
 O-1489  
 H-1488  
 O-1479  
 O-2108  
 A-1340  
 O-1973  
 O-2084  
 O-1947  
 O-314  
 O-208  
 H-353  
 A-102  
 H-273  
 O-226  
 E-501  
 O-1944  
 O-271  
 O-1778  
 O-269  
 O-267  
 O-1324  
 O-1342  
 O-1699  
 O-1844  
 W-1301  
 K-101  
 E-754  
 A-751  
 O-752  
 O-751  
 H-751  
 A-756  
 O-756  
 H-758  
 O-769  
 H-754  
 XI-751  
 O-760  
 O-770  
 O-759  
 H-752  
 A-757  
 O-768  
 E-755  
 O-766  
 O-762  
 A-702  
 O-1749  
 H-2082

N17-T-350014-896  
 N17-T-350014-897  
 N17-T-350014-898  
 N17-T-350014-899  
 N17-T-350014-900  
 N17-T-350014-901  
 N17-T-350014-902  
 N17-T-350014-905  
 N17-T-350014-906  
 N17-T-350014-907  
 N17-T-350014-908  
 N17-T-350014-909  
 N17-T-350014-910  
 N17-T-350014-911  
 N17-T-350014-912  
 N17-T-350014-913  
 N17-T-350014-914  
 N17-T-350014-922  
 N17-T-350014-923  
 N17-T-350014-924  
 N17-T-350014-925  
 N17-T-350014-926  
 N17-T-350014-927  
 N17-T-350014-928  
 N17-T-350014-929  
 N17-W-228001-120  
 N43-N-9699-190  
 N43-S-68788-430  
 N43-S-68828-1575  
 N43-S-68889-420  
 N43-S-68898-1035  
 N43-S-68898-1050  
 N43-S-68898-1330  
 N43-S-68898-1340  
 N43-W-6798-280  
 N43-S-99500-112  
 N43-W-6806-5540  
 N43-W-7520-5275  
 N43-W-7522-313  
 N43-W-7527-801  
 N43-W-99500-57  
 N77-B-111-01002-1000  
 N77-B-115-00609-0000  
 N77-B-115-00619-2004  
 N77-B-999-56012-0200

H-824  
 W-751  
 O-754  
 A-758  
 O-1483  
 O-366  
 H-818  
 Z-751  
 T-751  
 H-365  
 H-372  
 H-1409  
 H-1864  
 Z-101  
 O-253  
 O-1856  
 E-609  
 H-769  
 O-2131  
 H-1589  
 H-1367  
 O-263  
 O-1777  
 H-514  
 H-398  
 O-2130  
 H-753  
 H-1574  
 H-520  
 H-632  
 H-503  
 H-501  
 H-660  
 H-511  
 H-512  
 H-775  
 H-105  
 H-1174  
 O-1315  
 H-526  
 H-527  
 O-510  
 O-206  
 O-1756  
 O-231

TT-47/UG, TT-48/UG, TT-69/UG, TT-70/UG

TABLE 8-6. LIST OF MANUFACTURERS

PREFIX	NAME	ADDRESS
CG	General Electric Company	1 River Road, Schenectady 5, New York
CAE	Cutler Hammer Inc.	1333 W. St. Paul Avenue, Milwaukee, Wisconsin
CAO	Ward Leonard Company	6 South Street, Mount Vernon, New York
CFA	Bussman Manufacturing Company	2538 W. University Street, St. Louis, Missouri
CGM	General Motors Company	Detroit, Michigan
CHH	Arrow-Hart & Hegemen Electric Company	102 Hawthorn Street, Hartford, Connecticut
CHU	Harvey Hubbell Incorporated	447 Concord Avenue, Bridgeport, Connecticut
CIE	Industrial Condenser Corporation	1725 W. North Avenue, Chicago 22, Illinois
CJC	Howard B. Jones	2300 W. Wabansia Avenue, Chicago, Illinois
CMG	Cinch Manufacturing Company	2339 W. Van Buren Street, Chicago, Illinois
CTD	Tobe-Deutschmann Corporation	921 Providence Highway, Norwood, Massachusetts
CTT	Teletype Corporation	1400 W. Wrightwood Avenue, Chicago 14, Illinois
CAID	Chrysler Corporation	2200 E. Jefferson Ave., Detroit, Michigan
CARE	Potter & Brumfield Manufacturing Company, Inc.	Princeton, Indiana
CATK	Acro Electric Company	1305 Superior Avenue, Cleveland, Ohio
CAXO	Shakeproof Incorporated	2573 N. Keeler Avenue, Chicago, Illinois
CAYU	Barry Corporation	179 Sidney Street, Cambridge 39, Massachusetts
CAYZ	Dial Light Corporation	900 Broadway, New York, New York
	Appleton Electric Company	1713 W. Wellington Avenue, Chicago, Illinois
	Chicago Rawhide Company	1301 Elston Avenue, Chicago, Illinois
	Codo Manufacturing Company	509 S. Franklin Street, Chicago, Illinois
	Commercial Plastic Company	Room 1198, Merchandise Mart Plaza, Chicago, Illinois
	Davis Molding Company	1428 N. Wells Street, Chicago 10, Illinois
	First Industrial Corporation	Freeport, Illinois
	Norma-Hoffman	64 E. Jackson Boulevard, Chicago, Illinois
	Owens-Corning Fibreglass Corporation	35 E. Wacker Drive, Chicago, Illinois
	Tinnerman Products	Box 6688, Cleveland, Ohio
	Waldes Kohinoor Incorporated	Long Island City 1, New York
	Western Felt	4115 W. Ogden Avenue, Chicago, Illinois
	Winchester Electronics Incorporated	6 E. 46th Street, New York 17, New York

## INDEX

SUBJECT	FIGURE OR TABLE	PAGE	SUBJECT	FIGURE OR TABLE	PAGE
<b>A</b>			Printing carriage position .	7-67	7-75
Accessories . . . . .		1-4	Printing hammer bearing post . . . . .	7-70	7-78
AC Motor PD-17/U . . . . .	1-9	1-7	Printing hammer stop bracket . . . . .	7-70	7-78
PD-17A/U . . . . .	1-9A	1-8	Reversing slide adjusting plate . . . . .	7-56	7-64
PD-18/U . . . . .	1-10	1-8	Reversing slide extension .	7-56	7-64
Motors . . . . .		2-40	Ribbon reverse detent . . . .	7-71	7-79
Adjustments . . . . .		7-9	Ribbon reversing spur gear	7-71	7-79
Automatic Typer . . . . .		7-40	Ribbon unit feed lever bail bracket . . . . .	7-72	7-80
Armature alignment . . . . .	7-31	7-40	Right margin . . . . .	7-66	7-74
Armature backstop alignment . . . . .	7-31	7-40	Right vertical positioning lever eccentric stud . . . .	7-52	7-60
Armature clamp strip . . . .	7-31	7-40	Rocker shaft bracket eccentric stud . . . . .	7-51	7-59
Automatic carriage return arm . . . . .	7-79	7-86	Rocker shaft left bracket . .	7-50	7-58
Bell contact . . . . .	7-82	7-89	Selector clutch drum . . . . .	7-34	7-43
Carriage return latch bail .	7-62	7-70	Selector clutch operating bail . . . . .	7-39	7-48
Carriage return lever . . . . .	7-63	7-71	Selector clutch stop arm . .	7-40	7-49
Carriage wire rope . . . . .	7-60	7-68	Selector magnet bracket . .	7-33	7-42
Clutch shoe lever . . . . .	7-47	7-55	Shift code bar operating slides . . . . .	7-73	7-81
Clutch trip shaft set collars	7-43	7-52	Shift lever drive arm . . . .	7-37	7-46
Code bar clutch trip lever .	7-41	7-50	Shift lever link guide . . . .	7-38	7-47
Code bar detent . . . . .	7-84	7-91	Shift linkage . . . . .	7-68	7-76
Dashpot vent screw . . . . .	7-64	7-72	Shift slide drive linkage . .	7-57	7-65
Function clutch trip lever .	7-42	7-51	Spacing clutch trip lever . .	7-44	7-53
Function reset bail extension arm . . . . .	7-55	7-63	Spacing drum stop arm . . .	7-58	7-66
Function stripper blade arms . . . . .	7-76	7-84	Spacing gear clearance . . .	7-49	7-57
Intermediary arm backstop bracket . . . . .	7-36	7-45	Spacing gear phasing . . . .	7-49	7-57
Left hand margin . . . . .	7-65	7-73	Spacing trip lever bail cam plate . . . . .	7-54	7-62
Left vertical positioning lever eccentric stud . .	7-53	7-61	Transfer lever eccentric . . .	7-35	7-44
Line feed clutch phasing . .	7-50	7-58	Type box carriage roller . .	7-65	7-73
Line feed clutch trip lever adjusting screw . .	7-45	7-54	Type box clutch trip arm .	7-46	7-55
Line feed clutch trip lever eccentric post . . . . .	7-45	7-54	Type box clutch trip lever eccentric post . . . . .	7-45	7-54
Lock lever guide . . . . .	7-33	7-42	Unshift on space function pawl . . . . .	7-83	7-90
Magnet core . . . . .	7-32	7-41	Vertical positioning lock lever . . . . .	7-58	7-66
Paper finger . . . . .	7-81	7-88	Keyboard . . . . .		7-10
Paper straightener collar . .	7-80	7-87	Clutch shoe lever . . . . .	7-7	7-16
Platen gear detent eccentric	7-75	7-83	Clutch stop lever . . . . .	7-8	7-17
Printing arm . . . . .	7-70	7-78			
Printing carriage lower roller . . . . .	7-67	7-75			





SUBJECT	FIGURE OR TABLE	PAGE	SUBJECT	FIGURE OR TABLE	PAGE
Code bar detent mechanism	7-84	7-91	Clutch mechanism	7-7	7-16
Code bar shift mechanism	7-36	7-45	Code bar mechanism	7-14	7-23
Dashpot and keyboard lock mechanism	7-64	7-72	Code bar reset mechanism	7-11	7-20
Function box	7-74	7-82	Code lever bail	7-16	7-25
Function clutch mechanism	7-42	7-51	Contact box	7-10	7-19
Function pawl stripper mechanism	7-76, 7-78	7-84, 7-85	Gearing and motor gearing	7-23	7-32
Function reset bail extension arm	7-55	7-63	Key lever locking mechanism	7-18	7-27
Horizontal motion reversing mechanism	7-56	7-64	Label cover (plastic window)	7-29	7-38
Line feed and rocker shaft mechanisms	7-50	7-58	Local carriage return mechanism	7-25	7-34
Line feed mechanism	7-75	7-83	Local line feed mechanism	7-24	7-33
Paper mechanism	7-80	7-87	Lock mechanism	7-26	7-35
Printing carriage	7-67	7-75	Margin indicating mechanism	7-30	7-39
Printing mechanism	7-69	7-77	Mounting typer on	7-21	7-30
Ribbon feed mechanism	7-72	7-80	Non-repeat mechanism	7-13	7-22
Ribbon reverse mechanism	7-71	7-79	Reset bail and repeat slide	7-12	7-21
Right margin and drive linkage mechanisms	7-66	7-74	Reset mechanism	7-15	7-24
Selector cam clutch	7-34	7-43	Signal generator, front view	7-1	7-10
Selector clutch mechanism	7-40	7-49	Signal generator, rear view	7-3	7-12
Selector clutch operating bail	7-39	7-48	Space bar	7-17	7-26
Selector magnet	7-31	7-40	Time delay disabling device	7-28	7-37
Selector mechanism	7-33	7-42	Time delay mechanism	7-19, 7-27	7-28, 7-36
Shift and positioning mechanism	7-51	7-59	Miscellaneous		
Shift mechanism	7-68, 7-73	7-76, 7-81	Centrifugal mechanism	7-86	7-92
Shift slide drive mechanism	7-57	7-65	Motor control assembly	7-90	7-96
Spacing clutch mechanism	7-44	7-53	Motor governor	7-88	7-94
Spacing mechanism	7-49, 7-54, 7-59, 7-60	7-57, 7-62, 7-67, 7-68	Motor governor brush	7-89	7-95
Spacing suppression mechanism	7-77	7-84	Motor position	7-85	7-92
Transfer mechanism	7-35	7-44	Mounting typer on keyboard	7-21	7-30
Trip shaft mechanism	7-43	7-52	Remote signal bell	7-91	7-97
Type box clutch and line feed clutch mechanism	7-45	7-54	Starting switch	7-87	7-93
Type box clutch mechanism	7-46	7-55	Tools	7-93	7-101
Type box mechanism	7-65	7-73	Typer and signal generator gearing	7-22	7-31
Unshift on space mechanism	7-83	7-90	Window and accessories	7-92	7-98
Vertical positioning mechanism	7-58	7-66	Correction page		C
Vertical positioning mechanism, left	7-53	7-61	Cross reference parts list	8-5	8-192
Vertical positioning mechanism, right	7-52	7-60	Cubical contents of equipment		1-11
Keyboard		7-10			
			<b>D</b>		
			Description of components		1-1
			Automatic Typer		1-2
			Cabinets		1-3
			Keyboard		1-1
			Motors		1-3
			Power Distribution Panel		1-5
			Draw wire rope mechanism	2-44	2-21

SUBJECT	FIGURE OR TABLE	PAGE	SUBJECT	FIGURE OR TABLE	PAGE
<b>E</b>			<b>I</b>		
Effective pages, list of .....	.....	B	Intermediate gear mechanism .....	7-97	7-105
Electrical motor control .....	.....	2-43	Local line feed mechanism .....	7-100	7-105
Electrical motor control mechanism,			Lock mechanism .....	7-99	7-105
Open line position .....	2-81	2-44	Signal generator mechanism .....	7-102	7-107
Start position .....	2-82	2-45	Time delay mechanism .....	7-94	7-102
Stop position .....	2-80	2-44	Power distribution panel .....	7-111	7-116
Emergency maintenance .....	.....	5-1	Motor control mechanism .....	7-112	7-117
Equipment required but not supplied .....	1-3	1-13	Synchronous motor, PD-17/U .....	7-106	7-111
Equipment supplied .....	1-1	1-12	Synchronous motor, PD-17A/U .....	7-107	7-112
Exploded illustrations .....	.....	7-99	<b>F</b>		
Automatic typer			Failure report instructions .....	.....	7-0
Code bar mechanism .....	7-114	7-119	Final check .....	.....	3-6
Code bar positioning mechanism .....	7-134	7-139	Final test .....	.....	7-99
Front plate .....	7-121	7-126	Front plate horizontal positioning mechanism .....	2-47	2-23
Front Plate mechanism .....	7-120, 7-122	7-125, 7-127	Function box		
Function box .....	7-117	7-122	Front view showing function bars .....	2-57	2-30
Left ribbon feed mechanism .....	7-115	7-120	Rear view showing function levers .....	2-58	2-31
Left side frame mechanism .....	7-133	7-138	Function reset bail mechanism .....	2-59	2-32
Left side linkage and stripper blade .....	7-129	7-134	Function selection, top view .....	2-60	2-32
Line feed and platen mechanism .....	7-128	7-133	Functional block diagram .....	2-1	2-0
Main shaft mechanism .....	7-125	7-130	Functions .....	.....	2-28
Main shaft mechanism .....	7-125A	7-130A	Fuse locations .....	5-3	5-3
Paper spindle and reset bail .....	7-127	7-132	Fuse locations and symptoms of failure .....	.....	5-1
Pressure roller mechanism .....	7-131	7-136	<b>G</b>		
Printing carriage .....	7-113	7-118	General description .....	.....	1-1
Right ribbon feed mechanism .....	7-116	7-121	Automatic Typer .....	.....	1-2
Right side frame mechanism .....	7-132	7-137	Cabinets .....	.....	1-3
Right side linkage and type box .....	7-126	7-131	Keyboard .....	.....	1-1
Selector magnet assembly .....	7-118	7-123	Motors .....	.....	1-3
Selector mechanism .....	7-119	7-124	Power Distribution Panel .....	.....	1-5
Space suppression mechanism .....	7-130	7-135	Governed motor .....	.....	1-3
Spring drum mechanism .....	7-123	7-128	Governor for AC Motor PD-18/U .....	2-78	2-42
Trip shaft mechanism .....	7-124	7-129	Guarantee, contractual .....	.....	ix
Cabinet .....	7-109	7-114	<b>I</b>		
Governed motor .....	7-107A	7-112A	Illustrations, list of .....	.....	iv
Governor mechanism .....	7-108	7-113	Installation .....	.....	3-1
Keyboard mechanism .....	7-101	7-106	Installation and connections of electrical noise suppressor .....	3-3	3-3
Base mechanism .....	7-95	7-103	Installation record .....	.....	ix
Carriage return mechanism .....	7-98	7-105	Installing the cabinets .....	.....	3-1
Code bar mechanism .....	7-96	7-104	Intermediate shaft assembly .....	.....	2-2
			Introduction .....	.....	4-1

SUBJECT	FIGURE OR TABLE	PAGE
<b>K</b>		
Keyboard clutch throwout mechanism .....	2-12	2-6
Keyboard keys .....	1-3, 4-1	1-3, 4-1
Keyboard lock mechanism .....	2-26, 2-28, 2-75	2-10, 2-11, 2-40
Keyboard lock priming mechanism .....	2-74	2-39
Keyboard .....	1-2	1-2
Keyboard unlock mechanism ..	2-27	2-11
Keylever lock ball mechanism ..	2-5	2-3
Keylever mechanism, selected position .....	2-6	2-4
<b>L</b>		
Letters and figures shift functions .....		2-33
Letters-figures function slides		
Figures position .....	2-64	2-33
Letters position .....	2-63	2-33
Letters-figures shift mechanism, letters position .....	2-65	2-34
Line feed function .....		2-35
Line feed function and clutch trip mechanism .....	2-69	2-37
Line feed mechanism .....	2-71	2-38
List of tools .....	7-2	7-100
Local carriage return mechanism .....	2-21	2-8, 2-9
Local line feed .....		2-9
Local line feed mechanism .....	2-22	2-9
Lubrication .....		6-1
Automatic Typewriter .....		6-15
Cabinet .....		6-3
Keyboard .....		6-5
<b>M</b>		
Main shaft .....		2-12
Maintenance		
Check chart, routine .....	5-1	5-1
Corrective .....		7-1
Emergency .....		5-1
Operator's .....		5-1
Preventive .....		6-1
Major units, list of .....	8-3	8-2
Manufacturers, list of .....	8-6	8-198
Margin indicating lamp .....		3-6
Margin indicator .....		2-27
Margin indicator mechanism ..	2-29	2-11

SUBJECT	FIGURE OR TABLE	PAGE
Mechanical checking of equipment .....		3-5
Motors .....		2-40
Multiple copies .....		4-3
<b>N</b>		
Nomenclature .....		1-5
Non-repeat lever mechanism ..	2-11	2-6
<b>O</b>		
Off-line functions .....		4-2
On-line functions .....		4-1
Open line position .....		2-45
Operating test .....		3-5
Operation .....		4-1
Operator's maintenance .....		5-1
Ordering parts instructions .....		x
Orientation .....		2-15
Orientation range .....		4-4
Outline and mounting dimensions .....	3-5	3-7, 3-8
Overload cutout .....		4-6
<b>P</b>		
Paper and ribbon .....		4-3
Parts list .....	8-4	8-4
Parts ordering instructions .....		x
Parts diagrams (see exploded illustrations)		
Path of paper .....	4-4	4-5
Path of ribbon .....	4-5	4-5
Positioning mechanism for single or double line feed ...	2-70	2-38
Power and line connections .....		3-1
Power and signal line connections .....	3-2	3-2
Power distribution panel .....	1-12, 1-13, 4-3	1-10, 1-11, 2-43, 4-4
Power distribution panel connections .....	3-2, 3-3	3-2, 3-3
Power and signal line connections .....	3-2	3-2
Power supply requirements .....		1-11
Preventive maintenance .....		6-1
Automatic Typewriter .....	6-7	6-17
Cabinets .....	6-1	6-3
Keyboard .....	6-2	6-5
Primary power distribution diagram .....	3-1, 7-135	3-0, 7-140

## TT-47/UG, TT-48/UG, TT-69/UG, TT-70/UG

SUBJECT	FIGURE OR TABLE	PAGE	SUBJECT	FIGURE OR TABLE	PAGE
Printing .....		2-25	Routine checks .....		5-1
Printing hammer and printing carriage .....		2-25	Routine maintenance .....		6-1
Printing hammer mechanism			Routine maintenance check chart .....	6-1	6-2
Front view .....	2-49	2-26			
Top view .....	2-50	2-27	<b>S</b>		
Printing mechanism .....		2-15	Safety notice .....		x
Promulgating letter .....		B	Schematic wiring diagrams		
Purpose of the equipment .....		1-1	AC Motor (governed)		
			PD-18/U .....	2-77	2-42
<b>R</b>			AC Motor (synchronous)		
Receiving circuit .....		2-12	PD-17/U .....	2-76	2-40
Record of corrections made .....		C	AC Motor (synchronous)		
Removal and repair .....		7-3	PD-17A/U .....	2-76A	2-41
Code bar .....		7-9	Automatic Typewriter		
Code bar positioning mechanism .....		7-7	MX-1115/UG .....	2-33	2-13
Code bars .....		7-5	Keyboard MX-1114/UG ...	2-3	2-2
Front plate .....		7-4	Power Distribution Panel and Cabinets CY-870/UG and CY-871/UG .....	2-79	2-42A
Function bar .....		7-5	TT-47/UG, TT-48/UG, TT-69/UG and TT-70/UG	7-136	7-143
Function box .....		7-4	Scope of instruction book .....		1-1
Key Lever .....		7-8	Selecting mechanism .....		2-13
Key Lever Cover .....		7-8	Selecting mechanism, right end view .....	2-38	2-17
Key Lever Guide Plate .....		7-8	Selector cam-clutch trip mechanism .....	2-37	2-16
Keyboard ball lock track ...		7-8	Selector margins .....	7-1	7-99
Keyboard code bar assembly.		7-8	Shipping data .....	1-2	1-13
Keyboard label .....		7-8	Signal bell contact mechanism, Selected .....	2-73	2-39
Keyboard sealing plate .....		7-8	Unselected .....	2-72	2-39
Keyboard selector cam assembly .....		7-7	Signal bell function .....		2-39
Main shaft .....		7-5	Signal code .....	2-2	2-1
Motor .....		7-9	Signal generator mechanism, front view .....	2-13, 2-14, 2-15	2-5, 2-7
Platen .....		7-6	Signal generator, rear view		
Printing carriage .....		7-4	Marking position .....	2-19	2-9
Selector cam-clutch .....		7-6	Spacing position .....	2-17	2-8
Selector magnet assembly ...		7-7	Stop position .....	2-16	2-8
Selector mechanism .....		7-6	Signaling code .....		2-1
Signal generator .....		7-7	Spacing .....		2-25, 2-34
Space bar .....		7-8	Spacing and spacing suppression mechanism .....	2-52	2-28
Type box .....		7-3	Spacing cutout mechanism ...	2-53	2-29
Type box carriage .....		7-4	Spacing drum drive mechanism.	2-51	2-27
Upper draw wire rope .....		7-5	Spacing function .....		2-34
Repeat mechanism .....	2-25	2-10	Spacing suppression .....		2-25
Replacement of lamps .....		5-1	Spare parts boxes		
Report of failure .....		x	Weights and dimensions ....	8-1	8-2
Resuscitation notice .....		xi			
Ribbon mechanism .....		2-27			
Left side .....	2-54	2-29			
Left top view .....	2-55	2-29			
Ribbon reversing mechanism ..	2-56	2-29			
Right side mechanism .....	2-46	2-22			
Routine check chart .....	5-1	5-1			

SUBJECT	FIGURE OR TABLE	PAGE	SUBJECT	FIGURE OR TABLE	PAGE
Speed setting .....		4-3	Selector lever .....	7-36	7-45
Spring tensions			Selector push bar .....	7-36	7-45
Automatic Typewriter .....		7-40	Shift linkage .....	7-68	7-76
Automatic CR-LF bell			Shift slide drive linkage ..	7-57	7-65
crank .....	7-59	7-67	Spacing clutch trip lever ..	7-44	7-53
Breaker slide bail .....	7-51	7-59	Spacing lock lever .....	7-39	7-48
Carriage return .....	7-61	7-69	Spacing pawl .....	7-59	7-67
Carriage return latch bail ..	7-62	7-70	Spacing pawl release link ..	7-61	7-69
Carriage return lever .....	7-63	7-71	Spacing suppression bail ..	7-77	7-84
Clutch shoe .....	7-48	7-56	Spacing trip lever .....	7-54	7-62
Clutch shoe lever .....	7-48	7-56	Spacing trip lever bail ....	7-54	7-62
Code bar clutch cam			Stop arm yield .....	7-40	7-49
follower .....	7-42	7-51	Transfer bail .....	7-66	7-74
Code bar clutch latch lever ..	7-41	7-50	Transfer lever .....	7-35	7-44
Common transfer lever ...	7-35	7-44	Transfer slide .....	7-64	7-72
Drive linkage slide pawl ..	7-66	7-74	Trip shaft lever .....	7-41	7-50
Function bar .....	7-74	7-82	Type pallet .....	7-70	7-78
Function lever .....	7-74	7-82	Vertical positioning lever ..	7-51	7-59
Function pawl .....	7-74	7-82	Vertical positioning lock		
Horizontal positioning lock			lever .....	7-53	7-61
lever .....	7-51	7-59	Keyboard .....		7-10
Keyboard lock lever .....	7-64	7-72	Break bail .....	7-5	7-14
Line feed bar bell crank ..	7-75	7-83	Clutch throwout bail .....	7-9	7-18
Line feed bar release lever ..	7-75	7-83	Clutch throwout pawl ....	7-9	7-18
Line feed stripper bail ....	7-78	7-85	Clutch stop lever .....	7-8	7-17
Lower wire rope pulley bail ..	7-60	7-68	Clutch trip bar .....	7-15	7-24
Marking lock lever .....	7-33	7-42	Code bar .....	7-15	7-24
Paper finger .....	7-81	7-88	Code lever .....	7-13	7-22
Paper pressure bail .....	7-81	7-88	Code lever bail .....	7-14	7-23
Paper straightener lever ..	7-80	7-87	Code lever bail latch lever ..	7-13	7-22
Platen detent bail .....	7-75	7-83	Contact box .....	7-10	7-19
Pressure roller lever .....	7-81	7-88	Contact latch pawl .....	7-20	7-29
Printing hammer bail ....	7-69	7-77	Contact pawl .....	7-20	7-29
Printing hammer operating			Detent toggle lever .....	7-5	7-14
bail .....	7-69	7-77	Eccentric follower .....	7-11	7-20
Printing hammer operating			Flutter lever .....	7-6	7-15
bail latch .....	7-69	7-77	Intermediate lever .....	7-3	7-12
Printing hammer plunger ..	7-69	7-77	Local line feed trip link ..	7-24	7-33
Push bar reset bail .....	7-37	7-46	Lock plunger arm .....	7-26	7-35
Reversing slide detent ...	7-56	7-64	Locking bail .....	7-1	7-10
Ribbon feed lever .....	7-72	7-80	Margin indicator .....	7-30	7-39
Ribbon lever .....	7-72	7-80	Non-repeat .....	7-13	7-22
Ribbon ratchet wheel			Repeat slide .....	7-12	7-21
friction .....	7-72	7-80	Reset bail .....	7-12	7-21
Ribbon reverse detent lever ..	7-71	7-79	Reset bail latch .....	7-12	7-21
Selector armature—final ..	7-31	7-40	Selector lever .....	7-1	7-10
Selector armature —			Time delay ratchet wheel		
preliminary .....	7-31	7-40	tension .....	7-19	7-28
Selector clutch latch lever ..	7-40	7-49	Transfer lever .....	7-2	7-11
Selector clutch operating			Miscellaneous		
bail .....	7-39	7-48	Armature .....	7-91	7-97

## TT-47/UG, TT-48/UG, TT-69/UG, TT-70/UG

SUBJECT	FIGURE OR TABLE	PAGE	SUBJECT	FIGURE OR TABLE	PAGE
Centrifugal mechanism . . .	7-86	7-92	Gaining or losing a pulse . . . . .		7-2
Governor brush . . . . .	7-89	7-95	Garbling . . . . .		7-2
Intermediate lever . . . . .	7-90	7-96	Intermittent errors . . . . .		7-2
Start armature . . . . .	7-90	7-96	Irregular motor speed . . . . .		7-1
Stop armature . . . . .	7-90	7-96	Motor does not start . . . . .		7-1
Start position . . . . .		2-45	Motor does not stop . . . . .		7-1
Starting procedure . . . . .		4-3	No signal from keyboard . . . . .		7-1
Stop position . . . . .		2-44, 2-45	Ribbon fails to feed or reverse . . . . .		7-3
Stop slide positioning . . . . .	2-48	2-24	Short on margin . . . . .		7-1
Summary of operation . . . . .		4-4	Spacing failure or multiple spacing . . . . .		7-2
Symbol designations, derivation of . . . . .		7-1	Trouble shooting chart . . . . .	7-4	7-141
Symptoms of fuse failure . . . . .	5-2	5-2	Type box and type box carriage Positioning . . . . .		2-17 2-19
Synchronous motor . . . . .		1-3	Type box arrangement, viewed from front of Automatic Typewriter . . . . .	2-43	2-20
System pictorial diagram . . . . .	3-4	3-5	Typical function box mechanism, Selected . . . . .	2-62	2-32
System trouble shooting chart . . . . .	7-4	7-141	Unselected . . . . .	2-61	2-32
<b>T</b>			<b>U</b>		
Tables			Unpacking the equipment . . . . .		3-1
List of . . . . .		viii	Unshift on space . . . . .		2-34
Parts and spare parts . . . . .	8-4	8-4	Unshift on space function mechanism, disabled position . . . . .	2-66	2-34
Winding data . . . . .	7-3	7-100	<b>W</b>		
Teletypewriter complete . . . . .	1-1	1-0	Warnings—high voltage . . . . .		xi
Theory of operation . . . . .		2-1	Weight of equipment . . . . .		1-11
Automatic Typewriter . . . . .		2-12	Weights— and dimensions of spare parts boxes . . . . .	8-1	8-2
Keyboard . . . . .		2-1	and over-all dimensions . . . . .	1-1	1-12
Motors . . . . .		2-40	Winding data . . . . .	7-3	7-100
Power Distribution Panel . . . . .		2-42	Wiring Diagrams Schematic, TT-47/UG, TT-48/UG, TT-69/UG, and TT-70/UG . . . . .	7-136	7-143
Tilting arrangement . . . . .	1-11	1-9	TT-47/UG, TT-48/UG, TT-69/UG, and TT-70/UG . . . . .	7-137	7-145
Time delay mechanism . . . . .	2-30, 2-31, 2-32	2-11, 2-12			
Tools . . . . .	7-93	7-99			
Trip mechanism for function and type box clutches . . . . .	2-45	2-21			
Trouble shooting . . . . .		7-1			
Failure on carriage return . . . . .		7-2			
Failure on letters-figures shift . . . . .		7-2			
Failure on line feed . . . . .		7-2			
Failure on signal bell . . . . .		7-3			
Failure to position . . . . .		7-3			
Failure to print . . . . .		7-3			