

NAVSHIPS 92733(A)

★

TECHNICAL MANUAL

for

TELETYPEWRITER
DISTRIBUTOR-TRANSMITTERS
TT-187/UG and TT-187A/UG

TELETYPE CORPORATION
SKOKIE, ILLINOIS

DEPARTMENT OF THE NAVY
BUREAU OF SHIPS

Contract: NObsr 85475

★

Approved by BuShips: 3 April 1962

© 1962 BY TELETYPE CORPORATION. ALL RIGHTS RESERVED.

PERMISSION IS HEREBY GRANTED TO UNITED STATES GOVERNMENT TO REPRODUCE
THIS PUBLICATION OR ANY PORTION THEREOF FOR GOVERNMENTAL PURPOSES ONLY.

LIST OF EFFECTIVE PAGES

PAGE NUMBERS	CHANGE IN EFFECT
Title Page	Original
ii to vii	Original
1-0 to 1-6	Original
2-1 to 2-3	Original
2-4 Blank	Original
3-1 to 3-2	Original
4-1 to 4-13	Original

PAGE NUMBERS	CHANGE IN EFFECT
5-0 to 5-15	Original
5-16 Blank	Original
6-1 to 6-41	Original
7-0 to 7-20	Original
i-1 to i-5	Original
i-6 Blank	Original



DEPARTMENT OF THE NAVY
BUREAU OF SHIPS
WASHINGTON 25, D. C.

IN REPLY REFER TO
Code 242-100

From: Chief, Bureau of Ships
To: All Activities concerned with the Installation, Operation,
and Maintenance of the Subject Equipment
Subj: Technical Manual for Teletypewriter Distributor-Transmitters
TT-187/UG and TT-187A/UG, NAVSHIPS 92733(A)

1. This is the Technical Manual for the subject equipment and is in effect upon receipt. It supersedes NAVSHIPS 92733. Upon receipt hereof, NAVSHIPS 92733 shall be destroyed.
2. When superseded by a later edition, this publication shall be destroyed.
3. Extracts from this publication may be made to facilitate the preparation of other Department of Defense publications.
4. Errors found in this publication (other than obvious typographical errors), which have not been corrected by means of Temporary Corrections or Permanent Changes should be reported. Such reports should include the complete title of the publication and the publication number (short title); identify the page and line or figure and location of the error; and be forwarded to the Publications Section of the Bureau of Ships.
5. All Navy requests for Bureau of Ships electronic publications should be directed to the Naval Supply Depot, 5801 Tabor Avenue, Philadelphia, Pennsylvania.

R. K. JAMES
Chief of Bureau

RECORD OF CORRECTIONS MADE

CHANGE NO.	DATE	FIELD CHANGE NO.	SIGNATURE
T-1	31 Jan 64	NAVSHIP 92733(A)	MM [Signature]

TABLE OF CONTENTS

Paragraph	Page	Paragraph	Page
SECTION 1 — GENERAL INFORMATION		SECTION 3 — OPERATOR'S SECTION	
1-1.	1-1	3-1.	3-1
1-2.	1-1	3-2.	3-1
1-3.	1-2	3-3.	3-1
a.	1-2	3-4.	3-1
b.	1-2	a.	3-1
c.	1-3	b.	3-1
(1)	1-3	c.	3-1
(2)	1-3	3-5.	3-2
(3)	1-3	a.	3-2
d.	1-3	b.	3-2
(1)	1-3	c.	3-2
(2)	1-3	d.	3-2
1-4.	1-4	3-6.	3-2
a.	1-4	3-7.	3-2
b.	1-4	3-8.	3-2
c.	1-4		
d.	1-4	SECTION 4 — THEORY OF OPERATION	
e.	1-4	4-1.	4-1
f.	1-4	4-2.	4-1
g.	1-4	4-3.	4-1
h.	1-6	a.	4-1
(1)	1-6	b.	4-1
(2)	1-6	c.	4-3
(3)	1-6	d.	4-7
(4)	1-6	(1)	4-8
		(2)	4-8
		(3)	4-8
		(4)	4-10
		(5)	4-10
		e.	4-10
		f.	4-11
		g.	4-12
		4-4.	4-12
		4-5.	4-12
		4-6.	4-13
		SECTION 5 — TROUBLE SHOOTING AND PREVENTIVE MAINTENANCE	
		5-1.	5-1
		5-2.	5-1
		5-3.	5-2
		5-4.	5-2
		a.	5-2
		b.	5-4
		5-5.	5-5
SECTION 2 — INSTALLATION			
2-1.	2-1		
2-2.	2-1		
2-3.	2-1		
2-4.	2-1		
(1)	2-1		
(2)	2-1		
2-5.	2-2		
a.	2-2		
b.	2-2		
c.	2-2		
d.	2-2		
2-6.	2-3		
2-7.	2-3		
2-8.	2-3		
2-9.	2-3		

Paragraph	Page	Paragraph	Page
SECTION 6 — SERVICE AND REPAIR			
6-1. Failure Report	6-1	(1) Adjustment Sequence	6-3
6-2. General	6-1	(2) Illustration Orientation	6-3
6-3. Removal and Repair	6-1	(3) Data Furnished	6-4
a. General	6-1	(4) Tools	6-4
b. Cover	6-2	(5) Removal of Mechanisms	6-4
c. Motor	6-2	(6) Electrical Contacts	6-4
(1) TT-187/UG	6-2	(7) Clutches	6-4
(2) TT-187A/UG	6-2	(8) Manual Operation	6-4
d. Distributor-Transmitter	6-2	(9) Thermal Cutout Switch	6-4
(1) Cover Plate	6-2	b. Component Adjustment Sequence	6-4
(2) Top Plate	6-2	(1) Distributor-Transmitter	6-4
(3) Tape Guide Plate	6-2	(2) Base	6-4
(4) Rear Plate Assembly	6-2	(3) Motor	6-4
(5) Center Plate Mechanism	6-2	(4) Cover	6-4
(6) Main Shaft	6-3	c. Final Test	6-4
(7) Contact Box Assembly	6-3	6-5. Wiring Diagrams	6-4
(8) Front Plate Mechanism	6-3		
e. Base	6-3	SECTION 7 — PARTS LIST.	
(1) TT-187/UG	6-3	7-1. Introduction	7-1
(2) TT-187A/UG	6-3	7-2. List of Major Components	7-1
6-4. Adjustments	6-3	7-3. Maintenance Parts List	7-1
a. General	6-3	7-4. List of Manufacturers	7-1
		7-5. Notes	7-1

LIST OF ILLUSTRATIONS

Figure	Page	Figure	Page
SECTION 1 — GENERAL INFORMATION			
1-1. Distributor-Transmitter TT-187/UG	1-0	4-5. Start-Stop Lever and Tight Tape Switch Mechanism	4-4
1-2. Distributor-Transmitter TT-187A/UG	1-0	4-6. Control Mechanism	4-5
1-3. Distributor-Transmitter TT-187/UG, Cover and Cover Plates Removed	1-2	4-7. Front Plate Mechanism (Rear View)	4-6
1-4. Distributor-Transmitter TT- 187A/UG, Cover Removed	1-4	4-8. Clutch, Disengaged	4-6
		4-9. Clutch, Engaged	4-6
		4-10. Main Bail and Drive Arm Mechanism	4-7
		4-11. Tape Lid Mechanism (Bottom View)	4-8
		4-12. Free Wheeling and Tape-Out Mechanism	4-9
		4-13. Tape Feed Mechanism	4-9
		4-14. Sensing, Locking and Transfer Lever Mechanism	4-10
		4-15. Signal Generator Mechanism	4-11
		4-16. Transfer Bail Stabilizer	4-12
		4-17. A.C. Synchronous Motor for TT- 187/UG or TT-187A/UG, Schematic Wiring Diagram	4-12
		SECTION 5 — TROUBLE SHOOTING AND PREVENTIVE MAINTENANCE	
		5-1. Tools	5-0
		5-2. Motor and Base Lubrication	5-7
		5-3. Tape Guide Plate	5-8
		5-4. Signal Contact Assembly	5-9
		5-5. Clutch Trip Mechanism	5-10
		5-6. Main Shaft and Oil Reservoir	5-11
		5-7. Center Plate Mechanism	5-12
SECTION 2 — INSTALLATION			
2-1. Outline and Mounting Dimensions	2-2		
2-2. Base Wiring	2-3		
SECTION 3 — OPERATOR'S SECTION			
3-1. Path of Tape in Distributor- Transmitter	3-1		
SECTION 4 — THEORY OF OPERATION			
4-1. Block Diagram	4-2		
4-2. Signal Code	4-3		
4-3. Code Representations of the Letters "R" and "Y"	4-3		
4-4. Cam-Clutch Main Shaft	4-4		

Figure	Page	Figure	Page
5-8.	Front Plate, Sensing and Feed Mechanisms	5-13	
5-9.	Transfer Mechanism	5-14	
5-10.	Cover and Base Lubrication	5-15	
SECTION 6 — SERVICE AND REPAIR			
6-1.	Covers	6-5	
6-2.	Base Assemblies	6-6	
6-3.	Miniaturized Base Assembly, TT-187A/UG	6-7	
6-4.	Intermediate Gear Mechanism	6-8	
6-5.	A.C. Synchronous Motor, TT-187/UG	6-9	
6-6.	Miniaturized A.C. Synchronous Motor, TT-187A/UG	6-10	
6-7.	Distributor-Transmitter, Top and Cover Plates	6-11	
6-8.	Distributor-Transmitter, Tape Guide Plate	6-12	
6-9.	Distributor-Transmitter, Rear Plate Mechanism	6-13	
6-10.	Distributor-Transmitter, Clutch Trip Magnet	6-14	
6-11.	Distributor-Transmitter, Center Plate Mechanism	6-15	
6-12.	Distributor-Transmitter, Front Plate Mechanism	6-16	
6-13.	Distributor-Transmitter, Front Plate Mechanism	6-17	
6-14.	Distributor-Transmitter, Cam-Clutch Main Shaft Mechanism	6-18	
6-15.	Distributor-Transmitter, Contact Box Assembly	6-19	
6-16.	through ADJUSTMENTS		
6-34.			
6-16.	Cover Assemblies	6-20	
6-17.	Clutch Mechanism	6-21	
6-18.	Clutch Trip Mechanism	6-22	
6-19.	Tape Guide Plate	6-23	
6-20.	Tape Lid Assembly	6-24	
6-21.	Tape Guide Plate Mounting	6-25	
6-22.	Top Plate and Cover Plate Mounting	6-26	
6-23.	Tape-Out Contact Assembly	6-27	
6-24.	Tape-Out Sensing Pin	6-28	
6-25.	Start-Stop Switch Assembly	6-29	
6-26.	Main Bail Assembly	6-30	
6-27.	Code Sensing Fingers	6-31	
6-28.	Feed Pawl Mechanism and Transfer Lever Spring	6-32	
6-29.	Main Bail Trip Assembly	6-33	
6-30.	Transfer Bail Stabilizer	6-34	
6-31.	Signal Generator	6-35	
6-32.	Clutch Trip Magnet Assembly	6-36	
6-33.	Cover Plate Detent and TT-187A/UG Line Shunt Switch	6-37	
6-34.	Intermediate Gears	6-38	
6-35.	Main Power Distribution Diagram	6-39	
6-36.	TT-187/UG or TT-187A/UG Actual Wiring Diagram	6-40	
6-37.	TT-187/UG or TT-187A/UG Schematic Wiring Diagram	6-41	

LIST OF TABLES

Table	Page	Table	Page
SECTION 1 — GENERAL INFORMATION			
1-1.	Distributor-Transmitter Components	1-1	
1-2.	Equipment Supplied	1-5	
1-3.	Shipping Data	1-5	
1-4.	Equipment Required but not Supplied	1-6	
SECTION 4 — THEORY OF OPERATION			
4-1.	Interoperation of 7.42 and 7.00 Transmission Pattern	4-2	
SECTION 5 — TROUBLE SHOOTING AND PREVENTIVE MAINTENANCE			
5-1.	List of Tools	5-1	
5-2.	Routine Maintenance Check Chart	5-2	
5-3.	Trouble Shooting Chart	5-3	
SECTION 6 — SERVICE AND REPAIR			
6-1.	Winding Data	6-39	
SECTION 7 — PARTS LIST.			
7-1.	Distributor-Transmitter, List of Major Components	7-0	
7-2.	Distributor-Transmitter, List of Maintenance Parts	7-2	
7-3.	List of Manufacturers	7-20	

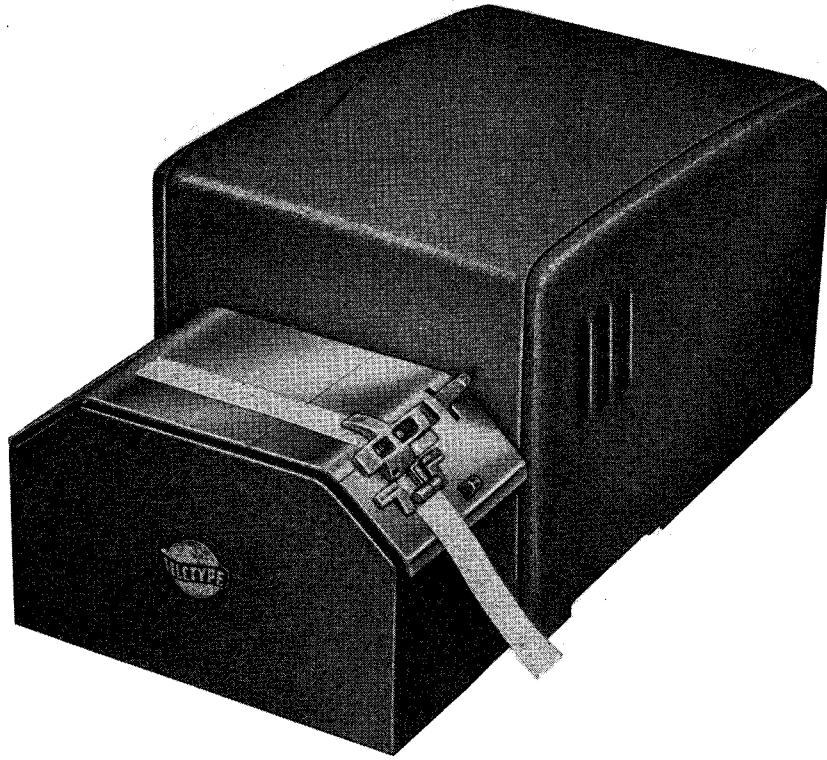

Figure 1-1. Distributor-Transmitter TT-187/UG



Figure 1-2. Distributor-Transmitter TT-187A/UG

SECTION 1
GENERAL INFORMATION

1-1. SCOPE OF INSTRUCTION BOOK.

This instruction book describes Distributor-Transmitters TT-187/UG and TT-187A/UG, illustrated in figures 1-1 and 1-2. It includes information concerning their installation, adjustment, operation and maintenance. Any references to TT-187/UG apply equally to TT-187A/UG unless indicated as peculiar to TT-187/UG. Specific references to TT-187A/UG have been made only to the extent needed for clarity.

1-2. PURPOSE OF THE EQUIPMENT.

a. The distributor-transmitter is used to read code combinations perforated in tape and translate these combinations into electrical impulses in the form of a Baudot code signal. When connected by radio or wire telegraph channels with teletypewriter equipment in other ships or stations, the distributor-transmitter originates signal transmission. It is a send only mechanism not equipped to sense the electrical characteristics of incoming messages on the signal line.

b. The Distributor-Transmitter TT-187/UG is a standard sized unit equipped with a self-contained motor mounted on a base which also supports the transmitting mechanism. The set is housed in a cabinet type cover.

c. The Distributor-Transmitter TT-187A/UG is a miniaturized model of the standard distributor-transmitter. It features light weight, compact components,

including a self-contained motor, a miniaturized base, and a small cabinet or cover.

d. The components comprising distributor-transmitters described herein are as shown in table 1-1.

e. Except for differences in application of the equipment relative to size and weight, there are no functional differences between the two distributor-transmitters and their components. Both sets are wired for 110 V a.c. operation. Signal line operation may be on either 0.060 or 0.020 ampere d.c. line current.

f. Signaling between the distributor-transmitter and the distant station is accomplished electrically by use of the five-unit stop-start permutation code and utilizes the 7.42 unit transmission pattern. On this signal, the nominal operating speed is 368 operations per minute (o.p.m.), which is 60 words per minute speed (w.p.m.). The speed may be increased by changing gears, not supplied with the equipment, but available as optional components, to 460 or 600 o.p.m., or operating speeds of 75 or 100 w.p.m.

g. There is no provision in this equipment for the reception of incoming messages. External controls are required to stop transmission when the signal line is to be used for signals generated at another station.

h. Distributor-Transmitters TT-187A/UG are equipped with an automatic line shunting switch designed to close the signal circuit when the transmitting

TABLE 1-1. DISTRIBUTOR-TRANSMITTER COMPONENTS

COMPONENTS	DISTRIBUTOR-TRANSMITTER		
	MANUFACTURER'S DESIGNATION	TT-187/UG	TT-187A/UG
COVER COVER, MINIATURIZED	LXDC200 LXDC201	X	X
BASE BASE, MINIATURIZED	LXDB1 LXDB4	X	X
MOTOR, A.C. MOTOR, A.C.	LMU3 LMU19	X	X
DISTRIBUTOR-TRANSMITTER DISTRIBUTOR-TRANSMITTER	LXD1 LXD4	X	X
GEAR SET - 60 W. P. M.	156658	X	X
GEAR SET - 75 W. P. M.	156659	X	X
GEAR SET - 100 W. P. M.	156728	X	X

NAVSHIP
92733(A) CHANGE
T-1

"SEE T-1" FOR REF. TO FOLLOWING PARAGRAPH.

"SEE T-1" FOR REF. TO
TABLE 1-1

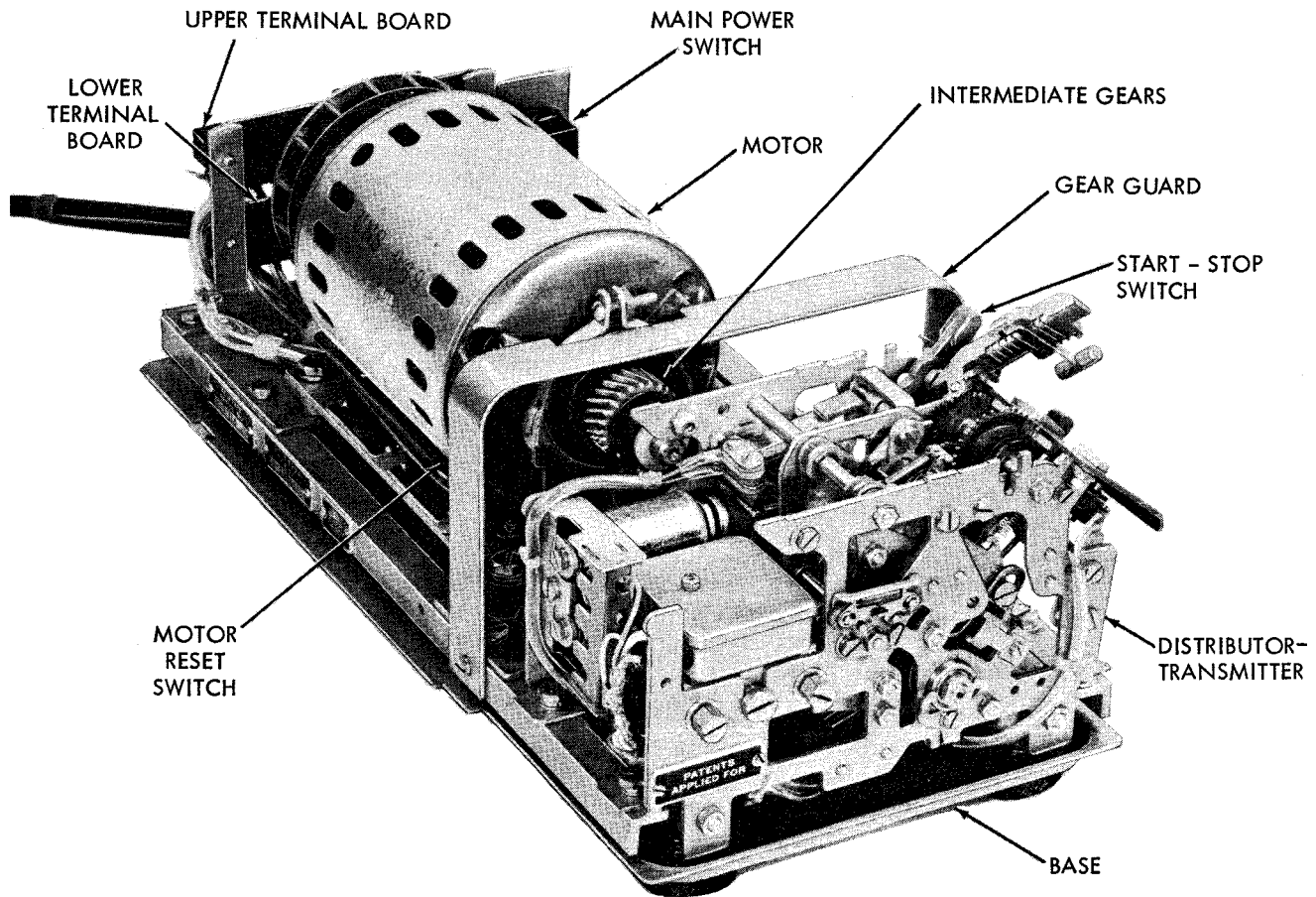

Figure 1-3. Distributor-Transmitter TT-187/UG, Cover and Cover Plates Removed

mechanism is removed from the base. Design of the equipment is such that either set may be turned off (but not disconnected from the signal circuit) without interrupting the signal circuit through the equipment.

1-3. DESCRIPTION OF MAJOR COMPONENTS.

a. COVER (TT-187/UG) OR MINIATURIZED COVER (TT-187A/UG). (See figure 1-4.)

(1) A two-piece sheet metal cover encloses the top and sides of each distributor-transmitter. The front portion of the cover is identical on all sets. It consists of a three sided panel slipped horizontally over the transmitting mechanism and the front portion of the base. Detent slots in the sides of the panel retain this portion of the cover to the distributor-transmitter. The transmitting mechanism is covered by three cover plates which are a part of the distributor-transmitter.

(2) TT-187/UG - A cover encloses the rear of the base and the gear guard, protecting the motor, intermediate gear mechanism and electrical connections and reducing operating noise. The cover clips

to the base panel when set vertically over the set. Provision is made at the rear of the cover for access to the main power switch and for entry for power and signal cords.

(3) TT-187A/UG (figure 1-4). - A miniaturized cover encloses the rear of the base and the gear guard, protecting the motor, intermediate gear mechanism and electrical connections and reducing operating noise. The cover is positioned vertically over the rear of the set to engage three spring clips mounted on the sides and rear of the base. Provision is made at the rear of the cover for access to the main power switch and for entry for power and signal cords.

b. BASE (TT-187/UG) OR MINIATURIZED BASE (TT-187A/UG). (See figures 1-3 and 1-4.)

(1) A flat metal stamping serves as a stand, drip pan and mounting support for the distributor-transmitter. Four triangular telephone type mounting feet are attached to the bottom of the base plate. Supports and brackets for operating mechanisms are suspended above the base plate on three rubber shock mounts

designed to reduce operating noise and vibration. Mounting for the distributor-transmitter is provided at the front of the base. The motor, intermediate gear mechanism and electrical connections are mounted at the rear of the base. A sheet metal gear guard covers the intermediate gear mechanism. Two terminal boards for interconnection of the components and external cabling are mounted at the rear of the base. The main power switch mounted at the rear of the base is accessible through an aperture at the rear of the cover.

(2) TT-187/UG (figure 1-3). — This distributor-transmitter is furnished with a full size base equipped as described in paragraph 1-3b(1). This base is designed for mounting the full size cover and large motor and is therefore not interchangeable with the base used on miniaturized equipment.

(3) TT-187A/UG (figure 1-4). — This distributor-transmitter is furnished with a miniaturized base equipped as described in paragraph 1-3b(1). In addition, this base features a line shunting switch (figure 1-4) to close the signal line when the distributor-transmitter is removed from the base. The base is designed for mounting the miniaturized cover and motor.

c. MOTORS. (See figures 1-3 and 1-4.)

(1) GENERAL. Each distributor-transmitter is a motor driven by a self-contained 115 V a.c. synchronous motor. The motor is designed to operate at 3600 r.p.m., and variations in operating speed are obtainable through changes in intermediate gear mechanisms. Power from an external power supply to the motor is controlled through a main power switch located on the base. There is a push-button type thermal switch (figure 1-3) on the motor as protection against overload. The standard motor (TT-187/UG) and the miniaturized motor are operationally similar but differ in size and weight. They are not interchangeable.

(2) TT-187/UG (figure 1-3). — The motor furnished with this distributor-transmitter 1/20 h.p., 115 V, 60 cycle a.c. wound stator, two pole, single phase, capacitor start synchronous motor. A combination handwheel and fan is mounted on one end of the motor shaft. A motor-starting relay and capacitor, together with the thermal cutout switch are mounted in a compartment on the underside of the motor. The thermal cutout switch (manually reset) serves to protect the motor windings from excessive heating. The motor proper is supported by a cradle to which it is held by straps at each end. Resilient mounts on the hubs of the motor end bells reduce transmission of vibration to the base.

(3) TT-187A/UG (figure 1-4). — The motor furnished with this distributor-transmitter is a 1/40 h.p., 115 V, 60 cycle a.c. wound stator, two pole single phase, capacitor start synchronous motor. A motor-starting relay and capacitor, together with the thermal cutout switch, are mounted beneath the cradle which supports the motor. The motor is held to the cradle by straps on each end of the shaft. Resilient

mounts on the hubs of the motor end bells reduce transmission of vibration to the base. This is a compact, light-weight, motor design. There is no external fan to ventilate the motor, but a hood bracketed around the motor deflects air circulated by ventilating vanes on the armature through vent holes in the distributor-transmitter cover.

"SEE T-1" FOR REF TO FOLLOWING AC MOTOR
(Governor)
PD-18/10

d. DISTRIBUTOR-TRANSMITTER. (See figures 1-3 and 1-4.)

(1) Different distributor-transmitters are used in TT-187/UG and TT-187A/UG to accommodate the equipment to differences between the standard and the miniaturized base. The operating features of the two distributor-transmitters are identical.

(2) Each distributor-transmitter is a mechanical tape reader designed to convert coded messages stored on standard five-level chadless or fully perforated tapes to signaling code combinations for transmission in a telegraph channel. A main shaft powered by the motor through intermediate gear connections operates a cam-clutch assembly. The cam-clutch, through a main bail, drives a transfer mechanism and a signal generating mechanism and a tape feed wheel. The clutch is released by a clutch trip magnet assembly.

(3) Distributor-transmitter operating controls which are wired in series with the clutch trip magnets include a start-stop switch and a tape-out switch. The start-stop switch incorporates tight tape, on-off, and free-wheeling tape feed features. Electrical requirements for operation of distributor-transmitter controls are supplied through cable connections to terminal boards located on the base. The cable terminates in a 36-point connector (figure 1-4) mounted on the distributor-transmitter, mating with a similar connector on the base, in the case of Distributor-Transmitters TT-187A/UG.

(4) Electrical connections to the signal generator are made to the external signal line through the base. The equipment is designed to operate on either 0.060 or 0.020 ampere circuits. Normal operation is on a neutral circuit, but the equipment is wired for easy conversion to polar operation. Transmission speed can be 368, 400 or 600 o.p.m. (60, 75, or 100 w.p.m.) depending upon optional gear ratios selected in the intermediate gear mechanism.

(5) TT-187/UG (figure 1-3). — Distributor-Transmitters TT-187/UG are designed to extend the cable connections from the distributor-transmitter directly to the upper terminal board of the base. There are no connectors or receptacles on the distributor-transmitter and base, respectively. The distributor-transmitter has no provision for activating a line shunt switch.

(6) TT-187A/UG (figure 1-4). — Distributor-Transmitters TT-187A/UG are designed for mating connector and receptacle connections between the distributor-transmitter and base. Distributor-transmitter cabling terminates in a 36-point connector

TABLE 1-2. EQUIPMENT SUPPLIED

QTY PER EQPMT.	NAME OF UNIT	MFGR'S DESIGNATION	NAVY DESIGNATION		OVER-ALL DIMENSIONS (IN INCHES)			VOL. CU. FT.	WT. LBS.
					HEIGHT	WIDTH	DEPTH		
	DISTRIBUTOR-TRANSMITTER		TT-187/UG	TT-187A/UG					
1	COVER	LXDC200	X		7	8	11-1/4	2.8	5
1	COVER, MINIA-TURIZED	LXDC201		X	5	7-1/2	5-3/4	1.2	5
1	BASE	LXDB1	X		6	8	15	0.4	7
1	BASE, MINIA-TURIZED	LXDB4		X	5-1/4	7-1/2	9-3/8	0.20	4
1	MOTOR, AC	LMU3	X		5-3/4	8-1/2	4	0.11	9
1	MOTOR, AC	LMU19		X	5-1/4	5-1/2	4-1/2	0.07	4
1	DISTRIBUTOR-TRANSMITTER	LXD1	X		4-1/2	7-1/8	4-1/2	0.07	6
1	DISTRIBUTOR-TRANSMITTER	LXD4		X	4-1/2	7-1/8	4-1/2	0.07	6
1	SET OF GEARS:								
	* 60 W. P. M.	156658	X	X					
	* 75 W. P. M.	156659	X	X					
	*100 W. P. M.	156728	X	X					
	* - Optional								
TOTAL									

TABLE 1-3. SHIPPING DATA (DOMESTIC PACK)

SHIPPING BOX NO.	CONTENTS		OVER-ALL DIMENSIONS (IN INCHES)			VOL. CU. FT.	WT. LBS.
		MFGR'S DESIGNATION	HEIGHT	WIDTH	DEPTH		
1	COVER	LXDC200	8-3/8	8-1/4	11-5/8	0.4	7
		or LXDC201	6-1/2	6-1/8	8	0.2	5
1	BASE	LXDB1	6-1/2	7-3/4	15	0.4	7
		or LXDB4	7-1/4	8-1/2	10-1/2	0.4	7
1	MOTOR, A. C.	LMU3	7-7/8	5-7/8	10-3/4	0.3	9
		or LMU19	6-1/2	5-5/8	7-1/2	0.2	5
1	DISTRIBUTOR-TRANSMITTER	LXD1	6-1/4	5	8-5/8	0.2	5
		or LXD4	6-1/4	5	8-5/8	0.2	5
2	CONSOLIDATED PACKAGE, Gears, Instruction Books		4	11	10	0.3	4

- (2) Distributor-Transmitter TT-187A/UG.
- (a) Crated 64 lbs.
 - (b) Uncrated 24 lbs.

NOTE

Volume and weight data for equipment furnished are tabulated in tables 1-2 and 1-3. Equipment required but not supplied is listed in table 1-4.

h. ELECTRICAL CHARACTERISTICS.

(1) SIGNAL. — Signal current applied at the distributor-transmitter signal generator may be either 0.060 or 0.020 amperes on-off direct current applied from an external source. Input signal characteristics are immaterial, since the equipment is designed for transmitting service only. It is necessary, however, that a closed line condition (marking condition) be maintained throughout the signal circuit while the distributor-transmitter is in operation. As furnished, the equipment is wired for operation on a neutral signal circuit. It may be adapted for polar operation.

(2) FREQUENCY CONTROL. — The signal frequency depends on the use of a 60-cycle synchronous motor. Frequency of the telegraph output signal is expressed in maximum dot cycles (one cycle is one current impulse followed by one no-current impulse) per second and varies with the intended operating speed as follows: (SEE TABLE 4-1)

- 60 w.p.m. — 22.8 cycles
- 75 w.p.m. — 28.5 cycles
- 100 w.p.m. — 37.1 cycles

(3) OPERATING CONTROLS. — Distributor-transmitters are furnished for operation on 115 V a.c. control circuits. With the addition of external resistance, the control circuit may be operated on either 50 V d.c. or 120 V d.c.

(4) POWER SUPPLY REQUIREMENTS.

(a) A.C. MOTOR (LMU3).

Input voltage 115 volts, ±10 percent, a.c.
 Phase Single phase
 Frequency 60 cycles ±0.5 cycle
 Input current, starting 9 amps
 Running 1.85 amps
 Watts 65 watts
 Power factor No load, 23.7 percent
 Full load, 38.5 percent
 Heat dissipation 50 watts
 Horsepower 0.050 hp

(b) MINIATURIZED AC MOTOR (LMU19)

Input voltage 115 volts, ±10 percent, a.c.
 Phase Single phase
 Frequency 60 cycles, ±0.75 percent
 Input current, starting 5 amps
 Running, no load 1.05 amps
 Full load 1.25 amps
 Horsepower 0.025 hp

(c) PERMISSIBLE TEMPERATURES.

- (1) Ambient: -20°C (-4°F) to + 50°C (+122°F).
- (2) Temperature rise: Not in excess of +40°C (+104°F) above ambient.

"SEE T-1" FOR REFERENCE

SEE T-1 FOR REF. -> TABLE 1-4. EQUIPMENT REQUIRED BUT NOT SUPPLIED TO FOLLOWING PARAGRAPH.

QUANTITY PER EQUIPMENT	NAME OF UNIT
1	Set of tools as listed in Section 5, Paragraph 5-2
1	Tool Equipment TE-50-B
1	DXD Distortion Test Set TS-383B/GG OR TS-652/GG
1	NAVSHIPS 91654, Operating Instructions for DXD Distortion Test Set 383B/UG

AC MOTOR (GOVERNED)
 LMU 4 (PD-18/U)
 SEE T-1 PAGE 2

SECTION 2

INSTALLATION

2-1. GENERAL.

Distributor-Transmitters TT-187/UG and TT-187A/UG are each packed in two cardboard boxes. One of these contains the cover, motor, base and distributor-transmitter. The other contains spare parts, instruction books and sets of gears.

2-2. UNPACKING THE EQUIPMENT.

Carefully slit the cardboard cartons along the sealed edges. Avoid penetration to a depth which might scratch or mar the finish of the equipment. Lift the components from the cartons, and unwrap protective packaging materials.

2-3. BASE INSTALLATION.

a. Distributor-Transmitters TT-187/UG and TT-187A/UG are self-contained installations supported on any flat surface large enough to permit the base to rest upon its own four telephone type feet. The location should be convenient to power and signal lines. Within limits of the slack in electrical connections, either set can be positioned readily after assembly or when in operation. Sufficient room should be allowed at the rear of the set for access to the main power switch. Sufficient clearance should be allowed at the left of the set to permit air circulation. Head room should be sufficient to lift the cover from the set. Outline dimensions and installation requirements are detailed in figure 2-1.

b. Select the gear and pinion set required for the operating speed desired. Mounting hardware is packaged in a cloth bag packed with the base. Use two screws and lock washers (H402 and H403, figure 6-4) to attach the drive gear (deeply concave side forward) to the intermediate gear shaft.

c. When installing Distributor-Transmitter TT-187/UG base, install the distributor-transmitter cable beneath the front and rear plates and fasten with cable clamp, screw, washer and lock washer (H233, H218, H219 and H220, figure 6-2). Refer to figure 2-2 for cable connections on the terminal boards. Refer to figure 6-35 for a diagram of main power distribution.

2-4. POWER AND LINE CONNECTIONS.

(See figure 2-2.)

a. Lead external power, ground and signal lines to the lower terminal board from the rear of the base.

(1) T-187/UG. — Attach external cables to the projection on the rear of the base plate. Use two cable clamps, screws, washers and lock washers (H217

through H220, figure 6-2), packaged in the cloth bag packed with the base.

(2) TT-187A/UG. — Lead external cables through the adjustable cable clamp located at the rear of the base. Press the clamp retainer tightly over the cables, locking the retainer beneath the serrated edges of the clamp.

b. Connect the external ground to terminal 4 of the lower terminal board (figures 1-3 and 1-4). Connect chassis grounds (W201) between terminal 4 of the lower terminal board and the right terminal board bracket mounting screw and the rear shock mount screw. (TT-187A/UG only, attach grounds to the right shock mount screw and the front terminal board bracket mounting screw.)

CAUTION

External power and signal voltages should be off before completing electrical power connections.

c. Connect external power leads to terminals 7 and 9 of the lower terminal board. The grounded side of the external circuit should be connected to terminal 9.

d. Connect external signal leads to terminals 1 and 2 of the lower terminal board. The negative lead must be connected to terminal 1.

e. Except for slightly different physical location of the upper and lower terminal boards on the base, terminal board wiring for Distributor-Transmitter TT-187/UG or TT-187A/UG is identical. (See figure 2-2.) In wiring TT-187/UG terminal boards, lead the distributor-transmitter cable from the cable clamp around the left terminal board mounting bracket and between the upper and lower terminal boards to the number 1 terminals. In wiring TT-187A/UG terminal boards, lead the base cable in front of the front terminal board mounting bracket to the number 1 terminals.

f. Straps E203 and E204 between upper terminal board (figures 1-3 and 1-4) terminals 2 and 3 and 4 and 5 connect distributor-transmitter control circuit components in series with the clutch magnets. Power to the control circuits is supplied by jumpers between terminals 8 and 9 on the lower terminal board and terminals 1 and 6 on the upper board, respectively. The jumpers are supplied as part of cables W302 or W850.

g. In Distributor-Transmitters TT-187A/UG, terminal 3 of the lower terminal board is connected to

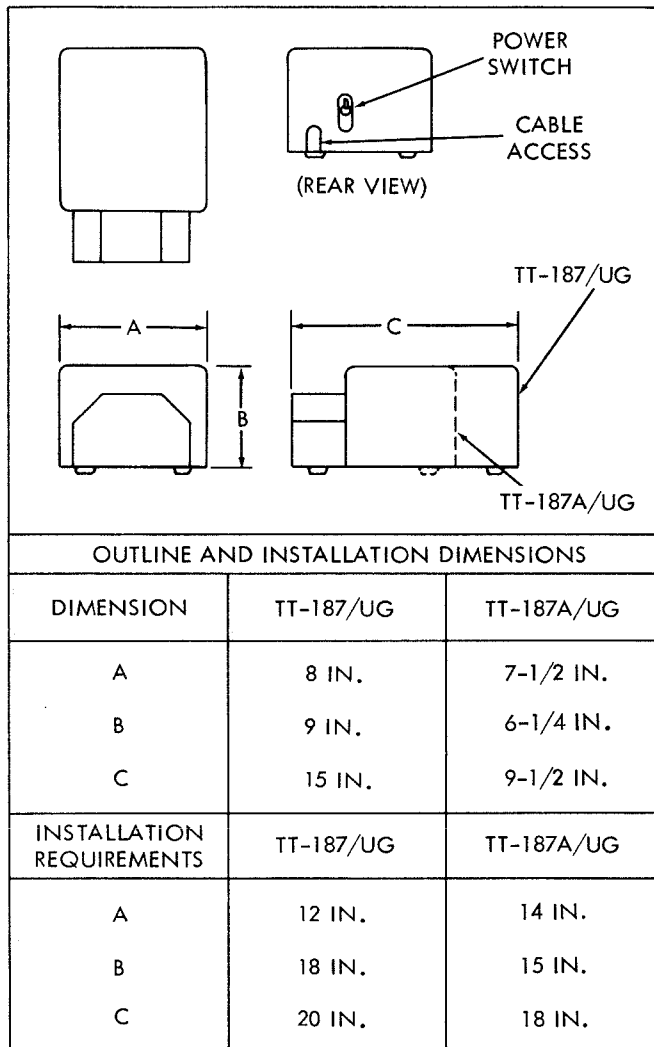

Figure 2-1. Outline and Mounting Dimensions

pin 21 of base connector P301. This connection is reserved for operation on a polar signal and is not fused when the equipment is operated on a neutral signal system.

2-5. ASSEMBLY OF EQUIPMENT.

a. MOTOR.

(1) Select the motor shaft pinion gear to match the operating speed rating of the drive gear assembled to the base (paragraph 2-3b). From the bag of parts attached to the base, remove the rubber pinion retainer and two posts. Stretch the retainer into place around the pinion gear shaft, and fasten the retainer and pinion to the motor shaft with the two posts. Mount the retainer on the end of the shaft, the pinion between motor and retainer.

(2) Remove four mounting screws and lock washers, H206 and H207 or H306 and H307, from the cloth

bag packaged with the base. Position the motor mounting bracket holes over the studs on the front and rear base plates, the pinion engaging the drive gear. Fasten the motor to the base, using four screws and lock washers.

Note

Motor mounting hardware for Distributor-Transmitters TT-187/UG and TT-187A/UG is not interchangeable.

(3) Connect two motor leads to terminals 8 and 9 of the lower terminal board. The leads are interchangeable.

(4) If motor pinion and intermediate shaft drive gear fail to mesh, check the position of the pinion on the motor shaft. Lateral engagement of the gears may be adjusted by loosening the intermediate gear mechanism mounting bracket and repositioning the bracket.

b. DISTRIBUTOR-TRANSMITTER TT-187/UG — With the distributor-transmitter cable attached to the base, there is sufficient cable slack to move the unit to its installed position across the front of the base. Position the distributor-transmitter drive gear over the intermediate gear, and locate the mounting bracket holes over three mounting holes, two in the left side bar and one in the right side bar of the base. Attach the distributor-transmitter to the base, using three screws, washers and lock washers, H201, H202 and H203, furnished in the cloth bag packaged with the base.

c. DISTRIBUTOR-TRANSMITTER TT-187A/UG.

(1) Position the distributor-transmitter mechanism across the front of the base, its connector mating with the base receptacle, and the distributor-transmitter drive gear over the intermediate gear. The line shunt switch operating screw should open the line shunt switch on the base when the receptacle and connector are half-mated. Adjust the operating screw (E901) to meet this requirement before attaching the distributor-transmitter to the base. (See figure 6-33.)

(2) Position the three mounting bracket holes over two mounting holes in the left side bar and one in the right side bar of the base. Attach the distributor-transmitter to the base, using three screws, washers and lock washers, H201, H202 and H203, furnished in the cloth bag packaged with the base.

Note

Distributor-transmitter mechanisms for Distributor-Transmitters TT-187/UG and TT-187A/UG are not interchangeable.

d. COVER.

(1) With the access hole for the main power switch at the rear, position the cover over the rear of the mechanism, enclosing the rear of the

base, the gear guard and intermediate gear mechanism and the motor. Be sure the air circulation vents are not obstructed. Push down on the cover when it is correctly positioned to latch it on the base.

(2) Slide the panel portion of the cover over the distributor-transmitter mechanism from the front, engaging the mounting plates of the mechanism with detents in the sides of the panel. The panel fits beneath the cover plates of the distributor-transmitter and is held in place by the spring effect of the side panels.

2-6. MECHANICAL CHECKING OF EQUIPMENT.

a. Make a visual check of the following before putting the equipment into operation.

- (1) Screw terminal connections.
- (2) Ground connections.
- (3) Pinion gear retainer and posts.
- (4) Motor, intermediate gear mechanism and distributor-transmitter mounting screws.
- (5) Motor reset button (red button beneath motor) depressed.
- (6) Operation of gears and clutch when equipment is cycled manually by rotating motor shaft clockwise as viewed from pinion end.

b. Check the following switches before closing the main power line to the equipment.

- (1) The power switch toggle at the rear of the cover in down position (OFF).
- (2) The start-stop (green) switch on the distributor-transmitter in its center (OFF) position.

c. Lubricate the intermediate driven gears with grease MIL-G-3278. Components are factory lubricated, except for the optional gears selected at the time of installation. If the equipment is installed after an extended period of storage, or if there has been extended delay in installation after factory packaging has been opened, check lubrication points indicated in Section 5 prior to operation.

2-7. OPERATING TESTS.

a. With external power supply on, switch the main power switch toggle up to ON position. The motor should run, driving the intermediate gear train and distributor-transmitter drive gear quietly and without excessive vibration. In the event of an obstruction in the mechanism or an overload, the thermal overload switch will interrupt the motor circuit. To reset, allow the switch to cool approximately five minutes and depress the red button located beneath the left-side of the motor.

b. Remove the set from the signal line either by external signal line shunting or by disconnecting signal leads. Insert a punched tape in the tape lid,

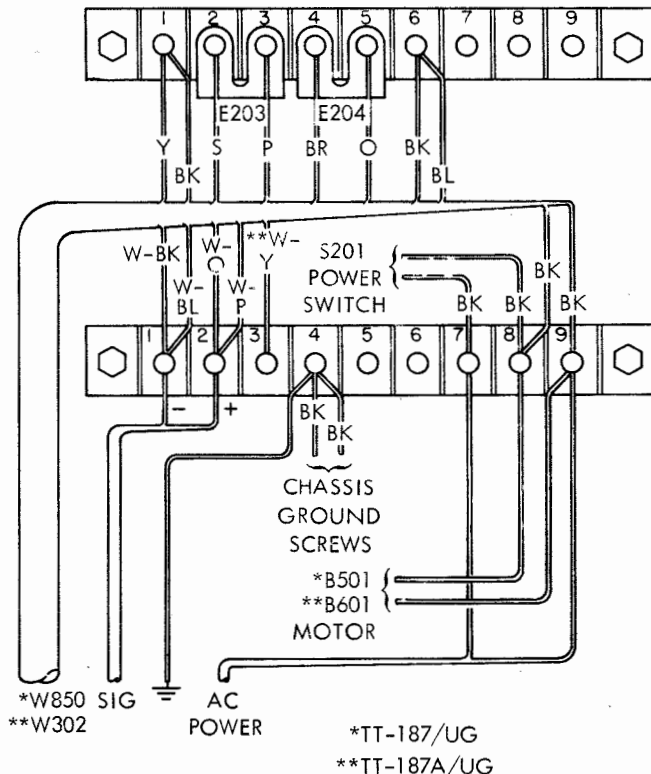

Figure 2-2. Base Wiring

set the start-stop (green) switch in its extreme left position, and check free movement of the tape through free-wheeling tape feed mechanism.

c. With tape in place under the tape lid and the tape lid latched in operating position, turn the main power toggle switch ON. Move the start-stop switch to its extreme right position (RUN). Tape should feed through the reading head steadily without tearing feed holes or code holes. The distributor-transmitter should stop automatically when the end of the tape has passed the tape-out pin.

d. Connect a signal distortion set (DXD) in the signal line to check signal transmission.

e. If irregularities in operation are observed, notify authorized maintenance personnel. (In any case of failure of a part, complete ELECTRONIC FAILURE REPORT form DD787 and forward to BuShips.)

2-8. INDICATORS AND ALARMS.

There are no alarms or indicators on the equipment. Transmission is automatically interrupted in the event of taut or tangled tape or when there is no tape in the reading head. Transmission will resume automatically when the condition is remedied.

2-9. FINAL CHECKS.

The equipment has been thoroughly tested and adjusted at the factory and should not require further adjusting. Preventive maintenance measures and adjustment procedures recommended for authorized maintenance personnel are furnished in Sections 5 and 6 of this manual.

2-10 SEE FOR REF. (OVER)

2-10 194031 MODIFICATION KIT TO
CONVERT DISTRIBUTOR - TRANSMITTER TT-187/UG,
TT-187A/UG, TT-273/UG TO 700 UNIT
CODE WITH SYNCHRONOUS PULSED TRANSMISSION.

Q. THE 194031

SEE T-1 PAGE 3

2-10 FOR REF.

SECTION 3

OPERATOR'S SECTION

3-1. INTRODUCTION.

Except for insertion of a perforated tape in the reading head and operation of two simple toggle switches, operation of Distributor-Transmitter TT-187/UG and TT-187A/UG is fully automatic. Because of the fully automatic nature of transmission once the equipment has been set up by the operator, a clear, closed signal line must be assured prior to transmission. This may be secured through associated teletypewriter send-receive equipment on the same or through auxiliary communications channels. A garbled message will be produced if the distributor-transmitter is operated while other sending apparatus on the same line is in use.

3-2. PREPARATION FOR USE.

- a. Turn the main power switch to up (ON) position.
- b. Check the condition of the external signal circuit, particularly if external line shunting, switching or selective calling equipment are incorporated in the signaling system.

3-3. OPERATING PROCEDURES.

- a. Any five-level tape 11/16 inch wide and 10-hole per inch feed, chadless or fully perforated, typed or blank, can be read by the distributor-transmitter. When tape rolled on a tape winder as it is perforated is fed into the reading head, the inner end of the tape must be fed into the tape feed mechanism first.

- b. Make certain the start-stop switch (figure 3-1) is either in the OFF (center) or FREE (left) position. Depress the red tape lid release button to raise the spring loaded tape lid. Place the tape feed perforations on the teeth of the tape feed wheel. Two code perforations appear above and three below the tape feed perforations. When tape is placed in the transmitter, the two perforation side should be toward the back of the transmitter. Hold the tape down flat, and close the tape lid manually. The code holes positioned immediately above the five sensing pins will be the character first transmitted. When printed tape is used, the position of this character can be determined by reference to the index mark scribed on the reading head six characters behind the sensing pin. The printed character immediately above the index mark corresponds to the code positioned over the sensing pins. With the stop-start switch in free wheeling position, the tape may be positioned forward or back freely to the desired character.

- c. Move the start-stop switch to its right-hand position (RUN) to begin transmission.

- d. To interrupt transmission of a message to insert an addition, correction, or new message, raise the distributor-transmitter switch to its center (OFF) position to stop transmission and tape feed. Note and/or mark the exact position of the tape with respect to the index mark on the reading head. Release the tape lid by depressing the red button. Remove the tape and insert the new tape as directed above. When the inserted addition, correction or change has been transmitted, replace the original tape either at the point at which it was removed or at the desired point following a deletion.

3-4. AUTOMATIC CONTROLS.

- a. MOTOR OVERLOAD CUTOFF. — In case of motor overload, a thermal switch (figure 1-3) located beneath the motor at the left-side of the set will interrupt the motor circuit and stop transmission. The switch must be manually reset after the cause of the overload has been determined. Press down on the red button of the overload switch.

- b. TIGHT OR TANGLED TAPE. (See figure 3-1.) — When the input tape becomes taut or tangled to the extent that its passage over the feed mechanism might be impeded, the tape elevates the tight tape lever on the tape lid. This interrupts the control circuit and stops the distributor-transmitter until the condition of the tape is corrected. Transmission will then resume automatically.

- c. TAPE-OUT. (See figure 3-1.) — At the end of a tape or if the input tape is torn, a tape-out pin similar to the sensing pins and located just in advance of the sensing pins is permitted to extend beyond its normally depressed position. The tape-out pin then

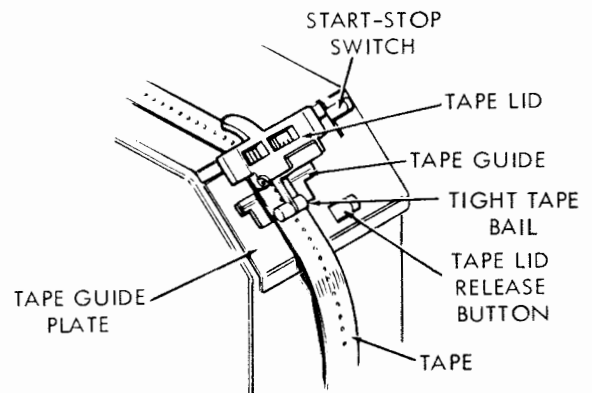

Figure 3-1. Path of Tape in Distributor-Transmitter

opens the normally closed tape-out contacts to interrupt the control circuit and stop the distributor-transmitter. Transmission will resume automatically when the condition of the tape is corrected. Opening the tape lid while the distributor-transmitter is in operation (depressing the red button on the tape lid plate) has the same effect as a tape-out condition.

3-5. MANUAL CONTROLS.

a. GENERAL. — There are three manual controls, the main power switch, the start-stop switch, and the tape lid button.

b. MAIN POWER SWITCH. — The main power switch is a toggle switch located at the rear of the base. An aperture in the rear of the cover provides access to the switch. The switch is OFF in down position, and ON in up position.

c. START-STOP SWITCH. — The start-stop switch is located at the rear of the distributor-transmitter mechanism on the right-side of the equipment. The green toggle switch is off in center (STOP) position, RUN in extreme right position, and FREE for free-wheeling manual tape feed in extreme left position. The electrical control circuit is off in either the STOP or FREE positions.

NOTE

This switch is also actuated automatically when in RUN position by the tight tape bail (paragraph 3-4b).

d. TAPE LID RELEASE BUTTON. — The tape lid release button is a red anodized aluminum button on the tape lid plate. Depressing the button manually unlatches the spring loaded tape lid to swing open for loading or removing tape. The automatic tape-out feature interrupts the control circuit when the tape lid button is operated. The tape lid is re-latched manually.

3-6. OVERLOAD CUTOUT.

Change # T-1
~~Distributor-Transmitter~~ *SYNCHRONOUS* motors are equipped with thermal circuit breakers to protect against excessively high temperature which might develop in case of a prolonged overload that would be sufficient to stall the motors. Once operated, these cutout devices must be reset manually by pressing a reset button (figure 1-3) on the motor plate beneath the motor

before the equipment can be restarted. Allow the motor to cool at least five minutes before manually depressing the red button.

CAUTION

If the motor stops and does not restart in response to regularly operated controls, check for blown fuses in external power supplies (there are no internal fuses in the equipment). If the fuse has not blown, check the motor for excessive temperature. Where excessive temperature is indicated, rotate the motor by hand to determine whether any abnormal mechanical condition is present. If the load appears normal, leave the cover off to permit the temperature to drop before resetting the cutout switch. If the motor continues to cut out, or if any abnormal load conditions cannot be readily corrected, notify authorized maintenance personnel.

3-7. SUMMARY OF OPERATIONS.

a. Turn the main power switch at the rear of the cover to up (ON) position.

b. Depress the red tape lid button to open the tape lid, and load coded, perforated message tape. Position the tape, using the index mark on the tape lid, so the first character to be transmitted is over the sensing pins. Close the tape lid.

c. Move the start-stop switch to its extreme right (RUN) position.

d. To shut down the equipment, turn the start-stop switch to its center position (STOP). Shut off power to the equipment at the main power switch. Depress the tape lid button to remove the message tape.

3-8. ROUTINE CHECKS.

Unless there is local monitoring (receiving) equipment in the distributor-transmitter signal circuit, there is no practical check on the transmission. The equipment is designed for long periods of trouble free operation without readjustment. The cover and the tape lid should be kept clean, free of dirt, grease or other foreign matter. Check the tape feed mechanism to be sure it is free of accumulations of dust and lint, which may be cleaned as necessary with a soft brush.

(SEE T-1) FOR REFERENCE TO THE FOLLOWING PARAGRAPHS
3-9 SPEED SETTING
PAGE # 4 (IN T-1)

SECTION 4

THEORY OF OPERATION

4-1. GENERAL.

a. This section covers the operating principles and circuit descriptions of Distributor-Transmitters TT-187/UG and TT-187A/UG. The equipment is for transmission of messages only. Coded representations of alphabetical and numerical symbols and teletypewriter functions are read from pre-punched tape and converted into electrical signal intelligence for transmission along radio or wire telegraph channels connecting two or more ships or stations equipped with compatible units. Operation of the sets is fully automatic when tape is properly installed in the reading head, the main power switch is in ON position, and the start-stop switch is in RUN position.

Change # 7-1 PAGE 4 TT-187/UG TT-187A/UG
 b. ~~The signals transmitted by these distributor-transmitters are of the neutral type (open and close)~~ direct current, 7.42 unit start-stop pattern, with a nominal speed of 368 o.p.m. Gearing changes can adapt the equipment to 460 or 600 o.p.m., with equivalent word speeds of 60, 75 or 100 w.p.m. The equipment will operate on either 0.060 or 0.020 ampere signal current, externally supplied.

c. Distributor-Transmitters are powered by self-contained a.c. synchronous motors. The motors require a power supply of 115 volts (plus or minus 10 percent) 60 cycle, single phase alternating current. To avoid loss in receiving margin with this type of motor, the frequency regulation must be within plus or minus one-half cycle. Governed motors and motors operating on direct current are available for Distributor-Transmitter TT-187/UG only but are not furnished with the set.

d. The general electrical and mechanical relationships of the components of the distributor-transmitter are shown in figure 4-1, the System Block Diagram.

4-2. SIGNALING CODE.

a. The distributor-transmitter operates on the principle of electro-mechanical conversion of message characters, equivalent to alphabetical or numerical characters or standard teletypewriter functions (see figure 4-2). Teletypewriter equipment utilizes the Baudot code, a five-unit start-stop signaling code in which each character or function is represented by a combination of current and no-current time intervals. In a neutral teletype circuit, intervals during which current flows in the signal circuit are referred to as "marking" elements, and intervals during which no current flows as "spacing" elements. Every combination includes five elements that carry the intelligence, each of which may be either marking or spacing.

b. The intelligence elements are preceded by a start element (always spacing) and are followed by a stop element (always marking) which is 1.42 times as long as each of the other elements. Thus, each combination consists of 7.42 units of time (referred to as a 7.42 unit transmission pattern). The start and stop elements provide for mechanical synchronization between the transmitting and receiving equipment. A graphic illustration of the marking and spacing elements in each sequence may be found in figure 4-3, Code Representation of the Letters "R" and "Y." All five elements are marking in the letters code. The blank code is comprised of five spacing elements.

c. Some telegraph systems employ a 7.00 unit transmission pattern in which the stop element is equal to each of the other elements. Interoperation between 7.42 and 7.00 apparatus is satisfactory providing the operating speeds selected yield identical pulse lengths. (See table 4-1.) The signaling frequency is expressed in dot cycles per second. One cycle consists of one current pulse followed by a no-current pulse. The equipment speed in baud is equal to twice the frequency. Speed in words per minute is roughly equivalent to one-sixth the operations per minute.

4-3. DISTRIBUTOR-TRANSMITTER.

a. GENERAL. (See figure 4-1.) The purpose of the distributor-transmitter is to decode the intelligence stored in perforated tape (either chadless or fully perforated) and to transmit that intelligence through a radio or wire telegraph channel in the form of sequential marking or spacing signal pulses in a 7.42 unit transmission pattern at speeds of 368, 460 or 600 o.p.m. (60, 75 or 100 w.p.m.). Distributor-transmitters used on Distributor-Transmitters TT-187/UG and TT-187A/UG differ only in provisions for their electrical connection to the base. These differences are indicated in the schematic wiring diagram, figure 6-37.

b. ELECTRICAL FEATURES. — The distributor-transmitter mechanism is wired for operation on 115 V a.c., with externally supplied direct current signal power through the signal generator. With modifications to add resistance to the clutch magnet circuit, the sets will operate on 120 V d.c. or 50 V d.c. Both control circuit and signal circuit distribution is through the base, which is supplied by cable connection to external sources. The main power switch on the base controls the a.c. circuit.

(1) The a.c. control circuit is series wired through the start-stop switch and the tape-out switch to operate the two 74 ohm clutch control magnets.

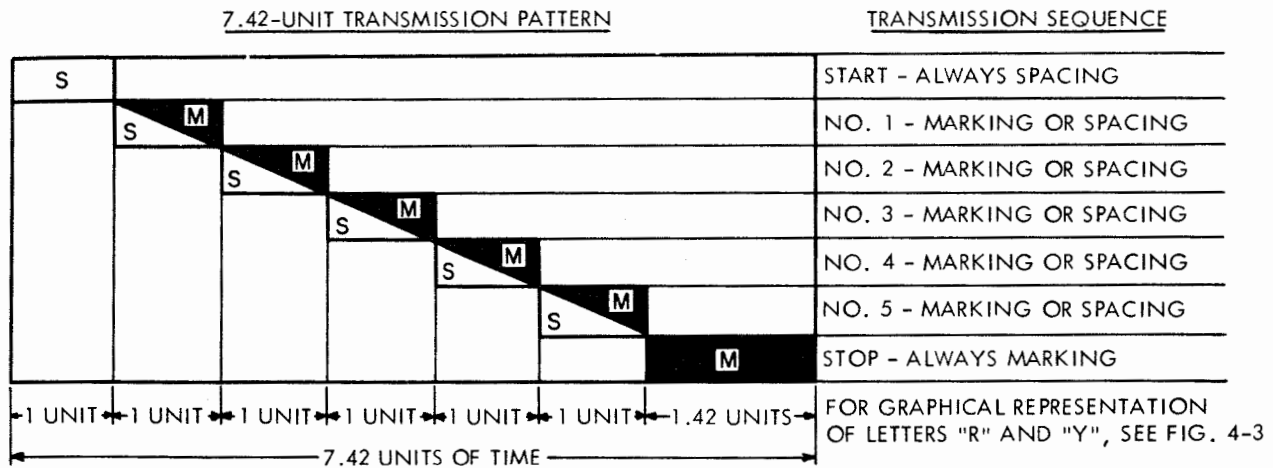

FIGURES	-	?	:	\$!	&	8	'	()	.	,	9	∅	1	4	Δ	5	7	;	2	/	6	"	∥	<		■	▼	▲		
LETTERS	A	B	C	D	E	F	G	H	I	J	K	L	M	N	O	P	Q	R	S	T	U	V	W	X	Y	Z	BLANK	C.R.	L.F.	SPACE	LTR.	FIG.
1	●	●	●	●	●				●	●					●	●	●	●	●	●	●	●	●	●	●						●	●
2	●	●				●	●	●	●	●	●	●	●	●	●	●	●	●	●	●	●	●	●	●	●			●			●	●
FEED HOLES	○	○	○	○	○	○	○	○	○	○	○	○	○	○	○	○	○	○	○	○	○	○	○	○	○	○	○	○	○	○	○	○
3			●	●	●	●	●	●	●	●	●	●	●	●	●	●	●	●	●	●	●	●	●	●	●						●	●
4	●	●	●	●	●	●	●	●	●	●	●	●	●	●	●	●	●	●	●	●	●	●	●	●	●			●			●	●
5	●					●	●				●	●	●	●	●	●	●	●	●	●	●	●	●	●	●						●	●

Figure 4-2. Signal Code

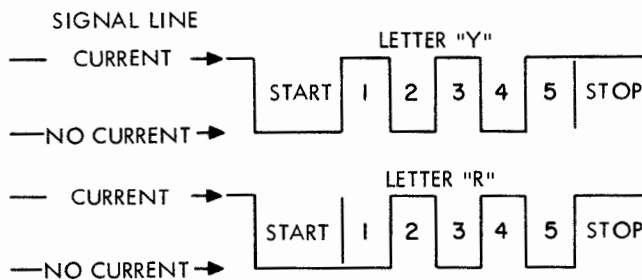

Figure 4-3. Code Representations of the Letters "R" and "Y"

With tape correctly loaded in the reading head, operation of the start-stop switch will energize the clutch magnets and hold them in this condition for continuous transmission until the circuit is interrupted either by opening the start-stop contacts or by action of the tape-out pin on the tape-out switch. The start-stop contacts could be opened by mechanical operation of the tight-tape feature or by moving the start-stop switch to STOP position.

(2) The signal circuit is an external closed circuit which, except for spacing intervals during signal transmission, is always closed, regardless of the operating condition of the distributor-transmitter. TT-187A/UG is equipped with a line shunt

switch on the base to maintain the closed condition of the signal line automatically when the distributor-transmitter mechanism is removed from the base.

(3) TT-187/UG. — Both power and signal connections to the distributor-transmitter are supplied through a single cable wired to the upper and lower terminal boards of the base. There is no provision for signal line continuity if the cable is disconnected from the terminal board.

(4) TT-187A/UG. — All electrical requirements for power and signal circuits are supplied through a 36-point connector J850 mounted on a bracket at the bottom of the distributor-transmitter. The connector mates with receptacle P301 on the base. P301 is wired to base terminal boards. The connector mounting bracket also mounts a line shunt switch operating screw which automatically opens the line shunt switch on the base when the distributor-transmitter is mounted in operating position.

c. CAM-CLUTCH MAIN SHAFT. (See figure 4-4.) — The cam shaft is an integral part of the main shaft, attached by a hub at the rear of the shaft to the disk of the clutch. The drum rotates freely about the shaft with the helical driven gear, to which it is attached. The cam-clutch has five sensing pin transfer lever cams, a start cam, a stop cam and a locking bail cam. The cams are positioned to trip their associated mechanisms in the order required for sequential electrical transmission of the marking and spacing

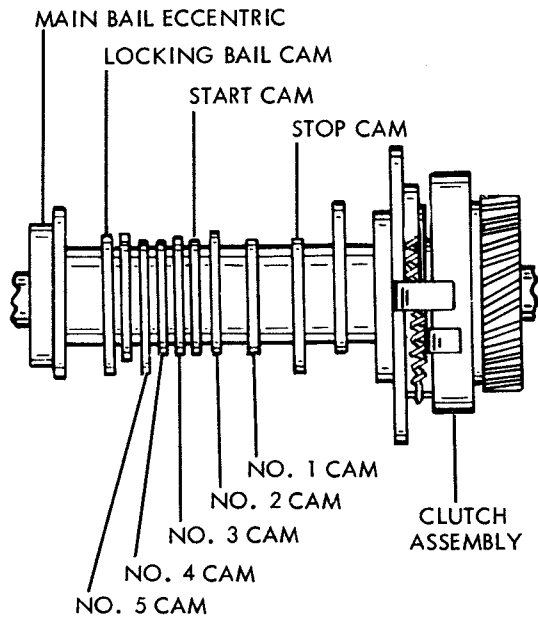

Figure 4-4. Cam-Clutch Main Shaft

elements of the simultaneous character code perforations of the tape input. The shaft also has an eccentric cam to operate a main bail drive arm during the function cycle.

(1) When the start-stop lever is moved to the right, the camming surface of the lever (figure 4-5) allows the start-stop bail to move upward. As the bail pivots on its mounting, the left extension of the

bail moves away from the swinger of the start-stop tight tape contact assembly and closes its contact to complete the clutch magnet circuit. As the armature is pulled up (figure 4-6), it rotates the main bail latch lever, which frees the spring loaded main bail to rotate counterclockwise. The movement is transmitted through an eccentric post (figure 4-7) to the clutch trip bail. The bail moves the clutch trip lever out of engagement with the clutch shoe, releasing the clutch to start the main shaft rotating.

(a) When power is on (motor operating), the clutch drum rotates continuously in a clockwise direction (viewed from the front). When the clutch trip lever releases the clutch shoe, the primary and secondary shoes engage a serrated surface on the inside of the clutch drum. The clutch shoes are mounted on a plate which is a part of the cam assembly, and the cam rotates when the shoes are engaged.

(b) Figure 4-8 shows a clutch disengaged. Stop lug A on the cam-clutch disk is brought close to the lower end of clutch shoe lever B by the inertia of the previous revolution of the clutch. It is held in place by the latch lever. The upper end of lever B pivots about its ear C and allows its other ear D to move toward the right. The upper spring then pulls the two shoes together and away from the drum. The drum rotates freely in an idling condition, while the distributor-transmitter is inoperative.

(c) Figure 4-9 shows the same clutch engaged. This is accomplished by releasing the lower end of lever B. The upper end of lever B pivots about its ear C (which bears against the upper end of the

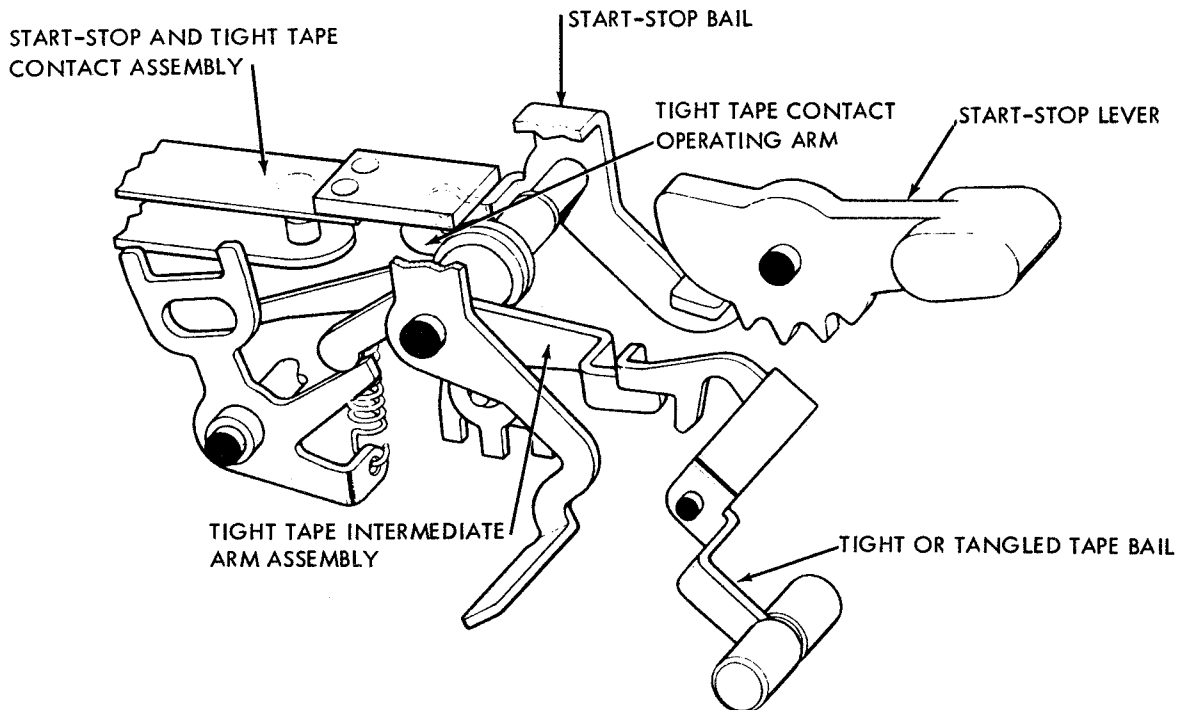

Figure 4-5. Start-Stop Lever and Tight Tape Switch Mechanism

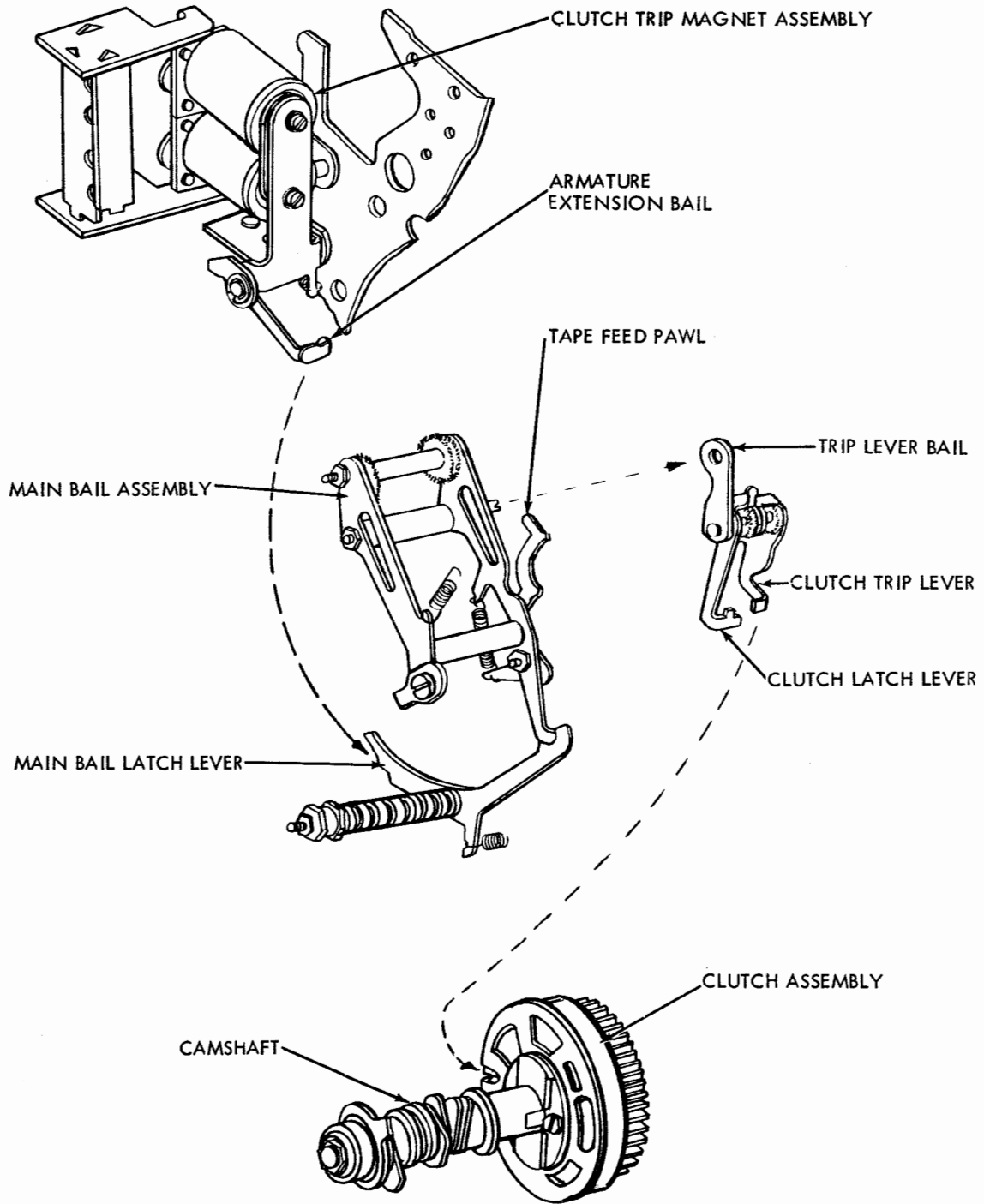

Figure 4-6. Control Mechanism

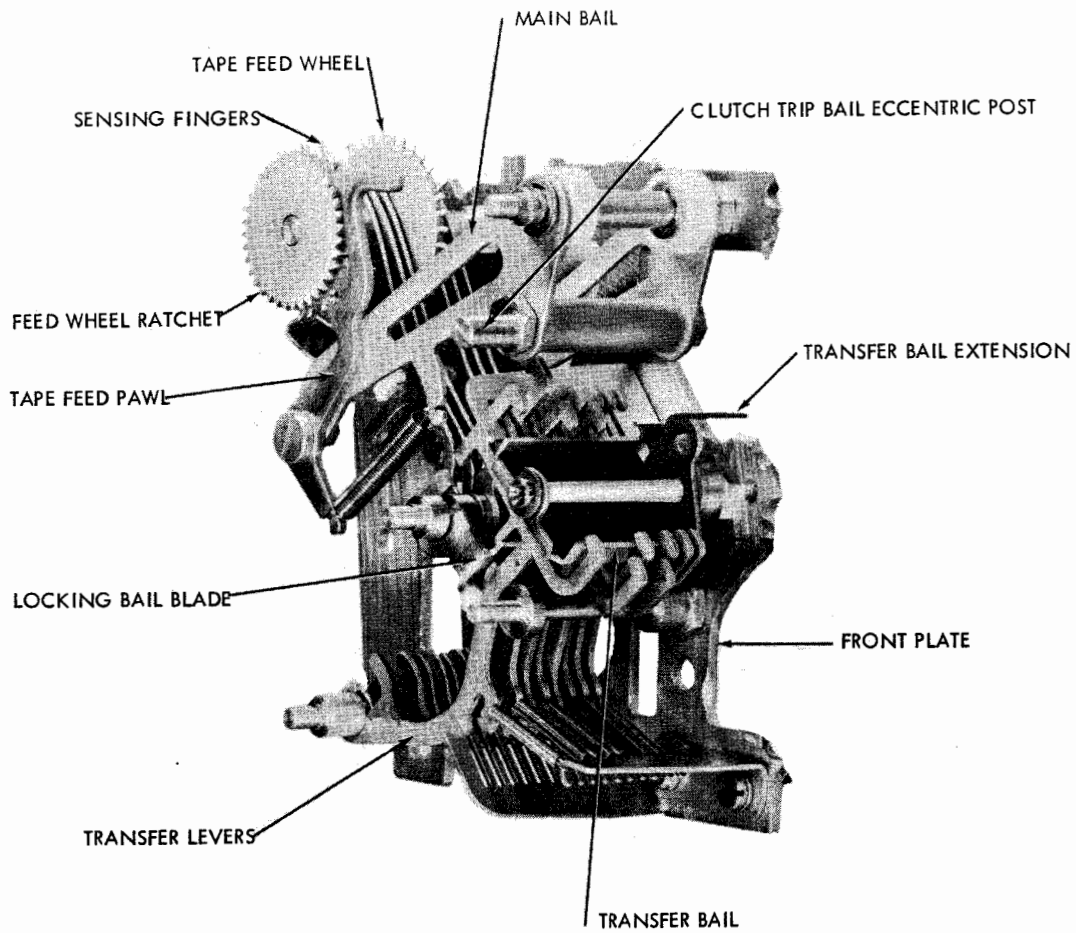

Figure 4-7. Front Plate Mechanism (Rear View)

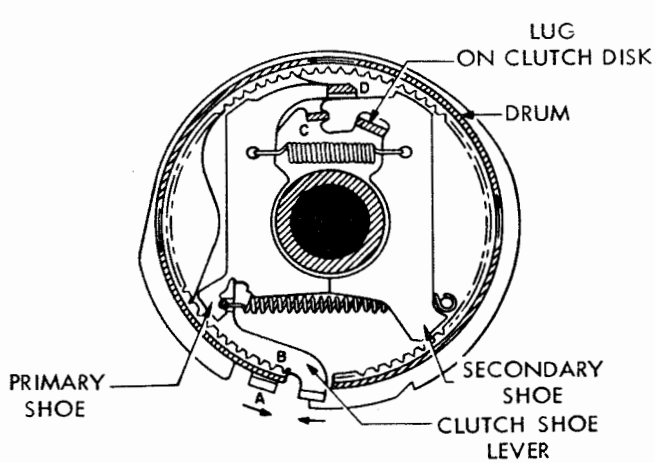

Figure 4-8. Clutch, Disengaged

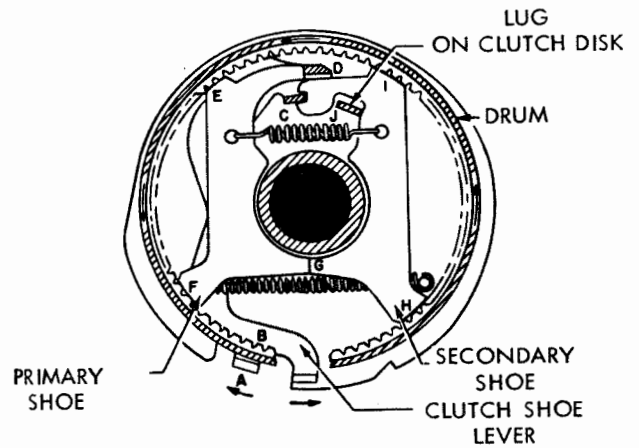

Figure 4-9. Clutch Engaged

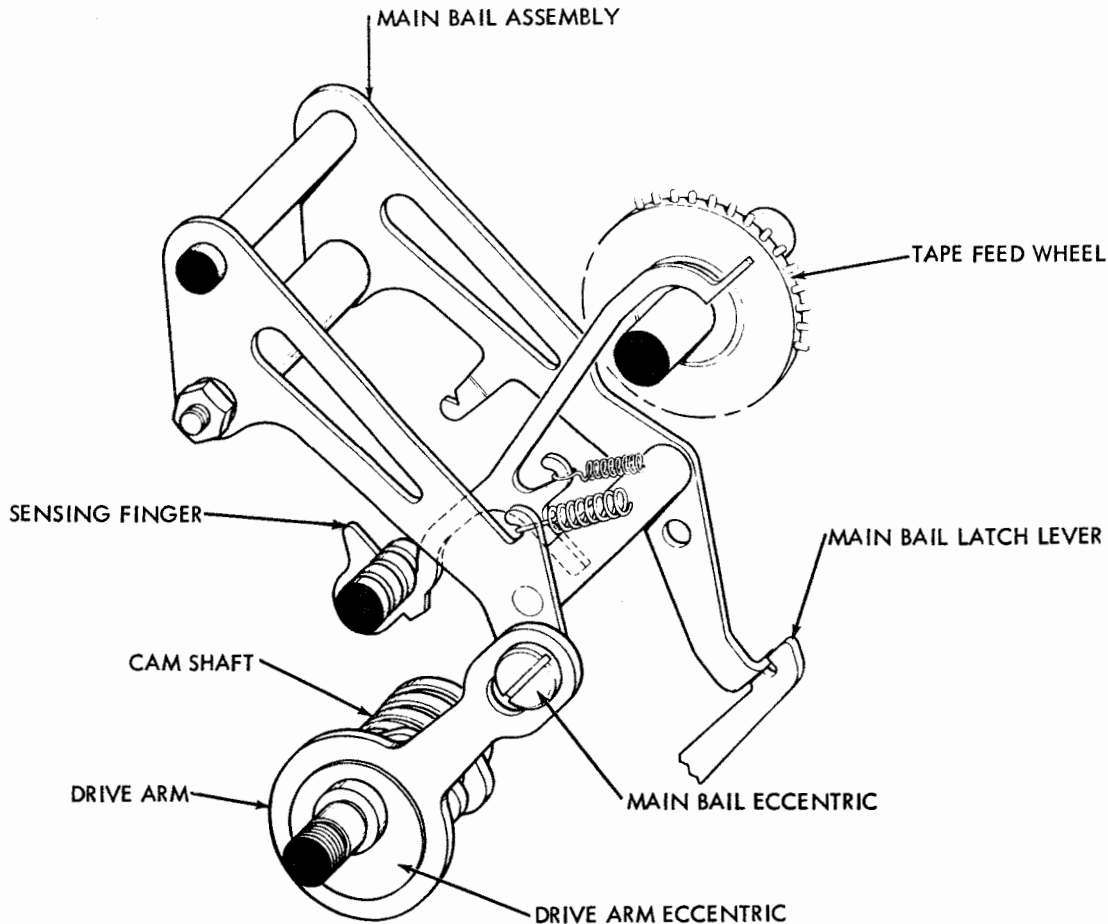

Figure 4-10. Main Bail and Drive Arm Mechanism

secondary shoe) and moves its ear D, and the upper end of the primary shoe, toward the left until the shoe makes contact with the drum at point E. As the drum turns counterclockwise, it drives the primary shoe downward, so that it again makes contact with the drum, this time at point F. There, the combined forces acting on the primary shoe cause it to push against the secondary shoe at point G. The lower end of the secondary shoe then bears against the drum at point H. The revolving drum acts to drive this shoe upward so that it again makes contact with the drum at point I. Since the forces involved are multiplied at each of the preceding steps, the final force developed at point I is very great. This force is applied to the lug J on the clutch cam disk to cause it to turn in step with the drum. The cam disk is a part of the distributor-transmitter cam assembly, which rotates upon engagement of the clutch.

(2) As the shaft rotates, the drive arm eccentric (figure 4-10) revolves to pull the drive arm downward, causing the main bail to pivot back to its home position. So long as the magnet circuit is not interrupted, the armature continues to hold the main bail latch lever away from the main bail. As the shaft continues to rotate, the drive arm is moved

upward by its eccentric, and the spring loaded bail again rotates counterclockwise. The clutch trip lever is held away from the clutch shoe and the cam-clutch cycling continues.

(3) When the start-stop lever is pushed to its center "STOP" position, the start-stop bail (figure 4-7) is rotated clockwise, and its left extension raises the swinger of the start-stop tight tape contact, interrupting the magnet circuit. The magnet armature falls away from the pole pieces, under spring tension, and the main bail lever is latched when the drive arm lowers the main bail.

(4) As the main bail is latched, the clutch trip lever blocks the clutch shoe lever. When the clutch is blocked, the inertial of the mechanism causes the clutch to rotate far enough to permit its latch to fall into the notch on the clutch cam disk. The rotation of the main shaft and cams is stopped. The clutch drum continues to rotate with the driven gear.

d. SIGNAL INTELLIGENCE INPUT. - Operation of the distributor-transmitter when the electro mechanical requirements for cam-clutch and main shaft operation have been established are in response to

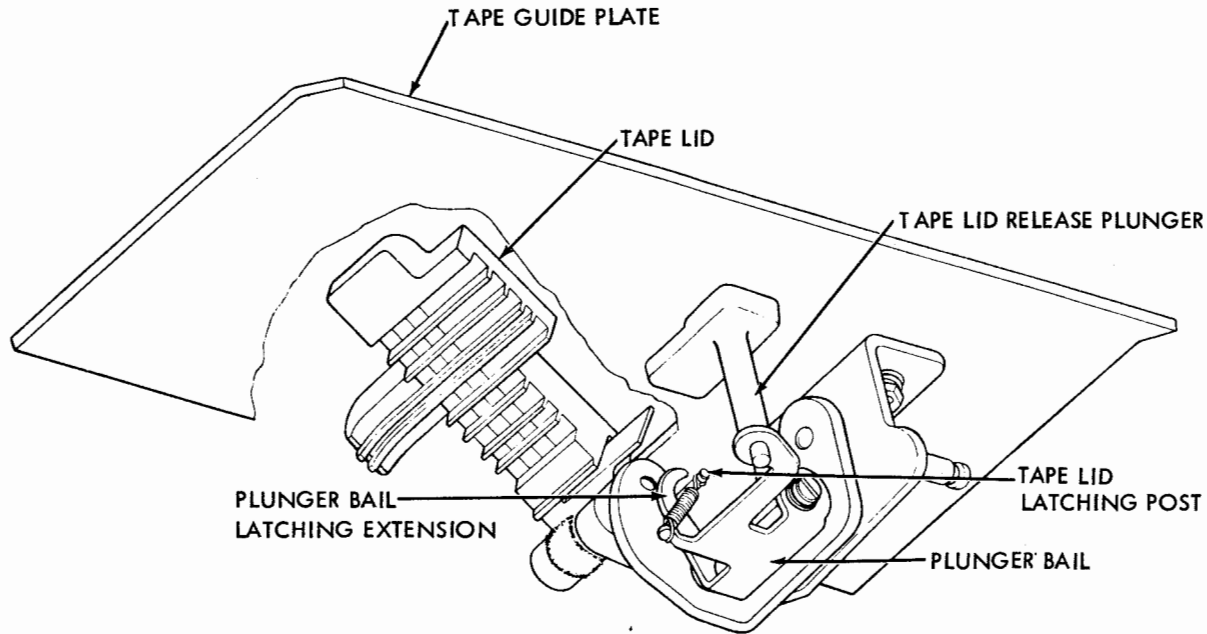

Figure 4-11. Tape Lid Mechanism (Bottom View)

the signal intelligence data stored in five-unit code perforations fed in simultaneous arrangement, character by character order as they appear in the tape, to the sensing mechanism. The signal intelligence input must conform to the signal requirements of the equipment (paragraph 4-2).

(1) TAPE LID OPERATION. (See figure 4-11.)

— When the red lid button is depressed, the tape lid release plunger under the tape guide plate depresses the plunger bail extension, causing the bail to pivot counterclockwise. The plunger bail latching extension swings downward, away from the tape lid latching post. Under spring tension, the lower portion of the tape lid rotates counterclockwise, raising the tape lid.

(a) With the tape lid open, the perforated message input tape can be placed in the tape guide so that its feed holes engage the teeth of the feed wheel. Typed tape is inserted with the typed, chad side upward. The position of the feed wheel, off center to the rear of the tape, insures correct positioning of the tape. If non-typed chadless tape is used, the position of the tape can be determined by noting that the open side of the hinged chads is to the top. If fully perforated non-typed tape is to be fed into the distributor-transmitter, caution must be exercised to feed the tape from the beginning, rather than the end, which would be inverted.

(b) The perforations of the first character to be transmitted must be located over the apertures for the sensing pins. The position of the tape can, however, be adjusted after the tape guide lid is closed, as described in paragraph 4-6c(2).

(c) The tape lid is closed manually by pressing it down over the positioned tape. When the tape

lid is closed, the latching post rotates counterclockwise, over the end of the plunger bail latching extension. Under spring tension, the latching extension is pulled under the post to latch the tape lid.

(2) FREE-WHEELING FEED WHEEL. (See figure 4-12.) — When the start-stop lever (figure 4-5) is pushed to the extreme left position, the start-stop bail is rotated clockwise. The bail extension pushes the feed pawl and the ratched detent roller out of engagement with the feed ratchet, allowing the feed wheel to rotate freely (figure 4-12). The bail extension also contacts the intermediate bail, which rotates clockwise, permitting the torsion spring loaded depressor bail to rotate, moving the tape-out pin flush with or below the tape guide plate. This permits free passage of the tape under the tape lid. Since the start-stop tight tape contacts are opened in establishing conditions for free-wheeling tape feed, the clutch magnets are de-energized, and the distributor-transmitter is in an idling condition. Positioning of the tape must be done manually. Release of the start-stop lever to its "STOP" position returns the tape feed pawl and detent roller into contact with the ratchet and releases the tape-out sensing pin, conditioning the equipment for operation when the start-stop lever is again moved to the right.

(3) TAPE-OUT SWITCH MECHANISM. (See figure 4-12.) — A tape-out sensing pin is located on the tape guide plate to the right and slightly forward of the five tape sensing fingers. An extension near the top of the sensing pin raises the swinger of the normally open tape-out contact when the spring loaded pin protrudes above the guide plate. When the pin is depressed, the swinger is released to close the contacts and close the clutch magnet circuit at this point.

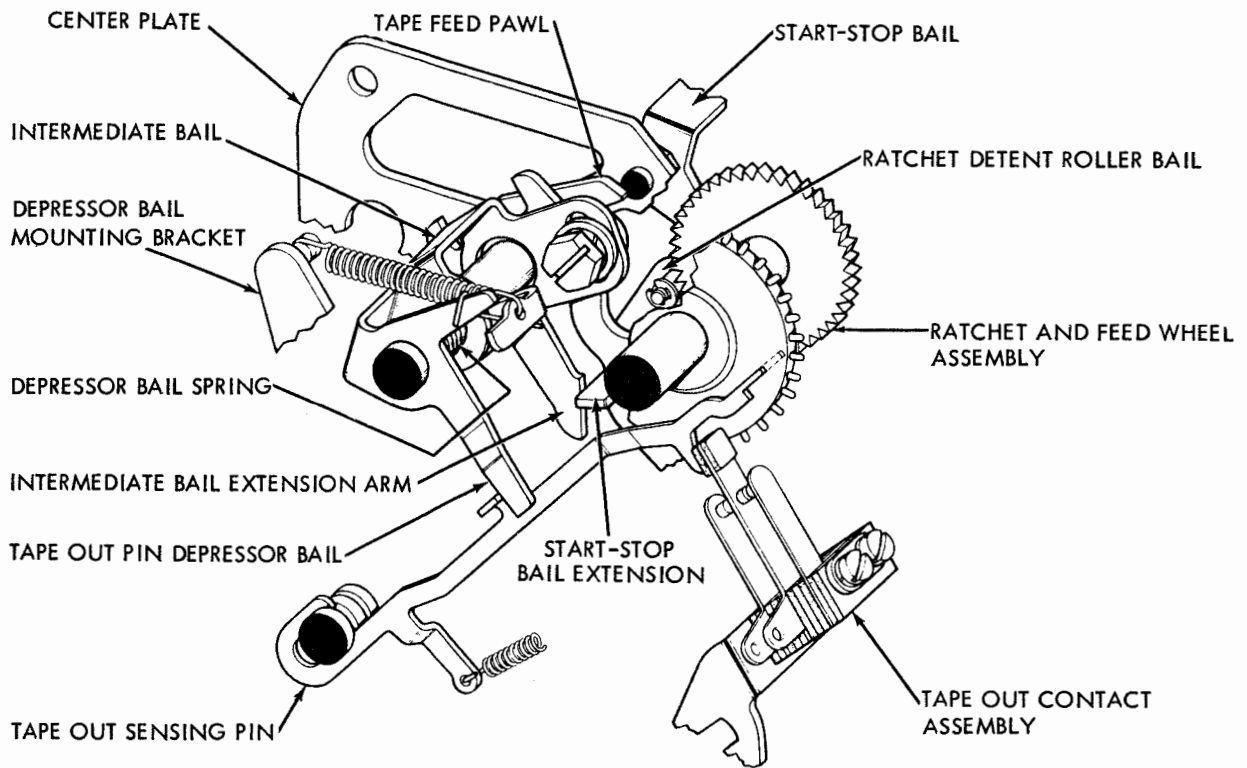

Figure 4-12. Free Wheeling and Tape-Out Mechanism

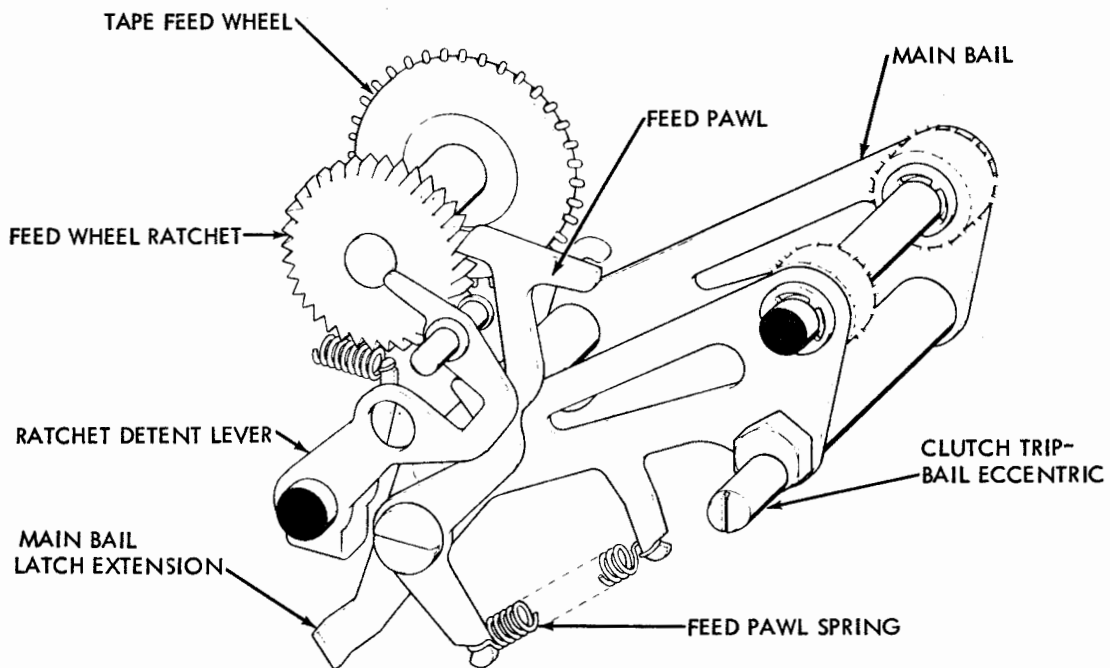

Figure 4-13. Tape Feed Mechanism

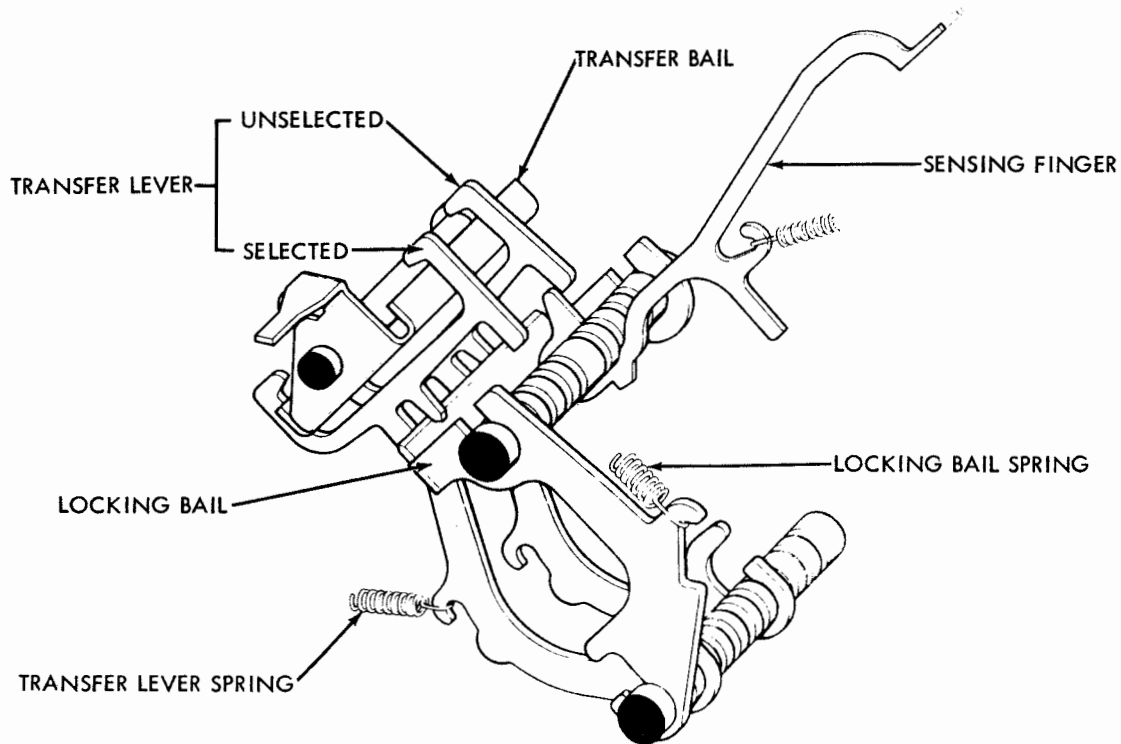

Figure 4-14. Sensing, Locking and Transfer Lever Mechanism

When tape is in the unit and the tape guide lid is closed, the tape holds the sensing pin in depressed position, closing the contacts and permitting transmission when related elements of the series wired clutch magnet circuit are closed. During transmission, the code sensing fingers cannot differentiate between a no-tape condition and a LETTERS code (five marking units) and would tend to continue transmission of a false letters signal. The tape-out sensing pin, however, moves upward under tension of its spring and opens the magnet circuit, interrupting transmission. De-energizing the magnets releases the armature, permitting the armature extension to pivot out of its blocking position and allowing the main bail latch to be moved by its spring. The clutch latch lever contacts the clutch shoe lever and blocks rotation of the cam-clutch mechanism and shaft (figure 4-6).

(4) TIGHT TAPE SWITCH MECHANISM. (See figure 4-5.) — Tight or tangled tape raises the tight tape lever on the tape guide lid, rotating the tight tape bail counterclockwise. The bail arm pivots the intermediate arm clockwise, raising the contact arm upward, to lift the swinger of the start-stop tight tape contact upward to open the clutch trip circuit to stop transmission. Transmission will be resumed automatically when the condition is remedied, since the start-stop switch remains in operating condition through the interruption in transmission.

(5) TAPE FEED MECHANISM. (See figure 4-13.) — As the armature-released main bail swings upward (figure 4-6), the tape feed pawl is raised one

tooth on the feed wheel ratchet (figure 4-13). When the drive arm brings the main bail downward (paragraph 4-6c(1)), the tape feed pawl advances the tape feed ratchet one tooth against the action of the ratchet detent roller. The tape feed wheel advances the tape one character. The ratchet detent roller bears between two teeth on the ratchet and serves to hold the feed wheel and tape in position during the sensing portion of the operating cycle. As the drive arm moves the bail upward, the tape feed cycle is resumed.

e. SENSING MECHANISM. (See figure 4-7.) — Five sensing pins in the upper ends of five sensing fingers alternately protrude from and retract beneath the tape guide plate, under the tape guide lid. The lower end of the fingers (figure 4-14) slide freely on a positioning stud, with their lower extensions under their associated transfer levers. A spring hook and extension arm about midway on each sensing finger depresses the fingers beneath the main bail when the main bail is in its lower position and releases them, under tension of their springs, to protrude through the guide plate when the main bail is raised. If one or more of the sensing pins encounters a perforation in the tape, the fingers will extend through the perforation. The sensing fingers that extend through the tape move their associated transfer levers upward, so that they are brought above the line of action of the locking bail. If any of the sensing fingers do not sense a perforation in the tape, the associated transfer levers remain stationary, and their extensions remain below the line of action of the locking

blade on the locking bail. When the main bail drive arm shaft impels the bail downward, the bail pulls the sensing fingers downward, to permit the tape to advance without interference.

f. LOCKING BAIL AND TRANSFER MECHANISMS. (See figure 4-14.) — All transfer levers except the start and stop transfer levers are arranged to move in two directions. The forked end can be moved from the selected (marking) position to the unselected (spacing) position by the associated sensing pins, depending on the character code intelligence at the head of the tape guide. The transfer levers are also moved downward and to the right in a sequence actuated by the cam-clutch mechanism to rotate the transfer bail into marking or spacing position in a sequential pattern to conform to the 7.42 unit transmission pattern. It is at this point that the simultaneously sensed elements of the tape perforated character code is converted to a sequence of start spacing, marking or spacing and stop marking characteristics required for signal line transmission.

(1) Selection of the transfer levers in spacing or marking position is instantaneous in response to the movement of the sensing fingers when the main bail is driven upward either by spring action, to start transmission, or by the drive arm, in continuous transmission. As the cam-clutch rotates, the locking bail cam positions the locking bail upward between the lower extensions of the selected transfer levers, locking them in position.

(2) Further rotation of the main shaft moves the lobe of the start cam into position and shifts its transfer lever downward. Since the start transfer lever has no sensing finger, the lever is always in the spacing position. The start transfer lever upper finger always hooks the upper side of the transfer bail and causes it to move clockwise (spacing).

(3) As the shaft rotates further, the cam for the first pulse moves its transfer lever downward and toward the right. Depending on the position of the transfer lever finger (upper fork engaging bail, spacing; lower fork engaging bail, marking), the transfer bail is rotated if the pulse to be transmitted is not the same as the preceding pulse. If the preceding pulse is the same, no action occurs, because the bail has been previously rotated. If the preceding pulse was different, the extension on the transfer bail is moved to the right to spacing position or to the left to marking position (figure 4-15).

(4) The second, third, fourth, and fifth pulses are generated in the same manner as described for the first pulse.

(5) The stop cam pulse follows the fifth cam pulse as the main shaft completes a cycle. Again, the action is the same as that for the first pulse, except that, since the stop pulse transfer lever has no sensing finger, and its transfer lever is blocked by the locking bar, its lower finger always hooks the transfer bail, resulting in positioning the transfer bail extension to the left (marking).

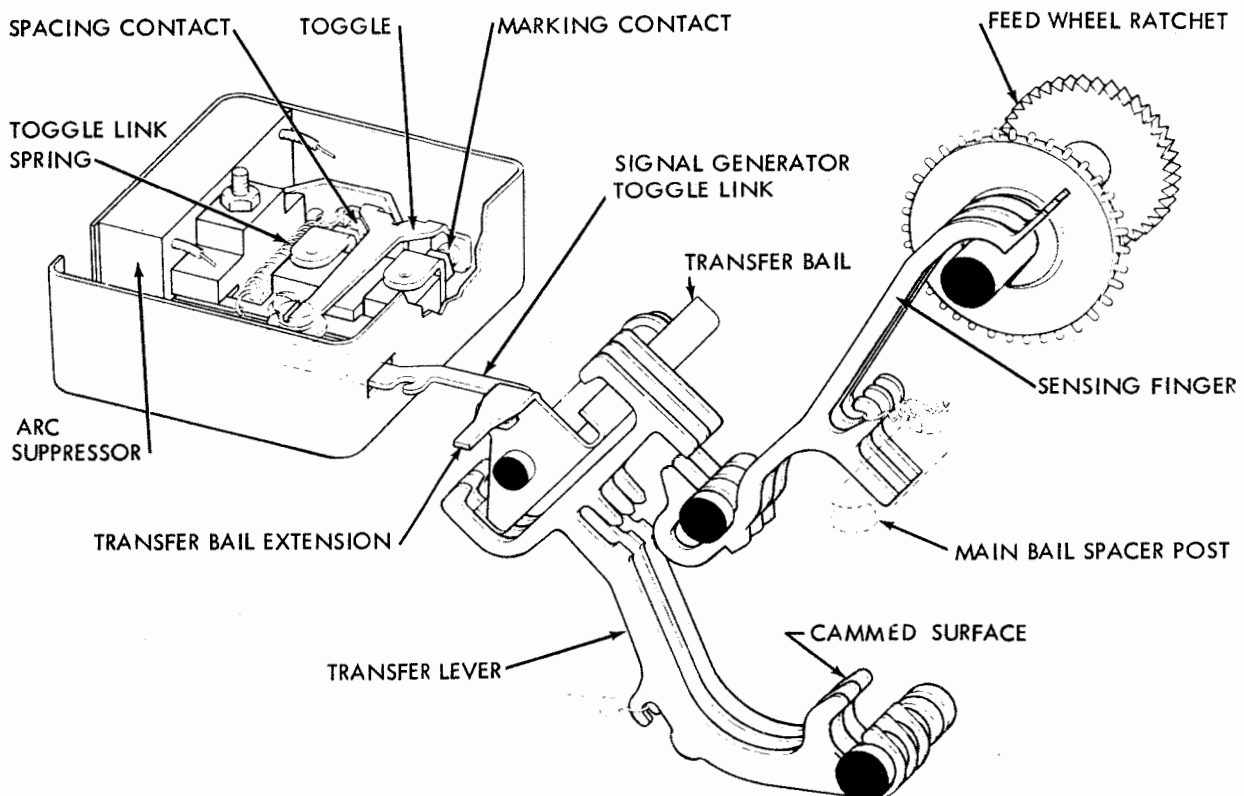

Figure 4-15. Signal Generator Mechanism

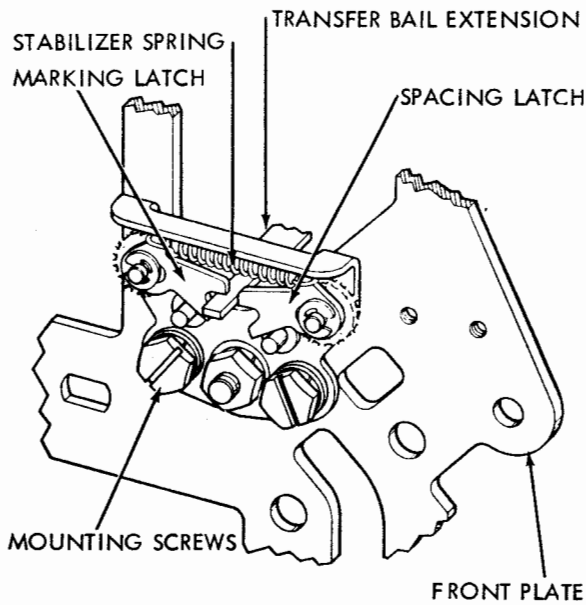

Figure 4-16. Transfer Bail Stabilizer

g. SIGNAL GENERATOR MECHANISM. (See figure 4-15.) — The transfer bail extension, moving to the right (spacing) or left (marking) as the bail rotates under the impulse of the selected or unselected transfer levers, clears the left (spacing) or right (marking) latch in the stabilizer mechanism (figure 4-16), permitting the latch to drop and hold the bail, through the extension, until an opposite pulse is transmitted. The transfer bail is linked to the signal generator toggle. Rotation of the bail moves the toggle to the right to open the marking contact and close the spacing contact in the signal generator, or to the left to close the marking contact and open the spacing contact. The opening of the marking contact interrupts the input signal line current (d.c.), and the successive spacing and marking pulses impress upon the signal line the code for the character represented in the perforated tape at the head of the tape guide.

4-4. DISTRIBUTOR-TRANSMITTER BASE. — Two mechanisms on which components of Distributor-Transmitter TT-187/UG and TT-187A/UG are mounted are fundamentally similar except in size. TT-187A/UG sets use the miniaturized base, which is further distinguished, functionally, by a 36-point connector and a line shunt switch.

a. Both bases provide rigid mounting support for the distributor-transmitter and motor. The cover fits over and clips to the top and the front of the base. An intermediate gear mechanism transfers mechanical motion from the motor shaft to the distributor-transmitter shaft in a ratio determined by the desired operating speed.

b. Both bases provide terminal connections for external power, signal and ground circuits. There is a main power switch (S201) at the rear of the base.

Interconnections between components are made on two terminal boards, an upper (TB201) and lower (TB202) terminal board, on the rear of the base. Refer to figure 6-36 for electrical circuitry.

(1) TT-187/UG. — The distributor-transmitter cable connection to the large base is made directly on the upper and lower terminal boards. There is no line shunting provision on this base.

(2) TT-187A/UG. — The miniaturized base provides a 36-point receptacle (P301) for interconnection with a mating connector (J850) on the distributor-transmitter. There is also a line shunting switch (S311) which automatically closes the signal line before the connection at P301 is broken.

Change T-1 PAGE 5

4-5. A.C. MOTORS. (SYNCHRONOUS) SE 4-7

a. Mechanical driving power for Distributor-Transmitter TT-187/UG and TT-187A/UG is supplied by synchronous a.c. motors. The difference between the two motors is in size and weight. Both operate on single phase 115 volt (plus or minus 10 percent) alternating current at a frequency of 60 cycles per second (plus or minus 0.5 cycle). Wiring for the two motors (figure 4-17) is identical except for circuit component values (see figure 6-37).

b. Both motors are 3600 rpm, two pole, wound stator, ball bearing motors with a squirrel cage

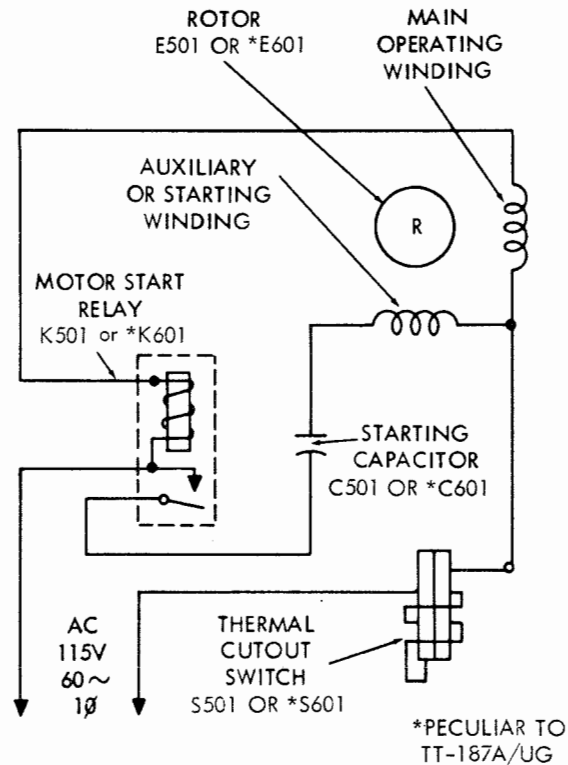

Figure 4-17. A.C. Synchronous Motor for TT-187/UG or TT-187A/UG, Schematic Wiring Diagram

type rotor. The stator has two windings, a main operating winding and an auxiliary starting winding. The auxiliary winding is in series with an electrolytic capacitor (C501 or C601) and with a current operated starting relay (K501 or K601).

(1) The initial starting current causes the relay to pull up, and its contacts to close the auxiliary winding circuit. As the rotor gains speed, the current flowing through the motor, and through the relay coil, decreases. When a predetermined current value is reached, the relay armature is released, the relay contacts are opened, and the auxiliary winding circuit is disconnected from the line. The rotor continues to accelerate until it reaches synchronous speed (3600 rpm). The motor is wired in such a way that the rotor revolves clockwise when viewed from the shaft (pinion) end.

(2) The starting relay and capacitor together with a thermal cut-out switch are mounted beneath the motor mounting cradle. The thermal cut-out switch is in series with both the main and the auxiliary motor windings, and if excessive current is drawn by the motor, due, for example, to a blocked rotor, the switch will open the circuit. This is to prevent overheating and possible damage to the motor if it is stalled. The switch may be manually reset if tripped by depressing the red button which projects upward through the motor mounting plate. Allow the motor to cool at least 5 minutes before manually depressing the red button.

c. TT-187/UG. — A combination hand wheel and fan is mounted on the rear of the motor shaft.

d. TT-187A/UG. — A sheet metal shield wrapped around the outside of the miniaturized motor deflects cooling air currents around the internal components of the motor and exhausts warm air from the vents on the left-side of the cover.

e. End bells of both motors have rubber vibration mounts on which the motors are suspended in their mounting cradles. The rubber mounts are held at each end of the cradle by a pair of mounting straps. The motor shaft has a tapped hole for attaching the selected intermediate gear driving pinion. The pinion is mounted in a rubber retainer on two mounting posts inserted from opposite sides of the shaft. It is mounted with its hub away from the motor.

f. The motor mounting cradle is attached to the distributor-transmitter base by four screws and lock washers.

4-6. COVER.

The principle purpose of the distributor-transmitter cover is to enclose the operating mechanisms. The standard cover and the miniaturized cover are similar except in size. Both consist of two parts, a top and a front panel. The top cover is designed to provide cable access and access to the main power switch at the rear of the set. There are no operating features.

FOR 4-7 SEE Change # T-1
page # 5

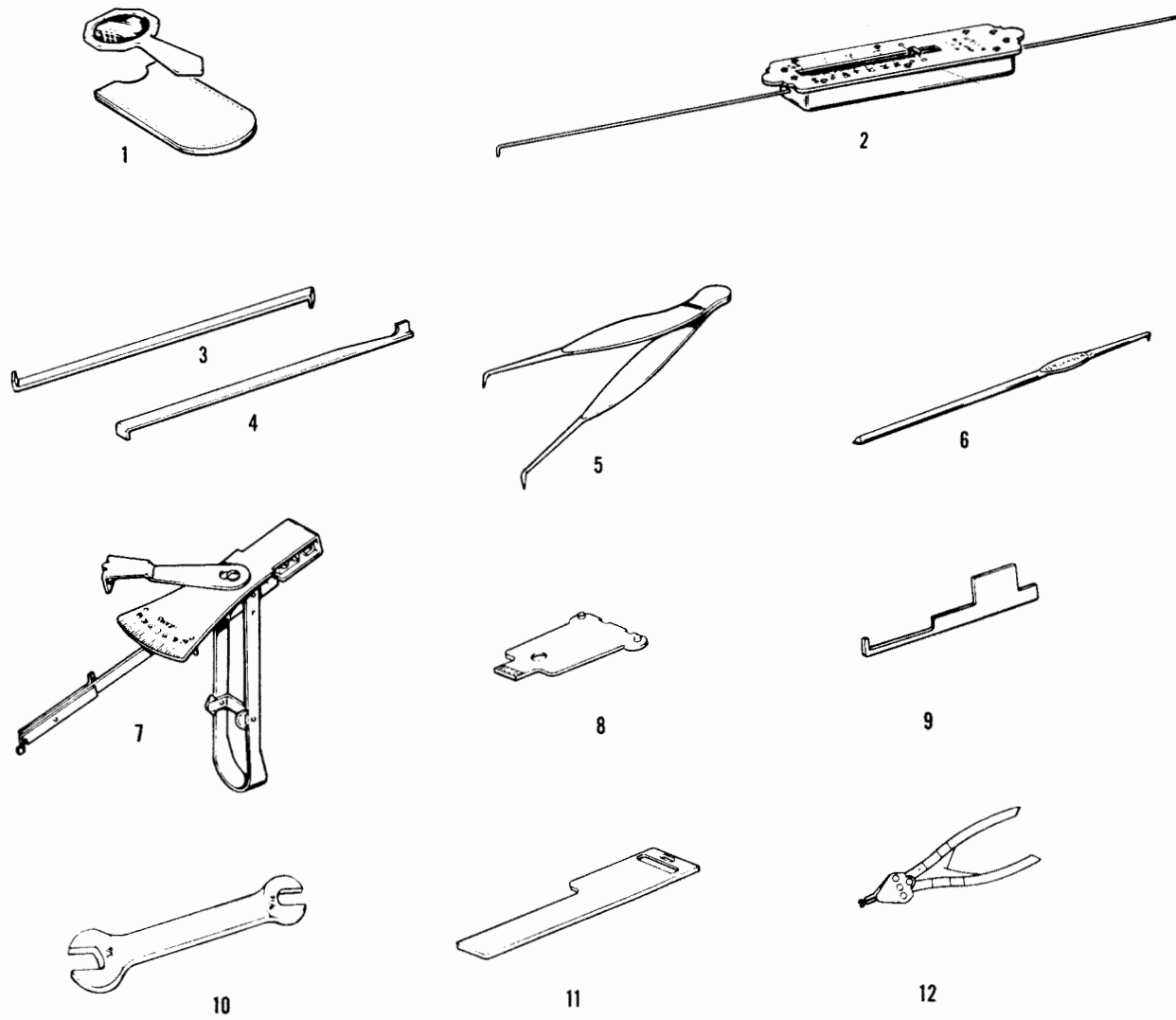

- 1. Magnifying lens
- 2. 64-oz spring scale
- 3. Offset screwdriver
- 4. Offset screwdriver
- 5. Tweezers
- 6. Spring hook pull tool

- 7. 70-gram spring scale
- 8. Tape lid gauge
- 9. Contact adjusting tool
- 10. Double end wrench
- 11. Top plate adjusting gauge
- 12. Truarc puller pliers

Figure 5-1. Tools

SECTION 5

TROUBLE SHOOTING AND PREVENTIVE MAINTENANCE

5-1. GENERAL.

a. Preventive maintenance is applied for the purpose of detecting and correcting troubles before they develop to the point of interference with satisfactory operation of the equipment. Proper lubrication, but not over-lubrication, is an important preventive maintenance measure. Use care to prevent the introduction of trouble when work on the equipment is necessary. Do not disturb adjustments unnecessarily.

b. A thorough visual inspection of the equipment during periodic checks may uncover conditions that could possibly cause trouble later. The appearance of oxidized (red) metal dust adjacent to any bearing surface may indicate insufficient lubrication. A dislodged attaching part should always be correctly identified and replaced, and all associated parts should be adjusted at once. The adjustable clearances of working parts should also be observed. A visual examination should be accompanied by a manual one. Connections at terminal boards should be checked for tightness. Nuts and screws that lock adjustable

features should be carefully observed for looseness and tightened if necessary. While cleaning the units, care should be exercised to avoid damage or distortion to delicate springs, weakening their tension. Electrical contact points should be kept free and clear of dirt, oil, corrosion or pitting. Check that operating clearance has been maintained when a contact has been cleaned.

NOTE

The attention of maintenance personnel is invited to the requirements of Chapter 67 of the Bureau of Ships Manual of the latest issue.

5-2. TOOLS.

Tool equipment TE-50-B and the tools listed in table 5-1 (see figure 5-1) are required for maintenance of Distributor-Transmitters TT-187/UG and TT-187A/UG. These tools are not supplied as parts of the equipment.

TABLE 5-1. LIST OF TOOLS.

ITEM NO. (FIG. 5-1)	TELETYPE PART NUMBER	NAVY DESIGNATION	DESCRIPTION
1	73408		Lens, magnifying; with case Bausch & Lomb Optical Code No. 06175, Part No. 81-23-40
2	82711		Scale, spring; 64 ounce
3	94644		Screwdriver, offset Western Electric Co. Code No. 64959. Part No. 206.
4	94645		Screwdriver, offset Western Electric Co. Code No. 64959. Part No. 207.
5	151392		Tweezers Samuel Harris Co. Code No. 27395. Part No. 67.
6	151959		Tool, spring hook; pull Boye Needle Co. Code No. 71111. Part No. 12.
7	152223		Scale, spring; 70 grams Western Electric Co. Code No. 64959. Part No. 68C.
8	156743		Tape lid gauge
9	156170		Contact adjusting tool
10	129537		Double end wrench
11	159133		Top plate adjusting gauge
12	160396		Truarc puller pliers Berry Bearing Co. Code No. 70788. Part No. 2-22.
13 (not illus)	DXD	TS-383B/GG	Distortion test set

TABLE 5-2. ROUTINE MAINTENANCE CHECK CHART.

WHAT TO CHECK	HOW TO CHECK	PRECAUTIONS
1. Accumulation of dust and dirt.	Clean cover by wiping with a dampened soft, lint-free cloth. Check for lint or grease beneath the path of tape through reading head. Remove transmitter mechanism top plate and dust interior with soft brush.	Avoid cleaning with air hose. Be sure that springs or other parts are not disturbed in cleaning. Avoid getting dust or dirt into bearings or other moving parts.
2. Dirty contacts and pole pieces. <i>SEE Change T-1 FOR REF</i>	Run a piece of clean paper between contacts and between pole pieces and armature.	Avoid residue of lint or torn paper after cleaning. Do not bend contacts.
3. Adjustments.	Most adjustments will remain within specification limits for the life of the equipment and, therefore, do not require checking unless trouble occurs. The following adjustments should be checked and refined if necessary. a. Signal generator, figures 6-30 and 6-31. b. Clutch, figures 6-17, and 6-18.	Avoid overtightening adjustment screws, which might result in stripping threads.
4. Lubrication. 8	For disassembly prior to lubrication, see paragraph 6-3. Remove distributor-transmitter mechanism from base. Examine for signs of lubrication failure, usually evidenced by the presence of red powdery substance at point of failure. If failure is observed, parts should be examined and if damaged, they should be replaced. Lubricate in accordance with figures 5-2 through 5-10.	Avoid overlubrication. Be sure that springs are not disengaged and that other parts are not disturbed during examination or lubrication.

5-3. ROUTINE MAINTENANCE CHECK CHART.

Routine maintenance shall be performed as directed in table 5-2.

5-4. TROUBLE SHOOTING.

a. GENERAL — Failures of the equipment can be traced functionally by means of the trouble shooting chart, table 5-3. A step-by-step analysis of the behavior of the equipment in response to tabulated checks will indicate the area of the trouble in which to apply remedial measures outlined below and referenced in the chart. Since, in most cases, each check step is conditioned by the procedure in preceding steps, examine the condition of all controls before rechecking any step or otherwise performing any trouble shooting check out of sequence. An eliminative process relative

to probable troubles indicated should facilitate clearing faulty operation at any point in the equipment. In every case where a part fails, an ELECTRONIC FAILURE REPORT, form DD787, should be prepared and forwarded to BuShips. (See paragraph 6-1.)

(1) When check of an adjustment is indicated, care should be exercised not to disturb the adjustment or related adjustments. Reference is made to adjustment illustrations in Section 6 as required. If adjustments are found to be needed, check paragraph 6-4 to determine if related adjustments may be required.

(2) For removal and repair procedures, when indicated, refer to paragraph 6-3 and to the exploded views of the equipment contained in Section 6.

(3) Comprehensive electrical analysis of equipment is generally not required in trouble shooting.

TABLE 5-3. TROUBLE SHOOTING CHART (Sheet 1 of 2 Sheets)

STEP	PROCEDURE AND NORMAL INDICATION	TROUBLE	NEXT STEP	CORRECTIONS (REF. PARAGRAPHS)
1	Main power switch ON; motor starts intermediate gear mechanism operates.	Motor does not start.	Check external power. Check main power switch. Check thermal cut-out switch.	5-4b(1)(a) 5-4b(1)(b) 5-4b(1)(c)
2	Motor runs.	Motor runs at incorrect speed.	Check power frequency.	5-4b(1)(d)
3	Intermediate gears operate.	No power to main shaft.	Check adjustment of intermediate gear.	5-4b(2)(a)
4	Tape lid button depressed; perforated tape inserted; lid closed.	Tape lid failure. Feed wheel does engage feed holes.	Check mechanical linkage and loose or missing springs. Check tape lid adjustment. Check tape guide adjustment.	5-4b(2)(b) 5-4b(2)(c) 5-4b(2)(c)
5	Start-stop lever moved to left position (FREE); tape can be positioned beneath closed tape lid.	Tape binds.	Check mechanical linkages.	5-4b(2)(d)
6	Start-stop lever in RUN position (signal output may be checked on local monitor equipment or by placing Signal Distortion Set TS-652/GG in signal line.)	Clutch does not trip. Faulty signal transmission. Garbled transmission. Transmission stops.	Check for raised tight tape bail. Check start-stop tight tape contacts. Check transfer bail, stabilizer and toggle mechanical linkages and adjustments. Verify clear, closed condition of external signal circuit. Check input tape. Check orientation of sensing pins in code holes. Check mechanical linkages. Check contact box adjustments. Check capacitor for leakage. Check main bail eccentric drive arm and trip assembly mechanical linkage. Steps 7 through 9 outline conditions for intentional interruption of transmission.	5-4b(3)(a) 5-4b(3)(b) 5-4b(4)(a) 5-4b(4)(b) 5-4b(4)(c) 5-4b(4)(d) 5-4b(4)(e) 5-4b(4)(f) 5-4b(4)(f) 5-4b(g)

TABLE 5-3. TROUBLE SHOOTING CHART (Sheet 2 of 2 Sheets)

STEP	PROCEDURE AND NORMAL INDICATION	TROUBLE	NEXT STEP	CORRECTIONS (REF. PARAGRAPHS)
7	Input tape lifted slightly at right of tape guide, to elevate tight tape bail; transmission stops.	Transmission does not stop.	Check tight tape intermediate arm linkage. Check adjustment. Check switch contacts.	5-4b(5)(a) 5-4b(5)(a) 5-4b(3)(b)
8	Depress tape lid button during transmission or feed torn end of tape through reading head; transmission stops.	Transmission does not stop.	Check tape-out sensing pin. Check mechanical operation of tape-out switch. Check tape-out switch contacts.	5-4b(5)(b) 5-4b(5)(c) 5-4b(5)(d)
9	Start-stop switch in OFF position; transmission stops.	Transmission does not stop.	Check switch.	5-4b(3)(b)

Mechanical adjustments when properly completed will in most cases insure satisfactory electrical performance. If available, a Signal Distortion Test Set TS-652/GG (used in accordance with procedures outlined in NAVSHIPS 91654) may be installed in the signal line to evaluate the quality of the signal produced by the signal generator. The following are common signal line troubles:

(a) "Open." Related teletypewriter equipment on the signal line "runs open" as a result of failure of the marking or current-on element of the signal.

(b) "Closed." Related teletypewriter equipment on the signal line "runs closed" as a result of failure of the spacing, or current-off element of the signal.

(c) "Garbling" is a condition in which the transmitted message does not correspond to the coded intelligence on the input tape.

(d) "Marking bias" advances the beginning of each marking impulse with respect to the beginning of the character cycle.

(e) "Spacing bias" delays the beginning of each marking impulse.

(f) "Marking end distortion" delays the end of each marking impulse.

(g) "Spacing end distortion" advances the end of each marking impulse.

b. ELIMINATION OF TROUBLE INDICATIONS. (See table 5-3. Follow steps in numerical order, and be sure correct procedure has been followed if indication is not normal.)

(1) MOTOR FAILURE.

(a) Check condition of external power supply, including external fuses. Check connections at terminals 7 and 9 of lower terminal board.

(b) Check condition of main power switch for mechanical failure. Check connections to terminals 8 and 9 of lower terminal board. Short terminals 8 and 9 to check electrical condition of switch.

(c) Check for open thermal cutout switch at the rear of the motor mounting bracket. If the red switch button is raised, rotate the motor manually and check mechanical linkages in the intermediate gear mechanism for an obstruction. Depress the switch button.

If the cutout operates shortly after the motor switch has been reset, allow the motor to cool for five minutes and check for the cause of overheating before resetting.

(d) If motor operates at incorrect speed, check for 60 cycle (plus or minus 0.5 cycle) frequency in the power supply.

SEE CHANGE T-1 FOR REF. TO FOLLOWING PAGE 6 PARAGRAPH

(2) DISTRIBUTOR-TRANSMITTER FAILURE.

(a) Check tightness of distributor-transmitter mounting screws. Reposition intermediate gear assembly (figure 6-34).

(b) If tape lid fails to open when the red tape lid button is depressed or fails to close when pressed down, check for missing springs in the tape lid latch mechanism. Check mechanical linkage.

(c) Check adjustments (figures 6-19 and 6-20).

(d) If tape fails to move freely through the tape guide (manually) when start-stop lever is in left or FREE position, check the mechanical linkage releasing the feed pawl detent lever from the feed wheel and depressing the tape-out sensing pin (figures 6-25, 6-26, 6-29 and 6-30).

(3) TAPE TRANSMISSION FAILURE.

(a) Check tight tape bail on front of tape guide. If tight or twisted tape has elevated the lever, correct the obstruction in the tape completely before resuming transmission attempt.

(b) Check for dirty or unadjusted normally open contacts on the start-stop tight tape switch (figure 6-25) and the tape-out contacts (figure 6-23). Burnish contacts and readjust as required.

(4) FAILURE IN SIGNAL TRANSMISSION.

(a) Check mechanical linkages of transfer lever, stabilizer and toggle (figures 6-29 and 6-30) and adjust as required.

(b) Check for clear, closed condition of external signal circuit if transmission is garbled.

(c) Check the code perforations of the input tape to be sure garbling is not on input.

(d) Check orientation of sensing pins in tape code holes (figure 6-27). Any adjustment of this requirement must be preceded by adjustment of tape guide, figure 6-19.

(e) Check mechanical linkages of transmitter mechanism for binding in sensing fingers sequence of operations to transfer bail stabilizer. Check out the particular code element linkage responsible for garbling, if possible.

(f) Check contact box adjustment, figure 6-31. Check for leakage in signal box capacitor.

(g) Check main bail eccentric drive arm and trip assembly linkage for binding or poor adjustment to allow latch lever to engage stop lever on clutch prematurely. (See figure 6-29.)

(5) TIGHT TAPE AND TAPE-OUT FAILURE.

(a) Check mechanical linkage through intermediate arm to switch for binding or maladjustment. See adjustment of tight tape intermediate arm and switch, figure 6-25.

(b) Check for binds in mechanical linkage of tape-out sensing pin (figure 6-24). Note in particular that the pin clears the aperture in the tape guide plate. Adjust per figure 6-24 as required.

(c) Check mechanical linkage of tape-out sensing pin and tape-out switch and adjust switch bracket as required. See figure 6-23.

(d) Check for sticking or badly adjusted contacts in the normally closed tape-out switch. Burnish and readjust contacts per figure 6-23.

5-5. LUBRICATION.

a. Lubricate the teletypewriter as directed in figures 5-2 through 5-10, inclusive. These figures indicate the points to be lubricated and the type and quantity of lubricant to be used. Lubricate the teletypewriter just prior to placing it in service. After a few weeks in service, relubricate to make certain that all points receive lubricant.

b. In service, the following lubrication schedule should be followed:

OPERATING SPEED (Words per Minute)	LUBRICATING INTERVAL (Whichever Occurs First)
60	3, 000 hours or 1 year
75	2, 400 hours or 9 months
100	1, 500 hours or 6 months

c. For normal or high temperatures (5° to 55°C; 41° to 131°F) use Teletype KS-7470 oil at all locations where the use of oil is indicated. For lower temperatures, dilute the KS-7470 oil with kerosene (half and half). Use type MIL-G-3278 grease on all surfaces where grease is indicated, except the motor bearings. Apply two drops of KS-7470 oil to motor bearings of the large motors every four months and six drops to the miniature motor every 750 hours of operation or every three months whichever occurs first (depress oiler with metal object). If the motor is disassembled at any time, repack the bearings with MIL-C-3278 grease.

d. All springs, wicks and felt oilers should be saturated. The friction surfaces of all moving parts should be thoroughly lubricated. Overlubrication, which will permit oil or grease to drip or be thrown on other parts, should be avoided.

e. Exercise special caution to prevent any oil or grease from getting between the armatures and the pole pieces of the selector magnets, the distributor-transmitter clutch magnets, the tape back space magnets or the tape feed-out magnets. Electrical contact surfaces must be kept free of oil.

f. Apply a thick film of grease to all gears and to the spacing clutch reset cam plate. When gear changes are made to change operating speed of the components, lubricate the replacement pinion and gear when the change is made.

g. For visual identification, instruction has been keyed to a photograph of the equipment. The first digit is a hyphenated numeral corresponding to the figure number in which the photograph will be found. The second digit in the key is a letter to indicate the reference point on that photograph. (For example, 5-2(A) is a lubrication instruction for a part illustrated photographically in figure 5-2, and at point (A) on that figure.)

h. Specific lubricant requirements and the amount of lubricant are indicated at each lubrication instruction in accordance with the following code:

O	Apply 1 drop of KS-7470 oil
O2	Apply 2 drops of KS-7470 oil
O3	Apply 3 drops of KS-7470 oil
O20	Apply 20 drops of KS-7470 oil
SAT	Saturate (felt oilers, washers, wicks) with KS-7470 oil
G	Apply thin film of MIL-G-3278 grease

i. Lubricate according to the applicable lubrication instructions whenever parts or assemblies are removed and reassembled, or when handling the equipment for adjustment purposes may have removed some or all of the lubricant.

NOTE

During each lubrication period, check the following adjustments:

Tape-out contact assembly, figure 6-23.
Start-stop switch bracket, figure 6-25.

5-2A TT-147/UG MOTOR AND INTERMEDIATE GEAR MECHANISM

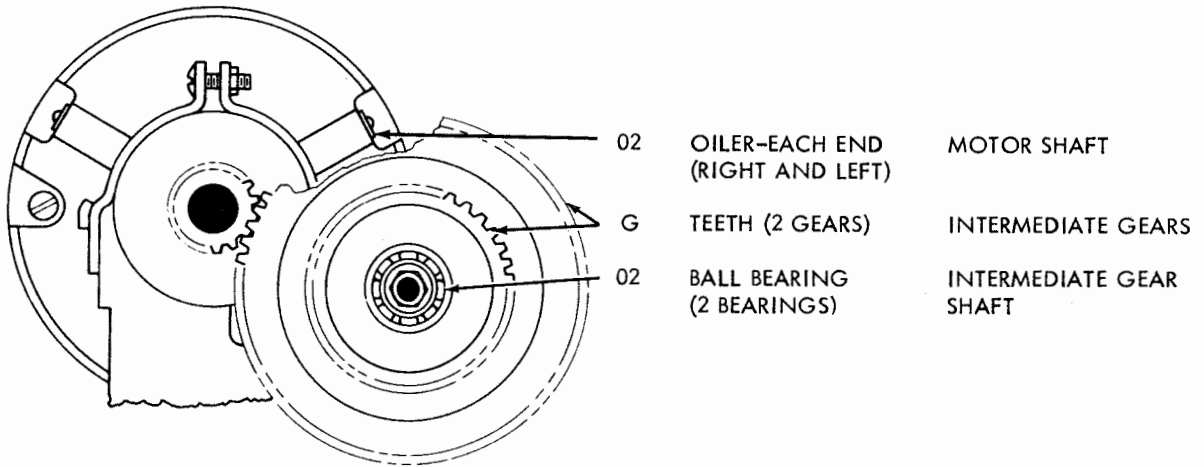

5-2B TT-147A/UG MOTOR AND INTERMEDIATE GEAR MECHANISM

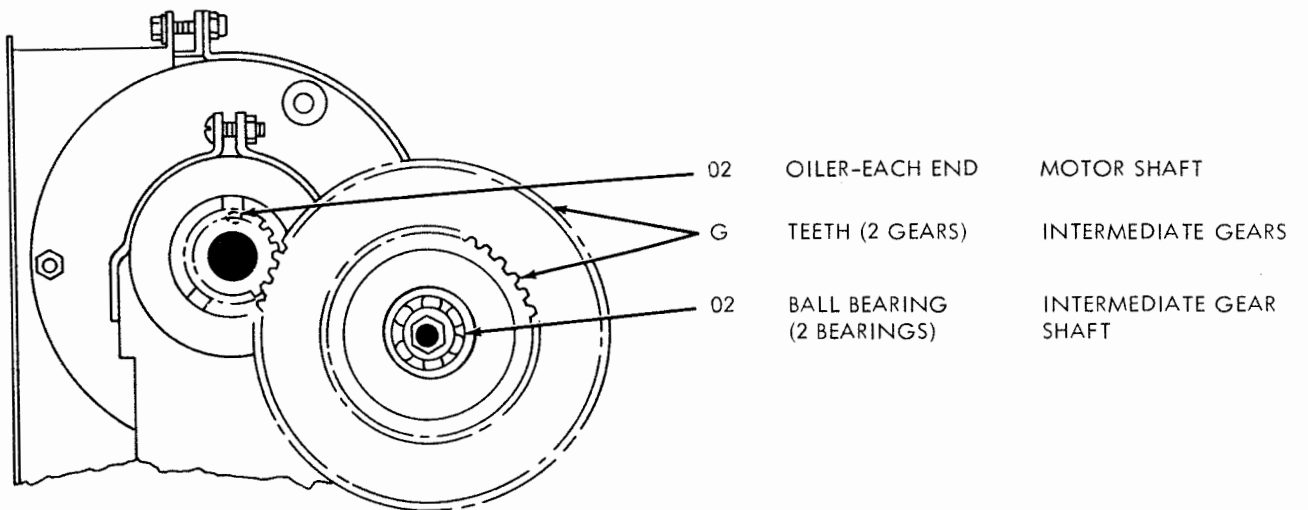
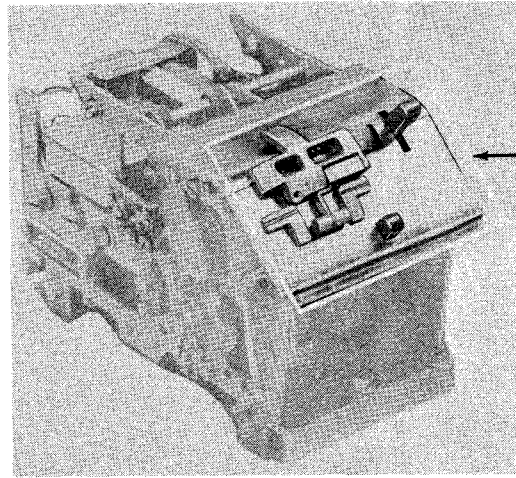

Figure 5-2. Motor and Base Lubrication



5-3(A)

5-3(A) TAPE GUIDE PLATE

(TOP VIEW)

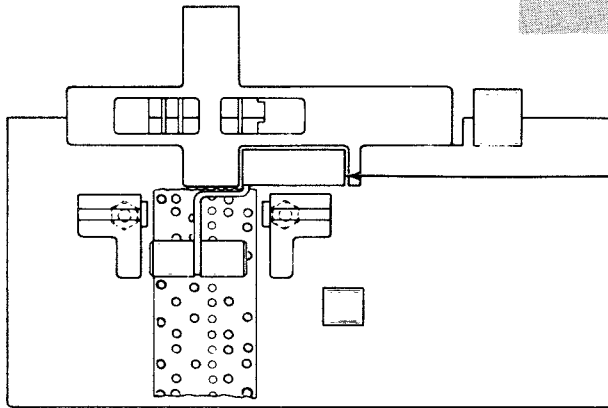

○ BEARING SURFACE TIGHT TAPE BAIL

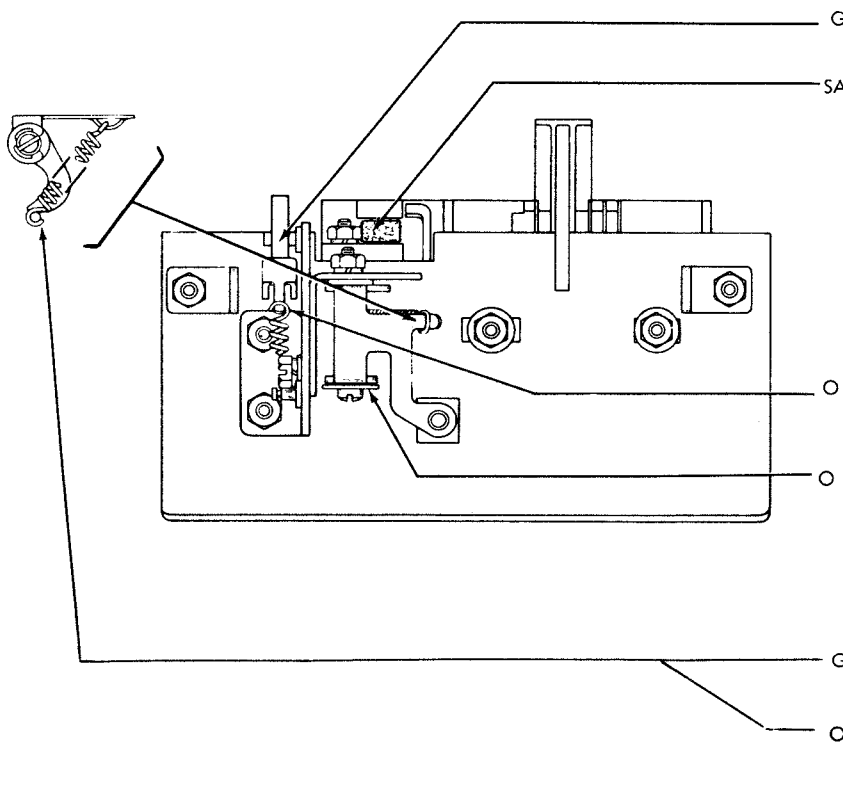

G TEETH START-STOP LEVER

SAT FELT WASHER TAPE LID SHAFT

○ EACH LOOP START-STOP DETENT BAIL

○ BEARING SURFACE TAPE LID RELEASE BAIL

G LATCHING SURFACE TAPE LID LATCH

○ EACH LOOP TAPE LID LATCH SPRING

Figure 5-3. Tape Guide Plate

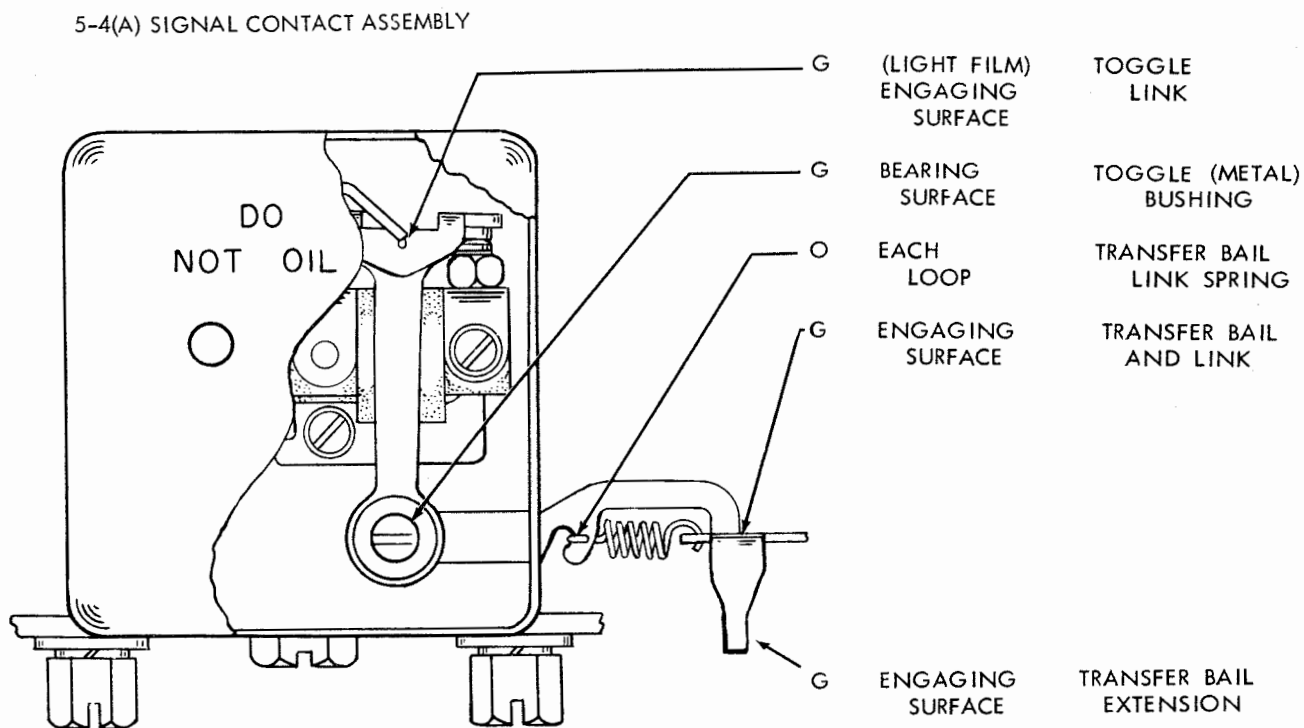
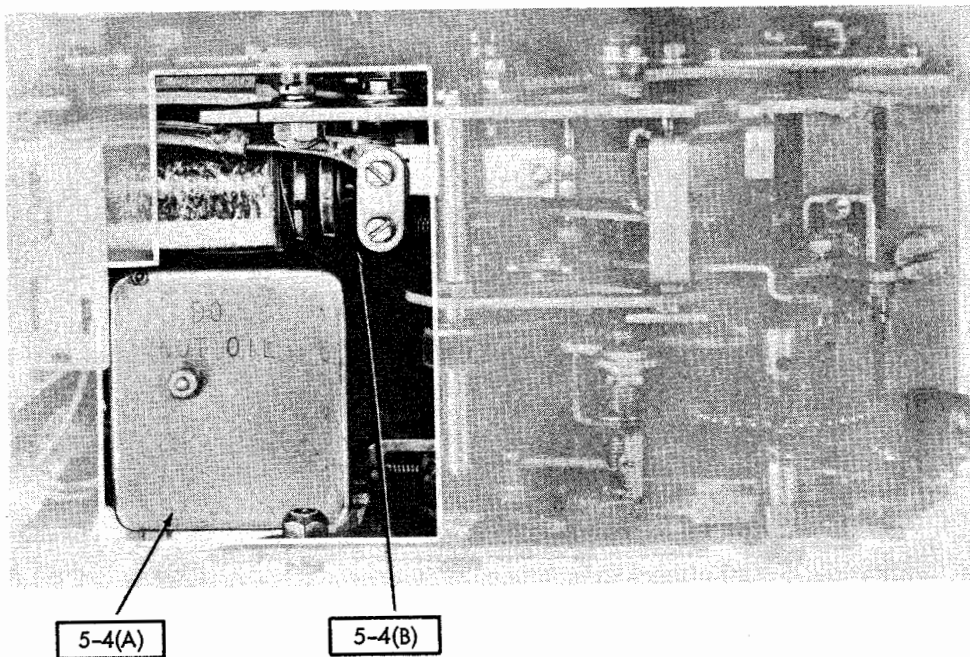

Figure 5-4. Signal Contact Assembly

5-4(B) CLUTCH TRIP ASSEMBLY

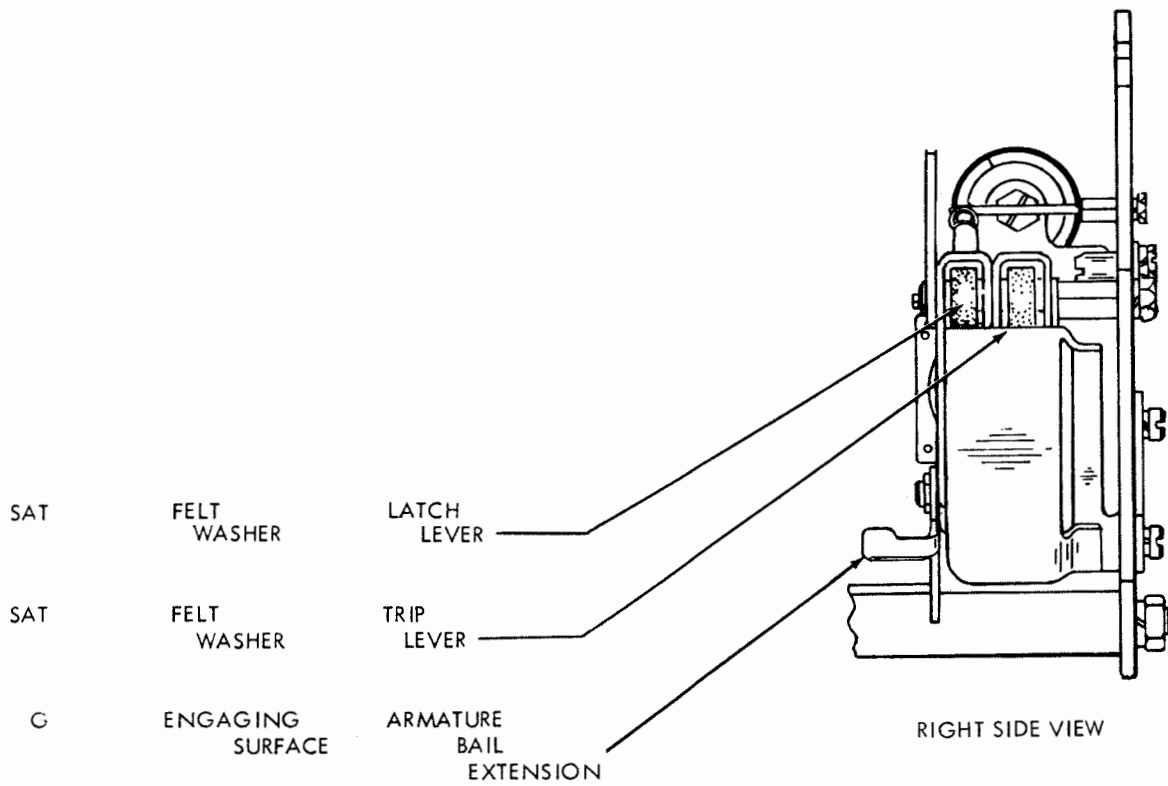
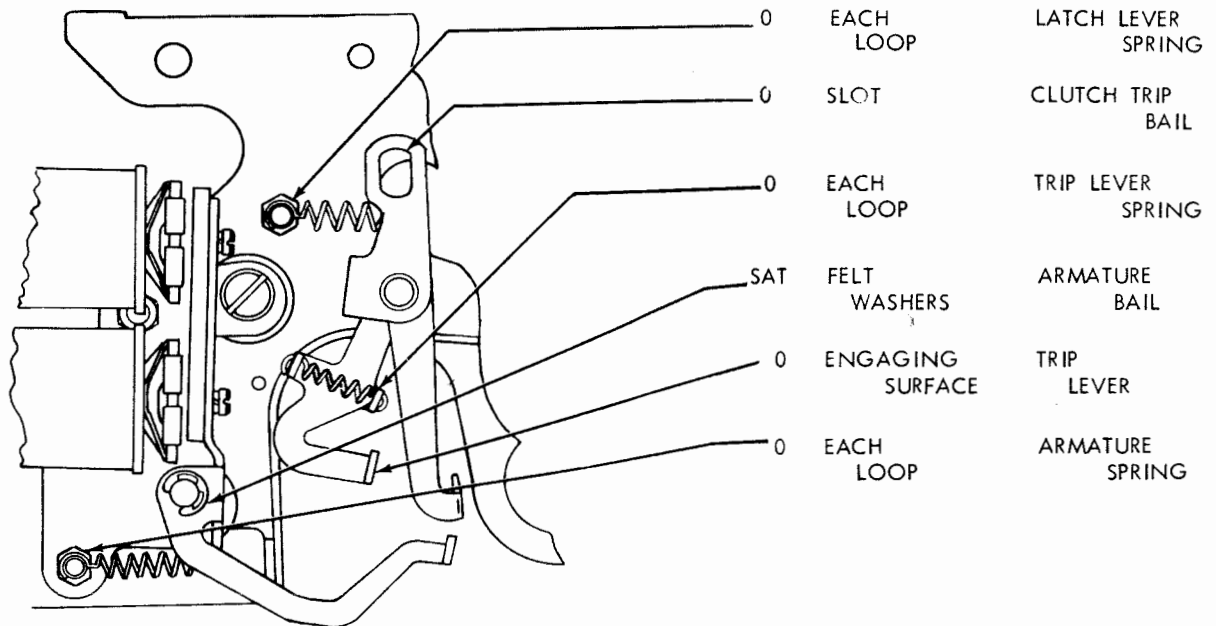

Figure 5-5. Clutch Trip Mechanism

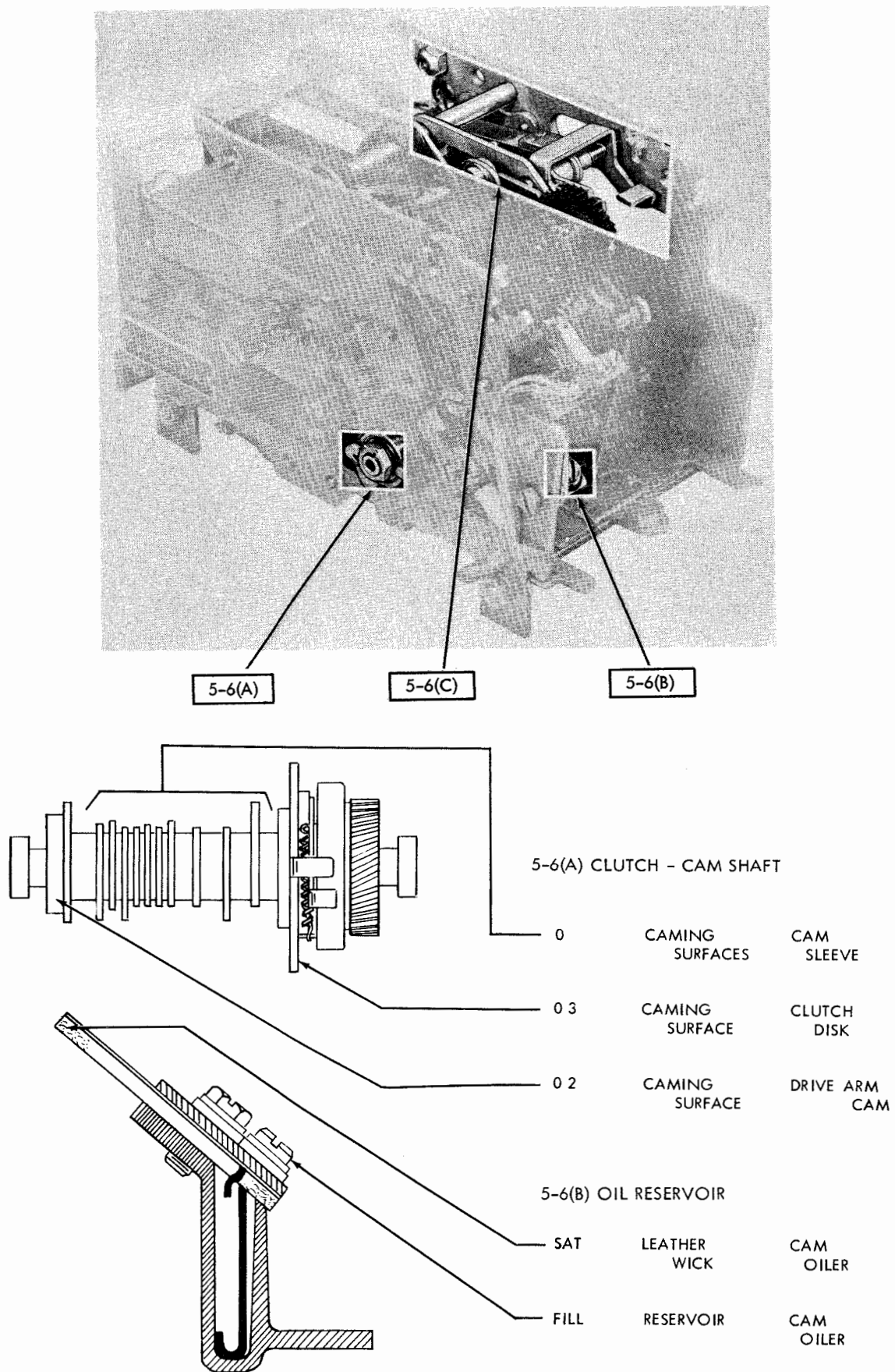

Figure 5-6. Main Shaft and Oil Reservoir

5-6(C) CENTER PLATE ASSEMBLY

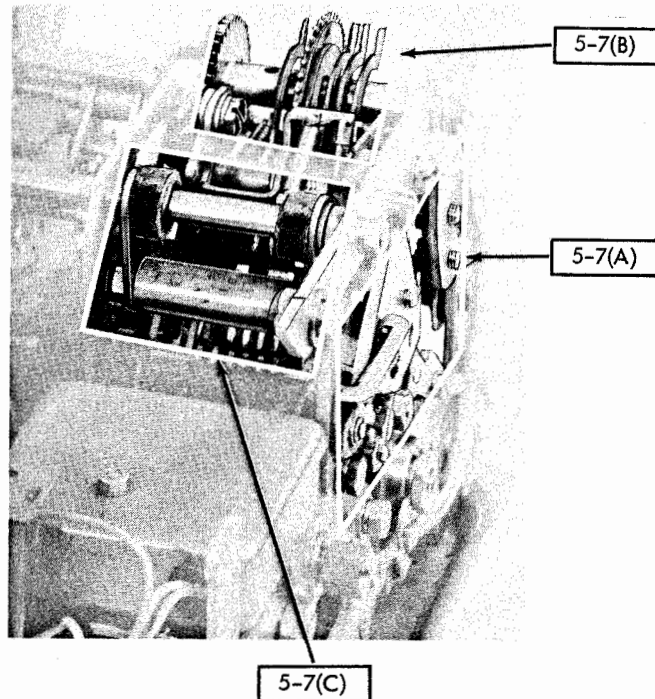
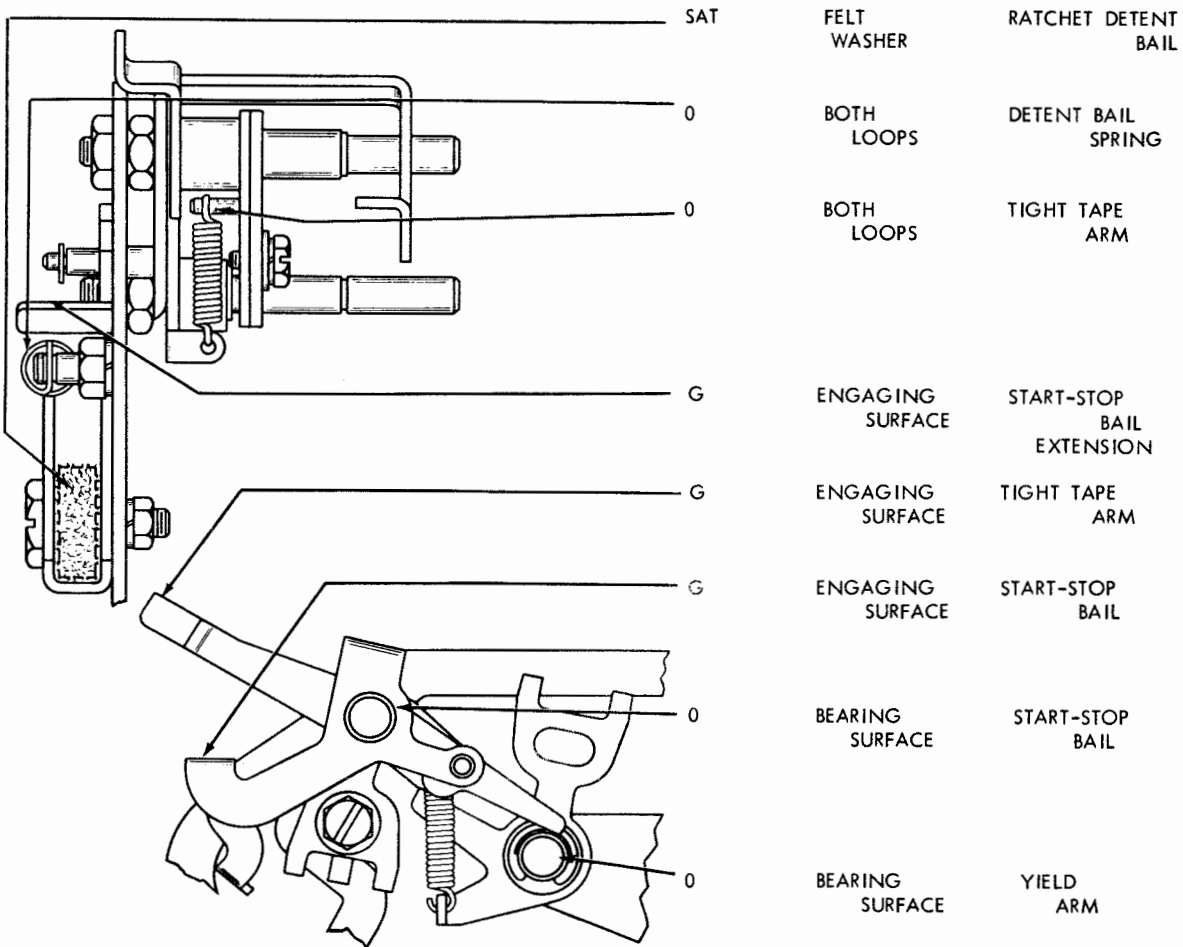

Figure 5-7. Center Plate Mechanism

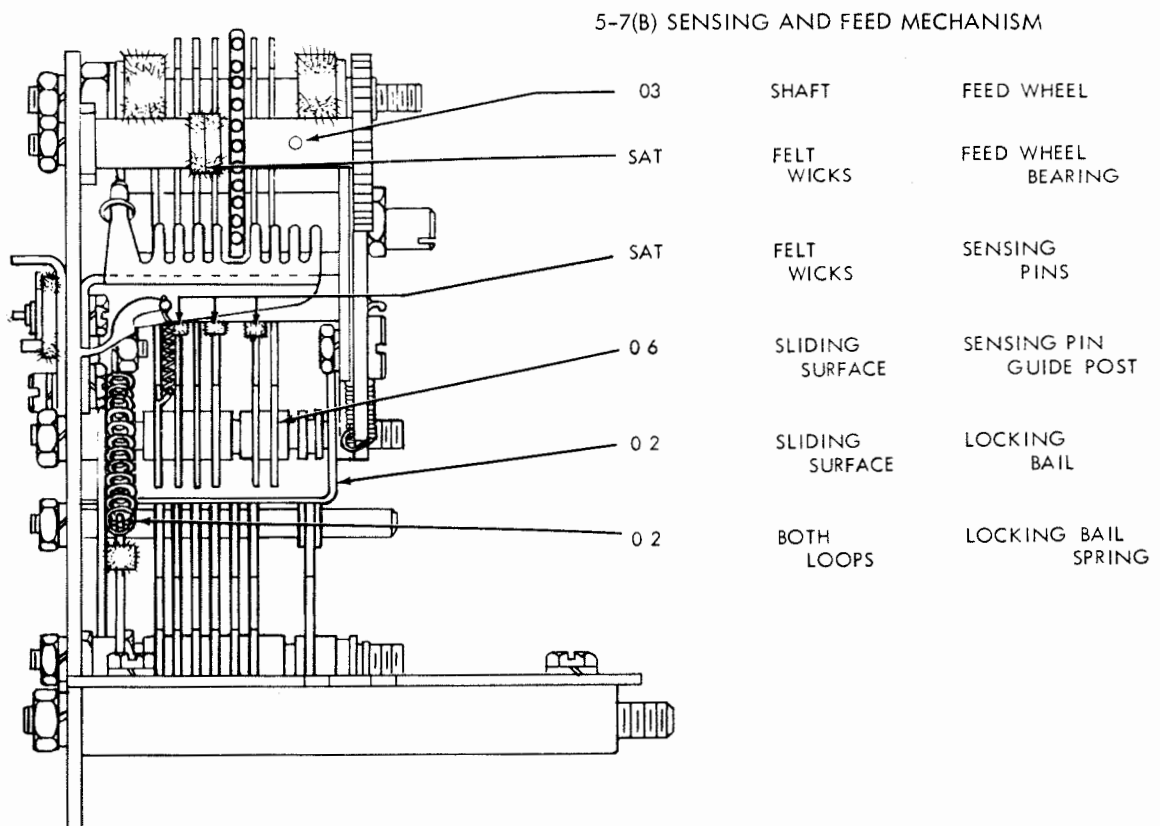
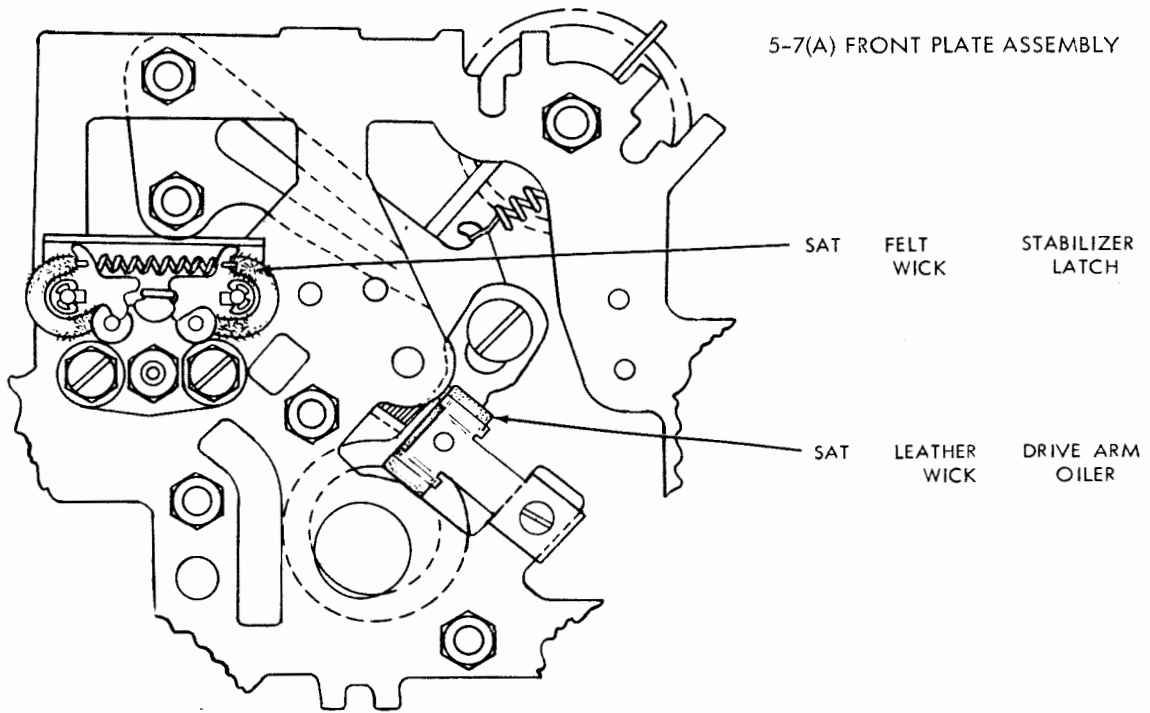

Figure 5-8. Front Plate, Sensing and Feed Mechanism

5-7(C) TRANSFER MECHANISM

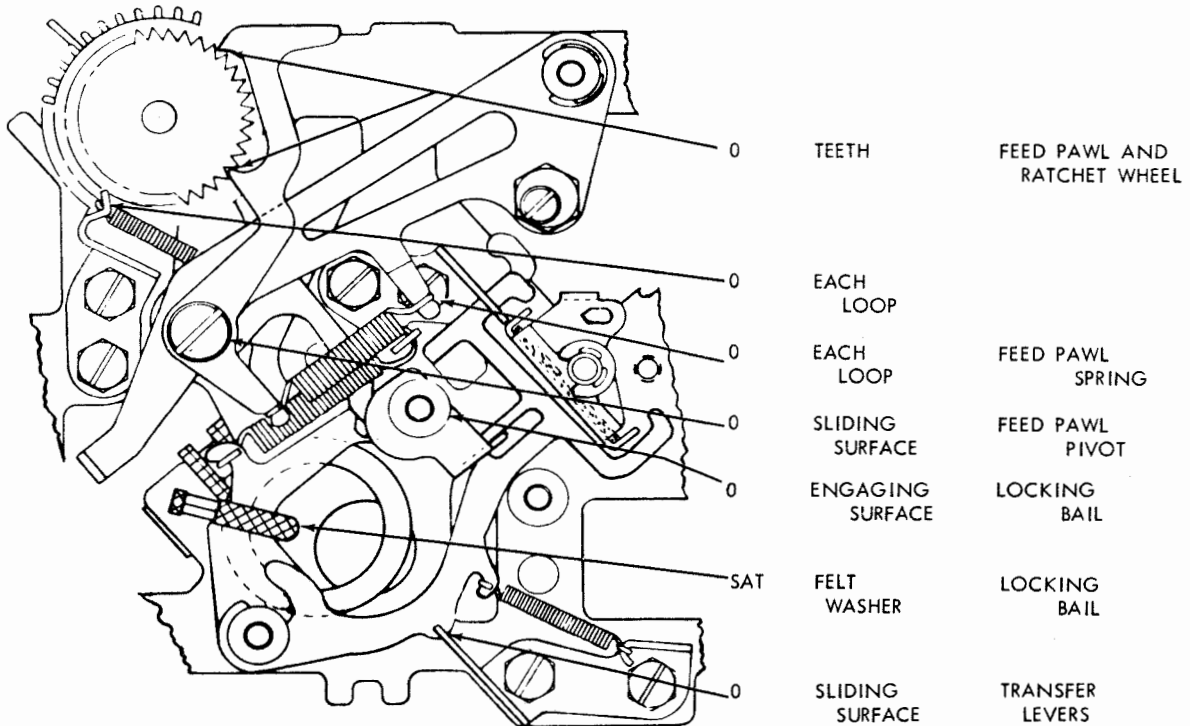
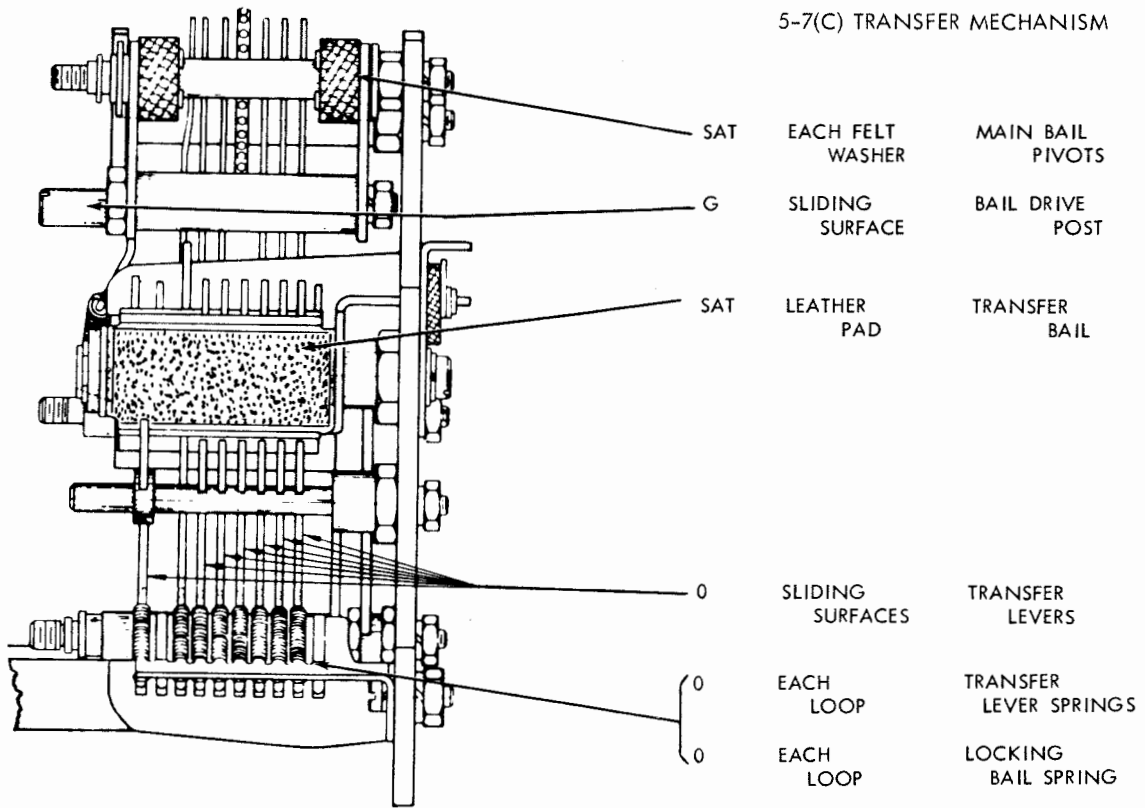

Figure 5-9. Transfer Mechanism

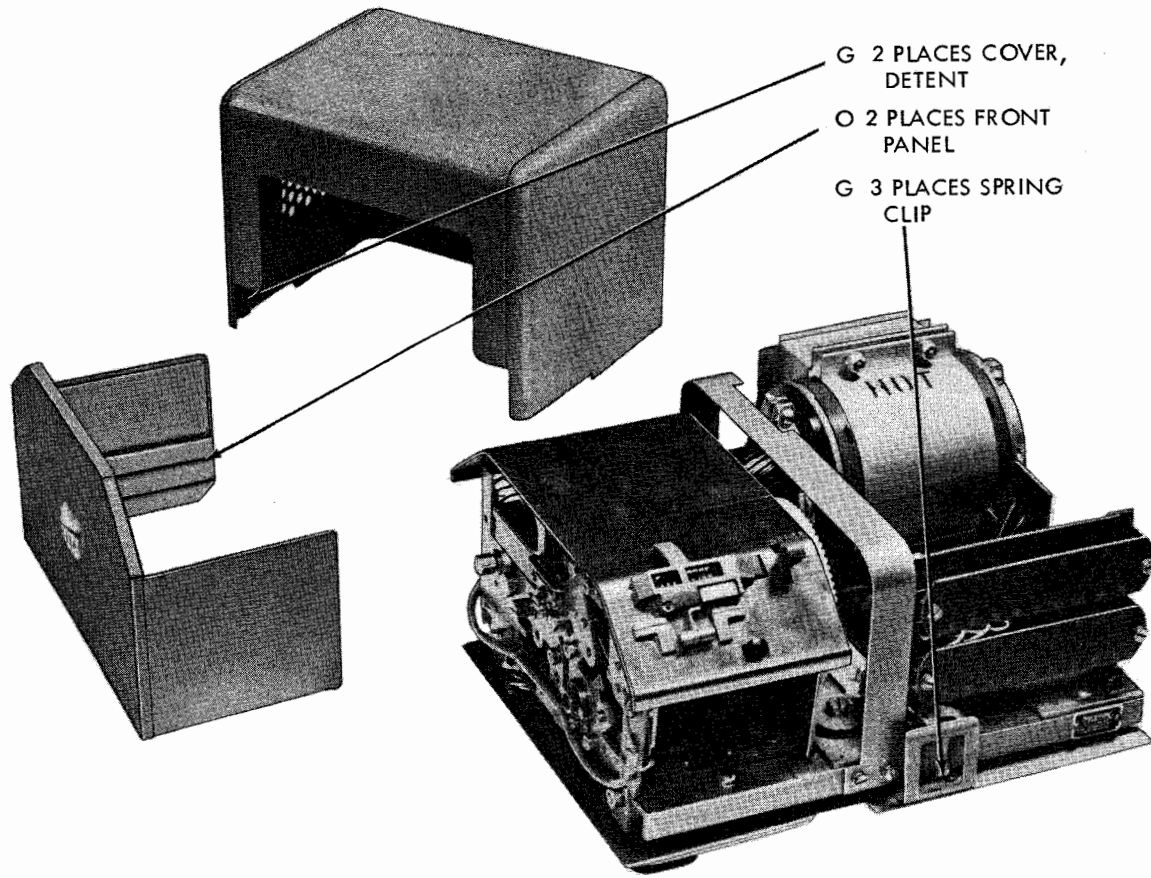
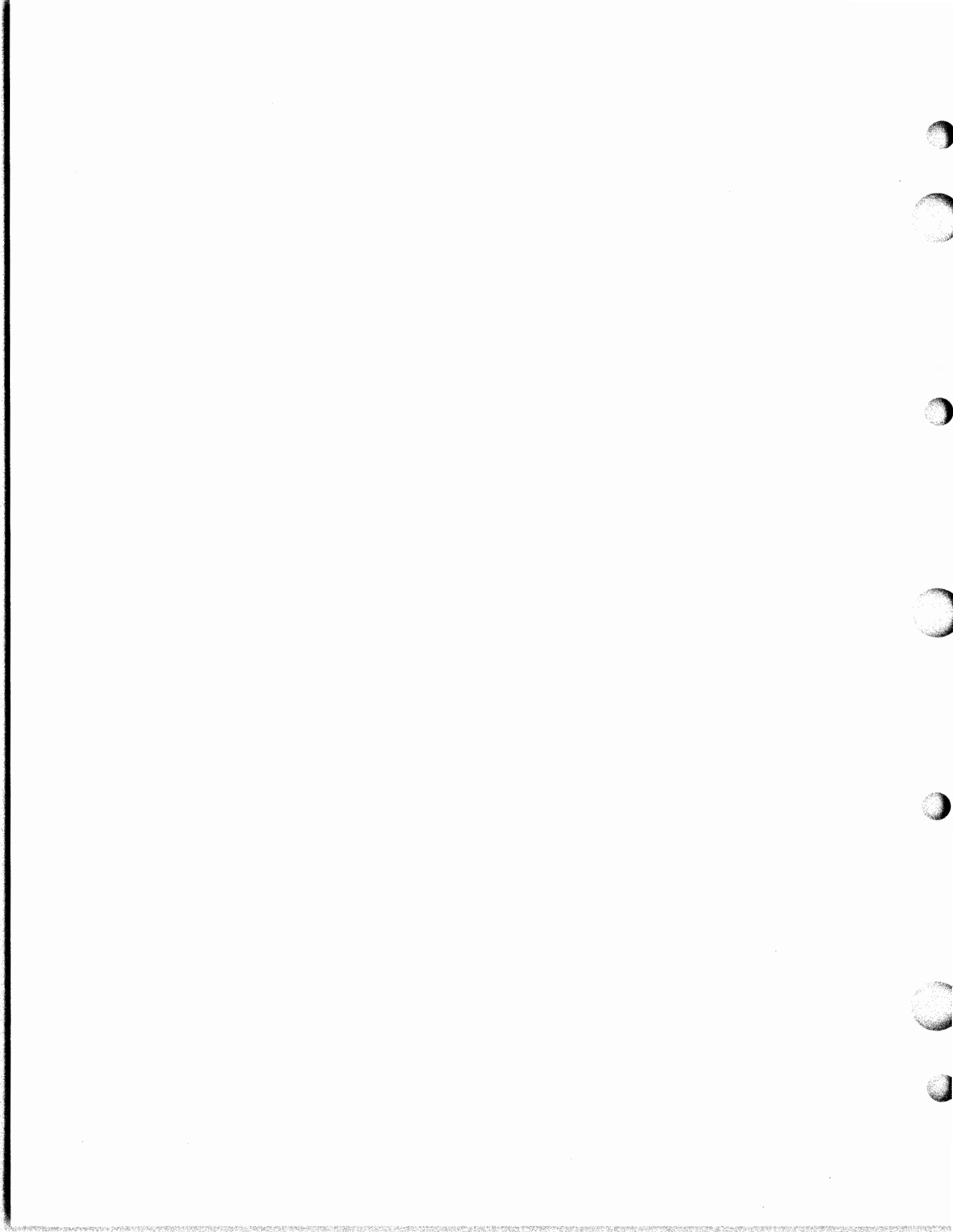

Figure 5-10. Cover and Base Lubrication



SECTION 6 SERVICE AND REPAIR

6-1. FAILURE REPORT.

Report each failure of the equipment, whether caused by a defective part, wear, improper operation, or an external cause. Use ELECTRONICS FAILURE REPORT form DD787. Each pad of the forms includes full instructions for filling out the forms and forwarding them to the Bureau of Ships. However, the importance of providing complete information cannot be emphasized too much. Be sure that you include model number and serial number of the equipment (from the equipment identification plate), the type number and serial number of the major unit (from the major unit identification plate), and the type number and reference designation of the particular defective part (from the technical manual). Describe the cause of the failure completely, continuing on the back of the form if necessary. Do not substitute brevity for clarity. And remember — there are two sides to the failure report —

YOUR SIDE

Every FAILURE REPORT is a boost for you:

1. It shows that you are doing your job.
2. It helps make your job easier.
3. It insures available replacements.
4. It gives you a chance to pass your knowledge on to every man on the team.

Always keep a supply of failure report forms on board. You can get them from the nearest Forms and Publications Supply Post.

BUREAU SIDE

The Bureau of Ships uses the information to:

1. Evaluate present equipment.
2. Improve future equipment.
3. Order replacements for stock.
4. Prepare field changes.
5. Publish maintenance data.

6-2. GENERAL.

a. The information in this section is planned so as to provide maintenance personnel with effective means for location and clearing trouble. It is necessary that the technicians be thoroughly familiar with the theory of operation of the equipment (Section 4) and with the adjusting routine (paragraph 6-4) before attempting any maintenance procedures.

b. Exploded illustrations, figures 6-1 through 6-15, are grouped on a functional basis, insofar as possible. They are keyed to the Maintenance Parts List, Table 7-2, by their reference designations. See table 7-1 for the systematic assignment of reference designation numbers to the major components. The arrangement of the major components in the exploded illustrations is as listed below:

Component	Figure
Cover	6-1
Cover, Miniaturized	6-1
Base.	6-2, 6-4
Base, Miniaturized.	6-2 through 6-4
A.C. Motor	6-5
A.C. Motor, Miniaturized	6-6
Distributor-Transmitter	6-7 through 6-15

c. Tools required for service and repair, including removal and replacement of parts and assemblies and adjustment, are listed in table 5-1. These are not supplied as part of the equipment.

6-3. REMOVAL AND REPAIR.

a. GENERAL. — Refer to the appropriate exploded view illustration for location and visual identification of parts and detailed disassembly and reassembly features. Refer to table 7-2, List of Maintenance Parts, for nomenclature and reference information. Most maintenance, lubrication, and adjustment can be accomplished by removing the major components from the equipment. Insofar as possible, further disassembly should be confined to assemblies, which can frequently be removed without disturbing adjustments. When reassembling assemblies, be sure to check all adjustments, clearances and spring tensions (paragraph 6-4).

NOTE

If a part is mounted on shims, the number of shims used at each of its mounting screws should be noted at the time of removal, so that the same shim pile-up can be replaced

when the part is reassembled. Retaining rings are of spring steel and have a tendency to release suddenly. Hold the ring with left-hand to prevent rotation, and place the blade of a suitable screwdriver in one of the slots of the retaining ring. Rotate the screwdriver in the direction to increase the diameter of the retaining ring. It will come off easily without springing. Avoid loss of springs in disassembly by holding one spring loop with the left-hand while gently removing the opposite loop with a spring hook or suitable probe. Do not stretch or distort springs in removal.

(1) Turn the main power switch to OFF position (down) before removing the cover or front panel.

(2) If there is an external power control, shut off external power before removing base mounted components. This precaution is not necessary, however, for removal of the distributor-transmitter mechanism on the miniaturized set, TT-187A/UG, which is equipped with a quick disconnect plug.

b. COVER (See figure 6-1.) — There are no attaching parts to be removed in removing the cover. The lower corner of the rear edges of the front panel are flanged so they can be spread to release the slots detented on the transmitter mechanism. Pull the front panel forward to remove. Lift the rear cover free of the gear guard and terminal boards. To reassemble, reverse the order used in disassembly.

c. MOTOR. (See figures 6-5 and 6-6.) — Disconnect motor leads at terminals 8 and 9, TB202. Remove four screws and lock washers, H206 and H207 or H306 and H307 and remove the motor from the base.

(1) TT-187/UG. — Remove the pinion gear from the motor shaft by removing two posts, H401. Remove the rubber pinion retainer, O401, by stretching until it is dislodged from the mounting holes of the gear. Disassembly of the motor is as shown in figure 6-5.

(2) TT-187A/UG. — Remove the pinion gear from the motor shaft by removing two posts, H401. Remove the rubber pinion retainer, O401, by stretching until it is dislodged from the mounting holes of the gear. Disassembly of the motor is as shown in figure 6-6.

(3) To reassemble and install the motor, reverse the procedure followed in disassembly. Motor leads are interchangeable.

d. DISTRIBUTOR-TRANSMITTER. (See figures 6-7 through 6-15.) — Check preliminary procedures suggested in paragraph 6-3a. Remove the cover front panel (paragraph 6-3b). Remove three screws, lock washers and washers, H601, H602 and H603, to remove the mechanism from the base. The standard distributor-transmitter (TT-187/UG) may then be removed to the extent permitted by the cable. If

further mobility is required, disconnect the cable at terminal boards TB201 and TB202. The miniaturized unit (TT-187A/UG) is equipped with a quick disconnect plug mated to a connector on the base. Lift the mechanism from the base to disconnect the cable and close the line shunt switch (S311). On the standard distributor-transmitter, remove screw, lock washer and washer H218, H219 and H220 to remove cable clamp H233 and release the cable from the base.

(1) COVER PLATE. (See figure 6-7.) — Lift upward on the left edge of cover plate A701 to unlatch spring detents O702, and pull to the left to release spring catches on O701. Disassemble as indicated in figure 6-7. Reassemble in the reverse order of disassembly.

(2) TOP PLATE. (See figure 6-7.) — Loosen two screws, lock washers and washers H707, H708 and H709, and lift the top plate from the distributor-transmitter. Disassembly is shown in figure 6-7. Reassemble in the reverse order of disassembly.

(3) TAPE GUIDE PLATE. (See figure 6-8.) — Loosen two screws, lock washers and washers H751, H752 and H753, and lift the tape guide plate and attached mechanisms from the distributor-transmitter. Disassembly is shown in figure 6-8. To reassemble and install, reverse the procedure used in disassembly.

(4) REAR PLATE ASSEMBLY. (See figures 6-9 and 6-10.) — Remove the distributor-transmitter from the base (paragraph 6-3d), and remove the cover, top and tape guide plates (paragraphs 6-3d(1) through (3)).

(a) Remove two nuts and lock washers H815 and H816. Remove screw and lock washer H875 and H876 (figure 6-11). Pull the rear plate assembly from the distributor-transmitter to the extent permitted by leads to the magnets and the start-stop tight tape switch.

(b) To remove the assembly completely, remove two screws, lock washers and washers H801, H802 and H803, and remove switch S800. Removal of the switch leads requires disassembly of the switch. See figure 6-9. Tag and disconnect four magnet leads by removing four screws and washers H867 and H868.

(c) Disassemble the rear plate assembly as indicated in figures 6-9 and 6-10.

(d) To reassemble, reverse the procedure used in disassembly. The slotted arm of bail O806 (figure 6-82) must engage eccentric O923 (figure 6-12).

(5) CENTER PLATE MECHANISM. (See figure 6-11.) — Remove the rear plate assembly (paragraph 6-3d(4)).

(a) Disconnect clutch latch spring O907 (figure 6-12).

(b) Remove spacer O875 (figure 6-11) and nut and lock washer H912 and H913 (figure 6-12). Remove the center plate mechanism.

(c) Disassembly is as shown in figure 6-11.

(d) To reassemble and install, reverse the procedure used in disassembly.

(6) MAIN SHAFT. (See figure 6-14.) — Remove the rear plate assembly (paragraph 6-3d(4)).

(a) Remove screw and lock washer H971 and H972 to remove bearing retainer A950 (figure 6-13). Rotate the shaft assembly to clear the cams, and withdraw the shaft from the rear of the distributor-transmitter.

(b) Disassembly of the main shaft is as indicated in figure 6-87.

(c) To reassemble and install, reverse the procedure followed in removal.

(7) CONTACT BOX ASSEMBLY. (See figure 6-15.) — Remove the cover plate (paragraph 6-3d(1)).

(a) Remove nut and lock washer H1028 and H1029, and lift cover A1025 from the contact box. Disconnect spring O1025.

(b) Tag and disconnect signal line leads by removing two screws H1032 and H1033 and lock washer H1034.

(c) Remove two screws, lock washers and washers H1025, H1026 and H1027, and lift the contact box from the front plate A1005.

(d) Disassembly of the contact box is shown in figure 6-15.

(e) Reassembly is the reverse of disassembly.

(8) FRONT PLATE MECHANISM. (See figures 6-12 and 6-13.) — Remove the rear plate assembly, center plate mechanism, main shaft and contact box (paragraphs 6-3d(3) through (7)). The remaining mechanisms in the distributor-transmitter are associated with the front plate A1005 (figure 6-12) and are disassembled as shown in figures 6-12 and 6-13. To disconnect leads to the tape-out switch, remove screws and lock washers H973 and H974 and nut plate A951 to detach the switch bracket A952, adjusting bracket O968, bushing O967 and spacer A975, all of which are part of the switch assembly S950 (figure 6-13). Removal of the leads requires disassembly of the switch as indicated in that figure. To reassemble the front plate mechanism, reverse the procedure followed in disassembly.

(9) To reassemble the distributor-transmitter, reverse the procedure used in removing the component mechanisms. Be sure the tip of the tape-out sensing pin O916 (figure 6-12) rides through the

aperture for it in the tape lid and that the upper extension of the pin rides under the swinger E953 of switch S950 (figure 6-13). The sensing pins, O915 (figure 6-85), should be centered in their slots on the top plate A704. If the clutch lever is tripped, the pins will extend in above the installed position of the tape guide plate and cover plate, and assembly will be easier than if clutch is latched. (See figures 6-21 and 6-22.)

e. BASE. (See figures 6-2 through 6-4.) — Remove the cover, motor and distributor-transmitter (paragraphs 6-3b through 6-3d). Disconnect external cable connections to terminal board TB202.

CAUTION

Be sure external power supply is off before disconnecting base cabling. The signal line should also be shunted externally to avoid interference with other equipment on the line while the distributor-transmitter is out of service.

(1) TT-187/UG. (See figures 6-2 and 6-4.) — Remove two screws, lock washers, washers and cable clamps H218, H219, H220 and H217 to separate signal and power input cables from the base. Remove the intermediate gear assembly, disassembling as shown in figure 6-4. Disassemble the base as indicated in figure 6-2.

(2) TT-187/UG. (See figures 6-3 and 6-4.) — Remove the intermediate gear assembly, disassembling as shown in figure 6-4. Disconnect cable W302 from terminal boards TB201 and TB202, and remove the line shunt switch S311 and connector P301 as shown in figure 6-3. Disassembly of the base is as indicated in figures 6-2 and 6-3.

(3) Reassemble the base in the reverse order of disassembly.

6-4. ADJUSTMENTS.

a. GENERAL.

(1) ADJUSTMENT SEQUENCE. — The adjustments of the distributor-transmitter are arranged in a sequence that would be followed if a complete readjustment of the equipment were undertaken. Component adjustments described in paragraph 6-4b may be made in sequence within the component, providing any cross references to related components are observed. Where an adjustment, tolerance or spring tension occurs more than once in the equipment, it has been illustrated only once, in its first sequential occurrence in a complete adjustment of the equipment. Subsequent occurrences are cross referenced to the first description of that adjustment.

(2) ILLUSTRATION ORIENTATION. — It is assumed that the mechanisms depicted in the illustrations are viewed from a position in front of the equipment, unless the illustration is specifically identified

as another view. References in the text to "left" or "right" designate the viewers left or right as he faces the front of the fully assembled equipment.

(3) DATA FURNISHED. — The adjusting illustrations, in addition to indicating the adjustment tolerance, positions of moving parts and spring tensions, also show the angle at which a scale should be applied in measuring spring tensions. The spring tensions given are indications (not exact values) and should be checked with proper spring scales in the position indicated. Springs which do not meet the requirement and for which no adjusting procedure is given should be replaced by new springs.

(4) TOOLS. — Tools required to make the adjustments and test the spring tensions are listed in table 5-1. These tools are not supplied with the teletypewriters but are available as accessory equipment.

(5) REMOVAL OF MECHANISMS. — Where adjustment instructions call for removal of components, assemblies, sub-assemblies, or parts, refer to Removal and Repair, paragraph 6-3. If parts are removed, all adjustments which the removal of these parts might facilitate should be made before the parts are replaced, or as the equipment is reassembled. When a part mounted on shims is removed, the number of shims at each mounting screw should be noted, so that the identical pile-ups can be made when the part is replaced. Unless it is specifically stated to the contrary, after an adjustment has been made, all nuts and screws that were loosened should be tightened.

(6) ELECTRICAL CONTACTS. — All contact points should meet squarely. Contacts with the same diameter should not be out of alignment more than 25 percent of the contact diameter. Always check contacts for pitting or corrosion and clean or burnish contacts before making a specified adjustment or tolerance measurement. Avoid sharp kinks or bends in the contact springs.

(7) CLUTCH. — When the requirement calls for the clutch to be DISENGAGED, the clutch shoe lever must be fully latched between the trip lever and latch lever, so that the clutch shoes release their tension on the drum. When ENGAGED, the clutch shoe lever is unlatched, and the clutch shoes are wedged firmly against the clutch drum.

NOTE

When clutch shafts are rotated manually, the clutch will not fully disengage. Where a procedure calls for disengagement, rotate the clutch to its top position, apply a screwdriver to the cam disk stop lug, and turn

the disk in the normal direction of shaft rotation until the latch lever seats in its notch in the disk.

(8) MANUAL OPERATION. — When an adjustment requirement calls for setting up a static equivalent of any operational cycle, the components may be operated manually. Rotate the input shaft in the direction it would rotate under power. This may be determined by tracing shafts and gear trains to the applicable motor. The direction of rotation of the motor shaft is clockwise, as viewed from the pinion end of the motor.

(9) THERMAL CUTOFF SWITCH. — Should the rotor of the synchronous motor become blocked for several seconds, due to an overload, the thermal cutoff switch will interrupt power to the motor until the manual reset button is depressed. Allow at least 5 minutes for the motor to cool before attempting to reset the switch and start the motor.

b. COMPONENT ADJUSTMENT SEQUENCES.

(1) DISTRIBUTOR-TRANSMITTER. — The standard adjustments for the distributor-transmitter are described in figures 6-16 through 6-33. The line shunt switch operating screw adjustment (figure 6-33) is applicable only to TT-187A/UG units.

(2) BASE. — The standard adjustments for base mechanisms are described in figures 6-33 and 6-34. The line shunt switch adjustment (figure 6-33) is applicable only to TT-187A/UG units.

(3) MOTOR. — The synchronous motor requires no adjustment. Check the reset button (paragraph 6-4a(9) if the motor does not operate. If the operating speed is incorrect, check the externally supplied a.c. power, which must be furnished at 60 cycle frequency, plus or minus 1/2 cycle.

SEE T-1 FOR REF. TO FOLLOWING
(4) COVER. — There are no operating parts to the cover to require adjustment. It may, however, be necessary to bend the clips at the bottom of the cover (TT-187/UG, 4 clips; TT-187A/UG, 3 clips) for a tight, vibration free fit. If the front panel does not detent on the distributor-transmitter base, bend the sides of the panel slightly as required.

c. FINAL TEST. — After all adjustments have been made and the equipment is assembled (paragraph 6-3), apply operating tests indicated in Section 2, paragraph 2-7.

6-5. WIRING DIAGRAMS.

Figures 6-35 through 6-37 are distributor-transmitter wiring diagrams. Winding data for components of the system is contained in table 6-1.

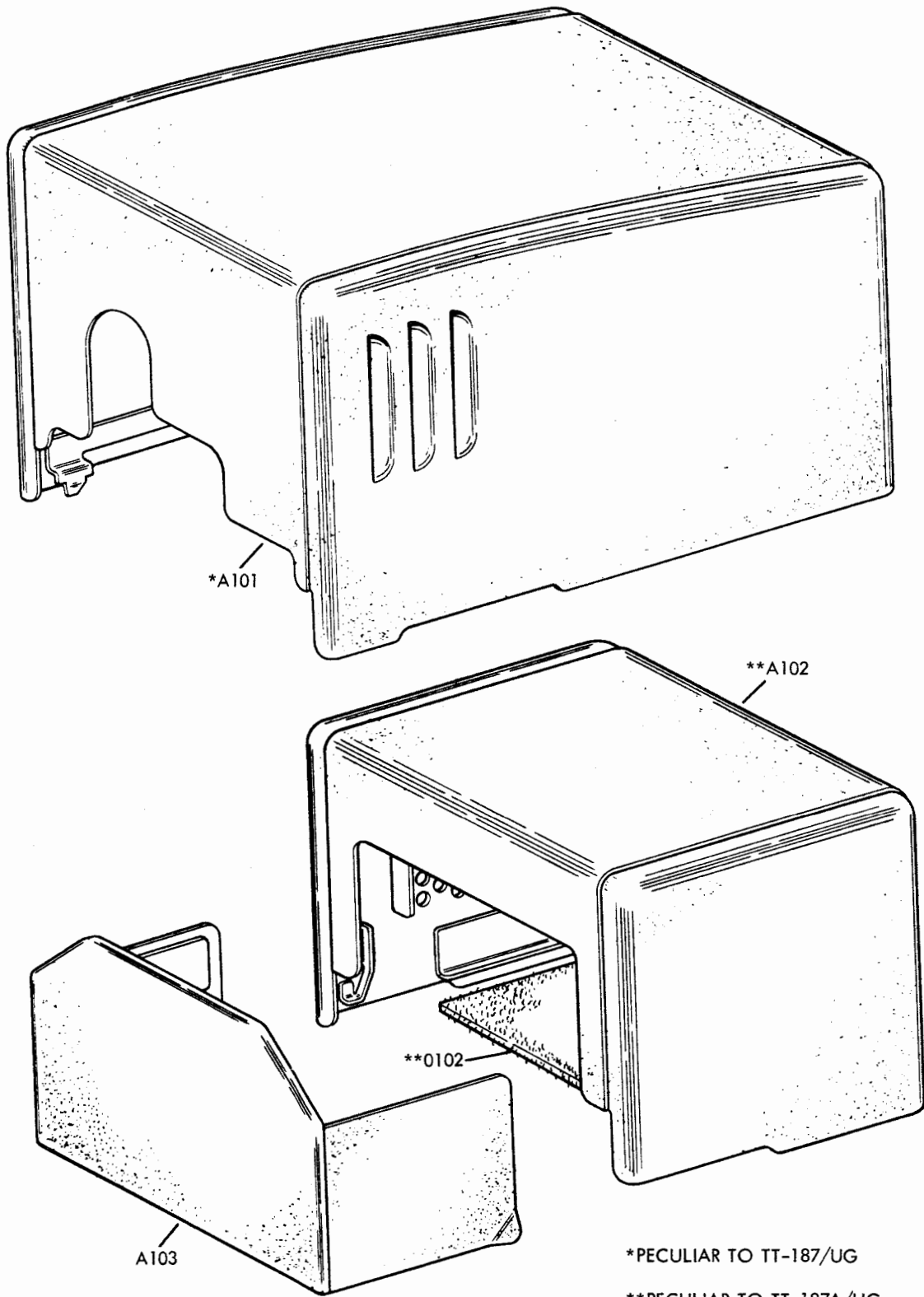

Figure 6-1. Covers

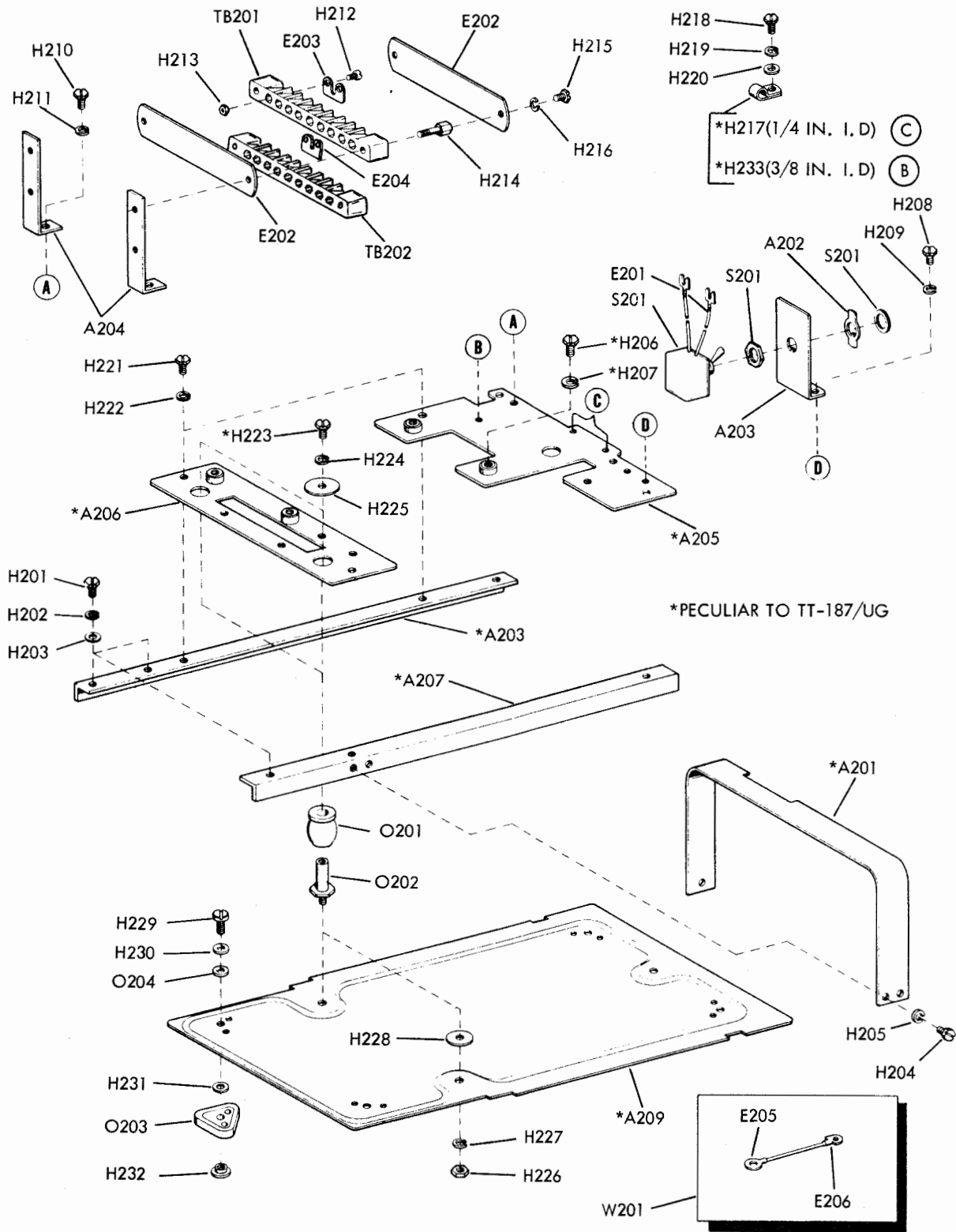

Figure 6-2. Base Assemblies

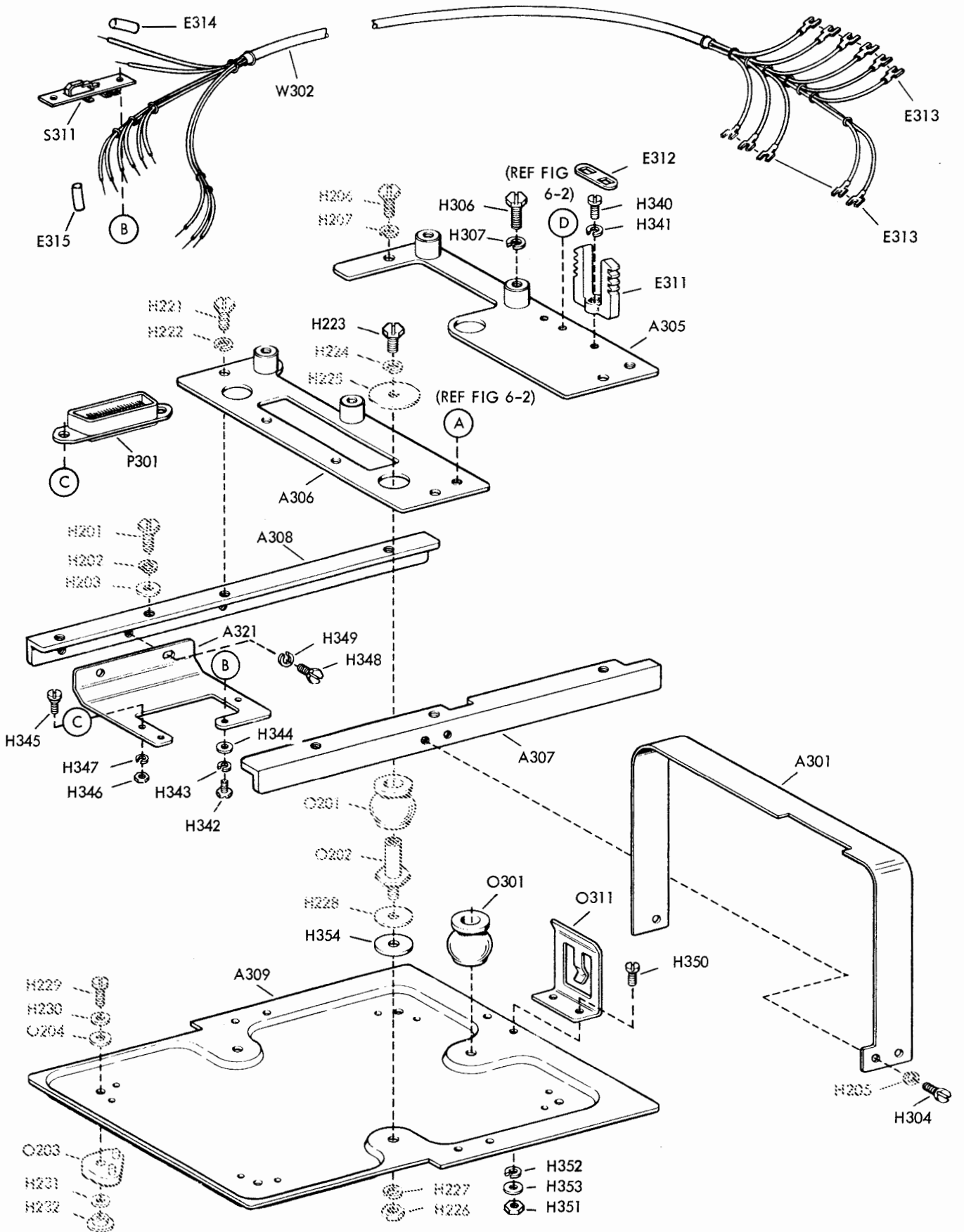
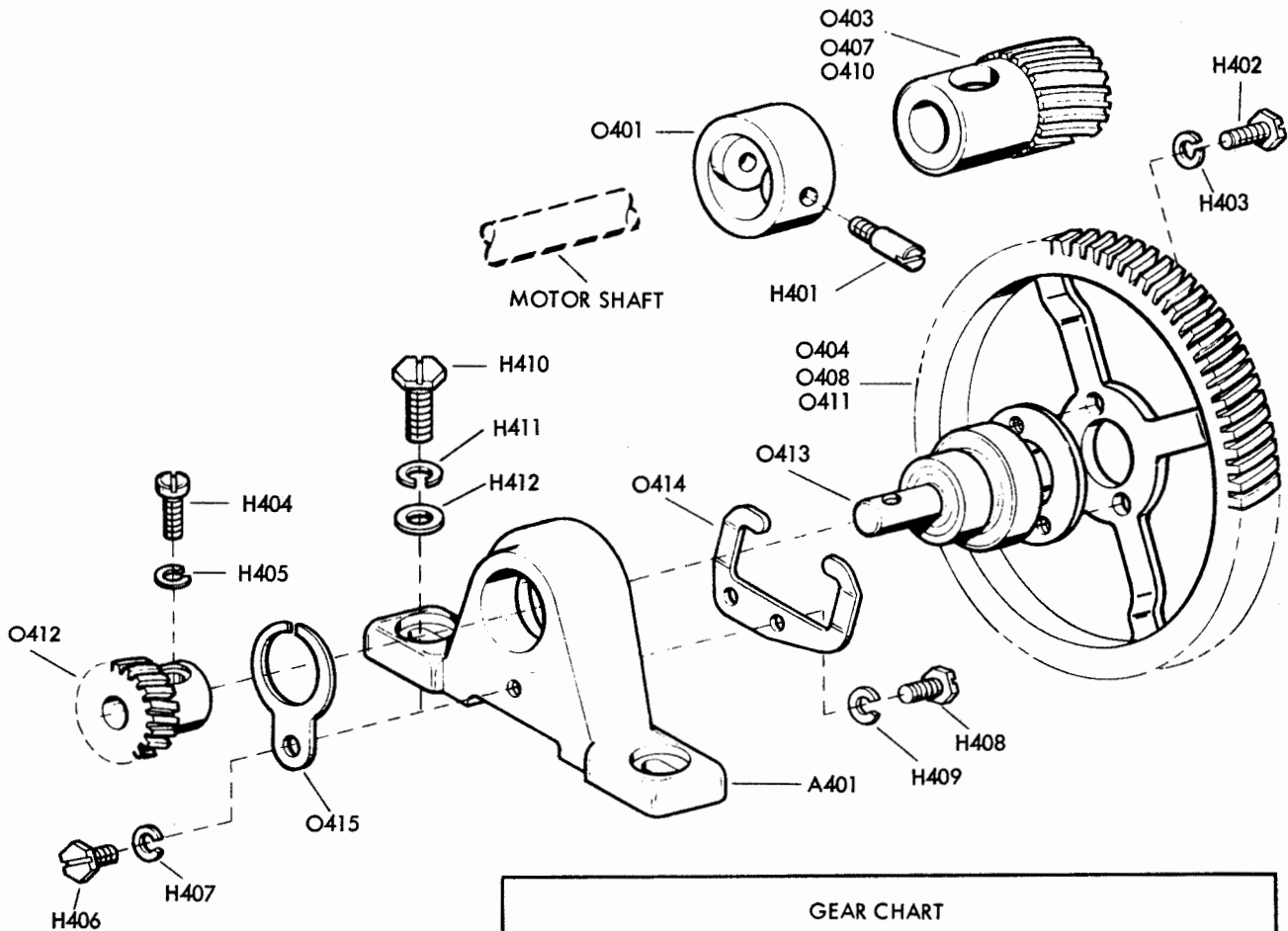

Figure 6-3. Miniaturized Base Assembly, TT-187A/UG



GEAR CHART				
SPEED	GEAR SET	PINION	DRIVEN GEAR	BAUD
60 WPM	A405	A403	A404	45.45
75 WPM	A406	A407	A408	56.9
100 WPM	A409	A410	A411	74.2

SEE T-1 FOR REFERENCE TO TORQUE W-2

Figure 6-4. Intermediate Gear Mechanism

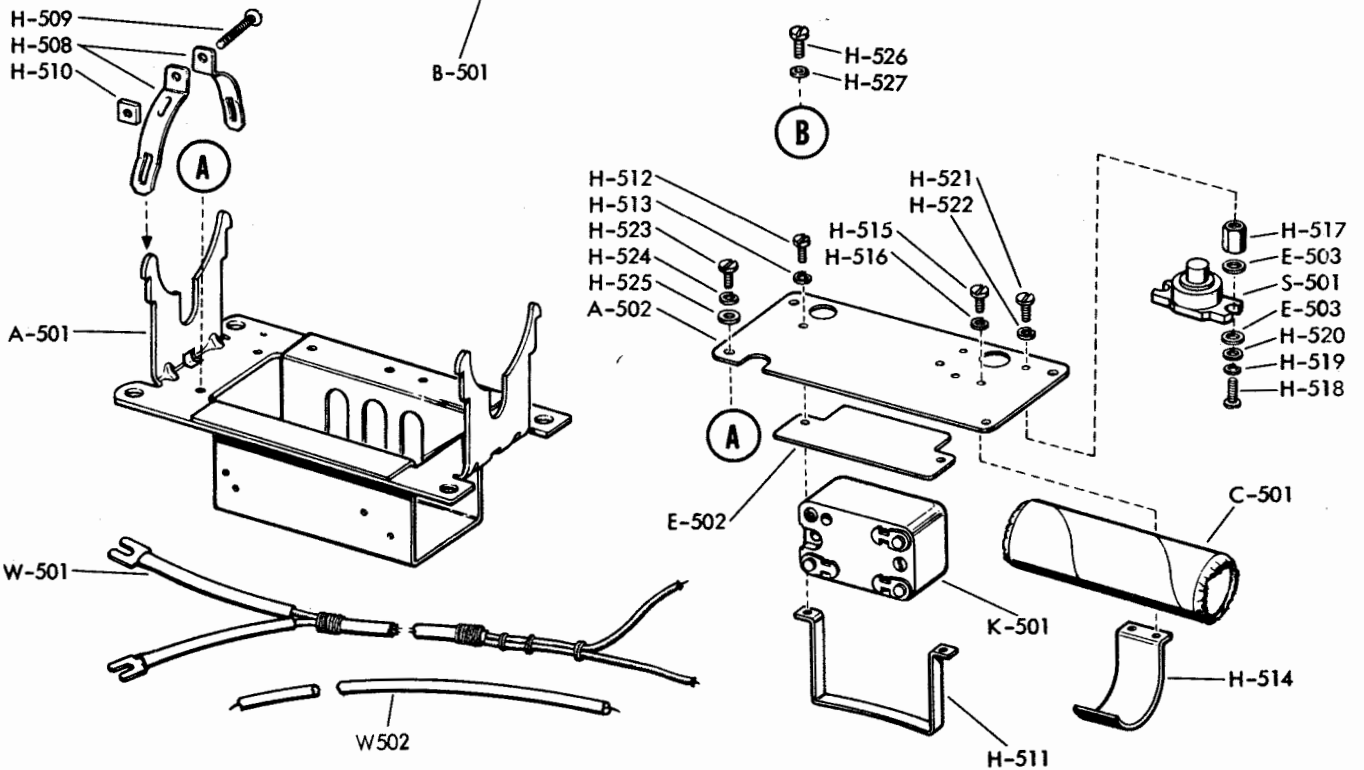
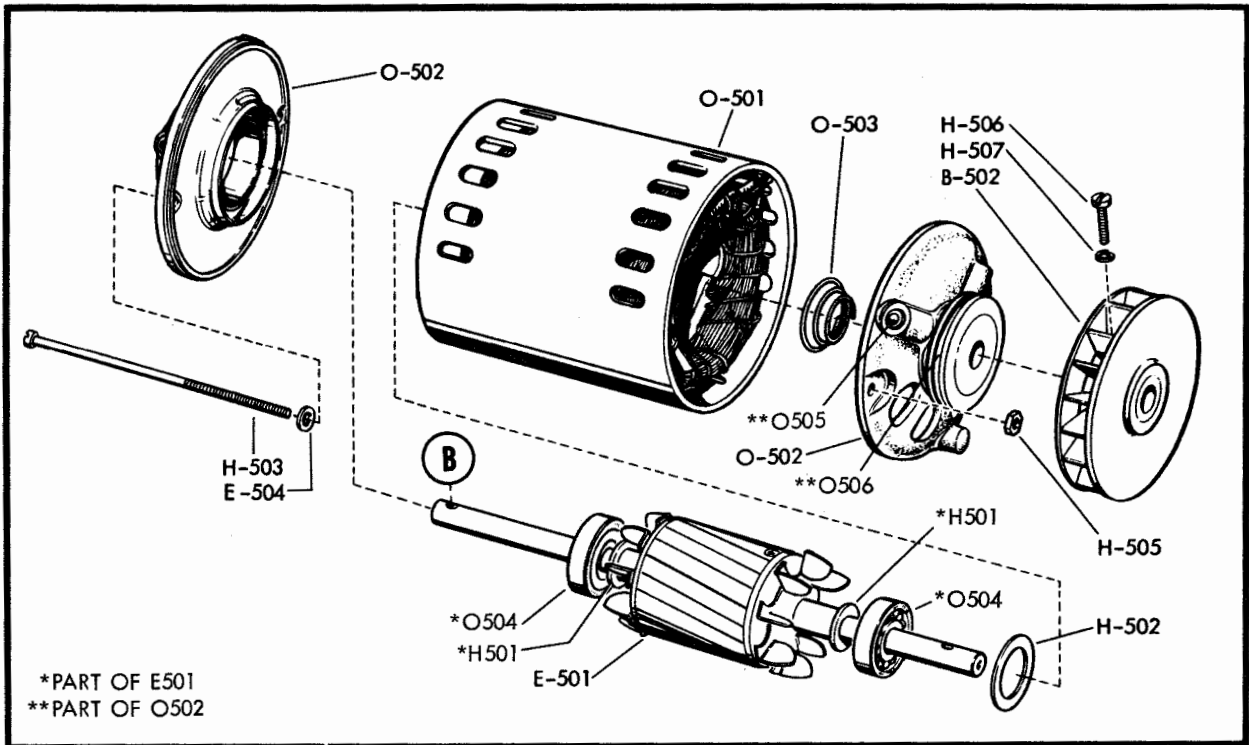

Figure 6-5. A. C. Synchronous Motor, TT-187/UG

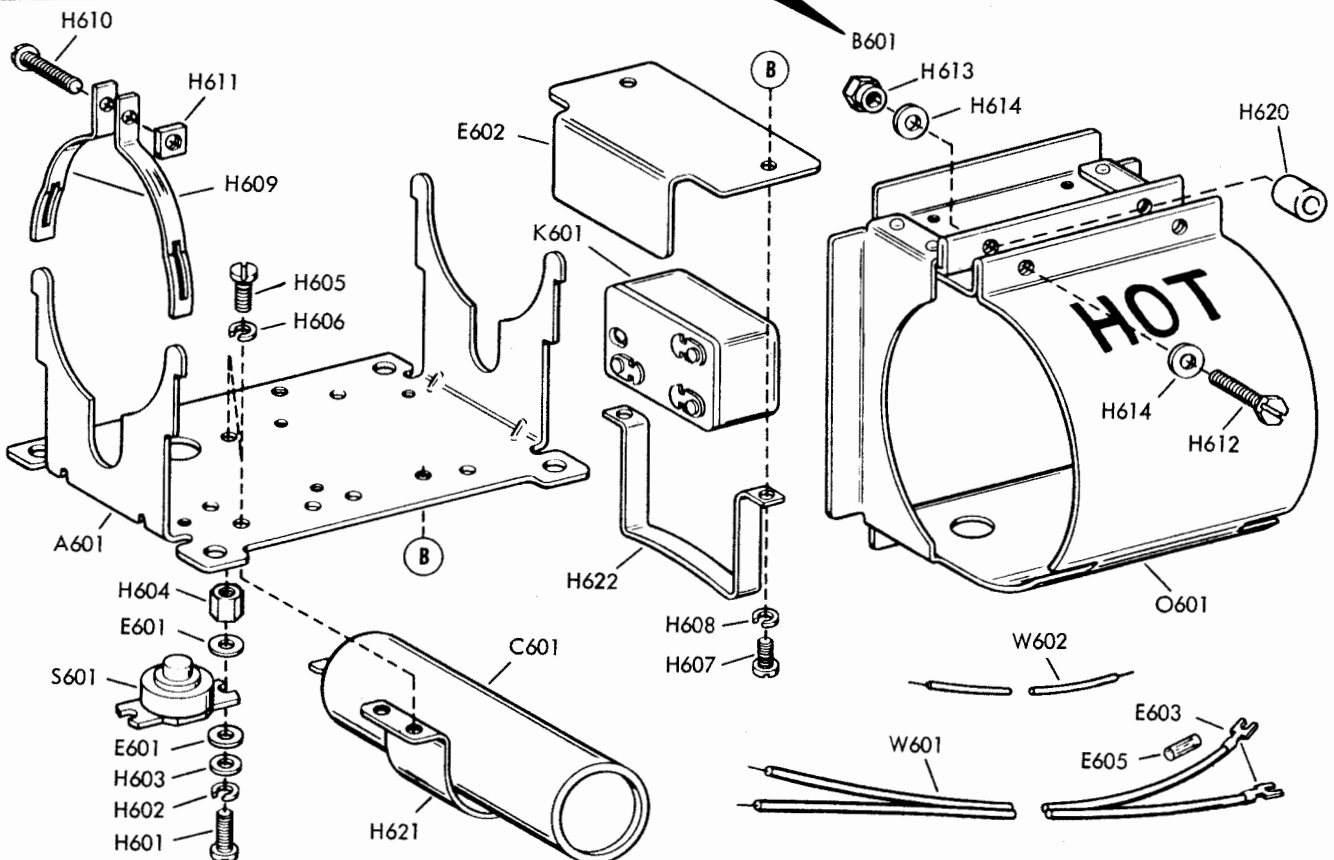
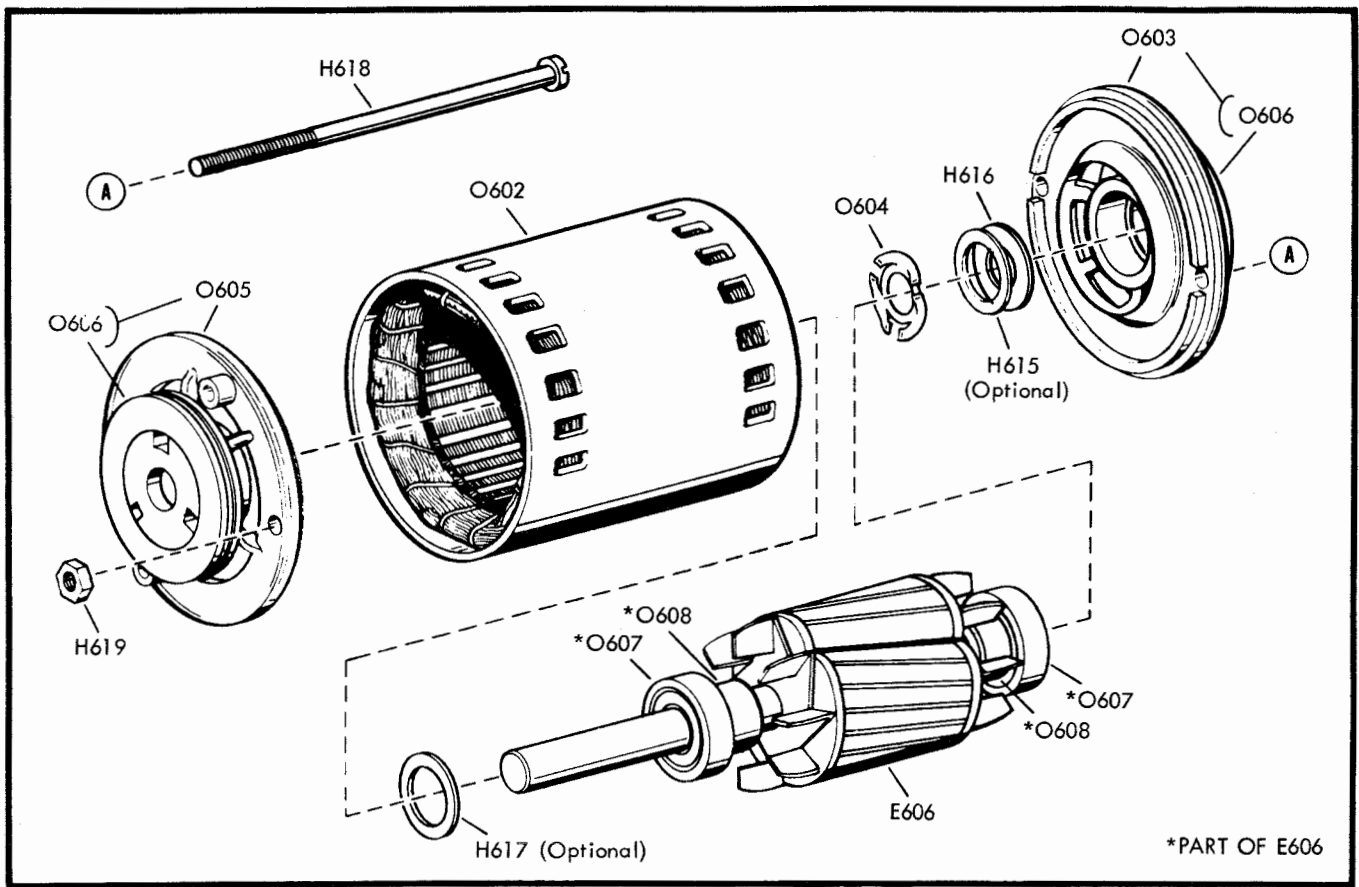

Figure 6-6. Miniaturized A.C. Synchronous Motor, TT-187/UG

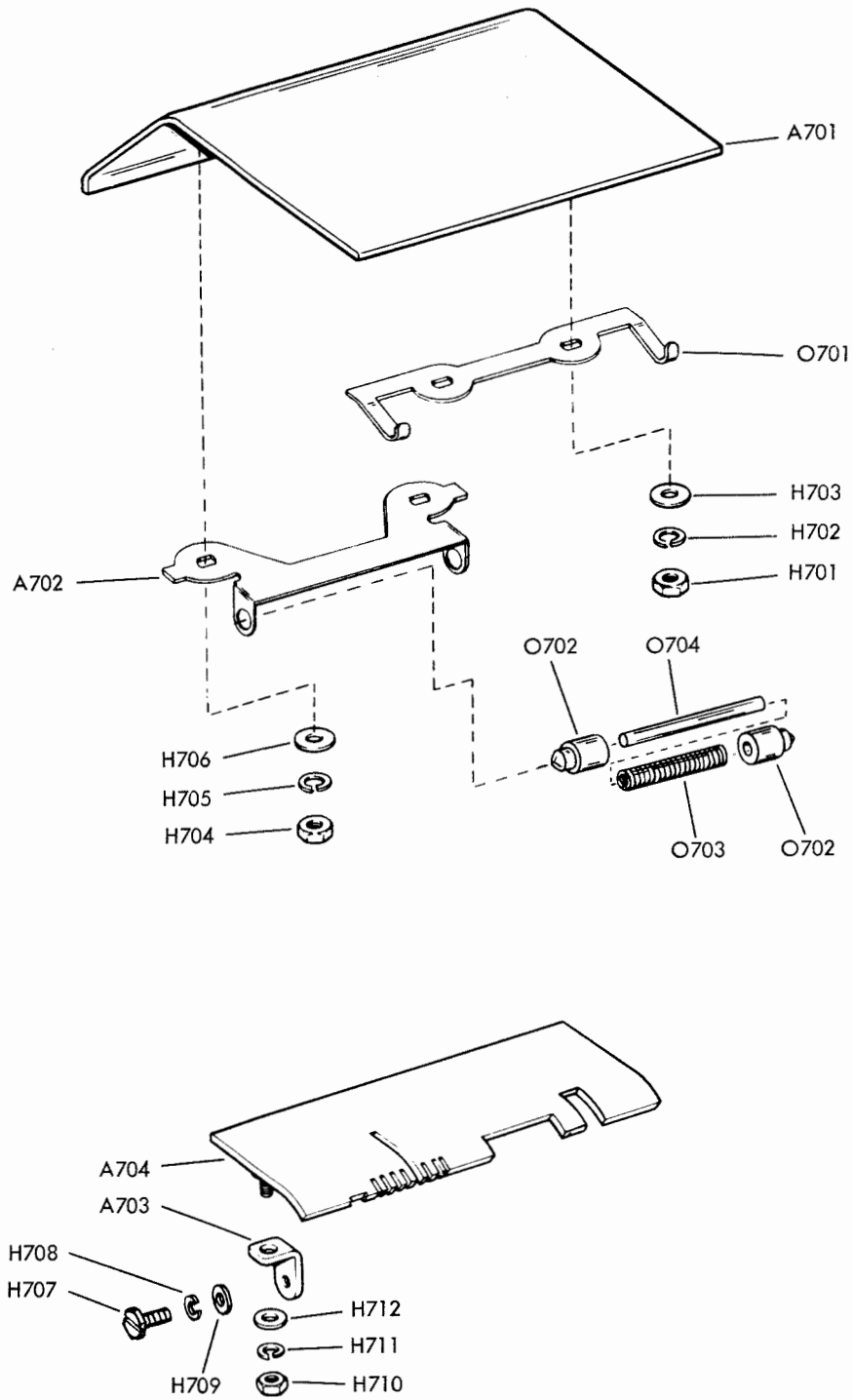

Figure 6-7. Distributor-Transmitter, Top and Cover Plates

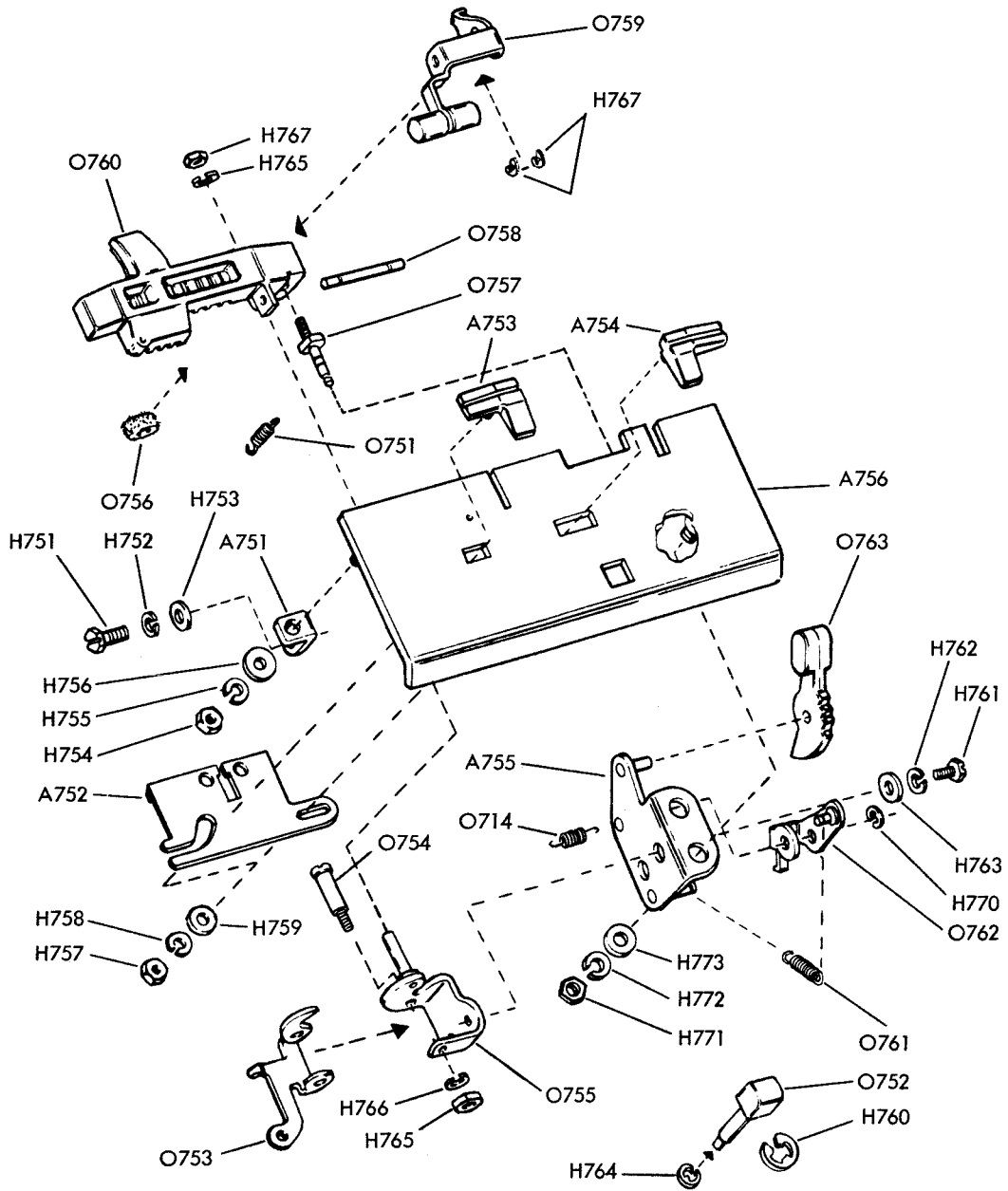

Figure 6-8. Distributor-Transmitter, Tape Guide Plate

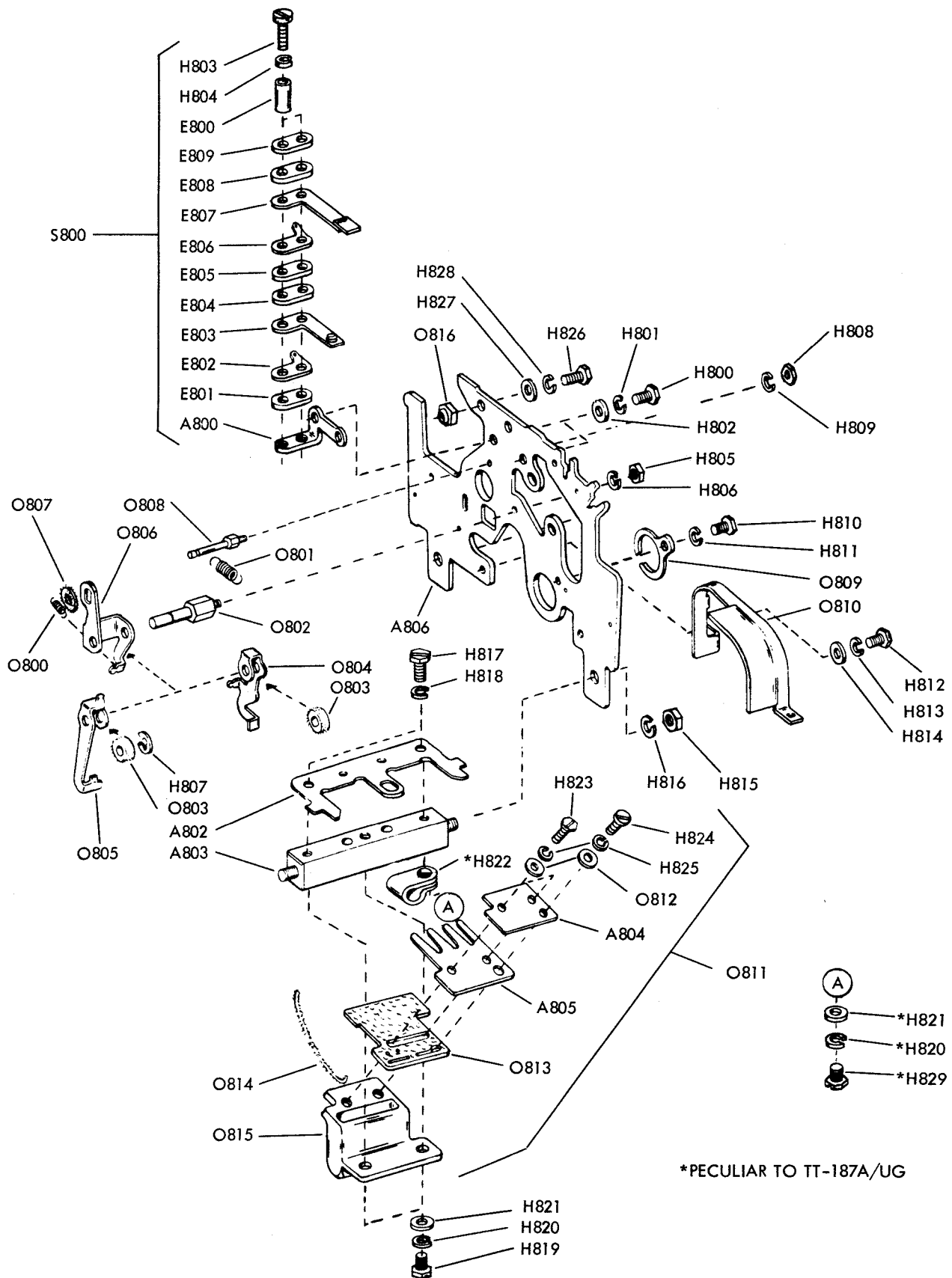

Figure 6-9. Distributor-Transmitter, Rear Plate Mechanism

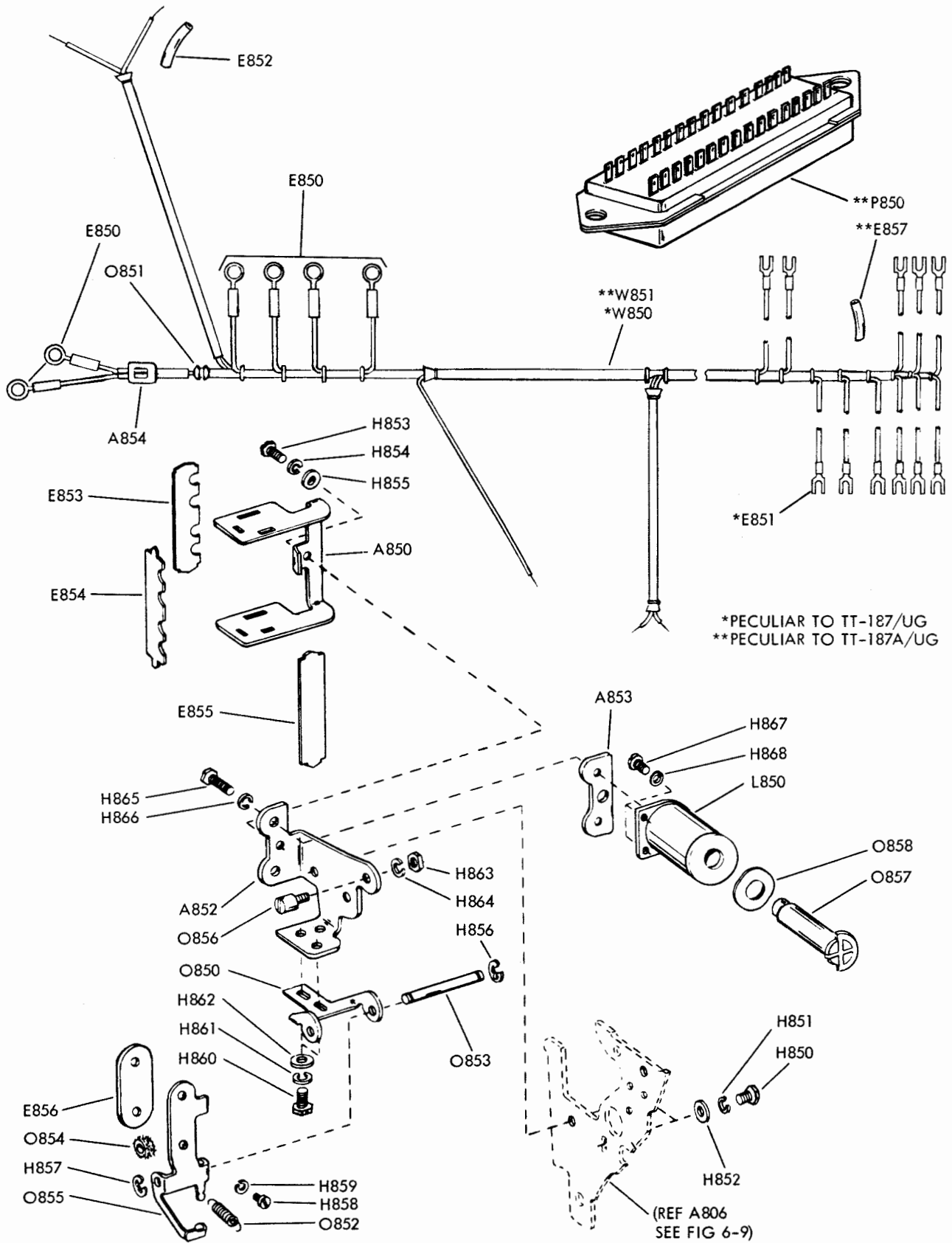

Figure 6-10. Distributor-Transmitter, Clutch Trip Magnet

SEE Change T-1 FOR REF TO THE
Following L 850 (LXD1, LXD4) TELETYPE
NO. 262M

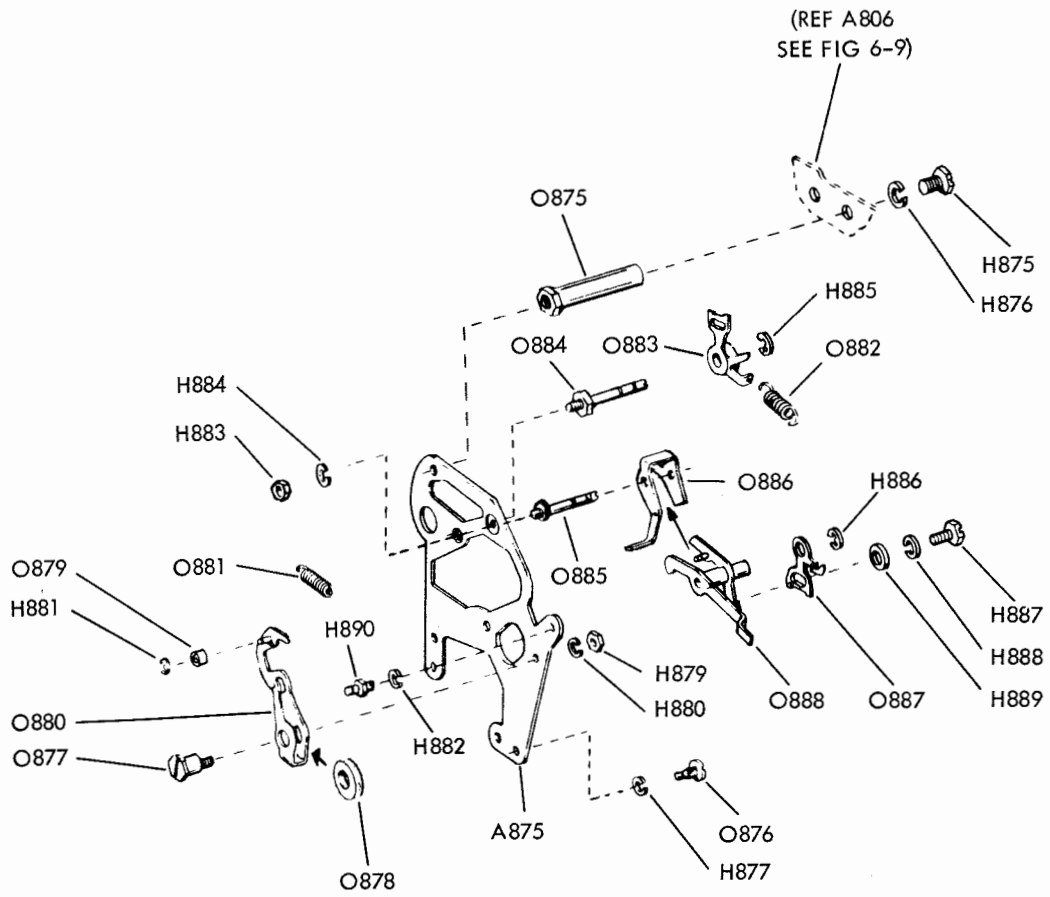

Figure 6-11. Distributor-Transmitter, Center Plate Mechanism

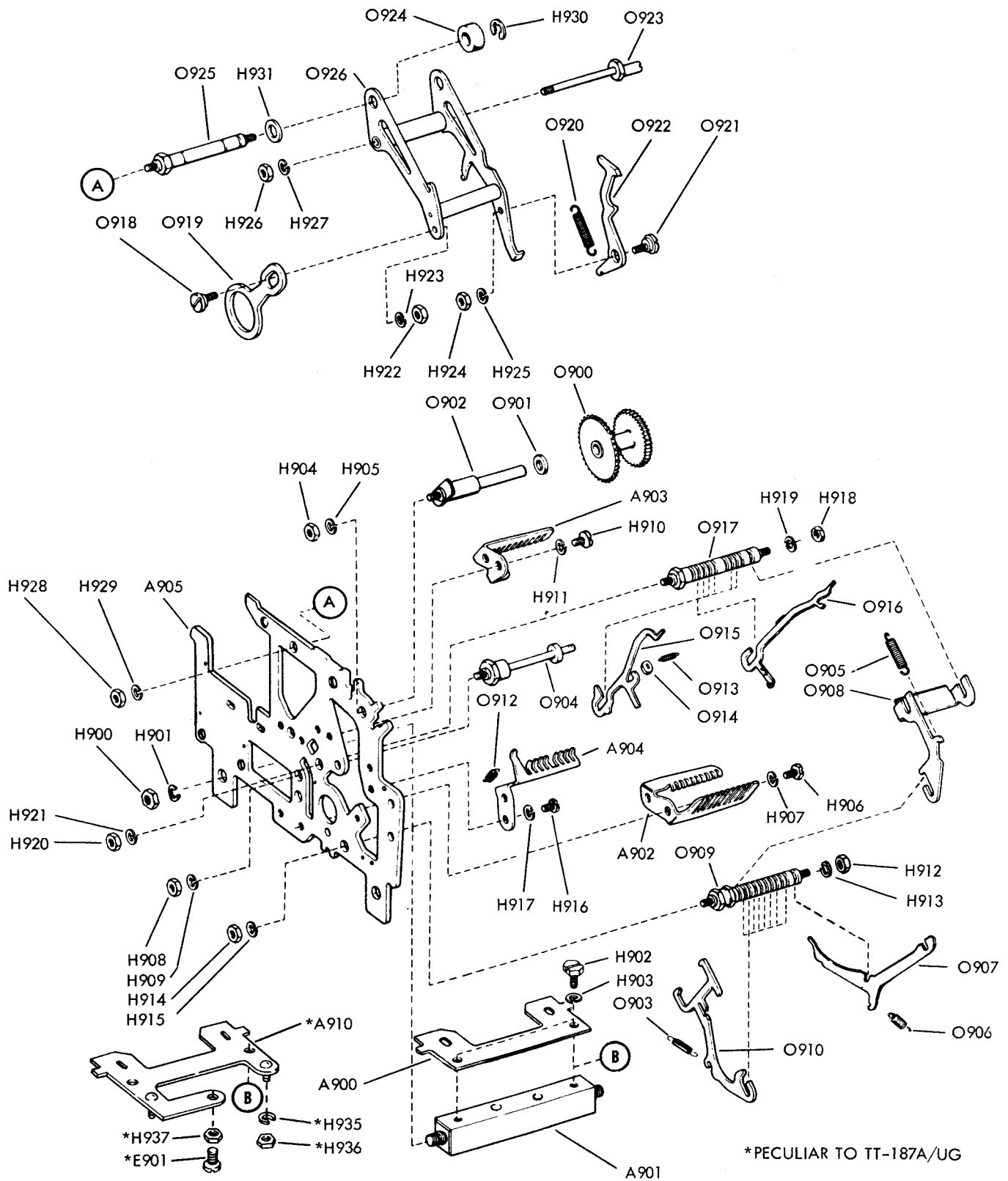

Figure 6-12. Distributor-Transmitter, Front Plate Mechanism

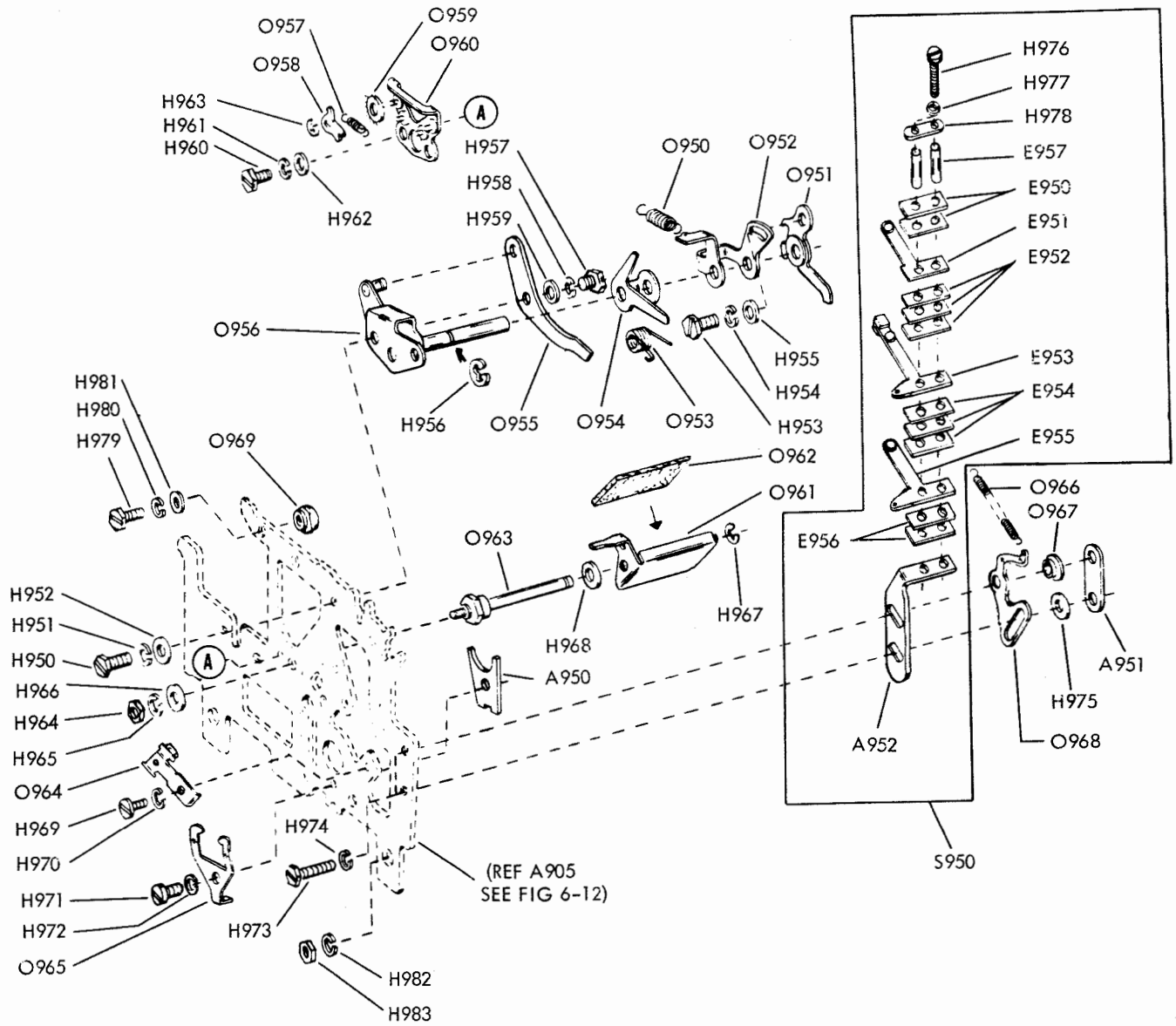

Figure 6-13. Distributor-Transmitter, Front Plate Mechanism

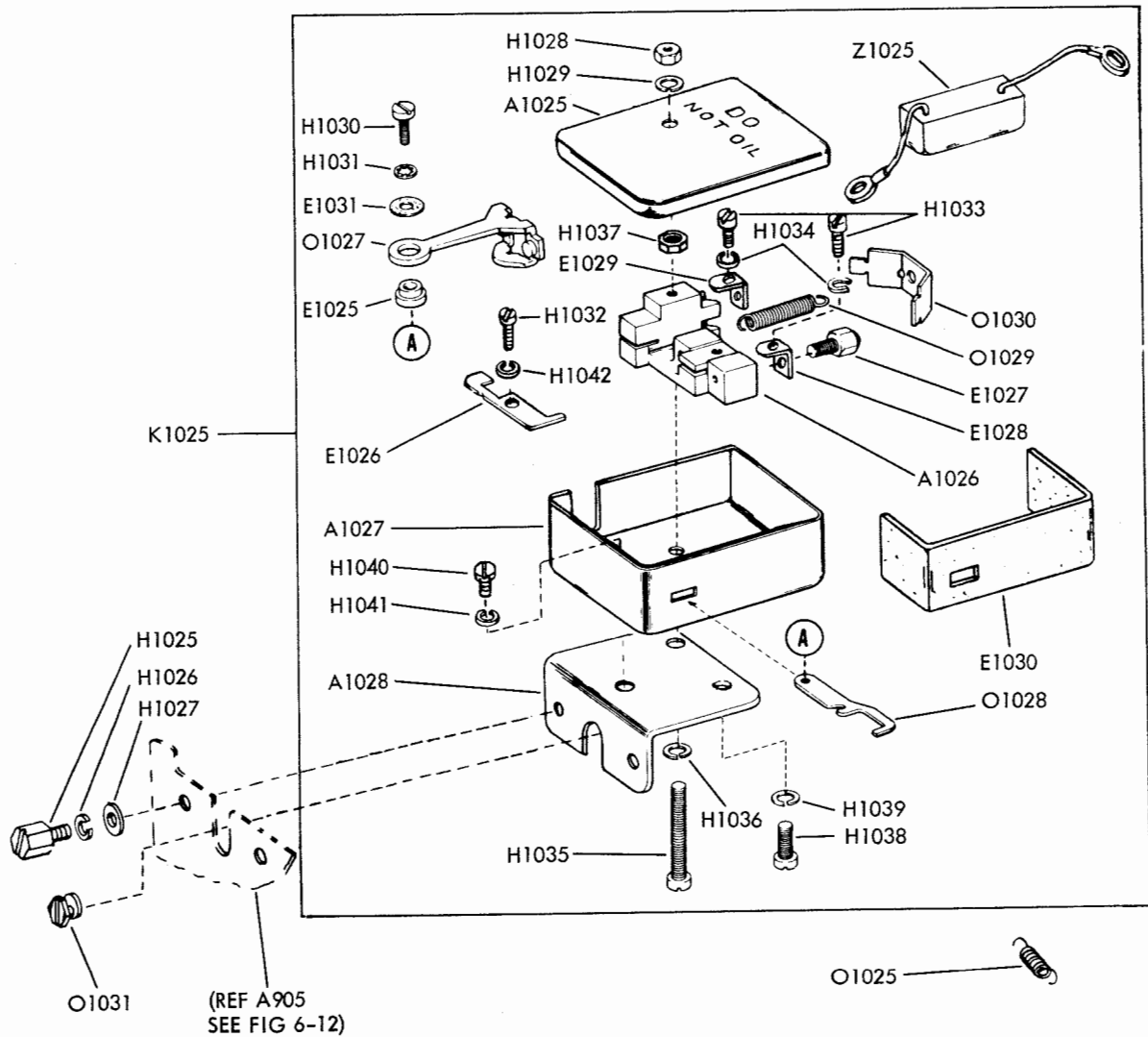

Figure 6-15. Distributor-Transmitter, Contact Box Assembly

APPLIES TO LXD1, LXD4. FOR LXD-11 SEE FIG-
6-14A IN T-1 "SEE T-1" FOR REF.
TO FIG 6-16, 6-17.

- (A) REMOVING FRONT PANEL
PULL OUTWARD ON LOWER RIGHT AND LEFT REAR CORNER OF FRONT PANEL AND SLIDE PANEL TOWARD THE FRONT. REPLACE IN REVERSE ORDER.
- (B) REMOVING COVER PLATE
LIFT END OF COVER PLATE TO DISENGAGE DETENTS. THEN SLIDE PLATE TOWARD THE LEFT TO DISENGAGE SPRING PLATE. REPLACE IN REVERSE ORDER.
- (C) REMOVING TOP PLATE
WITH FRONT AND REAR MOUNTING SCREWS LOOSENED (DO NOT DISTURB MOUNTING NUTS) AND TAPE LID RAISED, LIFT PLATE UPWARD. REFER TO FIGURE 6-19 WHEN REPLACING PLATE.
- (D) REMOVING TAPE GUIDE PLATE
WITH FRONT AND REAR MOUNTING SCREWS LOOSENED (DO NOT DISTURB MOUNTING NUTS) AND TAPE LID RAISED, LIFT PLATE UPWARD. REFER TO FIGURE 6-21 WHEN REPLACING PLATE.
- (E) REMOVING DISTRIBUTOR-TRANSMITTER
REMOVE RIGHT AND LEFT MOUNTING SCREWS ATTACHED TO BASE AND LIFT ASSEMBLY UPWARD TO DISENGAGE MAIN SHAFT GEAR. (TT-187/UG) - A GENEROUS LENGTH OF CABLE IS SUPPLIED TO FACILITATE INSPECTION OF THE UNIT WITHOUT DISCONNECTING LEADS. **CAUTION:** IN REPLACING ASSEMBLY, ROUTE CABLE AWAY FROM MOVING PARTS. (TT-187A/UG) - TRANSMITTER IS EQUIPPED WITH CONNECTOR IN BASE. AFTER UNIT IS PLUGGED IN, INSERT MOUNTING SCREWS. CHECK ALIGNMENT OF MAIN SHAFT GEAR WITH DRIVING GEAR (FIGURE 6-33). CHECK LINE SHUNT SWITCH ADJUSTMENT (FIGURE 6-34).

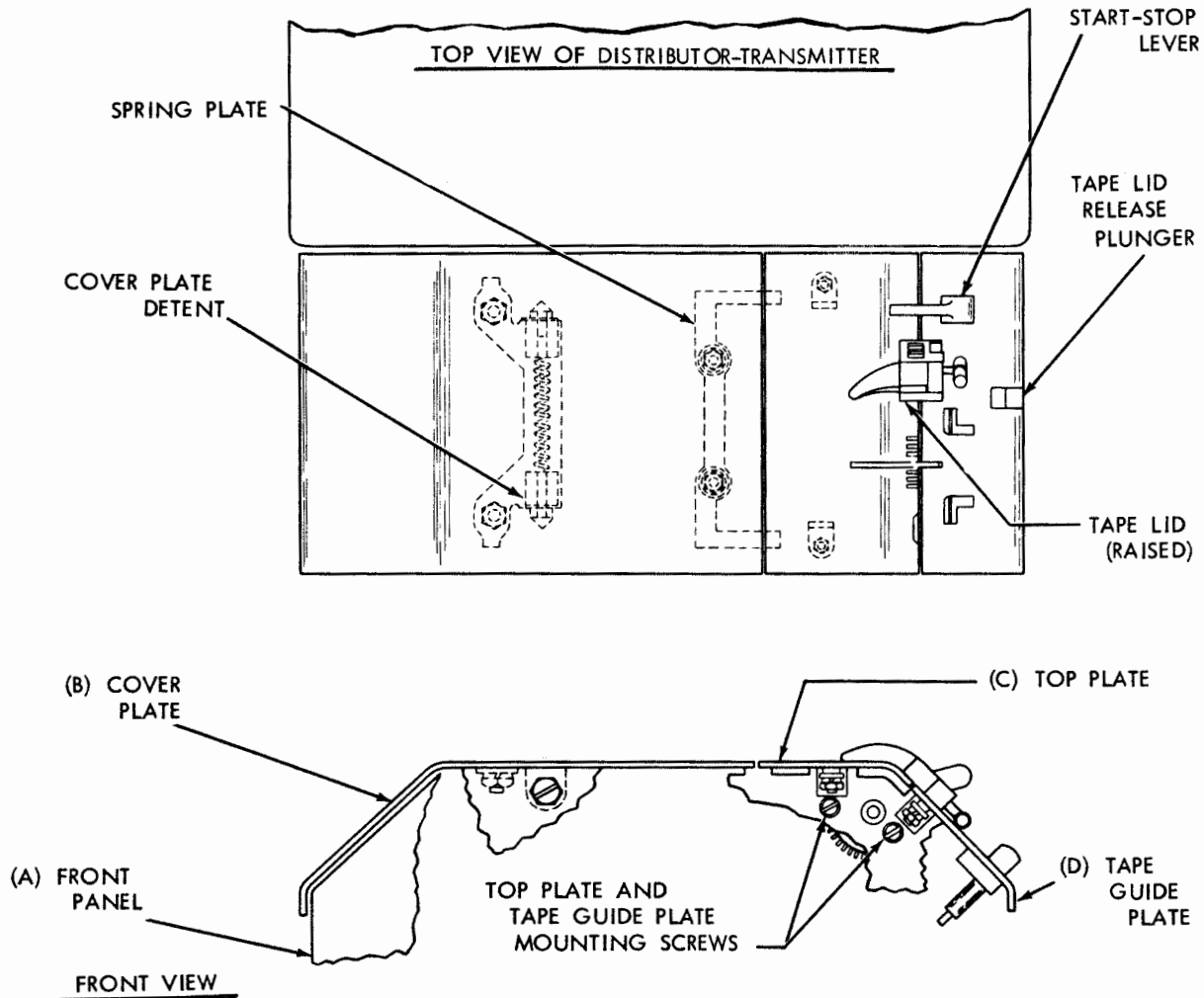
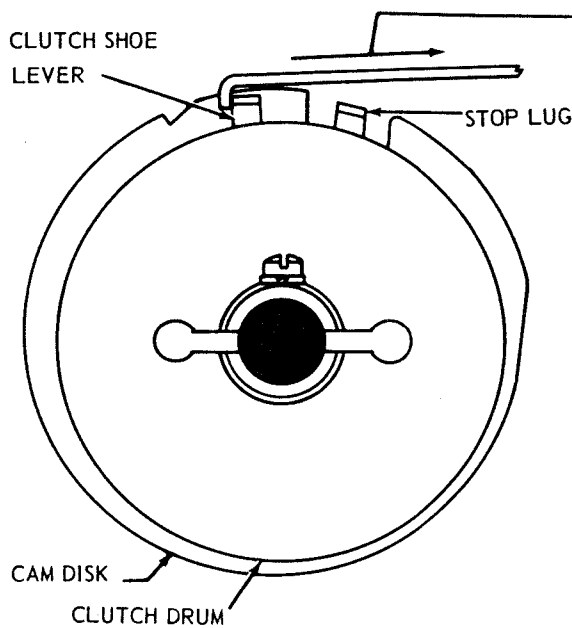

Figure 6-16. Cover Assemblies

617A

*Change
7-1*



CLUTCH SHOE LEVER SPRING TENSIONS
REQUIREMENT

CLUTCH ENGAGED. HOLD CAM DISK TO PREVENT TURNING. SPRING SCALE PULLED AT TANGENT TO CLUTCH.
MIN. 15 OZS.
MAX. 20 OZS.
TO MOVE THE SHOE LEVER IN CONTACT WITH THE STOP LUG.

NOTE 1

REQUIREMENTS ARE ADJUSTED AT THE FACTORY AND SHOULD NOT BE DISTURBED UNLESS ASSOCIATED MECHANISMS HAVE BEEN REMOVED FOR SERVICING OR THERE IS REASON TO BELIEVE THAT THE REQUIREMENTS ARE NOT MET.

NOTE 2

REMOVE MECHANISM FROM BASE PRIOR TO ADJUSTMENT (SEE FIGURE 6-14(E)). INVERT UNIT AND ROTATE MAIN SHAFT UNTIL CLUTCH SHOE LEVER AND STOP LUG ARE UP.

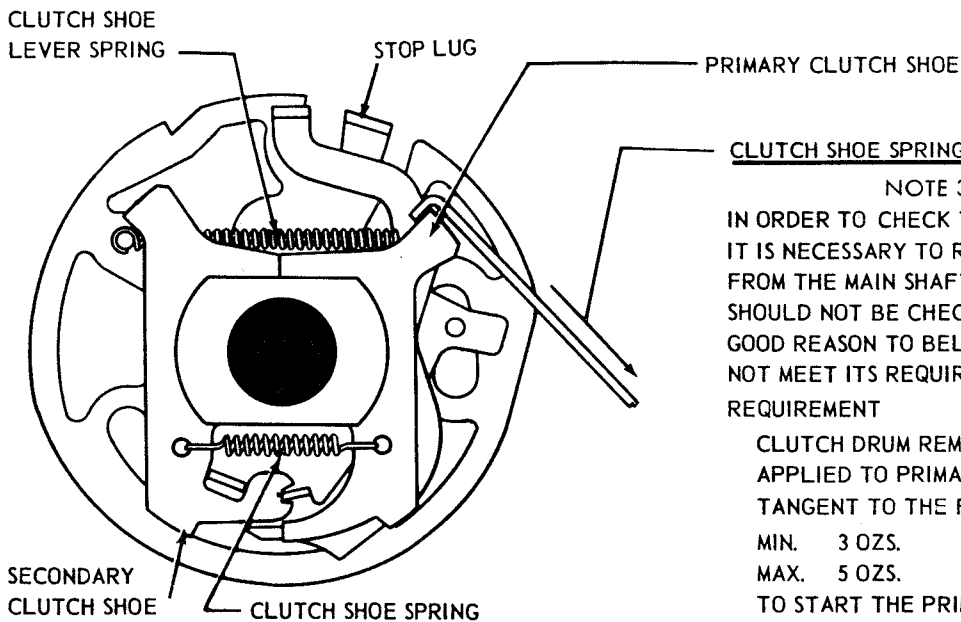

CLUTCH SHOE SPRING TENSION

NOTE 3

IN ORDER TO CHECK THIS SPRING TENSION, IT IS NECESSARY TO REMOVE THE CLUTCH FROM THE MAIN SHAFT. THEREFORE, IT SHOULD NOT BE CHECKED UNLESS THERE IS GOOD REASON TO BELIEVE THAT IT DOES NOT MEET ITS REQUIREMENT.

REQUIREMENT

CLUTCH DRUM REMOVED. SPRING SCALE APPLIED TO PRIMARY SHOE AT A TANGENT TO THE FRICTION SURFACE.
MIN. 3 OZS.
MAX. 5 OZS.
TO START THE PRIMARY SHOE MOVING AWAY FROM SECONDARY SHOE AT POINT OF CONTACT.

Figure 6-17. Clutch Mechanism

6-17B

ORIGINAL

*Change
7-1*

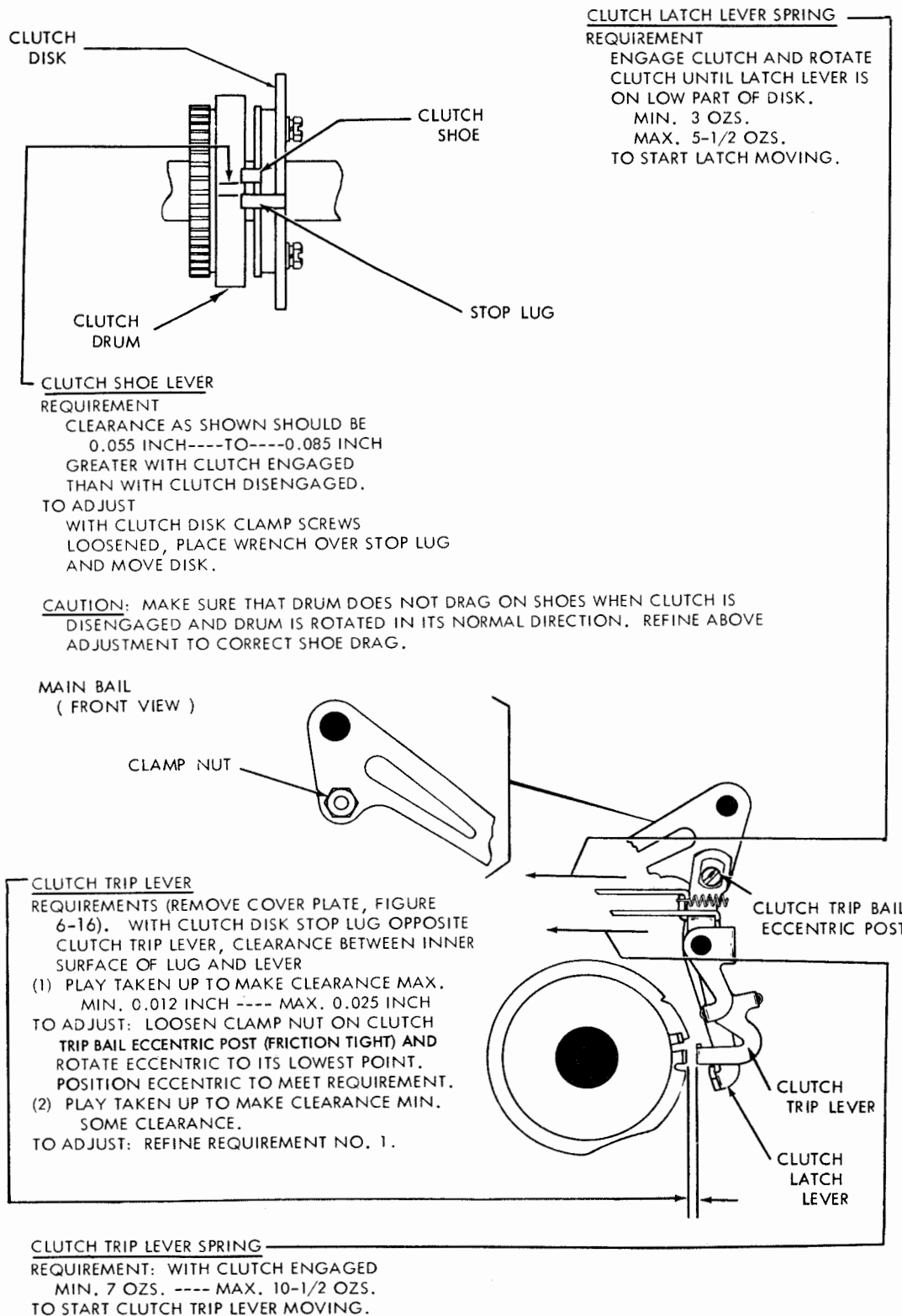

Figure 6-18. Clutch Trip Mechanism

TAPE LID

REQUIREMENTS----(REMOVE TOP AND TAPE GUIDE PLATES. LUBRICATE PRIOR TO ADJUSTMENT.)

- (1) WITH TAPE LID HELD AGAINST NOTCH IN TAPE GUIDE PLATE
 - A FEED WHEEL IN GROOVE IN TAPE LID SHOULD ALIGN WITH SLOT IN PLATE.
 - B HOLE IN TAPE LID FOR TAPE-OUT PIN SHOULD ALIGN WITH HOLE IN PLATE. (GAUGE BY EYE.)
 - C CLEARANCE BETWEEN PIVOT SHOULDER AND TAPE LID SOME _____ TO _____ 0.010 INCH MAX.

TO ADJUST

WITH TAPE LID BRACKET MOUNTING NUTS (2) LOOSENED (INSERT TIP OF 156743 GAUGE THROUGH SLOT AND INTO GROOVE OF LID), POSITION TAPE LID BRACKET. RETIGHTEN NUTS.

- (2) TAPE LID FRONT BEARING SURFACE (A) SHOULD TOUCH TAPE GUIDE PLATE. CLEARANCE (B) MEASURED AT FIN OF TAPE LID WHICH IS IN LINE WITH REAR TAPE GUIDE (SEE NOTE 2)
 - MIN. 0.010 INCH----MAX. 0.018 INCH

NOTE 1: WHEN BOTH PLATES ARE ASSEMBLED ON UNIT, LEFT EDGE OF LID MAY TOUCH TOP PLATE AND SOME CHANGE IN THIS CLEARANCE MAY BE EXPECTED.

TO ADJUST

WITH TAPE LID BEARING BRACKET MOUNTING SCREWS FRICTION TIGHT AND TAPE LID PRESSED AGAINST TAPE GUIDE PLATE, POSITION BEARING BRACKET. RECHECK REQUIREMENT NO. 1.

SEE SPRING REQUIREMENTS, FIGURE 6-20

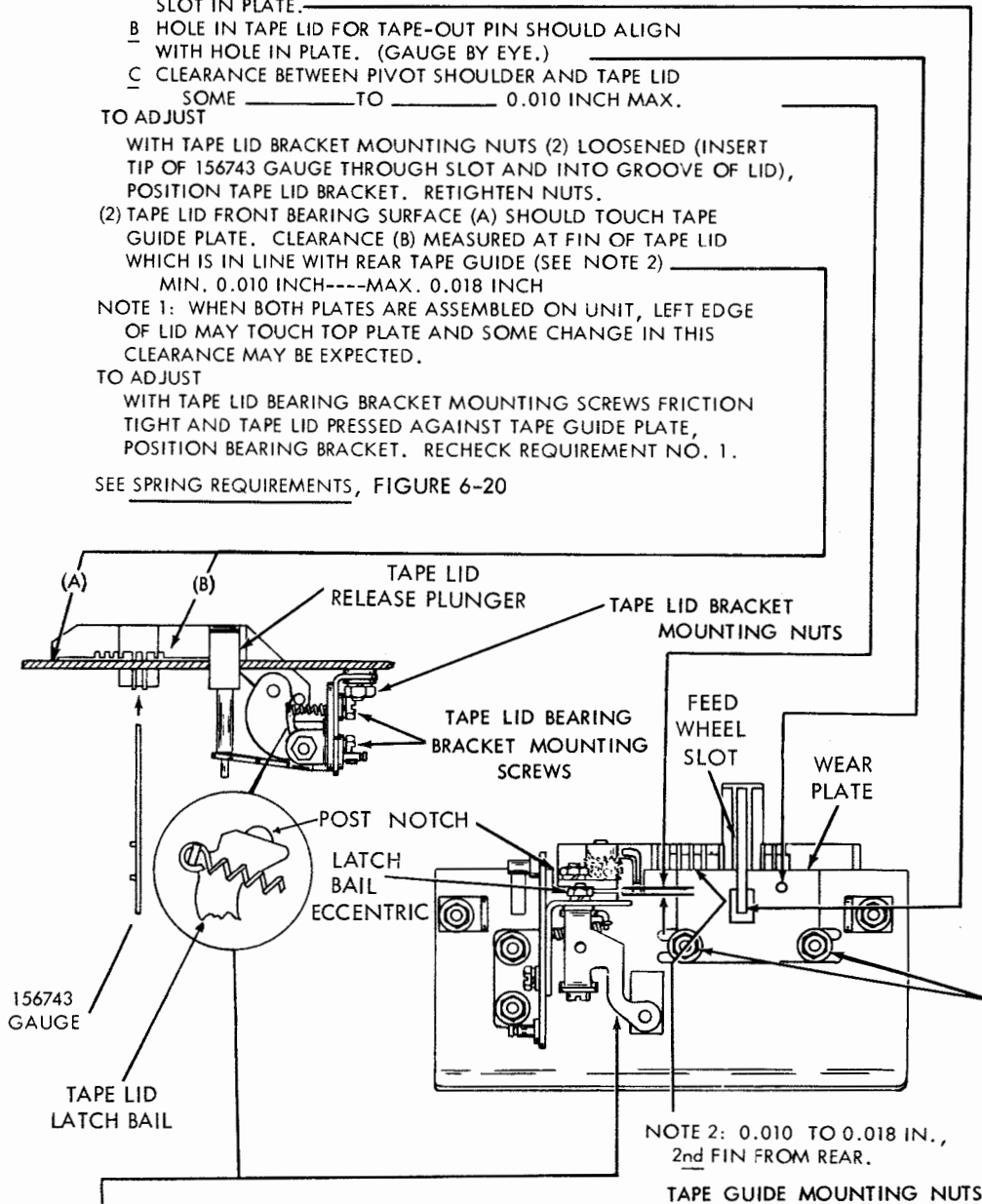

- (3) RELEASE PLUNGER SHOULD HAVE SOME END PLAY WHEN LID IS LATCHED AGAINST TAPE GUIDE PLATE.

TO ADJUST----WITH ECCENTRIC MOUNTING POST LOCK NUT FRICTION TIGHT AND TAPE LID RAISED, ROTATE HIGH PART OF ECCENTRIC TOWARD TAPE GUIDE PLATE. CLOSE LID AND ROTATE ECCENTRIC TOWARD BRACKET UNTIL LATCH JUST FALLS UNDER FLAT ON POST. RE-CHECK BY DEPRESSING PLUNGER --- WITH LID HELD DOWN, TIP OF LATCH SHOULD CLEAR POST AS PLUNGER IS OPERATED.

Figure 6-19. Tape Guide Plate

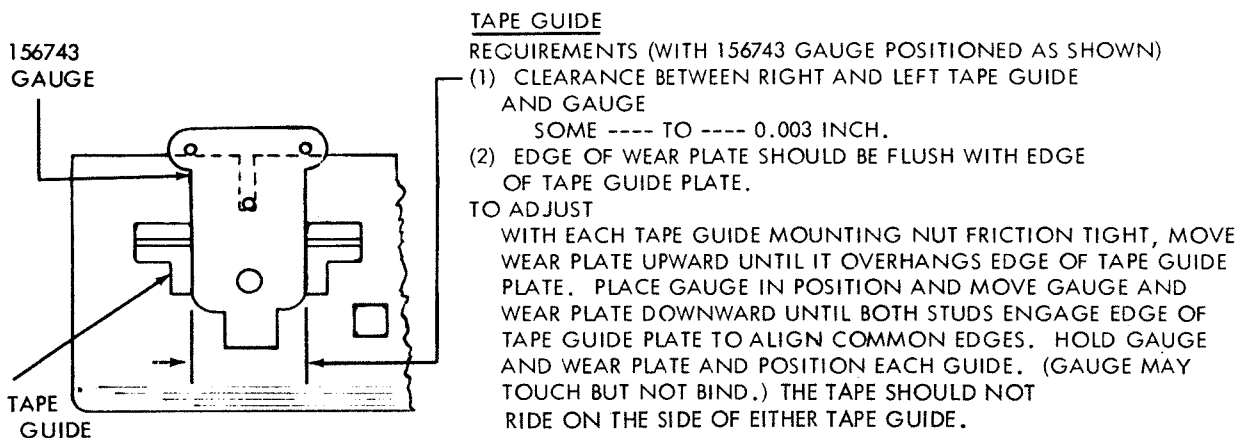
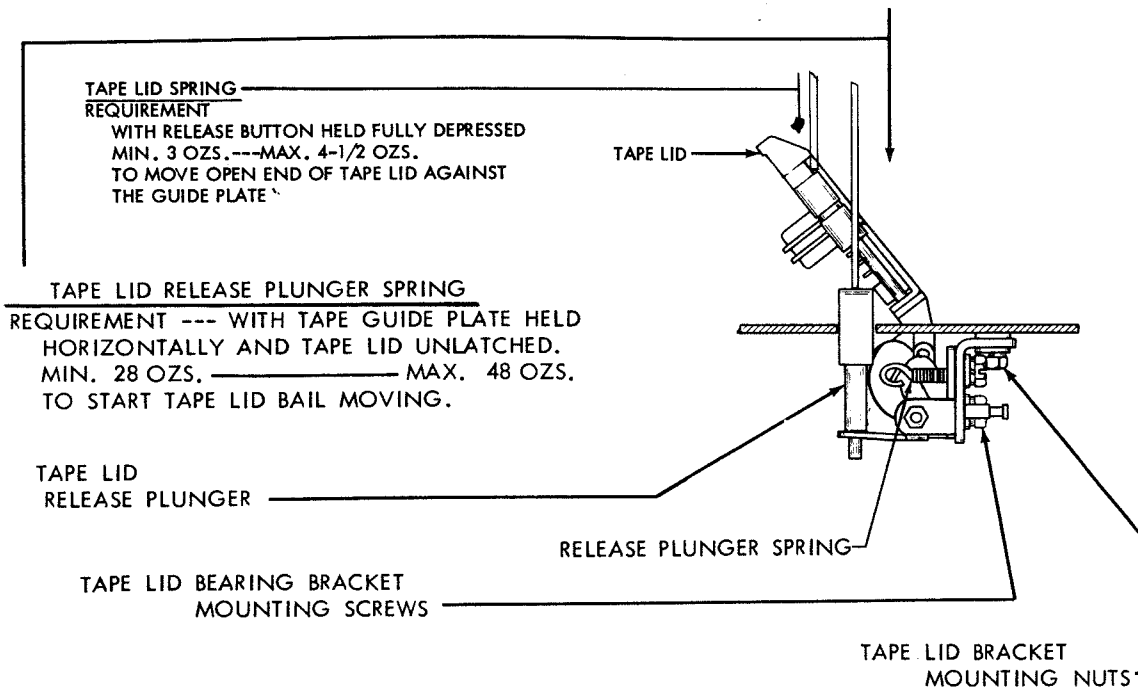
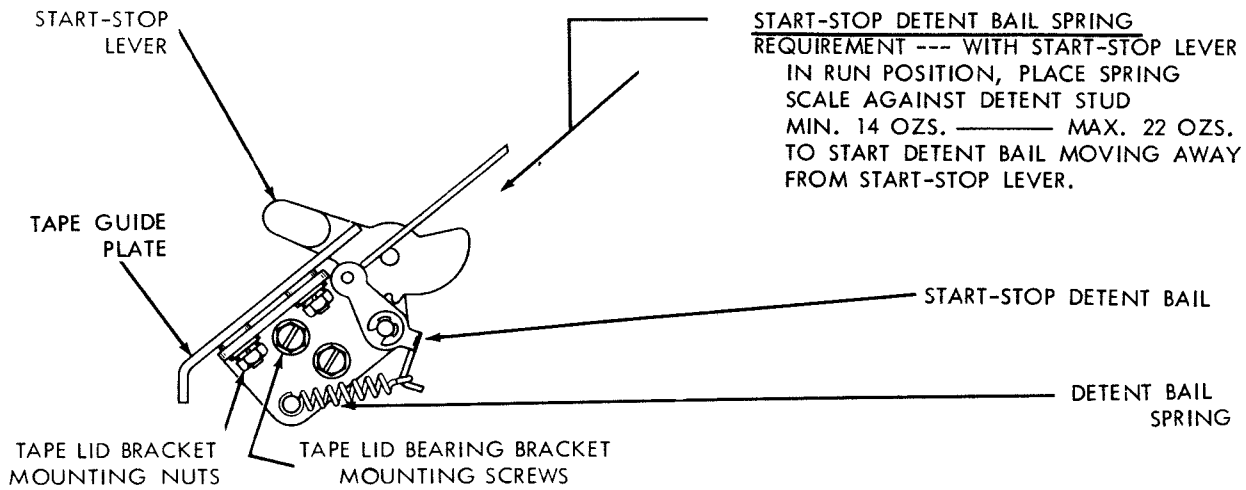
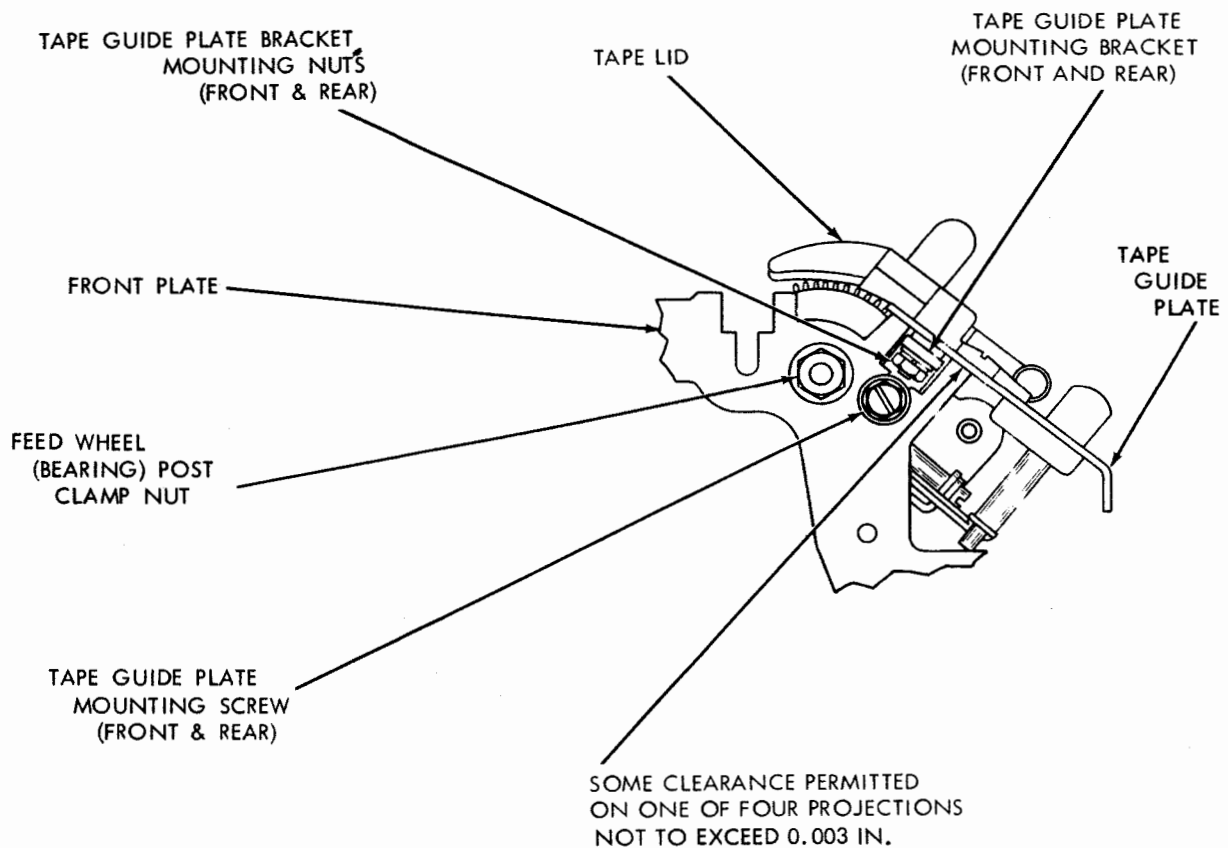

Figure 6-20. Tape Lid Assembly



REPLACING AND POSITIONING TAPE GUIDE PLATE REQUIREMENTS

- (1) SHOULDER OF FEED WHEEL POST SHOULD NOT INTERFERE WITH TOP PLATE OR TAPE GUIDE PLATE MOUNTING BRACKETS.
TO ADJUST (SEE NOTE 1)
WITH FEED WHEEL BEARING POST CLAMP NUT FRICTION TIGHT, POSITION THE POST.
- (2) TAPE GUIDE SHOULD REST FIRMLY AGAINST AT LEAST THREE PROJECTIONS OF FRONT AND REAR PLATE.
TO ADJUST (SEE NOTE 1)
WITH CLAMP NUT THAT SECURES TAPE GUIDE PLATE MOUNTING BRACKET (FRONT AND REAR) FRICTION TIGHT, TRIP CLUTCH AND ROTATE SHAFT UNTIL SENSING PINS ARE IN THEIR UPPERMOST POSITION. WITH TAPE LID RAISED AND START-STOP LEVER IN RUN POSITION, PRESS GUIDE PLATE INTO POSITION WHILE GUIDING MOUNTING SCREWS INTO NOTCH OF FRONT AND REAR PLATE ENGAGE TIP OF TAPE-OUT PIN WITH HOLE IN TAPE GUIDE PLATE.
- (3) OUTER EDGES OF MOUNTING BRACKETS AND OUTER EDGES OF (MOUNTING STUD) SHOULDER SHOULD ALIGN OR BE POSITIONED EQUALLY AT FRONT AND REAR WITH RESPECT TO THE BRACKETS. (GAUGE BY EYE. SEE FIGURE 6-33.)
TO ADJUST
MOVE TAPE GUIDE PLATE TOWARD THE FRONT OR REAR. TIGHTEN NUTS ONLY AFTER TOP PLATE (FIGURE 6-22) IS ADJUSTED.

NOTE 1: POSITION TAPE-OUT SENSING PIN STOP ARM (SEE FIGURE 6-24) IN ITS LOWEST POSITION AND HOLD START-STOP BAIL EXTENSION FROM RATCHET WHEEL.

Figure 6-21. Tape Guide Plate Mounting

REPLACING AND POSITIONING TOP PLATE----LOOSEN NUTS (FRICTION TIGHT) THAT SECURE MOUNTING BRACKETS TO PLATE. PRESS TOP PLATE INTO POSITION WHILE GUIDING TOP PLATE MOUNTING SCREWS INTO NOTCH OF FRONT AND REAR PLATE. POSITION EACH SENSING PIN IN ITS SLOT. MAKE SURE THAT TOP PLATE SEATS FIRMLY AGAINST PROJECTIONS OF FRONT AND REAR PLATE (3 PROJECTIONS SHOULD ENGAGE) AND TIGHT TAPE ARM EXTENSION IS UNDER TOP PLATE.

REQUIREMENT

- (1) MATING EDGE OF TOP PLATE SHOULD BE FLUSH----TO----0.003 INCH UNDER FLUSH WITH EDGE OF TAPE GUIDE PLATE (WITHIN AREA OF TAPE LID) WHEN PLATE ENGAGES AT LEAST 3 PROJECTIONS.
 - (2) FEED WHEEL SHOULD ALIGN WITH SLOT IN TAPE GUIDE PLATE.
 - (3) CLEARANCE BETWEEN PROJECTION OF TAPE LID AND TOP PLATE (SEE NOTE 1),
MIN. 0.010 INCH ---- MAX. 0.020 INCH (PLAY TAKEN UP TOWARD TAPE GUIDE PLATE).
- TO ADJUST REQUIREMENT NUMBER ---
- (1) POSITION TOP PLATE AND TAPE GUIDE PLATE BY MEANS OF THEIR OVERSIZED MOUNTING HOLES. TIGHTEN MOUNTING SCREWS.
 - (2) POSITION PLATES SO THAT FEED WHEEL ROTATES FREELY WHEN ITS DETENT AND FEED PAWL ARE DISENGAGED. TIGHTEN NUTS THAT SECURE MOUNTING BRACKETS TO TOP PLATE AND TAPE GUIDE PLATE. (DO NOT DISTURB REQUIREMENT 2, FIGURE 6-21.)
 - (3) IF NECESSARY, LOOSEN TAPE LID BEARING BRACKET MOUNTING SCREWS AND POSITION TAPE LID. TIGHTEN SCREWS AND RECHECK REQUIREMENTS (1) and (2), FIGURE 6-19.

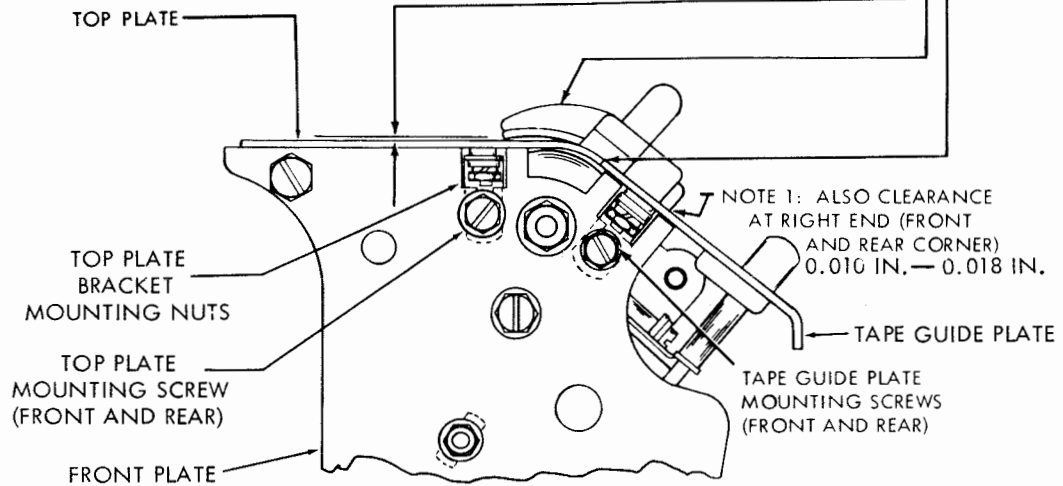

REPLACING AND POSITIONING COVER PLATE

REQUIREMENT----

1. RIGHT EDGE OF COVER PLATE SHOULD BE HELD FLUSH AGAINST LEFT EDGE OF TOP PLATE BY THE COVER PLATE DETENTS.
 2. COVER PLATE SHOULD REST AGAINST AT LEAST THREE OF THE FOUR PROJECTIONS (FRONT & REAR PLATE).
 3. FRONT EDGE OF COVER PLATE AND TOP PLATE SHOULD ALIGN.
- TO ADJUST----WITH DETENTING NUT CLAMP SCREW (FRONT & REAR PLATE) FRICTION TIGHT, MOVE CLAMP SCREWS TO THEIR EXTREME LOWER RIGHT POSITION THEN TIGHTEN SCREWS. LOOSEN DETENT BRACKET AND SPRING PLATE MOUNTING NUTS. PLACE COVER ON UNIT AND POSITION HORIZONTALLY TO MEET THE REQUIREMENTS. RETIGHTEN MOUNTING NUTS.

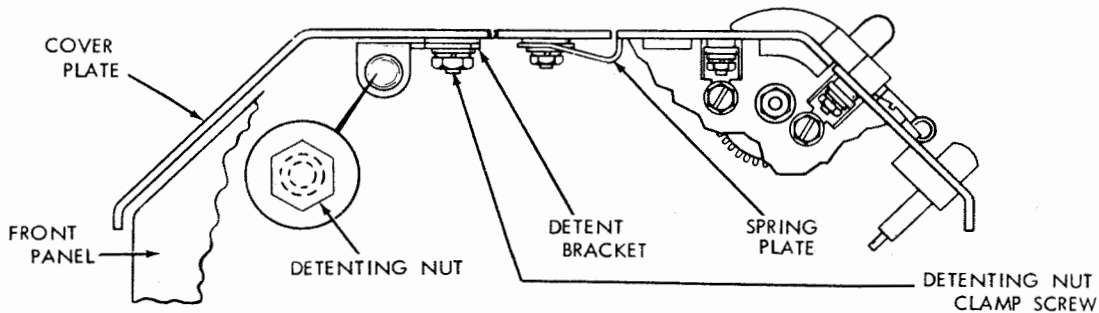

Figure 6-22. Top Plate and Cover Plate Mounting

TAPE-OUT CONTACT ASSEMBLY

REQUIREMENT

(COVER PLATE AND TOP PLATE REMOVED: START-STOP SWITCH IN STOP POSITION: REMOVAL OF TAPE GUIDE PLATE OPTIONAL.)
START-STOP SWITCH IN STOP POSITION. WITH TAPE-OUT SPRING BRACKET FRICTION TIGHT, MOVE BRACKET DOWNWARD UNTIL TAPE-OUT PIN CLEARS INSULATED PORTION OF CONTACT SWINGER.

(1) WITH GRAM SCALE APPLIED AS SHOWN, MIN. 8 GRAMS ---- MAX. 15 GRAMS, TO SEPARATE NORMALLY CLOSED CONTACTS.

TO ADJUST REMOVE BAIL SPRING AND CONTACT ASSEMBLY. FORM THE CONTACT SWINGER WITH THE 110445 SPRING BENDER.

(2) CLEARANCE BETWEEN NORMALLY OPEN CONTACTS, MIN. 0.008 INCH ---- MAX. 0.015 INCH.

TO ADJUST FORM UPPER CONTACT SPRING USING THE 110445 SPRING BENDER.

NOTE: REPLACE CONTACT ASSEMBLY WITH SWINGER OVER TAPE-OUT PIN EXTENSION. PLACE SPRING BRACKET SHOULDER BUSHING ON UPPER HOLE AND THE WASHER ON LOWER MOUNTING HOLE.

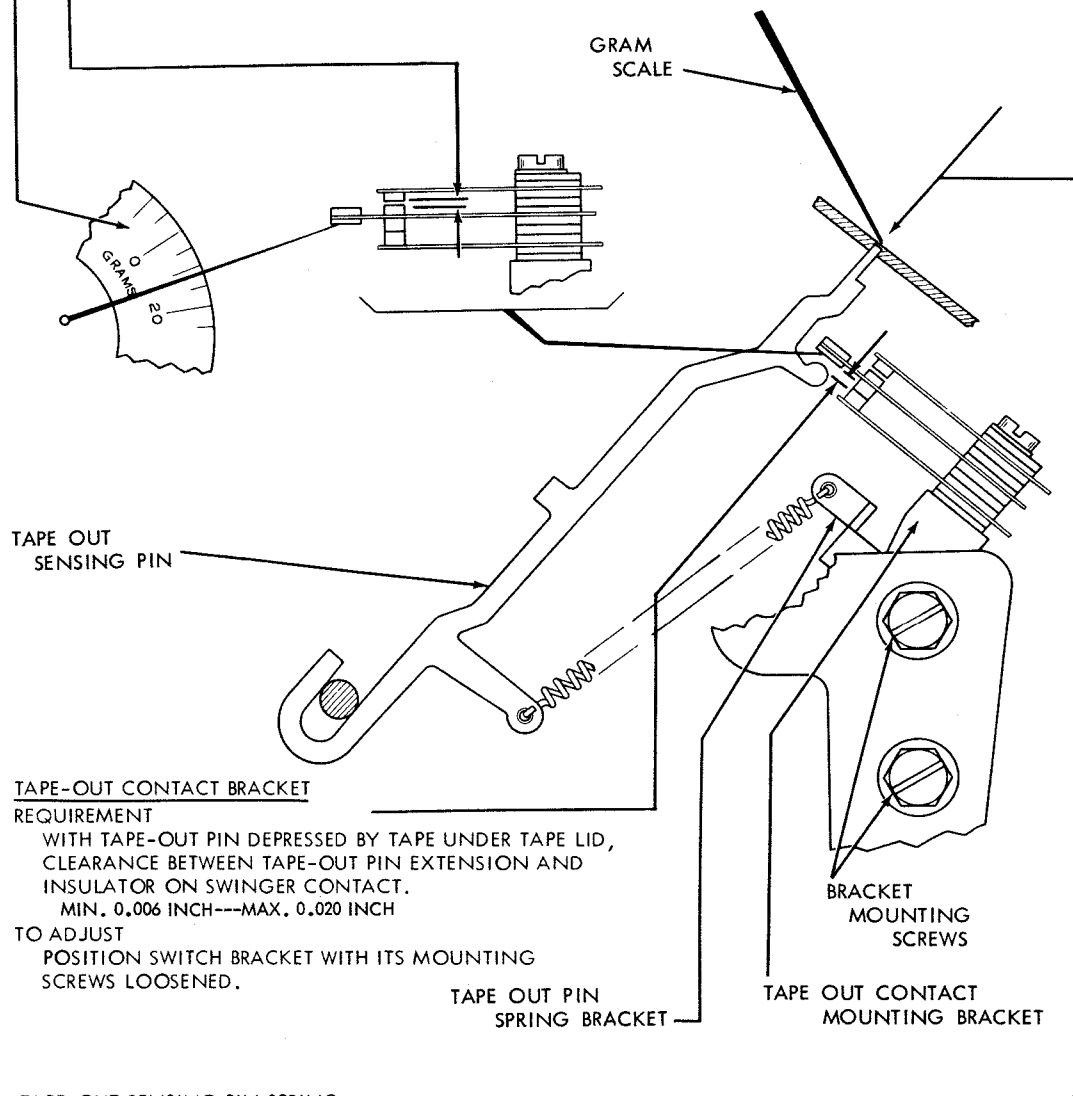

TAPE-OUT CONTACT BRACKET

REQUIREMENT

WITH TAPE-OUT PIN DEPRESSED BY TAPE UNDER TAPE LID, CLEARANCE BETWEEN TAPE-OUT PIN EXTENSION AND INSULATOR ON SWINGER CONTACT.
MIN. 0.006 INCH---MAX. 0.020 INCH

TO ADJUST POSITION SWITCH BRACKET WITH ITS MOUNTING SCREWS LOOSENED.

TAPE-OUT SENSING PIN SPRING

REQUIREMENT

WITH START-STOP LEVER IN RUN POSITION, APPLY GRAM SCALE TO TIP END OF SENSING PIN.

MIN. 38 GRAMS ---- MAX. 45 GRAMS, TO MOVE PIN TO A POSITION FLUSH WITH TAPE GUIDE PLATE.

TO ADJUST

WITH CONTACT BRACKET LOWER MOUNTING SCREW LOOSENED, POSITION THE SPRING BRACKET.

Figure 6-23. Tape-Out Contact Assembly

TAPE OUT SENSING PIN

REQUIREMENTS

1. WITH START-STOP LEVER IN FREE WHEELING OR STOP POSITION, TIP OF TAPE-OUT PIN SHOULD BE FLUSH----TO----0.010 INCH BELOW TOP SURFACE OF TAPE GUIDE PLATE. TO ADJUST: PLACE START-STOP LEVER IN STOP POSITION. WITH STOP ARM CLAMP SCREW FRICTION TIGHT, POSITION THE STOP ARM.
 2. WITH START-STOP LEVER IN RUN POSITION, CLEARANCE AS SHOWN SHOULD BE AT LEAST 0.055 INCH. TO ADJUST: PLACE START-STOP LEVER IN RUN POSITION AND LOOSEN TAPE-OUT BAIL CLAMP SCREW. POSITION EXTENSION ARM WITH TOMMY WRENCH OR SIMILAR TOOL.
- NOTE: RECHECK REQUIREMENT NO. 1.

DEPRESSOR BAIL TORSION SPRING

REQUIREMENT: WITH TAPE-OUT BAIL SPRING UNHOOKED, START-STOP LEVER IN ITS STOP POSITION, MIN. 3 OZS. ---- MAX. 5-1/2 OZS. TO START INTERMEDIATE TAPE-OUT BAIL MOVING AWAY FROM TAPE-OUT PIN DEPRESSOR BAIL.

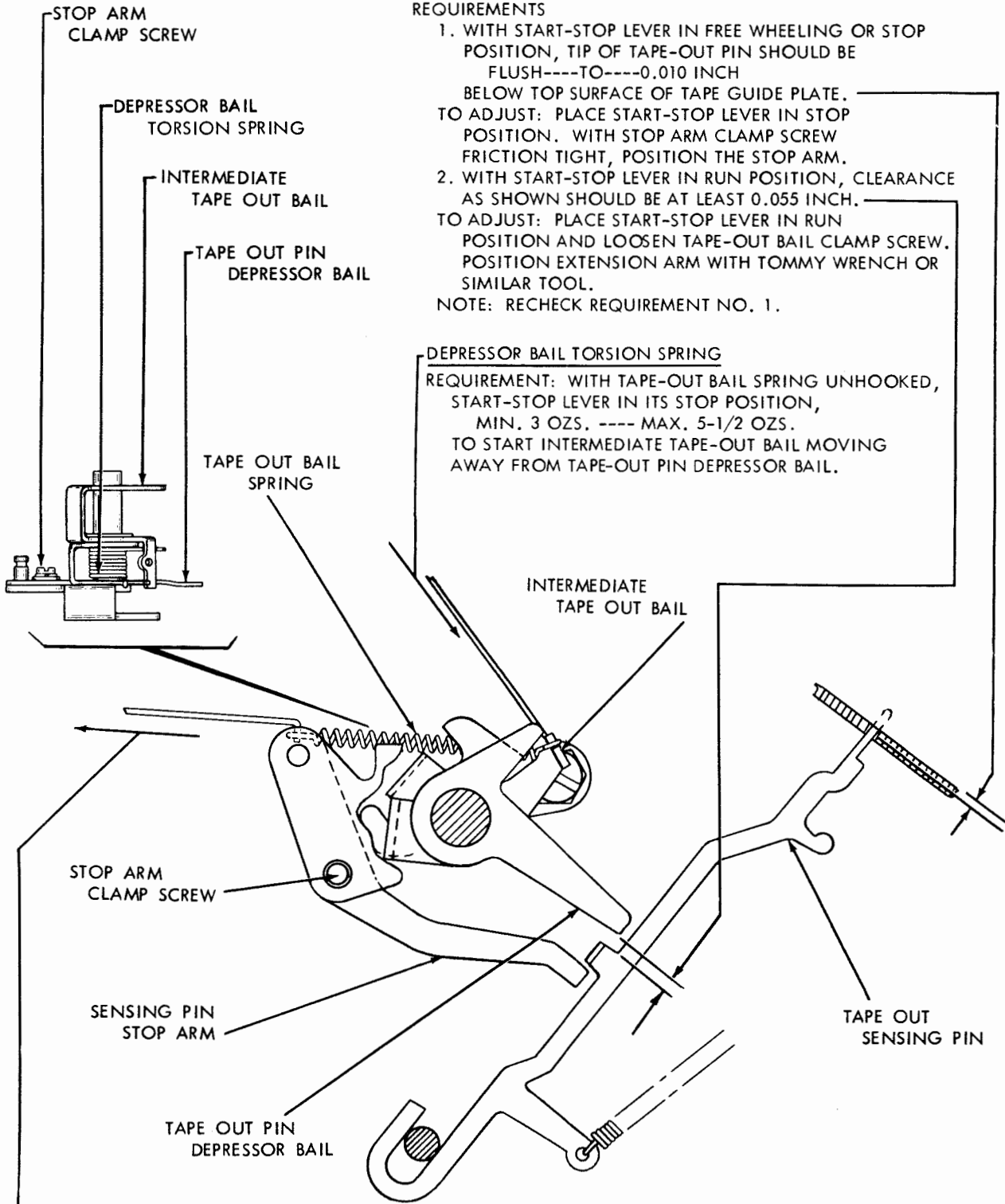

INTERMEDIATE TAPE OUT BAIL SPRING

REQUIREMENT --- WITH START-STOP LEVER IN ITS RUN POSITION, HOOK SPRING SCALE IN LOOP. MIN. 3 OZS. ---- MAX. 5 OZS., TO PULL SPRING TO ITS INSTALLED LENGTH.

Figure 6-24. Tape-Out Sensing Pin

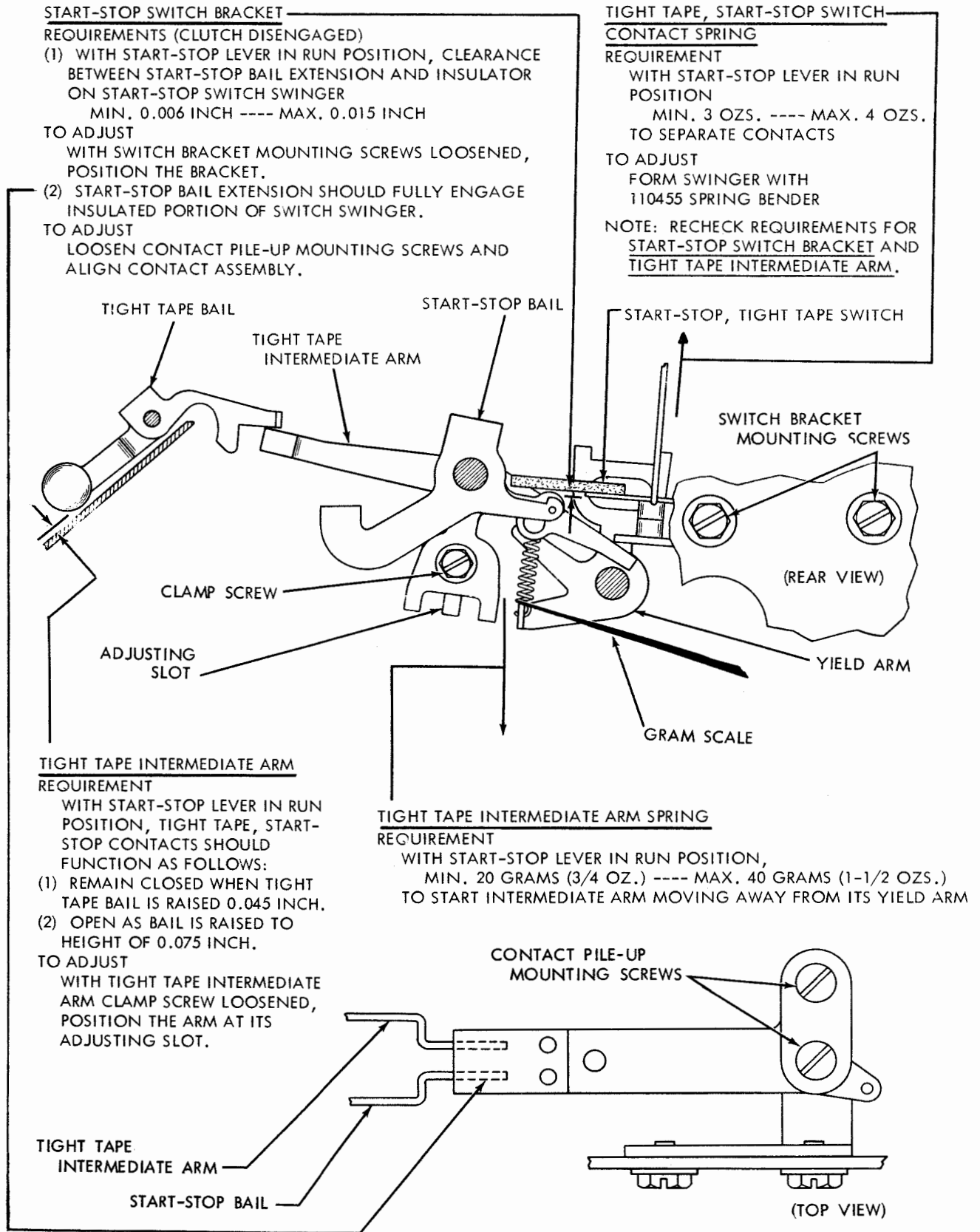

Figure 6-25. Start-Stop Switch Assembly

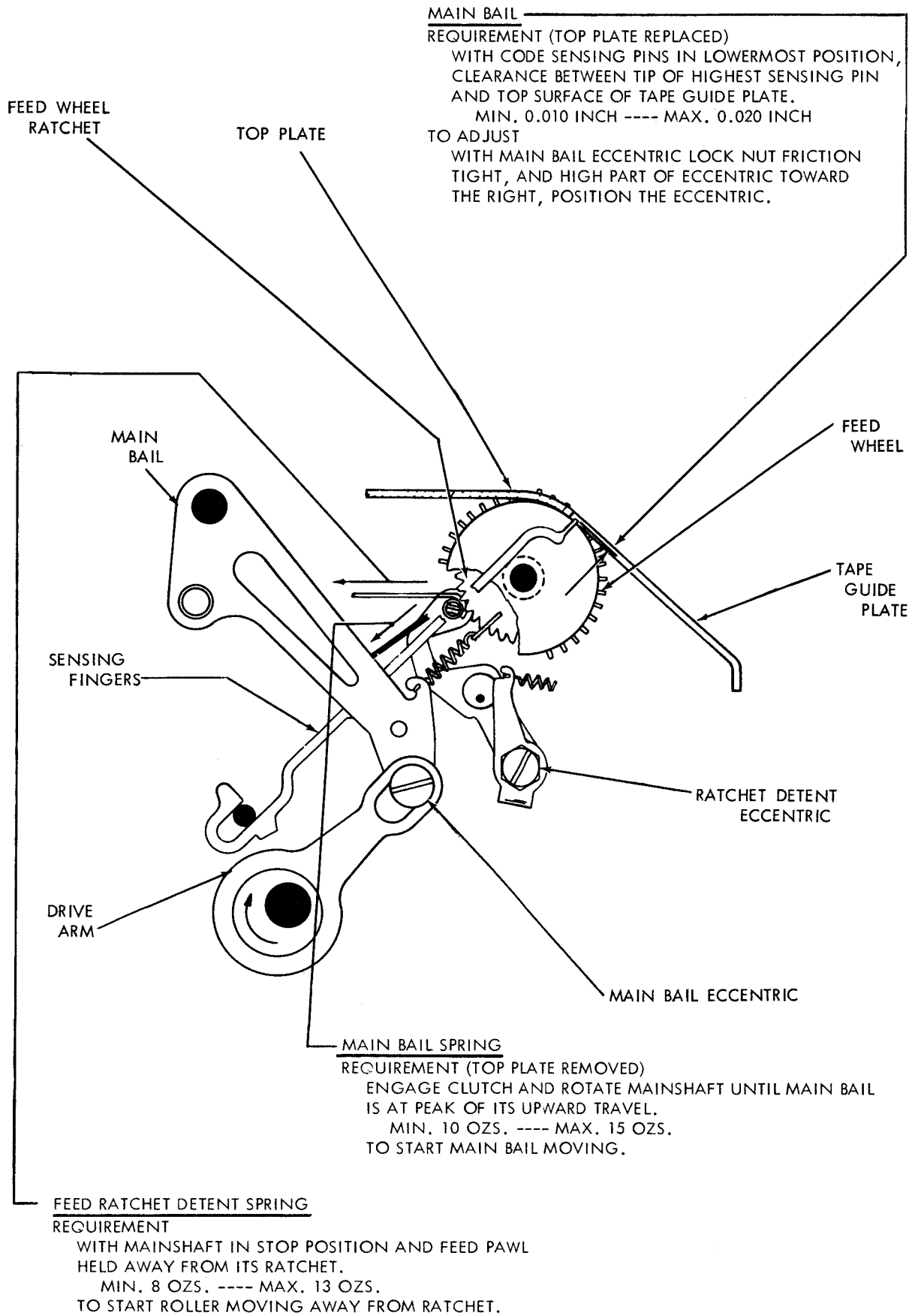

Figure 6-26. Main Bail Assembly

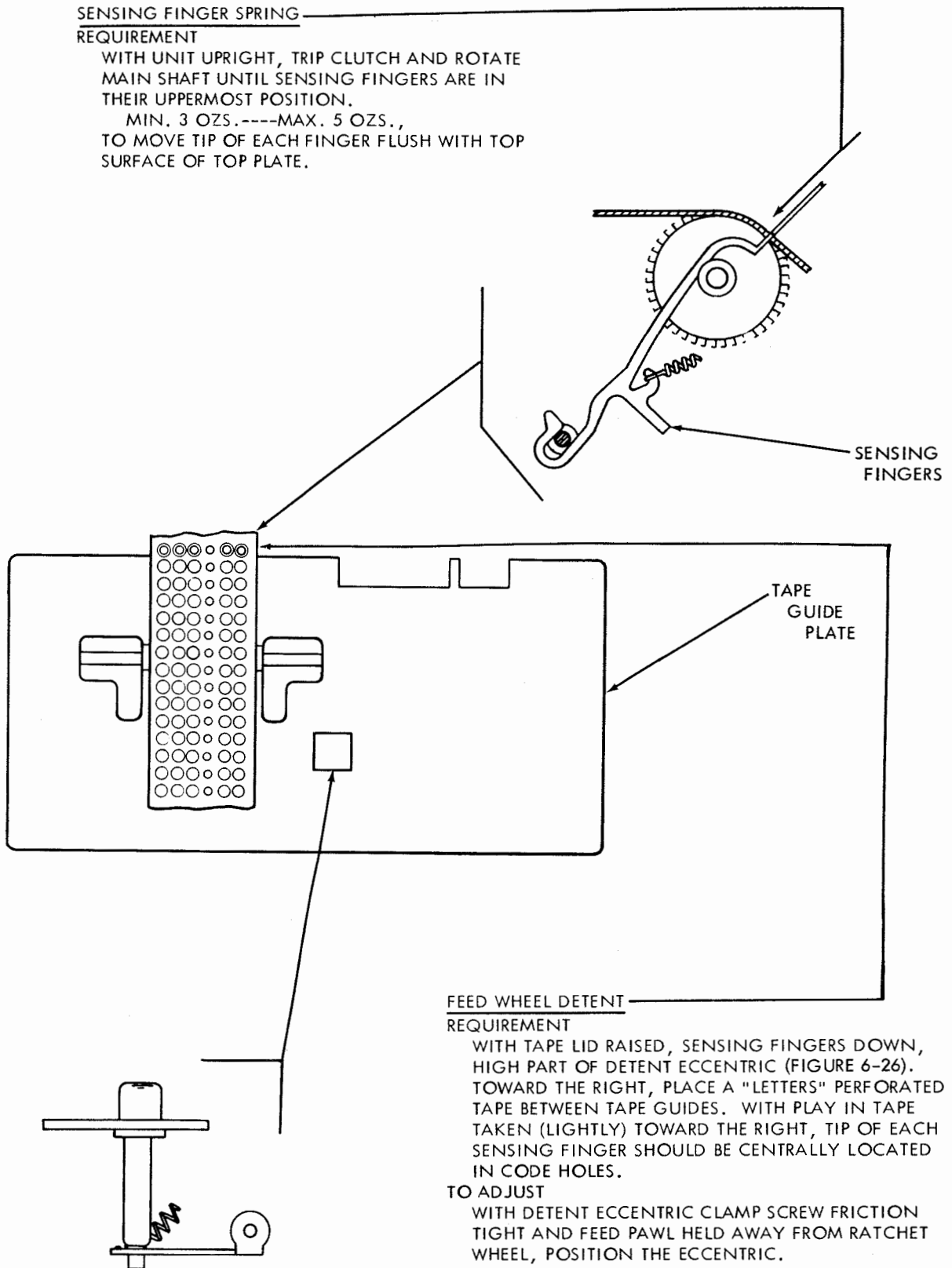

Figure 6-27. Code Sensing Fingers

FEED PAWL

REQUIREMENT----(TOP PLATE REMOVED) - WITH HIGH PART OF ECCENTRIC TOWARD THE RIGHT AND SENSING FINGERS IN THEIR LOWERMOST POSITION, CLEARANCE BETWEEN FEED PAWL AND RATCHET TOOTH JUST ENGAGED.

SOME _____ TO _____ 0.003 INCH
TO ADJUST----WITH ECCENTRIC SCREW LOCK NUT LOOSENED, POSITION THE SCREW. RE-CHECK REQUIREMENT AT FOUR POSITIONS OF RATCHET APPROXIMATELY 90 DEGREES APART.

FEED PAWL SPRING

REQUIREMENT----WITH UNIT TILTED TOWARD THE LEFT AND MAINSHAFT IN ITS STOP POSITION. MIN. 2 OZS. _____ MAX. 3-1/2 OZS. TO START PAWL MOVING.

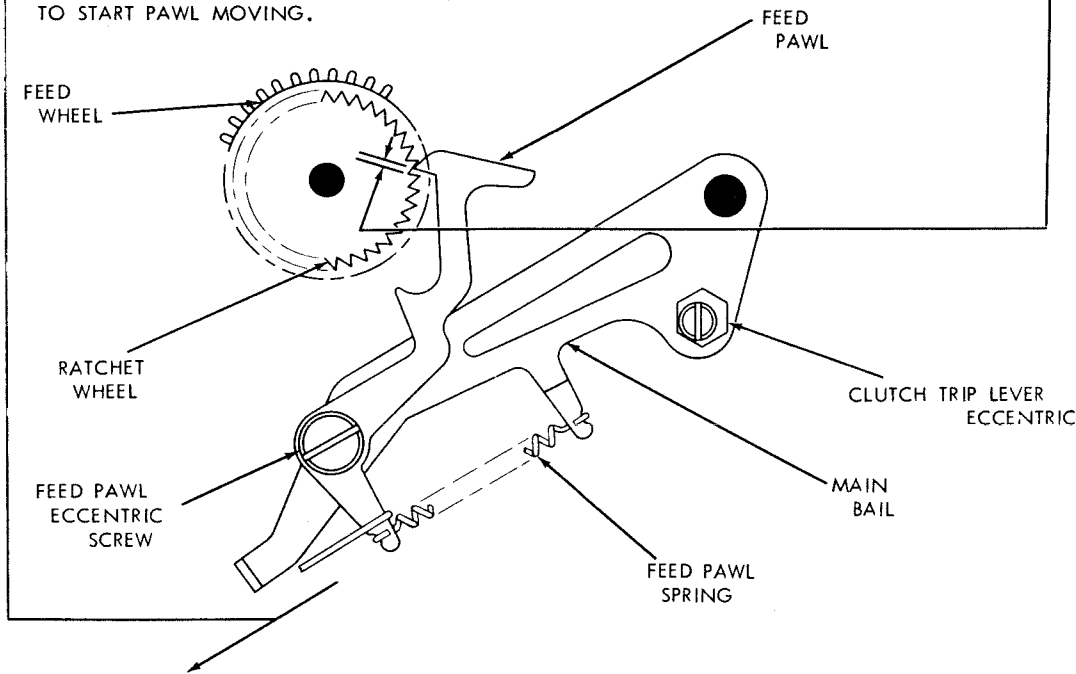

TRANSFER LEVER

TRANSFER LEVER GUIDE POST

TRANSFER LEVER SPRING

REQUIREMENT----WITH UNIT RESTING ON ITS REAR PLATE AND MAINSHAFT IN ITS STOP POSITION. MIN. 1/2 OZ-----MAX. 1-1/2 OZS. TO START EACH LEVER MOVING.

TRANSFER LEVER SPRING

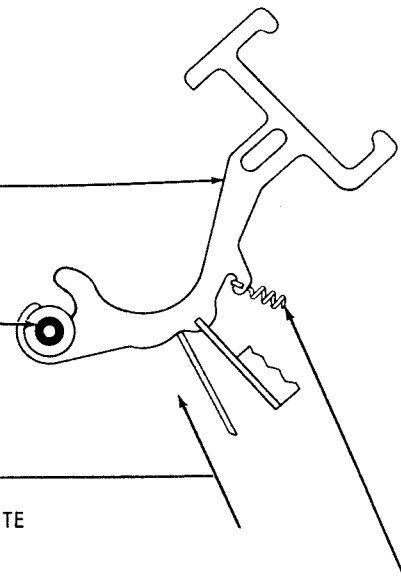

Figure 6-28. Feed Pawl Mechanism and Transfer Lever Spring

MAIN BAIL TRIP LEVER

REQUIREMENT (TOP PLATE REPLACED)

WITH CLUTCH DISENGAGED AND MAINSHAFT IN ITS STOP POSITION, TIP OF HIGHEST SENSING FINGER SHOULD BE FLUSH ---- TO ---- 0.005 INCH BELOW TOP SURFACE OF TAPE GUIDE PLATE.

TO ADJUST

WITH CLAMP NUTS (FRONT AND REAR) THAT SECURE THE TRANSFER LEVER GUIDE POST LOOSENED, ROTATE POST SO THAT ITS ECCENTRIC (REAR END OF POST) POSITIONS THE TRIP LEVER TO MEET REQUIREMENT.

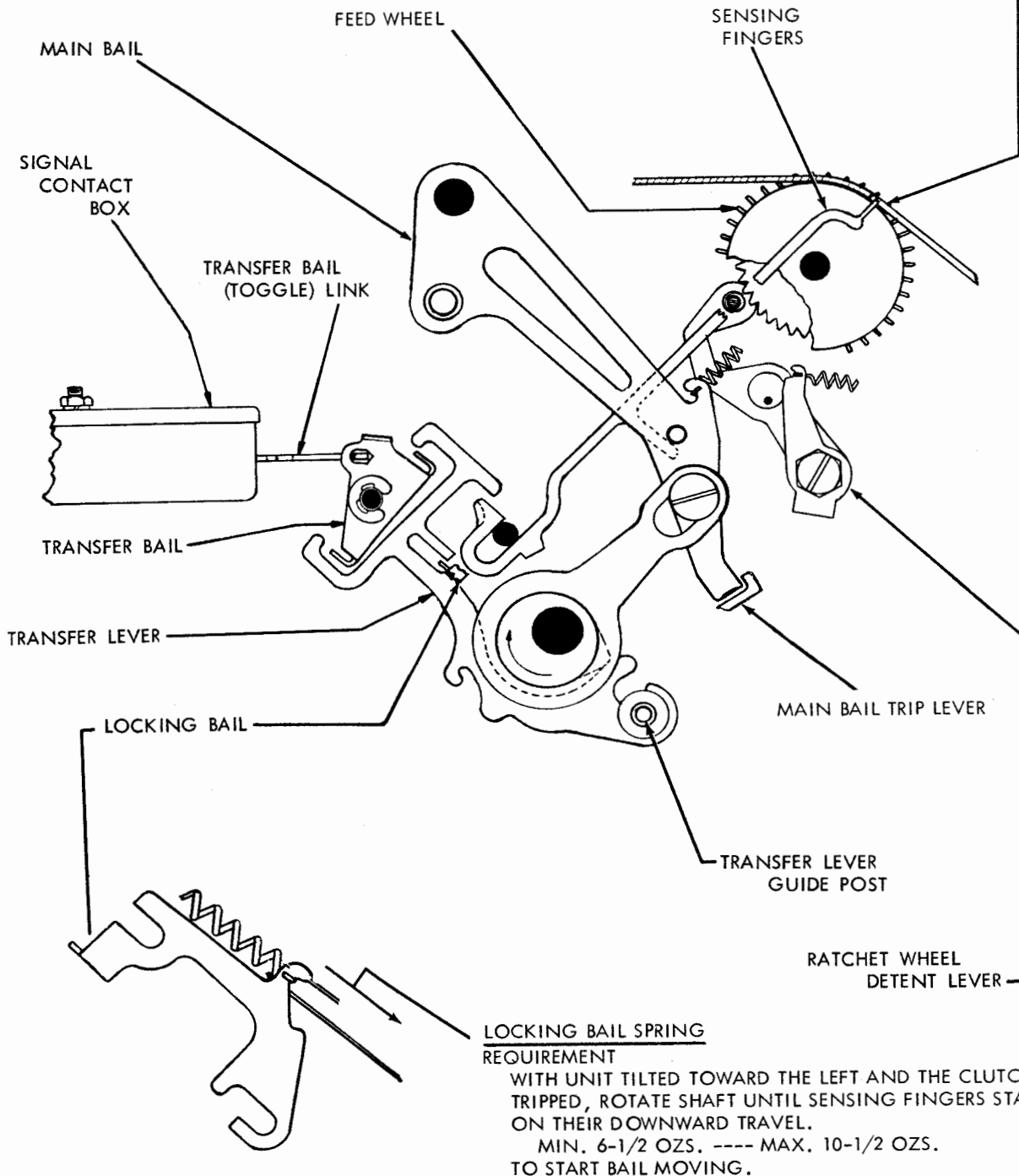
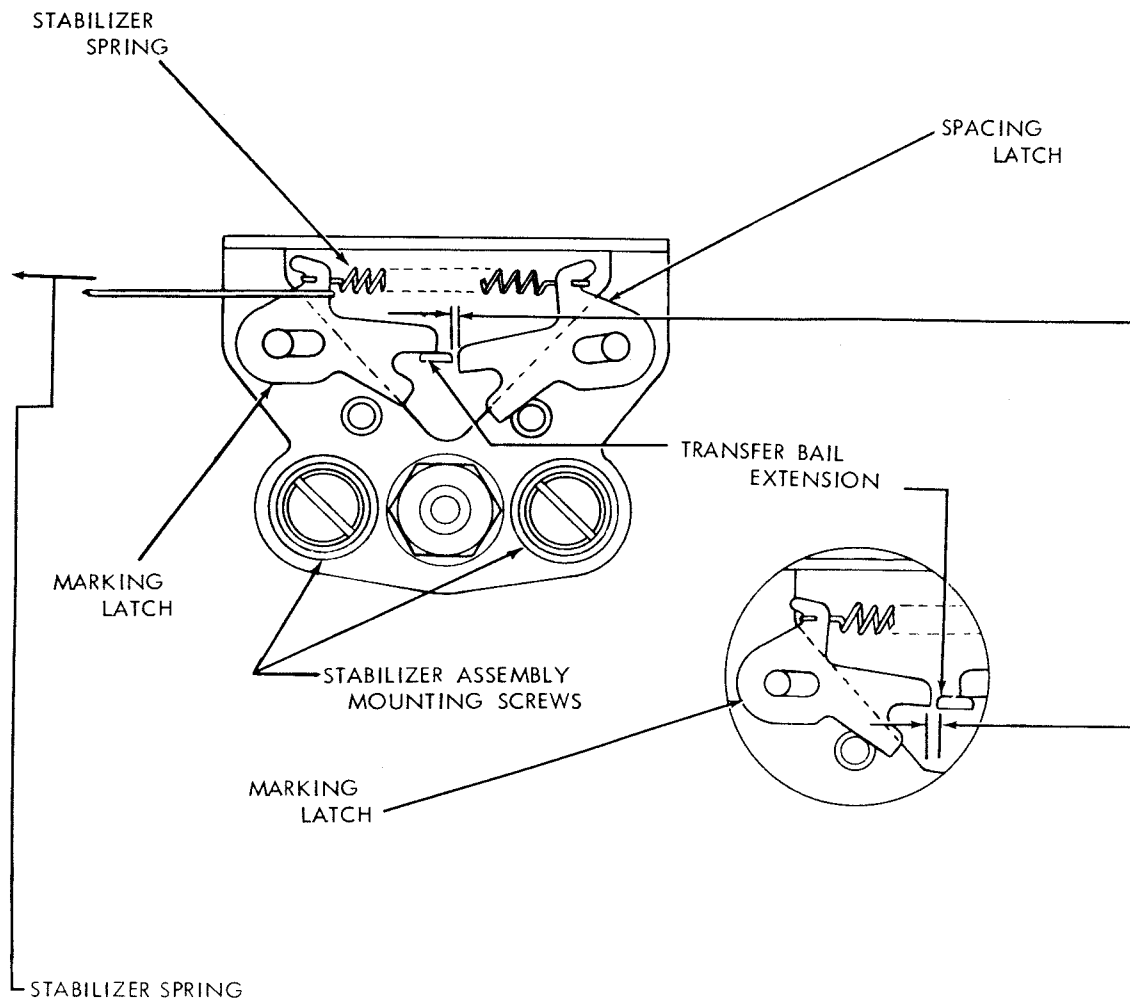

Figure 6-29. Main Bail Trip Assembly

TRANSFER BAIL STABILIZER

REQUIREMENT --- (1) WITH A "LETTERS" COMBINATION SELECTED, ROTATE MAINSHAFT UNTIL #3 TRANSFER LEVER IS ON HIGH PART OF ITS CAM. CHECK CLEARANCE BETWEEN SIDE OF TRANSFER BAIL EXTENSION AND ITS LATCH. (2) REPEAT ABOVE PROCEDURE WITH A "BLANKS" COMBINATION SELECTED AND CHECK THE CLEARANCE ON OTHER LATCH. CLEARANCE IN MARKING AND SPACING POSITION SHOULD BE EQUAL WITHIN 0.002 INCH.
TO ADJUST --- WITH STABILIZER ASSEMBLY MOUNTING SCREWS FRICTION TIGHT, POSITION THE ASSEMBLY.

NOTE --- LATCHES SHOULD DROP IN PLACE AS OTHER TRANSFER LEVERS CAM THE TRANSFER BAIL.



REQUIREMENT----WITH UNIT UPRIGHT AND MAINSHAFT IN STOP POSITION.
MIN. 2-1/2 OZS. — MAX. 5 OZS.
TO START STABILIZER LATCH MOVING.

Figure 6-30. Transfer Bail Stabilizer

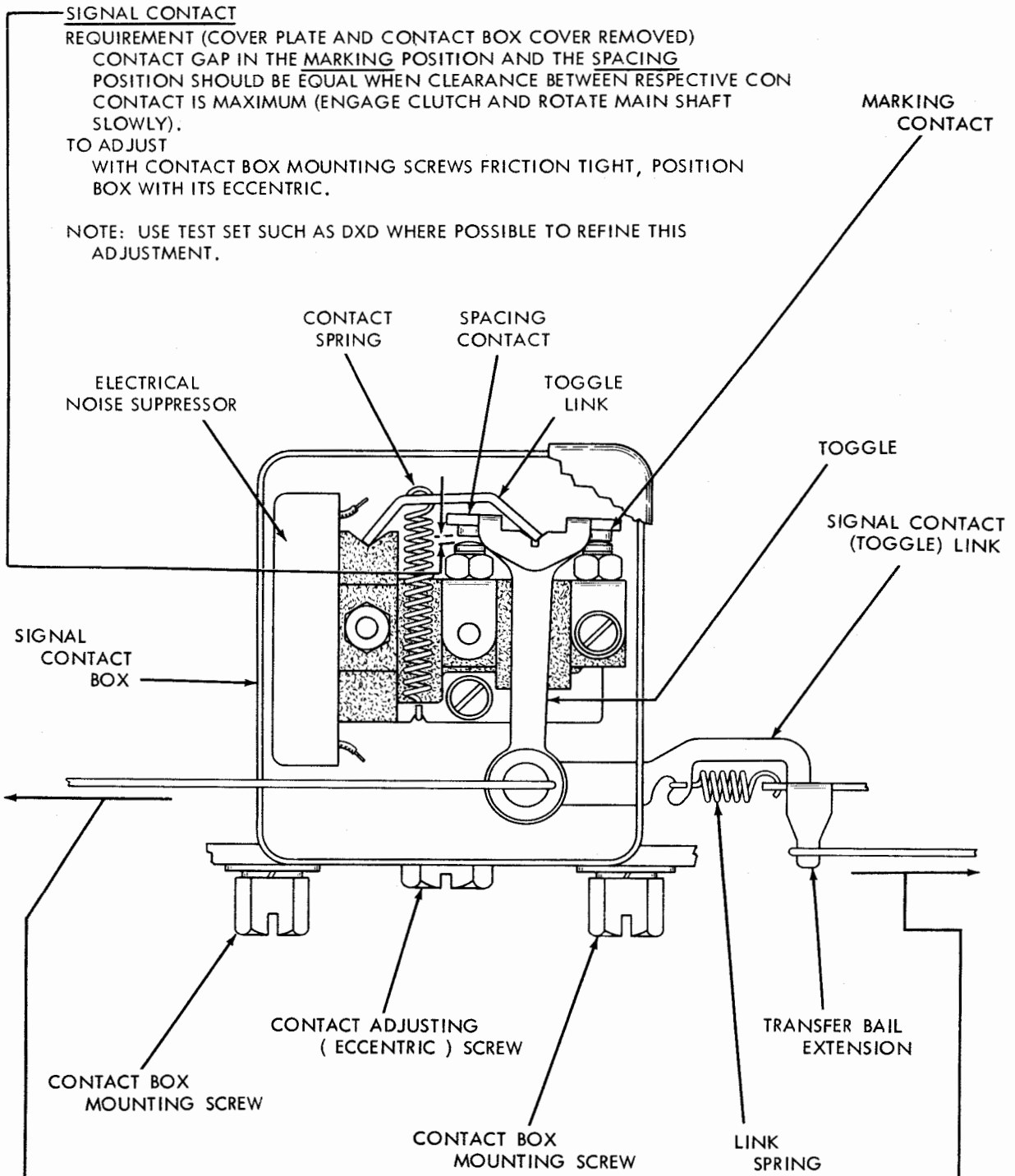

SIGNAL CONTACT REQUIREMENT (COVER PLATE AND CONTACT BOX COVER REMOVED)
 CONTACT GAP IN THE MARKING POSITION AND THE SPACING POSITION SHOULD BE EQUAL WHEN CLEARANCE BETWEEN RESPECTIVE CONTACT IS MAXIMUM (ENGAGE CLUTCH AND ROTATE MAIN SHAFT SLOWLY).
 TO ADJUST WITH CONTACT BOX MOUNTING SCREWS FRICTION TIGHT, POSITION BOX WITH ITS ECCENTRIC.
 NOTE: USE TEST SET SUCH AS DXD WHERE POSSIBLE TO REFINE THIS ADJUSTMENT.

SIGNAL CONTACT SPRING REQUIREMENT
 WITH MAINSHAFT IN STOP POSITION AND COVER OF CONTACT BOX REMOVED, UNHOOK TOGGLE LINK SPRING AND MOVE TRANSFER BAIL TO SPACING POSITION (RIGHT).
 MIN. 2 OZS. ---- MAX. 3-1/2 OZS.
 TO OPEN SPACING CONTACTS (LEFT).

SIGNAL CONTACT LINK SPRING REQUIREMENT
 WITH MAINSHAFT IN STOP POSITION AND STABILIZER SPRING UNHOOKED, MOVE LATCHES AWAY FROM TRANSFER BAIL EXTENSION (FIGURE 6-30). HOLD TOGGLE FIRMLY AGAINST THE CONTACTS.
 MIN. 6 OZS. ---- MAX. 9 OZS.
 TO START TRANSFER BAIL EXTENSION MOVING.

Figure 6-31. Signal Generator

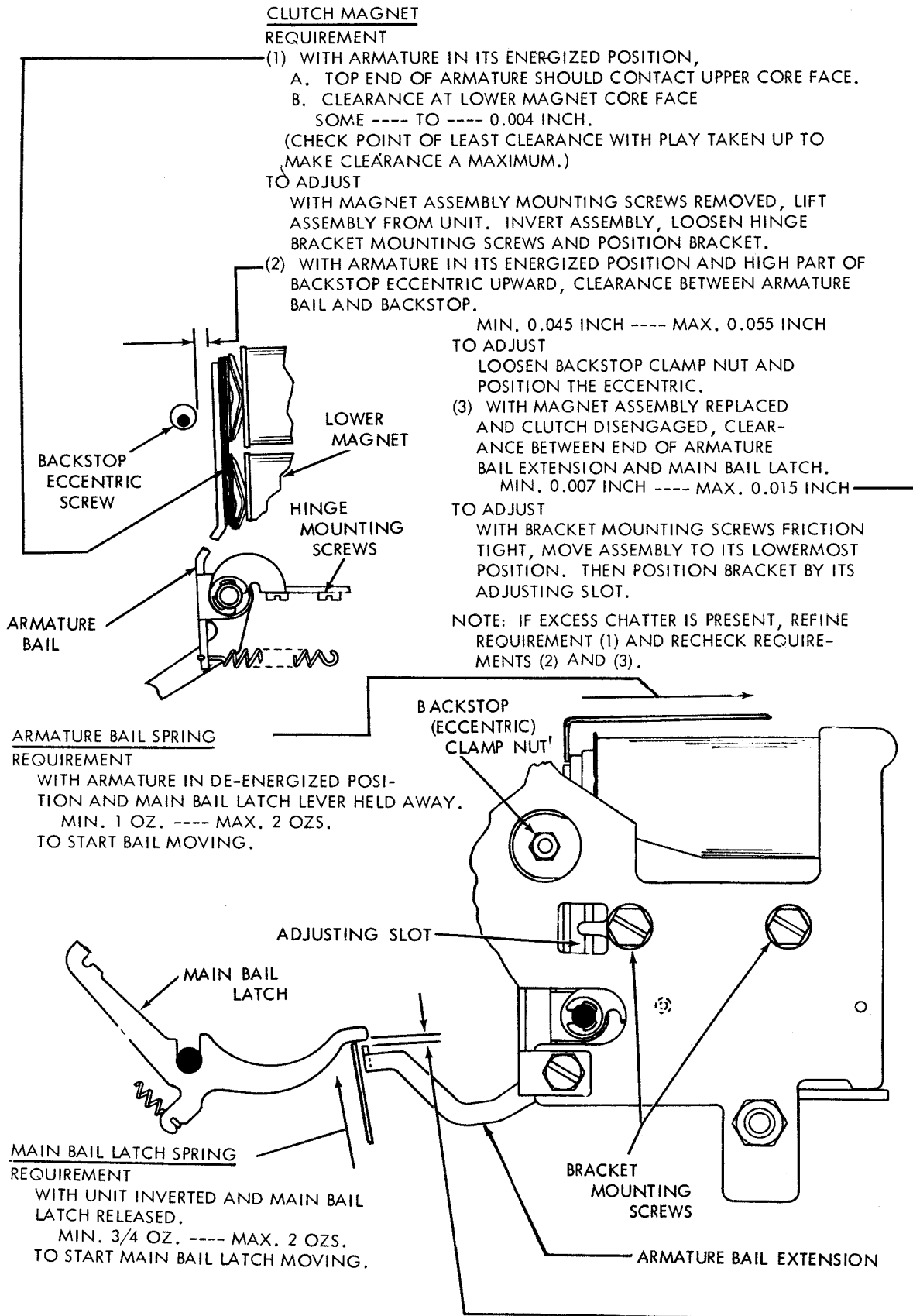
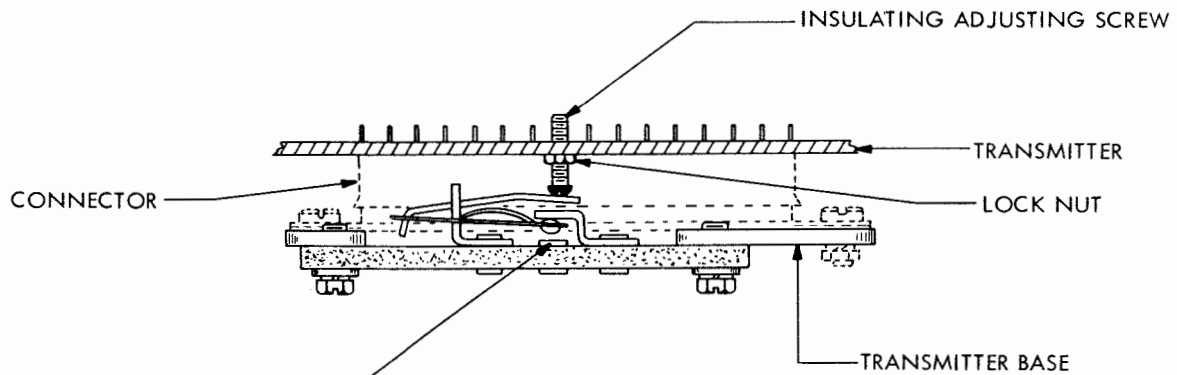
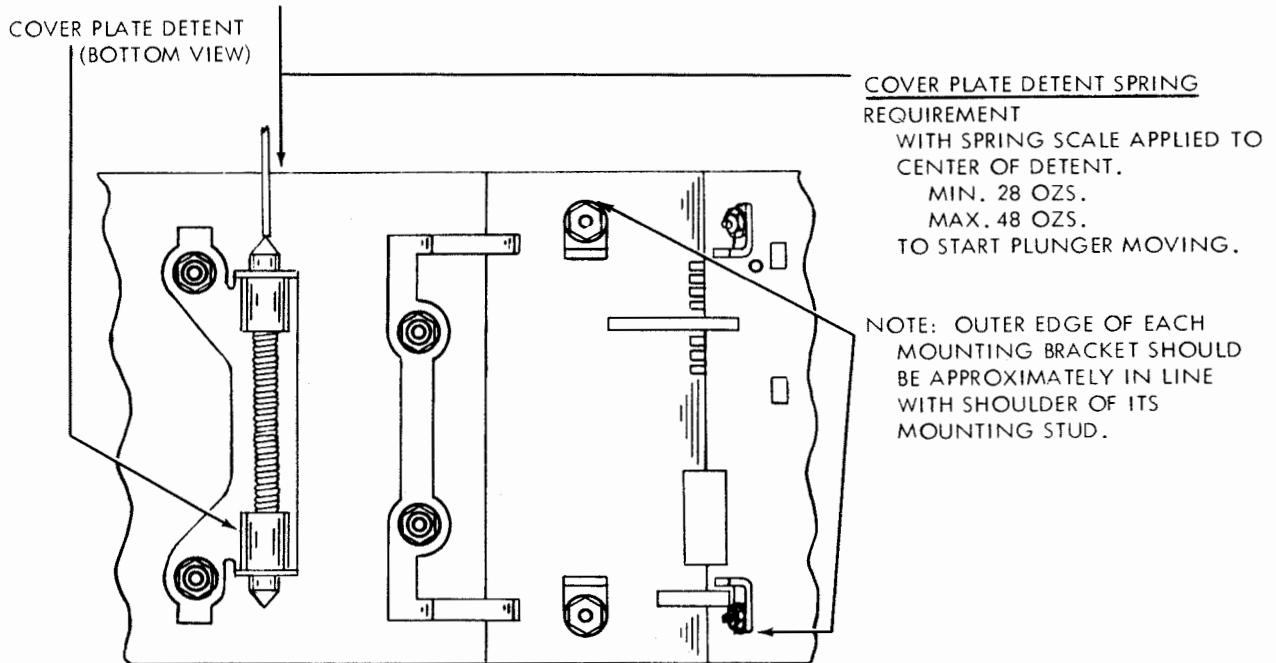

Figure 6-32. Clutch Trip Magnet Assembly



LINE SHUNT SWITCH
REQUIREMENT
WITH THE TRANSMITTER MOUNTED ON
THE BASE, THE LINE SHUNT SWITCH
SHOULD OPEN. WHEN THE TRANSMITTER
IS REMOVED FROM THE BASE, THE SWITCH
SHOULD CLOSE.
TO ADJUST
ROTATE THE INSULATING ADJUSTING
SCREW WITH ITS LOCK NUT LOOSENED.

Figure 6-33. Cover Plate Detent and TT-187A/UG Line Shunt Switch

STANDARD BASE (TT-187/UG)

(A) DISTRIBUTOR-TRANSMITTER GEAR

REQUIREMENT --- (GEAR GUARD REMOVED).
THERE SHOULD BE A PERCEPTIBLE AMOUNT OF
BACKLASH BETWEEN MAINSHAFT DRIVEN GEAR
AND INTERMEDIATE DRIVING GEAR.
TO ADJ

TO ADJUST --- WITH DISTRIBUTOR-TRANSMITTER
MOUNTING SCREWS (3) LOOSENED, POSITION
THE UNIT ON ITS BASE.

NOTE
IN A SIMILAR MANNER, GEARS
DRIVEN BY A SHAFT CONNECTED TO
THE KEYBOARD MOTOR SHOULD ALIGN
AND HAVE PERCEPTIBLE BACKLASH.

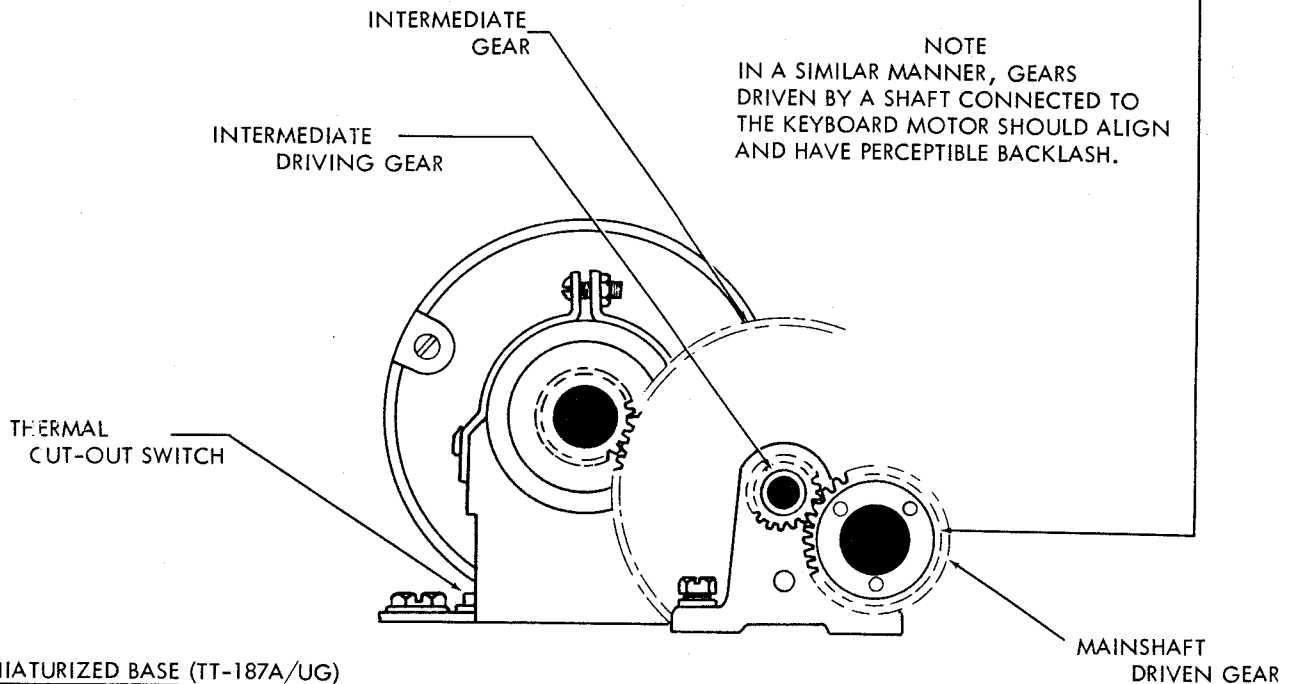

MINIATURIZED BASE (TT-187A/UG)

INTERMEDIATE SHAFT ADJUSTMENT

- (1) REQUIREMENT
THE CLEARANCE BETWEEN THE MOTOR PINION
AND THE INTERMEDIATE GEAR
MIN. 0.015 INCH
MAX. 0.020 INCH
AT POINT WHERE BACKLASH IS LEAST
TO ADJUST
POSITION THE INTERMEDIATE SHAFT ASSEMBLY
TO THE FORWARD PLATE LOOSENED.
- (2) REQUIREMENT
THERE SHOULD BE A PERCEPTIBLE AMOUNT OF
BACKLASH BETWEEN THE INTERMEDIATE
DRIVING GEAR AND THE DISTRIBUTOR-
TRANSMITTER GEAR
TO ADJUST
POSITION THE DISTRIBUTOR-TRANSMITTER ON
ITS BASE WITH ITS THREE MOUNTING SCREWS
LOOSENED.

NOTE

SHOULD THE ROTOR OF THE SYNCHRONOUS MOTOR
BECOME BLOCKED FOR SEVERAL SECONDS BY AN
OVERLOAD, THE THERMAL CUT-OUT SWITCH WILL
DE-ENERGIZE THE MOTOR UNTIL THE MANUAL RESET
BUTTON IS DEPRESSED. HOWEVER, ALLOW AT LEAST
5 MINUTES FOR THE MOTOR TO COOL BEFORE
ATTEMPTING TO RESET THE SWITCH AND START THE
MOTOR.

*SEE T-1 FOR REF. TO ~~FIGURE~~
Figures - 6-34A, 6-34B*

Figure 6-34. Intermediate Gears

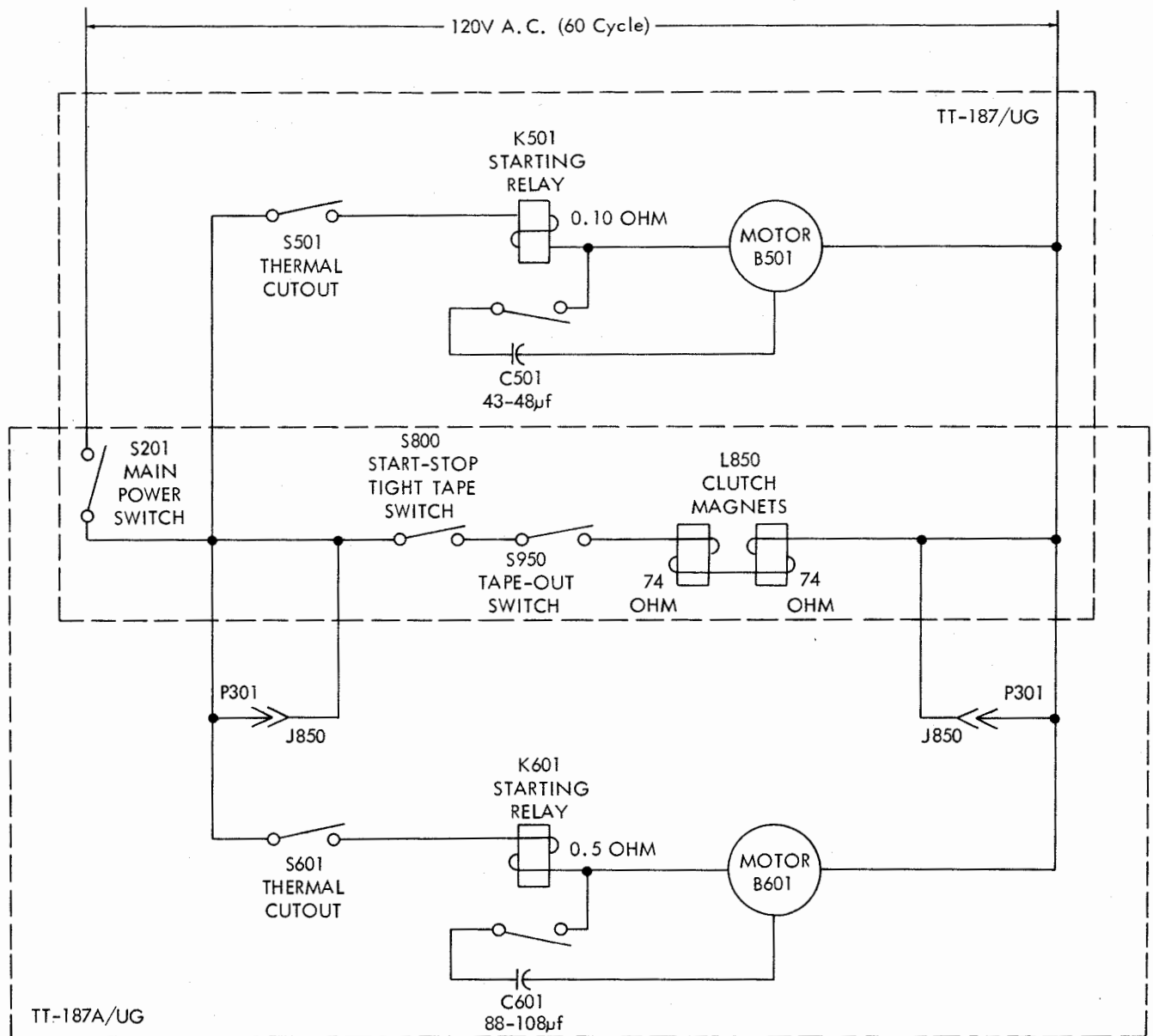

Figure 6-35. Main Power Distribution Diagram

SEE T-1 PAGE 8 FOR REF. TO FOLLOWING

TABLE 6-1. WINDING DATA

L850 (74 ohms) 262M (210 ohms)

REFERENCE DESIGNATION	TELETYPE PART NUMBER	MANUFACTURER AND MFR. PART NUMBER	WINDING	WIRE SIZE	TURNS	DC RESISTANCE (OHMS)	HIPOT AC VOLTS	REMARKS
K501	151923	Teletype 151923	Single	No. 39	600	1250	500	Motor Start Relay
K601	173425	Teletype 173425	Single	No. 39	600	1250	500	Motor Start Relay
L850	256M	Teletype 256M	Single	No. 32	2600	74	500	Clutch Magnet

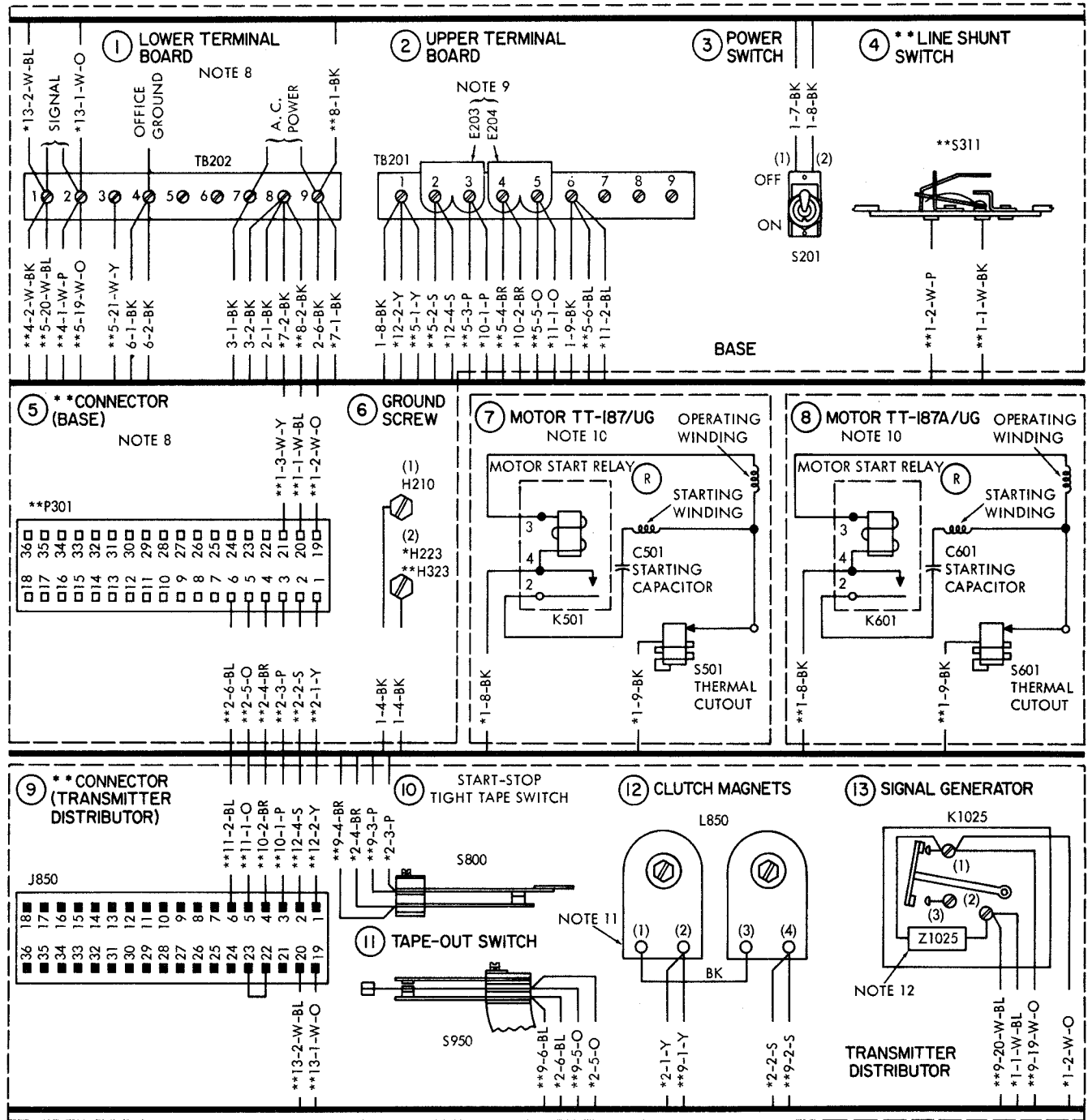

NO.	NOTES
1	<p>WIRING LEGEND:</p> <p>WIRE COLOR CODE</p> <p>DISTANT TERMINAL AREA → 1-1-BK</p> <p>DISTANT TERMINAL DESIGNATION</p>
2	<p>COLOR CODE:</p> <p>BK - BLACK</p> <p>BL - BLUE</p> <p>BR - BROWN</p> <p>O - ORANGE</p> <p>P - PURPLE</p> <p>S - SLATE</p> <p>W-BK - WHITE-BLACK</p> <p>W-BL - WHITE-BLUE</p> <p>W-O - WHITE-ORANGE</p> <p>W-P - WHITE-PURPLE</p> <p>W-Y - WHITE-YELLOW</p> <p>Y - YELLOW</p>
3	ALL CONNECTIONS VIEWED FROM SOLDERED END
4	ALL CONTACTS SHOWN IN UNOPERATED POSITION
5	TERMINAL DESIGNATIONS IN PARENTHESIS ARE NOT MARKED ON COMPONENTS
6	* - PECULIAR TO DISTRIBUTOR TRANSMITTER SETS TT-187/UG
7	** - PECULIAR TO TRANSMITTER DISTRIBUTOR SETS TT-187A/UG
8	TERMINALS **1-3-W-Y or **5-21-W-Y RESERVED FOR POLAR SIGNAL WITH E203 AND E204 TERMINAL STRAPS CONNECTED AS SHOWN, CLUTCH MAGNETS, TAPE-OUT SWITCH AND START-STOP TIGHT TAPE SWITCH WILL BE WIRED IN NEW SERIES
9	MOTOR LEADS OF SAME COLOR ARE INTERCHANGEABLE
10	115V AC ± 10 PER CENT TO BE USED ON CLUTCH MAGNETS. IF DC IS USED, CURRENT MUST BE LIMITED BY EXTERNAL RESISTANCE TO 100 MA (COIL RESISTANCE = 74 OHM EACH). DISCONNECT ONE ARC SUPPRESSOR LEAD WHEN TESTING SIGNAL GENERATOR
11	
12	

6-40

Figure 6-36. TT-187/UG or TT-187A/UG Actual Wiring Diagram

SEE CHANGE T-1 PAGE 8 FOR REF. TO WIRING ORIGINAL
 Diagrams 4 2644D, AND FIG. 6-36A

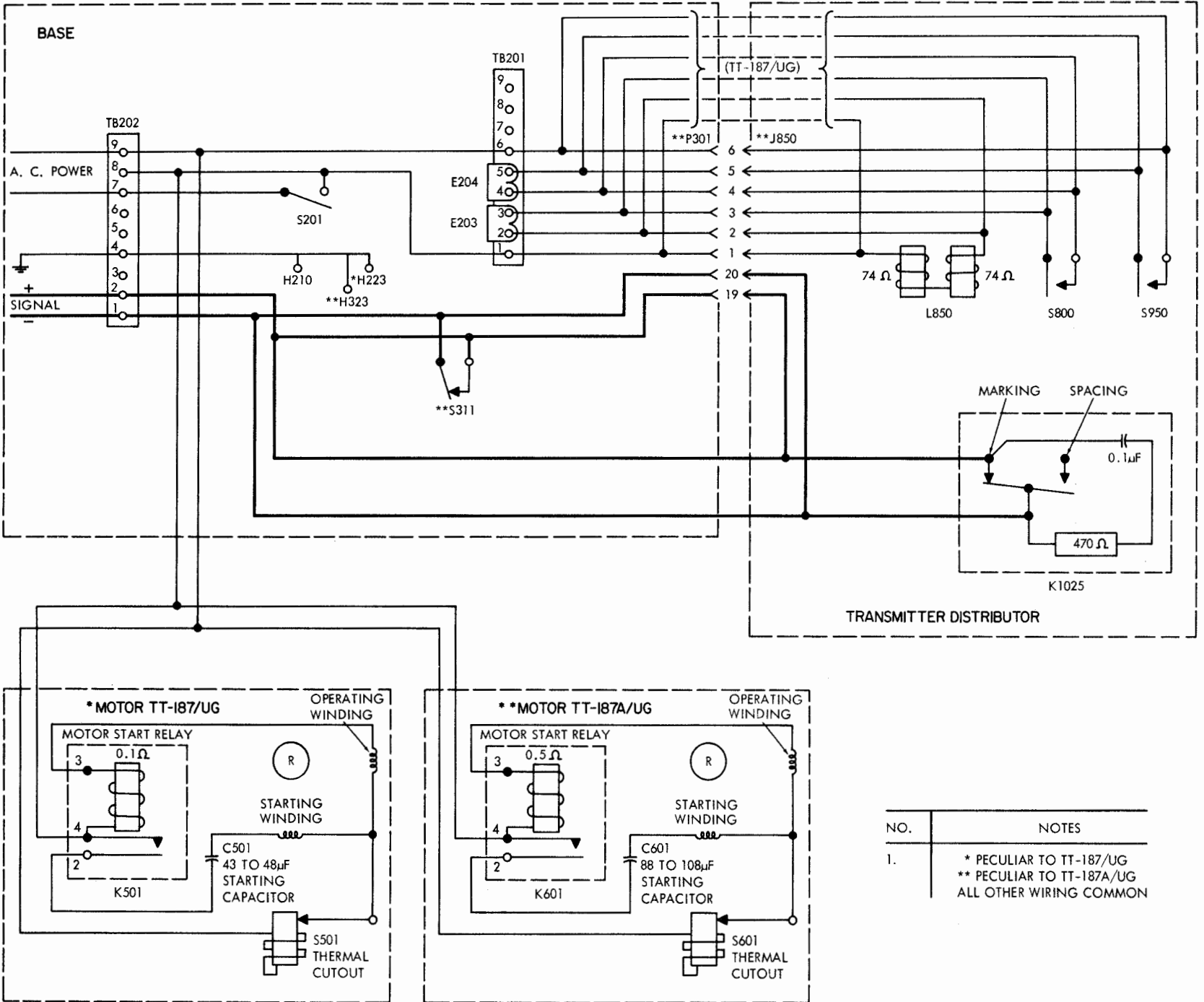

NO.	NOTES
1.	* PECULIAR TO TT-187/UG ** PECULIAR TO TT-187A/UG ALL OTHER WIRING COMMON

Figure 6-37. TT-187/UG or TT-187A/UG Schematic Wiring Diagram

ORIGINAL

SEE T-1 FOR REF TO ~~GENERATED~~ FOLLOWING
Fig. 6-37 A L850 (74 Ohms) 202 M (210 Ohms)

TABLE 7-1. DISTRIBUTOR-TRANSMITTER, LIST OF MAJOR COMPONENTS.

REFERENCE DESIGNATION	QUANTITY	NAME OF MAJOR COMPONENT	DESIGNATION	PAGE
100 to 199	1	COVER	LXDC200	7-2
		COVER, MINIATURIZED	LXDC201	7-2
200 to 499	1	BASE	LXDB1	7-2
		BASE, MINIATURIZED	LXDB4	7-2
500 to 599	1	MOTOR	LMU3	7-6
600 to 699		MOTOR, MINIATURIZED	LMU19	7-7
700 to 1099	1	DISTRIBUTOR-TRANSMITTER	LXD1	7-8
		DISTRIBUTOR-TRANSMITTER	LXD4	7-8

SECTION 7

PARTS LIST

7-1. INTRODUCTION.

Reference designations have been assigned to identify all maintenance parts of the equipment. They are used for marking the equipment (adjacent to the part they identify) and are included on drawings, diagrams, and the parts list. The letters of a reference designation indicate the kind of part (generic group). The number differentiates between parts of the same generic group. Parts of the same first component are numbered from 101 to 199; parts of the second are numbered from 201 to 499. As in the case of the second major component, consecutive series of 100 numbers have been assigned to each major component in which there are more than 100 parts in a generic group. Stock numbers of parts used in this equipment may be obtained by referring to the Stock Number Identification Table (SNIT) published by E.S.O.

7-2. LIST OF MAJOR COMPONENTS.

Table 7-1 is arranged by groups of reference designations applicable to a major component. Thus, when the reference designation of a part is known, this table will furnish ready reference to the major component in which it is used. The table also gives the following information for each major component: (1) official nomenclature (see columns 3 and 4); (2) quantity in one equipment (column 2); and (3) location of its parts in table 7-2 (column 5).

7-3. MAINTENANCE PARTS LIST.

Table 7-2 lists all major components and their maintenance parts. The parts of each major component are grouped together. Column 1 lists the reference series of each major unit, followed by the reference designations of the various groups in alphabetical and numerical order, in groups of not more than 100 parts in each generic group. Column 2 refers to the explanatory notes that appear in paragraph 7-5.

Column 3 gives the name and describes the various parts. Complete information is given for all key parts (parts differing from any part previously listed in this table) and sub-key parts (parts identical with a key part, but appearing for the first time within a major component. The name and description are omitted for other parts, but reference is made to the key part or sub-key part for the data. The contractor (code No. 59433) part number is furnished in each key and sub-key description and, in the case of vendor parts, has been added for reference in parentheses following the manufacturer's code and part number. The manufacturer's name and address, when other than the contractor, may be found by reference to the List of Manufacturers, table 7-3. Column 4 indicates how the part is used and gives its functional location in the equipment. Column 5 indicates the figure number of the pictorial illustration on which the part is identified. The figures appear in Section 6.

7-4. LIST OF MANUFACTURERS.

Table 7-3 lists manufacturers of parts used in the equipment. The first column indicates the code number used in table 7-2 to identify manufacturers. Manufacturers are listed in numerical order of their code numbers.

7-5. NOTES.

The following provide additional information about items listed in table 7-2, as referenced in column 2 of that table.

1. Peculiar to Distributor-Transmitter TT-187/UG.
2. Peculiar to Distributor-Transmitter TT-187A/UG.

TABLE 7-2. DISTRIBUTOR-TRANSMITTER, LIST OF MAINTENANCE PARTS

CABINET

REF. DES.	NOTES	NAME AND DESCRIPTION	LOCATING FUNCTION	FIG. AND INDEX NUMBER
100 to 199	1	COVER	Enclosure for components of Distributor-Transmitter TT-187/UG	6-1
	2	COVER, MINIATURIZED	Enclosure for components of Distributor-Transmitter TT-187A/UG	6-1
A101	1	COVER: 156749BR	Encloses base and motor	6-1
A102	2	COVER: 173504BR	Encloses base and motor	6-1
A103		PANEL ASSEMBLY: 156765BR	Encloses distributor-transmitter mechanism	6-1
O101	2	PAD, BASE: 173505	Acoustical liner	6-1

BASE

REF. DES.	NOTES	NAME AND DESCRIPTION	LOCATING FUNCTION	FIG. AND INDEX NUMBER
200 to 499	1	BASE	Mounting support for distributor-transmitter and related components (TT-187/UG)	6-2 through 6-4
	2	BASE, MINIATURIZED	Mounting support for distributor-transmitter and related components (TT-187A/UG)	
A201	1	GUARD: 156756	Handle for base and guard for gear mechanism	6-2
A202		PLATE, ON-OFF: 120175	Main power switch plate	6-2
A203		BRACKET, SWITCH: 156757	Mounts S201 on A205 or A305	6-2
A204		BRACKET: 156758	Mounts TB201 and TB202 to A206 or A305 and A306	6-2
A205	1	PLATE: 156754	Mount for motor, switch and terminal boards	6-2
A206	1	PLATE: 156755	Mount for motor and drive shaft mechanism	6-2
A207	1	BAR: 156752	Supports operating mechanism on A209	6-2
A208	1	BAR: 156753	Supports operating mechanism on A209	6-2
A209	1	PLATE, BASE: 156751	Mounts and supports distributor-transmitter and motor	6-2

TABLE 7-2. DISTRIBUTOR-TRANSMITTER, LIST OF MAINTENANCE PARTS (Continued)

BASE (Continued)

REF. DES.	NOTES	NAME AND DESCRIPTION	LOCATING FUNCTION	FIG. AND INDEX NUMBER
E201		(Continued. See A300.) TERMINAL: 151626	Connects S201 to TB202	6-2
E202		INSULATOR: 151412	Insulates terminal boards TB201 and TB202	6-2
E203		STRAP, TERMINAL: 151827	Straps TB201 terminals	6-2
E204		Same as E203	Straps TB201 terminals	6-2
E205		TERMINAL: 107398	Terminal for W201	6-2
E206		TERMINAL: 82474 (Continued. See E300.)	Terminal for W201	6-2
H201		SCREW: 10-32 by 3/8 hex 151723	Retains distributor-transmitter on base	6-2
H202		WASHER, LOCK: 2669	Retains distributor-transmitter on base	6-2
H203		WASHER, FLAT: 117535	Retains distributor-transmitter on base	6-2
H204	1	SCREW: 6-40 by 1/4 hex 151630	Retains A201 on base	6-2
H205		WASHER, LOCK: 2191	Retains A201 or A301 on base	6-2
H206	1	SCREW: 1/4-32 by 11/32 hex 104124	Retains motor on A205 and A206	6-2
H207	1	WASHER, LOCK: 2322	Retains motor on A205 and A206	6-2
H208		Same as H204	Retains A203 on A205 or A305	6-2
H209		Same as H205	Retains A203 on A205 or A305	6-2
H210		SCREW: 10-32 by 5/16 hex 121575	Retains A204 on A206 or A305 and A306	6-2
H211		Same as H202	Retains A204 on A206 or A305 and A306	6-2
H212		SCREW: 6-40 by 5/16 fill 111017	Terminal screw for TB201 and TB202	6-2
H213		NUT: 6-40 hex 151416	Retains H212 on TB201 and TB202	6-2
H214		STUD: 151335	Retains E202 on TB201 and TB202 on A204.	6-2
H215		Same as H204	Retains E202 on TB201 and TB202	6-2
H216		Same as H205	Retains E202 on TB201 and TB202	6-2
H217	1	CLAMP, LOOP: Nylon, mfg. code No. 71616, part No. CPC-1953-4 (code 59433 part No. 121244)	Retains W501 and W801 to base	6-2
H218	1	SCREW: 6-40 by 1/2 hex 151632	Retains H217 or H233 on base	6-2
H219	1	Same as H205	Retains H217 or H233 on base	6-2
H220	1	WASHER, FLAT: 7002	Retains H217 or H233 on base	6-2
H221		Same as H210	Retains A205 and A206 or A305 and A306 on A207 and A208 or A307 and A308	6-2
H222		Same as H202	Retains A205 and A206 or A305 and A306 on A207 and A208 or A307 and A308	6-2
H223	1	Same as H210	Retains O202 on A205 or A206	6-2
H224		Same as H202	Retains O201 on A206 or A306	6-2
H225		WASHER, FLAT: 74032	Retains O201 on A206 or A306	6-2
H226		NUT: 8-32 hex 112626	Retains O202 on A209 or A309	6-2
H227		Same as H202	Retains O202 on A209 or A309	6-2
H228		WASHER, FLAT: 120557	Retains O202 on A209 or A309	6-2

TABLE 7-2. DISTRIBUTOR-TRANSMITTER, LIST OF MAINTENANCE PARTS (Continued)

BASE (Continued)

REF. DES.	NOTES	NAME AND DESCRIPTION	LOCATING FUNCTION	FIG. AND INDEX NUMBER
H229	1	SCREW: 8-32 by 3/8 fil 49120	Retains O203 on A209 or A309	6-2
H230		WASHER, FLAT: 44048	Retains O203 on A209 or A309	6-2
H231		WASHER, FLAT: 3438	Retains O203 on A209 or A309	6-2
H232		NUT, SPECIAL: 8-32 142665	Retains O203 on A209 or A309	6-2
H233		CLAMP, LOOP: Nylon, mfg. code No. 71616 part No. CPC-1953-6 (code 59433 part No. 121246) (Continued. See H300.)	Retains W850 to base	6-2
O201		MOUNT, VIBRATION: 157215	Isolates base from motor vibration	6-2
O202		STUD: 156764	Retains O201 on A209 or A309	6-2
O203		FOOT, MOUNTING: 99381	Supports A209 or A309	6-2
O204		WASHER, LEATHER: 74100 (Continued. See O300.)	Seals A209 or A309 at O203	6-2
S201		SWITCH, POWER: 95320	Main power switch	6-2
S202		SWITCH W/LEADS: 124396 (Continued. See S300.)	Main power switch	6-2
TB201		BOARD, TERMINAL: 151411	Upper terminal board	6-2
TB202		Same as TB201	Lower terminal board	6-2
W201		WIRE, STRAP: 156656 (Continued. See W300.)	Ground wire	6-2
A301	2	GUARD: 162201	Handle for base and guard for gear mechanism	6-3
A305	2	PLATE: 162205	Mount for motor, drive shaft mechanism and terminal boards	6-3
A306	2	PLATE: 162204	Mount for motor, switch and terminal boards	6-3
A307	2	BAR: 162202	Supports operating mechanisms on A309	6-3
A308	2	BAR: 162203	Supports operating mechanisms on A309	6-3
A309	2	PLATE, BASE: 162206	Mounts and supports distributor-transmitter and motor	6-3
A321	2	BRACKET, CONNECTOR MOUNTING: 162291 (Continued. See A400.)	Mounts P301 to A308	6-3
E311	2	CLAMP, CABLE: 165082	Retainer for power and signal leads	6-3
E312	2	KEEPER: 165083	Locks cables in E311	6-3
E313	2	TERMINAL, LUG: 151626	Terminal for W302	6-3
E314	2	SLEEVE, INSULATING: 155753	Insulates W302 at S311	6-3
E315	2	SLEEVE, INSULATING: 155754	Insulates W302 at P301	6-3
H304	2	SCREW: 6-40 by 1/4 fil 8543	Retains A301 on base	6-3
H306	2	SCREW: 10-32 by 7/16 hex 153441	Retains motor to A305 and A306	6-3
H307	2	Same as H202	Retains motor to A305 and A306	6-3
H323	2	SCREW: 10-32 by 1/4 hex 151606	Retains O202 on A305 and A306	6-3
H340	2	SCREW: 6-40 by 5/16 fil 151658	Retains E311 on A305	6-3
H341	2	Same as H205	Retains E311 on A305	6-3
H342	2	SCREW: 4-40 by 1/4 hex 152893	Retains S311 on A321	6-3
H343	2	WASHER, LOCK: 110743	Retains S311 on A321	6-3
H344	2	WASHER, FLAT: 125011	Retains S311 on A321	6-3
H345	2	SCREW, SHOULDER: 3-48 45026	Retains P301 on A321	6-3
H346	2	NUT: 3-48 hex 70073	Retains P301 on A321	6-3
H347	2	WASHER, LOCK: 153819	Retains P301 on A321	6-3
H348	2	Same as H204	Retains A321 on A308	6-3
H349	2	Same as H205	Retains A321 on A308	6-3

TABLE 7-2. DISTRIBUTOR-TRANSMITTER, LIST OF MAINTENANCE PARTS (Continued)

BASE (Continued)

REF. DES.	NOTES	NAME AND DESCRIPTION	LOCATING FUNCTION	FIG. AND INDEX NUMBER
H350	2	SCREW: 6-40 by 1/4 fil 151657	Retains O311 on A309	6-3
H351	2	NUT: 6-40 hex 3606	Retains O311 on A309	6-3
H352	2	Same as H205	Retains O311 on A309	6-3
H353	2	Same as H220	Retains O311 on A309	6-3
H354	2	WASHER, FLAT: 112080	Retains O202 on A309	6-3
O301	2	MOUNT, VIBRATION: 170863	Rear shock mount for A309	6-3
O311	2	LATCH: 162199	Retains A102 on base	6-3
P301	2	CONNECTOR, RECEPTACLE: 161595	Connects distributor-transmitter (TT-187A/UG) to base	6-3
S311	2	SWITCH, SENSITIVE: 151414	Line shunt switch	6-3
W302	2	CABLE ASSEMBLY: 162198	Connects distributor-transmitter (TT-187A/UG) to base	6-3
A401		HOUSING, BEARING: 156821	Retains O413 on base	6-4
H401		POST: 156806	Retains O401 to shaft and pinion	6-4
H402		SCREW: 6-40 by 5/16 hex 151631	Retains O404, O408 or O411 on O413	6-4
H403		Same as H205	Retains O404, O408, or O411 on O413	6-4
H404		SCREW: 6-40 by 11/32 fil 151694	Retains O412 on O413	6-4
H405		Same as H205	Retains O412 on O413	6-4
H406		SCREW: 6-40 by 3/16 hex 151722	Retains O415 on O401	6-4
H407		Same as H205	Retains O415 on O401	6-4
H408		Same as H406	Retains O414 on A401	6-4
H409		Same as H205	Retains O414 on A401	6-4
H410		Same as H306	Retains A401 on A206 or A306	6-4
H411		Same as H202	Retains A401 on A206 or A306	6-4
H412		WASHER, FLAT: 34432	Retains A401 on A206 or A306	6-4
O401		RETAINER, PINION: 156805	Retains O603, O607 or O610 to motor shaft	6-4
O403		GEAR, PINION: 18 tooth 156627	Drives O404	6-4
O404		GEAR, HELICAL: 88 tooth 156626	Drives O412 (60 w.p.m.)	6-4
O405		GEAR SET: 156658	For 60 w.p.m. operation	6-4
O406		GEAR SET: 156728	For 75 w.p.m. operation	6-4
O407		GEAR, PINION: 24 tooth 156725	Drives O408	6-4
O408		GEAR, HELICAL: 94 tooth 156726	Drives O412 (75 w.p.m.)	6-4
O409		GEAR SET: 156659	For 100 w.p.m. operation	6-4
O410		GEAR, PINION: 24 tooth 156629	Drives O411	6-4
O411		GEAR, HELICAL: 72 tooth 156628	Drives O412 (100 w.p.m.)	6-4
O412		GEAR, HELICAL: 20 tooth 161246	Drives distributor-transmitter shaft	6-4
O413		SHAFT AND BEARING: 156819	Drives distributor-transmitter through O1002	6-4
O414		CLAMP: 158788	Retains O413 in A401	6-4
O415		RING, RETAINER: 155551	Retains O413 in A401	6-4

TABLE 7-2. DISTRIBUTOR-TRANSMITTER, LIST OF MAINTENANCE PARTS (Continued)

MOTOR DISTRIBUTOR-TRANSMITTER (TT-187/UG)

REF. DES.	NOTES	NAME AND DESCRIPTION	LOCATING FUNCTION	FIG. AND INDEX NUMBER
500 to 599	1	MOTOR	Power supply for Distributor-Transmitter TT-187/UG	6-5
A501	1	BRACKET ASSEMBLY: 150976	Support for motor	6-5
A502	1	PLATE, MOUNTING: 151920	Support for C501, K501 and S501	6-5
B501	1	MOTOR, AC: 151795	Operates distributor transmitter	6-5
B502	1	FAN: 123769	Cools motor	6-5
C501	1	CAPACITOR, FIXED, ELECTROLYTIC: 125 V a.c. working, max. working temperature 50° C, insulated aluminum can, approx 3-3/16 in. lg by 1-1/16 in. diam, mfg code No. 74861 part No. AX7 (code 59433 part No. 122245)	Motor starting capacitor	6-5
E501	1	ROTOR, MOTOR: 128874	Operates B501 and O403, O407, or O410	6-5
E502	1	INSULATOR, PLATE: 151924	Insulates K501 from A502	6-5
E503	1	WASHER, FLAT: 87334	Insulates S501 from mounting hardware	6-5
E504	1	WASHER, FLAT: 153049	Insulating washer for H503	6-5
E505	1	TERMINAL: 151626. Same as E201	Terminal for W501	6-5
H501	1	WASHER, EXTRUDED: 122211	Pull washer for O501	6-5
H502	1	WASHER, FLAT: 152297	Support for O503	6-5
H503	1	SCREW, MACHINE: 8-32 fil 122229	Retains O502 on O501	6-5
H505	1	NUT, HEX: 2263	Retains O502 on O501	6-5
H506	1	SCREW, MACHINE: 6-40 fil 1179	Retains B502 on E501	6-5
H507	1	WASHER, LOCK: 2191. Same as H205	Retains B502 on E501	6-5
H508	1	STRAP, MOUNTING: 151620	Clamps B501 on A501	6-5
H509	1	SCREW, MACHINE: 6-32 rd hd 151621	Applies tension to H508	6-5
H510	1	NUT: 6-32 square 151622	Retains H509 on H508	6-5
H511	1	CLAMP: 151925	Retains K501 on A502	6-5
H512	1	SCREW, MACHINE: 4-40 by 1/4 fil 151637	Retains H511 on A502	6-5
H513	1	WASHER, LOCK: 3640	Retains H511 on A502	6-5
H514	1	CLAMP: 151922	Retains C501 on A502	6-5
H515	1	Same as H512	Retains H514 on A502	6-5
H516	1	Same as H513	Retains H514 on A502	6-5
H517	1	NUT: 4-40 hex 151926	Spaces S501 from A502	6-5
H518	1	SCREW, MACHINE: 4-40 by 3/8 fil 151686	Retains S501 on H517	6-5
H519	1	Same as H513	Retains S501 on H517	6-5
H520	1	WASHER, FLAT: 125011. Same as H344	Retains S501 on H517	6-5
H521	1	Same as H512	Retains H517 on A502	6-5
H522	1	Same as H513	Retains H517 on A502	6-5
H523	1	SCREW, MACHINE: 6-40 fil 151692	Retains A502 on A501	6-5
H524	1	Same as H507	Retains A502 on A501	6-5
H525	1	WASHER, FLAT: 7002. Same as H220	Retains A502 on A501	6-5
H526	1	SCREW, MACHINE: 6-40 fil 151346	Holds pinion gear to E501	6-5
H527	1	Same as H507	Holds pinion gear to E501	6-5
K501	1	RELAY, MOTOR STARTING: 151923	Starting relay for motor	6-5
O501	1	STATOR, MOTOR: 122251	Operates E501	6-5
O502	1	END-BELL: 122252	Mounts and encloses E501 in O501	6-5

SEE change T-1 FOR REF. TO governed Motors

TABLE 7-2. DISTRIBUTOR-TRANSMITTER, LIST OF MAINTENANCE PARTS (Continued)

MOTOR (DISTRIBUTOR-TRANSMITTER TT-187/UG) (Continued)

REF. DES.	NOTES	NAME AND DESCRIPTION	LOCATING FUNCTION	FIG. AND INDEX NUMBER
O503	1	SPRING: 71999	Applies pressure to E501	6-5
O504	1	BEARING, BALL: 122201	Bearings for E501 in O502	6-5
O505	1	BALL, OILER: 122220	Lubricator for E501 shaft (part of O502)	6-5
O506	1	MOUNT, VIBRATION: 153030	Vibration dampener for E502 (part of O502)	6-5
S501	1	SWITCH, THERMOSTATIC, SPST: 122249	Overload switch prevents over-heating	6-5
W501	1	CABLE ASSEMBLY: 151927	Connects motor to TB201	6-5
W502	1	STRAP, WIRE: 96264	Connects C501 to K501	6-5

MOTOR (DISTRIBUTOR-TRANSMITTER TT-187A/UG)

REF. DES.	NOTES	NAME AND DESCRIPTION	LOCATING FUNCTION	FIG. AND INDEX NUMBER
600 to 699	2	MOTOR	Power supply for Distributor-Transmitter Set TT-187A/UG	6-6
A601	2	BRACKET: 142589	Support for motor	6-6
B601	2	MOTOR, AC: 161984	Operates distributor-transmitter	6-6
C601	2	CAPACITOR, FIXED: 162072	Starting capacitor for motor	6-6
E601	2	WASHER, FLAT: 87334. Same as E503	Insulates S601 from mounting hardware	6-6
E602	2	INSULATOR: 162196	Insulates K601 from A601 and C601	6-6
E603	2	TERMINAL, LUG: 151626. Same as E313	Terminal for W601	6-6
E605	2	SLEEVE, INSULATING: 155755	Insulates W601	6-6
E606	2	ROTOR, MOTOR: 162465	Operates O403, O407 or O410 and B601	6-6
H601	2	SCREW: 4-40 by 3/8 fil 151686. Same as H518	Retains S601 on H604	6-6
H602	2	WASHER, LOCK: 3640. Same as H513	Retains S601 on H604	6-6
H603	2	WASHER, FLAT: 125011. Same as H344	Retains S601 on H604	6-6
H604	2	NUT: 4-40 hex 151926 Same as H517	Separates S601 from A601	6-6
H605	2	SCREW: 4-40 by 1/4 fil 151637. Same as H512	Retains H604 and H621 on A601	6-6
H606	2	Same as H602	Retains H604 and H621 on A601	6-6
H607	2	Same as H605	Retains H622 on A601	6-6
H608	2	Same as H602	Retains H622 on A601	6-6
H609	2	STRAP, MOUNTING: 151620. Same as H508	Clamps B601 on A601	6-6
H610	2	SCREW: 6-32 by 3/4 rd hd 151621. Same as H509	Applies tension to H609	6-6
H611	2	NUT: 6-32 square 151622. Same as H510	Retains H610 on H609	6-6
H612	2	SCREW: 6-40 by 5/8 hex 153839	Clamps O601 on B601	6-6
H613	2	NUT: 6-40 hex 152426	Retains H612 on O601	6-6
H614	2	WASHER, FLAT: 7002. Same as H220	Retains H612 on O601	6-6
H615	2	WASHER, SHIM: 164892	Spacer for E606	6-6
H616	2	WASHER, FLAT: 164894	Spacer for E606	6-6
H617	2	WASHER, FLAT: 164891	Spacer for E606	6-6
H618	2	BOLT: 6-32 by 3-1/2 fil 162482	Retains O605 and O606 on O602	6-6
H619	2	NUT: 6-32 hex 172902	Retains H618 on O602	6-6
H620	2	SPACER: 3949	Spaces H612 and H613 from O601	6-6
H621	2	CLAMP: 151922. Same as H514	Retains C601 on A601	6-6
H622	2	CLAMP: 151925. Same as H511	Retains K601 on A601	6-6
K601	2	RELAY, MOTOR STARTING: 173425	Starting relay for motor	6-6

TABLE 7-2. DISTRIBUTOR-TRANSMITTER, LIST OF MAINTENANCE PARTS (Continued)

MOTOR (DISTRIBUTOR-TRANSMITTER TT-187A/UG) (Continued)

REF. DES.	NOTES	NAME AND DESCRIPTION	LOCATING FUNCTION	FIG. AND INDEX NUMBER
O601	2	BRACKET: 164962	Cover and vent duct for B601	6-6
O602	2	STATOR: 162464	Operates E606	6-6
O603	2	END-BELL: 162466	Mounts and encloses E606 in O602	6-6
O604	2	WASHER, SPRING: 162469	Applies tension to E606	6-6
O605	2	END-BELL: 162467	Mounts and encloses E606 in O602	6-6
O606	2	MOUNT, VIBRATION: 153030. Same as O506	Vibration dampener for E502 (part of O603 and O605)	6-6
O607	2	BEARING, BALL: 164890	Bearing for E606 in O603 and O605 (part of E606)	6-6
O608	2	COLLAR, THRUST: 164893	Thrust bearing for E606 (part of E606)	6-6
S601	2	SWITCH, THERMOSTATIC: 174471	Overload switch to prevent overheating	6-6
W601	2	CABLE ASSEMBLY: 161099	Connects motor to TB201	6-6
W602	2	STRAP, WIRE: 96264R. Same as W502	Connects C601 and K601	6-6

DISTRIBUTOR-TRANSMITTER

REF. DES.	NOTES	NAME AND DESCRIPTION	LOCATING FUNCTION	FIG. AND INDEX NUMBER
700 to 1099		DISTRIBUTOR-TRANSMITTER	Transmits teletype signal from punched tape	6-7 through 6-15
A701		PLATE, COVER: 156608	Cover plate for distributor-transmitter	6-7
A702		BRACKET: 156780	Supports O702 through O704	6-7
A703		BRACKET: 156556	Supports A704 on A806 and A905	6-7
A704		PLATE, TOP: 156567	Top plate and cover for feed mechanism	6-7
A751		Same as A703	Supports A756	6-8
A752		PLATE: 174349	Guides O900	6-8
A753		GUIDE, LEFT: 156811	Guides tape	6-8
A754		GUIDE, RIGHT: 156551	Guides tape	6-8
A755		BRACKET: 164471	Supports O755, anchors O761 and pivots O762 and O763	6-8
A756		PLATE, TAPE GUIDE: 156557 (Continued. See A800)	Mounts A753, A754 and A755	6-8
H701		NUT: 6-40 hex 3598	Retains O701 on A701	6-7
H702		WASHER, LOCK: 2191. Same as H205	Retains O701 on A701	6-7
H703		WASHER, FLAT: 7002. Same as H220	Retains O701 on A701	6-7
H704		Same as H701	Retains A702 on A701	6-7
H705		Same as H702	Retains A702 on A701	6-7
H706		WASHER, FLAT: 93587	Retains A702 on A701	6-7
H707		SCREW: 4-40 by 1/4 hex 152893. Same as H342	Retains A703 on A806 and A905	6-7

TABLE 7-2. DISTRIBUTOR-TRANSMITTER, LIST OF MAINTENANCE PARTS (Continued)

DISTRIBUTOR-TRANSMITTER(Continued)

REF. DES.	NOTES	NAME AND DESCRIPTION	LOCATING FUNCTION	FIG. AND INDEX NUMBER
H708		WASHER, LOCK: 110743. Same as H343	Retains A703 on A806 and A905	6-7
H709		WASHER, FLAT: 125011. Same as H344	Retains A703 on A806 and A905	6-7
H710		NUT: 4-40 hex 3599	Retains A704 on A703	6-7
H711		Same as H708	Retains A704 on A703	6-7
H712		Same as H709	Retains A704 on A703	6-7
H751		Same as H707	Retains A751 on A806 and A905	6-8
H752		Same as H708	Retains A751 on A806 and A905	6-8
H753		Same as H709	Retains A751 on A806 and A905	6-8
H754		Same as H710	Retains A756 on A751	6-8
H755		Same as H708	Retains A756 on A751	6-8
H756		Same as H709	Retains A756 on A751	6-8
H757		NUT: 4-40 hex 151880	Retains A752, A753 and A754 on A756	6-8
H758		Same as H708	Retains A752, A753 and A754 on A756	6-8
H759		WASHER, FLAT: 119401	Retains A752, A753 and A754 on A756	6-8
H760		RING, RETAINER: Steel, mfg. code No. 79136, part No. 5133-18 (code 59433 part No. 119652)	Retains O752 on A756	6-8
H761		SCREW: 4-40 by 3/16 hex 151152	Retains O755 on A755	6-8
H762		Same as H708	Retains O755 on A755	6-8
H763		Same as H709	Retains O755 on A755	6-8
H764		RING, RETAINER: Steel, mfg. code No. 79136, part No. 5133-15 (code 59433 part No. 119651)	Retains O752 on A753	6-8
H765		Same as H710	Retains O753 and O754 on O755	6-8
H766		Same as H708	Retains O753 and O754 on O755	6-8
H767		Same as H757	Retains O757 on O760	6-8
H768		Same as H708	Retains O757 on O760	6-8
H769		RING, RETAINER: Steel, mfg. code No. 79136 part No. 5133-6 (code 59433 part No. 119647)	Retains O758 and O759 on O760	6-8
H770		RING, RETAINER: Steel, mfg. code No. 79136, part No. 5133-12 (code 59433 part No. 119649)	Retains O762 on A755	6-8
H771		Same as H710	Retains A755 on A756	6-8
H772		Same as H708	Retains A755 on A756	6-8
H773		Same as H709	Retains A755 on A756	6-8
O701		(Continued. See H800.) PLATE: 156609	Positions A701	6-7
O702		PLUNGER: 156779	Retains A701 in position	6-7
O703		SPRING: 74987	Applies tension to O702	6-7
O704		Rod: 156778	Mounts O702 and O703 on A702	6-7

TABLE 7-2. DISTRIBUTOR-TRANSMITTER, LIST OF MAINTENANCE PARTS (Continued)

DISTRIBUTOR-TRANSMITTER(Continued)

REF. DES.	NOTES	NAME AND DESCRIPTION	LOCATING FUNCTION	FIG. AND INDEX NUMBER
O751		SPRING: 41382	Applies tension to O760	6-8
O752		PLUNGER, ALUMINUM: 156555	Operates O753	6-8
O753		BAIL: 164468	Latches O760	6-8
O754		POST, ECCENTRIC: 164467	Adjusts and supports O753	6-8
O755		BRACKET: 164470	Supports O754 and pivots O760	6-8
O756		WASHER, FELT: 156558	Lubricates O755	6-8
O757		POST: 164469	Anchors O751	6-8
O758		SHAFT: 156561	Pivots O759	6-8
O759		BAIL: 156560	Senses taut or tangled tape input	6-8
O760		LID, TAPE: 156549	Guides tape	6-8
O761		SPRING: 104751	Applies tension to O762	6-8
O762		BAIL: 156673	Retains O763 in selected position	6-8
O763		LEVER, START-STOP: 156647	Distributor-transmitter control switch	6-8
O764		SPRING, TAPE LID LATCH: 161440 (Continued. See O800.)	Applies tension to O753	6-8
A800		BRACKET: 160608	Supports E801 through E809	6-9
A802		PLATE: 156599	Mounts distributor-transmitter to base	6-9
A803		POST: 156598	Supports A802 and O811	6-9
A804		PLATE: 160597	Retains A805 and O813 on O815	6-9
A805		STIFFENER: 160598	Holds O813 against O1013	6-9
A806		PLATE: 156597	Supports distributor-transmitter mechanism	6-9
A850		BRACKET: 160621	Supports E853 through E855	6-10
A852		BRACKET: 156531	Supports A850, A851, A853 and L850	6-10
A853		PLATE: 156662	Insulates L3650 terminals	6-10
A854		PLATE: 154173	Relieves stress on E3650	6-10
A875		PLATE: 160616	Supports center plate mechanism	6-11
E800		(Continued. See A900.) BUSHING, INSULATOR: 86959	Insulated H803 from E802, E803, E806 and E807	6-9
E801		INSULATOR: 82548	Insulates E802 from A800	6-9
E802		TERMINAL: 160593	Terminal for E803	6-9
E803		CONTACT ASSY, SPRING: 160399	Completes circuit when E807 is closed	6-9
E804		Same as E801	Insulates E803 from E806	6-9
E805		INSULATOR: 82547	Insulates E803 from E806 and spaces E803 from E807	6-9
E806		Same as E802	Terminal for E807	6-9
E807		CONTACT ASSY, SPRING: 160398	Swinger for S800	6-9
E808		Same as E801	Insulates E807 from E809	6-9
E809		PLATE, RETAINING: 41732	Retains E801 through E808 on A3600	6-9
E850		TERMINAL: 131099	Terminal for W850 or W851	6-10
E851	1	TERMINAL: 151626. Same as E201	Termination for W851	6-10

TABLE 7-2. DISTRIBUTOR-TRANSMITTER, LIST OF MAINTENANCE PARTS (Continued)

DISTRIBUTOR-TRANSMITTER(Continued)

REF. DES.	NOTES	NAME AND DESCRIPTION	LOCATING FUNCTION	FIG. AND INDEX NUMBER
E852		SLEEVE, INSULATING: 155750	Insulator for W850	6-10
E853		SHIELD: 152458	Insulator guard for terminals of L850 and W850	6-10
E854		GUIDE: 160622	Insulator guard for terminals of L850 and W850	6-10
E855		GUIDE: 160623	Insulator guard for terminals of L850 and W850	6-10
E856		ARMATURE: 156537	Operates O855	6-10
E857		SLEEVE, INSULATING: 155754. Same as E315 (Continued. See E900.)	Insulator for W851	6-10
H800		Same as H707	Retains S800 on A806	6-9
H801		Same as H708	Retains S800 on A806	6-9
H802		WASHER, FLAT: 125802	Retains S800 on A806	6-9
H803		SCREW: 4-40 by 9/16 fil 151733	Retains E801 through E809 on A800	6-9
H804		Same as H708	Retains E801 through E809 on A800	6-9
H805		Same as H701	Retains O802 on A806	6-9
H806		Same as H702	Retains O802 on A806	6-9
H807		Same as H760	Retains O803 through O806 on O802	6-9
H808		Same as H710	Retains O808 on A806	6-9
H809		Same as H708	Retains O808 on A806	6-9
H810		SCREW: 6-40 by 3/16 hex 151722. Same as H406	Retains O809 on A806	6-9
H811		Same as H702	Retains O809 on A806	6-9
H812		SCREW: 6-40 by 1/4 hex 151630. Same as H204	Retains O810 on A806	6-9
H813		Same as H702	Retains O810 on A806	6-9
H814		Same as H703	Retains O810 on A806	6-9
H815		NUT: 10-32 hex 112626. Same as H226	Retains A803 on A806	6-9
H816		WASHER, LOCK: 2669. Same as H202	Retains A803 on A806	6-9
H817		SCREW: 6-40 by 5/16 hex 151631. Same as H402	Retains A802 on A803	6-9
H818		Same as H702	Retains A802 on A803	6-9
H819		SCREW: 6-40 by 1/2 hex 151632. Same as H218	Retains H822 on O811 on A803	6-9
H820		Same as H702	Retains H822 and O811 on A803	6-9
H821		Same as H703	Retains H822 and O811 on A803	6-9
H822		CLAMP, LOOP: Nylon, mfg. code No. 71616, part No. CPC-1953-4 (code 59433 part No. 121244). Same as H217	Retains W851 on O815	6-9
H823		Same as H817	Retains A804, A805 and O813 on O815	6-9
H824		SCREW: 6-40 fil 151692. Same as H523	Retains A804, A805 and A813 on O815	6-9
H825		WASHER, LOCK: 3649	Retains A804, A805 and A813 on O815	6-9
H826		Same as H812	Retains O816 on A806	6-9

TABLE 7-2. DISTRIBUTOR-TRANSMITTER, LIST OF MAINTENANCE PARTS (Continued)

DISTRIBUTOR-TRANSMITTER(Continued)

REF. DES.	NOTES	NAME AND DESCRIPTION	LOCATING FUNCTION	FIG. AND INDEX NUMBER
H827		Same as H706	Retains O816 on A806	6-9
H828		Same as H702	Retains O816 on A808	6-9
H829		Same as H817	Retains H822 on A803	6-9
H850		Same as H812	Retains A852 on A806	6-10
H851		Same as H702	Retains A852 on A806	6-10
H852		WASHER, FLAT: 125015	Retains A852 on A806	6-10
H853		Same as H812	Retains A850 on A852	6-10
H854		Same as H702	Retains A850 on A852	6-10
H855		Same as H703	Retains A850 on A852	6-10
H856		Same as H770	Retains O853 on A851	6-10
H857		Same as H770	Retains O853 on A851	6-10
H858		SCREW: 4-40 by 5/32 fil 151073	Retains E856 on O855	6-10
H859		WASHER, LOCK: 3640. Same as H513	Retains E856 on O855	6-10
H860		Same as H707	Retains A851 on A852	6-10
H861		WASHER, LOCK: 93984	Retains A851 on A852	6-10
H862		Same as H709	Retains A851 on A852	6-10
H863		Same as H710	Retains O856 on A852	6-10
H864		Same as H708	Retains O856 on A852	6-10
H865		SCREW: 6-40 by 13/32 hex 156632	Retains A853 and L850 on A852	6-10
H866		Same as H702	Retains A853 and L850 on A852	6-10
H867		SCREW: 4-40 by 3/16 fil 81778	Retains W850 or W851 terminals to L850	6-10
H868		WASHER, FLAT: 2438	Retains W850 or W851 terminals to L850	6-10
H875		Same as H812	Retains O875 on A806	6-11
H876		Same as H702	Retains O875 on A806	6-11
H877		Same as H702	Retains O876 on A875	6-11
H879		Same as H701	Retains O877 on A875	6-11
H880		Same as H702	Retains O877 on A875	6-11
H881		Same as H769	Retains O879 on O880	6-11
H882		Same as H708	Retains O881 on A875	6-11
H883		NUT: 6-40 hex 3606. Same as H351	Retains O884 and O885 on A875	6-11
H884		WASHER, LOCK: 124177	Retains O884 and O885 on A875	6-11
H885		RING, RETAINER: Steel, mfg. code No. 79136, part No. 5133-14 (code 59433 part No. 119650)	Retains O888 and O886 on O885	6-11
H886		Same as H885	Retains O888 and O886 on O885	6-11
H887		Same as H761	Retains O887 on O8888	6-11
H888		Same as H708	Retains O887 on O888	6-11
H889		Same as H709	Retains O887 on O888	6-11
H890		POST, SPRING: 156574 (Continued. See H900.)	Anchors O878	6-11
J850 or P850 L850	2	CONNECTOR, PLUG: 161594 COIL, MAGNET: 256M	Connects distributor-transmitter to base Attracts E856	6-10 6-10

TABLE 7-2. DISTRIBUTOR-TRANSMITTER, LIST OF MAINTENANCE PARTS (Continued)

DISTRIBUTOR-TRANSMITTER(Continued)

REF. DES.	NOTES	NAME AND DESCRIPTION	LOCATING FUNCTION	FIG. AND INDEX NUMBER
O800		SPRING: 151395	Applies tension to O804	6-9
O801		SPRING: 2836	Applies tension to O805	6-9
O802		STUD: 156581	Pivot for O804 through O806	6-9
O803		WASHER, FELT: 156591	Lubricates O802	6-9
O804		LEVER, TRIP: 156594	Releases O808	6-9
O805		LEVER, LATCH: 156595	Latches O811	6-9
O806		BAIL: 156596	Operates O804	6-9
O807		WASHER, FELT: 156633	Lubricates O806	6-9
O808		POST, SPRING: 156589	Anchors O801	6-9
O809		CLAMP, BEARING: 156588	Clamps O800 to A806	6-9
O810		GUARD: 160601	Cover for clutch mechanism	6-9
O811		RESERVOIR ASSY: 160615	Lubricates O813	6-9
O812		WASHER, LEATHER: 85318	Oil seal for A804	6-9
O813		WICK, LEATHER: 160599	Lubricates O813	6-9
O814		WICK, OIL: 161439	Lubricates O966	6-9
O815		RESERVOIR, OIL: 160600	Reservoir for O811	6-9
O816		NUT, SPECIAL: 156782	Retains O702	6-9
O850		HINGE, MOUNTING: 158757	Supports O853	6-10
O851		GROMMET, RUBBER: 154156	Protects W850 or W851 at A1027	6-10
O852		SPRING: 152871	Applies tension to O855	6-10
O853		SHAFT: 156817	Pivot for O855	6-10
O854		WASHER, FELT: 156539	Lubricates O853	6-10
O855		BAIL: 156534	Operates O907	6-10
O856		SCREW, ECCENTRIC: 4-40, 156533	Limits travel of E856	6-10
O857		CORE: 156532	Attracts E856	6-10
O858		WASHER, SPRING TENSION: Steel, mfg. code No. 78189, part No. 3502-20 (code 59433 part No. 121125)	Applies pressure to L850	6-10
O875		POST: 156622	Spaces A875 from A806	6-11
O876		SCREW, SPRING POST: 156668	Anchors O881	6-11
O877		SCREW, ECCENTRIC: 6-40, 156575	Pivot for O880	6-11
O878		WASHER, FELT: 156576	Lubricates O877	6-11
O879		ROLLER: 156577	Bearing surface for O880	6-11
O880		BAIL, RATCHET DETENT LEVER: 156578	Detents O3700 sprocket	6-11
O881		SPRING: 76422	Applies tension to O880	6-11
O882		SPRING: 45024	Applies tension to O883 and O888	6-11
O883		ARM: 160613	Operates O828 (marking)	6-11
O884		POST: 160604	Pivot for O883	6-11
O885		Same as O884	Pivot for O886, O887 and O888	6-11
O886		BAIL: 160607	Operates S800 and O951	6-11
O887		ARM: 160602	Operates O828 (spacing)	6-11
O888		ARM: 160606	Operates O759, O883 and O887	6-11
S800		(Continued. See O900.) CONTACT ASSY, ELECTRICAL: 160639	Start-Stop and tight tape switch	6-9
W850	1	(Continued. See S900.) CABLE ASSY: 159672	Connects distributor-transmitter to base	6-10

TABLE 7-2. DISTRIBUTOR-TRANSMITTER, LIST OF MAINTENANCE PARTS (Continued)

DISTRIBUTOR-TRANSMITTER(Continued)

REF. DES.	NOTES	NAME AND DESCRIPTION	LOCATING FUNCTION	FIG. AND INDEX NUMBER
W851	2	CABLE ASSY: 161591	Connects distributor-transmitter to J850	6-10
A900	1	PLATE: 156602	Mounts distributor-transmitter to base	6-12
A901		Same as A803	Supports A900 and spaces A905 from A806	6-12
A902		GUIDE, TRANSFER LEVER: 156638	Guide for O910	6-12
A903		GUIDE, TRANSFER LEVER: 156621	Guide for O910	6-12
A904		BRACKET: 156625	Anchors O912 and O913	6-12
A905		PLATE: 156649	Supports distributor-transmitter mechanism	6-12
A910		PLATE: 161592	Mounts distributor-transmitter to base and J850 to distributor transmitter	6-12
A950		PLATE: 156832	Retains O1012 in A905	6-13
A951		PLATE, SCREW: 76275	Retains S950, O967, O968 and O975 to A905	6-13
A952		BRACKET, CONTACT: 160629 (Continued. See A1000.)	Supports E950 through E957	6-13
E901	2	SCREW, INSULATING: 162249	Operates S311	6-12
E950		INSULATOR: 160626	Insulates E951 from H978	6-13
E951		CONTACT: 160631	Contact for S950	6-13
E952		Same as E950	Insulates E951 from E953	6-13
E953		CONTACT: 160628	Swinger for S950	6-13
E954		Same as E950	Insulates E953 from E955	6-13
E955		CONTACT: 160630	Contact for S950	6-13
E956		Same as E950	Insulates E955 from A952	6-13
E957		BUSHING, INSULATING: 160627	Insulates H976 from E951, E953 and E955	6-13
		(Continued. See E1000.)		
H900		Same as H815	Retains A901 on A905	6-12
H901		Same as H816	Retains A901 on A905	6-12
H902		Same as H817	Retains A900 on A901	6-12
H903		Same as H702	Retains A900 on A901	6-12
H904		Same as H701	Retains O902 on A905	6-12
H905		Same as H702	Retains O902 on A905	6-12
H906		Same as H810	Retains A902 on A905	6-12
H907		Same as H702	Retains A902 on A905	6-12
H908		Same as H701	Retains O904 on A905	6-12
H909		Same as H702	Retains O904 on A905	6-12
H910		Same as H824	Retains A903 on A905	6-12
H911		Same as H702	Retains A903 on A905	6-12
H912		Same as H701	Retains O909 on A875	6-12
H913		Same as H702	Retains O909 on A875	6-12
H914		Same as H701	Retains O909 on A905	6-12
H915		Same as H702	Retains O909 on A905	6-12
H916		Same as H810	Retains A904 on A905	6-12
H917		Same as H702	Retains A904 on A905	6-12
H918		Same as H701	Retains O917 on A875	6-12
H919		Same as H702	Retains O917 on A875	6-12
H920		Same as H701	Retains O917 on A905	6-12

TABLE 7-2. DISTRIBUTOR-TRANSMITTER, LIST OF MAINTENANCE PARTS (Continued)

DISTRIBUTOR-TRANSMITTER(Continued)

REF. DES.	NOTES	NAME AND DESCRIPTION	LOCATING FUNCTION	FIG. AND INDEX NUMBER
H921		Same as H702	Retains O917 on A905	6-12
H922		Same as H701	Retains O919 on O926	6-12
H923		Same as H702	Retains O919 on O926	6-12
H924		Same as H701	Retains O921 on O926	6-12
H925		Same as H702	Retains O921 on O926	6-12
H926		Same as H701	Retains O926 on O923	6-12
H927		Same as H702	Retains O926 on O923	6-12
H928		Same as H701	Retains O925 on A905	6-12
H929		Same as H702	Retains O925 on A905	6-12
H930		Same as H760	Retains O926 and O924 on O925	6-12
H931		WASHER, FLAT: 102994	Spaces O925 from O926	6-12
H935	2	WASHER, LOCK: 153819. Same as H347	Retains J850 on A910	6-12
H936	2	NUT: 3-48 hex 70073. Same as H346	Retains J850 on A910	6-12
H937	2	NUT: 6-32 hex 125229	Adjusts E901 to operate S311	6-12
H950		Same as H812	Retains O956 on A905	6-13
H951		Same as H702	Retains O956 on A905	6-13
H952		Same as H703	Retains O956 on A905	6-13
H953		Same as H810	Retains O951 on O952	6-13
H954		Same as H702	Retains O951 on O952	6-13
H955		Same as H703	Retains O951 on O952	6-13
H956		RING, RETAINER: Steel, mfg. code No. 79136, part No. 5133-21 (code 59433 part No. 128357)	Retains O952 on O956	6-13
H957		SCREW: 4-40 by 11/64 hex 151737	Retains O955 on O956	6-13
H958		Same as H859	Retains O955 on O956	6-13
H959		Same as H709	Retains O955 on O956	6-13
H960		Same as H812	Retains O960 on A905	6-13
H961		Same as H702	Retains O960 on A905	6-13
H962		WASHER, FLAT: 91904	Retains O960 on A905	6-13
H963		RING, RETAINER: Steel, mfg. code No. 79136, part No. 5133-9 (code 59433 part No. 119648)	Retains O958 and O959 on O960	6-13
H964		Same as H701	Retains O963 on A905	6-13
H965		Same as H702	Retains O963 on A905	6-13
H966		WASHER, FLAT: 156623	Retains O963 on A905	6-13
H967		Same as H764	Retains O961 on O963	6-13
H968		WASHER, FLAT: 156509	Spaces O961 from shoulder of O963	6-13
H969		Same as H858	Retains O964 on A905	6-13
H970		Same as H708	Retains O964 on A905	6-13
H971		SCREW: 6-40 by 7/32 fil 156501	Retains O965 and O950 on A905	6-13
H972		Same as H702	Retains O965 and O950 on A905	6-13
H973		Same as H819	Retains S950, O967, O968 and H975 on A905	6-13
H974		Same as H702	Retains S950, O967, O968 and H975 on A905	6-13
H975		WASHER, FLAT: 76461	Spaces A951 from O968	6-13

TABLE 7-2. DISTRIBUTOR-TRANSMITTER, LIST OF MAINTENANCE PARTS (Continued)

DISTRIBUTOR- TRANSMITTER(Continued)

REF. DES.	NOTES	NAME AND DESCRIPTION	LOCATING FUNCTION	FIG. AND INDEX NUMBER
H976		SCREW: 2-56 by 1/2 fil 1222	Retains H978 and E950 through E957 on A952	6-13
H977		WASHER, LOCK: 93118	Retains H978 and E950 through E957 on A952	6-13
H978		PLATE, CLAMP: 138034	Retains E950 through E957 on A952	6-13
H979		Same as H812	Retains O969 on A905	6-13
H980		Same as H702	Retains O969 on A905	6-13
H981		Same as H706	Retains O969 on A905	6-13
H982		Same as H816	Retains A803 on A905	6-13
H983		Same as H815	Retains A803 on A905	6-13
		(Continued. See H1000.)		
O900		WHEEL, FEED: 156636	Moves tape across O915	6-12
O901		WASHER, FELT: 115221	Lubricates O902	6-12
O902		POST: 156618	Shaft for O900	6-12
O903		SPRING: 155494	Operates O910	6-12
O904		POST: 156624	Supports O910	6-12
O905		SPRING: 82861	Applies tension to O908	6-12
O906		SPRING: 7603	Applies tension to O907	6-12
O907		LATCH: 156590	Locks O926 in down position	6-12
O908		BAIL: 156837	Locks O910	6-12
O909		POST, GUIDE: 156640	Guide for O910	6-12
O910		LEVER, TRANSFER: 154040	Operates O961	6-12
O912		Same as O906	Applies tension to O916	6-12
O913		SPRING: 154349	Applies tension to O915	6-12
O914		WASHER, FELT: 156631	Lubricates O926	6-12
O915		FINGER, SENSING: 156641	Sense code perforations in tape, operates O910	6-12
O916		PIN, SENSING: 160640	Operates S950	6-12
O917		POST, GUIDE: 156639	Guides O915 and O916	6-12
O918		SCREW, ECCENTRIC: 156521	Guides O919	6-12
O919		ARM: 156520	Operates O926	6-12
O920		SPRING: 70388	Applies tension to O922	6-12
O921		Same as O918	Pivot for O922	6-12
O922		PAWL: 156522	Operates O900	6-12
O923		STUD, ECCENTRIC: 156523	Operates O806	6-12
O924		WASHER, FELT: 156519	Lubricates O925	6-12
O925		POST: 156518	Pivot for O926	6-12
O926		BAIL, OPERATING: 156524	Operates sensing and transfer mechanisms	6-12
O950		SPRING: 31636	Applies tension to O952	6-13
O951		ARM, EXTENSION: 159293	Operates O952	6-13
O952		BAIL: 159292	Operates O954	6-13
O953		SPRING, TORSION: 159298	Applies tension to O952 and O954	6-13
O954		BAIL: 159291	Operates O916	6-13
O955		ARM, STOP: 159297	Limits downward movement of O916	6-13
O956		BRACKET: 159295	Pivot for O951 through O954, support for O955 and anchor for O950	6-13

TABLE 7-2. DISTRIBUTOR-TRANSMITTER, LIST OF MAINTENANCE PARTS (Continued)

DISTRIBUTOR-TRANSMITTER(Continued)				
REF. DES.	NOTES	NAME AND DESCRIPTION	LOCATING FUNCTION	FIG. AND INDEX NUMBER
O957		SPRING: 91120	Applies tension to O958	6-13
O958		LATCH: 156516	Latches O961	6-13
O959		WASHER, FELT: 156515	Lubricates O958	6-13
O960		PLATE: 156514	Pivot for O958	6-13
O961		BAIL, TRANSFER: 156511	Holds O962 and operates O1028	6-13
O962		WICK, LEATHER: 159312	Lubricates O910	6-13
O963		POST: 156510	Pivot for O961	6-13
O964		CLIP: 160625	Positions O919 on O1013 under spring tension	6-13
O965		CLAMP: 156831	Bearing O1012 retainer	6-13
O966		SPRING: 160596	Applies tension to O916	6-13
O967		BUSHING, SHOULDER: 101998	Pivot for O968	6-13
O968		BRACKET, SPRING: 160638	Anchors O966	6-13
O969		Same as O816	Retains O702	6-13
		(Continued. See O1000.)		
S950		SWITCH ASSEMBLY: 160632	Tape-out switch	6-13
A1025		COVER: 154131	Cover for A1027	6-15
A1026		BASE: 154194	Mounting base for contact mechanism	6-15
A1027		BOX, CONTACT: 154130	Container for contact mechanism	6-15
A1028		BRACKET: 156643	Supports A1027	6-15
E1025		INSULATOR: 156663	Insulates O1027 from H1030 and O1028	6-15
E1026		TERMINAL: 154042	Terminal for conductor from Z1025 and W850 or W851	6-15
E1027		SCREW, CONTACT: 154045	Contact for O1030	6-15
E1028		LUG, TERMINAL: 154043	Terminal for conductor from Z1025 and W850 or W851	6-15
E1029		Same as E1028	Terminal for conductor from Z1025 and W850 or W851	6-15
E1030		INSULATOR, STRIP: 154189	Insulates contact mechanism from A1027	6-15
E1031		WASHER, INSULATING: 151182	Insulates O1027 from H1021	6-15
H1000		NUT: 1/4-32 hex 3595	Retains O1000 on O1013	6-14
H1001		WASHER, LOCK: 130667	Retains O1000 on O1013	6-14
H1002		SCREW: 4-40 by 3/16 fil 110434	Retains O1002 on O1003	6-14
H1003		Same as H708	Retains O1002 on O1003	6-14
H1004		Same as H957	Retains O1010 on O1011	6-14
H1005		Same as H708	Retains O1010 on O1011	6-14
H1006		WASHER, FLAT: 42823	Retains O1010 on O1011	6-14
H1007		Same as H957	Retains O1011 on O1013	6-14
H1008		Same as H708	Retains O1011 on O1013	6-14
H1009		Same as H1000	Retains O1012 on O1013	6-14
H1010		Same as H1001	Retains O1012 on O1013	6-14
H1025		SCREW, SHOULDER: 156747	Retains K1025 on A806	6-15
H1026		Same as H702	Retains K1025 on A806	6-15
H1027		WASHER, FLAT: 76099	Retains K1025 on A806	6-15
H1028		Same as H710	Retains A1025 on A1027	6-15
H1029		Same as H708	Retains A1025 on A1027	6-15

TABLE 7-2. DISTRIBUTOR-TRANSMITTER, LIST OF MAINTENANCE PARTS (Continued)

DISTRIBUTOR-TRANSMITTER(Continued)

REF. DES.	NOTES	NAME AND DESCRIPTION	LOCATING FUNCTION	FIG. AND INDEX NUMBER
H1030		SCREW: 2-25 by 9/32 fil 125126	Retains O1027 on O1028	6-15
H1031		WASHER, LOCK: Steel, mfg. code No. 78189, part No. 1202 (code 59433 part No. 90791)	Retains O1027 on O1028	6-15
H1032		SCREW: 4-40 by 1/8 fil 1293	Retains terminals of Z1025 and W850 or W851 on E1026	6-15
H1033		Same as H1032	Retains terminals of Z1025 and W850 or W851 on E1026	6-15
H1034		Same as H708	Retains terminals of Z1025 and W850 or W851 on E1026	6-15
H1035		SCREW: 4-40 by 7/8 fil 151731	Retains A1025 and A1026 on A1027 and A1027 on A1028	6-15
H1036		Same as H859	Retains A1025 and A1026 on A1027 and A1027 on A1028	6-15
H1037		Same as H757	Retains A1026 on A1027	6-15
H1038		SCREW: 4-40 by 3/8 fil 151686. Same as H518	Retains A1026 to A1027 and A1027 to A1028	6-15
H1039		Same as H859	Retains A1026 to A1027 and A1027 to A1028	6-15
H1040		Same as H761	Retains A1027 on A1028	6-15
H1041		Same as H859	Retains A1027 on A1028	6-15
H1042		Same as H708	Retains W850 or W851 on E1026	6-15
K1025		BOX ASSY, CONTACT: 156648	Imposes marking and spacing characteristics on signal line current	6-15
O1000		BEARING, BALL: 130499	Rear bearing for O1013	6-14
O1001		SHIM: 3636	Spaces O1000 from O1013	6-14
O1002		GEAR, HELICAL: 40 tooth 156844	Drives O1003	6-14
O1003		DRUM ASSY, CLUTCH: 156833	Drives O1005 and O1006 when they are engaged	6-14
O1004		SPRING, CLUTCH SHOE: 150241	Applies tension to O1005 and O1006	6-14
O1005		SHOE, SECONDARY: 150043	Drives O1010 when in engaged position	6-14
O1006		SHOE, PRIMARY: 150044	Permits O1005 to drive O1010 when engaged	6-14
O1007		SPRING: 151728	Applies tension to 1008	6-14
O1008		LEVER, CLUTCH SHOE: 150026	Engages and disengages O1005 and O1006	6-14
O1009		WICK, FELT: 150029	Lubricates distributor-transmitter clutch	6-14
O1010		DISK, ADJUSTING: 150013	Drives O1011	6-14
O1011		DISK, CLUTCH CAM: 154694	Drives O1013	6-14
O1012		Same as O1000	Front bearing for O1013	6-14
O1013		CAMSHAFT: 156836	Operates O915	6-14
O1025		SPRING: 86304	Applies tension to O1028	6-15
O1027		TOGGLE: 151171	Operates O1030	6-15
O1028		LINK: 156644	Operates O1027	6-15
O1029		SPRING: 151820	Applies tension to O1030 and E1026	6-15

TABLE 7-2. DISTRIBUTOR-TRANSMITTER, LIST OF MAINTENANCE PARTS (Continued)

DISTRIBUTOR-TRANSMITTER(Continued)

REF. DES.	NOTES	NAME AND DESCRIPTION	LOCATING FUNCTION	FIG. AND INDEX NUMBER
O1030 O1031 Z1025		LINK, TOGGLE: 151180 ECCENTRIC: 154095 CAPACITOR-RESISTOR: 1, 0. 1 mfd $\pm 20\%$, 300 VDC working 1, 470 ohms, 1/2 w (code 59433 part No. 154166)	Retains O1027 in position Adjust position of K1025 Signal line radio interference suppressor	6-15 6-15 6-15

TABLE 7-3. LIST OF MANUFACTURERS

CODE NUMBER	NAME	ADDRESS
06175	Bausch & Lomb Optical Co.	Rochester, N. Y.
27395	Samuel Harris Co.	Chicago, Ill.
59433	Teletype Corp.	Skokie, Ill.
64959	Western Electric Co.	New York, N. Y.
70788	Berry Bearing Co.	Chicago, Ill.
71111	Boye Needle Co.	Chicago, Ill.
71616	Commercial Plastics Co.	Chicago, Ill.
74861	Industrial Condenser Corp.	Chicago, Ill.
78189	Shakeproof, Inc., Division of Illinois Tool Works	Chicago, Ill.
97464	Industrial Retaining Ring Co.	Mt. Vernon, N. Y.

SUBJECT	PARA- GRAPH
	(Figure) *Table
C — Continued	
Contractor	1-4c
Control Mechanism	(4-6)
Controls	
Automatic	3-4
Manual	3-3
Cover, Adjustments	6-4b(4)
Assembly	2-5d
Description	1-3a
Exploded View	(5-10)
Lubrication	(5-10)
Miniaturized	1-3a
Removal and Repair	6-3b
Cover Plate	
Detent Adjustment	(6-33)
Exploded View	(6-7)
Mounting Adjustment	(6-22)
Removal and Repair	6-3d(1)
Cutout, Overload	3-6

D

Description, Base	1-3b
Cover	1-3a
Distributor-Transmitter	1-3d
Major Components	1-3
Motor	1-3c
Detent, Cover Plate Adjustment	(6-33)
Diagrams	
Actual Wiring, TT-187/UG or TT-187A/UG	(6-36)
Block	(4-1)
Main Power Distribution	(6-35)
Schematic	
Motor	(4-17)
TT-187/UG or TT-187A/UG	(6-37)
Wiring	6-5
Dimensions, Mounting	(2-1)
Distributor-Transmitter	(1-1), (1-2), (1-3), (1-4)
Adjustments	6-4b(1), (6-17) to (6-32)
Clutch	(6-17)
Clutch Trip Magnet	(6-32)
Clutch Trip Mechanism	(6-18)
Code Sensing Fingers	(6-27)
Cover Plate Detent	(6-33)
Cover Plate Mounting	(6-22)
Feed Pawl Mechanism	(6-28)
Line Shunt Switch	(6-33)
Main Bail Assembly	(6-26)
Main Bail Trip Assembly	(6-29)
Signal Generator	(6-31)
Start-Stop Switch	(6-25)
Tape Guide Plate	(6-19)
Tape Guide Plate Mounting	(6-21)
Tape Lid	(6-20)
Tape-Out Contact	(6-23)
Tape-Out Sensing Pin	(6-24)
Top Plate Mounting	(6-22)
Transfer Bail Stabilizer	(6-30)
Transfer Lever Spring	(6-28)

D — Continued

Assembly	2-5b
Components	*1-1
Description	1-3d
List of Maintenance Parts	*7-2
List of Major Components	*7-1
Lubrication	(5-3) to (5-9)
Removal and Repair	6-3d
Center Plate Mechanism	6-3d(5)
Contact Box	6-3d(7)
Cover Plate	6-3d(1)
Main Shaft	6-3d(6)
Tape Guide Plate	6-3d(3)
Top Plate	6-3d(2)
Theory of Operation	4-3
Drive Arm	(4-10)

E

Electrical	
Characteristics	1-4h
Connections	2-4
Contacts, Adjustments	6-4a(6)
Features, Distributor-Transmitter	4-3b
Equipment Not Supplied	*1-4
Equipment Supplied	*1-2
Exploded View	
Base	(6-2)
Intermediate Gears	(6-4)
Miniaturized	(6-3)
Cover	(6-1)
Distributor-Transmitter	(6-7) to (6-15)
Cam-Clutch Main Shaft	(6-14)
Center Plate	(6-11)
Clutch Trip Magnet	(6-10)
Contact Box Assembly	(6-15)
Cover Plate	(6-7)
Front Plate	(6-12), (6-13)
Rear Plate	(6-9)
Tape Guide Plate	(6-8)
Top Plate	(6-7)
Intermediate Gear Mechanism	(6-4)
Motor	(6-5)
Motor, Miniaturized	(6-6)

F

Failure Report	6-1
Feed Mechanism Adjustment	(6-28)
Free Wheeling	4-3d(2)
Lubrication	(5-8)
Theory of Operation	5-3d(5), (4-13)
Final Checks	2-9
Final Test	6-4
Fingers, Sensing, Adjustment	(6-27)
Free Wheeling Feed Wheel, Theory of Operation	4-3d(2), (4-12)
Front Plate, Exploded View	(6-12), (6-13)
Lubrication	(5-8)
Mechanism	(4-7)

SUBJECT
PARA-
GRAPH

(Figure)
*Table

SUBJECT
PARA-
GRAPH

(Figure)
*Table

G-H-I

Illustration Orientation 6-4a(2)
Input, Signal Intelligence 4-3d
Installation
 Assembly of Equipment 2-5
 Base 2-3
 General 2-1
 Unpacking 2-2
Intermediate Gear Mechanism, Exploded View . (6-4)

J-K-L

Line Shunt Switch Adjustment (6-33)
List of Major Components 7-2
List of Manufacturers 7-4, *7-3
Locking Bail, Theory of Operation 4-3f, (4-14)
Lubrication 5-5
 Base (5-10)
 Center Plate Mechanism (5-7)
 Cover (5-10)
 Clutch Trip Mechanism (5-5)
 Distributor-Transmitter (5-3) to (5-9)
 Feed Mechanism (5-8)
 Front Plate (5-8)
 Main Shaft (5-6)
 Motor (5-2)
 Oil Reservoir (5-6)
 Sensing Mechanism (5-8)
 Signal Contact Assembly (5-4)
 Tape Guide Plate (5-3)
 Transfer Mechanism (5-9)

M

Magnet, Clutch Trip
 Adjustment (6-32)
 Exploded View (6-10)
Main Bail (4-10)
 Adjustment (6-26)
 Trip Assembly Adjustment (6-29)
Main Power Distribution Diagram (6-35)
Main Power Switch 3-5b
Main Shaft, Cam-Clutch 4-3c, (4-4)
 Exploded View (6-14)
 Lubrication (5-6)
 Removal and Repair 6-3d(6)
Maintenance Check Chart, Routine *5-2
Maintenance Parts List 7-3, *7-2
Manual Checks 3-5
Manufacturers, List of 7-4, *7-3
Mechanical Checking of Equipment 2-6
Motor, Adjustments 6-4b(3)
 Assembly 2-5a
 Description 1-3c(2)
 Exploded View (6-5)
 Lubrication (5-2)
 Miniaturized

M — Continued

Description 1-3c(3)
Exploded View (6-6)
Lubrication (5-2)
Overload Cutout 3-6
 Removal and Repair 6-3c(2)
 Schematic Wiring Diagram (4-17)
 Theory of Operation 4-5
Overload Cutout 3-6
 Removal and Repair 6-3c(1)
 Schematic Wiring Diagram (4-17)
 Theory of Operation 4-5
Mounting, Cover Plate, Adjustments (6-22)
 Dimensions (2-1)
 Tape Guide Plate, Adjustments (6-21)
 Top Plate, Adjustments (6-22)

N

Nomenclature 1-4a

O

Oil Reservoir (5-6)
Operating Procedures 3-3
Operating Tests 2-7
Operation, Controls, Automatic 3-4
 Preparation for Use 3-2
 Theory of 4-1
Outline and Mounting Dimensions 2-1
Overload Cutout 3-6

P

Parts List 7-1, *7-2
Pin, Tape-Out Sensing, Adjustments 6-24
Plate, Center, Exploded View (6-11)
 Lubrication (5-7)
 Removal and Repair 6-3d(5)
Plate, Cover, Detent Adjustments (6-33)
 Exploded View (6-7)
 Mounting, Adjustments (6-22)
 Removal and Repair 6-3d(1)
Plate, Front (4-7)
 Exploded View (6-12), (6-13)
 Lubrication (5-8)
Plate, Rear
 Exploded View (6-9)
 Removal and Repair 6-3d(4)
Plate, Tape Guide,
 Adjustments (6-19)
 Exploded View (6-8)
 Lubrication (5-3)
 Mounting, Adjustments (6-21)
 Removal and Repair 6-3d(3)
Plate, Top, Exploded View (6-7)
 Mounting, Adjustments (6-22)
 Removal and Repair 6-3d(2)

SUBJECT
PARA-
GRAPH

(Figure)
*Table

SUBJECT
PARA-
GRAPH

(Figure)
*Table

P - Continued

Power Line Connections 2-4
Power, Main Distribution Diagram (6-35)
Preparation for Use 3-2
Preventive Maintenance 5-1
Purpose of Equipment 1-2

Q-R

Rear Plate
Exploded View (6-9)
Removal and Repair 6-3d(4)
Reference Data 1-4
Removal and Repair 6-3
Base 6-3e(1)
Base, Miniaturized 6-3e(2)
Cover 6-3b
Distributor-Transmitter 6-3d
Motor 6-3c(1)
Motor Miniaturized 6-3c(2)
Repair 6-2, 6-3
Report, Failure 6-1
Reservoir, Oil, Lubrication (5-6)
Routine Maintenance Check Chart 5-3, *5-2

S

Schematic Wiring Diagram
Motor (4-17)
TT-187/UG or TT-187A/UG (6-37)
Sensing Mechanism
Adjustments (6-27)
Lubrication (5-8)
Theory of Operation 4-3e, (4-14)
Sensing Pin, Tape-Out, Adjustments (6-24)
Service 6-2
Shaft, Main (4-4)
Exploded View (6-14)
Lubrication (5-6)
Removal and Repair 6-3d(6)
Shipping Data 1-4e, f, g, *1-3
Signal Contact Assembly, Lubrication (5-4)
Signal Generator,
Adjustments (6-31)
Theory of Operation 4-3g, (4-15)
Signaling Code
Theory of Operation 4-2, (4-2)
Transmission Patterns *4-1
Signal Input 4-3d
Signal Line Connections 2-4
Stabilizer
Transfer Bail (4-16)
Transfer Bail Adjustments (6-30)
Start-Stop Lever (4-4)
Start-Stop Switch 3-5c, (6-25)
Switch
Line Shunt, Adjustments (6-33)
Main Power 3-5b

S - Continued

Motor Overload 3-4a
Start-Stop 3-5c, (4-5), (6-25)
Tape-Out 3-4c
Adjustments (6-23)
Theory of Operation 4-3d(3)
Thermal 3-6
Tight Tape 3-4b, 4-3d(4), (4-5)

T

Tape Feed, Theory of Operation 4-3d(5), (4-13)
Tape Guide Plate
Adjustments (6-19)
Exploded View (6-8)
Lubrication (5-3)
Mounting, Adjustments (6-21)
Removal and Repair 6-3d(3)
Tape Lid 4-3d(1), (4-10)
Adjustments (6-20)
Contact Adjustments (6-23)
Control 34-c, (4-12)
Release Button 3-5c
Sensing Pin Adjustments (6-24)
Switch, Theory of Operation 4-3d(3)
Tape, Path in Distributor-Transmitter (3-1)
Test, Final 6-4c
Tests, Operating 2-7
Theory of Operation 4-1
Base 4-4
Cover 4-6
Distributor-Transmitter 4-3
Motor 4-5
Signaling Code 4-2, (4-2), *4-1
Cam-Clutch Main Shaft 4-3c, (4-4)
Clutch
Disengaged (4-8)
Engaged (4-9)
Control Mechanism (4-6)
Drive Arm Mechanism (4-10)
Electrical Features 4-3b
Free Wheeling Feed Wheel 4-3d(2), (4-12)
Front Plate Mechanism (4-7)
Locking Bail 4-3f, (4-14)
Main Bail (4-10)
Sensing Mechanism 4-3e, (4-14)
Signal Generator 4-3g, (4-15)
Signal Input 4-3d
Start-Stop Lever (4-5)
Tape Feed Mechanism 4-3d(5), (4-13)
Tape Lid 4-3d(1), (4-10)
Tape-Out Switch 4-3d(3), (4-12)
Tight Tape Switch 4-3d(4)
Transfer Bail Stabilizer (4-16)
Transfer Lever Mechanism (4-14)
Transfer Mechanism 4-3f
Tight Tape Control 3-4b
Tight Tape Switch, Theory of Operation 4-3d(4), (4-5)

SUBJECT
 PARA-
 GRAPH
 (Figure)
 *Table

SUBJECT
 PARA-
 GRAPH
 (Figure)
 *Table

T - Continued

Tools 5-2, (5-1), *5-1
 Top Plate
 Exploded View (6-7)
 Mounting, Adjustments (6-22)
 Removal and Repair 6-3d(2)
 Transfer Bail Stabilizer (4-16), (6-30)
 Transfer Lever Spring, Adjustment (6-28)
 Transfer Mechanism
 Lubrication (5-9)
 Theory of Operation 4-3f, (4-14)
 Trip Assembly, Main Bail, Adjustments (6-29)
 Trip Magnet, Clutch
 Adjustments (6-32)
 Exploded View (6-10)
 Trip Mechanism, Clutch
 Adjustments (6-18)
 Lubrication (5-5)
 Trouble Shooting 5-1, 5-4, *5-2
 TT-187/UG
 Actual Wiring Diagram (6-36)
 Components *1-1
 List of Maintenance Parts *7-2

T - Continued

List of Major Components *7-1
 Schematic Wiring Diagram (6-37)
 TT-187A/UG
 Actual Wiring Diagram (6-36)
 Components *1-1
 List of Maintenance Parts *7-2
 List of Major Components *7-1
 Schematic Wiring Diagram (6-37)

U

Unpacking 2-2

V-W-X-Y-Z

Winding Data *6-1
 Wiring, Base (2-2)
 Diagrams 6-5
 Actual, TT-187/UG or TT-187A/UG (6-36)
 Schematic
 Motor (4-17)
 TT-187/UG or TT-187A/UG (6-37)

