

TABLE 4-1. TEST EQUIPMENT AND SPECIAL TOOLS

NAME	DESIGNATION	ALTERNATE	REQUIRED USE
Oscilloscope	AN/USM-105	Oscilloscope AN/USM-50	Observe waveforms.
Multimeter	AN/PSM-4	Electronic Multimeter TS-505/U	Perform resistance, current, and voltage measurements.
Teletypewriter Tool Kit TK-122/U*			Perform minor adjustments.

\*This tool kit contains all special tools and gages required to maintain the teletypewriter sets.

TABLE 4-2. PRELIMINARY CHECKS FOR EQUIPMENT ALREADY IN USE

STEP NO.	ACTION	PROCEDURE OR REFERENCE
1.	Check for presence of primary power.	Remove service cable from primary power source; using Multimeter AN/PSM-4, check power source for correct primary power.
2.	Check for presence of correct fuses; using Multimeter AN/PSM-4, check for continuity.	Refer to figure 2-1; replace defective fuses.
3.	Check that option patch cords are secure; check option patching arrangement for operating mode in use.	Refer to paragraph 2-9.
4.	Check motor and selector cable connectors for security in their receptacles; check all service cable junction box connections for security.	Tighten or repair loose or damaged connections.
5.	Check keyboard and electrical chassis slip contacts for continuity and correct operation. Check service cable for signs of deterioration; connect service cable to primary power source. Check cable connector for security with electrical chassis receptacle.	Tighten loose connections.
6.	Check signal line current.	Using Multimeter AN/PSM-4, check incoming signal line current:  High Range - 20 to 80 ma Low Range - 1 to 5 ma
7.	Check signal line distortion.	Check for maximum of 35-percent distortion on incoming signal. Refer to paragraph 4-11 for a description of the types of distortion which may be encountered.
8.	Proceed to table 4-4 (Appendix) for troubleshooting procedures.	

TABLE 4-3. PRELIMINARY CHECKS FOR EQUIPMENT OF UNKNOWN CONDITION

STEP NO.	ACTION	PROCEDURE OR REFERENCE
1.	Perform thorough visual inspection; check for missing or damaged components and security of all connectors and patch cords. Check belt and cables for wear and proper threading.	Refer to Section 1 for general overall illustrations of the complete equipment. Refer to Section 5 for belt and cable threading instructions.
2.	Determine the type of primary power required and connect the teletypewriter set to the applicable primary power source.	Refer to paragraph 2-5.
3.	Perform all checks of table 4-2 (Appendix).	

TABLE 4-4. SYSTEM TROUBLE-SHOOTING CHART

SYMPTOM	PROBABLE CAUSE	CORRECTIVE ACTION
	NOTE	
	Prior to using this chart, perform the test setup of paragraph 4-5b.	
1. Both motor and copy lights inoperative.	Defective main fuse 1A1F1.	Replace fuse.
	Defective MOTOR switch	Replace switch.
	Open or shorted wire.	Perform continuity check using figure 4-6 (Appendix) and Multimeter AN/PSM-4. Replace or solder broken or shorted wire.
	Broken or bent connector pin.	Replace connector assembly.
2. Motor inoperative (copy lights operative).	Defective motor fuse 1A1F2.	Replace fuse.
	Faulty motor.	Perform continuity check between power leads and chassis. See figure 4-6 (Appendix). Replace or solder broken or shorted wire.
Motor inoperative; slight movement of gears when MOTOR switch is turned on.	Faulty starting capacitor 1A1C1 (one side open or shorted).	Test for shorted or open condition. Replace if defective.
	Motor stop relay 1A1K1 continuously energized due to defective or mis-adjusted relay, line sensor, or switch 1A2A1S1.	Repair or replace defective parts; refer to table 4-6 (Appendix) for line sensor troubleshooting procedures.
	Defective motor stop circuit in line sensor.	Refer to table 4-6 (Appendix).
3. Copy lights inoperative.	Faulty LAMP switch 1A1S2.	Replace switch.
	Faulty bulbs.	Replace bulbs.
	Open wire or connection.	Perform continuity checks.
	Transformer 1A3T1 defective.	Replace transformer.

TABLE 4-4. SYSTEM TROUBLE-SHOOTING CHART (Cont.)

SYMPTOM	PROBABLE CAUSE	CORRECTIVE ACTION
<p>4. Motor will not stop with figures H function (AN/TGC-14(V)). Motor stop relay 1A1K1 will not energize.</p> <p>Motor will not stop after 60 to 90 seconds inactivity (no mark-to-space) transition (AN/TGC-14A(V)).</p>	<p>Figures H linkage improperly adjusted.</p> <p>Defective figures H motor stop switch 1A2A1S1.</p> <p>Motor stop relay 1A1K1 coil open.</p> <p>Open wire or connection.</p> <p>Defective line sensor.</p> <p>Code bar binding; code bar not closing figures H motor stop switch.</p> <p>Time delay motor stop mechanism improperly adjusted.</p> <p>Defective time delay switch 1A2A1S1.</p> <p>Defective motor stop relay 1A1K1.</p> <p>Defective line sensor.</p> <p>Open wire or connection.</p>	<p>Perform figures H motor stop linkage adjustment (paragraph 5-4e(23)(b)).</p> <p>Replace switch (figure 5-55, Appendix).</p> <p>Replace relay (figure 4-37, Appendix).</p> <p>Perform continuity checks in motor stop circuit.</p> <p>Refer to table 4-6 (Appendix).</p> <p>Correct the cause of binding; repair or replace code bar spring.</p> <p>Adjust according to paragraph 5-4e(23)(a).</p> <p>Replace switch (figure 5-54, Appendix).</p> <p>Replace relay (figure 4-37, Appendix).</p> <p>Refer to table 4-6 (Appendix).</p> <p>Perform continuity checks in motor stop circuit.</p>
<p>5. Motor speed fluctuates.</p>	<p>Input power (voltage or frequency) variations.</p> <p>Binding component in printer.</p> <p>Erratic operation of motor stop switch 1A2A1S1 (AN/TGC-14(V)).</p>	<p>Check primary power.</p> <p>Check clutches, gears, cams, and linkages for free movement; if necessary, lubricate parts according to table 5-9 (Appendix).</p> <p>Adjust figures H motor stop linkage (paragraph 5-4e(23)(b)).</p>
<p>6. Heater inoperative.</p>	<p>Thermostat 1A1S3 inoperative.</p> <p>Defective heating element.</p> <p>Defective fuse 1A1F1 (AN/TGC-14(V)) or 1A1F1 or 1A1F4 (AN/TGC-14A(V)).</p>	<p>Replace thermostat.</p> <p>Perform continuity check of heating element: 66.5 ohms <math>\pm</math>10%.</p> <p>Replace fuse.</p>
<p>7. Printer runs open; meter shows signal line current.</p> <p>Printer runs open.</p>	<p>Defective line sensor.</p> <p>Faulty start clutch or clutch release finger adjustment.</p> <p>No mark signal being transmitted.</p> <p>Signal line fuse 1A1F4 (AN/TGC-14(V)) or 1A1F5 (AN/TGC-14A(V)).</p> <p>Signal loop open.</p>	<p>Refer to table 4-6 (Appendix).</p> <p>Adjust according to paragraph 5-4e(5).</p> <p>Check signal line and/or remote operator.</p> <p>Replace fuse.</p> <p>Patching not proper for operating mode. Patch correctly as instructed in paragraph 2-9.</p>

TABLE 4-4. SYSTEM TROUBLE-SHOOTING CHART (Cont.)

SYMPTOM	PROBABLE CAUSE	CORRECTIVE ACTION
Printer runs open (Cont.)	Faulty contact on contact block 1A1S4 (AN/TGC-14(V)) or 1A1E8 (AN/TGC-14A(V)).  Signal line power supply inoperative.  Defective line sensor.  Open wire.  Open signal line in service cable.	Replace contact block.  Refer to table 4-9 (Appendix).  Refer to table 4-6 (Appendix).  Perform continuity check on signal line.  Perform continuity checks on service cable.
8. Printer runs closed but does not print.	Printer improperly patched.  Poor solder connections on patch cords.  Defective line sensor.  Start clutch not releasing.  Selector improperly adjusted or faulty.	Refer to patching instructions in paragraph 2-9.  Resolder patch cords.  Refer to table 4-6 (Appendix).  Adjust start clutch as instructed in paragraph 5-4e(5).  Adjust selector as instructed in paragraph 5-4e(16) or replace selector.
9. Teletypewriter set prints garbled message.	Range dial out of adjustment.  Incorrect speed gear installed.  Line current at improper value or distorted.  Selector improperly adjusted.  Defective line sensor.  Start clutch improperly adjusted.  Signal line power supply output high or low.  Loose selector bar (12, figure 5-75, Appendix).  Figures H motor stop linkage out of adjustment (AN/TGC-14(V)).  Defective clutch.	Adjust as instructed in paragraph 2-8e(1). Check for broken setscrew (AN/TGC-14(V) only) on range dial; replace if broken.  Install correct speed gear as instructed in paragraph 2-10.  Readjust; trace source of distortion.  Adjust selector as instructed in paragraph 5-4e(16).  Refer to table 4-6 (Appendix).  Adjust as instructed in paragraph 5-4e(5).  Refer to table 4-9 (Appendix).  Tighten selector bar screws.  Adjust as instructed in paragraph 5-4e(23)(b).  Check all clutches for operation by sending RYRY (all clutches should release). Replace defective clutch.

TABLE 4-4. SYSTEM TROUBLE-SHOOTING CHART (Cont.)

SYMPTOM	PROBABLE CAUSE	CORRECTIVE ACTION
<p>Teletypewriter set prints garbled message (Cont.)</p> <p>10. Depressing any key does not produce output signal.</p> <p>11. Printer prints copy received from remote station but not from local keyboard.</p> <p>12. No printing; selection taking place.</p>	<p>Timing marks on timing cam shaft gear and start clutch gear (figure 5-99, Appendix) not aligned.</p> <p>Dirty print cylinder shaft.</p> <p>Function slides out of adjustment and random functions are selected.</p> <p>Rotary spring broken.</p> <p>SEND•REC-REC switch in REC position.</p> <p>Printer not seated correctly on electrical chassis.</p> <p>Master pulsing contacts out of adjustment.</p> <p>Keyboard slip connector contact 1A9E1 defective.</p> <p>Keyboard not in correct operating position.</p> <p>Incorrect patching.</p> <p>Keyboard clutch release finger (figure 4-7, Appendix) does not clear tab.</p> <p>Keyboard drive gear stripped (figure 4-7, Appendix).</p> <p>Defective keyboard.</p> <p>SEND•REC-REC switch 1A9S3 defective or in REC position.</p> <p>Keyboard filter 1A9FL1 open or shorted.</p> <p>Incorrect patching.</p> <p>Open wire or connection.</p> <p>Contact block 1A1S4 (AN/TGC-14(V) or 1A1E8 (AN/TGC-14A(V)) defective.</p> <p>Keyboard clutch not engaged.</p> <p>Master pulsing contacts out of adjustment.</p> <p>Print and function clutch (figure 4-24, Appendix) not operating correctly.</p> <p>Print prevent adjustment incorrect.</p>	<p>Align three dots on start clutch gear with two dots on timing cam shaft gear ( :: ).</p> <p>Clean print cylinder shaft.</p> <p>Perform function slide and stroke adjustments (paragraphs 5-4e(3)(b) and 5-4e(4)(b)).</p> <p>Replace spring (figure 5-100, Appendix).</p> <p>Place switch in SEND•REC position.</p> <p>Position printer correctly.</p> <p>Readjust on local mode (paragraph 5-4e(25)(i) or 5-4e(27)(b)).</p> <p>Repair or replace contact.</p> <p>Pull keyboard out to correct position.</p> <p>Patch correctly (paragraph 2-9).</p> <p>Adjust according to paragraph 5-4e(25)(a).</p> <p>Replace gear.</p> <p>Refer to table 4-5 (Appendix).</p> <p>Replace switch or set to SEND•REC position.</p> <p>Replace filter.</p> <p>Patch correctly (paragraph 2-9).</p> <p>Perform continuity checks.</p> <p>Replace contact block.</p> <p>Engage clutch.</p> <p>Readjust contacts (paragraphs 5-4e(25)(i) and 5-4e(27)(b)).</p> <p>Check clutch for correct operation; repair or replace if necessary.</p> <p>Adjust according to paragraph 5-4e(18).</p>

TABLE 4-4. SYSTEM TROUBLE-SHOOTING CHART (Cont.)

SYMPTOM	PROBABLE CAUSE	CORRECTIVE ACTION
No printing; selection taking place (Cont.)	Print hammer actuating adjustment incorrect.	Adjust according to paragraphs 5-4e(14) and 5-4e(15).
13. No function selection; printing taking place.	Defective print hammer actuator link helical spring (39, figure 5-82, Appendix).	Replace spring.
	Defective print helical spring (18, figure 5-79, Appendix).	Replace spring.
	Defective print cam follower (37, figure 5-84, Appendix).	Adjust, repair, or replace.
14. Printing on functions.	Broken function lever lifter arm screw or function cam follower screw (59 and 90, figure 5-85, Appendix).	Drill out broken portion and replace with stainless-steel screws.
	Function bar is not set high enough to clear sensing finger levers on high side of function cam.	Adjust function lever lifter arm or entire function section (paragraph 5-4e(6)(b)).
	Print prevent adjustment screws (44, figure 5-86, Appendix) improperly adjusted.	Adjust according to paragraph 5-4e(18).
	Print prevent rod lever (48, figure 5-86, Appendix) worn.	Replace with stellite-tipped part.
	Print prevent arm (36, figure 5-84, Appendix) worn or out of adjustment.	Adjust arm (paragraph 5-4e(18)) or replace if defective.
	Defective print prevent rod actuator arm bias spring (38, figure 5-86, Appendix).	Replace spring.
	Incorrect stroke adjustment	Adjust according to paragraph 5-4e(17).
15. Printing on space.	Function slides (figures 5-19 and 5-20, Appendix) out of adjustment.	Adjust according to paragraphs 5-4e(3)(b) and 5-4e(4)(b).
	Function bar (87, figure 5-85, Appendix) out of adjustment.	Adjust according to paragraph 5-4e(6)(b).
	Broken function backstop clutch release arm return helical spring (figure 4-25, Appendix).	Replace spring.
	Space print prevent adjustment screw (47, figure 5-95, Appendix) incorrectly adjusted.	Adjust according to paragraph 5-4e(18).
16. Functions during printing.	Function bar adjustment incorrect.	Adjust according to paragraph 5-4e(6)(b).
	Function slides (figures 5-17 and 5-20, Appendix) out of adjustment.	Adjust according to paragraphs 5-4e(3)(b) and 5-4e(4)(b).
17. Occasional misprint.	Range dial out of adjustment	Adjust according to paragraph 2-8e(1) or (2).
	Signal line distortion.	Check for maximum of 35-percent distortion.

TABLE 4-4. SYSTEM TROUBLE-SHOOTING CHART (Cont.)

SYMPTOM	PROBABLE CAUSE	CORRECTIVE ACTION
Occasional misprint (Cont.)	Defective rotary detent pawl (22, figure 5-101, Appendix).  One or more type positioning clutches (figure 4-19, Appendix) not functioning correctly.  Start clutch release adjustment incorrect.  Selector adjustment incorrect.  Selector armatures (figure 5-102, Appendix) binding on pole pieces.  Incorrect signal line current.  Defective line sensor.  Dirty print cylinder shaft (figure 4-19, Appendix).  Defective clutch release finger (figure 4-22, Appendix, typical).	Repair or replace pawl.  Check for correct operation.  Adjust according to paragraph 5-4e(5).  Adjust according to paragraph 5-4e(16).  Check and remove cause of binding.  Using Multimeter AN/PSM-4, check for 60 ma on high range or 5 ma on low range.  Refer to table 4-6 (Appendix).  Clean shaft.  Repair or replace finger.
18. Printing too lightly.	Defective or twisted ribbon.        Print hammer shaft stop (52, figure 5-82, Appendix) not adjusted properly.	If defective, replace ribbon according to paragraph 3-3c(2). If twisting or folding, correct by raising retaining rings (6, figure 5-81, Appendix) to allow the ribbon guide rollers to follow the ribbon action. If condition persists, loosen ribbon vibrator arm screw (print hammer in non-print position) and adjust ribbon vibrator arms so that the ribbon is just under the last line printed.        Adjust according to paragraph 5-4e(13).
19. Uneven spacing between characters.	Dirty print cylinder shaft (figure 4-19, Appendix).  Incorrect stroke adjustment.  Loose frame clamp (14, figure 5-79, Appendix).	Replace pad.  Clean shaft.  Adjust according to paragraph 5-4e(17).  Tighten all loose frame clamps.
20. Print hammer hitting only half of character. (Refer to figure 4-19, Appendix.)	Function slides out of adjustment.  Print hammer and print cylinder out of alignment.  Cables and belt not running on their pulleys.	Adjust according to paragraphs 5-4e(3)(b) and 5-4e(4)(b).  Adjust according to paragraph 5-4e(12).  Check that cables and belt are installed as shown in figure 4-19, Appendix.

TABLE 4-4. SYSTEM TROUBLE-SHOOTING CHART (Cont.)

SYMPTOM	PROBABLE CAUSE	CORRECTIVE ACTION
<p>21. Printing only top or bottom of characters. (Refer to figure 4-19, Appendix)</p>	<p>Rotary function slide out of adjustment.</p> <p>Rotary adjustment incorrect.</p> <p>Clearance between rotary detent pawl pin and index wheel (24, figure 5-101, Appendix) incorrect.</p> <p>Broken rotary detent pawl spring on detent arm (46, figure 5-85, Appendix).</p> <p>Print cylinder shaft binding.</p> <p>Defective print hammer face pad.</p>	<p>Adjust according to paragraph 5-4e(3)(b).</p> <p>Perform all rotary adjustments in paragraph 5-4e(17)(a).</p> <p>Adjust according to paragraph 5-4e(7).</p> <p>Replace spring.</p> <p>Check and remove cause of binding.</p> <p>Replace pad.</p>
<p>22. No carriage advance.</p>	<p>Character advance pawl and check pawl eccentric bushings (3 and 19, figure 5-101, Appendix) out of adjustment.</p> <p>Carriage return lock lever (figures 5-31 and 5-32, Appendix) not dropping out of carriage return cam follower.</p> <p>First character adjustment screw (figure 5-52, Appendix) loose.</p> <p>Random advance prevention function selected.</p> <p>Broken or damaged character advance pawl or check pawl springs (36 and 62, figure 5-85, Appendix).</p> <p>Character advance pawl, check pawl, or advance ratchet worn (figure 5-29, Appendix).</p>	<p>Adjust according to paragraph 5-4e(8).</p> <p>Adjust according to paragraph 5-4e(9)(a).</p> <p>Tighten and adjust according to paragraph 5-4e(21).</p> <p>Adjust function slides according to paragraphs 5-4e(3)(b) and 5-4e(4)(b).</p> <p>Check springs and replace defective units.</p> <p>Check for wear and replace if necessary.</p>
<p>23. No line feed.</p>	<p>Refer to first three entries of Symptom 15.</p> <p>Line feed actuator cam follower arm (figure 4-28A, Appendix) out of adjustment.</p> <p>Pressure release lever in RELEASE position.</p> <p>Paper supply roll not rotating freely on electrical chassis.</p> <p>Function lever lifter arm out of adjustment.</p> <p>Pressure roll (16, figure 5-83, Appendix) not clamping paper.</p>	<p>Refer to Symptom 15.</p> <p>Readjust according to paragraph 5-4e(11).</p> <p>Move lever to LOCK position.</p> <p>Check installation of paper supply roll and tension on dancer roll tube.</p> <p>Adjust according to paragraph 5-4e(6)(c).</p> <p>Check for damaged pressure roll springs or binding pressure roll shaft.</p>



TABLE 4-4. SYSTEM TROUBLE-SHOOTING CHART (Cont.)

SYMPTOM	PROBABLE CAUSE	CORRECTIVE ACTION
No line feed (Cont.)	Paper feed binding (Tactical Case CY-2976/PG).	Check that pressure release lever is set correctly. Check that the front of the case is not sagging. If case has not been modified, install Modification Kit Part No. 30561 (table 1-3).
24. No carriage return.	<p>Dirty paper feed rubber roll.</p> <p>Line feed clutch (figure 5-33, Appendix) not operating.</p> <p>Refer to first three entries of Symptom 15.</p> <p>Check pawl (figure 5-29, Appendix) does not clear advance ratchet.</p> <p>Carriage return spiral spring (9, figure 5-84, Appendix) broken or disengaged.</p>	<p>Clean roll.</p> <p>Check for defect and repair or replace.</p> <p>Refer to Symptom 15.</p> <p>Adjust according to paragraph 5-4e(9)(a).</p> <p>Replace or engage spring.</p>
25. No blank function.	Refer to Symptom 15, except check blank print prevent adjustment screw (46, figure 5-95, Appendix).	Refer to Symptom 15.
26. No space function.	<p>Same as no carriage advance (Symptom 22).</p> <p>Refer to first three entries of Symptom 15.</p>	<p>Refer to Symptom 22.</p> <p>Refer to Symptom 15.</p>
27. No letters function.	<p>Letters sensing finger lever (figure 4-28, Appendix) stuck in function slide.</p> <p>Letters figures clutch (figure 4-28, Appendix) not operating.</p> <p>Incorrect stroke adjustment.</p> <p>Rotary spring (figure 5-100, Appendix) broken.</p>	<p>Release lever.</p> <p>Check clutch for proper operation.</p> <p>Adjust according to paragraph 5-4e(17).</p> <p>Replace spring.</p>
28. No figures function.	Same as no letters function (Symptom 27).	Refer to Symptom 27.
29. No bell function.	<p>Refer to first three entries of Symptom 15 and Symptom 27.</p> <p>Bell function linkage (figure 5-35, Appendix) does not fully return.</p>	<p>Refer to Symptom 15 and Symptom 27.</p> <p>Inspect for fault and correct.</p>
30. No lateral movement. (Refer to figure 4-19, Appendix.)	<p>Jammed function slides.</p> <p>Defective lateral tension helical spring.</p> <p>Cables or belt not functioning.</p>	<p>Release function slides.</p> <p>Replace spring.</p> <p>Inspect for fault and correct.</p>

TABLE 4-4. SYSTEM TROUBLE-SHOOTING CHART (Cont.)

SYMPTOM	PROBABLE CAUSE	CORRECTIVE ACTION
31. No rotary movement.	Defective rotary spring (figure 5-100, Appendix).  Defective rotary cable (figure 4-19, Appendix).  Rotary detent pawl (22, figure 5-4, Appendix) adjustment incorrect.  Defective clutch.	Replace rotary spring.  Replace rotary cable.  Adjust according to paragraph 5-4e(7).  Check clutches for correct operation.
32. No automatic carriage return and line feed.	Incorrect adjustment.	Adjust according to paragraph 5-4e(9)(b).
33. Automatic carriage return but no line feed.	Incorrect alignment of automatic carriage return and line feed sensing finger levers (figure 4-31A, Appendix).	Adjust automatic carriage return actuator eccentric and actuator arm according to paragraph 5-4e(9)(b).
34. Carriage return after 4 or 5 characters from left side margin.	Incorrect automatic carriage return adjustment.  Bounce prevent lever (21, figure 5-85, Appendix) not seating in teeth of V lever assembly (35, figure 5-77, Appendix).	Adjust according to paragraph 5-4e(9)(b)  Adjust bounce prevent lever (paragraph 5-4e(20) or first character adjustment screw (paragraph 5-4e(21))).
35. Slow carriage return. (Refer to figure 4-19, Appendix.)	Dirty print cylinder shaft.  Print hammer binding.  Cables may be tight or damaged.  Number of turns on takeup drum insufficient; carriage return spiral spring eyelet (9, figure 5-84, Appendix) not engaging tab on carriage return spring mounting cup (11).	Clean shaft.  Check and remove cause of binding.  Loosen or replace cables.  Detach cables and lateral control belt; turn takeup drum counterclockwise two turns; install cables and belt; bend end of spiral spring to insure that eyelet engages tab of cup.
36. Advancing on advance prevent functions. (Refer to figure 4-31, Appendix.)	Incorrect stroke adjustment.  Function advance prevent adjustment screws on advance prevent bail carriage return bar out of adjustment.	Adjust according to paragraph 5-4e(17)  Adjust according to paragraph 5-4e(19).
37. Double line feed every time.	Shift linkage on line feed (figure 4-28A, Appendix) not functioning.  Carriage return too slow.  Line feed adjustment incorrect.  Cable adjustments incorrect.  Incorrect number of turns on carriage return spiral spring.	Locate and correct malfunction.  Check for dirt on shafts.  Adjust according to paragraph 5-4e(11); make certain that the reference tooth (not the first tooth) on the line feed pawl (figure 4-28A, Appendix) is used when making this adjustment.  Adjust according to paragraph 5-4e(3)(c).  Refer to paragraph 5-4e(9).

TABLE 4-4. SYSTEM TROUBLE-SHOOTING CHART (Cont.)

SYMPTOM	PROBABLE CAUSE	CORRECTIVE ACTION
38. No ribbon reversal.	No eyelets in ribbon.	Replace ribbon.
	Ribbon improperly threaded.	Install ribbon according to paragraph 3-3c(2).
	Ribbon feed clutch does not release.	Locate and correct malfunction.
39. Unusual noise.	Clutch backstops out of adjustment.	Adjust backstops according to paragraph 5-4e(1).
	Interference between motor fan and outlet duct assembly (figure 5-72, Appendix).	Reposition motor to eliminate interference.
	Binding component.	Locate and correct.
	Incorrect idler gear adjustment.	Refer to paragraph 2-10.
	Defective clutch backstop spring.	Replace spring.
	Gears require lubrication.	Refer to table 5-9 (Appendix).
	Defective gear.	Check all gears for damage; replace defective gears.
40. Teletypewriter Set is polarity sensitive.	Defective bearings on gears.	Check and replace defective bearings.
	Defective bridge diode in line sensor.	Refer to Table 4-6, for line sensor trouble shooting, symptom 5.

TABLE 4-5. KEYBOARD 1A9, TROUBLE-SHOOTING CHART

TEST POINT	SYMPTOM	PROBABLE CAUSE	CORRECTIVE ACTION
<p>Ⓐ</p> <p>Ⓐ<sub>1</sub></p> <p>Ⓐ<sub>2</sub></p> <p>Ⓐ<sub>3</sub></p> <p>Figure 4-9 (Appendix)</p>	1. Teletypewriter set runs open with keyboard in operating position.	Keyboard slip connector contact or contact block not making correct contact.	Check for defective contacts; repair or replace defective contacts.
		Defective filter FL1; defective code pulsing contacts; defective master pulsing contacts; or defective BREAK switch.	Remove keyboard; connect multimeter across ●A; if reading is not 5 ohms, connect multimeter across ●A <sub>1</sub> and then across ●A <sub>2</sub> . If either reading is not 2.5 ohms, replace filter FL1. If readings at ●A <sub>1</sub> and ●A <sub>2</sub> are both 2.5 ohms, connect multimeter across ●A <sub>3</sub> . If no continuity, replace BREAK switch. If continuity is obtained across ●A <sub>3</sub> , adjust or repair code pulsing or master pulsing contacts for reading of 5 ohms across ●A.

TABLE 4-5. KEYBOARD 1A9, TROUBLE-SHOOTING CHART (Cont.)

TEST POINT	SYMPTOM	PROBABLE CAUSE	CORRECTIVE ACTION
	2. Teletypewriter set runs closed with keyboard in operating position.	SEND●REC-REC switch in wrong position or defective.  Master pulsing contacts or code pulsing contacts defective or out of adjustment (figure 4-7, Appendix).  Defective pulsing finger (figure 4-7, Appendix).  Defective filter FL1.	Set switch in correct position or replace switch.  Adjust according to paragraph 5-5ba or replace contacts.  Replace pulsing finger.  Refer to Symptom 1 for procedure.
	3. Incorrectly transmitted character.	Incorrect range adjustment.  Master pulsing contacts defective or out of adjustment.	Adjust according to paragraph 2-8e(1).  Adjust according to paragraphs 5-4e(25)(i) and 5-4e(27)(b) or replace contacts.
	4. Depressing BREAK switch does not open signal line.	Defective BREAK switch.	Refer to Symptom 1 for procedure.

TABLE 4-6. LINE SENSOR 1A3, TROUBLE-SHOOTING CHART





TEST POINT	SYMPTOM	PROBABLE CAUSE	CORRECTIVE ACTION
 Figure 4-13 (Appendix)	1. Printer runs open.	No signal input at ★2.	Connect multimeter (d-c volts) across ★2 (equipment energized; polarity of voltage determined by input signal line polarity) and check for 9 vdc with 60-ma signal and steady mark. If reading is correct, check resistor A2R1, diodes A2CR1 through A2CR5, or output of power supply as described below.
    Figure 4-13 (Appendix)		Incorrect power supply output.	Connect multimeter (a-c volts) across ★3 and check for 115 vac. If reading is incorrect, refer to table 4-10 (Appendix). Connect multimeter across ●D. If 33 vac is not obtained, check for defective transformer T1 or diodes A1CR1 through A1CR4. Connect multimeter (d-c volts) across ●E (negative) and ●F (positive). If 26 vdc is not obtained, check for defective diodes A1CR1 through A1CR4, capacitors A1C1 and A1C2, or resistors A1R1 and A1R2.

TABLE 4-6. LINE SENSOR 1A3, TROUBLE-SHOOTING CHART (Cont.)

TEST POINT	SYMPTOM	PROBABLE CAUSE	CORRECTIVE ACTION
<p>Ⓒ</p> <p>Ⓓ</p> <p>Figure 4-13 (Appendix)</p>	1. Printer runs open (Cont.).	Defective transistor circuit.	Connect multimeter (d-c volts) between ●F (positive) and ●G (negative). Check for -0.94 vdc during mark and -6.20 vdc during space (with BREAK switch depressed); then connect multimeter between ●F (positive) and ●H (negative) and check for -6.70 vdc during mark and -0.94 vdc during space. If readings are incorrect, check selector coils, transistors A2Q1 through A2Q3, and associated circuits. Refer to table 4-11 (Appendix) for complete voltage and current readings.
	2. Printer runs closed but does not print.	Same as Symptom 1.	Same as Symptom 1.
	3. Equipment prints garbled message or occasional misprint.	Same as Symptom 1.	Same as Symptom 1.
	4. Motor stop relay 1A1K1 continuously energized or will not energize.	Same as Symptom 1.	Same as Symptom 1.
	5. Reversing signal line leads makes equipment run open. Replacing leads in original position permits normal operation.	Defective or shorted bridge diodes CR1, CR2, CR3, or CR4.	Make individual continuity checks of diodes CR1 through CR4 and replace defective diode or repair short. Refer to figure 5-110.

TABLE 4-7. FUNCTION AND PULSE DATA

FUNCTION	MARKING PULSES					RESULTS
	1	2	3	4	5	
Blank						Suppresses printing and character advance.
Space			X			Suppresses printing only.
Line Feed		X				Suppresses printing and character advance. Releases line feed clutch on function main shaft.
Figures	X	X		X	X	Suppresses printing and character advance. Rotates letters figures clutch on function main shaft to figures position if it was previously held in letters position.
Bell -	X		X			Suppresses printing and character advance. Moves bell clapper. Operates only during figures shift.
Letters	X	X	X	X	X	Suppresses printing and character advance. Rotates letters figures clutch on function main shaft to letters position if it was previously held in figures position.
Carriage Return				X		Suppresses printing and character advance. Releases carriage return clutch on function main shaft.

TABLE 4-8. PRINTER 1A2, TROUBLE-SHOOTING CHART

TEST POINT	SYMPTOM	PROBABLE CAUSE	CORRECTIVE ACTION
<p>①</p> <p>Figure 4-34 (Appendix)</p>	1. Motor does not operate.	Absence of input power.	Turn equipment off. Gain access to motor. Remove connector from jack 1AJ11 (test point ★1) and turn equipment on. Connect a-c multimeter between 1AJ11-A and 1AJ11-B and read 115 vac. If reading is incorrect, refer to table 4-10 (Appendix). If readings are correct, continue with Symptom 2.
<p>Ⓑ</p> <p>Figure 4-34 (Appendix)</p>	2. Motor does not operate; input power present.	Defective motor or faulty connections.	Turn equipment off. For the 60-cps motor, connect multimeter (ohms) between A2P1-B and A2P1-A (47 ohms) and between A2P1-B and A2P1-D (140 ohms). For the 400-cps motor, check for 8.5 ohms between A2P1-A and A2P1-B and 19 ohms between A2P1-A and A2P1-D. If readings are incorrect, check for faulty connections or replace defective motor.
<p>Ⓒ</p> <p>Figure 4-34 (Appendix)</p>	3. Printer runs open.	Magnetic selector not plugged in or defective.	Make certain that magnetic selector connector is secure in jack 1A3J1. If trouble persists, turn equipment off, remove connector, and connect multimeter (ohms) between A1P1-B and A1P1-D; meter should read 65 ohms ±10%. Check between A1P1-C and A1P1-D for same reading. If either reading is incorrect, check for broken connection or replace magnetic selector.
<p>Ⓒ</p> <p>Figure 4-34 (Appendix)</p>	4. Printer runs closed. 5. Motor will not stop with figures H or time delay motor stop function.	Same as Symptom 3. Defective stop switch 1A2S1.	Same as Symptom 3. Turn off equipment. Connect multimeter (ohms) between 1A2P1-F and 1A2P1-H; actuate stop switch and check for continuity reading. If no continuity, replace stop switch.
	6. Refer to table 4-4 (Appendix) for other symptoms of trouble in printer.	Refer to table 4-4 (Appendix).	Refer to table 4-4 (Appendix).

TABLE 4-9. SIGNAL LINE POWER SUPPLY 1A4, TROUBLE-SHOOTING CHART

TEST POINT	SYMPTOM	PROBABLE CAUSE	CORRECTIVE ACTION
<p>③</p> <p>Ⓓ</p> <p>Ⓔ</p> <p>Ⓕ</p> <p>Figure 4-36 (Appendix)</p>	1. Printer runs open.	Incorrect signal line power supply output.	Refer to Symptom 1 of table 4-6 (Appendix).
	2. Equipment prints garbled message.	Incorrect or fluctuating output of signal line power supply.	Perform checks of Symptom 1 above; carefully check all components for signs of intermittent operation. Replace any suspect part with a good unit.

TABLE 4-10. ELECTRICAL CHASSIS 1A1, TROUBLE-SHOOTING CHART

TEST POINT	SYMPTOM	PROBABLE CAUSE	CORRECTIVE ACTION
<p>◆4</p> <p>through</p> <p>◆7</p> <p>Figure 4-37 (Appendix)</p>	<p>1. Printer motor, line sensor, or signal line power supply inoperative due to loss of input primary power.</p>	<p>Defective parts in primary power circuit.</p>	<p>Connect multimeter across ★4 (pins J9-1 and J9-2) and then across ★5 (pins J10-1 and J10-2); check for 115 vac at both test points. Check fuses F1, F2 and F3 and MOTOR switch S1 if readings are incorrect. If components are not defective, check power inputs at ★6, ★7, and service cable connections.</p>
<p>Ⓢ</p> <p>Figure 4-37 (Appendix)</p>	<p>2. Motor will not stop with figures H function, or time delay motor stop function.</p>	<p>Defective coil on motor stop relay K1.</p>	<p>With power off, connect multimeter (ohms) across ●I; if meter reads very high resistance (1 megohm or above), replace relay.</p>
<p>Ⓝ</p> <p>Ⓚ</p> <p>Ⓛ</p> <p>Figure 4-37 (Appendix)</p>	<p>3. Printer motor inoperative.</p>	<p>Defective capacitor C1.</p>	<p>With power off, connect multimeter between ●J and ●K and then between ●K and ●L; meter should read very high (1 megohm or above) or infinite resistance. If not, replace C1. To check for an open capacitor C1, replace with a known good capacitor. Check F2, and replace if defective.</p>
<p>Ⓜ</p> <p>Figure 4-37 (Appendix)</p>	<p>4. Heating element inoperative.</p>	<p>Defective fuse F2.</p> <p>Defective fuse F1 (AN/TGC-14(V) or fuse F1 or F4 (AN/TGC-14A(V)).</p> <p>Defective element or thermostat.</p>	<p>Replace fuse.</p> <p>Replace fuse.</p> <p>With power off, connect multimeter (ohms) across ●M (E1 to E2). Meter should read 66.5 ohms ±10%. Check that thermostat S3 opens at approximately +16°C (+60°F) and closes at approximately +5°C (+40°F). Replace defective heater or thermostat.</p>
<p>◆8</p> <p>Figure 4-37 (Appendix)</p>	<p>5. No output on send line.</p>	<p>Defective fuse F5 (AN/TGC-14A(V)) or F4 (AN/TGC-14(V)), defective keyboard, or incorrect option patching.</p>	<p>With power off, check fuse with multimeter (ohms); replace defective fuse. Refer to table 4-5 (Appendix) for keyboard troubleshooting. Check for correct option patching (paragraph 2-9).</p>
<p>◆9</p> <p>Figure 4-37 (Appendix)</p>	<p>6. Line sensor inoperative.</p>	<p>Loss of input signal.</p>	<p>Check for presence of input signal at ★9. If signal is missing, check service cable and junction box for defect or check for correct option patching (paragraph 2-9).</p>
	<p>7. No Signal Line Current when teletypewriter set is patched for Half-Duplex, Battery supplied internally.</p>	<p>Fuse F5 blown.</p> <p>AN TGC-14A(V) F4 AN/TGC-14(V), Signal Line Current Potentiometer (R2) Faulty.</p> <p>Faulty Signal Line Power Supply.</p>	<p>Replace</p> <p>Check continuity across line potentiometer (R2). Replace if there is no continuity.</p> <p>Check Signal Line Power Supply Table 4-9.</p>

TABLE 4-10A. TRANSMITTER CONTROL CIRCUITRY TROUBLE-SHOOTING

SYMPTOM	PROBABLE CAUSE	CORRECTIVE ACTION
<p>1. Remote Transmitter not being keyed when Send. Rec-Rec switch of keyboard set in the Send. Rec. position and Key-board in the operating position.</p>	<p>1. Malfunction or faulty wiring between XMTR Control terminals of junction box and remote transmitter.</p>	<p>Remove external wire and short them together.</p> <p style="text-align: center;">CAUTION</p> <p style="text-align: center;">115 VAC present.</p> <p>If transmitter does not key, trouble is either loose connection or no source of battery to key relay. If the transmitter keys, go to step #2.</p>
	<p>2. Malfunction or faulty wiring between XMTR terminals of the junction box and Send. Rec switch of Teletype-writer Set.</p>	<p>Place Send. Rec switch in Send. Rec position and check for continuity across XMTR terminals. If continuity reading is not obtained, proceed to step #3.</p>
	<p>3. Loose wiring between cable connector pins and XMTR terminals. (Refer to figure 5-113, Appendix, alternate Service Cable 1A10.)</p>	<p>Remove connector from chassis. Check for continuity between L and E8 and M and E9. If continuity is obtained, proceed to step #4.</p>
	<p>4. Faulty chassis connector receptacle (refer to figure 5-113, Appendix).</p>	<p>Set Send. Rec-Rec switch in Send. REC position and check for continuity across pins L and M of chassis receptacle (J8). If no reading is obtained, check for loose wiring. If wiring and receptacle check out, proceed to step #5.</p>
	<p>5. Loose wire between contacts 2 and 5 of connector block of chassis and L and M of receptacle (J8).</p>	<p>Remove keyboard from chassis. Check for continuity between L of J8 and #2 contact of contact block and M of J8 and #5 contact of contact block. If continuity is not obtained in either reading check for loose connection or cold solder joint. If continuity is obtained proceed to step #6.</p>
	<p>6. Faulty contacts in Send. Rec-Rec switch (S3) or loose wire between switch and slip contacts of the keyboard.</p>	<p>Check for continuity across transient contacts #3 and #4 of keyboard with switch in Send. Rec position. If continuity is not obtained, check across terminals of switch. If reading is not obtained, replace the switch. If reading is obtained, check for loose wiring between switch and slip contacts.</p>
	<p>7. Faulty contact block, contacts.</p>	<p>Replace keyboard and set Send. Rec-Rec switch in Send. Rec position. Connect service cable to chassis and check for continuity across XMTR Control binding posts. If no reading is obtained check contact block 1A1E8 and keyboard slip connector contacts 1A9E1. Bend keyboard slip connector contacts 3 and 4 slightly upward and recheck for continuity across XMTR control binding posts. Replace contact block (1A1E8) if necessary.</p>
<p>2. Inadvertant keying of Local Transmitter.</p>	<p>Faulty RF filter in Service Cable "J" box.</p>	<p>Check capacitors.</p>



TABLE 4-11. VOLTAGE AND CURRENT MEASUREMENTS

TEST CONDITIONS (Connect negative lead of meter to electrical chassis, unless otherwise indicated.)	TRAN- SISTOR	BASE		EMITTER		COLLECTOR	
		D-C VOLTS	D-C MA	D-C VOLTS	D-C MA	D-C VOLTS	D-C MA
LINE SENSOR 1A3							
1. Connect strap (figure 4-13, Appendix) across A2E2 and A2E3; apply primary power at 115 vac, 60 cps; use Multimeter AN/PSM-4, or equivalent; apply mark signal at 60 ma; check for -5.5 vdc at A2E14.	A2Q1	-1.70	1.90	-1.42	11.0	-1.46	8.80
	A2Q2	-1.40	6.90	-0.84	94.0	-0.94	87.0
	A2Q3	-0.47	0	-0.84	0	-6.70	0
2. Same as condition 1 except mark signal at 20 ma and -1.85 vdc at A2E14. Check for 29.1 vdc between A2E6 and A2E13 and 33 vac rms between TI-3 and TI-4.	A2Q1	-1.55	0.15	-1.35	8.60	-1.47	8.40
	A2Q2	-1.35	4.80	-0.83	88.0	-0.93	86.0
	A2Q3	-0.48	0	-0.84	0	-6.80	0
3. Same as condition 2 except apply space signal at 0 ma.	A2Q1	0	0	-0.41	0	-16.50	0
	A2Q2	-0.41	0	-0.82	0	6.20	0
	A2Q3	-0.49	0	-0.88	93.0	-0.94	89.0
4. Connect strap (figure 4-13, Appendix) across A2E1 and A2E2; apply primary power at 115 vac, 60 cps; use Multimeter AN/PSM-4, or equivalent; apply mark signal at 5 ma; check for -11.3 vdc at A2E14.	A2Q1	-1.75	4.80	-1.55	13.60	-1.90	8.80
	A2Q2	-1.55	9.70	-0.88	97.0	-0.97	88.0
	A2Q3	-0.49	0	-0.88	0	-7.0	0
5. Same as condition 4 except apply mark signal at 1 ma.	A2Q1	-1.65	0.98	-1.40	10.0	-1.44	9.0
	A2Q2	-1.40	6.40	-0.86	95.0	-0.95	89.0
	A2Q3	-0.47	0	-0.86	0	-7.0	0
6. Same as condition 4 except apply space signal at 0 ma; also check for -5.95 vdc at A2E10 and 0.45 vdc across resistor A2R9.	A2Q1	-0.59		-0.52		-16.80	
	A2Q2	-0.52		-0.86		-6.60	
	A2Q3	-1.20		-0.85		-0.96	

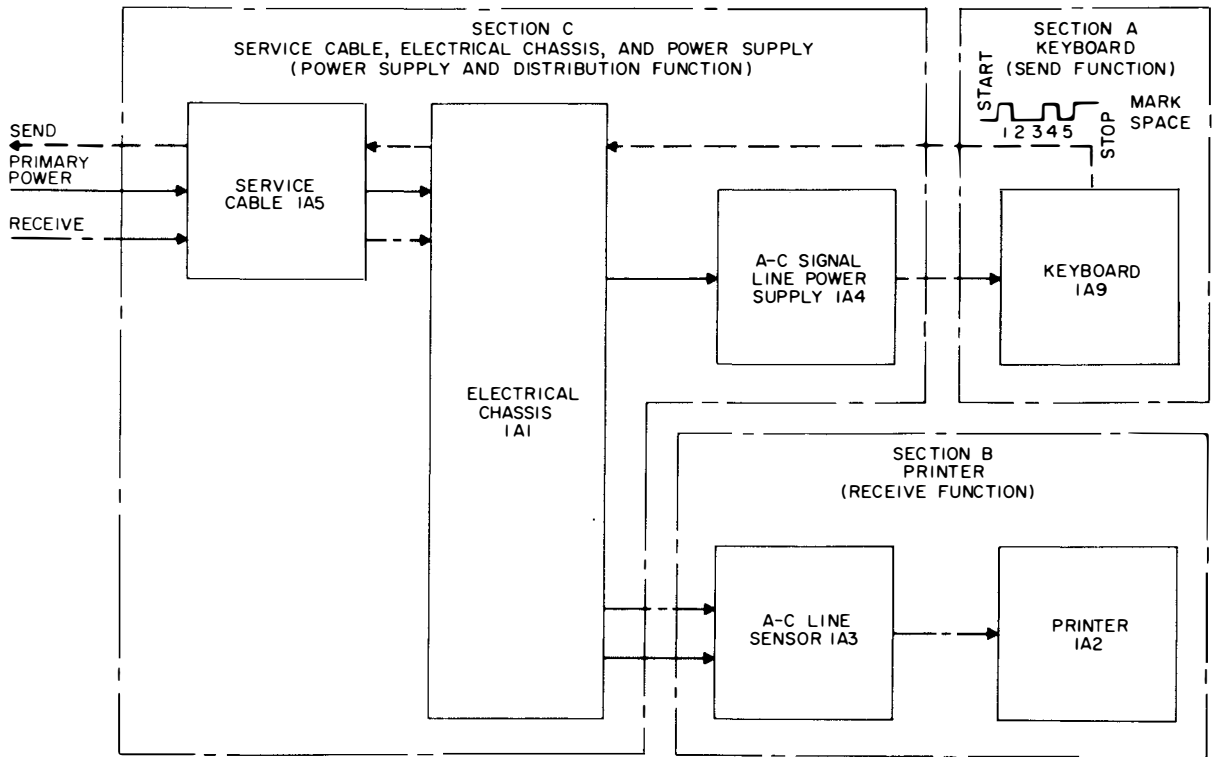

Figure 4-1. Functional Sections

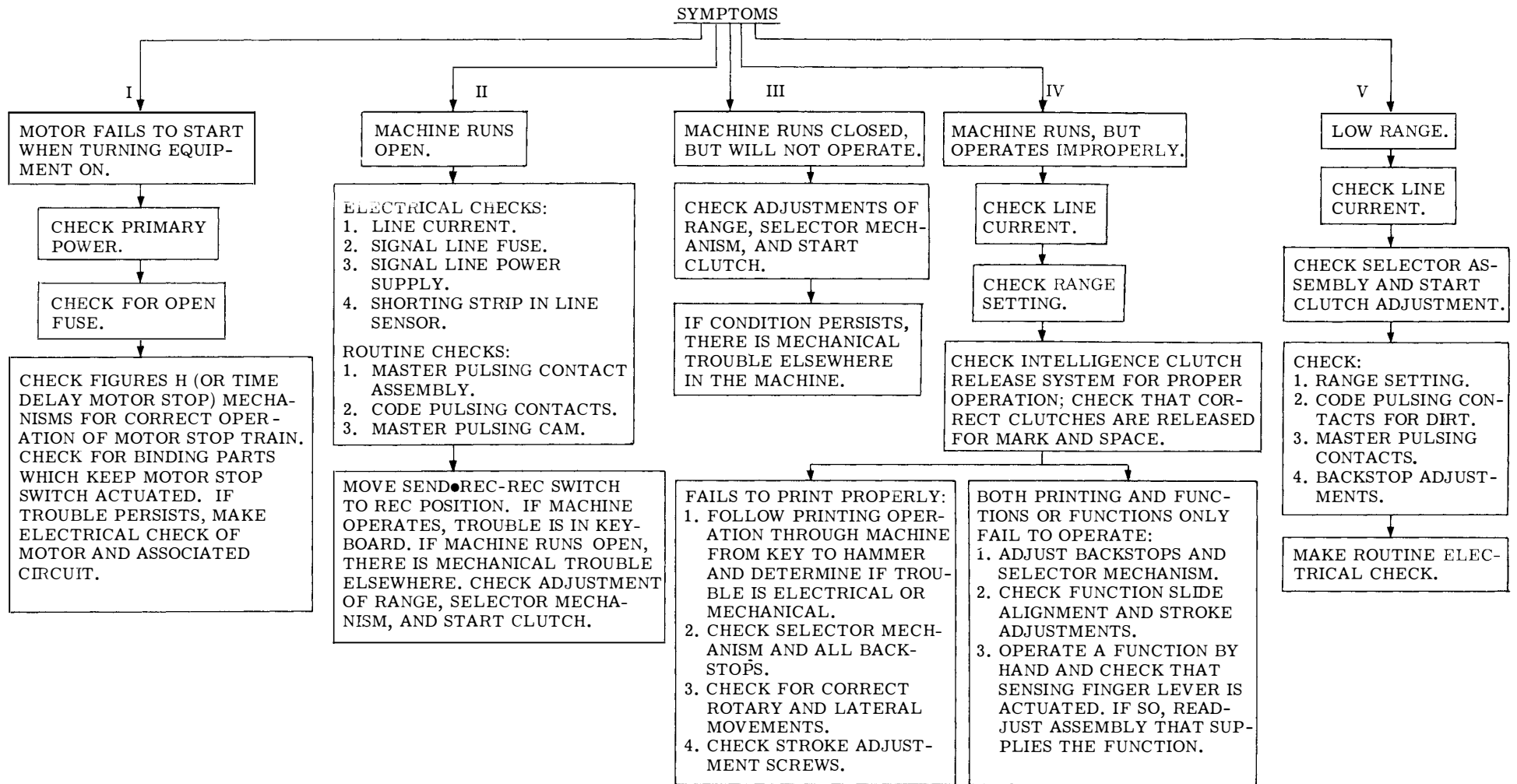

Figure 4-5. Trouble-Shooting Flow Chart

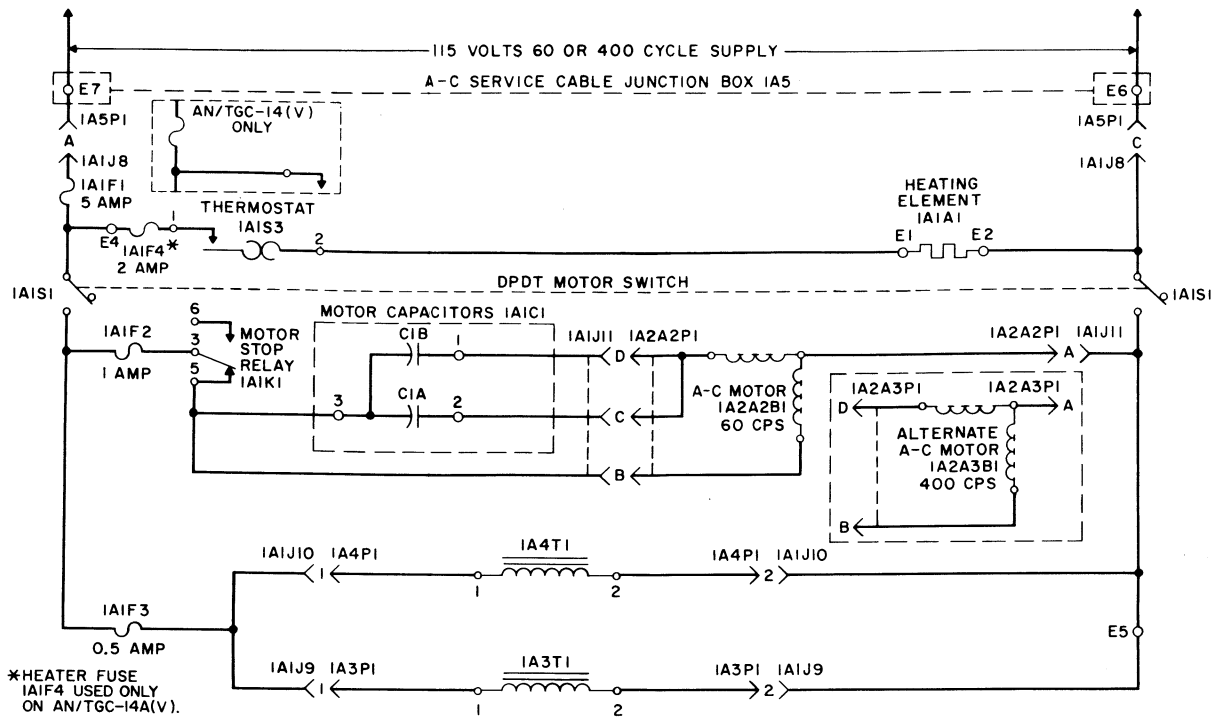

Figure 4-6. Alternating Current Primary Power Distribution, Simplified Schematic Diagram

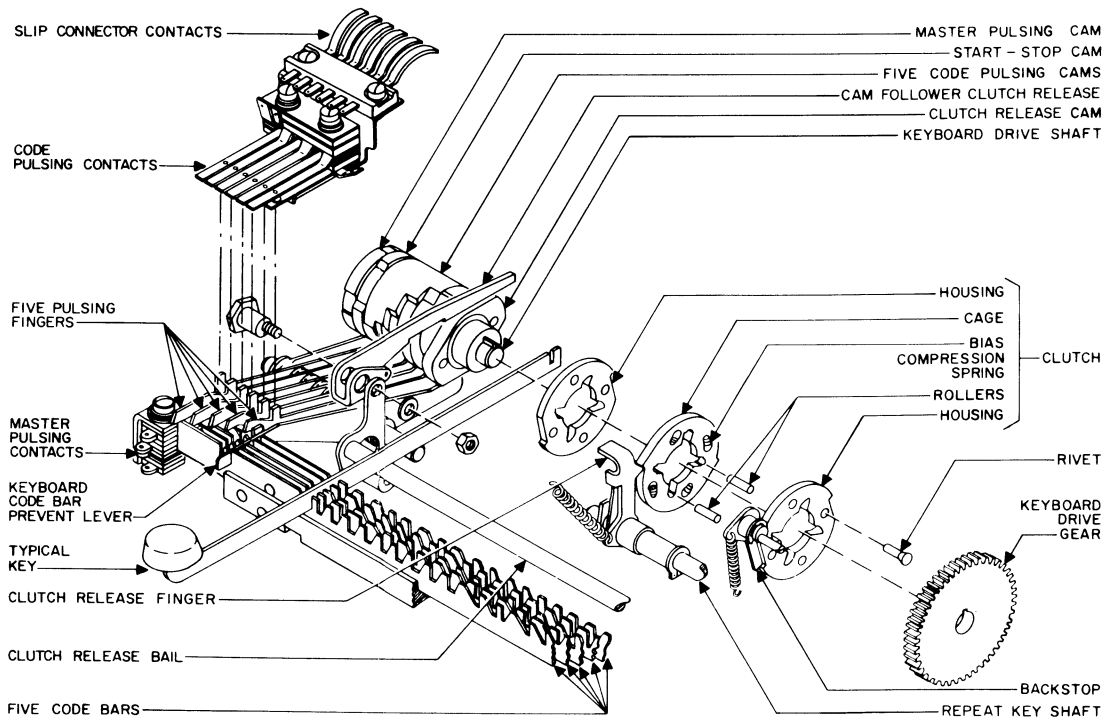

Figure 4-7. Keyboard 1A9, Mechanical Diagram

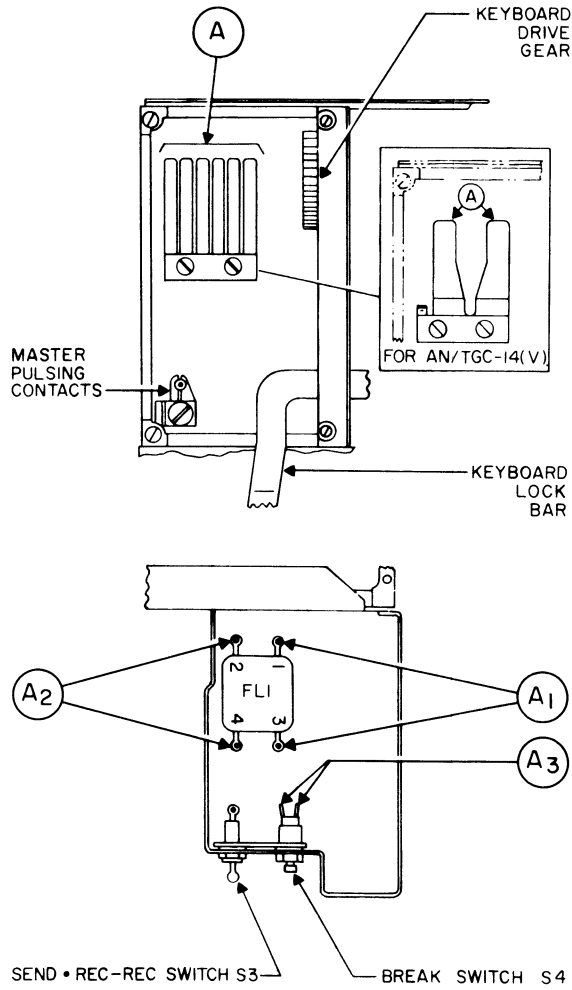

Figure 4-9. Keyboard 1A9, Location of Test Points

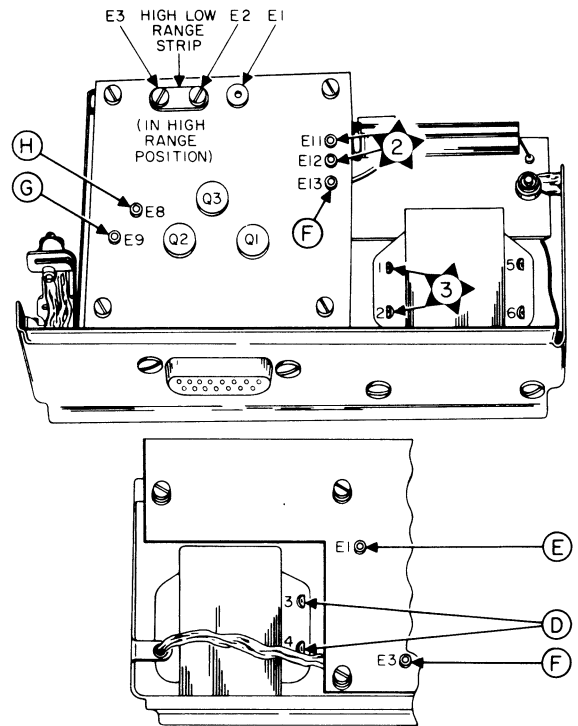

Figure 4-13. Line Sensor 1A3,  
Location of Test Points

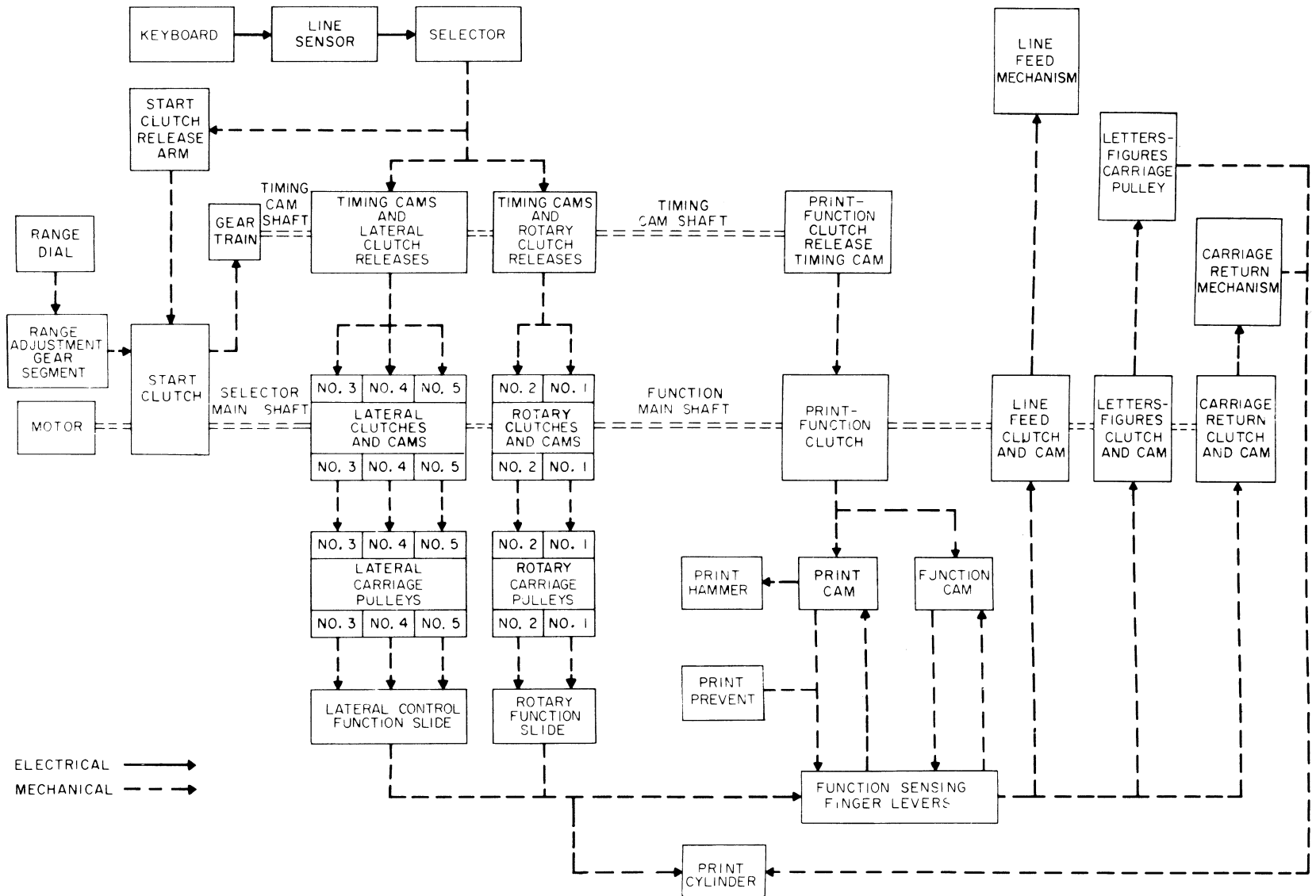

Figure 4-14. Printer 1A2, Functional Block Diagram



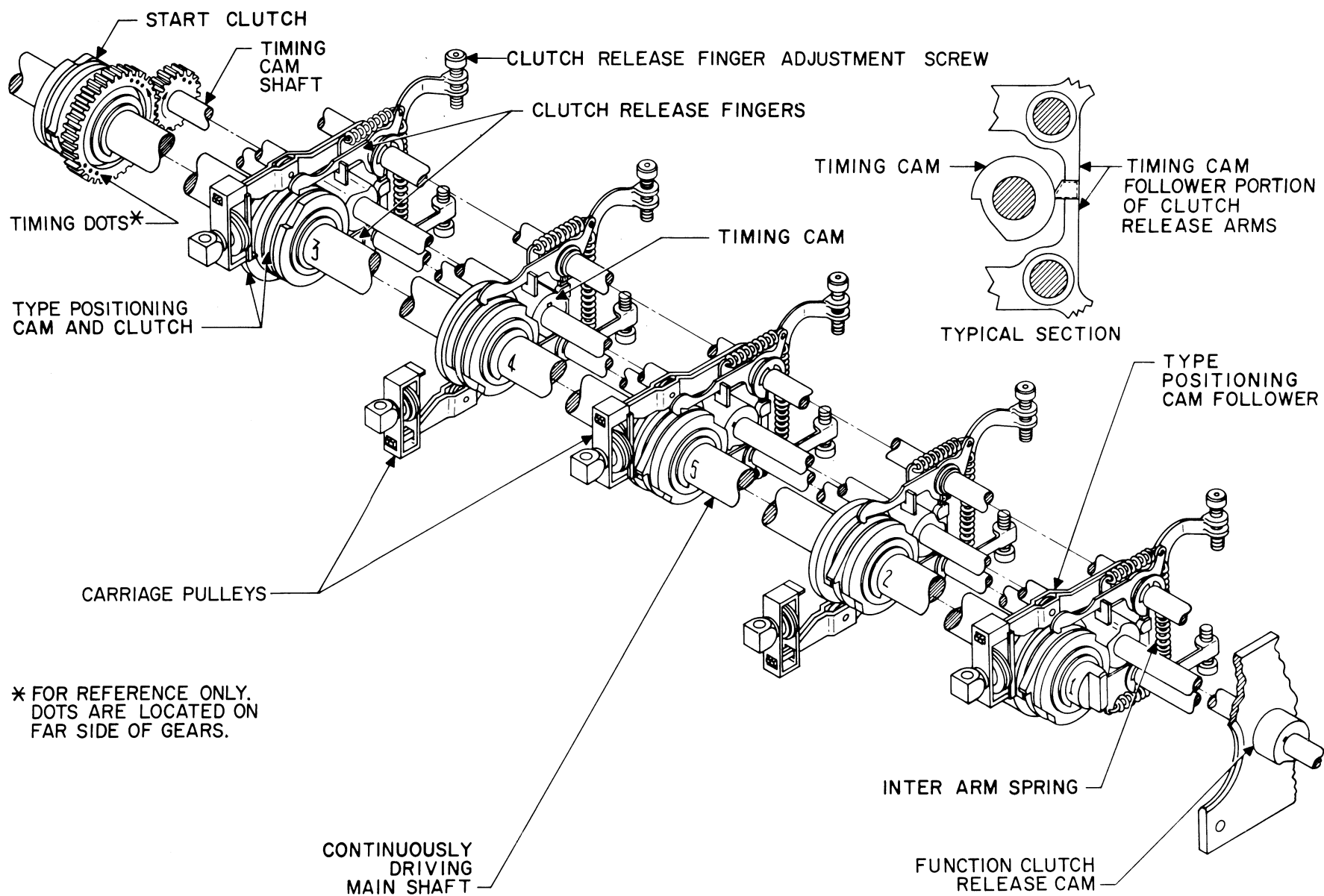

Figure 4-22. Print Cylinder Positioning Clutch Release System



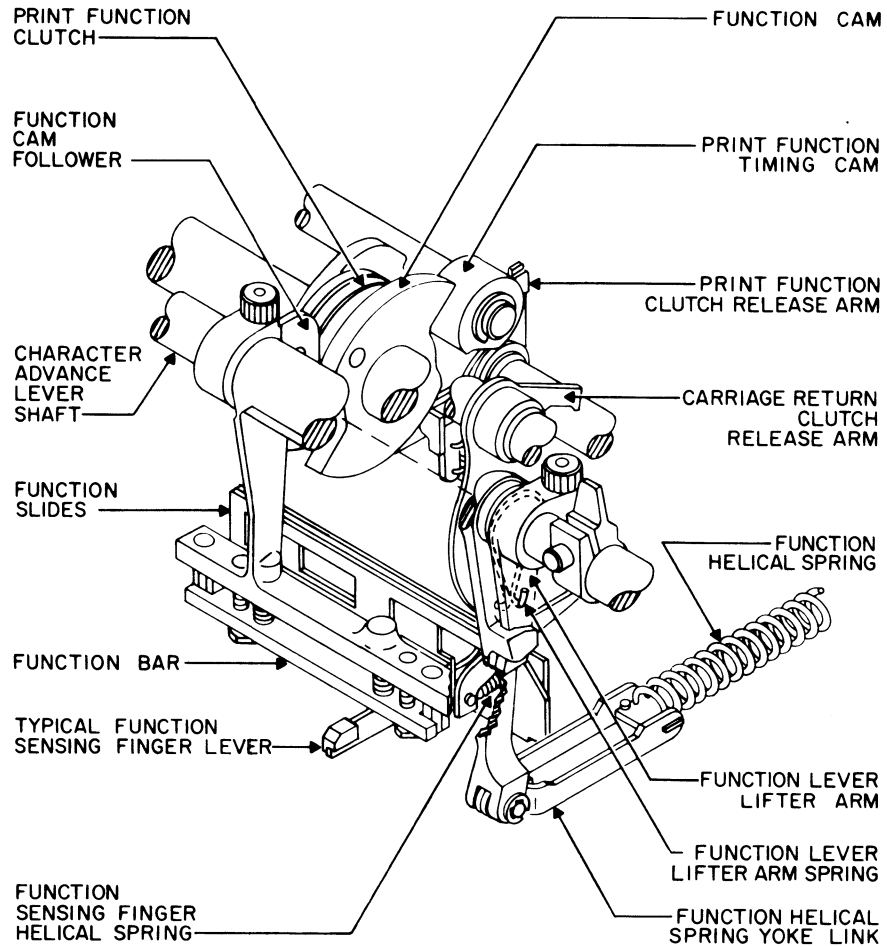

Figure 4-24. Function Selector, Start of Function Cycle

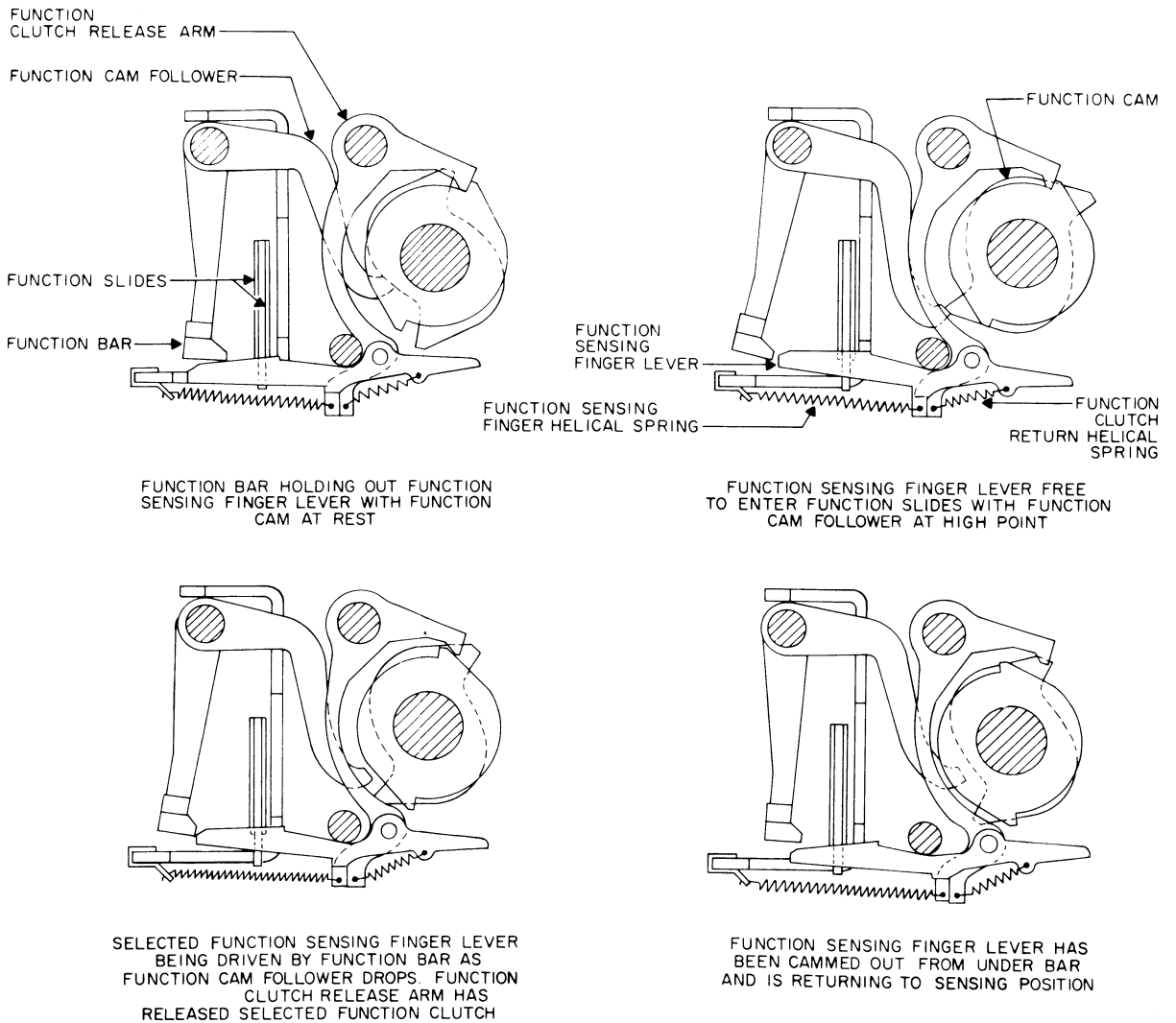

Figure 4-25. Function Selector, Operating Cycle

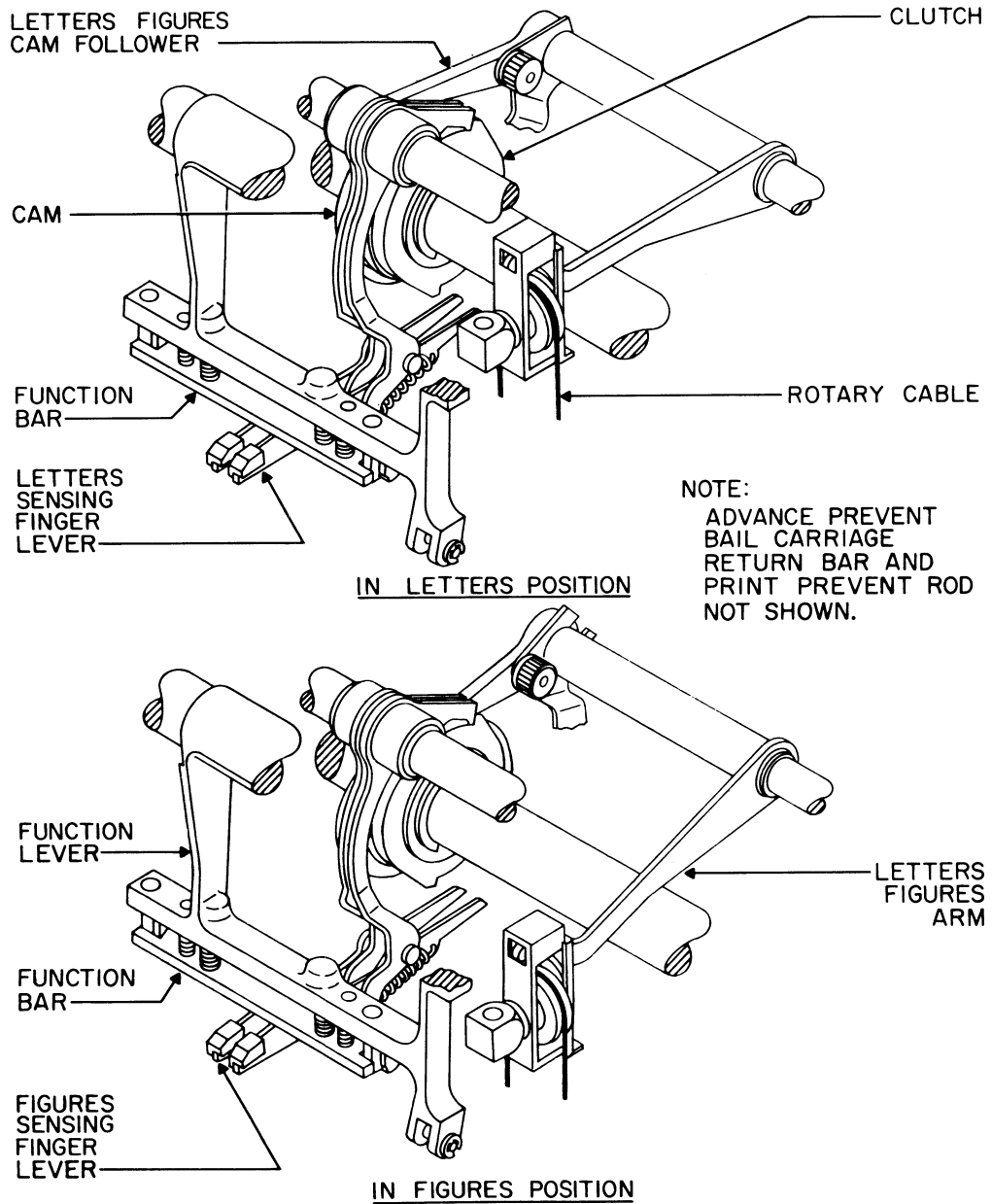

Figure 4-28. Function Selector, Letters Figures Linkage

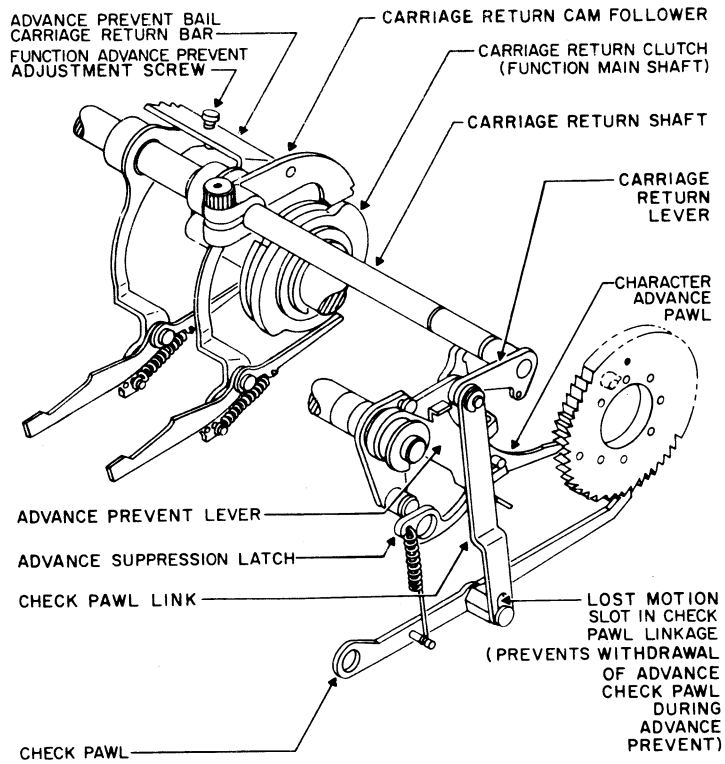

Figure 4-31. Function Selector, Character Advance Prevent Linkage

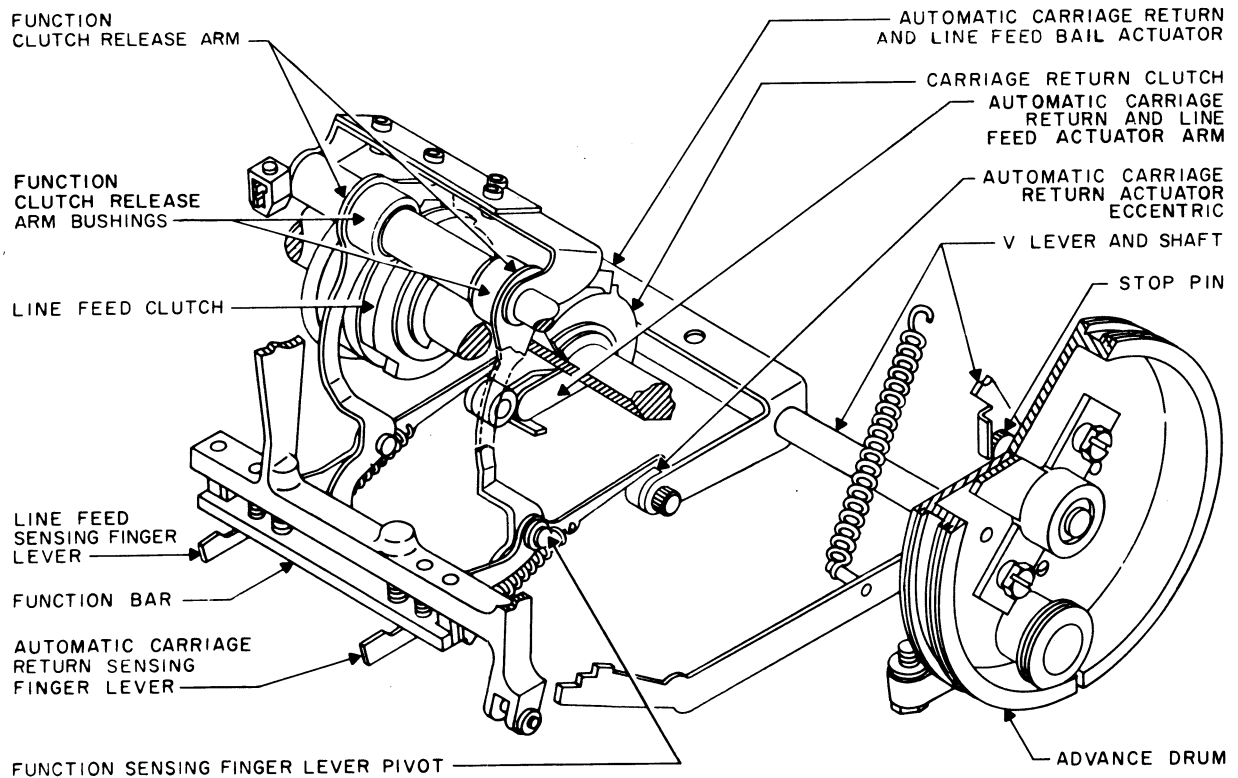

Figure 4-31A. Automatic Carriage Return and Line Feed Linkage

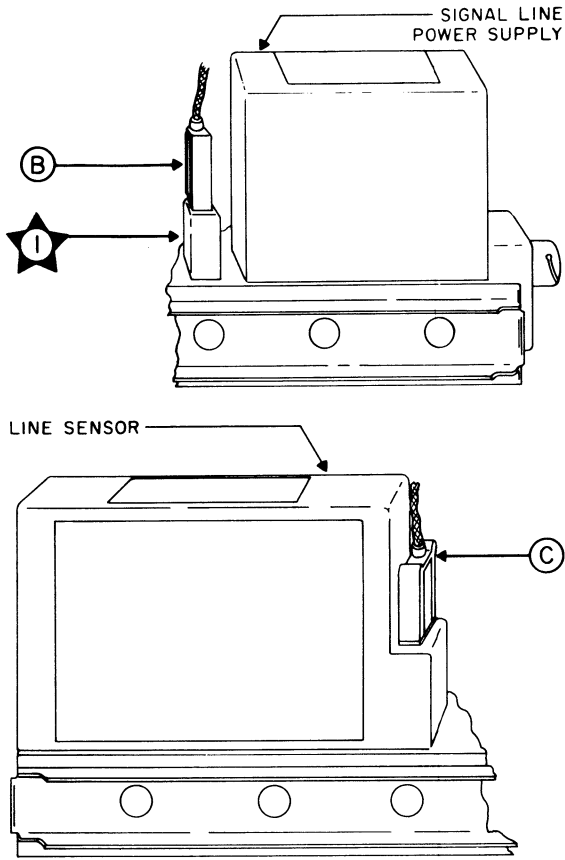

Figure 4-34. Printer 1A2,  
Location of Test Points

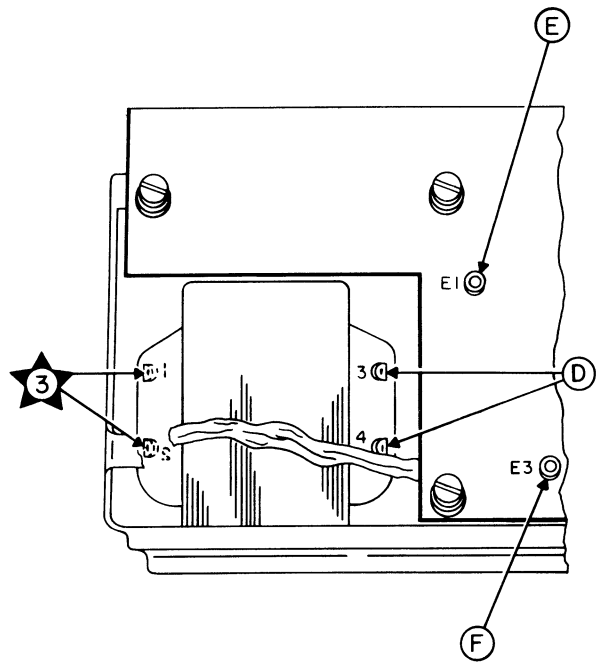

Figure 4-36. Signal Line Power Supply 1A4,  
Location of Test Points

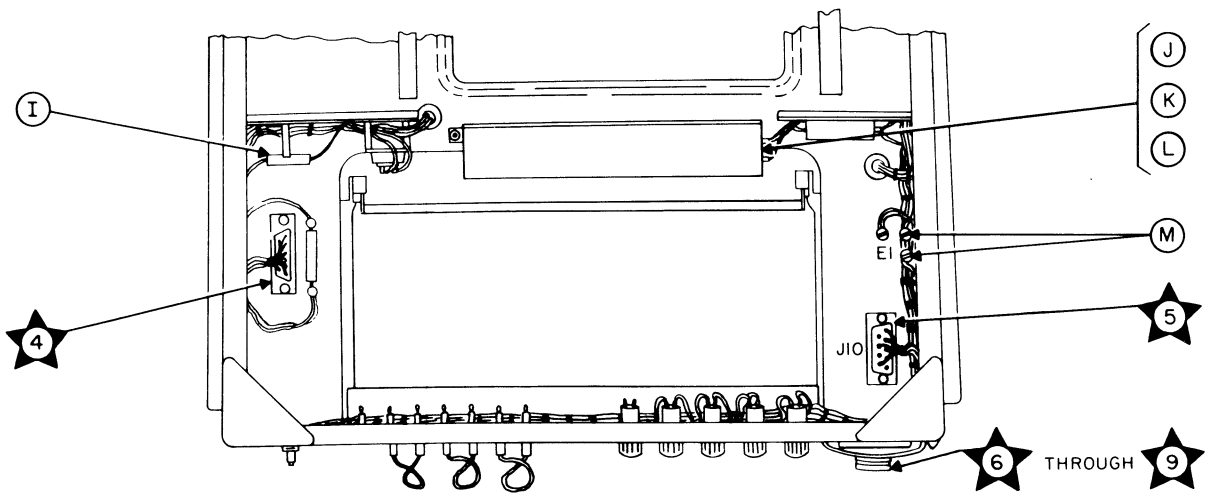

Figure 4-37. Electrical Chassis 1A1, Location of Test Points

TABLE 5-1. TEST EQUIPMENT AND TOOLS REQUIRED

TEST EQUIPMENT AND TOOLS	PREVENTIVE MAINTENANCE	MAINTENANCE STANDARDS	REPAIR
Multimeter AN/PSM-4	X	X	
Electronic Multimeter TS-505/U			X
Oscilloscope AN/USM-24 or AN/USM-105			X
*Teletypewriter Tool Kit TK-122/U			X
Materials			
Oil, Non-fluid			
MITE Part No. 34303			
1-pint plastic bottle			
FSN 5815-869-9148			
Grease			
MITE Part No. 05041-0001			
8 ounce tube			
FSN 9150-261-8297			

\*This tool kit contains all required special tools and gages.

TABLE 5-2. OPERATOR'S DAILY CHECKOFF LIST

STEP NO.	ACTION REQUIRED	PROCEDURE
1	<p>Operating conditions and control settings:                      MOTOR and LAMP switches: ON                      SEND●REC-REC switch: SEND-REC                      Equipment patched for off-line local mode (paragraph 2-9).                      Refer to Section 3 for operating instructions.</p> <p>Test overall operation of teletypewriter set with Keyboard in operating position.</p>	<p>A. Depress LTRS key and type out test message. Observe that machine prints clearly with no garbles.</p> <p>B. On AN/TGC-14(V), depress FIGS key and then depress STOP key; observe that motor stops. On AN/TGC-14A(V), observe that motor stops after 60 to 90 seconds (75 baud and 45.45 baud respectively) of inactivity with time delay MOTOR STOP switch in ENABLE position.</p> <p>C. Depress BREAK button. Observe that motor starts.</p> <p>D. Type out a complete row of characters and observe that automatic carriage return and line feed take place after 72 or 76 characters have been printed.</p> <p>E. Test all off line function buttons on the printer front cover for proper operation.</p> <p>F. Operate all other controls and check for binding or improper operation.</p> <p>G. Set SEND●REC-REC switch to REC position. Arrange to have test sentence sent from a remote station. Operate local keyboard and observe that received message is clear and correct. This indicates that the SEND●REC-REC switch is operating correctly.</p>

TABLE 5-3. OPERATOR'S WEEKLY CHECKOFF LIST

STEP NO.	ACTION REQUIRED	PROCEDURE
	Operating conditions and control settings: Primary power removed. Teletypewriter set removed from case.	
1	Inspect components.	Inspect cables and lateral control belt for wear. Inspect ribbon for dryness.
2	Clean mechanical parts.	Using a rag or brush, clean print hammer shaft and print cylinder and yoke shafts.
3	Clean and oil air filter.	Take out case air filter and dip in cleaning fluid (Federal Specification P-S-661). Blow dry using clean dry air or allow to air dry. Immerse in S.A.E. 30 oil and blow excess oil off while rotating filter.
4	Inspect all mechanical parts for security.	Remove paper guide; inspect ribbon feed mechanism and all other mechanical parts for binding or damage.
5	Inspect electrical cables.	Inspect service cable wiring and binding posts for damage.
6	Inspect electrical chassis rear panel.	Inspect option patch connections for security. Inspect fuse posts for security and damage.

TABLE 5-4. TECHNICIAN'S DAILY CHECKOFF

STEP NO.	ACTION REQUIRED	MAINTENANCE STANDARD REFERENCE NUMBER(Refer to Table 5-8, Appendix)
	Operating conditions and control settings: Primary power removed. Teletypewriter Set removed from case.	
1	Clean the teletypewriter set as required.	A9
2	Inspect teletypewriter set.	A10
3	Check paper supply.	A11
4	Lubricate (if necessary)	A12

TABLE 5-5. TECHNICIAN'S WEEKLY CHECKOFF

STEP NO.	ACTION REQUIRED	MAINTENANCE STANDARD REFERENCE NUMBER (Refer to Table 5-8, Appendix)
Operating conditions and control settings: Primary power removed (Steps 1 & 2) Primary power connected (Steps 3 through 8) Teletypewriter set removed from case (5-4b(3)). Equipment patched for Mode 1 (paragraph 2-9).		
1	Lubricate unit	A12
2	Slide alignment and takeup arm adjustment.	A1 - A2
3	Check selection of functions.	A17
4	Check range.	A8
5	Detent pin.	A3
6	Hammer alignment.	A4
7	Measure internal signal line current.	A20
8	Measure primary power source.	A24
9	Check cables and lateral control belt for wear.	A10

TABLE 5-6. TECHNICIAN'S MONTHLY CHECKOFF

STEP NO.	ACTION REQUIRED	MAINTENANCE STANDARD REFERENCE NUMBER (Refer to Table 5-8, Appendix)
Operating conditions and control settings: Primary power moved (Steps 2, 4, 5, and 6). Primary power connected (Steps 1, 3, and 7). Equipment patched for Mode 1 (paragraph 2-9). Teletypewriter set removed from case 5-4b(3).		
1	Motor Stop Check Time Delay Figures H	A7a A7b
2	Disassemble and inspect	A13
3	Check stroke	A5 - A6
4	Clean filter	A22
5	Clean and lubricate unit	A9 - A19
6	Inspect and check chassis	A18 - A20
7	Master pulsing contacts	A18



TABLE 5-7. TECHNICIAN'S QUARTERLY CHECKOFF

STEP NO.	ACTION REQUIRED	MAINTENANCE STANDARD REFERENCE NUMBER (Refer to Table 5-8, Appendix)
Operating conditions and control settings: Primary power removed (Steps 1, 2, 4, and 5). Primary power connected (Step 3). Equipment patched for Mode 1 (paragraph 2-9). Teletypewriter set removed from case (5-4b (3)).		
1	Clean selector assembly.	A14
2	Clean motor assembly.	A15
3	Adjustment checks.	A16
4	Shock mounts.	A23

TABLE 5-8. MAINTENANCE STANDARDS

REFERENCE NO.	MAINTENANCE STANDARDS	ADJUSTMENT PARAGRAPH NO.
NOTE  The following maintenance standards are keyed to the Technician's Checkoff Lists, tables 5-4 through 5-7 and to the related adjustment procedures.  CAUTION  Do not perform any adjustment sequence without first checking the adjustment to insure that the suspect adjustment is incorrect.		
A1	<b>SLIDE ADJUSTMENT</b>  Position the printer in letter A with the function clutch in the stop position.  Check for proper alignment of rotary and lateral slide index mark on the function selector frame.	5-4e(3)(b)  5-4e(4)(b)
A2	<b>TAKEUP ARM PULLEY AND TAKEUP DRUM</b>  Check for approximately 1/16 inch clearance between the O. D. 's of the takeup arm pulley and the takeup drum (in letters A).	5-4e(4)(a)
A3	<b>ROTARY DETENT PAWL PIN CLEARANCE</b>  Check that the detent pin clears the points of the index wheel by at least 0.010 inch when print function clutch is in stopped position.	5-4e(7)

TABLE 5-8. MAINTENANCE STANDARDS (Cont.)

REFERENCE NO.	MAINTENANCE STANDARDS	ADJUSTMENT PARAGRAPH NO.
A4	<p>HAMMER ALIGNMENT WITH "A"</p> <p>Position printer in letter "A". Check alignment of hammer with "A" halfway across line.</p>	5-4e(12)
A5	<p>ROTARY STROKE</p> <p>Check for rotary motion of print cylinder to the type strips containing the letters A, E, L, and T.</p>	5-4e(17)(a)
A6	<p>LATERAL STROKE</p> <p>Check for lateral alignment of print cylinder behind the hammer for the letters A, W, J, and U.</p>	5-4e(17)(b)
A7	MOTOR STOP	
A7a	<p>On AN/TGC-14A(V) check for motor shut down in approximately:</p> <p>60 sec. at 75 baud (No signal received) 90 sec. at 45.45 baud (No signal received)</p>	5-4e(23)(a)
A7b	<p>On AN/TGC-14(V), depress FIGS key and then depress STOP key; observe the motor stops.</p>	5-4e(23)(b)
A8	<p>RANGE OF PRINTER:</p> <p>Check for minimum of 70 points of range at 100 wpm. (AN/TGC-14(V) or 75 baud (AN/TGC-14A(V)))</p> <p>Hi - Low = points of range</p> <p>To find the points of range subtract the lowest point on the range dial where the signal can be accepted without errors from the highest point on the range dial where the signal can be accepted without errors. (Minimum points of range at 100 wpm should be 70 points).</p>	5-4e(2)(b)
A9	<p>CLEAN PRINTER UNIT</p> <p style="text-align: center;"><b>CAUTION</b></p> <p style="text-align: center;">Insure that springs and adjustable parts are not disturbed.</p> <p style="text-align: center;">Use a soft lint-free cloth and clean the cylinder, yoke, and hammer shafts. If exceptionally dirty apply a few drops of oil to the shafts while running and then wipe completely dry. Wipe off all dust, lint, and paper shavings. Special attention should be paid to the keyway in the print cylinder shaft.</p>	
A10	INSPECT PRINTER UNIT	
	<p style="text-align: center;"><b>CAUTION</b></p> <p style="text-align: center;">Never increase tension on print hammer for darker copy. Replace ribbon if darker copy is desired.</p> <p style="text-align: center;">Inspect ribbon for wear and frayed edges. Inspect cables for fraying, wear, or cuts.</p>	

TABLE 5-8. MAINTENANCE STANDARDS (Cont.)

REFERENCE NO.	MAINTENANCE STANDARDS	ADJUSTMENT PARAGRAPH NO.
<p><b>NOTE</b></p> <p>Check print hammer disconnect adjustment if ribbon replacement does not provide darker copy.</p>		
A11	<p><b>CHECK PAPER SUPPLY</b></p> <p>Insure that sufficient paper is on roll and that it is properly installed.</p>	
A12	<p><b>LUBRICATION</b></p>	
<p><b>CAUTION</b></p> <p>Never lubricate the cylinder, hammer or yoke shafts. (Refer to lubrication schedule).</p>		
A13	<p><b>DISASSEMBLE AND INSPECT PRINTER UNIT</b></p>	
<p><b>CAUTION</b></p> <p>Use only low pressure air to clean unit. Insure that springs are not disengaged or lost.</p>		
	<p>Disassemble printer unit into four major assemblies. Inspect for loose, broken, or worn parts. Clean off all excessive oil and grease. (Make a small diagram of timing mark alignment, before removing mainshaft from frame) Refer to figure 5-99, for location of timing marks only.</p>	5-4(g)
A13a	<p><b>INSPECT MAINSHAFT</b></p> <p>Clean off all excessive grease and oil from clutches and the area between the clutches. Check to insure that all cages move freely and relubricate with oil.</p>	
A13b	<p><b>REASSEMBLE PRINTER UNIT</b></p> <p>Replace all worn, broken, or missing parts as required. Check for proper alignment of timing marks on mainshaft and timing shaft when reassembling front and rear halves of printer. (Refer to timing mark diagram prepared during disassembly)</p>	
A14	<p><b>SELECTOR MECHANISM</b></p> <p>Remove the selector and clean in residue free solvent. Relubricate bearings and felts with oil, place one drop of oil on all carbide surfaces. Replace selector in printer.</p>	
A15	<p><b>MOTOR ASSEMBLY</b></p> <p>Remove motor and inspect first reduction gear and pinion gear for wear or damage. Lubricate gears with grease prior to reassembly.</p>	
<p><b>CAUTION</b></p> <p>Never remove gear head from 400 cycle motors.</p>		

TABLE 5-8. MAINTENANCE STANDARDS (Cont.)

REFERENCE NO.	MAINTENANCE STANDARDS	ADJUSTMENT PARAGRAPH NO.
A16	<p><b>CHECK ADJUSTMENTS</b></p> <p>The following adjustments should be checked and readjusted if necessary.</p> <ul style="list-style-type: none"> <li>a. Start Clutch Release</li> <li>b. Selector</li> <li>c. Rotary and Lateral Stroke</li> <li>d. First Character</li> <li>e. Character Advance</li> <li>f. Automatic CR &amp; LF</li> </ul>	<p>5-4e(5) 5-4e(16) 5-4e(17) 5-4e(21) 5-4e(8) 5-4e(9)b</p>
A17	<p><b>CHECK FOR PROPER OPERATION OF FUNCTIONS</b></p>	
<b>NOTE</b>		
<p>Check slide and stroke adjustment prior to checking individual function clutches and linkages, if functions do not operate.</p>		<p>5-4e(3)(b) 5-4e(4)(b) 5-4e(17)</p>
A18	<p>Blank                      Bell Space                      Letters Line Feed                  Carriage Return Figures</p> <p><b>MASTER PULSING CONTACTS</b></p> <p>Continuously transmit the letter "R" using the repeat key. This checks the upper contact screw adjustment. Continuously transmit the letter "Y" using the repeat key. This checks the lower contact screw adjustment.</p>	<p>5-4e(25)(i) or 5-4e(27)(b)</p>
A19	<p><b>KEYBOARD INSPECTION</b></p> <p>Inspect the keyboard for worn, broken or loose parts. Check for accumulation of dirt and grease. Clean keyboard with a lint-free cloth and relubricate using oil on all linkages and grease on gears.</p>	
A20	<p><b>INTERNAL LINE CURRENT</b></p> <p>Check internal line current for 20 to 80 ma settings (60 ma is average) in the high range and 2.5 ma in the low range.</p>	<p>5-4e(29)</p>
A21	<p><b>INSPECT CHASSIS</b></p> <p>Inspect the chassis for loose components and frayed or damaged wiring. Check for proper fuses and proper patching for mode of operation required. Wipe off all excess oil and grease on the chassis.</p>	
A22	<p><b>AIR FILTER</b></p> <p>Clean air filter as per printed instructions on the filter.</p>	
A23	<p><b>SHOCK MOUNT</b></p> <p>Inspect shock mount for security. Check to insure that no foreign matter is interfering with operation of the shock mount.</p>	
A24	<p><b>MEASURE PRIMARY POWER SOURCE</b></p> <p>Set Multimeter AN/PSM-4 to measure a-c voltage of 0 to 250 volts; connect leads across primary power source and check for correct primary power.</p>	

TABLE 5-9. LUBRICATION INSTRUCTIONS

FIGURE AND INDEX NO. (APPENDIX)	LUBRICATION OR CHECK POINT	SPECIAL INTERVAL	PERIODIC INTERVALS		
		ANY REASSEMBLY	EVERY 250 HOURS	EVERY 1000 HOURS	EVERY 3000 HOURS
PRINTER ASSEMBLY					
5-14	Clutch backstop lever surfaces where they meet clutches.	0	0		
5-21(8)	Stop tab on all clutches.	0	0		
5-29 (6)(5)	Tab on carriage return lock lever where it meets pin in lock lever actuator arm.	0		0	
5-29(13, view B)	Carriage return lock lever and carriage return cam follower at meeting point.	0	0		
5-43(8)	Print prevent arm where print prevent rod lever engages.	0	0		W
5-70(5)	Range adjustment gear segment (on start clutch assembly).	0			0
5-70(21)	Clutch and cam rollers.	0	0		
5-78(22, 45, 10, 36, 34, 20, 16, and 12)	All bushings (felts), letters figures cam follower assembly and line feed actuator assembly mounted on mark and space clutch release selector shafts running length of printer on which are mounted the mark and space clutch release assemblies and type positioning cam followers.	0		0	
5-80(6)	Print hammer actuator link guide bracket.	0			0
5-82(60)	Print hammer actuator link lever pivot.	0	0		
5-82 (35 and 35)	Right-hand and left-hand bearings.	0	0		
5-83 (13 and 14)	Paper feed detent roller and pivot on paper feed detent arm.	0	0		W
5-83(15)	Pressure roll shaft.	0	0		

TABLE 5-9. LUBRICATION INSTRUCTIONS (Cont.)

FIGURE AND INDEX NO. (APPENDIX)	LUBRICATION OR CHECK POINT	SPECIAL INTERVAL	PERIODIC INTERVALS		
		ANY REASSEMBLY	EVERY 250 HOURS	EVERY 1000 HOURS	EVERY 3000 HOURS
5-84(9)	Carriage return spiral spring.	0		0	
5-84(37)	Print cam follower tip.	0			W
5-85(89)	Function cam follower tip.	0			W
5-85(91) and 5-95(42)	Check pawl guide bracket holding check pawl against advance drum.	0		0	
5-86(75 and 73)	Lateral control and rotary function slides.	0		0	
5-86(76)	Lateral control belt pulley assembly.	0		0	
5-86(91 and 54)	Lateral control and rotary chains	0	0		W
5-95	Rotary and lateral type posi- tioning cam follower stroke adjustment screw ends (1 through 5).	0			0
5-95(1)	Carriage return cam surface.	0	0		
5-95(3)	Automatic carriage return and line feed bail actuator eccentric.	0		0	
5-95(4)	Carriage return lock lever eccentric bushing.	0		0	
5-95(6)	Letters-figures clutch cam surface.	0	0		
5-95(8)	Line feed clutch cam surface.	0	0		
5-95(9)	Bushings at both ends of V lever shaft.	0		0	
5-95(32)	Function sensing finger lever stop strip.	0			0
5-95(33)	Off line function slide levers.	0			0
5-95(34)	Function sensing finger levers where they meet function bar.	0	0		W
5-95(34)	Function sensing finger lever pivots.	0	0		W
5-95(35 and 27)	Function and print spring yoke pivot studs and links.	0	0		W
5-95(38)	Paper feed detent and ratchet.	0	0		W

TABLE 5-9. LUBRICATION INSTRUCTIONS (Cont.)

FIGURE AND INDEX NO. (APPENDIX)	LUBRICATION OR CHECK POINT	SPECIAL INTERVAL	PERIODIC INTERVALS		
		ANY REASSEMBLY	EVERY 250 HOURS	EVERY 1000 HOURS	EVERY 3000 HOURS
5-95(40)	Line feed pawl at pivot point.	0	0		
5-95(40)	Line feed pawl guide bracket.	0			0
5-95(44)	First character adjustment screw (contact point).	0	0		
5-95(45)	Advance ratchet (tip).	0	0		W
5-95(46 thru 52)	Print prevent adjustment screw heads.	0		0	
5-96(21)	Rotary motion spring retainer.	0	0		
5-97(7)	Clutch release finger cam follower surfaces.	0			W
5-97(15)	Type positioning cam followers where they meet the carriage pulley surfaces and type positioning cams.	0	0		
5-97(23)	Start clutch backstop lever eccentric bushing.	0	0		W
5-97(24)	Start clutch release latch pin where it meets the fork in start clutch release arm.	0	0		W
5-97(30 thru 34, 36, 37)	Armature paddle latches where clutch release finger adjustment screws are engaged.	0		0	W
5-97(46)	V lever tab which meets pin in advance drum.	0		0	
5-97(50)	Carriage return shaft bushing between lever and carriage return cam follower on opposite end.	0		0	
5-97(51)	Character advance lever shaft bushings.	0	0		
5-97(52)	Advance prevent stop spring where it engages bail.	0		0	
5-101(1 and 20)	Bushings and pivots on link between rotary detent pawl and print shaft terminal lever.	0	0		W
5-101(3)	Character advance pawl eccentric bushing.	0	0		W
5-101(4 and 5)	Carriage return lever and advance prevent lever tab meeting point.	0			

TABLE 5-9. LUBRICATION INSTRUCTIONS (Cont.)

FIGURE AND INDEX NO. (APPENDIX)	LUBRICATION OR CHECK POINT	SPECIAL INTERVAL	PERIODIC INTERVALS		
		ANY REASSEMBLY	EVERY 250 HOURS	EVERY 1000 HOURS	EVERY 3000 HOURS
5-101(5 and 12)	Advance prevent lever tab where character advance pawl contacts.	0	0		
5-101(13 and 12)	Advance suppression latch where character advance pawl contacts.	0	0	0	
5-101(14)	Check pawl link at check pawl eccentric stud and opposite end.	0	0		
5-101(16)	Advance suppression latch eccentric bushing.	0	0		
5-101(18)	Rotary detent pawl eccentric bushing.	0	0		W
5-101(19)	Check pawl eccentric bushing.	0	0		W
5-101(21)	Rotary detent pawl adjustment screw tip.	0	0		
5-101(23)	Rotary detent pawl pin.			W	
5-101(24)	Index wheel.	0	0		
5-102	Shaft bearings (12 each).	0	0		
5-103	Takeup arm bushing.	0	0		
	All gears in equipment.	G	G		
	All spring loops in equipment.	0	0		0
5-103	Print hammer release bushing.	0	0		
5-103	Print shaft terminal lever where it meets print hammer actuator link and print hammer release.	0	0		W
TIME DELAY MOTOR STOP MECHANISM (AN/TGC-14A(V) only)					
5-69(1)	Advance ratchet.	0	0		W
5-69(2)	Return spial spring. (Do not disassemble ratchets; apply drop of oil between ratchets.)	0		0	
5-69(3)	Reduction ratchet.	0		0	W
5-69(8)	Time delay switch actuator.	0		0	
5-69(12)	Time delay secondary check pawl.	0		0	W
5-69(23)	Timing cam shaft extension.	0	0		W
5-69(26)	Time delay feed and check pawl guide.	0		0	



TABLE 5-9. LUBRICATION INSTRUCTIONS (Cont.)

FIGURE AND INDEX NO. (APPENDIX)	LUBRICATION OR CHECK POINT	SPECIAL INTERVAL	PERIODIC INTERVALS		
		ANY REASSEMBLY	EVERY 250 HOURS	EVERY 1000 HOURS	EVERY 3000 HOURS
5-69(31)	Time delay feed pawl assembly.	0		0	W
5-69(33)	Time delay check pawl assembly.	0		0	W
5-69(35)	Felt Washer	0	0		
5-69(39)	Sleeve	0	0		
	All spring hooks (both ends).	0	0		0
5-69(46)	Roller	0		0	
5-69(47)	Detent spring.	0		0	
KEYBOARD					
5-104	Keyboard cam wick.	0	0		W
5-104	Entire Clutch.	0	0		
5-104	Clutch release cam follower eccentric (felt).	0	0		
5-104	Clutch backstop bushing.	0	0		
5-105	Keyboard code bar prevent lever cam	0	0		
5-105	Pulsing finger bushings (felts)	0	0		
5-105	Key lever leaf springs where they contact key levers.	0	0		
5-105	Clutch release bail bearings.	0	0		
5-105	Repeat key shaft ends.	0		0	
RIBBON FEED MECHANISM					
5-96	Ribbon feed slip clutch gear shaft bearings.	0		0	
5-96	Ribbon spool drive gears.	G	G		
5-96	Reversing cam followers (point of contact)	0			
5-96	Ribbon spool drive gear bearings.	0		0	
5-96	All spring loops.	0			0
5-96(2)	Ribbon feed clutch stop (stop tab contact point).	0			

TABLE 5-9. LUBRICATION INSTRUCTIONS (Cont.)

FIGURE AND INDEX NO. (APPENDIX)	LUBRICATION OR CHECK POINT	SPECIAL INTERVAL	PERIODIC INTERVALS		
		ANY REASSEMBLY	EVERY 250 HOURS	EVERY 1000 HOURS	EVERY 3000 HOURS
5-96(3)	Ribbon rollers.	0		0	
5-96(4, 27)	Left-hand and right-hand tension control brake arms (pivot points).	0		0	
5-96(5)	Ribbon reversing sliding plate assembly (slots).	0		0	
5-96(17)	Clutch shaft worm gear assembly.	G	G	G	
5-96 (24 and 23)	Ribbon feed friction felt washer and bearing felt washers.	0	0		
5-96 (26 and 6)	Left-hand and right-hand ribbon reversing sensing arm pivot points.	0		0	
5-96(29)	Ribbon feed backstop (where it rides clutch).	0	0		
<b>ELECTRICAL CHASSIS</b>					
5-90(6)	Paper brake link pivots.	0	0		0
5-90(11)	Dancer roll tube bearings (paper brake release arm).	0	0		0

TABLE 5-10. TENSION VALUES

FIGURE AND INDEX (APPENDIX)	ITEM	LOAD LENGTH (INCHES)	LOAD (OUNCES)
5-69 (30)	Time Delay Feed Pawl Helical Spring	1.000 ±0.0312	2.5
5-69 (2)	Return Spiral Spring		1.5 ±0.15 in.-oz at 1/2 turn; 2.6 ±0.26 in.-oz at 1-1/2 turns.
5-69 (47)	Detent Spring		5 oz (To move from detent.)
5-69 (14)	Time Delay Secondary Check Pawl Spring	0.6250 ±0.0312	1.5
5-70 (4)	Backstop Lever Spring	0.8750	32-36
5-75 (9); 5-76 (10)	Selector Shaft Bias Spring	1.1406 ±0.0156	5.6432
5-77 (43)	Lock Lever Actuator Arm Helical Spring	1.0625	3
5-77 (44)	Automatic Carriage Return and Line Feed Bail Actuator Helical Spring	1.3125	7.5
5-78 (9)	Clutch Backstop Spring	1.125	28
5-78 (35)	Inter-arm Spring	1.312	32-34
5-78 (26)	Line Feed Pawl Spring	1.375	3
5-78 (18)	Safety Spring	0.6875	60±5
5-78 (51)	Print and Function Clutch Release Arm Spring	1.0625- 1.125	16-18
5-78 (60)	Timing Cam Shaft Spring (Compression)	0.250	16-25
5-79 (26)	Detent Helical Spring (Compression)	0.375	6
5-79 (10)	Function Helical Spring	2.375 2.750	32±3.2 42±4.2
5-79 (18)	Print Helical Spring	2.375 2.750	16±1.6 20±2.0
5-80 (Insert)	Actuator Spring (AN/TGC-14 (V) only)	90 degrees	0.28216-0.52905
5-80 (Insert)	Code Bar Spring (AN/TGC-14(V) only)	0.9375 1.1094	9±1 12±1
5-80 (Insert)	Compression Spring (AN/TGC-14(V) only)	0.2812	4±0.5
5-82 (13)	Rotary Motion Spring		2.7 in.-oz at 4 turns.
5-82 (54)	Print Hammer Return Spring	1.1875	9-11
5-82 (50 and 43)	Vibrator Arm (Ribbon)		2.5 (to open)
	Pad Spring	84 degrees	6-8
5-83 (29)	Paper Pressure Release Lever Spring	1.000	2 (min.)
5-83 (18)	Pressure Roll Spring	0.480	32-36
5-83 (5)	Paper Feed Detent Spring	0.8437 0.9062	24 32
5-84 (9)	Carriage Return Spiral Spring		16 in.-oz at 1 turn; 19-22 in.-oz at 4 turns
5-84 (23)	Lateral Tension Helical Spring	0.640 (max. deflection)	30±1
5-84 (29)	Range Finder Lock Helical Spring (Compression)	0.500	15
5-85 (27)	Advance Prevent Lever Spring	1.125	5

TABLE 5-10. TENSION VALUES (Cont)

FIGURE AND INDEX (APPENDIX)	ITEM	LOAD LENGTH (INCHES)	LOAD (OUNCES)
5-85 (25)	Bounce Prevent Lever Spring	1.6250	30
		1.750	40
5-85 (36)	Character Advance Pawl Spring	0.5937	9
		0.5312	7
5-85 (60); Figure 5-34	Lifter Arm Spring	0.049	18
5-85 (88); Figure 5-23	Function Lever Compression Spring	0.375	32
5-85 (52)	Rotary Detent Pawl Spring	1.125	29
		1.1875	36
5-85 (62); Figure 5-30	Check Pawl Spring	0.875	4
5-86 (Insert)	Return Stop Spring	180 degrees	2-3
5-86 (25)	Function Backstop Spring	1.000	23
		1.0625	25
5-86 (22)	Function Clutch Release Arm Return Helical Spring	1.250	5
		1.5625	8
5-86 (12)	Function Sensing Finger Lever Helical Spring	0.625±0.0312	8
5-86 (23)	Off Line Letters Sensing Finger Lever Spring	0.500±0.0312	4
5-86 (38)	Print Prevent Rod Actuator Arm Bias Spring	1.9375	1.5
5-86 (82)	Slack Takeup Spring (Compression)	1.000	3
		0.437	8-10
5-86 (96 and 49)	Lateral Control Belt Strip and Rotary Cable Strip Safety Spring	1.125	4
5-86 (104)	Off Line Function Return Helical Spring	0.875	6
		1.093	9
5-87 (Insert)	Compression Spring (AN/TGC-14(V) only)	0.234±0.010	2±0.5
5-87 (47)	Spring	0.4687	2±0.5
5-87 (37)	Spring	1.125	8±0.5
5-87 (24)	Secondary No. 3 Cam Follower Spring	1.750	28±3
		1.9375	40±4
5-88 (19)	Ribbon Feed Backstop Helical Spring	1.2187±0.0312	28-32
5-88 (6)	Clutch Stop Helical Spring	1.0937	8
		1.1562	10
5-88 (22)	Reversing Cam Follower Spring	1.500	20±1
5-88 (26)	Tension Control Brake Arm Spring	1.250	10±1
5-89 (58) (Sheet 1)	Keyboard Lock Bar Helical Spring	1.312	10±1
5-89 (14) (Sheet 1)	Helical Spring	1.0312	15±2
5-89 (16) (Sheet 1)	Helical Spring	1.000	24±2
5-89 (11) (Sheet 2)	Clutch Release Helical Spring	1.0625	3
5-89 (8) (Sheet 3)	Backstop Spring	0.750	22±2
5-89 (21) (Sheet 2)	Repeat Key Lever Helical Spring	1.000	35±2
5-89 (40)	Spring	0.4062	6
		0.6562	12
5-90 (13)	Paper Brake Link Spring	1.000	2.5
		1.1875	3

TABLE 5-10. TENSION VALUES (Cont)

FIGURE AND INDEX (APPENDIX)	ITEM	LOAD LENGTH (INCHES)	LOAD (OUNCES)
5-90 (38**)	Contact Block (Breaker)		1.5 (to open)
4-7	Clutch Bias Compression Spring	0.156	3
4-32	Off Line Function Button Spring	0.6562 0.8594	5±2 14±2
3-1 (4*)	Helical Compression Spring	0.2187	6-8

\*Part of copy window release mechanism.

\*\*Part of contact block.

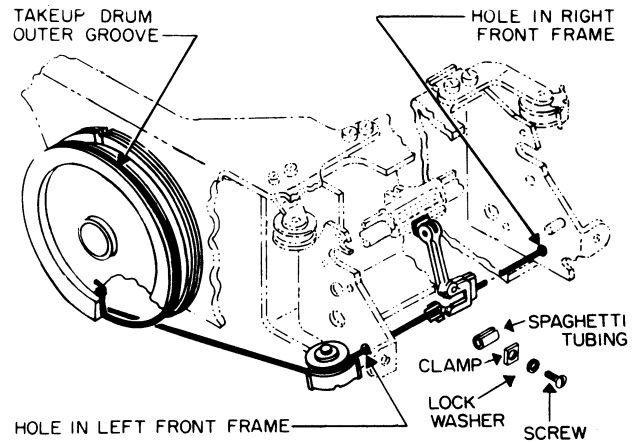

Figure 5-1. Hammer Clamp Location

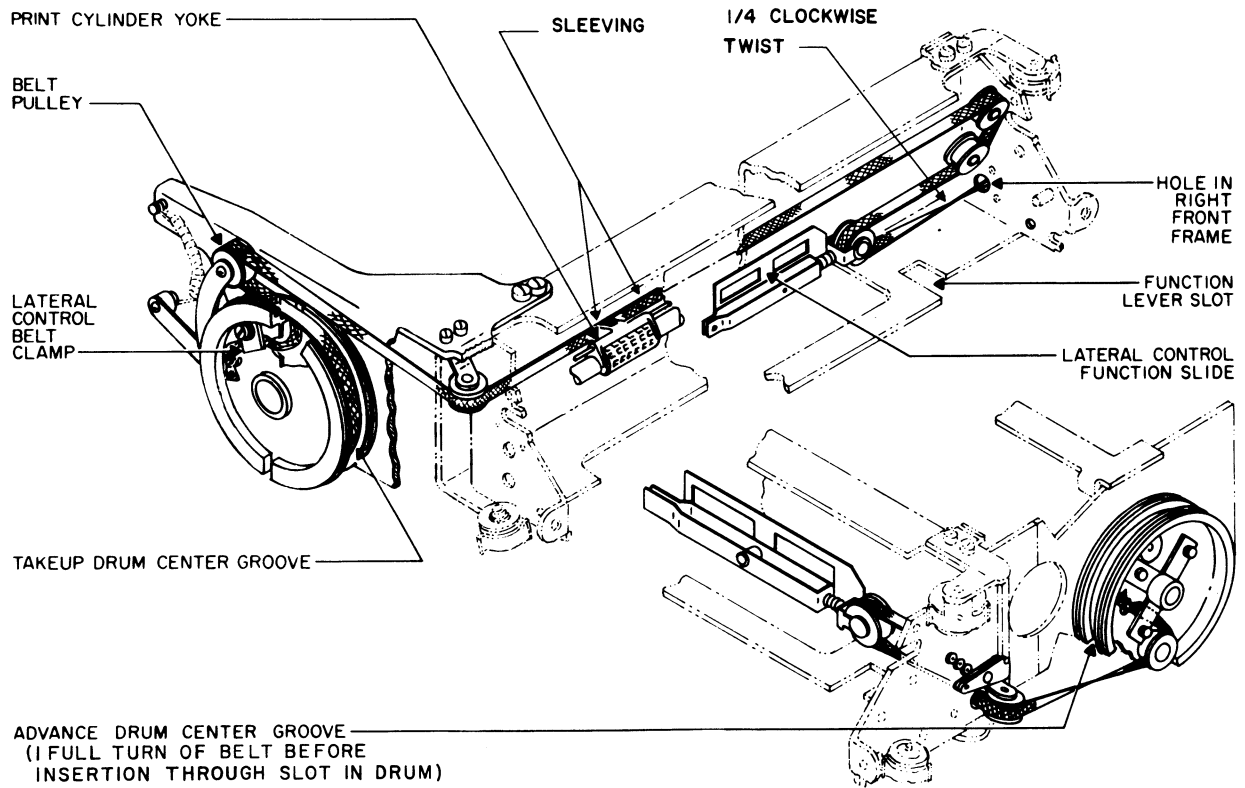

Figure 5-1A. Fiberglass Lateral Control Belt Installation, Belt Threading Diagram

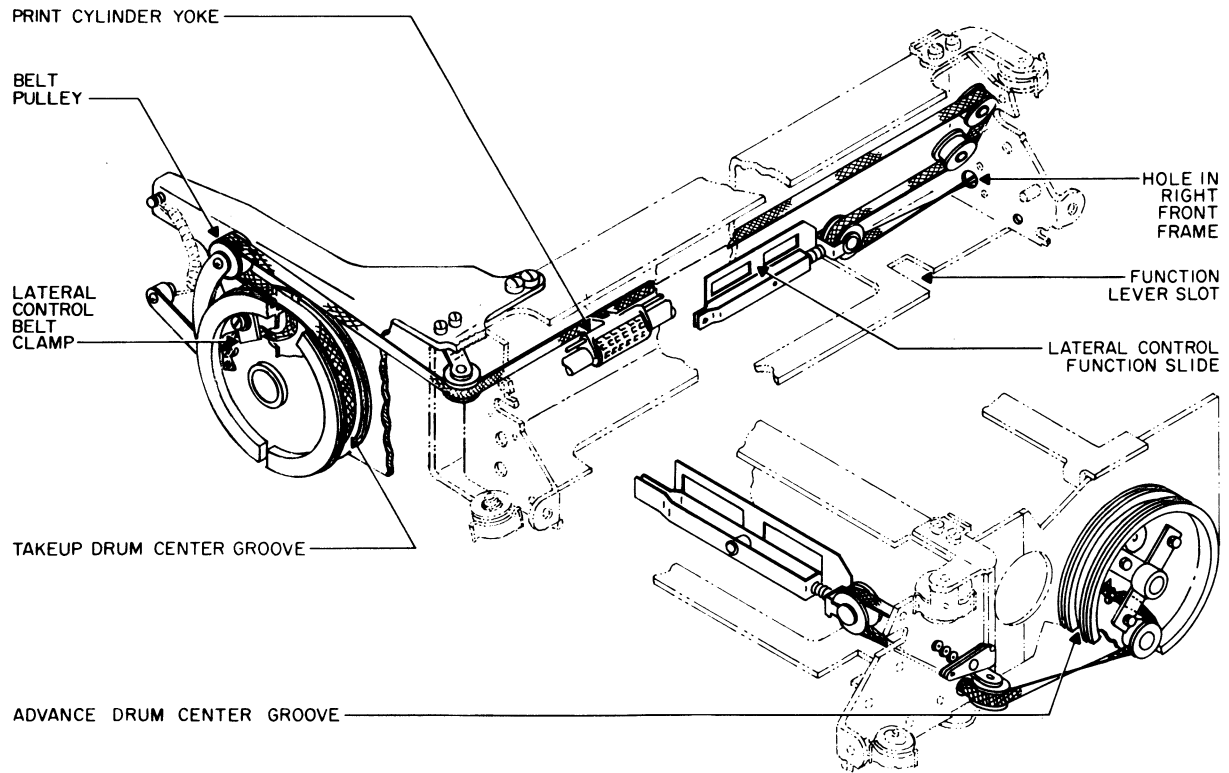

Figure 5-2. Nylon Lateral Control Belt Installation, Belt Threading Diagram

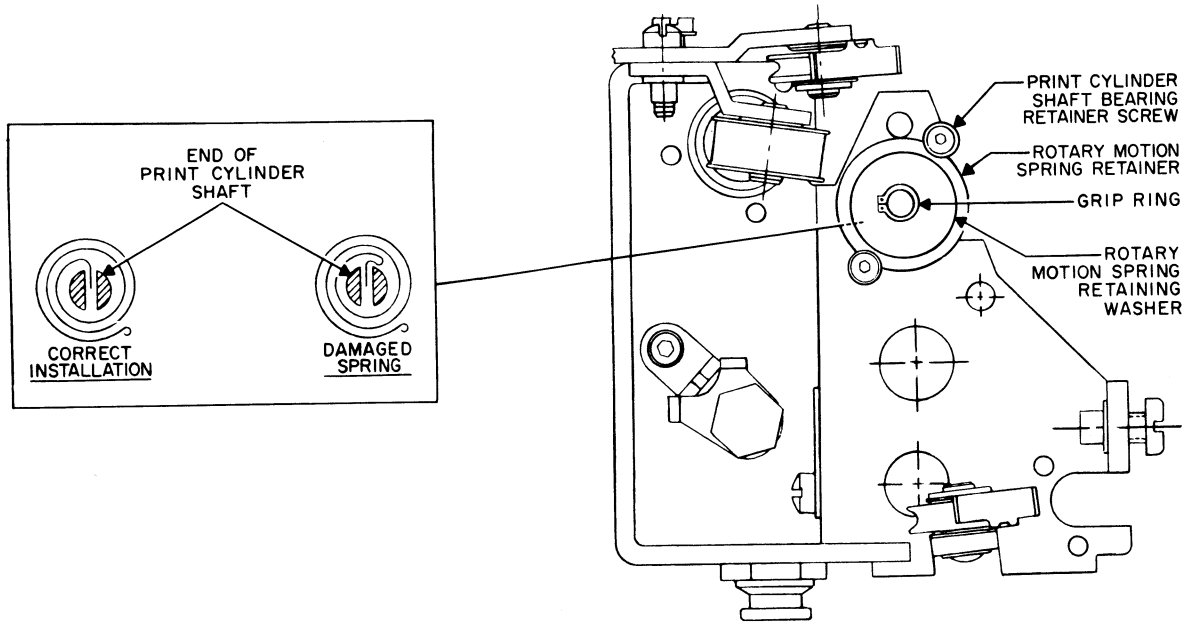

Figure 5-3. Rotary Cable Installation, Left-Side View

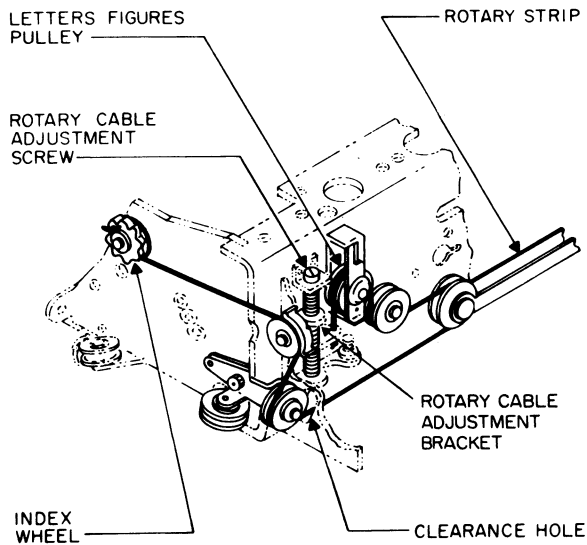

Figure 5-4. Rotary Cable Installation, Cable Threading Diagram

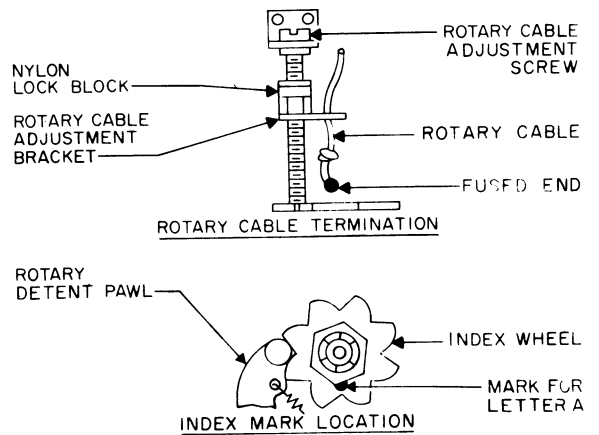

Figure 5-5. Rotary Cable Installation, Detail Views



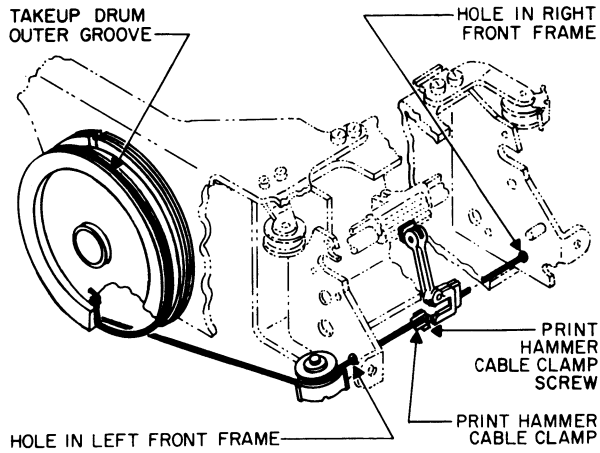

Figure 5-6. Print Hammer Cable Installation,  
Cable Threading Diagram

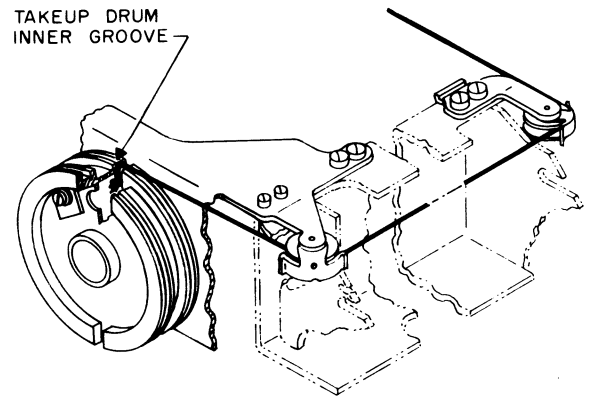

Figure 5-8. Return Cable Installation,  
Cable Threading Diagram

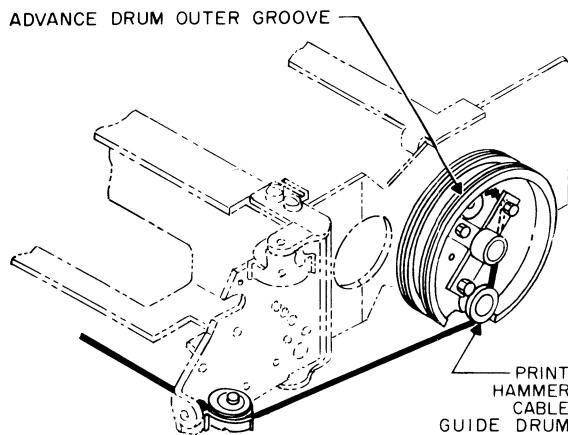

Figure 5-7. Print Hammer Cable Installation,  
Securing Cable to Advance Drum

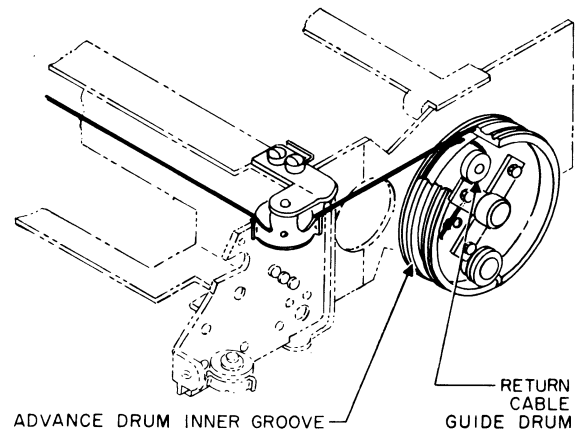
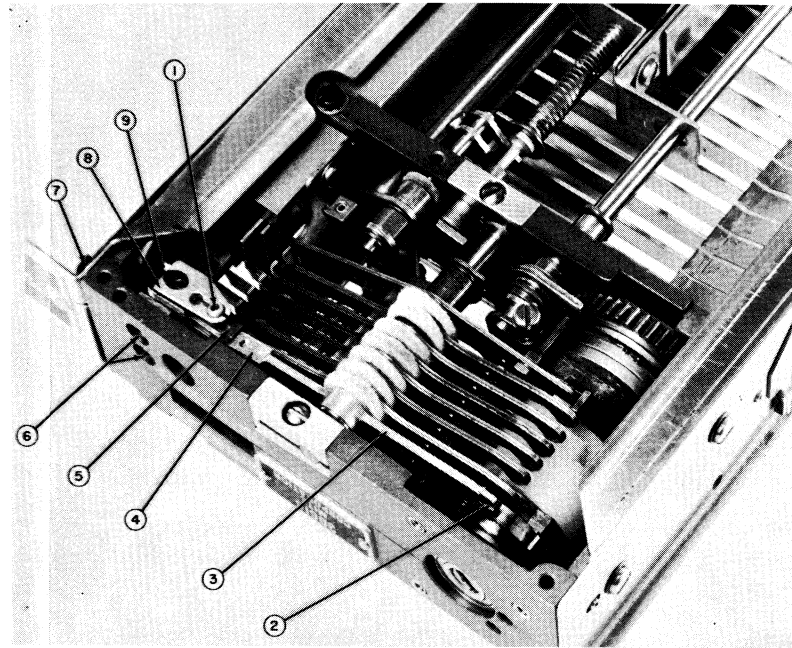
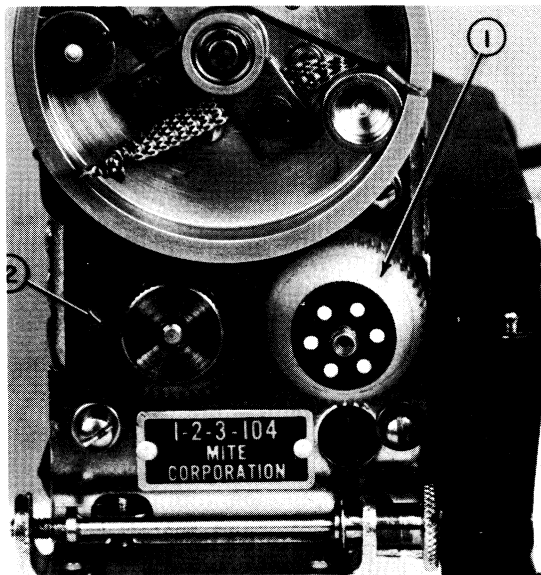

Figure 5-9. Return Cable Installation,  
Securing Cable to Advance Drum



- 1 Adjustment Setscrew
- 2 Cam Follower Tip
- 3 Master Pulsing Cam Follower
- 4 Master Pulsing Cam Follower Screw
- 5 Contact Actuator
- 6 Attaching Screws
- 7 Keyboard Cover
- 8 Master Pulsing Contact Assembly
- 9 Contact Lead Wires

Figure 5-10. Master Pulsing Contact Assembly Replacement



- 1 Speed Change Gear
- 2 Idler Gear

Figure 5-11. Turning the Mainshaft by Hand

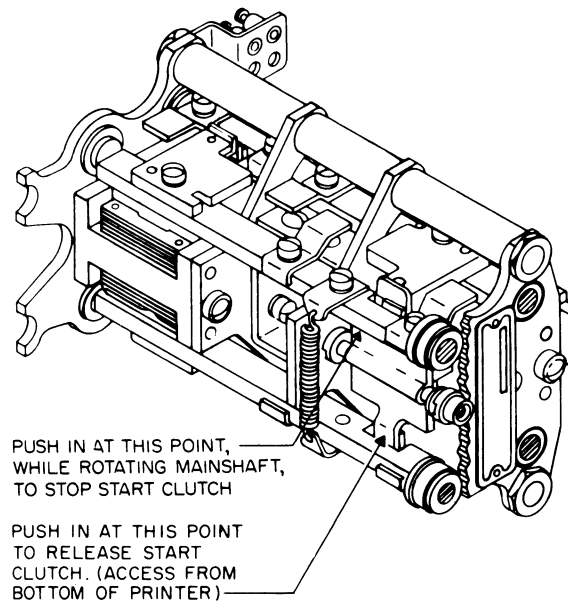

Figure 5-12. Release of Start Clutch

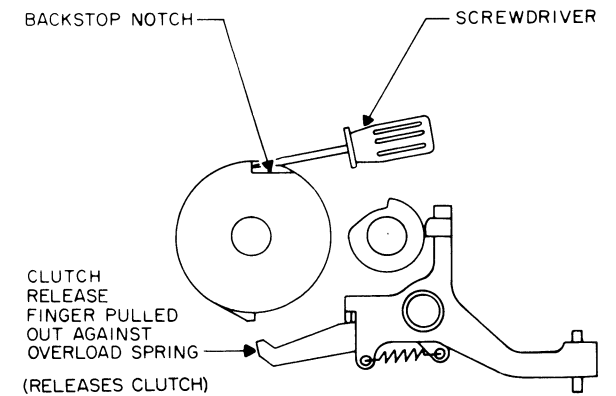

Figure 5-13. Pushing Clutches into Position

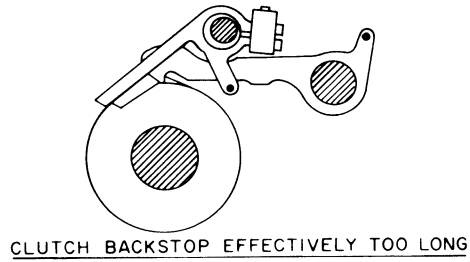
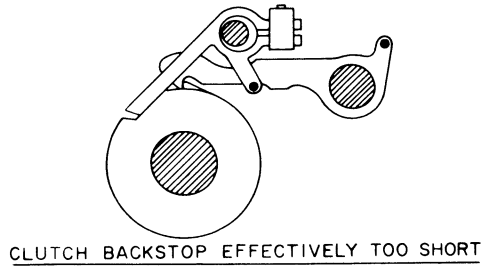
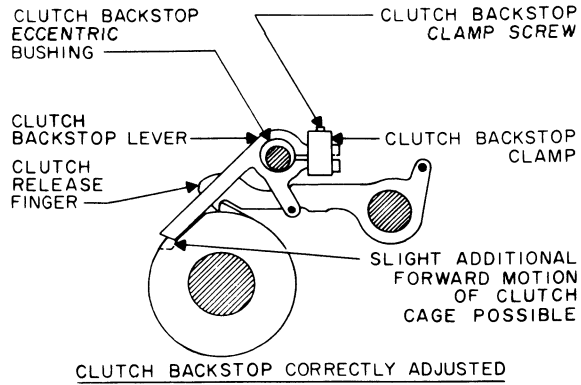
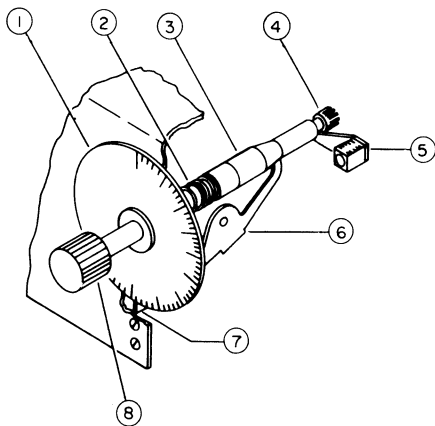

Figure 5-14. Clutch Back-Stop Adjustment



- 1 Range Dial
- 2 Range Finder Lock Helical Spring
- 3 Conical Range Finder Slide Lock
- 4 Range Pinion
- 5 Retaining Lever
- 6 Range Finder Lock Lever
- 7 Range Dial Pointer
- 8 Range Finder Lock Knob

Figure 5-15. Range Dial Mechanism

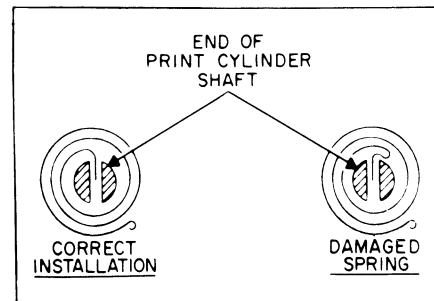

Figure 5-16. Rotary Spring Adjustment

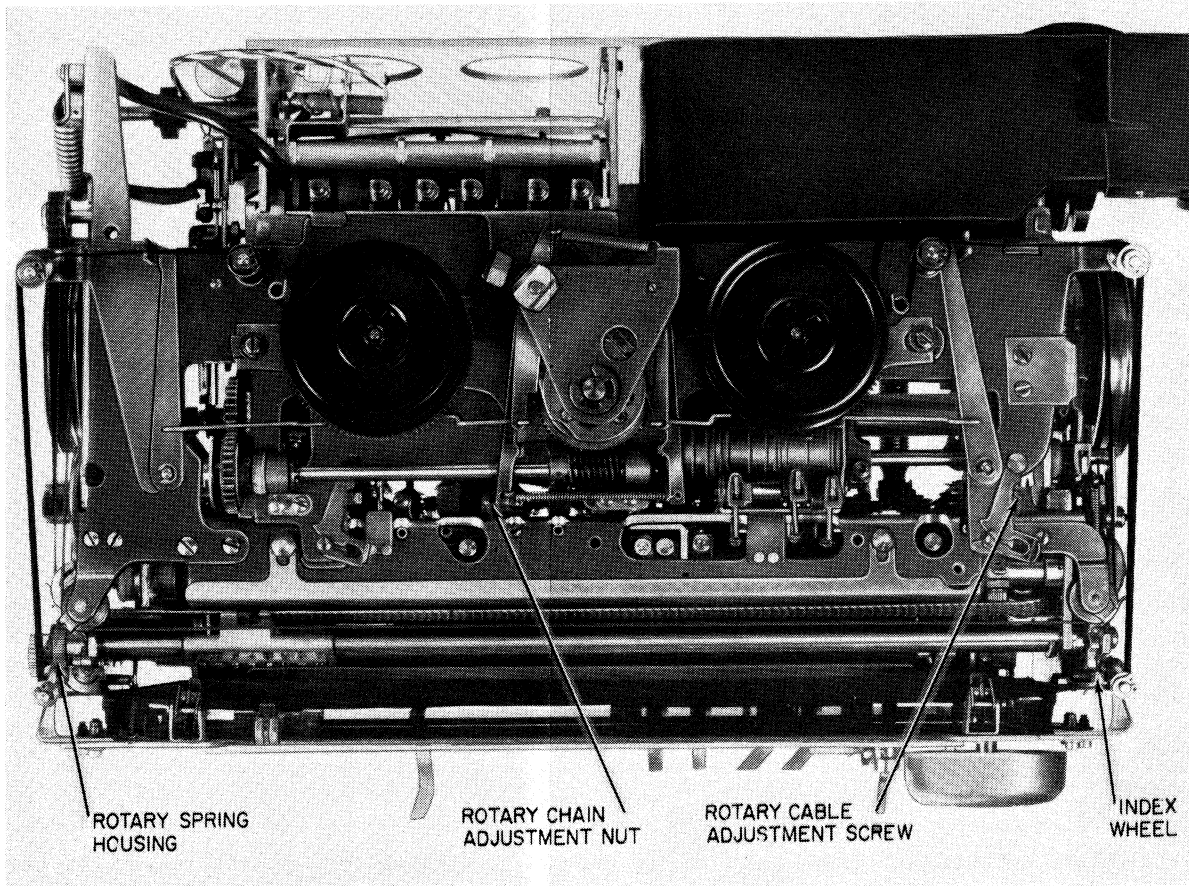

Figure 5-18. Rotary Cable Adjustment

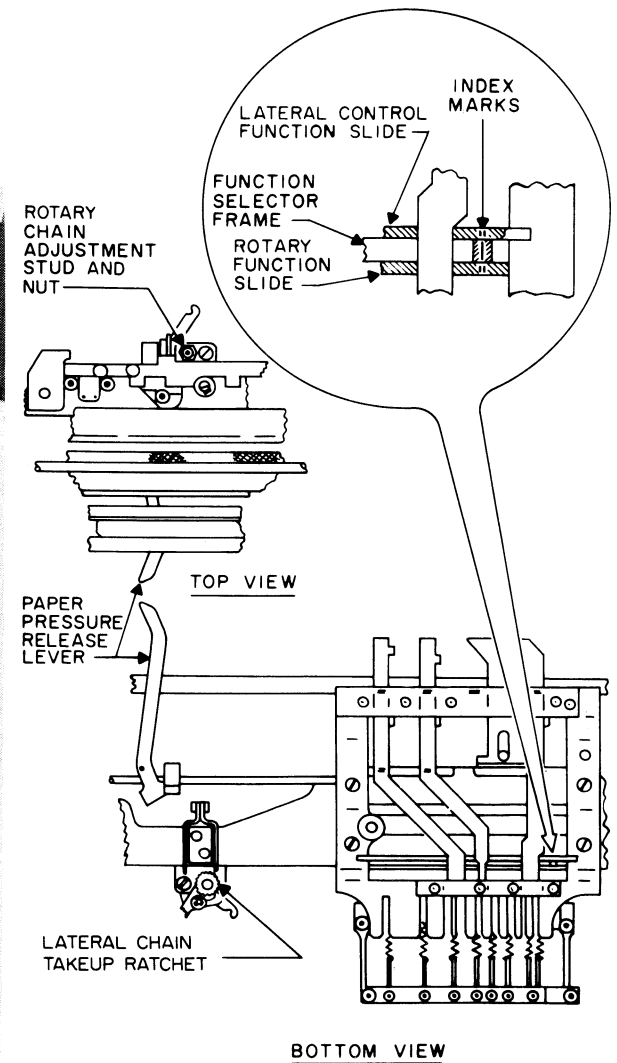

Figure 5-17. Rotary Function Slide Adjustment

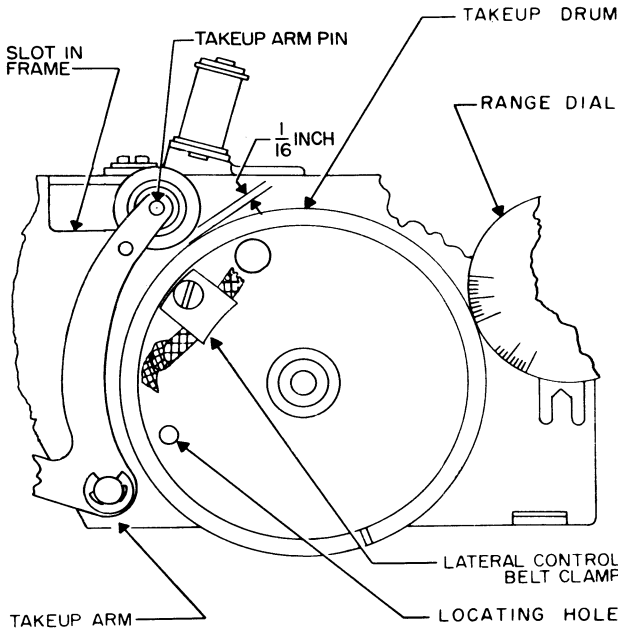

Figure 5-19. Lateral Belt Adjustment, Clearance Requirements

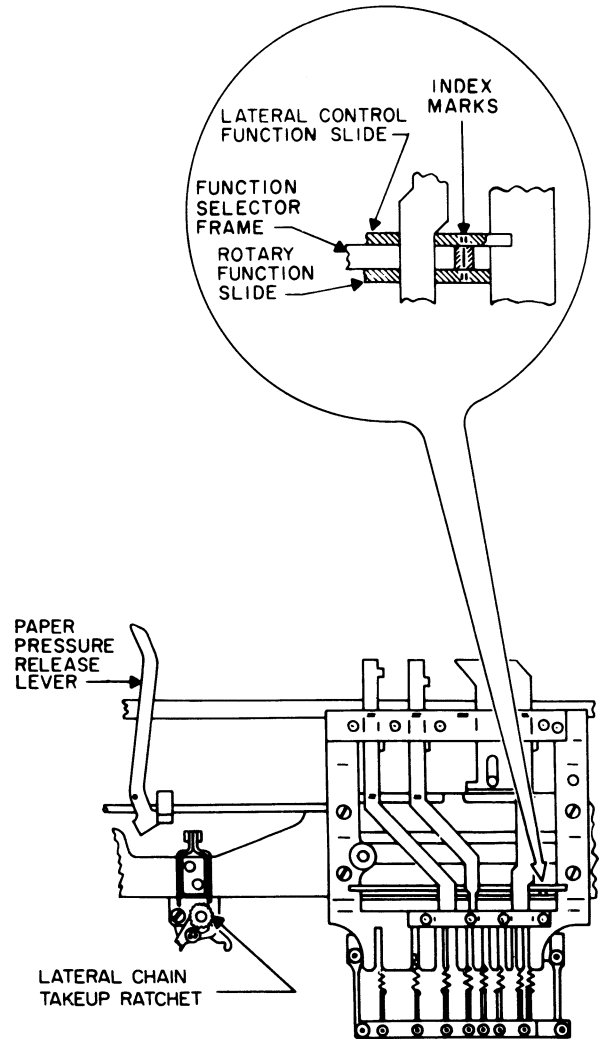

Figure 5-20. Lateral Function Slide Alignment

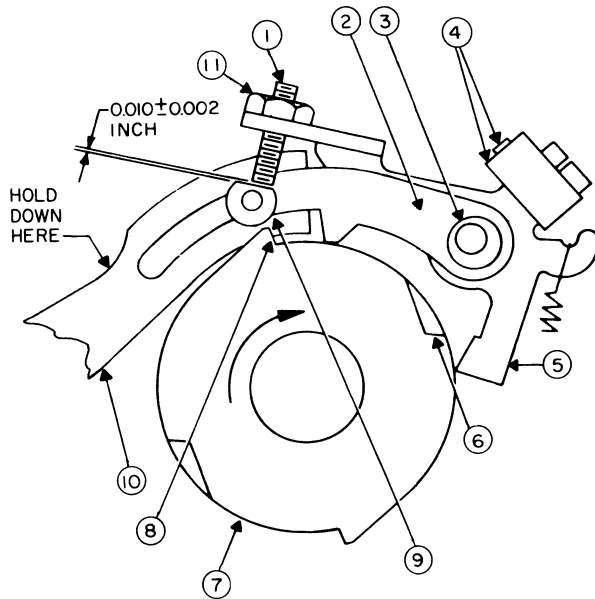
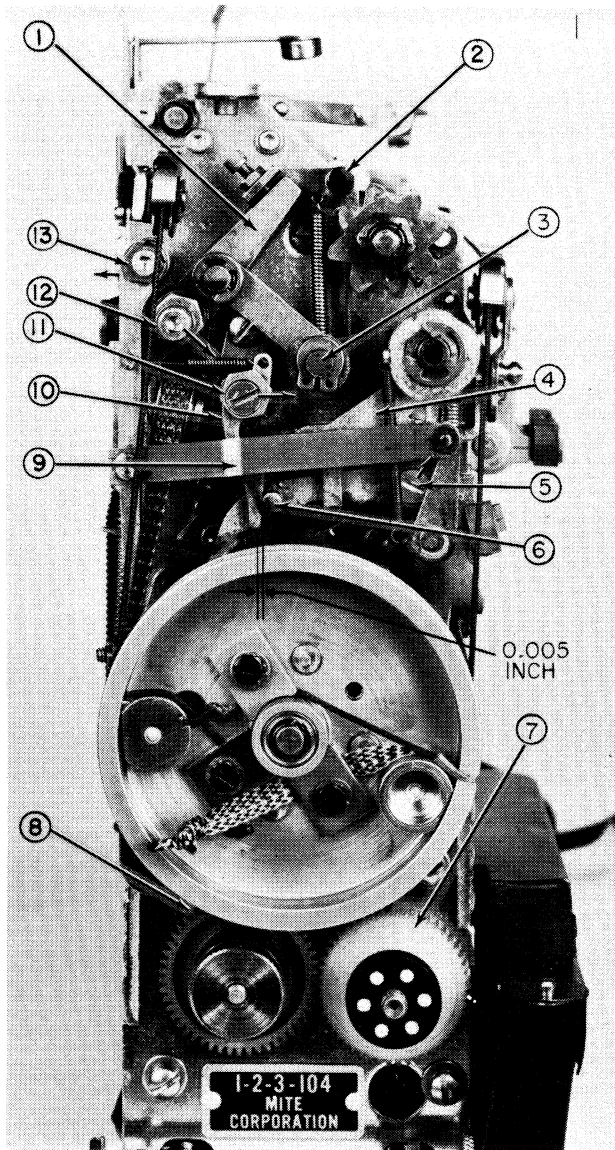

Figure 5-21. Start Clutch Adjustment

- 1 Start Clutch Adjustment Screw
- 2 Release Latch
- 3 Eccentric Bushing
- 4 Backstop Clamp - Backstop Clamp Screw
- 5 Backstop
- 6 Restoring Cam Notch
- 7 Cage
- 8 Stop Tab
- 9 Release Latch Pin
- 10 Release Arm
- 11 Locking Nut



- 1 Rotary Detent Lifter Arm
- 2 Rotary Detent Pawl Pin
- 3 Function Shaft Terminal Lever
- 4 Advance Prevention Lever
- 5 Feed Pawl Eccentric
- 6 Advance Feed Pawl Pin
- 7 Speed Change Gear
- 8 Idler Gear
- 9 Contact Point (Advance Prevention Lever and Catch)
- 10 Advance Prevention Catch
- 11 Advance Prevention Eccentric
- 12 Detent Arm Eccentric
- 13 Advance Check Pawl Eccentric

Figure 5-22. Right Side - Printer

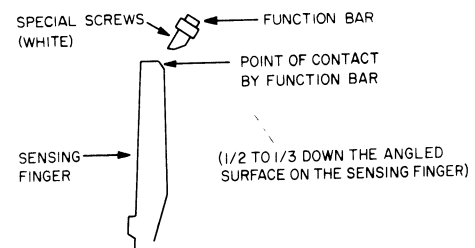

Figure 5-23. Function Bar Adjustment

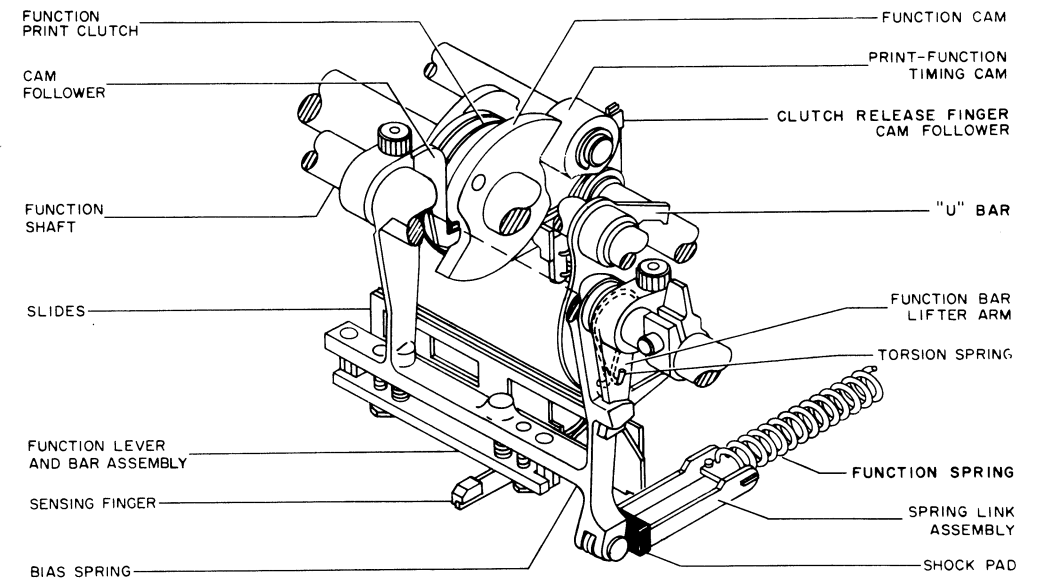

Figure 5-24. Function Shaft Adjustment

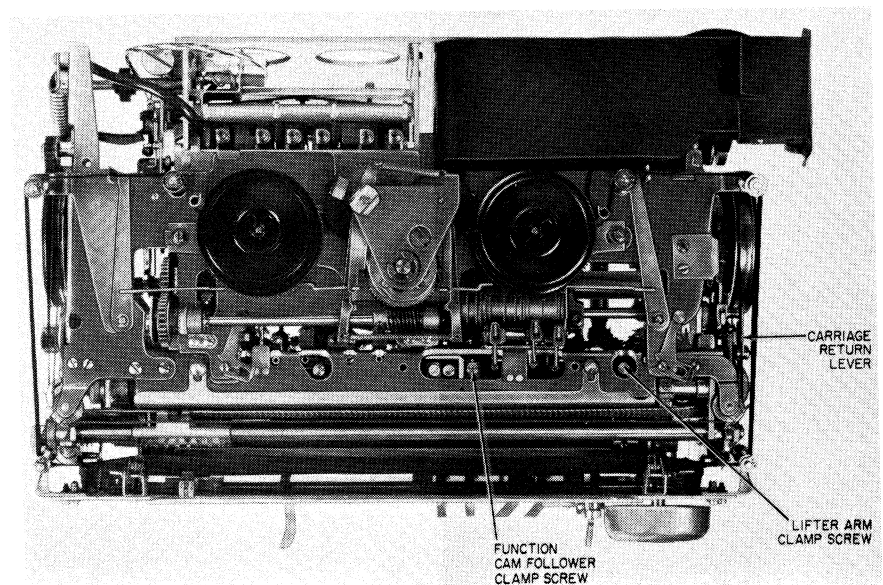
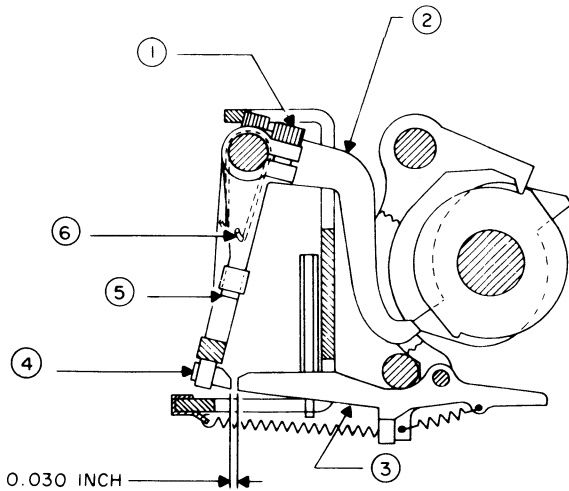
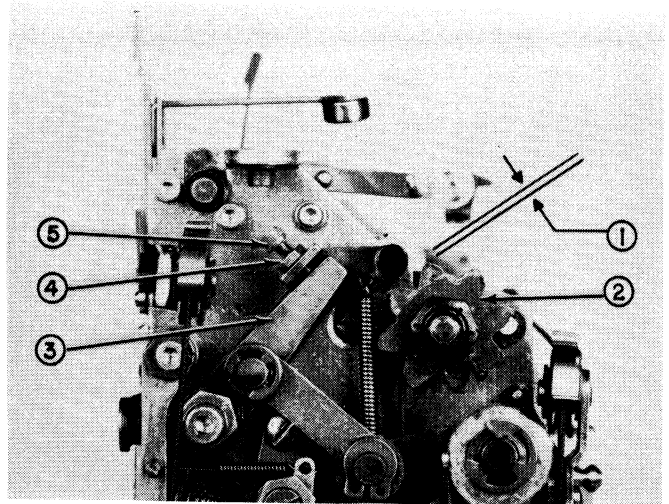

Figure 5-25. Function Selector, Start of Function Cycle



- 1 Lifter Arm Clamp Screw
- 2 Function Cam Follower at High Point of Cam
- 3 Sensing Finger
- 4 Function Bar
- 5 Lifter Arm
- 6 Torsion Spring

Figure 5-26. Function Shaft Adjustment



- 1 0.010
- 2 Index Wheel
- 3 Actuator
- 4 Locknut
- 5 Adjustment Screw

Figure 5-27. Rotary Detent Mechanism

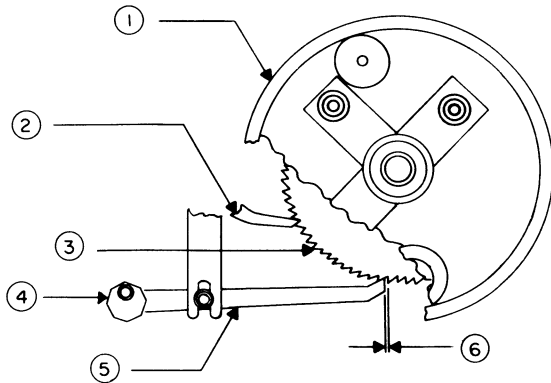

View A

- 1 Advance Drum
- 2 Advance Feed Pawl
- 3 Advance Ratchet
- 4 Advance Check Pawl Eccentric
- 5 Advance Check Pawl
- 6 1/4 tooth clearance

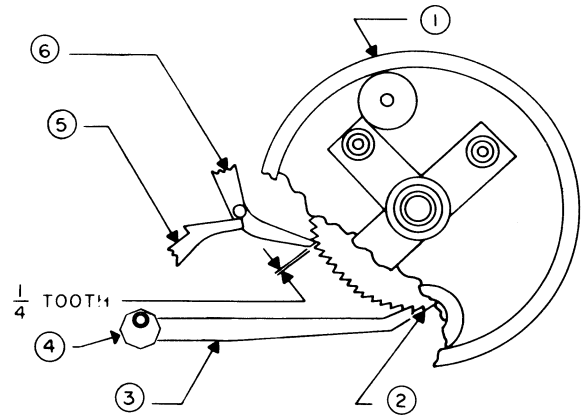

View B

- 1 Advance Drum
- 2 Advance Ratchet
- 3 Advance Check Pawl
- 4 Advance Check Pawl Eccentric
- 5 Advance Prevention Catch
- 6 Advance Feed Pawl

Figure 5-28. Character Advance Mechanism

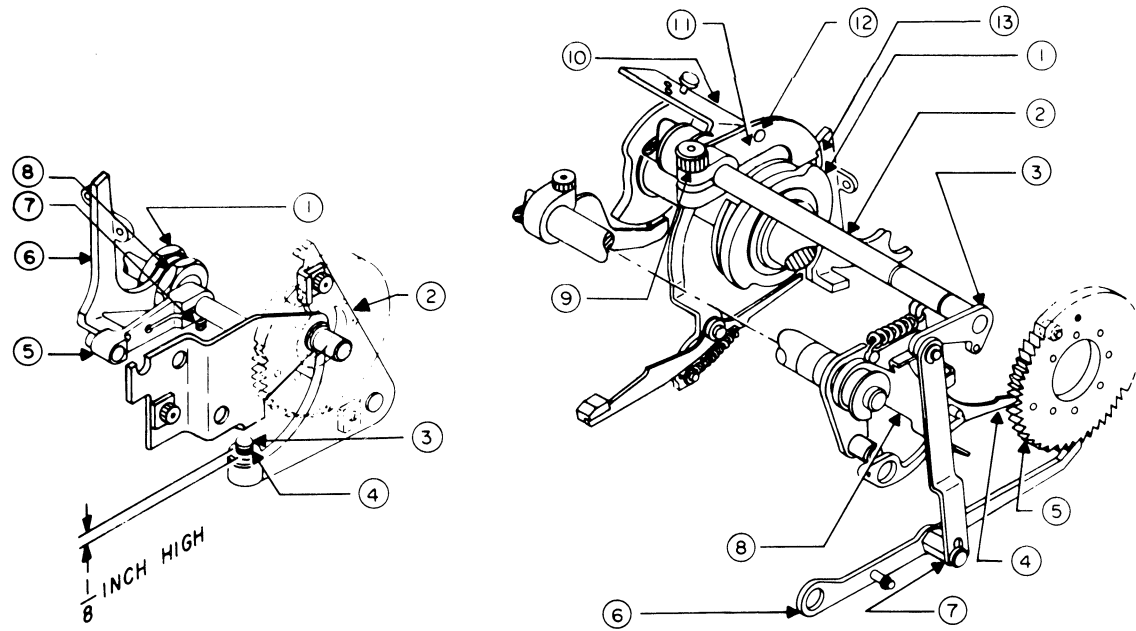

View A

- 1 Carriage Return Lock Lever Eccentric
- 2 V Lever
- 3 Point 3
- 4 First Character Adjustment Screw
- 5 Lock Lever Disconnect Arm
- 6 Carriage Return Lock Lever
- 7 Lock Lever Disconnect Arm Screw
- 8 Lock Lever Locknut

View B

- 1 Carriage Return Cam
- 2 Carriage Return Shaft
- 3 Carriage Return Lever
- 4 Advance Feed Pawl
- 5 Advance Ratchet
- 6 Advance Check Pawl
- 7 Check Pawl Link
- 8 Advance Prevention Lever
- 9 Cam Follower Clamp Screw
- 10 Advance Prevent Bail
- 11 Carriage Return Cam Follower
- 12 Pin on Carriage Return Cam Follower
- 13 Carriage Return Lock Lever

Figure 5-29. Carriage Return Linkage

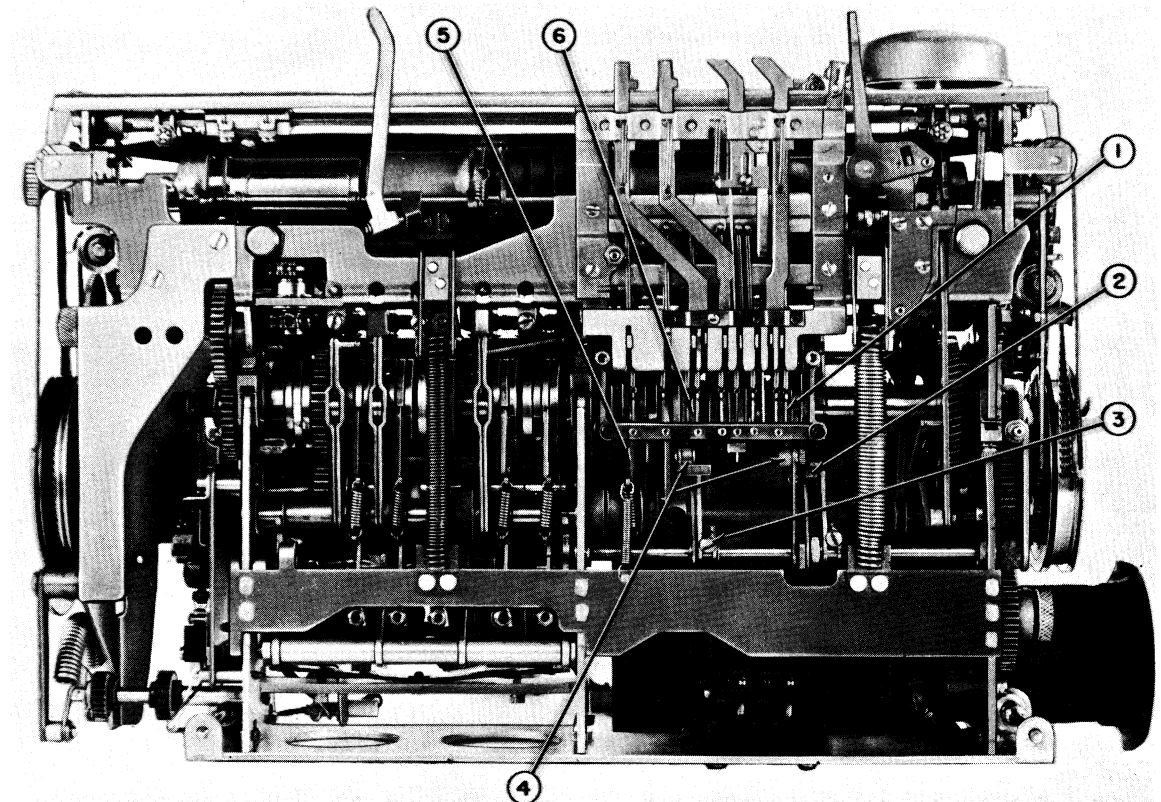

- 1 Automatic Carriage Return Sensing Finger
- 2 Automatic Carriage Return Eccentric
- 3 Actuator Arm Screw
- 4 Carriage Return/Line Feed Actuators
- 5 Function Clutch Release Finger
- 6 Line Feed Sensing Finger

Figure 5-33. Automatic Carriage Return and Line Feed Adjustment

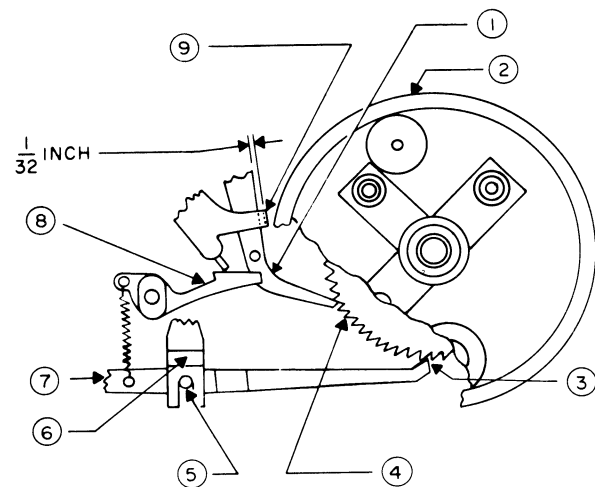

- 1 Advance Feed Pawl
- 2 Advance Drum
- 3 Point
- 4 Advance Ratchet
- 5 Check Pawl Link Eccentric
- 6 Check Pawl Link
- 7 Advance Check Pawl
- 8 Latch
- 9 Advance Prevention Lever

Figure 5-30. Carriage Return Lever Adjustment

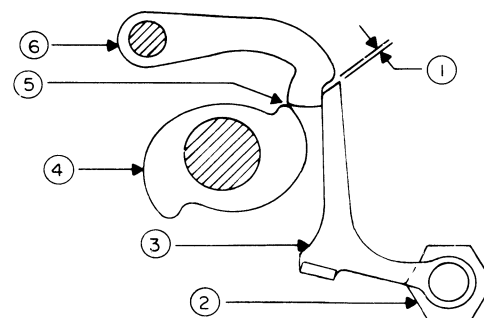

- 1 0.010 inch Clearance
- 2 Carriage Return Lock Lever Eccentric
- 3 Carriage Return Lock Lever
- 4 Carriage Return Cam
- 5 Cam Follower on High of Cam
- 6 Carriage Return Cam Follower

Figure 5-31. Carriage Return Lock Lever Adjustment

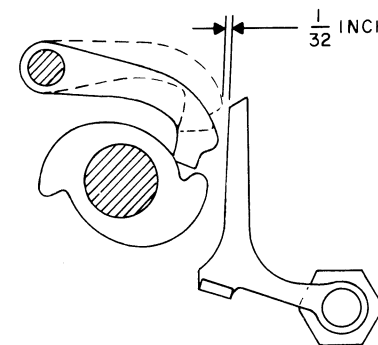
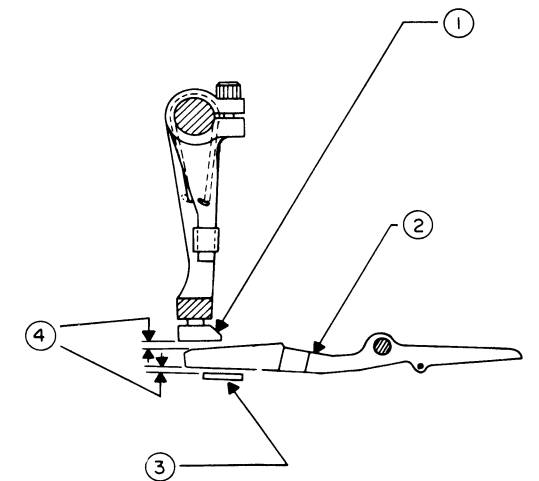

Figure 5-32. Carriage Return Lock Lever Adjustment



- 1 Function Bar
- 2 Sensing Finger
- 3 Stop Strip
- 4 1/32 inch Clearances

Figure 5-34. Function Bar and Sensing Finger Clearance Adjustment



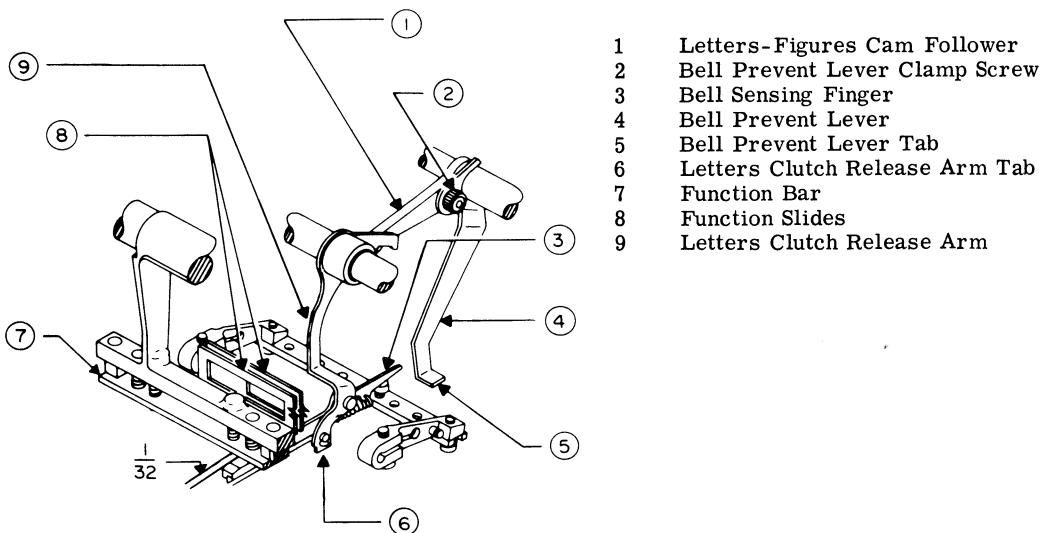

Figure 5-35. Bell Sensing Finger Adjustment

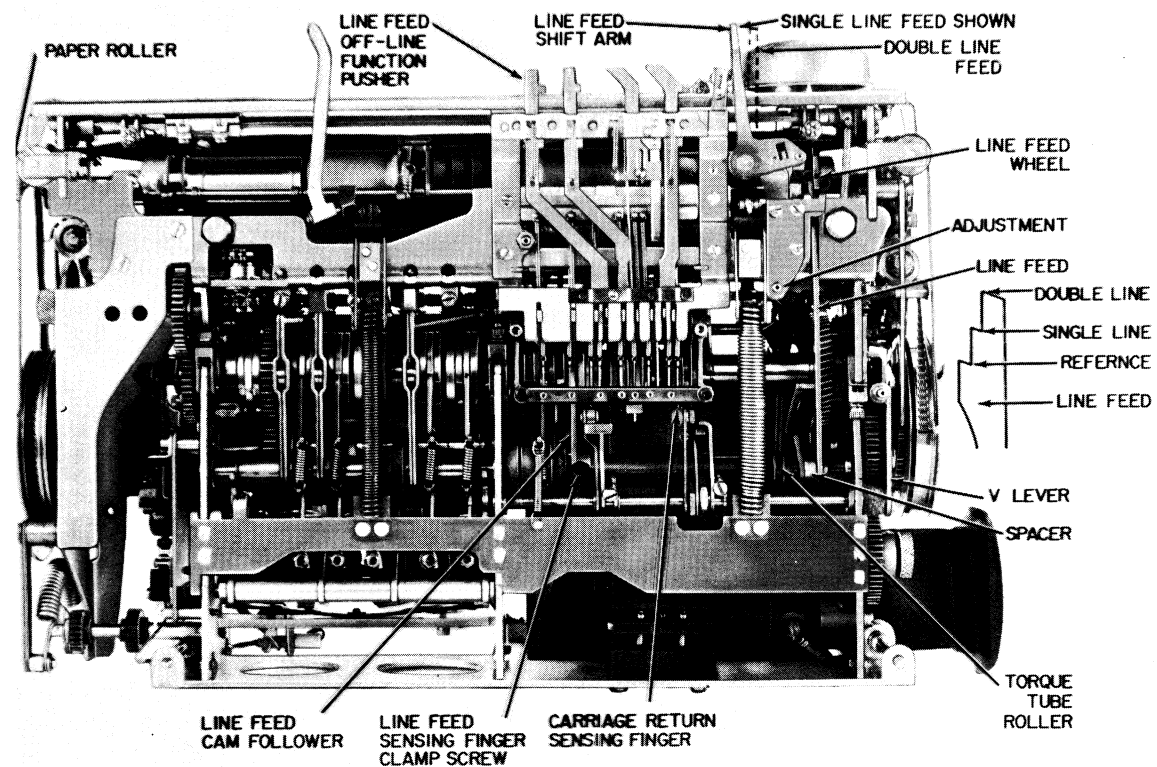
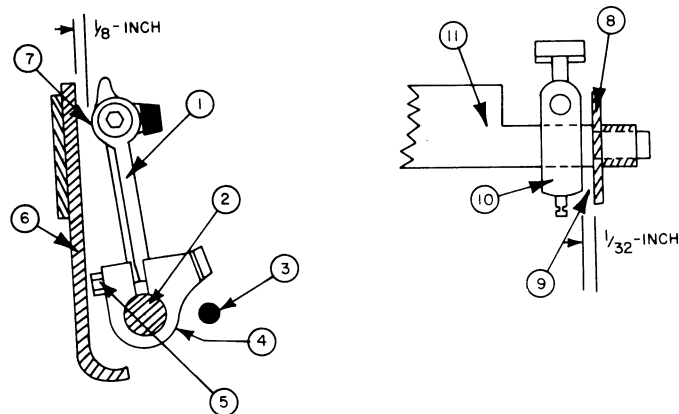

Figure 5-36. Line Feed Adjustment



- |   |                       |    |                     |
|---|-----------------------|----|---------------------|
| 1 | Hammer Assembly       | 7  | 1/8 inch Clearance  |
| 2 | Hammer Shaft          | 8  | Bearing             |
| 3 | Pin Stud              | 9  | 1/32 inch Clearance |
| 4 | Hammer Backstop Clamp | 10 | Hammer Backstop     |
| 5 | Backstop Screw        | 11 | Hammer Shaft        |
| 6 | Front Plate           |    |                     |

Figure 5-37. Hammer Backstop Adjustment

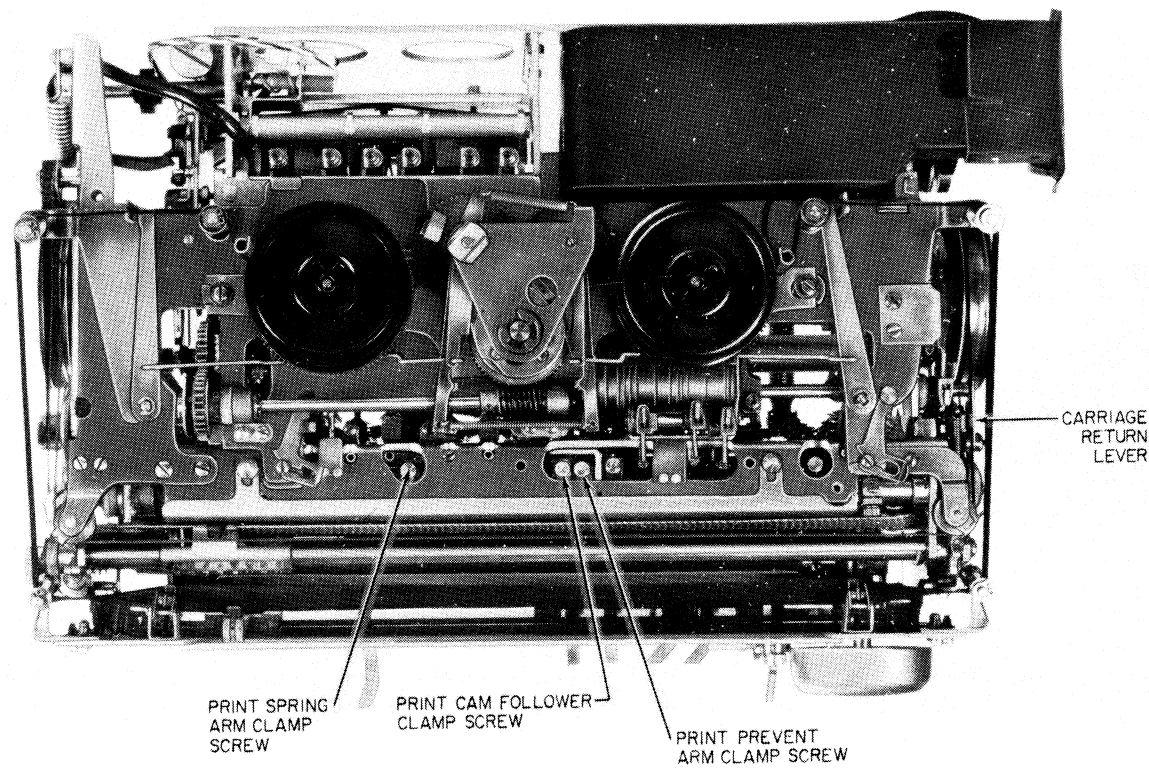
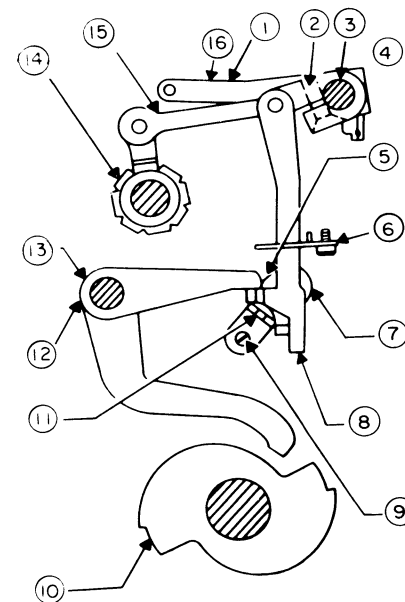
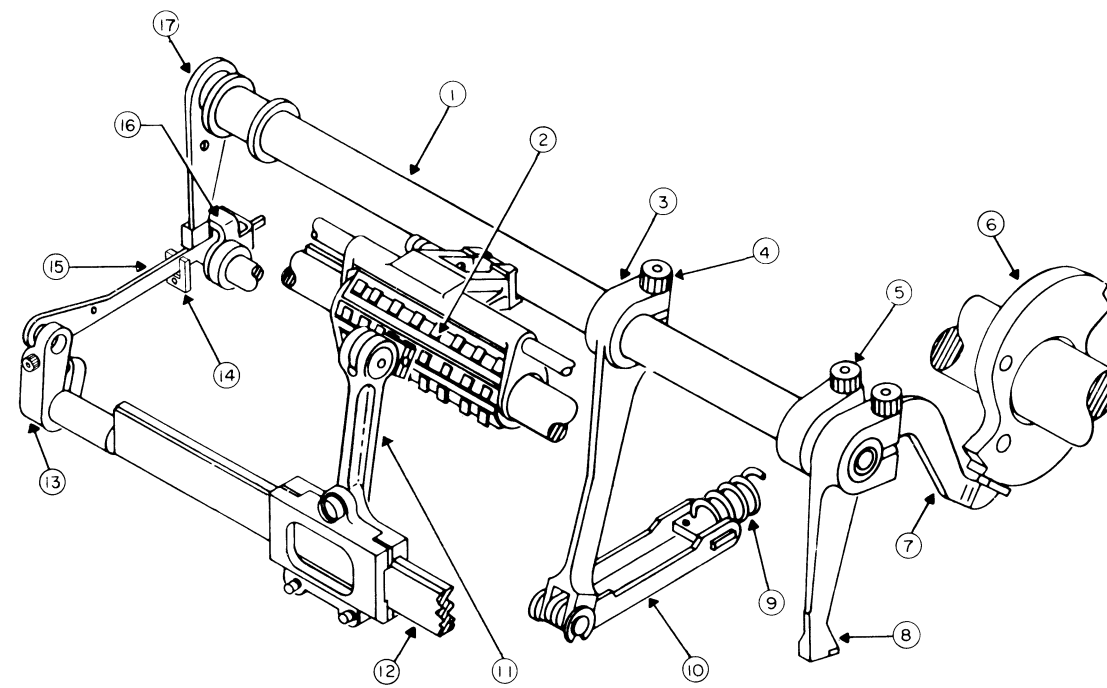

Figure 5-38. Print Disconnect and Print Shaft Adjustments



- 1 Ribbon Vibrator
- 2 Hammer Link Clamp Screw
- 3 Ribbon Vibrator Arm Clamp Screw
- 4 Minimum Perceptible Clearance
- 5 Hammer Shaft Arm Guide Bracket
- 6 Hammer Disconnect Link
- 7 Hammer Shaft Arm
- 8 Hammer Shaft Arm
- 9 Stop Screw
- 10 Cam
- 11 Stop
- 12 Print Shaft Terminal Lever
- 13 Rotate Terminal Lever by Raising and Lowering Print Spring Arm
- 14 Type Cylinder
- 15 Hammer
- 16 Press down here to hold hammer against cylinder

Figure 5-39. Print Disconnect Adjustment



- 1 Print Shaft
- 2 Type Cylinder
- 3 Print Spring Arm
- 4 Print Spring Arm Clamp Screw
- 5 Print Cam Follower Clamp Screw
- 6 Print Cam
- 7 Print Cam Follower
- 8 Print Prevent Arm
- 9 Print Prevent Arm Clamp Screw
- 10 Print Spring Yoke
- 11 Hammer
- 12 Hammer Shaft
- 13 Hammer Link Clamp
- 14 Hammer Shaft Link Guide Plate
- 15 Hammer Shaft Link Arm
- 16 Hammer Disconnect Link
- 17 Terminal Lever

Figure 5-40. Printing Action Linkage

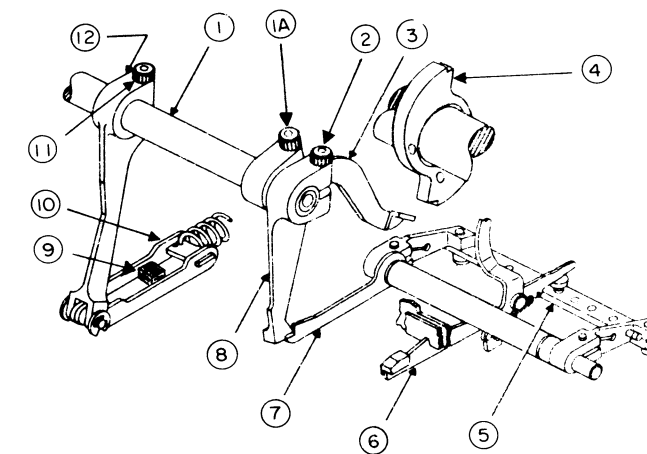

- 1 Print Shaft
- 1a Print Cam Follower Clamp Screw
- 2 Print Prevent Arm Clamp Screw
- 3 Print Cam Follower
- 4 Print Cam
- 5 Print Prevent Bail
- 6 Sensing Finger in Slides Pushes Bail Out
- 7 Print Prevent Bail Lever
- 8 Print Prevent Arm
- 9 Shock Pad
- 10 Print Spring Yoke
- 11 Print Spring Arm Clamp Screw
- 12 Print Spring Arm

Figure 5-41. Print Shaft Adjustment  
(Print Prevention)

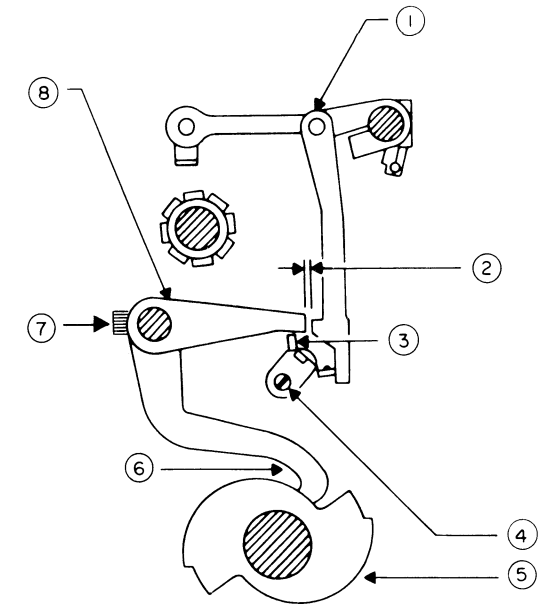

- 1 Hammer Shaft Arm
- 2 1/32 inch Clearance
- 3 Hammer Disconnect Link
- 4 Stop Screw
- 5 Print Cam
- 6 Print Cam Follower at Low Point of Cam
- 7 Print Cam Follower Clamp Screw
- 8 Print Shaft Terminal Lever

Figure 5-42. Print Linkage Adjustment

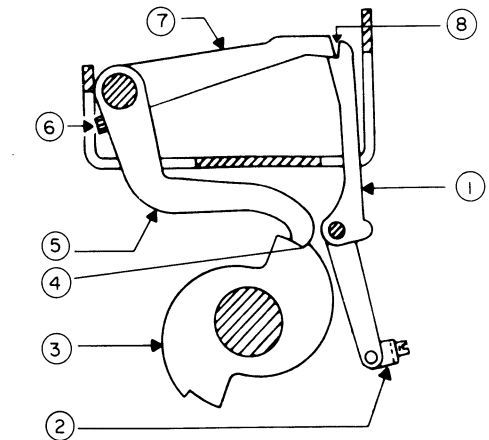

- 1 Print Prevent (Rod) Bail Lever
- 2 Print Prevent Bail Arm
- 3 Print Cam
- 4 Print Cam
- 5 Print Cam Follower
- 6 Print Prevent Arm Clamp Screw
- 7 Print Prevent Arm
- 8 Notch

Figure 5-43. Print Prevent Arm Engaged  
with Print Prevent Bail Lever

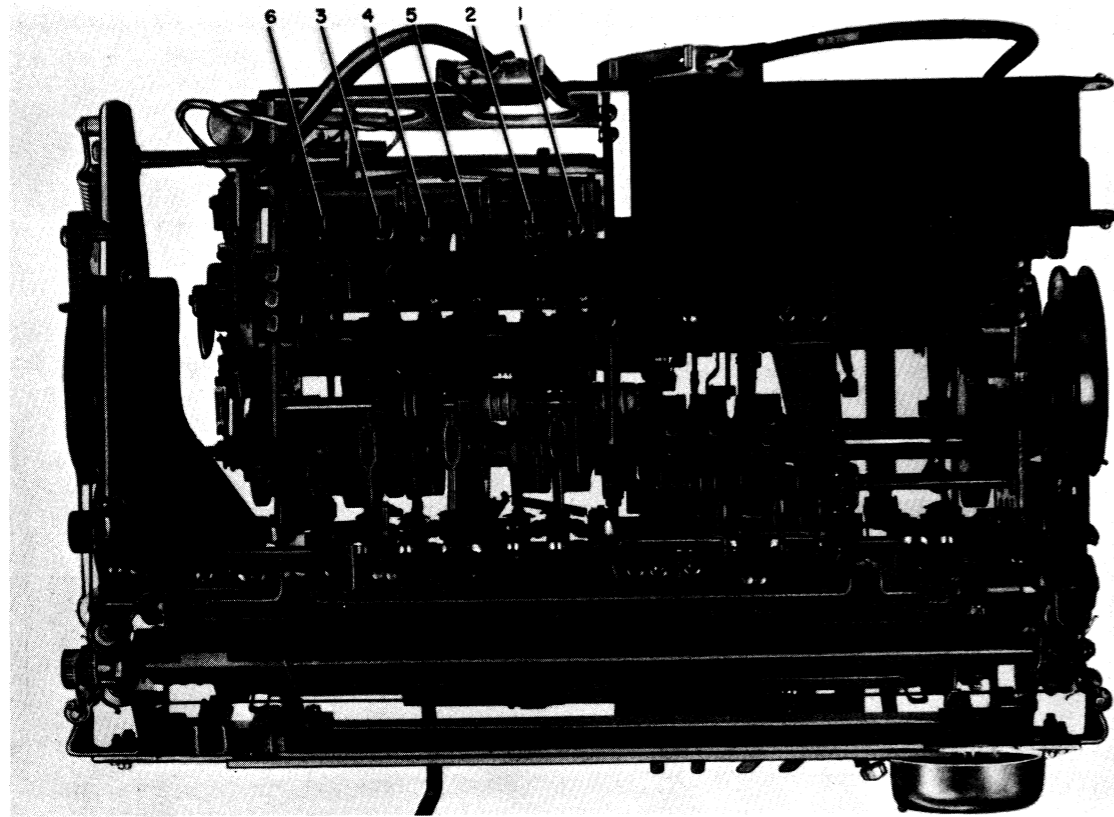

Figure 5-44. Magnetic Selector Adjustment

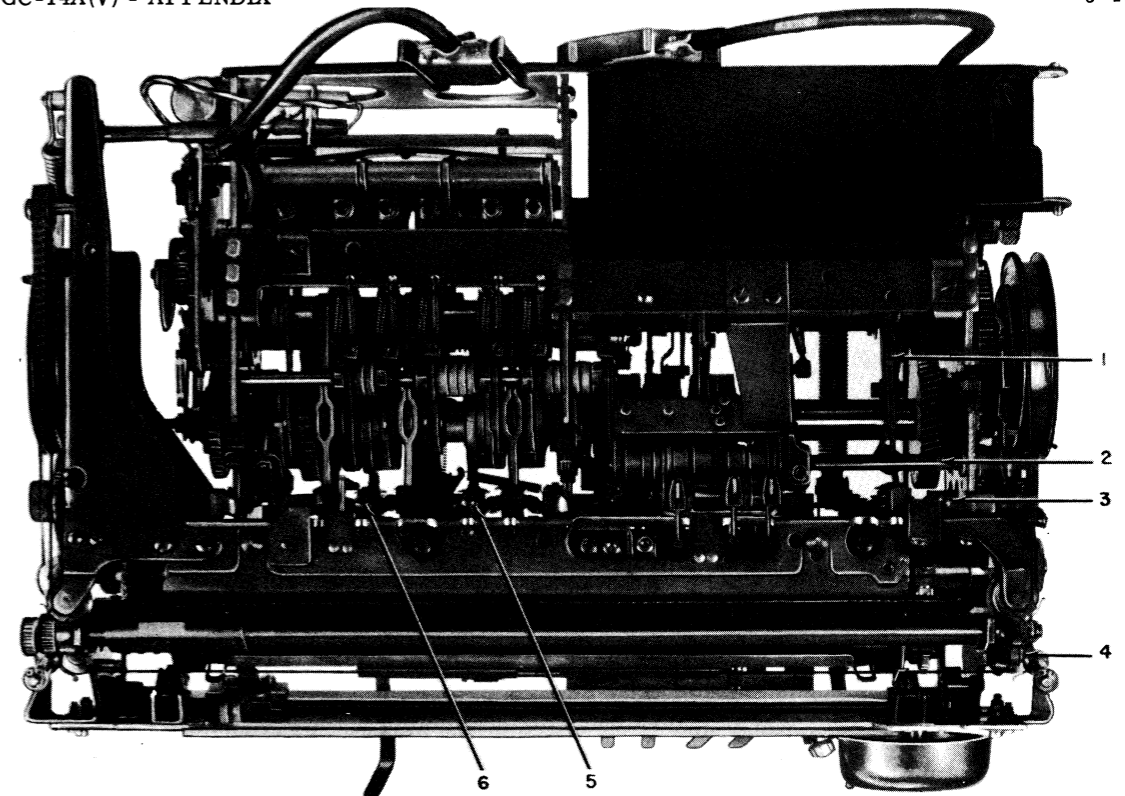

Figure 5-47. Top View of Printer, Ribbon Feed Mechanism Removed

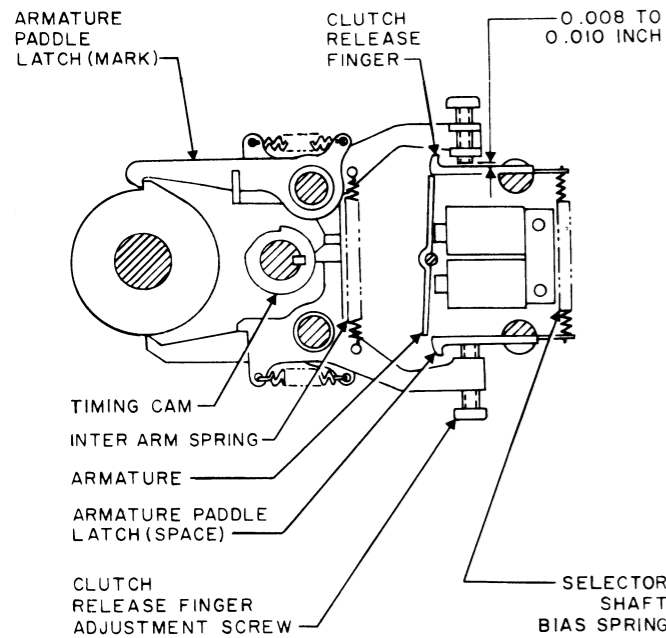

Figure 5-45. Selector Clutch Release Mechanism

LTRS-FIGS. CAM ON HIGH SIDE	1	2	A	W	J	^	U	Q	K	V	360°
	1	2	E	Z	D	B	S	Y	F	X	
LTRS-FIGS. CAM ON LOW SIDE	1	2	≡	L	R	G	I	P	C	V	180°
	1	2	≡	)	4	8	8	∅	:	;	
CAMS ON HIGH SIDE			≡	<	9	■	#	,	.		
	3	3	3	3							
	4	4			4	4					
	5		5		5	5					

Figure 5-46. Plan View of Print Cylinder

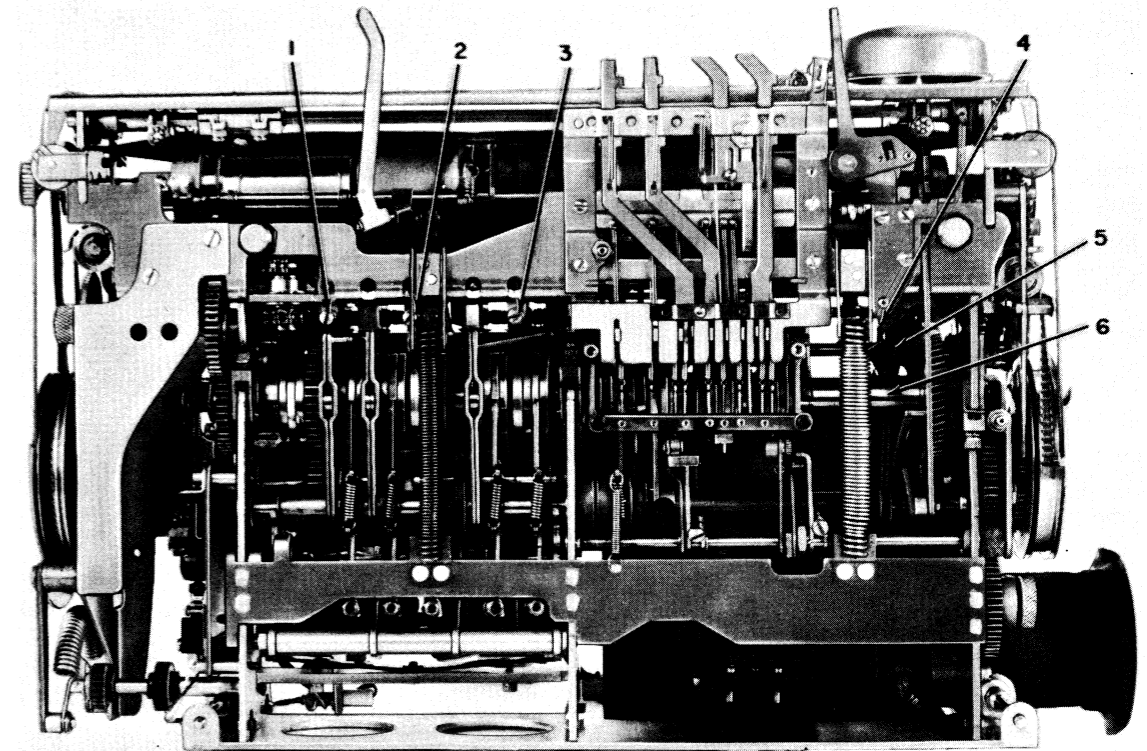

Figure 5-48. Bottom View of Printer

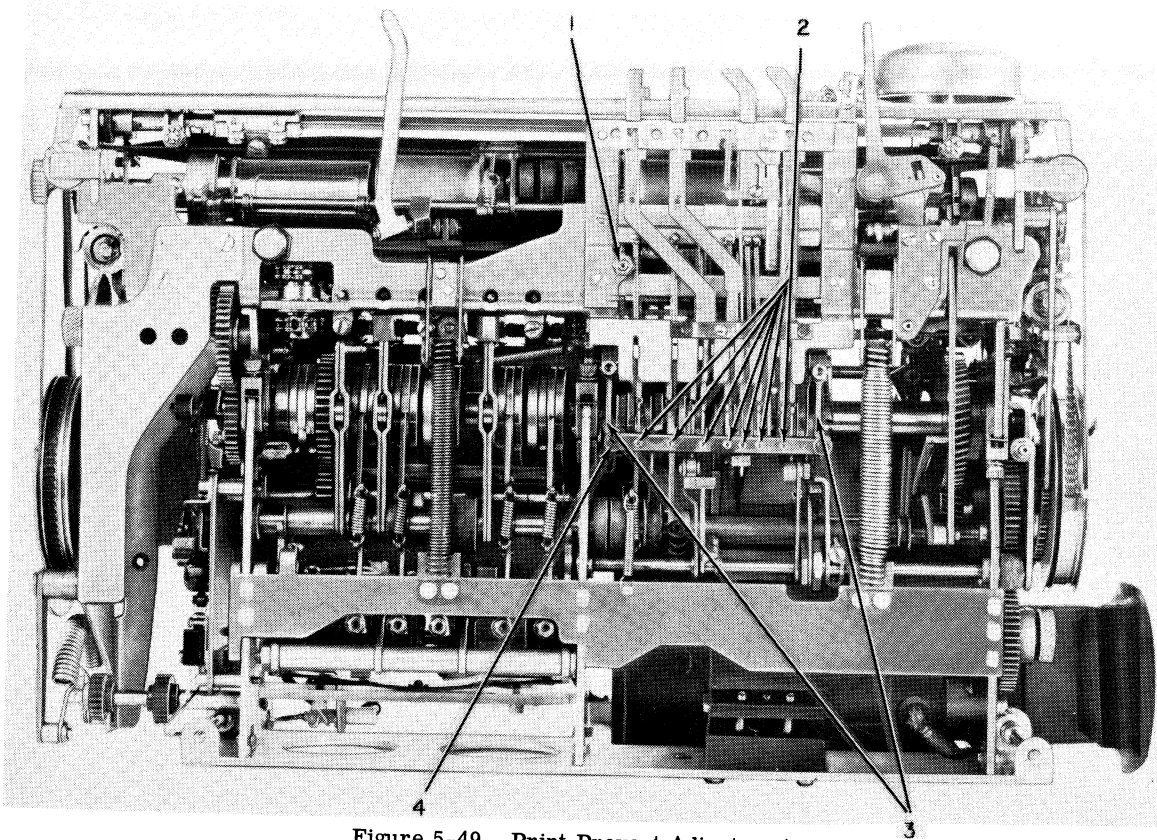

Figure 5-49. Print Prevent Adjustment

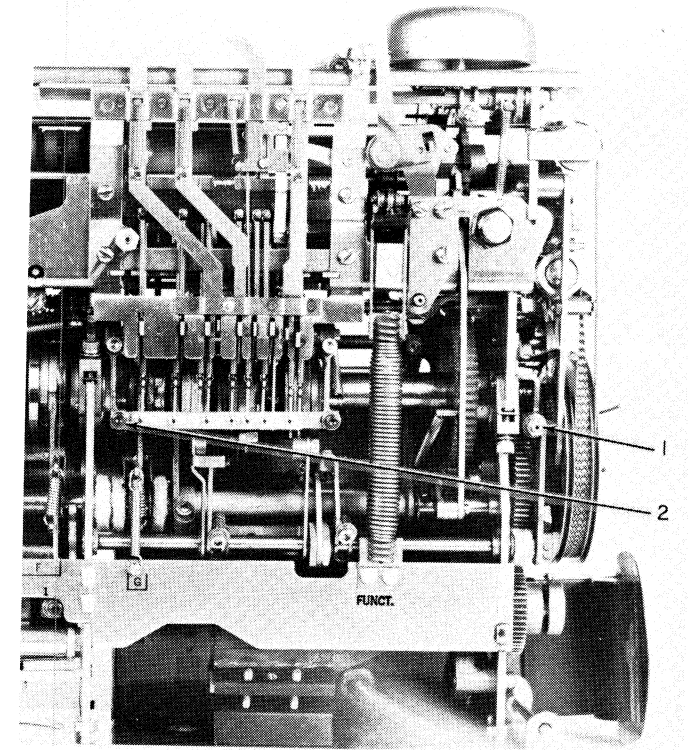

Figure 5-52. Spacing of the First Character

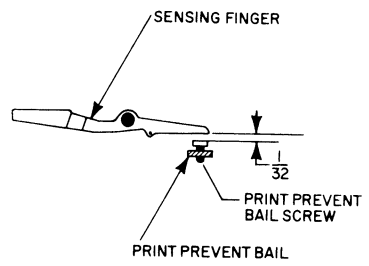

Figure 5-50. Print Prevent Adjustment

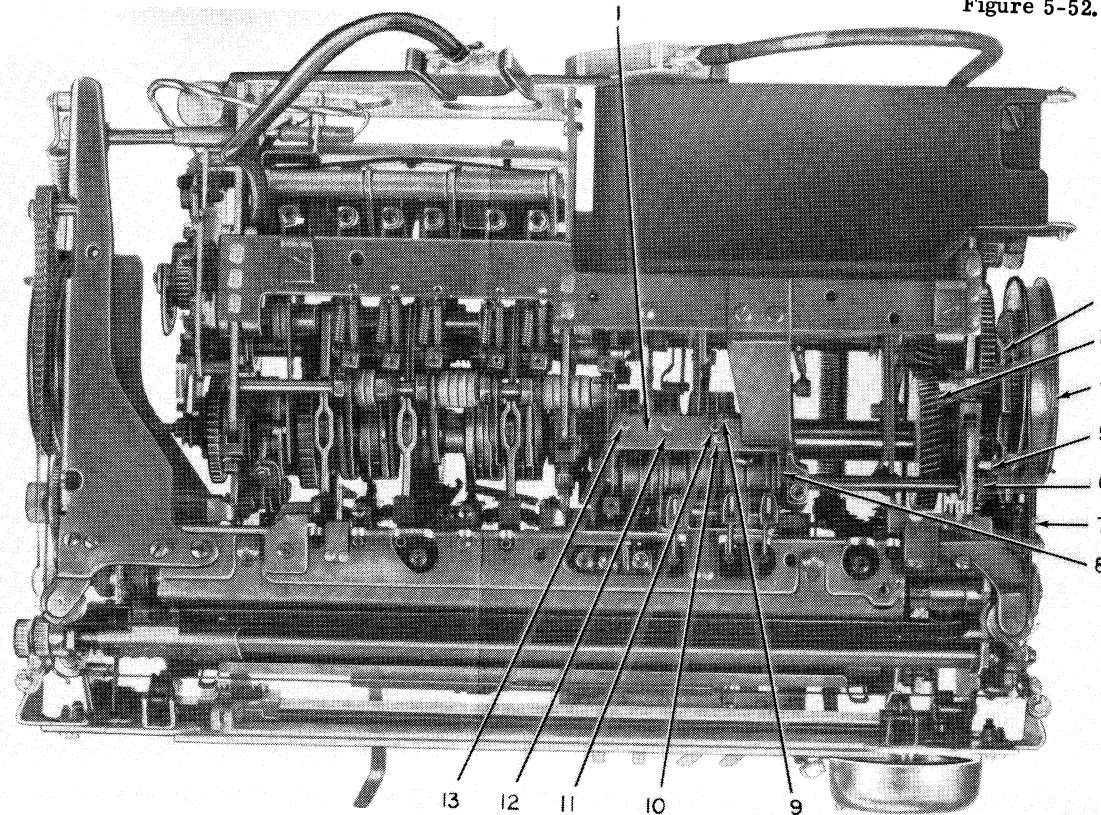

Figure 5-51. Advance Prevent and Bounce Prevent Adjustment

ORIGINAL

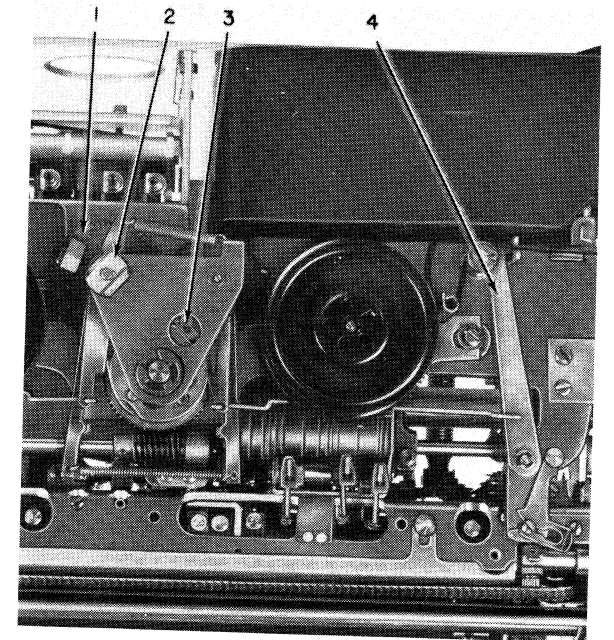

Figure 5-53. Ribbon Feed Adjustment

- 1 Time Delay Secondary Check Pawl Eccentric
- 2 Time Delay Secondary Check Pawl Stop Spring
- 3 Time Delay Secondary Check Pawl
- 4 Post
- 5 Advance Ratchet
- 6 Reduction Ratchet
- 7 Detent Spring Roller
- 8 Detent Spring
- 9 Timing Cam Shaft Extension
- 10 Time Delay Feed Pawl
- 11 Time Delay Feed Pawl Helical Spring
- 12 Time Delay Check Pawl Helical Spring
- 13 Time Delay Check Pawl
- 14 Time Delay Feed and Check Pawl Guide
- 15 Time Delay Latch
- 16 Time Delay Ratchet Support Shaft
- 17 Button
- 18 Time Delay Yoke
- 19 Time Delay Switch Actuator Roller
- 20 Time Delay Switch Actuator
- 21 Time Delay Switch
- 22 Screws

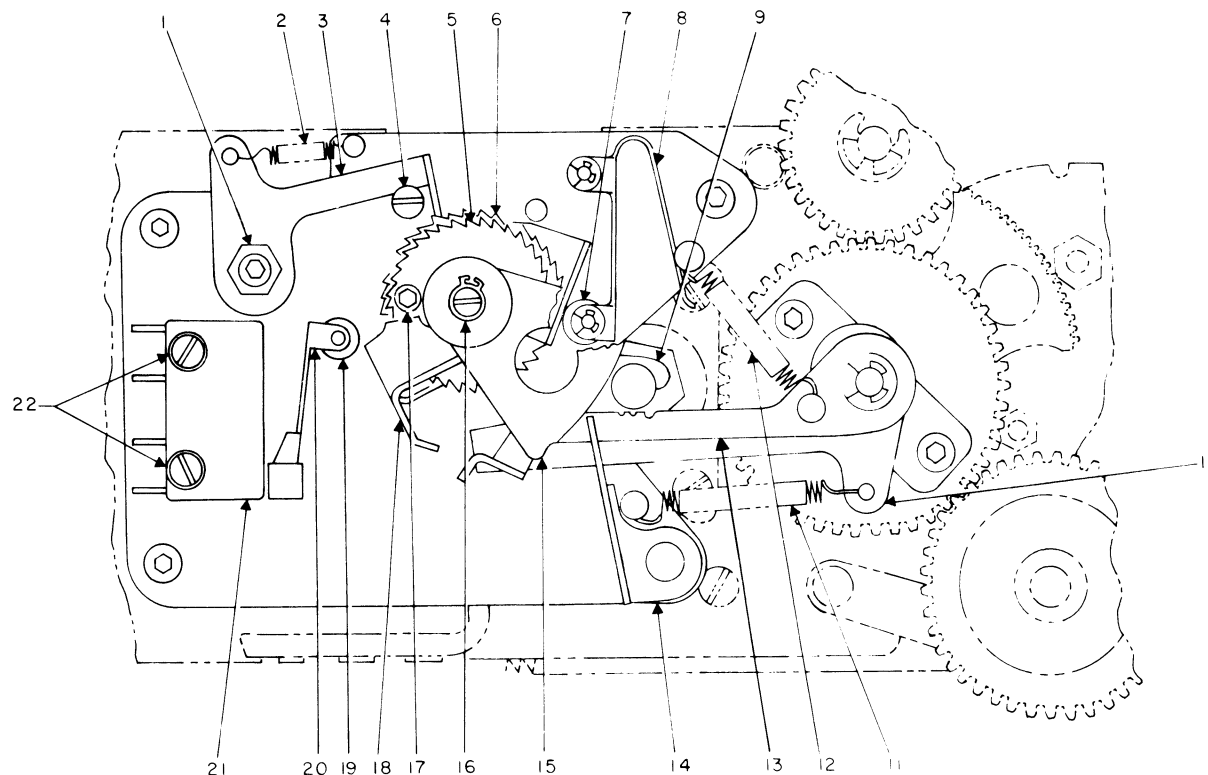

Figure 5-54. Time Delay Motor Stop Mechanism

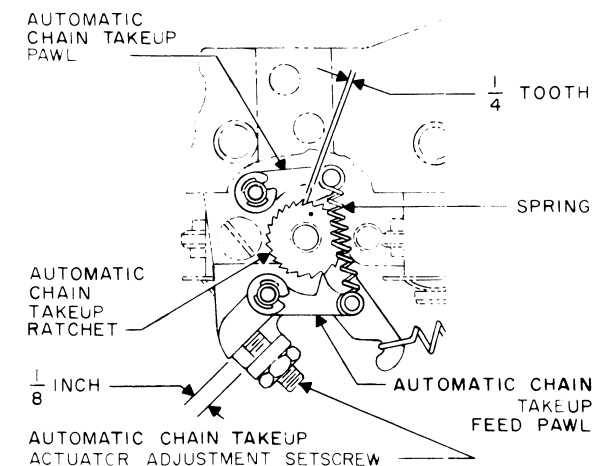

Figure 5-56. Automatic Lateral Chain Takeup Adjustment

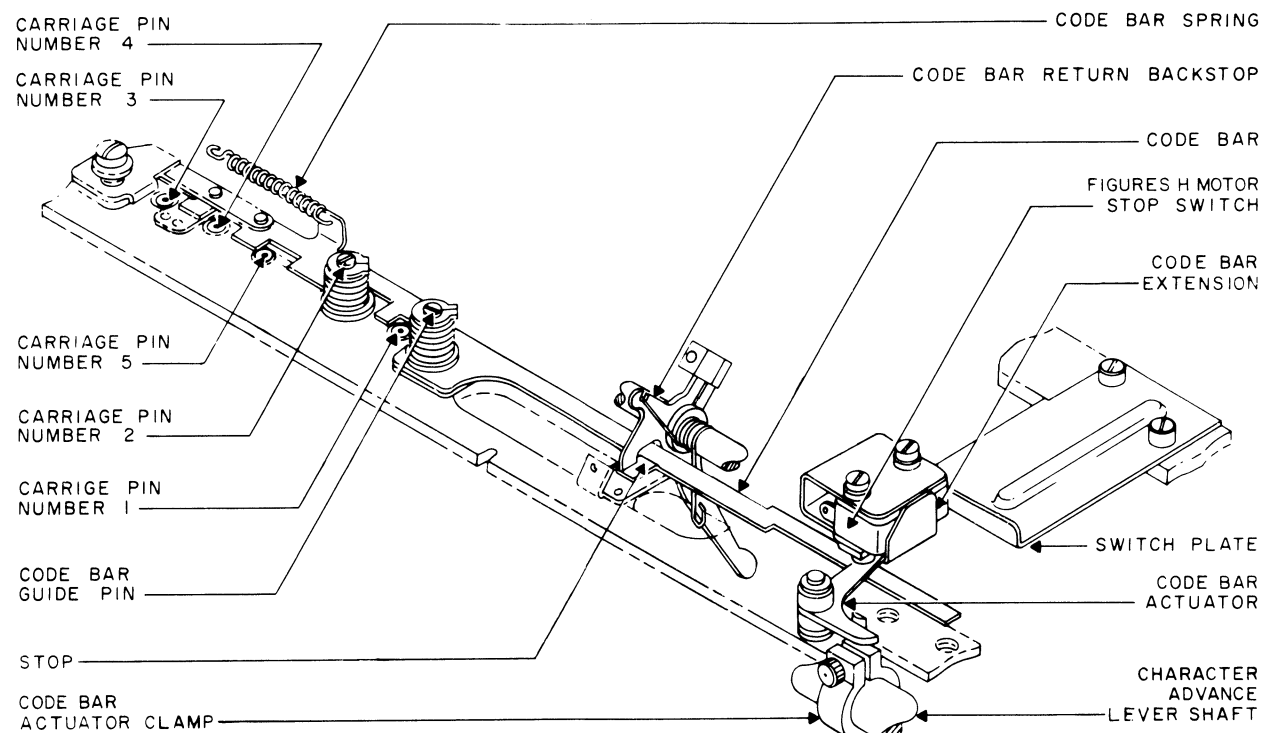
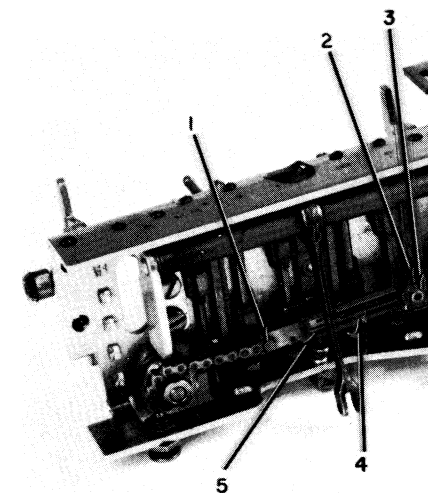

Figure 5-55. Figures H Motor Stop Adjustment



- 1 Adjustable Slide Link
- 2 Eccentric
- 3 Eccentric Lock Screw
- 4 Y Lever
- 5 Lever

Figure 5-57. Automatic Lateral Chain Takeup Adjustment

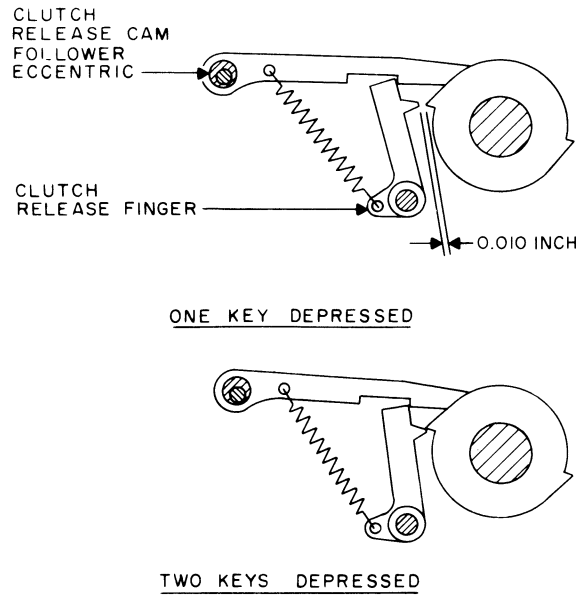

Figure 5-58. Clutch Release Lever Eccentric Adjustment

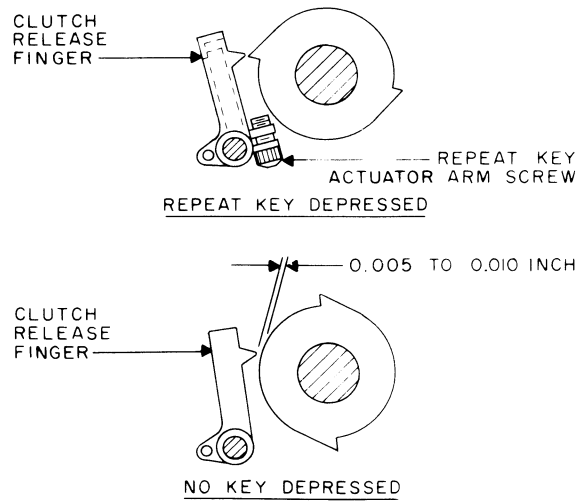

Figure 5-59. Repeat Key Clamp Arm Adjustment

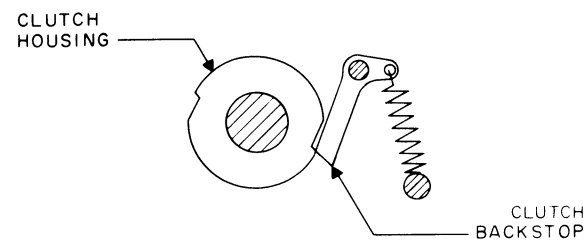

Figure 5-60. Backstop Eccentric Adjustment

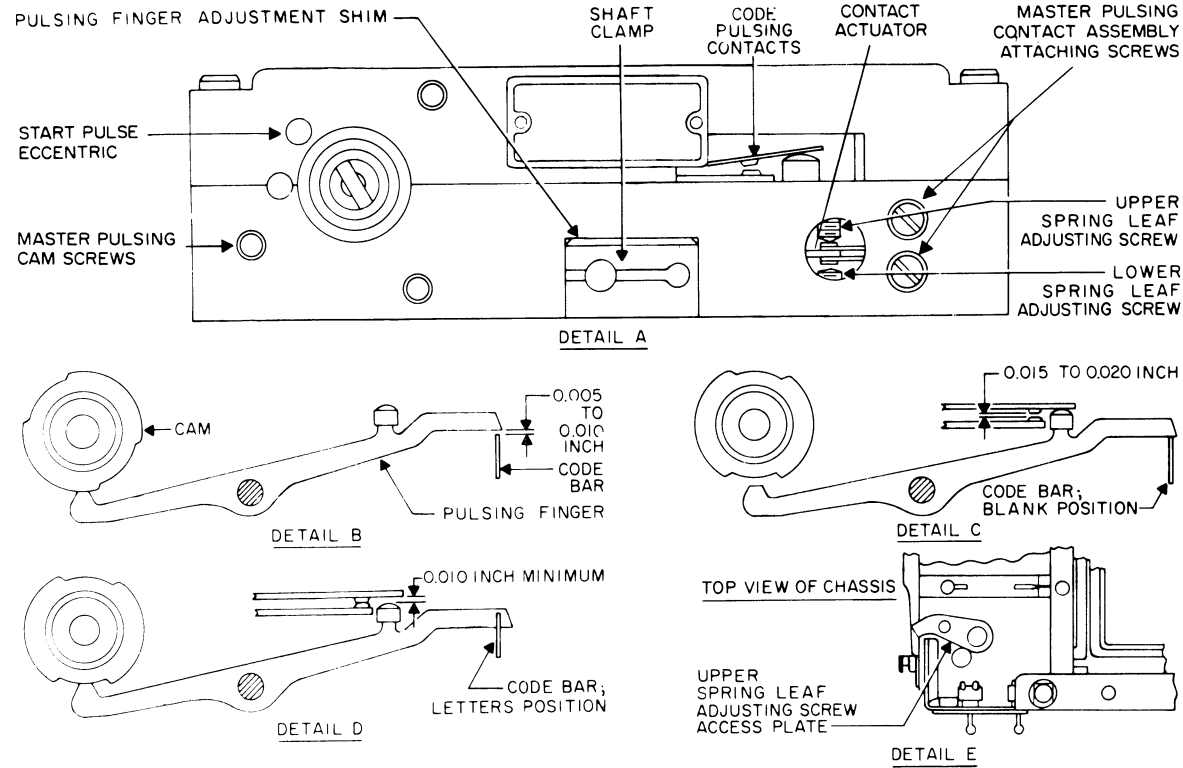

Figure 5-61. Keyboard Adjustment, Parts Location

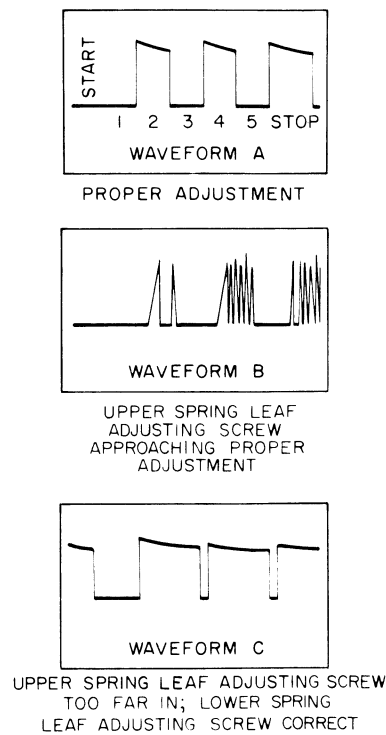

Figure 5-62. Waveforms for Transmitting Letters R

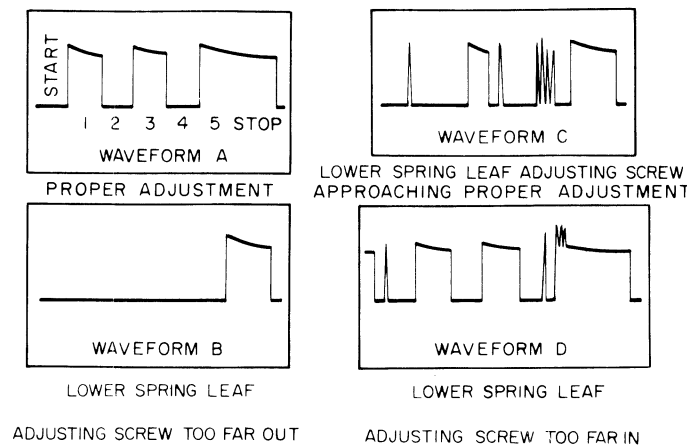

Figure 5-63. Waveforms for Transmitting Letters Y

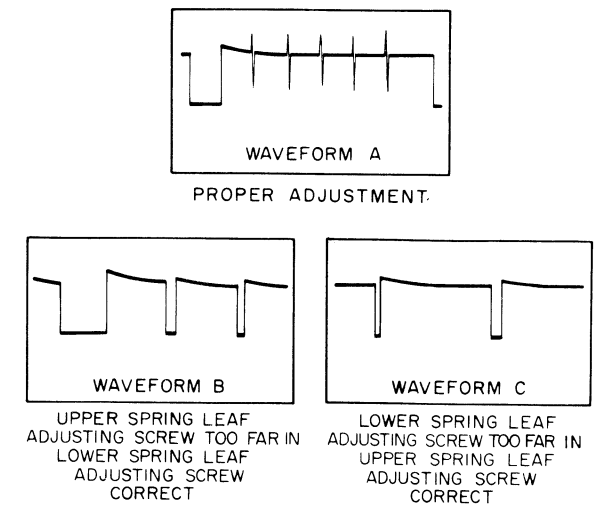

Figure 5-64. Waveforms for Transmitting Letters (LTRS)

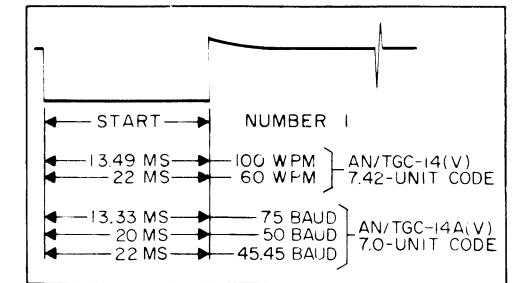

Figure 5-65. Waveform for Timing Adjustment

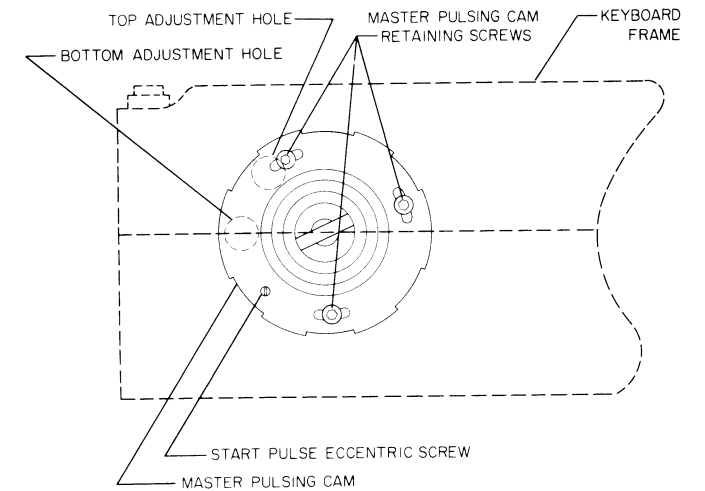

Figure 5-66. Keyboard Timing Adjustment

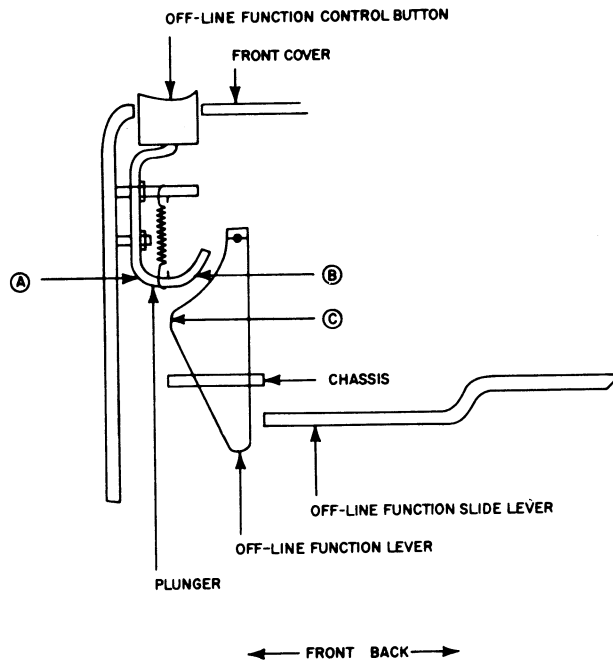

Figure 5-67. Off-Line Function Control Button Mechanism

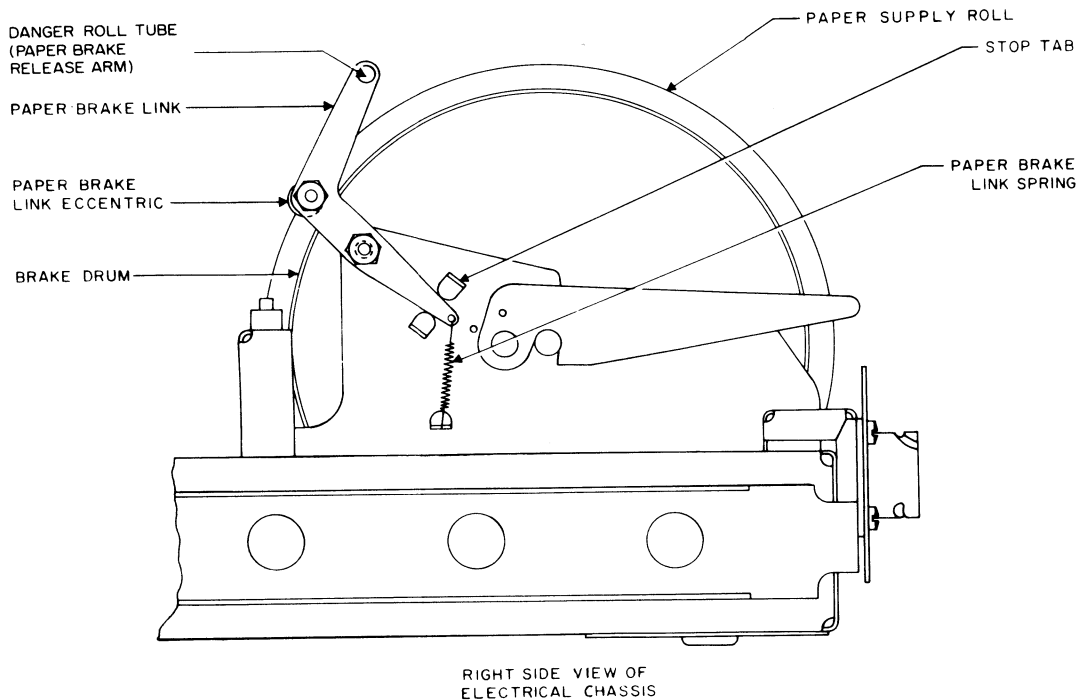
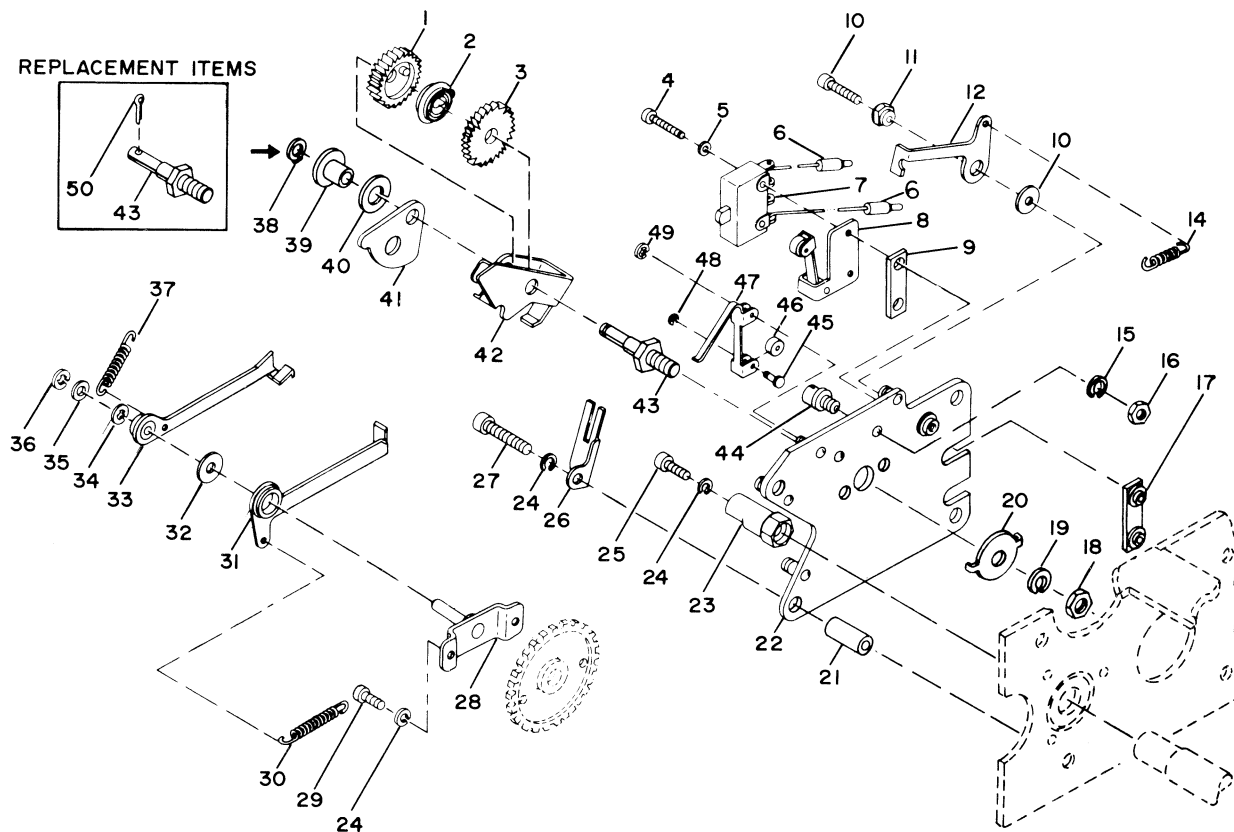

Figure 5-68. Paper Brake Adjustment, Parts Location



- 26 Guide, Time Delay Feed and Check Pawl
- 27 Screw
- 28 Adapter Assembly, Main Shaft Drive
- 29 Screw
- 30 Spring Time Delay Feed Pawl Helical
- 31 Pawl Assembly, Time Delay Feed
- 32 Spacer, Sleeve
- 33 Pawl Assembly, Time Delay Check
- 34 Ring, Retaining
- 35 Washer, Felt
- 36 Ring, Retaining
- 37 Spring, Time Delay Check Pawl Helical
- 38 Ring
- 39 Sleeve
- 40 Shim
- 41 Latch
- 42 Yoke
- 43 Shaft, Ratchet Support
- 44 Post
- 45 Pin
- 46 Roller
- 47 Spring
- 48 Ring, Retaining
- 49 Ring, Retaining
- 50 Pin, Cotter

- 1 Ratchet, Advance
- 2 Spring, Return Spiral
- 3 Ratchet, Reduction
- 4 Screw
- 5 Washer
- 6 Probe, Time Delay Switch
- 7 Switch, Time Delay
- 8 Actuator, Time Delay Switch
- 9 Spacer
- 10 Screw
- 11 Eccentric, Time Delay Secondary
- 12 Pawl, Time Delay Secondary Check
- 13 Spacer
- 14 Spring, Time Delay Secondary Check Pawl
- 15 Lock, Washer
- 16 Nut, Plain Hex
- 17 Plate, Nut
- 18 Nut, Lock
- 19 Washer, Lock
- 20 Lock, Ratchet Support Shaft
- 21 Spacer, Sleeve
- 22 Plate Assembly, Time Delay Mounting Base
- 23 Extension, Timing Cam Shaft
- 24 Washer, Lock
- 25 Screw

Figure 5-69. Automatic Time Delay Motor Stop Assembly  
SL-4-03315B Figure 16



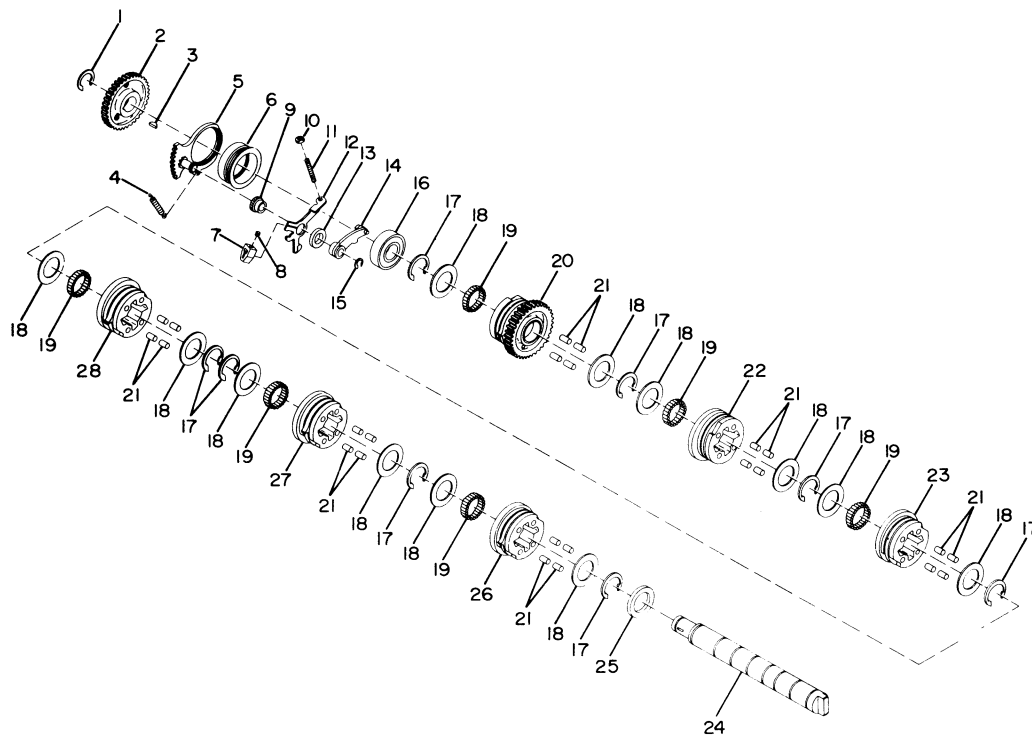

- |    |   |    |                                  |
|----|---|----|----------------------------------|
| 1  | Ring, Retaining                           | 15 | Ring, Retaining                  |
| 2  | Gear, Printer Helical                     | 16 | Bearing, Left-Hand               |
| 3  | Key, Woodruff                             | 17 | Ring, Retaining                  |
| 4  | Spring, Backstop Lever                    | 18 | Washer                           |
| 5  | Range, Adjustment Assembly                | 19 | Roller, Needle Bearing           |
| 6  | Retainer, Left-Hand Bearing               | 20 | Clutch Assembly, A Cam and Start |
| 7  | Clamp                                     | 21 | Roller                           |
| 8  | Screw, Clamp                              | 22 | Clutch, B Cam and Lateral No. 3  |
| 9  | Bushing, Start Clutch Backstop Eccentric  | 23 | Clutch, C Cam and Lateral No. 4  |
| 10 | Nut, Lock                                 | 24 | Shaft, Selector Main             |
| 11 | Setscrew, Start Clutch Release Adjustment | 25 | Spacer                           |
| 12 | Lever, Start Clutch Backstop              | 26 | Clutch, F Cam and Rotary No. 1   |
| 13 | Washer, Felt                              | 27 | Clutch, F Cam and Rotary No. 1   |
| 14 | Latch                                     | 28 | Clutch, D Cam and Lateral No. 5  |

Figure 5-70. Selector Main Shaft Assembly  
SL-4-03315B Figure 23

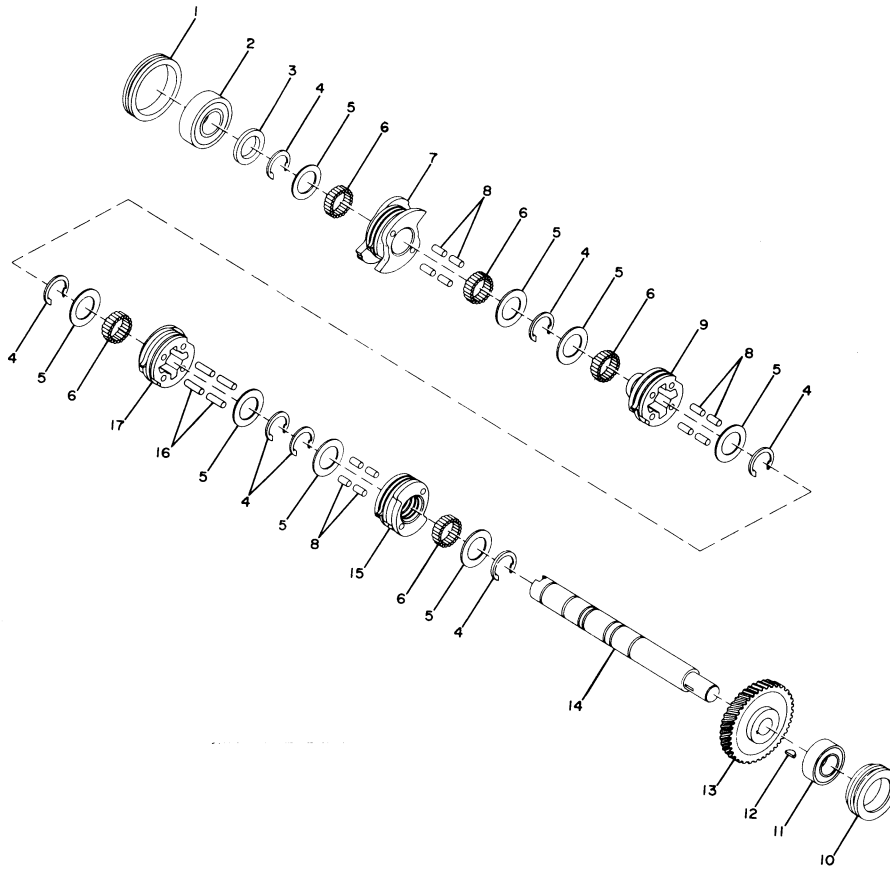

- |   |                                     |    |                                    |
|---|-------------------------------------|----|------------------------------------|
| 1 | Retainer, Center Bearing            | 10 | Retainer, Right-Hand Bearing       |
| 2 | Bearing, Center                     | 11 | Bearing, Right-Hand                |
| 3 | Spacer                              | 12 | Key, Third Reduction Gear          |
| 4 | Ring, Retaining                     | 13 | Gear, Third Reduction              |
| 5 | Washer, Flat                        | 14 | Shaft, Function Main               |
| 6 | Roller, Needle Bearing              | 15 | Clutch, K Cam, Carriage Return     |
| 7 | Clutch, G and H Cam, Print Function | 16 | Roller                             |
| 8 | Roller                              | 17 | Clutch, J Cam, Letters and Figures |
| 9 | Clutch, I Cam, Line Feed            |    |                                    |

Figure 5-71. Function Main Shaft Assembly  
SL-4-03315B Figure 22

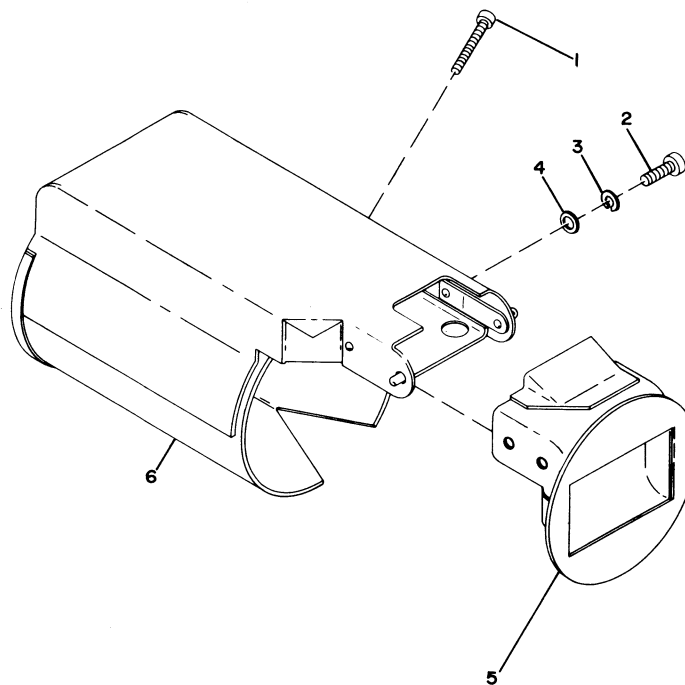

- |   |                           |   |                  |
|---|---------------------------|---|------------------|
| 1 | Screw, Machine (Clamping) | 4 | Washer           |
| 2 | Screw, Machine (Mounting) | 5 | Outlet, Cooling  |
| 3 | Washer, Lock              | 6 | Housing, Cooling |

Figure 5-72. Fan Outlet Duct Assembly  
SL-4-03315B Figure 17

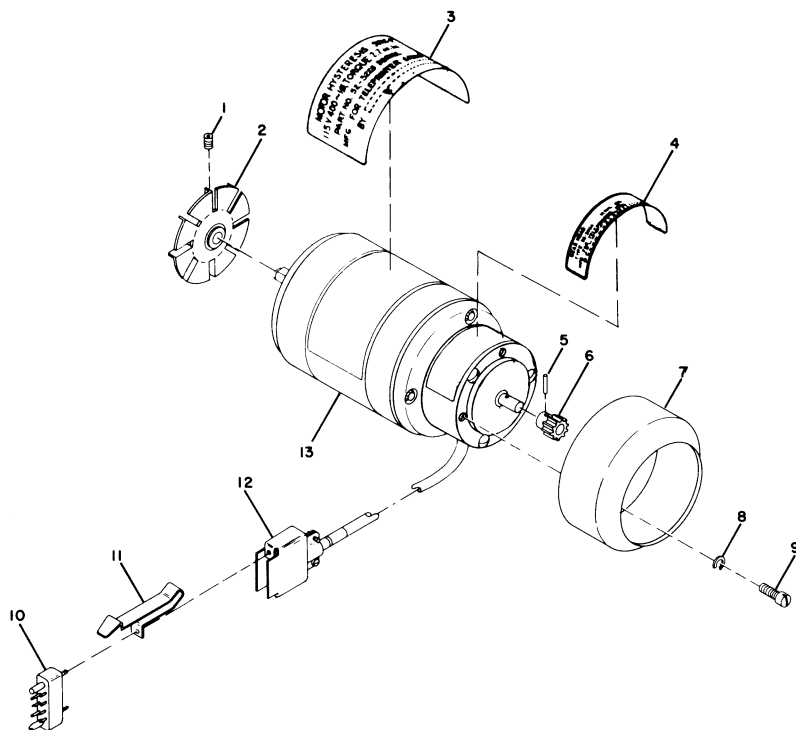

- |   |                     |    |                               |
|---|---------------------|----|-------------------------------|
| 1 | Setscrew, Motor Fan | 8  | Washer, Lock                  |
| 2 | Fan, Motor          | 9  | Screw                         |
| 3 | Motor, Decal        | 10 | Connector                     |
| 4 | Gear Head Decal     | 11 | Lock                          |
| 5 | Pin, Gear           | 12 | Hood                          |
| 6 | Motor, Pinion Gear  | 13 | Gear Head Assembly, Motor and |
| 7 | Cover, Motor        |    |                               |

Figure 5-73. Motor (400 Cycle) and Gearhead Assembly  
SL-4-03315B Figure 29

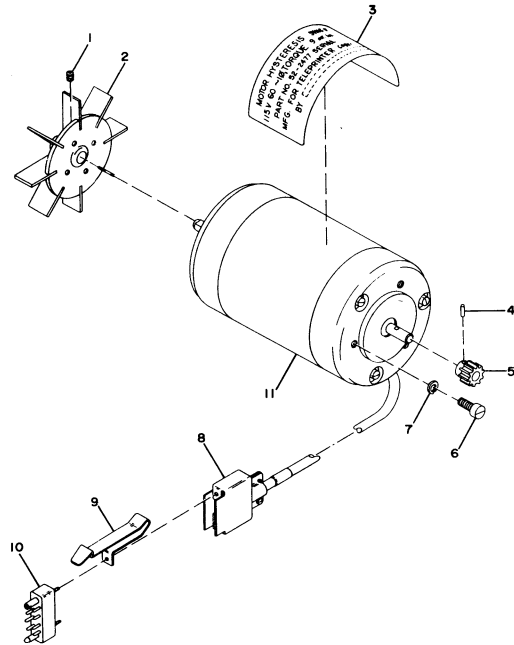

- |   |                     |    |                 |
|---|---------------------|----|-----------------|
| 1 | Setscrew, Motor Fan | 7  | Washer, Lock    |
| 2 | Fan, Motor          | 8  | Hood            |
| 3 | Motor Decal         | 9  | Lock            |
| 4 | Pin, Gear           | 10 | Connector       |
| 5 | Pinion, Gear        | 11 | Assembly, Motor |
| 6 | Screw               |    |                 |

Figure 5-74. Motor (60-Cycle) Assembly  
SL-4-03315B Figure 30

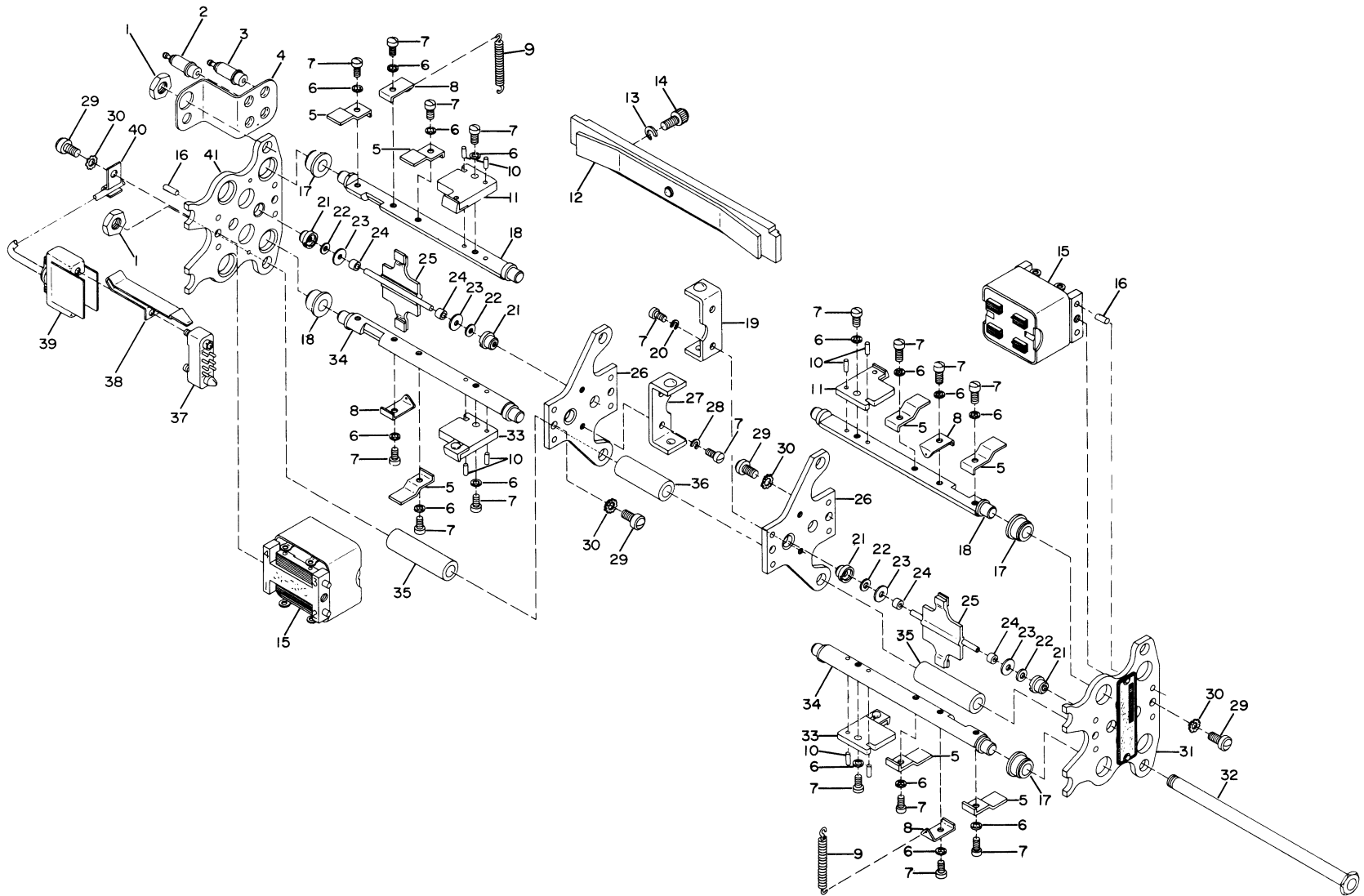

1	Nut	15	Magnet, Assembly Selector	29	Screw
2	Terminal	16	Pin	30	Washer, Lock
3	Terminal	17	Bearing, Shaft	31	Plate
4	Plate	18	Shaft, Selector Mark	32	Stud, Selector Tie Rod
5	Latch	19	Bar, Stop	33	Latch, Armature Space Paddle
6	Washer, Lock	20	Washer, Lock	34	Shaft, Selector Space
7	Screw, Machine	21	Bearing, Armature Shaft	35	Spacer, Outer Frame Plate
8	Arm, Selector Shaft Bias Spring	22	Washer, Lubricating Wick	36	Spacer, Inner Frame Plate
9	Spring, Selector Shaft Bias	23	Retainer, Lubricating Wick	37	Connector
10	Pin, Straight	24	Spacer, Armature Shaft	38	Lock
11	Latch, Armature Mark Paddle	25	Armature	39	Hood
12	Bar	26	Plate	40	Bracket, Cable Strain Relief
13	Washer, Lock	27	Bar, Stop	41	Plate
14	Screw, Machine	28	Washer, Lock		

Figure 5-75. Selector Assembly (AN/TGC-14(V) Only)  
SL-4-03315B Figure 18

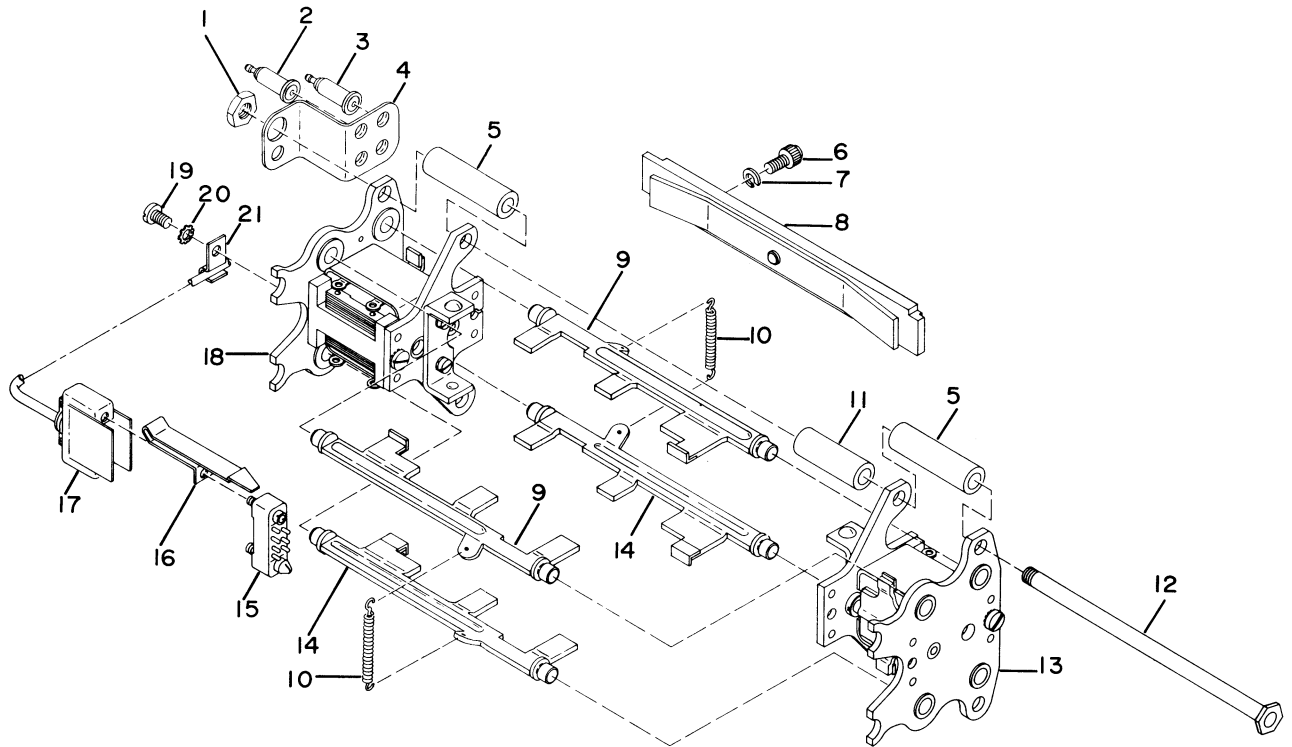

- |    |                             |    |                                   |
|----|-----------------------------|----|-----------------------------------|
| 1  | Nut                         | 12 | Stud, Selector Tie Rod            |
| 2  | Terminal                    | 13 | Frame Assembly, Right-Hand Magnet |
| 3  | Terminal                    | 14 | Shaft, Selector Space Latch       |
| 4  | Plate                       | 15 | Connector                         |
| 5  | Spacer, Outer Frame Plate   | 16 | Lock                              |
| 6  | Screw                       | 17 | Hood                              |
| 7  | Washer                      | 18 | Frame Assembly, Left-Hand Magnet  |
| 8  | Bar                         | 19 | Screw                             |
| 9  | Shaft, Selector Mark Latch  | 20 | Washer, Lock                      |
| 10 | Spring, Selector Shaft Bias | 21 | Bracket, Cable Strain Relief      |
| 11 | Spacer, Inner Frame Plate   |    |                                   |

Figure 5-76. Selector Assembly (AN/TGC-14A(V) Only)  
SL-4-03315B Figure 18A

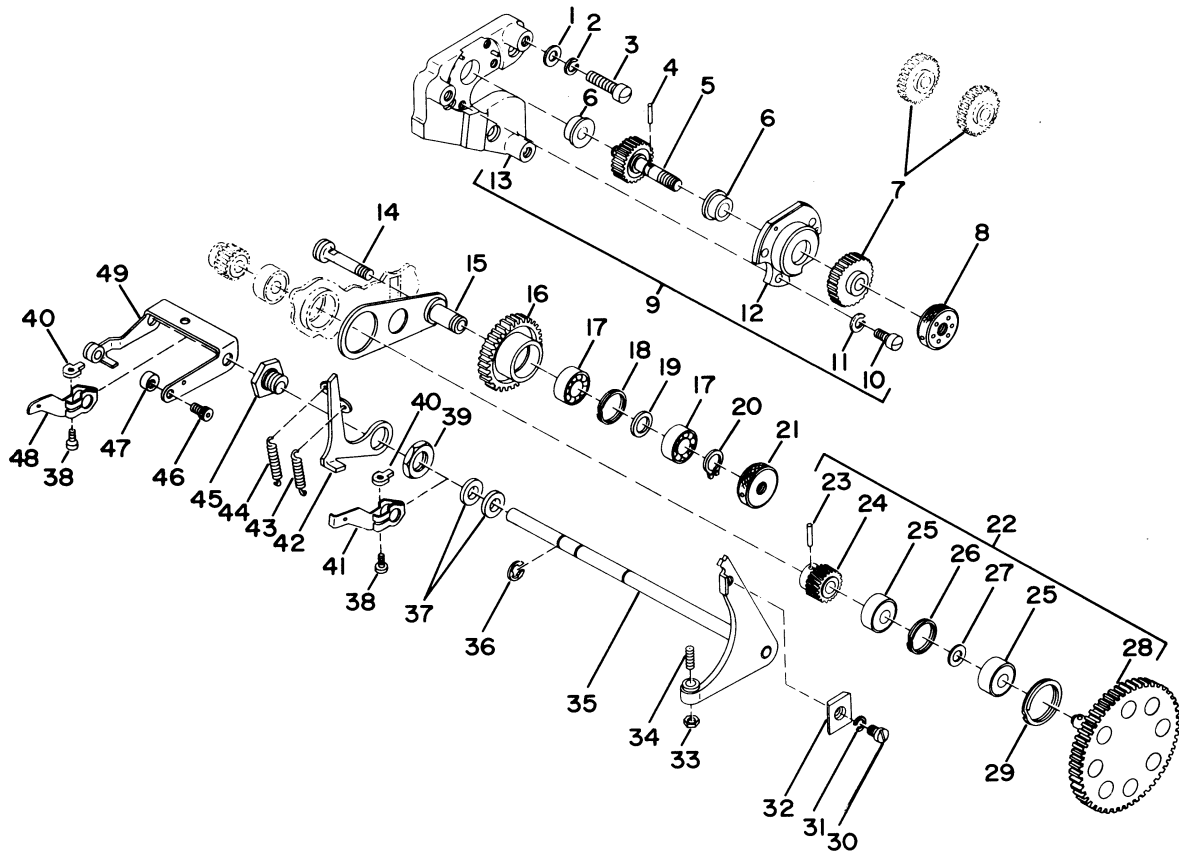

- |    |                                  |    |  |
|----|----------------------------------|----|--|
| 1  | Washer                           | 26 | Ring   |
| 2  | Washer, Lock                     | 27 | Spacer   |
| 3  | Screw                            | 28 | Gear, Second Reduction   |
| 4  | Pin                              | 29 | Ring   |
| 5  | Gear, First Reduction            | 30 | Screw  |
| 6  | Bearing                          | 31 | Washer, Lock   |
| 7  | Gear, Speed Change               | 32 | Stop, 72 Character   |
| 8  | Nut, Lock                        | 33 | Nut, Anti-Turn   |
| 9  | Mount Assembly, Motor            | 34 | Screw, First Character Adjustment  |
| 10 | Screw                            | 35 | Shaft, V Lever   |
| 11 | Washer, Lock                     | 36 | Ring, Retaining (4)  |
| 12 | Cup, Bearing                     | 37 | Washer, Felt   |
| 13 | Plate, Motor Mounting            | 38 | Screw  |
| 14 | Stud                             | 39 | Nut, Plain Hex   |
| 15 | Arm Assembly, Idler Gear         | 40 | Nut, Anti-Turn   |
| 16 | Gear, Idler                      | 41 | Arm, Lock Lever Actuator   |
| 17 | Bearing                          | 42 | Lock Lever   |
| 18 | Ring                             | 43 | Spring, Lock Lever Actuator Arm Helical                                  |
| 19 | Spacer                           | 44 | Spring, Automatic Carriage Return and<br>Line Feed Bail Actuator Helical |
| 20 | Ring, Grip                       | 45 | Bushing, Eccentric   |
| 21 | Nut, Lock                        | 46 | Screw  |
| 22 | Pinion Assembly, Third Reduction | 47 | Eccentric, Bail (Carriage Return)  |
| 23 | Pin                              | 48 | Arm, Automatic Carriage Return and<br>Line Feed Actuator                 |
| 24 | Pinion, Third Reduction          | 49 | Actuator   |
| 25 | Bearing                          |    |  |

Figure 5-77. Gear Train, Automatic Carriage Return,  
and Line Feed Assembly  
SL-4-03315B Figure 19



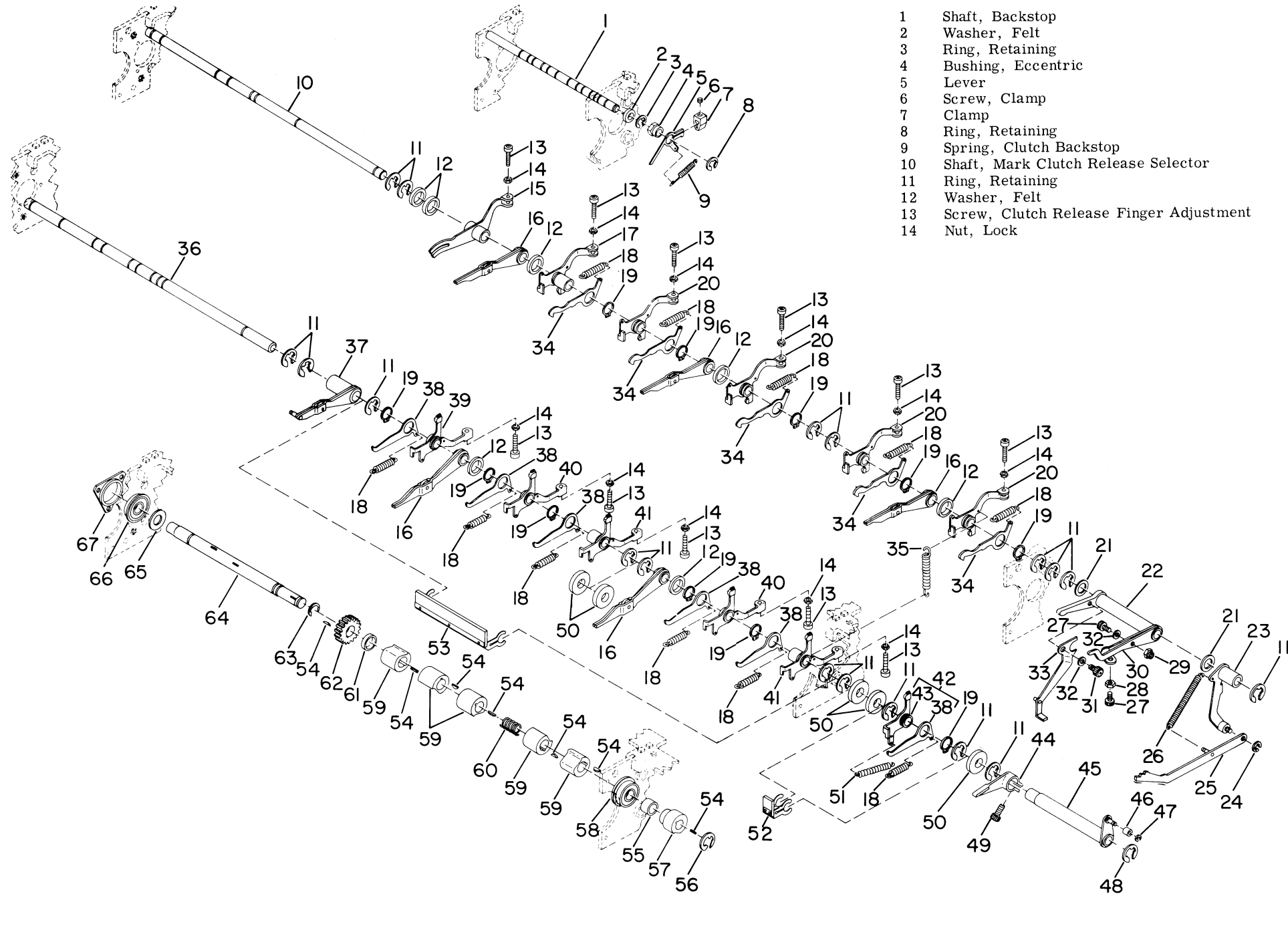

- |    |   |     |   |
|----|---|-----|---|
| 1  | Shaft, Backstop                         | 15  | Arm, Line Feed Cam Follower                                 |
| 2  | Washer, Felt                            | 16  | Follower, Type Positioning Cam                              |
| 3  | Ring, Retaining                         | 17  | Arm Assembly, Start Clutch Release                          |
| 4  | Bushing, Eccentric                      | 18  | Spring, Safety  |
| 5  | Lever                                   | 19  | Ring, Retaining   |
| 6  | Screw, Clamp                            | 20  | Arm Assembly, Mark Clutch Release                           |
| 7  | Clamp                                   | 21  | Washer, Felt  |
| 8  | Ring, Retaining                         | 22  | Follower Assembly, Letters Figures Cam                      |
| 9  | Spring, Clutch Backstop                 | 22A | Follower, (Letter Figures Pulley Carriage Actuator) and Cam |
| 10 | Shaft, Mark Clutch Release Selector     | 23  | Link, Line Feed Motion Amplify                              |
| 11 | Ring, Retaining                         | 24  | Ring, Retaining   |
| 12 | Washer, Felt                            | 25  | Pawl, Line Feed   |
| 13 | Screw, Clutch Release Finger Adjustment | 26  | Spring, Line Feed Pawl                                      |
| 14 | Nut, Lock                               | 27  | Screw   |
|    |   | 28  | Nut   |
|    |   | 29  | Nut   |
|    |   | 30  | Pulley Carriage Actuator                                    |
|    |   | 31  | Screw   |
|    |   | 32  | Washer  |
|    |   | 33  | Lever, Bell Prevent   |
|    |   | 34  | Finger, Mark Clutch Release                                 |
|    |   | 35  | Spring, Inter-Arm   |
|    |   | 36  | Shaft, Space Clutch Release Selector                        |
|    |   | 37  | Secondary No. 3 Cam Follower                                |
|    |   | 38  | Finger  |
|    |   | 39  | Arm, No. 3 Space Clutch Release                             |
|    |   | 40  | Arm, No. 2 and 4 Space Clutch Release                       |
|    |   | 41  | Arm, No. 1 and 5 Space Clutch Release                       |
|    |   | 42  | Release Assembly, Print and Function Clutch                 |
|    |   | 43  | Arm, Print Function Clutch Release                          |
|    |   | 44  | Arm, Line Feed Cam Follower                                 |
|    |   | 45  | Actuator, Line Feed Torque Tube                             |
|    |   | 46  | Roller  |
|    |   | 47  | Ring, Retaining   |
|    |   | 48  | Ring, Retaining   |
|    |   | 49  | Screw, Clamping   |
|    |   | 50  | Washer, Felt  |
|    |   | 51  | Spring, Print and Function Clutch Release Arm               |
|    |   | 52  | Wick, Function Timing Cam                                   |
|    |   | 53  | Wick, Timing Cam  |
|    |   | 54  | Key   |
|    |   | 55  | Spacer  |
|    |   | 56  | Ring, Bowed Retaining                                       |
|    |   | 57  | Cam, Function Clutch Release                                |
|    |   | 58  | Bearing   |
|    |   | 59  | Cam, Timing   |
|    |   | 60  | Spring  |
|    |   | 61  | Spacer  |
|    |   | 62  | Gear, Timing Cam Shaft                                      |
|    |   | 63  | Ring, Retaining   |
|    |   | 64  | Shaft, Timing Cam   |
|    |   | 65  | Spacer  |
|    |   | 66  | Bearing   |
|    |   | 67  | Retainer, Bearing   |

Figure 5-78. Mark and Space Clutch Release Shaft, Timing Cam Shaft, and Backstop Shaft Assembly  
SL-4-03315B Figure 20

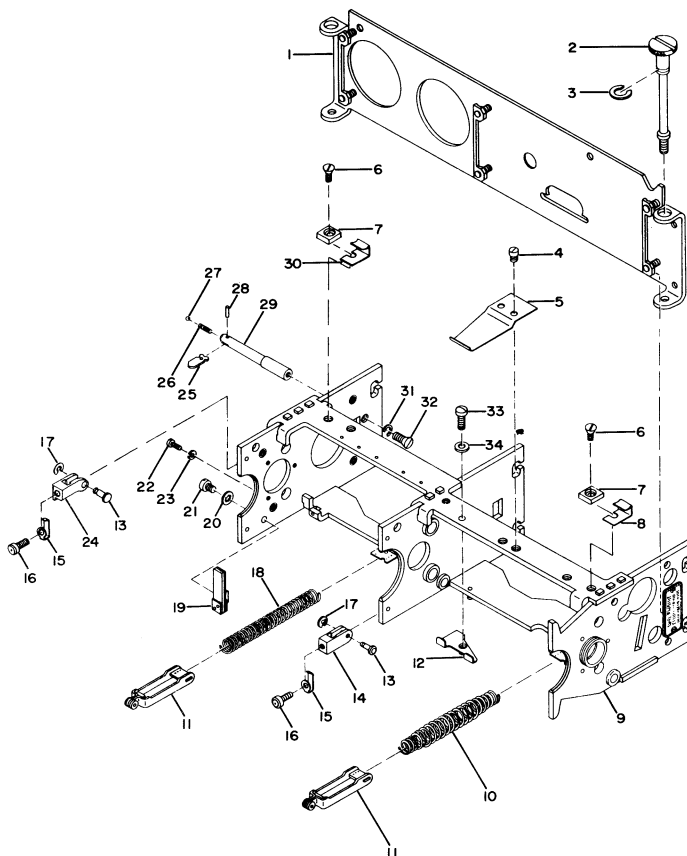

- |    |  |    |                                      |
|----|--|----|--------------------------------------|
| 1  | Plate, Back  | 18 | Spring, Print Helical                |
| 2  | Screw, Rear Lock   | 19 | Wick Assembly, Start Cam Lubricating |
| 3  | Ring, Retaining  | 20 | Washer, Lock                         |
| 4  | Screw  | 21 | Screw                                |
| 5  | Spring, Stop   | 22 | Screw, Machine                       |
| 6  | Screw, Machine   | 23 | Washer, Lock                         |
| 7  | Block  | 24 | Clamp, Frame (Top)                   |
| 8  | Clip, Ribbon Feed Base Spring                            | 25 | Arm, Lock                            |
| 9  | Frame, Rear  | 26 | Spring, Detent Helical               |
| 10 | Spring, Function Helical                                 | 27 | Ball, Detent                         |
| 11 | Link Assembly, Print and Function<br>Helical Spring Yoke | 28 | Pin                                  |
| 12 | Clip, Backstop Spring                                    | 29 | Post, Change Gear                    |
| 13 | Pivot, Stud  | 30 | Clip Ribbon Feed Base Spring         |
| 14 | Clamp, Frame   | 31 | Washer, Lock                         |
| 15 | Pad  | 32 | Screw                                |
| 16 | Screw  | 33 | Screw                                |
| 17 | Ring, Retaining  | 34 | Washer                               |

Figure 5-79. Rear Frame Assembly  
SL-4-03315B Figure 21

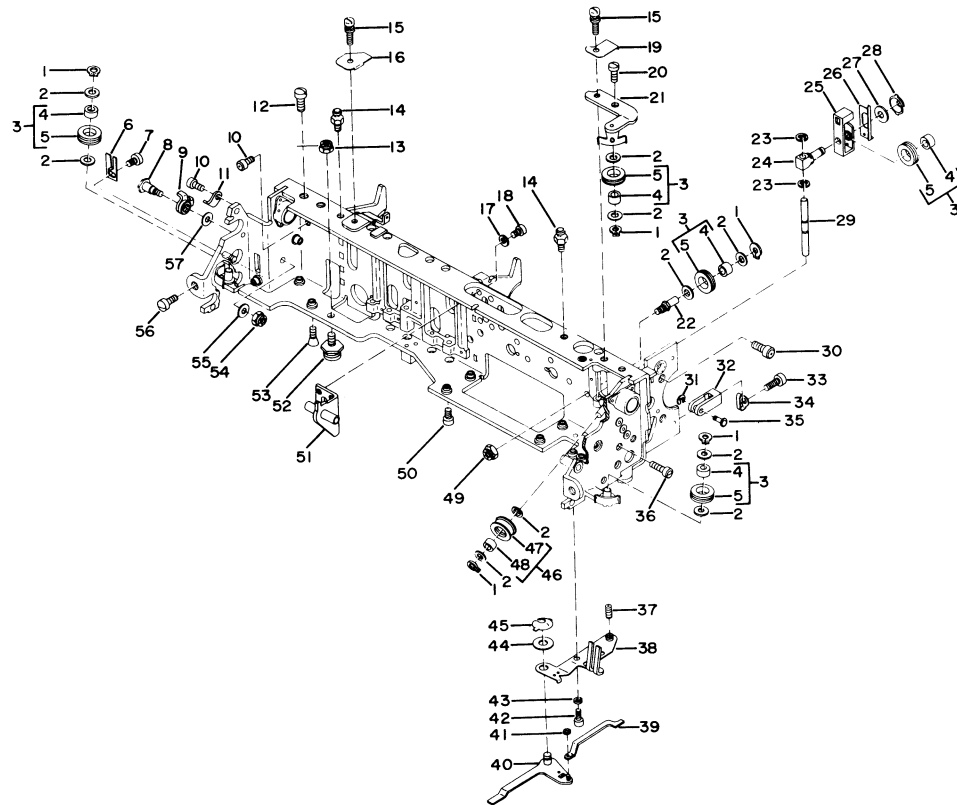

- |    |  |    |  |
|----|--|----|--|
| 1  | Ring, Retaining                          | 30 | Screw  |
| 2  | Spacer, Sleeve                           | 31 | Ring, Retaining  |
| 3  | Pulley Assembly                          | 32 | Clamp, Frame   |
| 4  | Bearing                                  | 33 | Screw  |
| 5  | Pulley                                   | 34 | Pad  |
| 6  | Bracket Print Hammer Actuator Link Guide | 35 | Pivot, Clamp   |
| 7  | Screw, Machine                           | 36 | Screw  |
| 8  | Shaft, Print Hammer Release              | 37 | Screw, Shift Lever Adjustment  |
| 9  | Release Print Hammer                     | 38 | Bracket, Shift   |
| 10 | Screw                                    | 39 | Shift, Line Feed   |
| 11 | Lever, Print Hammer Release Stop         | 40 | Arm Line Feed Shift  |
| 12 | Screw, Machine                           | 41 | Ring, Retaining  |
| 13 | Nut, Lock                                | 42 | Screw  |
| 14 | Pin, Paper Guide Retaining               | 43 | Washer, Lock   |
| 15 | Screw                                    | 44 | Washer   |
| 16 | Cover Left-Hand Guide                    | 45 | Ring, Grip   |
| 17 | Washer, Lock                             | 46 | Pulley Assembly, Lateral Control Belt                                      |
| 18 | Screw, Machine                           | 47 | Pulley   |
| 19 | Cover, Right-Hand Guide                  | 48 | Bearing  |
| 20 | Screw                                    | 49 | Nut  |
| 21 | Bracket                                  | 50 | Screw  |
| 22 | Pin                                      | 51 | Bracket Assembly, Print Lever and<br>Character Advance Lever Shaft Support |
| 23 | Ring, Retaining                          | 52 | Locator, Printing Electrical Chassis                                       |
| 24 | Rod                                      | 53 | Screw, Machine   |
| 25 | Carriage, Pulley                         | 54 | Nut, Self-Locking  |
| 26 | Clip, Spring                             | 55 | Washer, Flat   |
| 27 | Spacer, Sleeve                           | 56 | Screw, Machine   |
| 28 | Ring, Retaining                          | 57 | Washer   |
| 29 | Pin, Straight                            |    |  |

Figure 5-80. Front Frame Assembly (Front View)  
SL-4-03315B Figure 15

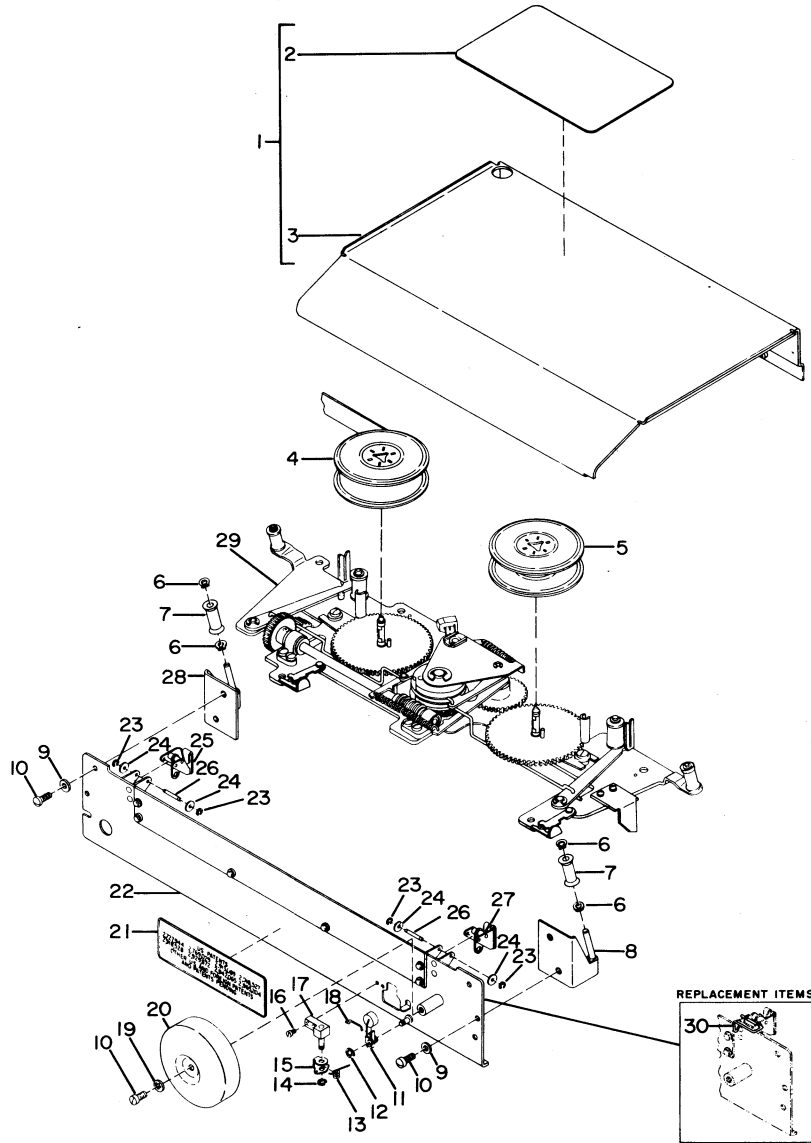

- |    |                                  |    |  |
|----|----------------------------------|----|--|
| 1  | Guide Assembly, Paper            | 17 | Bracket & Shaft Assembly   |
| 2  | Diagram, Ribbon Threading Guide  | 18 | Link, Wire   |
| 3  | Guide                            | 19 | Washer, Lock   |
| 4  | Ribbon and Spool                 | 20 | Bell   |
| 5  | Spool, Ribbon                    | 21 | Plate, Patent  |
| 6  | Ring, Retaining                  | 22 | Plate Assembly, Front  |
| 7  | Roller, Ribbon Guide             | 23 | Ring, Retaining  |
| 8  | Bracket, Right-Hand Ribbon Guide | 24 | Washer, Felt   |
| 9  | Washer, Flat                     | 25 | Guide Assembly, Left-Hand Ribbon Vibrator                                  |
| 10 | Screw, Machine                   | 26 | Shaft Ribon Vibrator Pivot   |
| 11 | Lever Assembly, End of Line Bell | 27 | Guide Assembly, Right-Hand Ribbon Vibrator                                 |
| 12 | Ring, Retaining                  | 28 | Bracket, Left-Hand Ribbon Guide  |
| 13 | Spring, Torsion                  | 29 | Plate Assembly, Ribbon Feed Top (see figure 5-39, Appendix, for breakdown) |
| 14 | Ring, Retaining                  | 30 | Spring Clip  |
| 15 | Lever                            |    |  |
| 16 | Screw, Machine                   |    |  |

Figure 5-81. Ribbon Feed and Front Plate Assemblies  
SL-4-03315B Figure 8

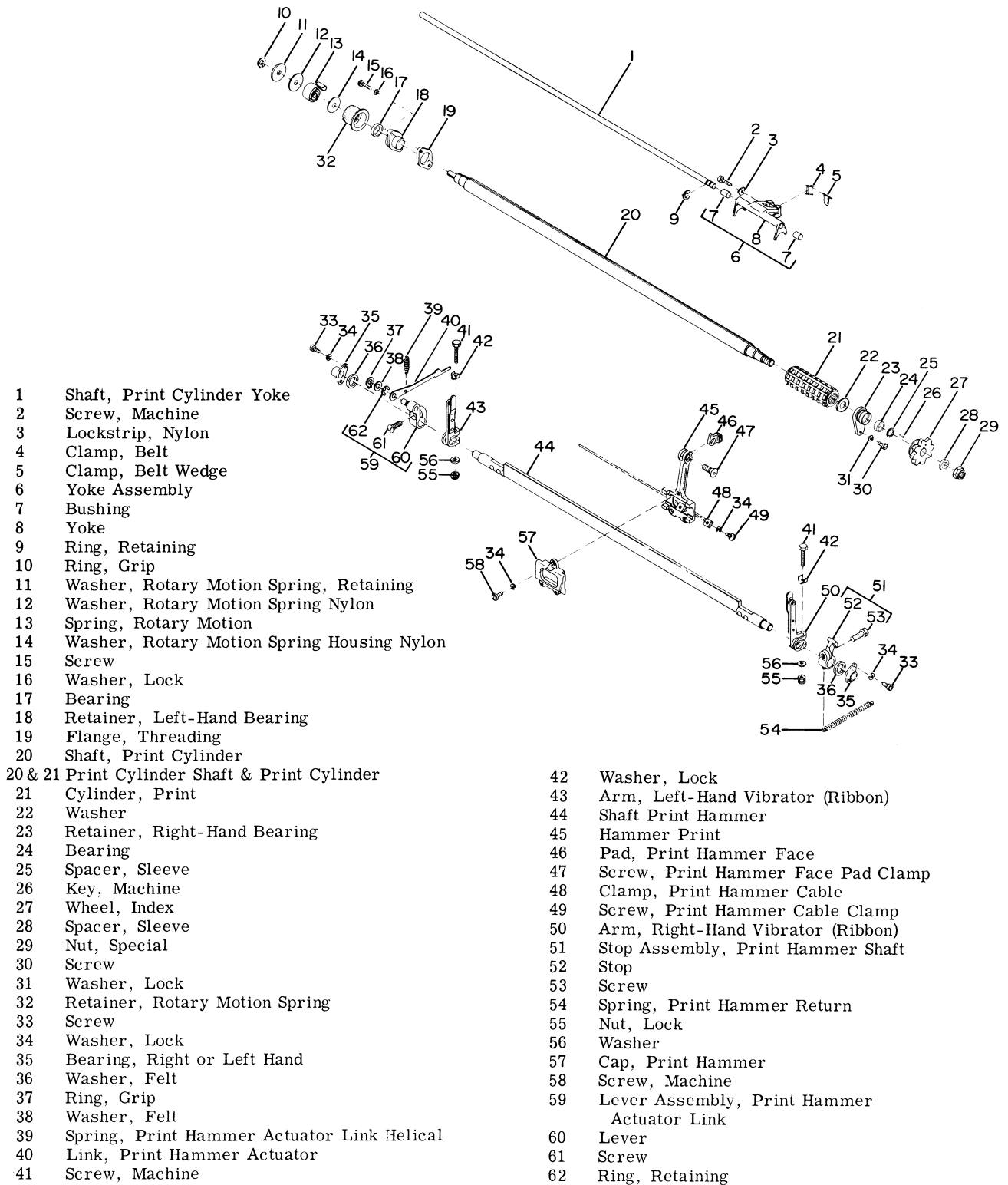
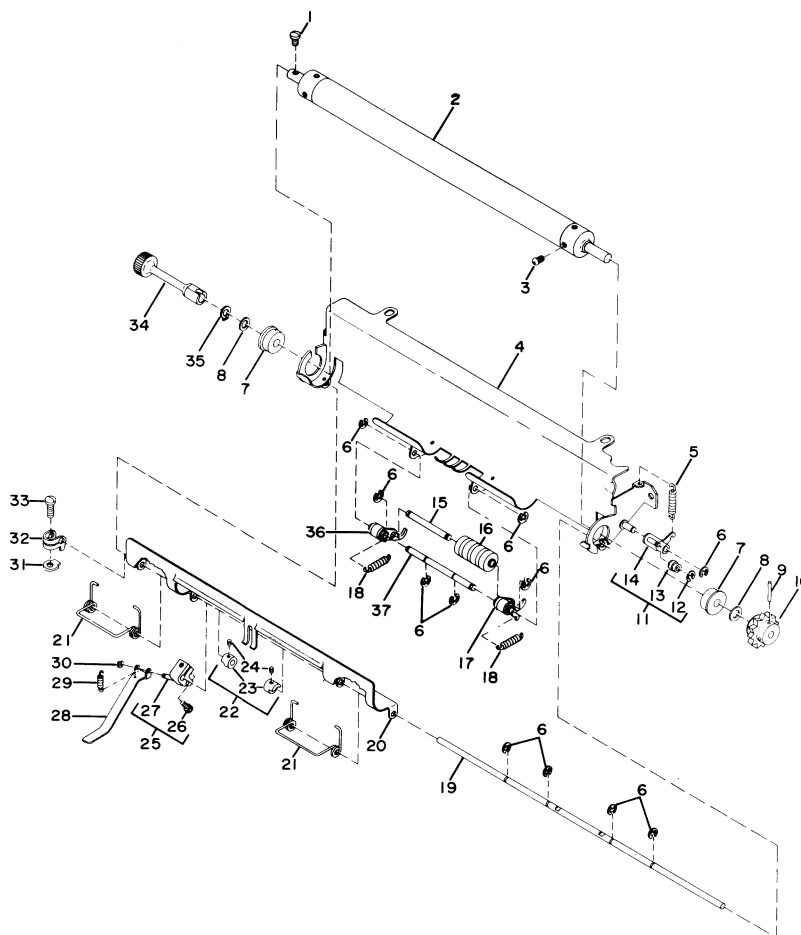
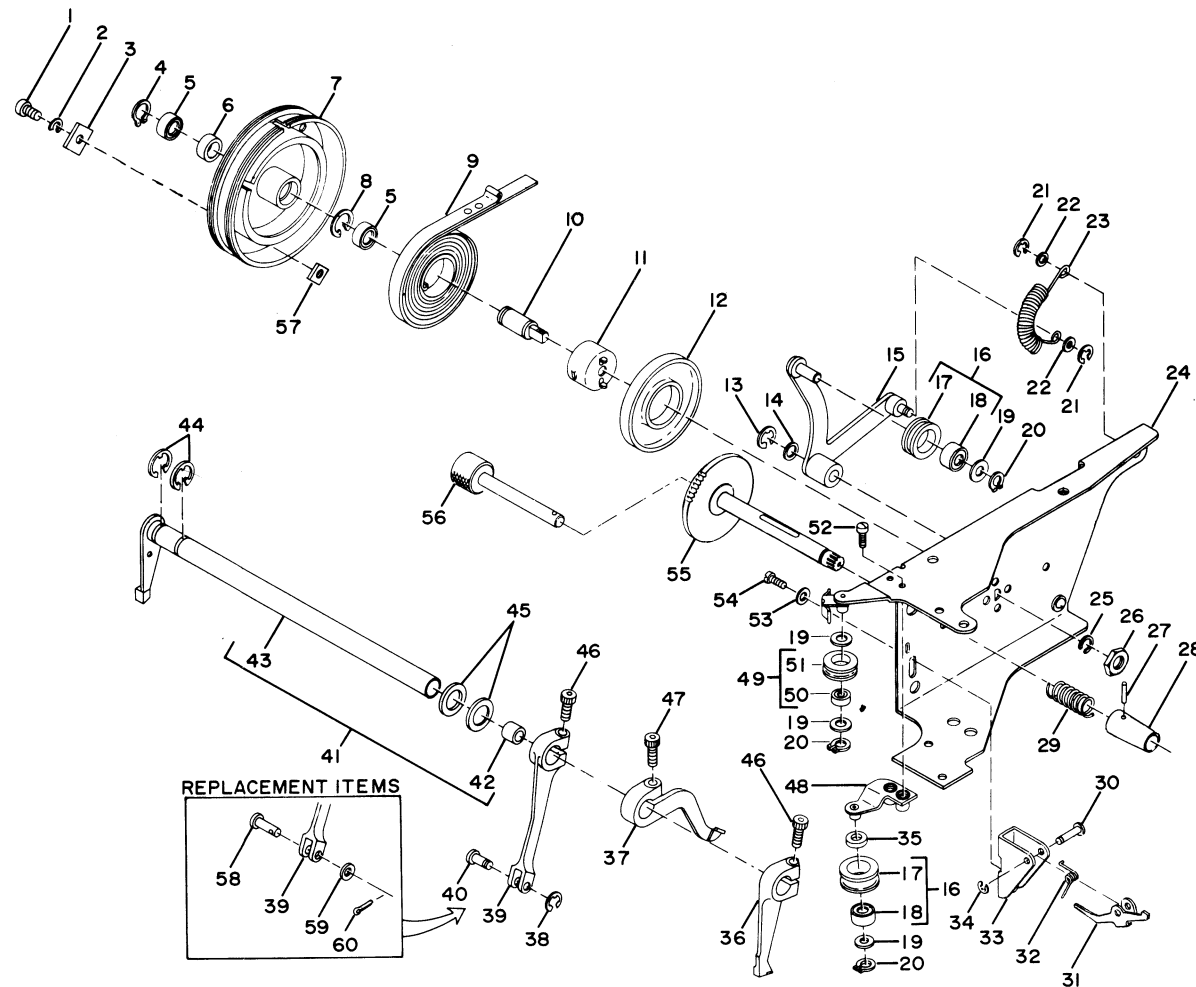

Figure 5-82. Print Hammer, Print Cylinder,  
and Print Cylinder Yoke Assembly  
SL-4-03315B Figure 10



- |    |  |    |   |
|----|--|----|---|
| 1  | Screw, Machine                         | 20 | Pad, Pressure   |
| 2  | Roll, Paper Feed Rubber                | 21 | Spring, Pad   |
| 3  | Sprocket, Paper Feed Tooth             | 22 | Cam Assembly, Pressure Release                        |
| 4  | Guide, Paper Feed                      | 23 | Cam, Pressure Release                                 |
| 5  | Spring, Paper Feed Detent              | 24 | Setscrew, Pressure Release Cam                        |
| 6  | Ring, Retaining                        | 25 | Clamp Assembly, Paper Pressure Release<br>Lever Pivot |
| 7  | Bearing, Ball                          | 26 | Screw   |
| 8  | Washer                                 | 27 | Clamp   |
| 9  | Pin Ratchet Roll                       | 28 | Lever, Paper Pressure Release                         |
| 10 | Ratchet Paper Feed Detent              | 29 | Spring, Paper Release Lever                           |
| 11 | Back Stop Assembly, Paper Feed Detent  | 30 | Ring, Retaining                                       |
| 12 | Ring, Retaining                        | 31 | Nut, Anti-Turn  |
| 13 | Roller, Detent                         | 32 | Arm, Paper Feed Stop                                  |
| 14 | Arm, Paper Feed Detent                 | 33 | Knob, Paper Feed                                      |
| 15 | Shaft, Pressure Roll                   | 34 | Ring, Grip  |
| 16 | Roll, Pressure                         | 35 | Arm, Left-Hand Pressure Roll Actuator                 |
| 17 | Arm, Right-Hand Pressure Roll Actuator | 36 | Shaft, Pressure Roll Pivot                            |
| 18 | Spring, Pressure Roll                  | 37 |   |
| 19 | Shaft, Paper Feed Pressure Release     |    |   |

Figure 5-83. Paper Feed Assembly  
SL-4-03315B Figure 11



1	Screw	21	Ring, Retaining	41	Shaft Assembly Print Lever
2	Washer, Lock	22	Washer, Flat	42	Bearing
3	Clamp, Lateral Control Belt	23	Spring, Lateral Tension Helical	43	Shaft
4	Ring, Retaining	24	Bracket Assembly, Takeup Drum	44	Ring, Retaining
5	Bearing	25	Washer, Lock	45	Washer, Felt
6	Spacer	26	Nut, Plain Hex	46	Screw, Clamping
7	Drum	27	Pin Groove	47	Screw, Clamp
8	Ring	28	Lock, Conical Range Finder Slide	48	Bracket, Left-Hand Belt Pulley
9	Spring, Carriage Return Spiral	29	Spring, Range Finder Lock Helical	49	Pulley Assembly, Cable
10	Shaft, Takeup Drum	30	Shaft	50	Bearing
11	Cup, Carriage Return Spring Mounting	31	Lever	51	Pulley
12	Holder, Carriage Return Spring	32	Spring	52	Screw, Machine
13	Ring	33	Bracket	53	Washer, Flat
14	Washer, Flat	34	Ring, Retaining	54	Screw, Machine
15	Arm, Takeup (Lateral Belt)	35	Spacer	55	Dial, Range
16	Pulley Assembly, Belt	36	Arm, Print Prevent	56	Knob, Range Finder
17	Pulley	37	Follower, Print Cam	57	Nut, Clamp
18	Bearing	38	Ring, Retaining	58	Pin, Clevis
19	Spacer	39	Arm, Print Spring	59	Washer, Nylon
20	Ring	40	Stud, Print Spring Yoke Pivot	60	Cotter Pin

Figure 5-84. Takeup Drum and Linkage Assembly  
SL-4-03315B Figure 12

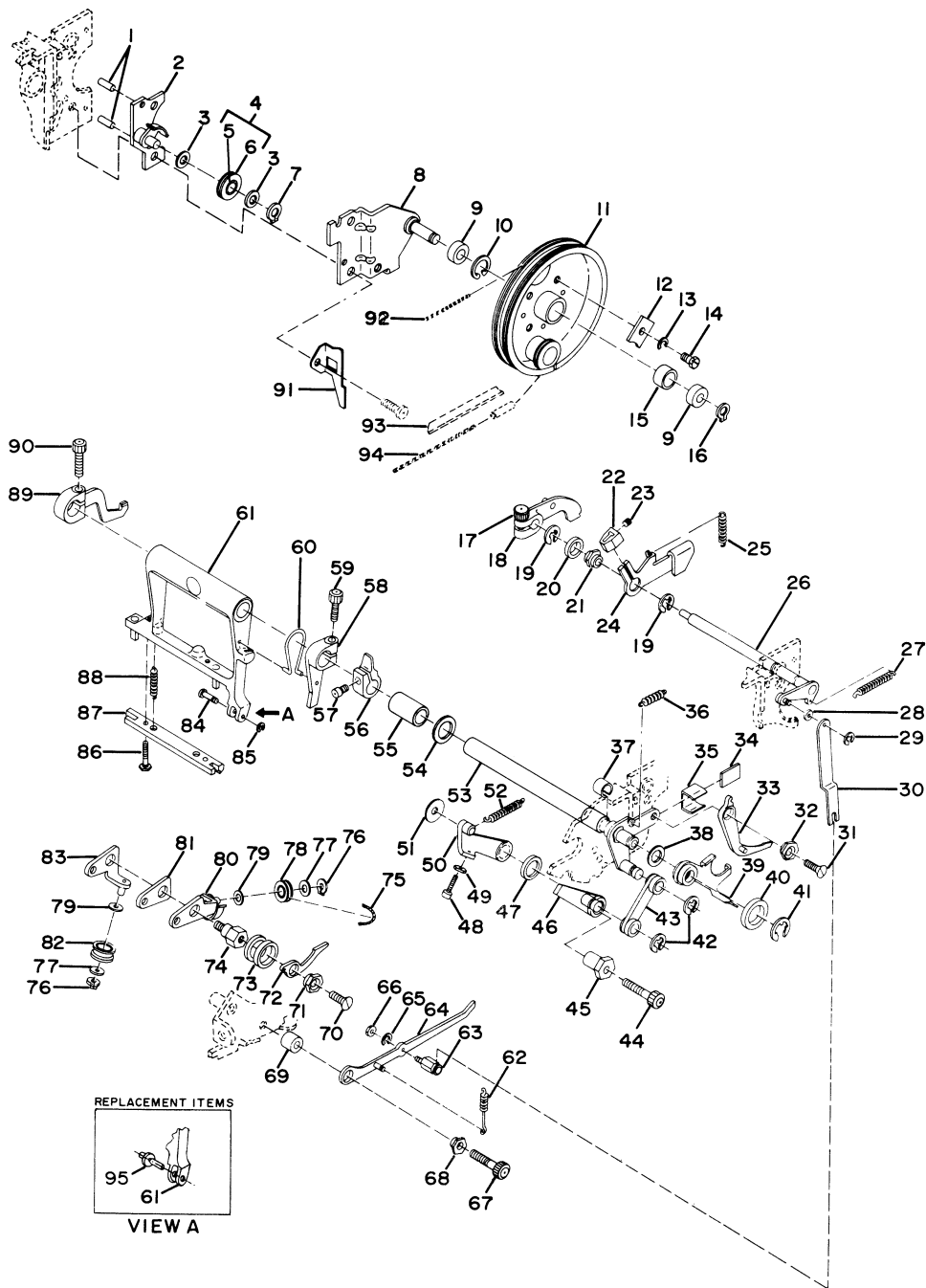

- |    |   |    |  |
|----|---|----|--|
| 1  | Pin, Dowel                                | 50 | Pawl   |
| 2  | Rotary Pulley, Shim and Shaft             | 51 | Washer                                       |
| 3  | Spacer                                    | 52 | Spring, Rotary Detent Pawl                   |
| 4  | Pulley Assembly                           | 53 | Shaft Assembly, Character Advance Lever      |
| 5  | Bearing                                   | 54 | Spacer                                       |
| 6  | Pulley                                    | 55 | Spacer                                       |
| 7  | Ring, Grip                                | 56 | Clamp  |
| 8  | Bracket, Advance Drum                     | 57 | Screw  |
| 9  | Bearing, Ball                             | 58 | Arm, Lifter                                  |
| 10 | Ring, Internal Retaining                  | 59 | Screw, Clamping                              |
| 11 | Drum, Advance                             | 60 | Spring, Lifter Arm                           |
| 12 | Clamp, Cable                              | 61 | Lever Assembly Function                      |
| 13 | Washer, Lock                              | 62 | Spring, Check Pawl                           |
| 14 | Screw, Cable Clamp                        | 63 | Stud, Eccentric                              |
| 15 | Spacer                                    | 64 | Pawl, Check                                  |
| 16 | Ring, Grip                                | 65 | Washer, Lock                                 |
| 17 | Screw, Clamping                           | 66 | Nut, Plain Hex                               |
| 18 | Follower, Carriage Return Cam             | 67 | Screw  |
| 19 | Ring, Retaining                           | 68 | Bushing, Check Pawl Eccentric                |
| 20 | Washer, Felt                              | 69 | Spacer                                       |
| 21 | Bushing, Eccentric                        | 70 | Screw, Machine                               |
| 22 | Clamp                                     | 71 | Bushing, Advance Suppression Latch Eccentric |
| 23 | Setscrew                                  | 72 | Latch, Advance Suppression Latch Eccentric   |
| 24 | Lever, Bounce Prevent                     | 73 | Washers, Felt                                |
| 25 | Spring, Bounce Prevent Lever              | 74 | Stud, Advance Suppression Latch Mounting     |
| 26 | Shaft Assembly, Carriage Return           | 75 | Cable, Rotary                                |
| 27 | Spring, Advance Prevent Lever             | 76 | Ring, Grip                                   |
| 28 | Spacer                                    | 77 | Spacer                                       |
| 29 | Ring, Retaining                           | 78 | Pulley Assembly                              |
| 30 | Link, Check Pawl                          | 79 | Spacer                                       |
| 31 | Screw                                     | 80 | Shaft Assembly                               |
| 32 | Bushing, Character Advance Pawl Eccentric | 81 | Bracket, Spacer                              |
| 33 | Pawl, Character Advance                   | 82 | Pulley                                       |
| 34 | Strip, Felt                               | 83 | Bracket, Lateral Control Belt Pulley         |
| 35 | Clip, Felt Strip                          | 84 | Stud, Function Spring Yoke Pivot             |
| 36 | Spring, Character Advance Pawl            | 85 | Ring   |
| 37 | Strip, Felt                               | 86 | Screw, Special                               |
| 38 | Shim                                      | 87 | Bar, Function                                |
| 39 | Lever, Advance Prevent                    | 88 | Spring, Function Lever Compression           |
| 40 | Washer, Felt                              | 89 | Follower, Function Cam                       |
| 41 | Ring Retaining                            | 90 | Screw, Clamping                              |
| 42 | Ring Retaining                            | 91 | Bracket, Check Pawl Guide                    |
| 43 | Link, Index                               | 92 | Cable, Return                                |
| 44 | Screw                                     | 93 | Belt, Lateral Control                        |
| 45 | Bushing, Rotary Detent Pawl Eccentric     | 94 | Cable, Hammer                                |
| 46 | Arm, Rotary Detent Actuator               | 95 | Pin, Function Spring Yoke Pivot Stud         |
| 47 | Washer, Felt                              | 96 | Pincotter                                    |
| 48 | Screw, Rotary Detent Pawl Adjustment      | 97 | Washer, Nylon                                |
| 49 | Nut, Plain Hex                            | 98 | Pin  |

Figure 5-85. Advance Drum and Linkage Assembly  
SL-4-03315B Figure 13



- 1 Setscrew, Clamp
- 2 Clamp
- 3 Backstop, Function
- 4 Bushing, Function Backstop Eccentric
- 5 Spacer, Sleeve
- 6 Ring, Retaining
- 7 Shaft, Function Backstop
- 8 Ring, Retaining
- 9 Spacers
- 10 Lever, Carriage Return & Line Feed Sensing Finger
- 11 Arm, Line Feed Clutch Release
- 12 Spring, Function Sensing Finger Lever Helical
- 13 Lever, Off Line Line Feed Sensing Finger
- 14 Lever, Function Sensing Finger
- 15 Arm, Figures Clutch Release
- 16 Lever, Bell Actuator Sensing Finger
- 17 Arm, Bell Advance Suppression
- 18 Arm, Letters Clutch Release
- 19 Lever, Off Line Letters Sensing Finger
- 20 Lever, Off Line Carriage Return Sensing Finger

- 21 Arm, Carriage Return Clutch Release
- 22 Spring, Function Clutch Release Arm Return Helical
- 23 Spring, Off Line Letters Sensing Finger Lever
- 24 Rod, Bell Actuator Connecting
- 25 Spring, Function Backstop
- 26 Screw, Function Advance Prevent Adjustment
- 27 Plate, Nylon Locking Bar
- 28 Bar
- 29 Shaft, Advance Prevent Bail Carriage Return Bar
- 30 Arm, Blank Advance Suppression
- 31 Lever, Blank Sensing Finger
- 32 Arm, Space
- 33 Shaft, Function Clutch Release
- 34 Ring, Retaining
- 35 Frame Assembly, Function Clutch Release and Back-Stop
- 36 Shaft, Function Clutch Release Arm Stop
- 37 Ring, Retaining
- 38 Spring, Print Prevent Rod Actuator Arm Bias
- 39 Ring, Retaining
- 40 Arm, Right-Hand Print Prevent Rod Actuator
- 41 Screw, Print Prevent Rod Actuator Arm
- 42 Rod, Assembly
- 43 Washer, Flat
- 44 Screw
- 45 Strip, Lock
- 46 Screw, Print Prevent Adjustment

- 47 Screw
- 48 Shaft Assembly, Print Prevent Rod Lever
- 49 Arm, Left-Hand Print Prevent Rod Actuator
- 50 Nut
- 51 Stud, Rotary Chain Adjustment
- 52 Pin
- 53 Ring, Retaining
- 54 Chain, Rotary
- 55 Spacer
- 56 Pin
- 57 Ring, Retaining
- 58 Spring, Safety
- 59 Strip, Rotary
- 60 Ring, Retaining
- 61 Ring, Retaining
- 62 Pulley Assembly, Rotary Cable
- 63 Pulley
- 64 Bearing
- 65 Pin
- 66 Slide Assembly, Function
- 67 Spacer
- 68 Screw
- 69 Spacer
- 70 Clip
- 71 Washer, Lock
- 72 Screw
- 73 Slide, Rotary Function
- 74 Support
- 75 Slide, Lateral Control Function
- 76 Pulley Assembly, Lateral Control Belt
- 77 Pulley
- 78 Bearing
- 79 Ring, Retaining
- 80 Pin
- 81 Fork
- 82 Spring, Slack Takeup
- 83 Strip, Lateral Control
- 84 Slide, Slack Takeup
- 85 Link
- 86 Lever, Lateral Control Chain Takeup
- 87 Eccentric, Lateral Control Chain Takeup
- 88 Washer, Lock
- 89 Screw
- 90 Pin
- 91 Chain, Lateral Control
- 92 Pin
- 93 Spacer
- 94 Ring, Retaining
- 95 Spacer
- 96 Ring, Retaining
- 97 Link, Detent
- 98 Pin
- 99 Spring, Safety
- 100 Screw
- 101 Plate, Retaining
- 102 Nut, Plain Hex
- 103 Setscrew, Print Prevent Stop Adjustment
- 104 Spring, Off-Line Function Return Helical
- 105 Slide Assembly
- 106 Lever Assembly, Bell
- 107 Bar, Spring
- 108 Strip, Function Sensing Finger Lever Stop
- 109 Spring, Clip

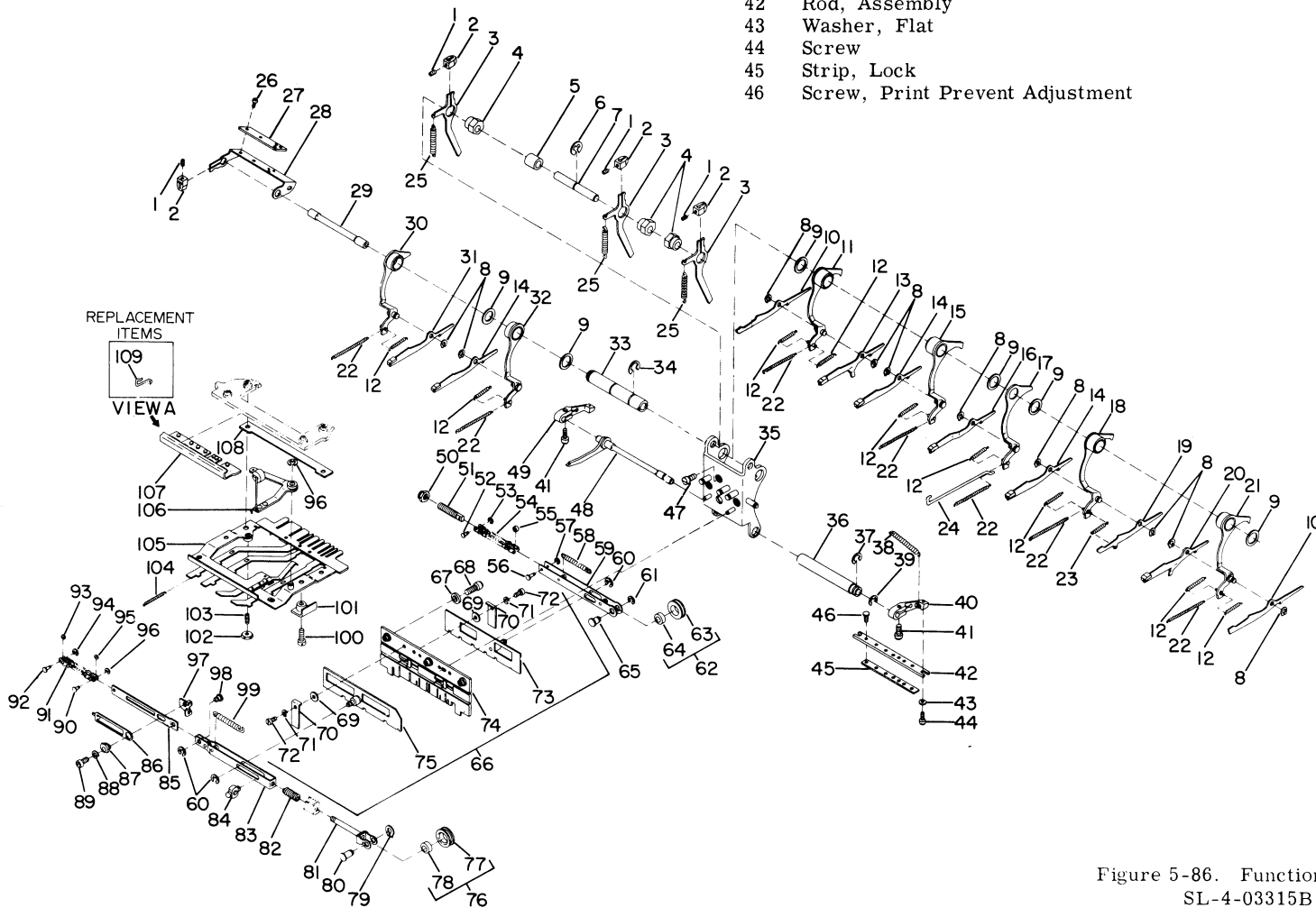

Figure 5-86. Function Selector Assembly  
SL-4-03315B Figure 17

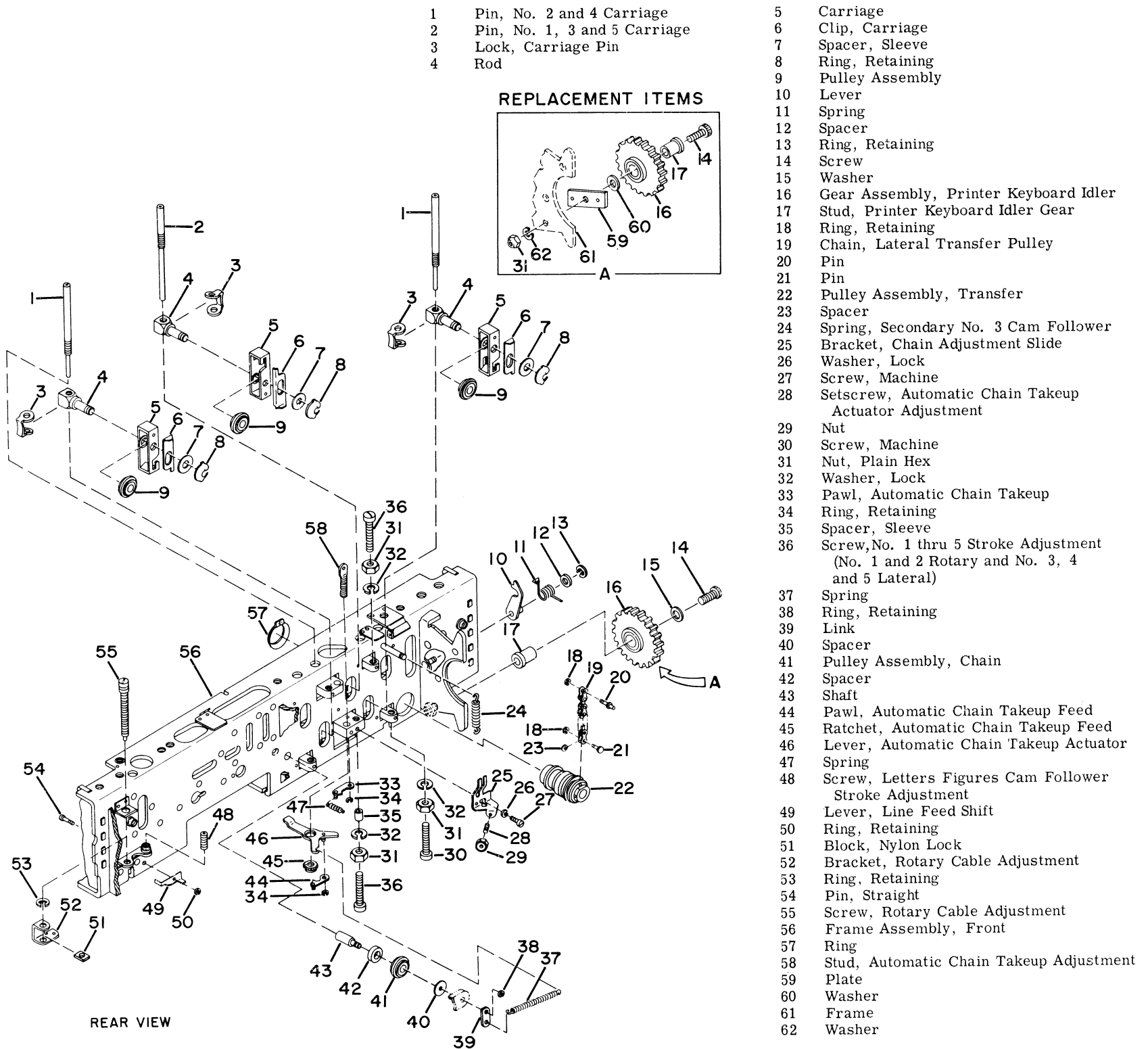

Figure 5-87. Front Frame Assembly (Rear View)  
SL-4-03315B Figure 15A

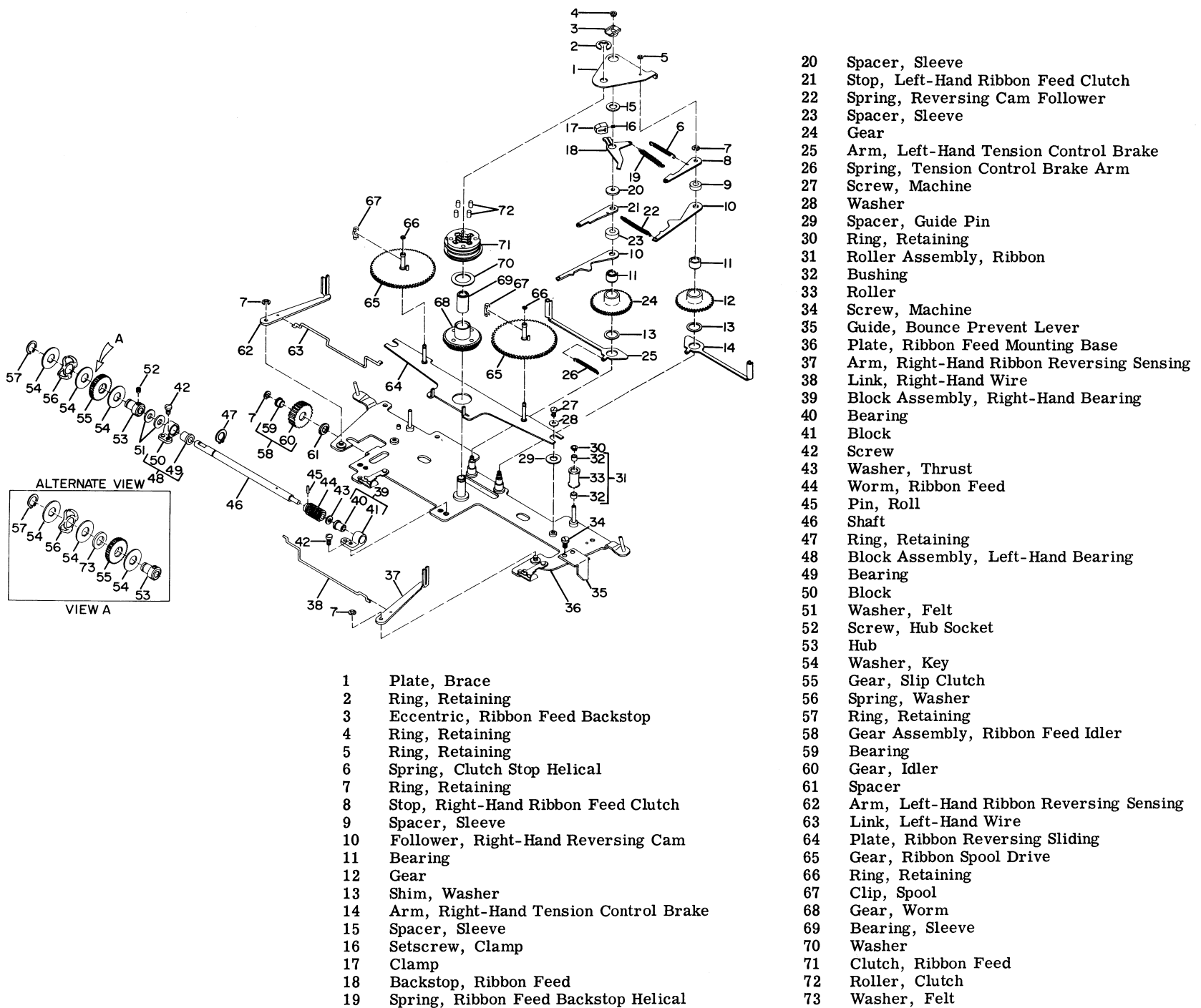
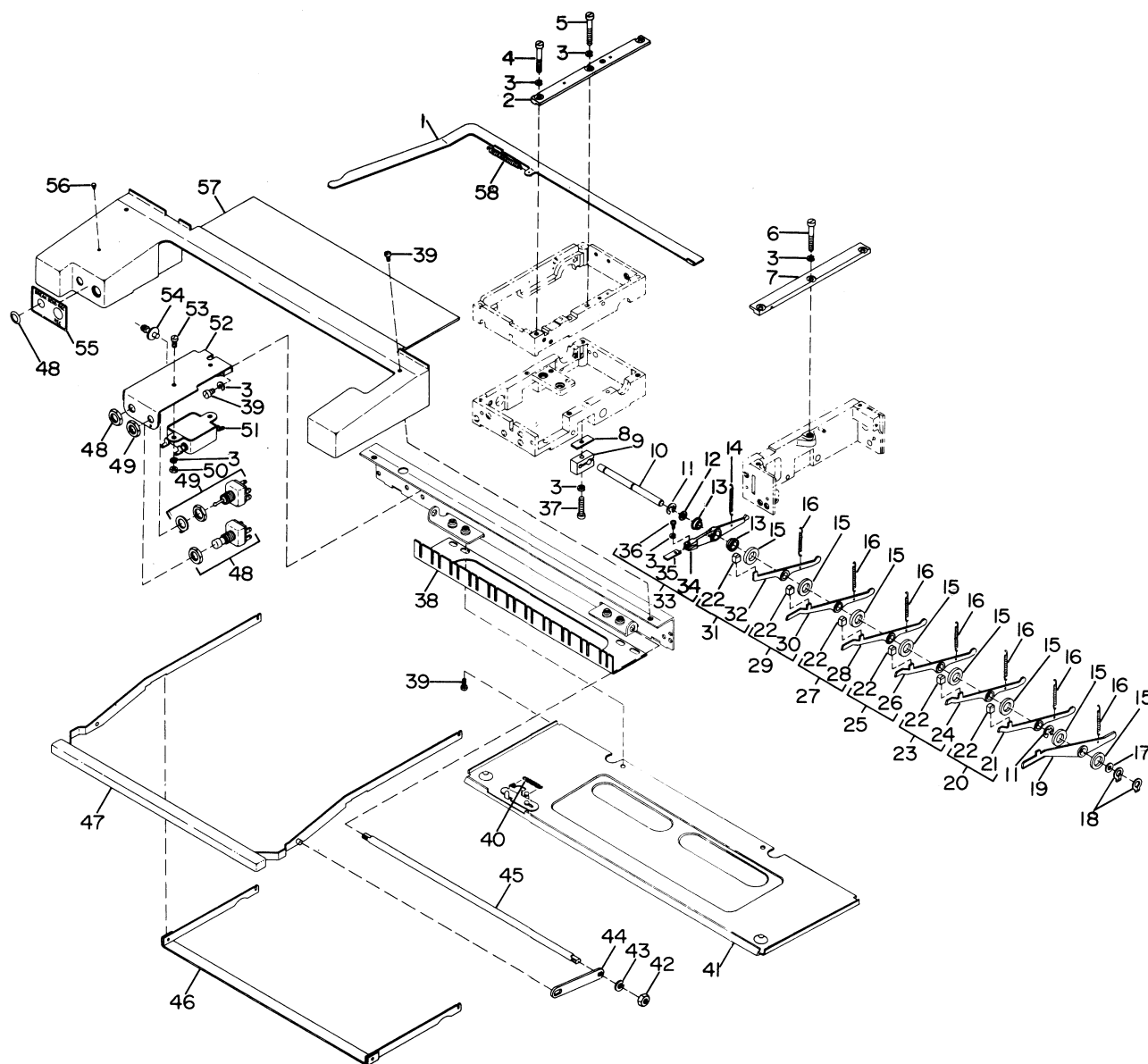

Figure 5-88. Ribbon Feed Top Plate Assembly  
SL-4-03315B Figure 9



- 1 Bar, Keyboard Lock
- 2 Rail, Keyboard Left-Hand
- 3 Washer, Lock
- 4 Screw, Machine
- 5 Screw, Machine
- 6 Screw, Machine
- 7 Rail, Keyboard Right-Hand
- 8 Shim, Pulsing Finger Adjustment
- 9 Clamp, Shaft
- 10 Shaft, Pulsing Finger and Prevent Lever
- 11 Ring, Retaining
- 12 Spacer, Sleeve
- 13 Bearing, Master Pulsing Cam Follower
- 14 Spring, Helical
- 15 Washer, Felt
- 16 Spring, Helical
- 17 Spacer, Sleeve
- 18 Ring, Retaining
- 19 Lever, Keyboard Code Bar Prevent
- 20 Finger Assembly, No. 5 Pulsing
- 21 Finger
- 22 Pusher
- 23 Finger Assembly, No. 4 Pulsing
- 24 Finger
- 25 Finger Assembly, No. 3 Pulsing
- 26 Finger
- 27 Finger Assembly, No. 2 Pulsing
- 28 Finger
- 29 Finger Assembly, No. 1 Pulsing
- 30 Finger
- 31 Finger Assembly, Start Pulsing
- 32 Finger
- 33 Follower Assembly, Master Pulsing Cam
- 34 Follower, Cam
- 35 Actuator, Keyboard Contact
- 36 Screw, Machine
- 37 Screw, Machine
- 38 Guide, Front Key
- 39 Screw, Machine
- 40 Spring
- 41 Cover, Space Bar Safety Guard
- 42 Nut, Plain Hex
- 43 Washer, Lock
- 44 Arm, Space Bar Control
- 45 Shaft, Space Bar
- 46 Pad, Wear
- 47 Bar, Space
- 48 Switch, Break Pushbutton
- 49 Switch, Send-Rec-Rec Toggle
- 50 Nut, Plain Hex
- 51 Filter, Keyboard
- 52 Bracket, Switch
- 53 Screw, Machine
- 54 Terminals
- 55 Plate Designation
- 56 Pad, Keyboard Cover
- 57 Cover, Keyboard
- 58 Spring, Keyboard Lock Bar Helical

Figure 5-89. Keyboard Assembly (Sheet 1 of 3)  
SL-4-03315B Figure 6

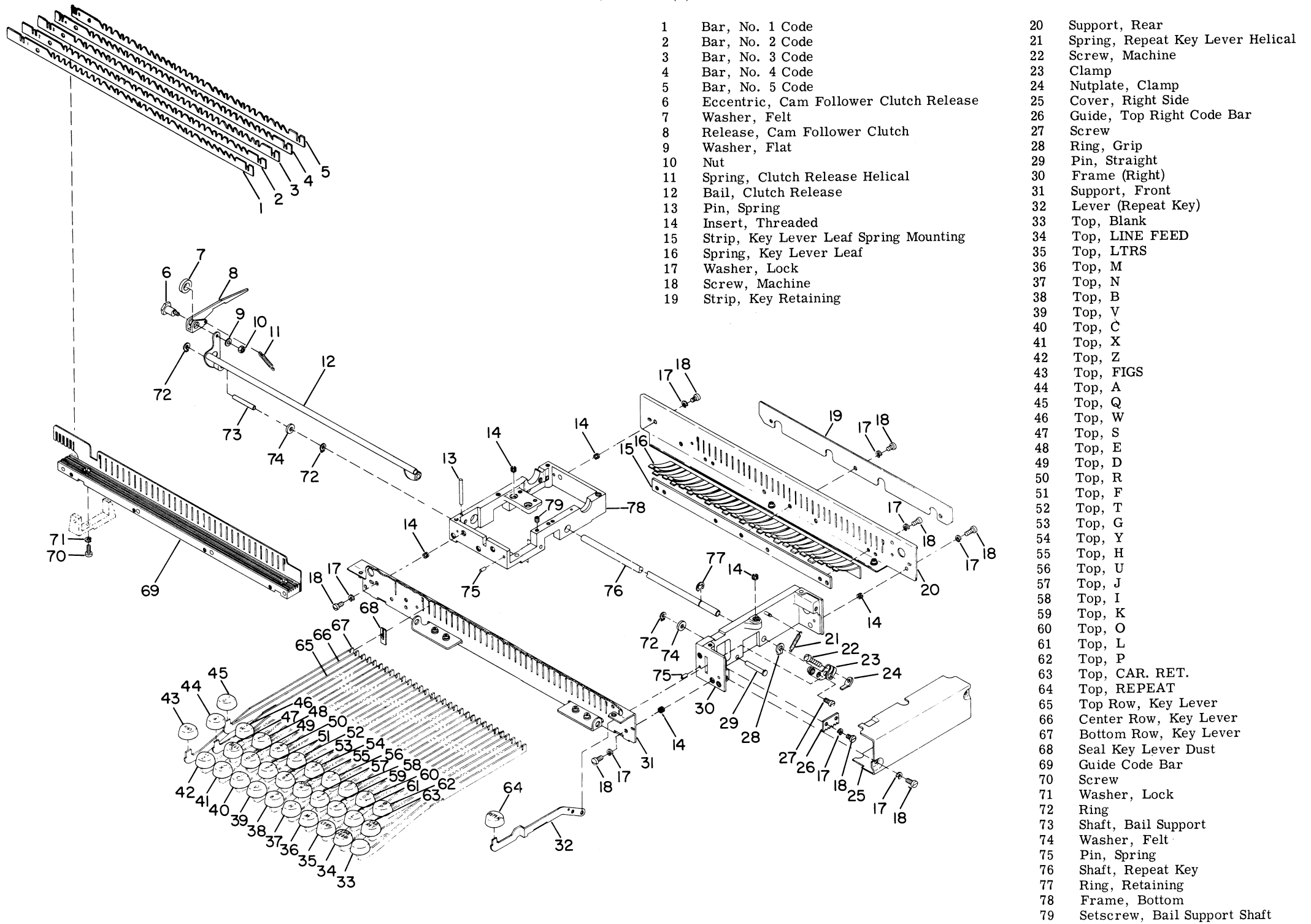

Figure 5-89. Keyboard Assembly (Sheet 2 of 3)  
SL-4-03315B Figure 6A

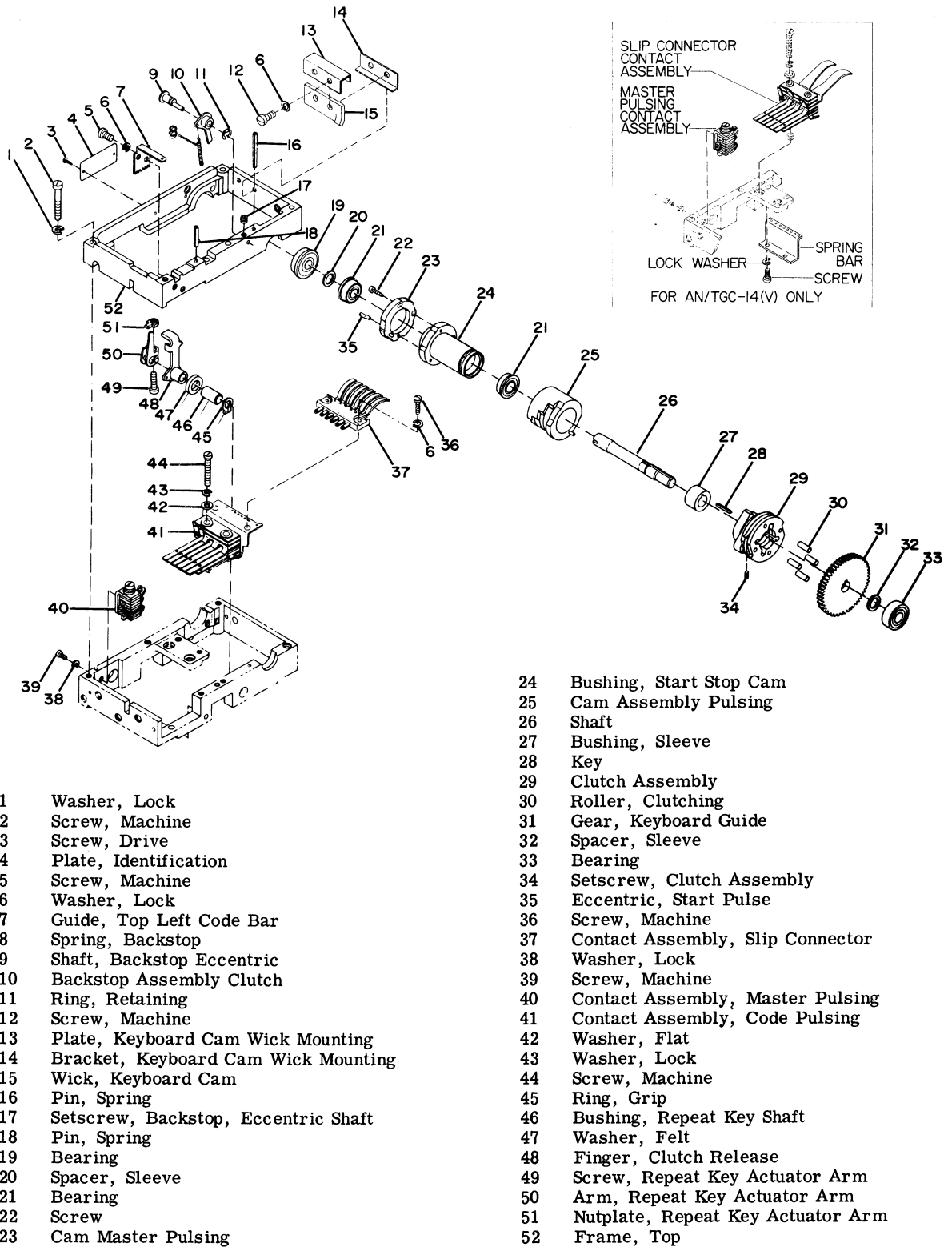
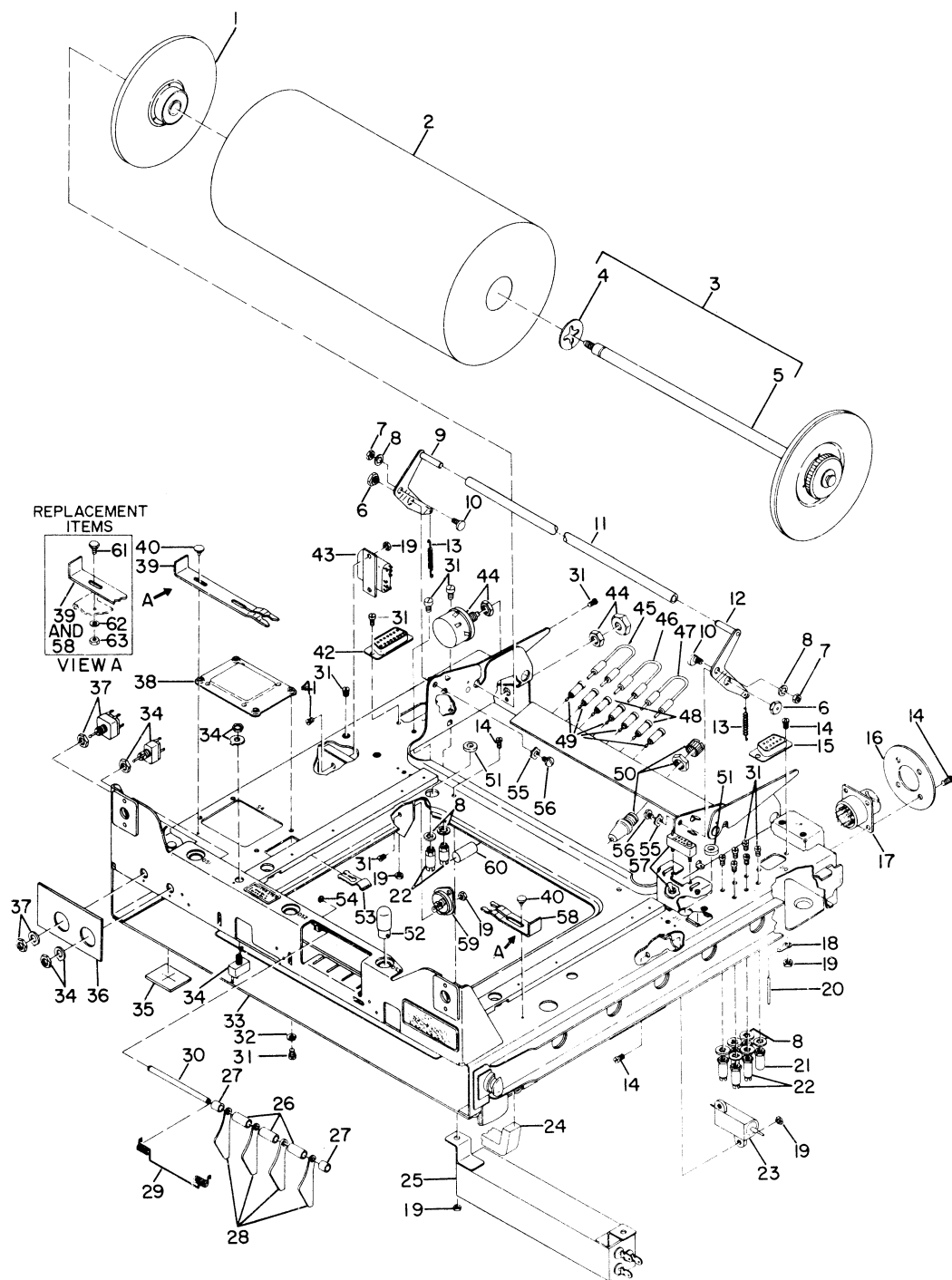
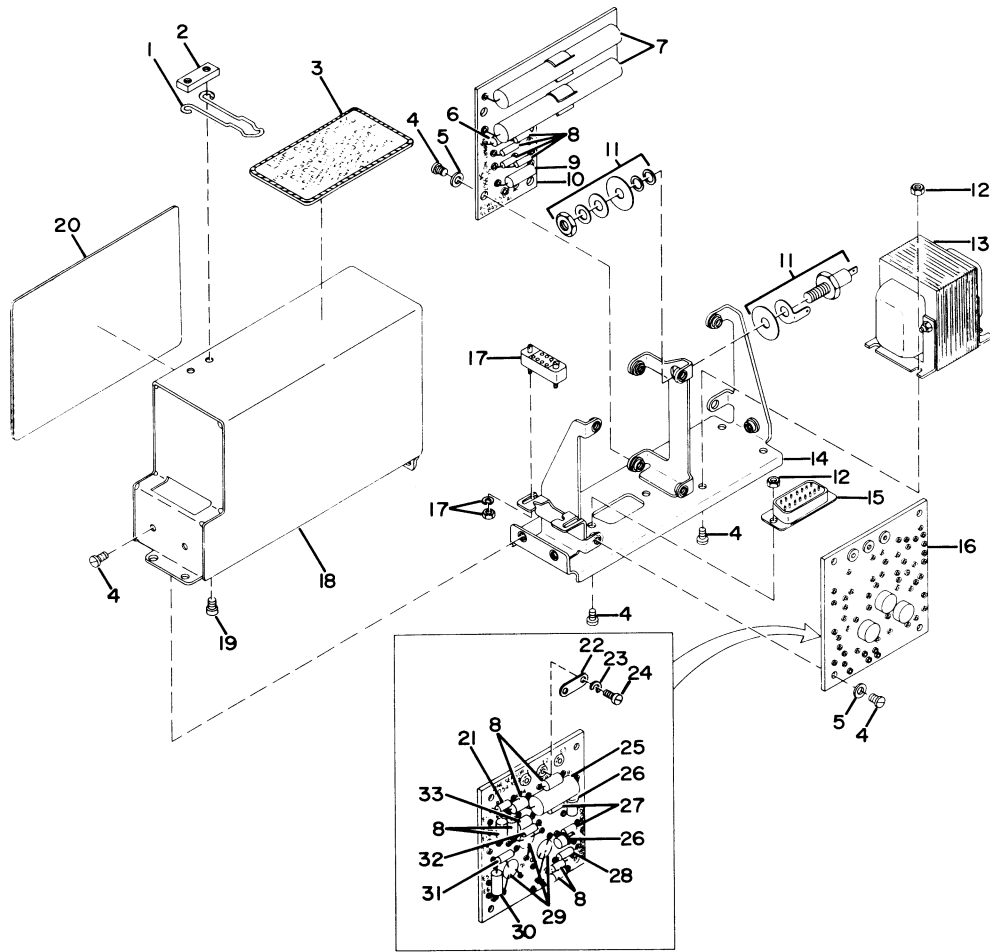

Figure 5-89. Keyboard Assembly (Sheet 3 of 3)  
SL-4-03315B Figure 6B



- 1 Drum, Brake
- 2 Roll, Paper Supply
- 3 Shaft and Disc Assembly, Paper Support
- 4 Disc, Guide
- 5 Drum Assembly
- 6 Pivot, Paper Brake Link
- 7 Nut
- 8 Washer, Lock
- 9 Link, Left-Hand Paper Brake
- 10 Eccentric, Paper Brake Link
- 11 Tube, Dancer Roll (Paper Brake Release)
- 12 Link, Right-Hand Paper Brake
- 13 Spring, Paper Brake Link
- 14 Screw
- 15 Receptacle, Signal Line Power Supply
- 16 Plate, Seal
- 17 Receptacle, Service Cable
- 18 Terminal, Solder
- 19 Nut
- 20 Shaft
- 21 Terminal, Heating Element
- 22 Terminal
- 23 Resistor, D-c Motor
- 24 Seal, Dust
- 25 Capacitor, Motor Starting
- 26 Spacer
- 27 Spacer
- 28 Lever, Off-Line Function
- 29 Spring
- 30 Shaft
- 31 Screw
- 32 Washer, Lock
- 33 Chassis
- 34 Switch Copy Light
- 35 Seal, Dust
- 36 Seal, Dust
- 37 Switch, Motor Main Power
- 38 Block, Contact
- 39 Printer Slide Lock
- 40 Rivet, Stud
- 41 Screw
- 42 Receptacle, Line Sensor
- 43 Relay, Motor Stop
- 44 Resistor, Line Adjustment
- 45 Cord Assembly, White Patch
- 46 Cord Assembly, Blue Patch
- 47 Cord Assembly, Red Patch
- 48 Receptacle, Red Patching
- 49 Receptacle, White Patching
- 50 Fuseholder
- 51 Grommet
- 52 Lamp
- 53 Clamp, Harness
- 54 Ring
- 55 Washer, Lock
- 56 Screw
- 57 Receptacle, Motor
- 58 Printer Slide Lock
- 59 Thermostat
- 60 Resistor, External Line Sensor
- 61 Screw, Stud
- 62 Washer, Lock
- 63 Nut, Plain Hex

Figure 5-90. Electrical Chassis Assembly  
SL-4-03315B Figure 24



- |    |                        |    |                       |
|----|------------------------|----|-----------------------|
| 1  | Clip, Selector Cable   | 17 | Receptacle, Selector  |
| 2  | Clip, Holder           | 18 | Cover                 |
| 3  | Nameplate              | 19 | Screw                 |
| 4  | Screw                  | 20 | Nameplate             |
| 5  | Washer, Flat           | 21 | Resistor              |
| 6  | Resistor               | 22 | Strip, High-Low Range |
| 7  | Capacitor              | 23 | Washer, Lock          |
| 8  | Rectifier              | 24 | Screw                 |
| 9  | Resistor               | 25 | Resistor              |
| 10 | Board                  | 26 | Diode                 |
| 11 | Diode                  | 27 | Resistor              |
| 12 | Nut                    | 28 | Resistor              |
| 13 | Transformer            | 29 | Transistor            |
| 14 | Bracket                | 30 | Resistor              |
| 15 | Connector, Line Sensor | 31 | Resistor              |
| 16 | Board                  | 32 | Resistor              |
|    |                        | 33 | Resistor              |

Figure 5-91. Line Sensor  
SL-4-03315B Figure 26



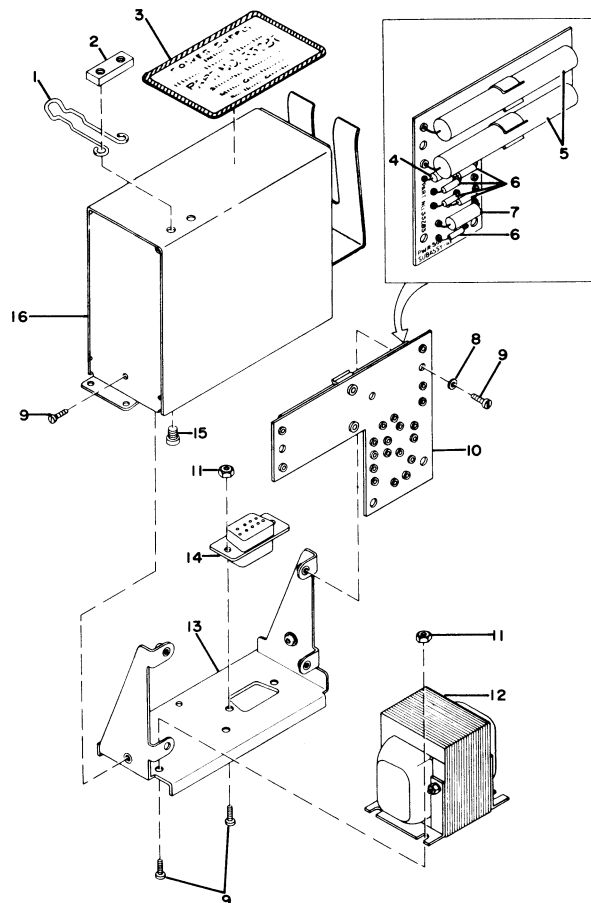

- |   |                   |    |                              |
|---|-------------------|----|------------------------------|
| 1 | Clip, Motor Cable | 9  | Screw                        |
| 2 | Clip, Holder      | 10 | Board                        |
| 3 | Nameplate         | 11 | Nut                          |
| 4 | Resistor          | 12 | Transformer                  |
| 5 | Capacitor         | 13 | Bracket                      |
| 6 | Rectifier         | 14 | Connector, Signal Line Power |
| 7 | Resistor          | 15 | Screw                        |
| 8 | Washer            | 16 | Cover                        |

Figure 5-92. Signal Line Power Supply  
SL-4-03315B Figure 27

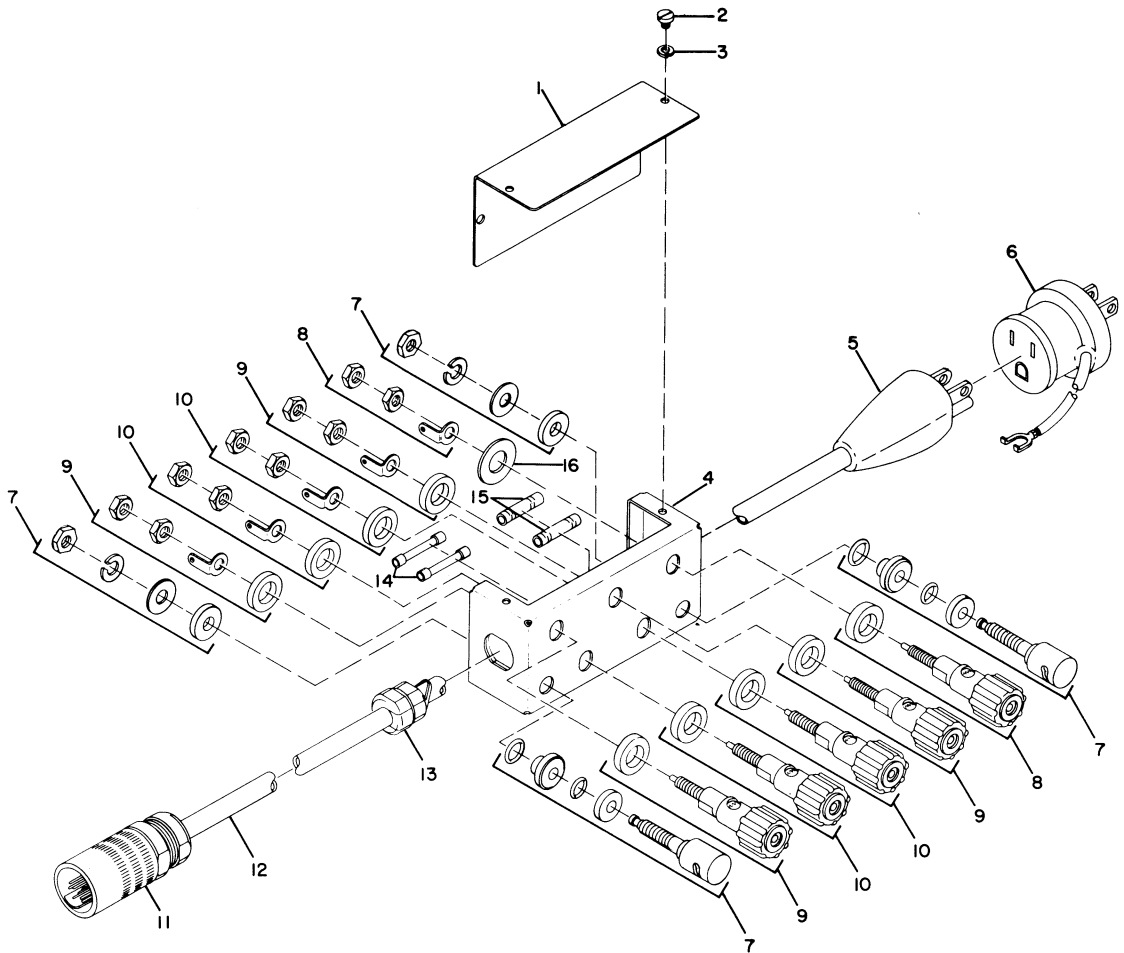

- |   |                |    |                               |
|---|----------------|----|-------------------------------|
| 1 | Cover          | 9  | Post, Binding                 |
| 2 | Screw, Machine | 10 | Post, Binding                 |
| 3 | Washer, Lock   | 11 | Connector-Plug, Service Cable |
| 4 | Junction Box   | 12 | Cable, Electric               |
| 5 | Cord           | 13 | Bushing, Sleeve               |
| 6 | Adapter        | 14 | Capacitors (C1, C2)           |
| 7 | Post, Binding  | 15 | Splice                        |
| 8 | Post, Binding  | 16 | Washer, Flat                  |

Figure 5-93. Service Cable  
SL-4-03315B Figure 28

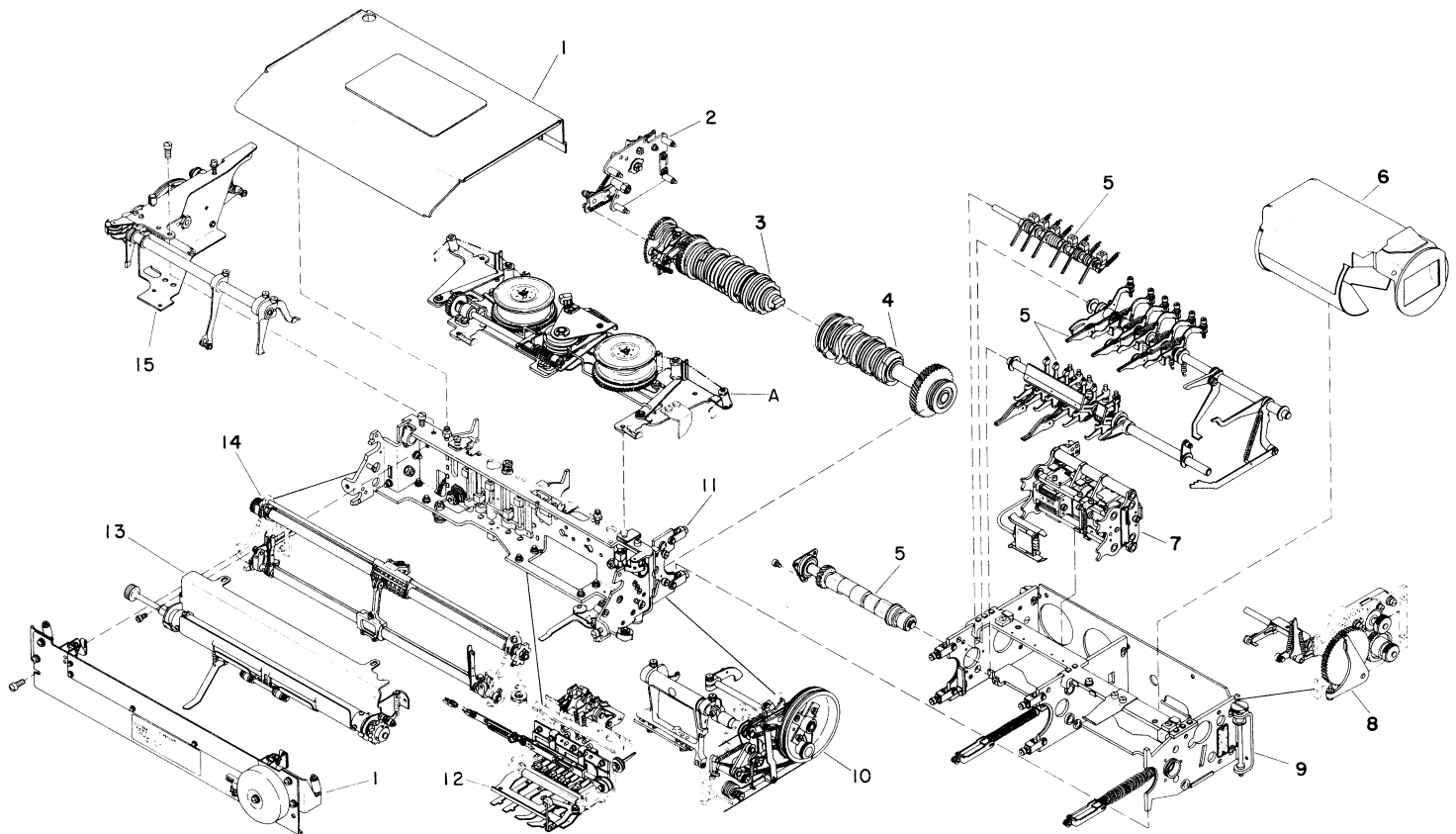

- |   |  |    |  |
|---|--|----|--|
| 1 | Assemblies, Ribbon Feed, Front Plate and Paper Guide (See figure 5-81, Appendix, for breakdown)                                | 8  | Feed Assembly, Gear Train and Automatic Carriage Return Line (See figure 5-77, Appendix, for breakdown)          |
| 2 | Time Delay Assembly, Automatic Motor Stop (See figure 5-69, Appendix, for breakdown)   | 9  | Frame Assembly, Rear (See figure 5-79, Appendix, for breakdown)  |
| 3 | Shaft Assembly, Selector Main (See figure 5-70, Appendix, for breakdown)   | 10 | Linkage Assembly, Advance Drum (See figure 5-85, Appendix, for breakdown)  |
| 4 | Shaft Assembly, Function Main (See figure 5-71, Appendix, for breakdown)   | 11 | Frame Assembly, Front (See figures 5-80 and 5-87, Appendix, for breakdown)                                       |
| 5 | Shaft Assembly, Mark and Space Clutch Release Shaft, Timing Cam Shaft, and Backstop (See figure 5-69, Appendix, for breakdown) | 12 | Selector Assembly, Function (See figure 5-86, Appendix, for breakdown)   |
| 6 | Duct Assembly, Fan Outlet (See figure 5-72, Appendix, for breakdown)   | 13 | Feed Assembly, Paper (See figure 5-83, Appendix, for breakdown)  |
| 7 | Selector Assembly (See figures 5-75 or 5-76, Appendix, for breakdown)  | 14 | Shaft Assembly, Print Hammer, Print Cylinder, and Print Cylinder Yoke (See figure 5-82, Appendix, for breakdown) |
|   |  | 15 | Assemblies, Takeup Drum, Bracket, and Print Shaft (See figure 5-84, Appendix, for breakdown)                     |

Figure 5-94. Printer Assembly  
SL-4-03315B Figure 7

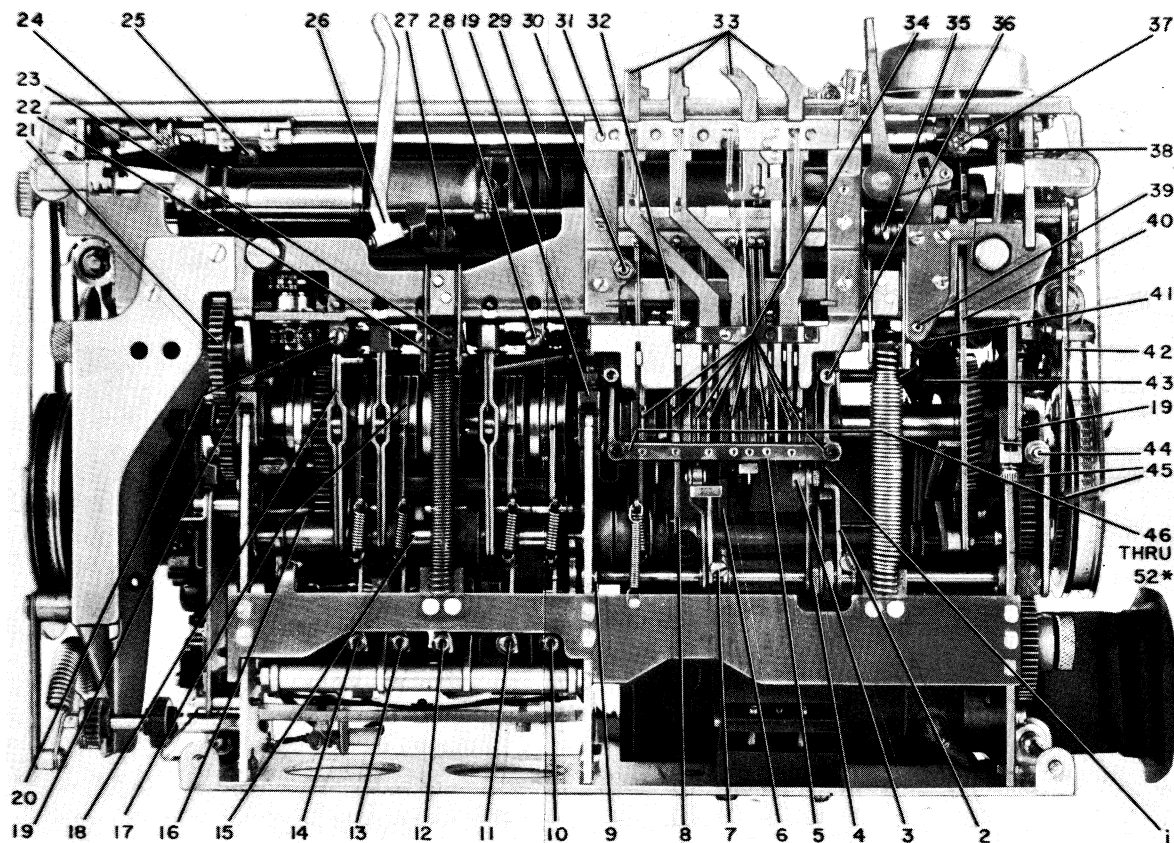

- |    |   |    |   |
|----|---|----|---|
| 1  | Carriage Return Cam (table 5-6, step 8, Appendix)   | 14 | No. 3 Space Clutch Release Finger Adjustment Screw                      |
| 2  | Lock Lever Actuator Arm   | 15 | Space Selector Shaft  |
| 3  | Automatic Carriage Return and Line Feed Bail Actuator Eccentric (table 5-7, step 2, Appendix) | 16 | Timing Cam Shaft  |
| 4  | Carriage Return Lock Lever Eccentric Bushing (table 5-7, step 1, Appendix)                    | 17 | No. 4 Clutch Cage   |
| 5  | Print Prevent Rod (table 5-6, step 9, Appendix)   | 18 | Secondary No. 3 Cam Follower  |
| 6  | Letters Figures Cam Follower (table 5-6, step 8, Appendix)                                    | 19 | Frame Clamps  |
| 7  | Automatic Carriage Return and Line Feed Actuator Arm Screw                                    | 20 | No. 3 Lateral Stroke Adjustment Screw                                   |
| 8  | Line Feed Cam Follower (table 5-6, step 8, Appendix)  | 21 | Keyboard Drive Gear   |
| 9  | V Lever Shaft Bushing (table 5-7, step 1, Appendix)   | 22 | No. 5 Lateral Stroke Adjustment Screw                                   |
| 10 | No. 1 Space Clutch Release Finger Adjustment Screw  | 23 | Automatic Chain Takeup Ratchet  |
| 11 | No. 2 Space Clutch Release Finger Adjustment Screw  | 24 | Left-Hand Vibrator Arm Lock Nut   |
| 12 | No. 5 Space Clutch Release Finger Adjustment Screw  | 25 | Print Hammer Cable Clamp Screw  |
| 13 | No. 4 Space Clutch Release Finger Adjustment Screw  | 26 | Paper Pressure Release Lever (table 5-6, step 6, Appendix)              |
|    |   | 27 | Print Spring Yoke Pivot Stud and Link (table 5-5, step 14, Appendix)    |
|    |   | 28 | No. 1 Rotary Stroke Adjustment Screw                                    |
|    |   | 29 | Pressure Roll   |
|    |   | 30 | Print Prevent Stop Adjustment Setscrew                                  |
|    |   | 31 | Off Line Function Slide (table 5-6, step 9, Appendix)                   |
|    |   | 32 | Function Sensing Finger Lever Stop Strip                                |
|    |   | 33 | Off Line Function Slide Levers (table 5-6, step 9, Appendix)            |
|    |   | 34 | Function Sensing Finger Levers (table 5-6, step 8, Appendix)            |
|    |   | 35 | Function Spring Yoke Pivot Stud and Link (table 5-5, step 14, Appendix) |
|    |   | 36 | Print Prevent Rod Actuator Arm Screw                                    |
|    |   | 37 | Right-Hand Vibrator Arm Lock Nut  |
|    |   | 38 | Paper Feed Detent and Ratchet (table 5-6, step 6, Appendix)             |
|    |   | 39 | Shift Lever Adjustment Screw  |
|    |   | 40 | Line Feed Pawl (table 5-6, step 6, Appendix)                            |
|    |   | 41 | Letters Figures Cam Follower Stroke Adjustment Screw                    |
|    |   | 42 | Check Pawl  |
|    |   | 43 | Letter Figures Arm Adjustment Screw                                     |
|    |   | 44 | First Character Adjustment Screw (table 5-7, step 1, Appendix)          |
|    |   | 45 | Advance Ratchet (table 5-6, step 7, Appendix)                           |
|    |   | 46 | Blank Print Prevent Adjustment Screw                                    |
|    |   | 47 | Space Print Prevent Adjustment Screw                                    |
|    |   | 48 | Line Feed Print Prevent Adjustment Screw                                |
|    |   | 49 | Figures Print Prevent Adjustment Screw                                  |
|    |   | 50 | Bell Print Prevent Adjustment Screw                                     |
|    |   | 51 | Letters Print Prevent Adjustment Screw                                  |
|    |   | 52 | Carriage Return Print Prevent Adjustment Screw                          |

For location of items 46 through 52 on print prevent rod read from left to right.

Figure 5-95. Printer Assembly, Bottom View

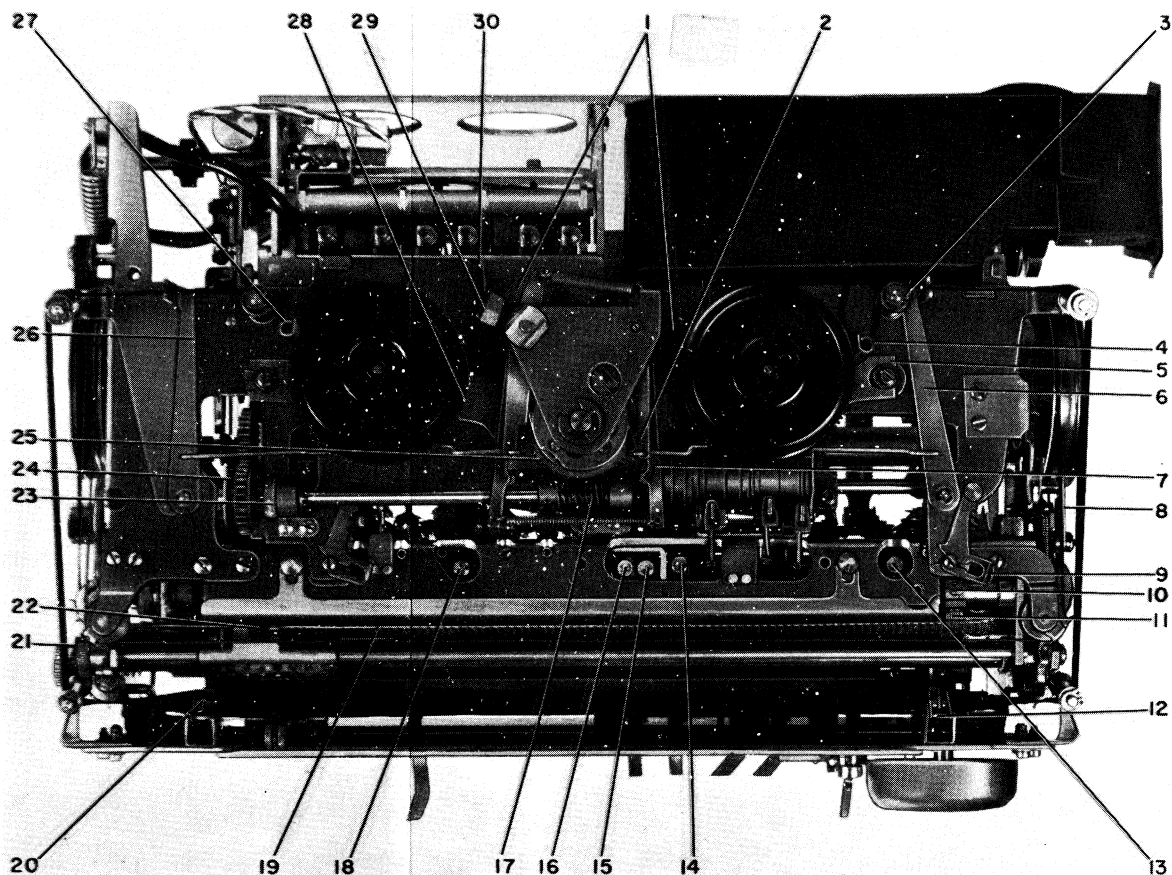

- |    |   |     |  |
|----|---|-----|--|
| 1  | Intermediate Drive Gears (table 5-6, step 1, Appendix)                | •17 | Ribbon Feed Worm (table 5-5, step 2, Appendix)                       |
| 2  | Ribbon Feed Clutch Stop   | 18  | Print Spring Arm Clamping Screw                                      |
| 3  | Ribbon Roller   | 19  | Lateral Control Belt (table 5-5, step 3, Appendix)                   |
| 4  | Right-Hand Tension Control Brake Arm                                  | 20  | Left-Hand Ribbon Vibrator Guide (table 5-5, step 1, Appendix)        |
| 5  | Ribbon Reversing Sliding Plate  | 21  | Rotary Motion Spring Retainer (table 5-6, step 2, Appendix)          |
| 6  | Right-Hand Ribbon Reversing Sensing Arm (table 5-6, step 1, Appendix) | 22  | Print Cylinder Yoke Clamp  |
| 7  | Reversing Cam Follower  | 23  | Felt Washer (table 5-5, step 5, Appendix)                            |
| 8  | Return Cable (table 5-5, step 3, Appendix)                            | 24  | Ribbon Feed Slip Clutch Gear (table 5-5, step 2, Appendix)           |
| 9  | Lock Clips  | 25  | Clutch Shaft Worm Gear   |
| 10 | Code Bar Actuator Clamp (table 5-5, step 4, Appendix)                 | 26  | Left-Hand Ribbon Reversing Sensing Arm (table 5-6, step 1, Appendix) |
| 11 | Code Bar Actuator Clamp Screw   | 27  | Left-Hand Tension Control Brake Arm                                  |
| 12 | Right-Hand Ribbon Vibrator Guide (table 5-5, step 1, Appendix)        | 28  | Ribbon Spool Drive Gear  |
| 13 | Lifter Arm Clamping Screw   | 29  | Ribbon Feed Backstop   |
| 14 | Function Cam Follower Clamping Screw                                  | 30  | Ribbon Feed Top Plate Assembly                                       |
| 15 | Print Prevent Arm Clamping Screw                                      |     |  |
| 16 | Print Cam Follower Clamping Screw                                     |     |  |

Figure 5-96. Printer Assembly, Top View

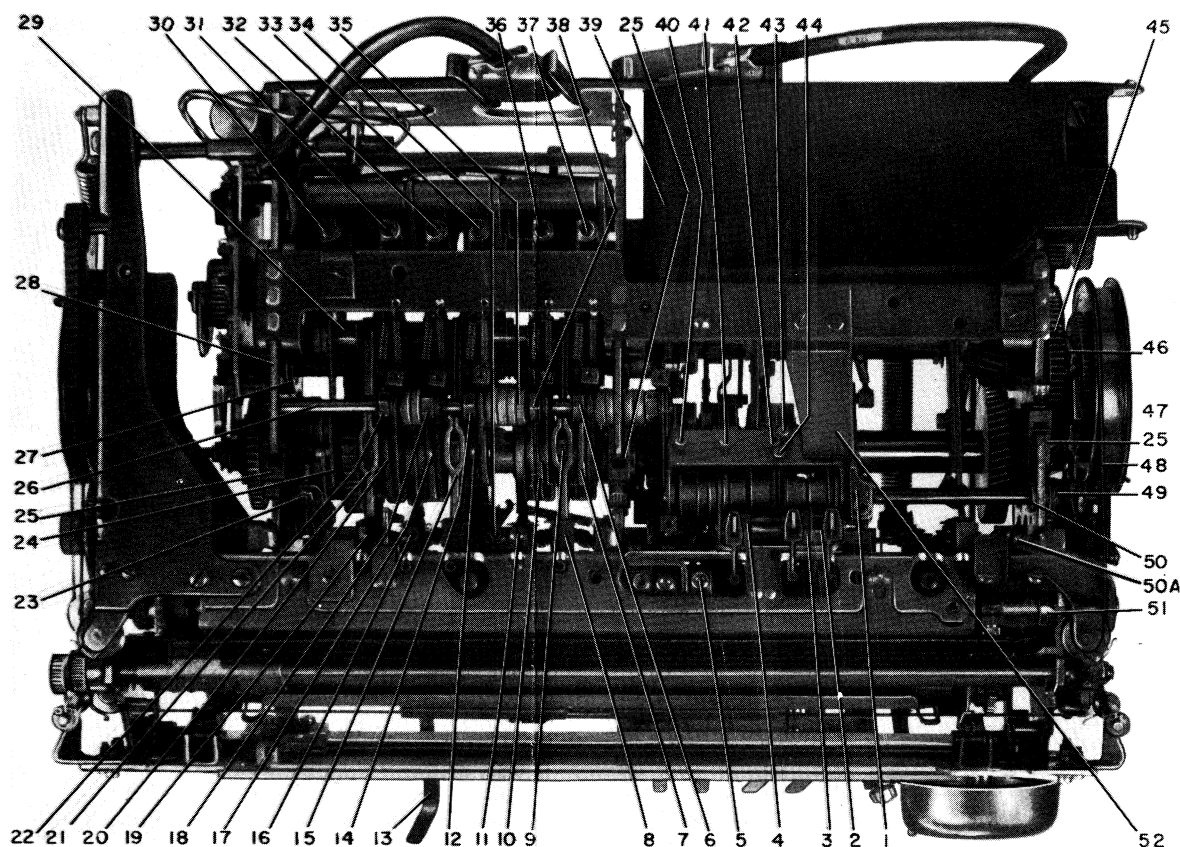

- |     |  |             |  |
|-----|--|-------------|--|
| 1   | Carriage Return Cam Follower (table 5-6, step 5, Appendix)                 |             |  |
| 2   | Carriage Return Backstop Eccentric Bushing                                 |             |  |
| 3   | Letters Figures Backstop Eccentric Bushing                                 |             |  |
| 4   | Line Feed Backstop Eccentric Bushing                                       |             |  |
| 5   | Function Cam Follower Screw  |             |  |
| 6   | No. 1 Clutch Backstop Eccentric Bushing                                    |             |  |
| 7   | No. 1 Mark Clutch Release Finger (table 5-7, step 2, Appendix, typical)    |             |  |
| 8   | No. 1 Carriage Pulley (table 5-7, step 4, Appendix, typical)               |             |  |
| 9   | No. 1 Type Positioning Cam Follower (table 5-7, step 4, Appendix, typical) |             |  |
| 10  | No. 2 Mark Clutch Release Finger   |             |  |
| 11  | No. 2 Rotary Stroke Adjustment Screw                                       |             |  |
| 12  | No. 5 Mark Clutch Release Finger   |             |  |
| 13  | Paper Pressure Release Lever   |             |  |
| 14  | No. 5 Clutch Backstop Eccentric Bushing                                    |             |  |
| 15  | No. 5 Type Positioning Cam Follower  |             |  |
| 16  | No. 4 Lateral Stroke Adjustment Screw                                      |             |  |
| 17  | No. 4 Mark Clutch Release Finger   |             |  |
| 18  | No. 4 Clutch Backstop Eccentric Bushing                                    |             |  |
| 19  | No. 3 Carriage Pulley  |             |  |
| 20  | No. 3 Mark Clutch Release Finger   |             |  |
| 21  | No. 3 Type Positioning Cam Follower  |             |  |
| 22  | No. 3 Clutch Backstop Eccentric Bushing                                    |             |  |
| 23  | Start Clutch Backstop  |             |  |
| 24  | Start Clutch Release Latch Pin   |             |  |
| 25  | Frame Clamps   |             |  |
| 26  | Backstop Shaft   |             |  |
| 27  | Timing Cam Shaft   |             |  |
| 28  | Start Clutch Release Arm   |             |  |
| 29  | Mark Selector Shaft  |             |  |
| 30  | Start Clutch Release Arm Adjustment Screw                                  |             |  |
| 31  | No. 3 Clutch Release Finger Adjustment Screw                               | } Mark Side |  |
| 32  | No. 4 Clutch Release Finger Adjustment Screw                               |             |  |
| 33  | No. 5 Clutch Release Finger Adjustment Screw                               |             |  |
| 34  | Rotary Chain Adjustment Stud   |             |  |
| 35  | Felt Washer  |             |  |
| 36  | No. 2 Clutch Release Finger Adjustment Screw                               | } Mark Side |  |
| 37  | No. 1 Clutch Release Finger Adjustment Screw                               |             |  |
| 38  | No. 2 Clutch Backstop Eccentric Bushing                                    |             |  |
| 39  | Fan Outlet Duct Assembly   |             |  |
| 40  | Blank Advance Prevent Adjustment Screw                                     |             |  |
| 41  | Line Feed Advance Prevent Adjustment Screw                                 |             |  |
| 42  | Figures Advance Prevent Adjustment Screw                                   |             |  |
| 43  | Letters Advance Prevent Adjustment Screw                                   |             |  |
| 44  | Bell Advance Prevent Adjustment Screw                                      |             |  |
| 45  | Second Reduction Gear (table 5-5, step 13, Appendix)                       |             |  |
| 46  | V Lever Tab (table 5-7, step 1, Appendix)                                  |             |  |
| 47  | Third Reduction Gear (table 5-5, step 13, Appendix)                        |             |  |
| 48  | Bounce Prevent Lever   |             |  |
| 49  | Bounce Prevent Lever Eccentric Bushing                                     |             |  |
| 50  | Carriage Return Shaft Bushing  |             |  |
| 50a | Rotary Cable Adj. Screw  |             |  |
| 51  | Character Advance Lever Shaft Bushing                                      |             |  |
| 52  | Advance Prevent Stop Spring  |             |  |

Figure 5-97. Printer Assembly, Top View (Ribbon Feed Top Plate Assembly Removed)

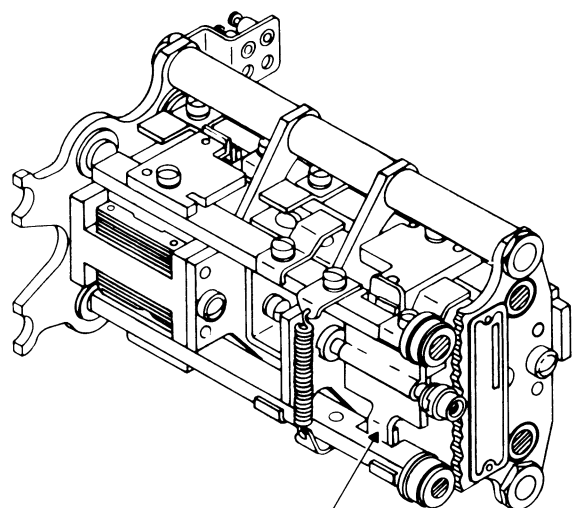

PUSH IN AT THIS POINT TO RELEASE START CLUTCH. (ACCESS FROM BOTTOM OF PRINTER)

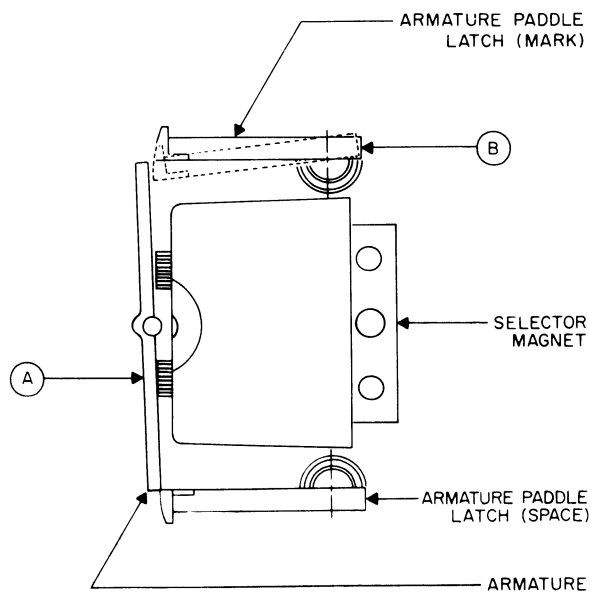

Figure 5-98. Selector Assembly

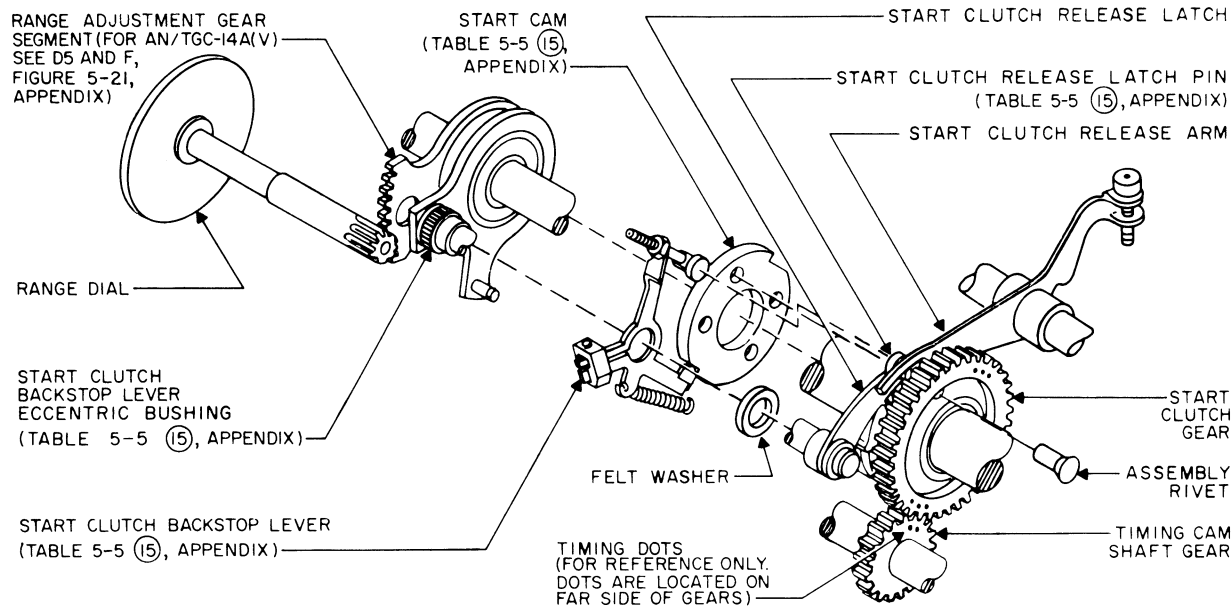

Figure 5-99. Start Clutch Release Mechanism, Exploded View

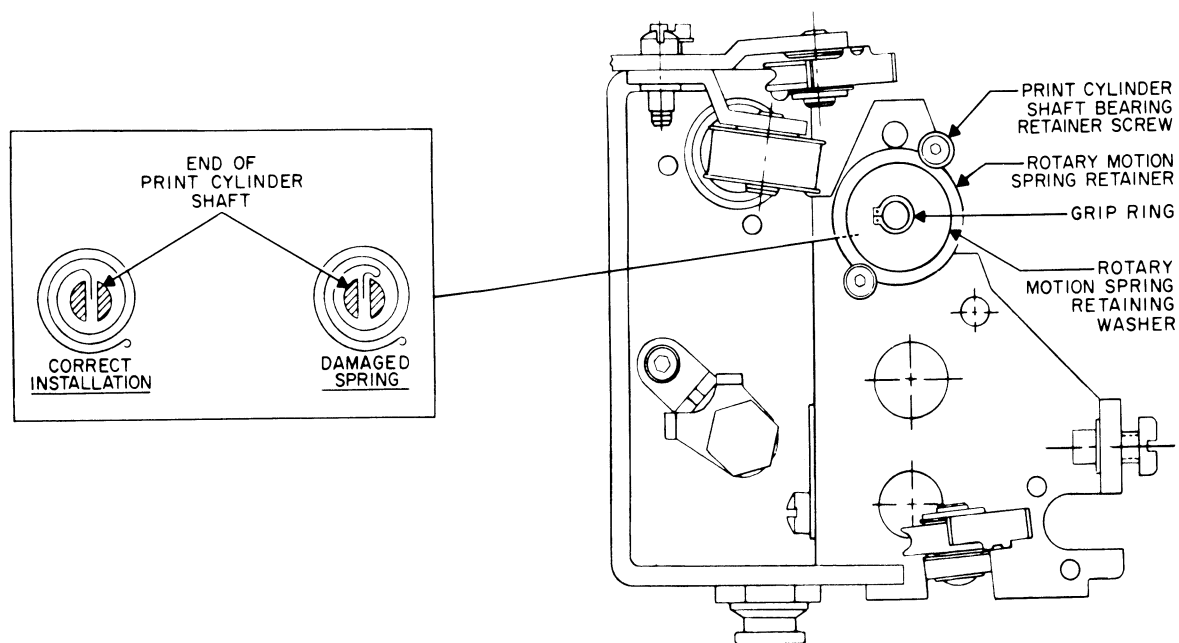
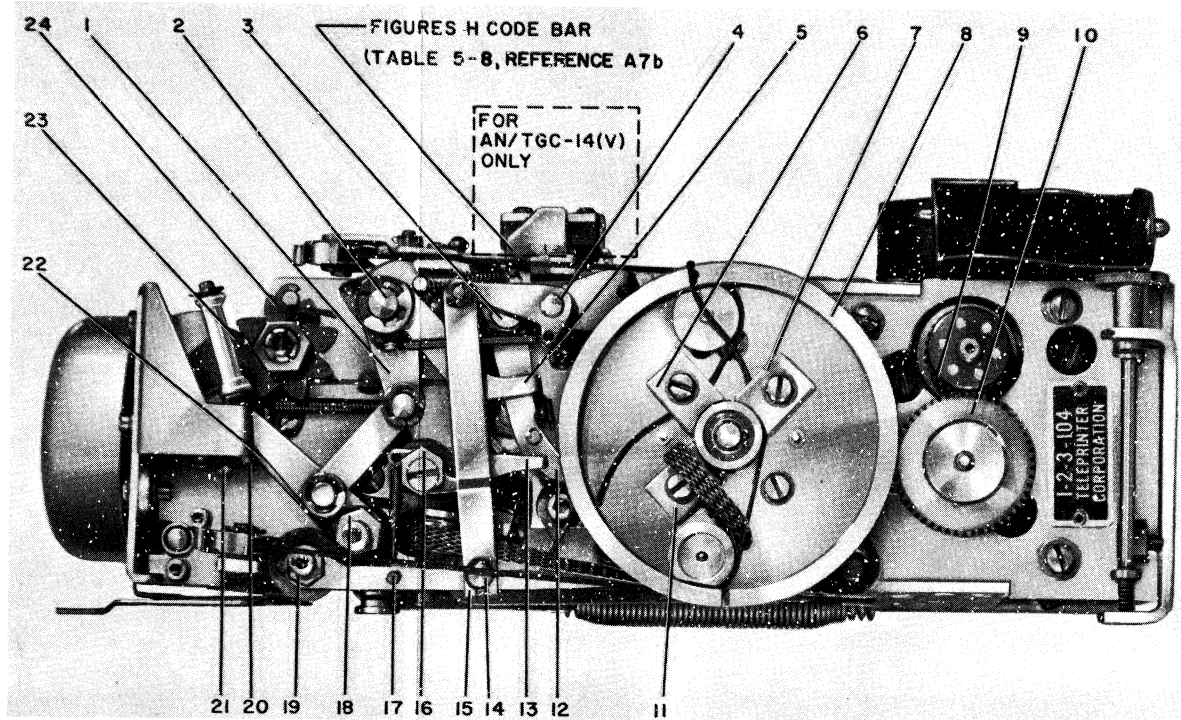

Figure 5-100. Rotary Cable Installation, Left-Side View



- |    |  |    |   |
|----|--|----|---|
| 1  | Function Shaft Terminal Lever            | 13 | Advance Suppression Latch                   |
| 2  | Character Advance Lever Shaft            | 14 | Check Pawl Eccentric Stud                   |
| 3  | Character Advance Pawl Eccentric Bushing | 15 | Check Pawl Link                             |
| 4  | Carriage Return Lever                    | 16 | Advance Suppression Latch Eccentric Bushing |
| 5  | Advance Prevent Lever Tab                | 17 | Check Pawl                                  |
| 6  | Return Cable Clamp                       | 18 | Rotary Detent Pawl Eccentric Bushing        |
| 7  | Print Hammer Cable Clamp                 | 19 | Check Pawl Eccentric Bushing                |
| 8  | Advance Drum                             | 20 | Rotary Detent Pawl Tab                      |
| 9  | Speed Change Gear                        | 21 | Rotary Detent Pawl Adjustment Screw         |
| 10 | Idler Gear                               | 22 | Rotary Detent Pawl                          |
| 11 | Lateral Control Belt Clamp               | 23 | Rotary Detent Pawl Pin                      |
| 12 | Character Advance Pawl                   | 24 | Index Wheel                                 |

Figure 5-101. Printer Assembly, Right-Side View



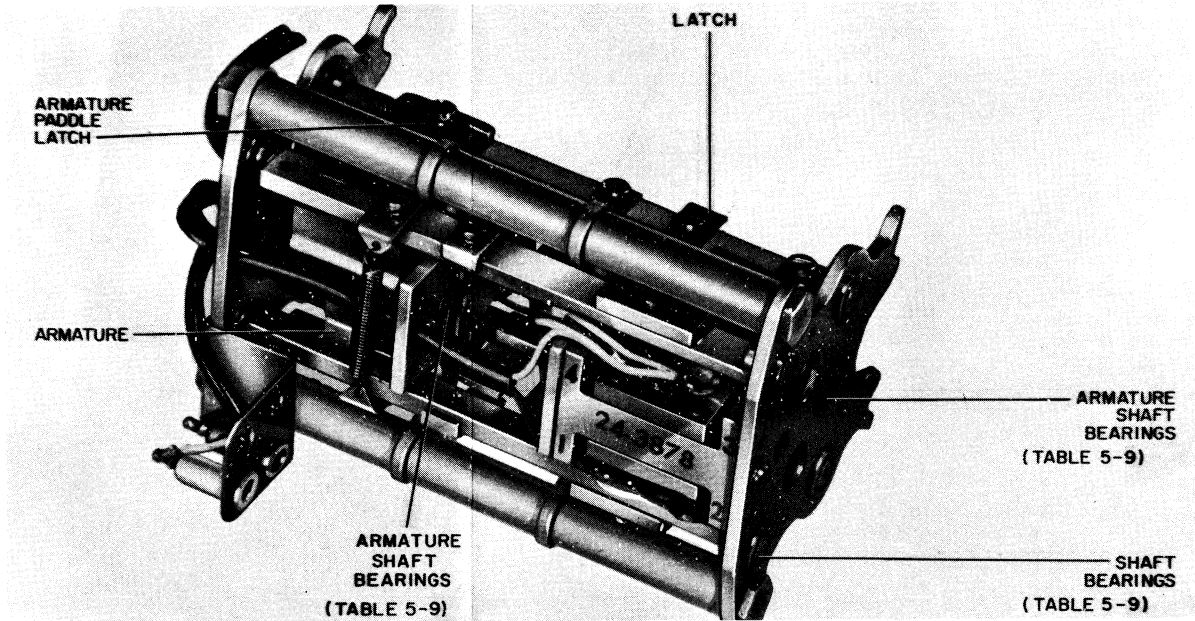

Figure 5-102. Selector Assembly, Lubrication Points

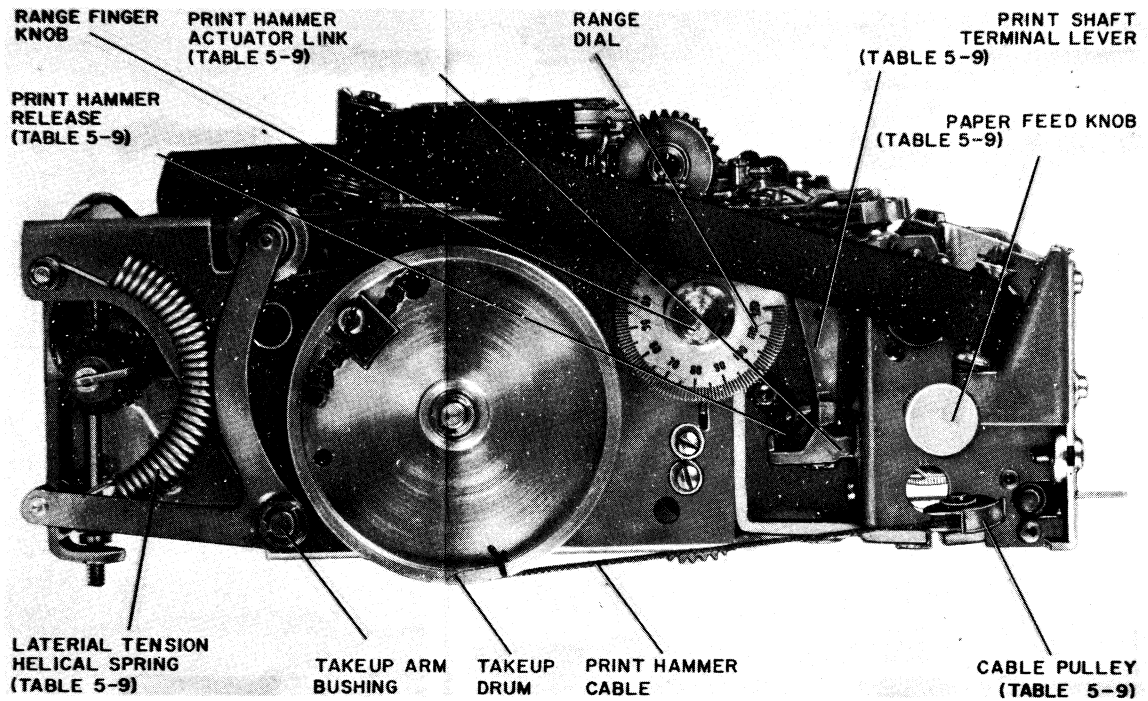

Figure 5-103. Printer Assembly, Left-Side View

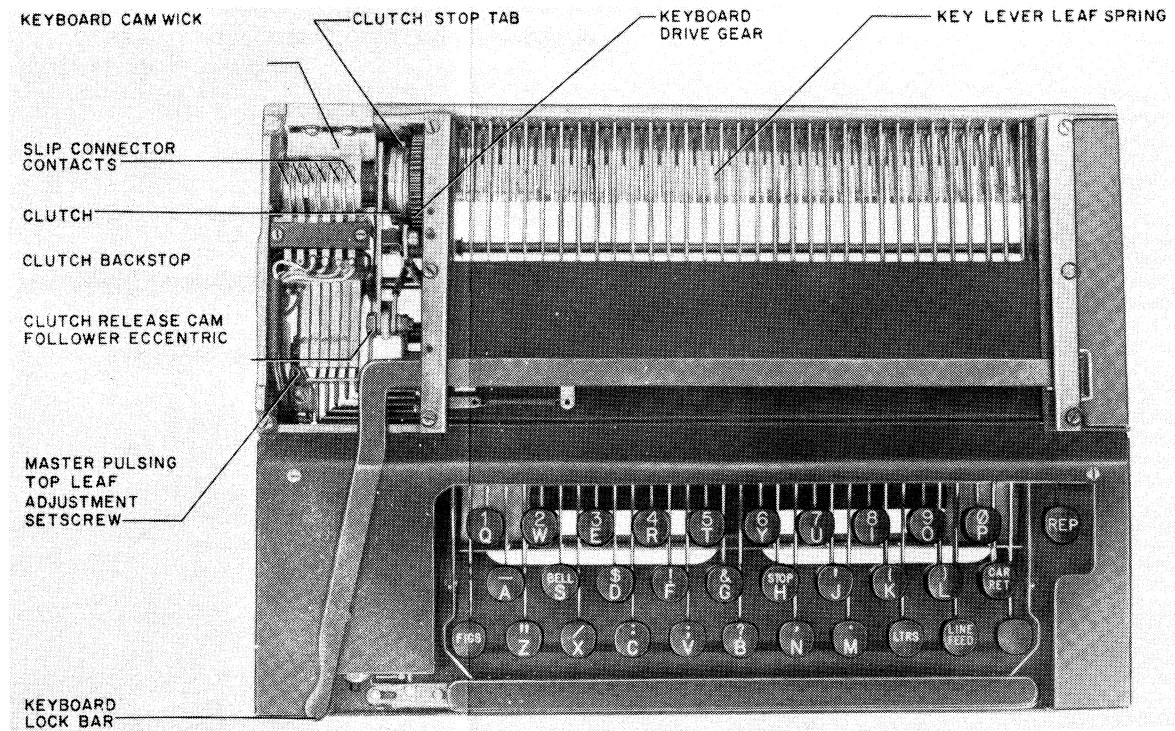

Figure 5-104. Keyboard Assembly, Top View (TT-318A/UG)

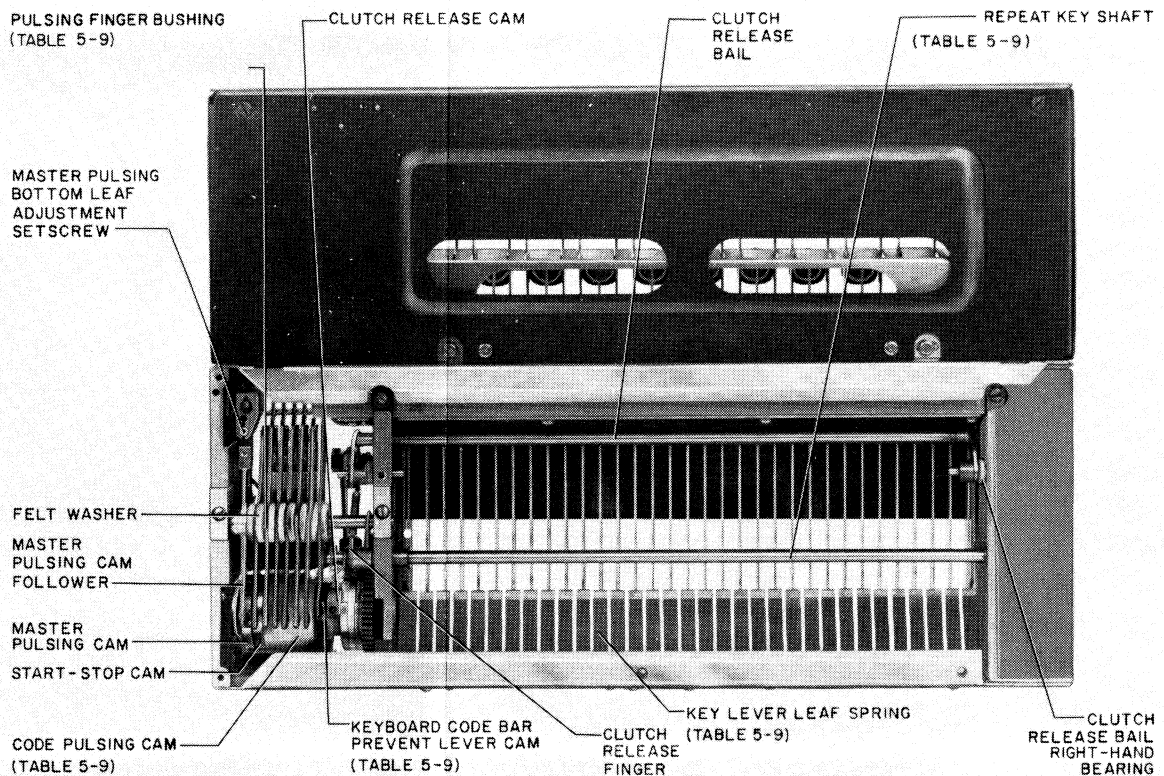



Figure 5-105. Keyboard Assembly, Bottom View (TT-318A/UG)

NOTES

1. REFERENCE DESIGNATIONS ARE ABBREVIATED. PREFIX THE DESIGNATION WITH THE UNIT NUMBER, OR ASSEMBLY DESIGNATION, OR BOTH.
2. ALL RESISTORS ARE 1/2 WATT ±5% AND VALUES ARE IN OHMS UNLESS OTHERWISE INDICATED.
3. ALL CAPACITORS ARE ±10% AND VALUES ARE IN MICROFARADS (UF) UNLESS OTHERWISE INDICATED.
4. ALL MEASUREMENTS OBTAINED WITH 20,000-OHMS-PER-VOLT METER. UNLESS OTHERWISE INDICATED, VALUES AT SIGNIFICANT TEST POINTS ARE TO COMMON GROUND, WITH ALL UNITS INTERCONNECTED, BUT WITH THE EQUIPMENT DEENERGIZED. SEE SECTION 4 FOR COMPLETE VOLTAGE READINGS.
5. PATCHED FOR SIMPLEX INTERNAL BATTERY OPERATION. FOR PATCHING OPTIONS SEE PARAGRAPH 2-9.
6. ALL DIODES ARE TYPE AFIN645 UNLESS OTHERWISE INDICATED.
7. THE SYMBOL  DENOTES A ZENER DIODE.

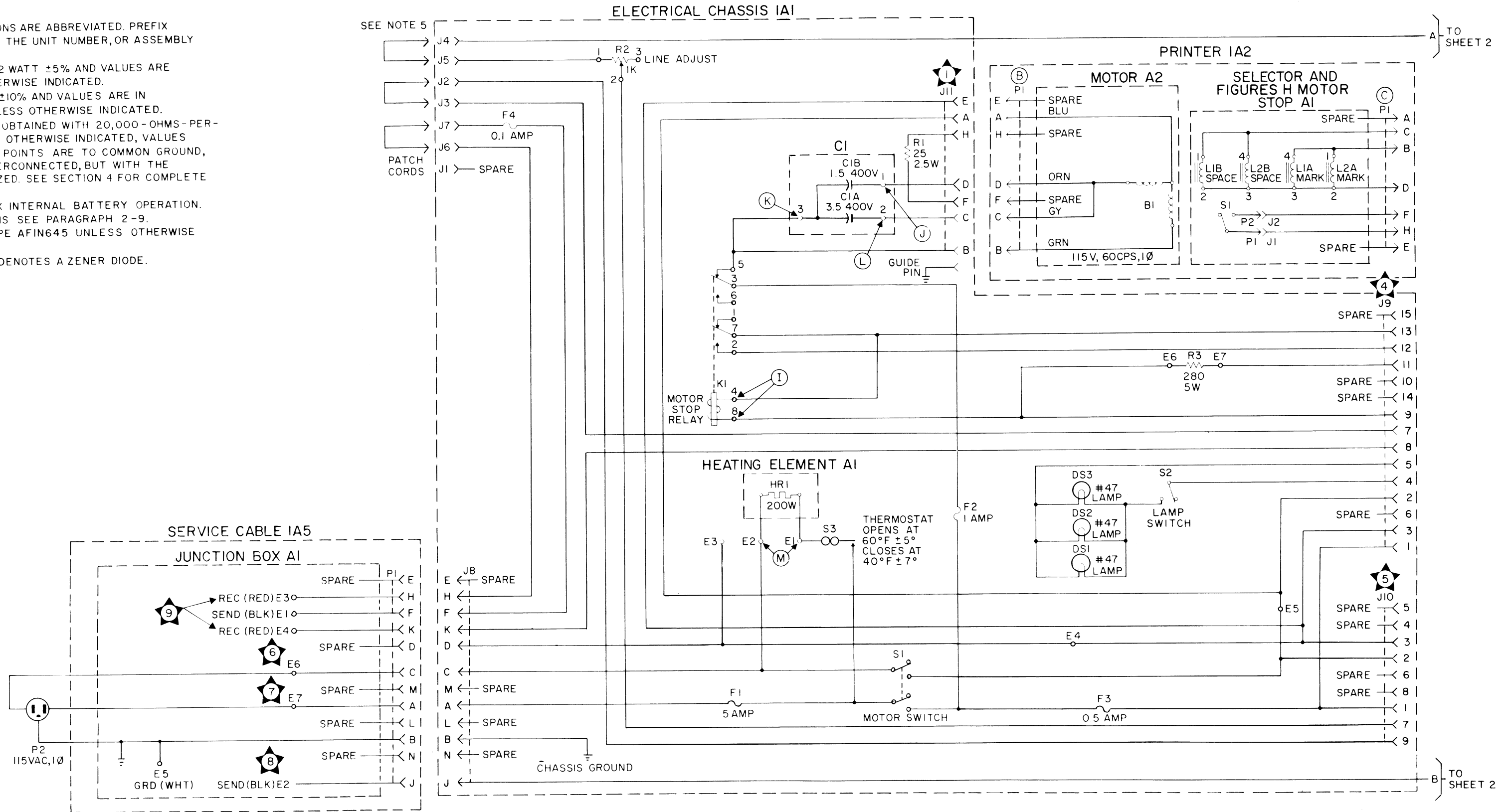

Figure 5-106. Teletypewriter Set AN/TGC-14(V), Schematic Diagram (Sheet 1 of 2)

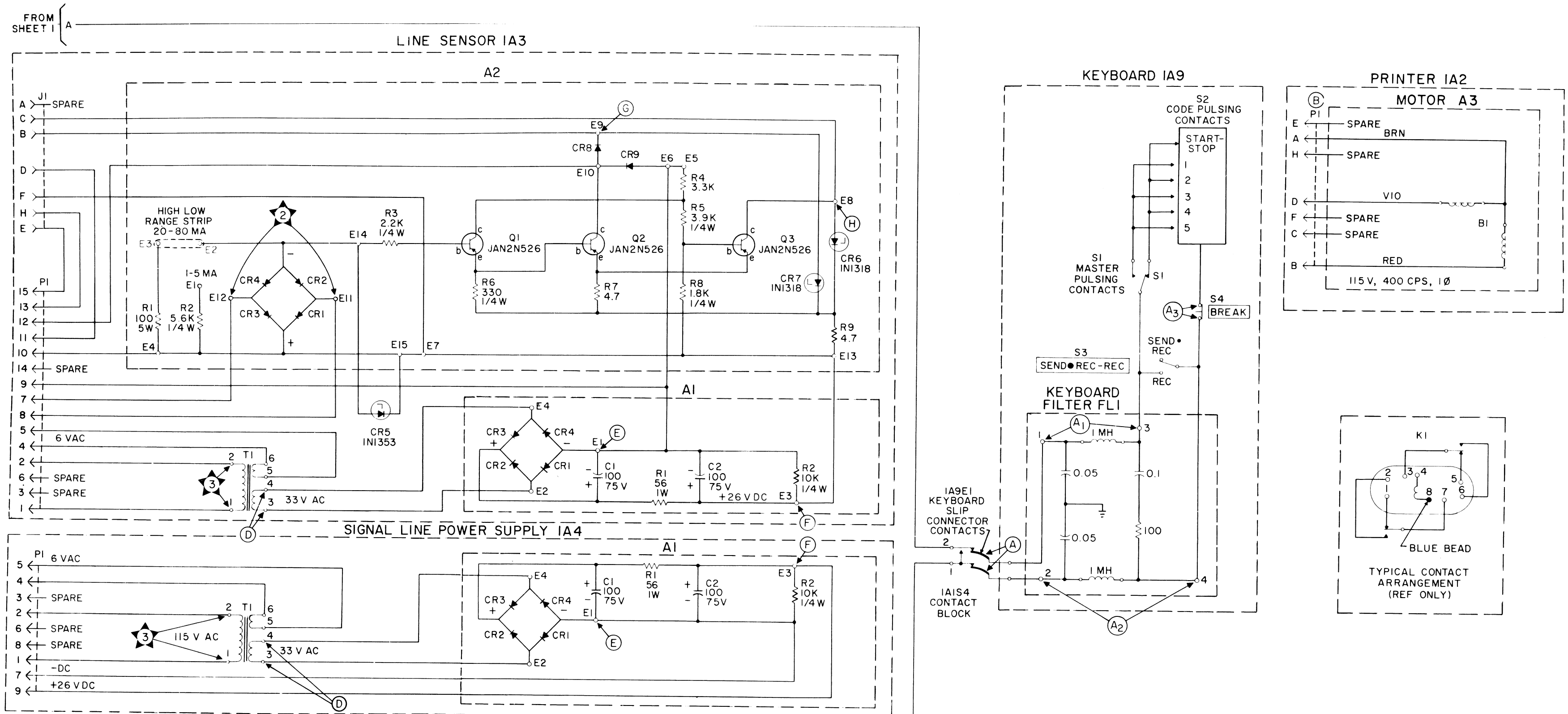



Figure 5-106. Teletypewriter Set AN/TGC-14 (V), Schematic Diagram (Sheet 2 of 2)

ORIGINAL

A-197/A-198

NOTES

1. REFERENCE DESIGNATIONS ARE ABBREVIATED. PREFIX THE DESIGNATION WITH THE UNIT NUMBER, OR ASSEMBLY DESIGNATION, OR BOTH.
2. ALL RESISTORS ARE 1/2 WATT ±5% AND VALUES ARE IN OHMS UNLESS OTHERWISE INDICATED.
3. ALL CAPACITORS ARE ±10% AND VALUES ARE IN MICROFARADS (UF) UNLESS OTHERWISE INDICATED.
4. ALL MEASUREMENTS OBTAINED WITH 20,000-OHMS-PER-VOLT METER. UNLESS OTHERWISE INDICATED, VALUES AT SIGNIFICANT TEST POINTS ARE TO COMMON GROUND, WITH ALL UNITS INTERCONNECTED, BUT WITH THE EQUIPMENT DEENERGIZED. SEE SECTION 4 FOR COMPLETE VOLTAGE READINGS.
5. PATCHED FOR SIMPLEX INTERNAL BATTERY OPERATION. FOR PATCHING OPTIONS SEE PARAGRAPH 2-9.
6. ALL DIODES ARE TYPE AFIN645 UNLESS OTHERWISE INDICATED.
7. THE SYMBOL  DENOTES A ZENER DIODE.

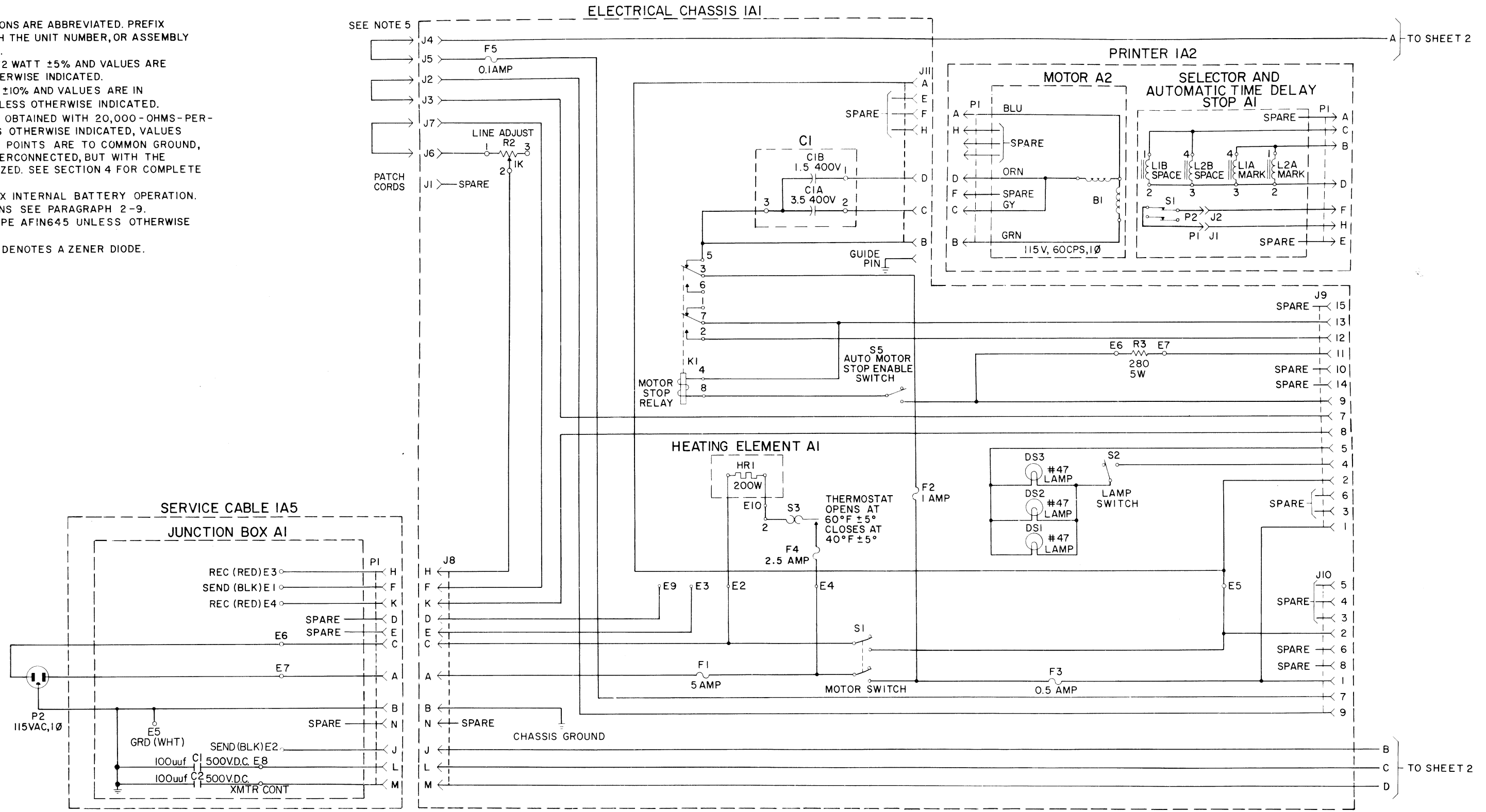

Figure 5-107. Teletypewriter Set AN/TGC-14A(V), Schematic Diagram (Sheet 1 of 2)

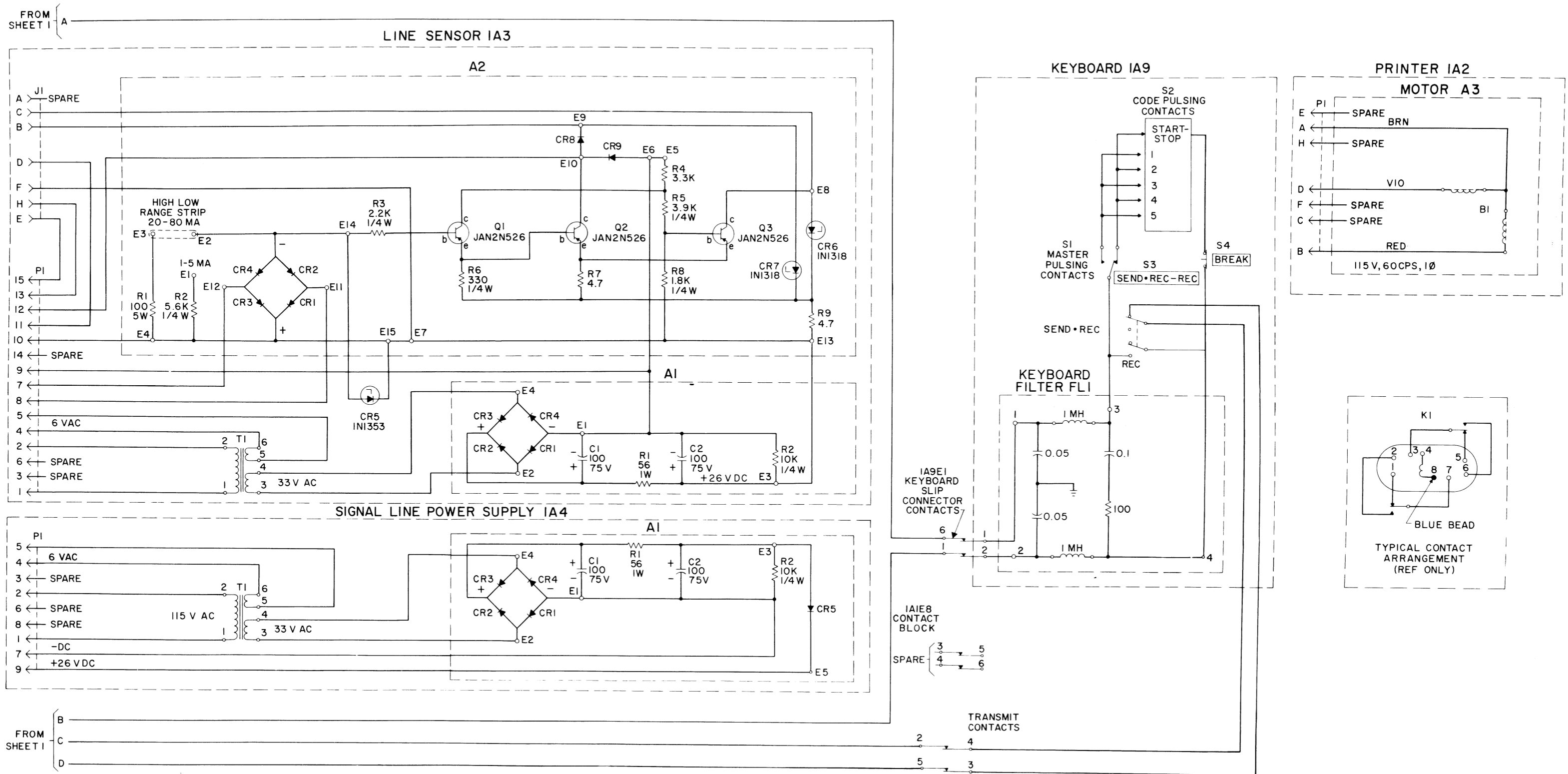

Figure 5-107. Teletypewriter Set AN/TGC-14A(V), Schematic Diagram (Sheet 2 of 2)

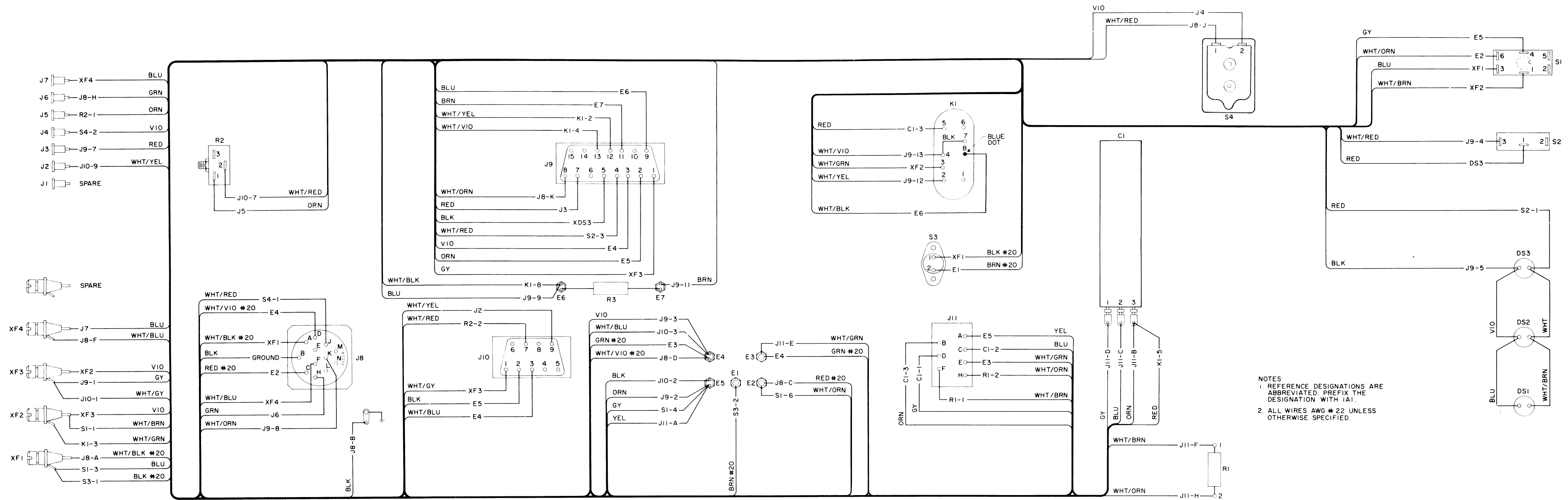

Figure 5-108. Teletypewriter Set AN/TGC-14(V), Wiring Diagram

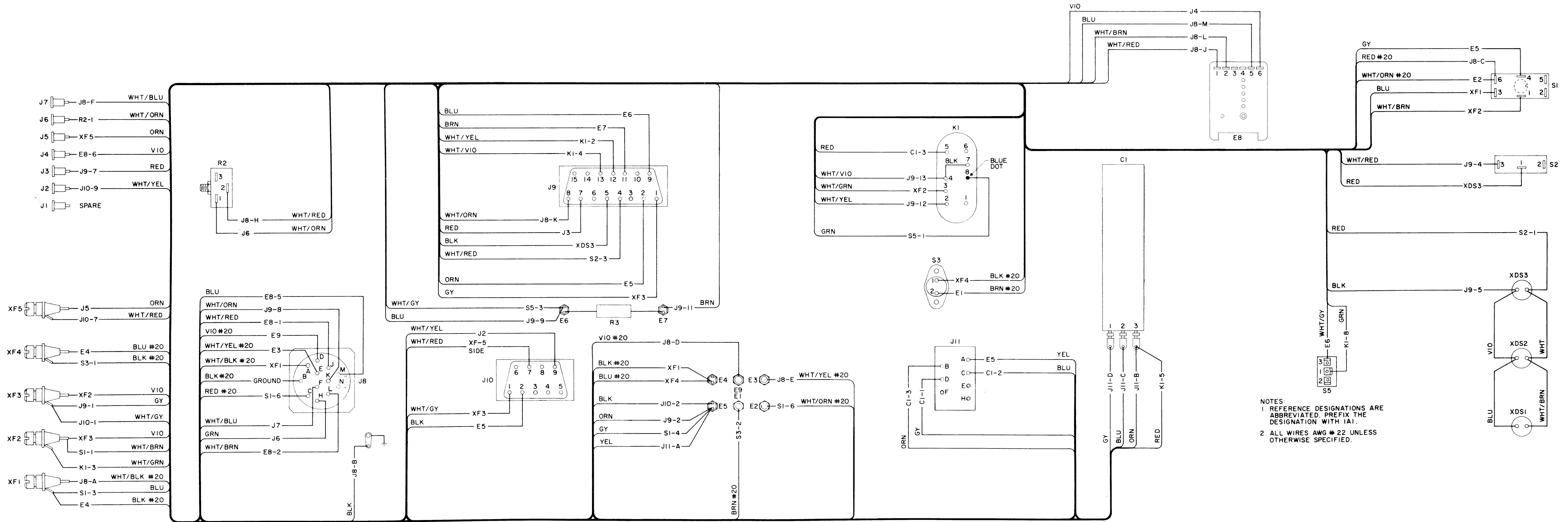
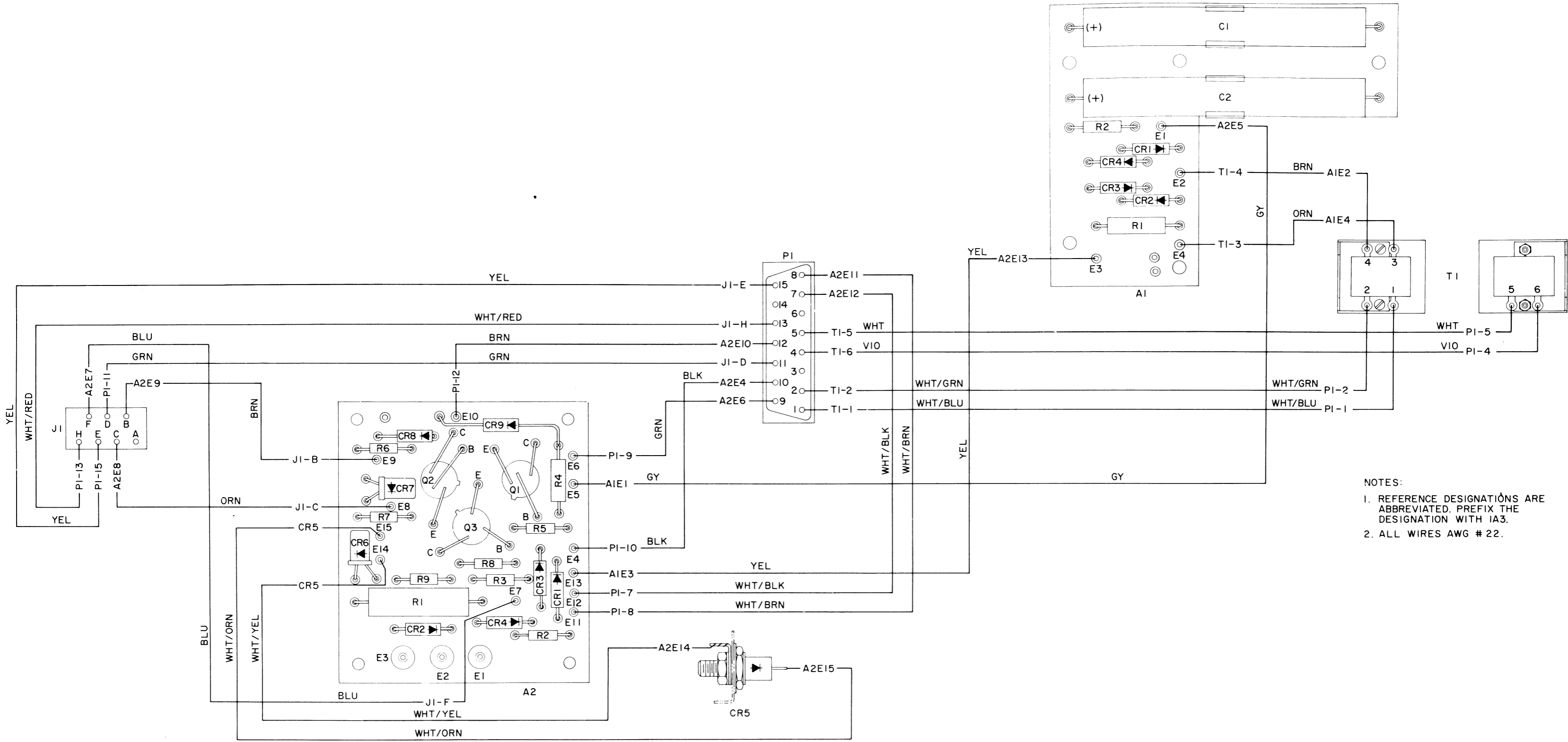

Figure 5-109. Teletypewriter Set AN/TGC-14A(V), Wiring Diagram





- NOTES:
1. REFERENCE DESIGNATIONS ARE ABBREVIATED. PREFIX THE DESIGNATION WITH IA3.
  2. ALL WIRES AWG # 22.

Figure 5-110. Line Sensor, Wiring Diagram

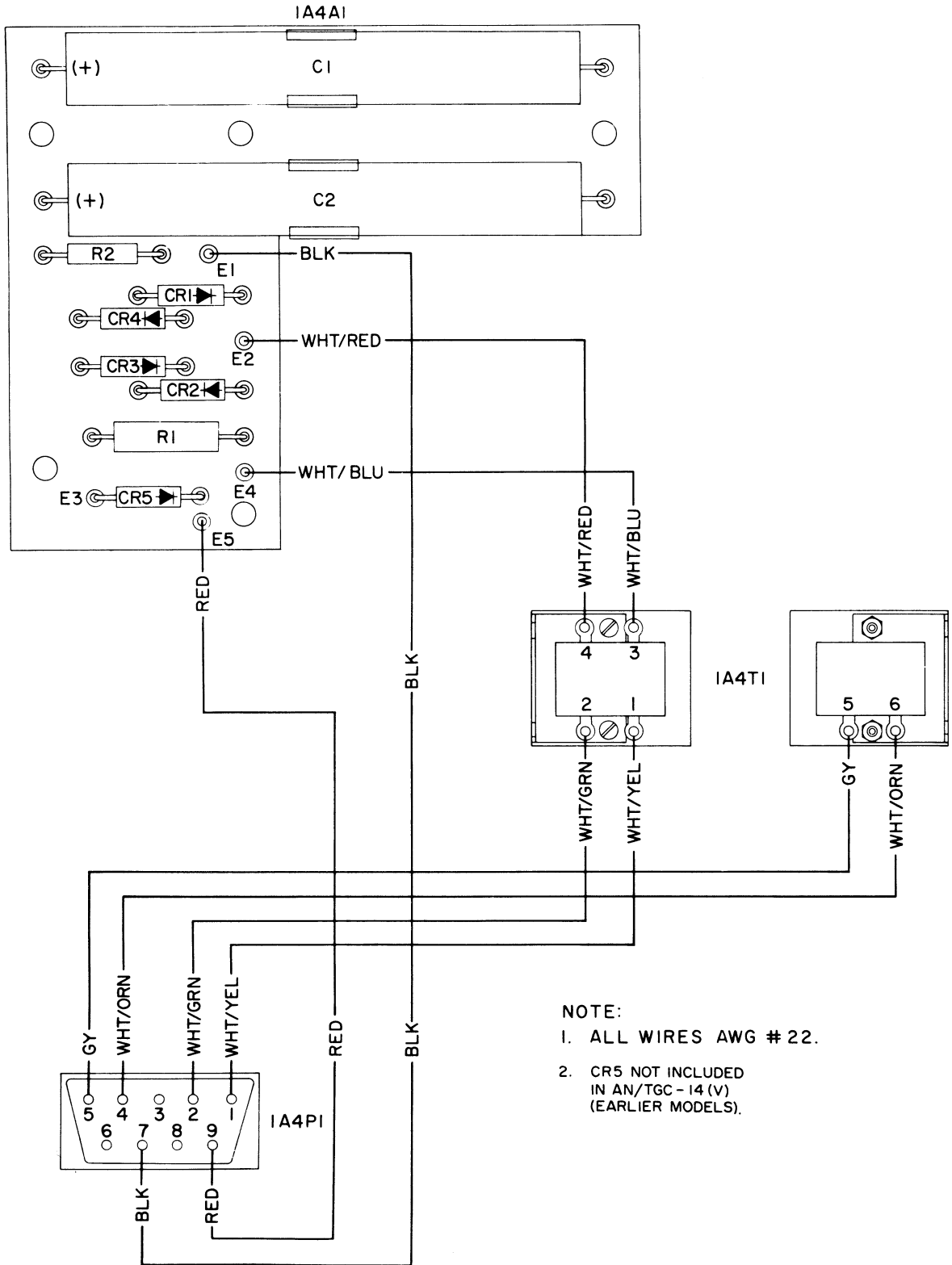

- NOTE:
1. ALL WIRES AWG # 22.
  2. CR5 NOT INCLUDED IN AN/TGC - 14 (V) (EARLIER MODELS).

Figure 5-111. Signal Line Power Supply, Wiring Diagram

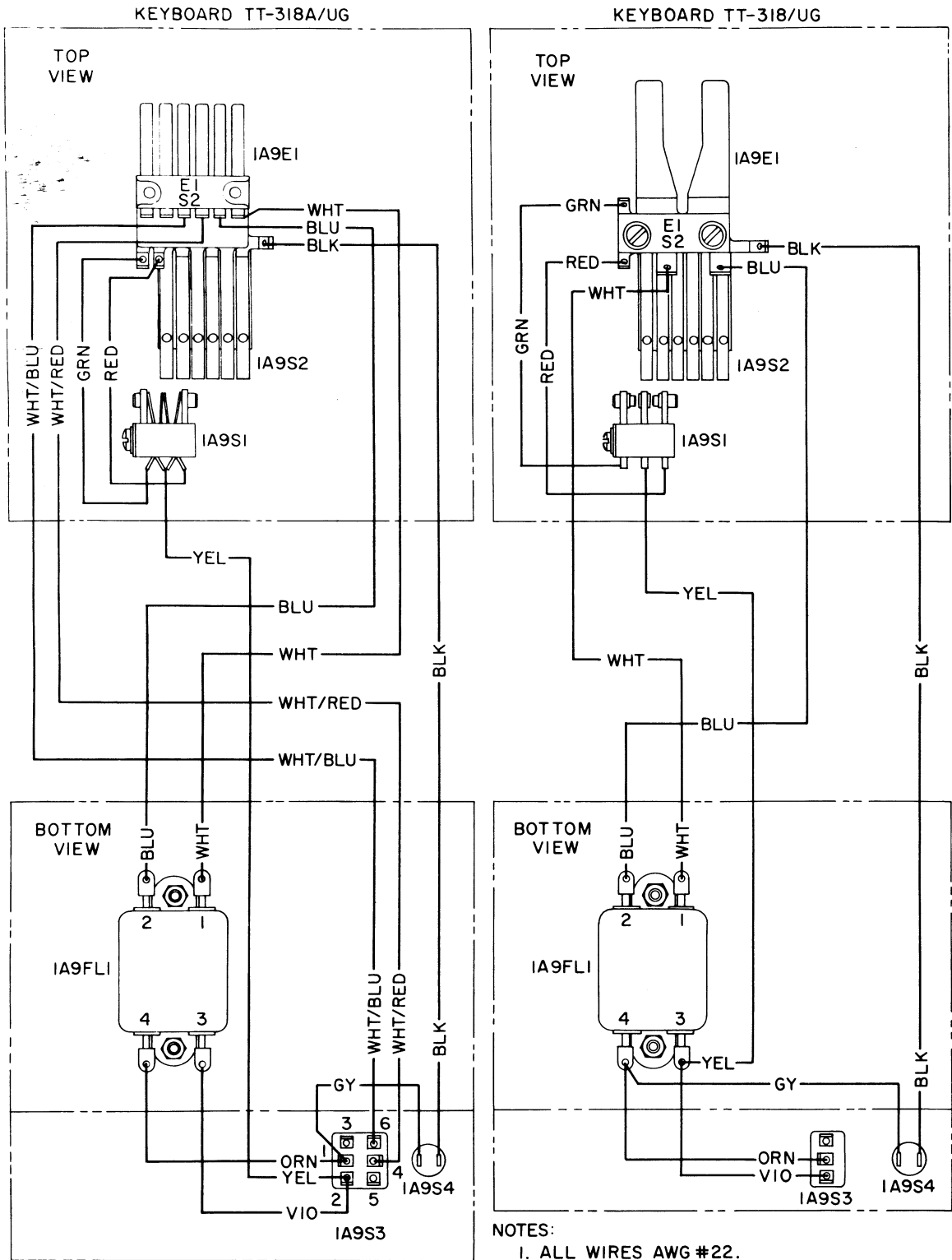

Figure 5-112. Keyboard TT-318/UG, Wiring Diagram

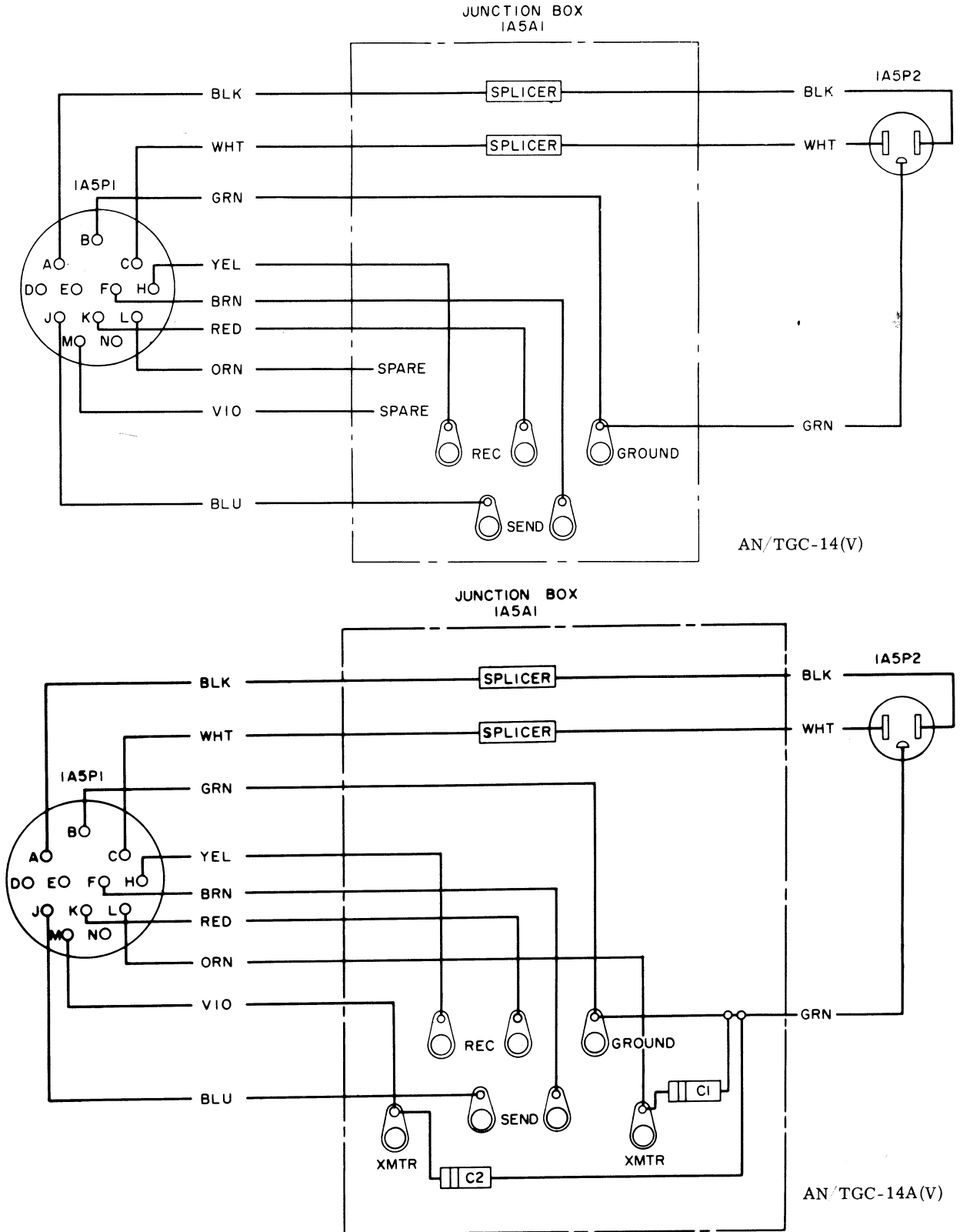

Figure 5-113. Service Cables. Wiring Diagrams, AN TGC-14(V) and AN TGC-14A(V)

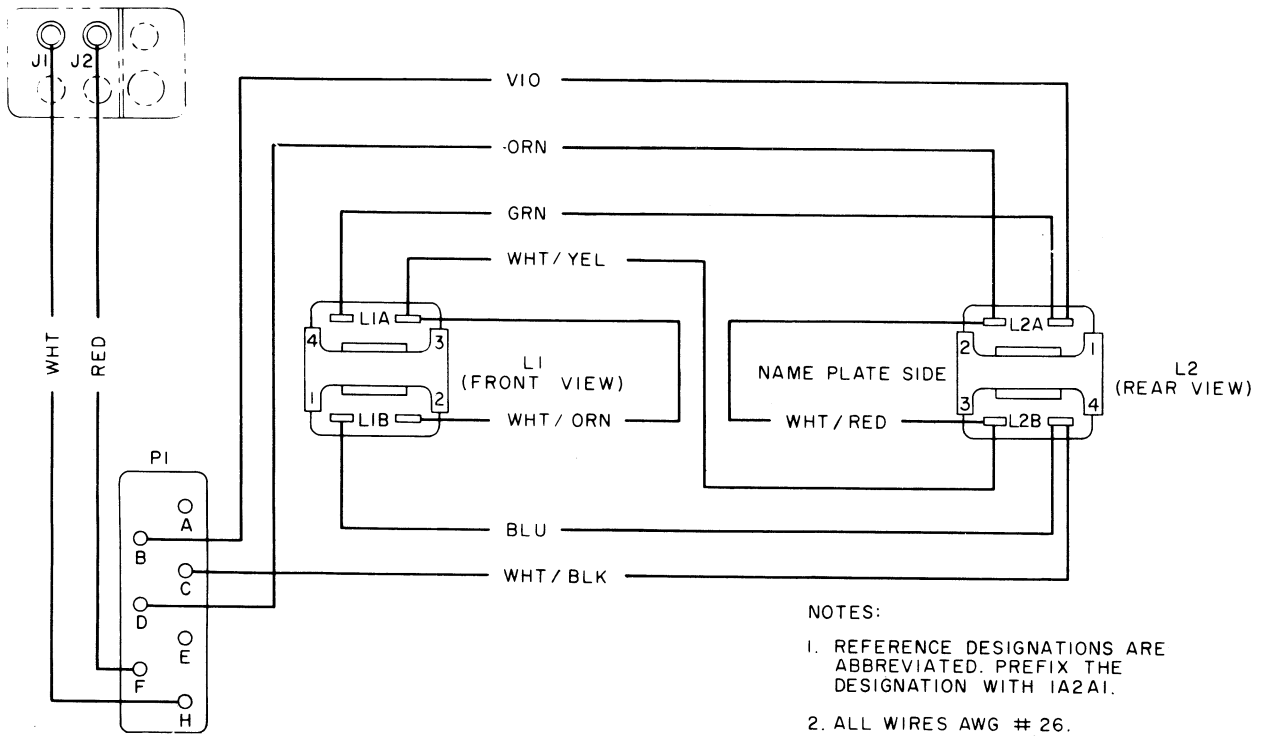

Figure 5-114. Selector, Wiring Diagram