

## INSTRUCTIONS FOR INSTALLING THE 162924 MODIFICATION KIT TO EQUIP A MODEL 28 MULTI-MAGNET REPERFORATOR (LARP) WITH AUXILIARY CAMS AND CONTACTS

### 1. GENERAL

- a. The 162924 Modification Kit provides the Model 28 Multi-Magnet Reperforators LARP5, 600, 700, and 800 with two auxiliary cams and contacts for various external control functions.
- b. The necessary wiring and wiring information are provided with the standard LARP unit.
- c. The two auxiliary cams mount on the function cam bearing sleeve of the LARP main shaft assembly permitting the contacts to operate only during a function cycle. Each auxiliary cam is held in place by two socket head set screws making it possible to adjust each cam independently for angular relationship.
- d. The auxiliary cams are identical and operate their associated contacts about forty percent "Make" and sixty percent "Break."
- e. The contacts are capable of carrying a 1 ampere current at 120 V.A.C. and 0.5 ampere current at 120 V.D.C. with proper arc suppression.
- f. The 162924 Modification Kit consists of:

2	2191	Washer, Lock	2	162967	Cam
2	7002	Washer, Flat	1	173806	Sleeve, Bearing
1	145796	Contact Assembly	4	173807	Screw, Set
2	151631	Screw, Hex.			
- g. For part numbers referred to and for parts ordering information refer to Teletype Parts Bulletin 1166B.

### 2. INSTALLATION

#### NOTE

Retain all parts unless otherwise instructed. References made to left or right, up or down, front or rear apply to the unit in its normal operating position viewed from the front.

- a. Remove the main shaft as follows:

- (1) Remove the 151632 Screw and 2191 Lock Washer that hold the 158745 Bearing Retainer.

(2) Remove the 151630 Screw, 2191 Lock Washer, and 70314 Flat Washer from the front end of the main shaft.

(3) Remove the 150040 Screw and 2191 Lock Washer that hold the 150000 Clutch Drum.

(4) Pull the main shaft from the unit leaving the function cam and clutch assembly behind.

#### NOTE

Do not lose any needle rollers when removing the main shaft.

- b. Remove and discard the 173340 Collar from the main shaft.
- c. Remove and retain the 151693 Screw and 2191 Lock Washer plus the 151630 Screw and 2191 Lock Washer in order to remove and retain the 156474 Bar with associated parts.
- d. Disassemble the function cam assembly and discard the 173203 Bearing Sleeve replacing it with the 173806 Bearing Sleeve and then reassemble the function cam assembly.
- e. Mount the two 162967 Auxiliary Cams to the function cam bearing sleeve so that the hubs of the auxiliary cams face away from the function cam with the 173807 Set Screws friction tight.
- f. Assemble the main shaft to the unit as follows:
  - (1) Relubricate the needle bearings by applying a light coat of grease to each needle race.

#### NOTE

Make certain there is no contamination of the needle rollers with foreign matter.

(2) Hold the function cam assembly in position and insert the main shaft through the rear bearing hole being careful not to lose any needle rollers as the shaft is moved forward.

#### NOTE

Hold the function cam assembly so that the clutch drum will not be pushed off the clutch when inserting the shaft.

(3) Replace the 151632 Screw and 2191 Lock Washer that hold the 158745 Bearing Retainer.

(4) Replace the 151630 Screw, 2191 Lock Washer and 70314 Flat Washer to the front end of the main shaft.

(5) Replace the 150040 Screw and 2191 Lock Washer that hold the 150000 Clutch Drum.

g. Remount the 156474 Bar and its associated parts with the mounting screws lock washers retained in 2.c.

#### NOTE

Adjust the 145796 Contact Assembly as given in Section 3 before mounting

h. Mount the 145796 Contact Assembly to the 156474 Bar using two 151631 Screws, 2191 Lock Washers and 7002 Flat Washers (do not tighten at this time).

i. Wire contacts per Wiring Diagram 3743WD.

### 3. ADJUSTMENTS

a. For standard adjustments refer to Teletype Model 28 Multi-Magnet Reperforator Bulletin 245B. Make the following adjustments.

b. Contact Gap

(1) The contact gap should be .015" to .025" when the cam follower is not in contact with the cam.

(2) To adjust, bend the contact stiffener.

c. Contact Pressure

(1) It should require from 2-1/2 to 5 ozs. to pull the contact away from its stiffener.

(2) To adjust, bend contact spring.

#### NOTE

Make the Contact Gap and Contact Pressure adjustments before mounting the contact assembly to the unit.

d. Lateral Cam

(1) The cam follower should ride on the full width of the cam.

(2) To adjust, reposition the auxiliary cam on the sleeve.

e. Timing

(1) As the cams have adjustable timing no specific requirement is given; however, the length of "break" and "make" of the contacts is adjustable by positioning the contact bracket and the timing sequence is adjustable by rotating the cams after adjustments are made, tighten 151631 Bracket Mounting Screws and 173807 Cam Set Screws.

#### 4. LUBRICATION

- a. For standard lubrication refer to Teletype Model 28 Multi-Magnet Bulletin 245B.
- b. Apply light film of grease to the operating surface of the Cams.

#### NOTE

There should be no oil or grease on the contact points of the contact assembly.

- c. Apply oil to the function cam bearing through oil hole in the bearing sleeve next to the function cam.

\*

\*

\*

5974S

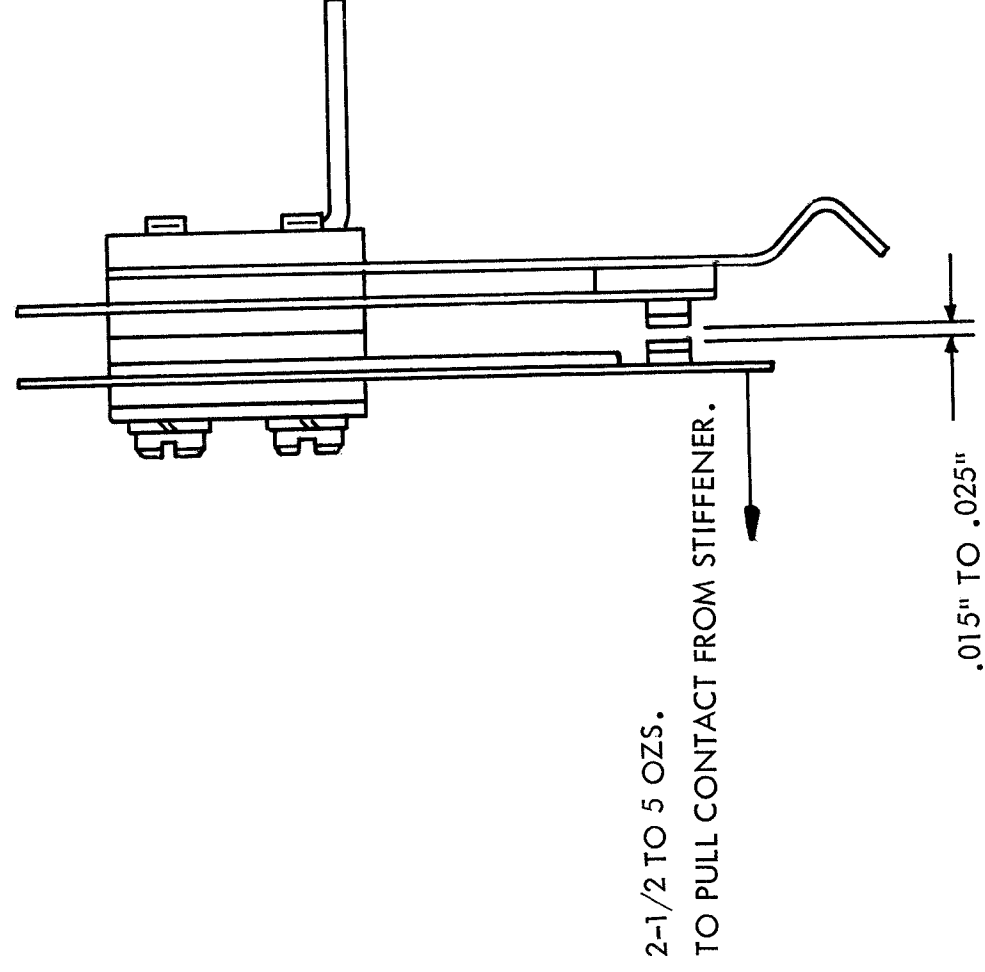

FIGURE 1.

