

INSTRUCTIONS FOR INSTALLING THE
195834 MODIFICATION KIT TO MAKE
LCXB800 COMPATIBLE WITH LRB301

1. GENERAL

1.01 The 195834 modification kit makes the LCXB800 Transmitter Distributor Base compatible with the LRB301 Reperforator Base.

1.02 The 195834 kit consists of:

<u>Qty</u>	<u>Part No.</u>	<u>Description</u>	<u>Qty</u>	<u>Part No.</u>	<u>Description</u>
1	2846	Washer	1	197765	Plate

1.03 For parts ordering information, other than the parts in the kit, see Teletype Bulletin 1187B.

2. INSTALLATION

2.01 Remove the LCXB800 from the cabinet by removing four 119653 retaining rings, four 82833 flat washers and four 192168 rubber rings.

2.02 Remove the following from the 192243 mounting plate: cable, terminal block, capacitor bracket, transmitter distributor with post attached, motor, and the answer-back.

2.03 Remount to the 197765 mounting plate the items removed in Paragraph 2.02 in reverse order.

2.04 Make the gear mesh adjustment in the following sequence: front motor pinion and transmitter gear, then rear motor pinion and answer-back idler gear. There should be 0.004" to 0.008" backlash at the closest point between gears. Gauge by feel.

2.05 Secure the 195834 modification kit to the cabinet by using four 192168 rubber rings, one 2846 washer on the right rear post, three 82833 washers and four 192168 retaining rings (see Figure 1).

3. ADJUSTMENTS AND LUBRICATION - Refer to the standardized information for standard adjustments and lubrication procedures for the following: Answer-Back, Transmitter Control Panel, Tape Chute, Idler Gear, and Answer-Back Assembly Spring Adjustments; Answer-Back Assembly Lubrication.

3.01 Do not lubricate answer-back driving pinion, idler gear, or main shaft gear.

3.02 Apply a light coat of grease to the transmitter drive pinion.

3.03 Apply a few drops of oil to each of the two oil holes on the motor.

*

*

*

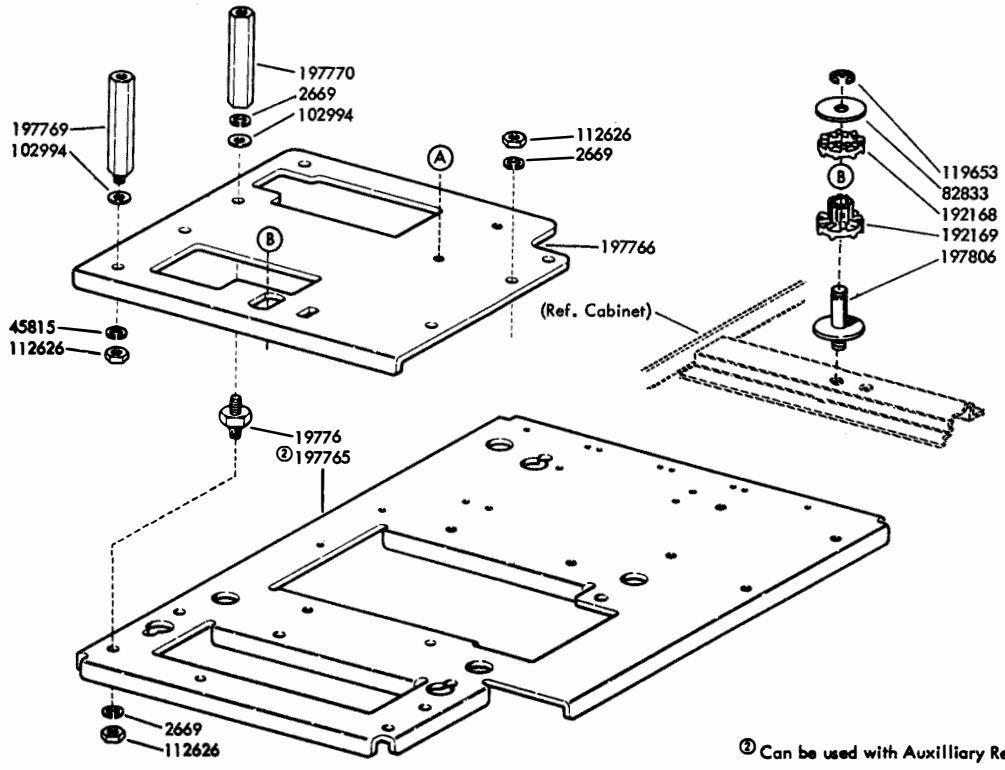
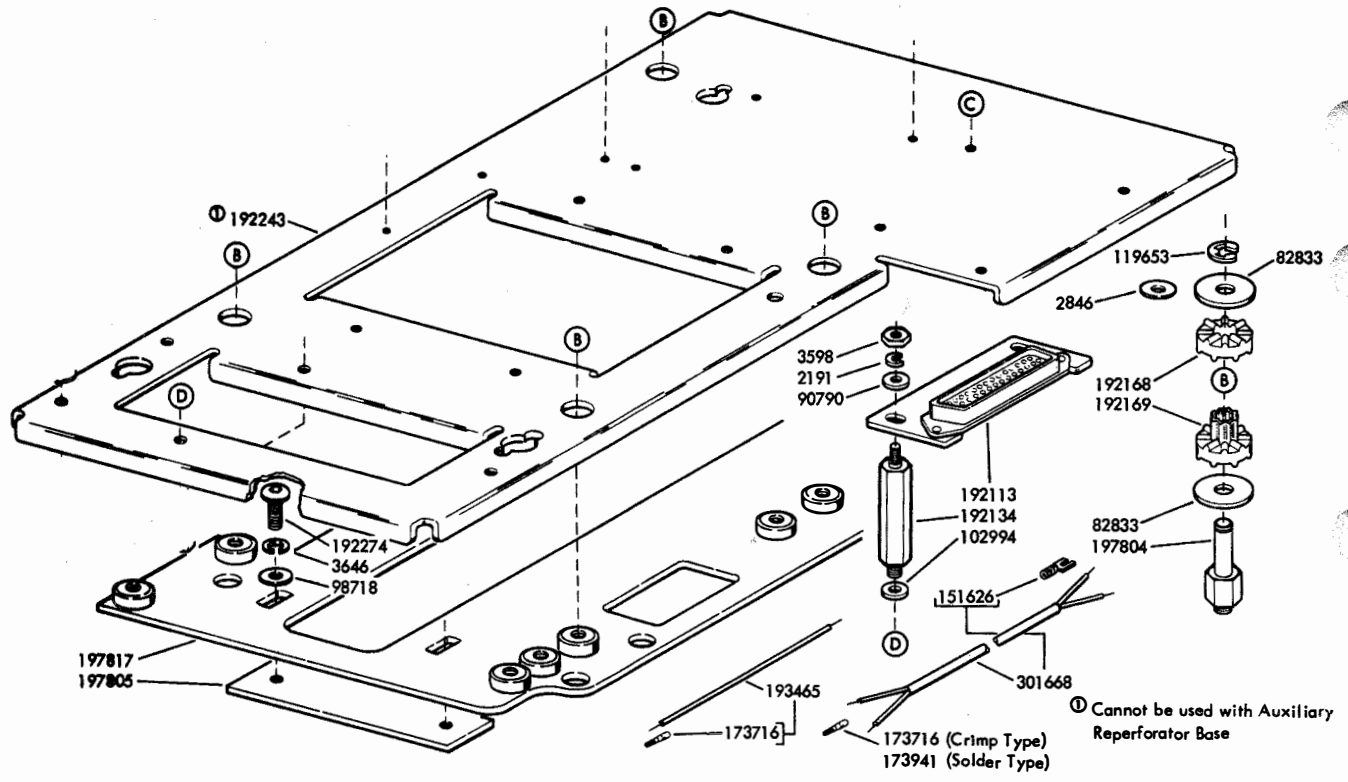

FIGURE 1.