

INSTRUCTIONS FOR INSTALLING THE 321940 MODIFICATION KIT
TO ADAPT MODEL 35 SPROCKET FEED PRINTER WITH IMPROVED PAPER AND FORM HANDLING

1. GENERAL

- 1.01 The 321940 modification kit is intended for use with the Model 35 8-1/2 inch sprocket feed printer.
- 1.02 The 321940 modification kit allows the use of a short form on which typing starts near the top edge of the form and each form is immediately torn off after completion. First line positioning of the form is accomplished through the normal CONTROL-VT function. The printer cover need not be opened to remove the form.
- 1.03 Modification kit 321940 consists of the following:
- | | | |
|---|--------|-------------------|
| 4 | 110743 | Lockwasher |
| 4 | 125011 | Flat Washer |
| 4 | 151637 | Screw |
| 1 | 321935 | Left Arm Bracket |
| 1 | 321936 | Right Arm Bracket |
| 2 | 321937 | Paper Guide |
| 1 | 321938 | Deflector |
| 1 | 321939 | Form Guide |
| 2 | 323656 | Plate with Hub |
- 1.04 For parts ordering information, other than those listed in the kit see Teletype Bulletin 1187B.

2. INSTALLATION

- 2.01 Remove the 55063 spring and the 128357 retainer from the 153678 bracket with shaft. Slide shaft out of its guide. See Figure 1.
- 2.02 Remove the 153726 paper tray.
- 2.03 Remove and save the 153839 screws, 2191 lockwashers, 8330 flat washers and 151629 nut plates from the 155565 and 155566 sprocket arms. Discard arms and the two 153685 stripper plates.
- 2.04 Assemble two (2) 153839 screws, two (2) 2191 lockwashers, two (2) 8330 flat washers, and two (2) 151629 nut plates to the 321935 and 321936 bracket arms. Tighten finger tight. See Paragraph 2.03.

SPECIFICATION 50607S

- 2.05 Insert both 321937 paper guides under platen making sure that paper guides are positioned above ribbon reversing shaft. See Figure 1.
- 2.06 Position the 323656 stripper plates in slots in platen. Place 321935 and 321936 bracket arms on printer. Insert 153678 bracket with shaft through right side frame, right bracket arm, right stripper plate, left stripper plate, left bracket arm, and left printer side frame.

Note: Shaft must pass through ears of sprocket cams on either end of platen.

- 2.07 Replace the 128356 retainer on the 153678 bracket with shaft.
- 2.08 Rotate the 153678 bracket with shaft counterclockwise until it stops. Replace the 55063 spring.
- 2.09 Place the 321938 deflector in place. Retain with four (4) 151637 screws, four (4) 110743 lockwashers, four (4) 125011 flat washers. See Figure 1.
- 2.10 The 154519 bracket with associated hardware and spring are no longer necessary but may remain on the unit.
- 2.11 Replace the 153726 paper tray. The 321937 paper guides must rest on top of the paper tray. See Figure 1.
- 2.12 Replace 192070 form guide on the 192067 plastic bubble with the 321939 form guide using existing hardware.

3. ADJUSTMENTS AND LUBRICATION

3.01 PAPER DEFLECTOR (Figure 2)

(a) Requirement: With the typebox in its upper-most position (hammer striking bottom row of type pallets), the clearance between the paper deflector and handle of the typebox clamp should be Min 0.015 --- Max 0.065 inch.

(b) To Adjust: Loosen both clampscrews. Position assembly horizontally to meet requirement.

3.02 PAPER GUIDE (Figure 3)

(a) Requirements: Sprocket pin should be centrally located in the paper guide slot.

(b) To Adjust: Loosen paper deflector mounting screws. Loosen clamp-screw. Position bracket. Tighten screws. Recheck paper deflector requirement.

3.03 PAPER TRAY (Figure 4)

(a) Requirement: The clearance between the paper guide and the front edge of paper tray should be Min. 0.050 --- Max 0.105 inch.

(b) To Adjust: Position the guide with its rear mounting screws loosened.

3.04 LUBRICATION: None required.

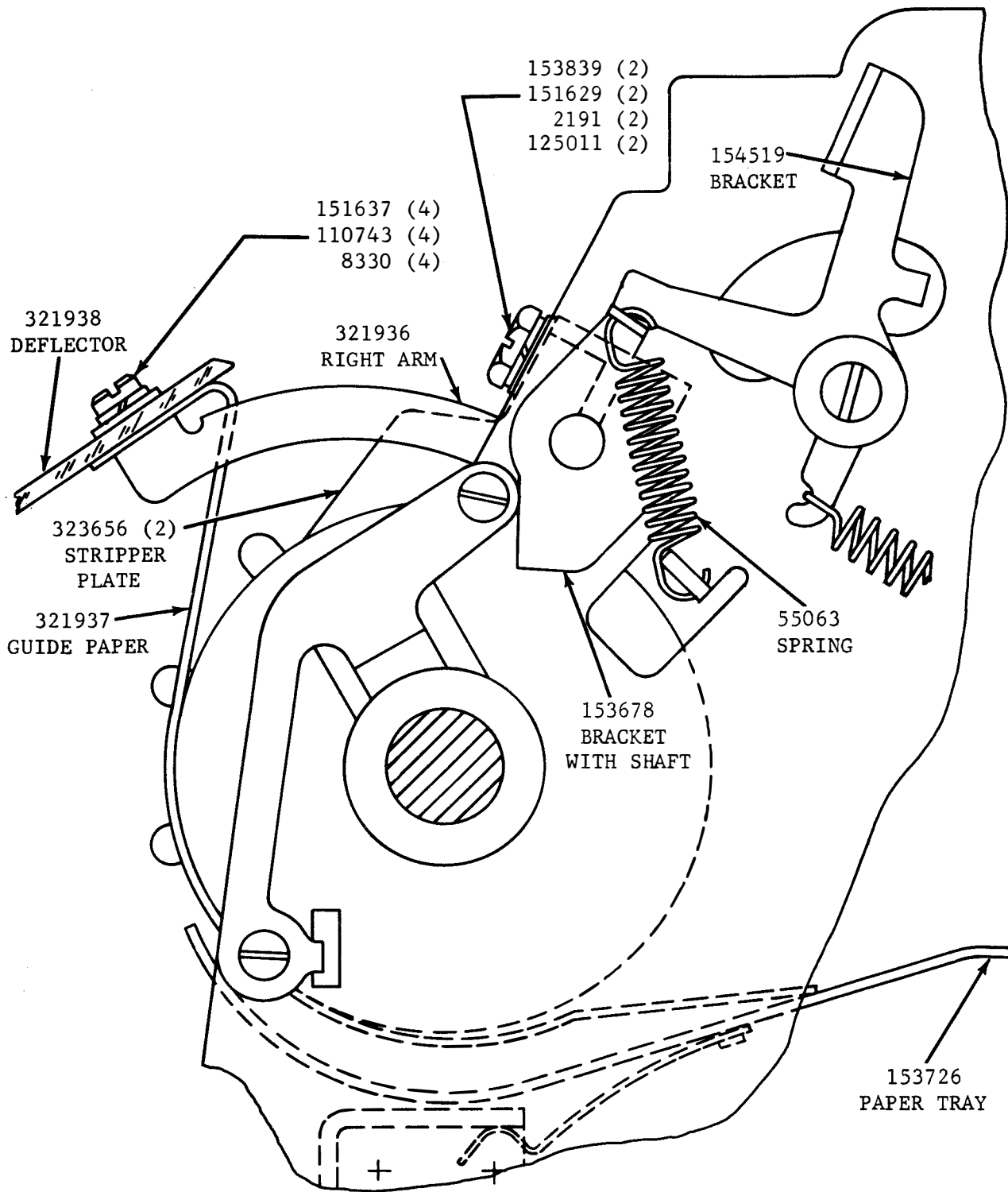

Figure 1

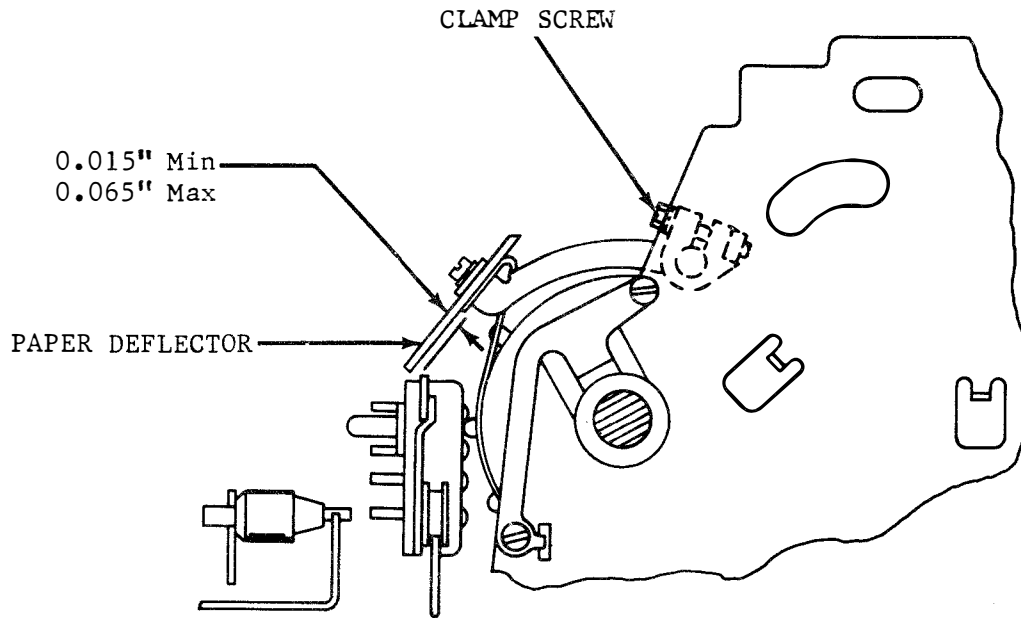

Figure 2

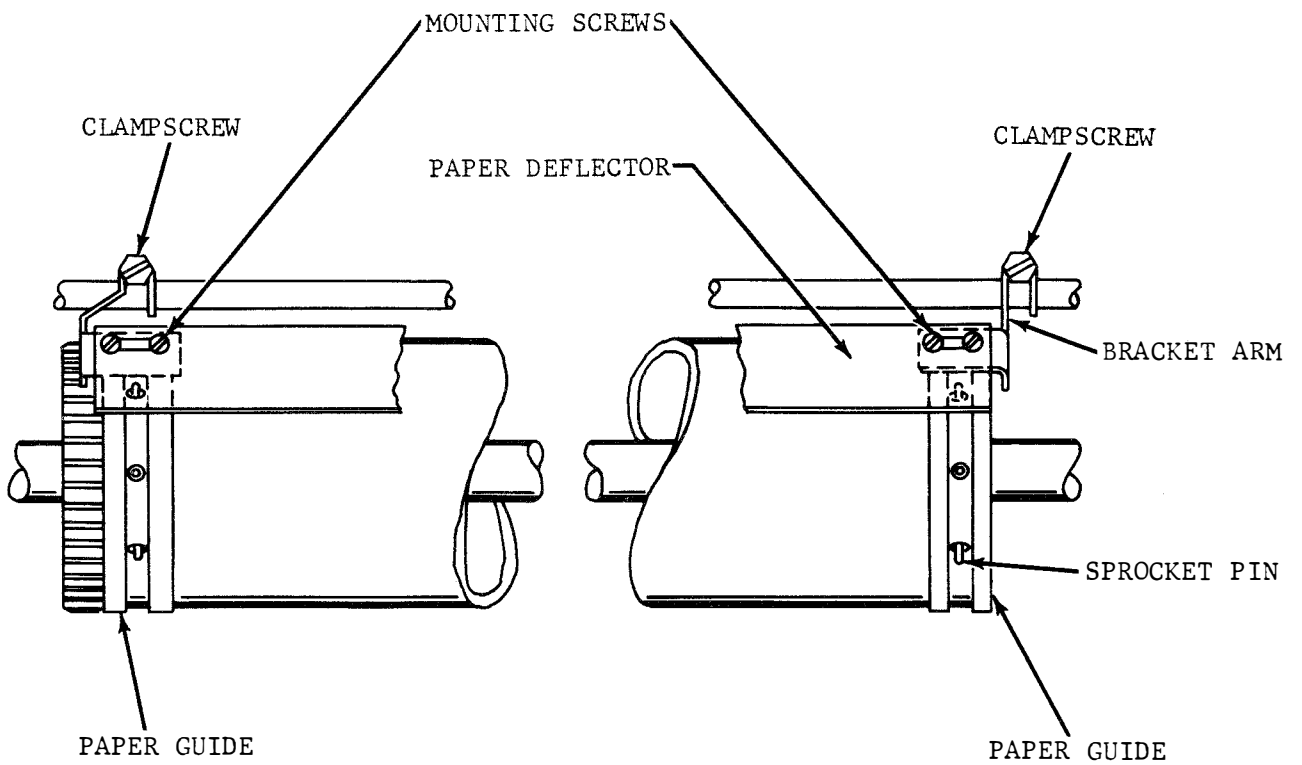
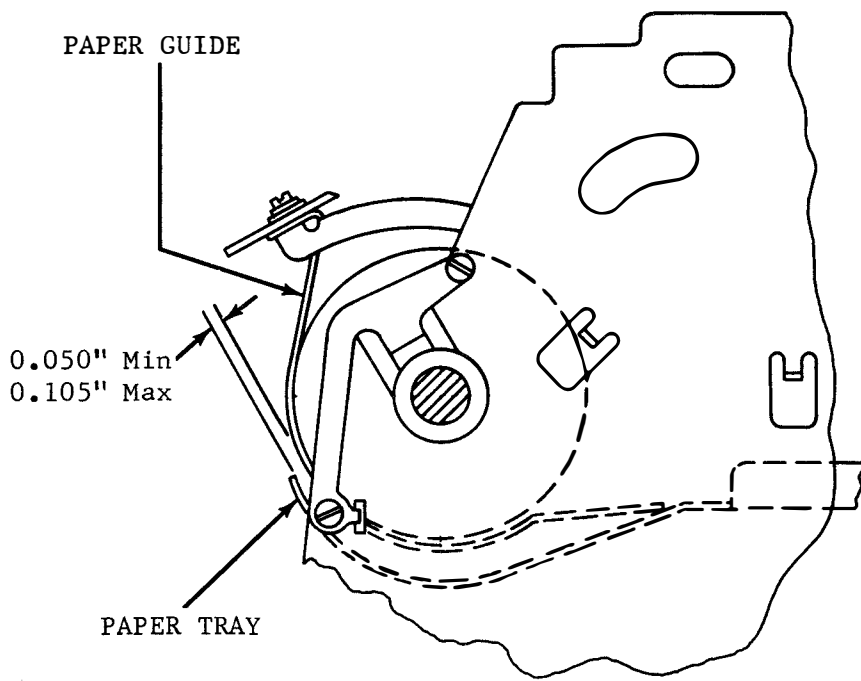

Figure 3



MOUNTING SCREWS

