

INSTRUCTIONS FOR INSTALLING THE 193988, 193989, 193992,
AND 193993 MODIFICATION KITS TO MAINTAIN SLACK TAPE
FOR MODEL 28 AND 35 PERFORATORS AND REPERFORATORS

1. GENERAL

a. The 193988, 193989, 193992, and 193993 modification kits, when installed on Model 28 or 35 perforators and reperforators, maintain the proper spacing between code holes (ten-holes-per-inch) under varying tape loads. The kits maintain a minimum of 0.10 inch of slack tape in front of the punch so that the feed mechanism does not pull against taut tape.

b. The 193988 modification kit for the Model 28 or 35 typing reperforator consists of:

3	2191	Lockwasher	1	153537	Screw
1	7002	Washer, Flat	1	193966	Bracket
1	90789	Washer, Flat	1	193968	Post
1	110743	Lockwasher	1	193972	Extension
1	119648	Ring, Retaining	1	193974	Depressor, Tape
1	119650	Ring, Retaining	1	194117	Plate, Clamp
1	125015	Washer, Flat	1	194118	Spring, Torsion
1	151442	Screw	1	194122	Platform w/Tape Guide
2	151722	Screw			
2	151880	Nut	1	194123	Screw w/Disc
1	153239	Roller	1	327120	Post

c. The 193989 modification kit for the Model 28 or 35 Perforator is the same as 193988 except it omits 193972 extension and the 151442 screw and adds the following:

2	2191	Lockwasher	1	152400	Plate, Selector Mounting
1	3598	Nut			
2	151632	Screw	1	193976	Bail Assembly, Rocker

d. The 193992 modification kit for the Model 28 or 35 Typing Perforator is the same as 193988 except it omits the 151442 screw and adds the following:

2	2191	Lockwasher	2	151632	Screw
1	3598	Nut	1	152400	Plate, Selector Mounting

e. The 193993 modification kit for the Model 28 or 35 Reperforator is the same as 193988 except it omits 193972 extension and adds one 193976 bail assembly, rocker.

NOTE

Certain parts and modification kits are necessary to provide rigid tape paths when modified units are mounted in the following manner:

- (1) On an ASR Set, the 194076 modification kit is required.
- (2) In the ASR auxiliary position, the 194077 modification kit is required.
- (3) On the LRB, the 195658 tape guide assembly must be ordered separately to replace the 156470, 163868, or 193837 tape guide.
- (4) On the LMRB, discard the 161529 tape guide.
- (5) On the LTRK, replace the 161925 tape guide with a 194170 tape guide and the 161926 tape guide, with a 194171 tape guide using the same mounting hardware.
- (6) On the LTHS, the 194169 modification kit is required.

NOTE

The slack tape mechanism is driven by the rocker bail of the perforator or reperforator. As the rocker bail moves toward the left, it rotates the tape depressor in a clockwise direction. When the tape depressor rotates, it pushes the tape down between the end of the tape platform and a post, causing a loop of tape to be formed. Since the tape is prevented from moving in a direction opposite to that of the tape feeding by the wedging action of a clamp plate, mounted on a common post with the tape depressor, the loop of slack tape is formed only from tape pulled from the roll of tape. When the rocker bail moves back toward the right, the tape depressor is rotated in a counter-clockwise direction leaving a loop of load-free tape for the punch to feed.

f. For parts ordering information on all above except LTHS refer to Teletype Parts Bulletin 1167B. Parts ordering information for LTHS can be found in Teletype Parts Bulletin 1168B.

2. INSTALLATION (See attached figures)

NOTE

The following installation instructions are for all units. Take careful note of your own requirements.

a. If the unit being modified is a Model 28 or 35 Perforator or a Model 28 Reperforator, remove the 158941 rocker bail assembly and install a 193976 rocker bail assembly reusing all the old bail mounting hardware. See Figure 1.

(1) Place the 153239 roller over the stud on the rocker bail, and lock it to the stud with a 119648 retaining ring.

b. If the unit is a Model 28 or 35 Perforator or a Model 28 or 35 Typing Perforator, remove and save the 3598 nut and 2191 lockwasher used to attach the 156472 spring post to the frame.

(1) Place the 152400 selector mounting plate over the 156403 main shaft bearing disc and threaded portion of the 156472 spring post.

(2) Secure the selector mounting plate into position by replacing the 2191 lockwasher and 3598 nut retained in Paragraph 2. b.

c. If the unit being modified is a Model 28 or 35 Typing Reperforator or a Model 28 or 35 Typing Perforator mount the 193972 extension to the rocker bail assembly by removing and saving the 151631 screw, 2191 lockwasher and 156399 nut used to mount the 156871 operating blade mounting bail. Refer to Figure 2.

(1) Assemble the 153239 roller to the 193972 extension with a 119648 retaining ring.

(2) Mount the 193972 extension to the rocker bail with the roller up to the right and front of the rocker bail using the 151631 screw, 2191 lockwasher and 156399 nut saved above in the same mounting holes.

(3) Assemble the 193974 tape depressor, the 90789 washer and the 119650 retainer to the 193966 bracket w/stud. The tape depressor mounts on the stud so that the drive arm is on the opposite side of the bracket. Assemble the 327120 post to the 193966 bracket and lock it in place with a 151880 nut. Assemble the 194123 screw w/disc to the 194117 clamp plate with a 110743 lockwasher and a 151880 nut, so that the disc (head of the screw) faces down when the legs are up. Assemble the clamp plate and the 194118 torsion spring to the 327120 post. The clamp plate shall be mounted with the legs up and the tab forward. Hook the formed end of the torsion spring over the 193966 bracket.

(4) Mount the 193968 post to the 193966 bracket w/stud using a 153537 screw, and 2191 lockwasher.

(5) Mount the 194122 tape platform to the 193966 bracket w/stud with two 151722 screws, two 2191 lockwashers, a 7002 flat washer (upper mounting hole), and a 125015 flat washer (lower mounting hole).

g. If the unit being modified is equipped with a 156475 or 176640 tape guard, proceed as follows:

(1) Remove the tape guard replacing it with the 193966 bracket w/stud using the same mounting hardware as the tape guard, except replace the right mounting screw with a 151442 screw.

NOTE

Make sure that the slot in the drive arm on the tape depressor is over the 153239 roller.

h. If the unit being modified is not equipped with a tape guard, then assemble the 193966 bracket w/stud to the selector plate with the 151632 screw and 2191 lockwasher for the lower leg of the bracket, and 151632 screw, 2191 lockwasher and 3598 nut for the upper leg.

NOTE

Make sure that the slot in the drive arm on the tape depressor is over the 153239 roller.

3. ADJUSTMENTS AND LUBRICATION

a. For standard adjustments and lubrication procedure refer to appropriate Teletype Adjustment and Lubrication Bulletins. (Bell System refer to standardized information.)

- (1) Typing Reperforator refer to Teletype Bulletin 247B.
- (2) Perforator Transmitter refer to Teletype Bulletin 250B.
- (3) Non-Typing Reperforator refer to Teletype Bulletin 256B.
- (4) Reperforator Transmitter Set refer to Teletype Bulletin 248B.

b. Refer to attached figures for adjustments and lubrication.

*

*

*

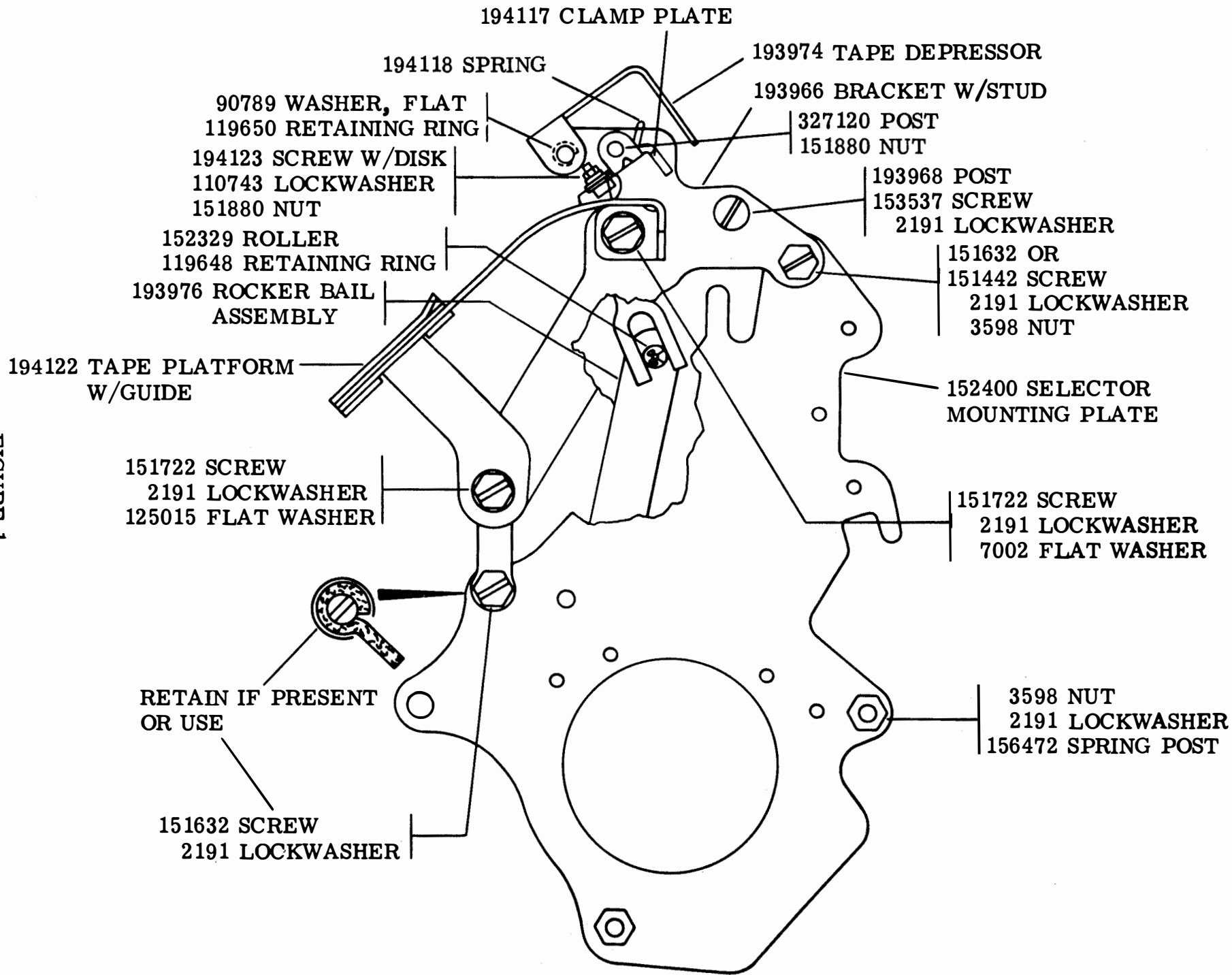

FIGURE 1

50247S

194117 CLAMP PLATE

194118 SPRING

193974 TAPE DEPRESSOR

90789 WASHER, FLAT
119650 RETAINING RING

193966 BRACKET W/STUD

193968 POST
153537 SCREW
2191 LOCKWASHER

194123 SCREW W/DISK
110743 LOCKWASHER
151880 NUT

320120 POST
151880 NUT

151722 SCREW
2191 LOCKWASHER
7002 FLAT WASHER

151632 OR
151442 SCREW
2191 LOCKWASHER
3598 NUT

153239 ROLLER
119648 RETAINING RING

193972 EXTENSION W/STUD
194122 TAPE PLATFORM
W/GUIDE

151722 SCREW
2191 LOCKWASHER

151722 SCREW
2191 LOCKWASHER
125015 FLAT WASHER

152400 SELECTOR
MOUNTING PLATE

RETAIN IF PRESENT
OR USE

151632 SCREW
2191 LOCKWASHER

3598 NUT
2191 LOCKWASHER
156472 SPRING POST

FIGURE 2

50247S

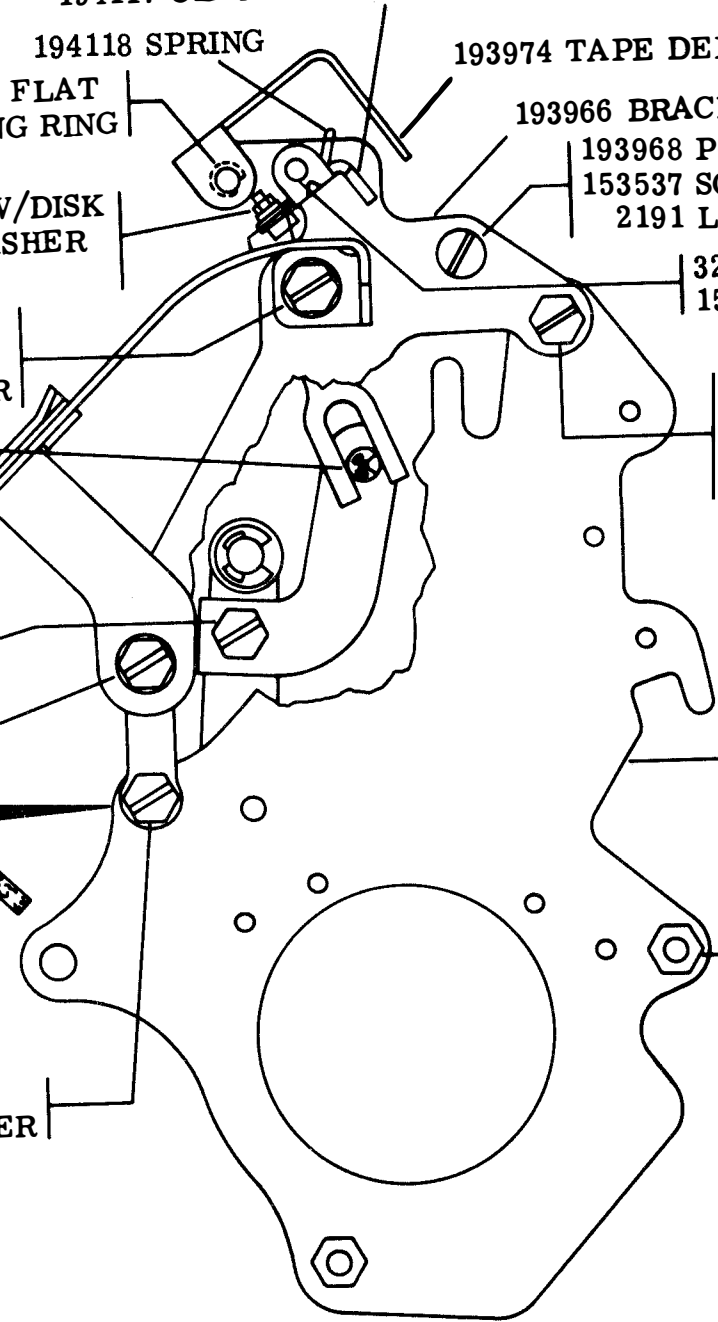

50247S

SLACK TAPE MECHANISM

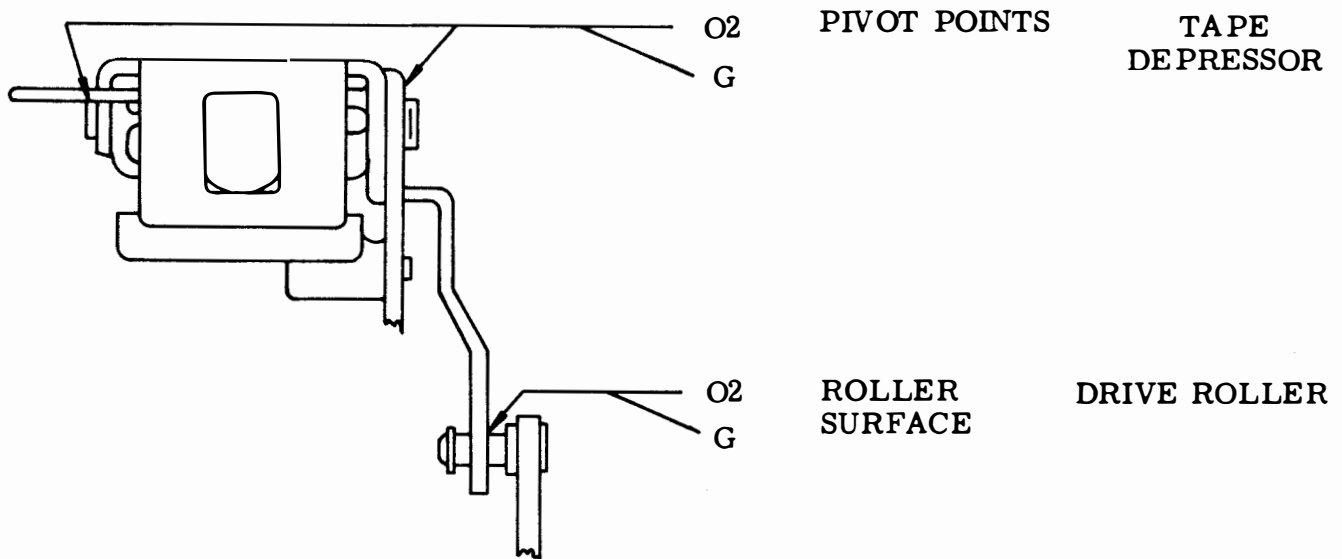
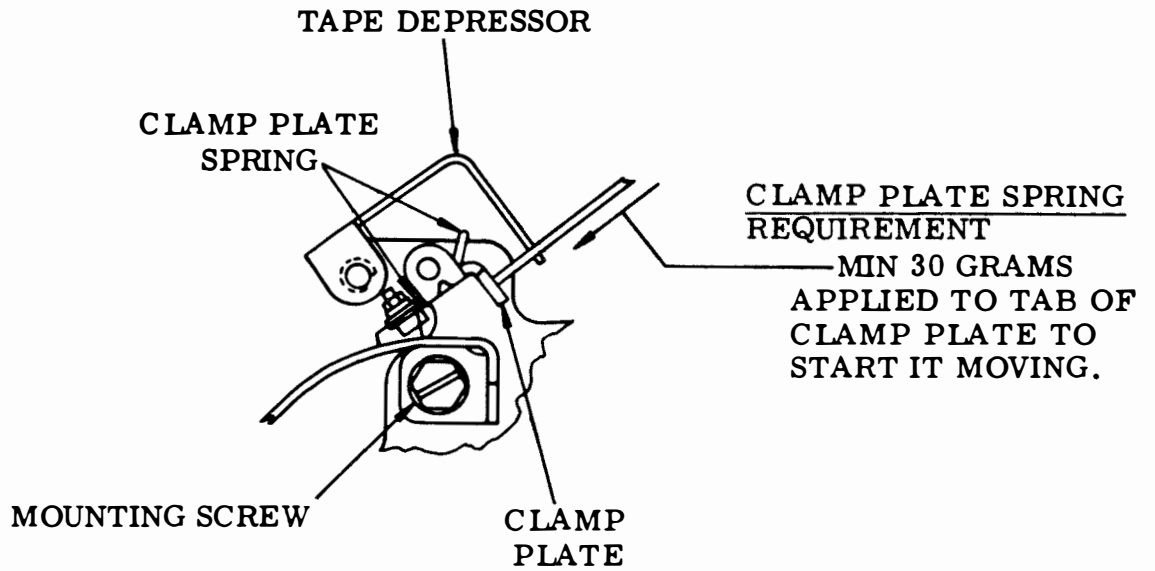
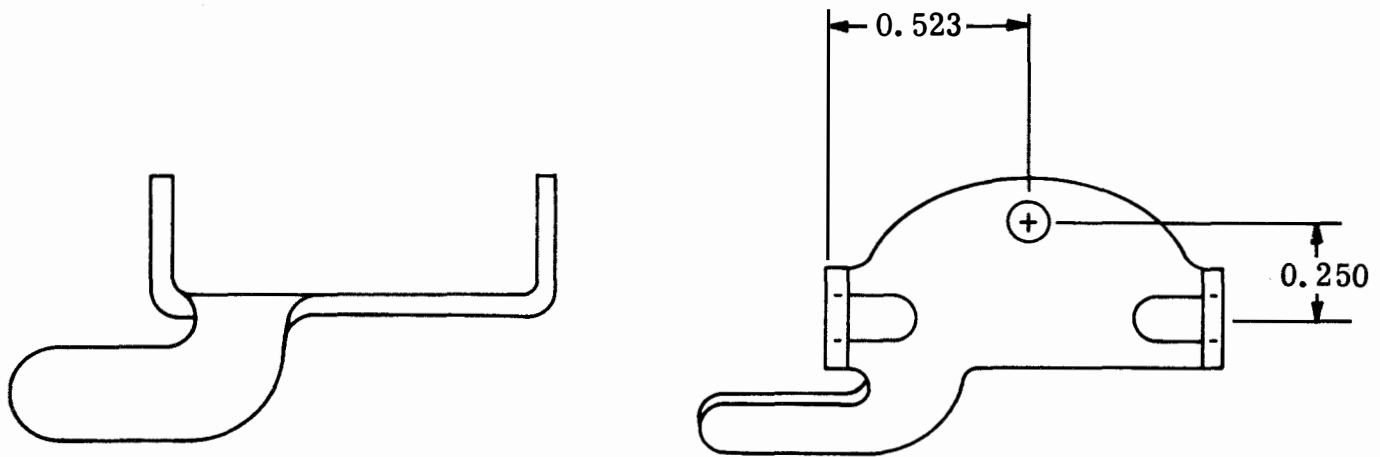
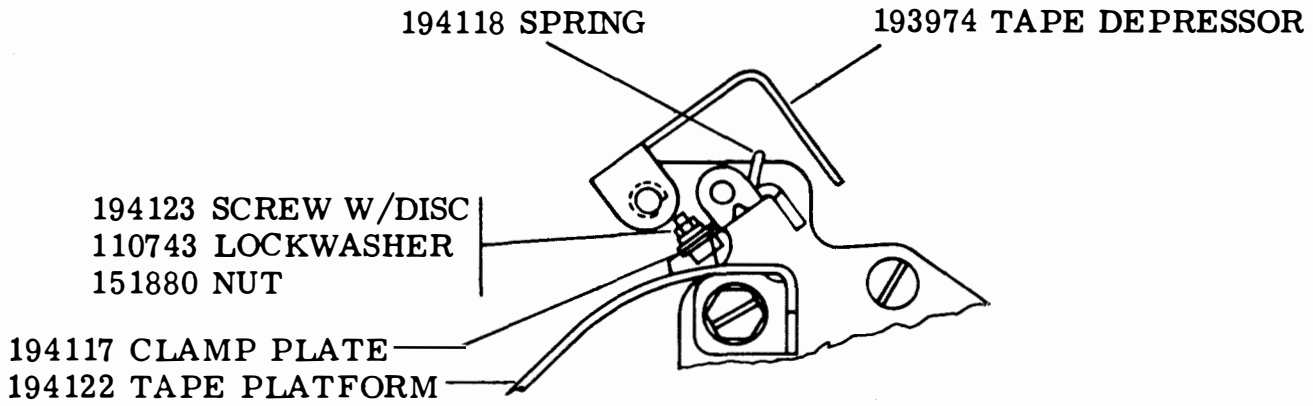

FIGURE 3

NOTE: CLAMP PLATE SCREW W/DISC ADJUSTMENT - LOOSEN NUT AND TURN SCREW W/DISC SO THAT A NEW AREA OF THE DISC CONTACTS THE TAPE. THIS ADJUSTMENT SHALL BE MADE ONCE EVERY LUBRICATION PERIOD OR WHEN THE TEN HOLES PER INCH REQUIREMENT IS NOT BEING HELD.



NEW-STYLE

194117 CLAMP PLATE

NOTE: ALL DIMENSIONS IN INCHES

FIGURE 4