

ADDENDUM TO SPECIFICATION 502045, ISSUE 2, DATED
SEPTEMBER, 1964 COVERING THE 195415 MODIFICATION KIT

1. SPECIFIC

Make the following changes in the Specification:

a. On Page 1 in Paragraph 1.e. change the description of part 159287 to isolator ✓
Page 2, 1.e. ✓

4 34432 Washer ✓ Flat was changed to (2)34432 Washer, Flat.

5 125009 Nut was deleted. ✓

3 112626 Nut was added. ✓

1 304229 Plate was added. ✓

b. Starting on Page 2 replace the entire Section 2 - 2. INSTALLATION with the following:

2. INSTALLATION

a. Remove Printer (LP) and Motor Unit (LMU) and remove the keyboard or base from cabinet.

b. Remove from the keyboard and discard the following items:

(1) Intermediate gear assembly and associated mounting facilities. Save one of the two 151712 pivot buttons.

(2) Connector and motor terminal block mounting bracket. Retain the connector, terminal block, and all associated mounting hardware.

(3) If this modification kit is to be installed on a Model 28 Keyboard or Base, discard the two 121414 posts.

c. Insert two 198680 clamping screws through the 198679 bracket. (Refer to Figure 2). Secure bracket to base (raised extension toward rear) using the furnished 44035 screws, 2669 lockwashers and 304229 plate. (Remove the oil drip pan on the upper or middle shelves of an LBAC Apparatus Cabinet). Use the slots in the base at the rear of the keyboard vacated by the intermediate gear assembly. Position bracket at forward edge of slots (toward printer) and tighten the 44035 screws.

d. Assemble the 145366 gear to the input shaft of the assembly with one 151658 screw and one 2191 lockwasher. Place gear bracket assembly over clamping screws. Assemble remaining 198680 clamping screw and associated hardware through the remaining slot vacated by the intermediate gear assembly. Assemble two 145393 bushings and associated hardware into gear bracket assembly.

(a) When operating with a 50 cycle motor replace 145366 Gear with 318901 Gear. (Part of Gear Set 318904).

e. Position 151245 felt washer on 145386 sleeve assembly. See Figure 1.

f. Insert 145383 key into keyway of 195417 shaft with 145385 spring and 145384 pin in place. Hold spring depressed. See Figure 1.

NOTE

The above parts are assembled at the factory. The instructions are for reference only.

g. With the left end of the 145383 key extending beyond the left end of the 195417 shaft, position the extension of the left end of the key, in the hole on the inner bearing surface of the sleeve assembly and slide the sleeve assembly onto the 195417 shaft. Care must be taken that the spring and pin at the right end of the key remain in alignment as the key slides into the bearing in the 195158 bracket. The 145386 sleeve assembly should be assembled on the 195417 shaft with the 151245 felt washer nearest the 195158 bracket casting.

h. Assemble the 195167 lever to the 195163 bracket. (See Figure 2.) Assemble the 195163 bracket to the gear shift casting. Fasten the lower end of the 195167 lever to the 145386 collar.

j. Mount the connector to the 195168 bracket using retained hardware and following reverse of removal procedure.

k. Fasten the 195168 bracket and 195169 terminal block bracket to the bracket mounted to the gear shift casting. Place the 195169 bracket between the 195168 bracket and the gear shift bracket. Use two each 151630 screw and 2191 lockwasher. See Figure 3.

l. Fasten the motor terminal block to the 195169 bracket using retained hardware.

(1) On the top or middle shelf of an LBAC Apparatus Cabinet, the two 121414 posts are mounted in place of the 151415 terminal block, the two 151335 posts, and the two 150966 insulators. See Figure 5.

m. Fasten the 145365 motor pinion to the motor with a 159287 isolator and two 161301 posts.

(a) When operating with a 50 cycle motor replace 145365 Motor Pinion with 318900 Motor Pinion. (Part of Gear Set 318904).

n. If a time delay mechanism is to be used, insert the 195420 pawl into the gear bracket assembly. The open end of the pawl fits on the eccentric hub of the 195418 gear as shown in Figure 4.

o. Adjust and lubricate in accordance with this adjustment and lubrication section of this specification. Replace the oil drip pan removed in Paragraph c.

p. Mount 149881 cover on top of terminal block as shown in Figure 4. Replace the original screws in the 151335 posts with two 151631 screws. Add two 7002 flat washers.

(1) On the top or middle shelf of an LBAC Apparatus Cabinet, the 149881 cover is mounted on top of the two 121414 posts using the two 151631 screws, two 7002 flat washers and two 2191 lockwashers. See Figure 5.

q. If the 195415 modification kit is to be mounted in LBAC227, 233, 235, or 247 Apparatus Cabinets, refer to Specification 50209S for the 195921 and 195922 modification kits to equip Model 28 Apparatus Cabinets with paper winders if paper winders are used.

NOTES

To service this mechanism it is not necessary to remove the keyboard from the cabinet. Remove printer, motor unit, and 149881 cover. Follow procedure in Paragraph b. for re-assembly.

Upon completion of installation and adjustment of this modification kit it should be shifted through its three speed selections while the motor is running to assure interference free operation of the shift linkage. If 7.42 unit code, 45.5, 50 and 75 baud transmission lines are available, it is suggested that the printer associated with this shift could be connected to these signal lines to check proper speed of operation. If a time delay mechanism is used with this kit it should be checked to assure proper operation.

c. On Figure 4 delete the 150966 insulators, delete 151415 terminal block, and change the 151335 post to the 121414 post.

Page 4, 3. b. (1) changed to read:

- (1) Requirement - There should be a barely perceptible amount of backlash between the motor pinion and its driving gear and between the speed shift gear bracket assembly idler and its driven gear on the printer (LP).

The 195415 Modification Kit is for use with a 60 cycle 3600 R.P.M. motor. If it is to be used with a 50 cycle 3000 R.P.M. motor, Gear Set 318904 is available to provide operation of the 195415 Modification Kit with a 50 cycle 3000 R.P.M. motor. This gear set is not supplied with the modification kit but may be obtained separately.

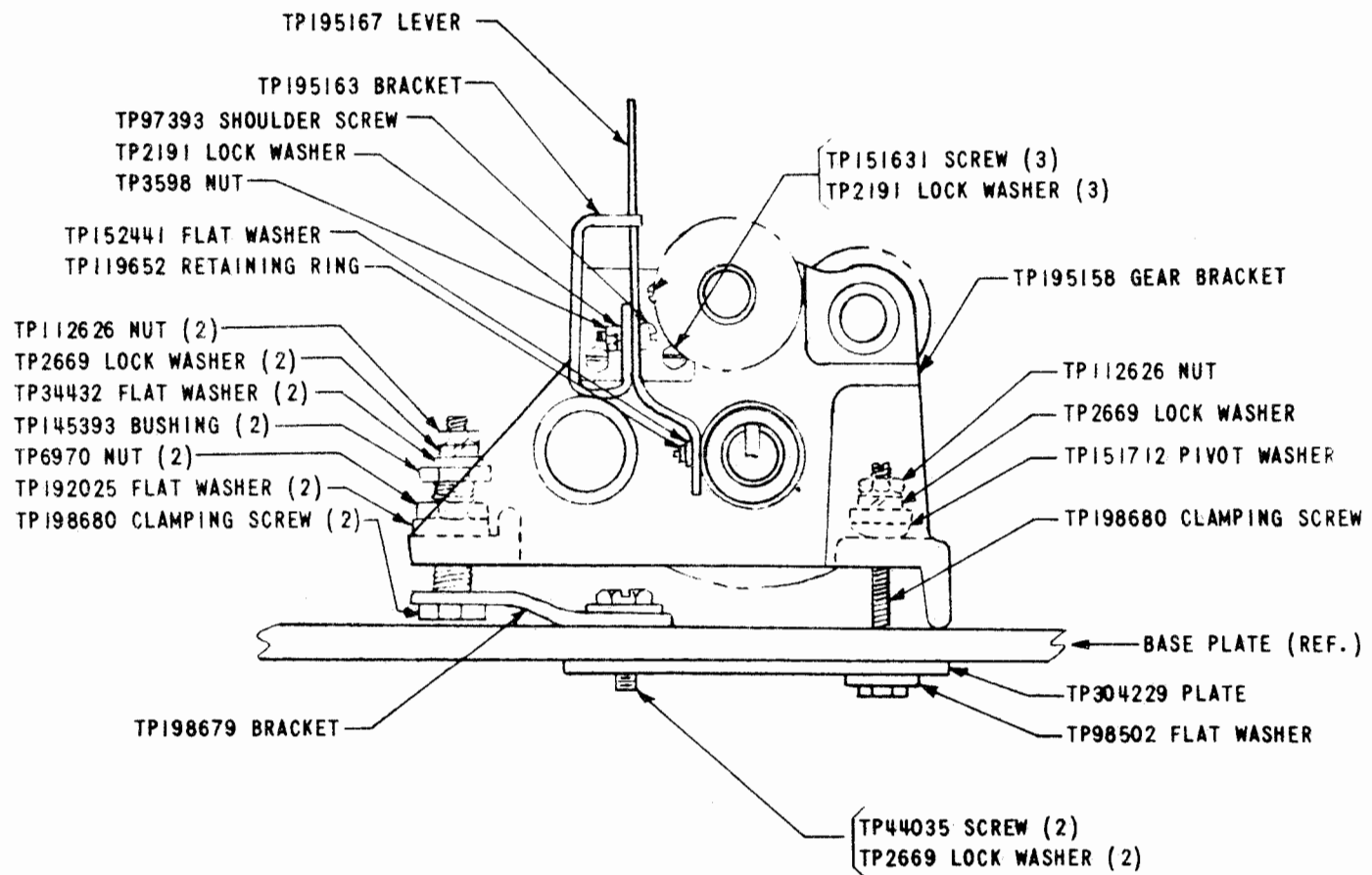

FIGURE 2 (50204S)

INSTRUCTIONS FOR INSTALLING THE 195415 MODIFICATION
KIT TO PROVIDE A THREE SPEED GEAR SHIFT FOR MODEL 28
KSR OR RO SET

The chart below pertains to the U.S. Navy only

TELETYPE NUMBER	NAVY NUMBER	FEDERAL STOCK NUMBER
195415	MK-810/UG	5815-051-3824
The modification kit is for use with Navy Teletypewriter Sets TT-47/UG and TT-69/UG. This is Field Change 6 to TT-47/UG and TT-69/UG.		

1. GENERAL

- a. The 195415 modification kit provides a Model 28 KSR or RO with a three speed gear shift. The kit is mounted on a keyboard or base in place of the intermediate gear assembly. Shifting is done by a lever mounted on the left side of the gear shift.
- b. The 195415 modification kit provides a three speed gear shift to operate a Model 28 Page Printer (LP) and Keyboard (LK) at 45.5, 50 and 74.2 baud, 7.42 unit code (60, 67, 100 wpm). The manual movement of the shift lever operates the gear shift. Speed selections can be made while the motor is running but it is necessary to open the cabinet to reach the shift lever.
- c. When the 195415 modification kit is to be installed on a keyboard which is equipped with either 152916 or 154145 local reverse line feed modification kit two of the local reverse line feed parts must be replaced. These replacement parts are not supplied with the 195415 modification kit but should be ordered as modification kit 149896.
- d. The 195415 modification kit is not compatible with an LD mounted on the keyboard or base, the 164848 modification kit to provide parallel output contacts, or with the 163146 modification kit to provide universal contact on a printer. It is also incompatible with the wall mounted printer.
- e. The 195415 modification kit consists of:
- | | | | | | |
|---|------|--------------|---|--------|---------------------------|
| 7 | 2191 | Lockwasher | 5 | 151631 | Screw |
| 5 | 2669 | Lockwasher | 1 | 151658 | Screw |
| 1 | 3598 | Nut | 1 | 152441 | Washer, Flat |
| 2 | 6970 | Nut | 1 | 159287 | Retainer, Pinion ISOLATOR |
| 2 | 7002 | Washer, Flat | 2 | 161301 | Post |

2	34432	Washer, Flat	1	304229	PLATE
2	44035	Screw	2	192025	Washer, Flat
1	97393	Screw, Shoulder	1	195163	Bracket
1	98502	Washer, Flat	1	195167	Lever
1	119652	Ring, Retaining	1	195168	Bracket
5	125009	Nut	1	195169	Bracket
1	145365	Gear, Helical	1	195170	Gear Bracket Assembly, Speed Shift
1	145366	Gear w/Insert	1	195420	Pawl
2	145393	Bushing	1	198679	Bracket, Bolt Retaining
1	149881	Cover, Gear	3	198680	Screw, Clamping
2	151630	Screw	1	305664	Plate, Instruction
			3	112620	NUT

e. For parts ordering information see Teletype Parts Bulletin 1149B. (U.S. Navy see Navships 93241).

2. INSTALLATION

a. Remove Printer (LP) and Motor Unit (LMU) and remove the keyboard or base from cabinet.

b. Remove from the keyboard and discard the following items:

(1) Intermediate gear assembly and associated mounting facilities. Save one of the two 151712 pivot buttons.

(2) Connector and motor terminal block mounting bracket. Retain all connector and terminal block mounting hardware.

(3) Motor pinion.

c. Insert two 198680 clamping screws through the 198679 bracket. (See Figure 2.) Fasten the bracket to the top of the keyboard or base. Place the bracket mounting screws through the slots at the rear of the keyboard or base, vacated by the intermediate gear assembly. Position bracket at forward edge of slots, toward the printer, and tighten.

d. Place 195170 gear bracket assembly over clamping screws. Assemble remaining 198680 clamping screw and associated hardware through the remaining slot vacated by the intermediate gear assembly. Assemble two 145393 bushings and associated hardware into 195170 gear bracket assembly. Assemble 145366 gear to gear bracket with one 151658 screw and one 2191 lockwasher.

e. Position 151245 felt washer on 145386 sleeve assembly. See Figure 1.

f. Insert 145383 key into keyway of 195417 shaft with 145385 spring and 145384 pin in place. Hold 145385 spring depressed. See Figure 1.

NOTE

The parts in f. above are assembled at the factory. Instructions for reference only.

- g. With the left end of the 145383 key extending beyond the left end of the 195417 shaft, position the extension of the left end of the key, in the hole on the inner bearing surface of the sleeve assembly and slide the sleeve assembly onto the 195417 shaft. Care must be taken that the spring and pin at the right end of the key remain in alignment as the key slides into the bearing in the 195158 bracket. The 145386 sleeve assembly should be assembled on the 195417 shaft with the 151245 felt washer nearest the 195158 bracket casting.
- h. Assemble the 195167 lever to the 195163 bracket. (See Figure 2.) Assemble the 195163 bracket to the gear shift casting. Fasten the lower end of the 195167 lever to the 145386 collar.
- i. Mount the connector to the 195168 bracket using retained hardware and following reverse of removal procedure.
- j. Fasten the 195168 bracket and 195169 terminal block bracket to the bracket mounted to the gear shift casting. Place the 195169 bracket between the 195168 bracket and the gear shift bracket. Use two each 151630 screw and 2191 lockwasher. See Figure 3.
- k. Fasten the motor terminal block to the 195169 bracket using retained hardware.
- l. Fasten the 145365 motor pinion to the motor with a 159287 retainer and two 161301 posts.
- m. When a time delay mechanism is to be used, insert the 195420 pawl into the gear bracket assembly. The open end of the pawl fits on the eccentric hub of the 195418 gear as shown in Figure 4. Discard the pawl and eccentric supplied with the time delay mechanism.
- n. Mount 149881 cover on top of terminal block as shown in Figure 4. Replace the original screws in the 151335 posts with two 151631 screws. Add two 7002 flat washers.
- o. Replace keyboard or base in cabinet and install Printer (LP) and Motor Unit (LMI) in accordance with standard practice.

NOTES

Upon completion of installation and adjustments of this modification kit it should be shifted through its three speed selections while the motor is running to assure interference free operation of the shift linkage. When 7.42 unit code, 45.5, 50, and 74.2 baud transmission lines are available the printer associated with this gear shift should be connected to these signal lines to check proper speed of operation. When a time delay mechanism is used with this kit it should be checked to assure proper operation. Affix the 305664 plate near the Nomenclature Nameplate of the Set.

3. ADJUSTMENT AND LUBRICATION

a. For standard adjustments and lubrication procedure refer to Teletype Model 28 Bulletin 217B. (U.S. Navy refer to T-7 to Navships 93241).

b. Gear shift assembly adjustment to driven gear, motor pinion and time delay mechanism. (Refer to Figure 2).

(1) Requirement - There should be ^{BARELY PERCEPTIBLE} ~~.004 to .008~~ inch backlash between the motor pinion and its driven gear and between the speed shift gear bracket assembly idler and its driven gear on the Printer (LP).

(2) Requirement - The 195420 pawl should be positioned relative to the associated parts of the time delay mechanism so that it rides freely without binding on the 195418 gear and eccentric.

(3) Requirement - There should be some clearance between the motor end bell and the 145366 gear shift input gear.

To Adjust - Loosen the three screws which mount the speed shift gear assembly and loosen the two lock nuts which lock the adjusting bushings at the rear of the assembly. Position the assembly and adjust the height at the rear by means of the adjusting bushing nearest to the motor. The other bushing should be backed out for clearance. After correct adjustment has been obtained, lock the adjusting bushing nut. Turn the other bushing with the fingers until it touches the base and tighten the lock nut. Tighten all mounting screws and recheck requirements.

c. Shift Lever Bracket Adjustment (Refer to Figure 3).

(1) Requirement - The 195167 shift lever should be positioned within the detent notches in the 195163 bracket.

To Adjust - Loosen the three 151631 screws which mount the 195163 bracket and reposition the bracket. Tighten the mounting screws.

d. Terminal Block Mounting Bracket Adjustment (Refer to Figures 3 and 4)

(1) Requirement - There should be a .062 minimum clearance between the 195169 terminal block mounting bracket and each of the three gears below the bracket.

(2) Requirement - The formed tab on the 149881 cover should rest securely on the gear bracket so as to prevent rattling.

To Adjust - Loosen the two 151630 screws which mount the 195169 bracket to the 195163 shift bracket. Raise or lower the free end of the 195169 bracket and tighten the mounting screws.

e. Key Spring

(1) Requirement - It requires 25 to 40 ounces applied above the spring to depress the key to its lowermost position in the slot.

To Adjust - To measure, disconnect the operating linkage by removing the retaining ring and moving the operating end of the key out from under the gears. Use care to avoid loss of pin and spring.

f. Lubrication

(1) Use Teletype KS7471 grease on the periphery of all gears.

(2) Use Teletype KS7470 oil on the following:

(a) One or two drops on both pivot points of shift lever.

(b) Saturate all felt washers.

(c) One or two drops on bronze casting bearings.

(d) A light coat on the flanged sleeve and bearing, key, and spring.

(e) One or two drops on the eccentric bearing and surface of the eccentric follower pawl.

*

*

*

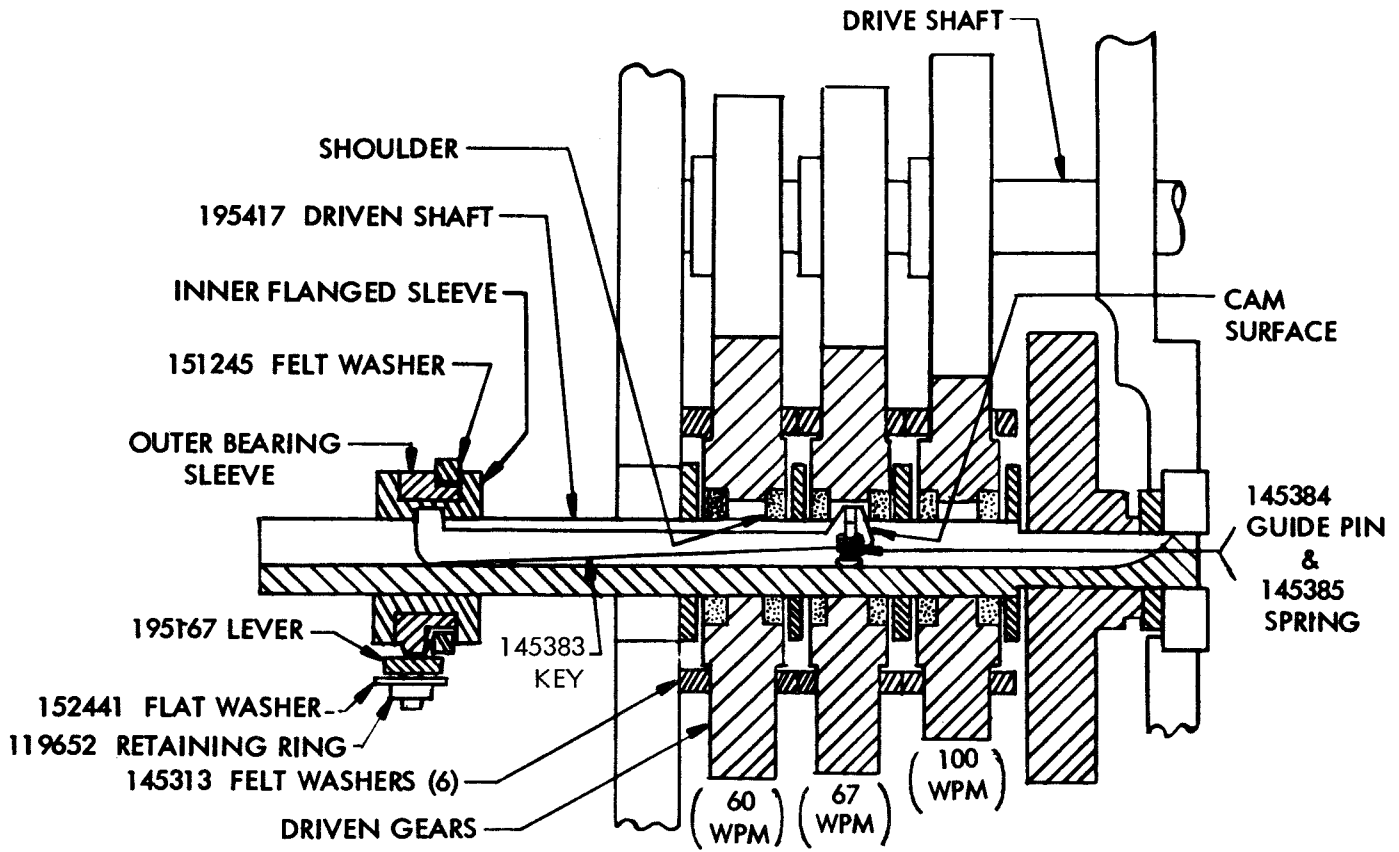

OPERATION OF SPEED SHIFT GEAR BRACKET ASSEMBLY AND ASSOCIATED PARTS

NOT TO SCALE

FIGURE 1

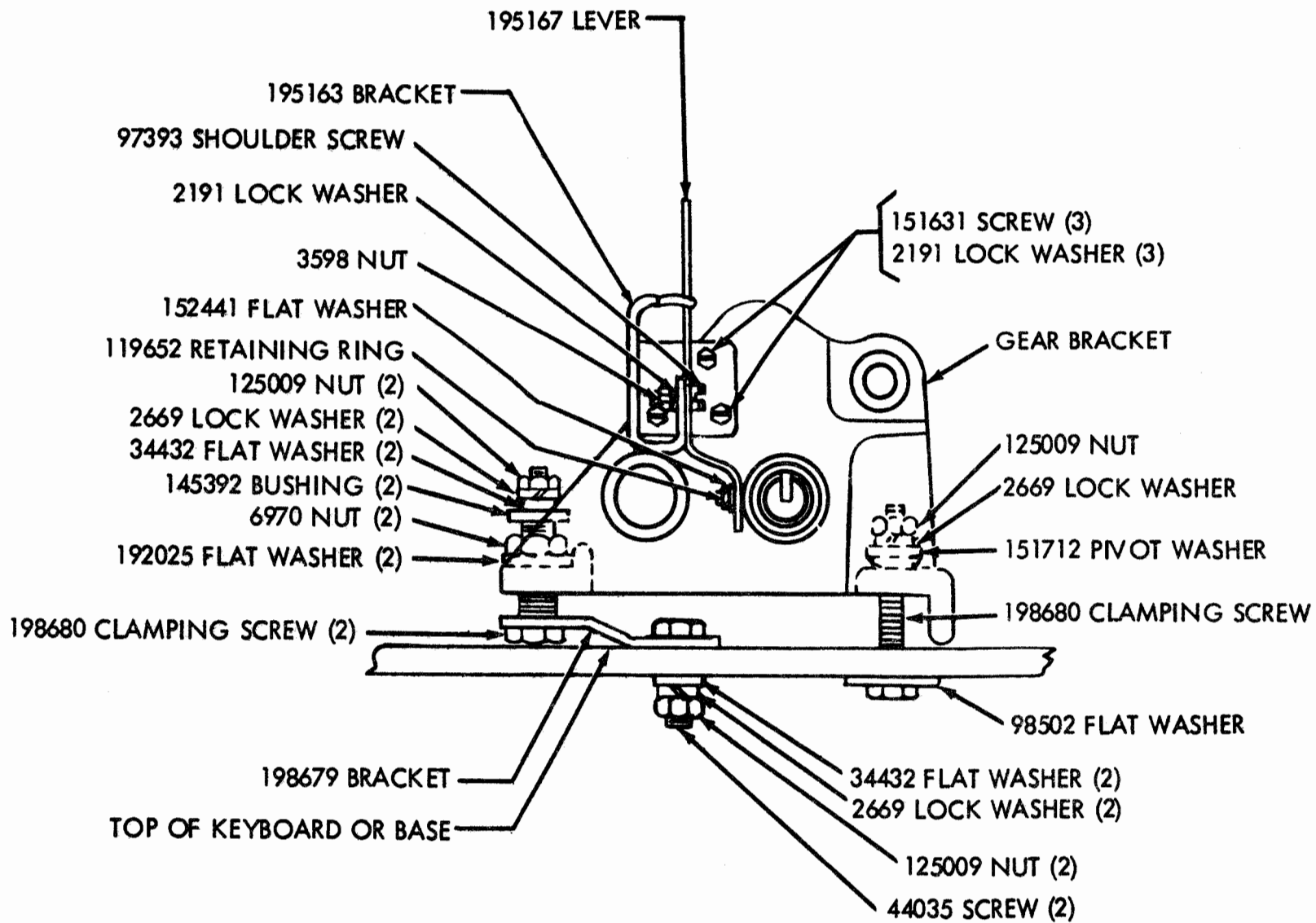

FIGURE 2

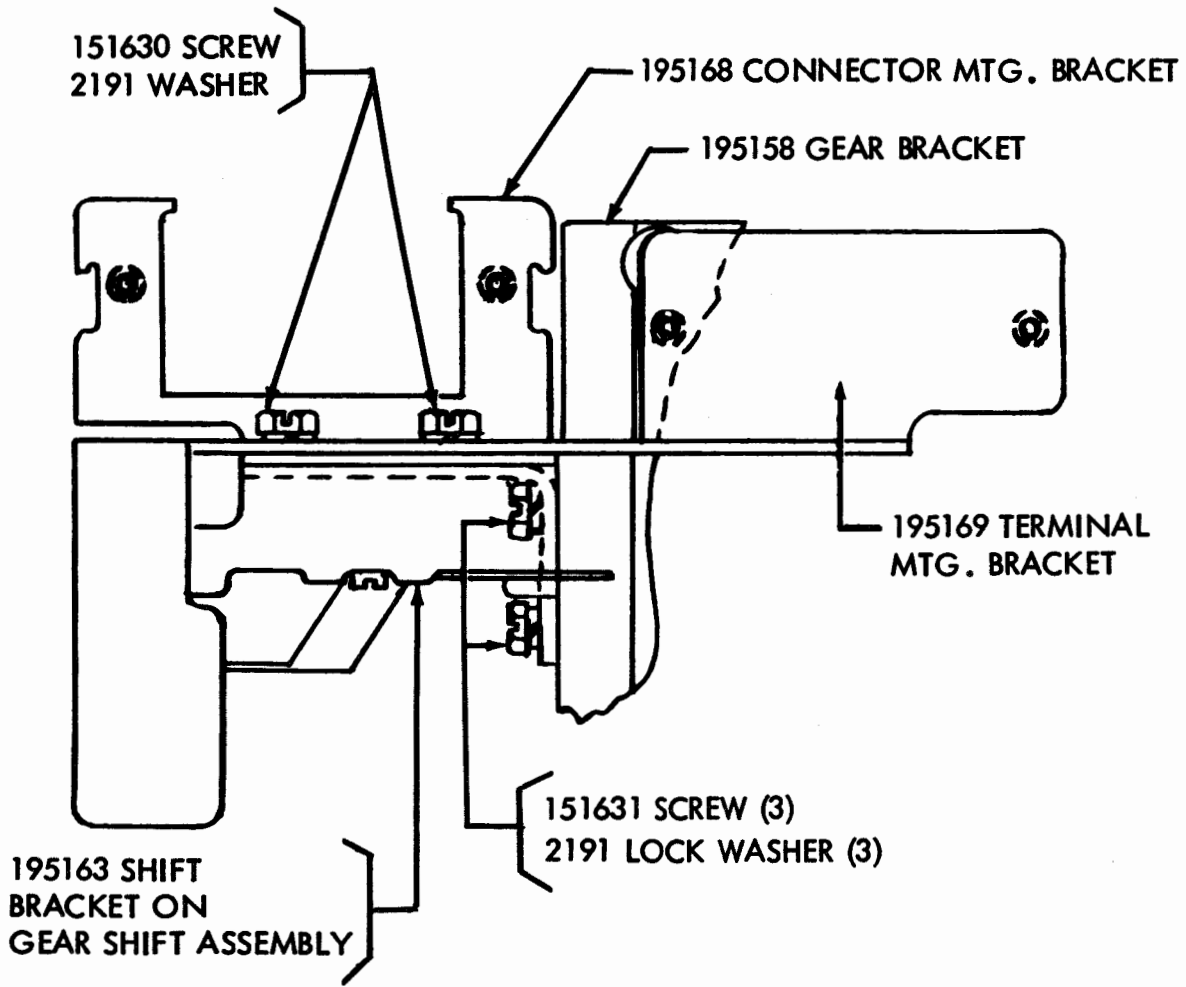
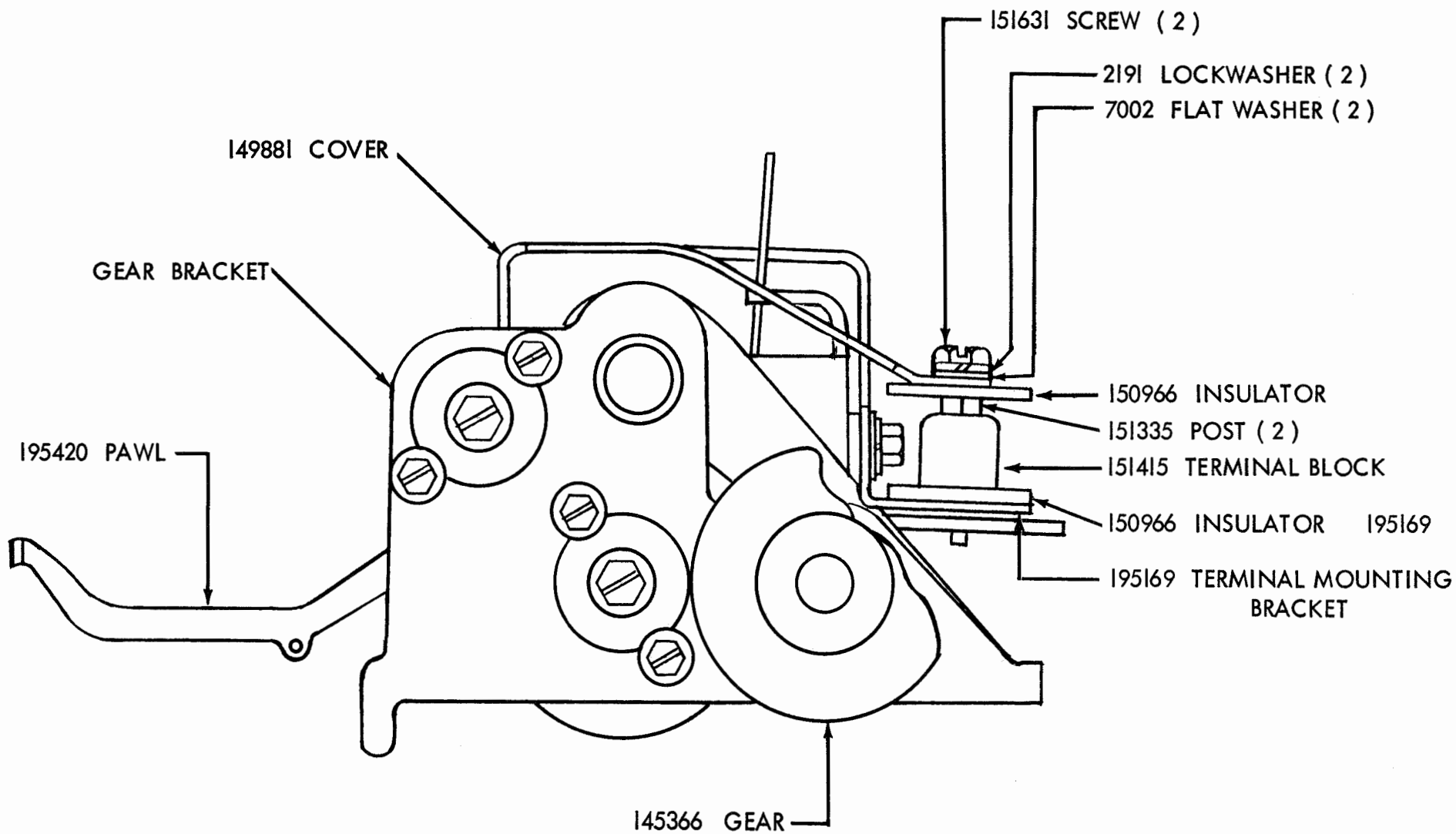

FIGURE 3



502045

FIGURE 4