

INSTRUCTIONS FOR INSTALLING AND ADJUSTING THE 174285
MODIFICATION KIT TO CONVERT A MODEL 28 TYPING REPER-
FORATOR UNIT (LPR) INTO A TAPE PRINTER UNIT (LTP)

The following chart pertains to Bell System only:

Teletype Unit	Teletype Code	Bell System Code
Typing Reperforator	LPR	28A through 28G, 28J through 28M
Tape Printer	LTP	28LA, 28LA-1

Refer to standardized information for Adjustments and Lubrication.

1. GENERAL

a. The purpose of the 174285 Modification Kit is to convert a Model 28 Typing Reperforator Unit (LPR) into a Tape Printer Unit (LTP).

b. The tape printer unit may be used with the typing reperforator single-plate or double-plate base in conjunction with a tape reel (included in the kit) to accommodate the 3/8 inch tape.

c. The 174285 Modification Kit consists of:

1	3599	Nut	1	144797	Shaft w/Knob, Feed Wheel
1	8330	Washer, Flat	2	144998	Post
1	94669	Screw, Shoulder	1	144999	Shoe, Tape
1	94712	Washer, Flat	1	145333	Disk w/Hub
1	110743	Washer, Lock	1	145335	Disk w/Nut
3	119652	Ring, Retainer	1	145353	Wheel, Pressure
1	144793	Shaft w/Ring Eccentric	1	145356	Wheel, Feed
1	144794	Spring, Torsion	1	145357	Guide, Tape
1	144795	Plate, Rear	1	145358	Bracket, Tape Guide
1	144796	Plate, Front	1	170241	Screw, Adjusting

2. INSTALLATION (Figures 1, 2 and 3)

NOTE

For parts referred to other than those included in the modification kit, refer to Teletype Model 28 Typing Reperforator Parts Bulletin 1167B.

a. Disassembly

- (1) Remove the typing reperforator from its base in accordance with standard practice.
- (2) Remove the typewheel by removing the 3598 Nut, 2191 Lock Washer, and 7002 Flat Washer. Retain the typewheel, lock washer, flat washer, and nut. Discard the 156390 Washer from behind the typewheel.
- (3) Remove the perforator assembly from the reperforator unit.
- (4) Remove the punch block assembly by removing the four 152893 Screws and 110743 Lock Washers. Disconnect and discard the four 55063 Springs. Discard the punch block assembly. Retain the mounting hardware.
- (5) Remove the 156040 Post which holds the right leg of 156036 Tape Guide, 119652 Retainer and 5363 Spring by removing the 151630 Screw and 2191 Lock Washer from the front and the 152893 Screw and 110743 Lock Washer from the rear. Discard the 156040 Post, and 5363 Spring. Retain the mounting hardware.
- (6) Remove the 156040 Post which holds the left leg of the 156036 Tape Guide, 156061 Tape Shoe Arm and 156047 Spring. Remove and discard the 119648 Shoe Pivot Retaining Ring, 156062 Shoe Pivot, 156052 Tape Shoe, 156036 Tape Guide and 156040 Post. Retain the mounting hardware, the 156061 Tape Shoe Arm and the 156047 Spring.
- (7) Remove and discard the 156046 Tape Guide Block and retain one 151637 Screw and one 110743 Lock Washer.

NOTE

If the unit is so equipped, remove and discard the 164514 Tape Guide, the 172638 Screw, 2191 Lock Washer, 7002 Flat Washer, and 159981 Spacer.

- (8) Remove the 156044 Die Wheel Stud which holds the 156055 Die Wheel by removing the 151416 Mounting Nut, 2191 Lock Washer and 7002 Flat Washer. Retain only the 93356 Felt Washer.
- (9) Remove and retain the 160948 Feed Wheel Shaft Screw and 90791 Lock Washer. Retain the 156019 Felt Washer.
- (10) Remove and retain the 1036 Adjusting Screw Lock Nut and 2191 Lock Washer which holds the 156090 Adjusting Screw. Discard the 156090 Adjusting Screw.
- (11) Place the perforator assembly on a flat surface so that it is resting on the rear plate. Remove and retain the 151630 Screw and the 2191 Lock Washer which holds the 156042 Spacing Post.

(12) Remove and retain the 161139 Nut, 2191 Lock Washer and 7002 Flat Washer which holds the 156050 Detent Lever Eccentric Stud. Unhook the two springs from the detent lever. If unit is so equipped, remove and retain automatic letters modification kit parts; (2) 119648 Retainer Rings, 151152 Screw, 110743 Lock Washer, 125011 Flat Washer, 162770 Plate, 162768 Latch.

(13) Place the assembly on the rear plate and gently lift the entire front plate mechanism from the perforator assembly being careful not to disengage the guide post. Remove the 156008 Feed Wheel, 156019 Felt Washer, and the 156050 Detent Lever Eccentric. Discard the 156008 Feed Wheel.

b. Reassembly

(1) Put the 8330 Flat Washer on the threaded end of the 156050 Detent Lever Stud and replace the stud.

(2) Install the 145356 Feed Wheel and the 156019 Felt Washer retained in setp a.(14) above. Replace front plate mechanism.

(3) Replace the 151630 Screw and 2191 Lock Washer in the 156042 Post.

(4) Secure the 144999 Tape Shoe to the 156061 Tape Shoe Arm (retained in step a.(6)) using the 94669 Shoulder Screw, 110743 Lock Washer and 3599 Nut. (See Figure 3.)

(5) Install the 145357 Tape Guide, 156047 Spring, and 156061 Tape Shoe Arm Assembly on the 144998 Posts securing with the 119652 Retaining Rings.

(6) Place the 93356 Felt Washer and the 145353 Pressure Wheel on the 144793 Eccentric Shaft Pin. Place the 144794 Torsion Spring on the post as shown in Figure 3.

(7) Install the 170241 Adjusting Screw using hardware retained in step a.(10).

(8) Secure the 144796 Front Plate and 144795 Rear Plate together using the parts in steps b.(5) and b.(6). (See Figures 2 and 3).

(9) Secure the plates and posts with two 151630 Screws and 2191 Lock Washers (for the front) and two 152893 Screws, one 151637 Screw and 110743 Lock Washers (for the rear). This hardware was retained in step a.(5), (6) and (7) above. Also, install parts removed in Paragraph 2.a.(12).

(10) Install the 144797 Feed Wheel Shaft using the 160948 Screw and 90791 Lock Washer retained in step a.(9) above.

(11) Mount the 145358 Tape Guide in place of the punch block assembly using the hardware retained in step a.(4) above.

(12) If the Model 28 LTP Printer is used on a Model 28 Typing Reperforator Single or Double Plate Base, a tape reel will have to be used to accommodate the 3/8 inch tape. This tape reel consists of a 145333 Disc W/Hub and a 145335 Disc W/Nut.

- (13) Remount the perforator mechanism in accordance with standard practice.
- (14) Replace the reperfocator on the base in accordance with standard practice.
- (15) Replace the typewheel using the 94712 Washer in place of the 156390 Washer and the hardware retained in step a.(2) above.

3. ADJUSTMENTS

a. Feed Wheel (Preliminary) - There should be .085 to .095 inch clearance between the feed wheel ratchet and the front plate. To adjust, turn the adjusting screw with its lock nut loosened. Tighten the nut friction tight.

b. Feed Wheel (Final) - The printing should be centrally located on the tape as gauged by eye. Any foreign printing that may occur along the upper edge of the tape is permissible. To adjust, refine the "preliminary" adjustment in Paragraph 3.a. Tighten the nut.

c. Detent Lever Eccentric - With the function clutch disengaged and the detent roller in contact with the ratchet wheel, the feed pawl should engage, with no perceptible clearance, the first tooth below a horizontal centerline through the ratchet wheel. To adjust, rotate the detent lever eccentric with its lock nut loosened. Tighten the nut.

d. Other adjustments - all other adjustments pertaining to the tape printer unit are in accordance with those for the typing reperfocator unit and are not connected in any way with the above adjustments.

4. LUBRICATION

a. Apply one drop of KS7470 oil to the following points:

144793 Eccentric Shaft, Bearing surfaces.
144794 Torsion Spring, Both ends.

NOTE

The feed wheel and pressure wheel must be free of oil.

b. Other Lubrication - All other lubrication information pertaining to the tape printer unit is in accordance with that for the typing reperfocator unit.

*

*

*

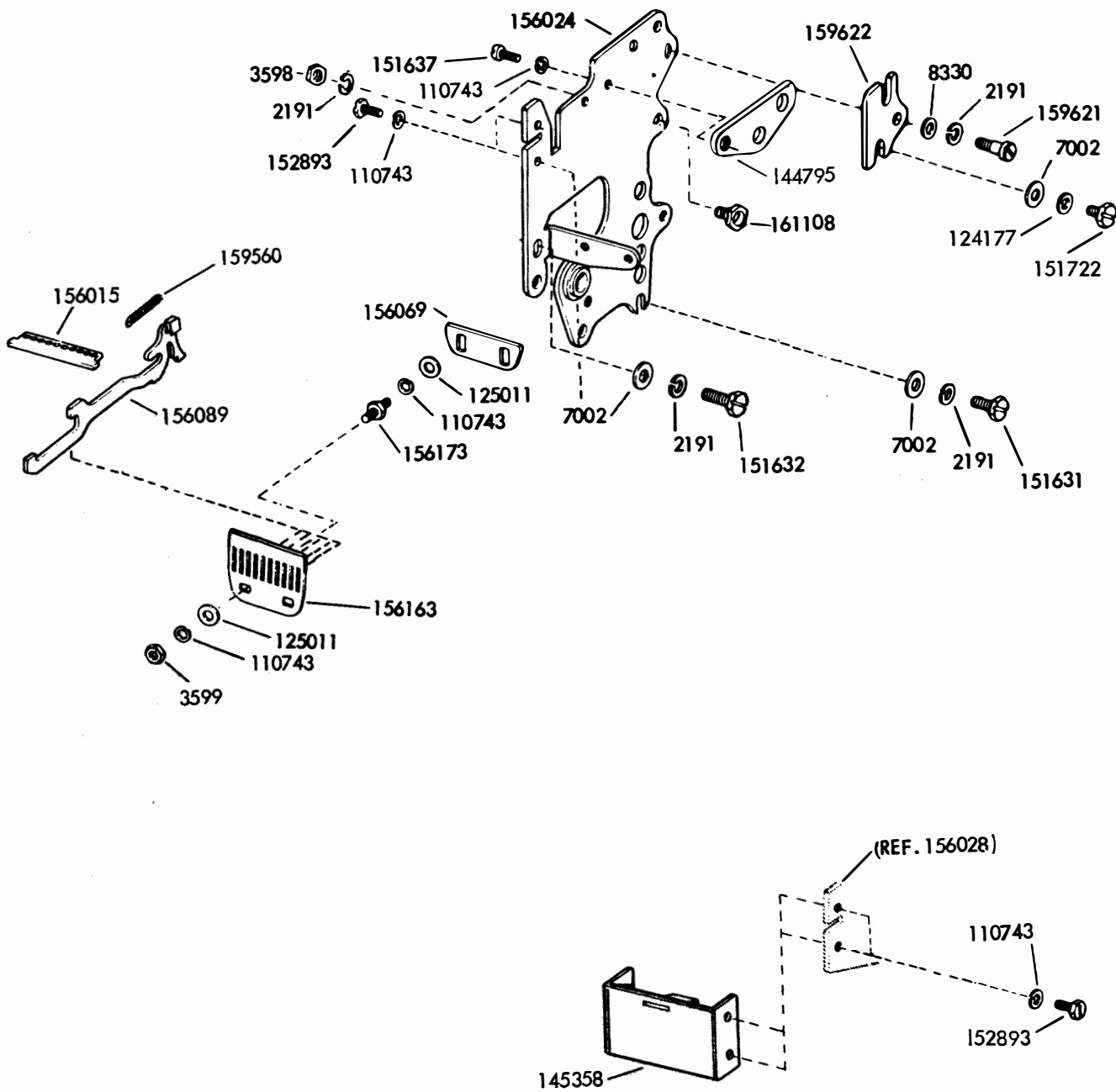

FIGURE 1.

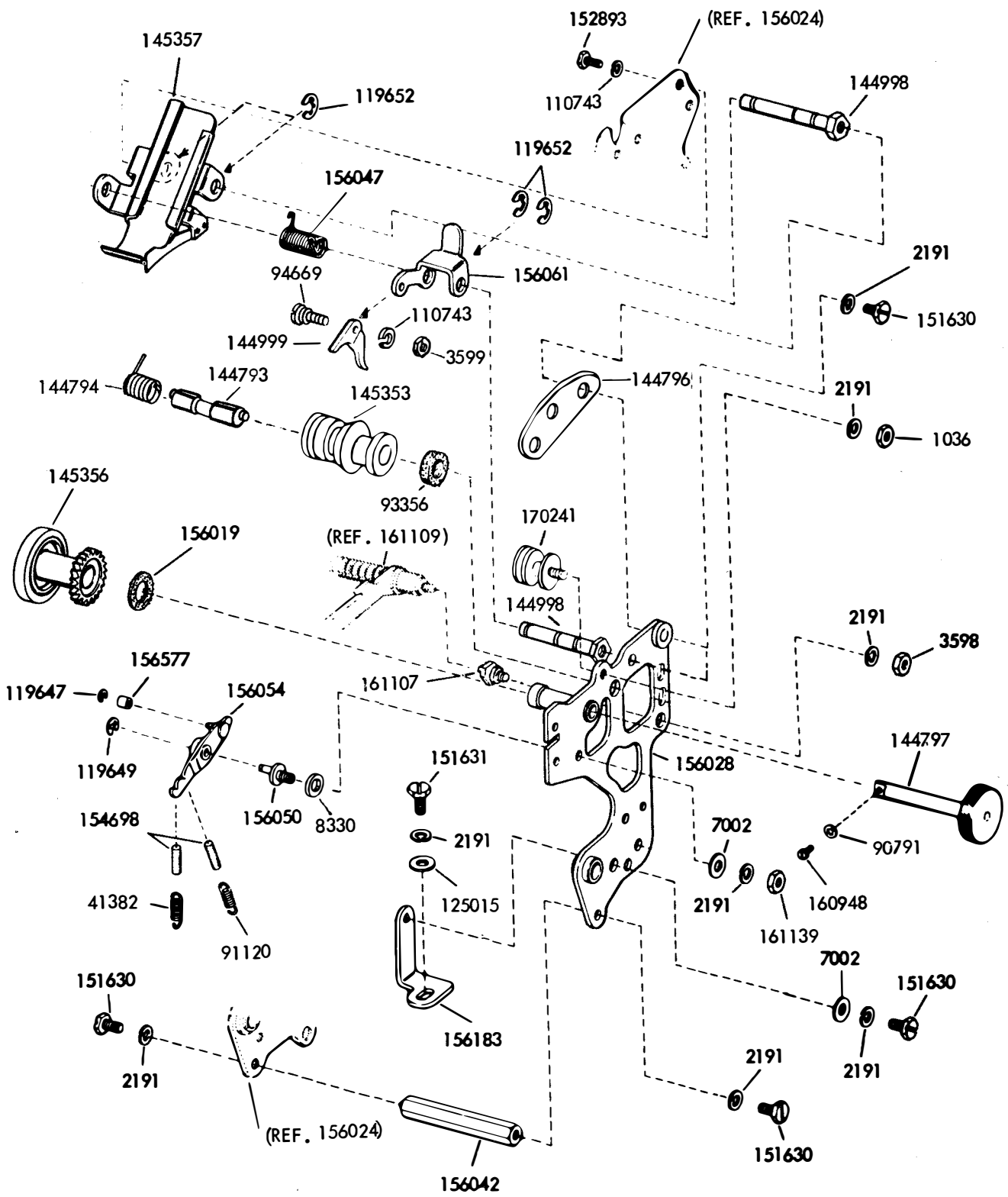

FIGURE 2.

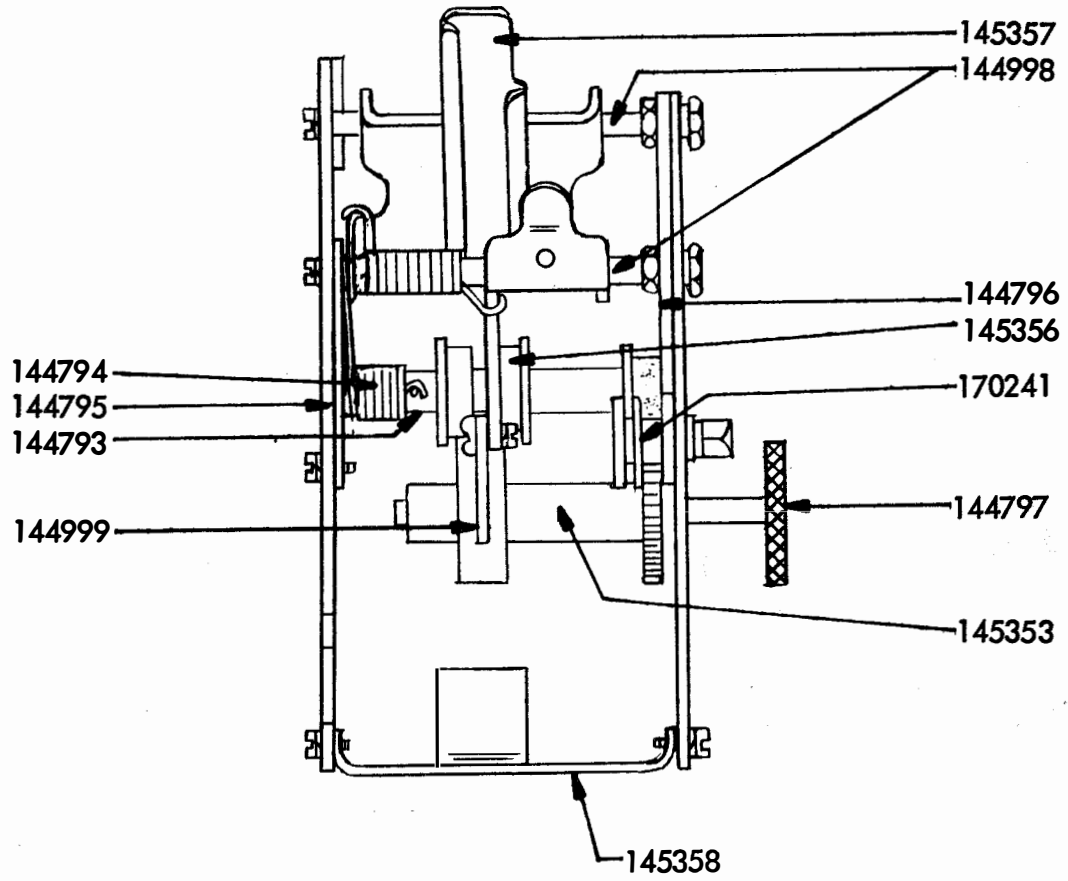

FIGURE 3.

