

INSTRUCTIONS FOR INSTALLING THE 174176 MODIFICATION  
KIT TO PROVIDE MODEL 28 SEND-RECEIVE KEYBOARD (LK6  
AND UP) WITH AN UPPER CASE "D" ANSWER-BACK MECH-  
ANISM; ALSO, KIT 176272 TO GIVE ANSWER-BACK OPERATION  
ON SEQUENTIAL "FIGURES" - "C"

1. GENERAL

- 1.01 The 174176 modification kit provides the Model 28 Send-Receive Page Printer Set (LK6 and up) with an upper case D answer-back mechanism. The kit is used on sets wired for half-duplex operation either containing or not containing an electrical service unit. The kit cannot be used with Receiving-Only (RO) Sets.
- 1.02 The 176272 modification kit is identical to the 174176 kit except that the identity of the called station is transmitted automatically on sequential Figures-C rather than upper case D.
- 1.03 The answer-back mechanism is an electromechanical device which allows the identity of the called station to be transmitted automatically to the originating station upon receipt of FIGS, upper case D from the signal line.
- 1.04 A control relay actuated by the originating station's signal generator prevents the originating station's own answer-back mechanism from operating when the distant station has been called.
- 1.05 Local answer-back may be operated from the local red HERE IS keylever.
- 1.06 The answer-back device has a total capacity of 21 characters. The first character transmitted is always a LETTERS combination; the remaining 20 may be any characters desired. However, the first LTRS combination is normally followed by CARRIAGE RETURN and LINE FEED while the coding also normally ends with CARRIAGE RETURN and LINE FEED. This arrangement insures that the answer-back message will appear at the beginning of a line on the distant station and that overprinting of the message will not occur. Transmission of the LTRS combinations at the beginning of the message also returns all stations in the circuit to the unshift position. Since five of the 21 available characters are thus used to perform these functions, only 16 are available for the answer-back identification. This procedure may be altered to suit a particular application of the answer-back mechanism.

## SPECIFICATION 50039S

- 1.07 Since the keyboard is not locked when the answer-back mechanism is triggered, a station may accidentally interfere with its operation by holding its calling keylever depressed or by depressing any keylever during the operation of the answer-back mechanism. The station must not depress any keylevers during the answer-back operation.
- 1.08 The trip magnet circuit of the answer-back mechanism is connected to the ac supply circuit of the keyboard and is operable from an input voltage of 115 volts  $+10\%$  ac, 50 to 60 hertz. The operating current is approximately 0.065 amperes ac. The answer-back mechanism operates on ac current.
- 1.09 The control relay is also connected to the ac supply circuit of the keyboard and is operable from an input voltage of 115 volts  $+10\%$  ac, 50 to 60 hertz. The operating current is approximately 0.035 amperes ac.

## 2. THEORY OF OPERATION

### Called Station

- 2.01 The answer-back message is initiated at the called station by depressing the FIGS, upper case D combination at the originating station. This action closes a normally open function box contact (upper case D) which completes a circuit to the answer-back trip magnet.
- 2.02 The closure of this circuit energizes the answer-back trip magnet and results in the counterclockwise rotation of the armature and associated stop lever latch thereby unblocking and releasing the stop lever. Under the bias of a spring attached to the codebar bail latch operating lever, which rests on the left extension of the stop lever, the stop lever rotates counterclockwise until it comes to rest against the mechanism base plate. Before coming to rest, the stop lever moves the blocking lever counterclockwise, thereby unblocking the drive plate and releasing it to its spring action. The drive plate rotates counterclockwise to a stop where the attached drive link is in a position to accept the feeding motion from the keyboard codebar bail. As the stop lever continues its counterclockwise rotation, the codebar bail latch operating lever rotates clockwise, striking the codebar bail latch. The latch rotates clockwise and releases the codebar bail. The codebar bail releases the keyboard codebars and the clutch tripbar which move to the right under spring action. The clutch tripbar thereby trips the signal generator clutch and initiates an operating cycle.
- 2.03 While the code combination transmitted during the first cycle must be a LETTERS combination, the code combinations of the succeeding 20 cycles may be any arbitrary character determined by the detachable code

blades fastened to the code drum. The code combination on each blade is read by five sensing levers which transfer the code selections to a vertical projection on each of the 5 codebars. Each code combination is thus transmitted in the normal manner by the keyboard signal generator. A spacing condition occurs whenever a codebar is prevented from moving to the right by its associated sensing lever; unrestricted movement of a codebar results in a marking condition. Since the sensing levers must be held away from the codebars in order to prevent their interference during normal keyboard operation, a stop code blade having a LETTERS combination must be employed. This necessity results in a LETTERS combination for the first character.

2.04 Once during each rotation ( $360^{\circ}$ ) of the signal generator cam assembly, the codebar bail is pulled to the left by a cam eccentric causing it to rotate clockwise. The bail thereby resets the keyboard codebars and, with the character generator drive link now in its released position, rotates the drive plate clockwise. This action causes the stepping pawl to step the code drum one position clockwise.

2.05 With the stop lever in its released position, the codebar bail latch operating lever also maintains the codebar bail latch in a released position. The signal generator mechanism will cycle continuously until it rotates the code drum one full revolution or 21 characters. The first code blade, which is the stop code blade having a LETTERS combination, has an additional projection such that when it is being rotated into the sensing position it contacts the stop lever rotating it clockwise. The left extension of the stop lever rotates the codebar bail latch operating lever counterclockwise which in turn releases the codebar bail latch to the action of its attached spring. Continued rotation of the stop lever brings it in a position where if released to the action of the spring attached to the codebar bail latch operating lever, it will reverse rotation and become latched on the stop lever attached to the trip magnet armature. Such a position is reached when the stop code blade passes its area of contact with the stop lever which is just prior to the complete movement of the stop code blade into the sensing position.

2.06 When the codebar bail latch is released to its spring action, it rotates counterclockwise in contact with the codebar bail latch roller until it latches the codebar bail. At this point the blocking lever is also released to its spring action and it rotates counterclockwise until it rests against a projection on the stop lever. In this position the blocking lever holds the drive plate in its extreme position and the attached drive link is once more unable to follow the feeding motion from the codebar bail. Further operation of the signal generator and character generator is thus prevented. At this point the keyboard is restored to its normal operating condition.

**SPECIFICATION 50039S**

**Originating Station**

2.07 When the FIGS upper case D combination is depressed at the originating station, a cam on the signal generator shaft closes a normally open universal keyboard pulsing contact which operates the answer-back control relay. The opening of the FIGS stunt box contact may de-energize the control relay but the closing of the keyboard pulsing contact on the D combination will re-energize the control relay and disable the local answer-back via normally closed control relay contacts in series with the answer-back trip magnet. (The FIGS function box contact is in series with the control relay after the control relay is initially operated. This is a holding circuit for the control relay. The FIGS function pawl has been modified to engage the FIGS function bar at all times. This arrangement advances the timing of the FIGS function box contact in relation to the universal pulsing contact so the control relay will be energized during the entire signal generator cycle.)

2.08 The answer-back message may be changed by replacing the entire code drum of the mechanism. See Paragraphs 3.77(a) through 3.77(i) for the necessary instructions.

2.09 The kits consist of:

<u>Qty.</u>	<u>Part No.</u>	<u>Description</u>	<u>174176</u>	<u>176272</u>
1	1178	Screw	X	X
9	2191	Lockwasher	X	X
1	3598	Nut	X	X
2	3599	Nut	X	X
3	4703	Spring		X
2	4703	Spring	X	
5	7002	Flat washer	X	X
1	45815	Lockwasher	X	X
1	70314	Lockwasher	X	X
1	71073	Flat washer	X	X
3	72522	Wick		X
2	72522	Wick	X	
2	90517	Spring		X
1	90517	Spring	X	
1	93117	Lockwasher	X	X
3	94693	Wick		X
2	94693	Wick	X	
2	110743	Lockwasher	X	X
1	112626	Nut	X	X
1	112627	Nut	X	X
2	121473	Stud	X	X

SPECIFICATION 50039S

<u>Qty.</u>	<u>Part No.</u>	<u>Description</u>	<u>174176</u>	<u>176272</u>
4	151630	Screw	X	X
1	151632	Screw	X	X
1	152121	Function lever		X
1	152642	Function lever	X	X
2	152653	Function pawl		X
1	152653	Function pawl	X	
1	152660	Spring plate	X	X
2	152666	Function bar		X
1	152666	Function bar	X	
1	153520	Function bar		X
1	153521	Function bar	X	
2	153817	Screw	X	X
1	154125	Spring	X	X
1	154613	Latch		X
4	155753	Insulating sleeve	X	X
4	156740	Screw	X	X
3	157200	Spring		X
2	157200	Spring	X	
3	157240	Spring		X
2	157240	Spring	X	
1	157274	Clip	X	X
1	161649	Function lever	X	X
1	161650	Arm	X	X
1	162878	Contact assembly	X	X
1	162885	Segment cam	X	X
2	162886	Screw	X	X
1	163852	HERE IS Keylever assembly	X	X
1	163979	Function lever	X	X
1	164129	Common answer-back parts	X	X
1	164457	WRU Keylever assembly upper case C		X
1	164496	Bail	X	X
1	164497	Eccentric	X	X
1	164499	Lockbar	X	X
1	174177	Contact-suppressor and cable assembly	X	X
1	174180	Cable assembly with control relay	X	X
1	174184	Cover plate	X	X
1	174187	Function box cable assembly	X	X
1	195016	Function pawl assembly	X	X
1	309508	Left bracket	X	X
1	309509	Right bracket	X	X
2	309510	Retainer bar	X	X
1	321727	Guide	X	X

## SPECIFICATION 50039S

2. 10 For part numbers referred to, other than those in the kits, and for parts ordering information see Teletype Model 28 Parts Bulletin 1149B.

### 3. INSTALLATION

- 3.01 Refer to Teletype Model 28 Page Printer Set Bulletin 217B for instructions for removal of major components and assemblies.

Note: References in the text to left or right, up or down, front or rear, apply to the unit in its normal operating position as viewed from the front.

#### Modification Kit 174176

- 3.02 Remove the typing unit from the cabinet in accordance with standard practice. Do not replace until so instructed.
- 3.03 Remove the stunt box from the typing unit in accordance with standard practice.
- 3.04 Loosen the two screws which fasten the stripper bail and locklever bracket (152711 or 153314) to the 150894 guide bar. Replace the keyboard locklever slide arm (150561 or 154649) with the 161650 arm, furnished. Install the 161650 arm with its small curved projection extending upward and to the left of the guide slot (as viewed from the rear of the printer). Tighten the mounting screws.
- 3.05 Install the following parts in slot no. 32.

<u>Part No.</u>	<u>Description</u>
4703	Spring
72522	Wick
90517	Spring
94693	Wick
152642	Function lever
152660	Spring plate
152666	FIGS function bar
157200	Spring
157240	Spring
195016	Function pawl

- 3.06 Install the following parts in slot no. 34.

<u>Part No.</u>	<u>Description</u>
4703	Spring
72522	Wick
90517	Spring
94693	Wick
152642	Function lever
152653	Function pawl
152660	Spring plate
153521	Upper case D function bar
157200	Spring
157240	Spring

- 3.07 Use the 157240 spring and 72522 wick on units having a one stop function clutch; use the 157200 and 94693 wick on units that have a two stop function clutch.
- 3.08 If the printer stunt box is equipped with the blank-blank keyboard lock sequence parts, replace the 152121 function lever in slot no. 35 with the 161649 function lever, furnished. If the stunt box is also equipped with a 152127 clip to disable the blank-blank keyboard lock sequence, this clip must be removed and the 157274 clip, furnished, used when it is desired to disable this feature. The 157274 clip should be installed after the stunt box has been replaced in the printer following Paragraph 3.10. Position the clip with its closed end under the function pawl in slot no. 35 so that it lifts the pawl out of engagement with the function bar when the hooks at the open end of the clip are placed over the 150544 handle.
- 3.09 Install the 172539 switch assembly across stunt box slots 29, 30, 31, and 32.
- 3.10 Replace the stunt box in the printer. Make certain that the 195016 function pawl engages the 152666 FIGS function bar in slot 32. Do not replace the printer.
- 3.11 Make the "FIGURES" STUNT BOX CONTACT adjustment at this time. Refer to Figure 18.
- 3.12 Check and refine FUNCTION BAIL BLADE adjustment according to Teletype Bulletin 217B.
- 3.13 Route the stunt box contact cable assembly to the connector (right) side of the printer. Tie the cable to the 150544 handle at appropriate positions.

## SPECIFICATION 50039S

- 3.14 Remove the keyboard, keyboard hood, and keylever guideplate in accordance with standard practice.
- 3.15 Remove and discard the plastic plug and speed nut from the keytop hole, sixth from the left in top row.
- 3.16 Maneuver the 163979 function lever into the 21st slot of the 154070 code lever guide until it is fully seated on the 154016 codebar lever shaft.
- 3.17 Install a 154125 spring on the 163979 function lever and 154070 code lever guide.
- 3.18 Replace the keylever guideplate on the keyboard in accordance with standard practice. Readjust the spacebar bail pivot. (Refer to Bulletin 217B.) Do not replace the keyboard hood until so instructed.
- 3.19 Remove the lock ball retainer clamp from its present position in the center of the 154175 lock ball channel and install it in the position immediately to the right of center. Some keyboards may not have a lock ball retainer clamp in the center of the lock ball channel. If so, disregard this paragraph.
- 3.20 Install the 163852 keylever assembly (HERE IS) in the keytop guide hole previously unplugged, snapping onto the 163979 function lever previously installed in this position (Figure 1).
- 3.21 Remove the two screws, lockwashers, and flat washers (one at a time on each side), holding the lock ball channel. Install two 121473 studs with the lockwashers and flat washers just removed (Figure 1).
- 3.22 Check and if necessary, make the LOCK BALL CHANNEL adjustment.
- 3.23 Place a 309508 left bracket on top of the 121473 stud on the left side and place a 309509 right bracket on top of the 121473 stud on the right side. Assemble them only friction tight with two 156740 screws, 2191 lockwashers, and 7002 flat washers (Figure 1).
- 3.24 Install one 309510 retainer bar on top and one 309510 retainer bar on the bottom of the 309508 and 309509 brackets. Assemble the above only friction tight with two 156740 screws, 2191 lockwashers, and 7002 flat washers (Figure 1).

Note: Use caution when handling the 309507 contact to be installed according to next paragraph.



- 3.25 Install the 309507 contact assembly (part of 174177 cable assembly) on the 162876 retainer bar and assemble it only friction tight with the 162874 clamp plate, 1178 screw, 71073 flat washer, 93117 lockwasher, and 112627 nut. Move the contact assembly along the retainer bar until it is beneath the 163979 function lever previously installed. Tighten the assembly. Route the white-brown (W-BR) and slate (S) wires through the keyboard base to the signal generator. Tie the cable assembly near the end of retainer bar on both sides of the contact assembly (Figure 1).
- 3.26 Install the resistor-suppressor assembly (part of 174177 cable assembly) on the 154175 lock ball channel by means of the mounting hole on the right side of the channel. Use a 151632 screw, 2191 lockwasher, 7002 flat washer, and 3598 nut to secure the assembly (Figure 2).
- 3.27 Route the purple (P) and slate (S) wires through the keyboard to the motor terminal block. Route the white-slate (W-S), green (G), and white-brown (W-BR) wires with terminals as far as possible toward the rear of the keyboard for later connection to the 174180 control relay assembly. (See 4412WD.)
- 3.28 Route the green (G) and white-green (W-G) wires toward the rear of the keyboard for later connection to the answer-back trip magnet. See Paragraph 2.60.
- 3.29 Remove the 151630 screw and 2191 lockwasher which fasten the front of the 154008 codebar guide, and 154013 bracket and 158230 bracket to the 154068 right side code lever guide bracket. Loosen the rear 151630 mounting screw so that it is friction tight.
- 3.30 Pivot the 154013 bracket upward so that its attached 158228 lever disengages the slot in the 154052 lockbar.
- 3.31 Remove the 151630 screw and 2191 lockwasher which fasten the front of the 154008 codebar guide and 154072 stop bracket to the 154069 left side code lever guide bracket. Loosen the rear 151630 mounting screw so that it is friction tight.
- 3.32 Pivot the 154072 bracket downward so that its stop clears only the 154052 lockbar.
- 3.33 Slide the 154052 lockbar to the right until it clears the right side 154008 codebar guide. Disengage the lockbar from the 154023 lockbar latch and lift it upward and to the left so that it is removed from the code lever guide assembly. Discard the 154052 lockbar.

## SPECIFICATION 50039S

- 3.34 Replace the 154052 lockbar with the 164499 lockbar by reversing the procedure outlined in Paragraphs 2.29 through 2.33 above. Readjust the codebar guide clearance. (Refer to the Model 28 adjustment bulletin.)
- 3.35 Install the 164497 eccentric on the 164496 bail with a 45815 lockwasher and 112626 nut (Figure 19).
- 3.36 Remove the three 139752 screws and 110743 lockwashers which fasten the 154184 rear blade to the 154179 universal bail.
- 3.37 Remove the 3598 nut, 2191 lockwasher, and 7002 washer which fasten the 121242 clamp to the 154149 line break switch cable. Also remove the two 153841 screws and 2191 lockwashers which fasten the 154039 line break switch bracket to the keyboard.
- 3.38 Remove the two 119653 retaining rings from the left side of the 154092 function lever shaft. Slide the shaft to the right until its left end is approximately in line with the roller on the 154239 universal extension mounted on the 154179 universal bail. Note the position of all function levers thus removed from the shaft so that they may be readily replaced.
- 3.39 Rest the keyboard on its back side so that it is supported by the motor. From the bottom of the keyboard, maneuver the 164496 bail with the 164497 eccentric into its proper position on the 154059 function bail bracket. Hold the bail with its long extension upward and its bearing holes at right angles to the 154092 shaft. Insert the long extension of the bail upward through the base cutout in line with the previously installed 163979 **HERE IS** function lever. Position the 164496 bail extension so that it engages the 163979 function lever in a similar manner as the 154099 local carriage return function bail engages its associated function lever. Place the 164496 bail in the function bail bracket slot immediately to the left of the 162979 function lever so that the 164497 eccentric is atop the 154067 keyboard lock function lever. Slide the 154092 shaft to the left into the bearing holes of the 164496 bail and all original function levers previously disengaged. Secure the 154092 shaft with the two 119653 retaining rings previously removed. Refer to Figure 19. Remount the line break switch and cable.
- 3.40 Replace the parts previously removed in Paragraphs 3.36 and 3.37. Make the KEYBOARD LOCK BAIL ECCENTRIC adjustment at this time (Figure 19) and lubricate as shown in Figure 18.
- 3.41 To facilitate installation of the 174180 control relay assembly in the right rear corner of the keyboard base, connect the white-slate (W-S), green (G), and white-brown (W-BR) wires from the 174177 keylever contact cable assembly to the control relay terminal block. See 4412WD.

3. 42 Route the purple (P) and slate (S) wires from the control relay assembly to the motor terminal block.
3. 43 Route the four point connector through the top of the keyboard (Figure 3).
3. 44 Install the 174180 control relay assembly in the right rear of the keyboard with two 151630 screws and two 2191 lockwashers. Install the 174184 control relay cover plate as shown in Figure 3 with two 151630 screws, two 2191 lockwashers, and 70314 flat washer. (The entire control relay assembly is secured at the rear of the keyboard by the 70314 flat washer which overlaps onto the keyboard base.) See Figure 3.
3. 45 Connect the two purple (P) wires previously routed, to terminal one of the motor terminal block. See 4412WD.
3. 46 Connect the two slate (S) wires, previously routed, to terminal two of the motor terminal block. See 4412WD.
3. 47 Remove the signal generator from the keyboard in accordance with standard practice.
3. 48 Remove and discard the two 151737 screws which secure the cam sleeve assembly to the clutch cam disc. Retain the lockwashers.
3. 49 Install the 162885 cam segment with the two 162886 screws and the two lockwashers previously removed (Figure 4). The 162885 cam segment and 162886 mounting screws can be maneuvered into place without removing any parts from the signal generator assembly.
3. 50 Install the 162878 universal pulsing or blinding contact assembly on the 154009 signal generator front plate as shown in Figure 4 using two 151631 screws, two 2191 lockwashers, and two 7002 flat washers.
3. 51 Replace the 154017 eccentric stud with the 173096 eccentric stud. To do so it will be necessary to loosen the signal generator rear plate and codebar bail so the eccentric studs may be maneuvered into and out of the codebar bail (Figure 5).
3. 52 The signal generator rear plate may be loosened by removing the nuts and lockwashers which fasten the plate to the 151207 codebar bail stud, 154018 locking bail post, and 154014 guide post. Also remove the screw which fastens the signal generator frame by means of an L-bracket. Remove the retaining ring from the rear of the 151207 codebar bail stud to loosen the codebar bail. Be sure to replace all parts after the 173096 eccentric has been installed.

## SPECIFICATION 50039S

3. 53 Unhook the 154191 codebar bail latch spring from the 154089 spring post. Remove the 154079 stud and the 158268 codebar bail latch, 154191 spring, 115122 felt washer, and 119651 retaining ring from the signal generator 154102 rear plate. Remove the latch, spring, felt washer, and retaining ring from the stud. Discard the stud, reinstall the 158268 latch, its spring, and felt washer on the 164138 stud. Also place the 173029 latch on the stud so that its hub is adjacent to the latch with its right side projection overlapping the latch. Retain the parts on the stud with the original 119651 retaining ring. Reassemble the 164138 stud and its parts on the signal generator rear plate by maneuvering the parts up from the bottom so that the 173029 lever extends through the cutout in the codebar bail. Fasten the stud with the original lockwasher and nut (Figure 5).

3. 54 Unhook the 154215 codebar bail spring from the 154089 spring post. Remove the 154089 spring post from the 154102 signal generator rear plate and replace it with the 173028 spring post. Replace the 154215 codebar bail spring and 154191 codebar latch spring on the 173028 post. Place the 76422 latch operating lever spring on the 173029 lever only. The 76422 spring should be replaced on the 173028 post after the character generator mechanism has been installed on the keyboard. Refer to Figure 5.

3. 55 Install the 150089 screw and 151880 locknut in the tapped hole located on the right side of the 173029 latch operating lever Figure 5.

3. 56 Place two 155753 plastic tubing insulators over the bare wires of the 174177 keylever cable assembly previously routed to the signal generator. Solder the slate (S) wire to the contact spring and solder the white-brown (W-BR) wire to the contact stiffener of the 162878 pulsing contact (Figure 16 and Paragraph 3.25).

**Note:** Make the 162878 pulsing contact adjustment at this time (Figure 16 and Paragraph 4.04.)

3. 57 Replace the signal generator on the keyboard in accordance with standard practice. Check, and if necessary, make the CODEBAR AND CODE LEVER CLEARANCE, the CODEBAR BAIL, the CODEBAR BAIL AND NONREPEAT LEVER CLEARANCE, the UNIVERSAL BAIL LATCHLEVER, the UNIVERSAL BAIL EXTENSION, the BALL WEDGELOCK AND BALL TRACK CLEARANCE, and the LOCK BALL ENDPLAY adjustments. (Refer to the Model 28 Adjustment Bulletin 217B.)

3. 58 Remove and retain the 151739 keytop arrangement identification screw and its 2191 lockwasher from the keyboard.

3.59 Install the 164142 mounting bracket on the keyboard so that it is offset towards the top. Use the two mounting holes located on the left side of the 156574 spring post on the 154179 universal bail. Fasten the bracket with a 151722 screw and 2191 lockwasher and also the previously removed 151739 identification screw and 2191 lockwasher. Refer to Figure 6.

3.60 Solder the white-green (W-G) and green (G) wires to the magnet as indicated in 4412WD. Use 155753 plastic tubing insulators. Tie the wires to the rear of the magnet yoke making certain that they do not interfere with any moving parts on the answer-back mechanism or keyboard. Refer to Paragraph 3.20.

3.61 Place the 164162 O-ring in the groove on the rim of the 164161 message drum which is furthest from the slot in the center portion of the drum. Install the 164163 stop blade in any slot position in the drum by first inserting the blade under the O-ring and then rotating the blade toward the center of the drum until it is fully seated (Figure 7).

3.62 Referring to Figure 7, code the drum in the following manner:

(a) Almost any answer-back message may be selected as long as it does not contain more than 21 characters including spaces. However, the coding of the message drum always begins with a LETTERS (stop blade) and is normally followed by CARRIAGE RETURN and LINE FEED. The coding also normally ends with CARRIAGE RETURN and LINE FEED. This arrangement insures that the message will appear at the beginning of a line on the distant station and that overprinting of the message will not occur. Transmission of the LETTERS code combination at the beginning of the message also returns all stations in the circuit to the unshift position. Since 5 of the 21 available characters are used to perform these functions, only 16 are available for the message itself. This procedure may be alternated to suit a particular application of the answer-back mechanism.

(b) Code the drum in a counterclockwise direction beginning with the no. 2 164164 code blade adjacent to the 164163 stop blade. Each 164164 code blade is provided with removable tines for all levels of the transmission code (1, 2, 3, 4, 5). A "0" code level tine has been provided on each blade for future usage on six level keyboards and may be currently disregarded. A blade is coded by breaking off the unwanted tines at the scored line at the base of each tine. Figure 9 indicates which tines are to be removed for a particular character. To prevent distortion of a code blade, each blade should be held securely near the score mark of the tine to be removed. Although twenty code blades are sufficient to completely code the drum, twenty-five such blades have been provided to allow for

## SPECIFICATION 50039S

possible errors in coding. Since each slot position in the drum must be occupied by a code blade, the unused characters under the twenty permitted for customer use should be coded either for LETTERS or BLANKS or some such tolerable character.

(c) Install each coded 164164 blade in the proper slot position in the drum by first inserting the blade under the O-ring and then rotating the blade toward the center of the drum until it is fully seated. After filling the code drum, encircle the code blades by placing another 164162 O-ring in the groove on the opposite rim of the 164161 drum.

3.63 Apply a thin film of grease on the shaft of the 164165 drive plate.

Install the message drum complete with coded blades and O-rings on the shaft of the drive plate. Depress the stepping pawl extension to raise the pawl sufficiently so that the drum bears against the hub of the drive plate and the pawl fully engages the projections on the code blades. Hold the assembled parts approximately as indicated in Figure 8 by means of the thumb and first two fingers of the left hand. Slide the drive plate shaft downward along the left sides of the curved slots in the 164144 side plates until the drum assembly is fully seated as indicated.

3.64 To facilitate the adjustment of the character generator mechanism, the following adjustments should be made before the mechanism is installed on the keyboard: MAGNET YOKE (Figure 9), STOP LEVER LATCH (Figure 10).

3.65 After making the MAGNET YOKE and STOP LEVER LATCH adjustments, remove the message drum by reversing the procedure used in its installation. The answer-back mechanism may now be installed by the keyboard. With the parts assembled as indicated in Figure 6, maneuver the character generator mechanism so that the left side projection of the 164146 stop lever is under the 150089 screw fastened to the 173029 latch operating lever and the front portion of the 164143 mounting plate is resting on the keyboard base while the rear portion of the 164163 plate is resting on the 164142 mounting bracket. Assemble the 164143 mounting plate only friction tight to the keyboard and bracket by means of 153537 screws, 2191 lockwasher, and 7002 flat washers placed in the rear and right front mounting slots of the plate. See Figure 6.

3.66 To facilitate the adjustment of the answer-back mechanism, the following adjustment should be made when the mechanism is being installed on the keyboard after the signal generator has been replaced: MOUNTING PLATE (Figure 11).

- 3.67 Assemble the 173095 and 164160 drive links together as indicated on Figure 8. Use two 151152 screws, 3640 lockwashers, and 125011 flat washers to assemble the parts only friction tight. Install the assembled drive links on the appropriate shoulder of the 173096 codebar reset bail eccentric stud. Rest the 164160 link along the rear side of the front 164144 side plate of the answer-back mechanism. Install the 90573 spring in the spring eye or the 164160 link.
- 3.68 Install the drive plate assembly without the message drum on the character generator mechanism as previously described. Hook the 90573 spring on the 164169 eccentric stud making certain that the slot in the 164160 drive link engages the stud on the drive plate.
- 3.69 Make the following answer-back generator adjustment at this time:  
DRIVE LINK (Figure 12).
- 3.70 Unhook the 90573 drive link spring from the 164169 eccentric stud. Disengage the slot in the 164160 drive link from the stud on the 164165 drive plate. Remove the drive plate assembly from the character mechanism. Install the message drum on the drive plate shaft and install the drum and drive plate assembly on the mechanism as previously described. Rehook the 90573 spring on the 164169 stud. Make certain that the slot in the 164160 drive link engages the stud on the drive plate; if necessary turn the drive plate with its attached stepping pawl held out of the engagement with the code blades so that the parts are properly aligned.
- 3.71 Make certain that the 164146 stop lever is latched on the 164158 latch. Install the 76422 spring for the codebar bail latch operating lever on the 173028 post.
- 3.72 Make the following final answer-back generator adjustments:  
STEPPING PAWL (Figure 13), LATCH OPERATING LEVER ADJUSTING SCREW (Figure 14).
- 3.73 Again make certain that the 164146 stop lever is latched on the 164158 latch and also that the signal generator clutch is disengaged. Turn the message code drum clockwise until it is in its fully detented position and the 164154 sensing levers are resting on the 164163 stop blade which is just below the pawl shaped surface on the upright projection of the 164146 stop lever. Refer to Figure 8.
- 3.74 Lubricate the answer-back mechanism in accordance with Paragraphs 4.01 and 4.02. Make the HERE IS keylever switch adjustments in accordance with Paragraph 4.03.

**SPECIFICATION 50039S**

**3.75** Replace the keyboard hood, keyboard and typing unit in accordance with standard practice.

**Modification Kit 176272**

**3.76** Installation of the 176272 kit is the same as kit 174176 except that Paragraphs 3.05 through 3.09 are replaced by 3.76 (a) through 3.76 (g) and 3.76 (h) is inserted between 3.20 and 3.21.

(a) Install the following parts in slot no. 32:

Note: If slot 32 is not available install these parts in slot no. 26.

<u>Part No.</u>	<u>Description</u>
4703	Spring
72522	Wick
94693	Wick
152666	FIGS Function bar
157200	Spring
157240	Spring
195016	Function pawl

(b) Install the following parts in slot no. 33:

<u>Part No.</u>	<u>Description</u>
4703	Spring
72522	Wick
90517	Spring
94693	Wick
152121	Function lever
152653	Function pawl
152666	FIGS Function bar
154613	Latch
157200	Spring
157240	Spring

(c) Install the following parts in slot no. 34:

<u>Part No.</u>	<u>Description</u>
4703	Spring
72522	Wick
90517	Spring
94693	Wick



<u>Part No.</u>	<u>Description</u>
152642	Function lever
152653	Function pawl
152660	Spring plate
153520	C function bar
157200	Spring
157240	Spring

- (d) Use the 157240 spring and 72522 wick on units having a one stop function clutch; use the 157200 spring and 94693 wick on units having a two stop function clutch.
  - (e) If the printer stunt box is equipped with the blank-blank keyboard lock sequence parts, replace the 152121 function lever in slot 35 with the 161649 function lever, furnished. If the stunt box is also equipped with a 152127 clip to disable the blank-blank keyboard lock sequence, this clip must be removed and the 157274 clip, furnished, used when it is desired to disable this feature. The 157274 clip should be installed after the stunt box has been replaced in the printer. Position the clip with its closed end under the function pawl in slot no. 35 so that it lifts the pawl out of engagement with the function bar when the hooks at the open end of the clip are placed over the 150544 handle.
  - (f) Install the 172539 switch assembly (part of 174187 cable assembly) across stunt box slots numbers 31, 32, 33, and 34.
  - (g) Replace the stunt box in the printer. Make the FIGURES CONTACT adjustment at this time. Do not replace the printer.
  - (h) Remove the existing C keylever assembly and replace with the 164457 WRU upper case C keylever assembly.
- 3.77 To make the answer-back message code drum change, see Paragraph 1.08, Figure.8, and the following:
- (a) Unhook the 90573 drive link spring from the 164169 eccentric stud.
  - (b) Disengage the slot in the 164160 drive link from the stud on the 164165 drive plate.
  - (c) Grasp the code drum with the thumb and first two fingers of the left hand and while pushing the entire assembly to the right, lift the drum and its drive plate out of the mechanism. Slide the drum assembly from the shaft of the drive plate and replace it with the one desired.

## **SPECIFICATION 50039S**

- (d) Depress the stepping pawl extension to raise the pawl sufficiently so that the new drum bears against the hub on the drive plate and the pawl fully engages the projections on the code blades.
- (e) Hold the assembled parts as shown on Figure 8 and reinsert them in the answer-back mechanism by reversing the disassembly instructions.
- (f) Hook the 90573 spring on the 164169 eccentric stud.
- (g) Make certain that the slot in the 164160 drive link engages the stud on the drive plate; if necessary, turn the drive plate with its attached stepping pawl held out of engagement with the code blades so that the parts are properly aligned.
- (h) If the codebar bail latch has been released during the above procedure, relatch the 164146 stop lever on the 164158 armature latch and turn the motor handwheel or signal generator shaft until the signal generator clutch is disengaged.
- (i) Turn the code drum clockwise until it is fully detented position the sensing levers are resting on the 164133 stop blade which is just below the pawl shaped surface of the upright projection of the 164146 stop lever.

### **4. ADJUSTMENTS AND LUBRICATION**

- 4.01 For standard adjustments and standard lubrication procedure, refer to Teletype Model 28 Page Printer Set Bulletin 217B (Bell System refer to standardized information).
- 4.02 Make the subject kit adjustments and lubrication as given in the text and referring to the appropriate attached figures.
- 4.03 Make the following **HERE IS** keylever adjustments before the keyboard hood is reinstalled on the keyboard. See Figure 1.
  - (a) KEYLEVER SWITCH POSITION (PRELIMINARY)

#### **Requirement**

The centerline of the insulated portion of the universal contact assembly should align with the centerline of the codebar lever.

#### **To Adjust**

Loosen the screw holding the universal contact assembly to the retainer bar and adjust. Tighten the screw.

(b) KEYLEVER SWITCH HORIZONTAL POSITION

Requirement

The centerline of the insulated portion of the universal contact assembly should align with the centerline of the lowermost portion of the codebar lever.

To Adjust

Loosen the two screws holding the retainer bar to the brackets and adjust. Tighten the screws.

(c) KEYLEVER SWITCH VERTICAL POSITION

(1) Requirement

With the keylever in the unoperated position, there should be 0.015 inch to 0.025 inch clearance between the center and lower contacts.

To Adjust

Bend upper contact spring to meet requirement.

(2) Requirement

Pull up 163979 function lever with a spring hook at rear of codebar basket alongside of upstop bar until the lobe on the front of the 163979 function lever touches the insulator of the center contact; there should be at least 0.010 inch between the center and lower contacts.

(3) Requirement

Center and lower contacts should close with some overtravel when keylever is depressed with 16 oz pressure using a 32 oz spring scale.

To Adjust

Loosen the two 156740 screws which fasten the two 162875 brackets on the two 121473 studs and position the complete mounting assembly.

4.04 Make the 162878 pulsing contact adjustment referring to Figures 15, 16, and 17 (note on page 10).

(1) Requirement

With the pulsing contact installed on the signal generator, there should be at least 0.010 inch clearance between the contact guard and the rocker bail assembly. Refer to Figure 18.

## SPECIFICATION 50039S

### To Adjust

Loosen the two contact assembly mounting screws and position the contact assembly.

### (2) Requirement

Rotate the main shaft until the lower extension of the cam follower arm rests on the high part of the cam. The clutch should now be in a latched position. There should be 0.015 inch to 0.025 inch clearance between the contact points. Refer to Figure 15.

### To Adjust

Loosen the two mounting bracket screws, leaving the bottom screws friction tight and position the mounting bracket to meet this requirement. Tighten the mounting screws.

### (3) Requirement

There should be at least 0.015 inch clearance between the lower extension of the cam follower arm and the inside surface of the clutch disc.

### To Adjust

Loosen the two mounting screws and position the cam follower hinge. Refer to Figure 16.

**Note:** When checking this adjustment, rotate the main shaft several times and check the entire cycle. Make sure the lower extension of the follower arm does not come in contact with the adjusting disc mounting screws.

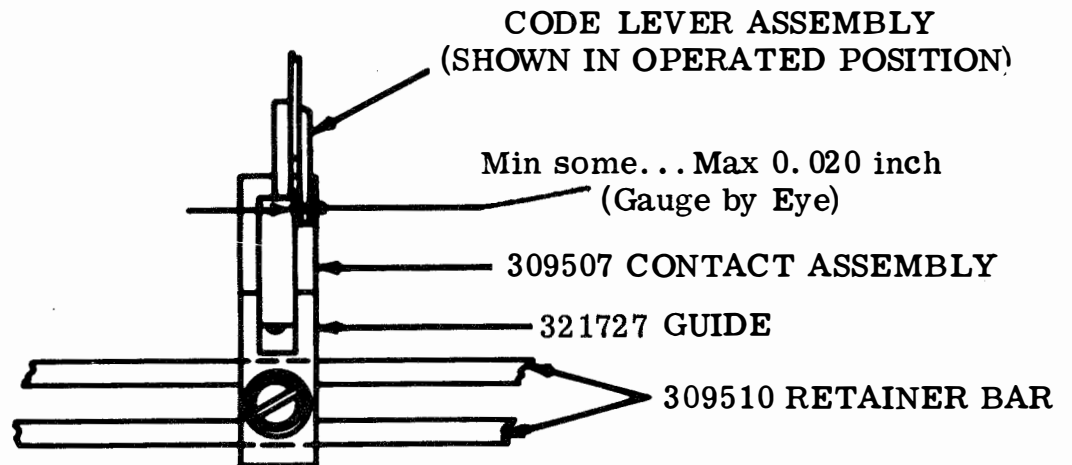
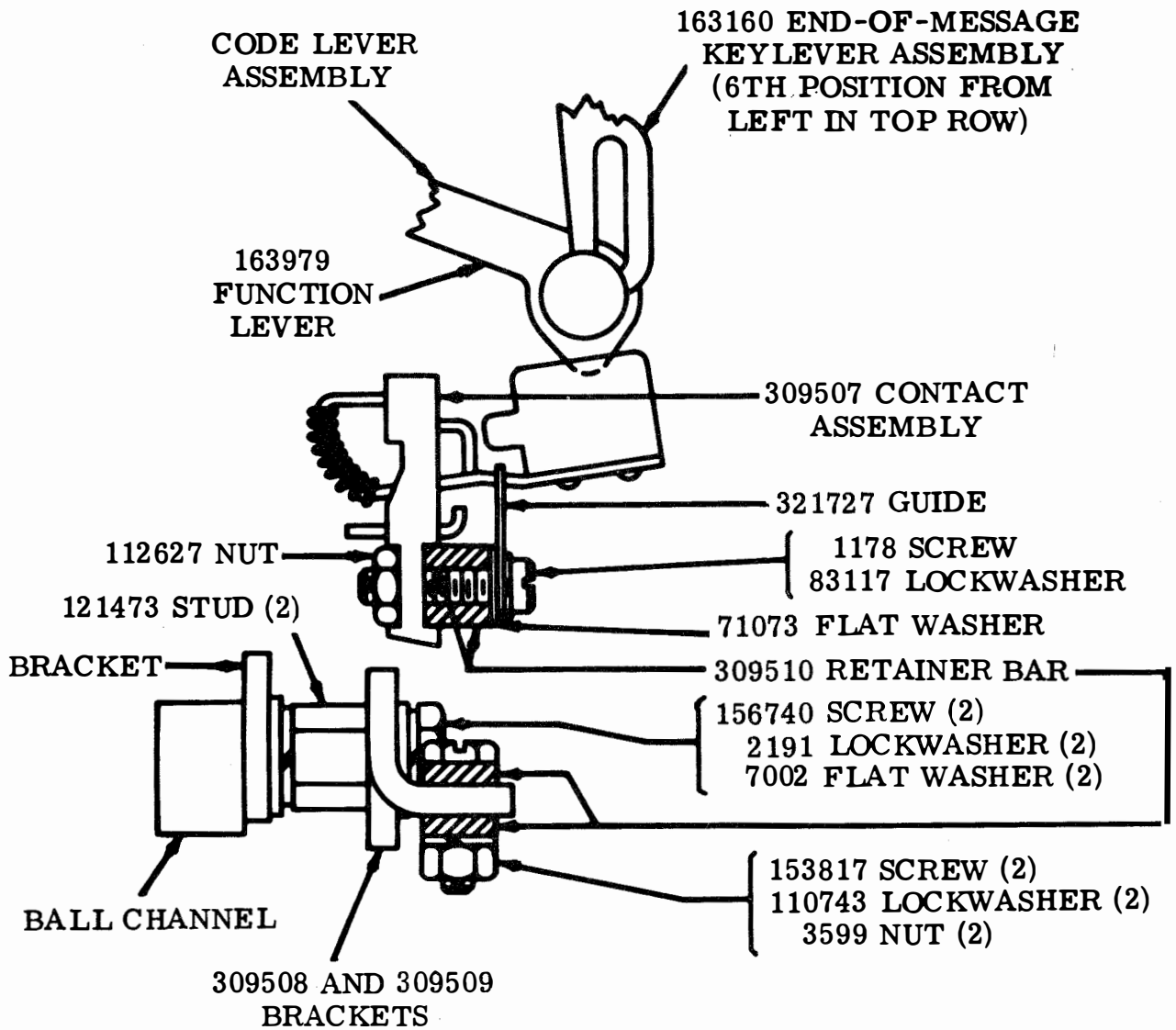

Figure 1

RIGHT SIDE OF CHANNEL

RESISTOR-SUPPRESSION  
MOUNTING, PART OF  
174177 KEYLEVER CONTACT  
CABLE ASSEMBLY

ROUTE TOWARD REAR OF KEYBOARD

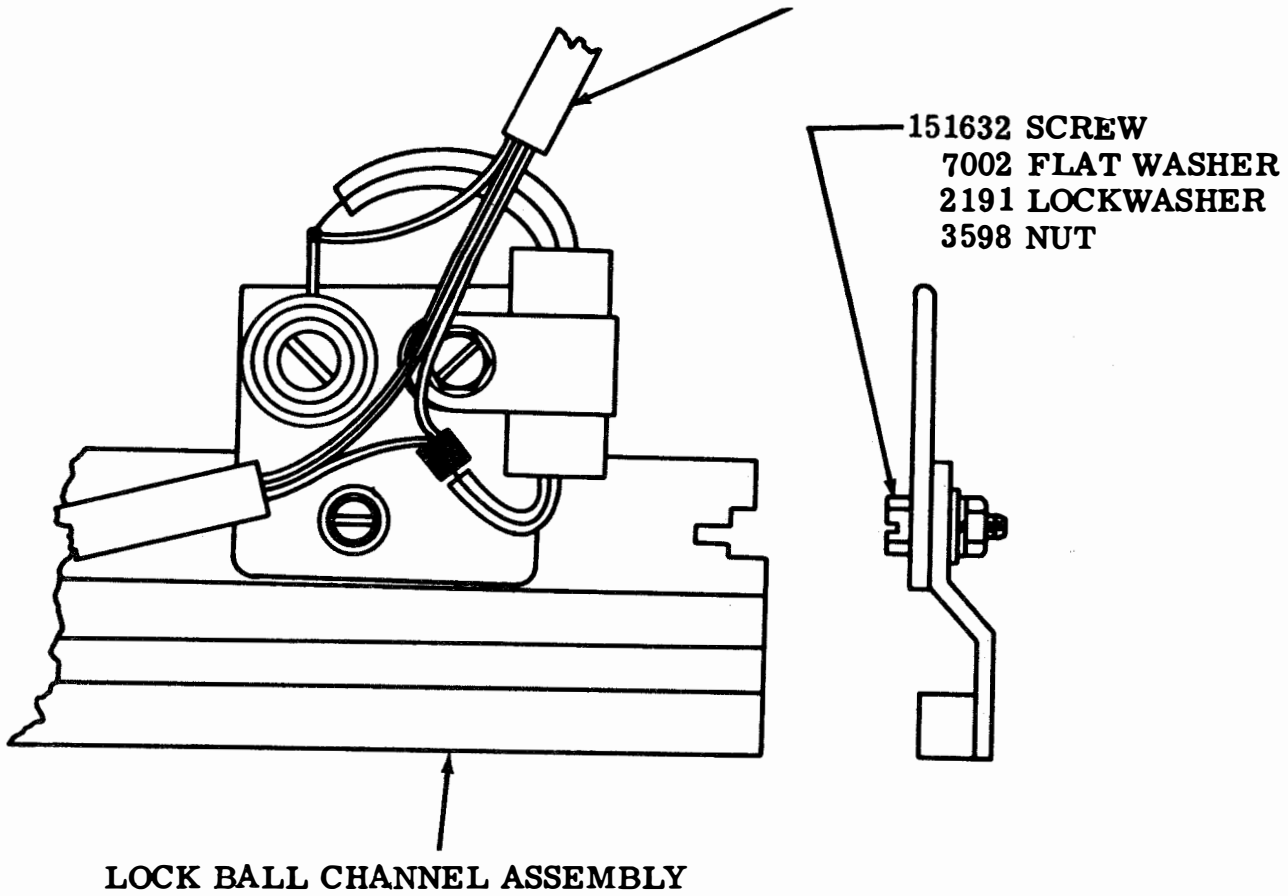

Figure 2

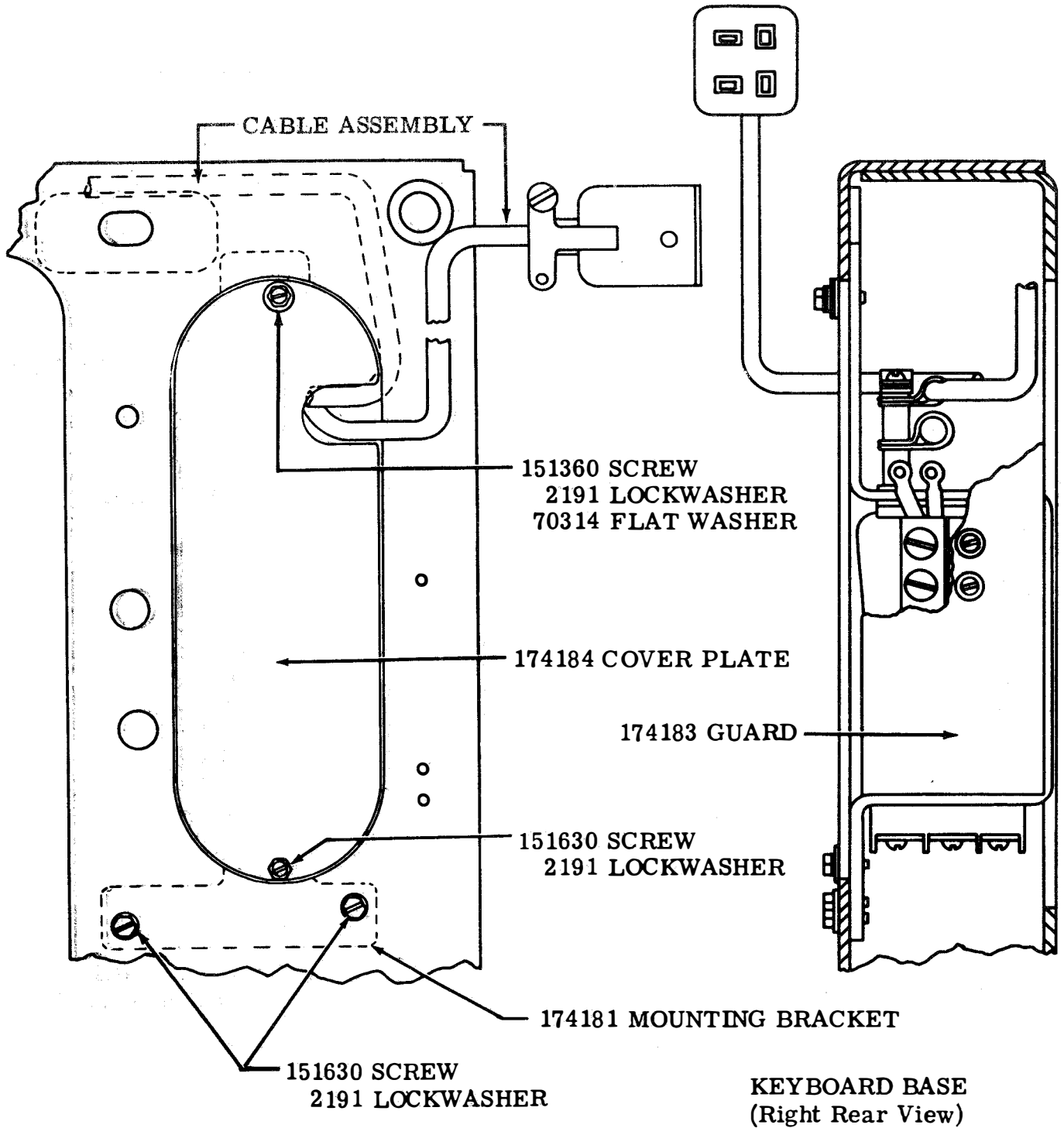

Figure 3

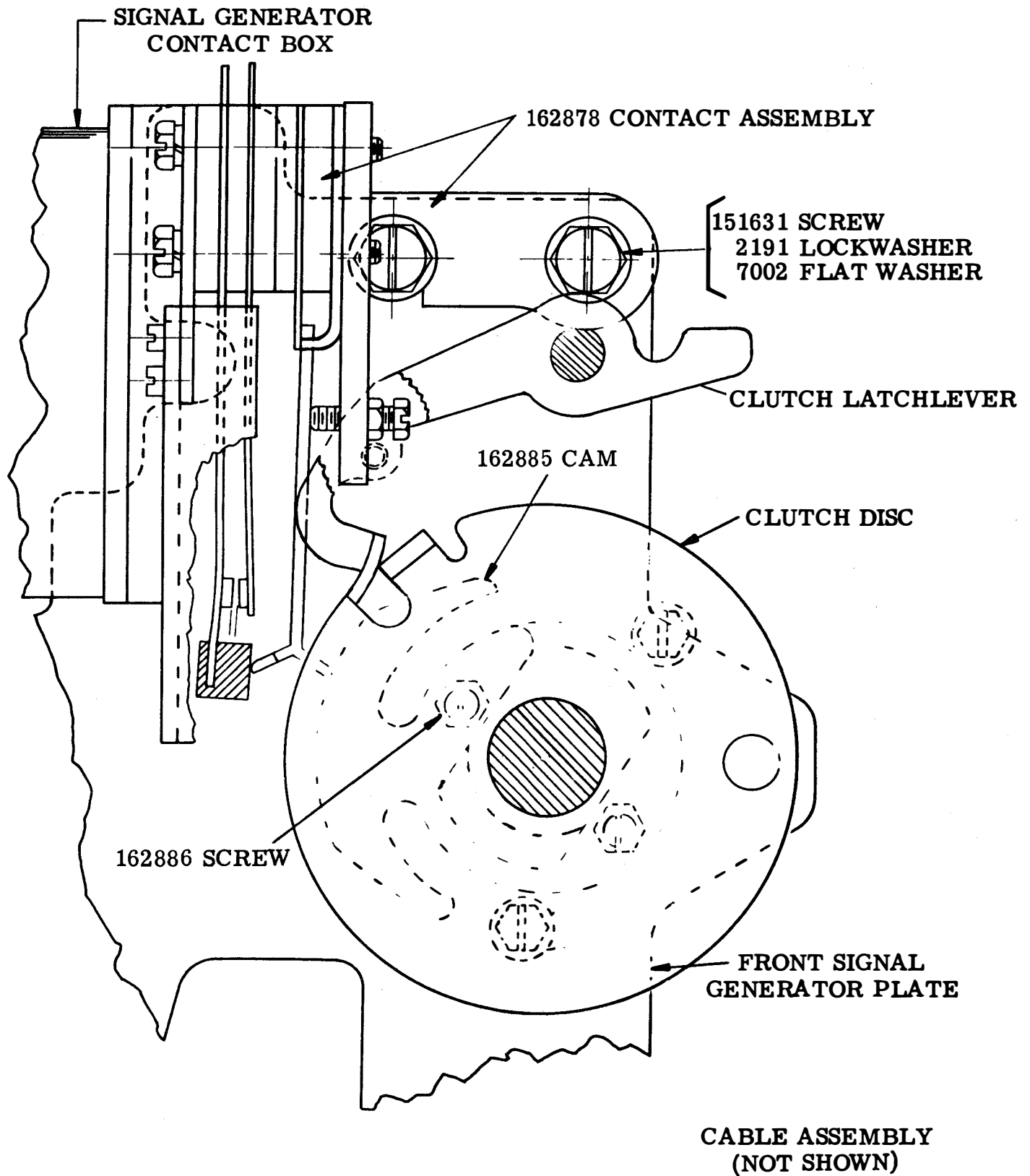

Figure 4 - Partial View of Signal Generator from Rear



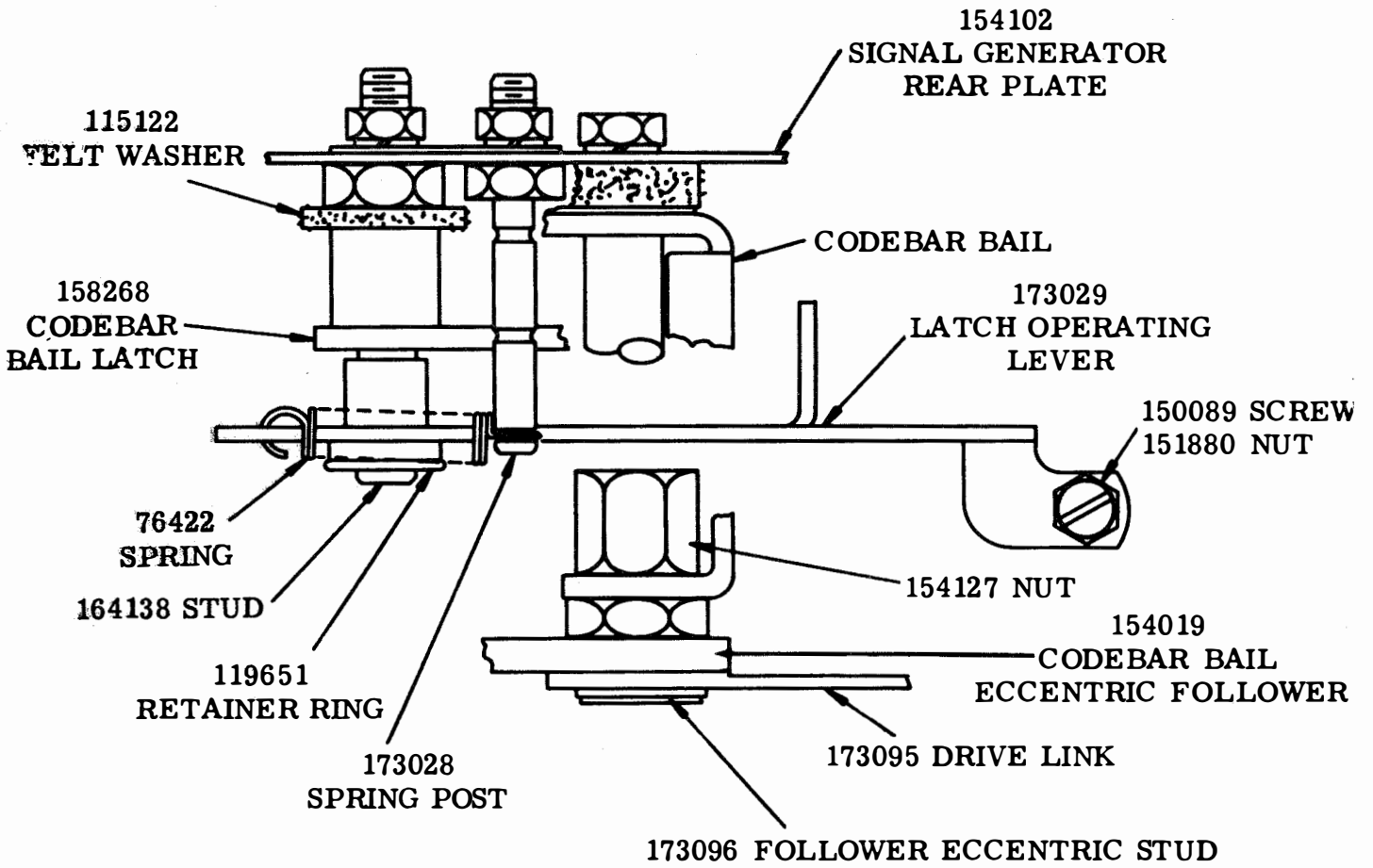
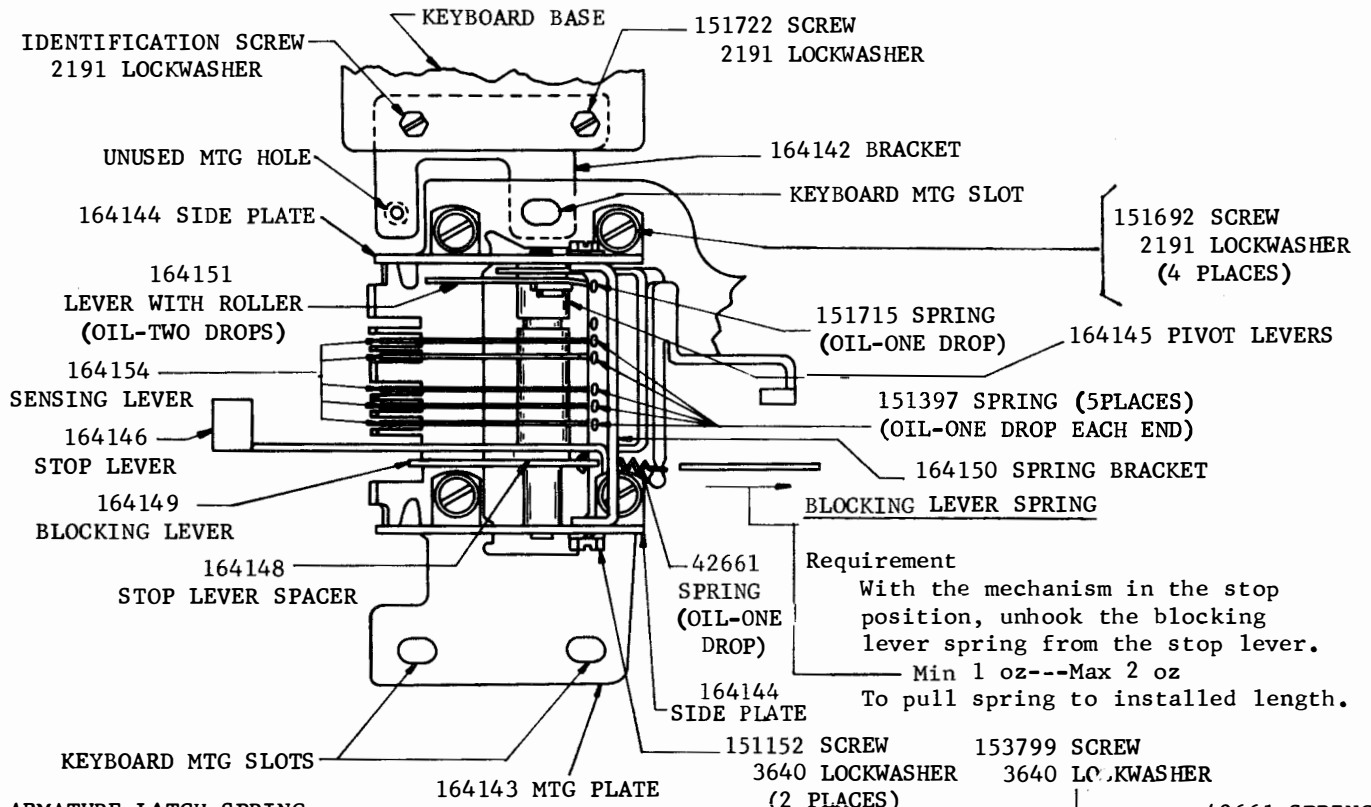

Figure 5

**SPECIFICATION 50039S**



**ARMATURE LATCH SPRING**

**Requirement**

With the mechanism in the stop position, unhook the armature latch spring from the spring post on the magnet yoke,

Min 2 oz---Max 4 oz

To pull spring to installed length.

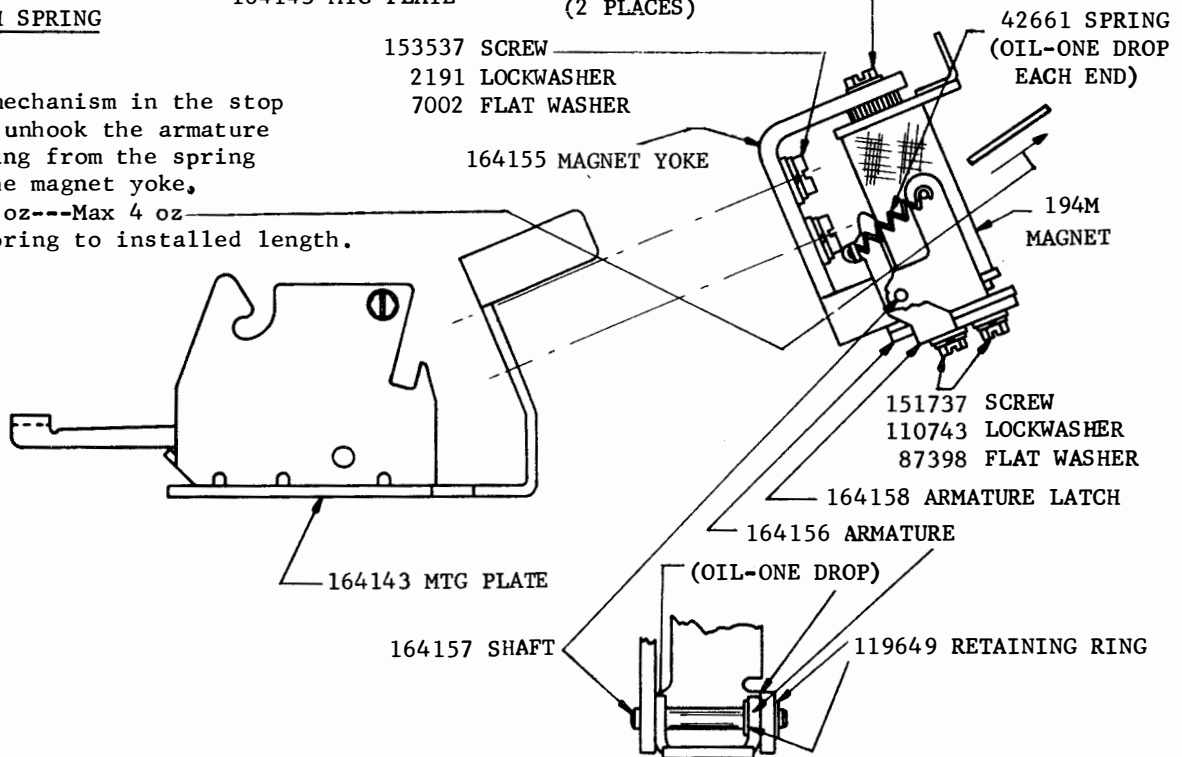

**Figure 6**

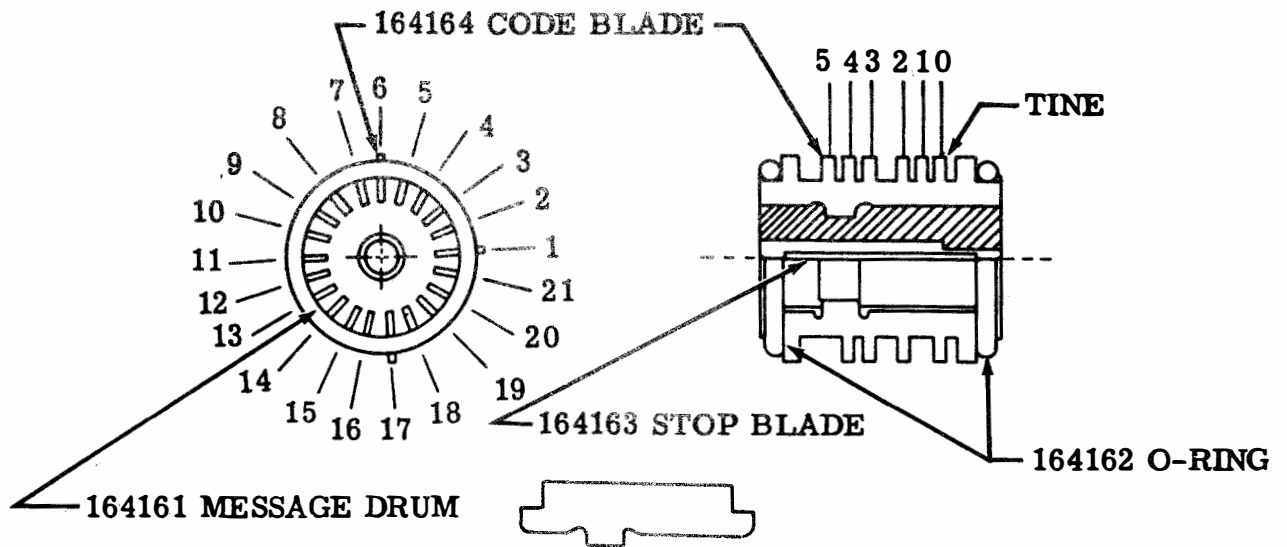

LETTERS	TYPICAL FIG. ARRGT.	CODE				
		1	2	3	4	5
A	—	■	■	■	■	■
B	?	■	■	■	■	■
C	:	■	■	■	■	■
D	\$	■	■	■	■	■
E	3	■	■	■	■	■
F	!	■	■	■	■	■
G	&	■	■	■	■	■
H	#	■	■	■	■	■
I	8	■	■	■	■	■
J	'	■	■	■	■	■
K	(	■	■	■	■	■
L	)	■	■	■	■	■
M	.	■	■	■	■	■
N	,	■	■	■	■	■
O	9	■	■	■	■	■
P	0	■	■	■	■	■
Q	!	■	■	■	■	■
R	4	■	■	■	■	■
S	BELL	■	■	■	■	■
T	5	■	■	■	■	■
U	7	■	■	■	■	■
V	:	■	■	■	■	■
W	2	■	■	■	■	■
X	/	■	■	■	■	■
Y	6	■	■	■	■	■
Z	"	■	■	■	■	■
CARRIAGE RETURN		■	■	■	■	■
LINE FEED		■	■	■	■	■
LETTERS SHIFT		■	■	■	■	■
FIGURES SHIFT		■	■	■	■	■
SPACE		■	■	■	■	■
BLANK		■	■	■	■	■

■ — LEAVE TINE  
 □ — REMOVE TINE

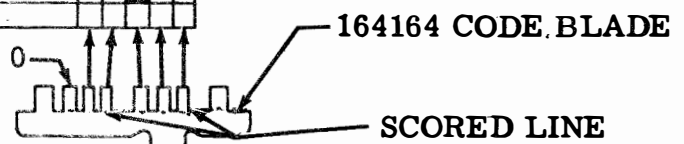

Figure 7

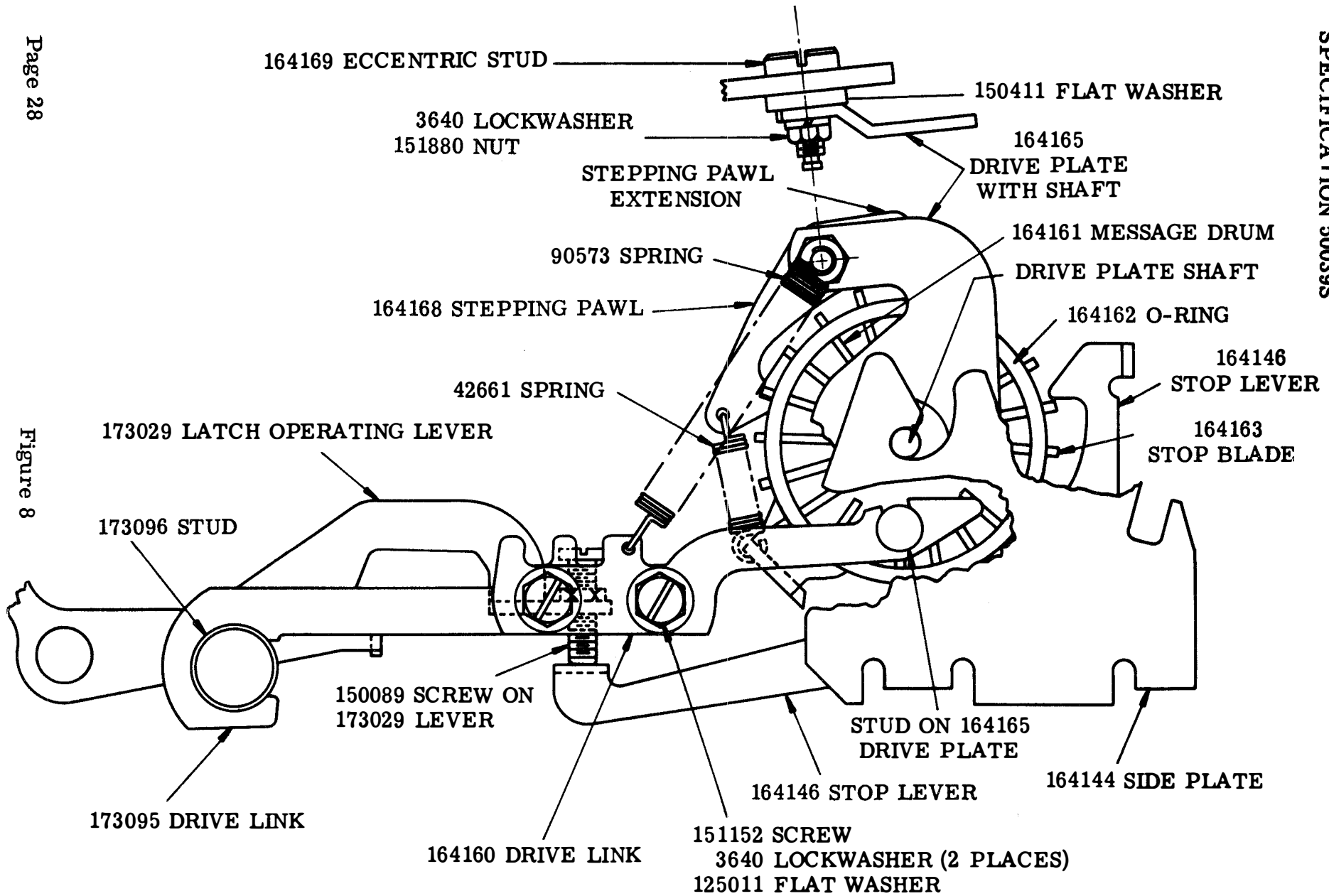
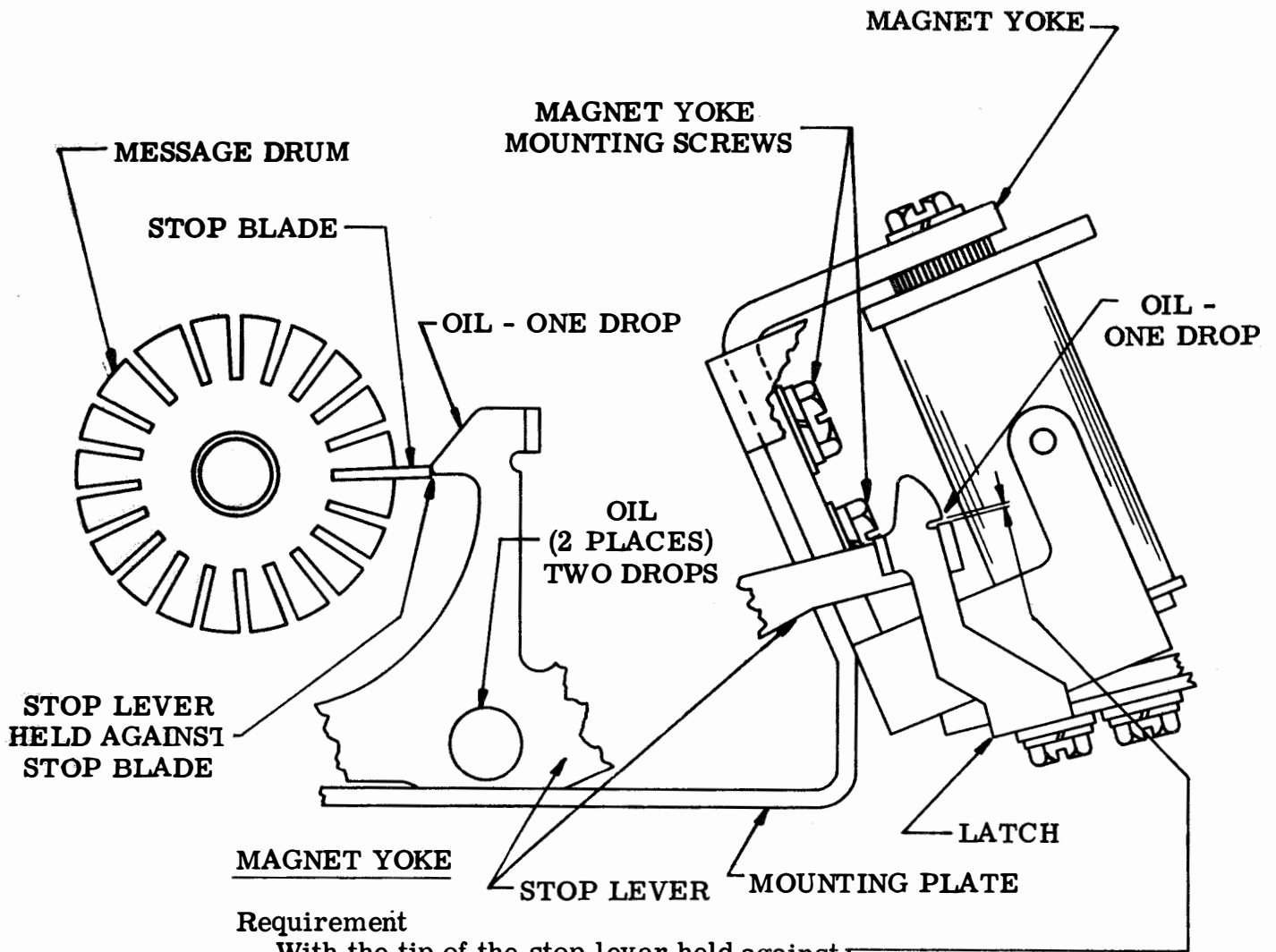

Figure 8



**Requirement**

With the tip of the stop lever held against the stop blade there should be from  
 Min 0.005 inch---Max 0.015 inch  
 clearance between the latching surfaces on the stop lever extension and its latch.

**To Adjust**

Rotate the message drum to meet the requirement and then position the magnet yoke by means of its two mounting screws.

Figure 9

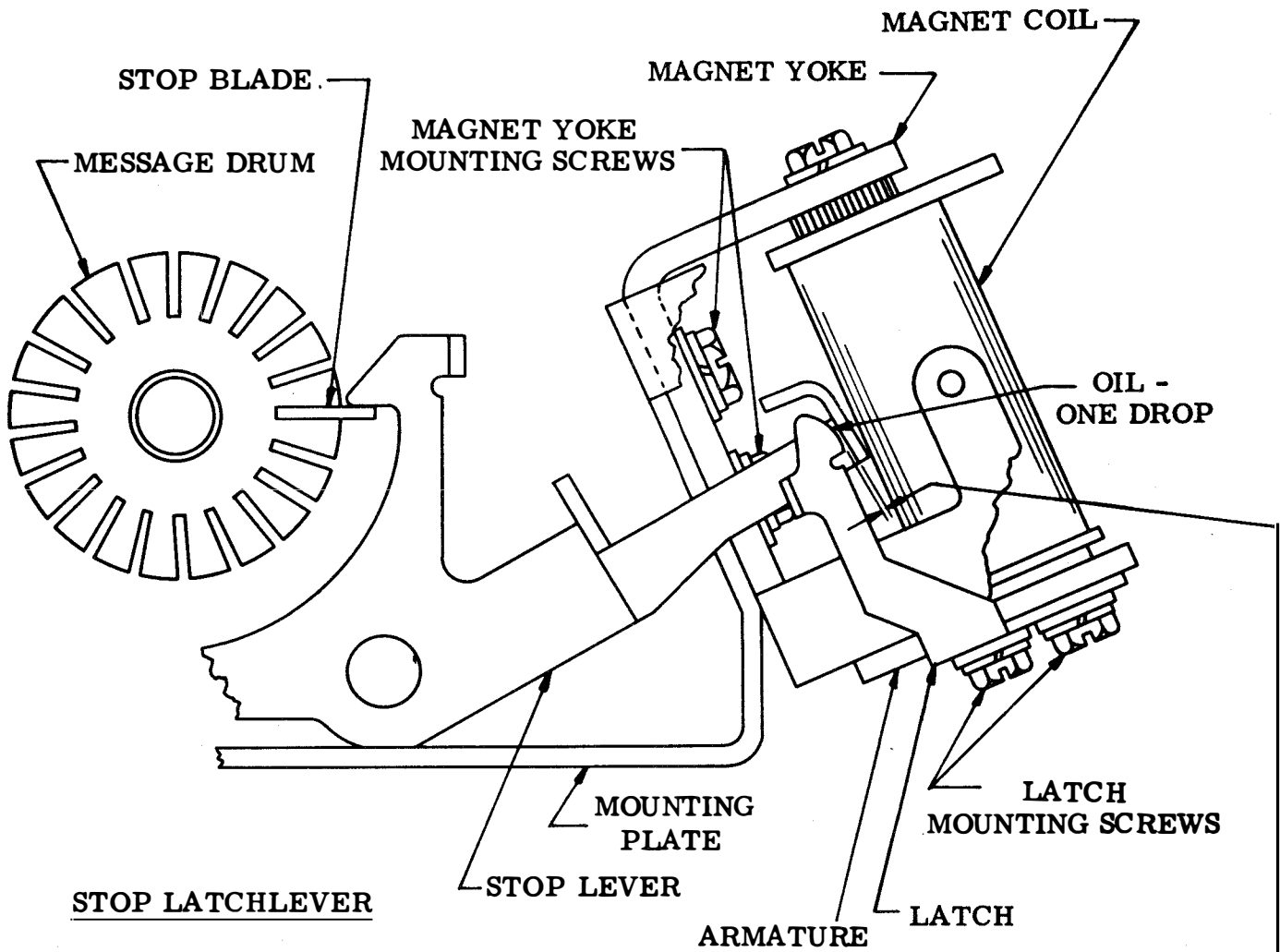

**Requirement**

With the armature held against the magnet core and the stop lever held in its extreme counterclockwise position there should be

Min 0.002 inch---Max 0.007 inch

clearance between the stop lever and its latch. There should also be a minimum of 0.002 inch clearance between the stop lever and its latch throughout the complete travel of the stop lever.

**To Adjust**

Position the latch by means of its two mounting screws.

**SENSING LEVER SPRINGS SPECIFICATION 50039S**

**Requirement**

With the mechanism in stop position and the message drum removed  
 Min 1/4 oz---Max 1-1/4 oz  
 to start each lever moving.

SENSING LEVERS RESTING ON MOUNTING PLATE

DETENT LEVER RESTING ON MOUNTING PLATE

**DETENT LEVER SPRINGS**

**Requirement**

With the mechanism in stop position and the message drum removed  
 Min 22 oz---Max 26 oz  
 to start lever moving.

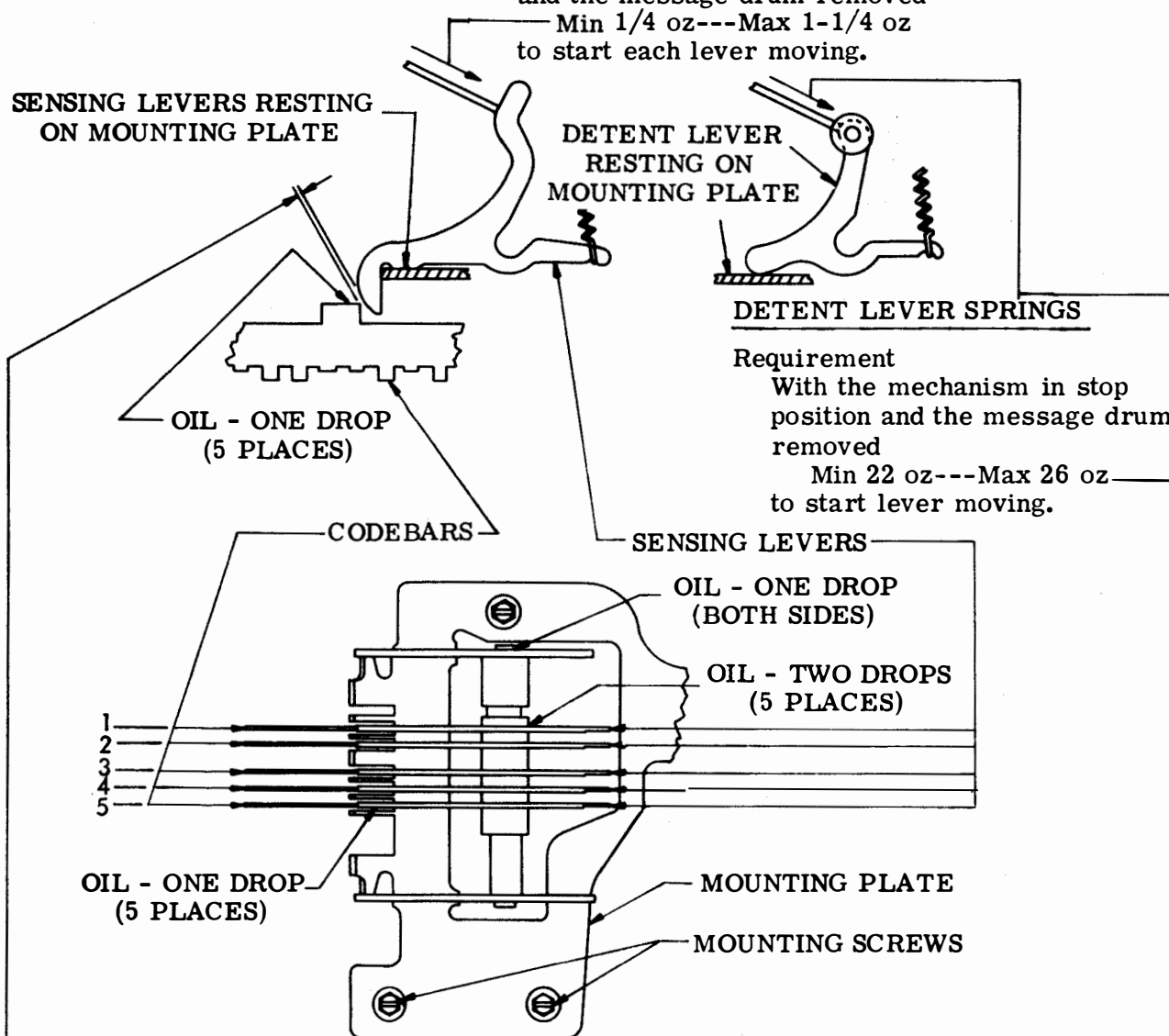

**CHARACTER GENERATOR MOUNTING PLATE**

**Requirement**

Signal generator clutch disengaged. (1) Sensing levers centrally located on codebars so that each lever rests on the full width of its associated codebar. (2) Clearance between shoulders of codebars no. 1, no. 5, and their associated sensing levers.

Min 0.002 inch---Max 0.012 inch

**To Adjust**

Position the mounting plate with the three mounting screws loosened. This adjustment is facilitated by removing the message drum and drive plate assembly from the mechanism.

Figure 11

DRIVE LINK SPRING

Requirement

With mechanism in stop position  
 Min 10 oz---Max 15 oz  
 to pull spring to installed length.

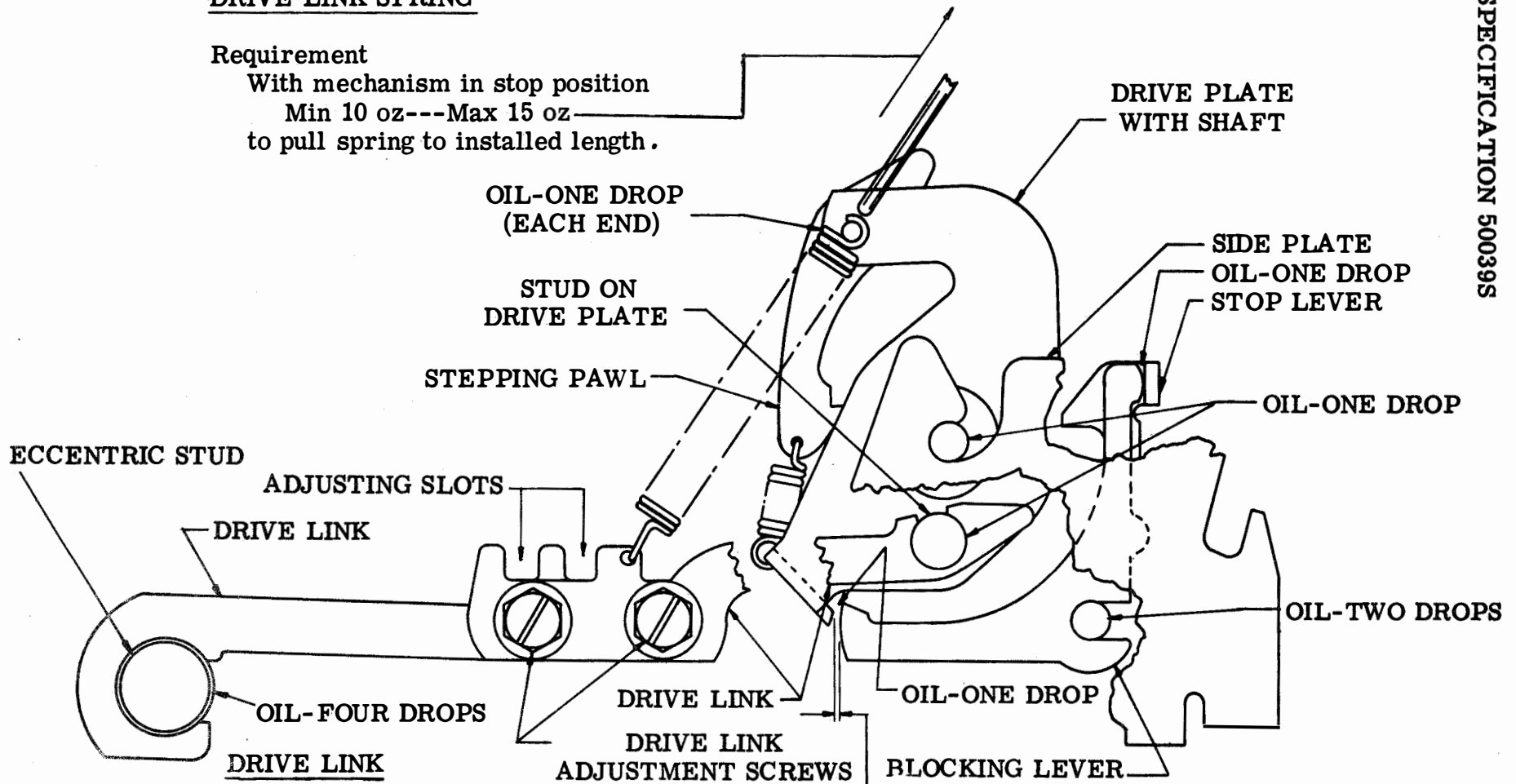

Figure 12

Requirement

In keyboard mechanism, signal generator cam eccentric and arm holding codebar bail in extreme reset position to the left. There should be

Min 0.002 inch---Max 0.007 inch  
 clearance between the drive plate extension and the blocking lever.

To Adjust

Position the two drive links relative to each other by means of the adjusting slots and screws.



Figure 13

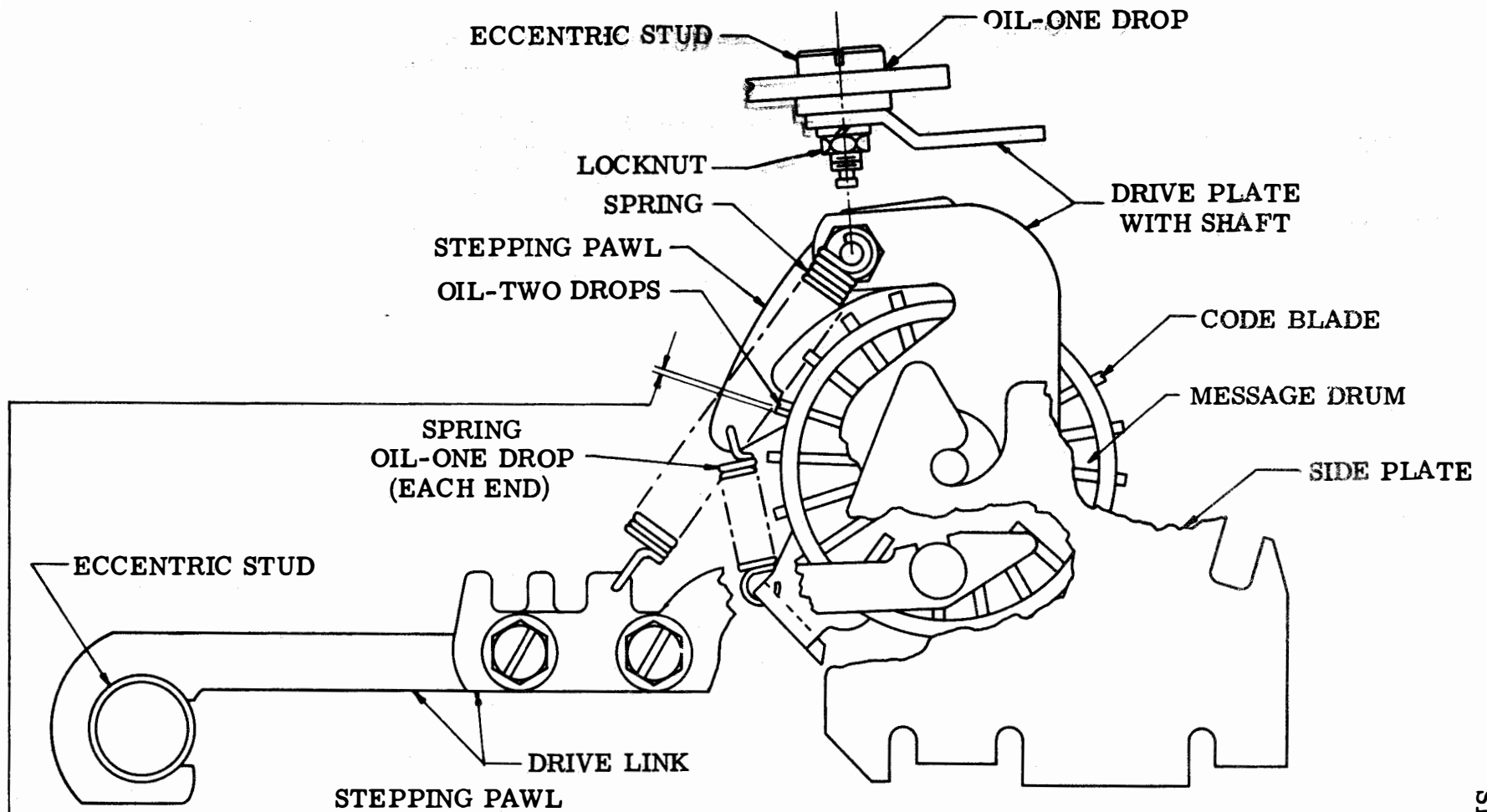

**Requirement**

Message drum in fully detented position. Signal generator cam and arm holding codebar bail in extreme reset position to the left. There should be  
 Min 0.018 inch---Max 0.030 inch  
 clearance between the stepping pawl and any code blade.

**To Adjust**

Position the eccentric stud with its locknut loosened so that its high point is toward the top.

STEPPING PAWL SPRING

Requirement  
 With mechanism in stop position  
 Min 2-1/2 oz---Max 3-1/2 oz  
 to start pawl moving.

LATCH OPERATING LEVER SPRING

Requirement  
 With mechanism in stop position  
 Min 5 oz---Max 6 oz  
 to start lever moving.

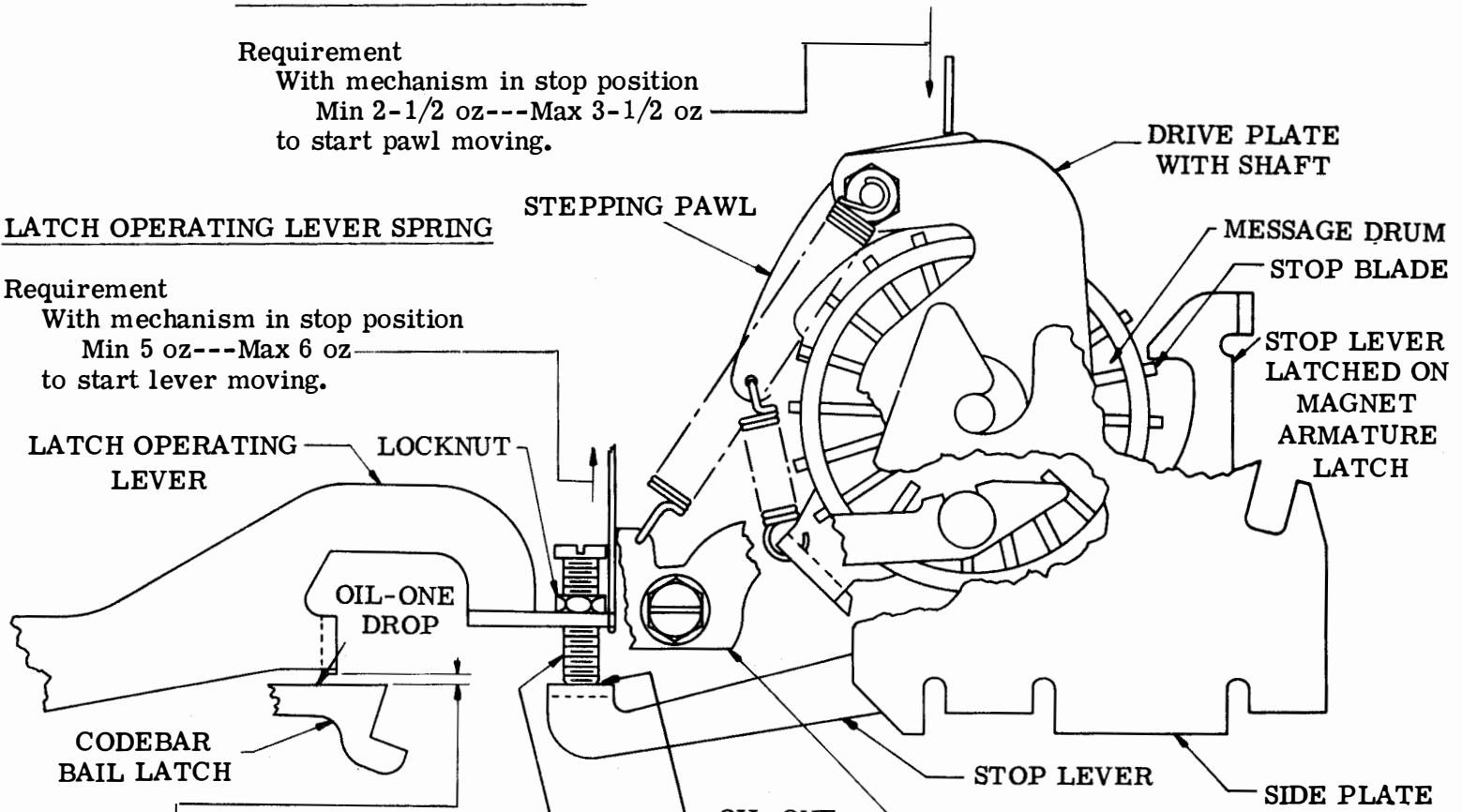

Figure 14

ADJUSTING SCREW ON  
 LATCH OPERATING LEVER

LATCH OPERATING LEVER ADJUSTING SCREW

Requirement  
 Stop lever latched on magnet armature latch. Signal generator clutch fully disengaged.  
 There should be  
 Min 0.005 inch---Max 0.015 inch  
 clearance between the extension on the latch operating lever and codebar bail latch.

To Adjust  
 Position the latch operating adjusting screw with its locknut loosened.

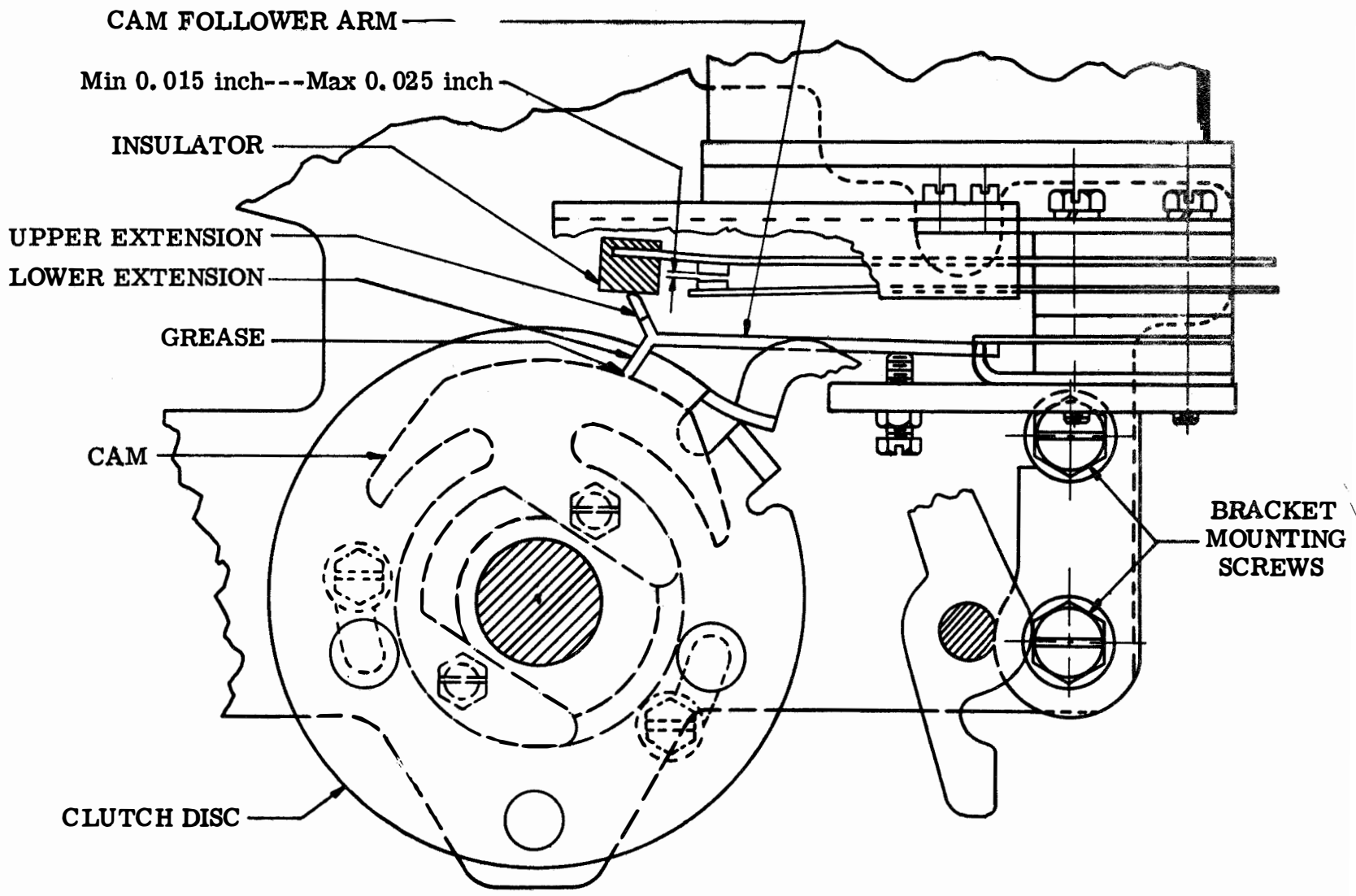

Figure 15

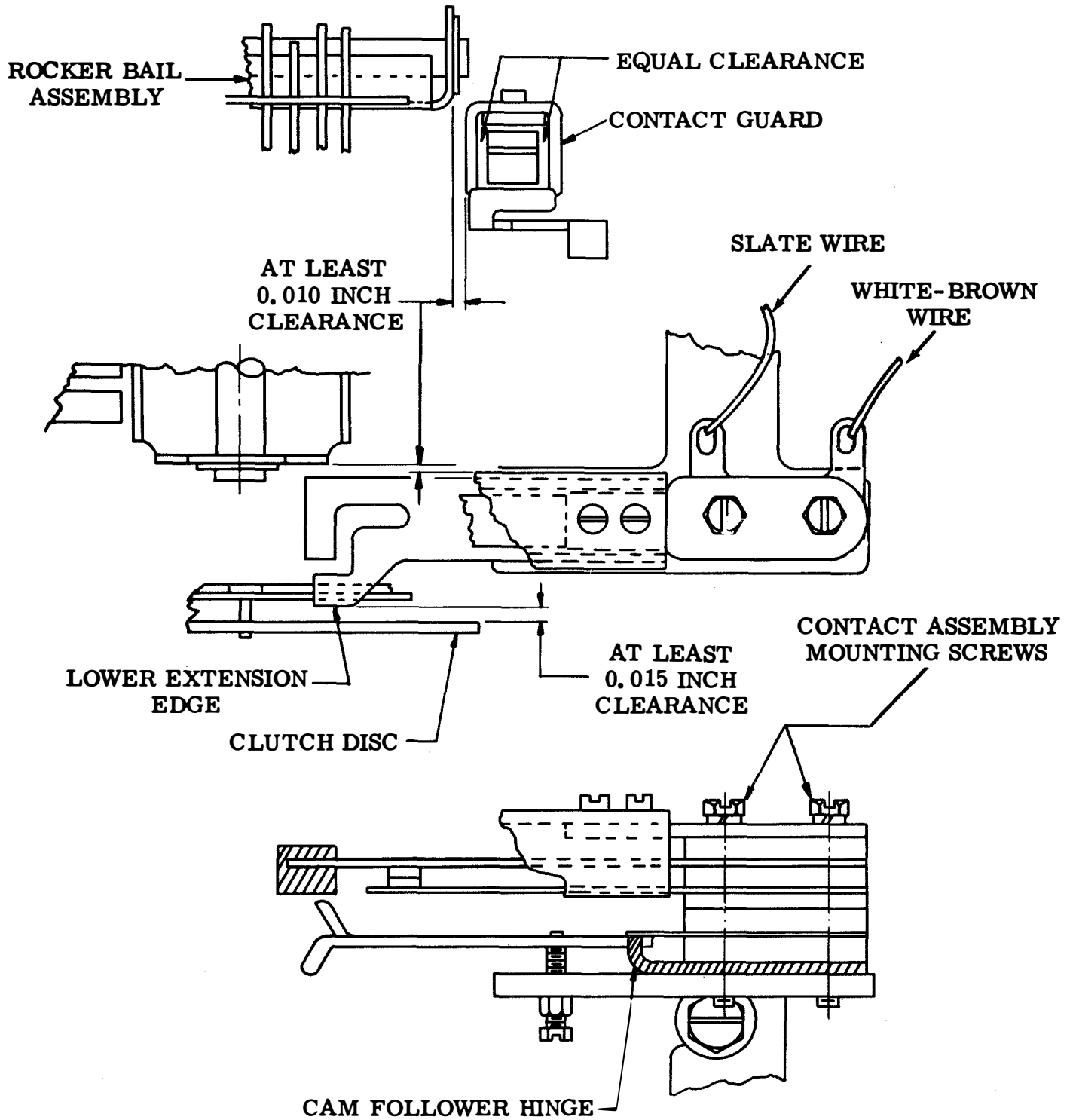

Figure 16

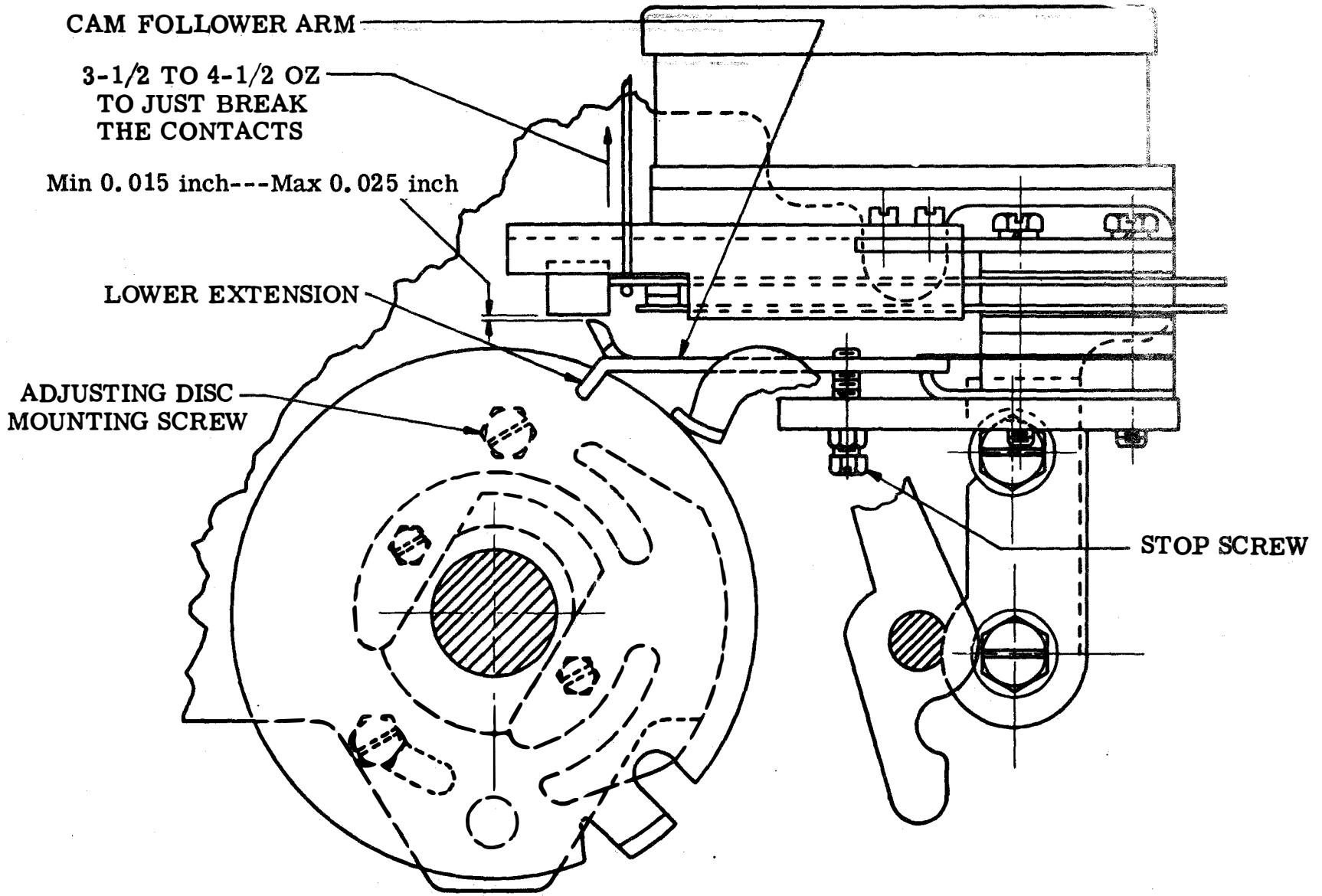
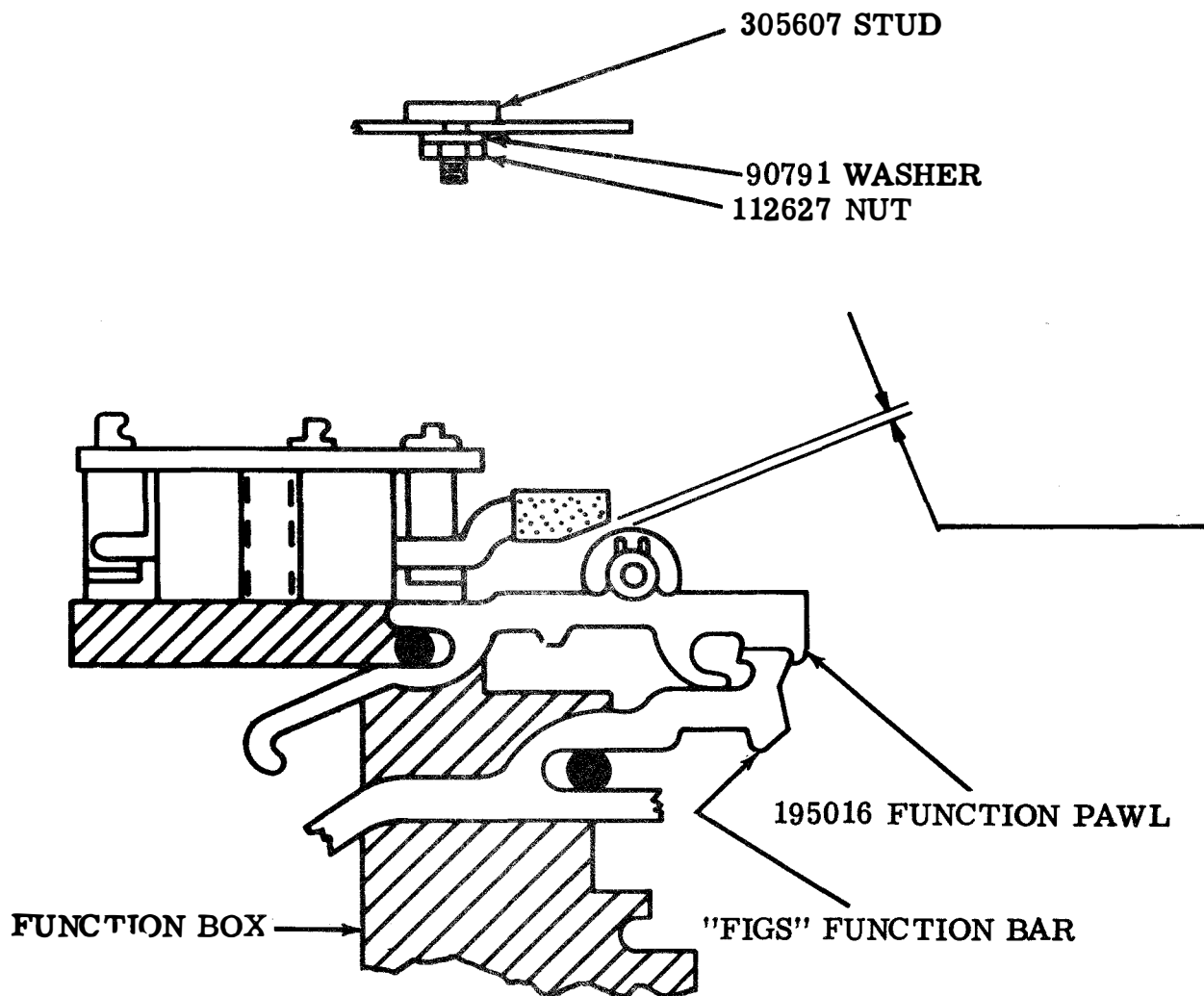

Figure 17



"FIGURES" STUNT BOX CONTACT (FUNCTION BOX SLOT 32)

**Requirement**

With stunt box on typing unit and LETTERS combination manually set up on typing unit selector mechanism, rotate typing main shaft until function pawl is in extreme forward (toward contact insulator) position as shown. There should be

Min some---Max 0.010 inch  
clearance between contact insulator and the adjusting stud.

**To Adjust**

Loosen the adjusting stud mounting nut and move adjusting stud to meet requirement. Retighten mounting nut.

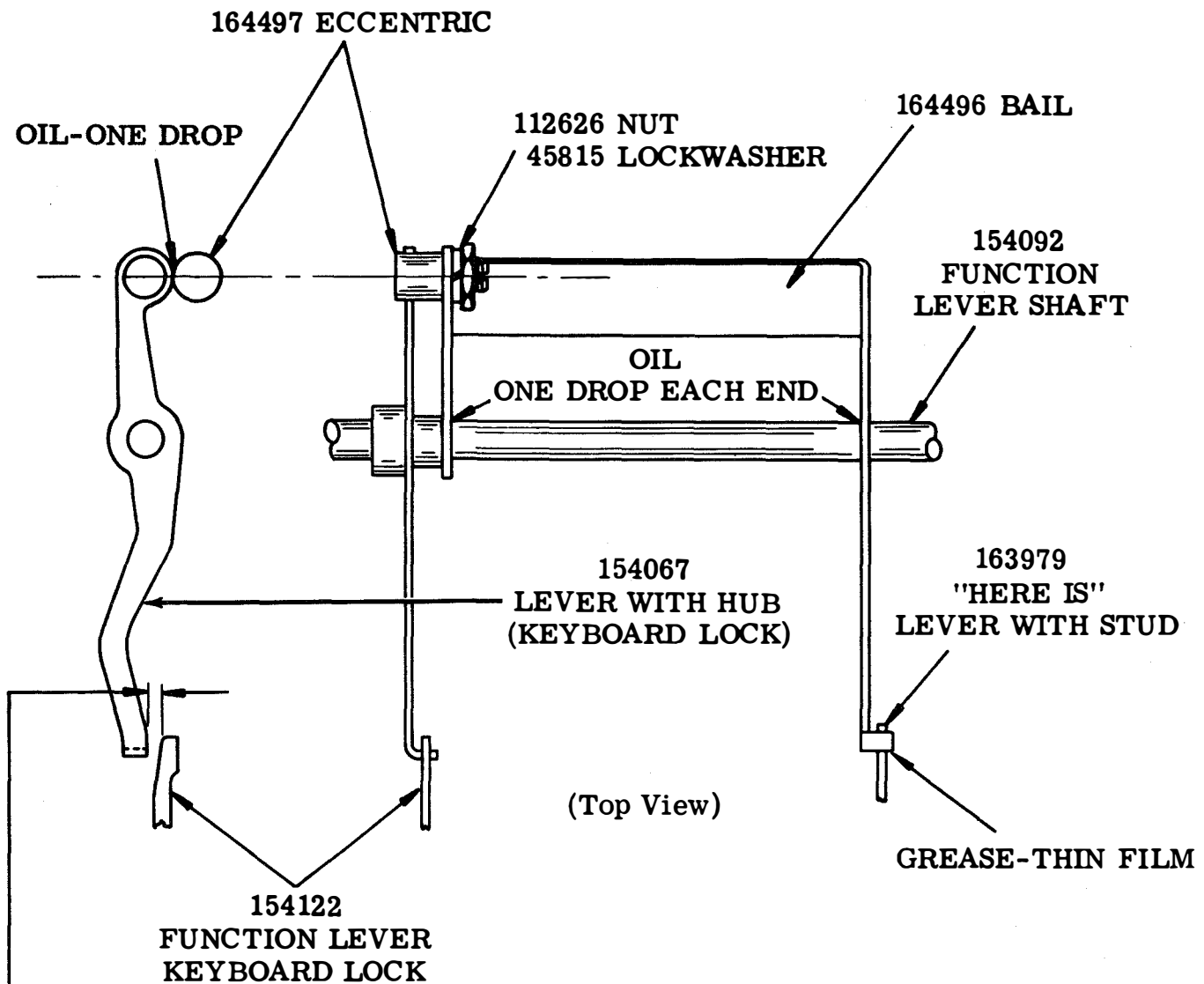

KEYBOARD LOCK BAIL ECCENTRIC ADJUSTMENT

**Requirement**

With both the **KEYBOARD LOCK** and **HERE IS** keytops lightly held fully depressed, there should be  
 Min some---Max 0.006 inch  
 clearance between the keyboard locklever with hub and the keyboard lock function lever.

**To Adjust**

Position the eccentric with its locknut loosened so that its high point is toward the front of the keyboard.

Figure 19

