

**177010 SELECTOR MAGNET DRIVER**  
FOR MODEL 28 SETS

**177015 MODIFICATION KIT TO ADD**  
**177010 SELECTOR MAGNET DRIVER**  
**TO MODEL 15 MODEL 19 SET**  
OR MODEL 20 SET

CONTENTS

SECTION 1 - DESCRIPTION  
SECTION 2 - INSTALLATION  
SECTION 3 - SERVICING  
SECTION 4 - PRINCIPLES OF OPERATION  
SECTION 5 - PARTS

1961 by Teletype Corporation

Courtesy of  
**C. Bennett Stephens**  
K9KOM

TABLE OF CONTENTS

<u>Paragraph</u>		<u>Page</u>
<b>SECTION 1 - DESCRIPTION</b>		
1-1.	General . . . . .	1-1
1-2.	Configuration . . . . .	1-1
1-3.	Features . . . . .	1-1
1-4.	Mounting . . . . .	1-2
1-5.	Technical Data. . . . .	1-2
<b>SECTION 2 - INSTALLATION</b>		
2-1.	General . . . . .	2-1
	b. Caution Notes . . . . .	2-1
	c. Input . . . . .	2-1
	d. Output . . . . .	2-1
	e. Reliability . . . . .	2-1
2-2.	Unpacking . . . . .	2-1
2-3.	Installation on Model 28 Electrical Service Unit (LESU) . . . . .	2-2
	b. Preparation of LESU . . . . .	2-2
	c. Mounting and Connecting Driver . . . . .	2-3
2-4.	Installation on Model 15 Base (BB) . . . . .	2-4
	a. General . . . . .	2-4
	b. Preparation of Model 15 BB Base . . . . .	2-4
	(1) Bases Equipped with 255A (RY30) Line Relay Mounting . . . . .	2-4
	(2) Bases Not Equipped with Line Relay Mounting . . . . .	2-4
	c. Mounting on Base . . . . .	2-4
<b>SECTION 3 - SERVICING</b>		
3-1.	General . . . . .	3-1
3-2.	Field Servicing . . . . .	3-1
3-3.	Repairs . . . . .	3-1
3-4.	Trouble Shooting Sequence . . . . .	3-1
3-5.	Replacement of Parts . . . . .	3-1
<b>SECTION 4 - PRINCIPLES OF OPERATION</b>		
4-1.	General . . . . .	4-1
	b. Terms . . . . .	4-1
	c. Signals . . . . .	4-1
4-2.	General Description of Circuits . . . . .	4-1
	a. Bias Varistors . . . . .	4-1
	b. Input Circuit . . . . .	4-1
	c. Switching Circuit . . . . .	4-1
	d. Output Circuit . . . . .	4-1
	e. Power Supply . . . . .	4-2
4-3.	Spacing Condition . . . . .	4-2
4-4.	Marking Condition . . . . .	4-2
4-5.	Space to Mark Transition . . . . .	4-3
4-6.	Mark to Space Transition . . . . .	4-4
4-7.	Blinding . . . . .	4-4
	b. Monitored Signals . . . . .	4-4
	c. Unmonitored Signals . . . . .	4-4
	d. Purpose of 50 Ohm Resistor . . . . .	4-4
4-8.	Variations . . . . .	4-5
	a. Selector Magnet Connections . . . . .	4-5
	b. Input Resistance . . . . .	4-5
4-9.	Special Modes of Operation . . . . .	4-5

SECTION 1  
DESCRIPTION

1-1. GENERAL

The Teletype 177010 Electronic Selector-Magnet Driver is a solid-state device which couples a signal line to a receiving teletypewriter and repeats the line signals in a form that will effectively operate the teletypewriter's selector mechanism. It is designed specifically to drive a single Model 28 selector magnet or a Model 15 selector holding magnet. When used in place of a line relay (such as the Western Electric 255A) to drive the specified selector magnets, it will provide improved operation, greater reliability and reduced maintenance. However, it is not intended as a general purpose driver for all types of selectors, nor as a replacement for relays in general.

1-2. CONFIGURATION (Figure 1-1)

The Driver includes a d. c. power supply and an etched circuit card which are mounted on a small chassis (Figure 1-1). The power supply consists of an isolation transformer, a full-wave rectifier and single-capacitor filter. Various electrical components including five transistors are mounted on the circuit card which is supported by three posts. Power and signal cables equipped with spade lugs provide for electrical connections to the Driver.

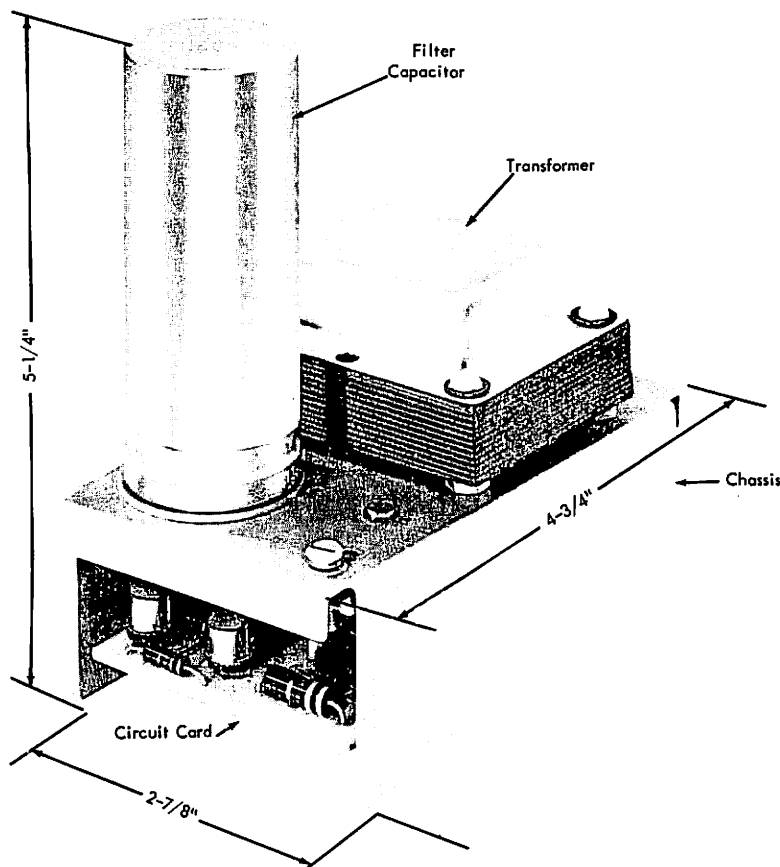

Figure 1-1. 177010 Electronic Selector - Magnet Driver

1-3. FEATURES

- a. With different strapping arrangements, the Driver will accept neutral signals of either 0.020 or 0.060 ampere or polar signals of up to 0.030 ampere. The output is 0.060 ampere regardless of input.
- b. The Driver may be strapped so that, when used in conjunction with external contacts, the selector does not receive (is blinded to) certain incoming messages and does receive (is unblinded to) others.

c. Strapping arrangements can be changed by removing and/or soldering bare wire between terminal posts on the circuit card. The posts are accessible so that the card need not be removed for this procedure.

d. Since its input is essentially resistive rather than inductive, the Driver permits the inclusion of additional receiving units on a teletypewriter loop without introducing signal distortion.

1-4. MOUNTING

a. The driver can be mounted in any vacant position on the Model 28 Electrical Service Units (LESU) and in the position provided for the line relay on the Model 15 Bases (BB). Mounting hardware is provided with the Driver.

b. When the Driver is to be placed on a Model 15 Base, the 177015 Modification Kit is required. This kit consists of the following parts:

1	176393	Cable
1	179260	Cover

c. When the Model 15 Base does not have a line relay mounting assembly, the following additional parts, as well as the 177015 Modification Kit, are required:

2	2191	Lock Washer
1	2669	Lock Washer
1	153442	Screw (10-32 x 1/2 Hex)
2	151442	Screw (6-40 x 1/2 Hex)
1	74422	Bracket

1-5. TECHNICAL DATA

DIMENSIONS (Overall)

Length .....	4-3/4"
Width .....	2-7/8"
Height .....	5-1/4"

ELECTRICAL

Power Source .....	117 v. a. c. $\pm$ 10% 50-60 cps
Max. Power Consumption .....	12 watts
Input Signals .....	0.020 a. or 0.060 a. $\pm$ 10% neutral or up to 0.030 a. polar
Output Signals .....	0.060 a.
Signalling Speed .....	Up to 200 wpm.
Wiring Diagram .....	4445WD

ENVIRONMENTAL REQUIREMENTS

Operating Temperatures .....	0° C (+32° F) to +65° C (+149° F) at specified power and input requirements
Storage Temperature .....	Max. +85° C (+185° F)

SECTION 2  
INSTALLATION

2-1. GENERAL

a. This section provides instructions for installing the Selector Magnet Driver on equipment in the field. It is important that field personnel---especially those unfamiliar with solid-state circuitry---read the caution notes in paragraph b. To mount the Driver on Model 28 equipment, refer to paragraph 2-3. below. To mount it on Model 15 equipment, refer to paragraph 2-4. Certain parts, in addition to those furnished with the Driver itself, are required to install it on Model 15 equipment as described in paragraph 2-4. a. Parts other than those in Figure 5-1 are illustrated in standard Parts Bulletins. Wiring information for standard units appears in standard wiring diagrams.

b. CAUTION NOTES

The Magnet Driver is a solid-state device, not a mechanical relay. Therefore, the procedures for its use differ from those for a relay. It should be used only as instructed in this specification. Otherwise, it may be seriously damaged. No adjustments are necessary. Tests and repairs should be made by qualified personnel only as instructed in Section 3.

c. INPUT (See Figure 4-1)

(1) The input current should be limited to specified values (0.060 a or 0.020 a). The Driver is designed to be driven by a given current---not a given voltage. Any source voltage may be used as long as enough resistance is in series with the input to ensure that the specified line current is not exceeded. For further information see paragraph 4-8. b.

(2) At full marking current of 0.060 a. or 0.020 a., the input resistance of the Driver is 48 or 145 ohms respectively. This resistance increases rapidly with decreasing current. For example, it rises to 83 and 249 ohms respectively for zero or reverse current. For further information, see paragraph 4-8. b.

(3) To avoid conflicts with existing signal line connections, the input leads of the Driver should be attached only to the signal line---not to other voltage reference points including ground. See paragraph 4-9. and 4-8. b. for further information on special applications.

(4) It is recommended that a milliammeter be placed in the line as a monitor when the line current is adjusted.

d. OUTPUT (See Figure 4-1)

(1) The output current from the Driver is 0.060 a. This current is supplied by an internal power supply and limiting resistors.

(2) No batteries (or voltages), resistors, capacitors, or other components other than the specified load should be connected to the output. The output should be connected only to a single selector magnet whose coils are in parallel. The output leads should float; i. e. they should connect only to the selector's coils, not to an external voltage including ground. If the selector coils are located at a distance from the Driver, the added resistance of the connecting wire will reduce the coil's current and consequently the selector's margin.

e. RELIABILITY - Long life and reliable operation can be expected if the Driver is used for its designed purpose within its rated limits. Otherwise, its performance may be impaired and its life reduced. Heat and voltage seriously affect the life of solid-state components. Thus the temperature and line voltage should be kept as close to specified limits (25° C and 117 v. respectively) as possible (see paragraph 1-5. ).

2-2. UNPACKING

Cut the sealed edges of the carton and unpack the Driver with care so as to not damage the solid-state circuitry.

2-3. INSTALLATION ON MODEL 28 ELECTRICAL SERVICE UNIT (LESU)

a. Following instructions apply in particular to LESU7, but are also applicable to similar units on Automatic Send-Receive and Page Printer Sets. However, because of the many variations in wiring of various coded units, check appropriate wiring diagrams to make sure connections are correct.

b. PREPARATION OF LESU

(1) If LESU is equipped with 152623, 160226 or equivalent line relay mounting assembly, proceed as instructed in paragraph 2-3. b. (2) below. If it is not equipped with line relay mounting, refer to paragraph 2-3. b. (3) below.

(2) LESU with Line Relay Mounting

(a) Location of terminal block A on LESU is shown in Figure 2-1 and on actual wiring diagram of specific unit involved. Remove leads from line relay mounting to terminal block A as follows:

<u>Wire Color</u>	<u>Circuit</u>	<u>Terminal on LESU7</u>	<u>Other LESU Units</u>
Black	120 v. d. c.	A9	Check wiring diagram.
Red	120 v. d. c.	A7	
Yellow	Signal Line	A6	
Green	Signal Line	A5	
Brown	120 v. d. c.	A3	

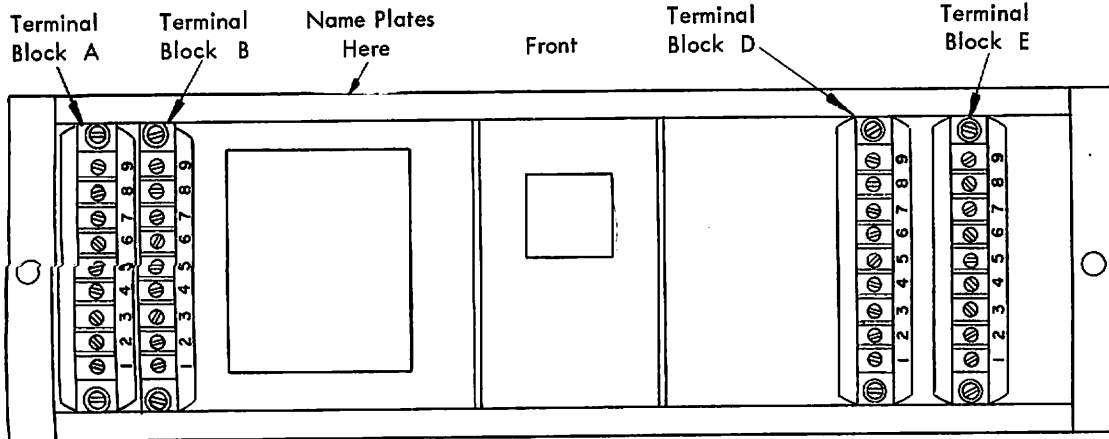

(Bottom View)

Figure 2-1. Electrical Service Unit

(b) Loosen mounting screws and remove line relay mounting assembly from LESU.

(c) Open connection between positive side of d. c. supply and selector coils. For LESU7 and related units, this can be done by removing strap between terminals C20 and C21 on terminal block C on Cabinet. On certain other units, it can be done by removing strap between A7 and A8 and connecting selector coil's lead to A7. Refer to appropriate wiring diagrams.

(d) A d. c. power supply (rectifier) on some LESUs supplies current for relay bias and selector coils. If it supplies nothing else, it may be removed. However, if it supplies line

battery, Line-Test Key etc., it should be left in place.

(3) LESU without Line Relay Mounting

(a) Open connections between selector coils and signal line. This can be done by removing straps on terminal board A (see Figure 2-1) as indicated in three typical examples below. Refer to appropriate wiring diagrams to verify these connections.

<u>LESU5</u>	<u>LESU27</u>	<u>LESU28</u>
A4 to A6	A6 to A7	A4 to A6
A3 to A7	A3 to A5	A3 to A5

(b) Loosen mounting screws and remove blank plate at position on LESU where Driver is to be mounted.

c. MOUNTING AND CONNECTING DRIVER

(1) Strap circuit card on Driver as indicated below for different types of line signals (also see Figure 4-1). Make strapping arrangements by removing and/or soldering bare wire between terminals. Driver is strapped at factory for 0.060 a. operation.

<u>Signals</u>	<u>Strapping Arrangement</u>
0.060 a. Neutral	Terminals 1 to 2 strapped; 3 to 4 open.
0.020 a. Neutral	Terminals 1 to 2 and 3 to 4 open.
0.020 to 0.030 a. Polar	Terminals 1 to 2 open; 3 to 4 strapped.

(2) Mounting hardware is furnished with Driver in two mounting slots in 178843 chassis (see Figure 5-1). Loosen two 153841 screws so that 151427 nut plates can move freely. Mount Driver in vacant position on LESU with capacitor at front. Align nut plates so they will clamp to underside of LESU's frame and tighten mounting screws.

(3) Connect leads on 178887 signal line cable (Figure 5-1) to terminal block on LESU (Figure 2-1) as indicated below. Signal line polarity must be correct.

<u>Wire Color</u>	<u>Circuit</u>	<u>Terminal on LESU7</u>	<u>Other LESU Units</u>
Yellow	+ Signal Line	A6	Check wiring diagrams.
Green	- Signal Line	A5	
Orange	Selector Magnet	A4	
Brown	Selector Magnet	A3	

(4) According to what type of control is to be used, connect leads on 178886 power cable (Figure 5-1) to terminal board E (Figure 2-1) on LESU7/152 only as indicated below. Refer to appropriate wiring diagrams for connections on units other than LESU7/152.

<u>One Wire To</u>	<u>Other Wire To</u>	<u>Type of Control</u>
E1	E9	ON Continuously
E2	E9	Power switch
E3	E9	Motor control relay

(5) Connect selector coils in parallel for 0.060 a. operation as instructed in appropriate wiring diagrams. Series connection will reduce margins and is not recommended. If series strap is present (e.g., A1 to A2 or A3 to A4 etc.), it should be removed.

(6) To blind selector to incoming signals, connect terminals 5 and 6 to positive side of

signal line through a 50-OHM, 1-watt resistor. When the original connection is restored, the Driver will again follow the line signals. An external switch or relay should be provided to make the required connections. See paragraph 4-7. for detailed information on blinding.

#### 2-4. INSTALLATION ON MODEL 15 BASE (BB)

##### a. GENERAL

(1) To mount Driver on Model 15 Base, Modification Kit 177015 (see paragraph 1-4. b.) is required. To mount it on such bases not equipped with 255A (RY30) line relay mounting, the parts listed in paragraph 1-4. c. must be ordered separately. Standard parts in Model 15 Base are illustrated in Bulletin 1037B.

(2) The Driver is designed for use with Model 15 Sets having holding-magnet selectors. It should not be used with pulling-magnet selectors.

(3) Because of variations in wiring, it is not possible to give specific instructions for each equipment. The following instructions apply to typical units. Wiring of individual units should be compared to Figure 2-2., and necessary modifications in the installation procedure should then be made.

##### b. PREPARATION OF MODEL 15 BB BASE

###### (1) Bases Equipped with 255A (RY30) Line Relay Mounting

(a) Remove all wiring from terminals 61 through 66 on upper side of signal terminal block (Figure 2-2). These wires all run to line relay mounting.

(b) Cut and tape wire that connects to terminal 64 on the lower side of the signal terminal block. Cut and tape black wire that runs between the 0.25 MF capacitor and the resistor block on line relay mounting. These two wires both connect to the 0.25 MF capacitor which is not used with Driver. This capacitor may be left in place since its removal is inconvenient. Following instructions assume that it is left in place.

(c) Disconnect and tape wire that runs between slip-connection terminal 52 and terminal 62 on lower side of the signal terminal block. Leave other wire on terminal 62. Disconnect and tape wire that connects to terminal 63 on lower side of signal terminal block.

(d) Remove 74395 relay guard or 107213 bracket, and its two 6810 mounting screws, 2669 lock washers and 3438 flat washers from 74422 bracket. Discard removed parts.

(e) Remove and discard two 74014 mounting screws, 2669 lock washers and 112626 nuts that hold relay mounting plate to the 74422 bracket.

###### (2) Bases Not Equipped with Line Relay Mounting

(a) Disconnect and tape orange wire connected to terminal 62 of signal terminal block. Move black wire from terminal 61 to terminal 62. Other wire (white) should be left on terminal 61. Remove green wire from terminal 66 and connect it to terminal 65.

(b) Mount 74422 bracket on the base using 153442 screw and 2669 lock washer and two 151442 screws and 2191 lock washers (see paragraph 2-4.a. (1) above). See Figure 2-2 for location of bracket and Figure 2-3 for location of mounting hardware.

##### c. MOUNTING ON BASE

(1) See paragraph 2-3. c. (1) above for strapping of circuit card for use with different types of line signals.

(2) Remove two 90789 flat washers and 151427 nut plates from 153841 mounting screws on Magnet Driver (Figure 5-1). Remove 153841 screws with 2191 lock washers and 7002 flat washers and slip them through threaded holes in 74422 bracket until they protrude a small amount on the other side (Figure 2-3). Place Magnet Driver on protruding screws, as shown in Figure 2-3. Install one threaded 151427 clamp plate on mounting screw. Install other plate on other screw. Tighten screws.



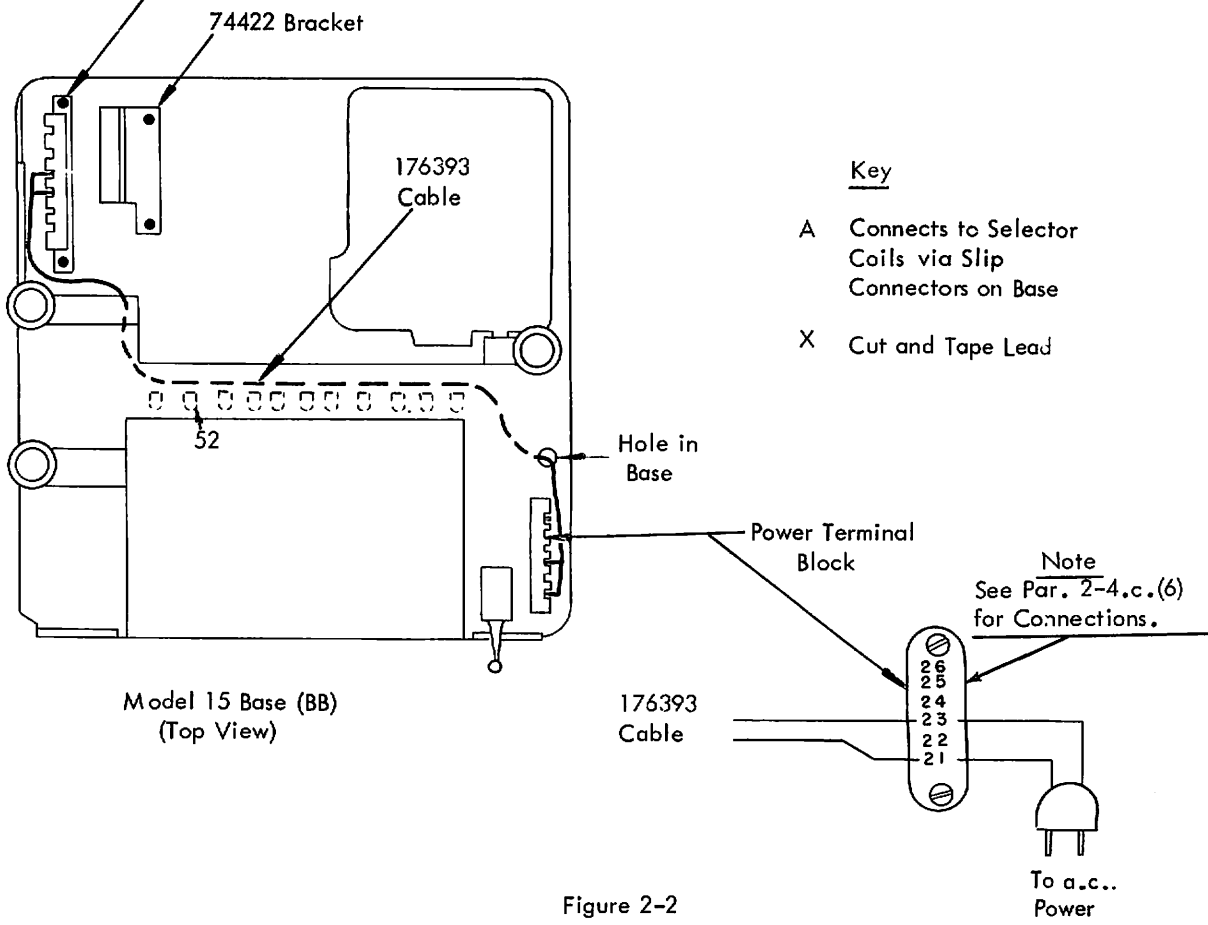
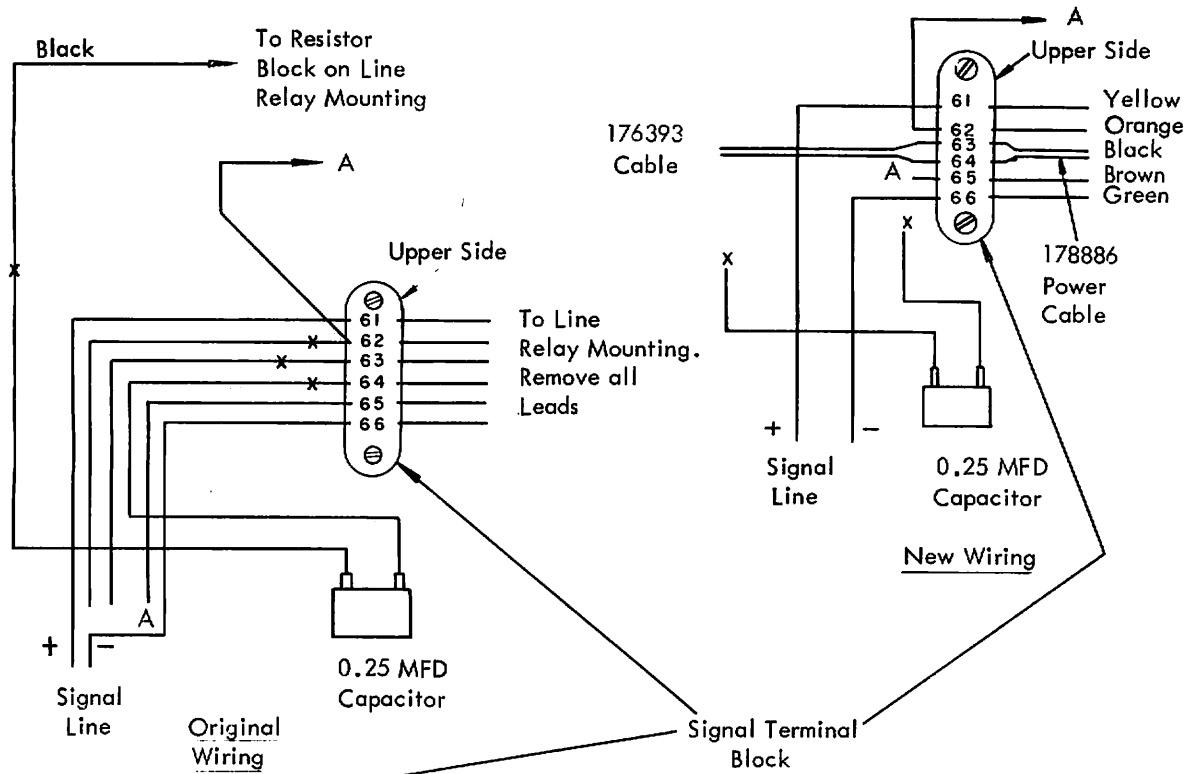

Figure 2-2

Wiring of Model 15 Base

(3) The 179260 cover (part of 177015 Modification Kit) is furnished flat, but is scored for bending. Place cover over edge of a surface such as a table top and form two end flaps (see Figure 2-3). Remove 152426 nut from upper stud, but leave 131228 insulating washer in place. Place cover as shown in Figure 2-3 with tab over stud. Replace nut and tighten. Tuck flaps inside chassis' ends.

(4) Connect leads on 178887 signal line cable (Figure 5-1) to signal terminal block (Figure 2-2) as indicated below:

<u>Wire Color</u>	<u>Terminal No.</u>	<u>To</u>
Yellow	61	+ Signal Line
Green	66	- Signal Line
Orange	62	Selector Magnet
Brown	65	Selector Magnet

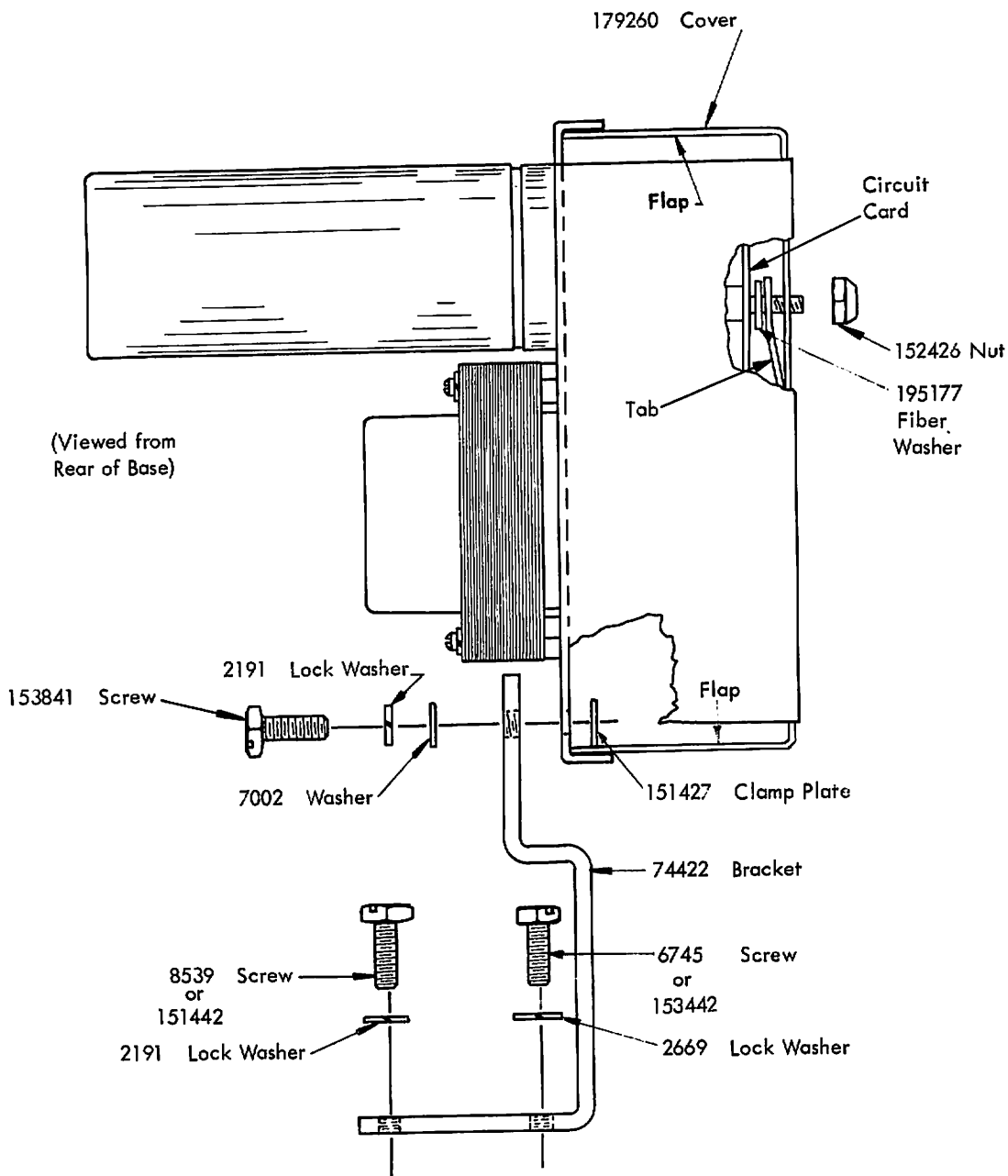

Figure 2-3. Mounting on Model 15 Base

Remove any auxiliary resistors from selector coil's circuit. Coils should be connected in parallel. Series connection is not recommended because it reduces margin.

(5) Connect black leads on 178886 power cable (Figure 5-1) to terminals 63 and 64 on upper side of signal terminal block (Figure 2-2). Tie any excess cable to terminal block's mounting bracket with lacing twine.

(6) Connect leads at one end of 176393 extension cable (part of 177015 Modification Kit) to terminals 63 and 64 on lower side of signal terminal block (Figure 2-2). Remove base plate from under side of Base by removing its mounting screws. Route 176393 cable along existing cable to power terminal block as shown in Figure 2-2. Loosen clamps holding existing cable and place 176393 cable under them. For continuous operation, connect leads on 176393 cable to terminals 21 and 23 on power terminal block. For switch controlled operation, connect leads to terminals 22 and 23. Switch control is recommended to permit turning off a. c. power to driver during maintenance periods. Replace base plate.

(7) For blinding selector to incoming signals, see paragraph 2-3. b. (6) above and paragraph 4-7.

#### NOTE

On some models of Base, a fuse and fuse block may be partially covered by Magnet Driver. If fuse is to be replaced, loosen two mounting screws and tilt Driver to one side to provide ample clearance.

This page intentionally left blank

SECTION 3  
SERVICING

3-1. GENERAL

This section covers trouble shooting and repair of the Selector Magnet Driver. General instructions appear in paragraphs 3-2. through 3-5. Tables 3-1. through 3-3. provide detailed information on locating trouble.

3-2. FIELD SERVICING

It is recommended that field servicing be limited to replacing the Driver with a spare since it is probable that suitable tools and test equipment will not be available. Replace the device upon the absence of output signal when a known input test signal of proper polarity is applied. The mere absence of an output signal does not necessarily require replacement since the trouble may be in the signal or power circuits external to the Driver. Therefore, these should be checked first.

3-3. REPAIRS

Repairs should be made at a properly-equipped maintenance center by qualified personnel. Testing and repair should preferably be handled by persons familiar with transistor circuits. The following equipment is required:

- a. A suitable source of d. c. teletypewriter signals such as a Distortion Test Set (DXD) or a Transmitter Distributor (LXD, LAXD, etc.).
- b. An oscilloscope with differential pre-amp for observing current waveforms. \*
- c. A 0-5-50 20,000 OHM-per-volt d. c. voltmeter.
- d. A 0-150 5,000 OHM-per-volt a. c. voltmeter.
- e. A 0-100 d. c. milliammeter.
- f. A selector-magnet assembly to receive Driver's output.
- g. A 1-OHM resistor in series with selector-magnet assembly to monitor selector's current waveform

3-4. TROUBLE SHOOTING SEQUENCE

To locate a trouble, proceed as follows:

- a. Check input signals for quality and correct polarity (see Tables 3-1. and 3-2.).
- b. Check output signal for absence or distortion (see Tables 3-1. and 3-2.).
- c. Check power supply's d. c. voltage (approx. -40 V).
- d. Using some sort of repetitive signal as an input, check collector of each transistor to see if it is switching, i. e., changing each time input signal changes (see Tables 3-1. and 3-2.). This should locate general circuit that has the trouble.
- e. Use Table 3-3. to determine component causing trouble.

3-5. REPLACEMENT OF PARTS

a. Resistors may be replaced by those obtained from local electronic suppliers. On the other hand, to ensure obtaining proper parts, diodes, transistors, etc. should be ordered by part number from Teletype Corporation. In an emergency, a 2N1008B transistor may be used as a replacement for any transistor on the Driver. Do not substitute diodes.

\*Note: Oscilloscope must be isolated from ground.

b. When parts are replaced, do not overheat leads of transistors or diodes, or card itself. Excessive heat will damage components and cause printed circuits to lift from board. Use a small soldering iron with a relatively low operating temperature.

## CAUTION

c. If circuit card is removed, when replacing it, place 195177 insulating washer between card and 152426 nut (see Figures 2-3 and 5-1) otherwise, nut will contact printed circuit and will cause damage to Driver.

**TABLE 3-1**  
**CIRCUIT VOLTAGES**

Location	Test Point	Input Line Condition	
		Mark	Space
Negative Signal Line	TP1	2.9 v.	0.85 v.
Q1 Base		2.7 v.	0.85 v.
Q1 Emitter	TP7 or Terminal Post #3	2.2 v.	2.2 v.
Q1 Collector	Terminal Post #5	2.2 v.	3.4 v.
Junction R4 - R5		4.3 v.	10.9 v.
Q2 Base	Terminal Post #6	2.2 v.	3.4 v.
Q2 Emitter		2.95 v.	2.95 v.
Q2 Collector	TP4	9.2 v.	3.0 v.
Q3 Base		4.15 v.	3.4 v.
Q3 Emitter		3.65 v.	3.6 v.
Q3 Collector	TP8	3.8 v.	10.9 v.
CR10 Cathode	TP5	4.6 v.	3.0 v.
Q4 Base		9.7 v.	3.4 v.
Q4 Emitter	TP4	9.2 v.	3.0 v.
Q4 Collector - Q5 Base	TP3	9.3 v.	3.1 v.
Junction R7 - R8		36.0 v.	35.0 v.
Q5 Emitter		9.85 v.	3.65 v.
Q5 Collector	TP2	39.5 v.	39.0 v.

NOTES: All voltages negative with respect to TP6.  
Nominal Power supply voltage (TP2 to TP6): 39.5 v.  
Voltage readings may vary  $\pm 15\%$  from above values.

**TABLE 3-2**  
**WAVEFORMS**

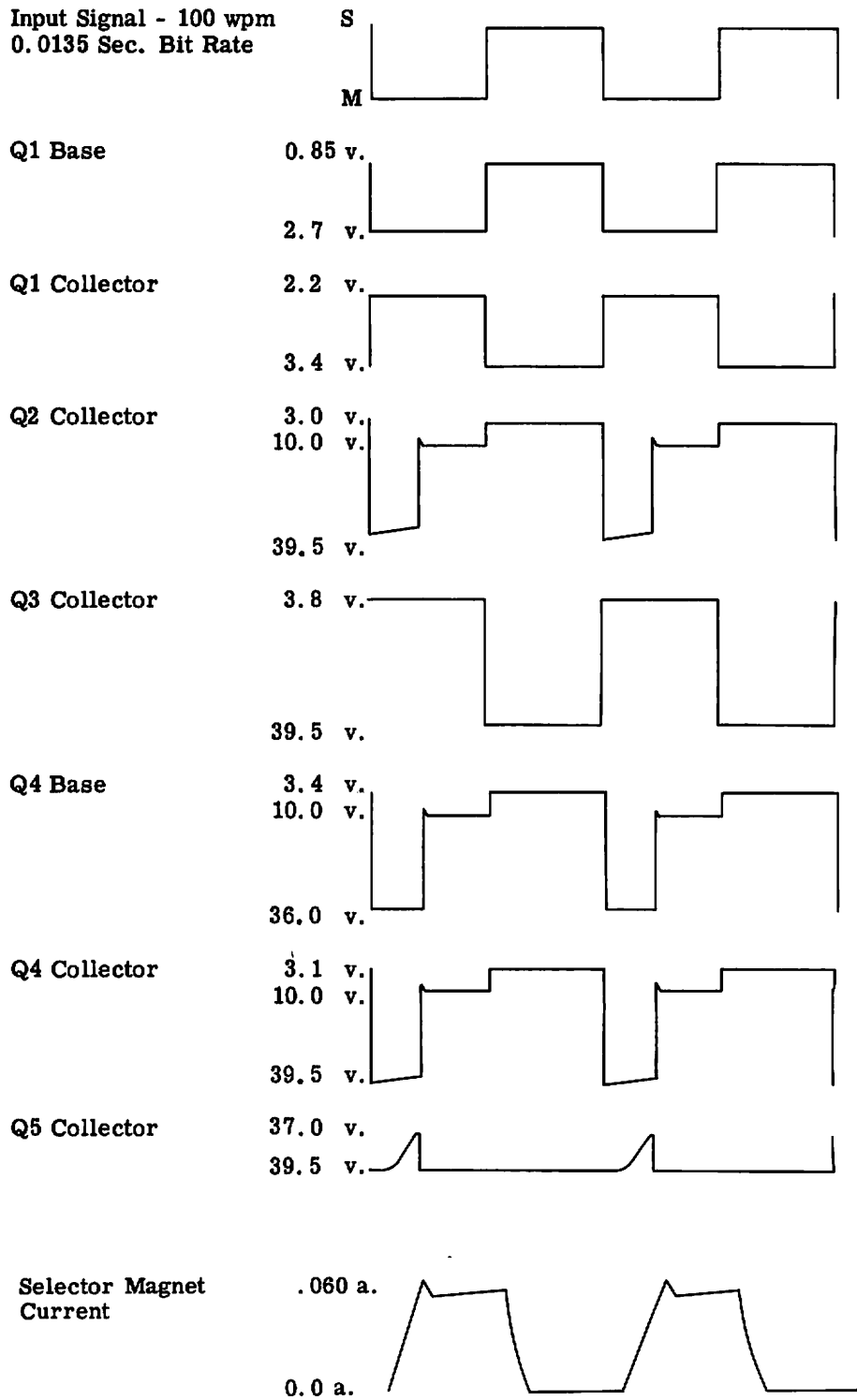

TABLE 3-3  
GENERAL TROUBLE ANALYSIS CHART

Symptom	Possible* Trouble	Confirmation**
Output remains marking despite changes in input signal.	Q1 Shorted	Q1 Collector: -2.2 v. with spacing input
	Q2 Open	Q2 Collector: -9.3 v. with spacing input.
Output remains spacing despite changes in input signal.	Q3 Shorted	Q3 Collector: -3.6 v. with spacing input.
	CR10 Shorted	TP4: -8.5 v. with marking input.
	Q1 Open	Q1 Collector: -3.4 v. with marking input.
	Q2 Shorted	Q2 Collector: -3.0 v. with marking input.
	Q3 Open	Q2 or Q3 Collector: -44 v. with marking input.
	Transformer Open	TP2: nominal d. c. voltage outside rated limits of 39.5 v. $\pm$ 5 v.
	Transformer Shorted	TP2: nominal d. c. voltage outside rated limits of 39.5 v. $\pm$ 5 v.
	C1 Shorted	Q4 and Q2 or Q3 inoperative, probably destroyed.
	C2 Open	D. c. output voltage drops to approximately 32 v. 'scope across TP2-TP6 shows pulsating d. c. (no filtering).
	C2 Shorted	TP2: d. c. output voltage drops to 0 v. Transformer, and diodes CR14, CR15 may be damaged.
	CR9 Shorted, Reversed or Open	Q3 inoperative, probably destroyed.
	CR14 or CR15 Shorted	TP2: d. c. output voltage drops very low, oscilloscope shows a. c.
	CR14, CR15 Open	TP2: d. c. voltage -35 v. with one diode open. 0 v. with both diodes open.
	CR11 Shorted	TP4: -5.1 v. with marking input.
	CR11 Reversed	TP4: -5.1 v. with marking input.
CR10 Open	TP4 and TP5: -44 v. with marking input.	
CR10 Reversed	TP4 and TP5: -44 v. with marking input.	
Q4 Open	Q5, Q2 and/or Q3 inoperative, probably destroyed.	
Q5 Shorted	Q2, Q3 and Q4 inoperative, probably destroyed.	

\* "Shorted" refers to short-circuit between emitter and collector.

"Open" refers to any pair or all three terminals open.

\*\* Voltages shown are measured with respect to TP6.



TABLE 3-3 (Continued)

<u>Symptom</u>	<u>Possible* Trouble</u>	<u>Confirmation**</u>
Garbling or loss of range	Q5 Open	Delayed current rise time in selector magnet coils. 0.010 to 0.012 sec. to reach 0.060 a. level. No overshoot current (see Table 3-2). Poor margin on spacing bias distortion.
	CR13 Open	Q5 emitter -39.5 v. with marking or spacing input. Also symptoms of Q5 open.
	Q4 Shorted	Delayed current rise time in selector magnet coils. 0.010 to 0.012 sec. to reach 0.060 a. level. No overshoot current (see Table 3-2). Poor margin on spacing bias distortion.
	CR8 Open	R4-R5 junction: -10.3 v. with marking input. Vary input current above and below 0.030 a. trigger lever. Oscillations observed when 'scope connected across one ohm sampling resistor in series with selector magnet coils. Transistors Q1 through Q5 may be damaged by this trouble condition.
	CR8 Shorted	Delayed current fall time in selector magnet coils. Approx. 0.007 sec. to reach 0 current level. Printer has poor range on marking bias signal.
	CR8 Reversed	Delayed current fall time as described above (CR8 shorted). Also, as above (CR8 open) oscillations observed.
	CR11 Open	Q3 Collector: -3.8 v. with spacing input. Delayed current fall time in selector magnet coils. 0.030 sec. to reach zero current level. Poor range on marking bias distortion.
	CR12 Open	Delayed current rise time in selector magnet coils. 0.012 sec. to rise to 0.060 a. level; no overshoot current (see Table 3-2). Poor margin on spacing bias signals.
	CR12 Shorted	Delayed current rise time in selector magnet coils; 0.012 sec. to reach 0.060 a. level; no overshoot current (see Table 3-2). Poor range on spacing bias distortion. Maximum selector magnet current 0.100 a.
	CR12 Reversed	Delayed current rise time in selector magnet coils; 0.012 sec. to reach 0.060 a. level; no overshoot current (see Table 3-2). Poor range on spacing bias signals. Maximum selector magnet current 0.100 a.
CR14 or CR15 Open	D. c. voltage at TP2 decreases below 39.5 v. -15%. Maximum selector magnet current approximately 0.040 a. Poor range on spacing bias signals.	
C2 Open	TP2: Low d. c. output volts; high ripple voltage; poor overall range.	

\* "Shorted" refers to short-circuit between emitter and collector.  
 "Open" refers to any pair or all three terminals open.  
 \*\* Voltages shown are measured with respect to TP6.

This page intentionally left blank

## SECTION 4 PRINCIPLES OF OPERATION

### 4-1. GENERAL

- a. This section explains the operation of the Selector Magnet Driver. It is based on the schematic wiring diagram in Figure 4-1. Basically the Driver operates as follows: Neutral or polar teletypewriter signals are applied to its input. These signals are repeated at its output in a form that will effectively operate the selector of a receiving teletypewriter. Direct current for the Driver's circuits is provided by an internal power supply.
- b. **TERMS** - The transistors as used in the Driver either do not conduct or conduct into saturation. They do not operate at intermediate stages. Thus throughout this discussion they are referred to as being either "on" (conducting) or "off" (not conducting).
- c. **SIGNALS** - The Driver is specifically designed to receive teletypewriter, start-stop signals. These signals are explained in detail in Teletype descriptive bulletin 216B, 242B, 246B, etc. For this explanation, it is sufficient to say that each signal element (or pulse) may occur in either of two conditions---marking or spacing. For neutral operation, current flows in the signal line circuit during the marking condition, and no current flows during the spacing condition. For polar operation, current flows during both conditions, but the polarity is reversed to differentiate between marking and spacing.

### 4-2. GENERAL DESCRIPTION OF CIRCUITS

a. **BIAS VARISTORS** - The elements referred to as "bias varistors" (CR1 through CR5) are used in the circuit to develop transistor bias voltages and low-voltage references that set the input switching level. They consist of two diffused-junction, silicon diodes mounted in opposite directions side by side. They have a forward diode characteristic in either direction and thus their voltage drop varies slightly with the current. At 0.10 a. the drop is 0.8 v. Stabistors CR6, CR7 and CR13 have characteristics similar to varistors, but pass current in only one direction.

#### b. **INPUT CIRCUIT**

(1) The input circuit receives the teletypewriter signals and determines when the Driver shifts from marking to spacing. It includes R1 through R3, bias varistors CR1 through CR5, and transistor Q1. In neutral operation, it keeps the Driver spacing or marking until the line current rises above or drops below the switching value. In polar operation it does the same until the current rises above or drops below zero.

(2) Resistor R1 protects transistor Q1 from high current surges that might damage it. It samples the current flowing into Q1's base, and, if the current exceeds a value of approximately 0.100 a., the voltage developed across R1 and the base-emitter junction exceeds the forward drop of CR1 and CR2, and most of the excess current is shunted around Q1. Since the bias varistors are bi-directional, Q1 is protected for inputs of either polarity.

(3) For 0.020 ampere neutral operation, R2 is disconnected by removing the strap at terminals 1 and 2, and R3, CR3, CR4 and CR5 are left in the circuit. For 0.060 ampere neutral operation, R2, R3, CR3, CR4 and CR5 are all left in the circuit (as shown in Figure 4-1.). For polar operation up to 0.030 a., R2 is disconnected by removing the strap at terminals 1 and 2; CR3, CR4, and CR5 are shunted out by placing a strap across points 3 and 4; and R3 alone is left in circuit.

c. **SWITCHING CIRCUIT** - Transistors Q2, Q3 and associated components form a snap-action trigger circuit. In the marking condition, Q2 is off and Q3 is on. The opposite exists for the spacing condition. The change from one state to the other occurs at the midpoint value of the input current and is very rapid regardless of the slope of the input wave form.

d. **OUTPUT CIRCUIT** - The output circuit, which includes Q4, Q5 and associated components, controls the current in the selector magnet coils. During the space to mark transition, it places essentially the full supply potential across the coils and causes the current to rise rapidly to the operating value of 0.060 a. This rapid rise provides quick selector armature pick-up. Once the operating value is reached, the circuit adds resistance to maintain the operating current. During the mark to space transition, a controlled discharge circuit, which includes CR9 and Q2, rapidly

dissipates the coil's energy without developing any high reverse voltage transients that might cause transistor damage.

e. **POWER SUPPLY** - The power supply provides d. c. for the Driver's circuits. It includes an isolation transformer, a full-wave rectifier, and single capacitor filter. It operates from a 117 v., 50-60 cps, a. c. source, and provides a nominal d. c. voltage of -40 v. This value provides a safety factor against transistor breakdown under the most unfavorable circumstances of high temperature, high line voltage and maximum line signaling frequency.

#### NOTE

The actual potential of the negative side of the power supply relative to ground depends on where the signal line is grounded. Relative to the local earth ground, it can have almost any value in the range of +120 v. to -120 v.

#### 4-3. SPACING CONDITION

a. In the spacing condition transistors Q1, Q3 and Q5 are off; Q2 and Q4 are on; and no current flows in the selector magnet coils.

b. In neutral operation, no current flows in the signal line during spacing. Thus, the base of Q1 is connected to the positive side of the power supply either through R3 alone (for 0.020 a. operation) or through R3 and R2 in parallel (for 0.060 a. operation). Internal current through varistors CR3, CR4 and CR5 places a -2.4 v. bias on the emitter of Q1 and keeps it off. In polar operation (R3 alone in circuit and CR3, CR4 and CR5 shunted), TP1 is positive and TP6 is negative during spacing. Thus the signal line through R1 drives the base of Q1 positive and keeps it off.

c. The base of Q2 is driven negative with respect to its emitter through resistors R4 and R5 and resistors R7 and R8. Thus Q2 is on, and the voltage drop from its emitter to collector is very small---less than 0.1 v.

d. The output of Q2 is applied to the base of Q3 through germanium diode CR11. The current flow through CR11 and R6 to the negative side of the power supply causes a maximum drop of 0.4 v. across CR11. Thus the base of Q3 is at most -0.5 v. with respect to the emitter of Q2. Resistor R12 permits sufficient current to flow through CR7 that the latter's voltage drop is at least 0.6 v. Q3's emitter is more negative than its base; thus Q3 is off.

e. CR10 prevents current from flowing from the collector of Q2 through the selector coils, CR8 and R4 to the negative side of the power supply. Therefore, the selector magnet is not energized in the spacing condition.

f. The collector of Q2 is connected to the emitter of Q4 and to one side of CR13. The negative side of the power supply through R9 makes the base of Q4 negative in relation to its emitter and keeps it on. A 0.1 v. drop across Q4 is applied to the base of Q5. Because of the voltage drop across CR13 caused by the current flow through CR13 and R13, the emitter of Q5 is at least 0.55 v. more negative than the emitter of Q4. Thus there is a 0.45 volt back bias across Q5 which remains off.

#### 4-4. MARKING CONDITION

a. In the marking condition, Q1, Q3 and Q4 are on; Q2 and Q5 are off; and a current of 0.060 a. flows in the selector magnet.

b. In both neutral and polar operation, the marking signal places a negative potential on the base of Q1 and keeps it on. Current flows from its collector to the negative side of the power supply through R5 and R4 and through R8 and R7. Current also flows through CR6, CR7 and R12 to the negative side of the supply. A drop of at least 0.65 v. across CR6 is applied to the emitter of Q2. The base of Q2, which is connected directly to the collector of Q1, is about -0.1 v. with respect to the emitter of Q1. Therefore, Q2 has a back bias of 0.55 v. and is off.

c. Since Q2 is cut off, it does not back bias Q3 as it did in the spacing condition (paragraph 4-3. d.). The negative side of the supply through R6 puts a negative potential on the base of Q3 and keeps Q3 on. Current flows from the collector of Q3 through CR8 and R4 to the negative side of the supply, and through CR10 and the selector coils to the junction of Q4's emitter and CR13. Since the

base of Q3 is only about -0.4 v. with respect to its emitter, the drop of almost 5 v. across Q3, CR10, and the selector coils back biases diode CR11. Q2 is unaffected since it is off and its collector is negative with respect to its base.

d. Q4 is on and Q5 is off as described in paragraph 4-3. f. above.

#### 4-5. SPACE TO MARK TRANSITION

a. In neutral operation, varistors CR3, CR4 and CR5 places -2.4 v. on Q1 keeping it turned off during spacing (paragraph 4-3. b.). As the signal line changes from spacing to marking, current begins to flow in the input line and a negative potential is developed across the input resistor(s) (R3, or R3 and R2). Q1 remains off until this current exceeds its mid-point value of 0.010 a. for 0.020 a. or 0.030 a. for 0.060 a. operation. This mid-current value is detected when a voltage slightly greater than -2.4 v. is developed at the base of Q1 turning it on.

b. In polar operation R3 alone is in circuit and CR3, CR4 and CR5 are shunted. As soon as the current moves slightly beyond zero in the marking direction, it places a negative voltage on the base of Q1 and turns it on.

c. Q3 turns on, and Q2 turns off under the conditions described in paragraphs 4-4. b. and c. above. Q2 and Q3 form a trigger circuit which utilizes positive feed back. The collector of Q2 is connected to the base of Q3, and the collector of Q3 is connected to the base of Q2. Q2 through CR11 switches Q3, and Q3 then feeds back to Q2 through CR8 controlling the resistor network of R4 and R5. As the signal changes from spacing to marking, Q1 turns on and causes Q2 to begin to turn off. Q2 in turn causes Q3 to begin to turn on. The collector of Q3 drives the junction of R4 and R5 positive. Less base current is supplied to Q2 which turns off even more. This trigger action removes any point of uncertainty and prevents the Driver from being damaged by locking up on an intermediate point or going into oscillation as the input switching level is crossed.

d. Initially, the induced voltage of the magnet coil opposes the current flow from the collector of Q3 through the coils to the negative side of the supply. This prevents current from flowing through CR13 and Q4 (which was on during spacing). The collector of Q4 and the base of Q5 move toward the negative supply potential. Q5 is off and its collector is at the negative supply potential. Since its base and collector are negative, the emitter of Q5 also moves toward the negative supply potential.

e. A short time later, the voltage drop across the coils decreases, and current begins to flow in the coils, increasing nearly linearly with time. The negative terminal of the coils begins to move toward the positive supply potential. The emitters of Q4 and Q5 begin to go positive. Since the negative potential on the collector of Q4 is applied to the base of Q5, the latter turns on as its emitter goes positive and Q4 turns off.

f. Since R11 is small and Q5 is on, essentially the full supply potential is placed across the coils. The coils' current, limited only by R11 and the small resistance of the coil, increases rapidly. (It aims at point much higher than the desired 0.060 a. operating current.) Thus the operating current is reached very quickly, and effects a fast pickup of the selector magnet armature.

g. During the spacing condition, Q4 was on and its base was no more than -0.6 v. with respect to its emitter. As described above, during the space to mark transition, the current flow through Q4 drops to almost zero, and its emitter goes toward the negative supply potential. Capacitor C1 holds Q4's base at the conducting potential which is positive with respect to the emitter, and Q4 turns off. Q5 is still on. The base potential of Q4 drops exponentially toward the negative supply as C1 discharges through R9.

h. Normally the voltage divider network of R7 and R8 places a potential of +10 v. with respect to the negative supply on the anode of CR12 which is back biased. However, during the space to mark transition period, the base potential of Q4 drops exponentially toward the negative supply. When it gets just below the divider's voltage, CR12 becomes forward biased and clamps the base to this value.

i. As the current begins to flow through the coils, Q4's emitter drops from the negative supply potential until it is more positive than its base, and Q4 turns on. Its collector potential becomes nearly the same as its emitter and is applied to the base of Q5 which turns off. CR12 is again back biased, and the current to Q4's base is supplied through R9 as before. The current flow from

the coil to the negative supply is now through Q4 and R10 which limits it to the operating value of 0.060 a. R9 and R13 are essentially in parallel with R10 and help to determine the current's value.

j. The voltage divider network of R7 and R8 determines the current value at which Q5 turns off and Q4 turns on. The closer the potential on the anode of CR12 approaches the negative supply, the sooner Q5 turns off. Current through the divider network always flows to the positive side of the supply either through the collector of Q1 or the base of Q2. CR12 remains back-biased except for the brief period described above during the space to mark transition.

#### 4-6. MARK TO SPACE TRANSITION

a. As the signal changes from marking to spacing, Q1 and Q3 turn off and Q2 turns on under the conditions described in paragraph 4-3.b. through e. above. The operation of the trigger circuit of Q2 and Q3 is the opposite of that described in paragraph 4-5.c. Q4 remains on and Q5 remains off as described in paragraph 4-3.f.

b. When Q3 turns off, it no longer supplies current to the selector coils. The coils resist a drop in their current by developing a negative voltage transient at their normally positive end. This transient is passed by CR10, blocked by CR8 and blocked by CR9 until it exceeds the negative supply potential at which time CR9 conducts. CR9 insures that the voltage rating of Q3 is not exceeded by clamping it at about -40 v.

c. Q2 holds the normally negative end of the coil at near positive supply potential when Q3 turns off. A constant potential of about 35 v. is thus placed across the coils. The rate at which the current through the coil decreases is constant.

#### 4-7. BLINDING

a. A receiving teletypewriter is "blinded" when it does not respond to the line signals, i. e. it does not print or perforate the information being transmitted on the line. To effect blinding, the selector is kept steadily marking regardless of the line signals. Blinding can be accomplished in a number of ways depending on the specific application, but may be considered in two categories based on whether or not it is necessary to monitor the signal line while the equipment is blinded.

##### b. MONITORED SIGNALS

(1) If it is necessary to monitor the line signals, the Driver can be blinded as follows. The collector of Q1 is disconnected from the base of Q2 by removing the strap between terminals 5 and 6. Terminal 6 is then connected (by relay contacts etc.) to the positive side of the power supply at terminal 4 through a 50 OHM resistor (see Figure 4-4.a.). Because of the drop across CR3, CR4, CR5, CR6 and CR7, a back bias of about 3.2 v. is placed on Q2. Thus Q2 is off, Q3 is on, and the Driver is locked in the marking condition regardless of the line signals (see paragraph 4-4). By auxiliary circuits not part of the Driver, the line signals can still be monitored at terminal 5. Normal operation of the Driver can be restored by externally reconnecting terminals 5 and 6 and disconnecting the 50 OHM resistor between terminal 6 and the positive side of the power supply.

(2) Blinding can be accomplished either manually or automatically. For example, the stunt box of a Page Printer (which would be receiving the line signals through its own selector) could be arranged so that its contacts would blind the Driver of a Reperforator at the receipt of a certain character sequence, and would unblind it at the receipt of another sequence. Thus the Reperforator could be made to ignore certain traffic.

##### c. UNMONITORED SIGNALS

(1) If it is not necessary to monitor the line signals, a simpler method of blinding may be used. Terminal 6 is connected to the power supply (signal line) at terminal 4 through a 50 OHM resistor and the strap between 5 and 6 is not removed (see Figure 4-4.b.).

(2) This approach is feasible providing that the reduced input resistance will not disturb external circuits that operate into the Driver.

##### d. PURPOSE OF 50 OHM RESISTOR

The 50 OHM 1 watt resistor connected between terminals 6 and 4 prevents damage to Q1 in the event the signal line current exceeds the value for which the input resistors are strapped.

#### 4-8. VARIATIONS

a. **SELECTOR MAGNET CONNECTIONS** - The circuits of the Driver are designed for connecting the two selector coils in parallel to reduce required d. c. voltage and to reduce the overall self-induced voltage when the coils' current is increasing or decreasing. Operation with the coils in series will not harm the Driver, but will reduce signal margins. It is not recommended. A typical parallel connection is shown in Figure 4-3.

#### b. **INPUT RESISTANCE**

(1) For the signal line, the input resistance of the Driver varies in accordance with the polarity and magnitude of the input current. For example, the input resistors of 124 and 249 ohms are in parallel for 0.060 a. operation and have an effective measured value of 83 ohms. This is the input resistance for the signal line as long as the line current is below the switching level, i. e. the level where Q1 turns on (0.030 a.)

(2) When Q1 does turn on, however, the voltage across the 83 ohms is held at approximately 2.9 v. by the clamping action of Q1, CR3, CR4 and CR5 even though the current is increasing. Thus the resistance is decreasing: e.g. at 0.060 a. the actual effective value is 48 ohms, or about one half of the measured value of 83 ( $2.9 \text{ v.} / 0.060 \text{ a.} = 48 \text{ ohms}$ ). The corresponding effective resistance for 0.020 a. operation is 145 ohms.

(3) This variation in input resistance can lead to discrepancies between the computed and actually required values of signal line series resistance. For example, assume a ten-station teletypewriter loop, 0.060 a. operation, 120 v. line battery, and ignore the resistance of the signal line itself. Basing the values on ohmmeter or bridge measurement, the total resistance in the circuit would thus be  $83 \times 10$  or 830 ohms. The total required resistance would be  $120 / 0.060$  or 2000 ohms. The battery station would thus require 2000-830 or 1170 ohms of series resistance. However, in light of paragraph 4-8. b. (2) above, actually the effective value of the input resistance at the marking current value is approximately one-half of the measured value, or 480 ohms. If 1170 ohms, as computed above, is used at the battery station, the total effective line resistance will be  $1170 + 480$  or 1650 ohms, and the resulting line current will be  $120 / 1650$  or 0.073 a. Thus the series resistance actually required at the battery station to give 0.060 a. of line current is 2000-480 or 1520 ohms.

(4) If line resistance is checked with line current of reversed polarity as in polar operation, a similar discrepancy appears. Since Q1 does not conduct when the polarity is reversed, the input resistance seems to be higher. Consequently, it is difficult to obtain equal current for marking and spacing on polar circuits, unless each is set independently of the other.

(5) With the Driver strapped for polar operation, the computed input resistance for marking is  $R1 + (0.4 \text{ v.}) / 0.030 \text{ a.}$  or  $10 + 13.3 = 23.3$  ohms. (0.4 v. is the Q1 emitter to base drop). For spacing, the computed input resistance is 1.6 v., the drop across CR1 and CR2, divided by 0.030 a. or 53 ohms.

#### 4-9. SPECIAL MODES OF OPERATION

a. The drivers are designed to operate in the conventional manner with their inputs in series. Paralleling the inputs of several Drivers is not recommended, because the first to go marking holds the input voltage at its threshold value and prevents it from rising higher to turn on the other Drivers. However, several modifications of the input circuit can be made to meet special requirements.

b. Parallel operation is often used to permit several circuits to be operated from a single keyer, although series operation can usually accomplish this end. When conditions make parallel operation desirable---as in hub circuits---additional circuitry must be provided to isolate the Drivers from each other. Resistors can be used for this purpose as shown in Figure 4-2. a., or diodes as shown in Figure 4-2. b.

c. The input terminals can be shorted to make the Driver go spacing. CR1 and CR2 are placed in parallel with CR3, CR4 and CR5. Since CR1 and CR2 have a lower voltage drop, all the current flows through them to the emitter of Q1 instead of through CR3, CR4 and CR5. The resultant voltage drop through CR1 and CR2 applies a negative bias to the emitter of Q1 which keeps Q1 shut off.

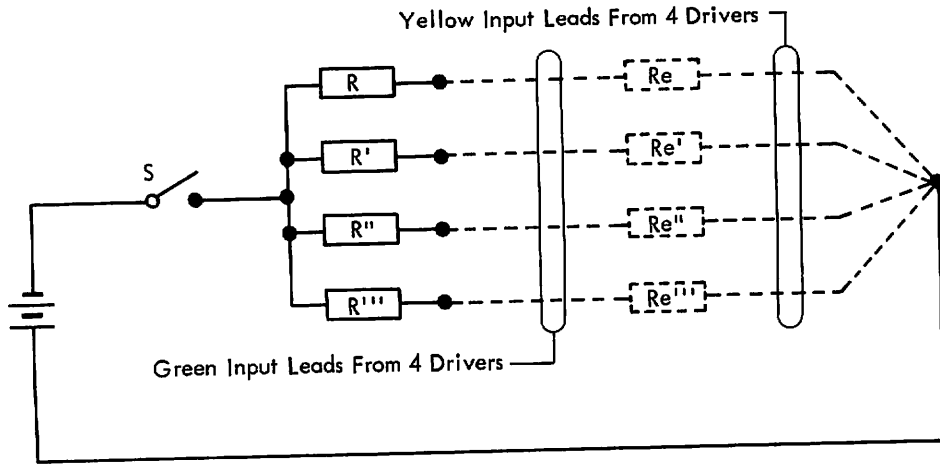

a. Isolation with series Resistors.

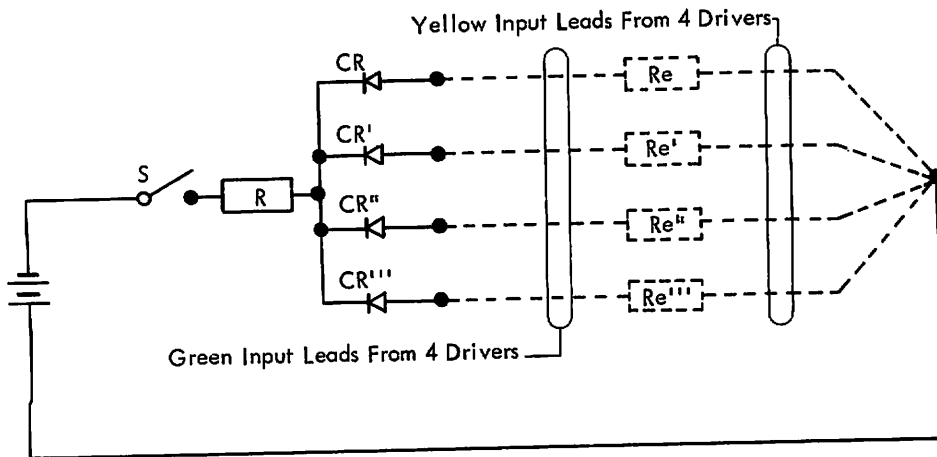

b. Isolation with Diodes.

- R, R', R'' & R''' - Current Limiting Resistors
- Re, Re', Re'', Re''' - Drivers' Equivalent Input Resistance.
- CR, CR', CR'' & CR''' - Isolation Diodes
- S - Keying Contacts

Circuitry that is part of Driver is shown in broken lines. Additional Circuitry is shown in solid lines.

Figure 4-2. Additional Circuitry for Parallel Operation of Four Drivers.



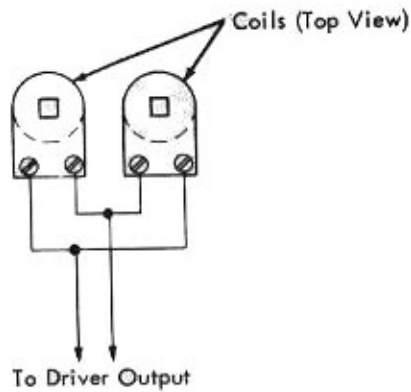

Figure 4-3. Selector Coils Connected in Parallel

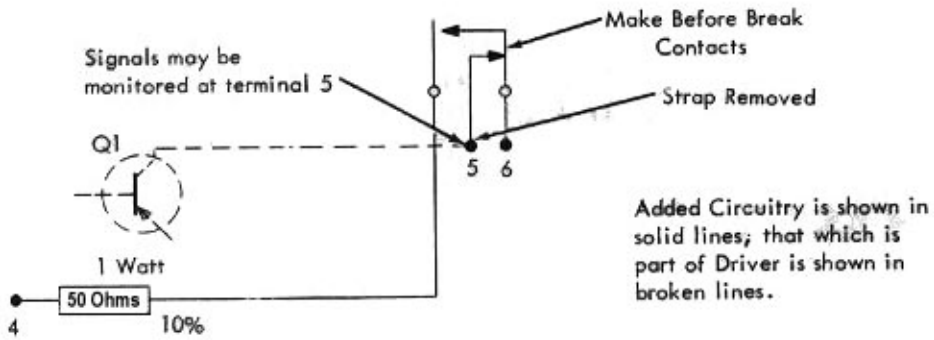

Figure 4-4.a. Blinding Arrangement to Permit Signal Monitoring

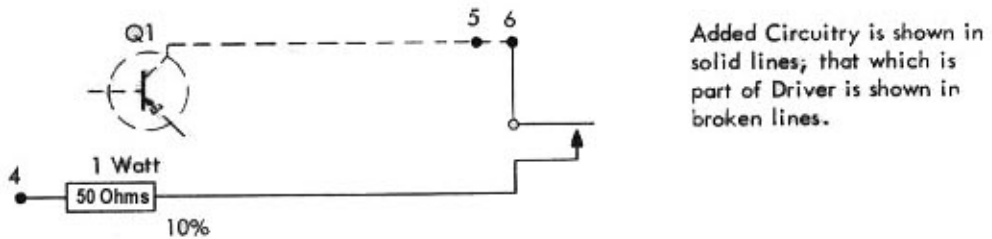
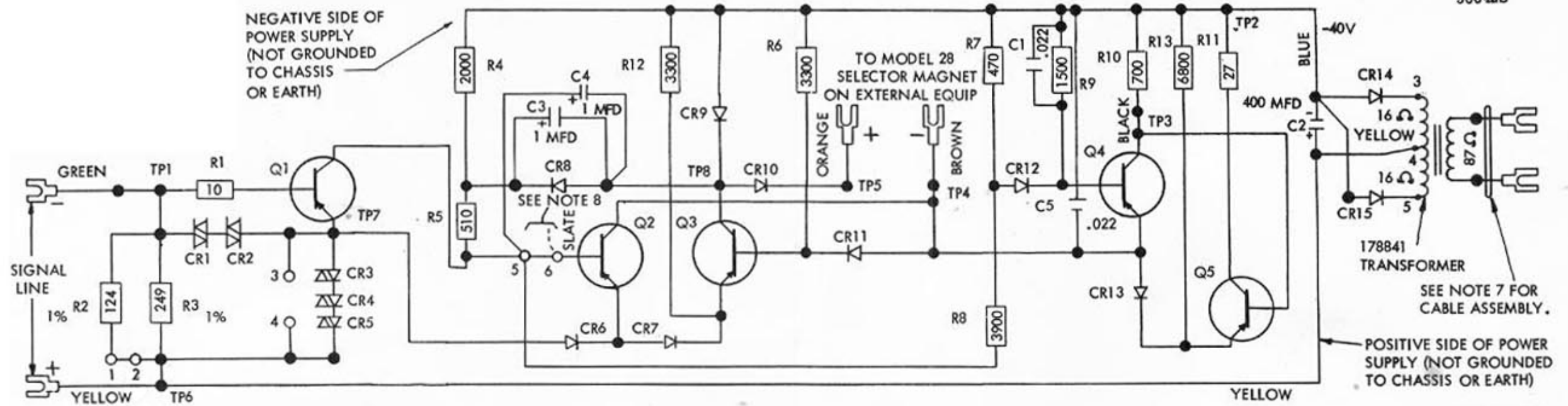

Figure 4-4.b. Simple Blinding Arrangement

This page intentionally left blank



- NOTES
- Units wired for 117V 50/60cycle operation only.
  - Selector coils in parallel for all conditions of operation.
  - Strapping for input options:  
 .020 Amp. neutral operation:  
 1-2 Open 3-4 Open  
 .060 Amp. neutral operation:  
 1-2 Strapped 3-4 Open  
 .020 to .030 Amp. polar operation:  
 1-2 Open 3-4 Strapped
  - For normal operation terminals 5 & 6 are strapped. To "blind" the selector (steady marking condition), connect terminal 6 to positive side of power supply through 50-ohm resistance and auxiliary control contacts. See specification for further details.
  - Factory Strapping: 1-2, 5-6.
  - All resistors 5% tolerance unless otherwise indicated.
  - Associated Cables:
 

Used On	Used On
178886	177010
178887	
178602	178601*
  - When installing 178602 Cable Assembly, connect slate lead to terminal 6.  
 \*For use as a reperforator control in an ASR Set.

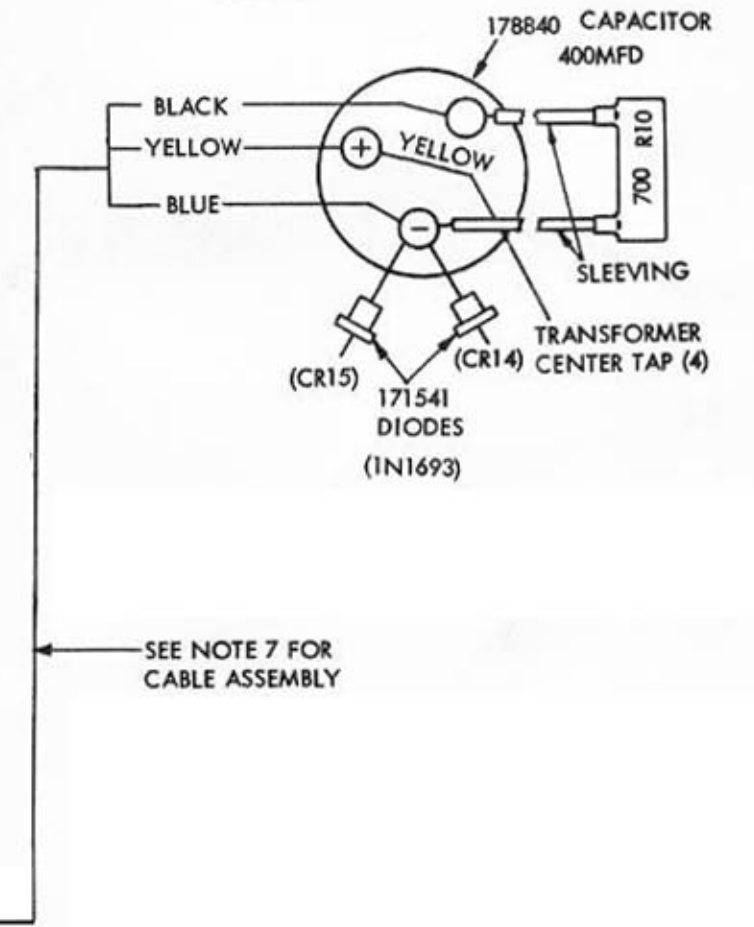
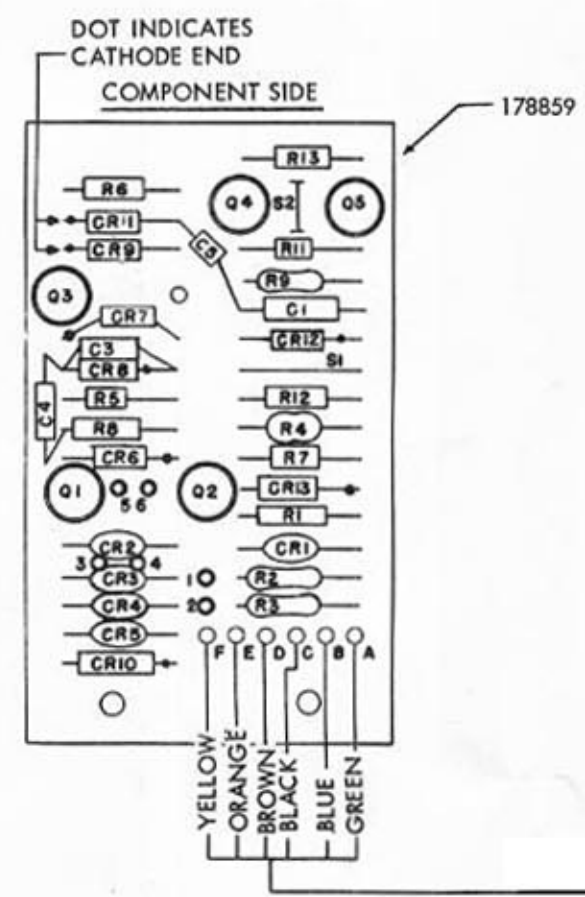
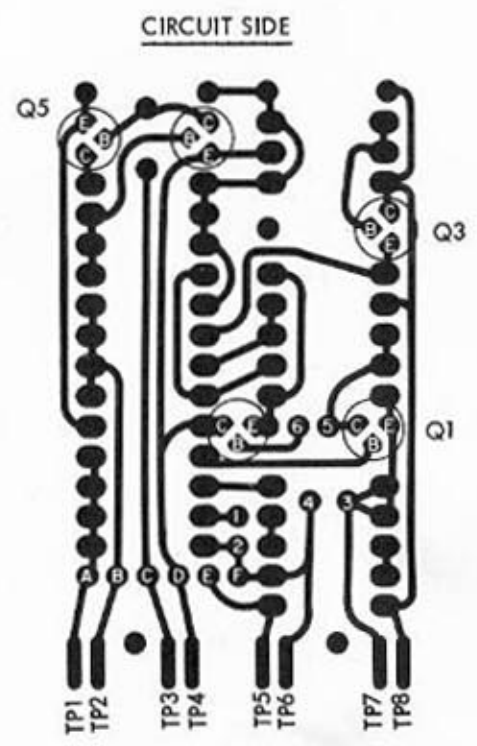

9. On earlier versions of Driver, CR6, CR7, & CR13 are same as CR1.

Figure 4-1. Schematic and Actual Wiring Diagram of Selector Magnet Driver

5-1  
50042S

SECTION 5

PARTS

<u>Part Number</u>	<u>Description</u>
2191	Washer, Lock
6345	Nut (6-32 Hex)
7002	Washer, Flat
90789	Washer, Flat
121243	Clamp, Cable
131228	Washer, Insulating
151427	Plate, Clamp
151626	Terminal
151629	Nut (6-40 Spl)
151630	Screw (6-40 x 1/4 Hex)
152426	Nut (6-40 Hex)
153841	Screw (6-40 x 9/16 Hex)
171541	Diode (IN1693)
176393	Cable Assembly
177015	Modification Kit to Add 177010 Selector Magnet Driver to Model 15 or Model 19 or Model 20 Set
178840	Capacitor
178841	Transformer
178843	Plate w/Studs, Mounting
178859	Circuit Card (See page 5-3)
178868	Resistor, Fixed
178886	Cable Assembly
178887	Cable Assembly
178888	Clip
179260	Cover

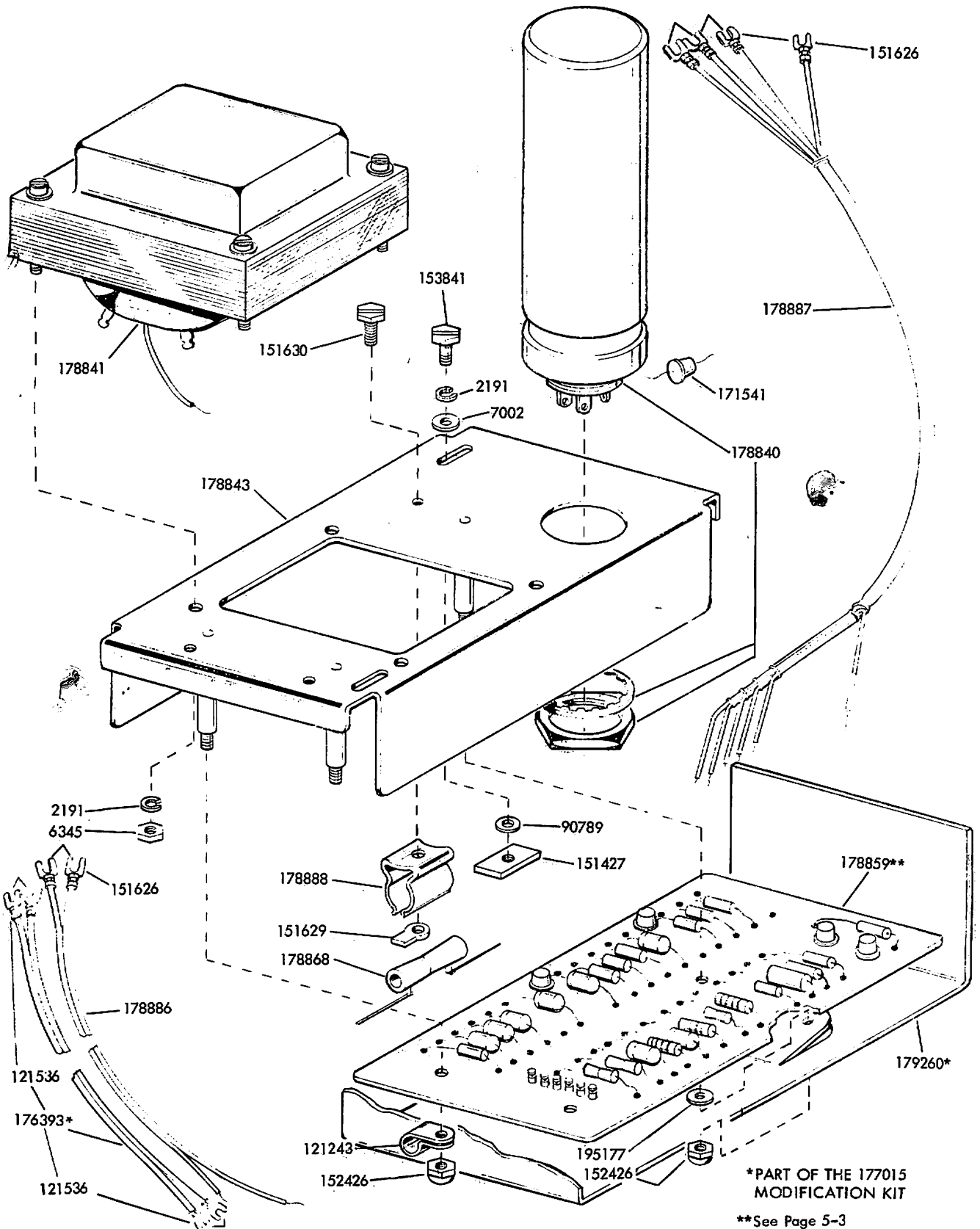
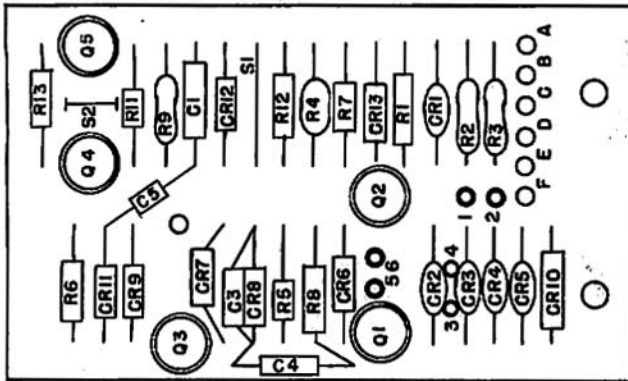

Figure 5-1. 177010 Electronic Selector Magnet Driver



178859 Circuit Card

Ref. Design	Teletype Part No.	Total Qty.	Name and Description	
C1, C5	178860	2	Capacitor	.022MFD
C3, C4	179529	2	Capacitor	1.0 MFD
CR1, CR2	178844	5	Varistor	100A
CR3, 4, 5			Same as CR1	
CR6	179463	3	Diode	
CR7			Same as CR6	
CR8	178847	1	Diode	
CR9	178848	3	Diode	
CR10			Same as CR9	
CR11	178857	1	Diode	
CR12			Same as CR9	
CR13			Same as CR6	
Q1, 2, 3, 4, 5	179665	5	Transistor	
			<u>Ohms</u>	<u>Watts</u>
R1	178862	1	10	1
R2	178865	1	124	1/2
R3	178866	1	249	1/2
R4	178867	1	2000	3
R5	137603	1	510	1/2
R6	178863	2	3300	1
R7	129852	1	2200	1/2
R8	178864	1	3900	1
R9	178883	1	1500	3
R11	137438	1	100	1/2
R12			Same as R6	
R13	118147	1	6800	1/2