

CATALOG



TELETYPE® MODEL 38 DATA TERMINALS

APRIL, 1973 EDITION

CONTENTS

	Page
Economy, Reliability and Performance	2
Low-Cost, Multi-Featured Line	3
Wide Page Copy with Up-Low and Two-Color Printing	4
Full ASCII Keyboard	6
More Economy with Tape	8
DC Current, EIA, Modem Interface	10
Full Control Capabilities	11
Answer-Back	14
Choice of Desk or Pedestal Mount	14
Dependable, Convenient Service	15
Useful Technical Facts	15
Simple Ordering Procedures	21
A Variety of Accessories	27

ECONOMY, RELIABILITY AND PERFORMANCE

Teletype Corporation's model 38 line is a continuation of the economical design concepts, proven reliability, and exceptional performance that have made our model 33 the most popular terminal on-line today.

Now, our 38 line lets you combine this economy and reliability with a number of the industry's most sought after performance features. Features such as wide page copy as used for computer print-outs, upper-lower case and two-color printing for maximum clarity of data presentation, and a variety of interface options for plug to plug compatibility with nearly any switched or private line system. Our built-in modem interface, for example, operates over voice-grade channels and provides options for manual originate and manual or automatic answer operation.

This catalog gives you the general and technical information you want to know about the 38 line. There are also easy-to-follow selection guides to help you choose the 38 terminals that meet your specific system requirements.

LOW-COST, MULTI-FEATURED LINE

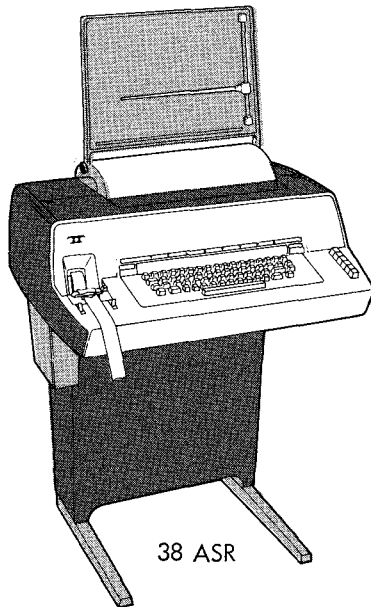

38 ASR

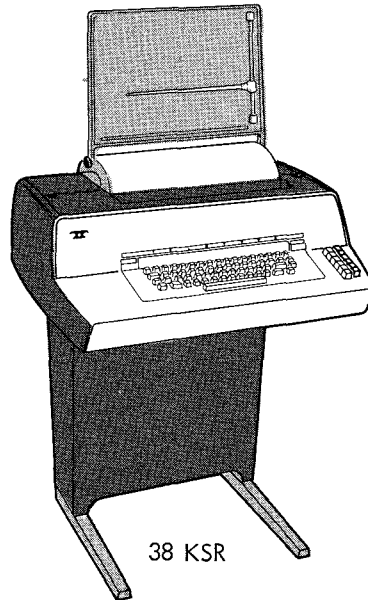

38 KSR

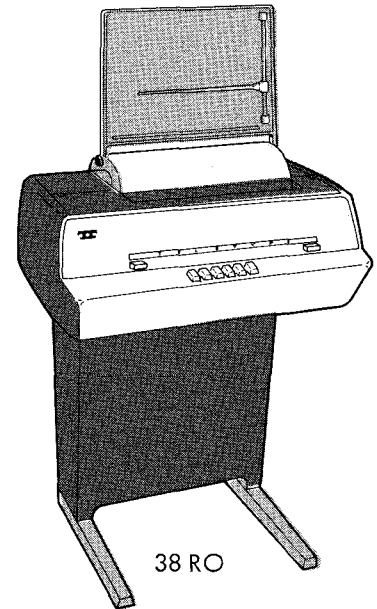

38 RO

The model 38 is a standard-duty line of low-cost terminals for entering, transmitting, receiving, and recording data in communication systems. The terminals are available in several configurations with various combinations of keyboard entry, printed page copy, and paper tape facilities.

Pin-fed, wide (14-7/8") page copy and upper-lower case and two-color printing are standard features on all 38 terminals.

The terminals operate at ten characters per second (110 baud) and feature a four-row keyboard capable of generating all of the 128 characters in the American National Standard Code for Information Interchange (ASCII).

Several different interfaces are available. One terminal arrangement provides facilities for either dc current (20 or 60 milliamperes) or voltage (EIA RS-232-C). Another provides a built-in modem with facilities for manual-originate and either manual- or automatic-answer. Another permits the customer to provide his own logic and interface circuitry.

A number of features in the 38 line may be enabled or disabled by the user to meet varying operational requirements. Instructions are furnished with the terminal.

A wide variety of accessories are available including a modification kit that allows the terminal to use either wide, fan-folded, pin-fed paper or 8-1/2-inch wide, friction-fed paper rolls.

Terminals are available for operation on either 60 Hz or 50 Hz power frequencies. 60 Hz pedestal-mount terminals are listed by Underwriters' Laboratories (UL). UL and Canadian Standards Association (CSA) listing is pending on 60 Hz table-mounted terminals. CSA listing is also pending on all 50 Hz terminals.

THREE BASIC CONFIGURATIONS

38 ASR

Automatic Send-Receive Terminal

ASR terminals offer the widest range of operational features in the 38 line. They provide keyboard data entry, printed page copy, and paper tape facilities. With the ASR terminal, you can transmit data manually by keyboard or automatically by punched tape, and simultaneously print local page copy for visual reference with or without punched tape. Or you can punch tape off-line from the keyboard or tape reader while printing local page copy. The terminal receives data as printed page copy and (if selected) punched tape. Tape transmitting and receiving can be controlled manually or automatically.

38 KSR

Keyboard Send-Receive Terminal

KSR terminals provide keyboard data entry and printed page copy facilities. You can transmit data manually on the KSR keyboard while printing local page copy. The terminal receives data as printed page copy.

38 RO Receive-Only Terminal

RO terminals receive data as printed page copy. They have a limited transmitting capability with the optional answer-back feature which enables them to transmit station identification sequences.

CHOICE OF HALF OR FULL DUPLEX

All of the 38 terminal configurations have the option of operating in the half or full duplex transmission mode. In half duplex, the terminal can either send or receive, but it cannot do both at the same time. In full duplex, it can transmit (eg, by keyboard or paper tape) and receive (eg, on page copy or punched tape) simultaneously. Full duplex operation lets you nearly double your traffic volume with only a moderate increase in line charges.

EXPANDABLE CAPABILITIES

A number of accessories, features, and configurations, other than those covered in this catalog, are available. Accessories include a wide variety of paper and tape handling devices to simplify media handling and parity error detectors to improve data accuracy.

If you have a large volume of data to transmit on-line, you can add Teletype® 4210 magnetic tape terminal and increase on-line speed to 1050, 1200, 2000, or 2400 baud.

Model 38's with Teletype 9100 station controllers can be used in private line selective calling systems which save you line charges by having a number of stations share a single communication channel. These controllers provide such functions as motor control, parity error detection and indication, and polling and address recognition and response.

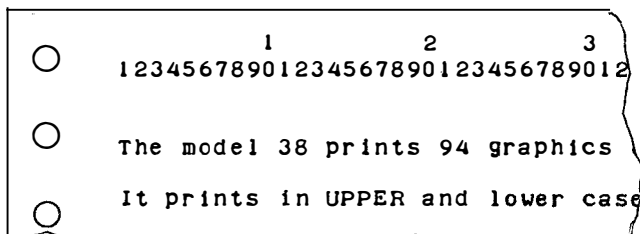

OTHER LOW COST TERMINALS

Teletype model 32 (5 level) and 33 (8 level) data terminal lines offer performance, flexibility, and economy comparable to the 38 line, but print on 8-1/2-inch paper.

Model 38 terminals are also available with APL features or with a keyboard having a numeric cluster. Or you can have versions of the 38 that use paper 8-1/2-inches wide rather than 14-7/8-inches.

Contact Teletype Corporation for additional information on the above expandable capabilities and low-cost terminals (see back cover).

WIDE PAGE COPY WITH UP-LOW AND TWO-COLOR PRINTING

IMPACT PRINTING AND PIN FEED

38 data terminals use an impact printer with a cylindrical typewheel to produce the same wide copy used in the computer room. Thus you can transmit data generated by your computer to any number of remote locations without time-wasting reformatting problems. And it is ideal for applications where all data for an entry must fit on a single line of printing.

The pin-feed platen is 15 inches wide and accepts 14-7/8-inch fan-folded computer paper stock. Also, it is capable of handling paper 375 mm wide conforming to the ISO Standard. Holes along the edge of the paper engage pins on the printer platen to feed the paper and maintain positive alignment.

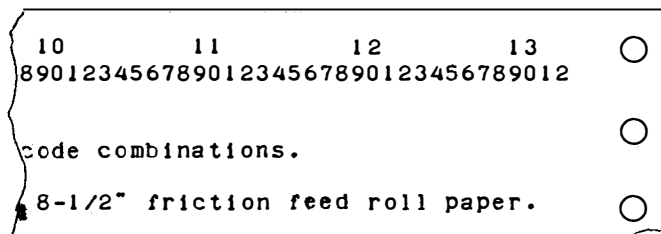

(Size reduced approximately 18%)

MULTIPLE COPIES

The terminal's impact printer will produce an original and a minimum of two carbon copies.

UPPER/LOWER CASE PRINTING

(For Text Editing)

A standard feature of 38 data terminals is printing of the upper and lower case alphabet. It is particularly useful for a number of applications such as computerized typesetting and text editing.

TWO-COLOR PRINTING

(To Differentiate Data)

Two-color printing (typically red/black) is another standard feature of all 38 data terminals. It can be used to distinguish priority information and to separate computer input and output data.

The remote or local color shift is made in response to this two-character sequence:

ESC 3 - RED Printing
 ESC 4 - BLACK Printing

CHOICE OF THREE CHARACTER SETS

Typewheels contain a maximum of 94 printing characters plus the non-printing graphics space and delete. The three combinations offered in the selection guide are shown on pages 6 and 7. The typewheel character set (the graphics printed on the page) is shown immediately above its associated keytop arrangement.

Note that the selection includes arrangements with a slash zero or a slash alpha "O", and the latest ASCII arrangement (typewheel AD and Keytop AAW) with a distinct character difference between the zero 0 and alpha O.

VERSATILE FORMAT CAPABILITY

A customer-installed modification kit is available that lets the terminal use either pin-fed, fan-folded 14-7/8-inch widepaper or 8-1/2 inch wide friction-fed paper rolls. This provides a simple way of changing the terminal's format capability to meet varying requirements.

CONVENIENT FORM FEED

For the convenience of the operator, forms can be easily and accurately advanced into printing position by simultaneously depressing the CONTRL (control) and FF (form feed) keys. A

standard form (11 inches long) or a half-size sheet (5-1/2 inches long) are accommodated. Customer-installed modification kits are available for a variety of other form sizes.

END OF LINE INDICATIONS

The approach of the end of line is signaled by the ringing of a bell. The indication occurs approximately 10 characters from the right-hand margin.

The bell also responds to the on-line control code BEL (CONTRL, G).

LOCAL CR AND LF

The local CR and LF keys are provided so your operator can return the print mechanism to the left margin and feed paper thru the terminal without using the regular keyboard as this would cause electrical signals to be transmitted and could affect a remote terminal's page copy alignment.

These controls are located immediately above the keyboard on ASR and KSR's and have the same relative location on RO terminals.

SELECTABLE AUTOMATIC CR AND LF

When this customer-selectable feature is activated, completion of the 132nd character causes the automatic return of the printing mechanism to the left-hand margin and brings a new line into printing position. This action prevents "over-typing" at the end of a line. Terminals leave the factory with this feature disabled. You can easily enable it by removing two clips from the typing unit.

Note: Positioning of the 132nd character may be displaced horizontally and vertically.

PAPER ALARM

The paper supply is constantly monitored by a low paper sensor. When the end of the paper supply is sensed, an ALARM indicator lights to alert the operator.

CHARACTER AND LINE SPACING

Terminals are factory-adjusted for a 132-character line, with 10 characters to-the-inch horizontal spacing. Single or double vertical line spacing (6 or 3 lines per inch) is selectable by the operator. To make this selection, the operator simply moves a lever on the printer.

CONTROL OF NON-PRINTING FUNCTIONS

A function box initiates a number of non-printing actions such as carriage return, line feed, space, etc. in response to specific control codes. It can be arranged to perform certain additional functions such as contact openings or closures to control peripheral equipment.

ASR terminals have function box contacts for the following control codes: DC1, DC3, ENQ and EOT. See page 20 for an explanation of their function.

FULL ASCII KEYBOARD

Keyboards on 38 terminals can generate the full complement of 128 characters in the ASCII code, including the upper and lower case alphabet and non-printing control codes. The characters are generated in even parity but can be optioned for eight level always mark or always space. In appearance and general layout, the keyboards are similar to conventional office typewriters, so training of new or inexperienced operators is easy and fast.

PRINTING AND NON-PRINTING CHARACTERS

The 38 keyboard generates both printing and non-printing characters, ie, in some cases a code is transmitted but printing does not occur. It's easy to tell one from the other. Refer to the typewheel layout above the keyboard below and on page 7. Only the characters shown will print.

Lower keytop character (Unshift Row on Layout)

Characters shown on the lower-half of the keytops are printed when the keyboard is in the unshifted mode — just depress the key. Alpha characters are printed in lower case.

Upper keytop character (Shift Rows on layout)

The graphics printed in the shift mode are obtained by holding the SHIFT key depressed while operating the associated character key, as with a standard typewriter. Alpha characters are printed in upper case.

To continuously print upper case characters, depress the SHIFT LOCK key.

Control Characters (Non-Printing)

Neither printing nor spacing occur when control characters are selected; instead, an electrical signal is generated which results in:

1. Communication Controls (eg, ACK, ENQ)
2. Format Effectors (eg, LF, FF)
3. Device Controls (eg, DC1, DC2)
4. Information Separators (eg, FS, GS)

The 38 keyboard generates all of the ASCII control characters. These are easily identified by the standard ASCII designation in black on the upper-half of the keytop. To generate a control character, you hold the CONTRL key down

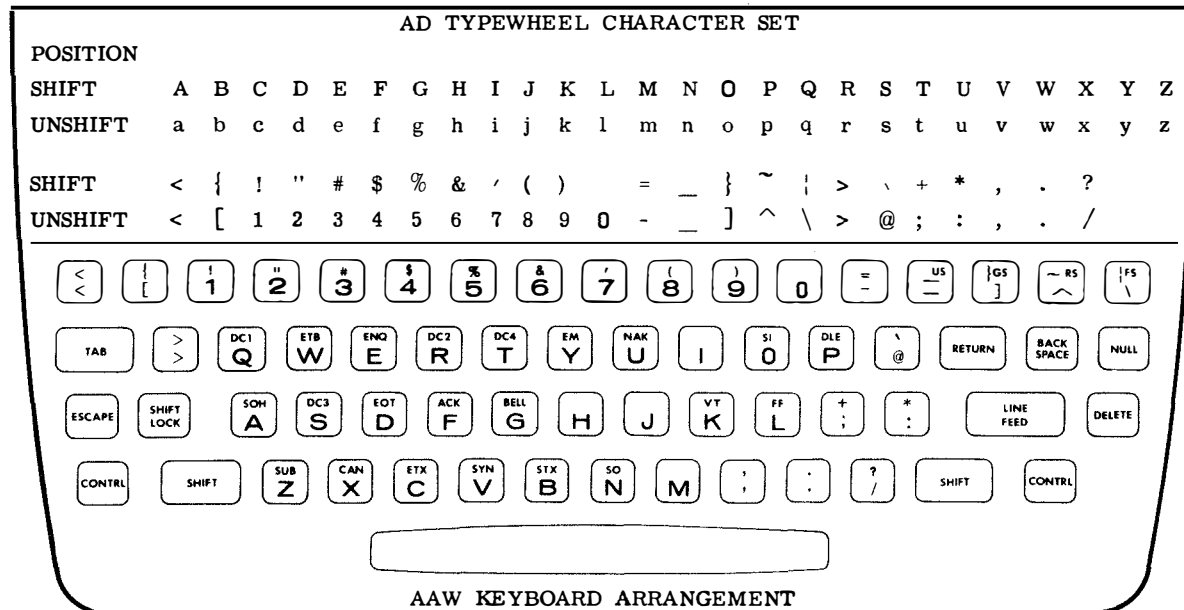

and strike the proper character key. Commonly used controls (eg, line feed, return, etc.) have their own keys placed at the periphery of the keyboard to make them easy to locate. These do not require use of the CONTRL key.

6 and 7. All of the arrangements use the latest ASCII designations for control characters. Note that there is a difference in the appearance of the zero and alpha "O" for data processing purposes:

CHOICE OF THREE ASCII ARRANGEMENTS

Terminals are available with any of the three typewheel-keytop configurations shown on pages

Typewheel	Numeric	Alpha
AD	0	O
AF	∅	O
AG	0	∅

AF TYPEWHEEL CHARACTER SET

POSITION

SHIFT	A	B	C	D	E	F	G	H	I	J	K	L	M	N	O	P	Q	R	S	T	U	V	W	X	Y	Z
UNSHIFT	a	b	c	d	e	f	g	h	i	j	k	l	m	n	o	p	q	r	s	t	u	v	w	x	y	z
SHIFT	<	{	!	"	#	\$	%	&	'	()	=	_	}	~		>	\	+	*	,	.	?			
UNSHIFT	<	[1	2	3	4	5	6	7	8	9	∅	-	_]	^	\	>	@	;	:	,	.	/		

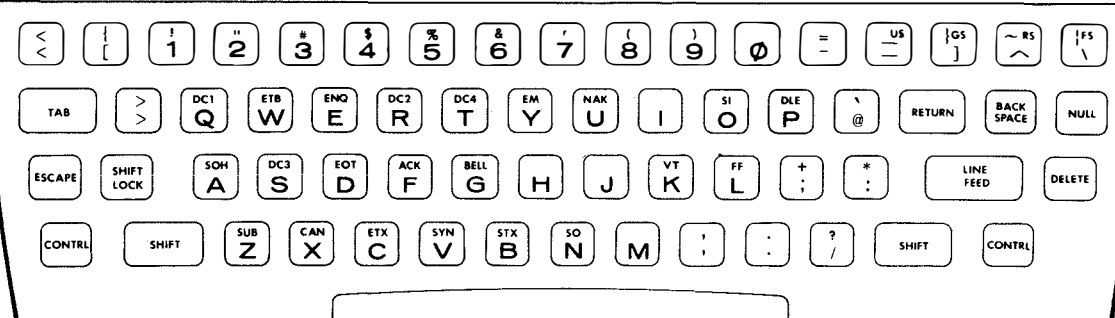

ABW KEYBOARD ARRANGEMENT

AG TYPEWHEEL CHARACTER SET

POSITION

SHIFT	A	B	C	D	E	F	G	H	I	J	K	L	M	N	∅	P	Q	R	S	T	U	V	W	X	Y	Z
UNSHIFT	a	b	c	d	e	f	g	h	i	j	k	l	m	n	o	p	q	r	s	t	u	v	w	x	y	z
SHIFT	<	{	!	"	#	\$	%	&	'	()	=	_	}	~		>	\	+	*	,	.	?			
UNSHIFT	<	[1	2	3	4	5	6	7	8	9	0	-	_]	^	\	>	@	;	:	,	.	/		

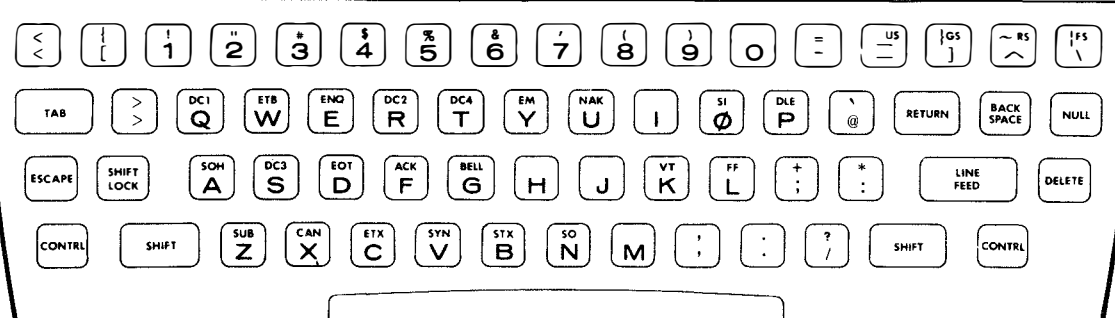

ACW KEYBOARD ARRANGEMENT

EVEN PARITY (For Error Detection)

The 38 keyboard generates code combinations with even parity, ie, there are an even number of marking bits over the sum of the 8 bits in the code. This can be used for error control if the receiver is equipped to detect parity. To meet varying system requirements, screw straps are provided on the keyboard circuit card to make the 8th bit of keyboard generated signals either always marking or always spacing.

SELECTABLE ALL CAPS OUTPUT

The 38 keyboard can be optionally programmed to generate upper case alpha characters only; the lower case characters normally generated in the unshift mode are then converted to upper case. This feature makes 38 terminals compatible with existing computer programs written in monospace for 33 and 35 terminals. Option is activated by a screw strap on the keyboard circuit card.

REPEATABLE CHARACTERS

This feature makes operations such as under-scoring and continuous spacing easier and faster by simply depressing the key below its normal stop. It is possible to individually activate (or deactivate) the repeat feature of any key by simply removing the clip associated with it. The following keys are made repeatable at the factory: Line Feed, Space, Null, Delete, Colon (:), Asterisk (*), Hyphen (-) or Equal (=), Shift and Unshift Period (.), Shift and Unshift Underscore (_), Shift and Unshift (X).

ERROR-PREVENTING INTERLOCK

A keyboard interlock prevents errors commonly caused by depressing two keys simultaneously. When one key reaches a certain point in the downstroke, all of the other keys are "locked out" until the depressed key returns to the unoperated position.

END OF LINE FORMAT

At the end of each line of copy you should insert the three character sequence RETURN, LINE FEED, DELETE. Following this format you are assured that the printing mechanism will have sufficient time to completely return to the left hand margin before the first character of the next line is printed.

MORE ECONOMY WITH TAPE

INCREASE SYSTEM SPEED AND ACCURACY

A paper tape punch and reader are integral components of 38 ASR terminals. They offer a number of time and labor saving benefits as well as adding greater flexibility and accuracy to data communication systems. You can prepare error-free data on tape, for example, and send it at maximum terminal speed, and you can send and receive automatically at hours when line charges are lower.

Both units are especially easy to operate and are located beside the keyboard for convenient access by the operator.

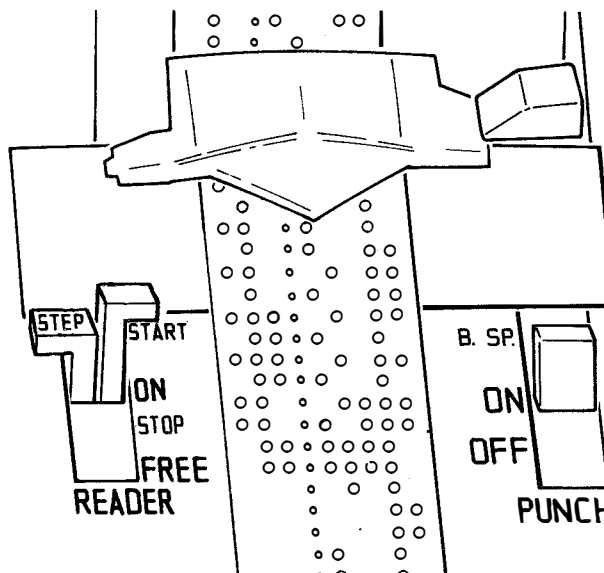

MANUAL/AUTOMATIC PUNCH

A customer-activated option provides a choice of either manual or automatic punch operation. ASR terminals are shipped with the punch in the manual mode of operation. It can be placed in the automatic mode by simply removing two clips.

The punch is operated manually by a simple control lever. In automatic operation it is controlled by specific on-line codes, but it also can be manually controlled.

Manual Operation

- ON - Turns punch on. Permits characters received by printer (local or on-line) to be punched in tape.
- OFF - Turns punch off.
- B. SP. - Primarily used for tape correction. Each time control lever is moved to this position, tape moves one character space in reverse direction.

Automatic Operation

In the automatic mode, the punch will respond to ASCII control codes as follows:

- DC2 - Turns the punch on.
- DC4 - Turns the punch off.

A remote terminal sending the DC2 code can turn the punch of the receiving terminal on without an operator being present. Data then can be received. The transmitting terminal can turn the receiving terminal's punch off at the end of the transmission by using the DC4 code.

Only the DC4 code will appear in the punched tape.

During automatic operation, the control lever moves to the ON position when the punch is turned on and back to the OFF position when it is turned OFF.

When preparing tape for subsequent transmission, all control codes with the exception of information separators should be followed by two DELETE characters. This will allow the terminal to perform the control action before additional data is transmitted.

Easy Error Correction

Correcting paper tape is easy. You use the control lever to move the tape back one character at a time. When the errored character is in position, you use the DELETE key to overpunch it and any characters that follow. When a terminal receives the delete characters, no printing or spacing will occur, and page copy will be in the proper format.

Tape Storage and Chad Collection

A tape storage container (under the terminal cover) can store a standard 8-inch diameter roll of tape.

A chad box that attaches to the side of the terminal pedestal is used to collect paper particles produced by the punch. This box, easily removed for periodic cleaning, is furnished with pedestal mounted terminals. If desk mounted terminals are selected, the customer must provide for chad collection.

See Technical Facts, page 19 for tape specifications.

MANUAL/AUTOMATIC READER

To meet varying requirements, the reader, like the punch, can be operated either manually or automatically. ASR terminals are shipped with the reader wired for manual operation. The automatic mode can be easily selected by means of a simple wiring change.

The reader is controlled manually by a simple control lever. In automatic operation it is controlled by specific on-line codes, but it also can be manually controlled.

Manual Operation

- START - Momentarily moving the control lever to this position starts reader.
- STEP - One character is read each time the control lever is moved from ON to STEP.
- ON - Control lever is spring-loaded to return to this position from START, STEP or STOP. (Control lever must be in ON position for automatic operation.)
- STOP - Momentarily moving control lever to this position stops reader.
- FREE - Tape can be positioned in the reader head when the control lever is at FREE. Lever must be manually returned to ON.

Automatic Operation

When the automatic mode has been activated and the control lever is in the ON position, the reader will respond to the receipt of ASCII control codes as follows:

- DC1 — Turns reader on.
- DC3 — Turns reader off.
- ENQ — Stops the reader and trips the remote answer-back. To automatically start reader after ENQ, the last answer-back character must be DC1.
- EOT — Turns reader off.

TIGHT TAPE AND END OF TAPE FEATURES

These features guard against tearing the tape and needless reader operation. The reader will automatically stop if the tape becomes tight or tangled or the end of tape is sensed.

DC CURRENT, EIA, MODEM INTERFACE

COMPATIBILITY WITH MOST SYSTEMS

Several different interfaces are available with 38 terminals to make them compatible with a wide range of system requirements. These are integrated into the electrical service unit (ESU) (see page 14) which houses the terminal's electrical components and logic and provides a convenient area for electrical interconnection.

There are two series of 60-Hertz 38 terminals: one series provides either dc current or EIA voltage interface as a customer activated option. The other series provides a modem interface with manual-originate and either manual- or automatic- answer, again as a customer option. There are also two series of 50-Hertz terminals: One provides the dc current-EIA voltage configuration described above. The other has no electrical service unit so that the customer can provide his own logic and interface circuitry.

DC CURRENT OR EIA VOLTAGE INTERFACE

The dc current interface provides a 20 or 60 milliampere dc neutral signal. It is often used

on local loops and for mini-computer consoles. Terminals are wired for 20 ma at the factory; 60 ma is a customer-activated option. Solid state circuitry permits operation on high or low voltage.

The voltage interface lets you connect to any device specifying the EIA standard RS-232-C, including business machines, common carrier data sets, and customer owned modems. If you choose to use this interface, you should order the separate cable described on page 17 to terminate the interface leads in a standard EIA connector.

MODEM INTERFACE

Choice of Manual or Automatic Answer

Model 38 built-in modem provides for operation on voice-grade channels in switched network and private line systems. It offers exceptional operational flexibility for computer access and conversational applications. This FSK (frequency shift keying) modem can provide manual originate/manual answer or manual originate/automatic answer when connected to the appropriate Bell System Data Access Arrangement (DAA). The modem is code insensitive, transmits asynchronously in serial form, and is compatible with Bell System 101, 103, and 113 data sets or their equivalents.

With manual originate/manual answer, the call is established manually by a telephone handset, and the operators exchange voice communication before going to data mode. They may go back to voice communication at any time during the transmission. The call is terminated manually.

With manual originate/automatic answer, the terminal can receive a call at any time whether an operator is present or not. It will automatically answer, go to data mode, send and/or receive data, and then go "on hook" to await the next call. This gives you the opportunity to use the terminal at night when line charges are lower. As with manual originate/manual answer, voice communication may be established at any time during the call if an operator is present at the called terminal.

Total Terminal Arrangement from a Single Source

Terminals with the built-in modem are performance-tested as a package by Teletype Corporation. This means you can have a com-

plete terminal arrangement — checked-out and simple to install — from a single source. The only installation adjustment that may be required is setting the signal level so that it matches the telephone line.

Data Access Arrangements (DAA)

The data access arrangements required are:

- Manual Originate/ - Bell System 1000A
Manual Answer CDT or equivalent
- Manual Originate/ - Bell System 1001B
Automatic Answer CBT or equivalent

Refer to pages 18 and 19 for modem and DAA specifications.

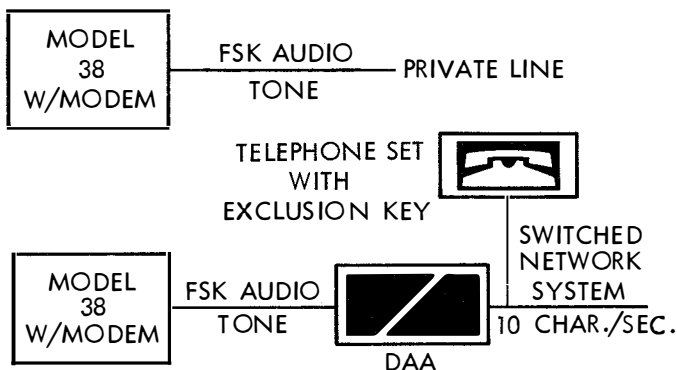

For the arrangement shown above, a Bell 502-type telephone set with exclusion key is required for network signaling and voice communication and to perform the voice-data transfer on the telephone line.

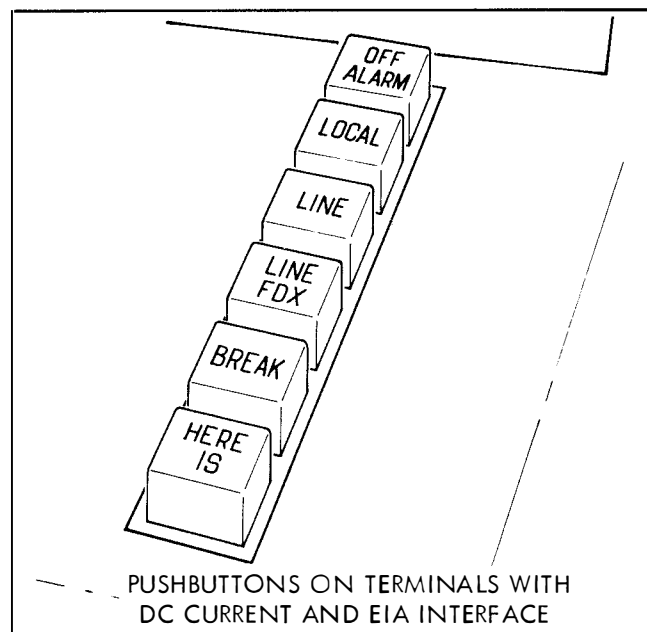

The data access arrangement required for connection of a data terminal to the telephone network and the 502-type telephone set must be ordered separately from your local telephone company.

For information on ordering the proper DAA, refer to Teletype model 33 and 38 Technical Reference, Part 2, Article 2, "Data Coupler Arrangements Used with Teletype® Cataloged Model 33 and 38 Terminals with Built-In Modem." Or you can refer to the following two Bell System Technical References for ordering information and the methods of connecting your terminals to the DAA's: "Data Access Arrangement CDT for Manual Originating and Answering Terminals," PUB 41801, May, 1971 and "Data Couplers CBS and CBT for Automatic Terminals," Aug., 1970 and the Addendum 1, March, 1971. There are a number of modem options. Refer to page 18 for a complete listing.





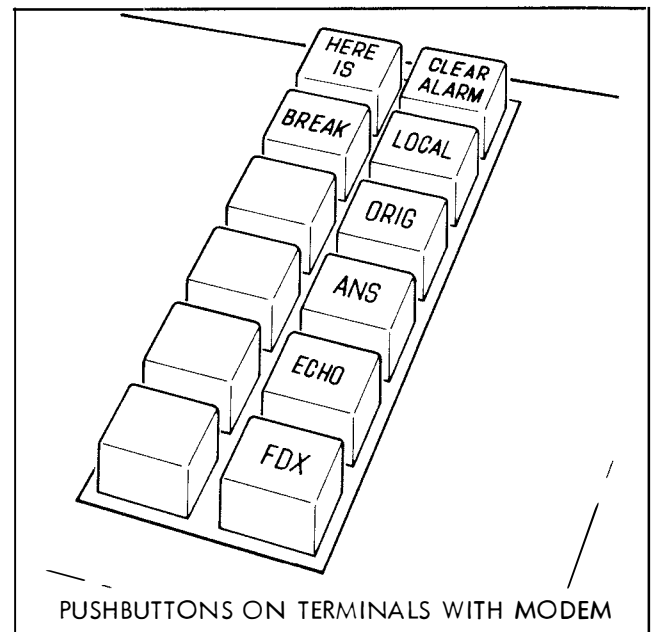

FULL CONTROL CAPABILITIES

Pushbuttons located on the right side of the keyboard give you full and easy control of the 38's versatile functions. Terminals with dc current and EIA voltage interfaces have one row of buttons. For those with modem, the ASR and KSR have two rows, and the RO has one row without BREAK and HERE IS. The controls' functions are described on pages 12 and 13.



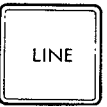







38 DATA TERMINALS

CONTROL FUNCTIONS DC — EIA INTERFACES

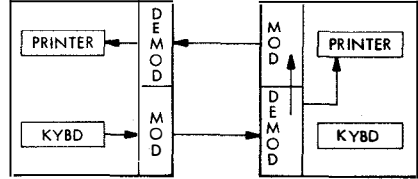
PUSH BUTTON CONTROL	DC INTERFACE		EIA INTERFACE
	Control Function with HDX Option	Control Function with FDX Option	Control Function
 OFF ALARM (Red Cap)	Turns terminal motor off. Illuminates in ALARM.		Turns terminal motor off. Motor will not respond to Data Set Ready lead at interface. Illuminates in ALARM and presents Data Terminal Ready off at interface.
 LOCAL (Green Cap)	Turns terminal motor on. Terminal has complete local capability but can not send or receive on the signal line.		Turns terminal motor on. Terminal has complete local capability but can not send or receive on the signal line. Motor does not respond to Data Set Ready. Presents Data Terminal Ready off at interface.
 LINE (Clear Cap)	Turns terminal motor on. Terminal has complete capability to send or receive in HDX mode with local copy.		Turns motor on in response to Data Set Ready on at interface. If no ALARM conditions exist, it presents Data Terminal Ready on at interface. Terminal has complete capability to send and receive in HDX mode with local copy.
 LINE FDX (Clear Cap)	Turns terminal motor on. Terminal has complete capability to send or receive in HDX mode with local copy. Label (LINE FDX) may be removed from push button for HDX operation.	Turns terminal motor on. Terminal has complete capability to send and receive simultaneously in FDX mode without local copy.	Turns terminal motor on in response to Data Set Ready on at interface. If no ALARM conditions exist, it presents Data Terminal Ready on at interface. Terminal has complete capability to send and receive in FDX mode without local copy.
 BREAK (Clear Cap)	When BREAK push button is depressed, a spacing condition is placed on the signal line in the LINE and LINE FDX modes.		
 HERE IS (Clear Cap)	Momentary depression of HERE IS push button causes the terminal's answer-back to transmit a programmed message. This control operates in the LOCAL, LINE, and LINE FDX modes. <u>Note:</u> Terminal's motor must be on.		

CONTROL FUNCTIONS MODEM INTERFACE

PUSH BUTTON CONTROL	Manual Originate/Manual Answer DAA 1000A CDT	Manual Originate/Automatic Answer DAA 1001B CBT
 (Red Cap)	<p>CLEAR turns terminal motor and transmit carrier off. Telephone must be disconnected manually by the operator. Terminal responds to the manual answer routine in the normal manner.</p> <p>Illuminates in ALARM. Telephone is functional, terminal will respond to ANS. push button when depressed.</p>	<p>CLEAR turns terminal motor and transmit carrier off. Terminal will automatically disconnect. Terminal responds to the automatic answer routine in the normal manner.</p> <p>Illuminates in ALARM. Terminal will automatically answer an incoming call.</p>
 (Green Cap)	<p>Turns terminal motor on. Terminal has complete local capability, but can not send or receive on signal line.</p>	<p>Terminal will not automatically answer an incoming call. An incoming call is indicated by ringing of the telephone set and by flashing of the ANS. push button.</p>
 (Clear Cap)	<p>Turns terminal motor on and allows transmit mark frequency (F1m) to turn on after receipt of receive mark frequency (F2m). When lighted, indicates presence of receive carrier. Motor and carrier will turn off if carrier is not received within 25 seconds.</p>	
 (Clear Cap)	<p>Depressing the ANS. push button turns the terminal motor and F2m carrier on. Illuminates when receive carrier is present. Motor and carrier will turn off if carrier is not received within 25 seconds. Answer-back will operate automatically (if terminal is so equipped and this feature is enabled).</p> <p>Note: Telephone must be disconnected by the operator.</p>	<p>The ANS. push button flashes in response to ringing when telephone is on hook. The call is automatically answered when terminal is in the data mode. This turns the terminal motor and F2m carrier on. ANS. push button illuminates when receive carrier is present. Answer-back will automatically operate (if terminal is so equipped and this feature is enabled). The call will automatically disconnect if carrier is not received within 25 seconds.</p>
 (Clear Cap)	<p>Conditions terminal for error-checking or on-line testing. Originating terminal goes to FDX mode. Called terminal goes to ANS. and ECHO modes. Transmitted data is "echoed" back from answering terminal to originating terminal's printer. Correct data on originating terminal's printer gives substantial assurance that the message was received correctly.</p>	
 (Clear Cap)	<p>When depressed and lighted, this push button electrically separates the send and receive circuits for full duplex operation. When not depressed and unlighted, the terminal is in the half duplex mode.</p>	
 (Clear Cap)	<p>Momentary depression of HERE IS push button causes the terminal's answer-back to transmit a programmed message.</p> <p>Note: Terminal's motor must be on.</p>	
 (Clear Cap)	<p>When BREAK push button is depressed, a spacing condition is placed on the signal line.</p>	

ANSWER-BACK

TRANSMITS STATION IDENTIFICATION

Answer-back is a simple device that permits a called station to automatically identify itself by transmitting a programmed sequence of characters. This saves time and prevents costly transmission charges due to misdirected data.

EASY CODING

You can easily encode the answer-back message on a plastic drum which has a capacity of 20 characters. You can choose either one-, two- or three-cycle operation with 20, 9 or 6 characters per cycle, respectively. If multiple-cycle operation is chosen, the identical message is normally used in each cycle.

NON-CONTENTION

The answer-back feature is turned on when the terminal receives ENQ. To prevent two answer-back devices from operating simultaneously, the device at the transmitting terminal is not activated when the ENQ code is sent from its keyboard or reader. You can operate the answer-back locally by pressing the HERE-IS key.

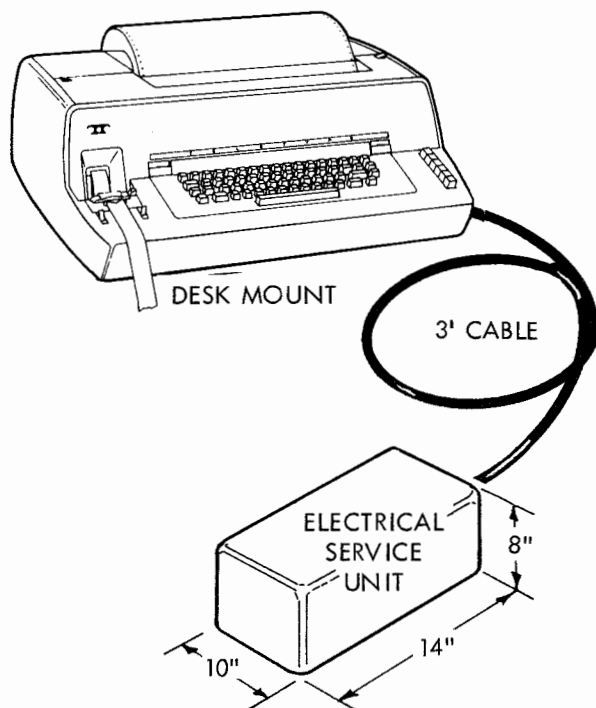

SELECTABLE OPERATION ON CALL CONNECTION

Terminals equipped with answer-back and modem have the option of automatically tripping the answer-back on call connection. This feature may be enabled or disabled by the user. Terminals are factory-wired with this feature enabled.

CHOICE OF DESK OR PEDESTAL MOUNT

You can choose from either a pedestal mount, which provides a neat, free-standing installation, or a desk mount for use where floor space is at a premium. Both blend perfectly into every modern office decor.

The pedestal mount provides mounting provisions for the electrical service unit and includes storage facilities for auxiliary equipment.

The desk mount requires additional space for installation of the electrical service unit; desk mount ASR terminals also require provision for chad collection.

Refer to page 20 for cabinet colors, weights, and dimensions, and to page 27 for a listing of useful accessories.

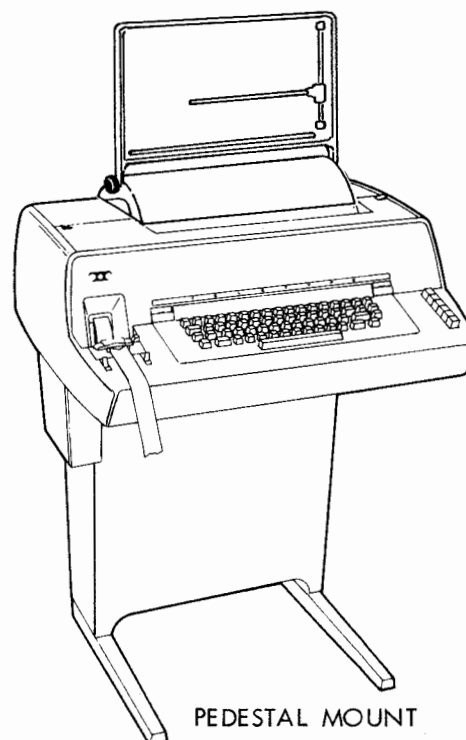

DEPENDABLE CONVENIENT SERVICE

Teletype Corporation's products are fully supported by our Product Service Organization. For your convenience, centers are located in various areas across the country. Services include on-site maintenance and repair on a contractual or "on-call" basis, initial installation

and check-out, installation of factory approved modification kits, exchange repair, and overhaul. Special services are also available on request. Contact Teletype Corporation for additional information (see back cover).

USEFUL TECHNICAL FACTS

CODE

1968 ASCII (X3.4-1968, American National Standard Code for Information Interchange)

X3.4-1968

Bits					COLUMN									
b7	b6	b5	b4	b3	b2	b1	0	0	0	0	1	1	1	1
					0	0	1	1	0	0	1	1	0	1
					0	1	2	3	4	5	6	7		
ROW					0	1	2	3	4	5	6	7		
0	0	0	0	0	NUL	DLE	SP	0	@	P	'	p		
0	0	0	1	1	SOH	DC1	!	1	A	Q	a	q		
0	0	1	0	2	STX	DC2	"	2	B	R	b	r		
0	0	1	1	3	ETX	DC3	#	3	C	S	c	s		
0	1	0	0	4	EOT	DC4	\$	4	D	T	d	t		
0	1	0	1	5	ENQ	NAK	%	5	E	U	e	u		
0	1	1	0	6	ACK	SYN	&	6	F	V	f	v		
0	1	1	1	7	BEL	ETB	'	7	G	W	g	w		
1	0	0	0	8	BS	CAN	(8	H	X	h	x		
1	0	0	1	9	HT	EM)	9	I	Y	i	y		
1	0	1	0	10	LF	SUB	*	:	J	Z	j	z		
1	0	1	1	11	VT	ESC	+	;	K	[k	{		
1	1	0	0	12	FF	FS	,	<	L	\	l			
1	1	0	1	13	CR	GS	-	=	M]	m	}		
1	1	1	0	14	SO	RS	.	>	N	^	n	~		
1	1	1	1	15	SI	US	/	?	O	—	o	DEL		

All characters in these two rows + SP (space) and DEL (delete) are non-printing

Parity (Keyboard Generated Characters)

Terminals are factory-wired for even parity over the eight bits, but they may be strapped by the customer so that the eighth bit is always marking (state 1) or always spacing (state 0).

Code Structure

8-Level 11 Unit Code Structure
(dc neutral signal is illustrated)

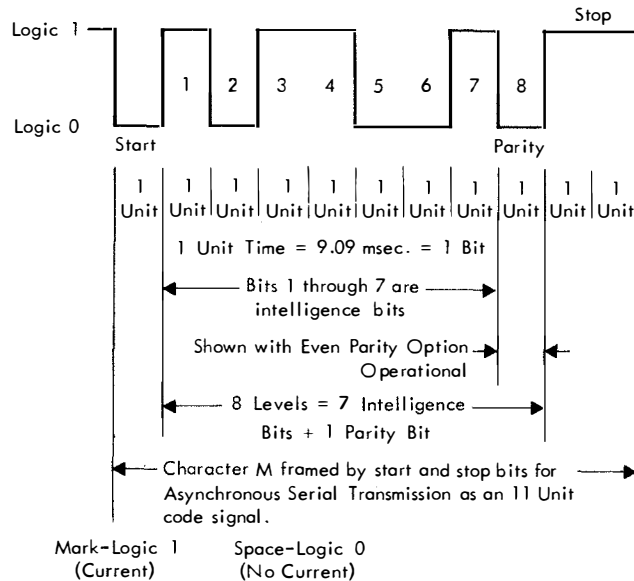

Transmitting and Receiving Margins

The following design criteria are met by model 38 terminals:

Receiving — Terminals can accept a signal with a maximum of 35% bias distortion, 33% end distortion.

Transmitting — Signals from terminals will have no more than 5% distortion.

SPEED

10 characters/sec, 11 unit code, 110 baud

100 words/min (word consists of 6 characters)

600 operations/minute

INTERFACE

Options (60 Hz Terminals)

NOTE: 50 Hertz Terminals offer choice of DC current and EIA or terminal with no ESU (See pages 24, 25 and 26)

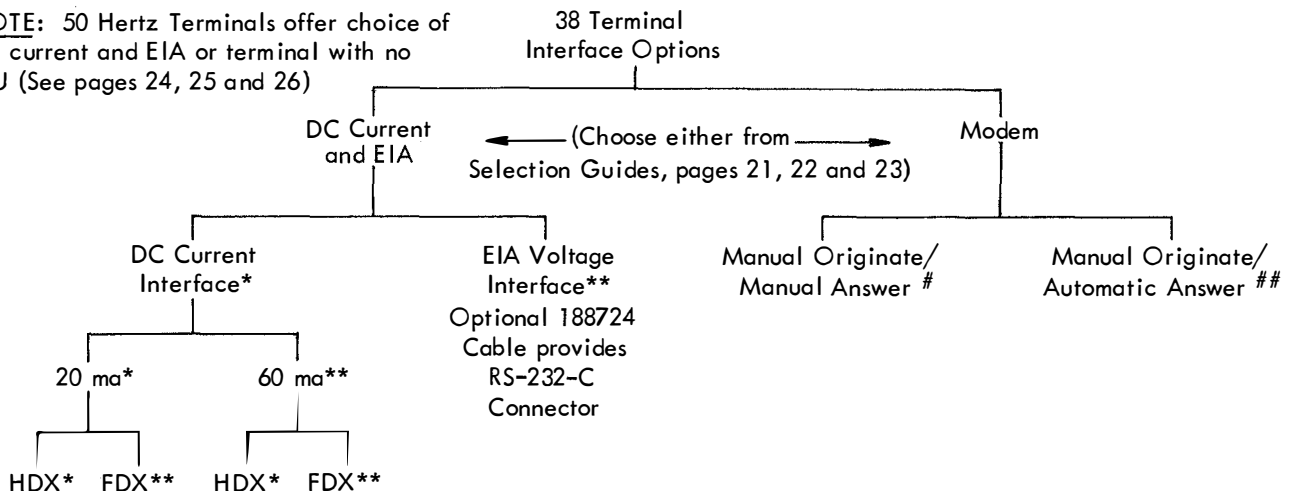

* = Factory Wired ** = Wiring Option

Order Data Access Arrangement 1000A, USOC Code CDT, and 502 telephone set from local telephone company.
Order Data Access Arrangement 1001B, USOC Code CBT, and 502 telephone set from local telephone company.

Current and EIA Interfaces

Terminal control and signal interface are provided by connector P11 on ESU circuit card.

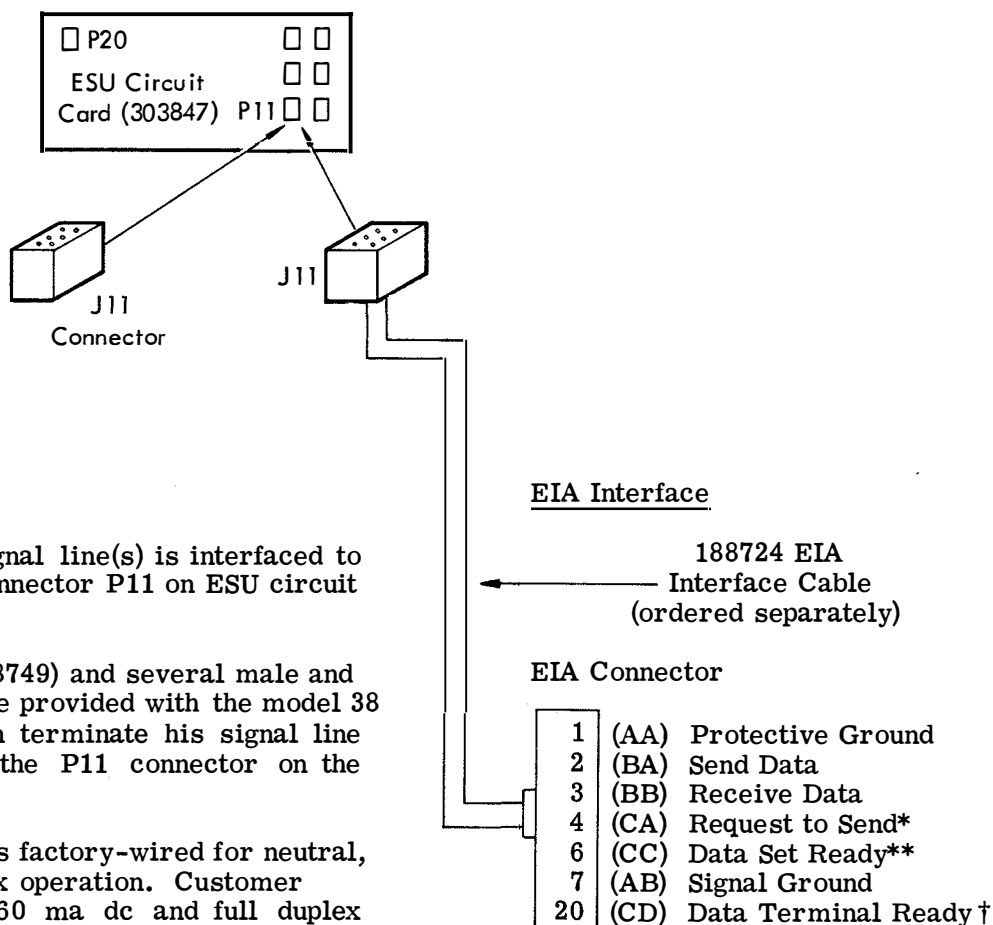

Current Interface

Connection of dc signal line(s) is interfaced to the terminal thru connector P11 on ESU circuit card.

A J11 connector (188749) and several male and female terminals are provided with the model 38 so the customer can terminate his signal line interface cable at the P11 connector on the circuit board.

Signal line current is factory-wired for neutral, 20 ma dc, half duplex operation. Customer wired options for 60 ma dc and full duplex operation are available on the terminal (see page 16). Solid state circuitry permits operation on high or low voltage (3 to 125 VDC).

The following interface leads are available at connector P20 on the ESU circuit board.

1. Paper alarm contacts
2. Answer-back trip coil leads. Customer must provide a contact closure for operation.
3. ASR terminal's EOT contact.

Refer to WDP 0320 for circuit connections and wiring options.

EIA Interface

188724 EIA
 Interface Cable
 (ordered separately)

EIA Connector

1	(AA)	Protective Ground
2	(BA)	Send Data
3	(BB)	Receive Data
4	(CA)	Request to Send*
6	(CC)	Data Set Ready**
7	(AB)	Signal Ground
20	(CD)	Data Terminal Ready†

EIA Send and Receive:
 (+) = Space, (-) = Mark

*Output held high whenever power is applied to terminal.

**EIA input (+) turns motor on, (-) turns motor off (motor control relay).

†Output held on if all of the following conditions are met.

EOT switch not sensing EOT.
 LOCAL button not depressed.
 OFF button not depressed.
 Paper-alarm switch not sensing paper out condition.

Modem Options

The following modem options are available. The factory wired options for the specified data access arrangements are indicated by an asterisk (*).

	DAA 1000A CDT Manual Answer	DAA 1001B CBT Automatic Answer
1. PAPER ALARM		
*Only ALARM button lights.	X	X
Same condition as above, except subsequent data connections are prevented until alarm is cleared.	X	X
2. ANSWER-BACK TRIP		
Occurs automatically at called terminal on call connection. (Terminal must have answer-back feature and modem.)		
*Enabled	X	X
Disabled	X	X
3. ECHO MODE		
Output of distributor and break key in ECHO mode.		
*Blinded	X	X
Unblinded	X	X

See page 27 for modification kit providing dc current interface with modem.

The terminal provides a 7 conductor cable for interfacing to the data access arrangement. The following leads from the cable connect to the respective DAA's:

Interface Cable Lead	Manual Originate/Manual Answer (DAA 1000A CDT or Equivalent)	Manual Originate/Automatic Answer (DAA 1001B CBT or Equivalent)
Red	DR (Data Ring)	DR (Data Ring)
Orange	DT (Data Tip)	DT (Data Tip)
Yellow		RI (Ring Indicator)
Black		DA (Data Transmission)
Green		OH (Off Hook)
White		+V (Positive DC Power)
Blue		-V (Power Return)

Modem Specifications

- Mode — Half Duplex (HDX)
 — Full Duplex (FDX)
- Transmission Method — Serial by bit
- Frequencies (Hz):
- | | | Receive | Transmit |
|----------------|-------|---------|----------|
| Originate Mode | Mark | 2225 | 1270 |
| | Space | 2025 | 1070 |
| Answer Mode | Mark | 1270 | 2225 |
| | Space | 1070 | 2025 |
- NOTE: F1m = 1270 F2m = 2225
 F1s = 1070 F2s = 2025
- Timing — Asynchronous
- Signal Level — 0 to -12 dBm transmit (adjustable to match transmission network)
 — 0 to -50 dBm receive (under control of carrier detect circuitry)
- Echo Suppressor Disable — Receipt of answering terminal's carrier disables echo suppressors on transmission facilities.
- Compatible with — Bell System 101, 103, 108 and 113 data set or equivalent.
- Carrier Detect Indication — The ORIG or ANS button will light when depressed if received carrier is present.

SPROCKET (PIN) FEED FORMS

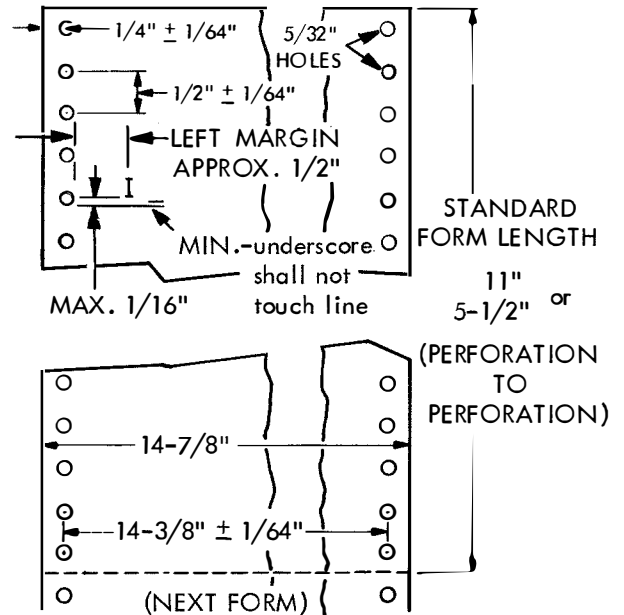

ROLLED PAPER

(Used with 188800 8-1/2" Paper Modification)

Standard teleprinter roll paper has the following specifications:

Outside Diameter	5 inch maximum
Width of page	8.453 ± .031 inches
Length per roll (approx)	400 feet
Core Diameter I.D.	1 inch + .1 - .05 inch

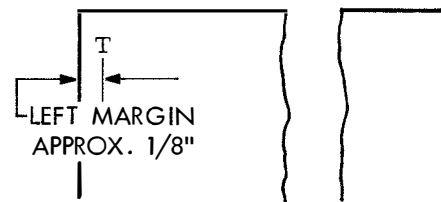

RIBBON

Ink impregnated Nylon, two-color (black/red)

PAPER TAPE SPECIFICATIONS

- Type of paper — oiled stock, rolled
- Width — 1 inch
- Thickness — 0.004 inch
- Max. diameter of roll — 8 inches
- Length per roll (approx.) — 1000 feet
- Core diameter of roll — 2 inches

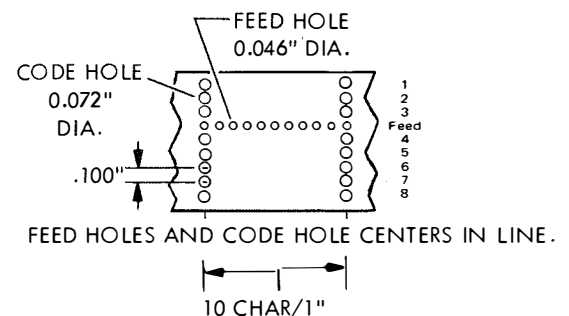

38 DATA TERMINALS

ELECTRICAL REQUIREMENTS

Input Voltages:

115 VAC $\pm 10\%$ 60 Hz $\pm 3/4\%$ single phase
 115 VAC $\pm 10\%$ 50 Hz $\pm 3/4\%$ single phase

Nominal Power Requirements:

60 Hz Motor	50 Hz Motor
Running current	Running current
1.9 amperes.	1.9 amperes.
128 watts	130 watts

Starting Surge - 15 amperes maximum
 Maximum Running Current - 5 amperes

A convenience outlet is available on the electrical service unit which permits up to 100 watts of additional load.

MAINTENANCE

Initial Lubrication - After 100 to 200 hours operation
 Maintenance Interval - Every 750 hours or 6 mos., whichever occurs first.

An optional elapsed timer is available for recording the "terminal on" time (see Accessories).

These publications are shipped with respective terminals:

DC/EIA Wiring Diagrams - WDP 0320
 Modem Wiring Diagrams - WDP 0344

Installation and Servicing Manual

ASR, KSR, RO - No. 341

Operator's Manual

ASR, KSR, RO - No. 342

The following maintenance manuals are available from Teletype Corporation:

Description, Lubrication
 Disassembly, Reassembly, Troubleshooting
 ASR - No. 343, Vol. 1
 KSR, RO - No. 344, Vol. 1

Adjustments

ASR - No. 343, Vol. 2
 KSR, RO - No. 344, Vol. 2

Parts

ASR - No. 343, Vol. 3
 KSR, RO - No. 344, Vol. 3

ENVIRONMENTAL REQUIREMENTS

Operating: 40° to 110°F ambient measured outside of terminal cover.

Storage: -40° to 150°F.

Relative Humidity: 90% maximum at 100°F maximum.

COLOR

Charcoal grey cover with ivory colored keyboard
 Pedestal is charcoal grey with satin chrome feet

WEIGHTS AND DIMENSIONS

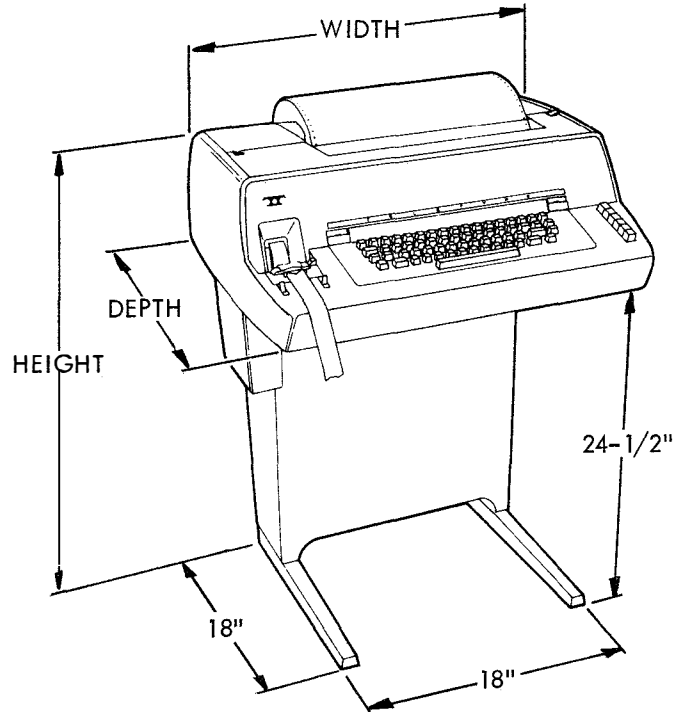

Overall Dimensions

Terminal	Height	Width	Depth	Approx. Weight
ASR	36 in.	25 in.	21 in.	98 lbs.
KSR	36 in.	25 in.	21 in.	90 lbs.
RO	36 in.	25 in.	18-1/2 in.	85 lbs.

FUNCTION BOX CONTACTS

Contacts

Purpose

DC1, DC3,
 ENQ, EOT

Automatic Control of Reader

EOT

DC Interface-Provides contact closure at interface for customer application

EIA Interface-Controls Data Terminal Ready lead and turns set off.

Modem Interface-Provides for call disconnect.

SIMPLE ORDERING PROCEDURES

The terminals designated by catalog number on the following pages offer a wide range of operational flexibility. If you have requirements that these configurations do not satisfy, contact Teletype Corporation (see back cover).

The ordering information is divided into two parts according to power frequency (60 or 50 Hz). Each part contains three charts, one for each terminal configuration (ASR, KSR, RO). The charts show various arrangements of standard

and optional features and provide a catalog number for each arrangement.

60 Hz	
38 ASR	Page 21
38 KSR	Page 22
38 RO	Page 23
50 Hz	
38 ASR	Page 24
38 KSR	Page 25
38 RO	Page 26

MODEL 38 ASR DATA TERMINALS — 60 Hz

STANDARD FEATURES	Type of Paper Feed	Typewheel-Keypoint Arrangements			Furniture Arrangements		Catalog Numbers	
		1968 ASCII AD Typewheel AAW Keypoint	∅ Zero AF Typewheel ABW Keypoint	∅ Alpha AG Typewheel ACW Keypoint	Pedestal Copyholder Chad Box	Desk Mount (Rubber Feet)	20/60 Mo. D.C. Neu. Sig. Line or E.I.A. Interface (RS-232-C)	Modem w/ Manual Orig. and Manual or Automatic Answer
ASCII Code 10 char/sec (100 WPM)	W I D E P L A T E D	•			•		3850/6JA	3850/6JG
11 Unit Code		•				•	3850/6JB	3850/6JH
Upper and Lower Case Printing			•			•	3850/6JC	3850/6JJ
Red/block Printing †				•			3850/6JD	3850/6JK
Even Parity Keyboard*					•	•	3850/6JE	3850/6JL
Auto**/Man Reader					•	•	3850/6JF	3850/6JM
Single Step Reader Control								
Auto ‡ /Man Punch								
Auto CR/LF on 132nd Char. #								
Paper Alarm								
Answer Bock								

† Controlled by Two Character Sequence.

* Customer Activated Option to Disable Keyboard Even Parity and have 8th Level of Keyboard Generated Characters always Mark or always Space.

** Customer Activated Option for Automatic Reader Control on DC1 and DC3.

‡ Customer Activated Option for Automatic Perforator Control on DC2 and DC4 Code.

Customer Activated Option.

NOTE: 60 Hz pedestal-mount terminals are UL listed (E49631).

38 DATA TERMINALS

MODEL 38 KSR DATA TERMINALS — 60 Hz

STANDARD FEATURES	Type of Paper Feed	Typewheel-Keytop Arrangements			Furniture Arrangements		Catalog Numbers	
		1968 ASCII AD Typewheel AAW Keytop	ø Zero AF Typewheel ABW Keytop	ø Alpha AG Typewheel ACW Keytop	Pedestal Copyholder	Desk Mount (Rubber Feet)	20/60 Ma. D.C. Neu. Sig. Line or E.I.A. Interface (RS-232-C)	Modem w/ Manual Orig. and Manual or Automatic Answer
ASCII Code 10 char/sec (100 WPM) 11 Unit Code Upper and Lower Case Printing Red/black Printing † Even Parity Keyboard* Auto CR/LF on 132nd Char.** Paper Alarm Answer Back	W I D E N	•			•		3840/4EA	3840/4EG
		•				•	3840/4EB	3840/4EH
		•			•		3840/4EC	3840/4EJ
		•				•	3840/4ED	3840/4EK
				•	•		3840/4EE	3840/4EL
				•		•	3840/4EF	3840/4EM

†Controlled by Two Character Sequence.

*Customer Activated Option to Disable Keyboard Even Parity and have 8th Level of Keyboard Generated Characters always Mark or always Space.

**Customer Activated Option.

NOTE: 60 Hz pedestal-mount terminals are UL listed (E49631).

MODEL 38 RO DATA TERMINALS — 60 Hz

STANDARD FEATURES	Type of Paper Feed	Answer Back Feature	Typewheel Arrangements			Furniture Arrangements		Catalog Numbers	
			1968 ASCII AD Typewheel	∅ Zero AF Typewheel	∅ Alpha AG Typewheel	Pedestal Copyholder	Desk Mount (Rubber Feet)	20/60 Ma. D.C. Neu. Sig. Line or E.I.A. Interface (RS-232-C)	Modem w/ Manual Orig. and Manual or Automatic Answer
ASCII Code	W I D E P L A T E D	Without Ans. Back	•			•		3830/2AA	3830/2AG
10 char/sec (100 WPM)			•				•	3830/2AB	3830/2AH
11 Unit Code				•			•	3830/2AC	3830/2AJ
Upper and Lower Case Printing				•		•	•	3830/2AD	3830/2AK
						•		3830/2AE	3830/2AL
						•	•	3830/2AF	3830/2AM
Red/black Printing †		20 Char. Ans. Back	•			•		3830/4AA	3830/4AG
			•				•	3830/4AB	3830/4AH
Auto CR/LF on 132nd Char.*				•			•	3830/4AC	3830/4AJ
				•			•	3830/4AD	3830/4AK
Paper Alarm						•	•	3830/4AE	3830/4AL
						•	•	3830/4AF	3830/4AM

†Controlled by Two Character Sequence.

*Customer Activated Option.

NOTE: 60 Hz pedestal-mount terminals are UL listed (E49631).

38 DATA TERMINALS

MODEL 38 ASR DATA TERMINALS — 50 Hz

STANDARD FEATURES	Type of Paper Feed	Typewheel-Keytop Arrangements			Furniture Arrangements		Catalog Numbers	
		1968 ASCII AD Typewheel AAW Keytop	ø Zero AF Typewheel ABW Keytop	ø Alpha AG Typewheel ACW Keytop	Pedestal Copyholder Chad Box	Desk Mount (Rubber Feet)	20/60 Ma. D.C. Neu. Sig. Line or E.I.A. Interface (RS-232-C)	Without Electrical Service Unit
ASCII Code 10 char/sec (100 WPM)	W I D E P L A T E D	•			•		3850/6WA	3850/6WN
11 Unit Code Upper and Lower Case Printing		•				•	3850/6WB	3850/6WP
Red/black Printing†			•		•		3850/6WC	3850/6WQ
Even Parity Keyboard*			•			•	3850/6WD	3850/6WR
Auto**/Man Reader Single Step Reader Control				•		•	3850/6WE	3850/6WS
Auto‡/Man Punch Auto CR/LF on 132nd Char. # Paper Alarm				•		•	3850/6WF	3850/6WT
Answer Back								

†Controlled by Two Character Sequence.

*Customer Activated Option to Disable Keyboard Even Parity and have 8th Level of Keyboard Generated Characters always Mark or always Space.

**Customer Activated Option for Automatic Reader Control on DC1 and DC3.

‡Customer Activated Option for Automatic Perforator Control on DC2 and DC4 Code.

#Customer Activated Option.

MODEL 38 KSR DATA TERMINALS — 50 Hz

STANDARD FEATURES	Type of Paper Feed	Typewheel-Keypoint Arrangements			Furniture Arrangements		Catalog Numbers	
		1968 ASCII AD Typewheel AAW Keypoint	∅ Zero AF Typewheel ABW Keypoint	∅ Alpha AG Typewheel ACW Keypoint	Pedestal Copyholder	Desk Mount (Rubber Feet)	20/60 Ma. D.C. Neu. Sig. Line or E.I.A. Interface (RS-232-C)	Without Electrical Service Unit
ASCII Code 10 char/sec (100 WPM) 11 Unit Code Upper and Lower Case Printing Red/black Printing † Even Parity Keyboard* Auto CR/LF on 132nd Char.** Paper Alarm Answer Back	W I D E N P L E A T E D	•			•		3840/4SA	3840/4SN
		•				•	3840/4SB	3840/4SP
			•		•	3840/4SC	3840/4SQ	
			•		•	3840/4SD	3840/4SR	
				•	•	3840/4SE	3840/4SS	
				•	•	3840/4SF	3840/4ST	

†Controlled by Two Character Sequence.

*Customer Activated Option to Disable Keyboard Even Parity and have 8th Level of Keyboard Generated Characters always Mark or always Space.

**Customer Activated Option.

38 DATA TERMINALS

MODEL 38 RO DATA TERMINALS — 50 Hz

STANDARD FEATURES	Type of Paper Feed	Answer Back Feature	Typewheel Arrangements			Furniture Arrangements		Catalog Numbers	
			1968 ASCII AD Typewheel	ø Zero AF Typewheel	ø Alpha AG Typewheel	Pedestal Copyholder	Desk Mount (Rubber Feet)	20/60 Ma. D.C. Neu. Sig. Line or E.I.A. Interface (RS-232-C)	Without Electrical Service Unit
ASCII Code	W I D E P L A T E D	Without Ans. Back	•			•		3830/2NA	3830/2NN
10 char/sec (100 WPM)			•				•	3830/2NB	3830/2NP
11 Unit Code				•			•	3830/2NC	3830/2NQ
Upper and Lower Case Printing				•			•	3830/2ND	3830/2NR
Red/black Printing †						•	•	3830/2NE	3830/2NS
						•	•	3830/2NF	3830/2NT
Auto CR/LF on 132nd Char.*		20 Char. Ans. Back	•			•		3830/4NA	3830/4NN
			•				•	3830/4NB	3830/4NP
Paper Alarm				•			•	3830/4NC	3830/4NQ
				•			•	3830/4ND	3830/4NR
						•	•	3830/4NE	3830/4NS
						•	•	3830/4NF	3830/4NT
						•	•		

†Controlled by Two Character Sequence.

*Customer Activated Option.

VARIETY OF ACCESSORIES

PAPER AND TAPE HANDLERS

188496 Form Supply Box

Provides convenient storage in its base for a carton of 15 inch wide fan-fold forms. Top is a shelf used to temporarily store forms after processing. Adds 13-1/2 inches to depth of terminal.

188500 Copy Holder

Holds information at a convenient viewing position for the operator.

188388 Low Tape Alarm

Monitors the terminal's tape supply and turns on the ALARM lamp when a low tape condition occurs.

TELETYPE Paper and Tape Handling Catalog

Lists other accessories which may be useful in your particular system.

FURNITURE

343693GF Telephone Shelf

For model 38 equipped with modem. This shelf attaches to the pedestal for convenient support of the 502-type telephone set.

188642 Pedestal

Complete base assembly to convert from desk mount (customer provided furniture) to manufacturer's designed base.

WT001 Table

A larger "desk type" mounting facility which affords more space for customer provided electronics.

312879 Right Hand Door (for WT001) must be ordered separately.

343897 Form Accumulator Modification Kit (for WT001)

Provides convenient means of temporarily storing forms after processing. Attaches to WT001. Must be ordered separately.

PAGE COPY

188800 Friction Feed 8-1/2 inch Wide Paper Modification

May be installed in the 38 to accommodate 8-1/2 inch wide rolled paper. When rolled paper is

removed the terminal is immediately available for wide, 14-7/8 inch, paper applications. Uses existing paper alarm mechanism.

188944 Modification Kit for "ON-LINE" Backspace

Terminals equipped with this modification will backspace one character position each time the ASCII code BS (Backspace) is received.

Feature is especially useful for text editing, underscoring, or overstriking of characters.

326184 Two-Color Ribbon

Nylon base, red/black inked.

PAPER TAPE

188953 Chad Box

Collects the chad produced by punching paper tape.

MAINTENANCE

SOP 188660 Elapsed Time Meter (60 Hz)

SOP 188419 Elapsed Time Meter (50 Hz)

A "running time" meter which measures in hours the accumulated time the terminal is turned on.

INTERFACE

188724 EIA Interface Cable (Length 6 Feet)

Cabling is required to terminate interface leads in the EIA RS-232-C interface connector. One end mates with the P11 connector on the 303847 circuit card and the other end terminates in a standard EIA connector.

187156 Modification Kit For Current Interface with Modem

A 187156 modification kit adds flexibility to modem equipped terminals by permitting them to operate in both switched-network and dc current oriented systems. Solid-state circuitry operates on high or low voltage at 20 or 60 ma, half or full duplex.

For further information on any Teletype Corporation product lines, or for the location of your nearest sales or product service representative, please contact:

Sales headquarters—
5555 W. Touhy Ave.
Skokie, Illinois 60076

Product Service headquarters—
9930 Derby Lane
Westchester, Illinois 60153

or call TERMINAL CENTRAL—(312) 982-2500



TELETYPE CORPORATION

the computercations people

GENERAL OFFICES: 5555 Touhy Avenue, Skokie, Illinois 60076 Telephone: (312) 982-2000—TWX: 910-223-3611
and TELEX: 25-4051 (both have 24 hour automatic answering service)