

INSTRUCTION MANUAL
Electronic

IDLE LINE MOTOR CONTROL UNIT
Model 202-1

Issue No. 1 - Dated 9/1/64

PULSE COMMUNICATIONS, INC.
100 South Early Street
Alexandria, Virginia 22304
703-548-4626

MODEL 202-1 IDLE LINE MOTOR CONTROL

GENERAL

The Model 202-1 is one of PULSECOM's series of units designed to control the 115 VAC supply to a teleprinter motor (or other device). A timed interval is started at any time the signal input to the teleprinter becomes either idle or spacing (open). If no transmission is received prior to the end of this interval, the Motor Control Unit removes the ac supply from the outlet connected to the teleprinter motor. Any mark-to-space transition received thereafter will cause the Unit to restore the ac power to the teleprinter almost instantly. It should be noted that if the Motor Control Unit has timed out, the initial one or two characters received may be garbled because the teleprinter motor requires approximately 100 milliseconds before it comes up to full speed after power is reconnected.

The timed idle line or open interval before power cutoff occurs is fixed at the factory. The number of minutes is stenciled on the outside of the case. This fixed interval may be changed by substitution of resistors as described in the Installation section of this manual.

In addition to its CONTROLLED outlet to which the teleprinter power cord is connected, the Motor Control Unit also provides an UNCONTROLLED convenience outlet for connection of other devices not requiring control.

Earlier PULSECOM units, the Model 201 series, provided variable timing from 0 to 60 minutes, using an electromechanical timer. It was found that this feature was not generally required. The Model 202-1 has been provided because of its solid-state design, lower cost, and ability to accept polar loop currents as low as seven milliamperes. Where loop currents are known to exceed 25 milliamperes and variable timing is required, the Model 201-2 is available on special order.

FEATURES

Two outlets are provided, one controlled by the timing circuit and one not controlled.

Completely solid state construction, except for control relay.

Six-foot two-conductor cord provided for connection in series with telegraph loop. Cord terminates in spade terminals for screw connection. The ribbed side of cord is to be connected to the positive or "ring" side of the loop. Its terminal is marked with a red band.

Completely resistive input introduces no distortion.

Will accept neutral input currents from 30 to 100 milliamperes and polar currents from 7 to 50 milliamperes.

SPECIFICATIONS

Input Impedance	100 ohms non-reactive
Input Signals Accepted	Neutral, 30-100 ma; Polar 7-50 ma (Strap removed for polar operation), any standard tele- graph or data speed up to 200 baud.
Power Cutoff Timing	Fixed at 1, 3, 5, 10, 15, or 20 minutes <u>+ 15%</u> as ordered (15 minutes if not specified). Timing may be changed in field by resistor substitution.
Current-Carrying Capacity at CONTROLLED Outlet	20 amperes maximum, 115VAC
Restart Time	15 milliseconds to apply power to CONTROLLED outlet after receipt of a mark-to-space signal transition.
Power Required	115 V.A.C. (<u>+ 10%</u> , 50-60 cps), 5 watts.
Mounting	Three mounting holes provided in rear panel, for installation on side of teleprinter, wall, floor, or other surface.
Size	2 1/2 x 3 5/8 x 6 5/8
Weight	3 pounds

THEORY OF OPERATION (Refer to Schematic Drawing 202-1SD-406).

Power is supplied to the timing circuits from a full-wave rectifier negative supply and a half-wave positive supply. Transformer T1 provides isolation from the power line and fuse F1 protects the transformer from overloads. (When fuse F1 is removed and power is lost to the timing circuits, the teleprinter motor will operate continuously.)

The timing circuit consists of a unijunction oscillator for the time base, three stages of binary counters, an amplifier to drive the power relay, and another two-stage amplifier to increase the voltage developed across the 100 ohm telegraph loop resistor R36.

INPUT CIRCUIT

For 60 ma operation a strap must be connected between terminals 4 and 5. The 60 ma marking loop connected to the input with the polarity shown will cause the top of resistor

R36 to be -6 volts as referenced to circuit ground. This negative voltage will overcome the positive voltage supplied thru the strap (4, 5) at the base of Q10, causing Q10 to conduct. When Q10 conducts it causes Q9 to go non-conducting. When the input 60 ma. loop drops below approximately 20 ma., the positive voltage via the strap overcomes the negative voltage, causing Q10 to go non-conducting and Q9 to go conducting very quickly.

Capacitor C14 was discharged while Q9 was non-conducting and when Q9 goes conducting a momentary ground is applied to the anodes of CR5, CR9, and CR13. This ground is applied long enough to reset the counters.

Polar operation is similar to neutral operation except that the strap between terminals 4 and 5 must be broken. The negative, then positive, voltages developed across resistor R36 cause transistor Q10 to go conducting, then non-conducting.

A filter network (R35, R37, C17) is provided on the input to absorb holes and noise in the signal of 2 milliseconds or less.

Relay Amplifier

When the three counters are reset, the junction of R25 and R26 is grounded through diodes CR6, CR11, and CR12. This ground cuts off Q8, de-energizing K1 which closes the contacts and applies ac power to the teleprinter motor.

Unijunction Oscillator

The ground on the junction of R25 and R26 also provides a charge path for C3 through resistors R1 and R2. When C3 charges to a certain potential, the emitter of unijunction Q1 fires and a pulse is sent to the first stage of the counters. After seven pulses from the oscillator, transistors Q3, Q5 and Q7 of the binary counters are non-conducting. This removes the ground from the junction of R25 and R26, stops the oscillator and makes Q8 conduct which in turn operates relay K1 and stops the teleprinter motor.

Any mark-to-space transition which occurs before the seventh count will reset the counters back to zero although the oscillator runs continuously.

INSTALLATION

The Model 202-1 may be mounted in any position, either loose, or attached to the wall, floor, side of a teleprinter, or other suitable surface. Mounting bolts and self-tapping metal screws are provided with each Motor Control Unit to facilitate installation using the three holes thru its rear panel. The holes on the left are on 2 1/4 inch centers to permit 19 inch relay rack installation.

1. With ac power not connected to Motor Control Unit, remove four binding head screws, two on each side of Unit, and lift-off the cover.
2. The Model 202-1 is shipped with a strap installed between terminals 4 and 5 of printed circuit BD. No. 2. This strap must be removed if Motor Control Unit is to be used for polar operation, and reinstalled if Unit is changed later to a neutral circuit. Care should be used to apply minimum heat in soldering to terminals.
3. The Motor Control Unit is to be mounted in a convenient location, on or near the teleprinter or other device to be controlled, where there is convenient access from the Motor Control Unit to the data circuit input, 115 V.A.C. outlet, and to the teleprinter power cord. If the mounting location is not readily accessible, it may be desirable to proceed with installation connections and operational tests on the Unit before fastening it to its final mounting location.
4. It will be necessary to open the input circuit to the teleprinter and to make tests to check-out the installation. It is recommended, therefore, that the loop be removed from service and connected to a dummy circuit at the central office until the installation is complete.
5. Referring to the sketch below insert the two-conductor cord spade terminals in series with the dc loop. The red-banded terminal of the cord is positive, and the other terminal is negative. Any convenient connecting place may be used, such as a loop switchboard or teleprinter where screw terminals are available.

6. Plug the teleprinter power cord into the Model 202-1 outlet designated as CONTROLLED. A 6/32 screw is provided above the two outlets for mounting a cable clamp if desired. (The Phillips head screw should not be used for this purpose.)
7. The Model 202-1 uses a three-conductor power cord which is to be connected to 115 V.A.C. and provides three-conductor power outlets. If its power cord is plugged into a grounded outlet, and the teleprinter cord has a three-conductor plug, the teleprinter chassis and motor, and Motor Control Unit, will all be grounded. However, if a "cheater" plug is used, it is recommended that ground be connected separately.

Making Operational Checks

CAUTION: When Motor Control Unit power cord is connected, 115 V.A.C. is exposed within Unit, beware of touching any terminals other than those specified.

8. With input loop idle, apply a temporary strap across terminals 1 and 3 of BD. No. 1, shorting out resistors R1 and R2.
9. Transmit a few characters from the teleprinter keyboard (or otherwise open and close the circuit a few times) to reset the Motor Control Unit's timing circuit. Note that approximately one minute later the relay operates causing the teleprinter motor to stop. If Unit fails to time-out, refer to MAINTENANCE section for further tests.
10. Introduce a single character or momentary mark-to-space transition which should then release the relay and restore power to the CONTROLLED outlet. If unit fails to reset, refer to MAINTENANCE section for further tests.
11. Remove strap from terminals 1 and 3 of BD. No. 1.
12. The tests performed in Steps 8 thru 10 with the special strap were arranged to speed-up the check of the Motor Control Unit's timing circuit. If the installer prefers, he may repeat Step 9 timing the full period from the last transition until the Unit times out, which time interval should correspond to that stenciled on the cover within $\pm 15\%$. However, the speeded-up tests should be an adequate check of the Unit.
13. Unless necessary to make further tests, or to change time-interval timing as described below, unplug power cord of Unit and replace its cover. If not yet completed, finish mounting and final installation of Unit. Return loop to service and check loop current.

Changing Time Interval from Factory-Setting

14. In some applications it may be necessary to change the idle/open time interval before power cut-off. Contact the manufacturer for the value for R1 corresponding to time interval desired, and use a half-watt resistor to replace the one installed between terminals 2 and 3 of BD. No. 1. Arrange to check timing on a full-period basis as described above and connect a decade resistance box or miscellaneous resistance values up to 500 thousand ohms between terminals 1 and 2 of BD. No. 1. Allow Unit to time-out and then momentarily open loop to reset timing circuit. Using watch, time the period

until machine goes off. Increase decade resistance to increase timing, reduce resistance to reduce timing. When desired timing is achieved install half-watt resistor of determined value between terminals 1 and 2 of BD. No. 1.

15. After completing re-timing of Unit, redesignate timing on cover.
16. Re-timing services are available from the manufacturer at a nominal service charge.

MAINTENANCE

As a solid-state device, other than its control relay, the Model 202-1 is designed for minimum maintenance. If an oscilloscope or vacuum-tube voltmeter is available, many simple checks may be made as described below. If components are changed in the field, caution is urged against overheating printed circuit boards.

If Motor Control Unit Fails To Time-out and Cut Off Power:

1. Examine relay K1 contacts for evidence of sticking or welding.
2. If relay looks OK, check for positive and negative 25 V.D.C. at indicated points on BD. No. 2. If it appears power supply is not functioning, check fuse F1. If power supply is in trouble, but fuse is OK, check diodes CR1, CR2, and CR3. If fuse is bad and replacement fuse blows, check capacitors C1 and C2. With no strap between terminals 1 and 3.
3. If power supply is OK, check test point A which should go to ground approximately every two minutes. Note: -20 Volts is the alternate test point condition. If test point A does not go to ground check transistors Q2, Q3 and unijunction Q1.
4. If test point A is OK, check for momentary ground at test point B approximately every four minutes. If test point B does not go to ground, check transistors Q4 and Q5.
5. If test point B is OK, check for momentary ground at test point C approximately every eight minutes. If test point C does not go to ground check transistors Q6 and Q7.
6. If test point C is OK, check voltage on test point E, which should be about -20 volts D.C. when test points A, B, and C are also at about -20 volts. (all associated transistors non-conducting). If test point E voltage is correct check transistor Q8 which should be at ground (conducting).
7. If transistor Q8 is OK, examine relay coil.

If Motor Control Unit Fails To Reset:

8. With input loop idle, marking, and strap 4 and 5 in or out as determined by neutral or polar operation respectively, check for ground on test point D.
If test point D is above ground, check transistors Q9 and Q10.
9. With input loop spacing, test point D should measure approximately -22 volts. If test point D measures some other voltage, check transistors Q9 and Q10.
10. If test point D is OK, check diodes CR5, CR9, and CR13.
11. Factory service and parts are available on an expedited basis and at nominal cost.

REVISIONS				
NO/SYD	DESCRIPTION	DATE	BY	CHK APPD
A	REV PER IR-202-1SD-406-A	9/8/64	W. J.

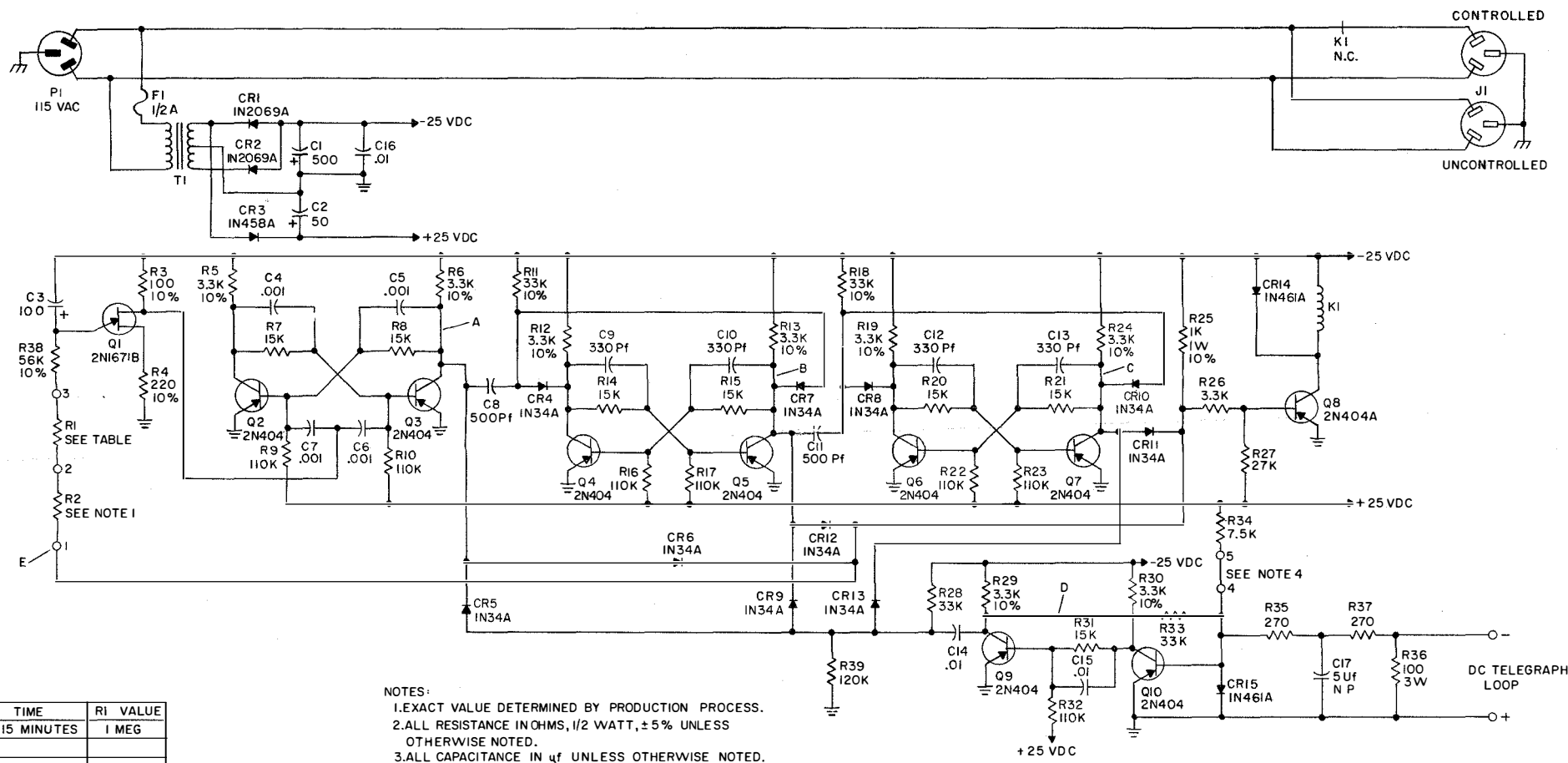

TIME	RI VALUE
15 MINUTES	1 MEG

- NOTES:
1. EXACT VALUE DETERMINED BY PRODUCTION PROCESS.
 2. ALL RESISTANCE IN OHMS, 1/2 WATT, ±5% UNLESS OTHERWISE NOTED.
 3. ALL CAPACITANCE IN μ F UNLESS OTHERWISE NOTED.
 4. REMOVE THIS STRAP FOR POLAR OPERATION.
 5. POINTS MARKED A, B, C, D & E ARE TEST POINTS.
 6. ALL DIODES EXCEPT CR1, CR2, CR3, CR6, CR11 & CR12 MAY BE SUBSTITUTED WITH PULSECOM PART NO. EP-203. CR3 MAY BE SUBSTITUTED WITH PULSECOM PART NO. EP-202.

QTY REQD	MANUFACTURER OR SUPPLIER	PART OR IDENT NUMBER	ITEM	NOMENCLATURE OR DESCRIPTION	NOTES & REF DESIGNATIONS
-1					
UNLESS OTHERWISE SPECIFIED DIMENSIONS ARE IN INCHES					
DRAWN: <i>W. J. ...</i>		DATE: 8/3/64		PULSECOM PULSE COMMUNICATIONS, INC. ALEXANDRIA, VA.	
CHECKED: <i>...</i>		DATE: 8/2/64		SCHEMATIC (IDLE LINE MOTOR CONTROL)	
DATE: <i>...</i>		DATE: 8/3/64			
DATE: <i>...</i>		DATE: 8/3/64			
MATERIAL: _____					
FINISH: _____					
CODE IDENT NO. D				DRAWING NUMBER 202-1SD-406	
SCALE: _____				SHEET _____	