

INSTRUCTIONS FOR INSTALLATION OF  
A CP43.030.100 KSR/RO MOBILE PEDESTAL

1. GENERAL

1.01 The CP43.030.100 pedestal is the same as the 430311 pedestal except for mobility, which is provided by casters on the leg assemblies of the CP43.030.100 pedestal.

1.02 The two front casters on the CP43.030.100 pedestal have a braking device, which locks in the up position.

1.03 Cord storage capability is provided by two hook-type brackets on the rear panel of the CP43.030.100 pedestal.

1.04 This specification provides the necessary information to mount a 42 or 43 KSR/RO to the CP43.030.100 mobile pedestal.

1.05 Each CP43.030.100 pedestal provides the necessary hardware to mount the 42 or 43 KSR/RO.

*Note:* When ordering replaceable components, unless otherwise specified, prefix each part number with the letters "TP" (ie, TP410055).

2. TOOLS REQUIRED

2.01 The only tool that may be required is either a 125754 nut driver 1/4 inch or a 152837 wrench 1/4 by 3/16 inch to remove the pedestal back panel.

3. INSTALLATION

3.01 Fasten the KSR/RO to the pedestal using the four clips (2-metal and 2-plastic) provided. Place KSR on top of pedestal, lining up grooves on bottom of housing with slots in pedestal and tray. Push in each clip until fully seated.

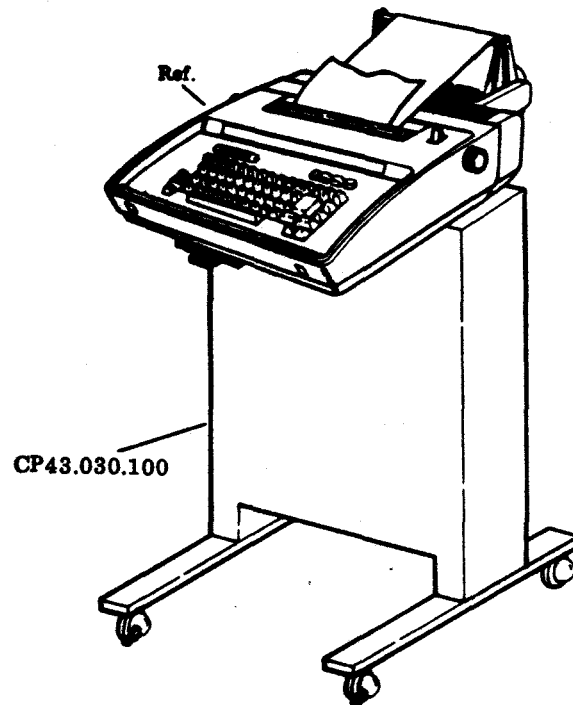
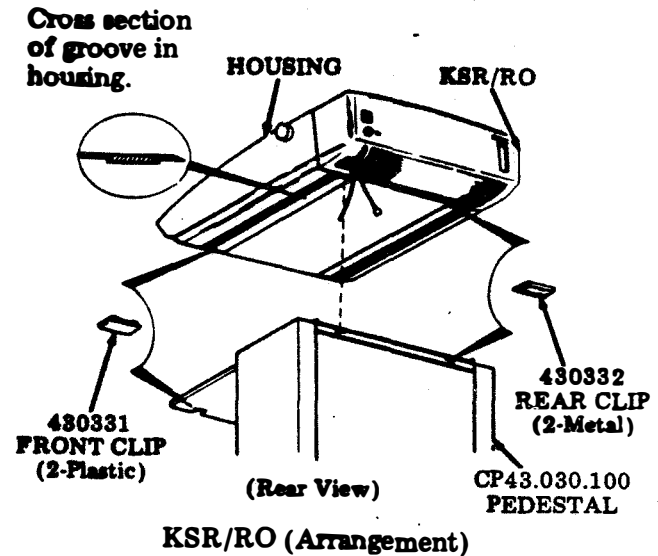

4. PARTS

4.01 Refer to illustration below for parts identification and numbering information.

