

INSTRUCTIONS FOR INSTALLING AND ADJUSTING  
THE 152332 RELAY MOTOR CONTROL ASSEMBLY  
ON ELECTRICAL SERVICE UNIT LESU7  
(BELL SYSTEM 28B)

1. GENERAL

NOTE: The 152332 Relay Motor Control Assembly cannot be used to control a D.C. motor unless adequate spark protection for the switch contacts is provided. Such a protection circuit (1 ohm in series with 0.5 mf) is a part of the 152624 capacitor resistor assembly covered in Specification 5662S.

\*a. The 152332 Relay Motor Control Assembly consists of an aluminum plate approximately 2-3/4" x 4-13/16" to which are attached a solenoid, a single-pole double-throw enclosed switch, and a five screw connection terminal block. The solenoid is mounted above the plate and the switch is mounted under a slot in the plate. The terminal block is mounted in an inverted position on the under side of the plate. A cable with four spade type terminals provides for circuitry connections to the regular motor control and power terminal blocks already present in an LESU7 Electrical Service Unit. The assembly mounts in the extreme right hand position of the Electrical Service Unit, as viewed from the front of a printer set.

b. The 152332 Relay Motor Control Assembly automatically starts and stops a printer set motor in response to predetermined signal conditions which originate at a point and which are applied to the set either over an auxiliary signal line or over the regular telegraph circuit. Methods of operation are as follows:

(1) The stopping of the motor in the printer set is accomplished by opening the power circuits thereto, under the following conditions:

(a) When wired in series with a separate motor control loop:

- (1) On supplying battery to the motor control loop.
- (2) On removing battery from the motor control loop.

(b) When a small accessory assembly is included, and the modified mechanism is wired in series with the regular telegraph signal loop:

(1) On reversal of the signal line current. (Either direction predetermined.)

(2) Motor starting shall be accomplished by reversing the stopping procedure.

c. A 152331 rectifier assembly (not provided with the 152332 assembly) is available for use when the motor control is to be energized by the polarity of battery applied to the telegraph signal line. This rectifier mounts to two adjacent terminals on the terminal block, and may be reversed in position so as to handle either polarity of line current.

## 2. THEORY OF OPERATION

### a. Operation from Separate Motor Control Loop. (Figure 1)

(1) The motor control loop is connected to Terminals C32 and C12 (cabinet terminal block) in the associated cabinet. These terminals connect to Terminals D1 and D9, respectively, in the Electrical Service Unit. The coil of the solenoid is connected directly to the latter terminals, through the assembly cable conductors. Power is supplied from an external source, and control means are located at some distant point for opening and closing the loop in order to stop and start the motor. Application of loop current, nominally .050 amperes, energizes the solenoid, causing the contacts to change position. A 93073 Resistor Modification Kit ordered separately may be mounted on the plate and connected in the coil circuit if required for limiting control line current.

(2) The relay contacts are placed in the motor circuit at Terminals E2 and E3 of the Electrical Service Unit (power terminal block). With a jumper connected to Terminals 4 and 5 of the Motor Control Assembly terminal block, the motor starts when the relay is energized and stops when the solenoid is de-energized. With the jumper connected to Terminals 3 and 4, the motor stops when the relay is energized, and starts when the relay is de-energized (inverse operation).

### b. Operation upon reversal of telegraph signal line current (Figure 2).

(1) The relay coil is inserted in the Telegraph Circuit at Terminals D4 and D8 (motor control terminal block in LESU7). The 152331 Rectifier Assembly is bridged across the relay coil in a direction to pass current when telegraph signals are being received. The 1N91 Rectifier has such low resistance in the forward direction that negligible current flows through the relay coil with the result that minimum distortion is imparted to the signals.

(2) The relay contacts connect to Terminals E2 and E3, and the motor control jumper is connected between Terminals 3 and 4 of its terminal block. Thus, with the relay de-energized, the motor circuit is closed and the motor runs continuously during the reception of telegraph signals of the proper polarity.

(3) Reversal of polarity of the telegraph loop battery (.060 ampere loop) causes the relay to be operated, since the 1N91 rectifier has such high reverse resistance that practically all the current flows through the relay coil. The relay contacts open the motor power circuit, stopping the motor. Insertion of the relay coil resistance into the signal loop causes the loop current to decrease to about .050 ampere, but since no signaling is attempted under these conditions, no harm results.

(a) When used in conjunction with Model 28 Keyboards coded LK1, LK3 and LK4, the signaling polarities noted in Figure 2 should be strictly followed. This is because the signal generator filter in these keyboards contains an r.f. noise suppressing rectifier that is effective only when the proper polarity of line current is supplied while the keyboard is generating signals. (The reversal of current when stopping the motor will not harm this rectifier.)

(b) When used in conjunction with Model 28 Keyboard LK5, or any Model 28 Receiving-Only Base Unit (LB), either the polarities shown or their opposites, may be used. When the opposite polarity, from that shown on Figure 2, is to start the motor, the 152331 rectifier assembly is inverted in position between Terminals 1 and 2 of the assembly terminal block.

(c) It should be noted that opening of the signal line, such as by a circuit failure, will cause the relay to be de-energized, thus starting the motor. This will attract the attention of the attendant so that prompt action may be taken to correct the condition.

### 3. INSTALLATION (Figure 5-13)

a. Remove the 151441 plate furthest to the right on the Electrical Service Unit. Discard the plate. Install the 152332 Assembly in the position vacated by the plate so that the relay coil will be toward the front of the Electrical Service Unit.

b. If the 152332 control is to be operated by reversal of signal line current in combination with the 152331 Rectifier, install the 152331 Rectifier between Terminals 1 and 2 from the contact side of the terminal strip.

NOTE: The arrow printed on the rectifier must point toward Terminal 2.

c. If the motor control is to mount a 93073 Resistor Modification Kit for loop current limiting purposes, mount the resistor to the hole provided in the motor control plate.

#### d. Wiring

\*(1) For operation on a separate motor control line (See Figure 1). (Normally open contacts energizing motor).

(a) Remove straps between Terminals E2 and E3 in the Electrical Service Unit.

(b) Attach the motor control leads to the Electrical Service Unit terminal blocks; Black to E2, Red to E3, and Orange to D9, White to D1.

(c) Attach the separate control line to Terminals C32 and C12.

\*(d) If inverse operation is desired, move the end of the black strap between terminals 4 and 5 of the relay motor control assembly terminal block from Terminal 5 and Terminal 3. (Normally closed contacts energizing motor).

(2) For operation in series with the signal line for operation on reversal of signal line current (See Figure 2).

(a) Remove the straps between Electrical Service Unit Terminals E2 and E3 and between D8 and D4.

(b) Attach the motor control leads to the Electrical Service Unit Terminal blocks; Black to E2, Red to E3, Orange to D8, White to D4.

(c) For normal signaling polarities other than positive at C11 and negative at B2, reverse the position of the 152331 Rectifier.

(3) If the Motor Control mounts a 93073 Resistor modification kit for loop current limiting purposes, wire in the assembly as follows:

(a) Detach the white loop tied to the magnet wires by cutting the individual tie points, but not the lacing.

(b) Route the white wire to the padding resistor and cut the wire so that the ends can reach the upper terminals without difficulty.

(c) Solder the ends of the white wire to the proper resistor lugs so as to provide resistance as desired.

\*4. ADJUSTMENTS (Figure 136)

Remake the adjustment shown in Figure 136.

\* \* \*

ALTERNATE JUMPER POSITION  
FOR INVERSE OPERATION

WHEN REQUIRED, 93073  
LOOP CURRENT LIMITING  
RESISTOR IS INSERTED  
IN THIS LEAD

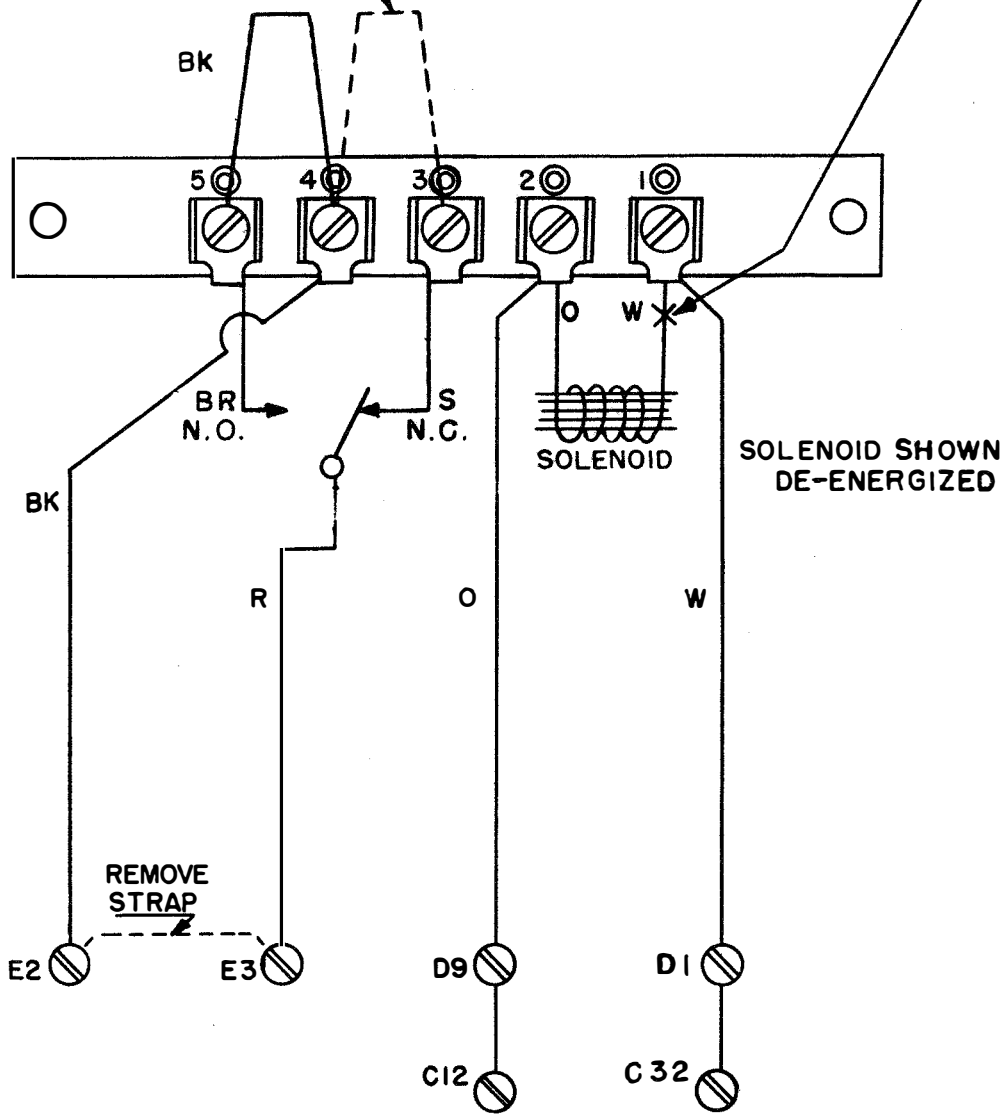

FIGURE 1

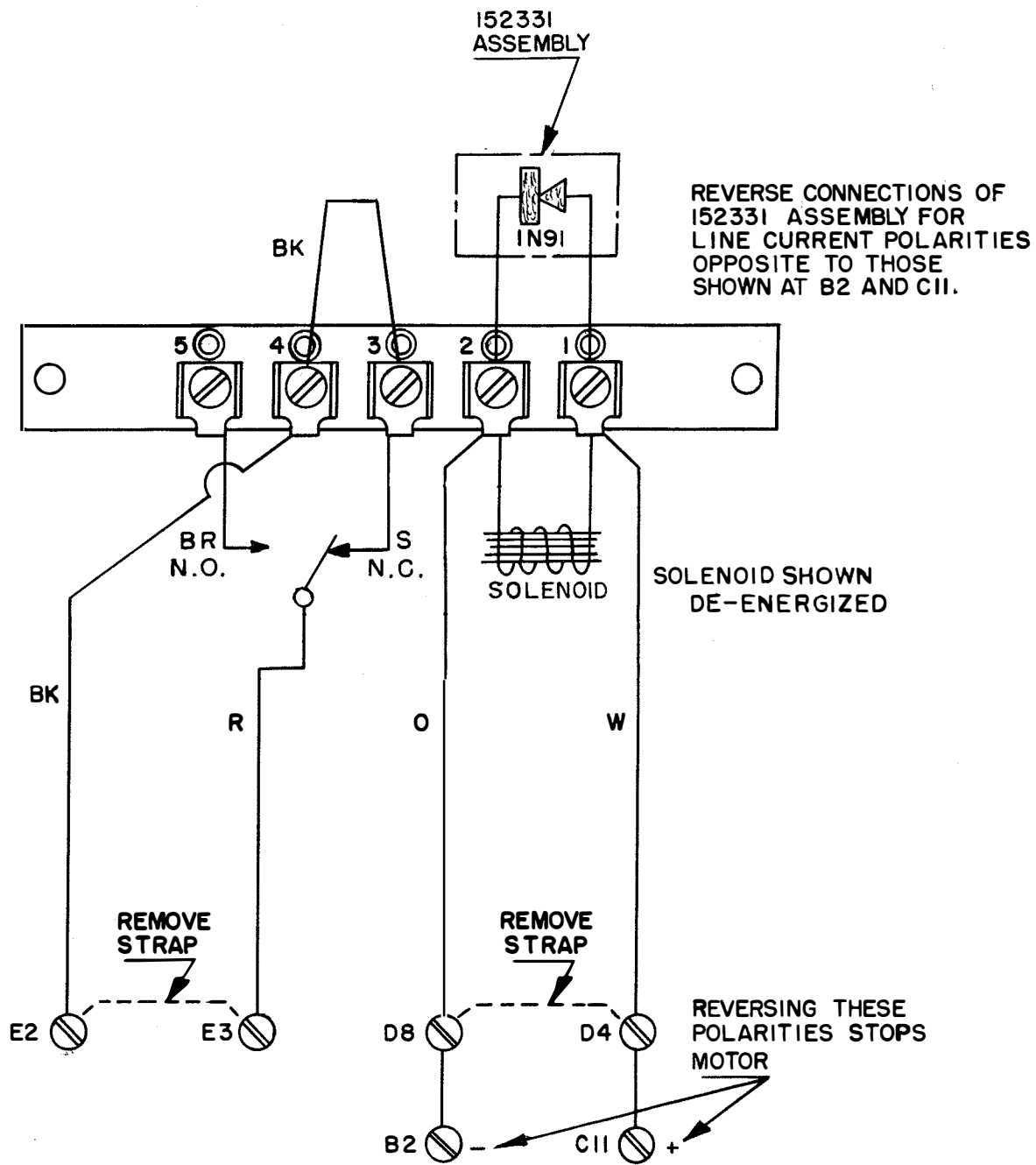

FIGURE 2

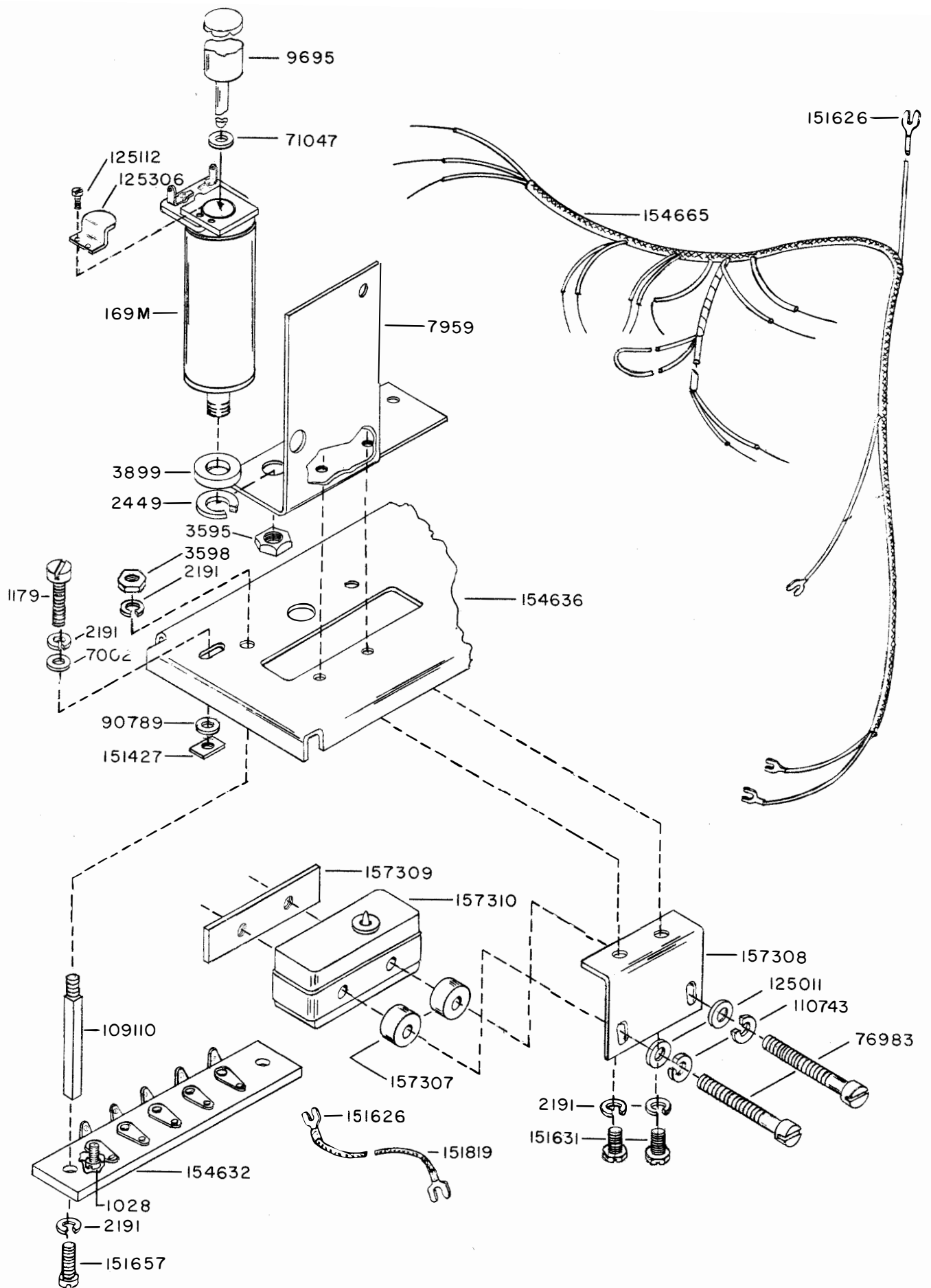

FIGURE 5-13. 152332 RELAY MOTOR CONTROL ASSEMBLY

12. MOTOR CONTROL RELAY MECHANISM

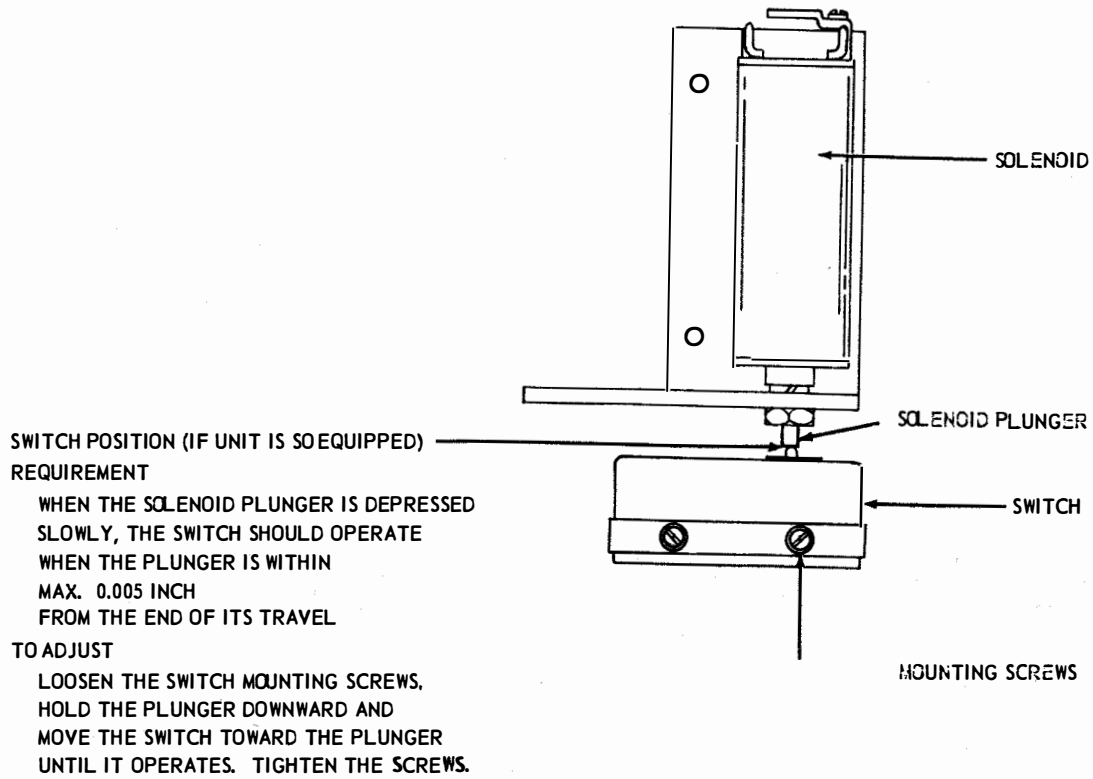

FIGURE 136 ELECTRICAL SERVICE UNIT, MOTOR CONTROL RELAY