

INSTRUCTIONS FOR ADDING A 430400 PAPER WINDER  
TO A FRICTION FEED 42 OR 43 TELEPRINTER

CONTENTS	PAGE
1. GENERAL .....	1
2. DESCRIPTION .....	1
TECHNICAL DATA .....	2
3. OPERATION .....	2
4. INSTALLATION .....	2
TABLETOP ONLY .....	3
PEDESTAL BASED ONLY .....	4
INSERTION OF PAPER WINDER .....	4
5. ADJUSTMENTS .....	5
Paper spool endplay .....	6
Sensing arm .....	7
Mercury switch .....	7
Clutch torque .....	8
Low motor torque .....	8
High motor torque .....	9
6. LUBRICATION .....	9
7. TROUBLESHOOTING .....	11
8. WIRING .....	11
9. PARTS .....	13
NUMERICAL INDEX .....	19

1.02 The 430400 paper winder is a self contained unit intended to be attached to any 42 or 43 Friction Feed Teleprinter. However, the winder may be used with any friction feed printer operating at a line feed rate of 5.2 lines per second or less, provided it is suitably mounted.

1.03 Use of the winder should be limited to single ply paper.

*Note:* When ordering replaceable parts or components, unless otherwise specified, prefix each part number with the letters "TP" (ie, TP410055).

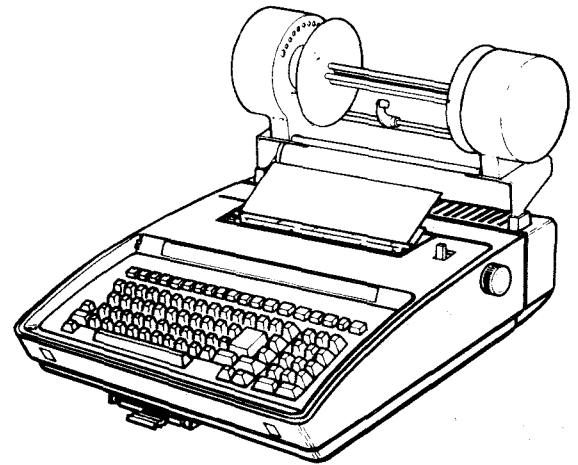

Fig. 1

1. GENERAL

1.01 This specification includes description, installation, adjustments, lubrication, troubleshooting, wiring and parts for the 43 paper winder (430400). This information provides all the servicing and repair required for the paper winder.

2. DESCRIPTION

2.01 The paper winder consists of a winder frame, paper spool and mounting hardware.

2.02 The paper spool consists of a two-piece spindle with plastic flanges. The spindle can be easily separated for paper removal.

# SPECIFICATION 51035S

2.03 The paper winder also includes a sensing arm mechanism, a mercury switch and a 2-stage (high-low) slide resistor for controlling the torque of the winder motor.

## TECHNICAL DATA

### 2.04 Electrical Characteristics

- (a) Voltage ..... 115 volts ac  $\pm 10\%$ ,  
50/60 Hz single phase
- (b) Power dissipation at full load..... 45 watts

### 2.05 Physical Characteristics

- (a) Dimensions ..... 10-1/2" high  
6-1/4" deep  
17-1/2" wide
- (b) Weight..... .6 lbs (unpacked)
- (c) Paper capacity..... 5" dia roll,  
single ply,  
approximately 490' long,  
not more than 4-1/2 lbs,  
8-7/16" wide.

## 3. OPERATION

3.01 The drive motor, located on the winder frame, provides the power for winding the paper from the printer onto the paper spool. A slip clutch equipped with a drive brace with hub, mounted on the motor shaft, supports one end of the paper spool and provides the motion to it through the motor shaft. The brace is driven through a drive disc that is between two clutch washers. A friction sleeve, disc, spring, and nut apply pressure on the drive disc through the two clutch washers.

3.02 A provision termed the "stalled" motor concept is used for controlling the output torque of the clutch. A sensing arm follows the change in the diameter of the paper roll. At a 3 inch diameter roll, a mercury switch is activated, transferring low torque to high torque by means of a 2-stage slide resistor. A slack paper condition allows the motor to rotate the drive brace which

rotates the paper spool. A taut paper condition holds the drive brace stationary and essentially "stalls" the motor. The motor having a determined amount of voltage applied to it by the resistor is readied for immediate rotation. Spent paper may be pulled back off the paper spool, overcoming the clutch torque or the internal gearing within the motor, allowing the copy to be viewed.

3.03 The paper winder has been factory adjusted for operating at 60 hertz. For 50 hertz operation, the low and high resistor values must be readjusted to meet the specified torque requirements shown in LOW MOTOR TORQUE and HIGH MOTOR TORQUE adjustments.

## 4. INSTALLATION

*Note:* If the teleprinter is equipped with the 430310 copyholder: Tabletop, remove the bustle cover and go to 4.09: Pedestal Based, do not remove bustle cover, go to 4.12.

4.01 Remove the bustle cover and remove the printer from its housing using the appropriate service manual.

4.02 Attach the 430301 left retaining mount to the 430303 left mounting bracket using two 430343 self-tapping screws. See Fig. 2. Note location of the embossed letter "L" on the 430301 left retaining mount.

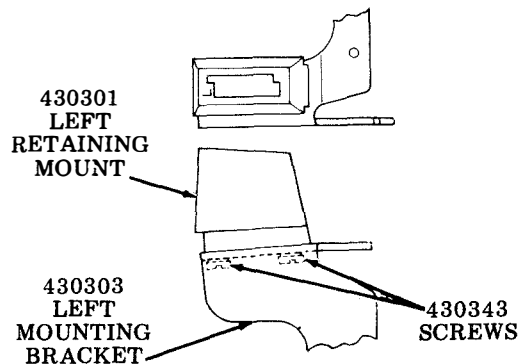

Fig. 2

4.03 Attach the 430302 right retaining mount to the 430304 right mounting bracket using two 430343 self-tapping screws. See Fig. 3. Note location of the embossed letter "R" on the 430302 right retaining mount.

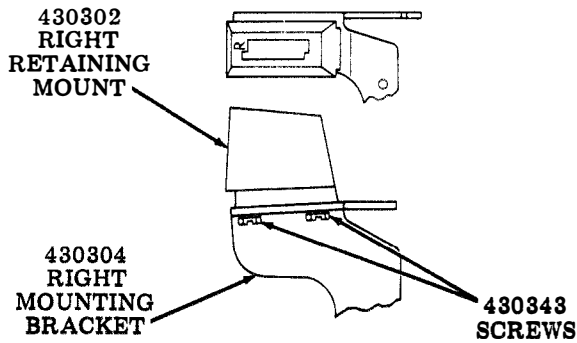

Fig. 3

4.04 Attach the 430304 right mounting bracket to the 430036 printer rear frame by hooking the lower slot of the mounting bracket under the lip of a slide projection of the printer rear frame and fasten it to the top formed edge of the rear frame using two 184056 screws. See Fig. 4.

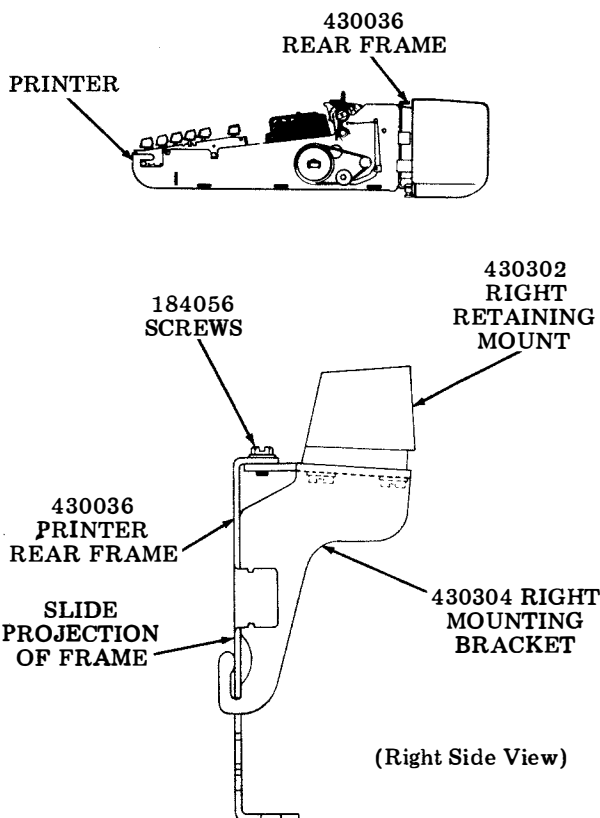

Fig. 4

4.05 Attach the 430303 left mounting bracket to the 430036 printer rear frame in the same manner used to mount the 430304 right mounting bracket (in 4.04) except on the opposite side of the printer.

4.06 The teleprinter bustle cover has two breakout sections on the underside of the cover which must be removed. These breakouts are grooved so as to guide the breaking out of these sections. See Fig. 5.

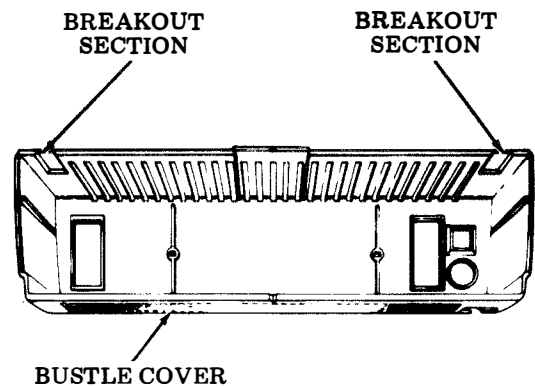

Fig. 5

4.07 To breakout each section, use a pair of long nose pliers or a pair of parallel grips and engage the section as far back as possible. Wiggle the pliers up and down, slightly at first, then gradually increase the motion until the section is completely removed. The edges of the bustle cover can be cleaned up using cutters, an industrial knife or a file.

4.08 Replace the printer.

*Note:* If the teleprinter is mounted on a 43 pedestal, replace bustle cover and paper supply assembly and go to 4.12.

TABLETOP ONLY

4.09 Insert the projection of the 430345 support into the rectangular hole in the bottom of the bustle cover as shown in Fig. 6.

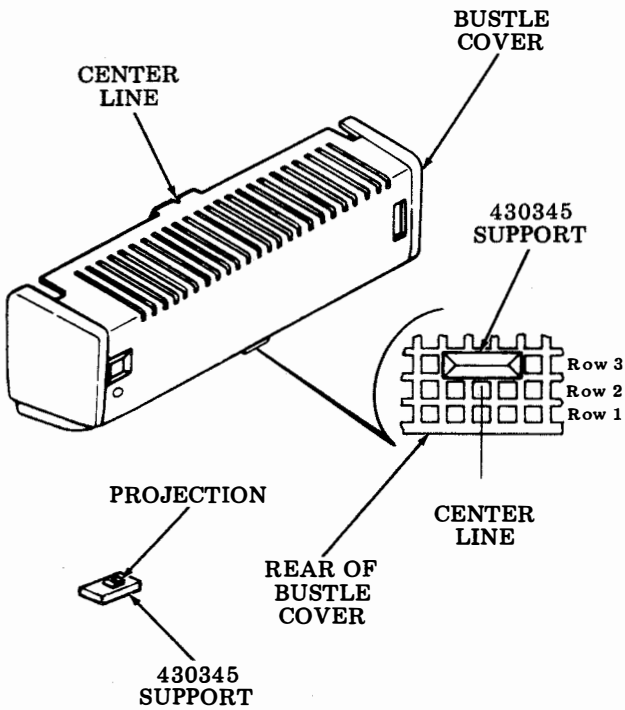

Fig. 6

4.10 Fasten the 430345 support to the bustle cover using a 430342 screw and a 85762 washer. See Fig. 7.

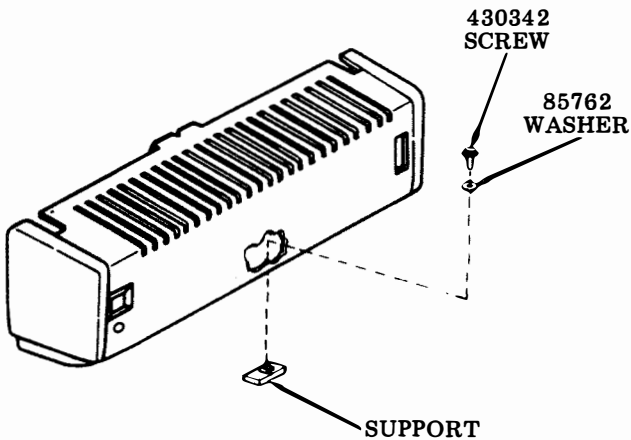

Fig. 7

4.11 Replace the bustle cover and paper supply assembly and go to 4.16.

PEDESTAL BASED ONLY

4.12 Measure the length of the pedestal legs as shown in Fig. 8. If the legs are 22-3/4 inches long, go to 4.16. If the legs are 19-1/2 inches long they must be replaced by longer pedestal legs (430458) and new bolt with cap (430457) to provide stability when using the paper winder.

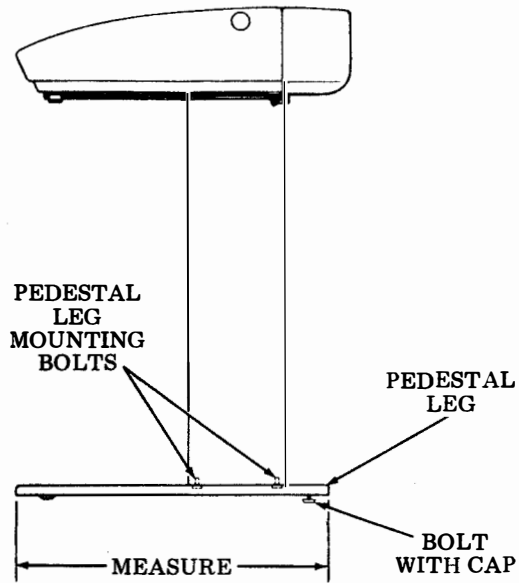

Fig. 8

4.13 The 430458 legs (2) and 430457 bolt with cap (2) are not part of this modification kit and must be ordered separately.

4.14 Thread the 430457 bolt with cap into the 430458 leg. Remove the two bolts mounting the early design leg to the pedestal. See Fig. 8. Replace with the late design pedestal legs and fasten with the bolts previously removed.

4.15 Level the pedestal by adjusting the two bolts with cap on the pedestal legs.

INSERTION OF PAPER WINDER

4.16 Insert the paper winder into the inside slots of the left and right retaining mounts. If the teleprinter is equipped with the 430310 copyholder, the copyholder fits into the outside slots of the left and right retaining mounts. See Fig. 9.

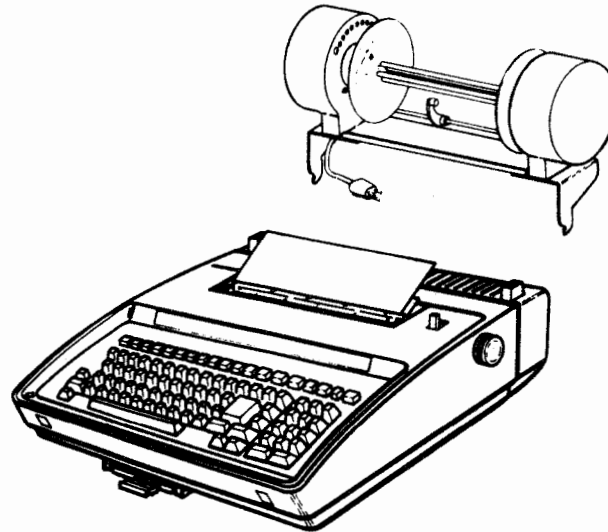

Fig. 9

4.17 Connect the paper winder power cord to a properly polarized and grounded source of 115 Vac power (50 or 60 Hz).

5. ADJUSTMENTS

5.01 Remove paper winder motor cover and clutch cover when making the following adjustments. See Fig. 10.

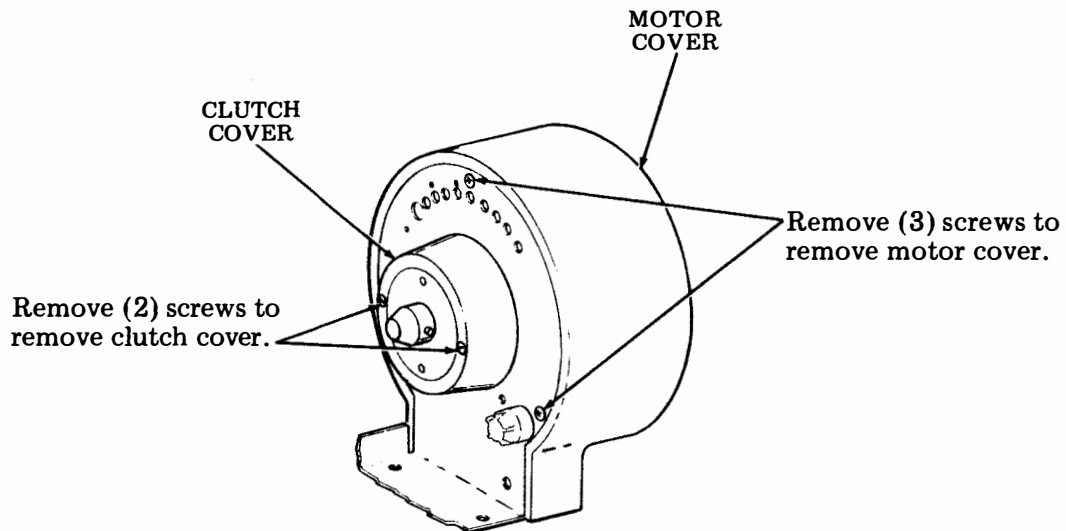

Fig. 10

PAPER SPOOL ENDPLAY

Requirement

With the plastic pilot seated in the retainer spring on the right and the drive pin seated in the spool hub on the left, there should be a clearance of

Min Some---Max 0.040 inch

between the plastic pivot and frame when the endplay in the motor shaft is taken up to make the clearance a minimum.

To Adjust

Loosen the two setscrews that secure the clutch assembly to the motor shaft. Position the clutch assembly to meet the requirement. Tighten both setscrews. Check that the spool drive pin seats in the spool hub and that the spool rotates freely through the complete revolution.

*Warning: Do not distort the vertical ends of the winder frame when making the adjustment.*

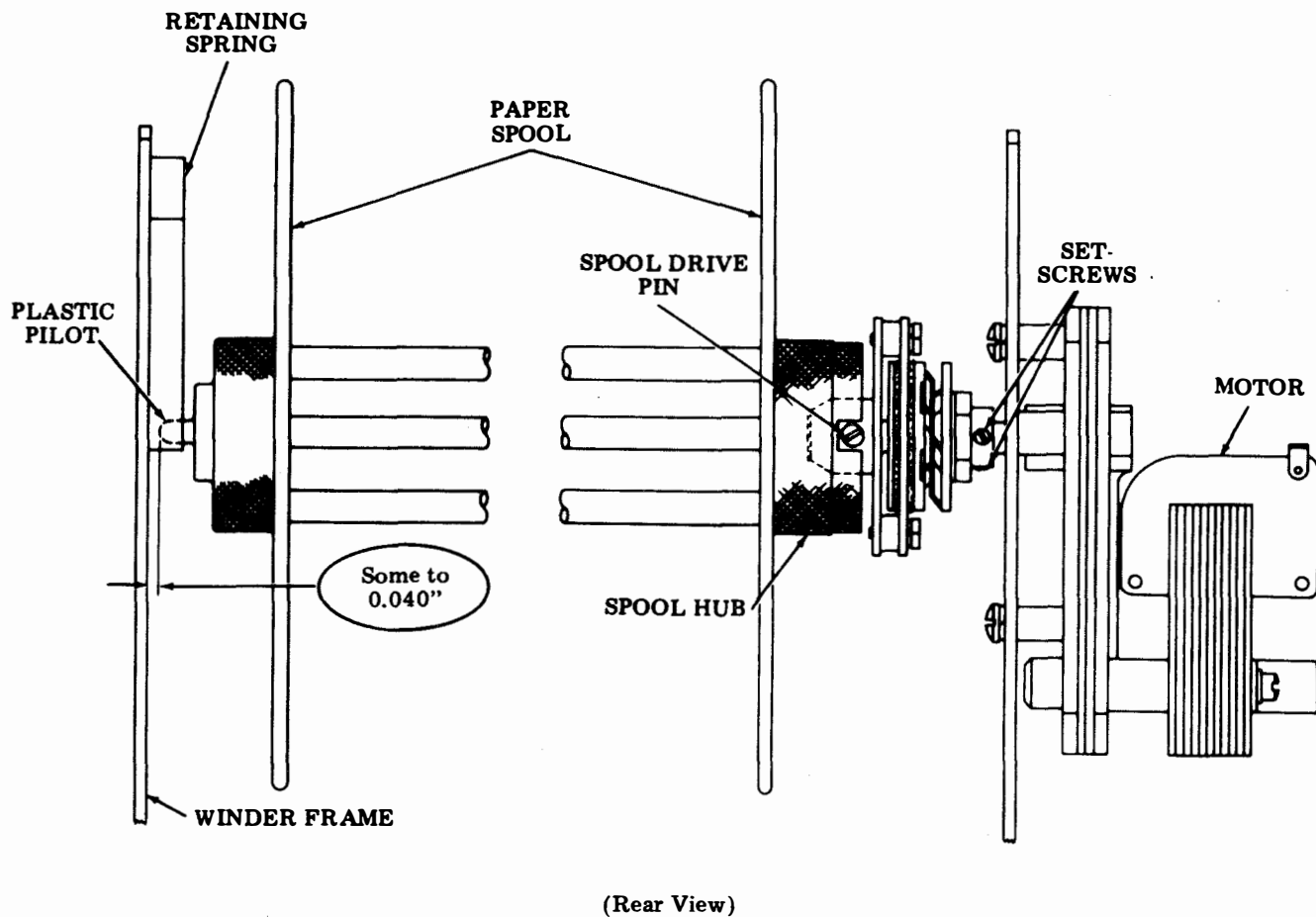

SENSING ARM

**Requirement**

With an empty paper spool installed in the winder and the stop lever engaging its stop post, there should be approximately 1/8 inch gap between closest paper spool rod and sensing arm extension post.

**To Adjust**

With setscrews associated with sensing arm friction tight, position arm to meet requirement. Tighten setscrews.

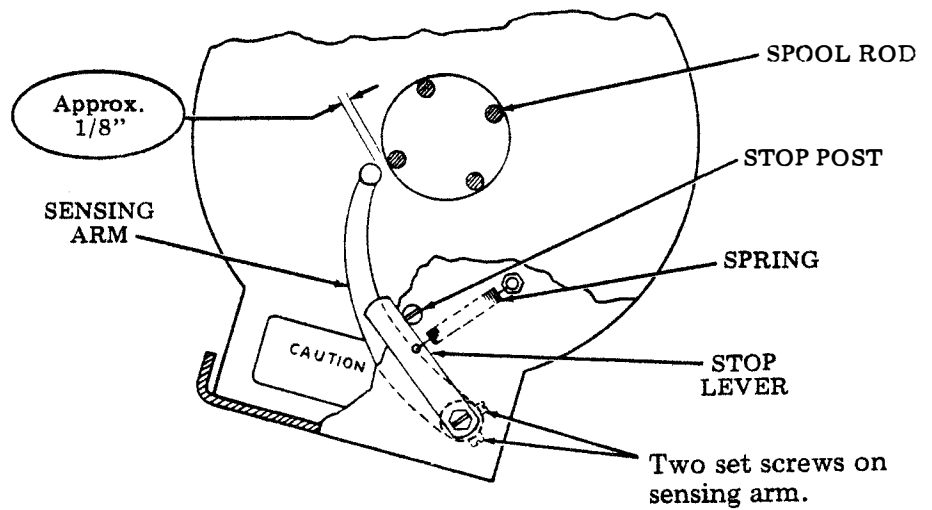

(Right Side)

MERCURY SWITCH

**Requirement**

The mercury switch should be activated to the ON position at a Min 3 inch---Max 3-1/2 inch roll diameter.

*Danger: Adjustment to be made with unit in the OFF condition.*

**To Adjust**

With mercury switch friction tight and sensing arm rotated to obtain a 3 inch to 3-1/2 inch roll diameter, position switch to a point of just making contact. Tighten screw and recheck requirement.

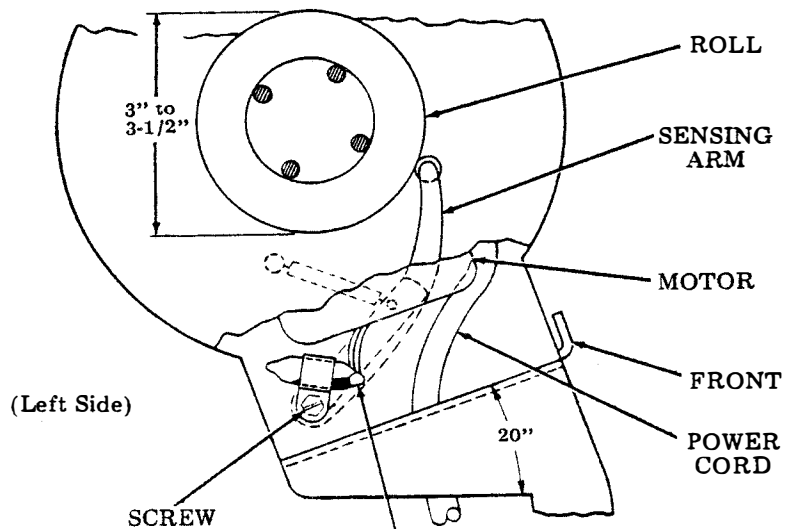

(Left Side)

Mercury switch in the ON position (high torque).

# SPECIFICATION 51035S

## CLUTCH TORQUE

### Requirement (Preliminary)

With motor side of the clutch in a locked position (use spanner wrench on friction nut) and spring scale hook applied over one of the spacers on the clutch, it should require

Min 40 ounces--Max 50 ounces  
to move drive flange.

*Note:* Take up play in direction of pull before reading scale.

### To Adjust

Loosen locknut. Rotate friction nut in or out to meet requirement. Tighten locknut.

### Requirement (Final)

After installing the clutch on motor shaft, and operating unit for a period of time, clutch torque should measure

Min 25 ounces.  
If below 25 ounces, readjust clutch.

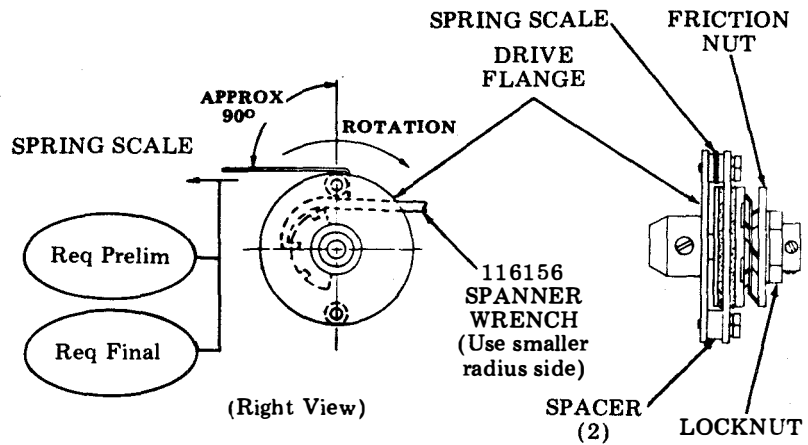

## LOW MOTOR TORQUE

### Requirement

With unit in the ON position, sensing arm in upper position, and spring scale hook applied into the hole of spool flange, it should require

Min 2-1/2 ounces--Max 3-1/2 ounces  
to allow the clutch to rotate.

*Note:* Apply greater spring tension than required, then relax tension to obtain values of adjustment.

*Danger:* Adjustment to be made with unit disconnected from ac line voltage.

### To Adjust

Loosen slide clamp locking screw friction tight. Position resistor slide clamp to obtain requirement. Tighten clamp screw. (To prevent damage to resistor, do not overtighten clamp.) Recheck requirement.

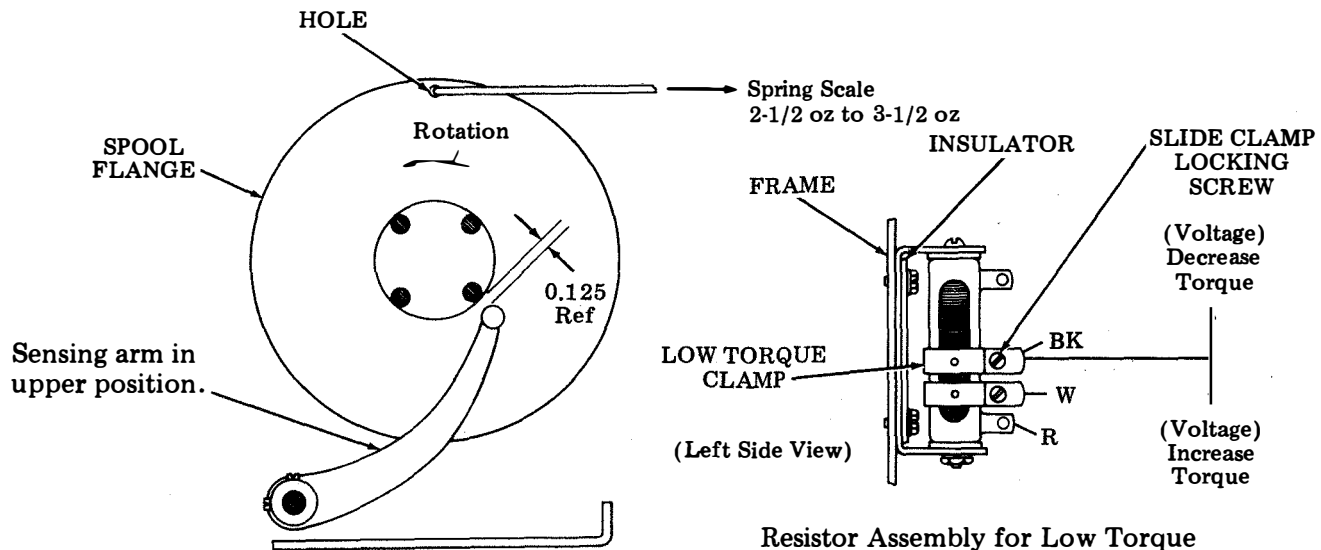



**HIGH MOTOR TORQUE**

**Requirement**

With unit in the ON position, sensing arm held down, and spring scale hook applied into the hole of spool flange, it should require  
 Min 5 ounces--Max 7 ounces  
 to allow clutch to rotate.

*Note:* Apply greater spring tension than required, then relax tension to obtain values of adjustment.

*Danger:* Adjustment to be made with unit disconnected from ac line voltage.

**To Adjust**

Loosen slide clamp locking screw friction tight. Position resistor slide clamp to obtain requirement. Tighten clamp screw. (To prevent damage to resistor, do not overtighten clamp.) Recheck requirement.

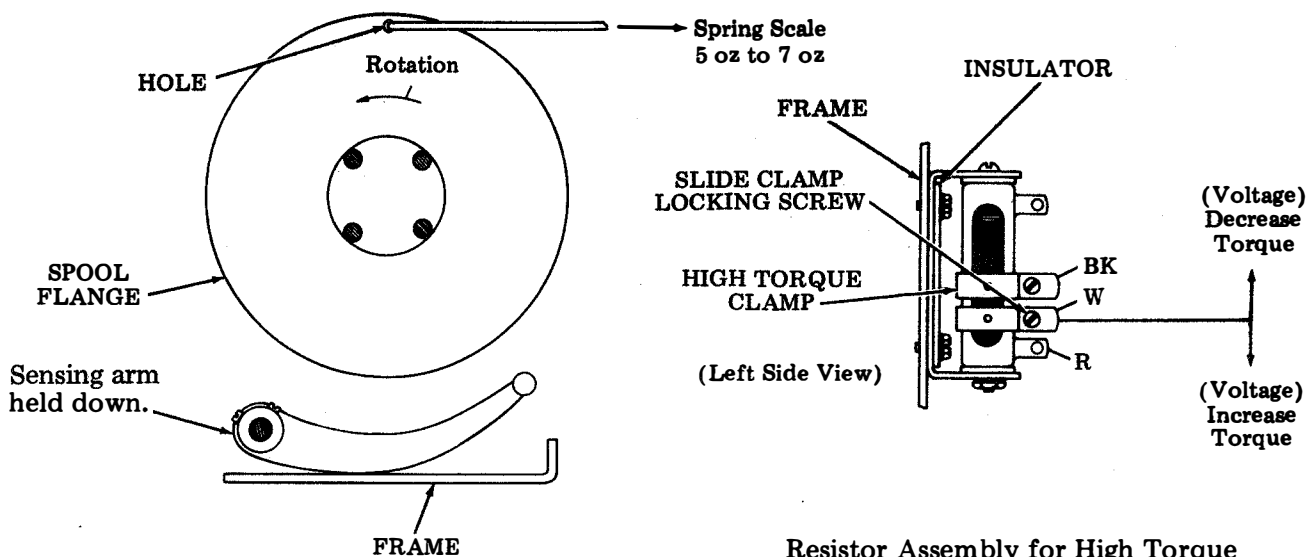

Resistor Assembly for High Torque

**6. LUBRICATION**

*Note:* Lubrication interval is 2000 hours or one year, whichever comes first.

6.01 The following symbols are used to indicate the kind and quantity of lubricant to be used in a specific area:

<u>SYMBOL</u>	<u>MEANING</u>
O2	Apply two drops of oil, 88970 (1 quart), 88971 (1 gallon).
O15	Apply 15 drops of oil, (same as above).
SAT	Saturate with oil, (same as above).
D	Dry (no lubrication permitted).

6.02 The paper winder motor cover and clutch cover must be removed to provide access to lubrication points (Fig. 11). Lubricate per Fig. 12 and 13.

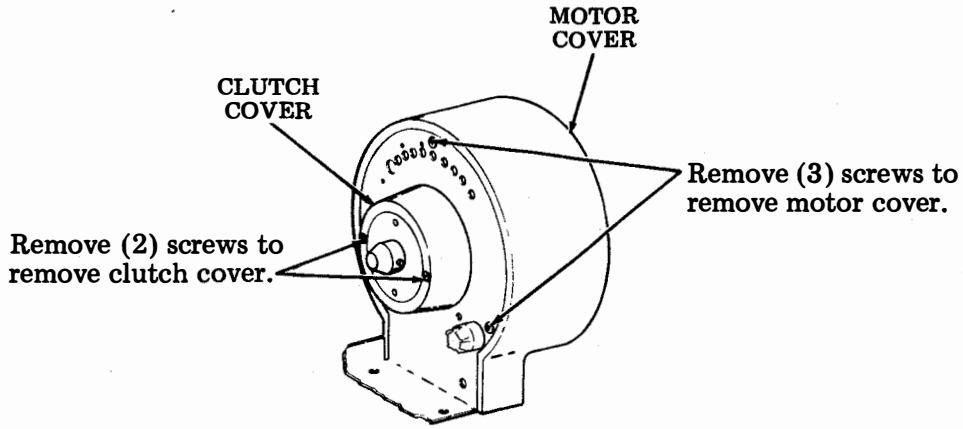

Fig. 11

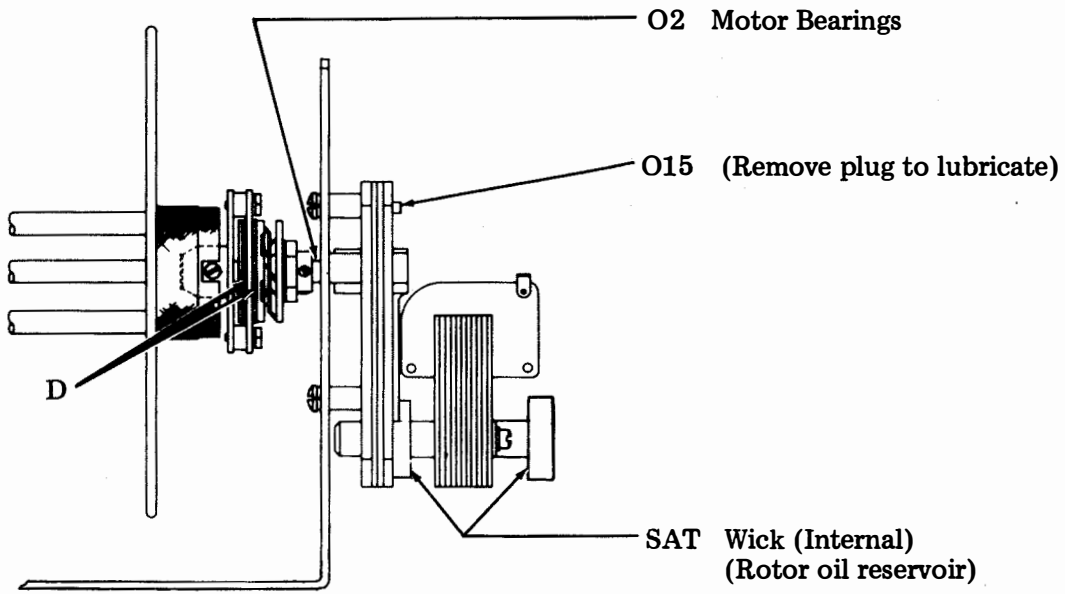

Fig. 12

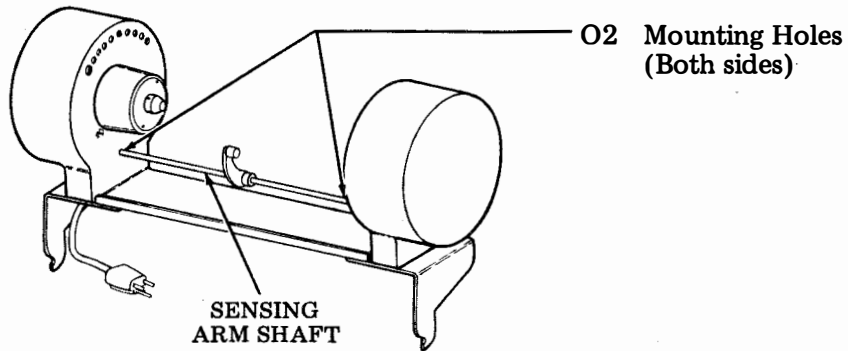
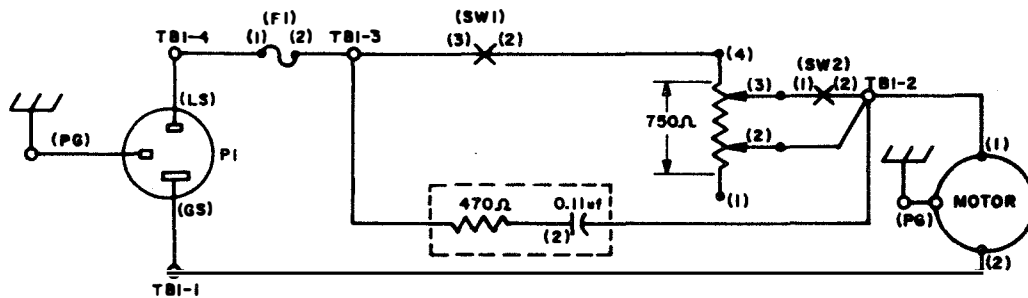

Fig. 13

7. TROUBLESHOOTING

SYMPTOM	PROBABLE CAUSE
Winder motor does not turn on. (Plugged into 115Vac and power switch on).	Check F1 fuse.
Paper too loose on paper winder (egg shaped roll).	Check CLUTCH TORQUE adjustment.  Check LOW MOTOR TORQUE and HIGH MOTOR TORQUE adjustment.
Irregular line feeding.	High motor torque crossing over before 3-inch diameter roll is on paper winder — check MERCURY SWITCH adjustment.

8. WIRING



Schematic Diagram

SPECIFICATION 51035S

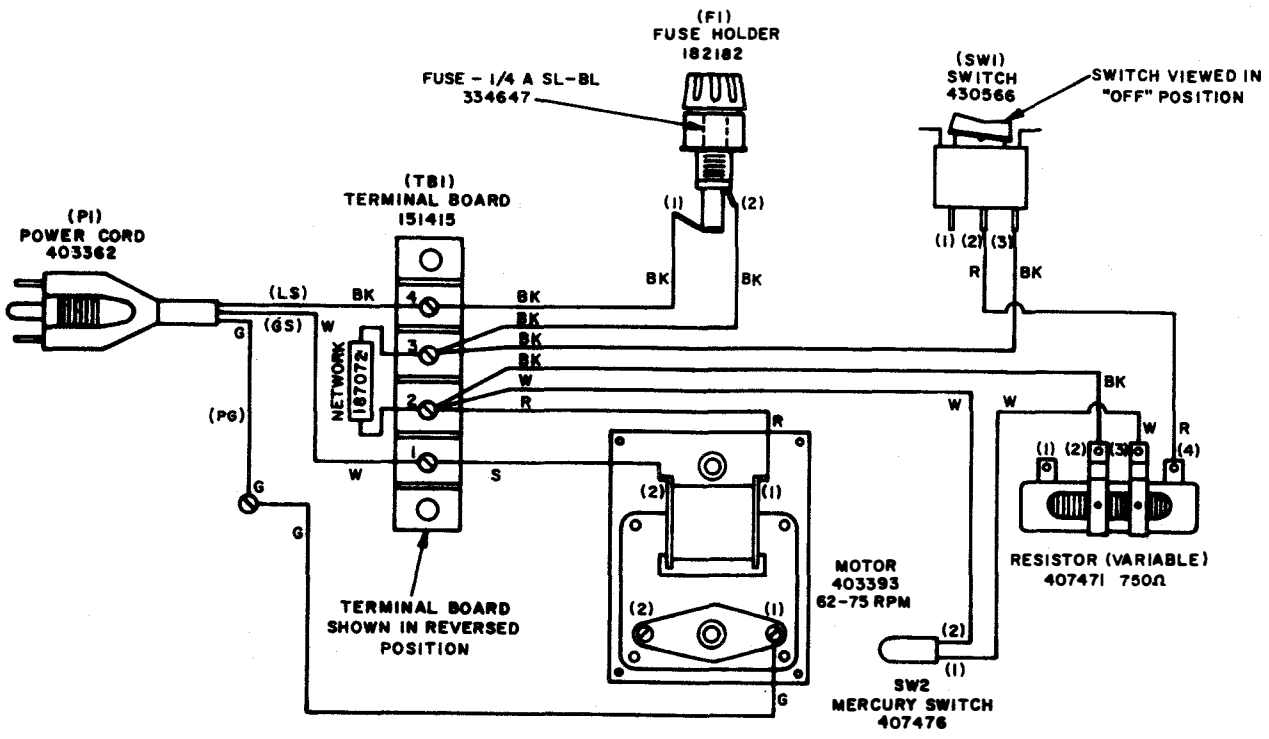

Actual Diagram

9. PARTS

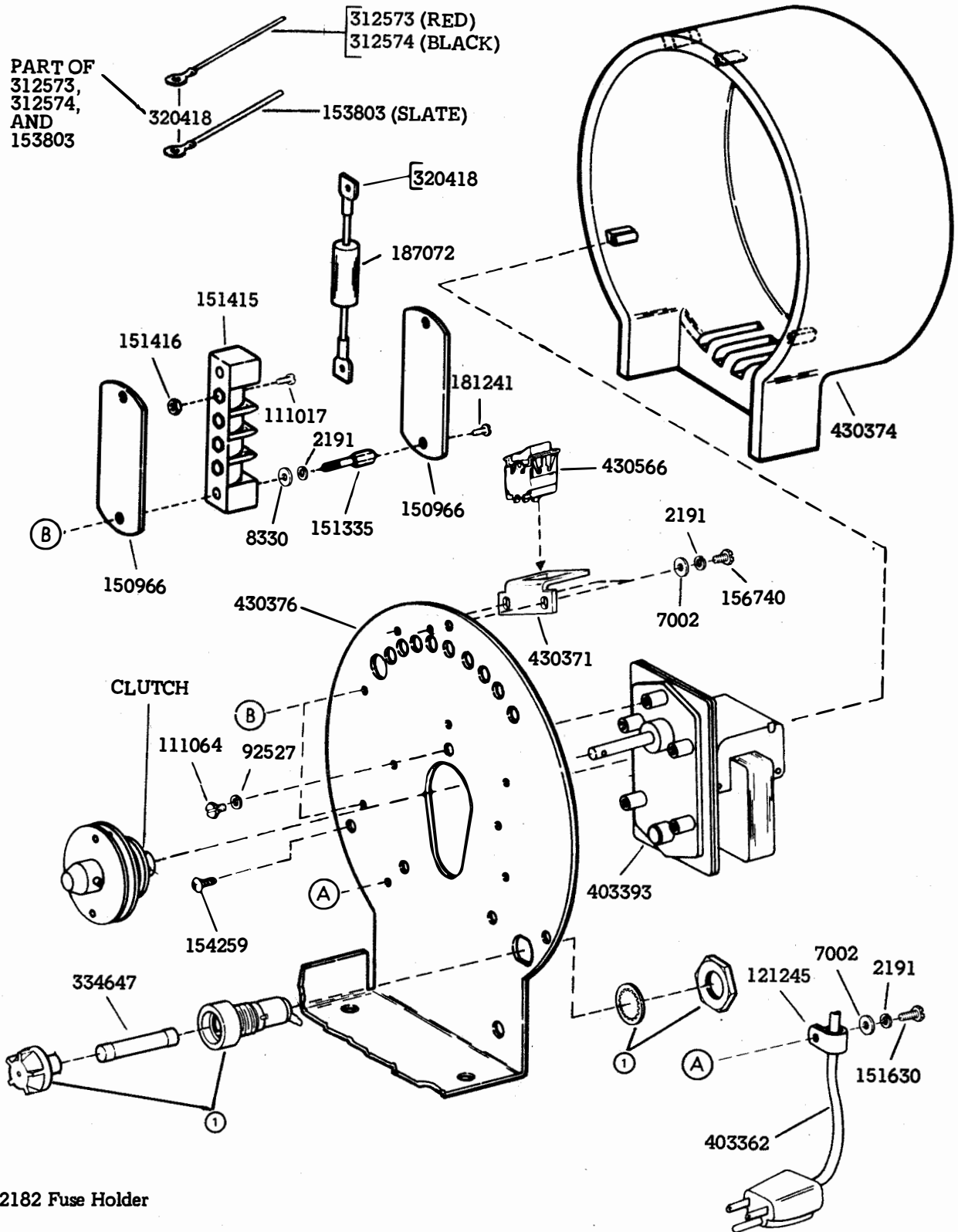

① 182182 Fuse Holder

SPECIFICATION 51035S

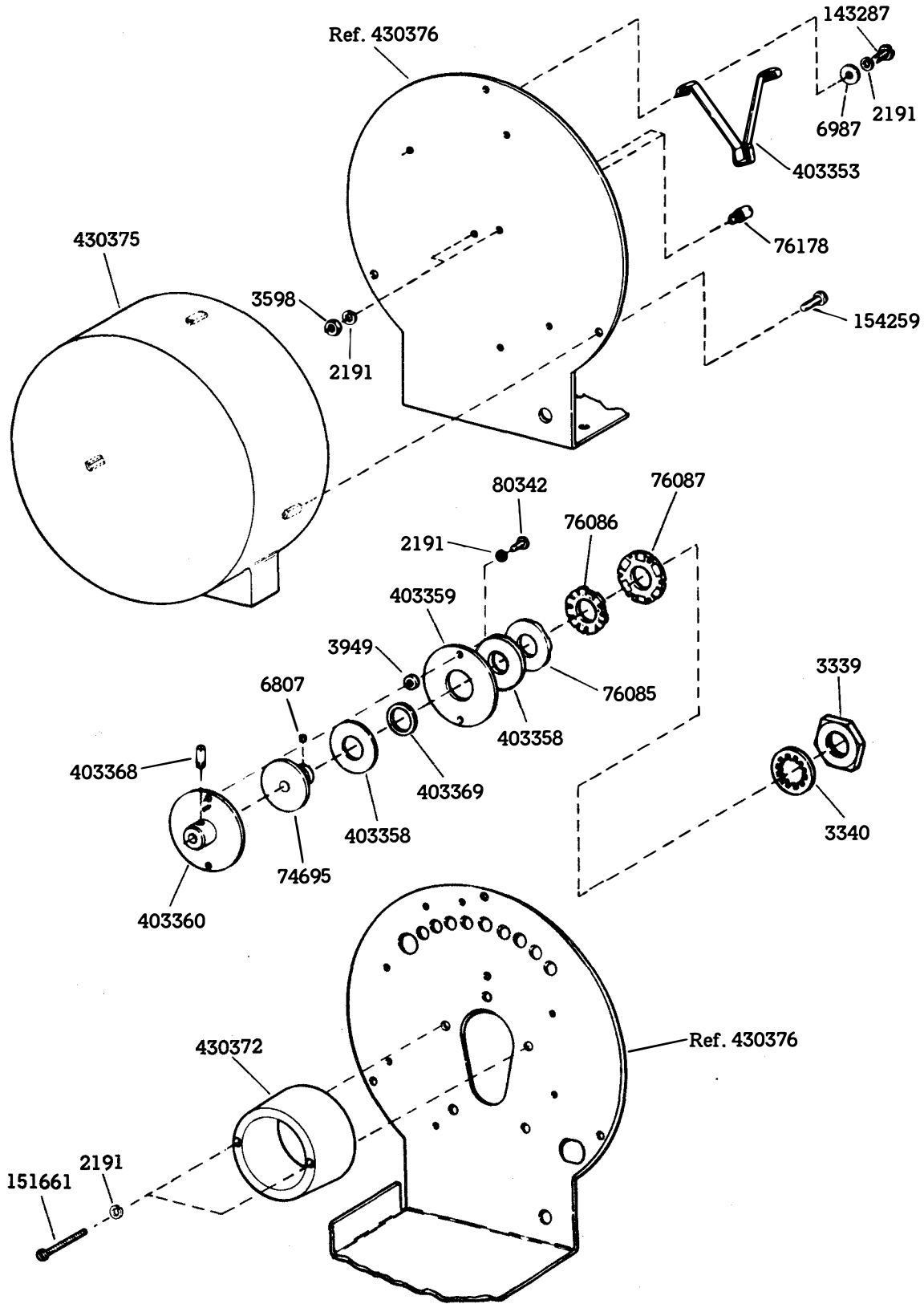

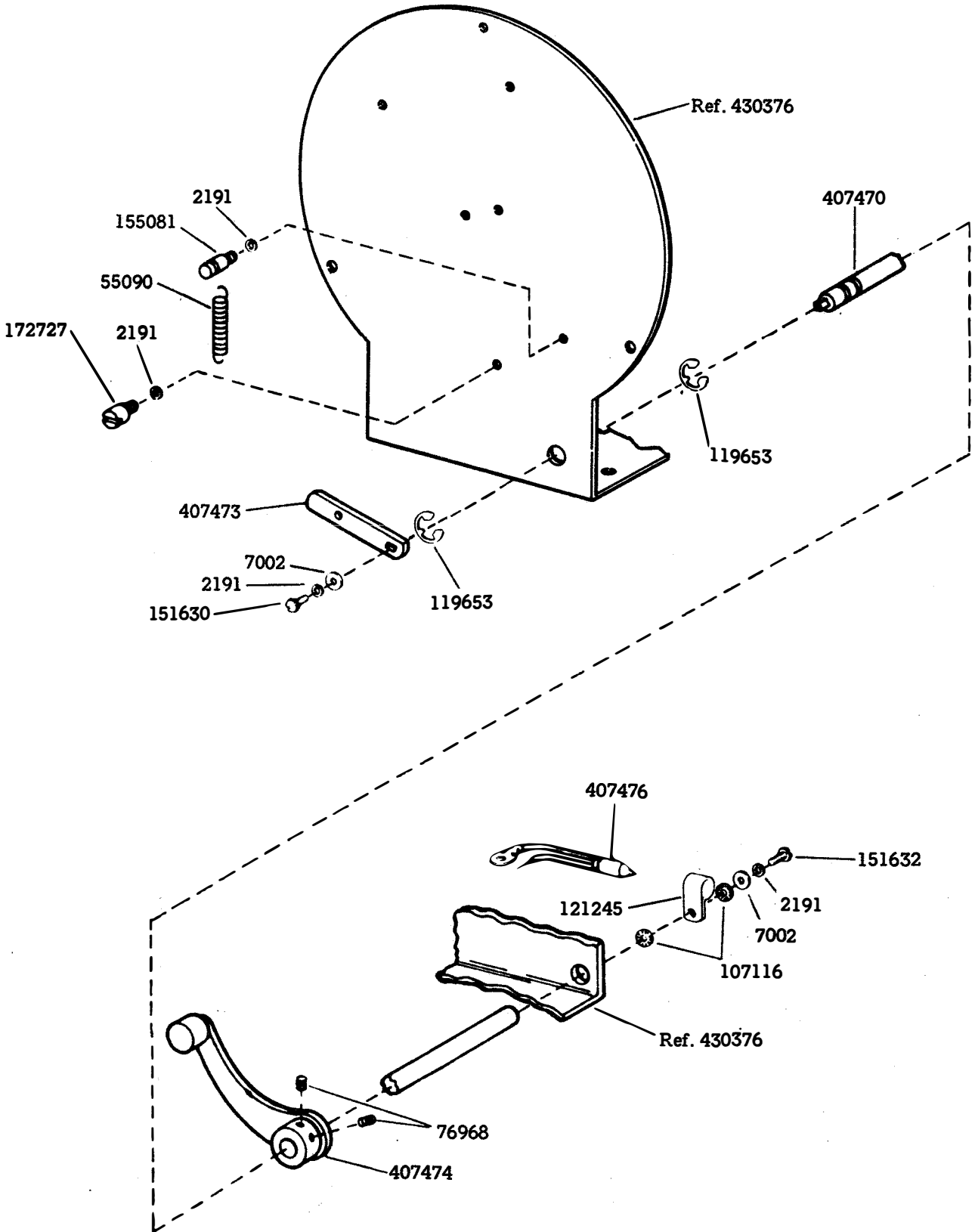

SPECIFICATION 51035S

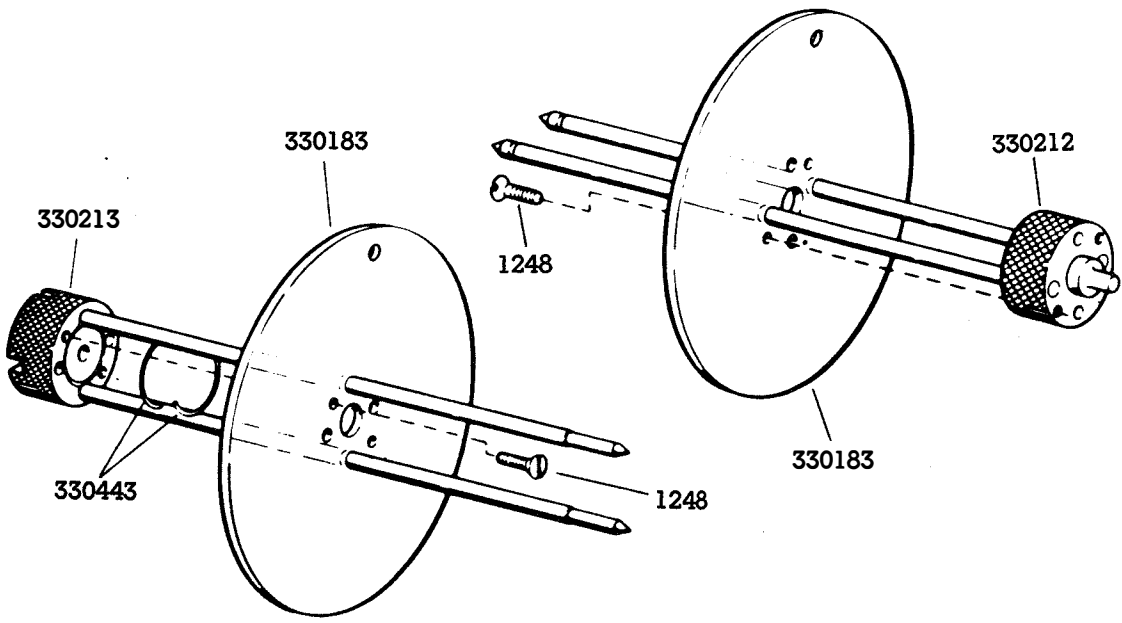
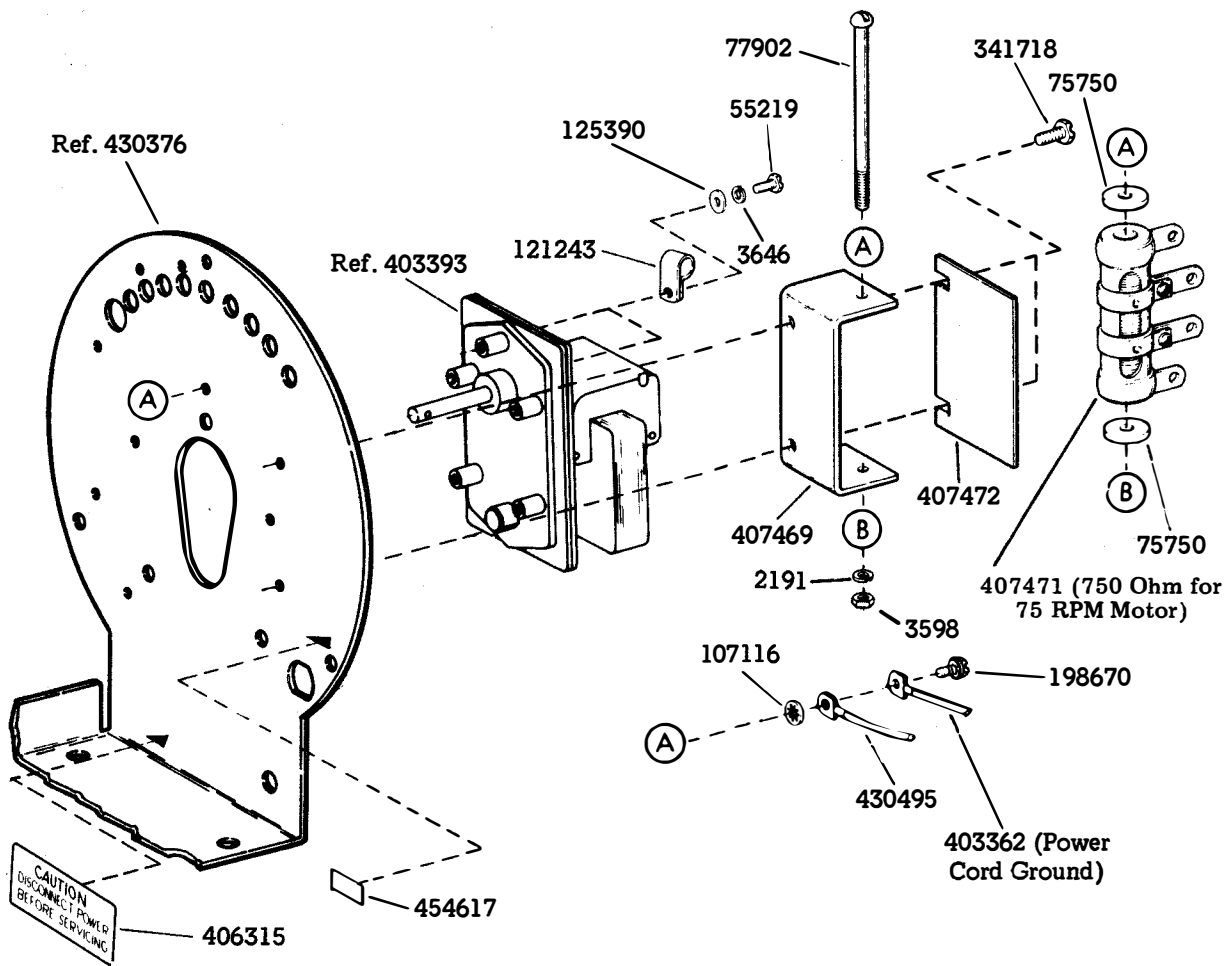



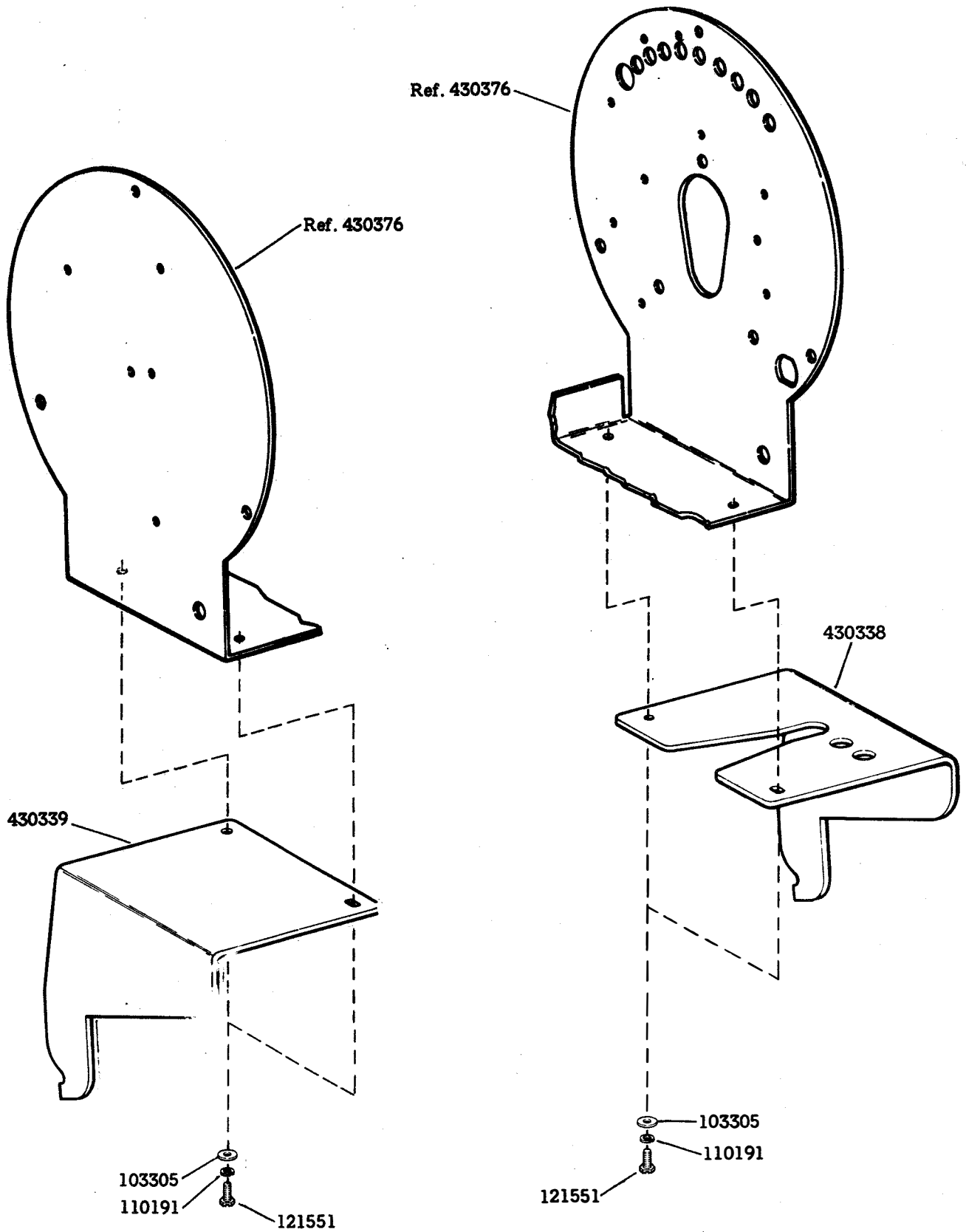

SPECIFICATION 51035S

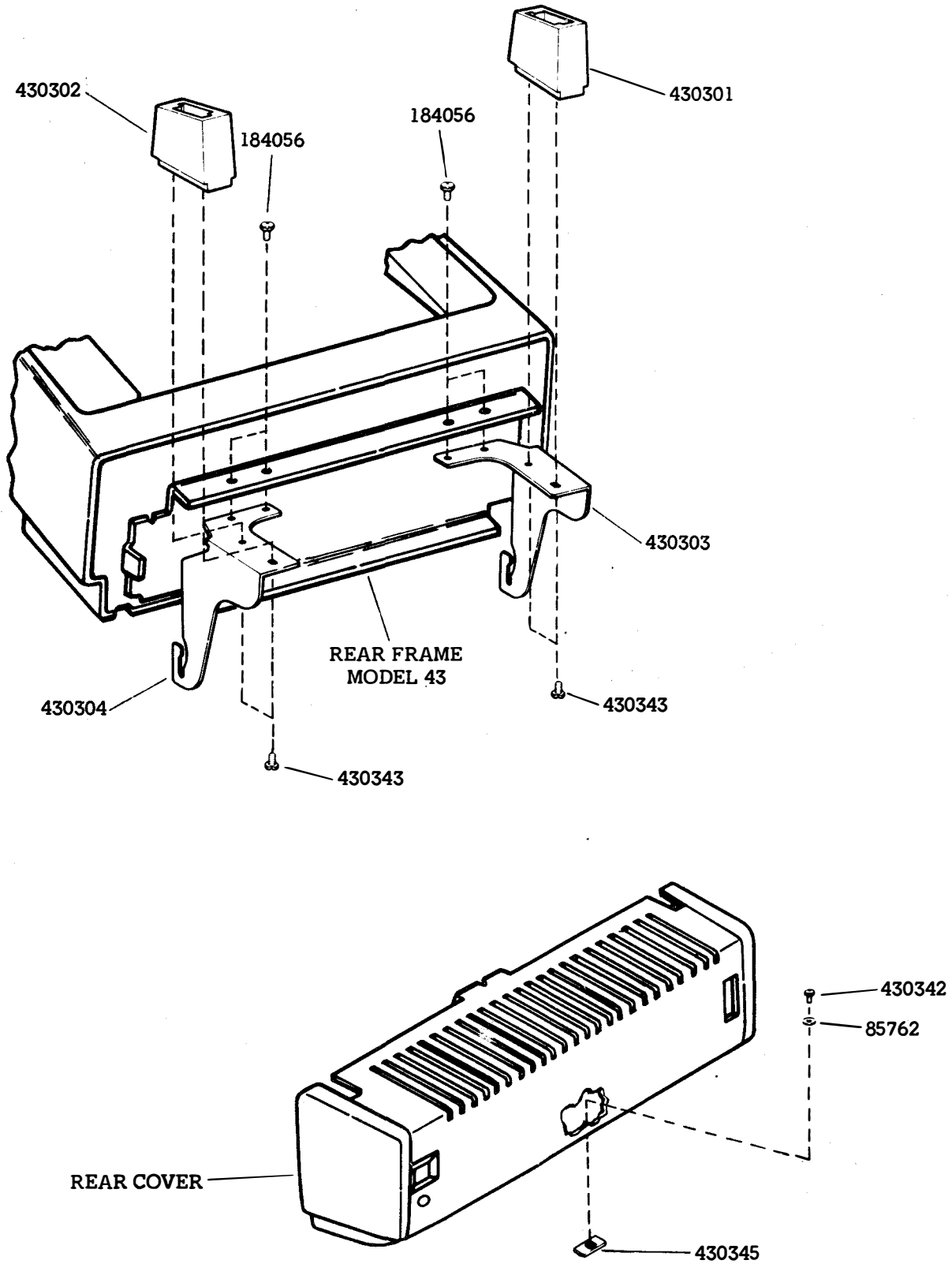

## NUMERICAL INDEX

Part Number	Description and Page Number	Part Number	Description and Page Number	Part Number	Description and Page Number
1248	Screw, 6-40 x 1/2 Flat 16	150966	Insulator, Terminal Block 13	403359	Disk, Drive 14
2191	Lockwasher 13,14,15,16			403360	Brace, Drive 14
3339	Nut, 9/16-32 Hex 14	151415	Block, Terminal 13	403362	Cord Assembly 13,16
3340	Lockwasher 14	151416	Nut, 6-40 Hex 13	403368	Post 14
3598	Nut, 6-40 Hex 14,16	151630	Screw, 6-40 x 1/4 Hex 13,15	403369	Bearing 14
3949	Spacer, .160 In Thk 14			403393	Motor 13,16
6807	Setscrew, 6-40 14	151632	Screw, 6-40 x 3/8 Hex 15	406315	Label 16
6987	Washer, Flat 14	151661	Screw, 6-40 x 1 Fil 14	407469	Bracket 16
7002	Washer, Flat 13,15	153803	Jumper, 5 In Slate 13	407470	Shaft 15
8330	Washer, Flat 13	154259	Screw #6Z Self-Tapping 13,14	407471	Resistor, 750 Ohm 16
55090	Spring 15			407472	Insulator 16
55219	Screw, 8-32 x 3/8 Fil 16	155081	Post, Spring 15	407473	Lever 15
74695	Sleeve, Clutch 14	156740	Screw, 6-40 x 7/32 Hex 13	407474	Arm 15
75750	Washer, Insulating 16	172727	Post 15	407476	Switch 15
76085	Disc, Friction 14	181241	Screw w/Lockwasher 6-40 x 1/4 Hex 13	430301	Mount, Left Retaining 18
76086	Washer, Spring 14			430302	Mount, Right Retaining 18
76087	Nut, 9/16-32 Friction 14	182182	Holder, Fuse 13	430303	Bracket, Left 18
76178	Stud 14	184056	Screw w/Lockwasher 6-40 x 1/4 Hex 18	430304	Bracket, Right 18
76968	Setscrew, 6-32 15			430338	Bracket, Left 17
77902	Screw, 6-40 x 2-3/8 Rd 16	187072	Network 13	430339	Bracket, Right 17
80342	Screw, 6-40 x 23/64 Hex 14	198670	Screw w/Lockwasher, 6-40 x 5/16 Hex 16	430342	Screw, 5/16 Self-Tapping 18
85762	Washer, Flat 18				
92527	Lockwasher 13	312573	Jumper, 6" Red 13	430343	Screw, 3/8 Self-Tapping 18
103305	Washer, Flat 17	312574	Jumper, 6" Black 13	430345	Support, Weight 18
107116	Lockwasher 15,16	320418	Terminal, Ring Type 13	430371	Bracket, Switch 13
110191	Lockwasher 17	330183	Flange 16	430372	Cover 14
111017	Screw, 6-40 x 5/16 Fil 13	330212	Pad, Back 16	430374	Cover, Left Winder 13
111064	Screw, 8-32 x 3/8 Rd 13	330213	Flange, Left 16	430375	Cover, Right Winder 14
119653	Ring, Retaining 15	330443	Spring 16	430376	Frame 13,14,15,16,17
121243	Clamp, 3/16 ID Cable 16	334647	Fuse 13	430495	Strap, 8" Lg 16
121245	Clamp, 5/16 ID Cable 13,15	341718	Screw w/Lockwasher, 6-40 x 5/16 Hex 16	430566	Switch, Rocker 13
121551	Screw, 8-32 x 1/4 Hex 17			454617	Plate, Fuse 16
125390	Washer, Flat 16	403353	Spring, Retainer 14		
143287	Screw, 6-40 x 13/32 Hex 14	403358	Washer, Clutch 14		