

INSTRUCTIONS FOR INSTALLING THE 312350
MODIFICATION KIT TO OPERATE MODEL 35
PRIVATE LINE SETS WITH DATAPHONE AND
PRIVATE LINE DATA SETS

1. GENERAL

- 1.01 The 312350 modification kit which includes the 312418 data set coupler provides for the interconnection of Teletype Model 35 terminal equipment and data sets which conform to the standards of the Electronic Industries Association. (Reference EIA Standard RS-232-B.) In accordance with these standards, all data and control leads of the data set carry polar voltage signals.
- 1.02 The 312418 data set coupler accepts current-no-current data and control signals from the teletypewriter and converts them into suitable polar signals for use by the data set. In addition, it accepts polar data and control signals from the data set and converts them into current-no-current signals for use by the teletypewriter.
- 1.03 The 312418 coupler is approximately 8-3/8 inches by 4-3/8 inches by 3-1/2 inches. The unit weighs approximately 3 pounds. The coupler may be mounted in any area suitable to the specific teletypewriter with which it is used. Mounting holes are provided on the coupler for panel mounting, relay rack mounting, or it may be set on a shelf without mounting provisions, if permissible. The coupler may be oriented in any position desired without affecting operation. Figure 1 illustrates the device and provides dimensions for the mounting holes provided.
- 1.04 The 312350 modification kit is used with Bell System Data Sets 103A, 103E, and 103F all of which use the EIA interface. The kit is for use on Teletype terminal equipment, Model 35, which is used on 35AN, 35AP, 35AT, 35AU, 35AR, 35AS, 35AY, and 35AW.
- 1.05 Serialized data signals may be utilized at signaling rates up to 1200 baud.
- 1.06 All data and control signals between the data set coupler and data set are polar. The coupler is sensitive to received signals of +3 to +25 volts dc and sends signals of +5 to +25 volts dc to the data set.
- 1.07 The 312418 coupler provides coupling facilities for the following EIA and/or special interface circuits which are associated with the 103A, 103F, or 103E Data Sets:

<u>Circuit Designation</u>	<u>Description</u>	<u>Data Set</u>
AA	Protective Ground	103A, F, E
AB	Signal Ground	103A, F, E
BA	Transmitted Data	103A, F, E
BB	Received Data	103A, F, E
CA	Request to Send	103F
CB	Clear to Send	103A, F, E
CC	Data Set Ready	103A, F, E
CD	Data Terminal Ready	103A, E
CE	Ring Indicator	103A, E
CF	Data Carrier Detector	103A, F, E
CJ	Local	103F
CK	Originate	103F
CL	Send Restraint	103E

The coupler may be used with other data sets provided that the circuits conform to EIA Standards RS-232-B and that additional circuits to those shown above are not required (such as 202B data set).

- 1.08 The coupler provides the option of receiving local copy when the teletypewriter is transmitting (similar to half-duplex) or allowing remote traffic to be received when transmitting locally (similar to full-duplex).
- If the coupler is connected for half-duplex operation; a noninterfering line break feature is provided whereby, if traffic is being received by the teletypewriter, line break may be transmitted without interfering with the traffic being received.
 - If the data set is disconnected or has power off; the coupler holds circuit BB (received data) in the mark condition and circuit CB (clear to send), circuit CD (data set ready), and circuit CF (data carrier detector) in the off condition.
 - The teletypewriter may use the dc power from the coupler for alternate functions. This use is restricted to 50 ma at 40 v dc.
- 1.09 The power input to the coupler is 115 $\pm 10\%$ v ac, 60 $\pm 1\%$ Hz. This power must be provided through the twist lock connector on the coupler. A power cord is provided to connect AC power to the coupler.
- 1.10 The coupler is operable over a temperature range of 40^oF to 125^oF and a relative humidity up to 90%.
- 1.11 The average power consumption of the coupler does not exceed 50 watts.

Note: It is recommended that signal generators equipped with gold contacts be used in conjunction with this coupler. Although the circuit does accommodate a relatively high voltage drop in the BA circuit, tests have shown that tungsten contacts can exhibit complete nonconductivity under some operating conditions.

1.12 General Operating Information for Data Sets and Terminal Equipment:

(a) 103A, 103E Data Sets and 35AW, 35AN, 35AP, 35AR, and 35AS teletypewriters:

<u>Originating Station</u>	<u>Receiving Station</u>
(1) Remove handset from cradle	
(2) Push TALK button	
(3) Dial desired station after dial tone is heard	
<u>Note:</u> If a carrier tone is heard, proceed to step (5). This indicates the receiving station is in the automatic answer mode.	(1) Ringing indication
	(2) Remove handset from cradle
	(3) Push TALK button
(4) Discuss proposed transmission	(4) Discuss proposed transmission
(5) Push DATA button	(5) Push DATA button
(6) Start transmission	(6) Receive Transmission
(7) Push TALK button (after end-of-transmission)	(7) Push TALK button (after end-of-transmission)
(8) Replace handset on cradle	(8) Replace handset on cradle

(b) The terminal set may be used in a local mode by turning the power switch to LOCAL. The TALK button should be pushed to receive any incoming calls.

(c) In the AUTOMATIC ANSWER mode; the receiving terminating set will start automatically, receive the transmission, then shut off when the originating station hangs up.

SPECIFICATION 50453S

(d) When the terminal set is used ON LINE, the data set operates the motor control relay which turns on the terminal set. Data may be transmitted from the tape reader on the keyboard, and data may be received on the tape reperfector or page printer or both.

(e) In the LOCAL mode of the power switch, the data set has no control over the terminal set. The automatic answer of the data set will not operate but only present a ringing indication which requires a manual answer in the TALK mode. The terminal set will function as it did before the 312350 modification kit was installed.

(f) In the OFF mode of the power switch, the data set has no control over the terminal set. It provides a ringing indication which requires a manual answer in the TALK mode.

(g) Tape Reader Control

(1) 35AR, 35AS

a. The K1 relay operates each time a carrier tone is received from an external data set. This relay is used to control the tape reader in the automatic answer mode. The 35AR, 35AS terminal sets contain tape readers which may be utilized for this function. The K1 contact may be optionally wired in parallel or in series with the bat handle tight-tape switch to provide automatic control by the data set.

1. Connecting the K1 contact in parallel with the bat handle tight-tape switch will disable the tight-tape. The only way to stop the reader ON LINE is to remove the tape.
2. If the K1 contact is wired in series with the reader control circuit, the reader is available only ON LINE and will not operate in LOCAL.

(2) 35AW

a. The data tape reader on the 35AW is used in the ON LINE mode. Two optional arrangements are available for reader operation:

1. Normal reader operation without the need of fill characters (rubout) after horizontal tab, vertical tab, and form feed.
2. Two fill characters (rubout) are needed after horizontal tab, vertical tab, and form feed. The second option is easier to install than the first.

(h) Noninterfering Break — The 312350 modification kit is installed in the 35AR, 35AS, 35AT, 35AU, 35AN, 35AP, and 35AW private line terminal sets providing a noninterfering break. An interfering break, as an option, may be hooked up by inserting the break switch in series with the signal generator between J3-13 and J3-12 and a strap between J3-12 and J3-1.

(i) 35AN, 35AP — Local copy feature is provided if the 312350 modification kit is connected to the KSR as outlined in Part 2. The modification kit provides local battery for the selector magnet driver.

1.13 The 312350 modification kit consists of:

3	2034	Washer, flat	2	156632	Screw
4	2191	Lockwasher	1	173715	Terminal
3	3598	Nut	1	178306	Relay
2	7002	Washer, flat	1	180904	Terminal
1	76284	Strap	1	197054	Strap
1 ft.	31784RM	Wire	1	198259	Wire assembly
1	92260	Washer, star	1	199908	Strap
1	121244	Clamp, cable	1	312362	Cable assembly
1	121248	Clamp, cable	1	312418	Data set coupler
1	146420	Power cord assembly	1	312684	Wire assembly
3	151630	Screw			

1.14 For the theory of operation and the various options see Part 3 of this specification.

2. INSTALLATION (Figure 1 and Wiring Diagram 8021WD)

- 2.01 Mount the coupler on the facilities provided in the terminal apparatus.
- 2.02 Loosen the three 181242 screws and remove the 198418 cover.
- 2.03 Connect the 198419 cable between the J-2 connector and the data set.
- 2.04 The 198424 transformer should be connected to the J-1 connector.
- 2.05 Connect the 312362 cable provided by the 312350 modification kit to the J-3 and J-4 connectors.
- 2.06 Replace the cover.
- 2.07 A 121244 cable clamp, 121248 cable clamp, 181243 screw with lockwasher, and 7002 flat washer are provided in a muslin bag attached to the coupler for use by the installer to secure the 198419 cable and the 312362 cable if so desired.

SPECIFICATION 50453S

- 2.08 Remove the electrical service unit (LESU) by loosening the screw at the bottom of the left end. Push the screw to the right to release the left end of the LESU. Moving the LESU to the right will release the right end. It may be necessary to unplug the F and R connectors before turning the LESU over to reveal the underside.
- 2.09 Mount the motor control relay (178306) with two 151630 screws, two 2191 lockwashers, two 7002 flat washers, and two 3598 nuts to the underside of the LESU on the backside of the chassis using two of the holes provided.
- 2.10 The 312362 cable, which is about 6 feet long, is to be routed up the back of the terminal set to the electrical service unit. Position the long branch of the cable under the right end of the LESU and position the end of the plastic tubing of the cable below the wiring field. A 121246 cable clamp is provided to secure the cable to the right end of the LESU with the 181243 screw with lockwasher and 7002 flat washer provided. The short branch is positioned around the right end of the LESU to the signal line terminal block.
- 2.11 Connect the 18GA white lead from the 312362 cable to terminal 2 of the motor control relay. Connect the 18GA yellow lead to terminal 4 of the motor control relay. Connect the orange lead to terminal 1 of the motor control relay. Connect the white-red lead to terminal 3 of the motor control relay. Connect the black lead to the ground lug on the side of the LESU.
- 2.12 Push the remaining leads through the slot to the back side of the C wiring field.
- 2.13 The remaining wiring will differ according to the type of terminal apparatus used as follows:
- (a) With the 35AT and 35AU Receive-Only Sets (referring to wiring diagrams 6046WD, 6385WD, 7972WD, and 7973WD):
- Move E-6-Y+ from C-2H to C-3G.
Move E-7-P+ from C-3G or C-3H to C-2H.
Move E-8-S+ from C-2H to C-5E. Remove and tape F-37-W-Y if present.
Connect MCR-4-Y+ to C-5E.
Connect MCR-2-W+ to C-3G.
Connect J3-10-W-BL to C-3F.
Connect J3-13-BL to C-1B.
Connect the following dual wires with "spade" terminals to the T terminal block
J3-13-BL to T8
J3-1-R to T5

J4-3-G to T7

J3-12-W-G to T6.

Connect T6 to T8 with the strap provided.

Pull all unconnected leads back through the slot and tape each lead individually and tie back.

- (b) With the 35AN and 35AP Keyboard Send-Receive Sets (referring to wiring diagrams 6041WD, 6046WD, 7876WD, 7877WD, 7972WD, and 7973WD):

Move E-6-Y+ from C-2H to C-3G.

Move E-7-P+ from C-3G or C-3H to C-2H.

Remove F-37-W-Y, if present, from terminal C-5E and tape.

Move E-8-S+ from C-2H to C-5E.

Connect MCR-4-Y+ to C-5E. Remove and tape F-37-W-Y if present.

Connect MCR-2-W+ to C-3G.

Connect J3-10-W-BL to C-3F.

Connect J3-13-BL to C-1B.

Connect J3-12-W-G to C-3B. If local copy is not desired, do not connect J3-12-W-G.

Connect the following dual wires with "spade" terminals to the T terminal block, and tape back the remaining wire (J3-12-W-G)

J3-13-BL to T-8

J3-1-R to T-5.

J4-3-G to T-7. Remove strap from T-6 to T-7 and connect T-6 to T-8 with the strap provided.

Pull all unconnected leads back through the slot and tape each lead individually and tie back.

Note: The symbol * appearing on "applicable" wiring diagrams has been replaced in this specification by the symbol +.

- (c) With the 35AR and 35AS Automatic Send-Receive Sets (referring to wiring diagrams 6384WD, 6394WD, 7913WD, 7914WD, 7994WD, and 7995WD):

Remove the two straps connecting terminals C-M2, C-M3, and C-N3

SPECIFICATION 50453S

and replace them with a 198259 strap provided, in order to free one terminal connection point on C-3M.

Move E-6-Y+ from C-1N to C-3M.

Move E-7-P+ from C-3M to C-1N.

Connect MCR-4-Y+ to C-3M.

Remove F-32-R+, if present, from C-1N, and tape back.

Connect MCR-2-W+ to C-1N.

Connect J3-10-W-BL to C-6C.

Connect the following dual wires with "spade" terminals to the T terminal block, and tape back the remaining wire (J3-12-W-G).

J3-1-R to T-5

J4-3-G to T-7

J3-13-BL to T-8

Remove strap between T-6 and T-7, and connect T-6 to T-8 with the strap provided.

Connect J3-12-W-G and J3-13-BL as follows:

(If local copy is not desired, do not connect J3-12-W-G).

35AR or 35AS without signal regenerator

Connect J3-12-W-G to C-4E.

Move H-8-BK-S from C-4A to C-5J.

Install the 312684 strap to connect C-4A and C-5J.

Connect J3-13-BL to C-5J.

35AR or 35AS with signal regenerator

Connect J3-12-W-G to C-4E.

Remove R-38-W-BK from C-5J and tape.

Move H-8-BK-S from C-4A to C-5J.

Install the 312684 strap to connect C-4A and C-5J.

Connect J3-13-BL to C-5J.

On units so wired, move SRG-N-W-P from C-4E to C-3F.

Install the 197054 strap to connect C-4E and C-3F.

Connect J3-12-W-G to C-3F.

Move H-8-BK-S from C-5J to C-4A.

Install the 312684 strap to connect C-4A and C-5J.

Connect J3-13-BL to C-4A.

For tape reader control, proceed as follows, choosing parallel or series option:

PARALLEL: To wire control contact in parallel with bat handle tight-tape switch.

1. Connect J4-13-W to C-1K.
2. Connect J4-11-P to C-2K.

SERIES: To wire control contact in series with bat handle tight-tape switch.

1. On all 35AR or 35AS Sets, move F-20-BK-O from C-3K to C-5G. On sets so wired, move SMD1-J-W-BL from C-3K to C-5G.
2. Connect J4-13-W to C-3K.
3. Connect J4-11-P to C-5G.

Pull all unconnected leads back through the slot and tape each lead individually and tie back.

- (d) With Options 1 and 2 in the 35AW Unit (See Paragraph 1. 12 (g) (2).)

Remove strap from C-1H to C-2H.

Move E-7-P+ from C-3H to C-1H. Move E-6-Y+ from C-1H to C-3H.

Connect MCR-2-W+ to C-4H. Connect MCR-4-Y+ to C-2H.

Connect J4-11-P to C-1N (Omit for Option 2).

Connect J4-13-W to C-5R.

Connect G-43-W-O-BL to C-1N. (Omit for Option 2.)

Remove strap from T6 to T7.

Connect J3-1-R to T5. Connect J3-12-W-G to T5.

Connect J3-13-BL to T6. Connect J4-3-G to T7.

Connect J3-10-W-BL to C-4K. Connect T8-BL to C-5C.

Connect T6 to T8.

Connect G-43 to N-21 with the 173715 terminal and 31784RM hook up wire provided. (Omit for Option 2.)

- (e) With Option 2 in the 35AW Unit (See Paragraph 1. 12 (g) (2).)

Connect J4-11-P to C-3R.

Pull the remaining leads back through the slot and tape each lead individually and tie back. The remaining leads are for various options which may be desired.

Replace the phenolic covers on the C wiring field and reinstall the LESU in the cabinet and secure in place.

Note: The symbol * appearing on the "applicable" wiring diagrams has been replaced in this specification by the symbol +.

- (f) With the 35AY Unit do the following (referring to 6080WD):

- (1) Remove the four screws that hold the relay rack inside the cabinet. Slide the rack out to reveal the backside of the electrical service unit (LESU).

SPECIFICATION 50453S

- (2) Route the 312632 cable through the opening in the back of the cabinet and up through the bottom end of the LESU. Position the cable such that the tubing is in the middle of the wiring field board. A 121246 cable clamp is provided to secure the 312362 cable at the bottom end of the LESU using a 181243 screw with lockwasher and 7002 flat washer.
- (3) Mount the motor control relay (178306) to the inside of the LESU chassis using two 151630 screws, two 2191 lockwashers, two 7002 flat washers, and two 3598 nuts.
- (4) Connect the large white lead from the 312362 cable to terminal 2 of the motor control relay (MCR) 178306. Connect the large yellow lead to terminal 4. Connect the white-red lead to terminal 3. Connect the orange lead to terminal 1 of the MCR relay.
- (5) Mount the 180904 ground terminal to the LESU near the basic facilities package using a 151630 screw, 92260 star washer, 7002 flat washer, 2191 lockwasher, and a 3598 nut. Be sure the star washer is in contact with the LESU chassis.
- (6) Connect the black lead from the 312362 cable to this ground terminal.
- (7) Push the remaining leads through the slot to the front side of the C wiring field.

Move SMD-3-R from C-1H to C-1G. Move P-2-S+ from C-2H to C-3H.

Move B-4-W+ from C-4H to C-4G.

Connect MCR-2-W+ to C-2H. Connect MCR-4-Y+ to C-1H.

Connect J3-1-R to T4.

Connect J4-3-G to T3. Connect J3-13-BL to T4.

Connect J3-10-W-BL to C-1B. Connect C-1G to C-1H with 197054 strap.

Pull the remaining leads back through the slot and tape each lead connector individually and tie back under the LESU. These leads are not needed on the 35AY.

Replace the rack in the cabinet securing it with the four screws.

Note: The symbol * appearing on "applicable" wiring diagrams has been replaced in this specification by the symbol +.

TROUBLESHOOTING CHART

Note 1: The 312350 kit is to be replaced in the field and maintained in the repair center.

Note 2: The repair center must have equipment to simulate normal operation.

<u>SYMPTOM</u>	<u>PROBABLE CAUSE</u>
No dc voltage.	<ol style="list-style-type: none"> 1. CR10, 11, 12, or 13 open. 2. Loose connection on 198421 circuit board or P1 plug. 3. No ac input (115 v ac).
No output on transmitting circuits (circuit BA, CA, CD, CJ, CK, CL, CT, or CS)	<ol style="list-style-type: none"> 1. Wire broken in 198149 cable. 2. Loose connection on 198421 circuit board.
Selector magnet always marking (circuit BB)	<ol style="list-style-type: none"> 1. Q1 shorted collector-to-emitter. 2. CR1 or CR2 open. 3. Wire broken in 198419 cable. 4. Loose connection on 198421 circuit board.
Selector magnet always spacing (circuit BB)	<ol style="list-style-type: none"> 1. Q1 open base, emitter, or collector. 2. CR1, CR2, or CR3 shorted.
No output from receiving circuits (circuit CB, CC, CE, or CF)	<ol style="list-style-type: none"> 1. Q2, A3, or Q4 open or shorted. 2. CR5, CR7, or CR9 shorted. 3. Wire broken in 198419 cable. 4. Loose connection on 198421 circuit board.

SPECIFICATION 50453S

3. THEORY OF OPERATION (8021WD)

3.01 A cable is provided with the coupler for connection to the data set.

The cable terminates in a 25-pin connector which has been standardized for use with the data sets. Pin assignments for each circuit to the data set are shown below.

PIN ASSIGNMENTS FOR 145914 CONNECTOR
(Part of 198419 Cable Assembly)

<u>Pin No.</u>	<u>103A</u>	<u>103F</u>	<u>103E</u>
1	AA	AA	AA
2	BA	BA	BA
3	BB	BB	BB
4	R	CA	R
5	CB	CB	CB
6	CC	CC	CC
7	AB	AB	AB
8	CF	CF	CF
9	+20	+20	+20
10	-20	-20	-20
11	R	CK	R
12	R	CJ	R
13	U	U	U
14	NA	NA	NA
15	U	U	U
16	U	U	U
17	NA	NA	NA
18	R	R	R
19	U	U	U
20	CD	R	CD
21	U	U	U
22	CE	R	CE
23	R	R	R
24	NA	NA	NA
25	R	R	CL

U - Unassigned
R - Reserved (used on other data sets in the series)
NA - Not Applicable - circuit assigned by EIA but
not applicable in this series.

3.02 A 312362 cable is provided with the 312350 modification kit for connection between the terminal apparatus and the data set coupler. One end of the cable is terminated with "quick connect" push-on connectors. The other end of the cable is terminated in two 15-pin connectors. Pin assignments for each circuit to the terminal equipment are shown below.

PIN ASSIGNMENTS FOR 182540 CONNECTOR

<u>Connector - J3</u>	<u>Pin No.</u>	<u>Description</u>
	1	Transmitted data
	2	Protective ground
	3	Ring indicator
	4	Originate
	5	Machine selection
	6	Local
	7	+20 v dc
	8	
	9	<u>Transfer to Teletype</u>
	10	Data terminal ready
	11	
	12	<u>Signal generator</u>
	13	-20 v dc
	14	Request to send
	15	Send restraint

<u>Connector - J4</u>	<u>Pin No.</u>	<u>Description</u>
	1	117 v ac
	2	SMD 60 ma operation
	3	SMD 20 ma operation
	4	
	5	
	6	<u>Signal ground</u>
	7	117 v ac
	8	Data carrier detector
	9	Data set ready
	10	
	11	<u>Clear to send</u>
	12	Clear to send
	13	Clear to send
	14	Clear to send
	15	Clear to send

SPECIFICATION 50453S

3.03 The 312350 modification kit provides a cable for connection to the coupler. The cable will terminate in two 182539 connectors with 182644 terminals. These connectors terminate in J3 and J4 on 8021WD with pin assignments as shown on the wiring diagram. Leads for the following functions are provided.

- (a) Power Supply — The terminal apparatus must be supplied 115 v ac through the twist lock connector. This is connected to T1 which in turn provides two 20 v ac outputs with a center tap to ground. CR10, CR11, CR12, and CR13 comprise a rectifier bridge providing ± 20 v dc which is filtered by C1 and C2. R1 and R2 are current limiting resistors.
- (b) AA - Protective Ground — This conductor is electrically bonded to the frame of the terminal apparatus. It may be further connected to external grounds as required by applicable regulations and is available at J3-2.
- (c) BA - Transmitted Data — Signals on this circuit are generated by the terminal apparatus for transmission to remote data sets.
- (d) The signal generator(s) or regenerator(s) in the terminal apparatus is between J3-12 and -20 v (J3-13). When the signal generator contact is closed (mark), -20 volts is presented at J2-15. When the contact is open (space), +10 to +20 volts is presented at J2-15 through R3. Local copy (half-duplex) will be received through CR2 which is part of the input gate to circuit BB (received data).
- (e) Line break (normally closed contact) should be wired across J3-1 and J3-12. This provides a noninterfering break when receiving remote traffic on circuit BB (received data). If line break is not to be used, a strap must be provided across J3-1 and J3-12.
- (f) If local copy is not to be received when transmitting (full-duplex), J3-12-W-G should be placed on an empty terminal on the wiring field of the terminal set.
- (g) The signal generator in the terminal apparatus is required to break 40 v dc at approximately 15 ma in this circuit.

3.04 BB - Received Data — Signals on this circuit are generated by the data set in response to data signal received from remote data sets.

- (a) Data signals received by the data set are presented to CR1 as ± 5 to ± 25 volt signals. Signals generated by the local signal generator are similarly presented to CR2. CR1 and CR2 serve as an input gate to Q1. Negative signals (mark) at CR1 or CR2 are blocked and the base of Q1 is held negative by -20 v through R13 which allows the transistor to conduct.

This provides ground at the junction of the collector of Q1, CR14, R15, and R20; the latter two of which are current limiting resistors for receiving selector magnet drivers which may be operated at 20 or 60 ma when connected to J4-3 or J4-2, respectively. The negative input to the selector magnet driver should be connected to -20 v (J3-13). CR14 limits the collector voltage. Inductive devices, such as relay coils, may also be operated from this circuit at -20 volts. Positive signals (space) at CR1 or CR2 are conducted through R14 and CR3 to ground holding the base of Q1 positive which turns the transistor off.

- 3.05 CB - Clear to Send — Signals on this circuit are generated by the data set to indicate that the data set is ready to transmit data when in the on condition.
- (a) Signals of +3 to +25 volts are presented to R16 by the data set. Negative signals are conducted through CR5 to ground holding the base of Q2 negative and turning the transistor off. Positive signals are conducted through R16 turning Q2 on as well as K1 relay. CR4 limits the collector voltage. The contacts of the clear to send relay (K1) include one make and one transfer contact presented to the terminal apparatus at J4-11, J4-12, J4-13, J4-14, and J4-15. These contacts may be used to turn on a tape reader, control relay, signal lamp, or any other feature required by the terminal apparatus.
- (b) The nominal pickup and release time of the clear to send relay is approximately 7 and 37 milliseconds, respectively.
- (c) The load on the clear to send relay contact should not exceed 3 amps at 115 v ac, 60 Hz, resistive or 3 amps at 30 v dc, resistive. Adequate spark suppression should be provided.
- 3.06 CC - Data Set Ready — Signals on this circuit are generated by the data set to indicate that it is ready to operate (on condition). The off condition indicates any abnormal or test condition which impairs normal operation.
- (a) Signals of +3 to +25 volts are presented to R17 by the data set. Negative signals are conducted through CR7 to ground holding the base of Q3 negative, turning the transistor off, and opening the collector circuit. Positive signals are conducted through R17 turning Q3 on and making the collector ground. CR6 limits the collector voltage.
- (b) When the data set ready signal is received; Q3 conducts, pulls up the motor control relay which turns on the terminal set.

SPECIFICATION 50453S

3.07 CD - Data Terminal Ready — Signals on this circuit are generated by the terminal apparatus to control switching of the data set to a communications channel. The on condition causes the data set to be connected to a communications channel. The off condition removes the data set from a communications channel for such reasons as terminating a call, freeing the line for alternate use, or permitting the use of the terminal apparatus for an alternate function.

- (a) A contact closure between J3-10 and -20 v (J3-13 presents -15 volts at J2-9 through R9) indicating an off condition. If the contact is open, +10 to +20 volts appears at J2-9 through R 8 indicating an on condition.
- (b) The above contact in the terminal apparatus will be required to break 40 v dc at approximately 13 ma.
- (c) A low paper switch may be used in this circuit to take the terminal set off line when the paper supply is low.

3.08 The following functions are not provided but may be added options. The 312362 cable contains three extra leads to be used when an option is desired.

- (a) AB - Signal Ground — This conductor establishes the common ground potential for all interchange circuits except circuit AA (protective ground). It may be connected to circuit AA or the frame, as required by applicable regulations, and is available at J4-6.
- (b) CA - Request to Send — Signals on this circuit are generated by the terminal apparatus to condition the data set to transmit. The on condition must be maintained whenever traffic is ready to be transmitted or is being transmitted.
- (c) A contact closure between +20 (J3-7) and J3-14 presents +15 volts at J2-8 through R5 indicating an on condition. If the contact is open, -10 to -20 volts appear at J2-8 through R4 indicating an off condition.
- (d) The request to send contact in the terminal apparatus will break 40 v dc at approximately 13 ma.
- (e) For receive-only operation, circuit CA should be held off at all times.
- (f) For transmit only operation, circuit CA should be held on at all times.

- (g) CE - Ring Indicator — Signals on this circuit are generated by the data set to indicate that ringing current is being received from a remote station. The on condition indicates that a ringing signal is being received with the off condition maintained at all other times.
- (h) Signal on this circuit is presented to the terminal apparatus on J3-3 directly from the data set as a bi-polar signal. Terminal apparatus using this circuit must conform to EIA requirements for circuit conformance.
- (i) CF - Data Carrier Detector — Signals on this circuit are generated by the data set to provide an indication that the data carrier is being received when in the on condition. The off condition indicates that the data carrier is lost.
- (j) Signals of +3 to +25 volts are presented to R18 by the data set. Negative signals are conducted through CR9 to ground holding the base of Q4 negative, turning the transistor off, and opening the collector circuit. Positive signals are conducted through R18, turning Q4 on, and making the collector ground. CR8 limits the collector voltage.
- (k) Control devices, such as relays, may be connected between J4-8 and +20 v (J3-7). The operating current of these devices should not exceed 50 ma.
- (l) CJ - Local — Signals on this circuit are generated by the terminal apparatus to remove the data set from the communications channel so that the terminal apparatus may function on a local circuit. The on condition causes the data set to be in the LOCAL mode.
- (m) A contact closure in the terminal apparatus between J3-6 and +20 v (J3-7) presents +20 volts at J2-11 and -10 to -20 volts through R7 when the contact is open.
- (n) The above contact must break 40 v dc at approximately 15 ma.
- (o) CK - Originate — Signals on this circuit are generated by the terminal apparatus to determine if the data set functions as an originating or answering station. The on condition causes the data set to be in the answer mode and the off condition causes the data set to be in the ORIGINATE mode.
- (p) A contact closure in the terminal apparatus between J3-4 and +20 v (J3-13) presents -20 volts at J2-12 and +10 to +20 volts through R6 when the contact is open.

SPECIFICATION 50453S

- (q) The above contact must break 40 v dc at approximately 15 ma.
- (r) CL - Send Restraint — Signals on this circuit are generated by the terminal apparatus to cause the data set to send a restraint signal when the on condition is maintained. The off condition causes transmission to be resumed.
- (s) A contact closure in the terminal apparatus between J3-15 and +20 (J3-7) presents +20 volts at J2-5 and -10 to -20 volts through R12 when the contact is open.
- (t) The above contact is required to break 40 v dc at approximately 15 ma.

3.09 The above circuits may be ignored by the terminal apparatus if control of the circuit is not required or if it is not offered by a specific data set in the aforementioned series. If the control is to be fixed in one state or another, strap options may be specified in the terminal apparatus.

3.10 The delay time introduced by the coupler in switching the above circuits may be considered negligible with the exception of circuit CB (clear to send).

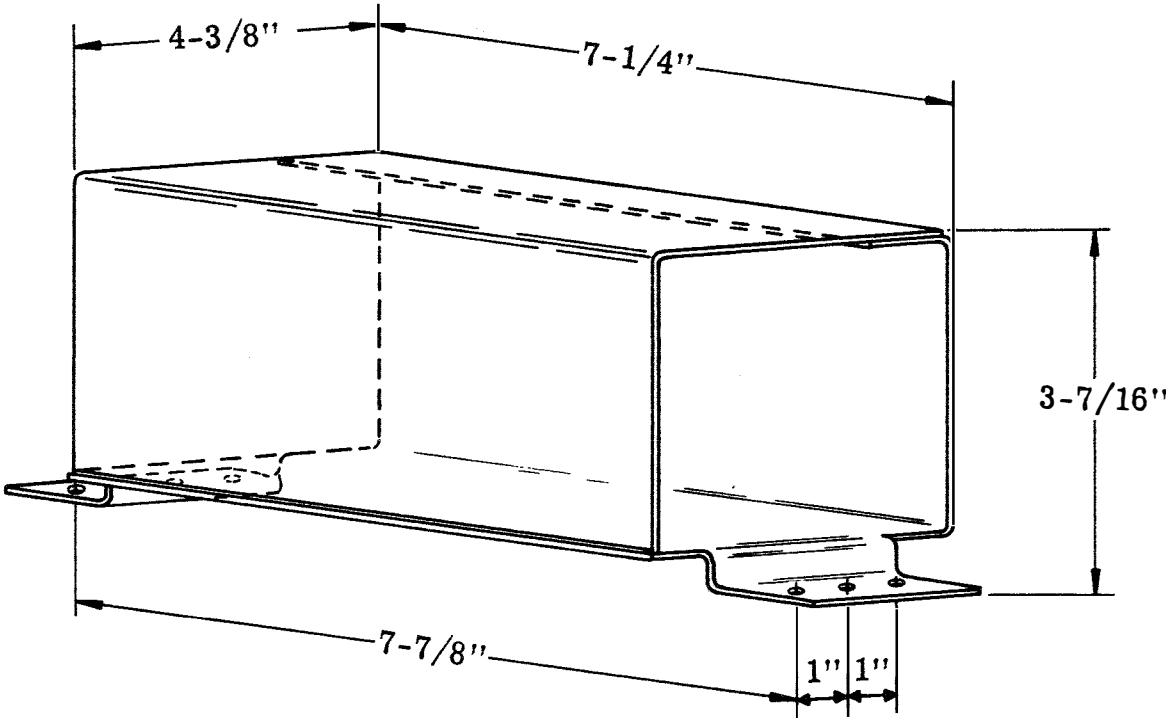

FIGURE 1

