

INSTRUCTIONS FOR INSTALLING THE 195104 MODIFICATION
KIT TO PROVIDE MOUNTING SHELF FOR THE SINGLE REEL TAPE
WINDER ON UPPER LEFT SIDE OF MODEL 28 ASR SET

1. GENERAL

a. The 195104 Modification Kit provides a mounting shelf and hardware for mounting a TW200, TW203 or TW204 Type Motor Driven Tape Winder on the Model 28 Automatic Send-Receive Set. The shelf allows winding of tape from the keyboard punch or transmitter.

b. The 195104 Modification Kit when used with the 195107 Modification Kit (provides a mounting shelf for a single reel tape winder on the lower left side of the ASR Set) allows simultaneous tape winding from the keyboard punch and transmitter.

c. The 195104 Modification Kit consists of:

| | | | | | |
|---|------|--------------|---|--------|-------------------|
| 2 | 2191 | Washer, Lock | 2 | 108355 | Nut |
| 2 | 2449 | Washer, Lock | 2 | 152848 | Screw |
| 2 | 2846 | Washer, Flat | 2 | 194575 | Post, Locating |
| 2 | 3606 | Nut | 1 | 195397 | Bracket, Mounting |
| 2 | 7002 | Washer, Flat | 1 | 199929 | Guide, Tape |

d. For parts ordering information and parts referred to see Teletype Parts Bulletin 1169B.

2. INSTALLATION

a. The 195104 Modification Kit contains a mounting bracket which is mounted to the Model 28 ASR Set as shown in Figures 1 and 2. Locating posts must be secured to the mounting bracket over which is placed the tape winder.

b. A 199929 Tape Guide is provided for mounting on the tape winder as shown in Figure 3. Position the guide and tighten the screw so the tape runs freely over the guide and into the winder.

c. With tape coming from the reader, over the tape arm and into the winder, position the 195397 mounting bracket within its slots so the tape travels squarely out of the reading head. Tighten bracket mounting screws.

*

*

*

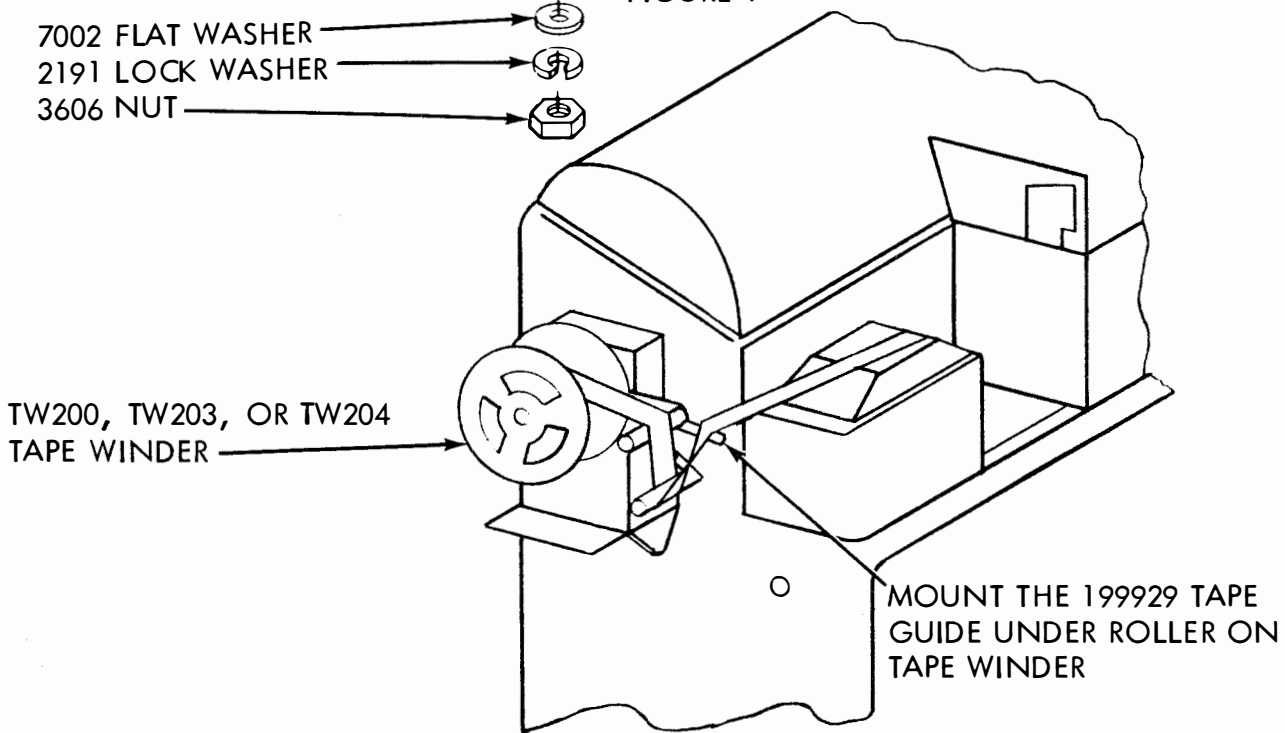
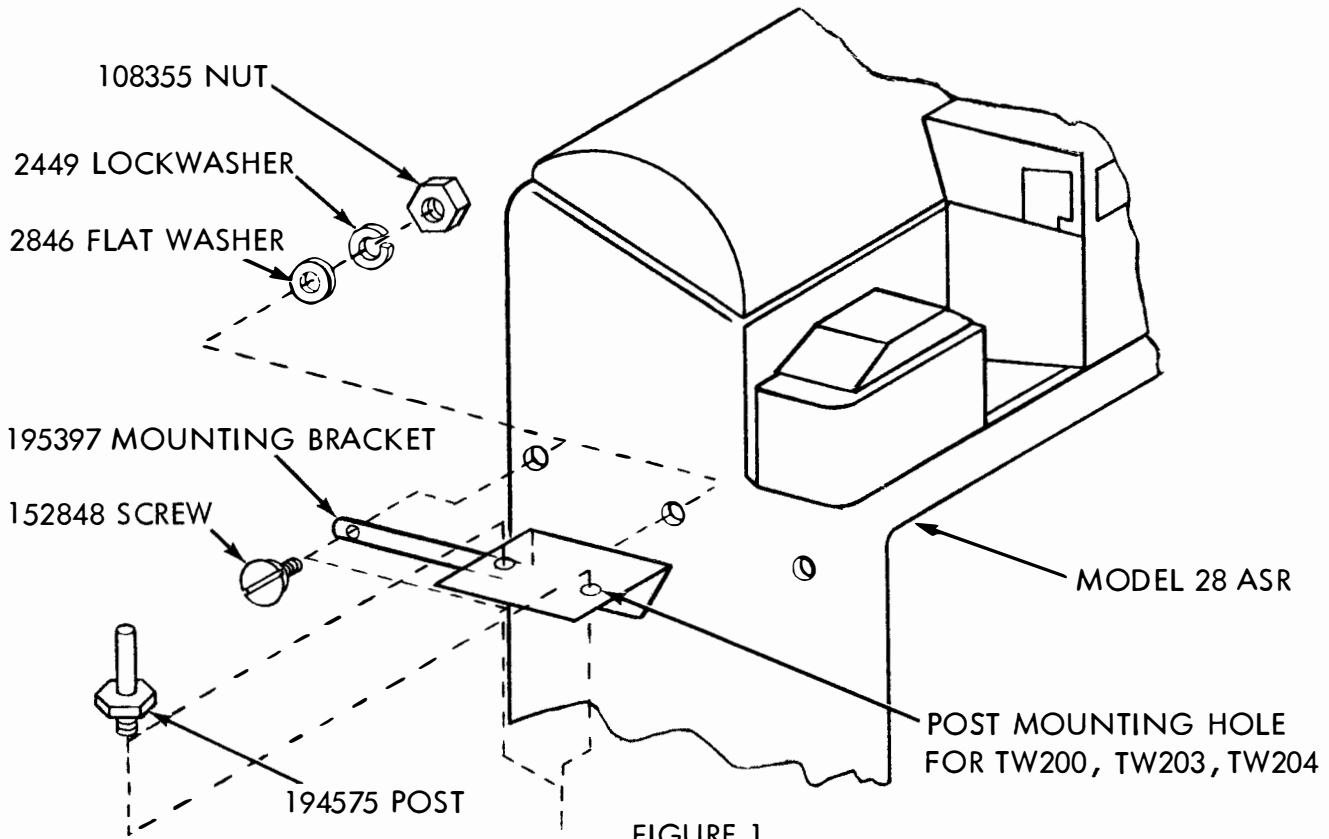

ASSEMBLY PROCEDURE FOR MOUNTING THE 199929
TAPE GUIDE ON TW200, TW203 AND TW204 TAPE WINDERS

TW200 TAPE WINDER

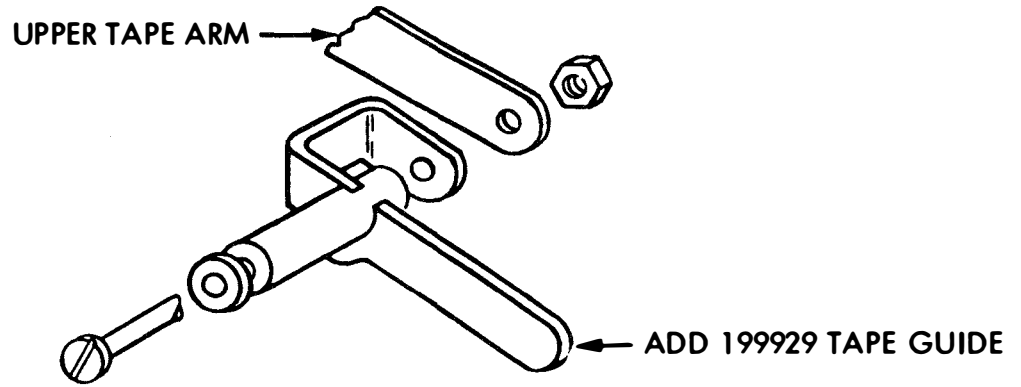

TW203

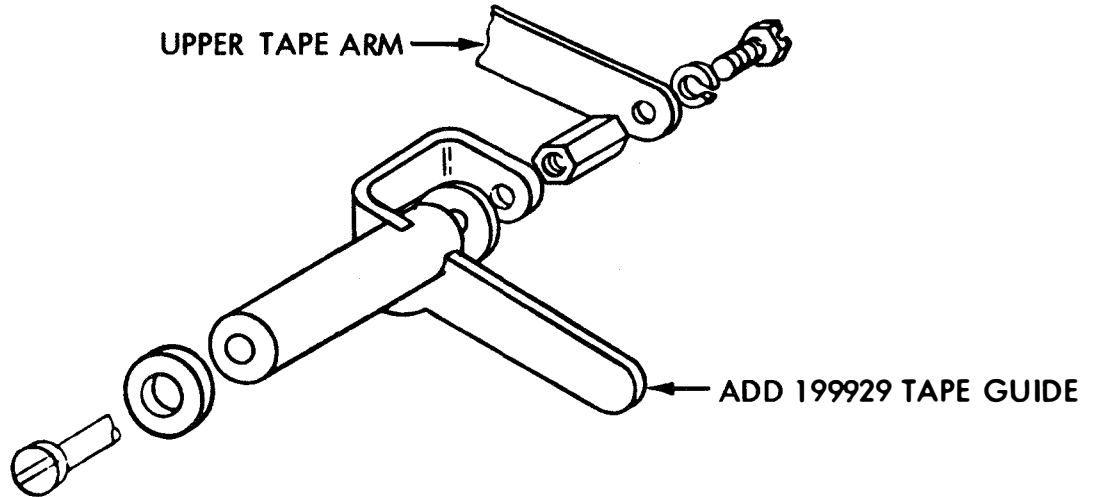

TW204

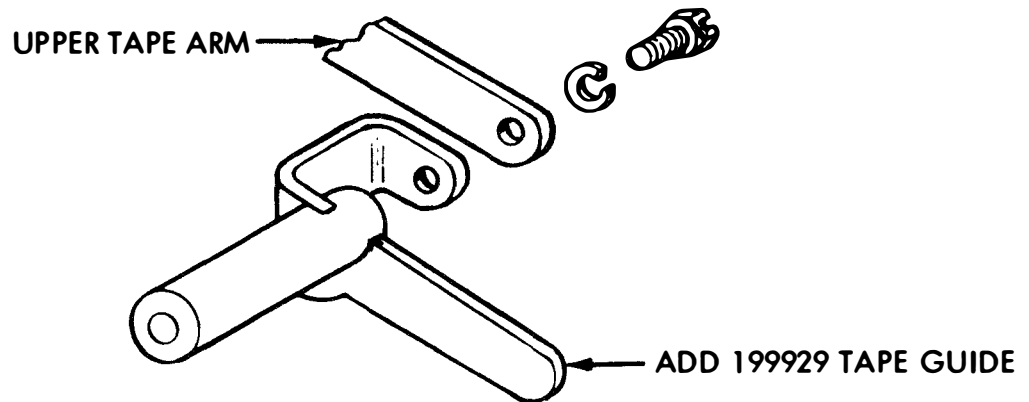

FIGURE 3