

**INSTRUCTIONS FOR INSTALLING THE 164998 MODIFICATION KIT TO EQUIP A MODEL 28 KEYBOARD (LK6 AND UP) FOR BLINDING ASSOCIATED APPARATUS AND THE 162224 MODIFICATION KIT TO EQUIP A MODEL 28 KEYBOARD (LK6 AND UP) WITH AN ELECTRICAL SEND-RECEIVE-BREAK MECHANISM.**

The chart below pertains to Bell System only

Model 28 Unit (Teletype Name)	Teletype Code	Bell System Reference	Bell Code
Keyboard	LK16 and up	Base-Send-Rec.	28D and up
For adjustments, lubrication and wiring refer to standardized information.			

**1. GENERAL**

**a. 164998 MODIFICATION KIT**

(1) The 164998 Modification Kit equips a Model 28 Keyboard (LK6 and up) with a pulsing contact for blinding an associated piece of apparatus or the signal generator on the keyboard. Basically the kit consists of a normally closed contact assembly that is actuated by a cam follower which in turn is cam driven through the main shaft of the signal generator mechanism.

(2) The 164998 Modification Kit consists of:

2	2191	Washer, Lock	1	162878	Contact Assembly
2	7002	Washer, Flat	1	162885	Cam, Segment
1	121243	Clamp, Cable	2	162886	Screw
2	151631	Screw	1	172962	Cable
4	155753	Sleeve, Insulating			

**b. 162224 MODIFICATION KIT**

(1) The 162224 Modification Kit provides a Model 28 Keyboard (LK6 and up) with an electrical send-receive-break mechanism. Basically the kit consists of a contact assembly and a modified locking bar. With this feature the keyboard is not locked mechanically.

\*(2) In modifying the keyboard, the "KBD LOCK" (keyboard lock) and "KBD UNLK" (keyboard unlock) keytops are replaced with "REC" (receive) and "SEND" keytops respectively. When the "SEND" key is depressed the locking bar is moved to the left. The motion of the locking bar is transferred through the actuating lever to the contact assembly. This motion opens the normally closed contact which is used to shunt the signal generator, and closes the normally open contacts

\* General Revision

© 1959 and 1961 by Teletype Corporation  
 All rights reserved.

Printed in U.S.A.

which control the transmitter distributor unit. When the "REC" key is depressed the locking bar is moved to the right. This motion closes the signal generator shunt circuit, and opens the transmitter distributor unit control circuits.

(3) The shunting of the signal generator and the opening of the transmitter distributor control circuit can also be accomplished through the page printer on receipt of a predetermined signal such as "line break."

(4) The 162224 Modification Kit consists of:

1	2191	Washer, Lock	1	158010	Bar, Locking
1	3598	Nut	1	158226	Bracket W/Bushing
2	7002	Washer, Flat	1	158228	Lever W/Stud
1	119648	Ring, Retaining	1	158230	Bracket
1	121244	Clamp, Cable	1	158231	Contact Assembly
2	151631	Screw	1	158275	Plate, Clamp
1	151632	Screw	2	158277	Screw
10	155753	Sleeve, Insulating	1	158299	Cover, Contact
1	155843	Keytop - SEND	1	162335	Cable
1	155844	Keytop - REC.			

c. For parts referred to, other than those included in the modification kits, refer to Teletype Model 28 Page Printer Set Parts Bulletin 1149B.

## 2. INSTALLATION

a. 164998 MODIFICATION KIT(Figures 1,2, and 3)

\* (1) Remove and discard the two screws which secure the cam sleeve assembly to the clutch disk; retain the two 110743 Lock Washers. Install the 162885 Cam Segment using the two 162886 Screws and 110743 Lock Washers (retained) as shown in Figure 1.

### NOTE

Check the following two requirements pertaining to the 162878 Contact Assembly. A third requirement (Paragraph (5) should be checked after the soldering operation (Paragraph (4)). (This contact assembly is shipped factory adjusted. However, some of the adjustments may have been disturbed in shipment.)

(2) Both contact surfaces should be reasonably parallel to each other. To adjust, bend the long contact spring to meet this requirement.

\* (3) With the cam follower arm resting on the stop screw, there should be .010" to .025" clearance between the upper extension of the cam follower arm and the contact spring insulator. To adjust, loosen the lock nut and position the stop screw; tighten the lock nut. See Figure 1.

(4) Place a 155753 Insulating Sleeve on each lead at one end of the 172962 Cable. Solder the white-yellow lead to the upper terminal of the 162878 Contact Assembly and the white-red lead to the lower terminal; slip the insulating sleeves over the soldered connections.

\* (5) Remove the contact guard by removing its two mounting screws. Hook an 8 oz. scale to the long contact spring as shown in Figure 1, and pull upward. It should require 3-1/2 to 4-1/2 ozs. to just separate the contacts. To adjust, bend the long contact spring. Recheck the "parallel" requirement in paragraph (2) after meeting this requirement. Replace the contact guard.

(6) Mount the 162878 Contact Assembly on the signal generator using the two 151631 Screws, 2191 Lock Washers and 7002 Washers. See Figure 1.

#### NOTE

Perform the following three pulsing contact adjustments in sequence.

(7) With equal clearance between the contact springs and the contact guard, there should be at least .010" clearance between the contact guard and the rocker bail assembly. To adjust, loosen (friction tight) the contact guard and contact pile-up mounting screws and position the guard and pile-up to meet the requirements (see Figure 2). Tighten the screws. Check to see that the contact points meet squarely.

\* (8) Rotate the main shaft until the lower extension of the cam follower arm (see Figure 1) rests on the high part of the cam segment. The clutch should now be in its latched position. There should be a .015" to .025" gap between the contact points. To adjust, loosen the two contact bracket mounting screws, leaving the lower screw friction tight. Position the contact bracket by means of the slotted upper mounting hole to meet the requirement; tighten the screws.

\* (9) There should be at least .015" clearance between the lower extension edge of the cam follower arm and the inside surface of the clutch disk. To adjust, loosen (friction tight) the two contact pile-up mounting screws and position the cam follower hinge; tighten the screws (see Figure 2). Recheck Paragraphs (7) and (8).

#### NOTE

When checking this adjustment, rotate the main shaft several times and check the entire cycle. Make certain that the lower extension of the cam follower arm does not come in contact with the adjusting disk clamp screws; see Figure 1.

(10) Route and clamp the 172962 Cable and solder the leads to the keyboard connector as shown in Figure 3; place a 155753 Insulating Sleeve on each of the leads and solder the white-yellow lead to terminal 9 and the white-red lead to terminal 10; slip the insulating sleeves over the soldered connections. Substitute the 121243 Cable Clamp for the 121242 Signal Generator Cable Clamp and secure both cables using the 121243 Clamp and the existing mounting parts. Tie the 172962 Cable to the signal generator cable as necessary.

(11) The following requirements should be met after the 164998 Modification Kit is installed:

(a) For installations where a distortion test set is available - Set up the "LETTERS" code combination and orient the scale of the test set with the signal. Introduce the pulsing contact into the circuit (continue transmitting "LETTERS" code combination) and adjust the contact so as to close just before the beginning of the start pulse and remain closed until just after the end of the fifth pulse. Slight breaks (up to 2 divisions) are permissible at each end of the blinding pulse, however none are allowed in between the general blinding scale range.

(b) For installation where a distortion test set is not available (results may not be as good as when a test set is employed) - With an indicator lamp connected across the pulsing contact, rotate the main shaft until the clutch becomes disengaged (latched up). Set up the "LETTERS" code combination and rotate the main shaft slowly. The lamp should light up the moment the third 154040 Transfer Lever from the rear (start pulse) begins to bear down on the 154010 Transfer Bail. The lamp should remain lit until just before the sixth transfer lever from the rear (fifth pulse) latches up on the transfer bail. Refine the adjustments, if necessary, and check out the blinding cycle with the associated unit in the circuit while operating under motor power.

(12) Apply a light film of KS7471 Grease on the contact insulator engaging surface of the cam follower extension, and two drops of KS7470 Oil to the camming surface of the cam segment. Avoid getting lubricant on the contact points.

b. 162224 MODIFICATION KIT (Figures 4 and 5)

(1) Remove the typing unit and the signal generator from the keyboard in accordance with instructions covered in Teletype Model 28 Printer Adjustment Bulletin 217B.

(2) Remove and retain the six code bar springs (one 49420 Spring and five 2415 Springs). Remove and discard the 3870 Locking Bar spring.

(3) Remove and retain the 110437 Universal Bail Spring. Remove and discard the 154013 Code Bar Spring Bracket and its two 151630 Mounting Screws; retain the two 2191 Lock Washers. Remove and retain the 154008 Code Bar Guide.

(4) Substitute the 158010 Locking Bar for the 154052 Locking Bar.

(5) Install the 158228 Lever W/Stud on the 158226 Bracket W/Bushing so that the lever portion is on the inside of the bracket. Secure the lever using the 119648 Retaining Ring. See Figure 4.

\* (6) Route and clamp the 162335 Cable and solder the leads to the 158231 Contact Assembly and the connector as shown in Figure 5; place a 155753 Insulating Sleeve on each of the ten loose leads before soldering; slip the insulating sleeves over the connections after soldering. Tie the 162335 Cable as necessary.

NOTE

The leads from the three normally open contacts may be connected to the spare keyboard connector terminals depending on the electrical service unit being used and how the customer desires to employ the contacts.

(7) Replace the 154008 Code Bar Guide and install the 158230 Bracket and the 158226 Bracket as follows:

(a) The formed portion of the 158230 Bracket should be toward the rear.

\* (b) Fit the formed portion of the 158228 Lever into the slot in the 158010 Locking Bar. Install the 158230 Bracket, 154008 Code Bar Guide and 158226 Bracket on the 154068 Code Lever Guide Bracket using the two 151631 Screws and 2191 Lock Washers (retained) in Paragraph (3). See Figure 4.

(8) Install the 158231 Contact Assembly (insulating button on the long contact spring should be against the 158228 Lever) and 158299 Contact Cover on the 158230 Bracket using the two 158277 Screws and the 158275 Clamp Plate. See Figure 4.

(9) Replace the six code bar springs (one 49420 Spring and five 2415 Springs) and 70466 Universal Bail Spring removed previously.

(10) Substitute the 155844 "REC" Keytop for the "KBD LOCK" keytop, and the 155843 "SEND" Keytop for "KBD UNLK" keytop.

(11) Remount the signal generator and the typing unit on the keyboard by reversing the removal procedures.

(12) Adjustments - Locking Bar Contact Assembly.

(a) The normally open contacts should have a gap of .008" to .012" with the "REC" key depressed. The normally closed contacts should have a gap of .008" to .012" with the "SEND" key depressed and released. All contacts should close with a small amount of overtravel. To adjust, bend the contact springs to meet the requirements using a contact bending tool and taking care not to misshape the contact springs.

(b) With the locking bar latched and with a 32 oz. scale hooked to the insulator of the long contact spring as shown in Figure 4, it should require 10 to 15 ozs. to start movement. To adjust, bend the contact springs to meet the requirement. Recheck Paragraph (a) above.

(13) Lubrication (use KS7470 Oil and KS7471 Grease)

(a) 158010 Locking Bar - Light film of grease on all sliding surfaces.

(b) 158228 Lever - Light film of grease at points of contact with the locking bar and the insulator on the long contact spring. One drop of oil at the lever pivot point. Avoid getting lubricant on the contact points.

\*

\*

\*

FIGURE 1. PERTAINS TO 164998 MODIFICATION KIT

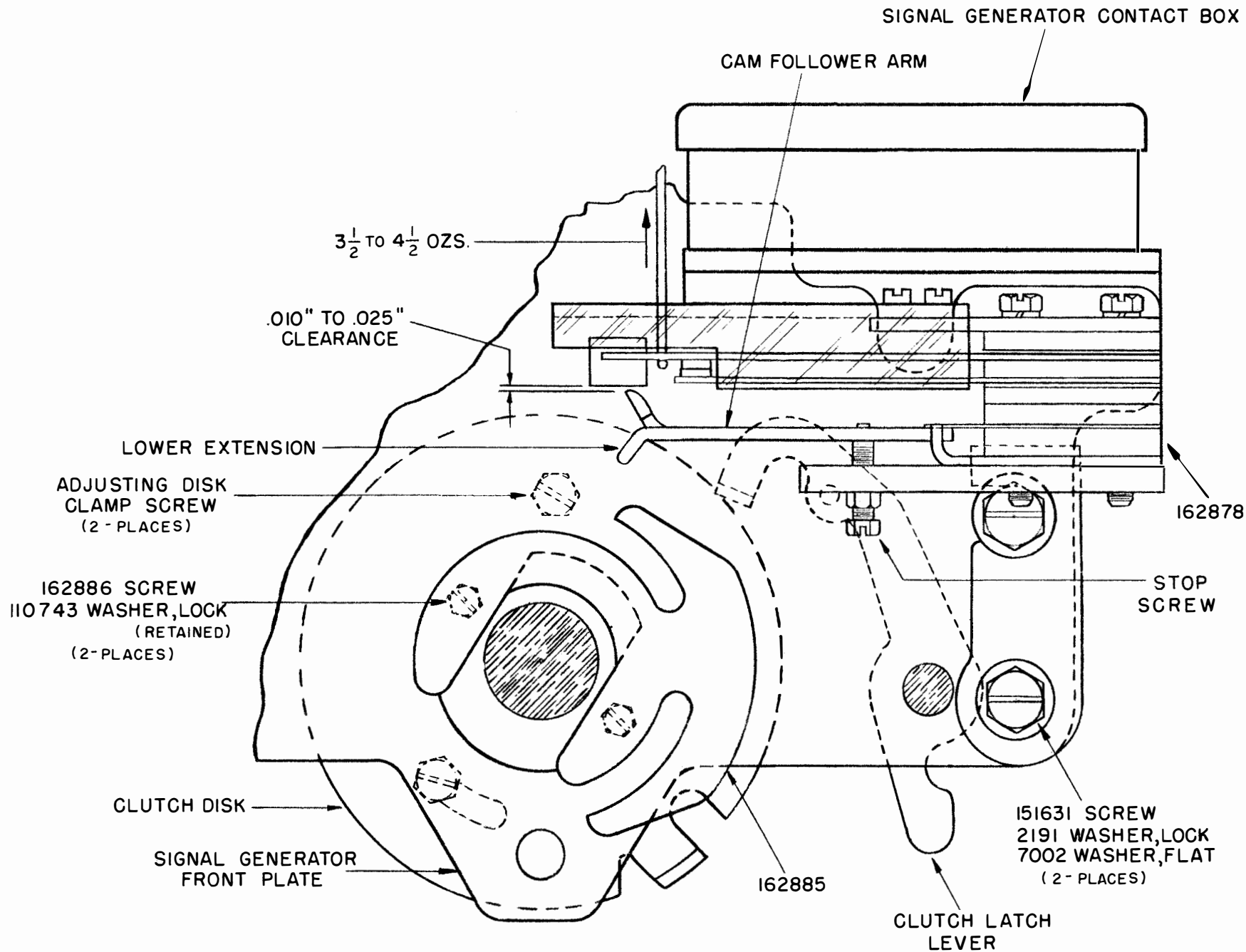

500305

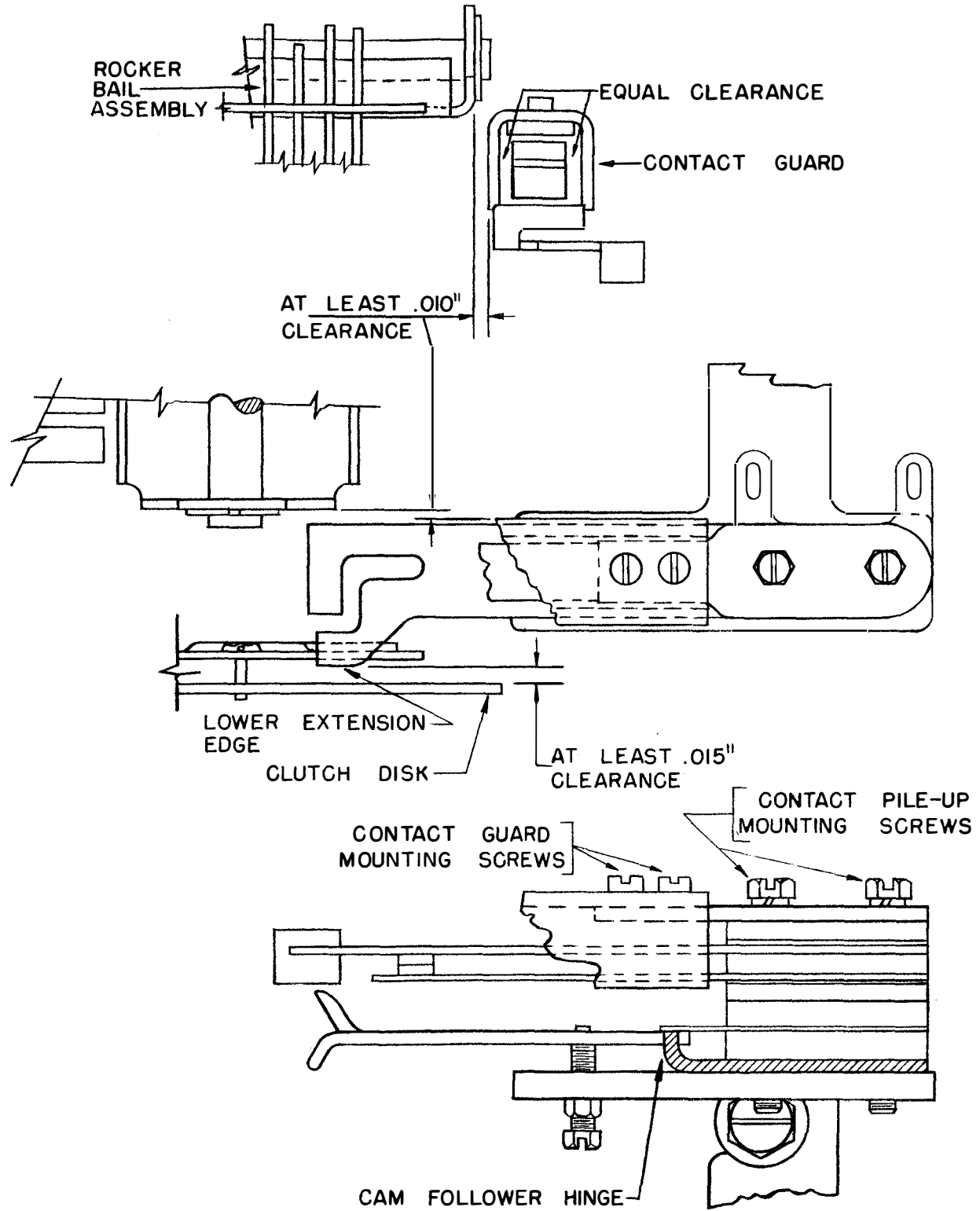

FIGURE 2. PERTAINS TO 164998 MODIFICATION KIT



50030S

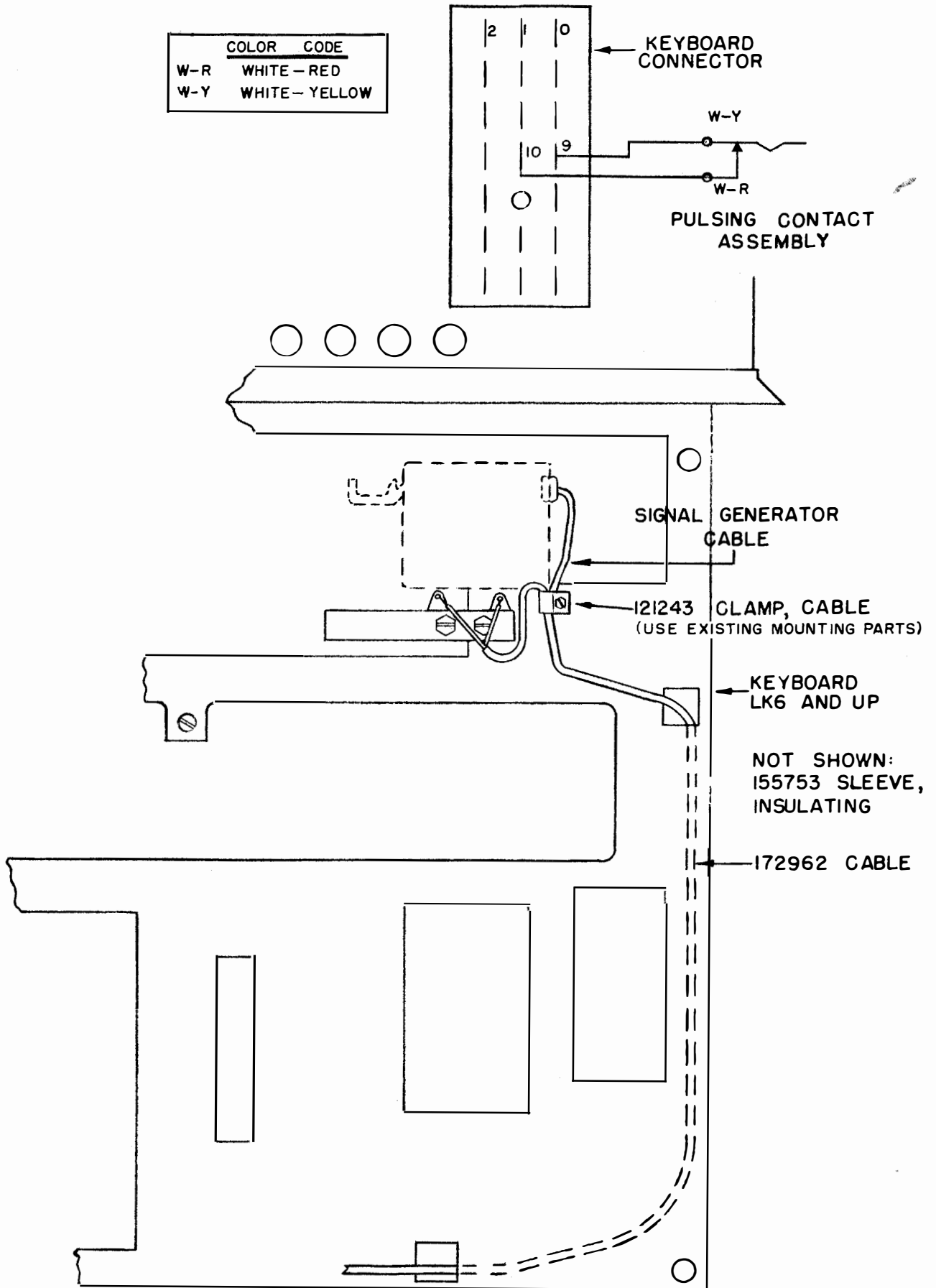
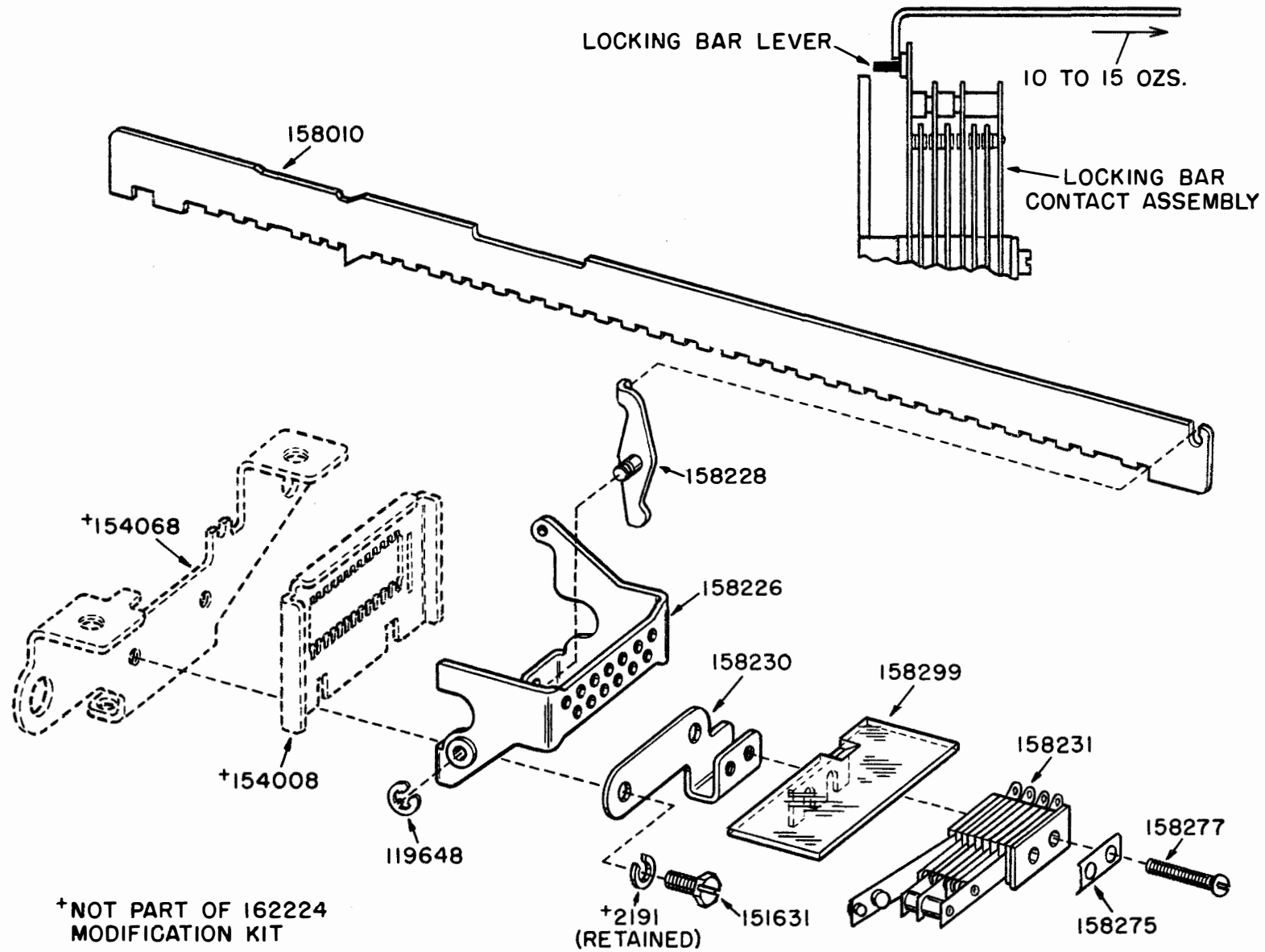

FIGURE 3. PERTAINS TO 164998 MODIFICATION KIT

FIGURE 4. PERTAINS TO 162224 MODIFICATION KIT



500305

NOTE: REMAINDER OF LEADS MAY BE WIRED INTO CONNECTOR AT THE DISCRETION OF THE CUSTOMER

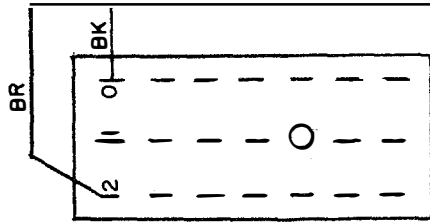

KEYBOARD CONNECTOR

COLOR CODE	
O	ORANGE
W	WHITE
BK	BLACK
BL	BLUE
BR	BROWN
W-G	WHITE-GREEN
W-O	WHITE-ORANGE
W-R	WHITE-RED

NOT SHOWN:  
155753 SLEEVE,  
INSULATING

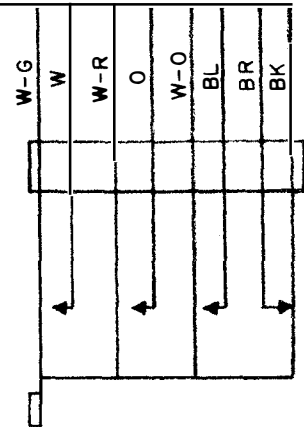

LOCKING BAR CONTACT ASSEMBLY

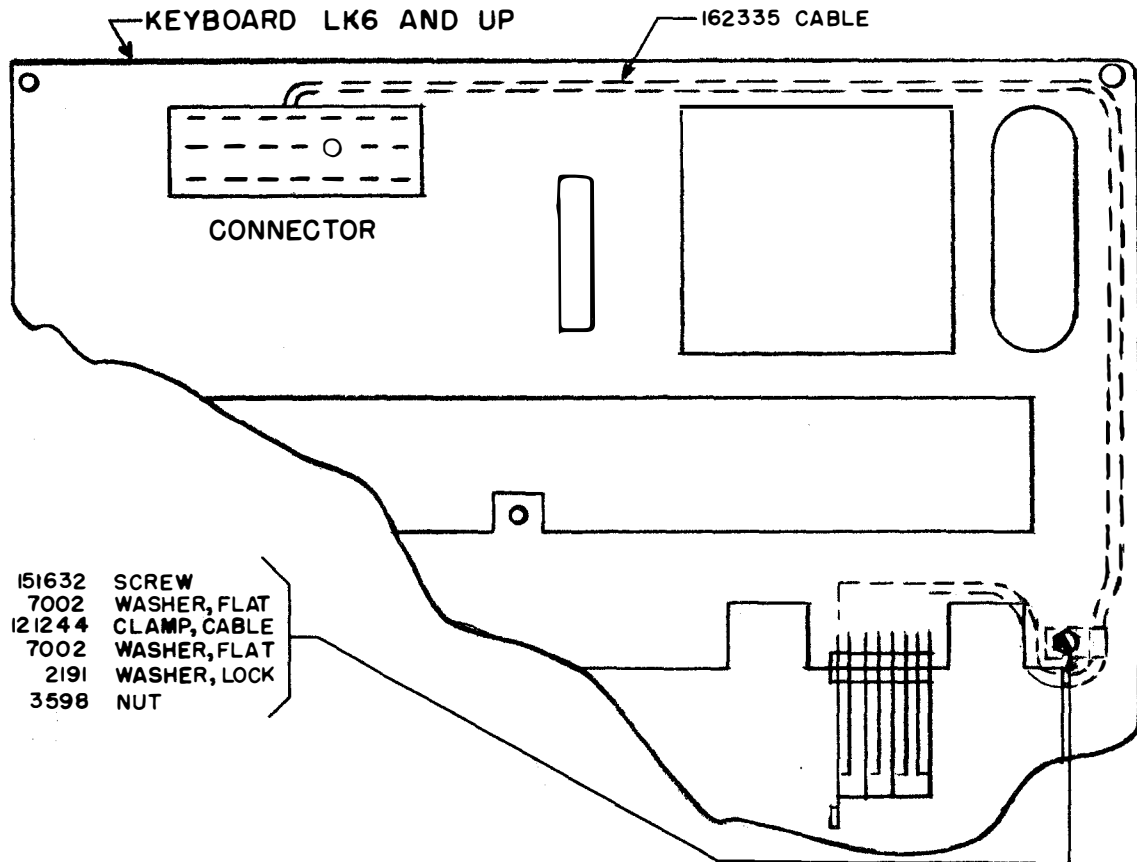

FIGURE 5. PERTAINS TO 162224 MODIFICATION KIT