

BELL SYSTEM PRACTICES
Teletypewriter and Data Stations

SECTION P34.530
Issue 2, November, 1963
AT&T Co Standard

28 PERFORATOR-TRANSMITTER-BASE LUBRICATION

CONTENTS	Paragraph
1. GENERAL	1.01-1.04
2. LUBRICATION	2.01-2.93
A. Keyboard	2.01-2.44
B. Typing and Nontyping Perforators	2.45-2.90
C. Typing and Nontyping Reperforators	2.91-2.93
3. ASSOCIATED BELL SYSTEM PRACTICE	3.01

1. GENERAL

1.01 This section contains the specific lubrication procedures for the 28 perforator-transmitter-base. The material herein, together with the section containing the general lubrication instructions on teletypewriter apparatus, provides the complete lubrication information for maintenance.

1.02 This section is reissued to revise various lubrication procedures in accordance with changes authorized for this apparatus by P98 series Bell System Practices listed at the end of this section and to include other authorized revisions and additions to bring the section generally up to date. Since this is a general revision, the marginal arrows ordinarily used to indicate changes have been omitted.

1.03 The lubrication symbols used herein are the same as those in the general section. However, the symbol **O** is used in this practice to mean only one drop of oil. Symbols, such as **O2**, **O3**, **O4**, **O5**, and **O20**, are used to indicate respectively two, three, four, five, or twenty drops of oil.

1.04 The apparatus should be lubricated before being placed in service as specified in the section covering the preparation of teletypewriter apparatus for installation. After a few weeks in service, it should be relubricated to make certain that all specified points have lubricant. Thereafter, because of varying conditions at each station, the apparatus should be lubricated as often as specified by local instructions. The following lubrication interval is suggested as a guide for use under normal operating conditions.

<u>Operating Speed</u> <u>(Words per Minute)</u>	<u>Lubrication Interval</u> <u>(Whichever Occurs First)</u>
60	3000 hours or 1 year
75	2400 hours or 9 months
100	1500 hours or 6 months

2. LUBRICATION

A. Keyboard

2.01 Keyboard Mechanism — Bottom View

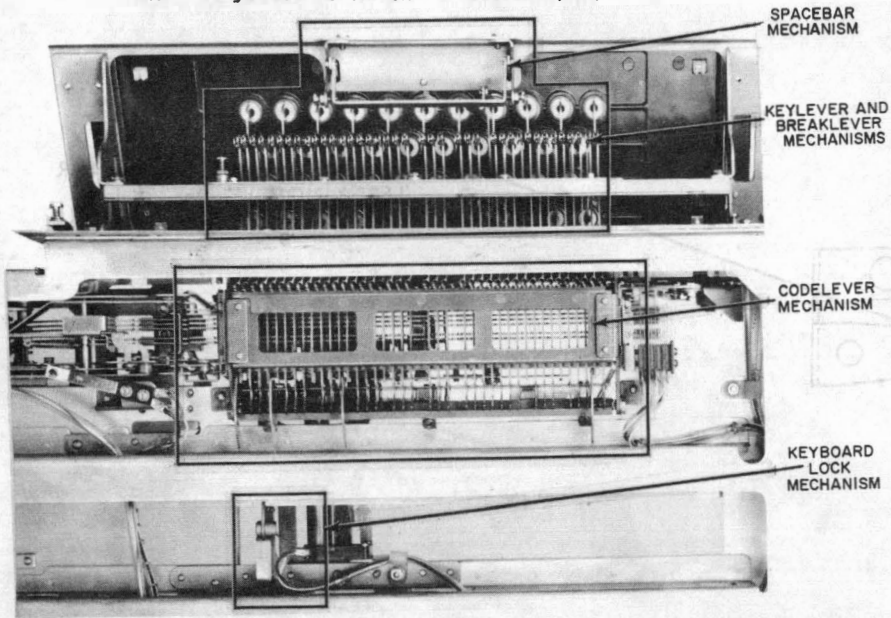

28 PERFORATOR-
TRANSMITTER-
BASE
LUBRI-
CATION

P34.530

Page 3

2.02 Spacebar Mechanism — See 2.01

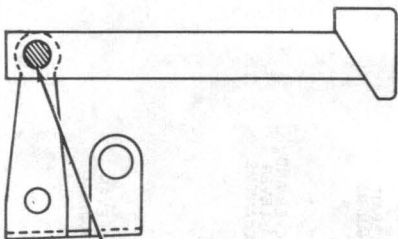

0 BEARING SURFACE SPACE BAR
(LEFT & RIGHT)

2.03 Keylever Mechanism — See 2.01

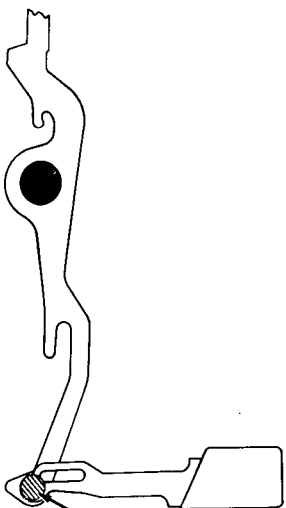

0
ENGAGING SUR-
FACE (36 LEVERS)

KEYTOP LEVERS

28 PERFORATOR-
TRANSMITTER-

P34.530

BASE
LUBRI-
CATION

2.04 Breaklever Mechanism — See 2.01

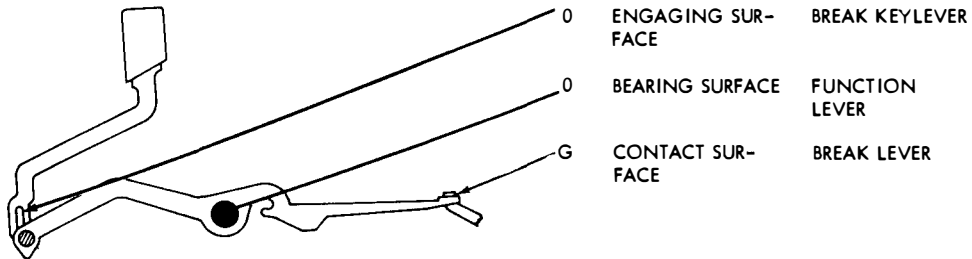

2.05 Codelever Mechanism — See 2.01

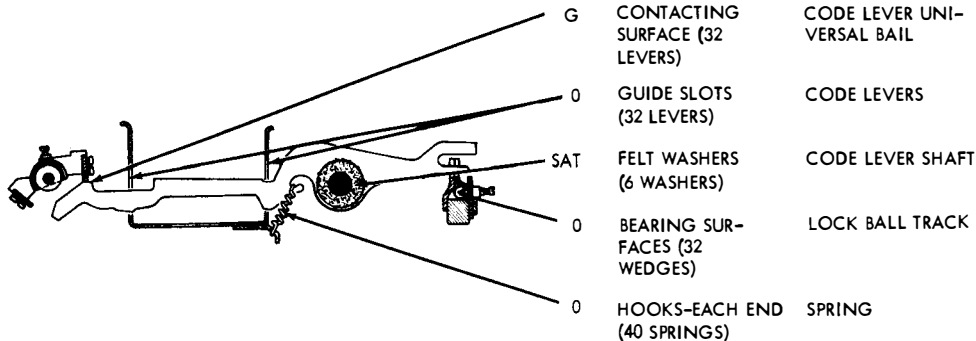

28 PERFORATOR-
TRANSMITTER-
BASE
LUBRI-
CATION

P34.530

Page 7

2.06 Keyboard Lock Mechanism — See 2.01

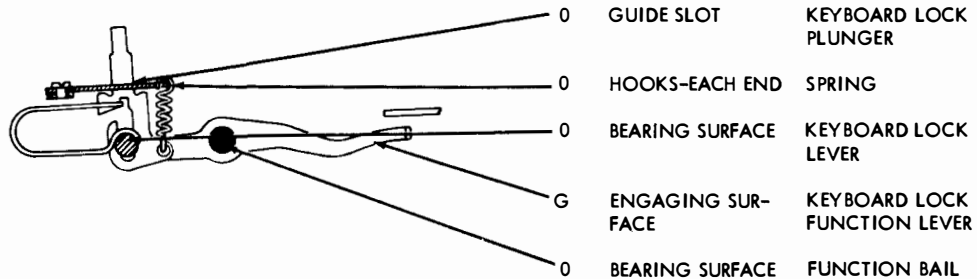

2.07 Keyboard Mechanism — Bottom View

DETENT LEVER
MECHANISM

SELECTION
LEVER
MECHANISM

CODEBAR EXTENSION
BAIL MECHANISM

CODEBAR
EXTENSION
MECHANISM

CLUTCH TRIPBAR
LINK MECHANISM

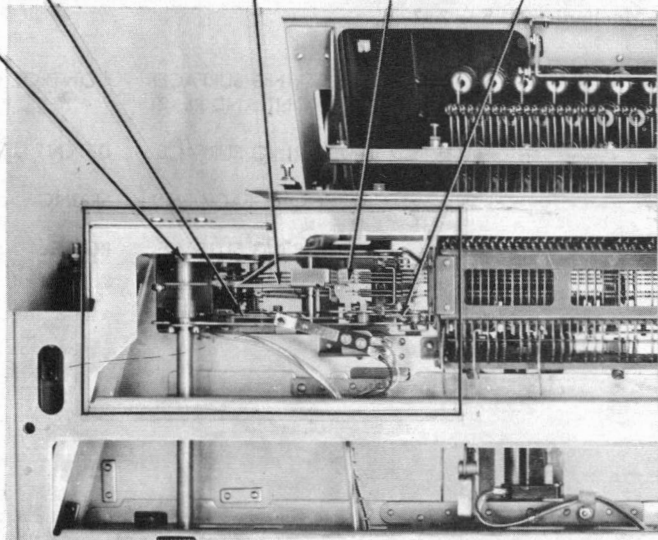

28 PERFORATOR-
TRANSMITTER-
BASE
LUBRI-
CATION

P34.530

Page 9

2.08 Detent Lever Mechanism — See 2.07

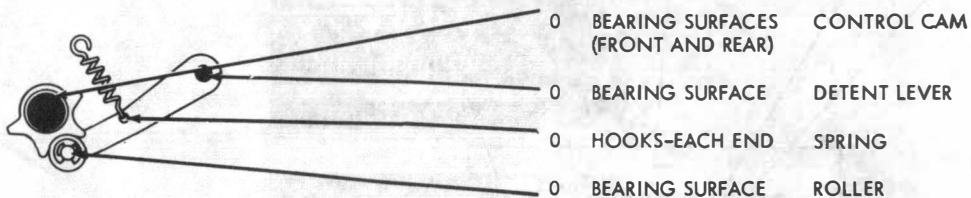

2.09 Selection Lever Mechanism — See 2.07

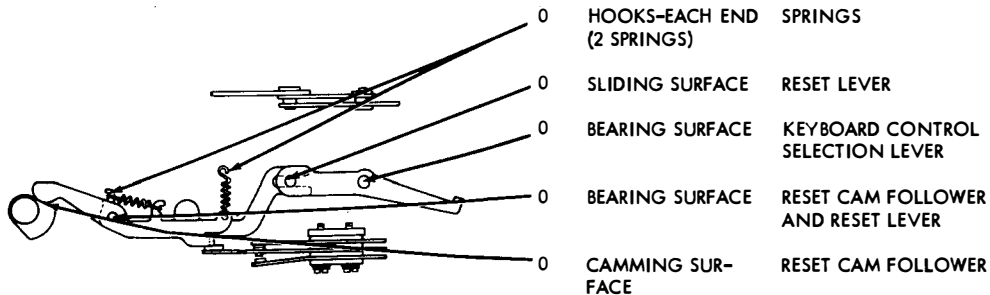

28 PERFORATOR-
TRANSMITTER-
BASE
LUBRI-
CATION

P34.530

Page 11

2.10 Codebar Extension Bail Mechanism — See 2.07

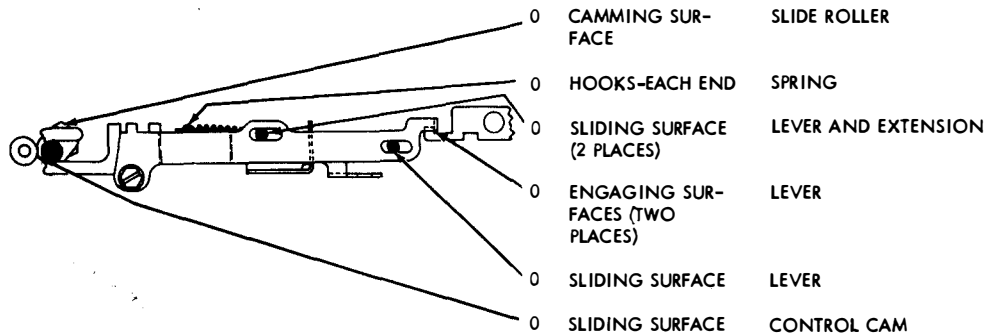

2.11 Codebar Extension Mechanism — See 2.07

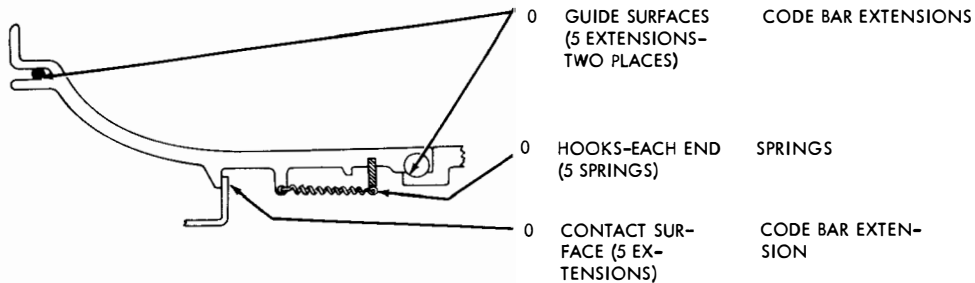

2.12 Clutch Tripbar Link Mechanism — See 2.07

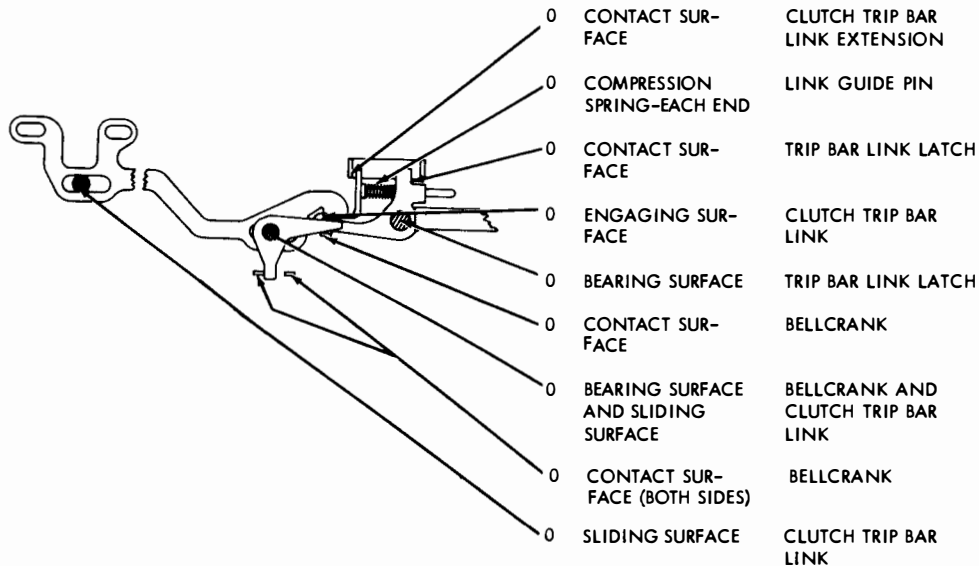

213 Keyboard Mechanism — Top View

CODEBAR
MECHANISM

CODELEVER
UNIVERSAL
BAIL MECHANISM

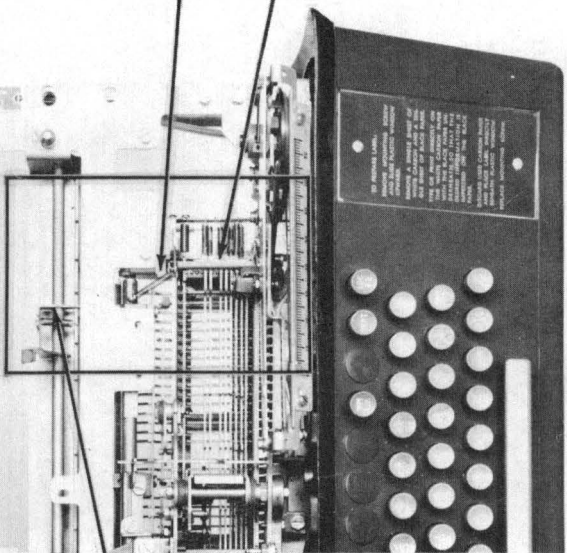

LOCAL CARRIAGE
RETURN MECHANISM

28 PERFORATOR-
TRANSMITTER-

P34.530

BASE
LUBRI-
CATION

2.14 Codebar Mechanism — See 2.13

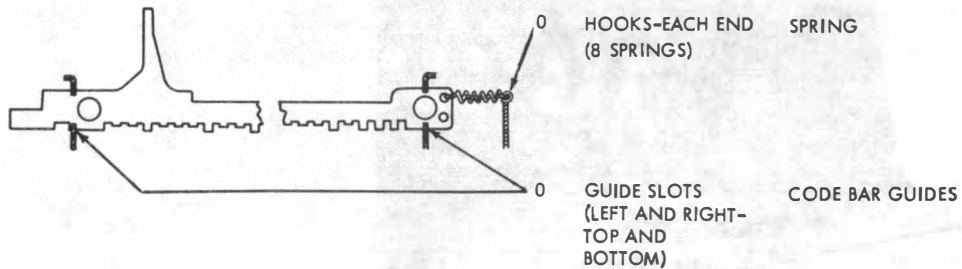

2.15 Codelever Universal Bail Mechanism — See 2.13

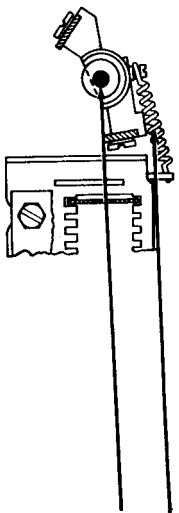

0	HOOKS-EACH END	SPRING
02	BEARING SURFACE	CODE LEVER UNIVER- SAL BAIL

28 PERFORATOR-
TRANSMITTER-

P34.530

BASE
LUBRI-
CATION

2.16 Local Carriage Return Mechanism — See 2.13

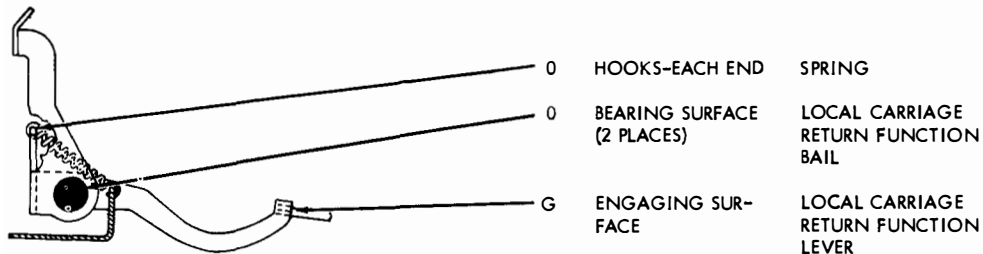

2.17 Keyboard Mechanism — Rear View

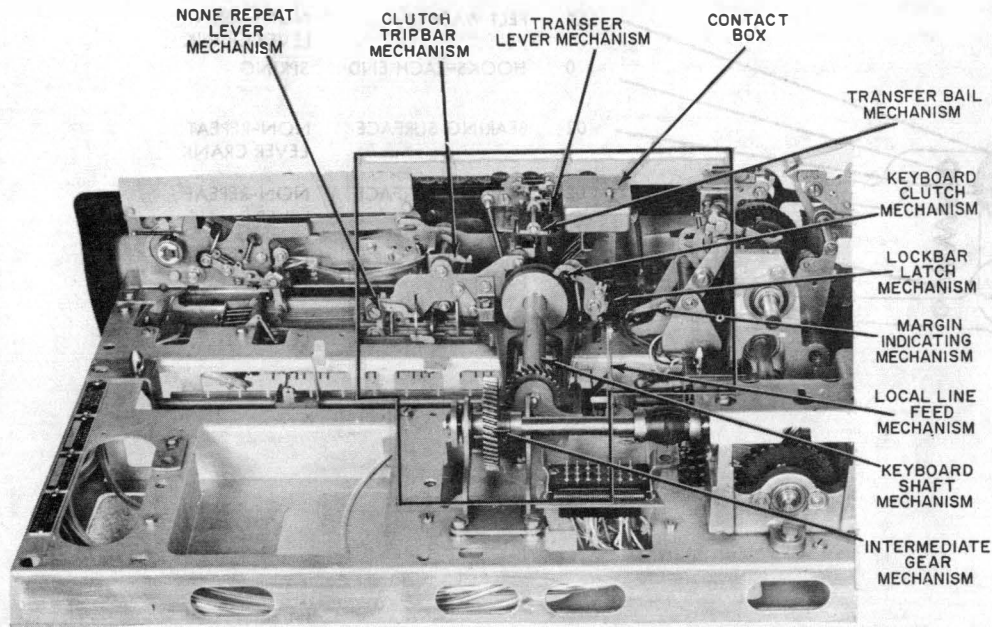

28 PERFORATOR-
TRANSMITTER-
BASE
LUBRI-
CATION

P34.530

Page 19

2.18 Nonrepeat Lever Mechanism — See 2.17

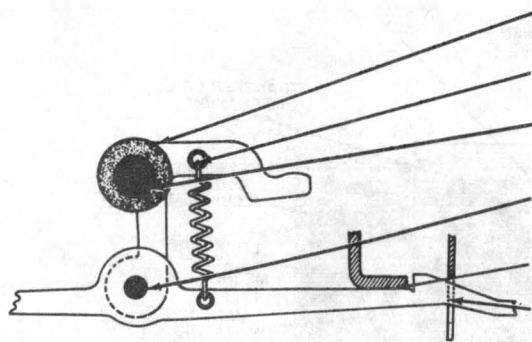

SAT	FELT WASHER	NON-REPEAT LEVER CRANK SPRING
0	HOOKS-EACH END	
02	BEARING SURFACE	NON-REPEAT LEVER CRANK
02	BEARING SURFACE	NON-REPEAT LEVER
G	ENGAGING SUR- FACE	NON-REPEAT LEVER
02	GUIDE SLOT	NON-REPEAT LEVER

2.19 Clutch Tripbar Mechanism — See 2.17

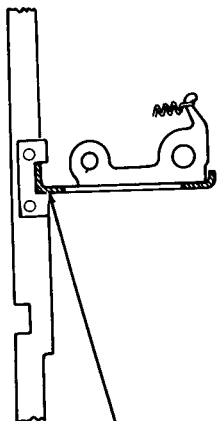

G SAT
SLOT

CLUTCH TRIP BAR
WEAR PLATE

28 PERFORATOR-
TRANSMITTER-

P34.530

BASE
LUBRI-
CATION

2.20 Transfer Lever Mechanism — See 2.17

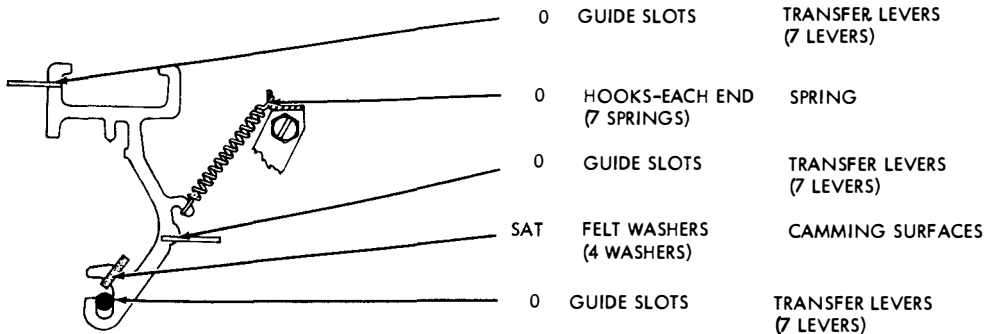

2.21 Contact Box — See 2.17

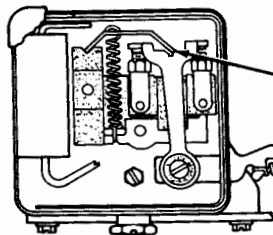

DISASSEMBLY: REMOVE NUT AND LOCK WASH-
ER SECURING CONTACT BOX
COVER AND REMOVE COVER.

- | | | |
|---|-----------------------|----------------|
| G | ENGAGING SUR-
FACE | CONTACT TOGGLE |
| O | HOOKS-EACH END | SPRING |

2.22 Transfer Bail Mechanism — See 2.17

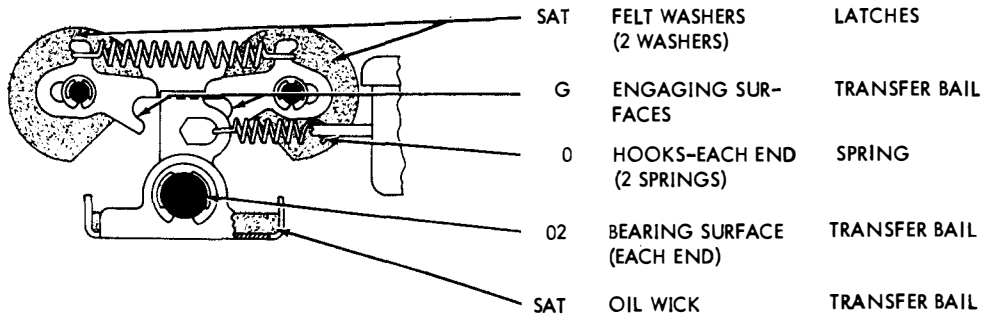

2.23 Keyboard Clutch Mechanism — See 2.17

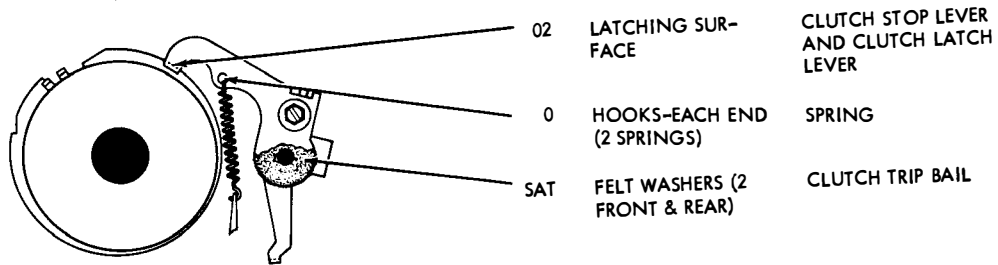

2.24 Lockbar Latch Mechanism — See 2.17

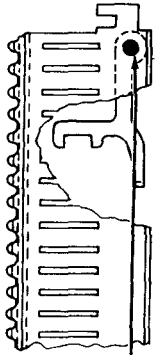

0

BEARING SURFACE

LOCK BAR LATCH



2.25 Margin Indicating Mechanism — See 2.17

Note: If a switch is equipped with a nylon actuator, lubricant shall **not** be applied to the engaging surface.

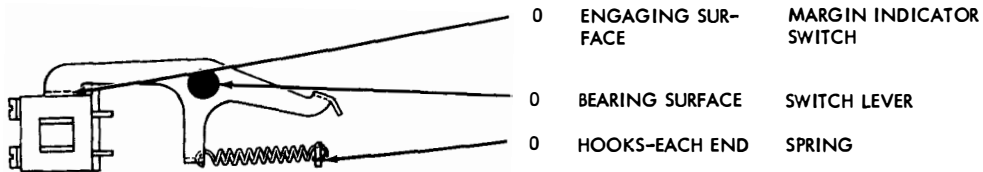

28 PERFORATOR-
TRANSMITTER-
BASE
LUBRI-
CATION

P34.530

Page 27

2.26 Local Line-feed Mechanism — See 2.17

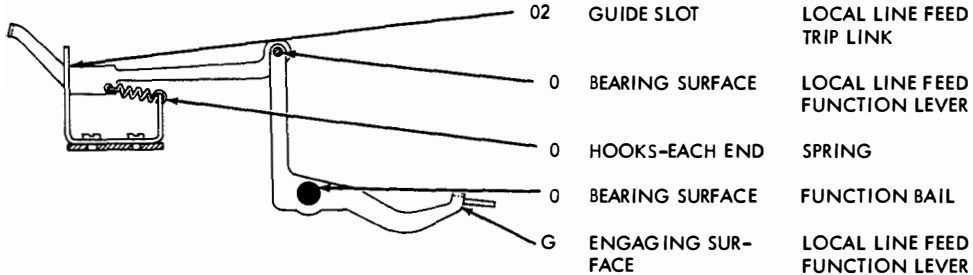

2.27 Keyboard Shaft Mechanism — See 2.17

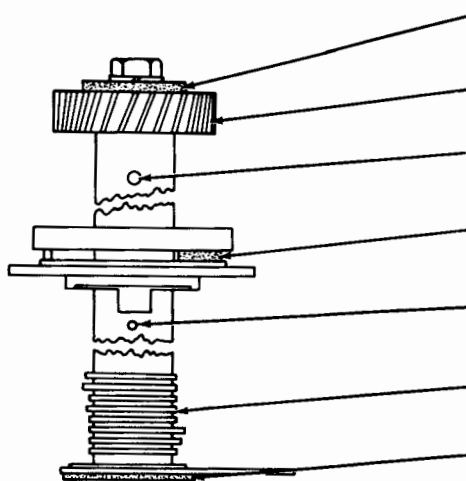

SAT	FELT WASHER	SIGNAL GENERATOR SHAFT
G	GEAR TEETH	SIGNAL GENERATOR SHAFT
020	OIL HOLE	SIGNAL GENERATOR SHAFT
04	INTERNAL MECH- ANISM	KEYBOARD CLUTCH
SAT	FELT WICK	
020	OIL HOLE	SIGNAL GENERATOR CAM
02	CAMMING SUR- FACE EACH CAM	SIGNAL GENERATOR CAM
SAT	FELT WASHER	SIGNAL GENERATOR SHAFT

28 PERFORATOR-
TRANSMITTER-
BASE
LUBRI-
CATION

P34.530

Page 29

2.28 Intermediate Gear Mechanism — See 2.17

Note: Lubrication instructions for the motor unit are given in the section containing the lubrication details for the 28 Motor.

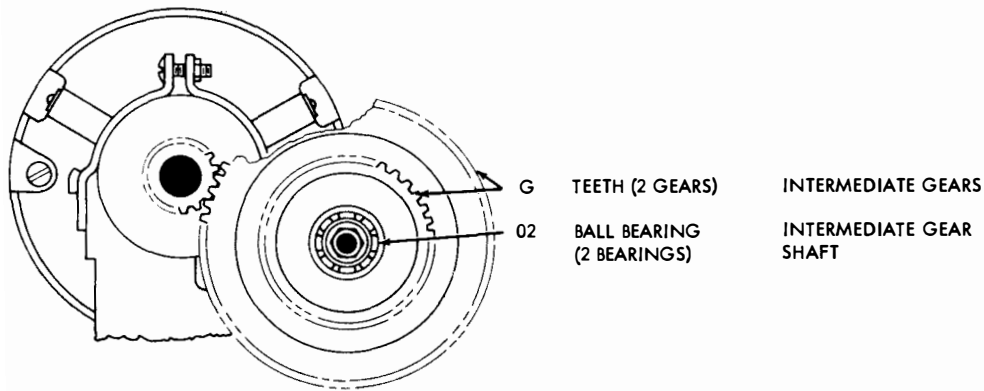

2.29 Keyboard Mechanism — Right Side View

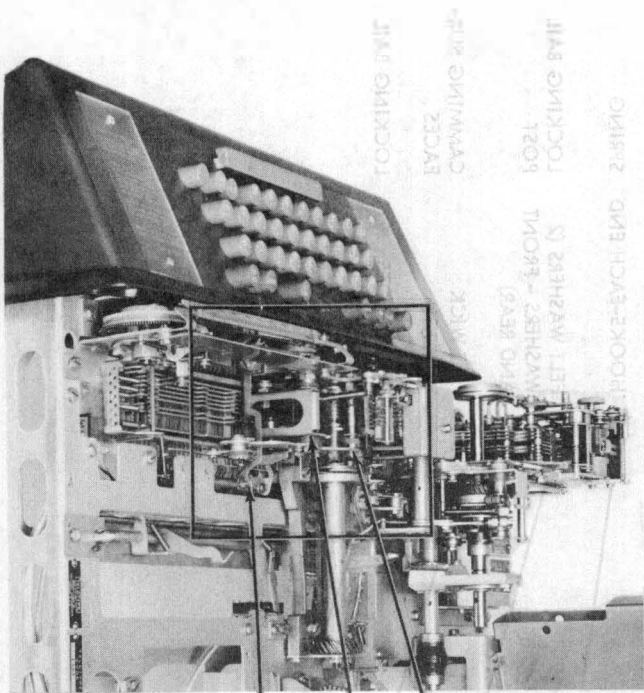

LOCKING BAIL MECHANISM

CODEBAR BAIL MECHANISM

UNIVERSAL BAIL LATCH LEVER MECHANISM

28 PERFORATOR-
TRANSMITTER-

P34.530

BASE
LUBRI-
CATION

2.30 Locking Bail Mechanism — See 2.29

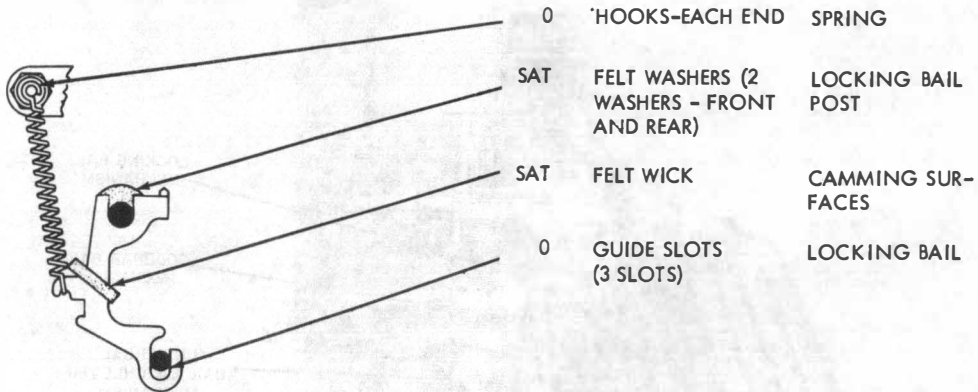

2.31 Codebar Bail Mechanism — See 2.29

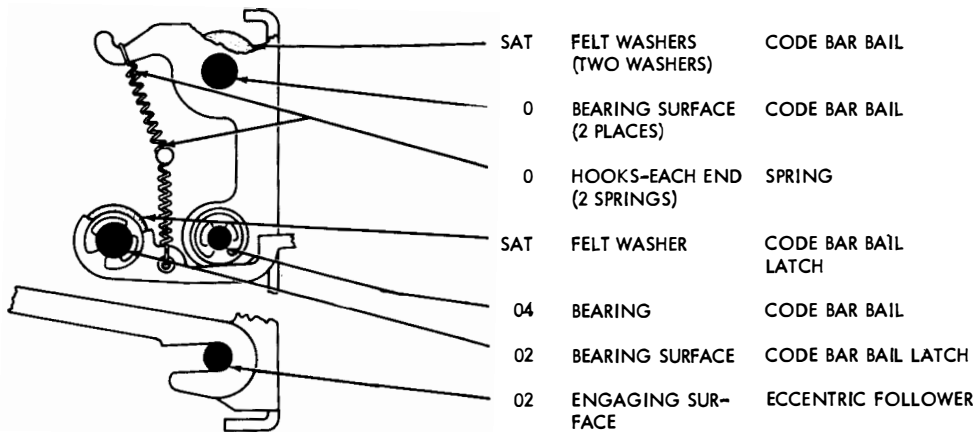

28 PERFORATOR-
TRANSMITTER-
BASE
LUBRI-
CATION

P34.530

Page 33

2.32 Universal Bail Latchlever Mechanism — See 2.29

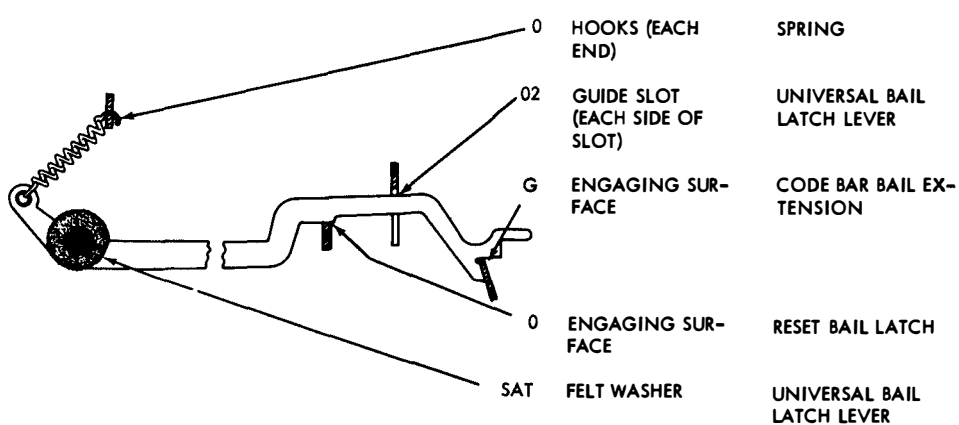

2.33 Tape-out Switch Mechanism — See 2.56

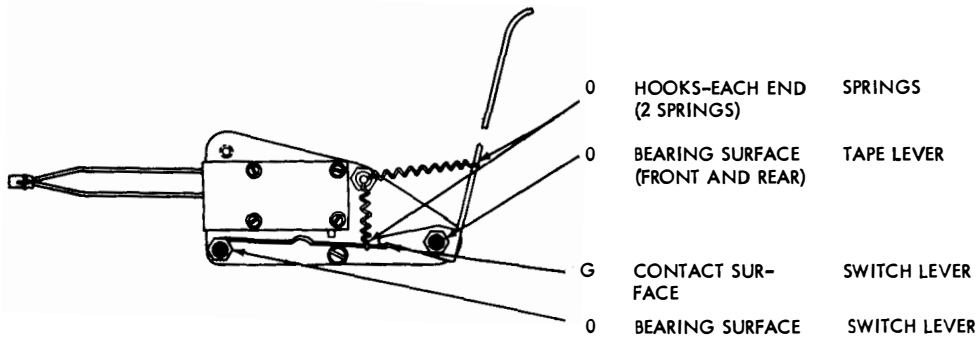

28 PERFORATOR-
TRANSMITTER-
BASE
LUBRI-
CATION

P34.530

Page 35

2.34 Electrical Line-break Mechanism — See 2.41

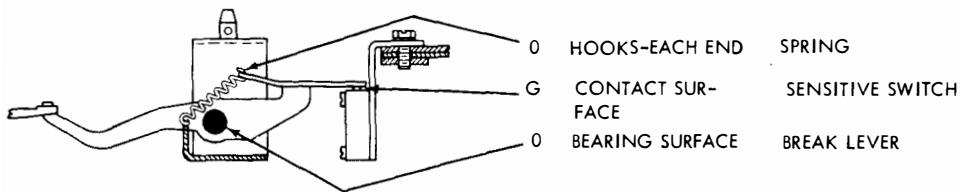

2.35 Keyboard Mechanism — Right Side View

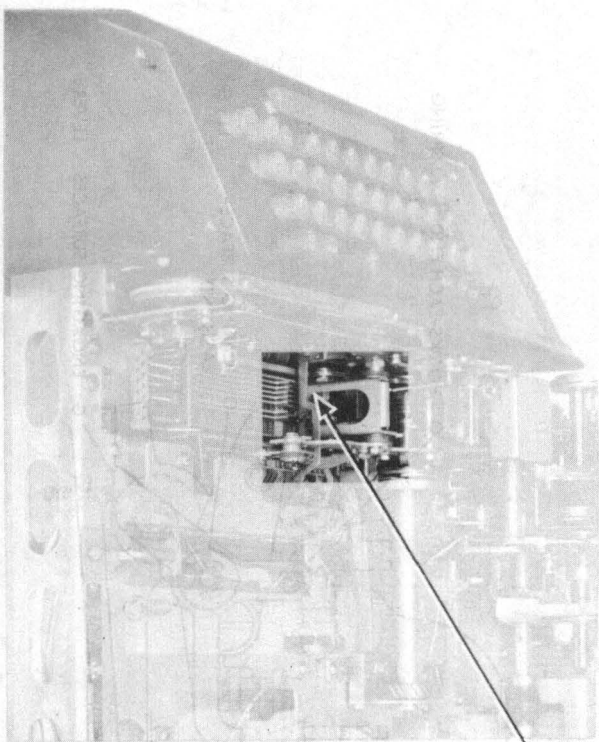

REPEAT-ON-SPACE
MECHANISM

28 PERFORATOR-
TRANSMITTER-
BASE
LUBRI-
CATION

P34.530

Page 37

2.36 Repeat-on-Space Mechanism — Later Design — See 2.35

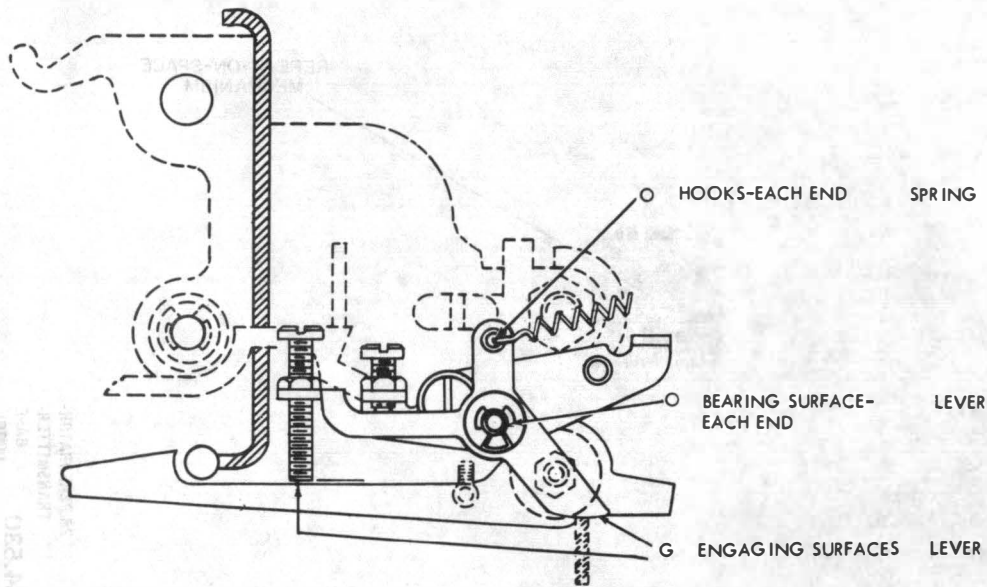

2.37 Repeat-on-Space Mechanism — Earlier Design — See 2.35

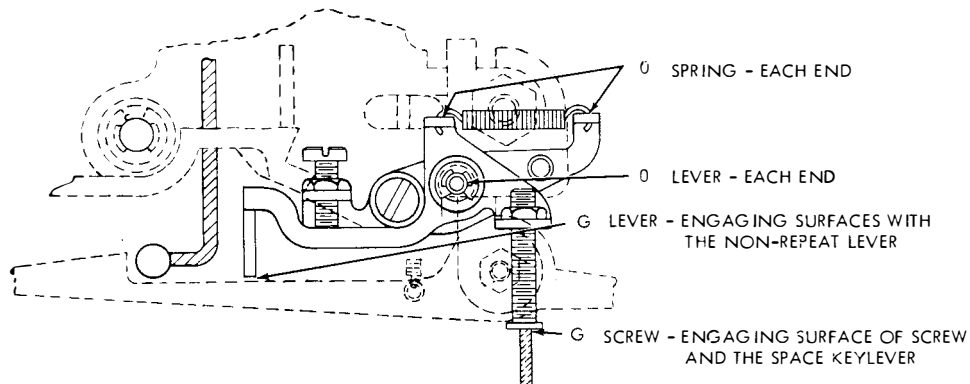

28 PERFORATOR-
TRANSMITTER-
BASE
LUBRI-
CATION

P34.530

Page 39

2.38 "HERE IS" Keylever Contact Mechanism (TWX)

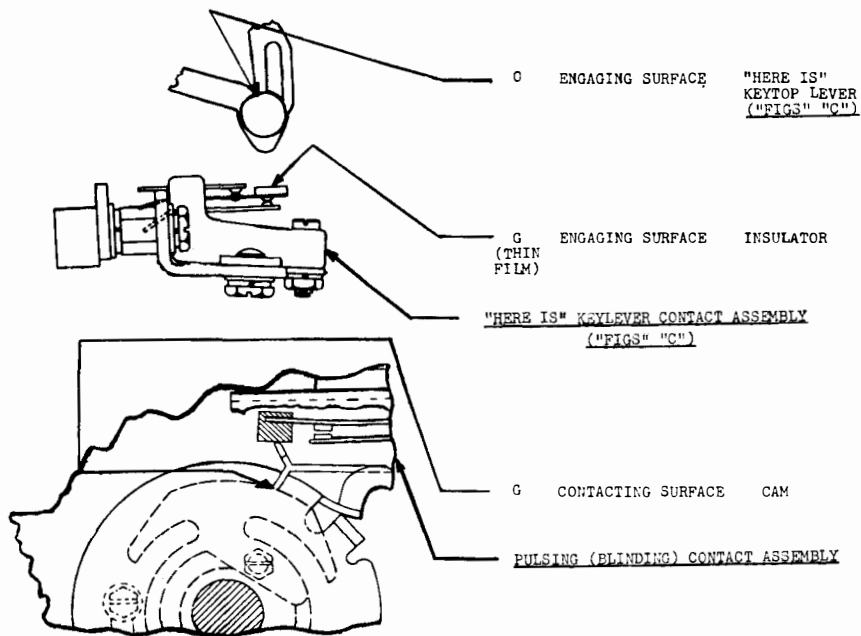

2.39 Time-delay Mechanism

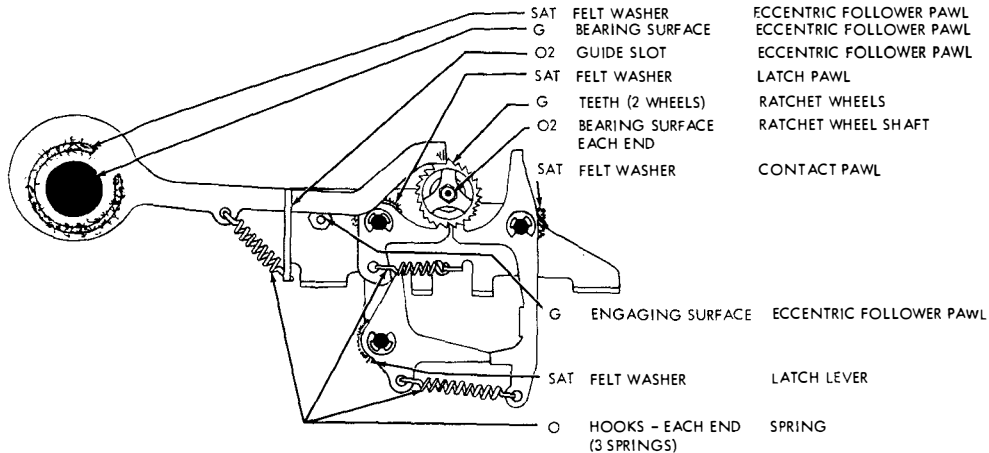

28 PERFORATOR-
 TRANSMITTER-
 BASE
 LUBRI-
 CATION

P34.530

Page 41

2.40 Form Feed-out Mechanism

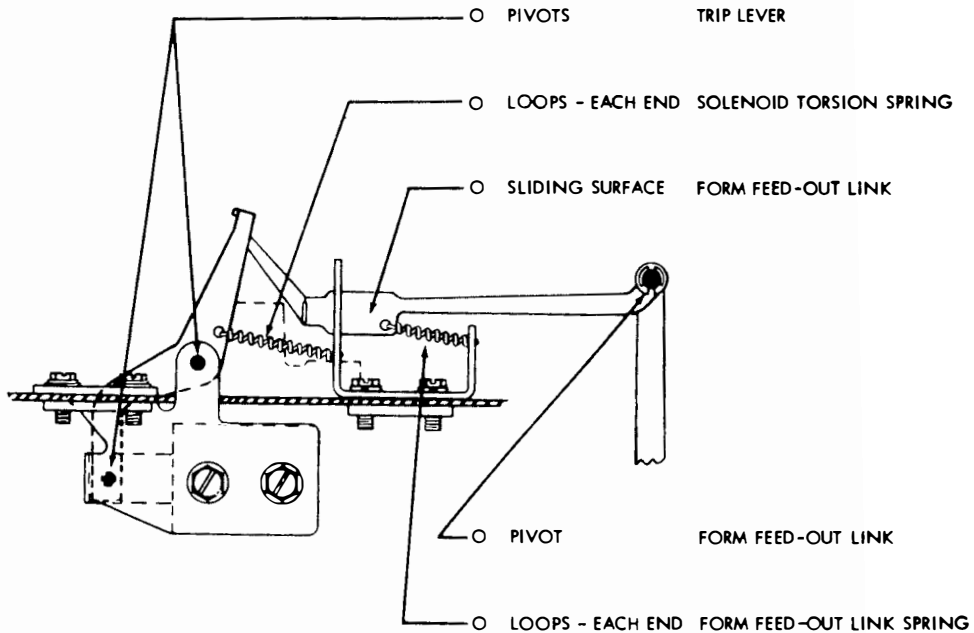

2.41 Keyboard Mechanism — Rear View

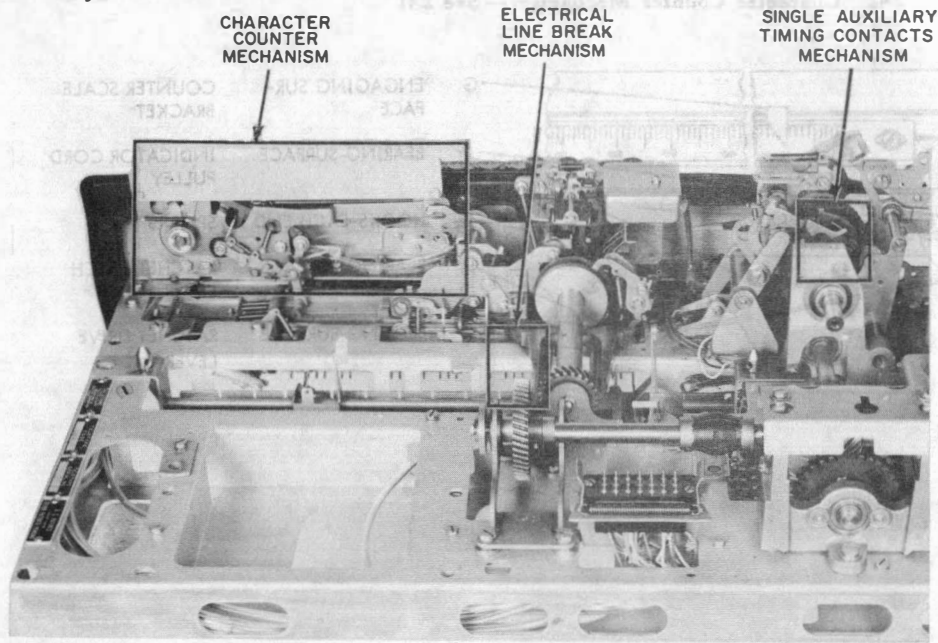

26 PERFORATOR-
TRANSMITTER-
BASE
LUBRI-
CATION

P34.530

Page 43

2.42 Character Counter Mechanism — See 2.41

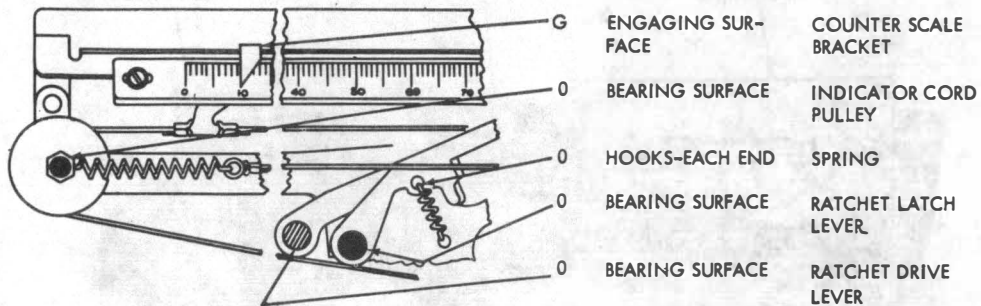

2.43 Character Counter Mechanism — See 2.41

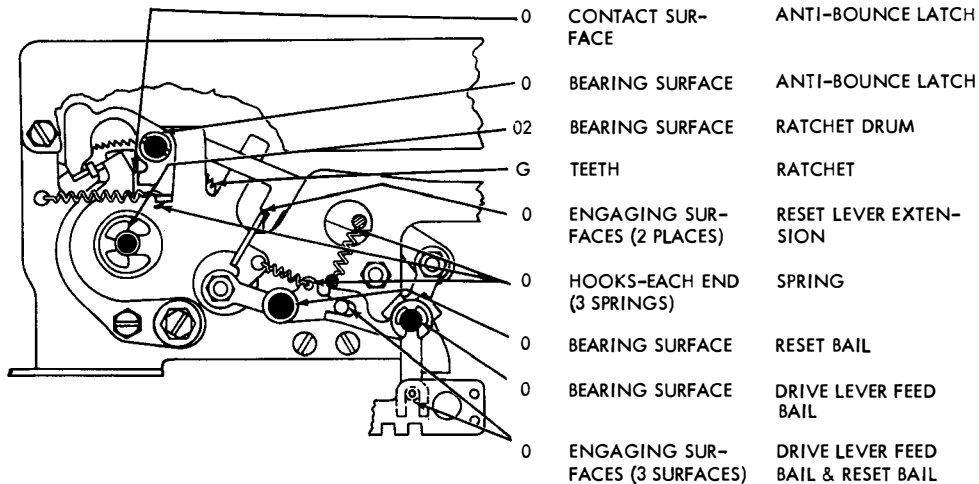

2.44 Remote-control Gear Shift Mechanism

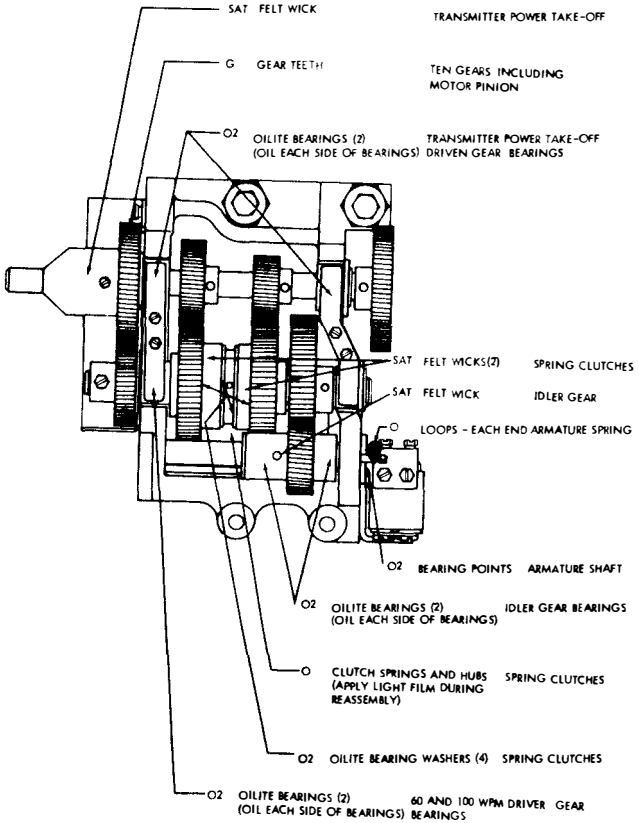

B. Typing and Nontyping Perforators

2.45 Typing and Nontyping Perforator Mechanism — Top View

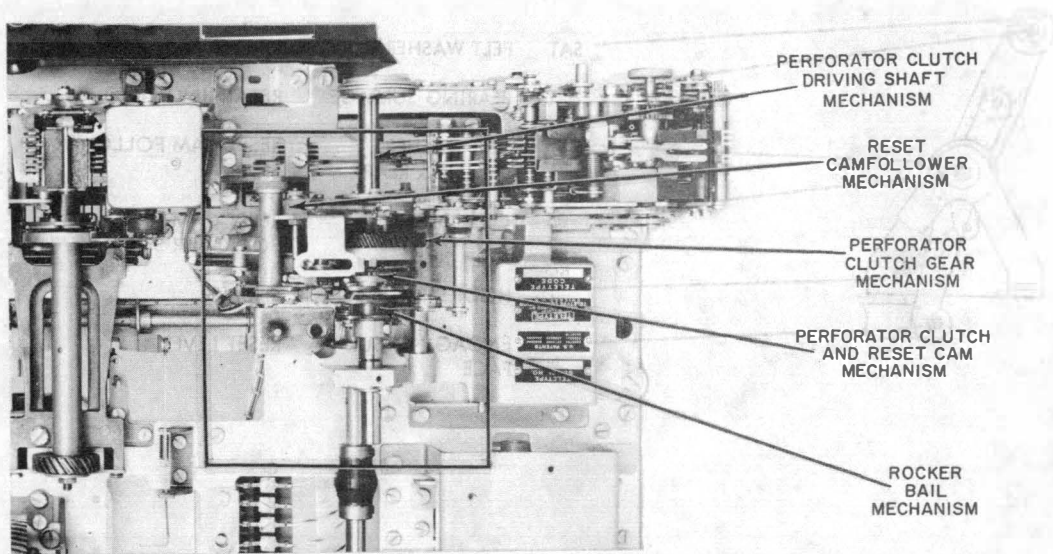

28 PERFORATOR-
TRANSMITTER-
BASE
LUBRI-
CATION

P34.530

Page 47

2.46 Reset Camfollower Mechanism — Typing and Nontyping Perforators — See 2.45

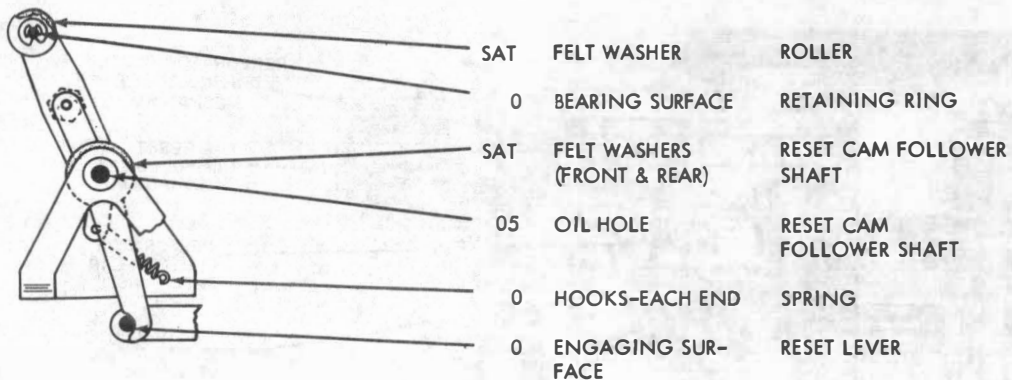

2.47 Rocker Bail Mechanism — Nontyping Perforator Only — See 2.45

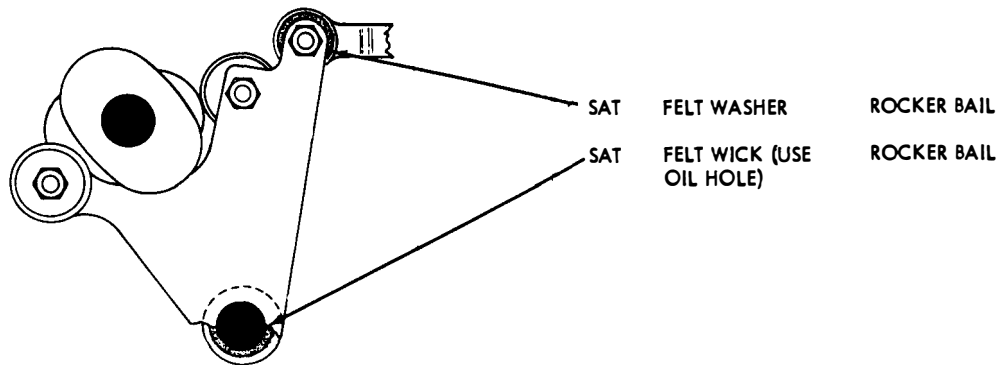

2.48 Perforator Clutch Driving Shaft Mechanism — Nontyping Perforator Only — See 2.45

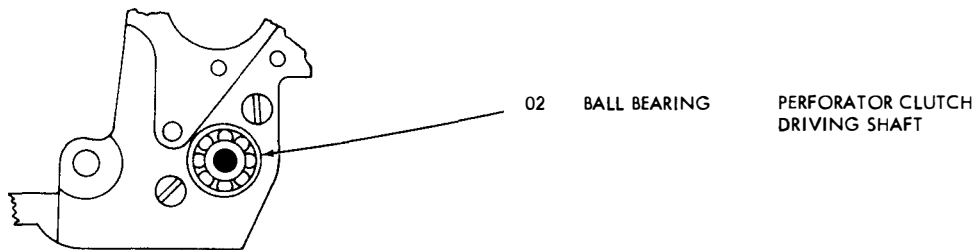

2.49 Perforator Clutch and Reset Cam Mechanism — Nontyping Perforator Only — See 2.45

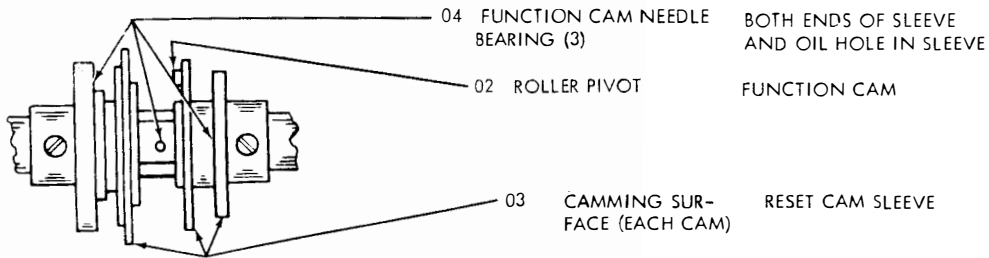

28 PERFORATOR-
TRANSMITTER-
BASE
LUBRI-
CATION

P34.530

Page 51

2.50 Perforator Clutch Mechanism — Nontyping Perforator Only — See 2.45

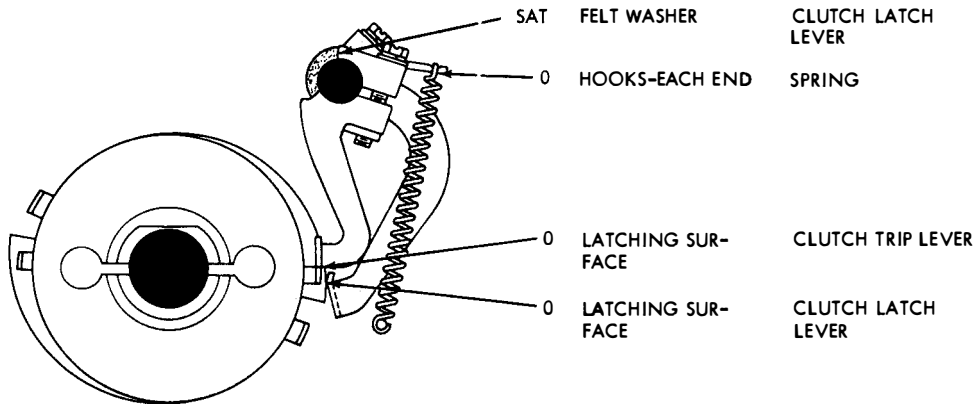

2.51 Perforator Clutch Gear Mechanism — Nontyping Perforator Only — See 2.45

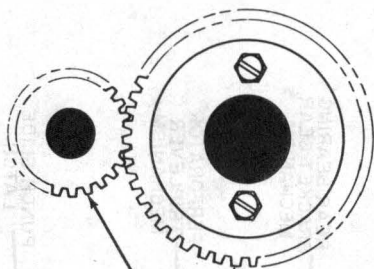

G
GEAR TEETH

PERFORATOR CLUTCH
DRIVE AND DRIVEN
GEARS

28 PERFORATOR-
TRANSMITTER-

P34.530

BASE
LUBRI-
CATION

2.52 Typing and Nontyping Perforator Mechanism — Front View

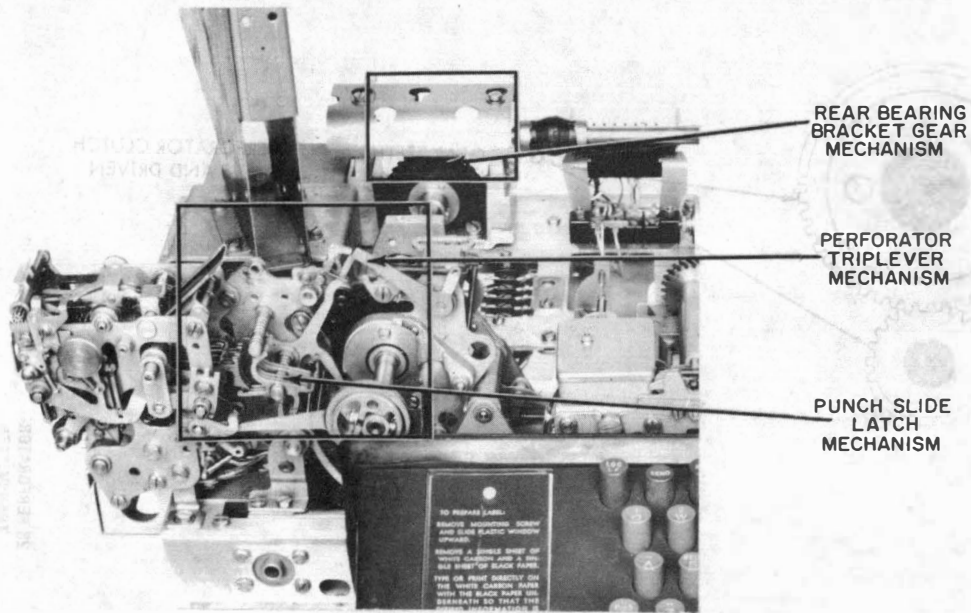

2.53 Rear Bearing Bracket Gear Mechanism — Typing and Nontyping Perforators — See 2.52

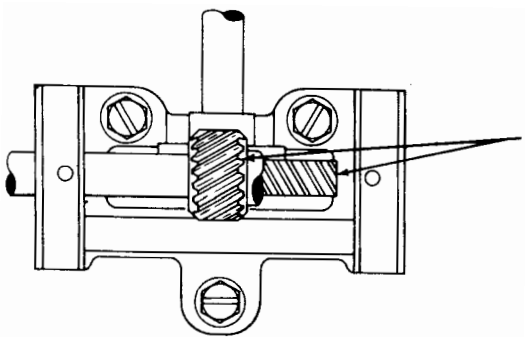

G GEAR TEETH

REAR BEARING BRACKET GEAR

28 PERFORATOR-
TRANSMITTER-
BASE
LUBRI-
CATION
P34.530
Page 55

2.54 Perforator Triplever Mechanism — Nontyping Perforator Only — See 2.52

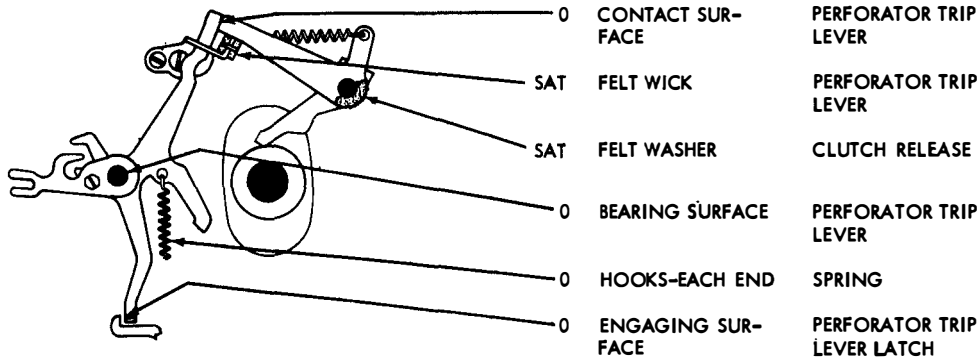

2.55 **Punch Slide Latch Mechanism for Chadless Tape or Fully Perforated Tape — Typing and Nontyping Perforators — See 2.52**

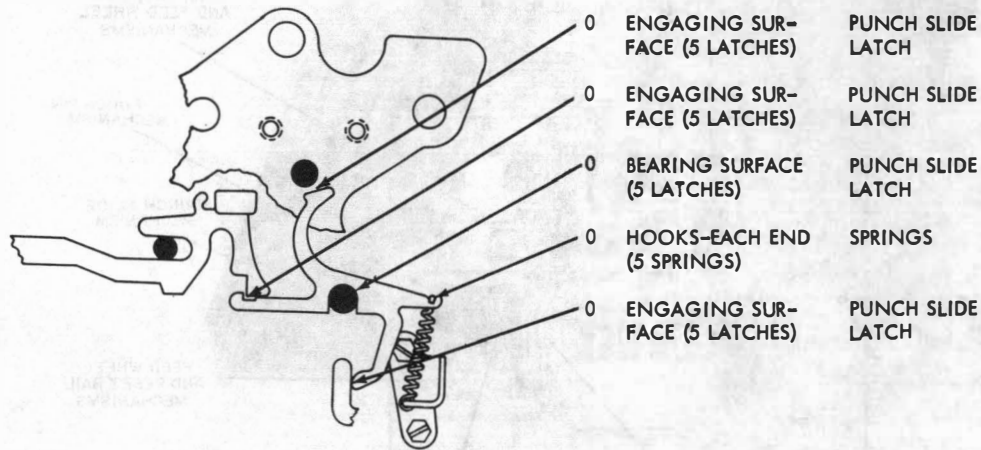

28 PERFORATOR-
TRANSMITTER-
BASE
LUBRI-
CATION

P34.530

Page 57

2.56 Typing and Nontyping Perforator Mechanism — Left-side View

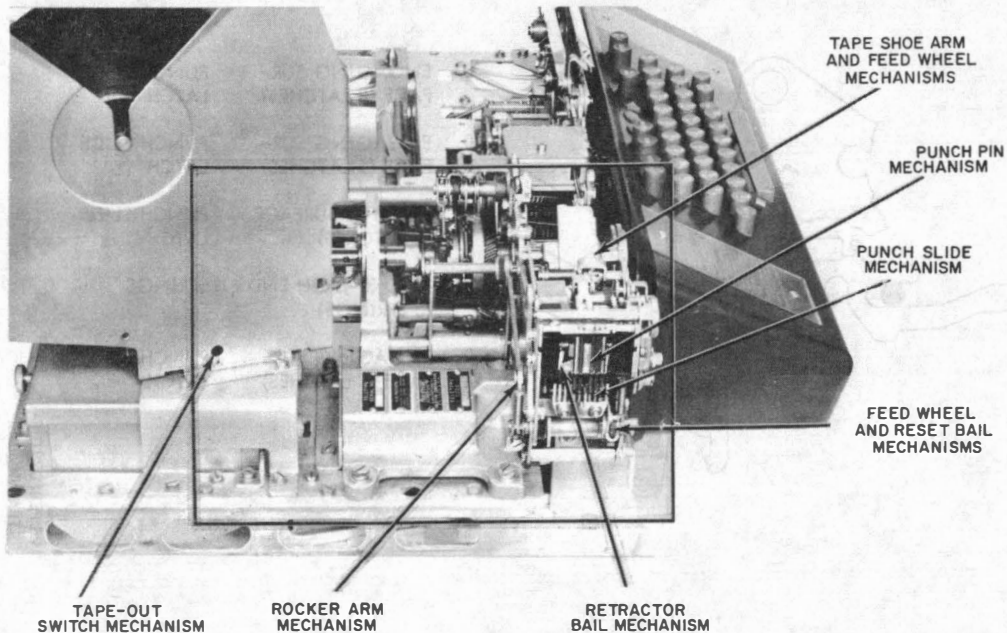

2.57 Tape Shoe Arm Mechanism for Chadless Tape or Fully Perforated Tape — Typing and Nontyping Perforators — See 2.56

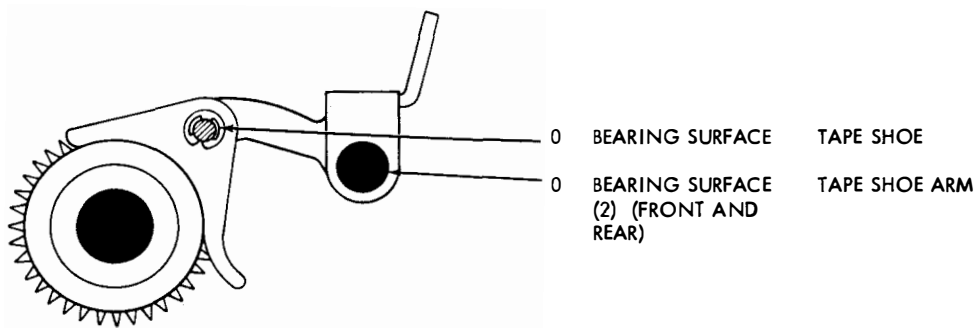

28 PERFORATOR-
TRANSMITTER-
BASE
LUBRI-
CATION

P34.530
Page 59

2.58 Retractor Bail Mechanism for Chadless Tape of Fully Perforated Tape — Typing and Nontyping Perforators — See 2.56

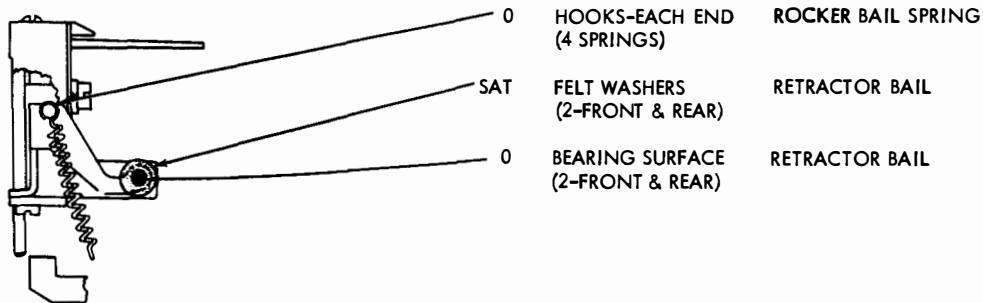

2.59 Punch Pin Penetration for Chadless Tape Only — Typing and Nontyping Perforators —
See 2.56

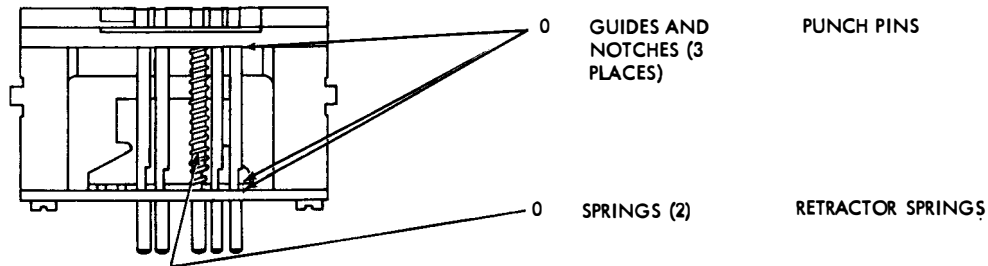

28 PERFORATOR-
TRANSMITTER-
BASE
LUBRI-
CATION

P34.530

Page 61

2.60 **Punch Slide Mechanism for Chadless Tape or Fully Perforated Tape — Typing and Non-typing Perforators — See 2.56**

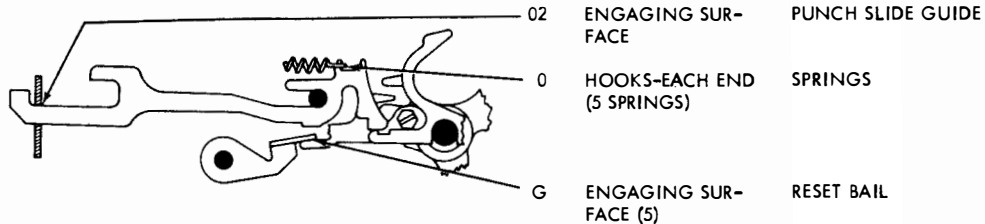

2.61 Feed Wheel Mechanism for Chadless Tape Only — Typing and Nontyping Perforators —
See 2.56

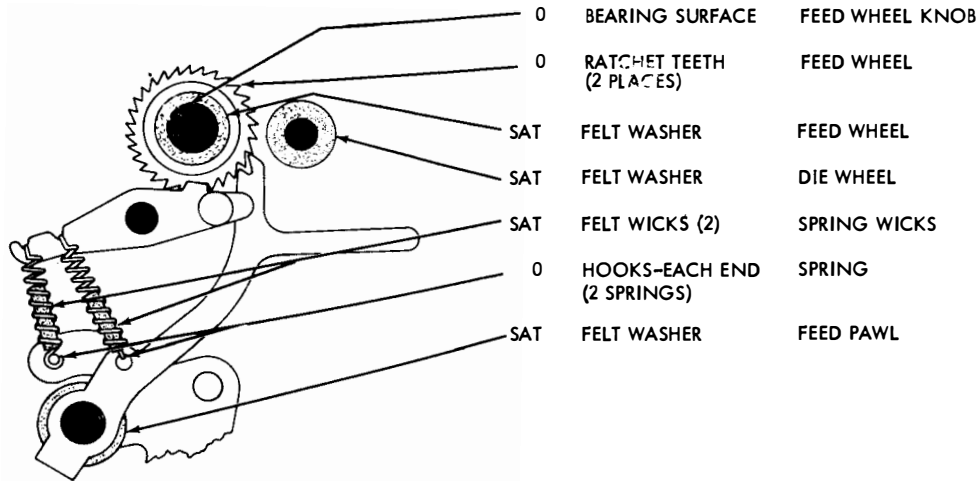

28 PERFORATOR-
TRANSMITTER-
BASE
LUBRI-
CATION

P34.530

Page 63

2.62 **Punch Pin Penetration for Fully Perforated Tape Only — Typing and Nontyping Perforators — See 2.56**

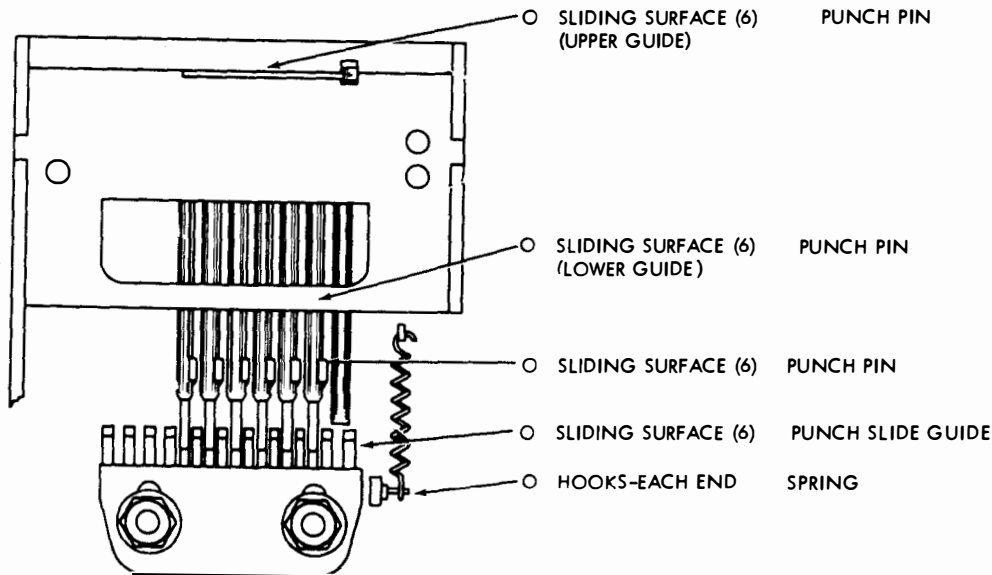

2.63 Feed Wheel Mechanism for Fully Perforated Tape Only — Typing and Nontyping Perforators — See 2.56

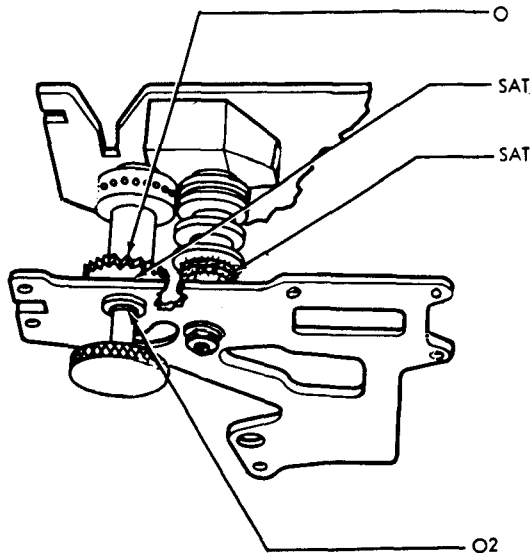

RATCHET TEETH (2) FEED WHEEL

PIVOT POINT (FELT WASHER) FEED WHEEL

PIVOT POINT (FELT WASHER) DIE WHEEL

PIVOT POINTS (2) HANDWHEEL BEARING

28 PERFORATOR-
TRANSMITTER-
BASE
LUBRI-
CATION

P34.530

Page 65

2.64 **Reset Bail Mechanism for Chadless Tape or Fully Perforated Tape — Typing and Non-typing Perforators — See 2.56**

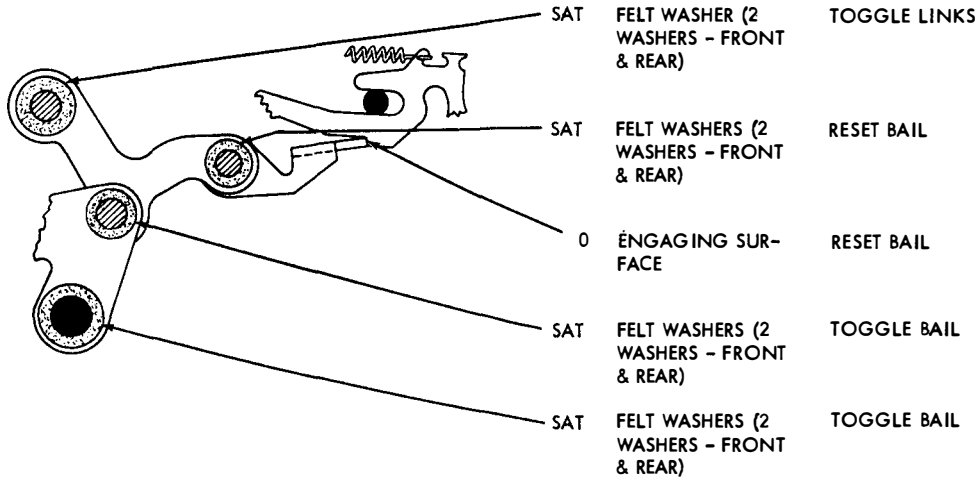

2.65 **Rocker Arm Mechanism for Chadless Tape or Fully Perforated Tape — Typing and Non-typing Perforators — See 2.56**

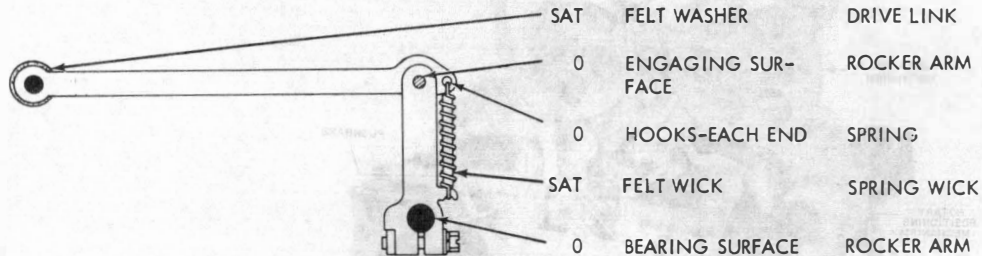

28 PERFORATOR-
TRANSMITTER-
BASE
LUBRI-
CATION

P34.530

Page 67

2.66 Typing Perforator Mechanism Only — Front View

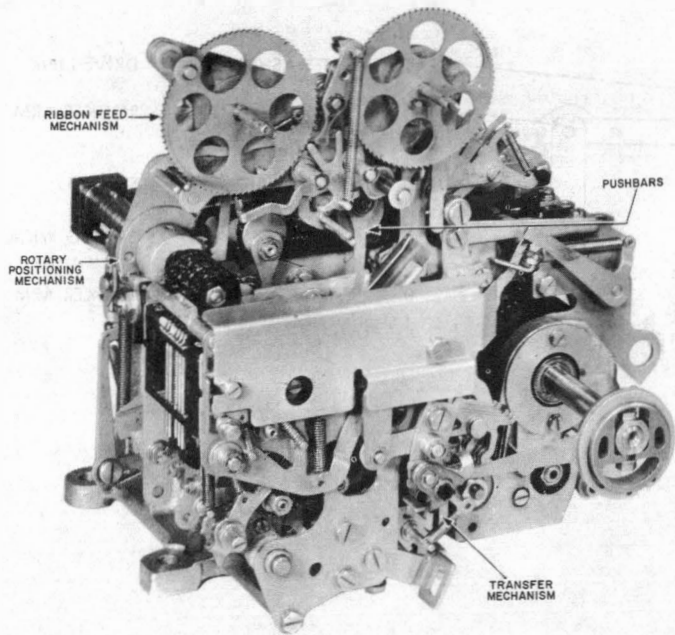

2.67 Ribbon-feed Mechanism — Later Design — Typing Perforator Only — See 2.66

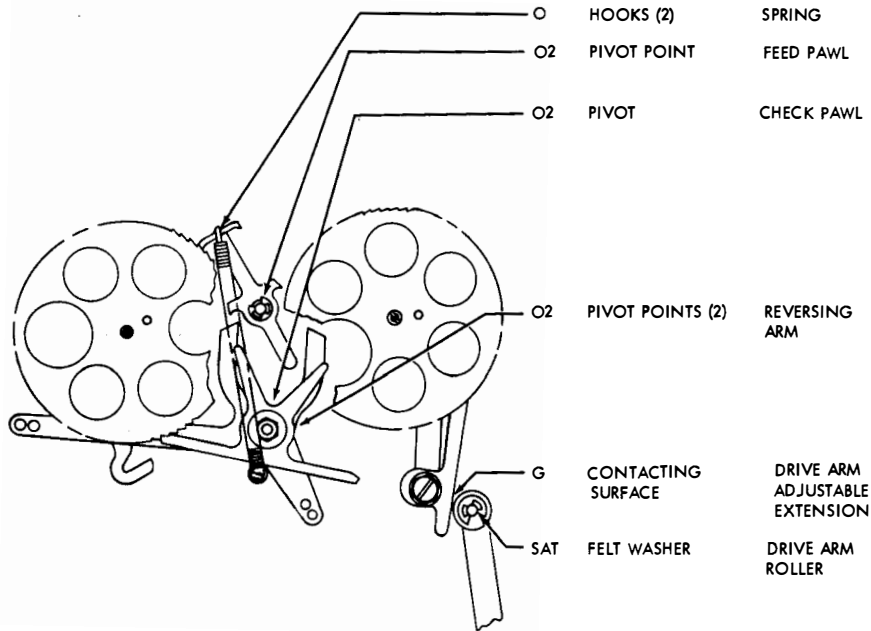

28 PERFORATOR-
TRANSMITTER-
BASE
LUBRI-
CATION

P34.530

Page 69

2.68 Ribbon-feed Mechanism — Later Design — Rear View Typing Perforator Only — See 2.66

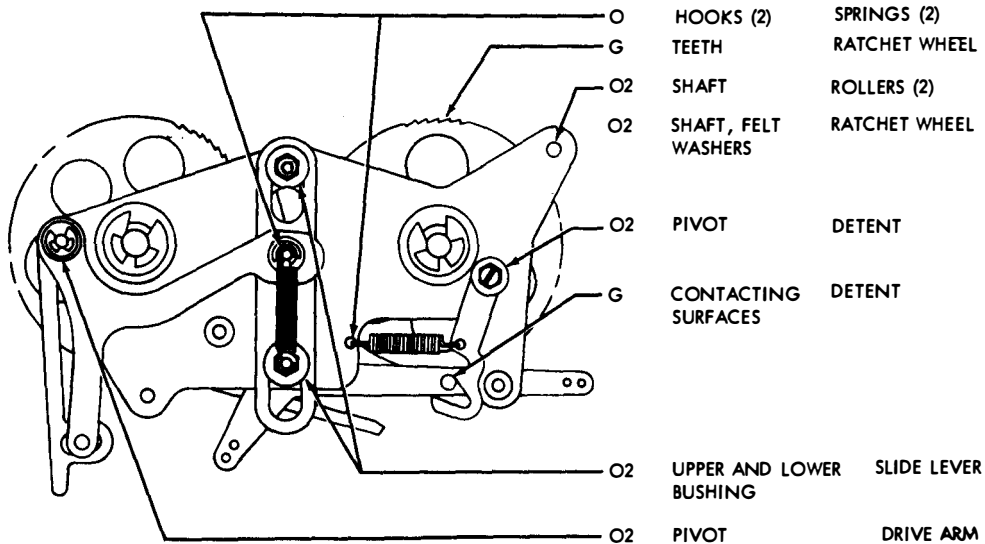

2.69 Ribbon-feed Mechanism — Earlier Design — Typing Perforator Only — See 2.66

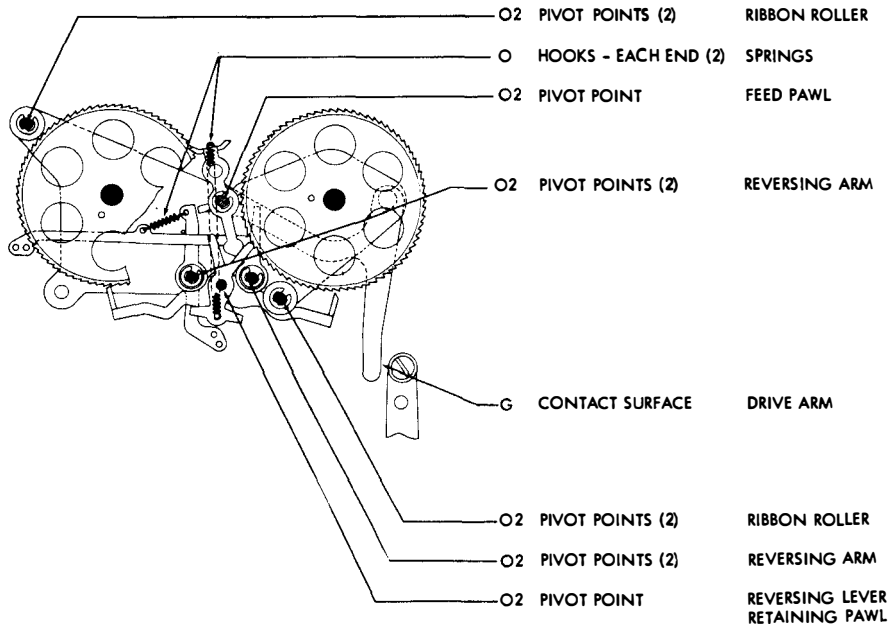

28 PERFORATOR-
TRANSMITTER-
BASE
LUBRI-
CATION

P34.530

Page 71

**2.70 Ribbon-feed Mechanism — Earlier Design — Rear View Typing Perforator Only —
See 2.66**

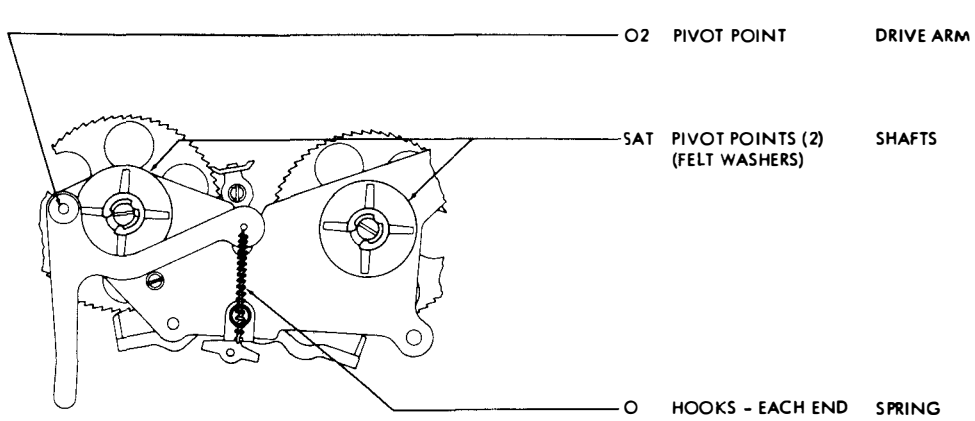

2.71 Rotary Positioning Mechanism — Typing Perforator Only — See 2.66

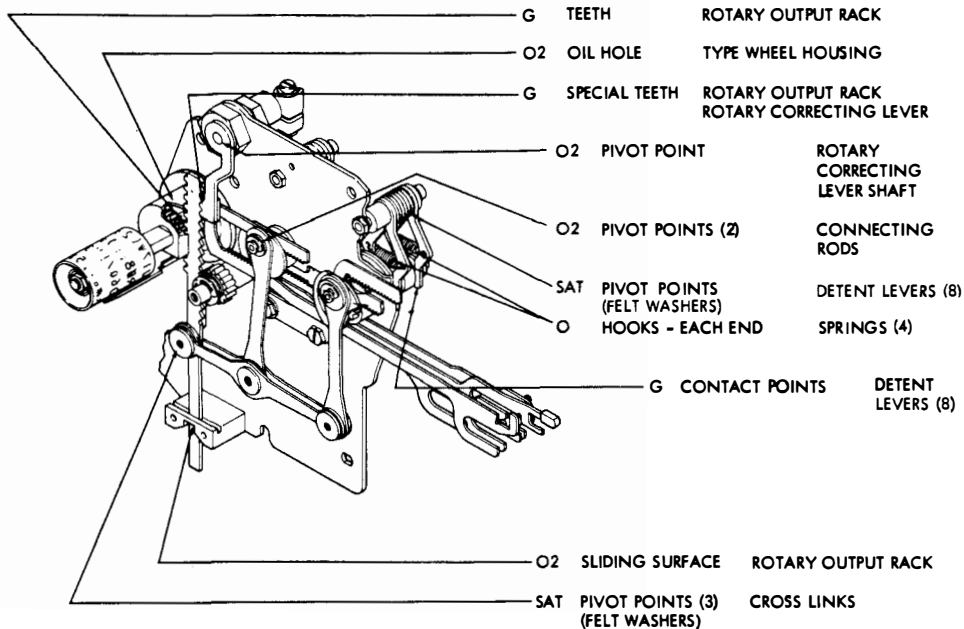

28 PERFORATOR-
 TRANSMITTER-
 BASE
 LUBRI-
 CATION

P34.530

Page 73

2.72 Transfer Mechanism — Typing Perforator Only — See 2.66

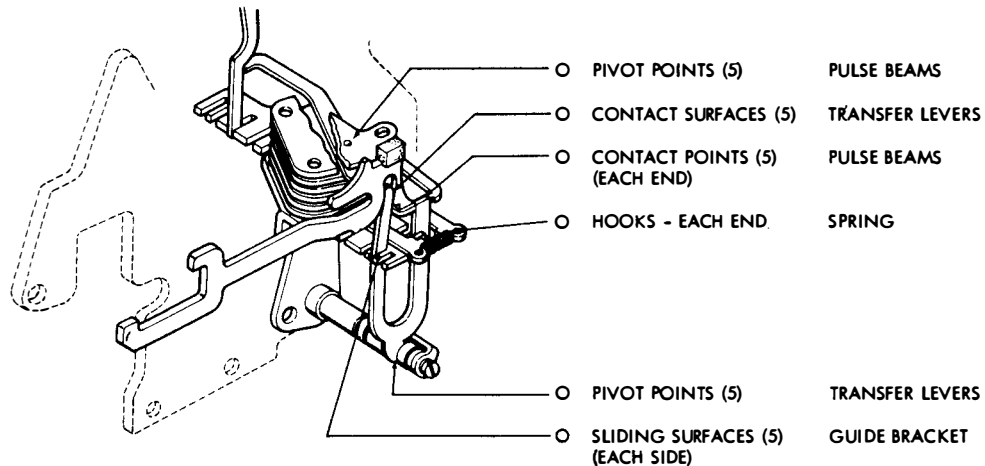

2.73 Pushbars — Typing Perforator Only — See 2.66

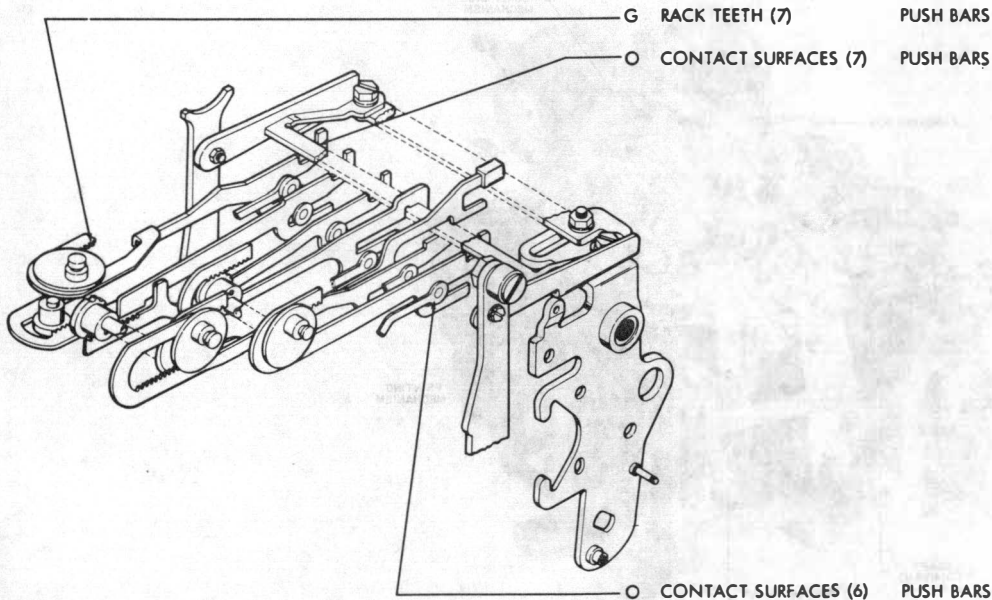

28 PERFORATOR-
TRANSMITTER-
BASE
LUBRI-
CATION

P34.530

Page 75

2.74 Typing Perforator Mechanism — Rear View

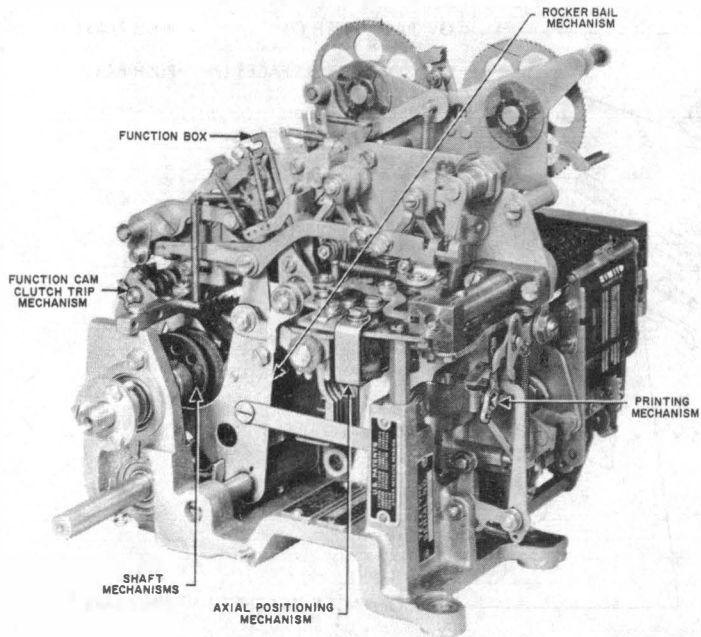

2.75 **Function-cam Clutch Trip Mechanism — Typing Perforator Only — See 2.74**

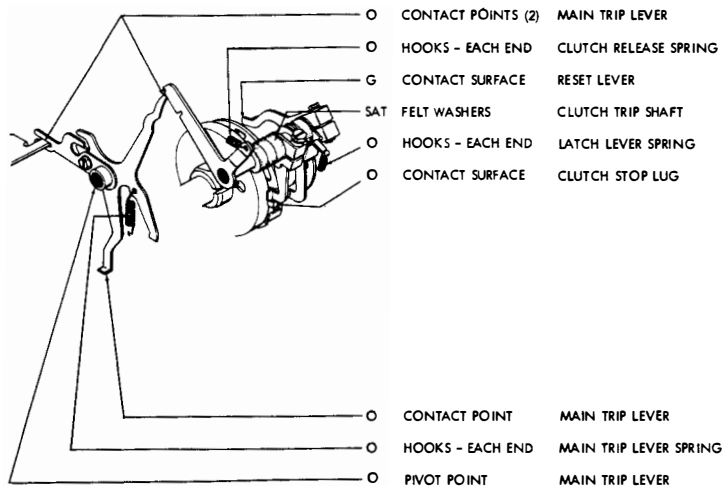

28 PERFORATOR-
TRANSMITTER-
BASE
LUBRI-
CATION

P34.530

Page 77

2.76 Function Box — Typing Perforator Only — Rear View — See 2.74

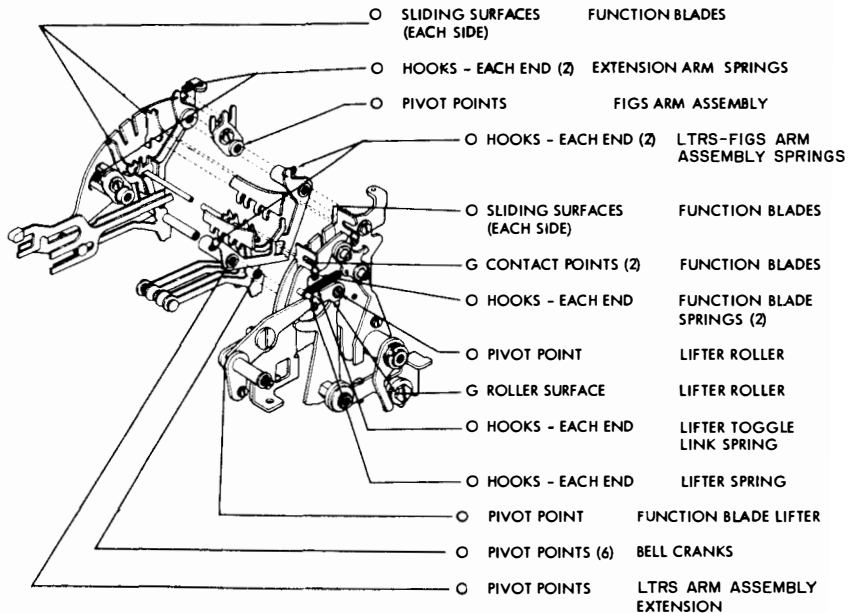

2.77 Axial Positioning Mechanism — Rear View — Typing Perforator Only — See 2.74

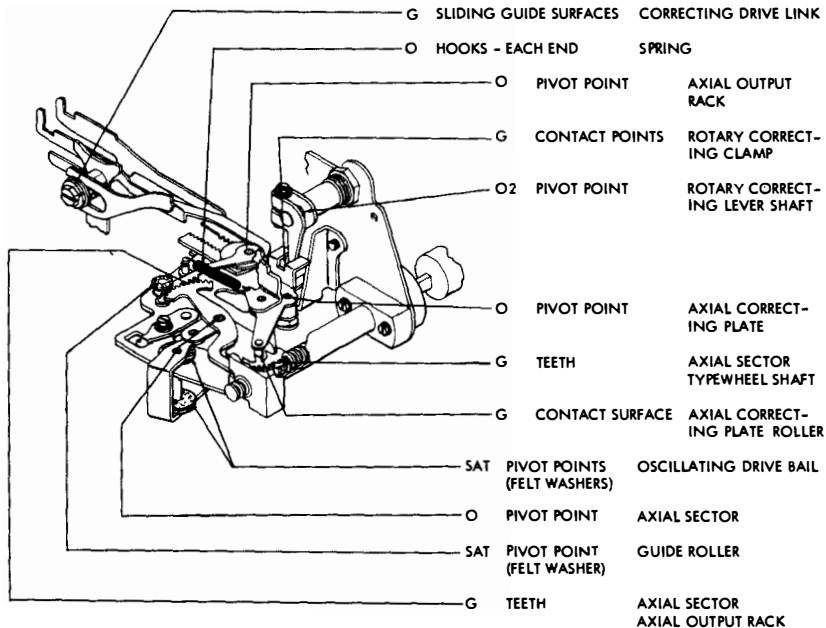

28 PERFORATOR-
TRANSMITTER-
BASE
LUBRI-
CATION

P34.530

Page 79

2.78 Axial Positioning Mechanism — Typing Perforator Only — See 2.74

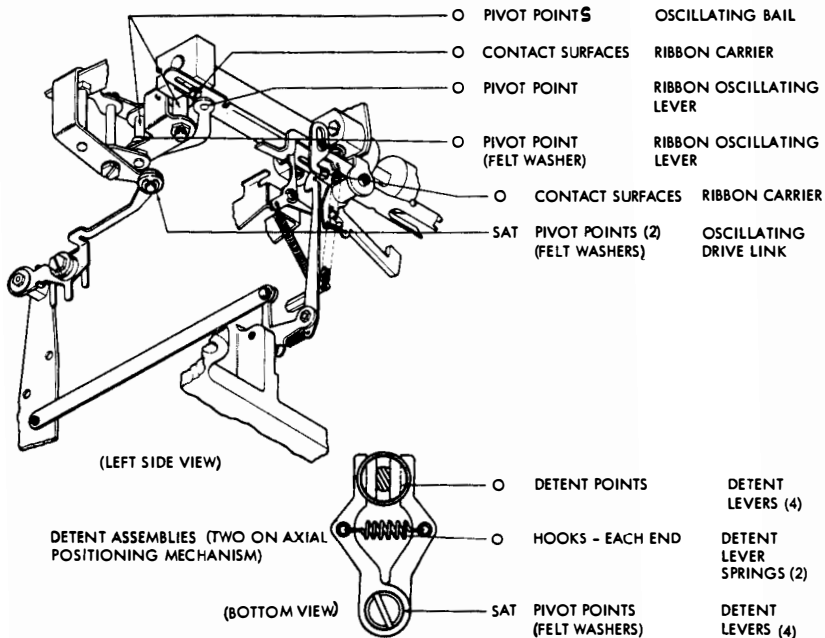

2.79 **Shaft Mechanisms — Typing Perforator Only — See 2.74**

Note: If unit has oilite or needle bearings, apply four drops of oil to the perforator cam clutch at each of its two lubrication points.

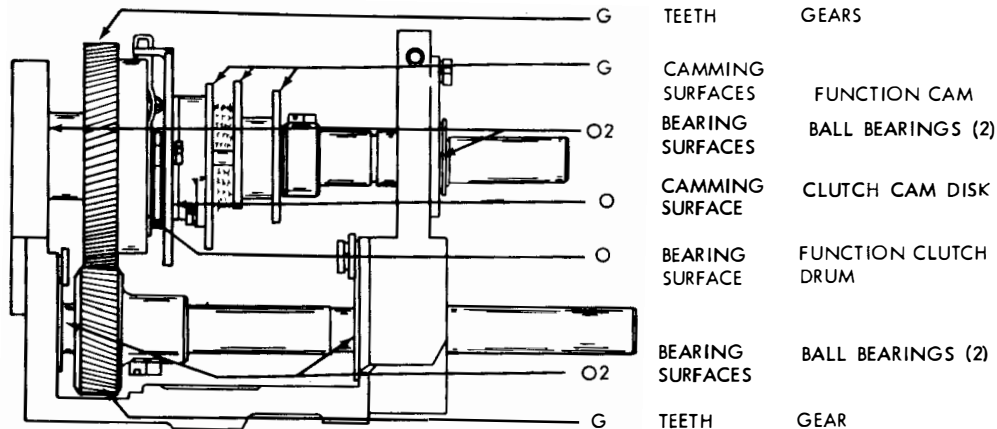

28 PERFORATOR-
TRANSMITTER-
BASE
LUBRI-
CATION

P34.530

Page 81

2.80 Printing Mechanism for Chadless Tape or Fully Perforated Tape — Left Side View — Typing Perforator Only — See 2.74

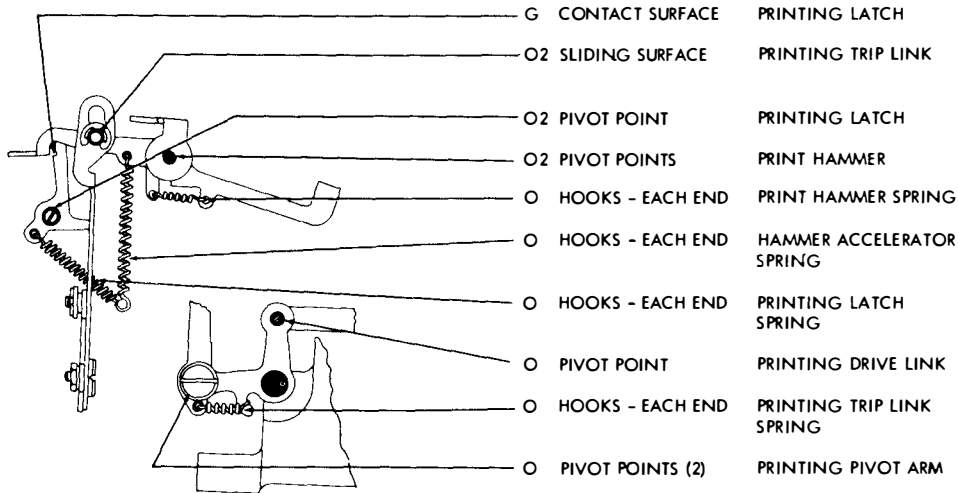

2.81 Rocker Bail Mechanism — Rear View — Typing Perforator Only — See 2.74

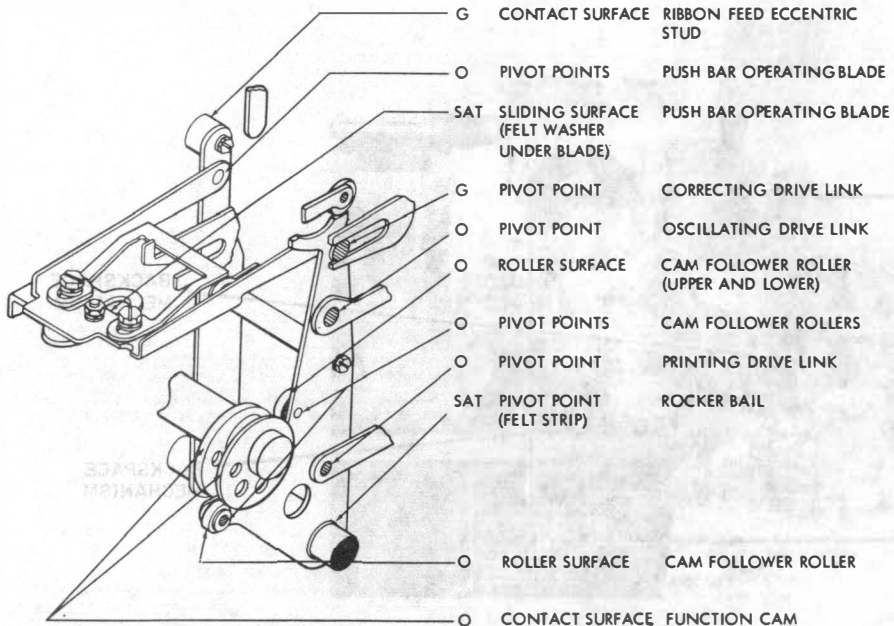

28 PERFORATOR-
TRANSMITTER-
BASE
LUBRI-
CATION

P34.530

Page 83

2.82 Typing and Nontyping Perforator Mechanism — Front View

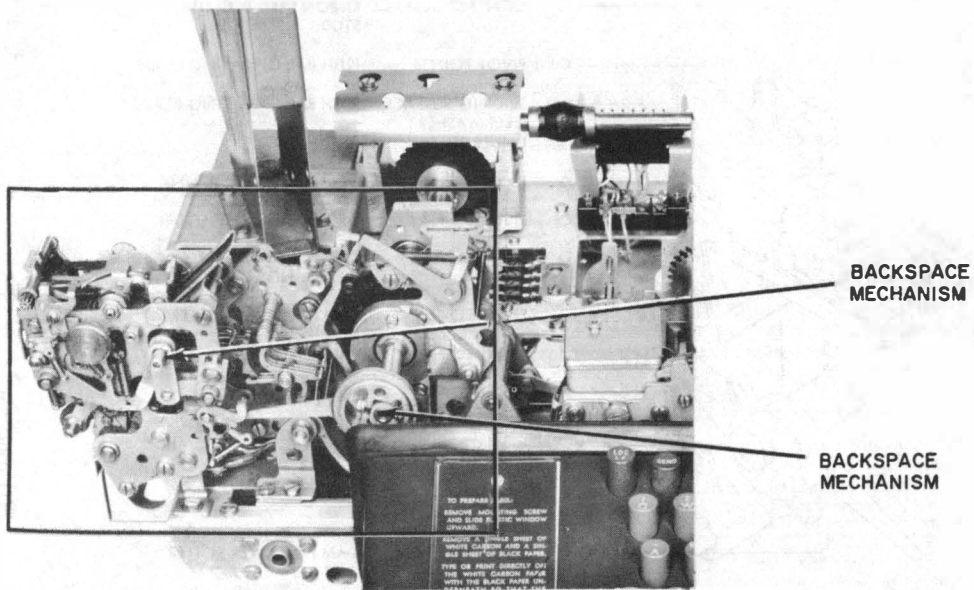

2.83 **Power-drive Backspace Mechanism for Fully Perforated Tape Only — Typing and Nontyping Perforators — See 2.82**

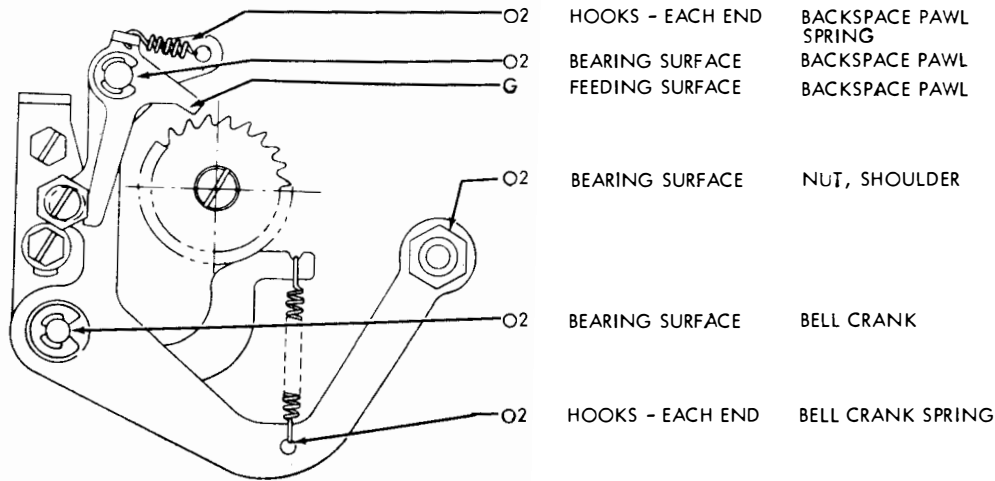

28 PERFORATOR-
TRANSMITTER-
BASE
LUBRI-
CATION

P34.530

Page 85

2.84 Power-drive Backspace Mechanism for Fully Perforated Tape Only — Typing and Non-typing Perforators — See 2.82

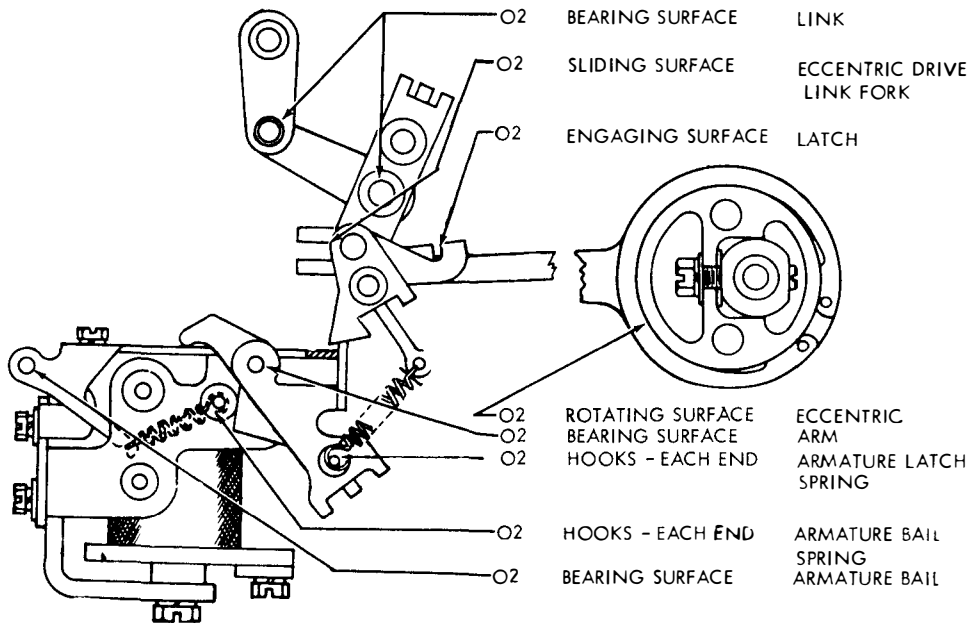

2.85 Manual Backspace Mechanism for Chadless Tape Only — Typing and Nontyping Perforators — See 2.82

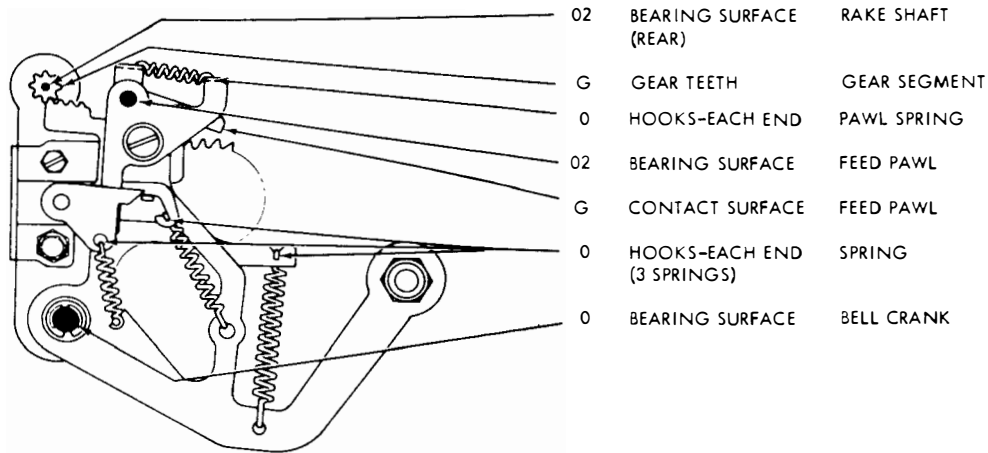

2.86 Power-drive Backspace Mechanism for Chadless Tape Only — Typing and Nontyping Perforators — See 2.82

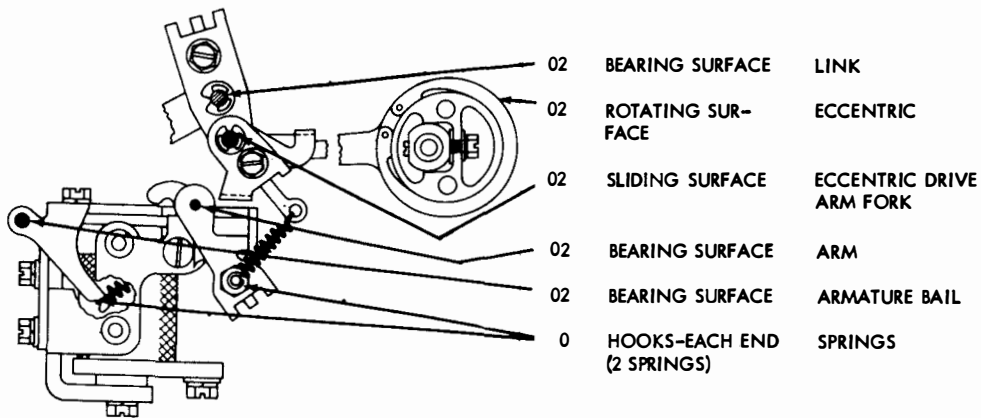

2.87 Single Auxiliary Timing Contacts Mechanism — Typing and Nontyping Perforators —
See 2.41

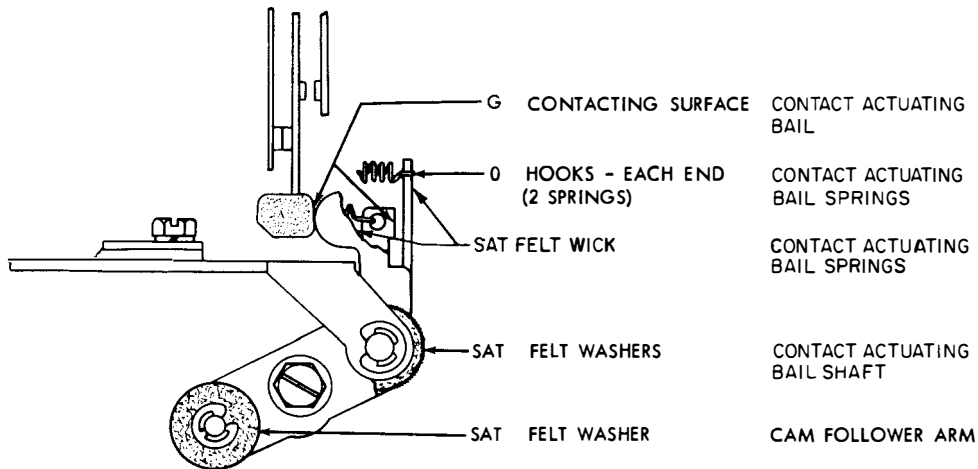

28 PERFORATOR-
TRANSMITTER-
BASE
LUBRI-
CATION

P34.530

Page 89

2.88 Unshift-on-Space Mechanism — Typing Perforator Only

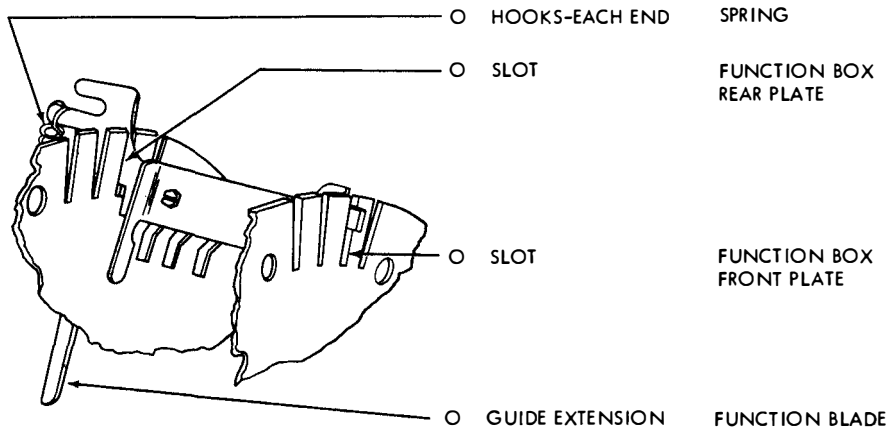

2.89 Signal Bell Contact Mechanism — Typing Perforator Only

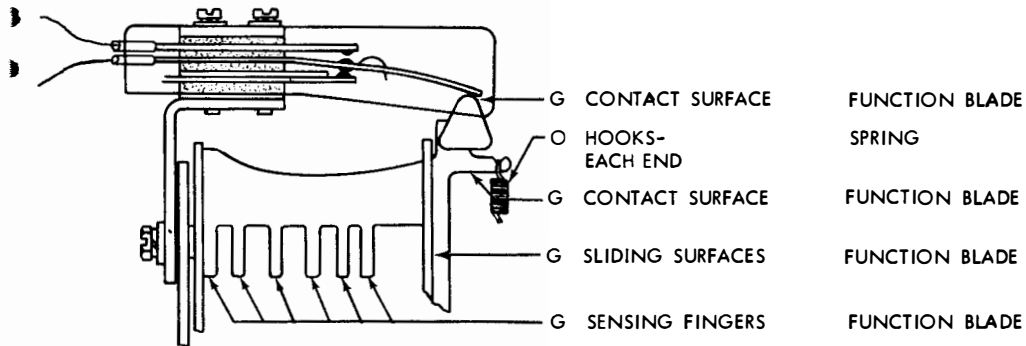

(RIGHT SIDE VIEW)

28 PERFORATOR-
 TRANSMITTER-
 BASE
 LUBRI-
 CATION

P34.530

Page 91

2.90 **Perforator Motor Pinion and Driven Gear Mechanism — Typing and Nontyping Perforators**

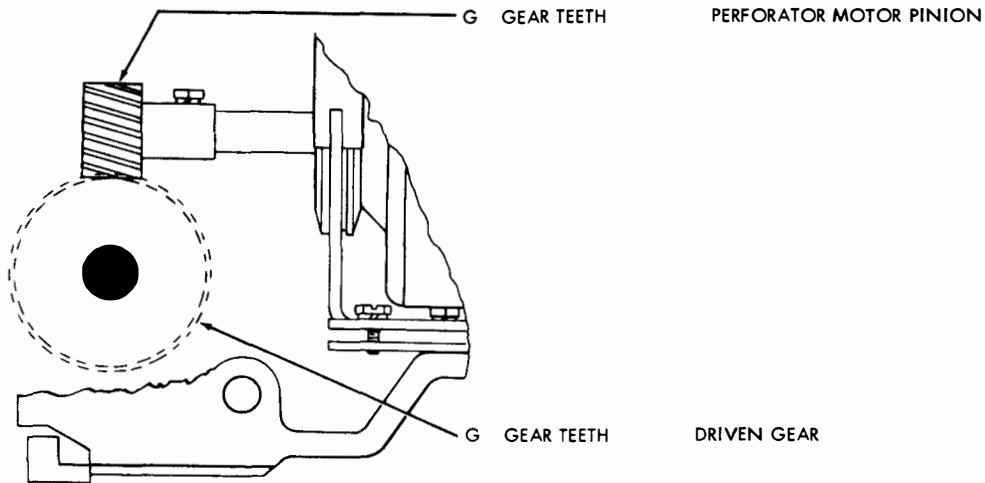

C. Typing and Nontyping Reperforators

2.91 **Single-magnet Nontyping Reperforator:** Where a nontyping reperforator of this design is part of a 28 perforator-transmitter-base, refer to the section containing the lubrication procedures for the 28 single-magnet nontyping reperforator.

2.92 **Multimagnet Nontyping Reperforator:** Where a nontyping reperforator of this design is part of a 28 perforator-transmitter-base, refer to the section containing the lubrication procedures for the 28 multimagnet nontyping reperforator.

2.93 **Single-magnet Typing Reperforator:** Where a typing reperforator is part of a 28 perforator-transmitter-base, refer to the section containing the lubrication procedures for the 28 single-magnet typing reperforator.

3. ASSOCIATED BELL SYSTEM PRACTICE

3.01 The following Bell System Practice provides additional information that may be required in connection with this section.

<u>Subject</u>	<u>Section</u>
Alphabetical Index of 28-type Equipment, Bell System Practices, and Associated 28 ASR Station Drawings	P34.001

CHANGES AUTHORIZED BY P98 SERIES BELL SYSTEM PRACTICES

<u>Par. No.</u>	<u>Mechanism</u>	<u>Includes Changes Authorized by Section</u>
2.25	Margin Indicating Mechanism	P98.995



BELL SYSTEM PRACTICES
Teletypewriter and Data Stations

ADDENDUM P34.530
Issue 2, February, 1962
AT&T Co Standard

28 PERFORATOR-TRANSMITTER-BASE LUBRICATION

1. GENERAL

1.001 This addendum supplements Section P34.530, Issue 1.

1.002 This addendum is reissued to include the lubrication information authorized for this apparatus by the P98 sections listed at the end of this addendum and to generally bring the practice up to date.

3. STANDARD FEATURES

The following changes apply to Part 3 of the section:

- (a) 3.53 and 3.54 — revised paragraph titles only
- (b) 3.54.1 and 3.54.2 — added
- (c) 3.64 — added note

3.53 **Ribbon-feed Mechanism With Spring Washer Behind Each Ribbon Spool (Typing Perforator Only)**

3.54 **Ribbon-feed Mechanism With Spring Washer Behind Each Ribbon Spool (Typing Perforator Only) (Rear View)**

3.54.1 Ribbon-feed Mechanism With Helical Spring Behind Each Ribbon Spool (Typing Perforator Only)

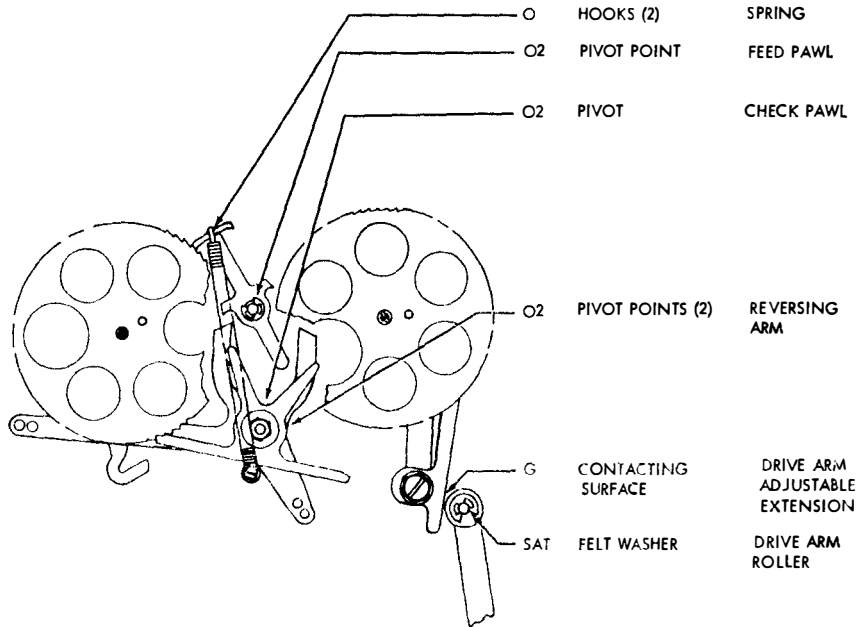

3.54.2 Ribbon-feed Mechanism With Helical Spring Behind Each Ribbon Spool (Typing Perforator Only)

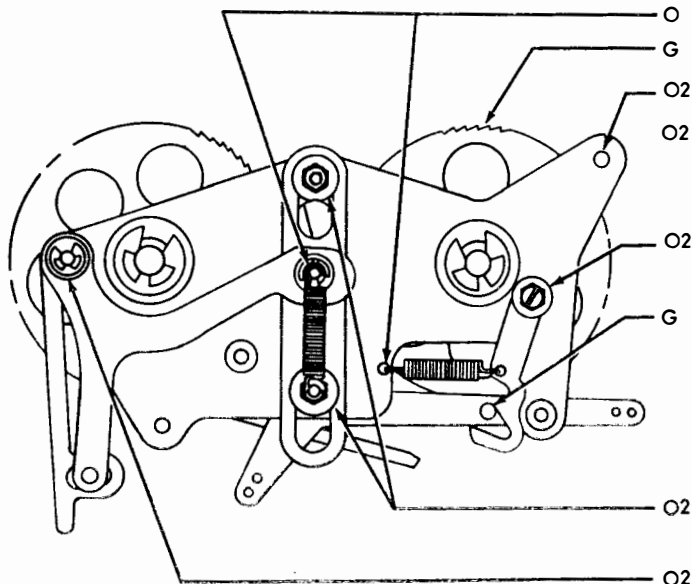

- | | | |
|----|-------------------------|---------------|
| O | HOOKS (2) | SPRINGS (2) |
| G | TEETH | RATCHET WHEEL |
| O2 | SHAFT | ROLLERS (2) |
| O2 | SHAFT, FELT WASHERS | RATCHET WHEEL |
| O2 | PIVOT | DETENT |
| G | CONTACTING SURFACES | DETENT |
| O2 | UPPER AND LOWER BUSHING | SLIDE LEVER |
| O2 | PIVOT | DRIVE ARM |



3.64 **Printing Mechanism (Typing Perforator Only)**
(Left-side View) ↗

Note: Printing mechanism with **steel print hammer**, illustrated herein, shall be lubricated as shown. Printing mechanism with **resilient print hammer**, not illustrated, shall be lubricated in same manner as that with steel print hammer, but in addition, the felt washer between the resilient print hammer accelerator and the frame shall be saturated with oil in accordance with general lubrication procedures. Where a mechanism is equipped with print suppression parts, a thin film of grease shall be applied on the print hammer stop at the point of contact with the print hammer lever. ↘

4. VARIABLE FEATURES

The following changes apply to Part 4 of the section:

- (a) 4.12, 4.13, and 4.14 — added
- (b) 4.15 — added ←

4.12 Remote-control Gear Shift Mechanism

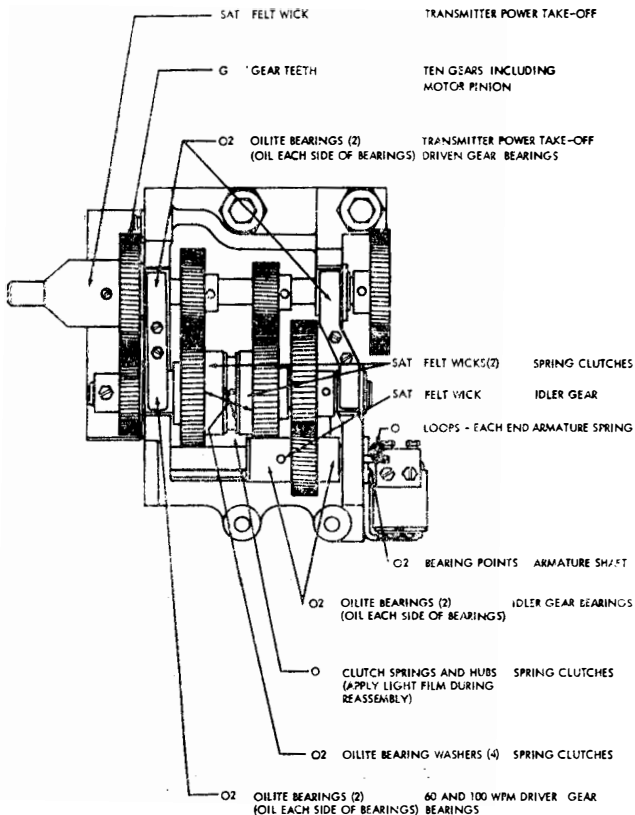

4.13 Form Feedout Mechanism

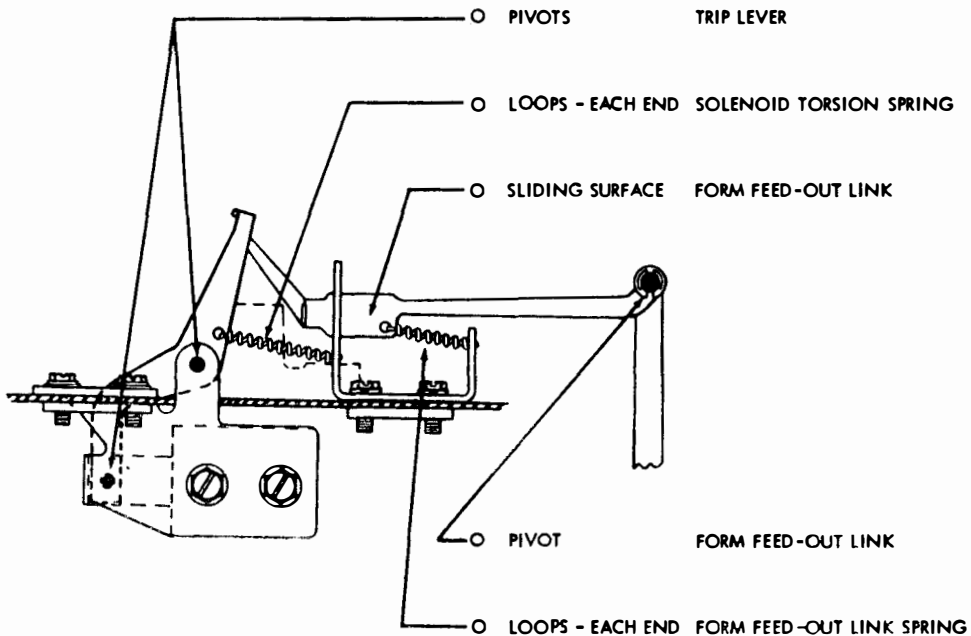

4.14 Perforator Motor Pinion and Gear

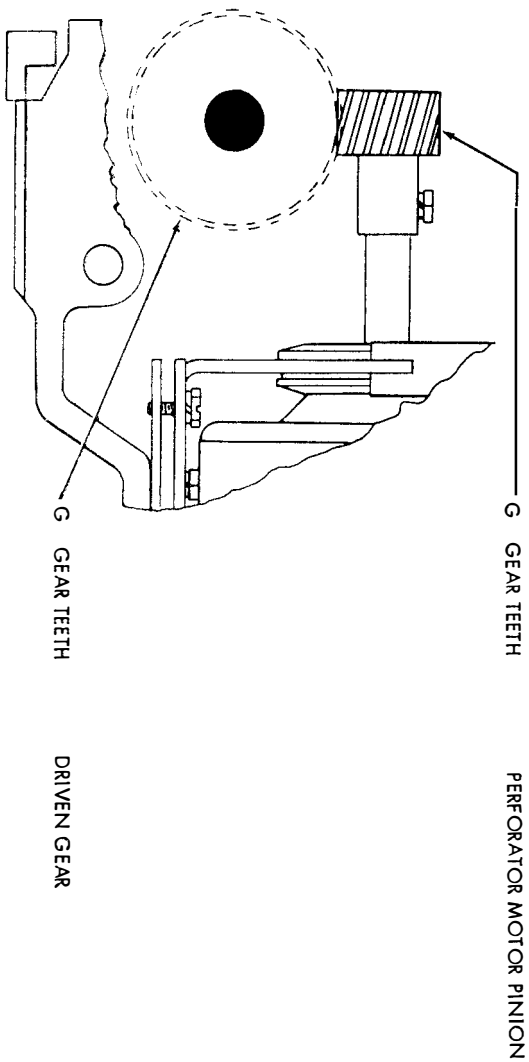

- 4.15 **Print Suppression Mechanism (Not Illustrated):** ↑
 Refer to 3.64, Note of this addendum. ↑

5. ASSOCIATED BELL SYSTEM PRACTICES

The following change applies to Part 5 of the section:

(a) 5.01 — revised

5.01 (Add the following Bell System Practice.)

<u>Subject</u>	<u>Section</u>
28 Multimagnet Nontyping Reperforator, Lubrication	P34.532

CHANGES AUTHORIZED BY P98 SERIES BELL SYSTEM PRACTICES

<u>Par. No.</u>	<u>Mechanism</u>	<u>Includes Change As Authorized By Section</u>
3.54.1 and 3.54.2	Ribbon-feed mechanism with helical springs.....	P98.817
3.64	Printing mechanism	P98.856 ↓