

BELL SYSTEM PRACTICES
Teletypewriter and Data Stations

SECTION P34.520
Issue 1, December, 1960
AT&T Co Standard

28 REPERFORATOR-TRANSMITTER UNIT LUBRICATION

CONTENTS	PAR. NO.
1. GENERAL	1.01-1.02
2. LUBRICATION DETAILS	2.01-2.11
A. Nontyping Reperforator of a 28 Reperforator- Transmitter Unit So Equipped	2.01
B. Typing Reperforator of a 28 Reperforator- Transmitter Unit So Equipped	2.02
C. Transmitter-Distributor of a 28 Reperforator- Transmitter Unit	2.03
D. Gears and Tape-winding Mechanism of a 28 Reperforator-Transmitter Unit	2.04-2.09
E. Motor of a 28 Reperforator-Transmitter Unit..	2.10
F. Variable Features of a 28 Reperforator-Trans- mitter Unit	2.11
3. ASSOCIATED BELL SYSTEM PRACTICES...	3.01

1. GENERAL

1.01 This section contains the specific lubrication procedures for the 28 reperforator-transmitter units. The material herein, together with the section entitled Teletypewriter Apparatus, Lubrication, General Information and Routines, provides the complete lubrication for the 28 reperforator-transmitter units. The lubrication symbols used herein are the same as those in the general section. However, the simple symbol O is used in this section to mean only one drop of oil. The symbol O2 is used to specify two drops of oil.

1.02 Lubrication of the 28 reperforator-transmitter unit, before it is placed in service, should be governed by the principles given in the section entitled Preparation of Teletypewriter Apparatus for Installation. After a few weeks in service, the unit should ordinarily be relubricated to make sure that all lubrication points receive lubricant. Thereafter, unless otherwise specified by the local regulations, the recommended lubrication intervals given in the individual sections for the components of the reperforator-transmitter unit may be used as a guide for use under normal operating conditions.

Note: Lubrication intervals of the motor unit should always be determined by the local regulations.

2. LUBRICATION DETAILS

A. Nontyping Reperforator of a 28 Reperforator-Transmitter Unit So Equipped

2.01 Refer to the section entitled 28 Nontyping Reperforator, Lubrication.

B. Typing Reperforator of a 28 Reperforator-Transmitter Unit So Equipped

2.02 Refer to the section entitled 28 Typing Reperforator and Base, Lubrication.

C. Transmitter-Distributor of a 28 Reperforator-Transmitter Unit

2.03 Refer to the section entitled 28C Transmitter-Distributor Unit, Lubrication.

D. Gears and Tape-winding Mechanism of a 28 Reperforator-Transmitter Unit

Note 1: Refer to 1.02.

Note 2: The following lubrication interval is suggested as a guide for use under normal operating conditions:

(a) Lubricate every 500 hours of operation or every six months, whichever occurs first.

2.04 Shift-gear-shaft Assembly

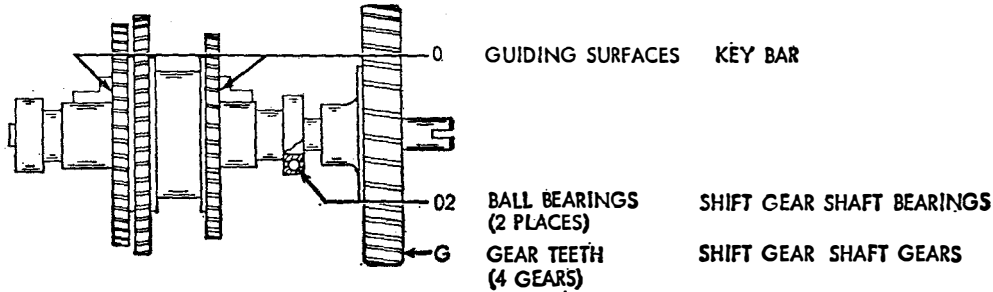

2.05 Cross-shaft Assembly

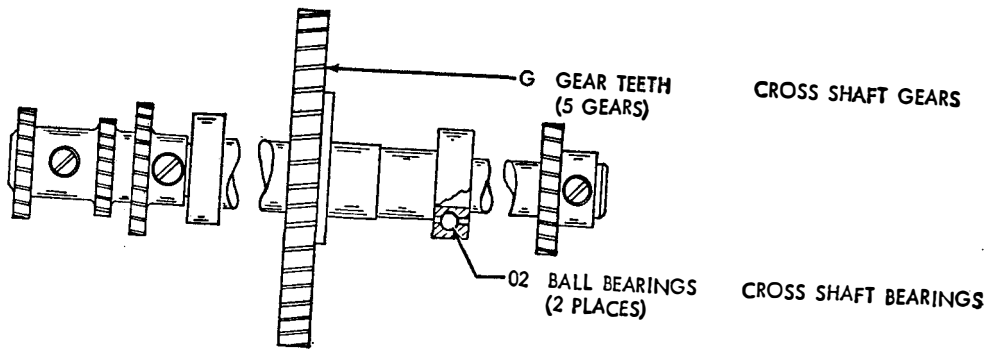

2.06 Fixed-gear Shaft

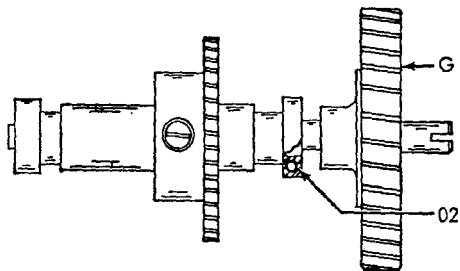

GEAR TEETH
(2 GEARS)

FIXED GEAR SHAFT GEARS

BALL BEARINGS
(2 PLACES)

FIXED GEAR SHAFT BEARINGS

28 REPERFORATOR-
TRANSMITTER
UNIT
LUBRI-
CATION

P34.520

Page 5

2.07 Gear-shift-arm Assembly

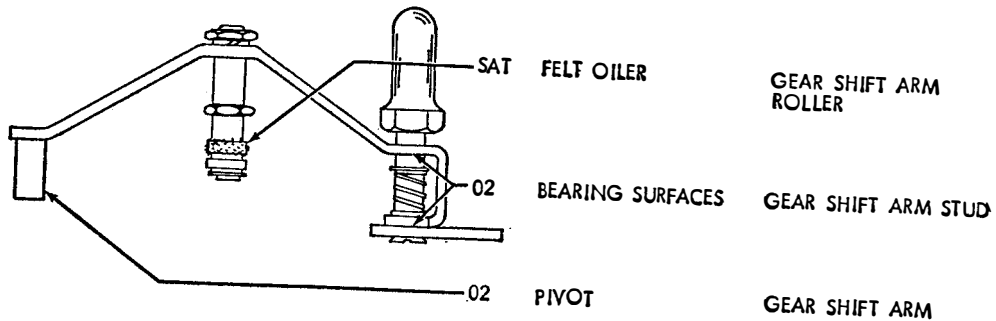

2.08 Tape-winder-drive Bracket

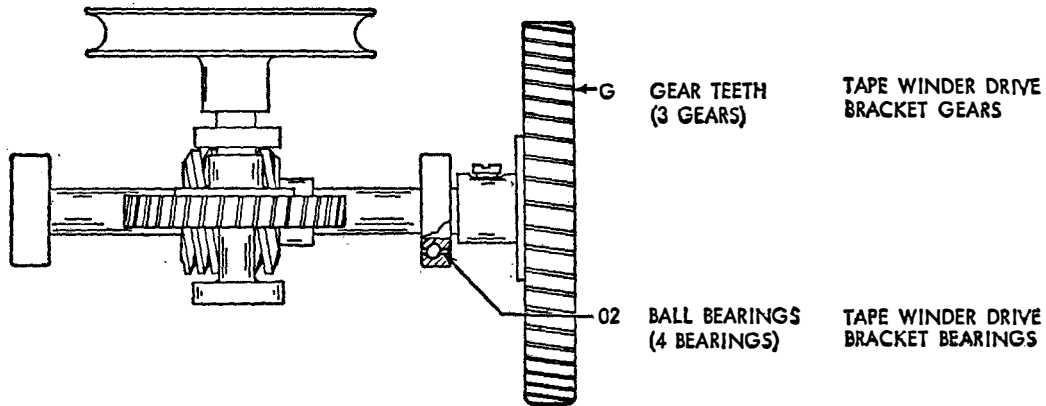

28 REPEFORATOR-
TRANSMITTER
UNIT
LUBRI-
CATION

P34.520

Page 7

2.09 Tape-bracket Rollers and Shaft

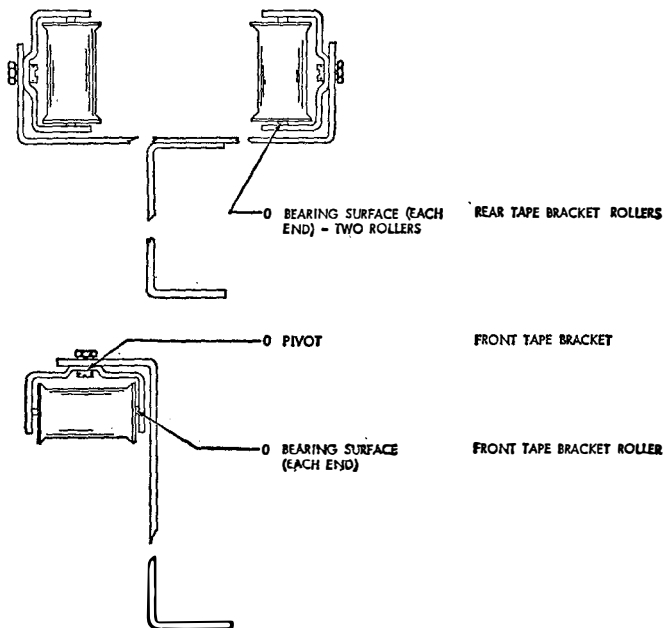

E. Motor of a 28 Reperforator-Transmitter Unit

2.10 Refer to 1.02 and to the section entitled Teletype-writer Apparatus, Lubrication, General Information and Routines.

F. Variable Features of a 28 Reperforator-Transmitter Unit

2.11 Lubrication for the variable features is as specified in the sections covering lubrication for the previously mentioned components of the 28 reperforator-transmitter unit.

3. ASSOCIATED BELL SYSTEM PRACTICES

3.01 The following Bell System Practices provide additional information that may be required in connection with this practice.

<u>Subject</u>	<u>Section</u>
Teletypewriter Apparatus, General Requirements and Adjustments	P30.012
Teletypewriter Apparatus, Lubrication, General Information and Routines	P30.011
Teletypewriter Apparatus, Preparation of Apparatus for Installation	P33.014
Teletypewriter Tools and Maintenance Supplies	P30.301
Teletypewriter Apparatus, Cleaning	P30.010
28 Teletypewriter Apparatus and Associated Equipment, Index	P34.001

(When Issued)

28 REPERFORATOR-
TRANSMITTER

P34.520

UNIT

Page 9

LUBRI-

9 Pages

CATION

