

**BELL SYSTEM PRACTICES**  
**Teletypewriter and Data Stations**

**SECTION P34.503**  
**Issue 2, November, 1963**  
**AT&TCo Standard**

**28 TELETYPEWRITER BASE**  
**(KEYBOARD SEND-RECEIVE BASE**  
**AND RECEIVING-ONLY BASE)**  
**LUBRICATION**

<b>CONTENTS</b>	<b>PARAGRAPH</b>
<b>1. GENERAL</b> .....	1.01-1.03
<b>2. LATER DESIGN KSR BASE (KEYBOARD)</b>	
Answerback Mechanism .....	2.29-2.36
Blinding (Pulsing) Contacts .....	2.37, 2.38
Breaklever .....	2.01, 2.04
Codebar .....	2.07, 2.08
Codebar Bail .....	2.20, 2.23
Codelever .....	2.01, 2.06
Codelever Universal Bail .....	2.24, 2.26
Contact Box .....	2.10, 2.13
Electrical Line Break .....	2.24, 2.25
Electrical Send-Receive Break Mechanism .....	2.40
Form Feedout .....	2.43, 2.44
Function Clutch .....	2.10, 2.15
Intermediate Gears .....	2.10, 2.19
Keyboard Lock .....	2.01, 2.05
Keylever .....	2.01, 2.03
Local Carriage Return .....	2.07, 2.09
Local Line Feed .....	2.10, 2.18
Lockbar Latch .....	2.24, 2.27
Locking Bail .....	2.20, 2.21
Margin Indicator .....	2.10, 2.16
Nonrepeat Lever .....	2.10, 2.11
Paper Feedout .....	2.24, 2.28
Remote Control Gear Shift .....	2.41, 2.42
Repeat-space Mechanism .....	2.37, 2.39
Shaft .....	2.10, 2.17

CONTENTS (Contd)	PARAGRAPH
Spacebar .....	2.01, 2.02
Transfer Bail .....	2.10, 2.14
Transfer Lever .....	2.10, 2.12
Universal Bail Latchlever .....	2.20, 2.22
Universal Keyboard Switch .....	2.48
Variable Speed Drive Mechanism .....	2.45-2.47
<b>3. EARLIER DESIGN KSR BASE (KEYBOARD)</b>	
Answerback .....	3.26-3.28
Codebar .....	3.06, 3.09
Codebar Bail and Eccentric Follower .....	3.06, 3.11
Codelever .....	3.01, 3.02
Codelever Bail .....	3.06, 3.12
Contact Box .....	3.06, 3.08
Intermediate Gears .....	3.13, 3.14
Intermediate Lever (Signal Generator) .....	3.16, 3.20
Keyboard Lock .....	3.01, 3.05
Keyboard Selector .....	3.06, 3.10
Local Carriage Return .....	3.01, 3.03
Local Line Feed .....	3.01, 3.04
Margin Indicator .....	3.06, 3.07
Paper Feedout .....	3.24, 3.25
Repeat-space Mechanism .....	3.21, 3.23
Shaft .....	3.13, 3.15
Signal Generator and Clutch .....	3.16, 3.18-3.20
Signal Line Break Mechanism .....	3.21, 3.22
Time Delay Mechanism .....	3.16, 3.17
<b>4. RECEIVING-ONLY (RO) BASE</b>	
Signal Line Break Mechanism .....	4.01, 4.02
<b>5. ASSOCIATED BELL SYSTEM PRACTICES ...</b>	
	5.01
<b>1. GENERAL</b>	

1.01 This section provides the specific lubrication routines for the maintenance of the 28 teletypewriter base (KSR base and RO base) including variable and auxiliary features. Teletypewriter bases of the KSR type are also referred to as **keyboards**. This material, together with that contained in the section entitled Teletypewriter Apparatus, Lubrication, General Information and Routines, gives the complete information for lubricating the unit. The lubrication symbols used herein are the same as those in the general section. However, the symbol O is used in this section to mean only one drop of oil. The symbol O2 is used to specify 2 drops of oil.

1.02 The section is reissued to:

- (a) Add a more detailed table of contents.
- (b) Improve the locator photographs by labeling the identifying arrows with the names of the mechanisms instead of paragraph numbers.
- (c) Revise 2.16 as authorized by Section P98.995.
- (d) Add six new locator photographs (2.29, 2.37, 2.41, 2.43, 2.45, and 4.01) and seven line drawings (2.11, 2.40, 2.46, 2.47, 3.26, 3.27, and 3.28).

Marginal arrows are not used to indicate changes.

1.03 The keyboard or base should be lubricated before being placed in service as specified in the section entitled Preparation of Teletypewriter Apparatus for Installation. After a few weeks in service, it should ordinarily be relubricated to make certain that all the specified points have received lubricant. Thereafter, because of the varying conditions at each station, the keyboard or base should be lubricated as often as specified by the local instructions. The following lubrication intervals are suggested as a guide for use under normal operating conditions.

#### OPERATING SPEEDS

(Words per Minute)

60  
75  
100

#### LUBRICATING INTERVALS

(Whichever occurs first)

3000 hours or 1 year  
2400 hours or 9 months  
1500 hours or 6 months

28 TELETYPEWRITER

P34.503

Page 3

BASE  
LUBRI-  
CATION

## 2. LATER DESIGN KSR BASE (KEYBOARD)

### 2.01 Spacebar, Keylever, Breaklever, Keyboard Lock, and Codelever Mechanisms

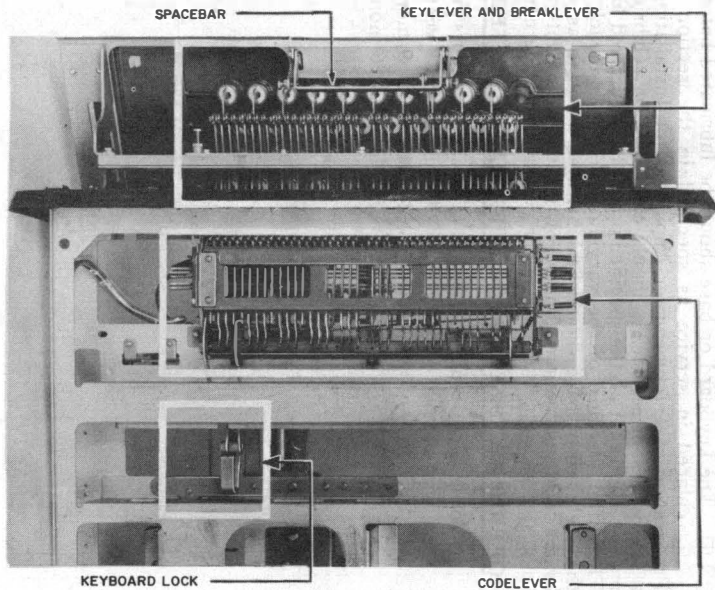

2.02 Spacebar



2.03 Keylever



28 TELETYPEWRITER



P34.503

Page 5

BASE  
LUBRI-  
CATION

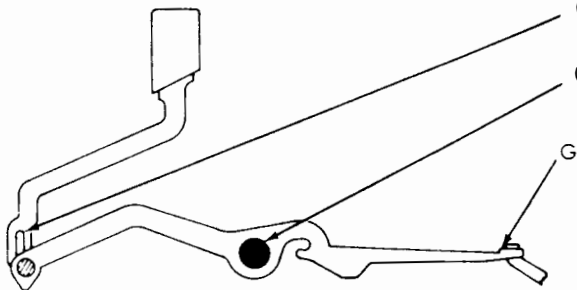

## 2.04 Breaklever

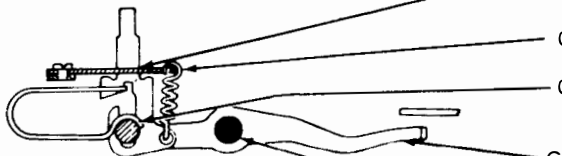

- |   |                       |                   |   |
|---|-----------------------|-------------------|---|
| 0 | ENGAGING SUR-<br>FACE | BREAK KEYLEVER    |  |
| 0 | BEARING SURFACE       | FUNCTION<br>LEVER |  |
| G | CONTACT SUR-<br>FACE  | BREAK LEVER       |   |

## 2.05 Keyboard Lock



- |   |                       |                                 |   |
|---|-----------------------|---------------------------------|---|
| 0 | GUIDE SLOT            | KEYBOARD LOCK<br>PLUNGER        |   |
| 0 | HOOKS-EACH END        | SPRING                          |   |
| 0 | BEARING SURFACE       | KEYBOARD LOCK<br>LEVER          |  |
| G | ENGAGING SUR-<br>FACE | KEYBOARD LOCK<br>FUNCTION LEVER |  |
| 0 | BEARING SURFACE       | FUNCTION BAIL                   |   |

2.06 Codelever

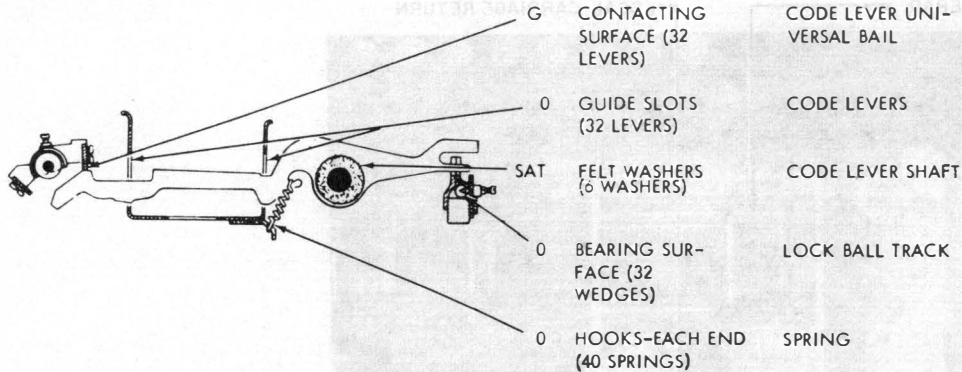

## 2.07 Codebar and Local Carriage Return Mechanisms

CODEBAR

LOCAL CARRIAGE RETURN

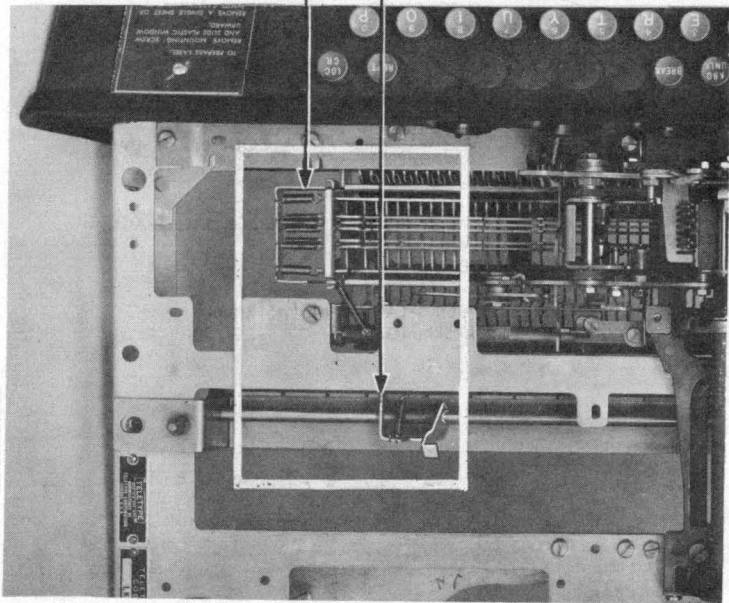



## 2.08 Codebar

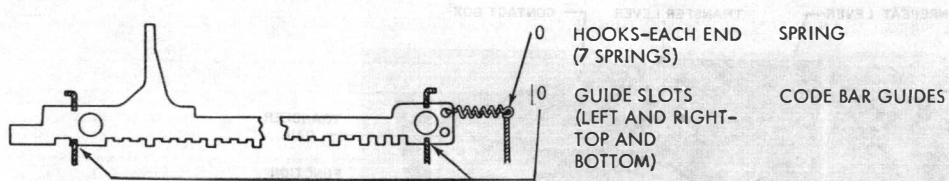

## 2.09 Local Carriage Return

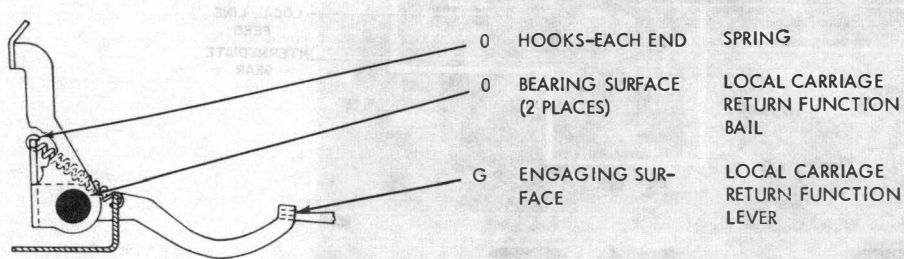

## 2.10 Nonrepeat Lever, Transfer Lever, Contact Box, Transfer Bail, Function Clutch, Margin Indicator, Shaft, Local Line Feed, and Intermediate Gear

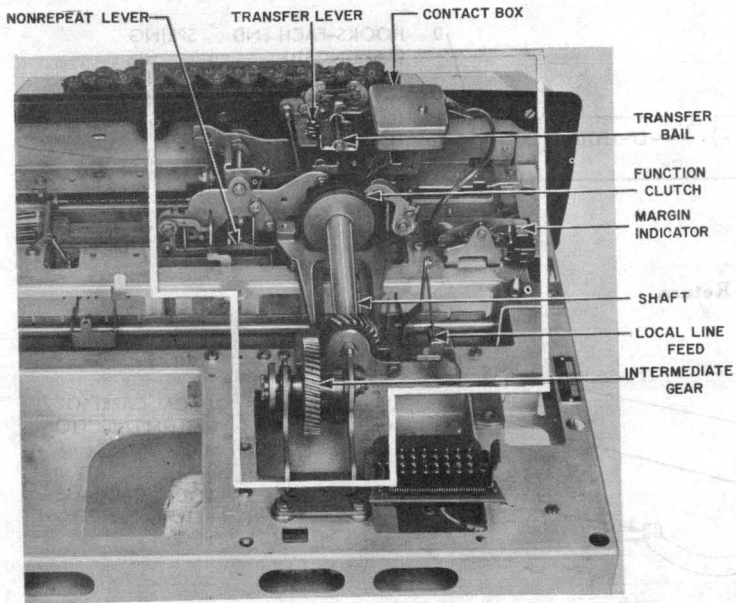

### 2.11 Nonrepeat Lever (Later Design)

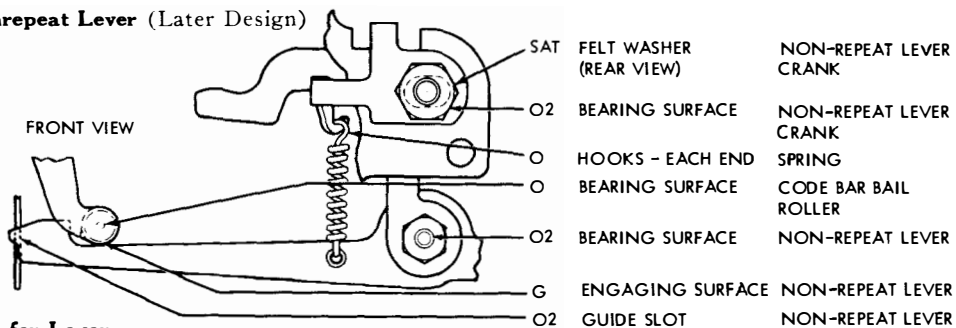

### 2.12 Transfer Lever

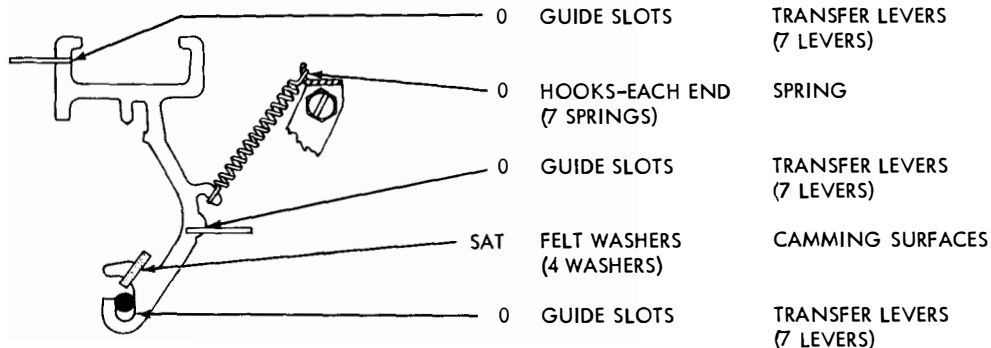

### 2.13 Contact Box

**Note:** Grease sparingly. Keep contacts free of oil or grease.

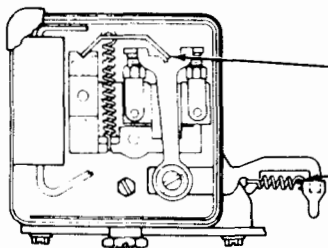

G ENGAGING SUR- CONTACT TOGGLE  
FACE

O HOOKS-EACH END SPRING

DISASSEMBLY: REMOVE NUT AND LOCK WASH-  
ER SECURING CONTACT BOX  
COVER AND REMOVE COVER.

### 2.14 Transfer Bail

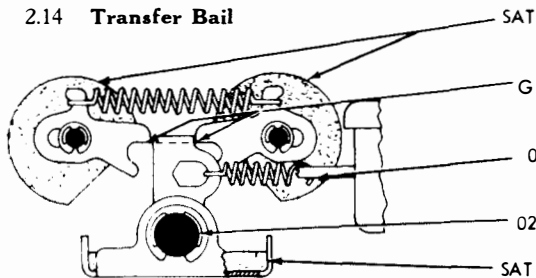

SAT FELT WASHERS LATCHES  
(2 WASHERS)

G ENGAGING SUR- TRANSFER BAIL  
FACE

O HOOKS-EACH END SPRING  
(2 SPRINGS)

O2 BEARING SURFACE TRANSFER BAIL

SAT OIL WICK TRANSFER BAIL

## 2.15 Function Clutch

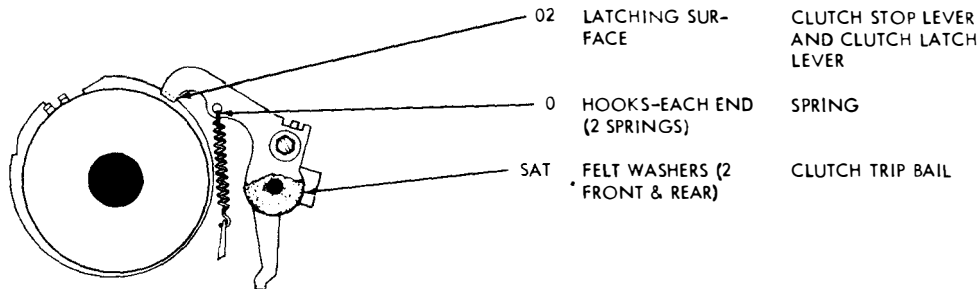

## 2.16 Margin Indicator (Front View)

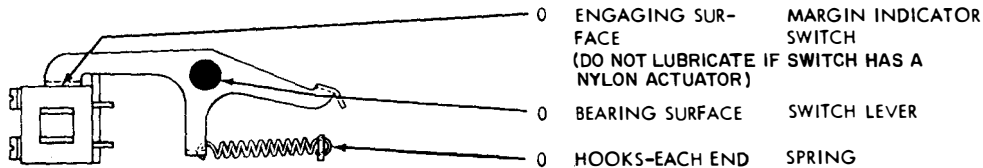

## 2.17 Shaft

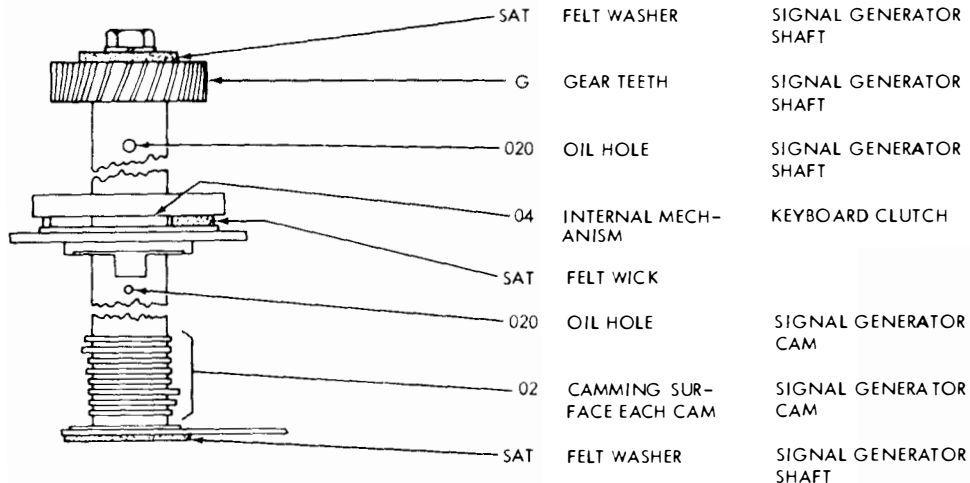

2.18 **Local Line Feed**

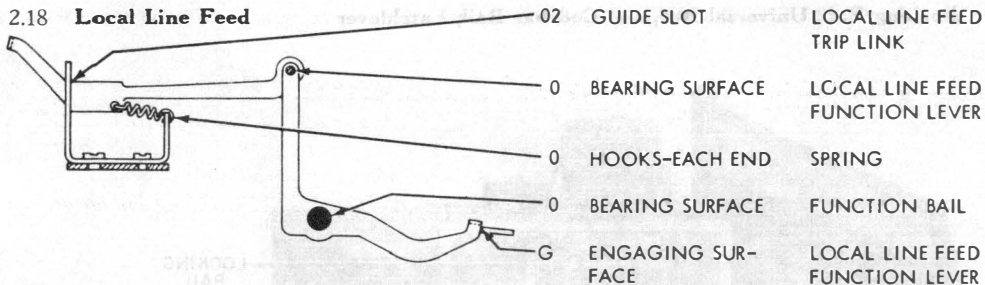

2.19 **Intermediate Gears** (For motor, see section entitled 28 Motor Unit, Lubrication)

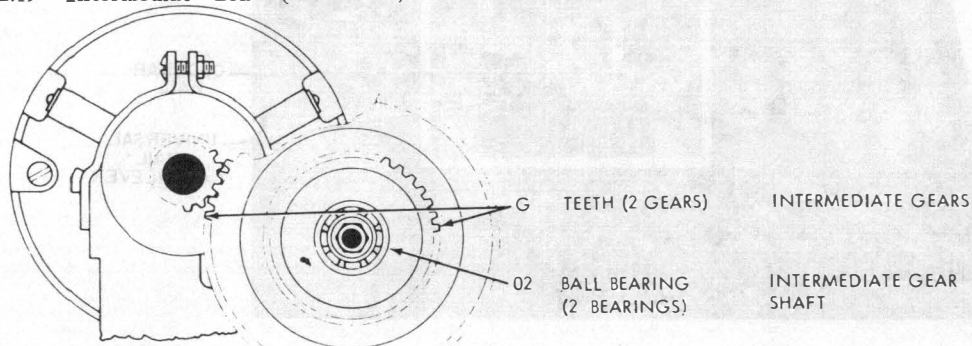

## 2.20 Locking Bail, Universal Bail, and Codebar Bail, Latchlever

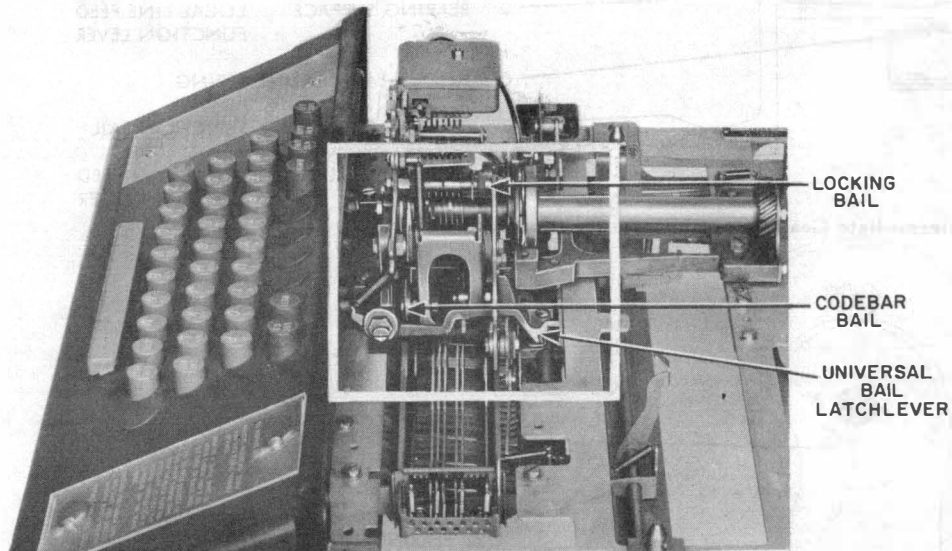



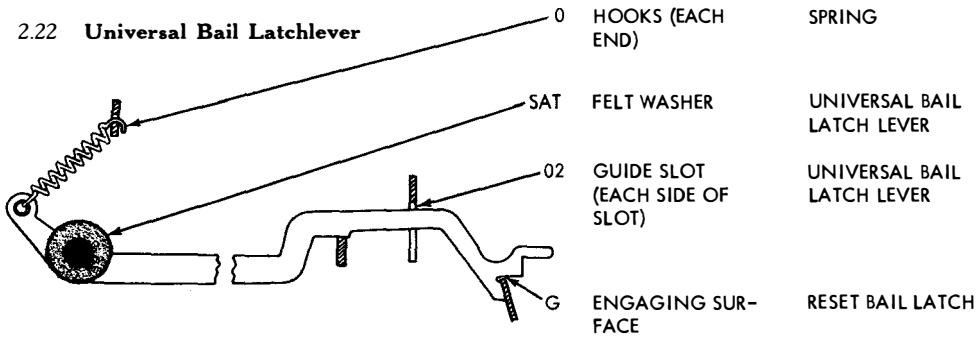
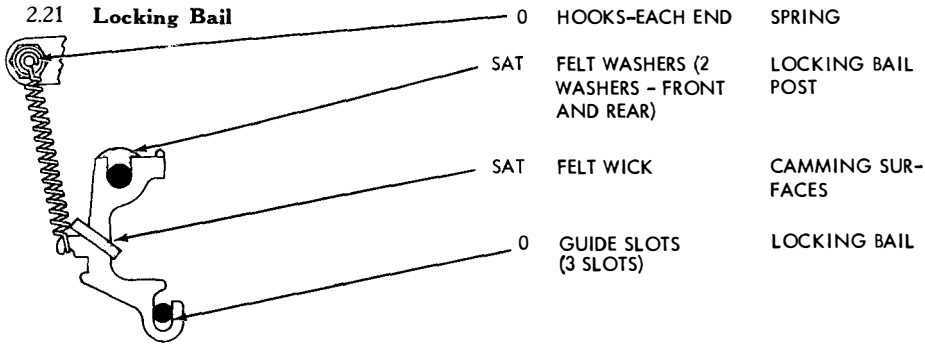

## 2.23 Codebar Bail

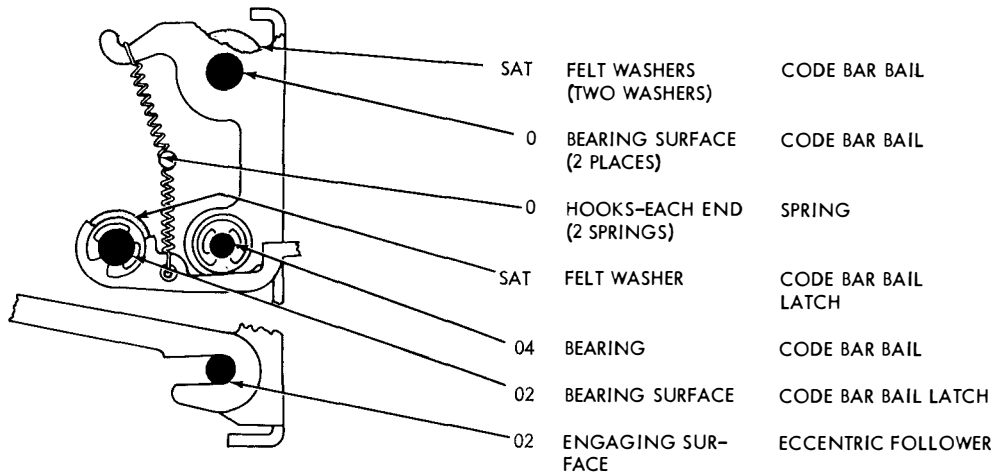

## 2.24 Electrical Line Break, Codelever Universal Bail, Lockbar Latch and Paper Feedout Mechanisms

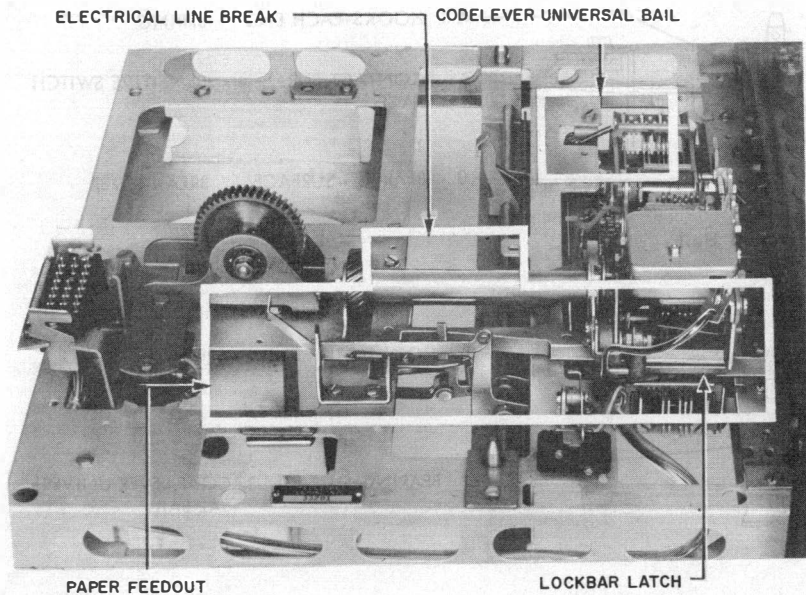

## 2.25 Electrical Line Break

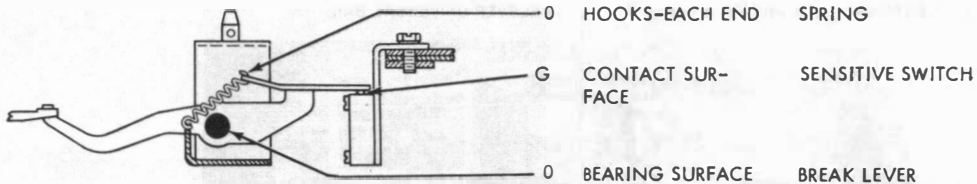

## 2.26 Codelever Universal Bail

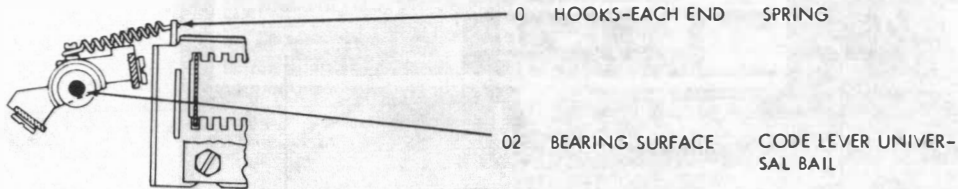

2.27 Lockbar Latch

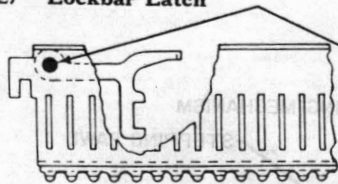

O BEARING SURFACE LOCK BAR LATCH

2.28 Paper Feedout

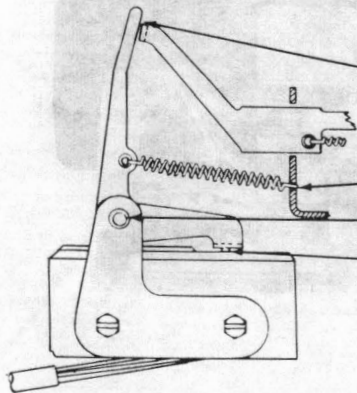

G ENGAGING SURFACE LOCAL LINE FEED TRIP LINK  
 O HOOKS-EACH END SPRING  
 O2 BEARING SURFACE LEVER  
 G ENGAGING SURFACE MAGNETIC BLOWOUT SWITCH

## 2.29 Answerback Mechanism

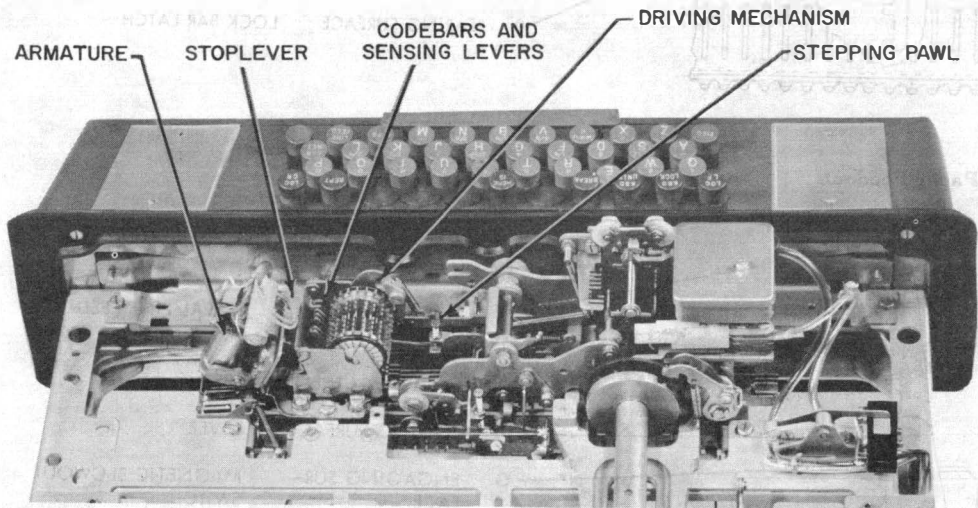

2.30 Answerback: Armature

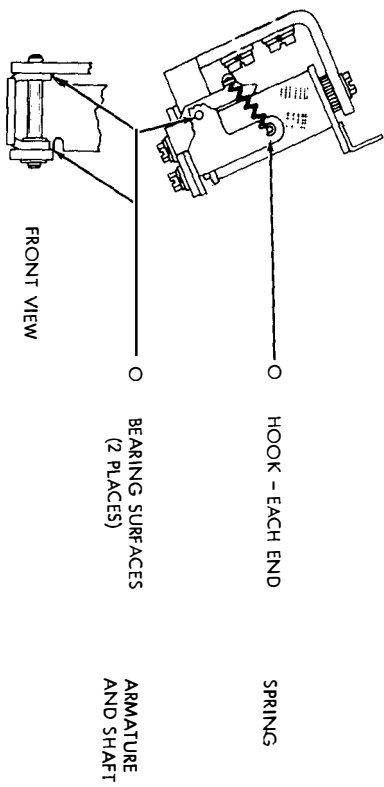

28 TELETYPEWRITER

P34.503

Page 23

BASE  
LUBRI-  
CATION

### 2.31 Answerback: Stoplever

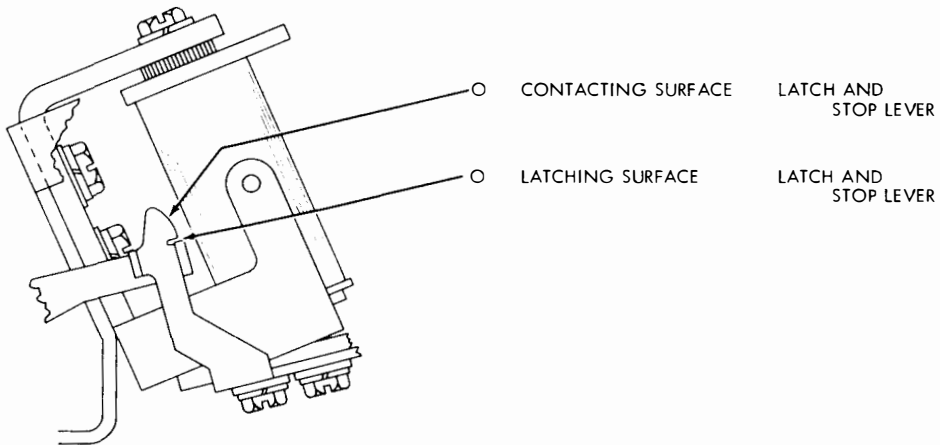



2.32 Answerback: Stoplever (Contd)

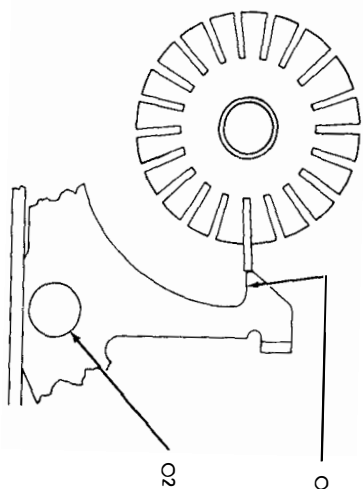

O

CAMMING SURFACE

STOP LEVER

O2

BEARING SURFACE  
(2 PLACES)

STOP LEVER AND  
LEVER PIVOT

28 TELETYPEWRITER

P34.503

Page 25

BASE  
LUBRI-  
CATION

### 2.33 Answerback: Sensing Levers

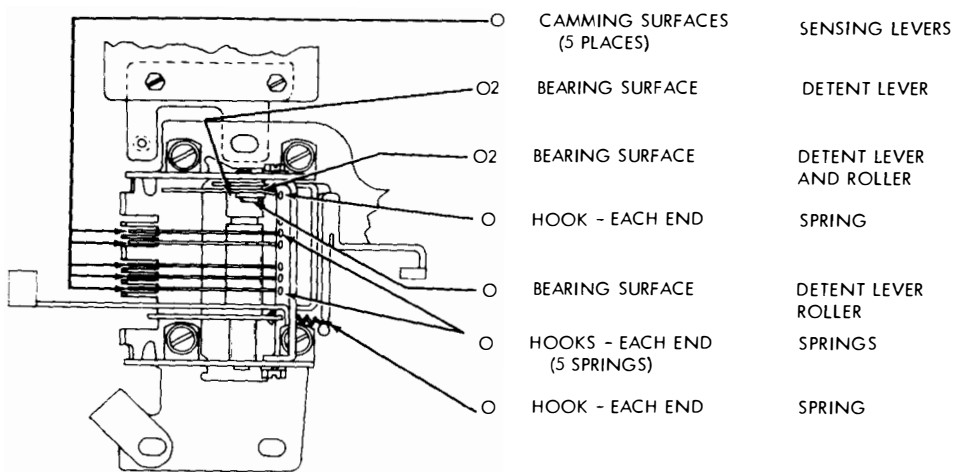

### 2.34 Answerback: Codebars and Sensing Levers

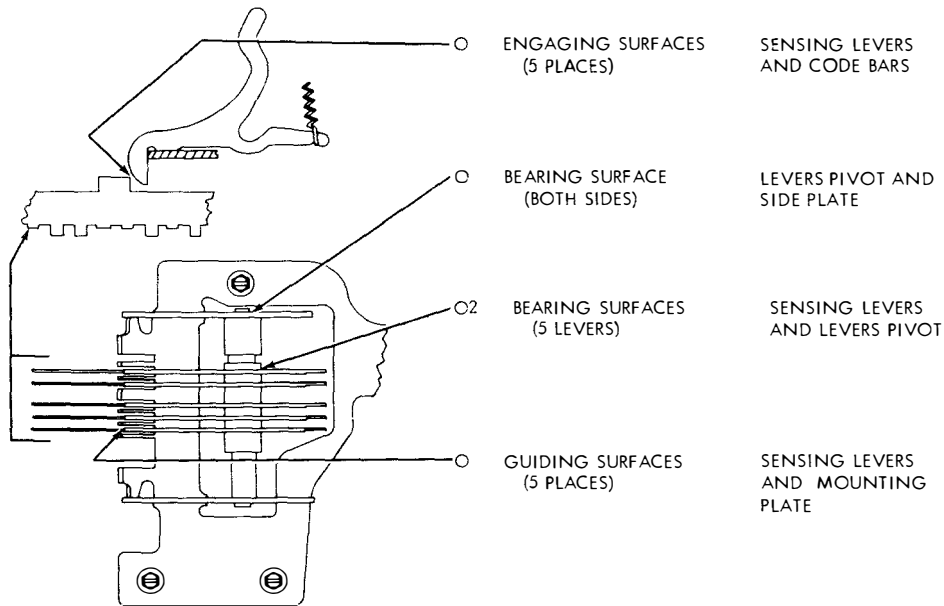

### 2.35 Answerback: Driving Mechanism

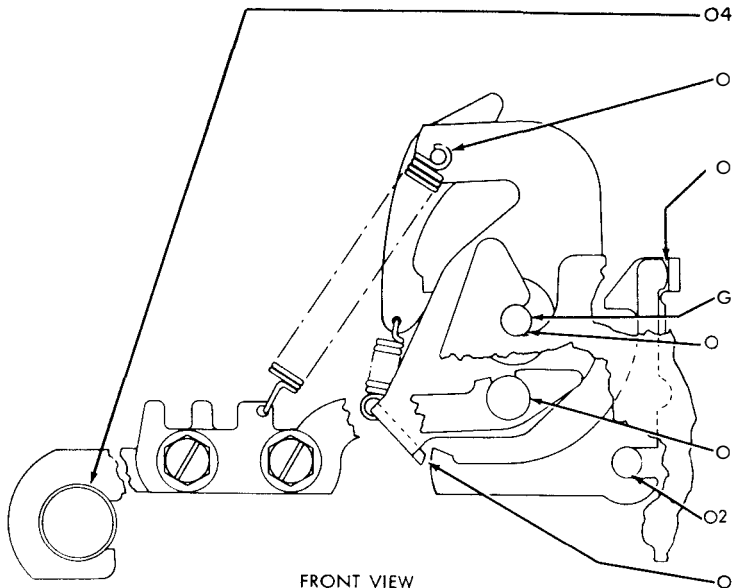

FRONT VIEW

- O04 BEARING SURFACE ECCENTRIC STUD AND DRIVE LINK
- O HOOK - EACH END SPRING
- O ENGAGING SURFACE BLOCKING LEVER AND STOP LEVER
- G SHAFT DRIVE PLATE
- O BEARING SURFACE (2 PLATES) DRIVE PLATE SHAFT AND SIDE PLATE
- O ENGAGING SURFACE DRIVE LINK AND STUD
- O02 BEARING SURFACE BLOCKING LEVER AND LEVER PIVOT
- O ENGAGING SURFACE BLOCKING LEVER AND EXTENSION

2.36 Answerback: Stepping Pawl

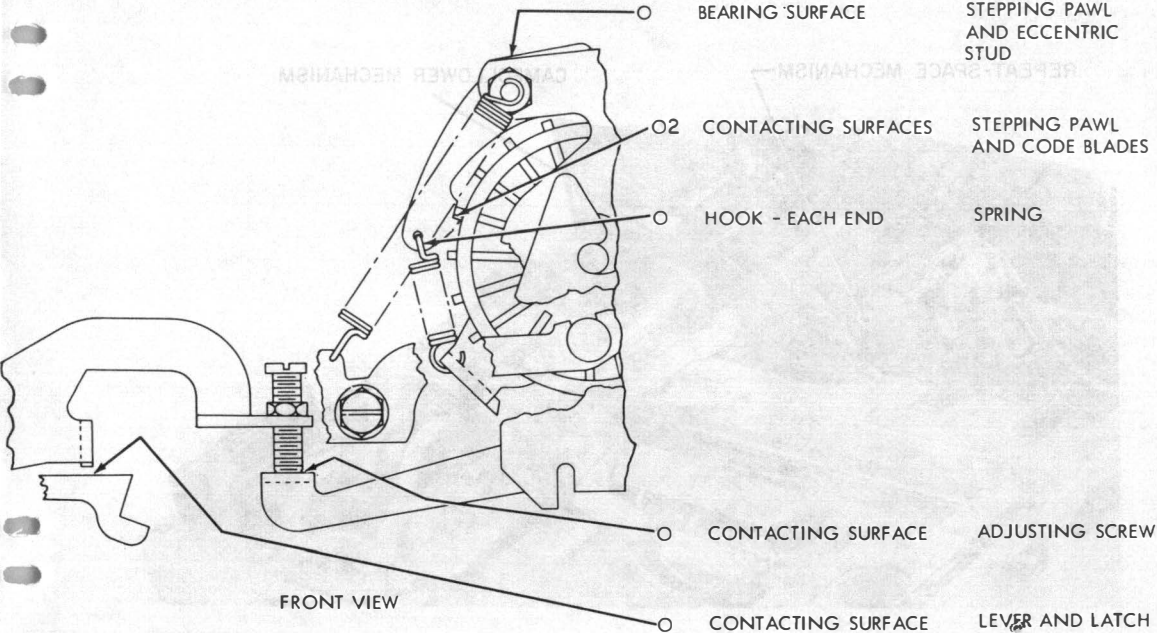

28 TELETYPEWRITER  
BASE  
LUBRI-  
CATION

P34.503

Page 29

## 2.37 Blinding (Pulsing) Contacts and Repeat-space Mechanism

REPEAT-SPACE MECHANISM

CAMFOLLOWER MECHANISM

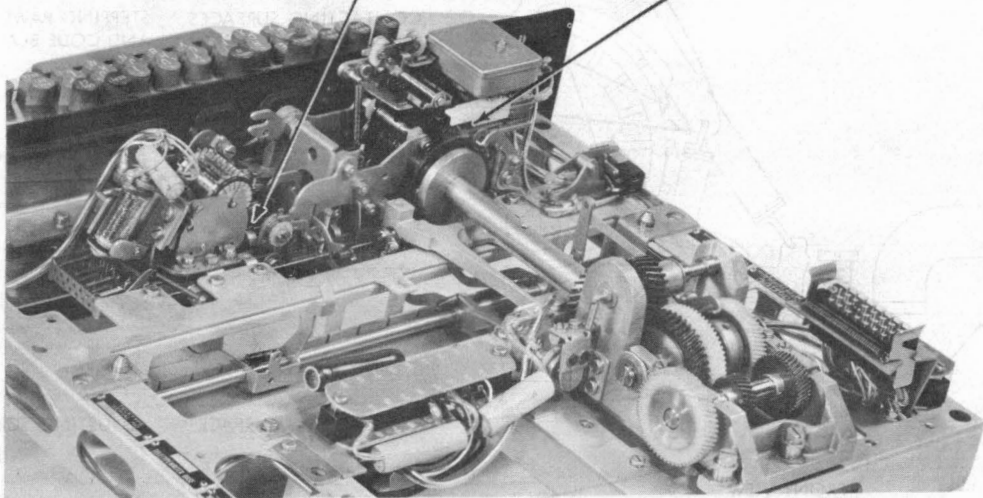

### 2.38 Blinding (Pulsing) Contacts — Camfollower Mechanism

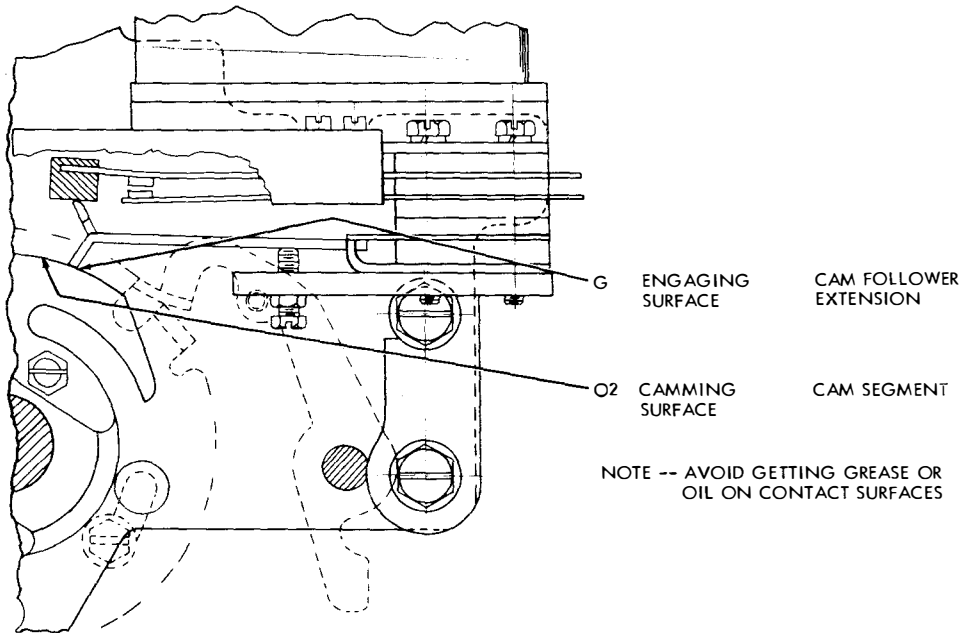

### 2.39 Repeat-space Mechanism

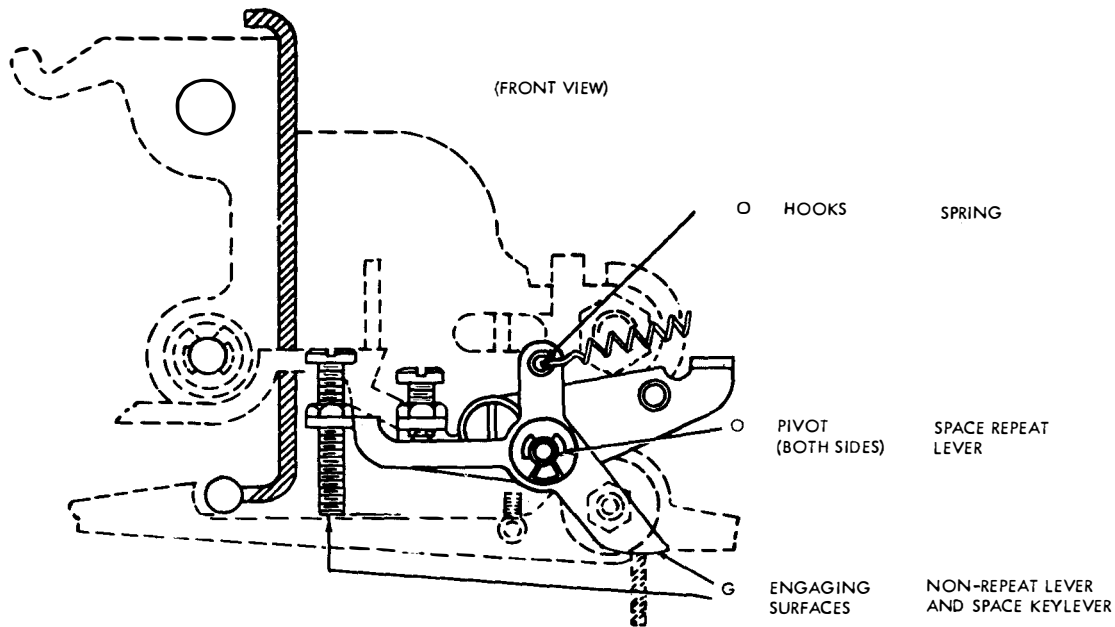



2.40 Electrical Send-Receive Break Mechanism (Not Shown on a Locator Photograph)

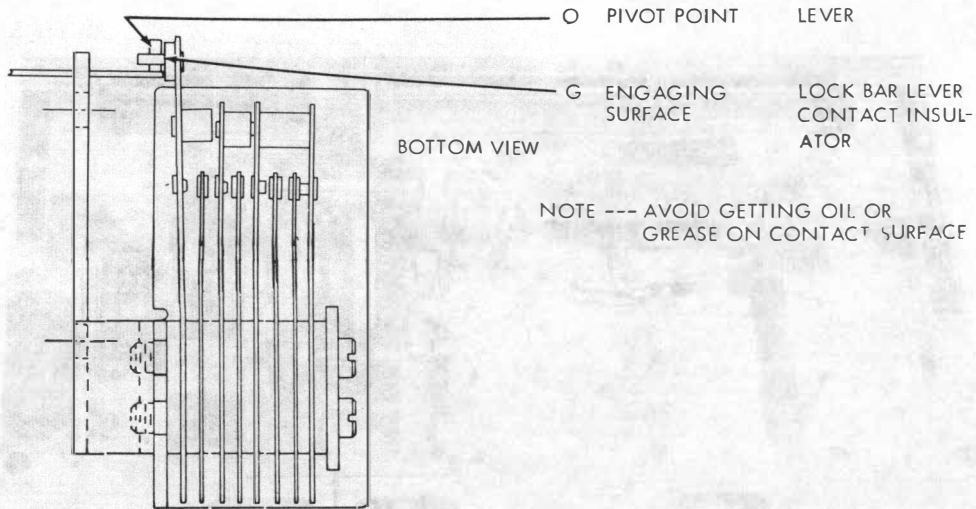

## 2.41 Remote Control Gear Shift (Rear View)

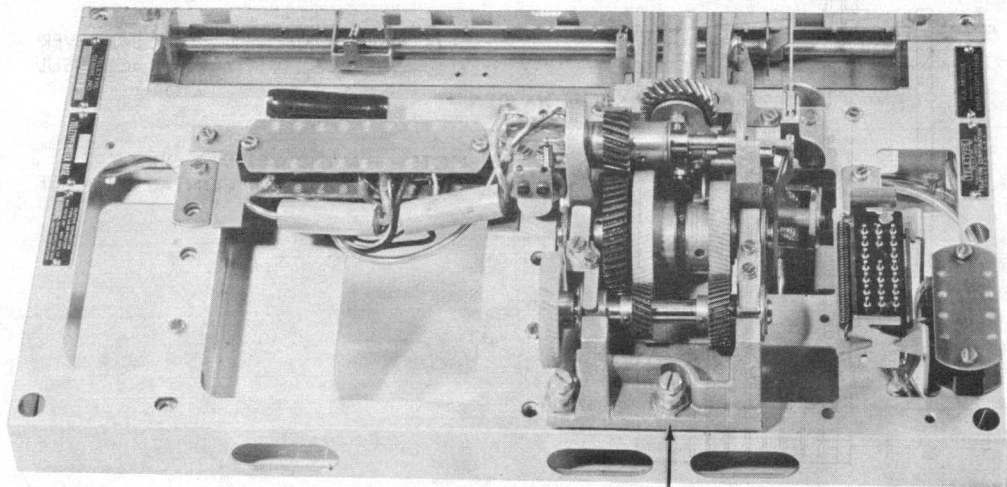

REMOTE CONTROL GEAR SHIFT

## 2.42 Remote Control Gear Shift (Top Front View)

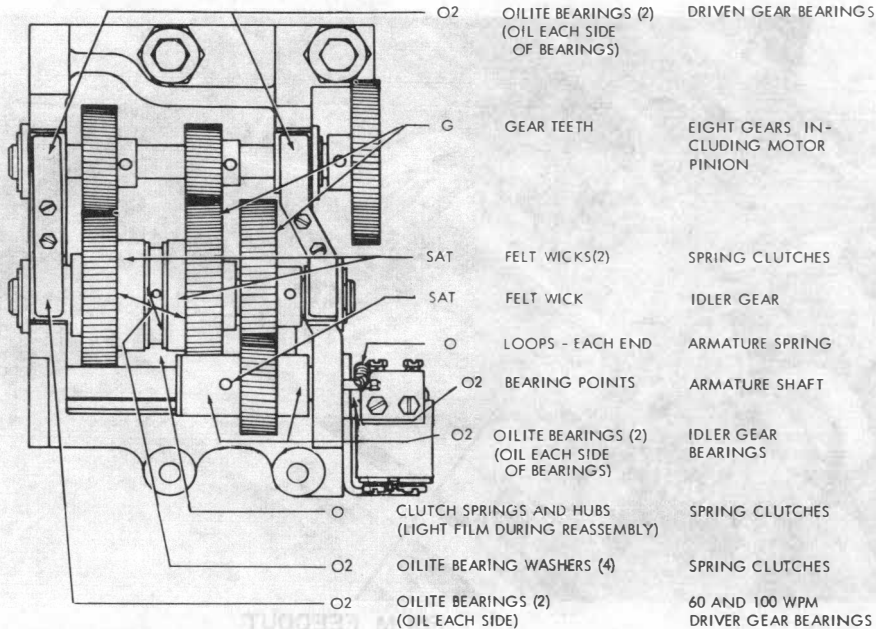

28 TELETYPEWRITER  
BASE  
LUBRI-  
CATION

P34.503

Page 35

034203

OPTIONAL  
FORM FEED  
UNIT

OR TELETYPE UNIT

2.43 Form Feedout

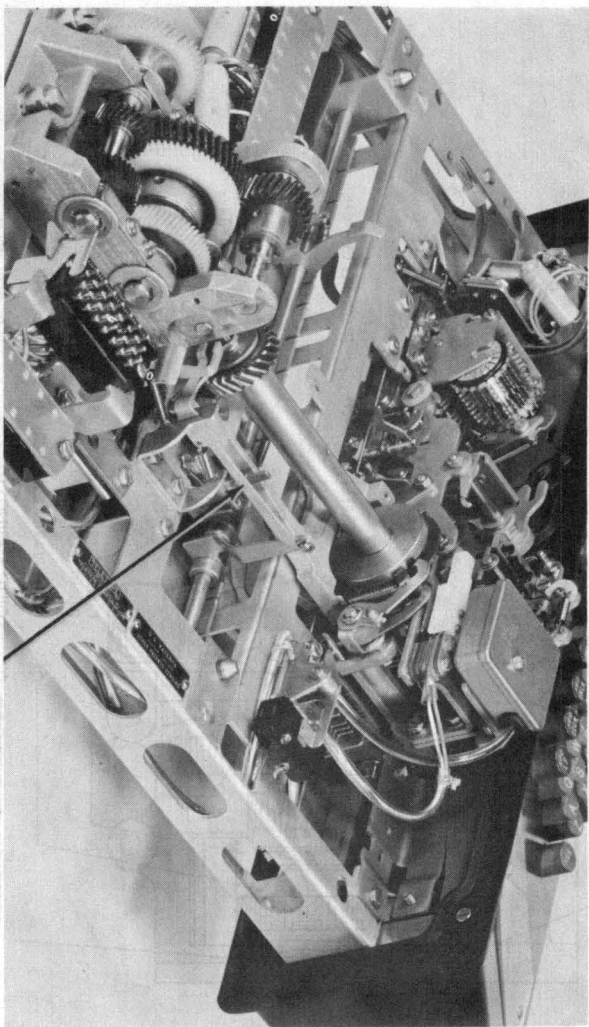

FORM FEEDOUT

(View from front) (Fig. 2.43) (Form Feedout Unit) (Fig. 2.43)

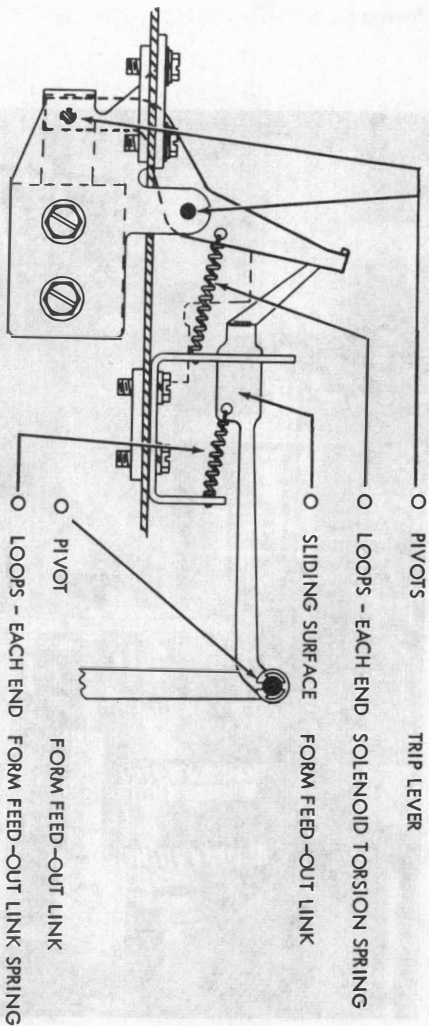

28 TELETYPEWRITER

P34.503

Page 37

BASE  
LUBRI-  
CATION

2.45 Variable Speed Drive — Speed Selecting Mechanism

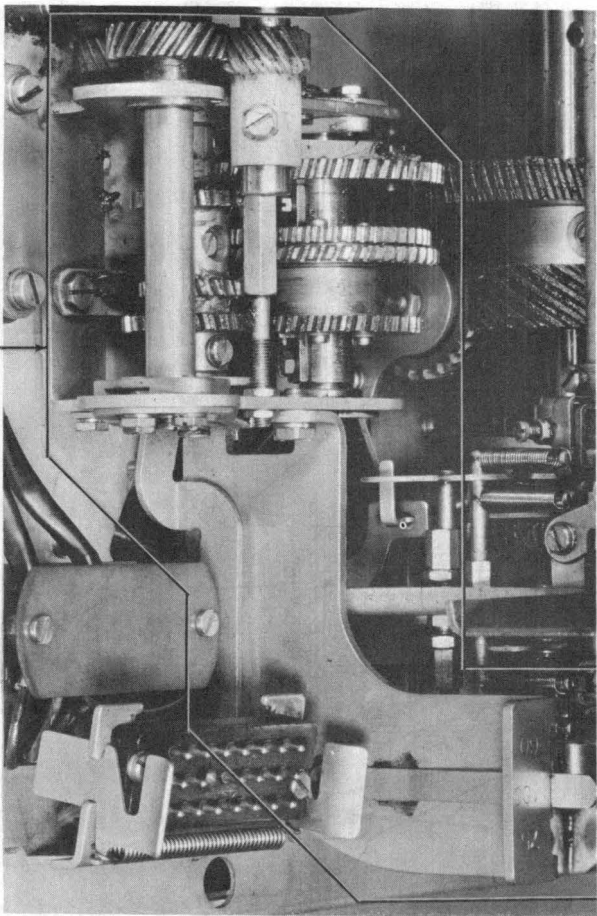

SPEED SELECTING MECHANISM

## 2.46 Variable Speed Drive — Speed Selecting Mechanism

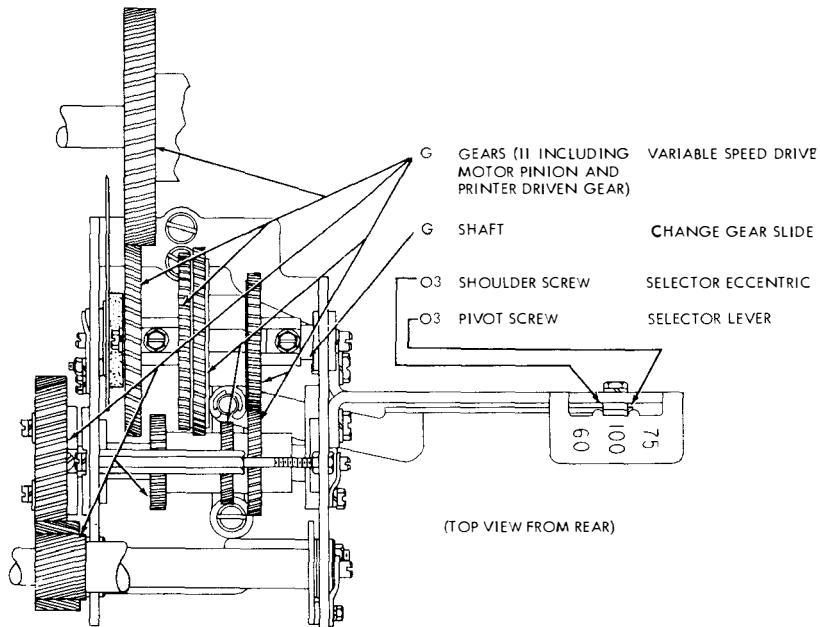

## 2.47 Variable Speed Drive — Speed Selecting Mechanism (Contd)

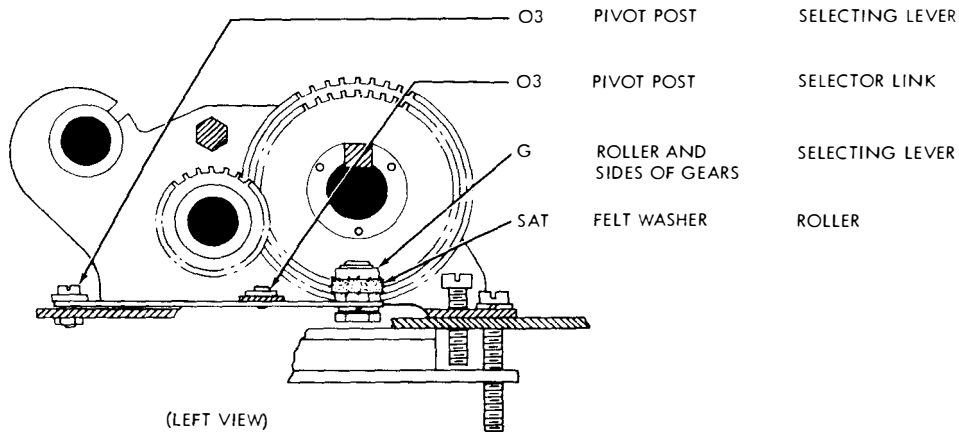



2.48 Universal Keyboard Switch (Not Shown on a Locator Photograph)

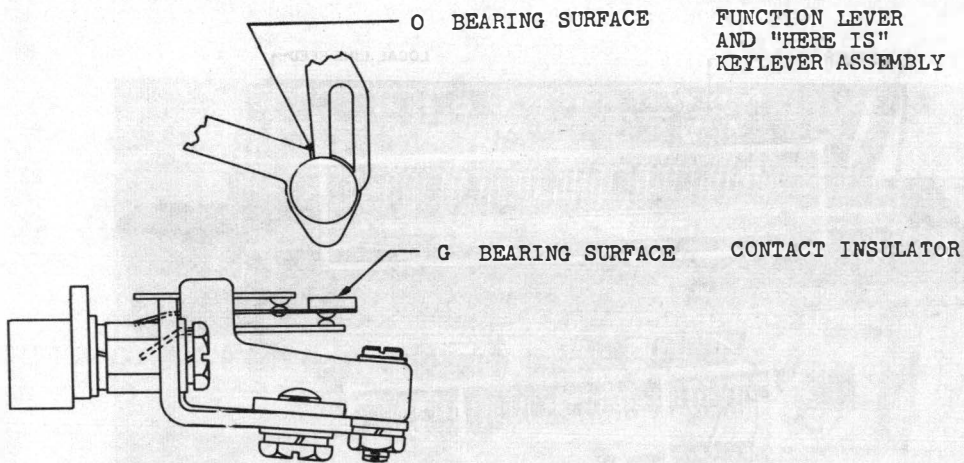

28 TELETYPEWRITER

BASE  
LUBRI-  
CATION

P34.503

Page 41

### 3. EARLIER DESIGN KSR BASE (KEYBOARD)

#### 3.01 Codelever, Local Carriage Return, Local Line Feed and Keyboard Lock Mechanisms.

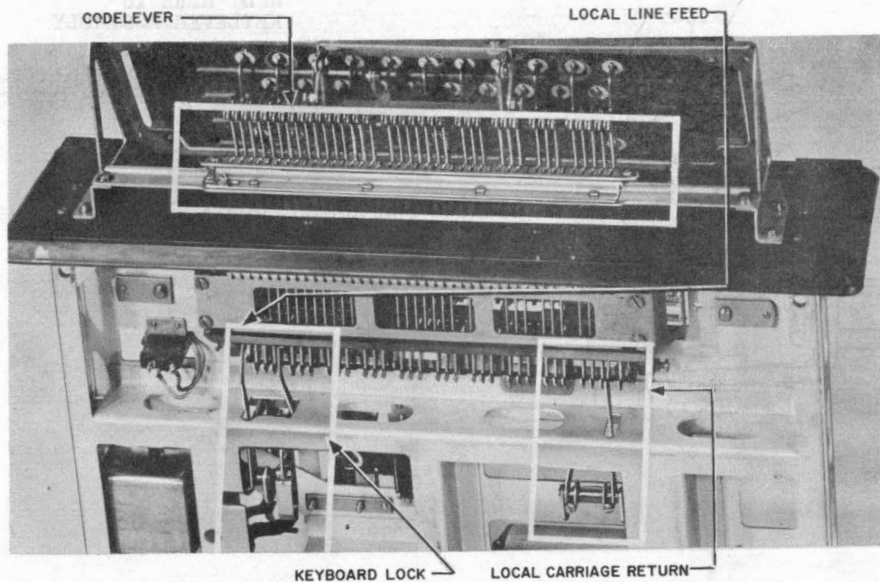

### 3.02 Codelever

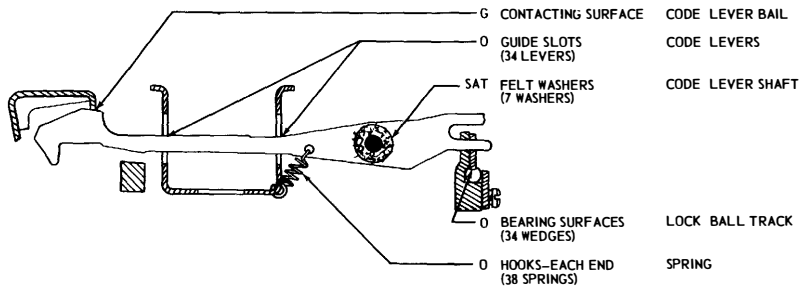

### 3.03 Local Carriage Return

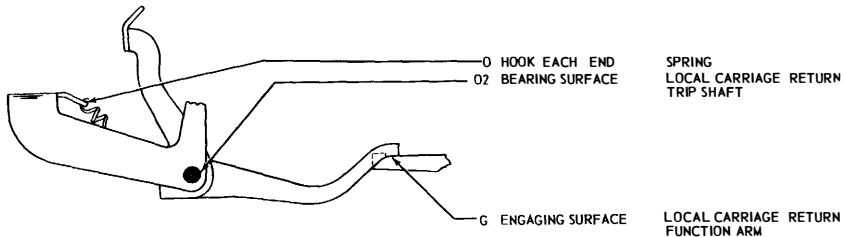

### 3.04 Local Line Feed

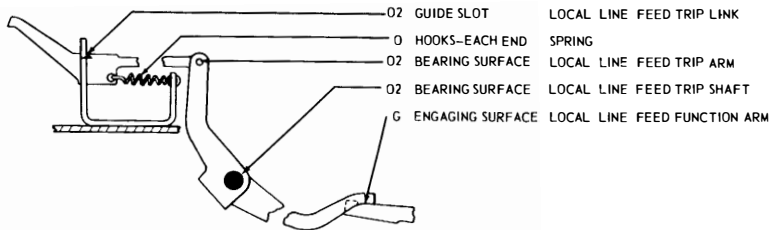

### 3.05 Keyboard Lock

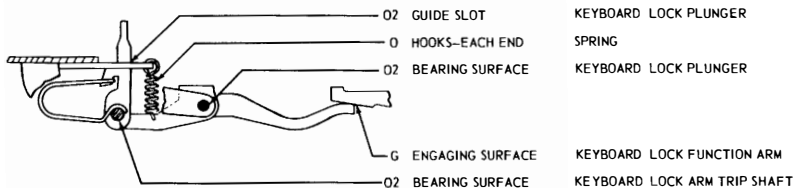

### 3.06 Margin Indicator, Contact Box, Codebar, and Keyboard Selector Mechanisms

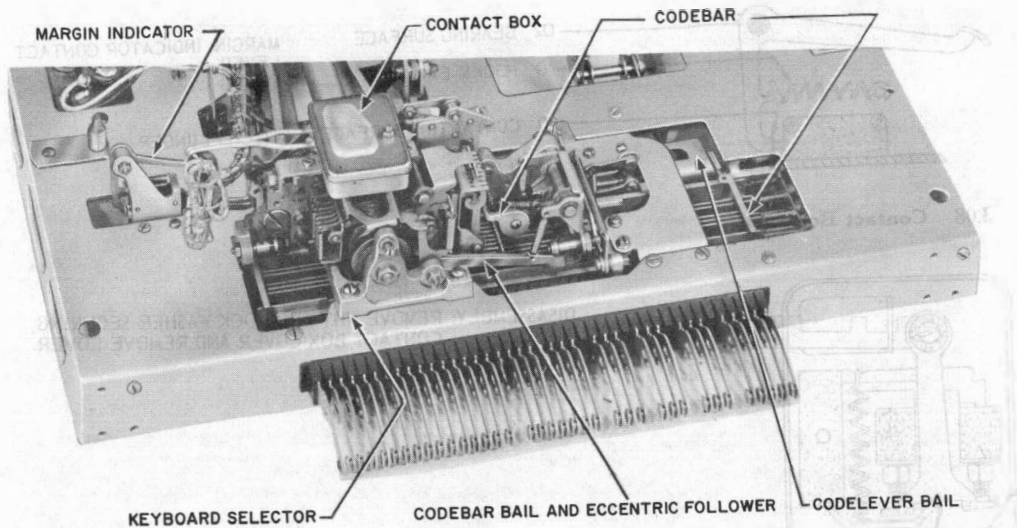

28 TELETYPEWRITER  
BASE  
LUBRI-  
CATION

P34.503

Page 45

### 3.07 Margin Indicator (Rear View)

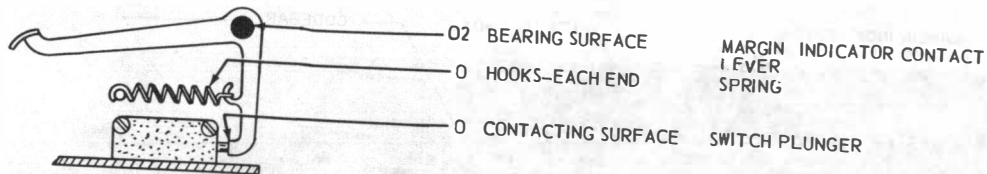

### 3.08 Contact Box

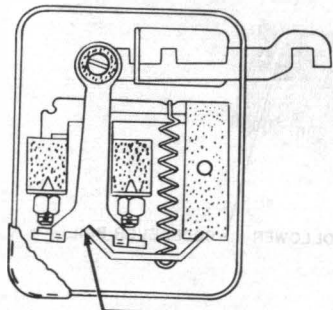

DISASSEMBLY: REMOVE NUT AND LOCK WASHER SECURING CONTACT BOX COVER AND REMOVE COVER.

G ENGAGING SURFACE  
CONTACT TOGGLE

### 3.09 Codebar

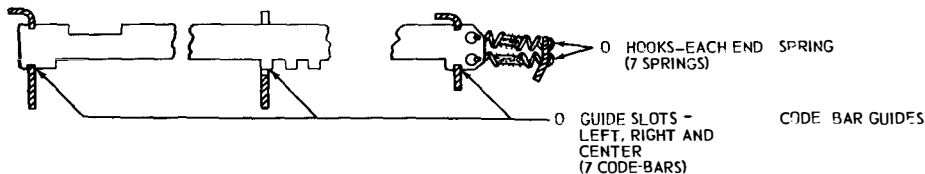
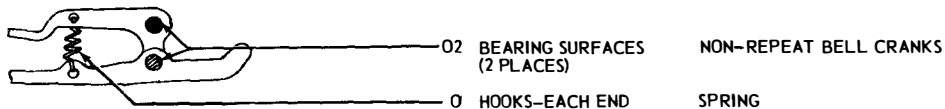
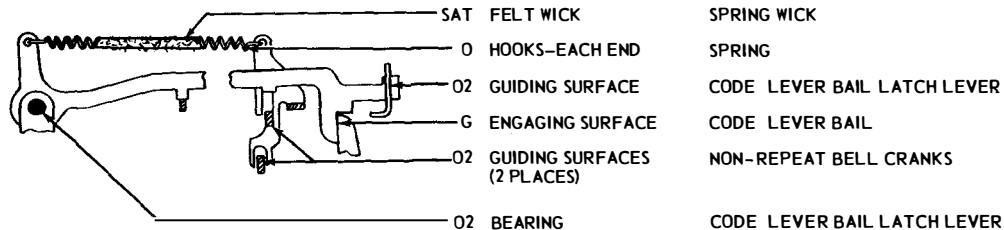

### 3.10 Keyboard Selector

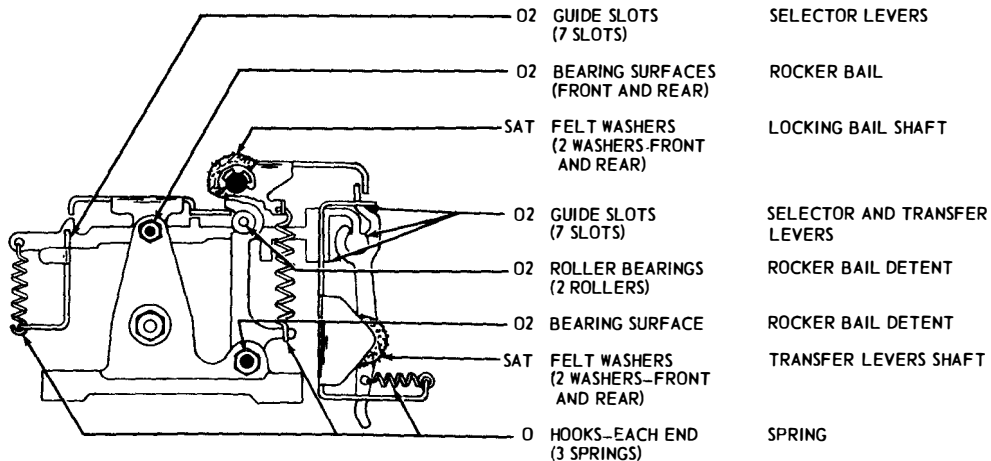



### 3.11 Codebar Bail and Eccentric Follower

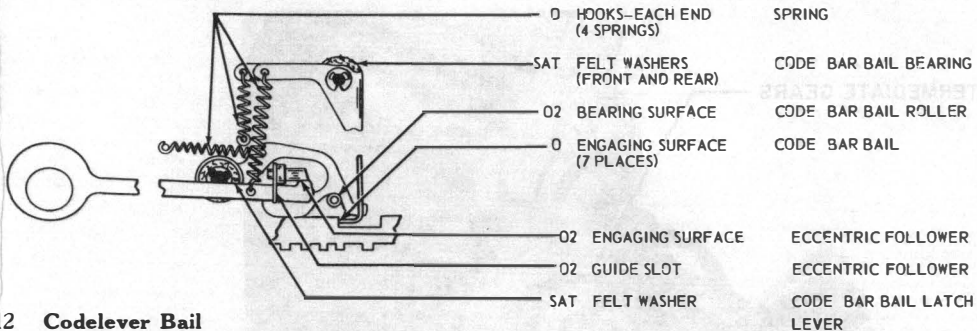

### 3.12 Codelever Bail

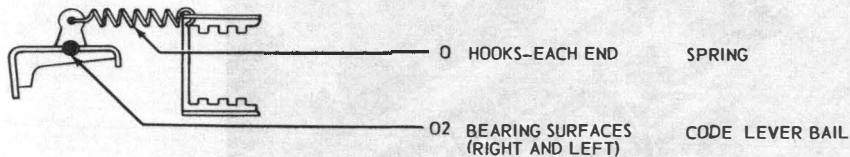

### 3.13 Intermediate Gears and Shaft

INTERMEDIATE GEARS

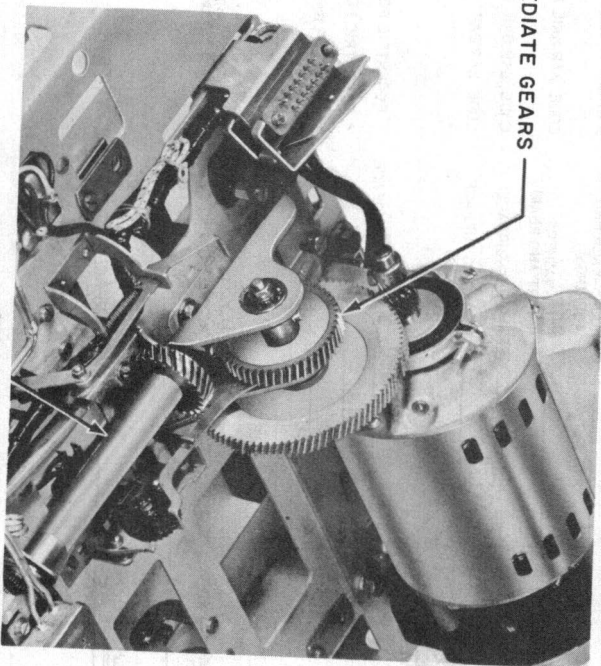

SHAFT

3.14 **Intermediate Gears** (For motor, see section entitled 28 Motor Unit, Lubrication)

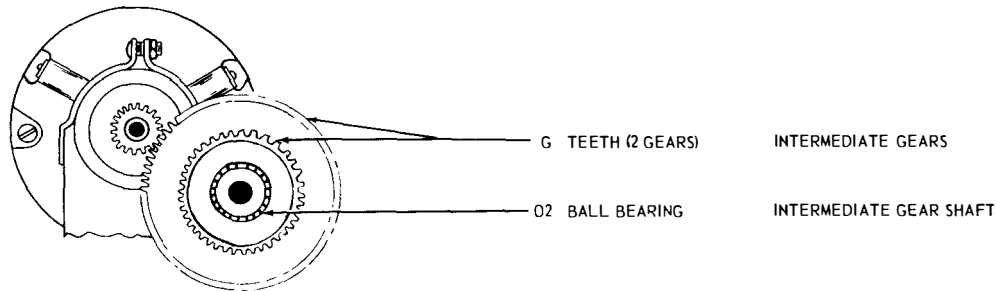

### 3.15 Shaft

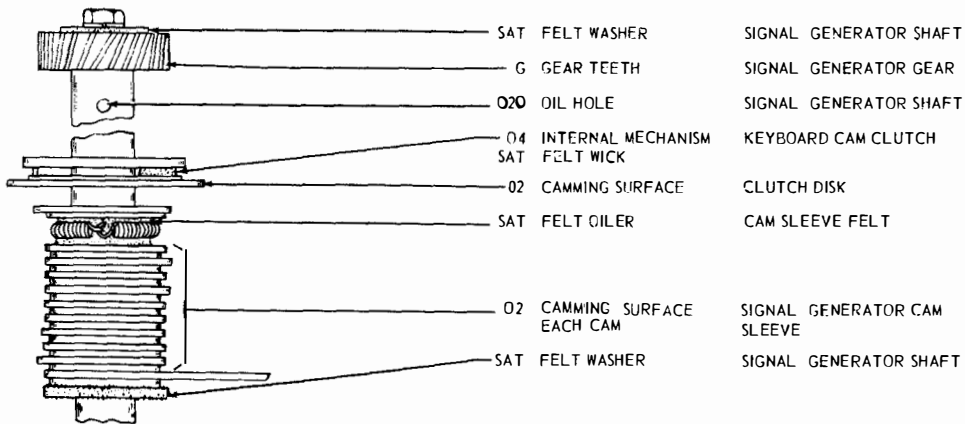

3.16 **Signal Generator and Time Delay Mechanisms (Rear View)**

**SIGNAL GENERATOR**

**SIGNAL GENERATOR CLUTCH**

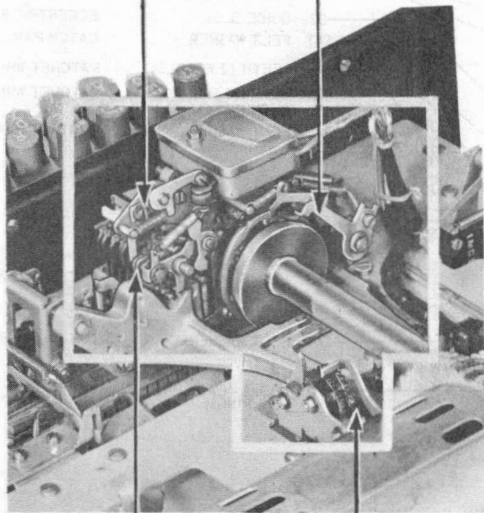

**INTERMEDIATE LEVER**

**TIME DELAY MECHANISM**

### 3.17 Time Delay Mechanism

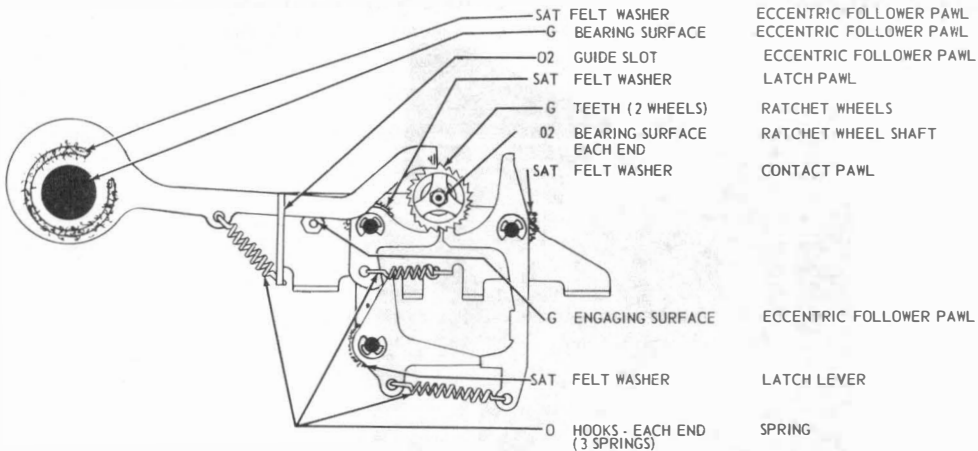

### 3.18 Signal Generator

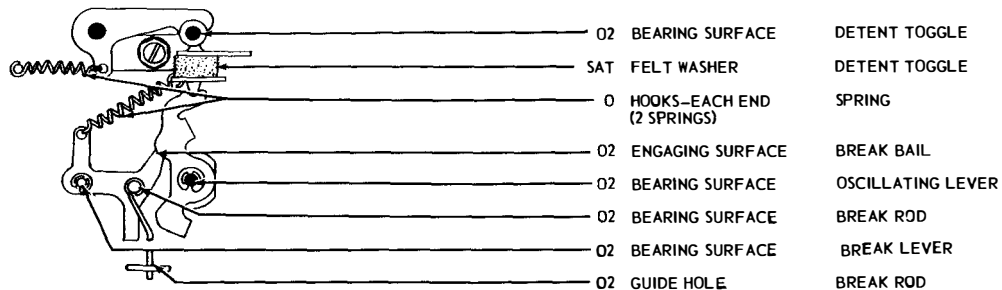

### 3.19 Signal Generator Clutch

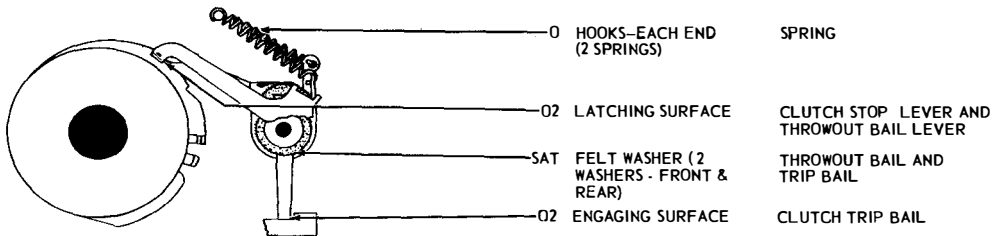

### 3.20 Intermediate Lever (Signal Generator)

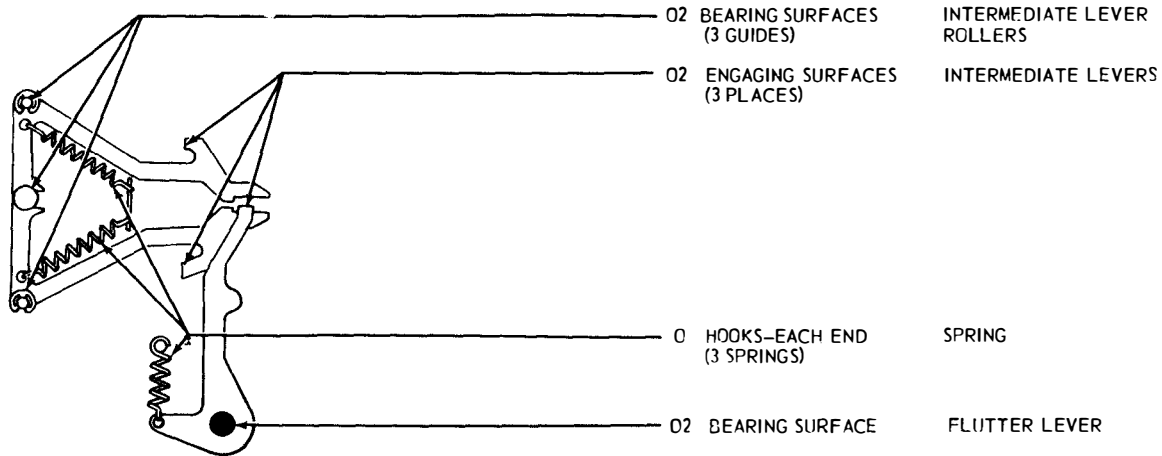



### 3.21 Signal Line Break and Repeat-space Mechanisms (Rear View)

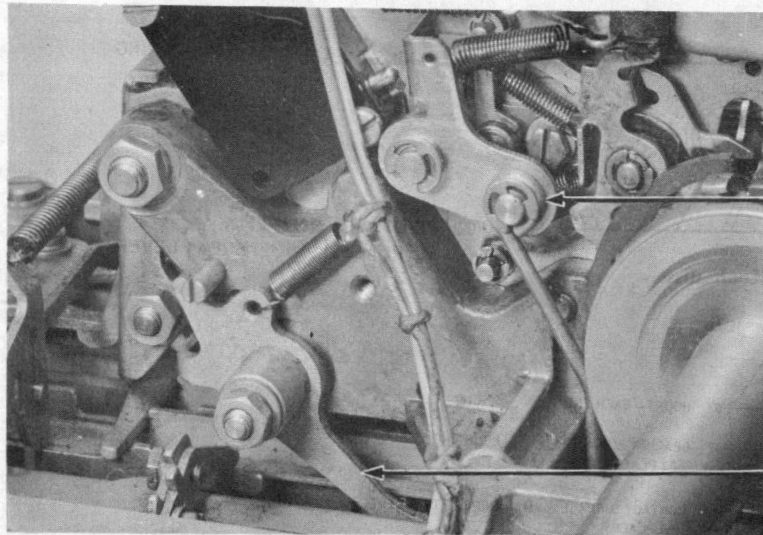

SIGNAL LINE BREAK  
MECHANISM

REPEAT-SPACE  
MECHANISM

28 TELETYPEWRITER  
BASE  
LUBRI-  
CATION

P34.503

Page 57

### 3.22 Signal Line Break Mechanism

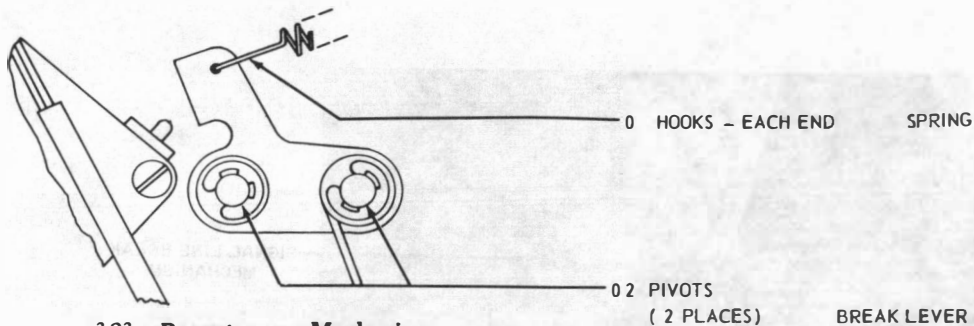

### 3.23 Repeat-space Mechanism

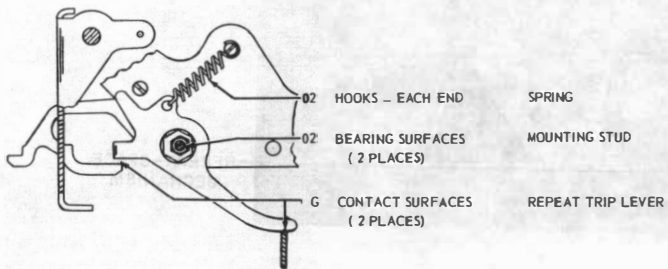

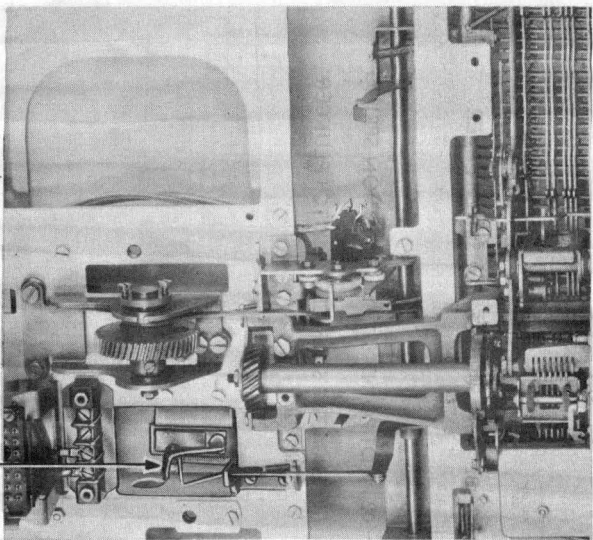

PAPER FEEDOUT

### 3.25 Paper Feedout

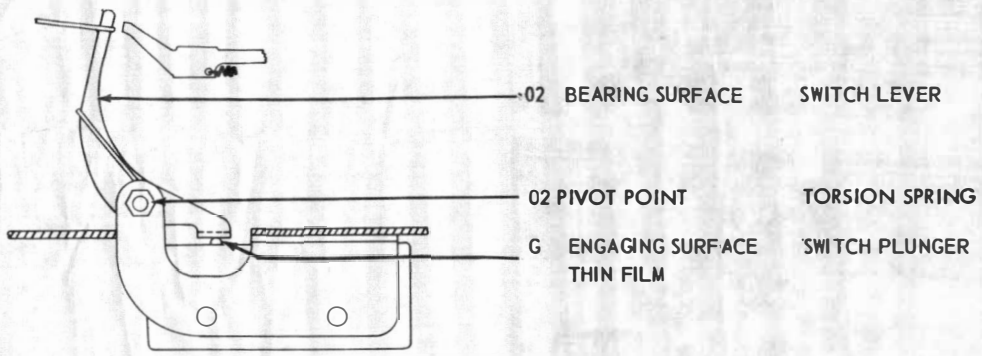

### 3.26 Answerback: Blinding (Pulsing) Contacts (Not Shown on a Locator Photograph)

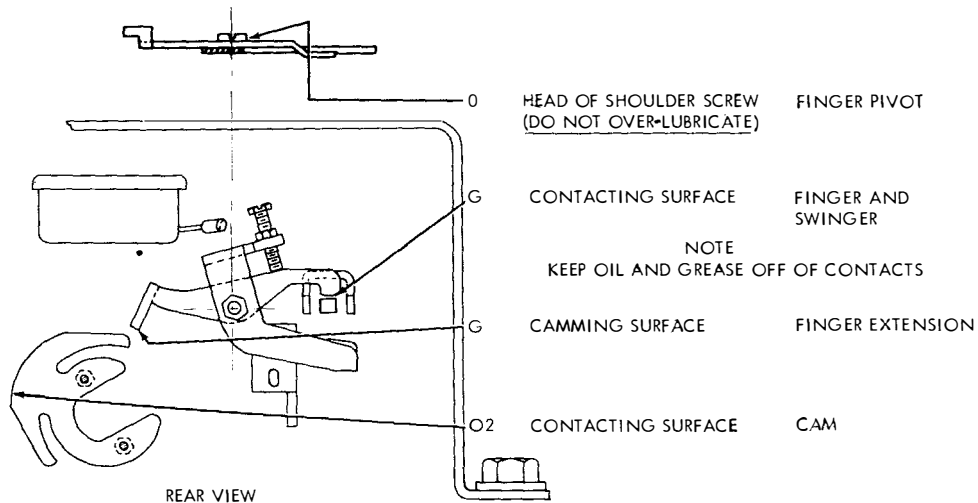

### 3.27 Answerback: Driving Mechanism (Not Shown on a Locator Photograph)

- HOOK (EACH END)
- ENGAGING SURFACE
- 2 BEARING SURFACES (2 PLACES)
- PIVOT POINT

- DRIVE LINK SPRING
- BLOCKING LEVER AND STOP LEVER
- DRIVE PLATE SHAFT AND SIDE PLATES
- OPERATING BAIL

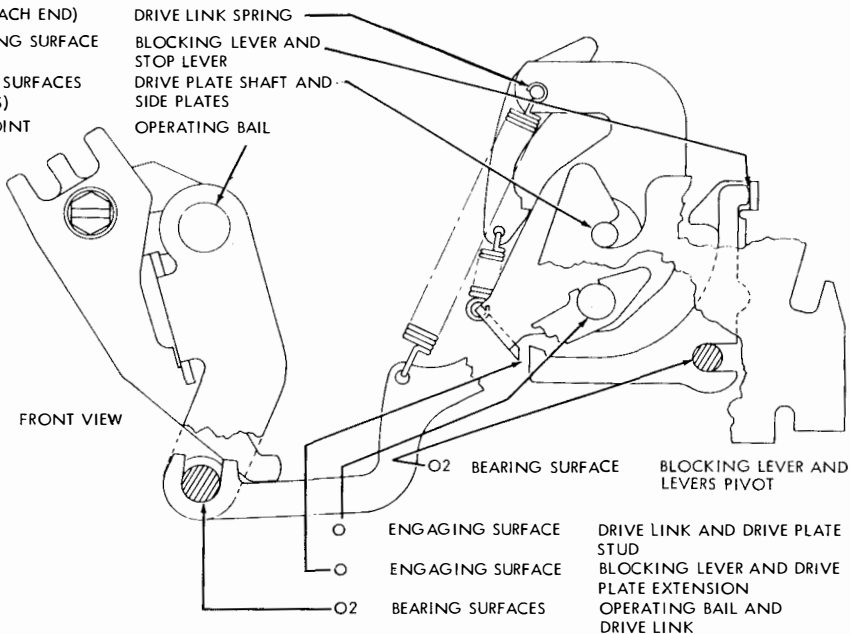

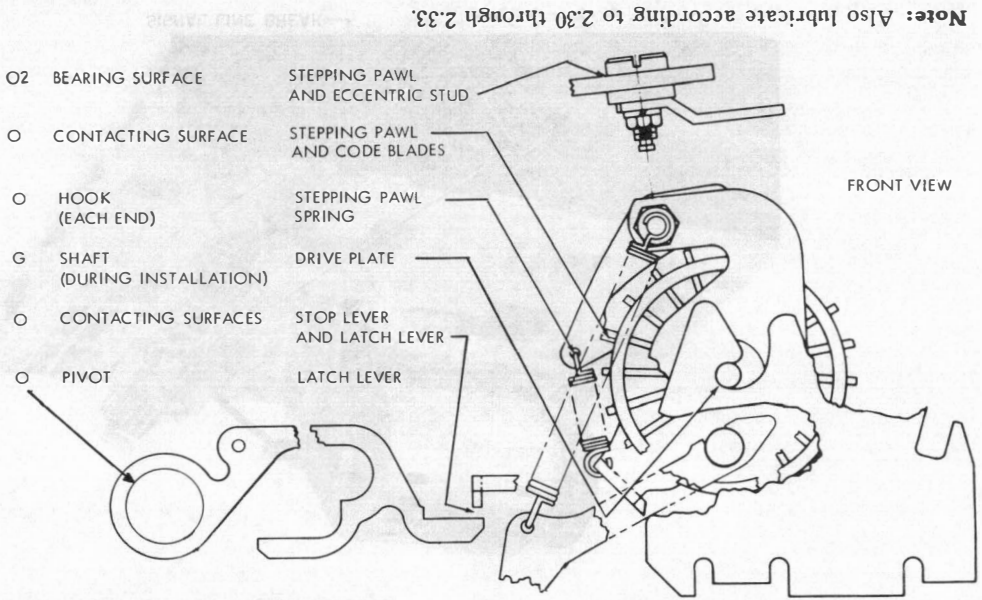

**Note:** Also lubricate according to 2.30 through 2.33.

#### 4. RECEIVING-ONLY (RO) BASE 4.01 Signal Line Break Mechanism

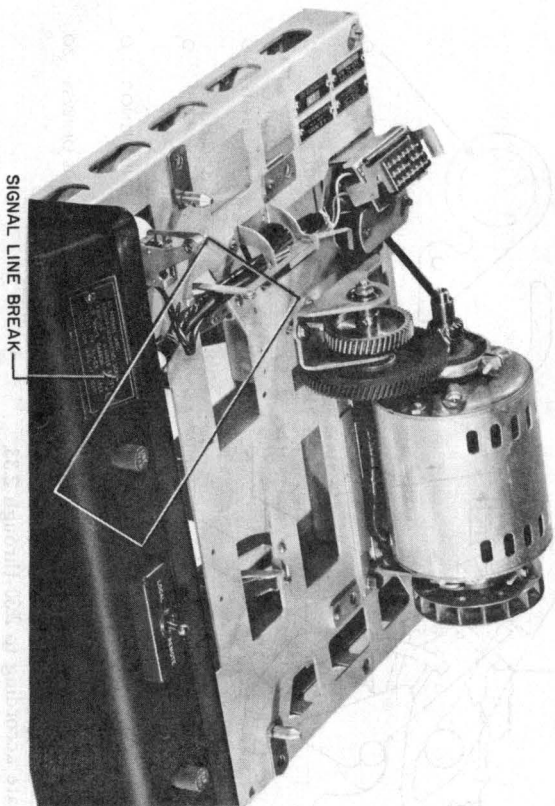



## 4.02 Signal Line Break Mechanism

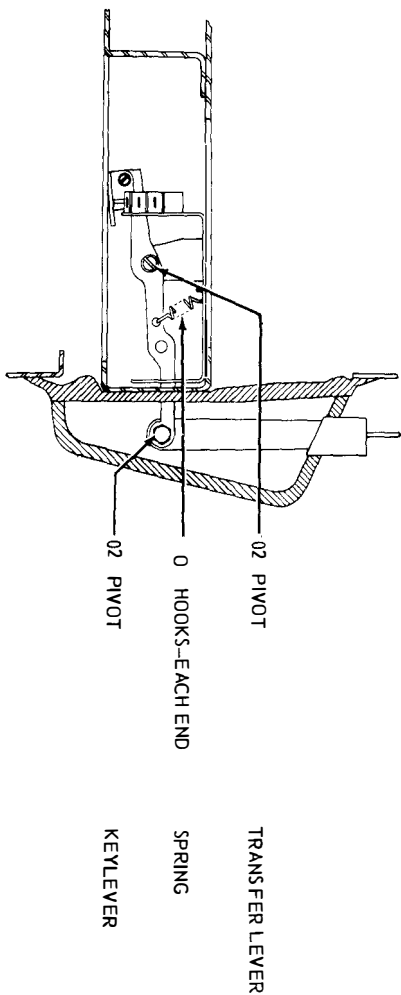

28 TELETYPEWRITER

**P34.503**

Page 65

BASE  
LUBRI-  
CATION

## 5. ASSOCIATED BELL SYSTEM PRACTICES

5.01 The following Bell System Practice contains an index of information that may be related to this section.

<u>Subject</u>	<u>Section</u>
Alphabetical Index of 28-type Equipment, Bell System Practices, and Associated 28ASR Station Drawings	P34.001