

**BELL SYSTEM PRACTICES**  
Teletypewriter and Data Stations

**ADDENDUM P34.308**  
Issue 1, June, 1962  
AT&T Co Standard

## **28-TYPE TYPING REPERFORATOR UNITS AND BASES WIRING DIAGRAM**

### **1. GENERAL**

- 1.001 This addendum supplements Section P34.308, Issue 4.
- 1.002 This addendum is issued to add the wiring of the 28E typing reperforator base arranged to mount a standard 28-type typing reperforator and a 28A motor unit.

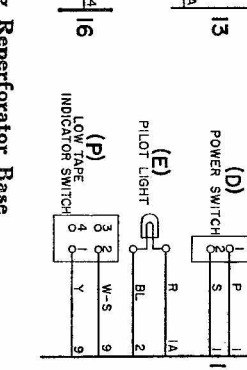
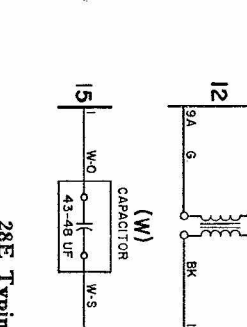
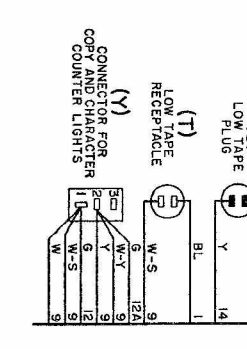
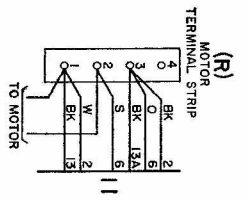
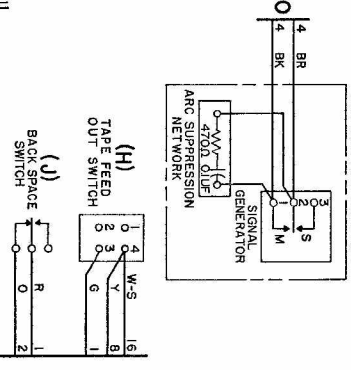
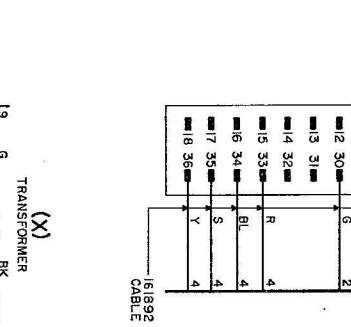
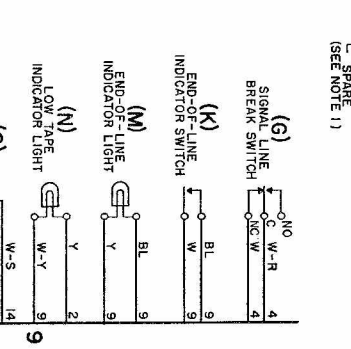
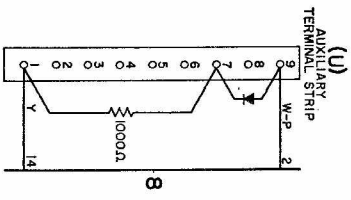
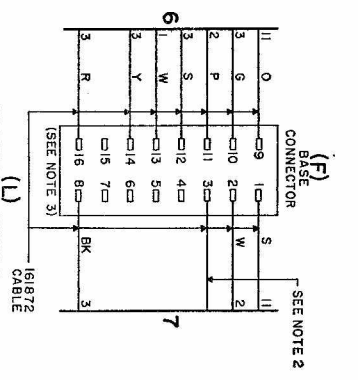
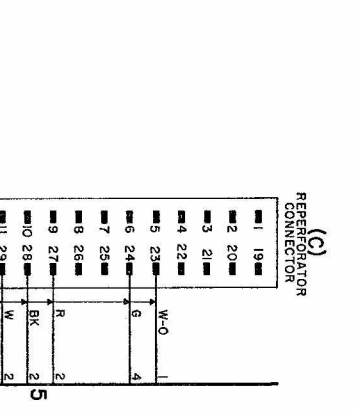
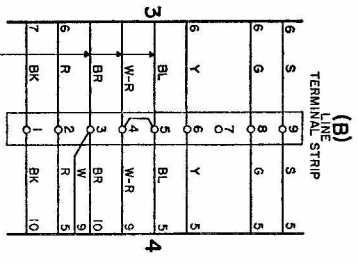
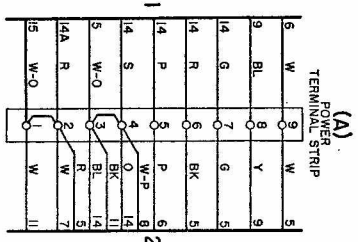

NOTES:  
1. THESE SPARES ARE PART OF THE 161878 CABLE AND ARE TIED BACK AT THE F CONNECTOR.  
2. TERMINAL 3 TO BE CONNECTED TO A GROUND SCREW ON BASE.  
3. UNITS INCLUDE MATING 16-PT CONNECTOR (159541) FOR CUSTOMERS USE, AS SHOWN BELOW.

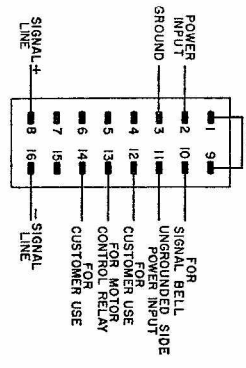

**BELL SYSTEM PRACTICES**  
**Teletypewriter and Data Stations**

**SECTION P34.308**  
**Issue 4, March, 1962**  
**AT&T Co Standard**

## **28-TYPE TYPING REPERFORATOR**

### **UNITS AND BASES**

### **WIRING DIAGRAM**

#### **1. GENERAL**

1.01 This section shows the wiring of the 28A, 28B, 28C, 28D, 28E, 28F, 28G, 28J, 28K, 28L and 28M typing reperforator units and 28A, 28B, 28C, and 28D typing reperforator bases.

1.02 This section is reissued to add 28L and 28M to the title of the drawing showing the wiring of the 28C, 28D, 28E, 28F, 28G, 28J, and 28K typing reperforator units, and to show that the motor (not part of 28D typing reperforator base) connects to terminals 7 and 9 of the (DH) terminal strip.

28A & 28B TYPING REPERFORATOR UNITS  
28A TYPING REPERFORATOR BASE

- NOTES:  
1. SELECTOR MAAGNETS ARE TO BE WIRED AS SHOWN FOR 30 MILLIAMPERE OPERATION WHEN LINE RELAY IS USED.  
2. FOR 28B TYPING REPERFORATOR UNIT ONLY. (0.105 AMPERE, 148 VOLTS, DC)  
3. 28A MOTOR UNIT NOT FURNISHED AS PART OF 28A TYPING REPERFORATOR BASE.

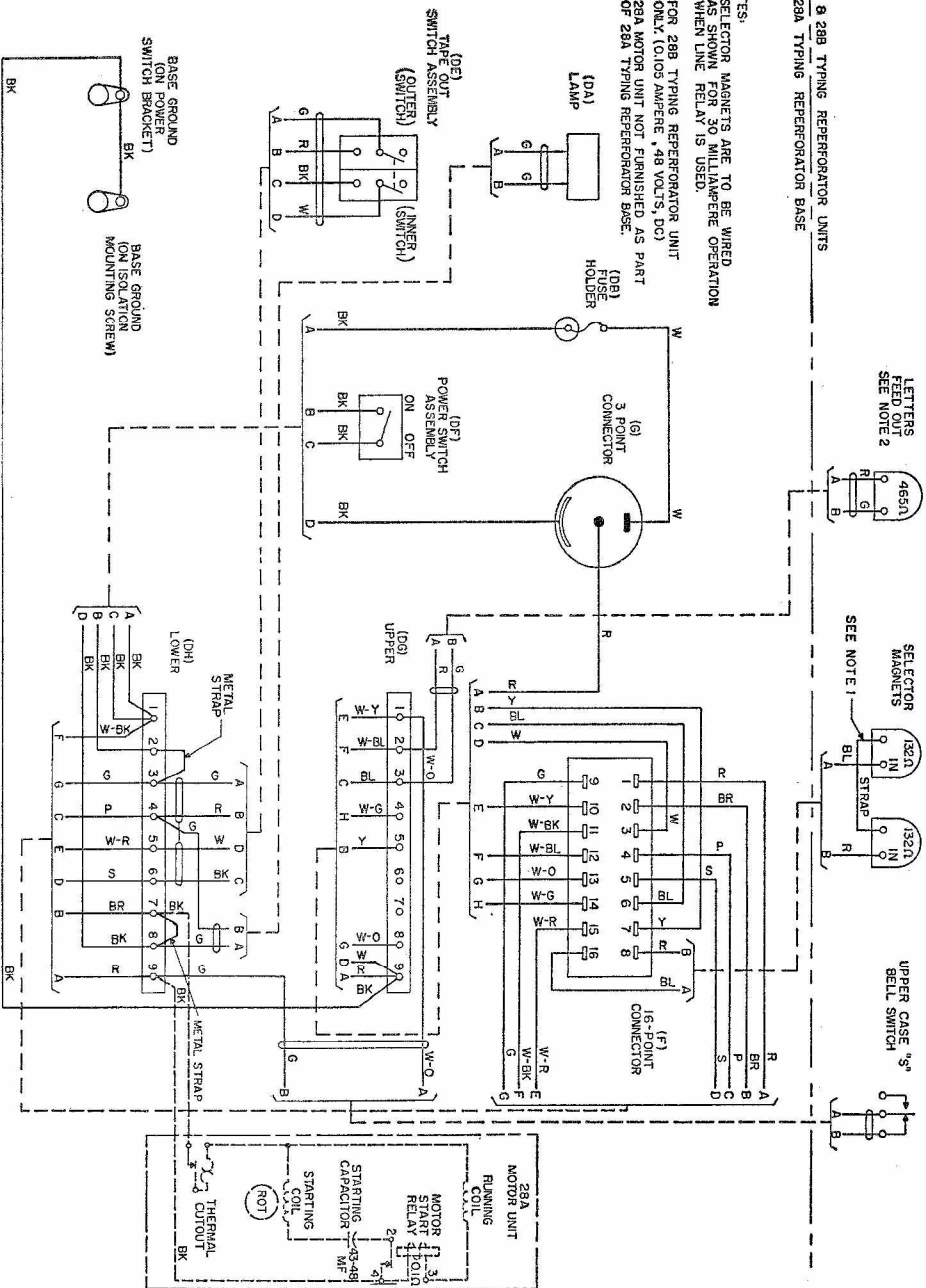

28A and 28B Typing Reperforator Units  
28A Typing Reperforator Base

- NOTES:
1. CONNECT SELECTOR MAGNETS AS SHOWN FOR 20 OR 30 MA OPERATION
  2. DOTTED LINES INDICATE STRAPPING REQUIRED TO MAKE SHIMMERS COMMON

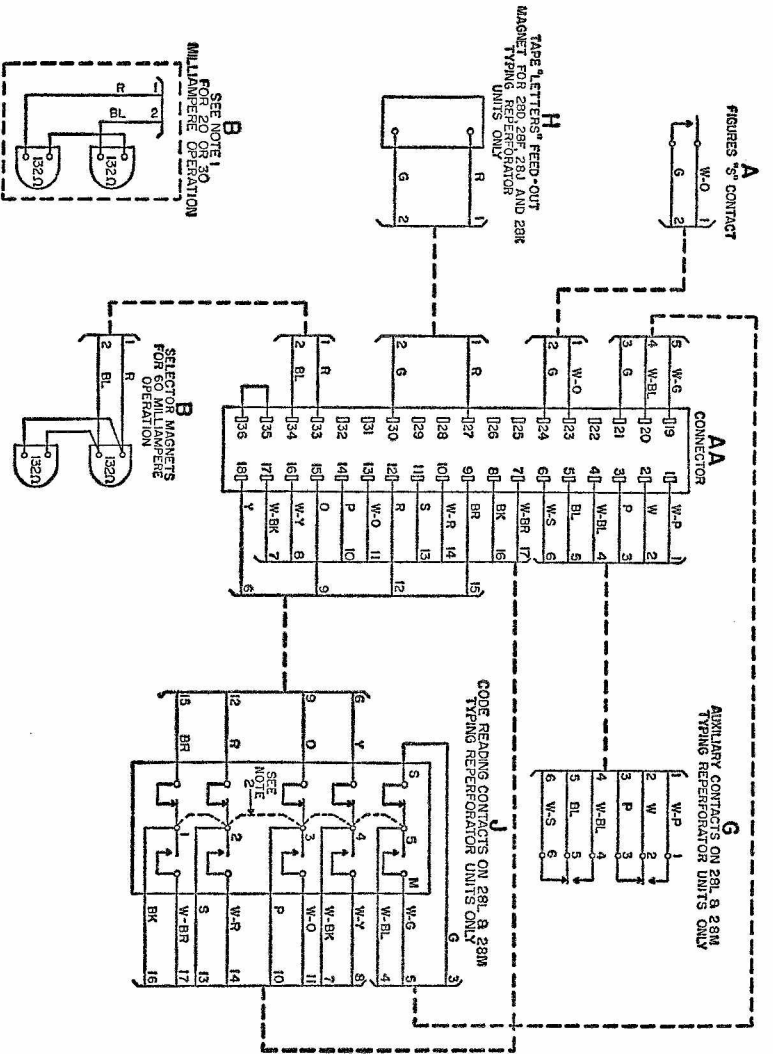

28C, 28D, 28E, 28F, 28G, 28J, 28K,  
28L and 28M  
Typing Reperforator Units

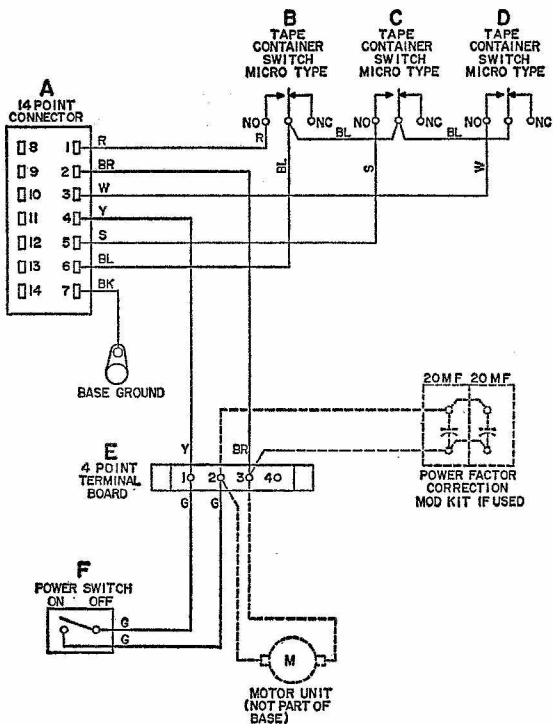

28B Typing Reperforator Base

28C-TYPE TYPING REPERF.

28C Typing Reperforator Base

