

BELL SYSTEM PRACTICES
Teletypewriter Stations

SECTION P36.618
Issue 4, June, 1953
AT&T Co Standard

TABULATOR MECHANISM

TRANSMITTER-DISTRIBUTOR CONTROL AND TABULATOR CUT-OUT FOR 15 TYPING UNIT REQUIREMENTS AND PROCEDURES

1. GENERAL

- 1.01 This section gives the requirements and adjusting procedures for the:
- TP84925 Tabulator mechanism (FIGS G)
 - TP87860 Tabulator mechanism (FIGS Z)
 - TP89992 Transmitter-distributor control
 - TP122362 Tabulator cut-out
- 1.02 It is reissued to combine with it the addendum, Issue 1, and to add the tabulator cut-out.

2. DESCRIPTION OF OPERATION

A. Tabulator Mechanism

2.01 When Tab (upper case G or Z) is selected, the selecting vanes are so positioned that the tabulator function lever (Fig. 1) is drawn forward by its spring. Pivoting about the bearing, shown shaded, the function-lever extension rises vertically under the tabulator latch bar, lifting it and imparting vertical movement to the space pawl link. The vertical travel is sufficient to cause the rear spacing escapement pawl to clear the teeth on the spacing escapement ratchet. This position of the escapement pawl is maintained by the tabulator latch engaging the forward (left in Fig. 1) extension of the tabulator latch-bar. The tabulator latch is carried below the pivots of the tabulator bar (not shown in Fig. 1) which in moving toward the typing unit (to the right in the figure) causes the lower end of the tabulator latch to move to the left and engage the toe of the latch bar.

**TABULATOR MECHANISM
TRANSMITTER-DISTRIBUTOR CONTROL
AND TABULATOR CUT-OUT FOR
15 TYPING UNIT
REQUIREMENTS AND PROCEDURES**

P36.618

Page 1

2.02 With the spacing escapement ratchet thus free to rotate under power received from the main shaft through the spacing clutch, the typebar carriage moves smoothly across the page until the carriage pawl arrives at a stop on the tabulator bar. The carriage pawl is not held by the stop but passes it and in so doing cams the tabulator bar away from the typing unit. This causes the tabulator latch to move to the right (in Fig. 1) and release the tabulator latch bar. The space pawl link is thus lowered to its unoperated position permitting the rear spacing escapement pawl to engage a tooth on the spacing escapement ratchet and stop the carriage. Thereafter the carriage moves one space at a time with the individual typed characters until tabulation is again desired and accomplished by the FIGS G or FIGS Z signal. The TAB signal must thus be repeated each time movement of the carriage to the next tab stop is desired.

Fig. 1

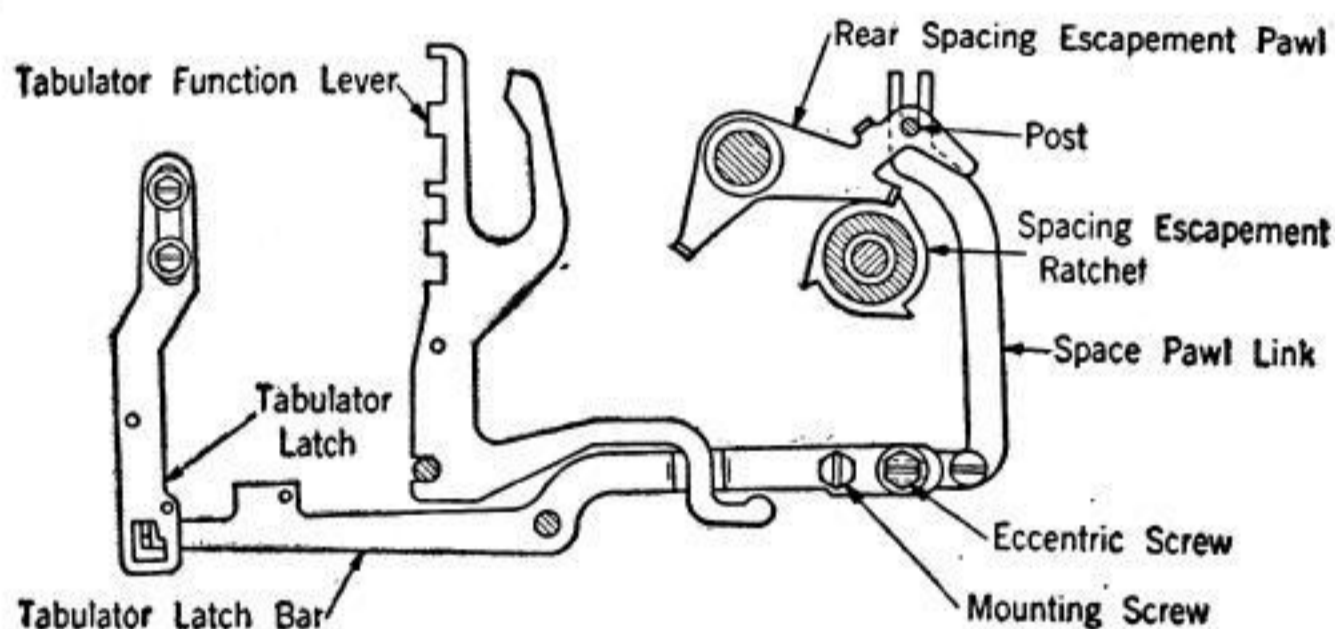

Fig. 1

B. Transmitter-Distributor Control

2.03 When a transmitter-distributor is used with a typing unit arranged for tabulation, the transmitter-distributor must stop while the carriage is moving for tabulation. Otherwise a character intended to be printed after the next tab stop might be printed while the carriage was in motion. A contact on the typing unit, in series with the stop magnet of the transmitter-distributor, is held open while the carriage is in motion between tab stops. Thus the transmitter-distributor is prevented from sending until the carriage comes to rest. Fig. 3

C. Tabulator Cut-Out

2.04 The TP122362 set of parts provides manual switch control of the tabulating feature by TWX customers who wish to tabulate only some part of their traffic.

2.05 The mechanism consists of a switch, ac-dc electromagnet and wiring. These parts normally block tabulation. After a TWX connection has been established the attendants, by prearrangement, bell signal, typed message or other cue, agree to tabulate and manually set the paper at the proper starting point. Each attendant momentarily closes the control switches operating the magnet which locks up and permits tabulation. When the power is turned off at the end of transmission, the magnet releases, disabling tabulation. **Fig. 2**

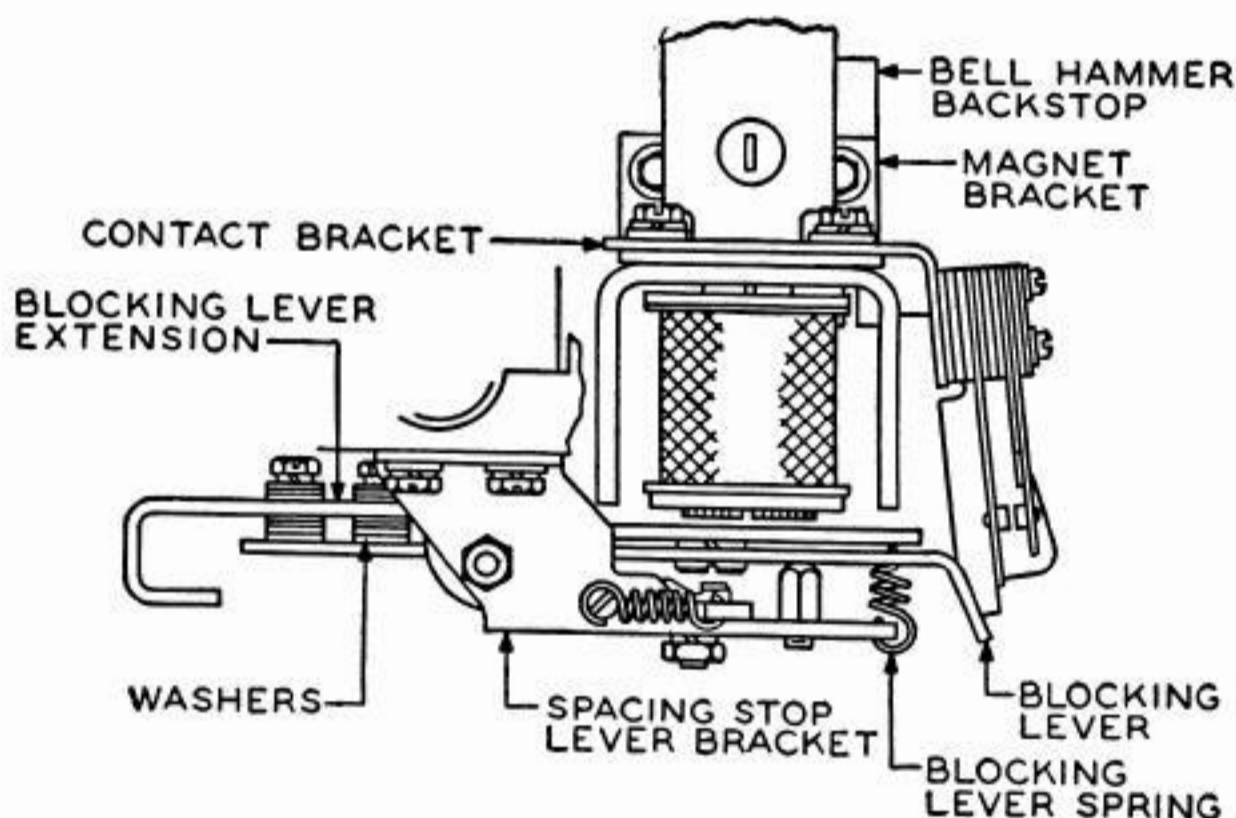

TABULATOR CUT-OUT MECHANISM
FOR 15 TYPING UNIT

Fig. 2

3. REQUIREMENTS AND PROCEDURES

A. General

3.01 In addition to meeting the requirements of this section, a typing unit which is equipped with a tabulator should be adjusted in accordance with Section P36.610 and,

TABULATOR MECHANISM
TRANSMITTER-DISTRIBUTOR CONTROL
AND TABULATOR CUT-OUT FOR
15 TYPING UNIT
REQUIREMENTS AND PROCEDURES

in the case of sprocket-feed machines, Section P36.619, giving particular attention to the following before checking the tabulator mechanism:

- (a) Spacing-escapement-pawl operating-arm.
- (b) Spacing-clutch tension.
- (c) Send-receive mechanism plate.
- (d) Send-receive reset-lever upper adjusting-screw.
- (e) Reset-lever lower adjusting-screw.
- (f) Right and left motor-stop-contact assemblies, if the typing unit is equipped with a motor-stop mechanism.

B. Tabulator Mechanism

3.02 **Tabulator bar** should be parallel to the front carriage rail within .010".

- (a) To gauge, measure gap between tip of carriage pawl (tabulator pawl on the typebar carriage) and tabulator-stops located at each end of tabulator bar when the carriage is in position immediately preceding engagement of pawl and stops.

Note: If pawl touches either stop, rotate tabulator latch forward about its lower mounting-screw until pawl clears both stops.

- (b) To adjust, reposition tabulator bar right-bearing bushing nut.

3.03 **Tabulator bar** should have some end-play, not more than .004", and should be located centrally on the send-receive-break mechanism plate except on units equipped with an extension for operating the tabulator contact lever of the tabulator transmitter-distributor control on the send-receive-break contact spring assembly, when it should be located so that the extension clears the tabulator contact lever mounting bracket by not more than 1/16".

Fig. 3

- (a) Gauge by eye and feel.
- (b) Adjust by means of pivot screws on which the tabulator bar pivots.

Note: If send-receive-break contact-spring assembly is shifted check adjustment of reset-lever upper adjusting screw, see Section P36.610.

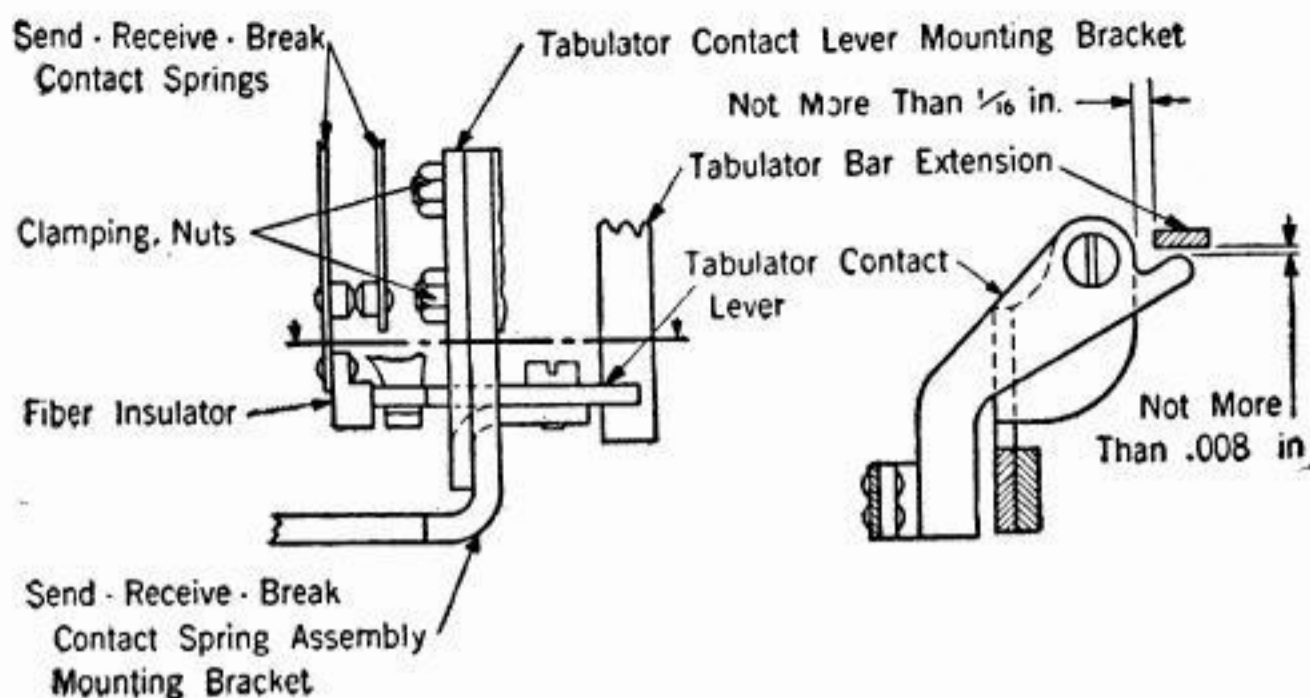

Fig. 3

3.04 **Tabulator contact lever** of the TP89992 tabulator transmitter-distributor control on teletypewriters so equipped should clear the front surface of the tabulator bar extension by not more than .008" when the handle of the send-receive-break mechanism is in the send position, the long arm of the contact lever is just touching the fibre insulator of the send-receive-break contact spring, and the tabulator latch-bar is in the unlatched position. **Fig. 3**

(a) To adjust, shift the send-receive-break contact spring assembly on the base and if necessary shift the tabulator contact-lever mounting-bracket with respect to the send-receive-break contact-spring assembly mounting-bracket.

Note: There is an adjusting screw mounted on the ← tabulator contact lever in the TP89992 set of parts. ←

3.05 **Tabulator-bar spring tension** should be Min 10 oz, Max 14 oz measured with a TP110444 scale pulling in line with the spring on the tabulator bar as the bar starts to move when the front extension of the tabulator latch-bar is in its uppermost position, except on units equipped with tabulator bars having an extension for operating the tabulator contact lever on send-receive-break contact spring assembly in which case the spring tension should be Min 14 oz, Max 18 oz.

3.06 **Tabulator Latch:** The lobe on the tabulator-function-lever rear extension should just touch the tabulator latch-bar when:

1. Platen in the LTRS position, G or Z selected.

TABULATOR MECHANISM
TRANSMITTER-DISTRIBUTOR CONTROL
AND TABULATOR CUT-OUT FOR
15 TYPING UNIT
REQUIREMENTS AND PROCEDURES

2. Main shaft rotated until the tabulator function lever is resting against the sixth vane.
3. Tabulator latch-bar resting against the top of the notched rectangular hole in the tabulator latch.
 - (a) To adjust, reposition the tabulator latch.

3.07 **Front Spacing-Escapement-Pawl:** (For units equipped with TP124625 front spacing-escapement-pawl assembly, to improve operation when tabulating at 75 speed.) Rotate the main shaft until the printing bail is in its extreme rear position. Disengage the rear spacing-escapement-pawl from the spacing-escapement ratchet and rotate the ratchet assembly until a ratchet tooth is in line with the toe of the front spacing-escapement-pawl extension. Adjust the extension by means of its clamping screw so that there is Min .040", Max .060" clearance between the top of the ratchet tooth and the toe of the extension.

3.08 **Tabulator function-lever spring tension** shall be Min 3-1/4 lb, Max 4-3/4 lb measured with a TP4841 scale at right angles to the tabulator-function-lever rear extension just in front of the lobe as the lever starts to move when the printing bail is in its extreme rear position.

3.09 **Tabulator Latch-Bar Extension:** The space-pawl post should just touch the bottom of the slot in the space-pawl link, when:

Fig. 1

1. Main shaft is in the normal stop position.
2. Tabulator latch bar is unlatched.
3. Space pawl is fully engaged with the spacing escapement ratchet.
4. Front projection of the tabulator latch-bar is resting against the top of the notched rectangular hole in the tabulator latch.

(a) To adjust, reposition the latch-bar extension by means of its eccentric screw.

3.10 **Tabulator Latch-Bar Spring Tension** should be Min 1-1/2 oz, Max 3 oz measured at right angles to the tabulator latch-bar, just to the rear of the spring, as the latch-bar starts to move, when:

1. Typing unit is resting on its right side.
2. Printing bail is in its extreme rear position.
3. Rear spacing-escapement-pawl is resting on the top of a ratchet tooth.
4. Tabulator bar is held so that the latch-bar is free of the latch.

3.11 **Tabulator Latch Clearances:** Clearance between the upper edge of the tabulator latch-bar's front projection and the latching surface of the tabulator latch should be Min .008" with the platen in the FIGS position, G or Z selected and the main shaft rotated until the tabulator function lever is completely selected.

Fig. 4

(a) To adjust, reposition tabulator latch up or down and tighten the lower tabulator latch mounting-screw and check 3.04.

Fig. 1

Note: Check 3.06 and see that the carriage pawl spring is securely in place.

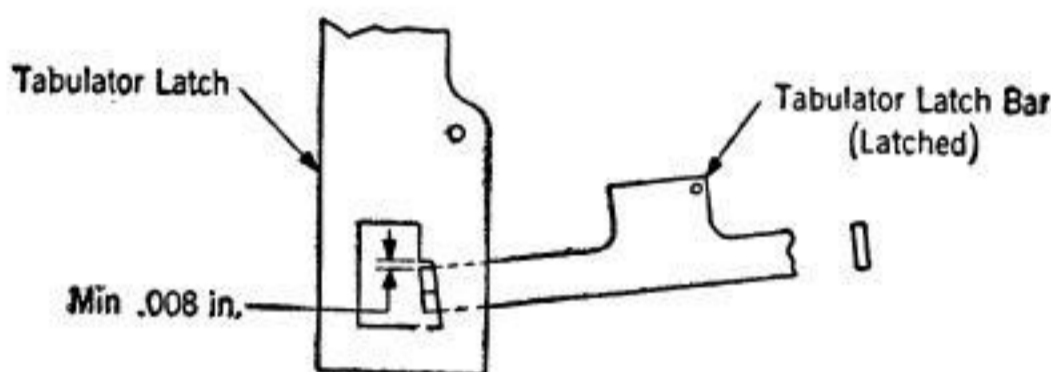

Fig. 4

3.12 Clearance between the rear surface of the **tabulator latch-bar** and the face of the tabulator latch above the latching surface shall be Min .010", Max .015" under the following conditions:

Fig. 5A

1. Main shaft in its stop position.
2. Carriage in center of its travel (in position to print the 36th character of a 72 character line).
3. One of the tabulator stops located so that the tip of the carriage pawl rests on the high point of the stop.

Fig. 5B

(a) To adjust, rotate tabulator latch back or forward about its lower mounting-screw without disturbing the vertical adjustment 3.06. Tighten both of the tabulator-latch mounting-screws. Check adjustment 3.06. If latch must be repositioned to meet requirement 3.06 recheck 3.11.

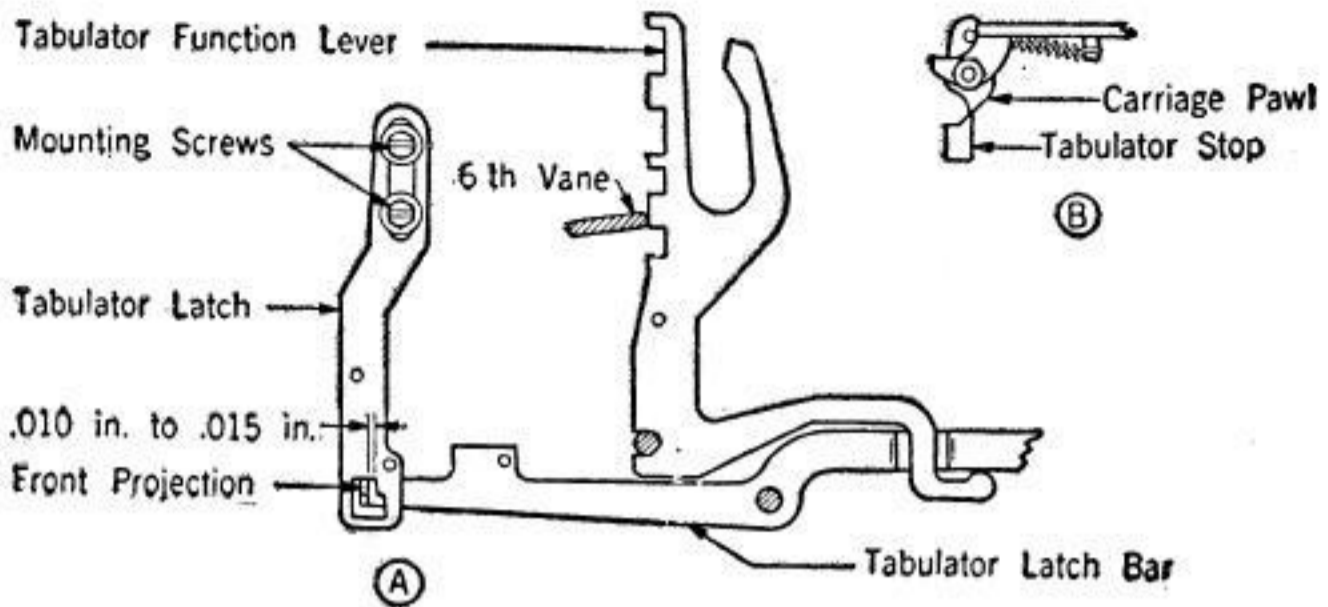

Fig. 5

C. Tabulator Cut-Out

Note: Remove the signal bell and carriage to make the mechanism more easily accessible.

3.13 Spacing Stop-Lever Bracket: The lower end of the spacing stop-lever should clear the driving disc of the main shaft by Min .060", Max .080". With the spacing stop-lever held against the stop on the bracket by means of its spring, there should be a clearance of Min .040", Max .080" between the lower left edge of the stop-lever and the right side of a tooth on the spacing stop-sleeve when the tooth is opposite the lever.

(a) To adjust:

- (1) Move the spacing stop-lever bracket vertically by means of its enlarged mounting-holes to meet the first requirement.
- (2) Move it horizontally to meet the second requirement.
- (3) See that the blocking lever is approximately horizontal, then tighten the bracket screws. See that the blocking-lever extension clears the space pawl-link during this adjustment.

Fig. 2

3.14 Blocking-Lever Extension: Disconnect the tabulator bar spring to prevent latching. With the printing bail in its extreme rear position:

Fig. 2

- (1) Loosen the two screws holding the blocking-lever extension to the blocking lever.

(2) Lower the extension until it rests lightly on the TP86773 space-pawl link. Tighten the screws.

(3) Select the tabulate character.

(4) Manually rotate the main shaft until the printing bail is in its extreme forward position and see that the blocking-lever extension is in its rear (unoperated) position.

(5) Observe the vertical alignment of the front surface of the extension and the link. The front surface of the link should be at least as far forward as the front surface of the extension bracket but should not extend beyond it by more than 1/4 the thickness of the bracket.

To adjust: Add or remove washers between the extension and the blocking lever.

3.15 With the tabulate character selected and the printing bail in its extreme forward position, there should be Min .008", Max .020" clearance between the top of the tabulator latch-bar and the tabulator latch in the unlatched position.

(a) **To adjust:** Loosen the blocking-lever extension screws, raise or lower the extension (keeping it approximately horizontal), and tighten the screws securely. **Fig. 2**

3.16 **Magnet-Bracket Position:** With the magnet energized, the armature and its loosely linked lever should be approximately parallel. Depress the front of the tabulator latch-bar causing the space pawl link to rise. There should be some clearance, not more than .015" at the closest point between the front surface of the forked top of the space pawl link and the rear of the blocking-lever extension. **Figs. 1 & 2**

(a) **To adjust:** Position the TP122364 magnet angle bracket on its mounting-plate and tighten the mounting-screw that does not secure the TP122365 plate. **Fig. 2**

3.17 **Signal-Bell-Hammer Backstop:** With the bell latch-bar in its latched position there should be Min .020", Max .040" clearance between the bell-hammer arm extension and the bell operating-lever.

(a) **To adjust:** Position the TP122365 plate and, in so doing be careful not to shift the magnet angle bracket. Tighten the mounting screw.

3.18 **Long Contact Spring:** With the magnet de-energized, hook a scale behind the insulator on the long contact-spring and pull at right angles to the spring. It should require Min 1 oz, Max 2-1/2 oz to start the contact-spring moving away from the blocking-lever.

(a) **To adjust,** bend the long contact-spring. **Fig. 2+J**

3.19 **Short Contact Spring:** With the magnet de-energized, hook a scale behind the short-contact-spring just above the contact and pull at right angles to the spring. It should require Min 3 oz, Max 6 oz to start the contact-spring moving away from its stiffener. **Fig. 2**

(a) **To adjust,** bend the short-contact spring.

3.20 **Spring Stiffener:** With the magnet energized, there should be at least .003" clearance between the short-contact-spring and its stiffener. With the magnet de-energized there should be a gap of at least .025" between the contacts.

(a) **To adjust,** bend the stiffener.

Note: If the .003" requirement cannot be met, increase the armature travel by shifting the contact-bracket within its elongated mounting holes. **Fig. 2**

3.21 **Spacing Stop-Lever Spring Tension:** With a scale held in a horizontal position and hooked over the upper end of the spacing stop-lever, pull toward the right. It should require Min 8 oz, Max 12 oz to start the lever moving.

3.22 **Blocking-Lever Spring Tension:** Hold the long contact spring away from the blocking lever. Hook the scale on the lever near the spring hole, and pull at right angles to the lever. It should require Min 1 oz, Max 2 oz to start the lever moving. **Fig. 2**

Note: Replace the typebar carriage.

3.23 **Right-Margin Adjusting-Screw:** The typing unit should normally print seventy-two characters on a line before spacing is blocked by the spacing stop-pawl.

(a) To adjust, return the carriage to the left end of the line and back off the right-margin adjusting-screw. Then, with the right-margin adjusting-screw arm in engagement with its detent, space the carriage one less space than the number of characters desired per line, that is seventy-one spaces for normal lines of seventy-two characters. The carriage should then be in position to print the last characters for the desired length of line. Adjust the stop screw so that the spacing stop-lever is moved within Min .015", Max .030" from a projection on the spacing stop-sleeve. ↵

4. SERVICE LINE-UP TESTS

4.01 **General:** In order to start service for a customer using teletypewriters equipped with tabulators it is desirable to use a sample form of the type required by the service and (1) to adjust the left margin, (2) check spacing

clutch performance, (3) set the tabulator stops as specified in the service order, (4) make tests on the line with all stations connected to insure that the teletypewriters at all stations are lined up alike, (5) instruct the attendants at each station in the operating procedures recommended for most satisfactory use of the equipment.

4.02 **Spacing clutch performance** should be checked before any tabulator stops are placed on the tabulator bar except the right end-of-line tabulator stop (one with broad face instead of tip). With all machines on the circuit write a full line of 12345678901234 — — — across the page, send two carriage returns, a line feed and a tabulate signal. While the carriage is in motion and after it has traveled about half-way across the page type a zero and check with each station on the circuit as to the position in which the zero was typed with respect to the line of figures directly above (for example, the zero may appear under the digit 3 of the 4th group). All spacing clutches are in satisfactory condition, if the zero is typed under the same figure of the same group within plus or minus one character on all machines. Check the performance by sending from each station. On those machines which appear to lag behind the sending station (type the test character too far to the left) check the following:

- (a) Type-carriage travel for bind.
- (b) Spacing shaft for bind.
- (c) Spacing-clutch torque.
- (d) Main-shaft clutch and clutch throw-out lever for reliable operation.
- (e) Motor speed.

4.03 **Tabulator stops** should be located on the tabulator bar as follows:

- (a) With the left-hand margin specified in the order, set the tabulator stops in position to type the first character after tabulation at the points specified in the order. Check to see that at least the required number of characters may be typed between stops and at the left and right-hand edges of the form.

Note: If space permits, unused stops may be stored at either the extreme right or left ends of the tabulator bar but care should be used that only **active** stops are counted when interpreting service orders specifying the number and position of stops.

- (b) Each stop should be positioned so that the clearance between the carriage pawl and the stop, with the carriage in position to type the first character of a column,

TABULATOR MECHANISM
TRANSMITTER-DISTRIBUTOR CONTROL
AND TABULATOR CUT-OUT FOR
15 TYPING UNIT
REQUIREMENTS AND PROCEDURES

is equal to the clearance with the carriage in position to type in the space immediately preceding.

(c) Right end-of-line tabulator stop (one with broad face instead of tip) should cam out the tabulator bar when the carriage is at the extreme right end of its travel.

4.04 Send from each station on the circuit in turn and check with all points typing a letter M at each tabulator stop to see that the left edge of the letter is positioned on the form as specified in the service order. Check that the letter does not over-write any of the vertical column lines on the form. Should over-writing occur make the required platen adjustment in accordance with BSP Section P36.619.

Operating Instructions

4.05 After the operation of the mechanism has been checked the cover should be placed on the typing unit. The method of operating the tabulator mechanism should be explained to the attendant. The points listed below should be noted.

4.06 The operation of the tabulator mechanism is similar to that on an ordinary typewriter except that to tabulate it is not necessary to hold the key depressed until the carriage reaches the next stop. Instead the key should be operated and released.

4.07 If it is desired to pass one or more tabulated columns, it is **necessary** to allow the carriage to come to a **full stop** at each of the intermediate tabulator stops and then to operate the tabulator key again. The attendant should be informed that a full stop of the carriage is necessary as there may be a slight difference in speed of carriage travel between the several machines on the circuit due to unavoidable differences in spacing clutch performance in the teletypewriters which may cause the carriage on the local machine to pass the stop as desired while that on the distant machine may not do so if it has not yet reached the corresponding tabulator stop.

4.08 If the machines are 19 teletypewriter sets and are equipped with the TP89992 transmitter distributor control feature the following additional points concerning operation should be explained to the attendant.

4.09 A non-printing, non-spacing function such as LTRS or FIGS, must be perforated in the tape immediately following each tabulator signal so that time is allowed for the control to open the distributor stop magnet circuit and the distributor brushes to reach the stop position so that the next character to be typed will appear in the proper tabulated column.

4.10 In perforating material involving several tabulator stops, particularly copy which is to be typed on forms, it will be desirable to have a teletypewriter arranged to monitor or prove the perforating so that the attendant may be relieved of the necessity for keeping count of the number of tabulating and line feed operations perforated, or the number of characters between tabulator stops.

4.11 Where typing is done on plain paper there is usually no need for line feeding a uniform distance for each message. In this case, if only one or two tabulator stops are used, it may be practicable for the attendant to perforate without a teletypewriter to prove the tape.

4.12 In any case, it is necessary to have a teletypewriter connected to monitor the copy when the transmitter-distributor is sending to the line so that the tabulator is in circuit to control the distributor in accordance with the tabulation operations in the tape.

4.13 To meet the requirements of Paragraphs 4.12 and 4.14 in form-writing machines it is suggested that the forms used be so made up that half of the required number of copies are typed when proving the perforating, the remaining half being typed when the tape is being sent to the line.

4.14 With the tabulating and distributor-control arrangement provided, it is, in general, practicable to simultaneously perforate tape and transmit to the line only under conditions similar to that outlined in Paragraph 4.13 unless two teletypewriters each equipped with a tabulator are used, one to monitor preparation of the tape, the other to monitor the transmission to the line and provide the control for the transmitter distributor. With this arrangement, the speed of preparing tape is limited to the speed of the teletypewriter used to monitor the perforating.