

American Telephone and Telegraph Company

BELL SYSTEM PRACTICES  
Telegraph and Manual  
Telegraph Station and PBX  
Installation and Maintenance

SECTION P35.910  
Issue B, 6-15-53  
Long Lines Department  
Dist. Class. 602.01AC

NO. 14 TRANSMITTER-DISTRIBUTOR

INSTALLATION OF SWITCH TO CONTROL MOTOR CIRCUIT

1. GENERAL

1.01 This section gives information regarding the use of an auxiliary switch on 14-type transmitter-distributors which will permit opening the driving motor circuit independent of the main power switch associated with the teletypewriter equipment of which the transmitter-distributor may be a part. This feature should be provided only when specified on the Service Order.

1.02 This issue supersedes Issue A. This section is reissued to (a) relocate the auxiliary power switch, (b) to make the current physical arrangement A and M, (c) to make it applicable to units made available since the original issue, (d) to incorporate the changes covered in Addendum P35.910, Issue A and to add information involving an auxiliary power switch for transmitter-distributors mounted on XRT205 and XRT206 teletypewriter tables.

1.03 Where the transmitter-distributor is part of a 19-type teletypewriter set mounted on an XRT205 or XRT206 table and a separate switch is desired for it, no modifications will be required in the transmitter-distributor since space is provided in the switch box on the table for the additional switch.

1.04 Where the switch is to be part of the transmitter-distributor, a special mounting detail required to mount the auxiliary switch shall be provided in accordance with information contained in Long Lines Section AB84.903.

1.05 This section was prepared before the TP101481 tape-out (sixth pin) contact assembly was developed and the auxiliary power switch was located in the space now assigned to the contact assembly. Due to the widespread application of this contact assembly it became necessary to relocate the auxiliary power switch.

1.06 The parts required to provide a built-in switch are:

- 1 - Detail per Paragraph 1.03
- 1 - TP107393 toggle switch (or equivalent)
- 2 - TP1160 screws
- 2 - TP2191 lock washers

1.07 The parts required to add a switch to the XRT205 and XRT206 table are:

- 1 - TP81273 or Hubbell 8941 single pole toggle switch

## 2. INSTALLATION INFORMATION

(A) INSTALLATION OF SWITCH ON TRANSMITTER- DISTRIBUTOR (A + M)

2.01 Provide a second switch hole in the snap panel in accordance with Figure 1.

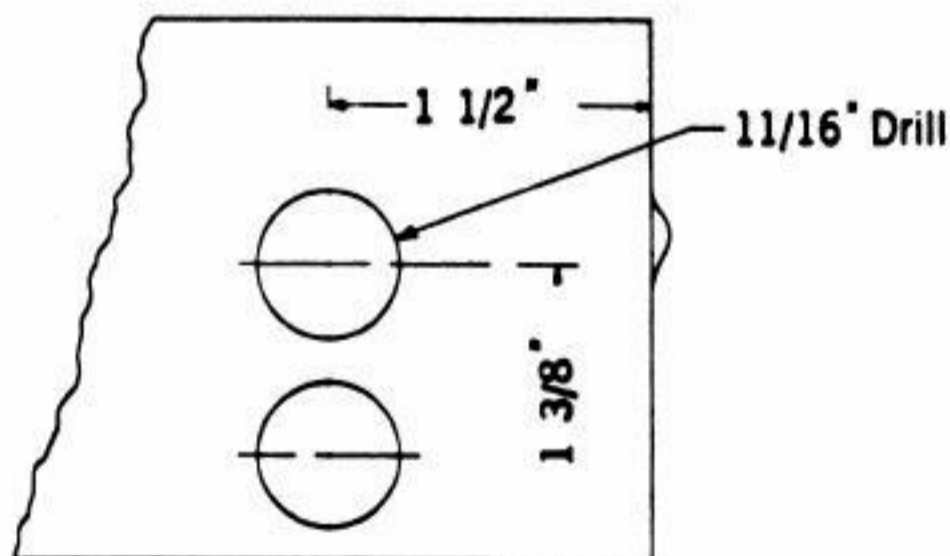

MODIFICATION OF  
TRANSMITTER SNAP PANEL  
FIG. 1 (A & M)

2.02 Install the switch on the special detail which should be mounted on the lever guide, using the two front threaded holes provided for the six-unit transmitter plate and the two TP1160 screw and TP2191 lock washers. See Figure 2.

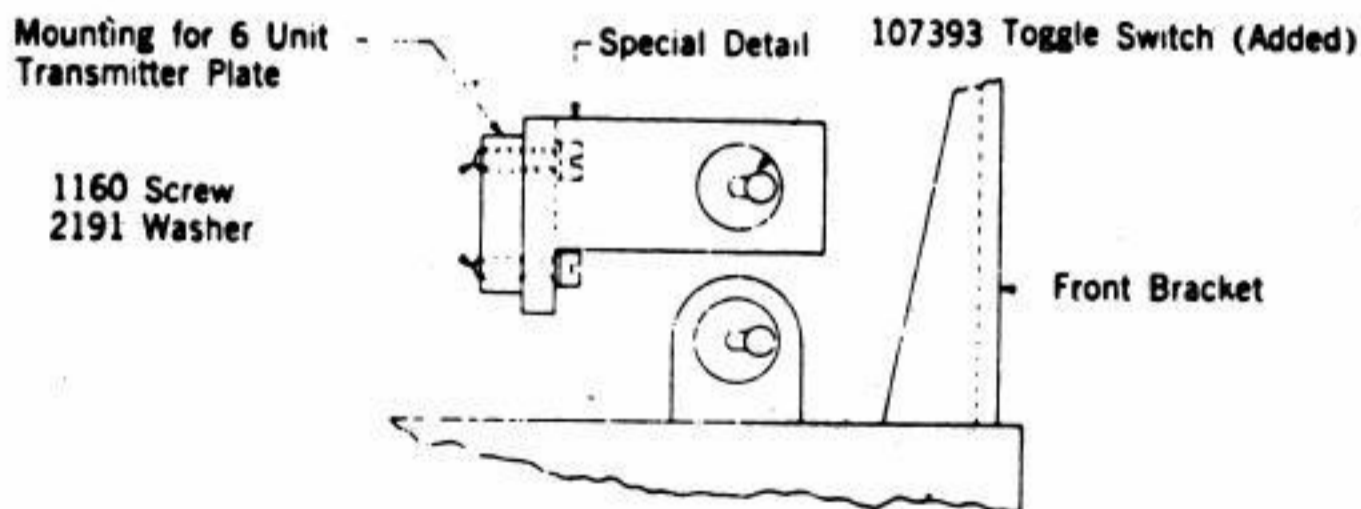

MOUNTING ARRANGEMENT OF  
MOTOR SWITCH DETAIL  
FIG. 2 (A & M)

2.03 Change the connections of the motor power circuit and connect the switch as shown in Figure 3, using the diagram applicable to the particular type of transmitter-distributor being modified. Use No. 18 deltabeston fixture wire for the switch connections.

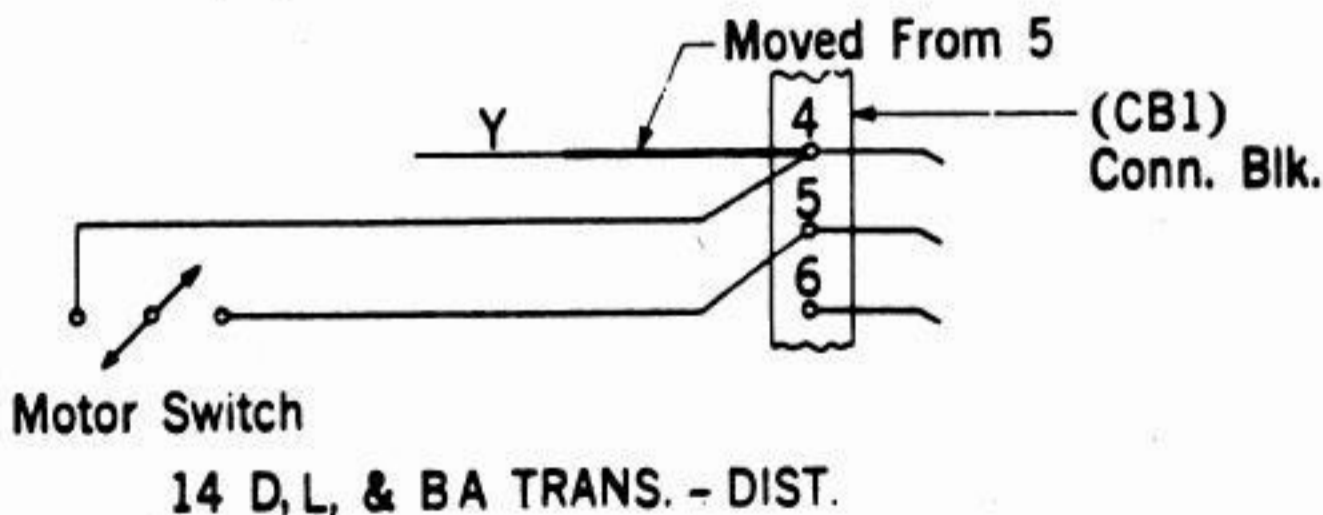
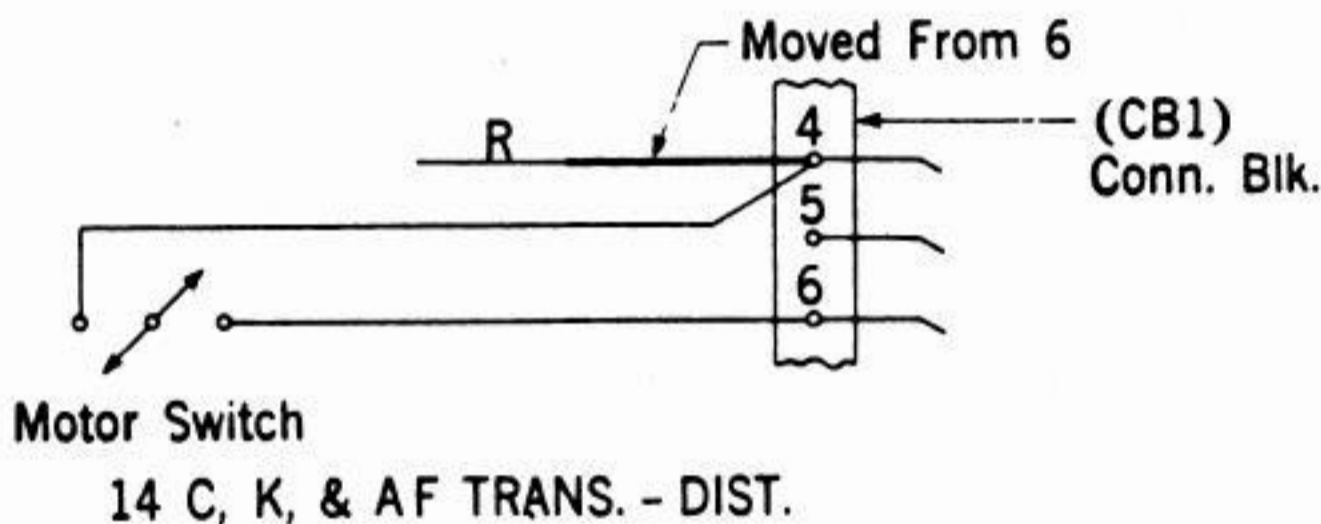
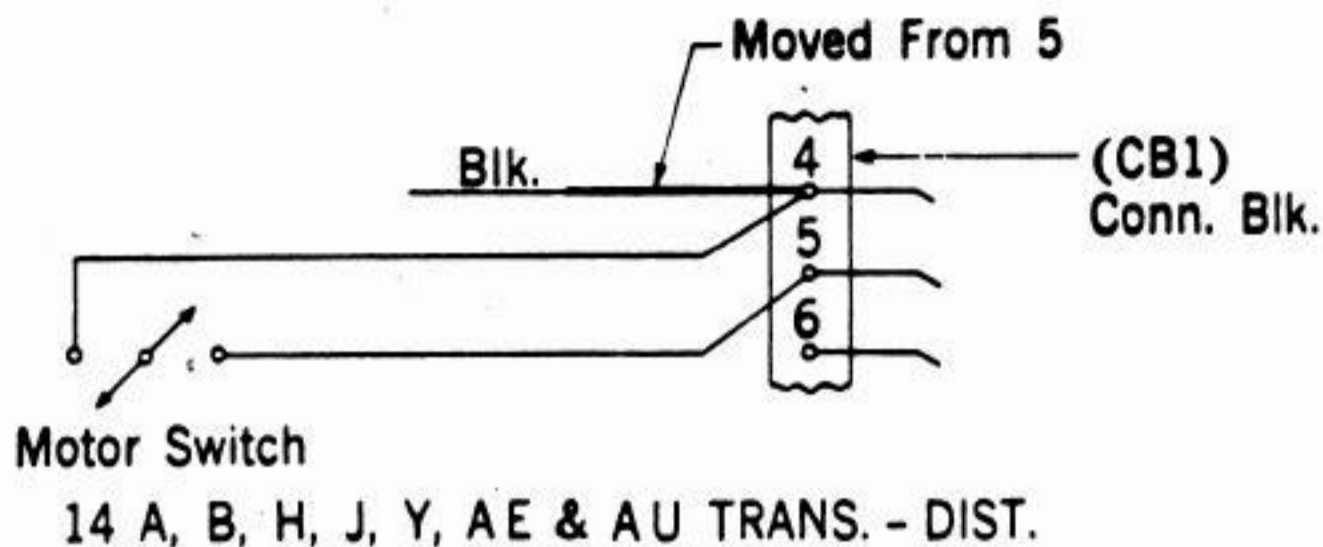

WIRING CONNECTIONS FOR SWITCH CONTROL OF 14 TYPE TRANS. - DIST.

FIG. 3

2.04 The new wires for the switch should be run under the casting, following the course of the connections to the start magnet control switch.

(B) INSTALLATION OF SWITCH ON TRANSMITTER-DISTRIBUTOR (STANDARD)

2.05 Provide a second switch hole in the snap panel in accordance with Figure 1A.

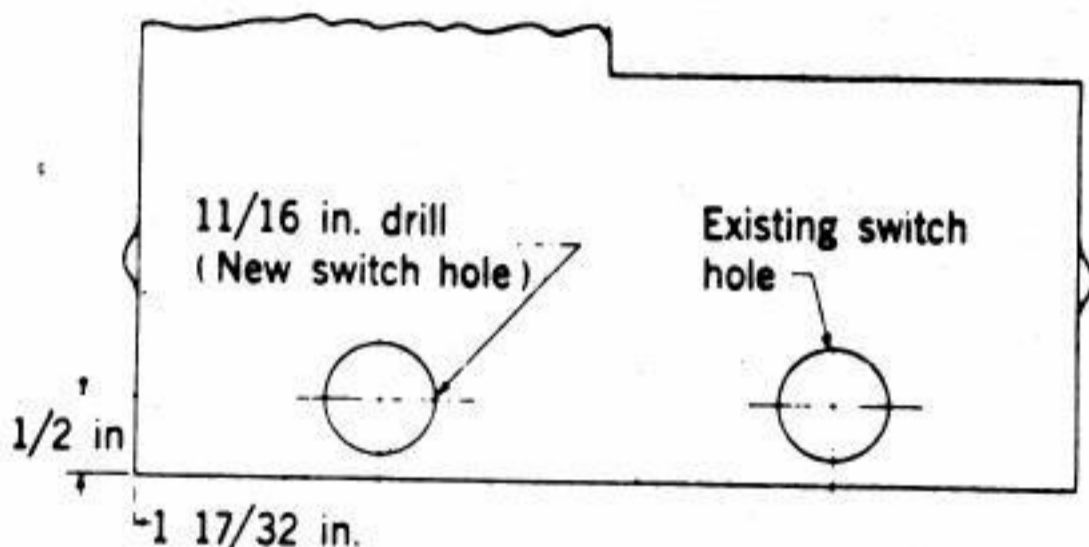

MODIFICATION OF  
TRANSMITTER SNAP PANEL

FIG. 1 A

2.06 Drill and tap two holes for No. 6-40 screws as shown in Figure 2A.

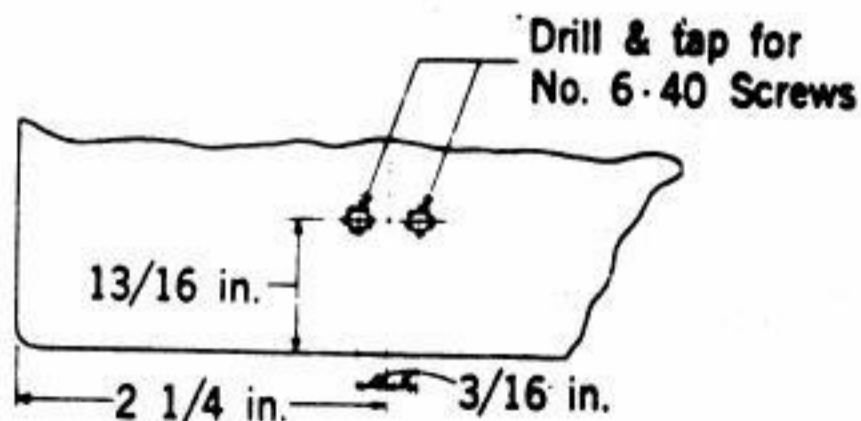

MODIFICATION OF  
TRANSMITTER BASE

FIG. 2 A

2.07 Install the switch on the special detail which should be mounted on the casting using the two holes drilled and tapped per Paragraph 2.06 and the two TP1160 or P-134929 screws and TP2191 lock-washers. See Figure 2B.

Special Detail (Position so That Both Switches are Same Distance From Front Edge)

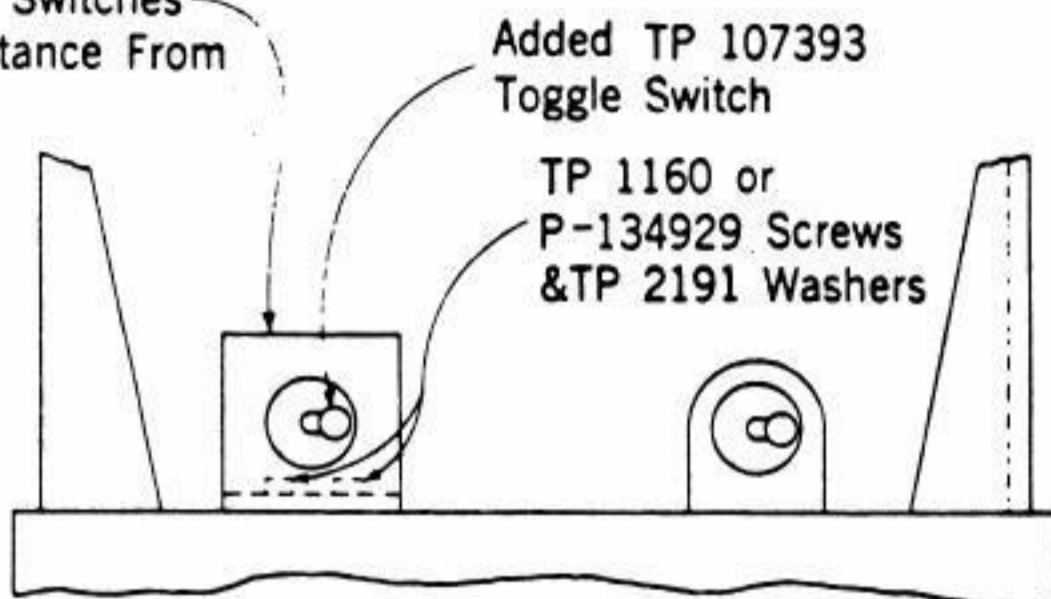

MOUNTING ARRANGEMENT OF  
MOTOR SWITCH DETAIL

FIG 2 B

2.08 Change the connections of the motor power circuit and connect the switch as shown in Figure 3, using the diagram applicable to the particular type of transmitter-distributor being modified. Use No. 18 deltabeston fixture wire for the switch connections.

2.09 The new wires for the switch should be run under the casting, following the course of the connections to the start magnet control switch. If desired the two wires shown connected to Terminal 4 may be spliced, taped and sewn into the cable.

(C) INSTALLATION OF SWITCH IN THE XRT205 AND  
XRT 206 TABLES

2.10 Cut the loop in position G in the switch box containing the table switch which controls all the power to the table and connect the two ends to the new switch.

2.11 Install the new switch in the space provided for it to the left of the table switch.

3. OPERATING INFORMATION

3.01 In order to avoid the possibility of having the transmitter brush arm stop on an open segment when the motor is stopped by the auxiliary switch, the following operations should be performed in the sequence shown:

When it is desired to stop the transmitter-distributor:

FIRST - Operate to the OFF position the switch controlling the start magnet

SECOND - Operate to the OFF position the auxiliary switch controlling the motor

Conversely, when it is desired to start the transmitter-distributor

FIRST - Operate to the ON position the auxiliary switch controlling the motor

SECOND - Operate to the ON position the switch controlling the start magnet

3.02 When both the transmitter start switch and the auxiliary motor switch are in the ON position, the normal operation practices for the installation may be followed.

4. REFERENCE

4.01 Figures 1 to 3 inclusive, are reproduced from Long Lines Drawing S-831C-143, Sheet 1.

Figures 1A, 2A and 2B are reproduced from Long Lines Drawing S-831C-143, Sheet 2.