

BELL SYSTEM PRACTICES
Teletypewriter Stations

SECTION P33.020
Issue 1, September, 1953
AT&T Co Standard

ON-LINE WORD COUNTER

WM200 TYPE

Table of Contents	Page
1. GENERAL	1
2. DESCRIPTION	1
3. THEORY OF OPERATION	2
4. REQUIREMENTS AND PROCEDURES	3
5. LUBRICATION	6
Mechanical Word Counter and Electrical Word Counter	
Installation	See P36.475
Requirements and Procedures	See P36.615

1. GENERAL

1.01 This section contains a description and maintenance information for the on-line word counter. Unlike earlier types of word counters which require close physical association with the teletypewriter, this counter connects in series with the loop circuit and counts the words transmitted over the circuit. Six 5-unit code combinations are counted as one word.

2. DESCRIPTION

2.01 Two word counters are available, one for 60 words per minute and the other for 75 words per minute, the only difference being in the gears. A word counter for operation at one speed may be converted to the other speed by changing gears as follows:

To Convert To

	<u>60-speed</u>	<u>75-speed</u>
Gear	TP122408	TP122424
Gear	TP122410	TP122425
Nameplate	TP106380	TP106380
	(Stamped WM200 AB60)	(Stamped WM200 AB75)

2.02 The counter is designed to operate on a start-stop basis in a .060-ampere neutral telegraph loop carrying 5-unit code signals. Special arrangements would be required for a .020-ampere loop or for polar signals. The counter is driven by a small 110-volt 60-cycle synchronous motor through gears and an escapement mechanism controlled by a magnet similar to a selector magnet which responds to the teletypewriter signals passing through it. It counts up to 99,999 words and may be reset manually to zero from any point.

2.03 If the motor is run from an unregulated 60-cycle power source, some errors in counting may be expected. They will depend on the variation in the power frequency and the distortion in the signal circuit.

2.04 The counter is 5-1/2 inches wide, 5-3/4 inches deep and 5-7/8 inches high, including the small mechanical counter unit which projects from the front about 1-7/16 inches. The cover of each unit has three depressions spaced to match the spacing of the feet so that one unit may be placed on top of another. If the feet are removed, the unit may be fastened to a horizontal surface. It is not arranged to mount on a vertical surface.

2.05 The word counter is equipped with a terminal block for the power and line connections. For convenient and flexible use it may be wired to jacks so that it can be patched to any one of a group of circuits. It is not necessary to locate the counter near the teletypewriter, since only the loop circuit and ac power are required for the operation of the mechanism.

2.06 Fig. 1 shows the wiring diagram. **Fig. 1**

2.07 Teletype Corporation Bulletin 1152B lists the parts of the word counter.

3. THEORY OF OPERATION

3.01 Fig. 2 shows the main-shaft assembly and Fig. 3 the motor with mounting and gearing to the main-shaft gear. **Figs. 2, 3**

3.02 The counting operation is controlled by the interaction of the escapement (ratchet) wheel, shown in Fig. 4, with the extension of the armature of the selector magnet. This extension is bifurcated (See Fig. 6) to form a marking stop-arm and a spacing stop-arm. The ratchet wheel has six stop-lugs, which are held or released by the stop-arms. The speed of rotation of the wheel is such that each lug corresponds to a single character and a complete revolution of the wheel, which registers one on the counter, to a word. **Figs. 4, 6**

3.03 Under the normal closed line condition (marking), the ratchet wheel is stopped by the engagement of one of its lugs with the marking stop-arm of the armature extension as shown in Fig. 6. The start element (spacing) of a character releases the armature, which moves to its spacing position. The stop-lug passes through the slot in the armature extension (Fig. 5) and the wheel turns freely, regardless of whether the signal elements are marks or spaces, until the next stop-lug approaches the armature extension. At that time the magnet is energized by the stop element of the signal and the marking stop-arm blocks the lug and stops the wheel. (Fig. 6) When the next start element is received, the process is repeated, the mechanism moving $1/6$ of a word count for each stop. **Figs. 5, 6**

3.04 The spacing stop-arm of the armature extension is not normally used. This arm has a yield-spring stop, bowed away from the arm as shown in Fig. 7. If a long break signal is sent or if the line goes open, so that the armature remains in the spacing position, a stop-lug on the wheel comes up to the spring, pushes it against the solid portion of the spacing stop-arm and stops rotation of the wheel. (Fig. 8) The spring closes the spacing side of the slot in the armature extension so that the stop-lug cannot pass through as it did in normal operation. **Figs. 7, 8**

3.05 When line current is restored, the armature is drawn to the magnet and the spacing stop-arm, with spring, is moved out of the way of the stop-lug. The wheel does not turn, however, because the stop-lug is immediately blocked by the marking stop-arm, where it rests in readiness for the next start element. (Fig. 6) In the meantime, the bowed spring moves back out of the way so that it will not interfere with the next movement of the armature to spacing. (Fig. 7) On the next start element, the slot is free and the wheel can turn. **Figs. 6, 7**

3.06 The ratio of the gears between the motor and the main-shaft of the counter is such that for 60-speed operation, the ratchet wheel turns at about 70 rpm, and for 75-speed, at about $87\frac{1}{2}$ rpm. This is one-sixth of the speed of the receiving shaft of the teletypewriter.

4. REQUIREMENTS AND PROCEDURES

4.01 The requirements and adjusting procedures for the maintenance of the word counter are arranged in a sequence that should be followed for a complete readjustment of a unit.

4.02 The motor has built-in speed-reduction gears. Do not attempt to turn it rapidly by hand. When moving or tightening parts, make sure that the ratchet-wheel stop-lugs are clear of the armature-extension stop-arms.

4.03 **Ratchet-Wheel:** Loosen the motor-gear-hub set-screw and remove the gear and hub assembly. The main shaft should rotate freely with less than .002" end-play.

(a) To adjust, position the ratchet wheel with its set-screw loosened. If necessary, disconnect the counter as follows: With the motor shut off and the ratchet-wheel stop-lugs held clear of the stop-arms, hold the shaft with a wrench on the flat surface of the clutch member and remove the hex cap nut and attached drive-spring. **Fig. 2**

4.04 **Drive-Spring:** The drive-spring should grip both shafts with the hook end engaging the notch in the hex cap nut on the main shaft and the other end at least five turns on the counter shaft.

(a) To adjust, remove the counter mounting-screws, remove the hex cap nut, and remove the counter with hex cap nut and drive-spring still attached. To increase or decrease the number of turns of the drive-spring on the counter shaft, hold the counter shaft and rotate the spring in a direction to loosen its coils while pushing or pulling at the same time. Replace the hex cap nut, with attached drive-spring and counter, on the main shaft. Replace the counter mounting-screws. **Fig. 2**

4.05 **Counter:** The counter shaft should turn freely and align with the main shaft.

(a) To adjust, position the counter in its oversize mounting-holes with the mounting-screws loosened. **Fig. 2**

4.06 **Motor:** The motor gear and the main-shaft gear should engage for at least 3/4 their thickness when the motor-shaft end-play is taken up in each of two directions. The gears should rotate freely with minimum backlash.

(a) To adjust, position the motor gear and hub assembly with its set-screw loosened to meet the first requirement and position the motor by means of its oversize mounting-holes to meet the second requirement. **Fig. 3**

4.07 **Clutch Torque:** The clutch torque should be measured after the motor has been running at least ten minutes with the ratchet wheel stationary. Hook a scale under a stop-lug on the ratchet wheel and pull vertically in a direction to cause reverse rotation of the wheel. It should require Min 3-1/4, Max 4-1/4 oz to just start the ratchet wheel moving. The motor should be turned off before making the adjustment.

(a) To adjust, position the torque-adjusting nut with the locknut loosened (left-hand thread) being careful not to jam the stop-lugs of the ratchet wheel against the stop-arms of the armature extension. Tighten the locknut with similar caution. **Fig. 4**

4.08 **Spacing-Bumper-Screw:**—Preliminary—With the armature against the spacing bumper, the stop-lugs on the ratchet wheel should pass through the slot in the armature extension with at least .002" clearance on each side.

(a) To adjust, position the spacing bumper screw with its locknut loosened. **Fig. 5**

4.09 **Armature-Spring:**—Preliminary—With the stop-lugs on the ratchet wheel clear of the armature extension stop-arms, apply the push-end of a scale to the upper armature mounting-screw and push horizontally. It should require Min 1-1/4 oz, Max 1-1/2 oz to just start the armature moving away from the spacing bumper.

(a) To adjust, position the armature-spring adjusting-screw with its locknut loosened. Recheck 4.08. **Fig. 5**

4.10 **Marking-Bumper-Screw:** — Preliminary — With the motor running and the armature operated slowly by hand, the ratchet wheel should escape from the yield spring of the spacing stop-arm of the armature extension just before the armature strikes the marking bumper. **Fig. 6**

(a) To adjust, position the marking-bumper screw with its locknut loosened.

4.11 **Armature:** The armature should pivot freely on its pivot screws with a minimum amount of end-play. The marking stop-arm of the armature extension should meet a stop-lug on the armature squarely and stop it in a vertical position.

(a) To adjust, position the armature by means of its pivot screws to meet the first requirement and position the armature extension by means of its oversize mounting-holes to meet the second requirement. If necessary, reposition the entire magnet assembly by means of the oversize holes in its base plate. **Fig. 7**

4.12 **Spacing-Bumper-Screw:**—Final—With the motor running and the armature manually operated to the marking position, place a .002" gauge between the armature and the spacing bumper and release the armature. The yield spring on the spacing arm of the armature extension should stop all stop-lugs on the ratchet wheel and still meet the preliminary requirement.

- (a) To adjust, refine the spacing bumper screw position and use a .003" gauge in place of a .002" gauge between the armature and the spacing bumper. **Fig. 8**

4.13 Magnet Bracket: With the motor turned off and the selector magnet steadily energized, the armature should clear both magnet cores by at least .002" and should be approximately equally distant from them.

- (a) To adjust, position the magnet bracket by means of its oversize mounting-holes. See that the cores do not extend beyond either end of the armature. **Fig. 9**

4.14 Marking-Bumper-Screw:—Final—With the motor running and the magnet energized, the ratchet wheel will be stopped by the marking stop-arm. When the ratchet wheel is backed up manually it should clear the yield spring on the spacing arm of the armature extension.

- (a) To adjust, refine the marking bumper-screw position. Recheck the magnet bracket position. **Figs. 6 & 9**

4.15 Armature Spring:—Final—Connect the word counter into a .060-ampere loop containing a variable resistor and send an undistorted test message to the unit. The counter should operate without error while the line current is being reduced to .048 ampere and should fail before the line current is reduced to .035 ampere.

- (a) To adjust, refine the armature spring tension. **Fig. 5**

5. LUBRICATION

5.01 Oil the points listed in the following except where grease is specified:

- (1) Motor oil-holes (2). Motor oil-holes in upright position—5 drops each hole.
- (2) Motor-shaft bearing at gear end.
- (3) Counter-shaft bearings (2).
- (4) Main-shaft bearing (each end).
- (5) Armature pivot-screws (2).
- (6) Clutch felt-washers—saturate.
- (7) Gear teeth—light film of grease.
- (8) Armature-extension blocking arms—oil—grease—oil on blocking surface.
- (9) Main shaft. Hold ratchet-wheel stop-lugs clear of blocking arms and remove knurled cap nut (left-hand thread) from rear of main shaft. Remove felt wick from shaft and saturate. Reinsert wick and tighten cap nut with

fingers only. A rubber ring inside the cap nut provides locking and sealing action.

(10) Counter. The counter requires lubrication very infrequently. When necessary, remove the counter and its cover and lubricate as follows:

(a) Wheel bearings—oil sparingly.

(b) Gears—oil—grease.

(11) Drive-spring does not require lubrication.

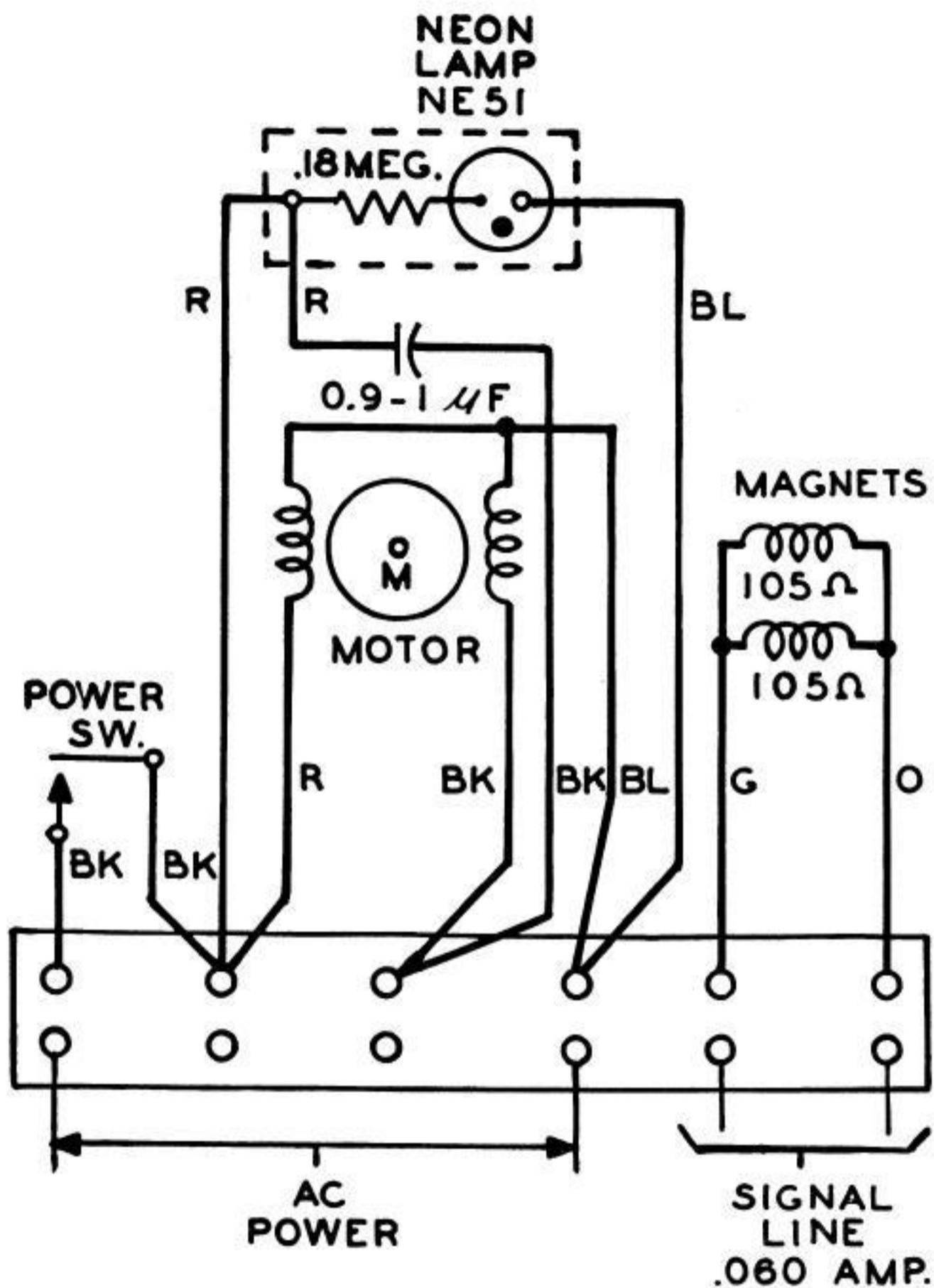

Fig. 1

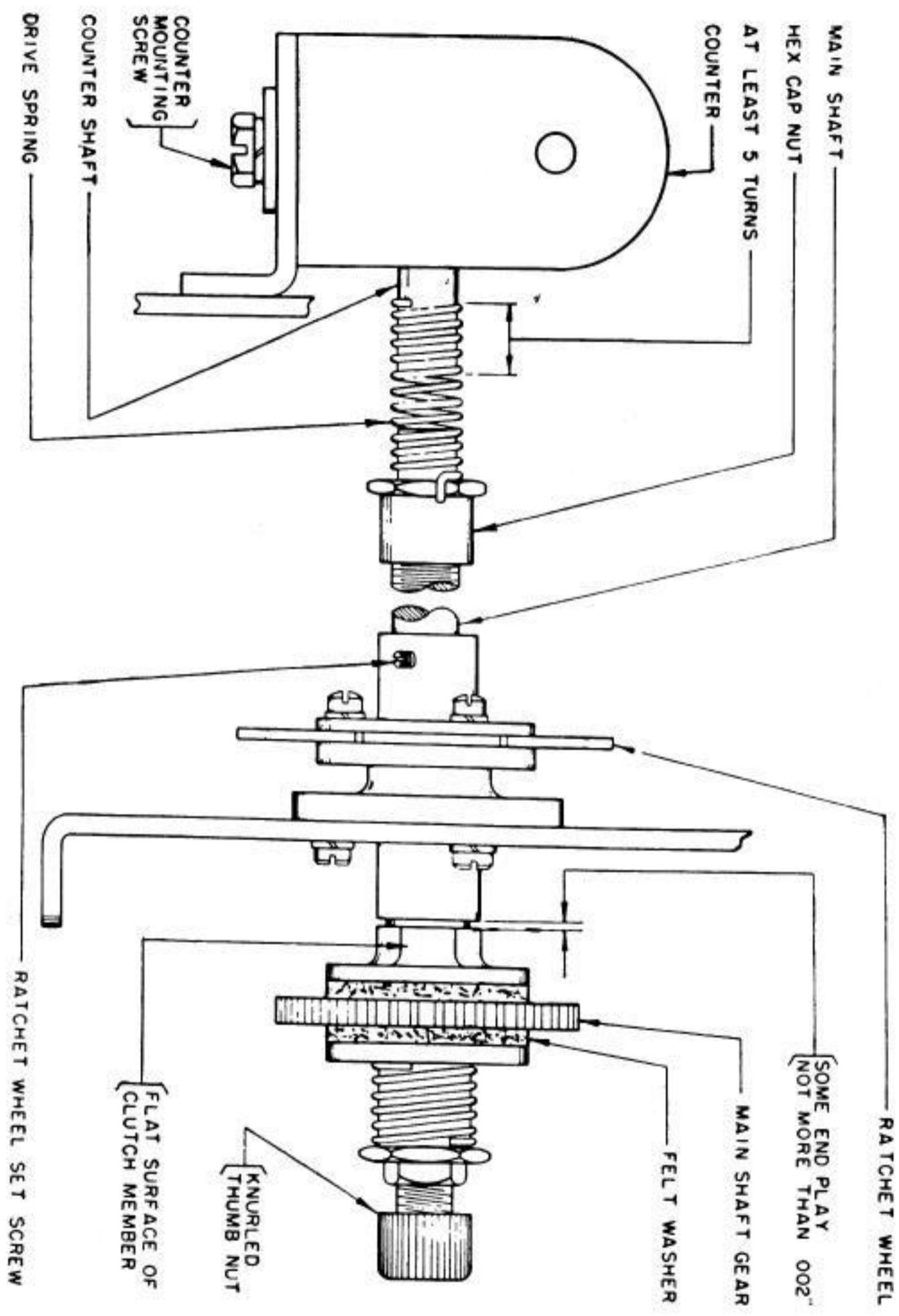

Fig. 2

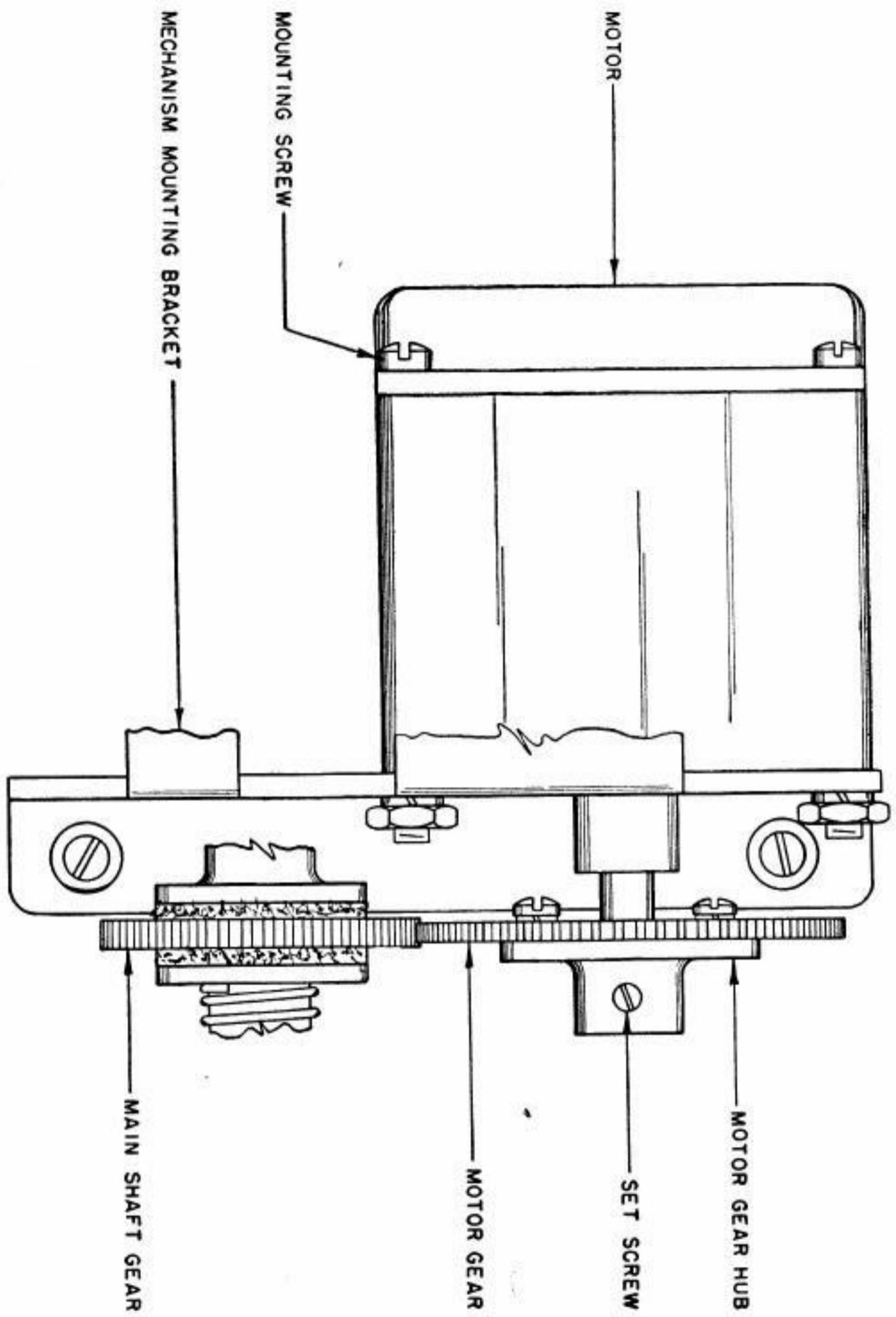

Fig. 3

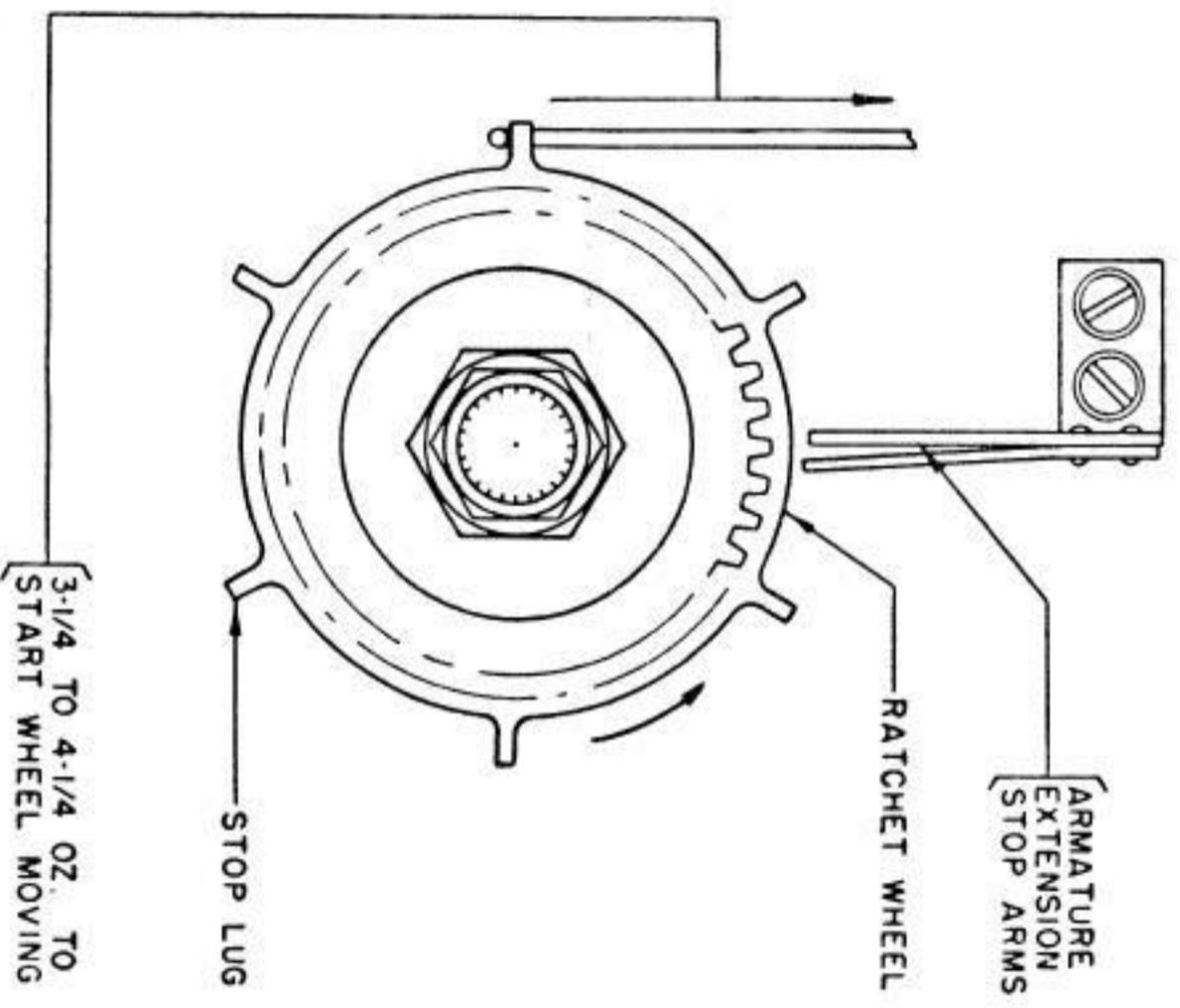
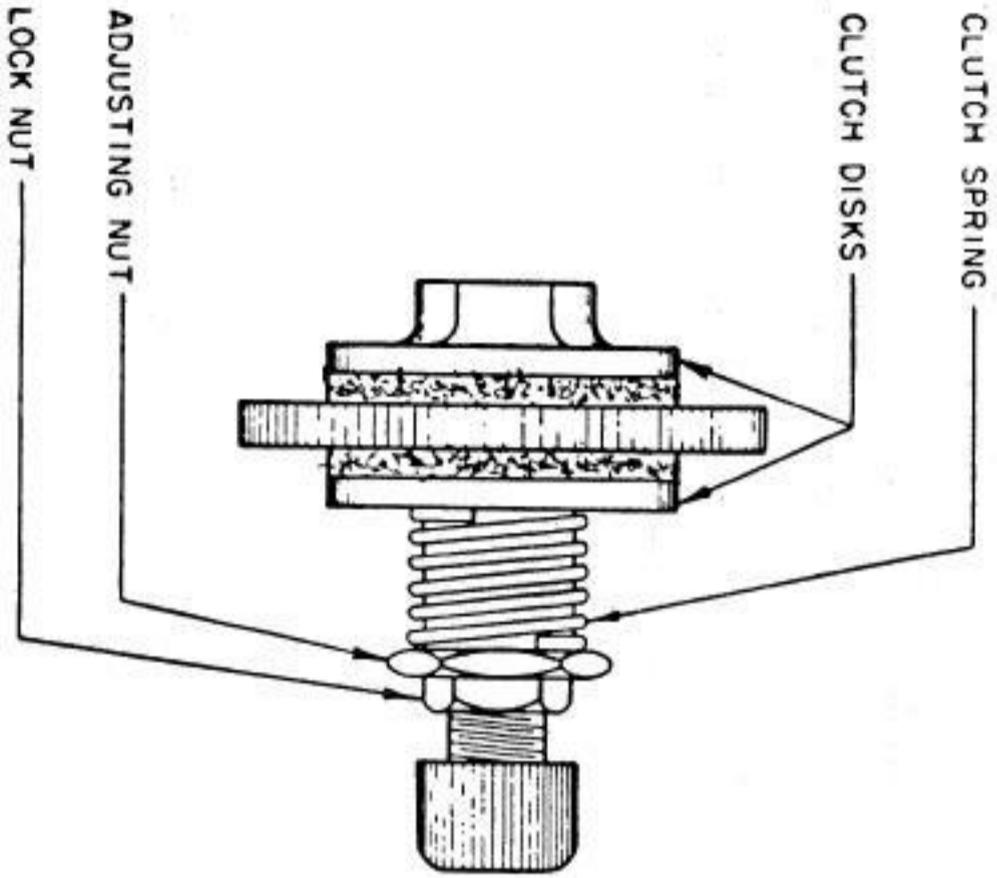

Fig. 4

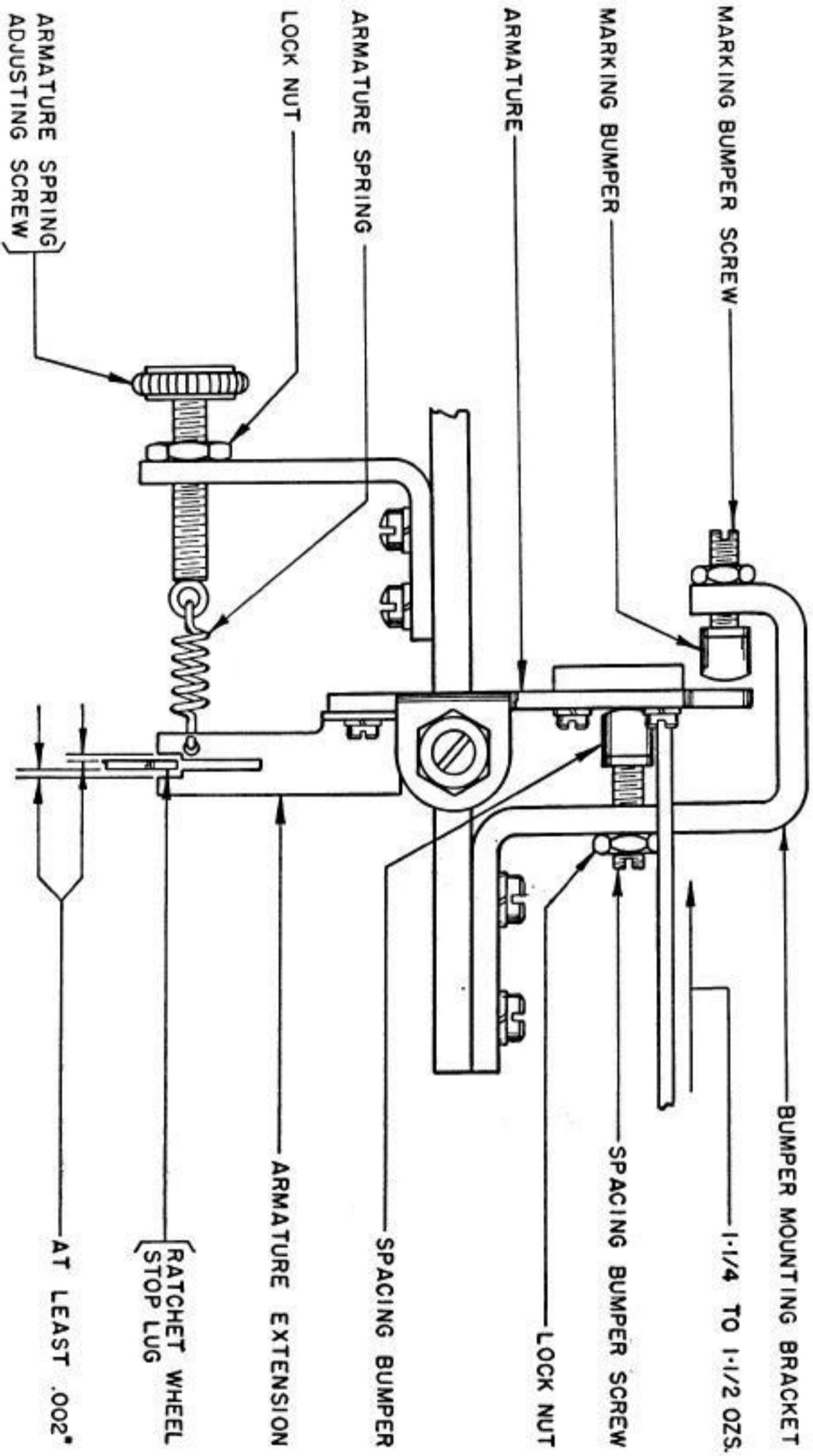

Fig. 5

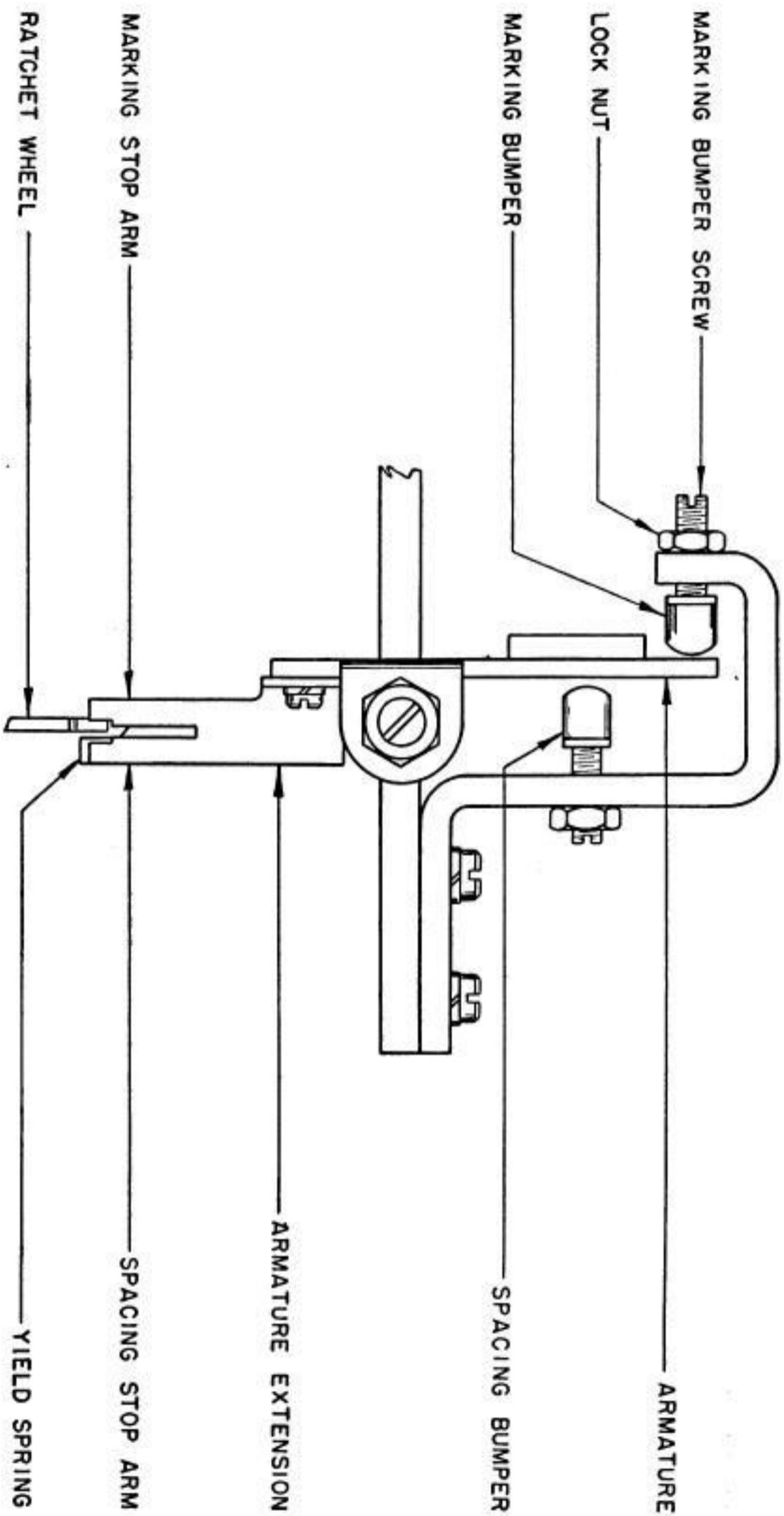

Fig. 6

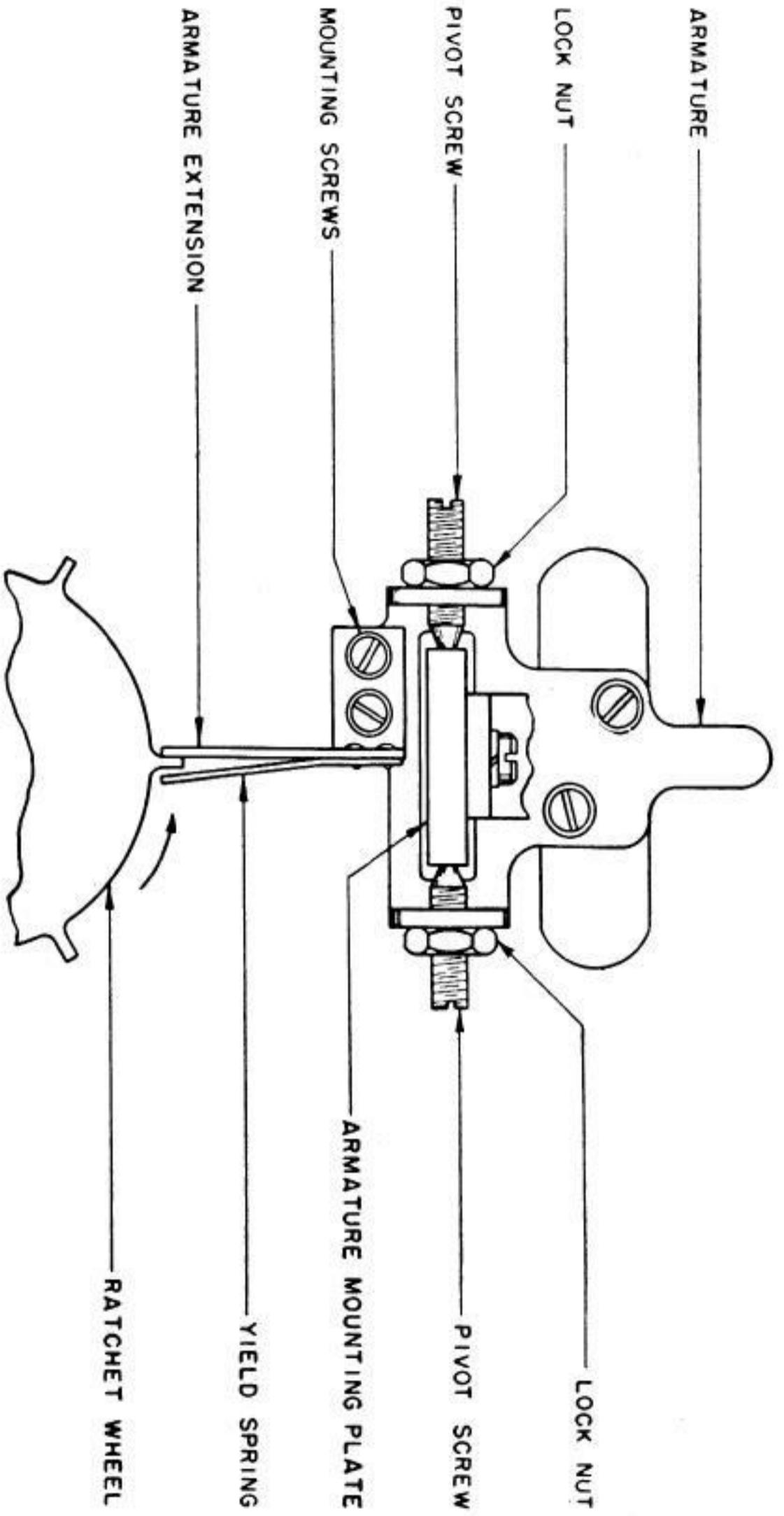

Fig. 7

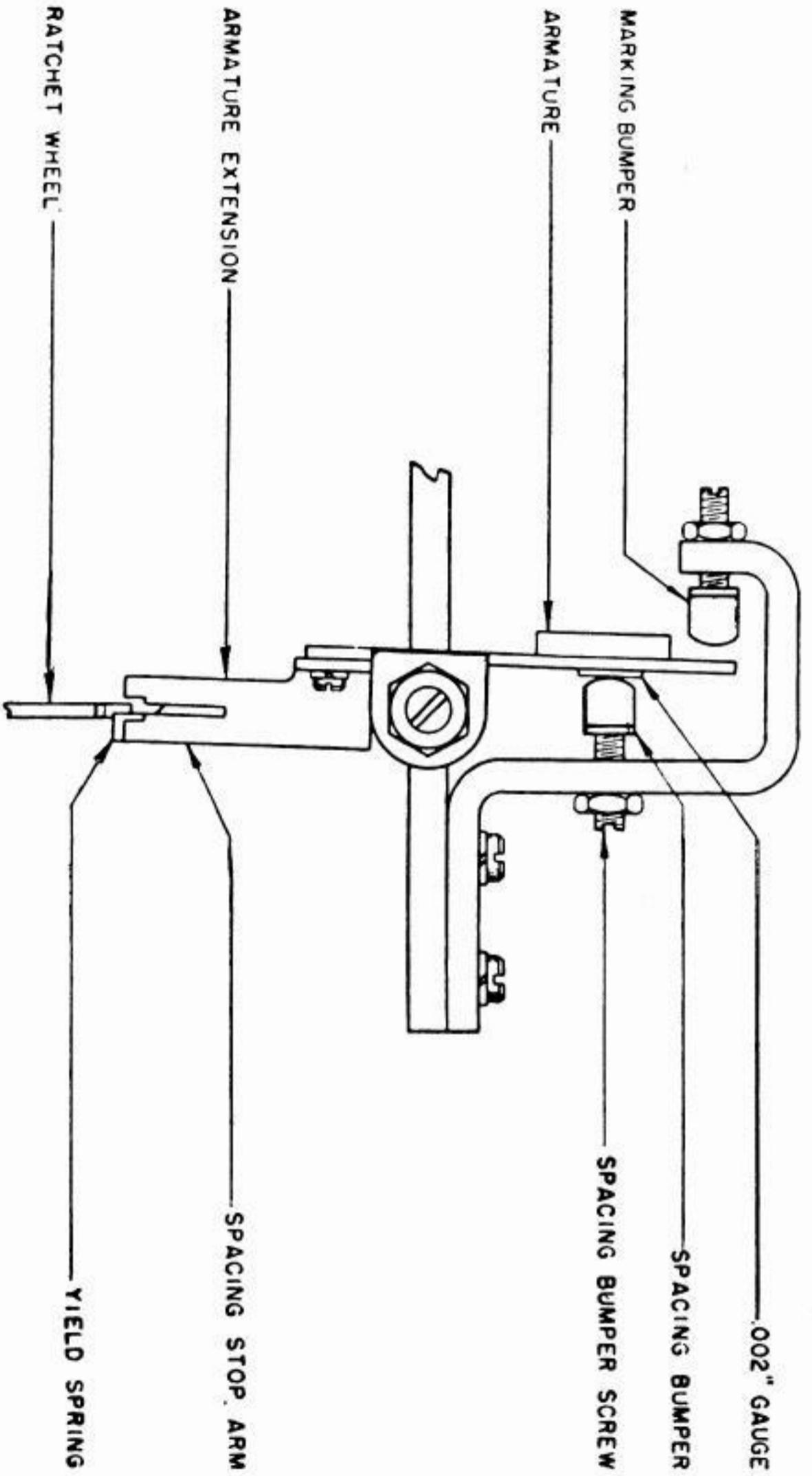

Fig. 8

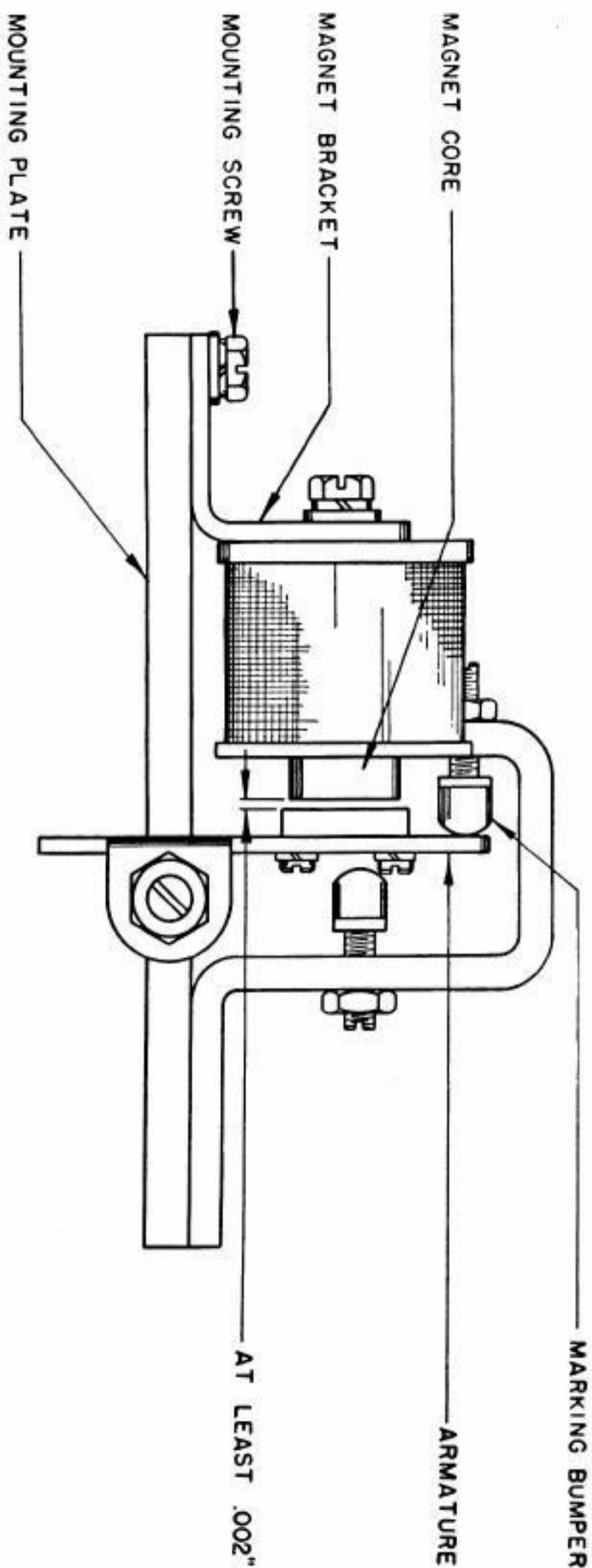

Fig. 9