

TECHNICAL MANUAL
No. 11-5815-206-35
TECHNICAL ORDER
No. 31W4-2PGC1-32

*TM 11-5815-206-35/TO 31W4-2PGC1-32

DEPARTMENTS OF THE ARMY
AND THE AIR FORCE

WASHINGTON 25, D. C., 24 August 1959

TELETYPEWRITER SET AN/PGC-1 AND TELETYPEWRITER TT-4A/TG AND TT-4B/TG

	Paragraph	Page
CHAPTER 1. INTRODUCTION	1-2	2
2. THEORY		
Section I. General	3-8	4
II. Theory of keyboard-transmitter	9-15	8
III. Theory of page printer	16-33	14
IV. Circuits of teletypewriters TT-4A/TG and TT-4B/TG	34-37	47
CHAPTER 3. MAINTENANCE INSTRUCTIONS		
Section I. General	38-41	54
II. Preventive maintenance	42-45	55
III. Lubrication	46-50	59
IV. Troubleshooting	51-55	71
V. Removal and replacement of teletypewriter components	56-65	76
VI. Disassembly and reassembly of teletypewriter components	66-133	82
VII. Teletypewriter adjustment procedures	134-275	171
VIII. Spring data	276-280	231
CHAPTER 4. FINAL TESTING	281-287	237
APPENDIX. REFERENCES		240
GLOSSARY.		241
INDEX.		242

This manual, together with TM 11-5815-206-12, 8 April 1959 supersedes TM 11-2234, 6 April 1951, including C 1, 19 October 1953; C 2, 23 November 1955; and C 3, 11 October 1957.

CHAPTER 1

INTRODUCTION

1. Scope

a. This manual covers field and depot maintenance of Teletypewriter Set AN/PGC-1 and Teletypewriters TT-4A/TG and TT-4B/TG. It includes instructions appropriate to third, fourth, and fifth echelons for troubleshooting, repairing, adjusting, and testing the equipment. It also lists tools, materials, and test equipment required for these echelons of maintenance. Detailed functioning of the equipment is covered in the theory chapter.

b. The complete instructions for this equipment include the information in this manual and the information in TM 11-5815-206-12.

c. The maintenance allocation chart is contained in appendix II, TM 11-5815-206-12.

d. Forward all comments concerning this manual to: Commanding Officer, U.S. Army Signal Publications Agency, Fort Monmouth, N. J.

Note. For applicable forms and records, see paragraph 2, TM 11-5815-206-12.

2. Internal Differences in Models

Internal differences in models which affect field and depot maintenance are described in the table below. Differences that affect operation and first and second echelon maintenance of the equipment are covered in TM 11-5815-206-12.

Item	Teletypewriter TT-4A/TC	Teletypewriter TT-4B/TG
Transmitter filter	Two-path filter (fig. 58).....	Three-path transmitter filter (fig. 59).
Shaft bearing mounts	Screws and washers used to hold bearings in main frame assembly (fig. 117).	Bearing caps used to hold bearings in main frame assembly (fig. 118).
Friction clutches	Include solid friction-adjusting collar (B, fig. 10).	Include split friction-adjusting collar (A, fig. 10).
Carriage-feed and carriage-return blocking lever adjustment.	Adjusting stud used to adjust carriage-feed and carriage-return blocking levers (fig. 38).	Carriage-return blocking adjusting collar and carriage-feed blocking adjusting plate used to adjust carriage-feed and carriage-return blocking levers (fig. 37).
Transfer-lever-spring post	Nonadjustable	Eccentric spring post adjustable (fig. 157).
Code-ring cage assembly.....	Does not include adjustable function stop-bar fulcrums or code-ring locking-bail mechanism (fig. 106).	Includes adjustable function stop-bar fulcrums and code-ring locking-bail mechanism (fig. 107).
Method of holding Y-levers in selected position.	Friction plates used (fig. 93).....	Y-lever detents and springs used (fig. 94).
Device for stabilizing relationship of Y-lever pivot stud and Y-lever eccentric stop.	Not included	Eccentric tie, stud bracket, and spacer used (25, 26, and 27, fig. 94).

Item	Teletypewriter TT-4A/TG	Teletypewriter TT-4B/TG
Platen figures-shift blocking mechanism.	Not included	Platen lower-case latch, platen-blocking arm, and platen-blocking arm bracket included to prevent accidental shift of platen to figures-shift position (fig. 41).
Platen and paper trough assembly.....	Includes six pressure rollers (fig. 83).	Includes only one pressure roller and new pressure release mechanism (fig. 84).
Keylever locking bar.....	Not included	Included to hold keylevers in keylever mounting bracket (fig. 77).
Rangefinder orientation lever.....	Does not include machine screw for adjustment (10, fig. 92).	Includes machine screw for adjustment (6, 7, and 11, fig. 92).
Line-feed mechanism.....	Includes one-piece line-feed bell crank (17, fig. 99); includes one-piece platen-shift link (26, fig. 99).	Includes adjustable two-piece line-feed bell crank (18 and 19, fig. 100); includes three-piece shock-absorbing platen-shift link (25, fig. 100).
Ribbon-lifter assembly.....	Adjusted by rotating turnbuckle (fig. 52).	Adjusted by repositioning adjusting links (fig. 53).
Dust cover.....	10¼ in. high.	10⅞ in. high.
Immersion-proof cover.....	10½ in. high.	10⅞ in. high.
Method of securing page printer to teletypewriter base.	Nut, lockwasher, and mounting screw in shock mounts used (1, 2, and 3, fig. 126 and 14, fig. 128).	Machine screw, washers, and hole through mounting stud used (fig. 74).
Motor mounting.....	Machine screws, lock washers, and shims used (1, 2, and 3, fig. 81).	Machine screws, washers, and adjustable sleeves used (4 through 7, fig. 81).
Motor-stop relay assembly.....	Includes two-bladed armature that controls exposed contacts (fig. 55 and 56).	Includes single-bladed armature that operates sealed switches (fig. 53 and 54).

CHAPTER 2 THEORY

Section 1. GENERAL

3. Basic Teletypewriter Theory (fig. 1)

The major subdivisions of Teletypewriter TT-4(*)/TG are the keyboard-transmitter, the page printer, and the motor.

a. Keyboard-Transmitter. Transmission of teletypewriter messages occurs when a teletypewriter operator presses the keys of the keyboard-transmitter. The transmitter contacts open and close the signal circuit to transmit intelligence in the form of teletypewriter code groups (par. 4).

b. Page Printer. Operation of the page printer is controlled by teletypewriter code groups which are received by the coils of the selector magnet. Each code group starts a cycle of mechanical operation in the page printer that results either in the printing of a character or in the accomplishment of a nonprinting mechanical operation such as the moving of the platen to the figures-shift position for the printing of upper-case symbols.

c. Motor. The motor supplies mechanical power for operation of the keyboard-transmitter and the page printer.

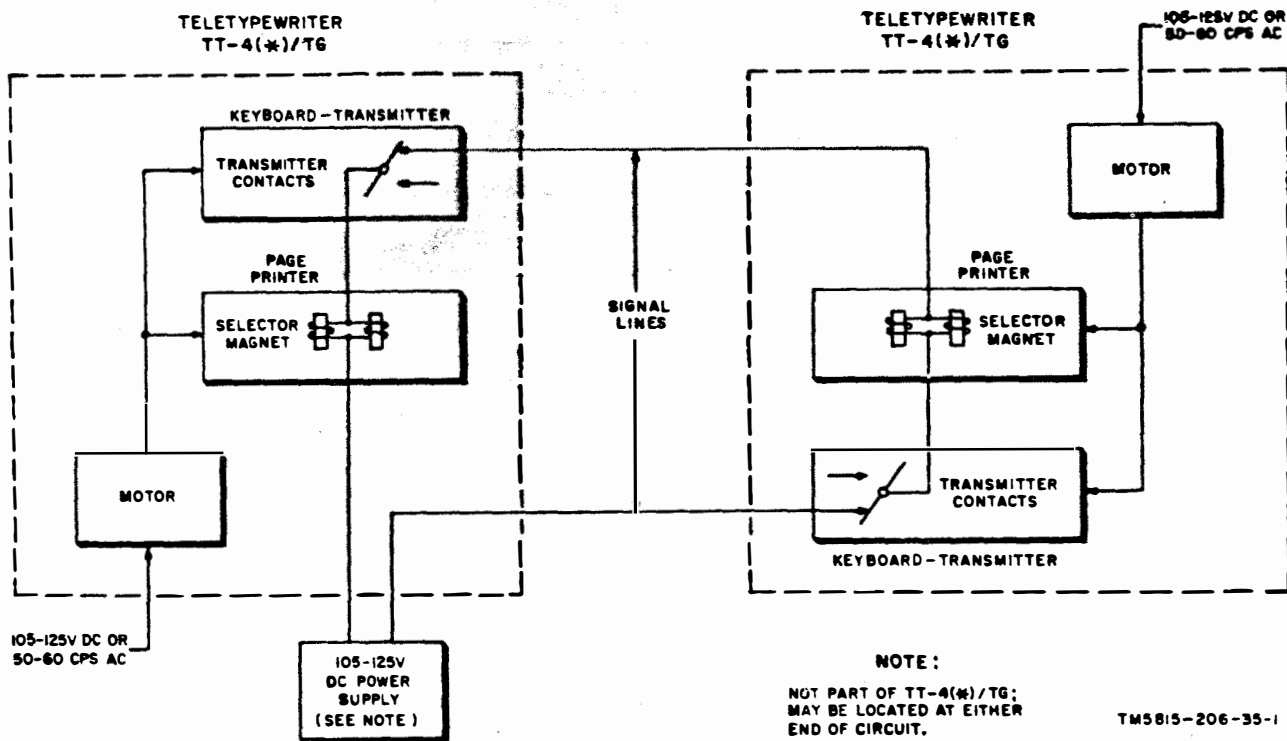
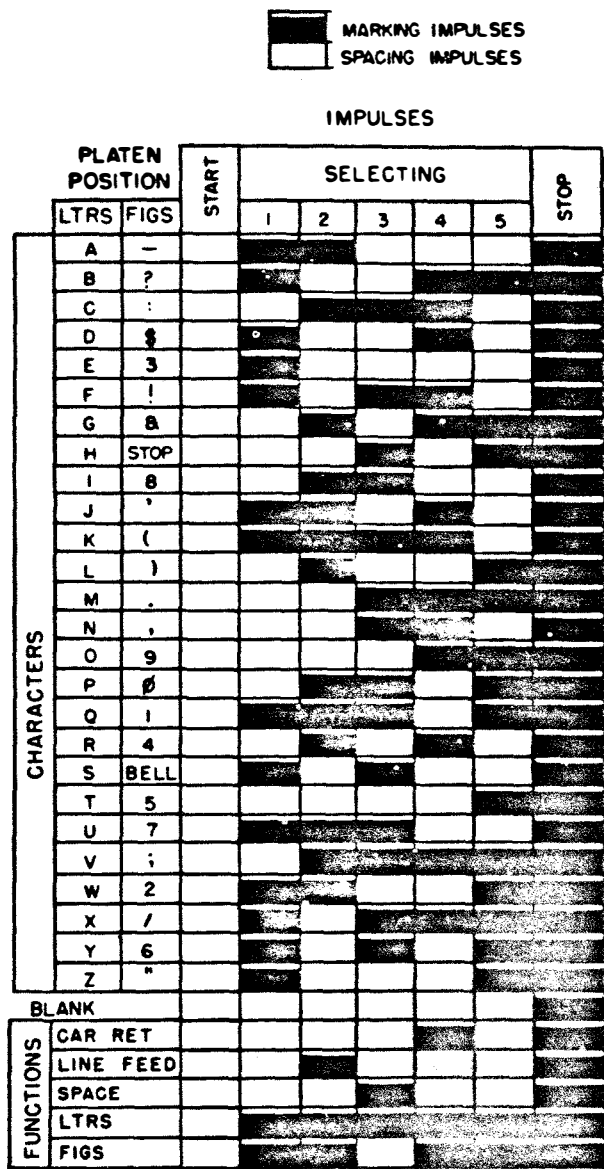

Figure 1. Basic teletypewriter circuit showing two teletypewriters TT-4(*)/TG interconnected for neutral operation.



—22—22—22—22—22—22—31—

IMPULSE LENGTHS IN MILLISECONDS
AT STANDARD SPEED OF 60 WORDS
PER MINUTE

TM5815-206-35-213

Figure 2. Teletypewriter code chart.

4. Start-Stop Five-Unit Teletypewriter Code (fig. 2)

Each teletypewriter code group consists of five code impulses preceded by a start impulse and followed by a stop impulse. The start impulse is always a *spacing* impulse, and the stop impulse is always a *marking* impulse (a and b

below). Each of the five code impulses may be either a marking or a spacing impulse, depending on the character to be printed or the function to be accomplished. Each of the 32 possible code impulse combinations is assigned to a specific character or function as shown in figure 2. The difference between marking and spacing impulses for neutral operation is as follows:

a. *Marking Impulse.* When a marking impulse is to be transmitted, a pair of transmitter contacts close to complete the signal circuit and current flows in the signal circuit for the duration of the marking impulse.

b. *Spacing Impulse.* When a spacing impulse is to be transmitted, the pair of contacts open, and no current flows in the signal circuit for the duration of the spacing impulse.

5. Block Diagram, Teletypewriter TT-4 (*) / TG (fig. 3)

a. *Sending.* When a keylever is depressed, five code bars within the keyboard-transmitter are set to positions that correspond to the five code impulses of the code group that is assigned to the character or function indicated on the keylever. Depression of the keylever also causes the transmitter mechanism to operate the transmitter contacts which send the code group to the signal line. The main shaft and intermediate shafts, driven by the motor, provide the mechanical power for operation of the transmitter mechanism.

b. *Receiving.* Teletypewriter TT-4(*)/TG receives teletypewriter code impulses from the signal line; the impulses are applied to the selector magnet in the selector mechanism. The selector mechanism responds to the code impulses to set up a mechanical parts arrangement that corresponds to the code impulses of the received code group and transfers this mechanical setting to the code-ring mechanism which mechanically selects the character to be printed or the nonprinting operation (function) to be performed. The main shaft and intermediate shafts distribute the mechanical power required to perform the printing or nonprinting operation that is selected by the code-ring mechanism.

6. Motor

The series-governed type motor used in Teletypewriter TT-4(*)/TG requires 105 to 125

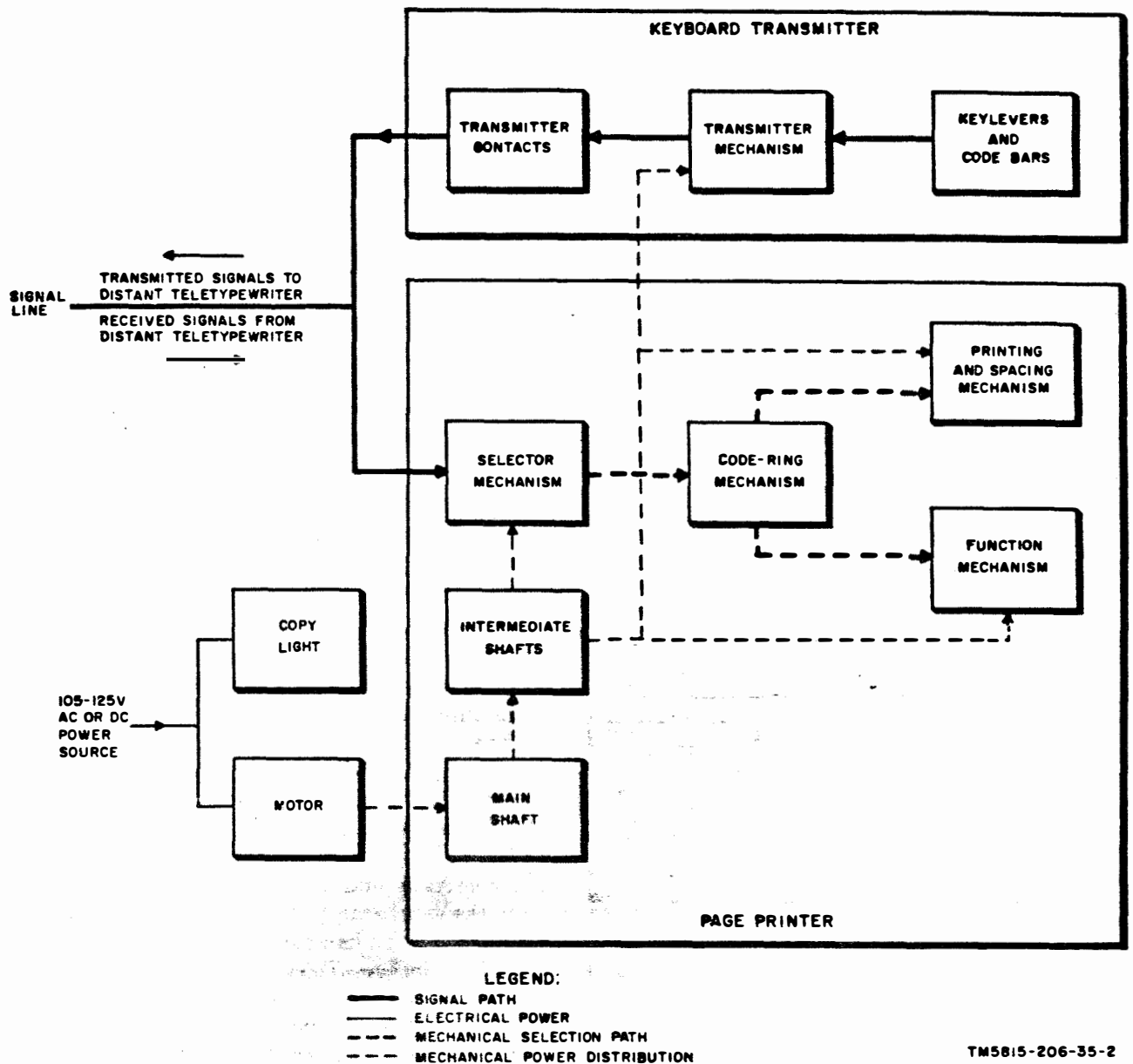

Figure 3. Teletypewriter TT-4(*)/TG, block diagram.

volts, dc or 60-cps ac. The motor includes an adjustable centrifugal-force governor that is used to maintain a motor speed of exactly 3,600 revolutions per minute (rpm). A tuning fork is required for checking the motor speed.

7. Motor Governor

The motor governor is secured to the motor armature shaft and rotates with the shaft when the motor is operating. Two contacts in the governor are connected in parallel with resistor R1 (fig. 58 and 59), and the contacts and resistor are connected in series with the

field windings and the armature. Tension of the governor spring tends to pull the movable contact against the stationary contact in the governor (fig. 4). When the motor speed becomes excessive, centrifugal force overcomes the tension of the governor spring and pulls the movable contact away from the stationary contact, adding the resistance of R1 to the motor circuit. This action causes the motor speed to decrease until the spring tension is sufficient to close the contacts, shorting out R1. The motor speeds at which the contacts open and

close depend on the tension of the governor spring. Tension is controlled by varying the position of the governor adjustment lever. The governor worm, speed adjustment gear, and governor adjustment screw (fig. 5) are used to control the position of the governor adjustment lever.

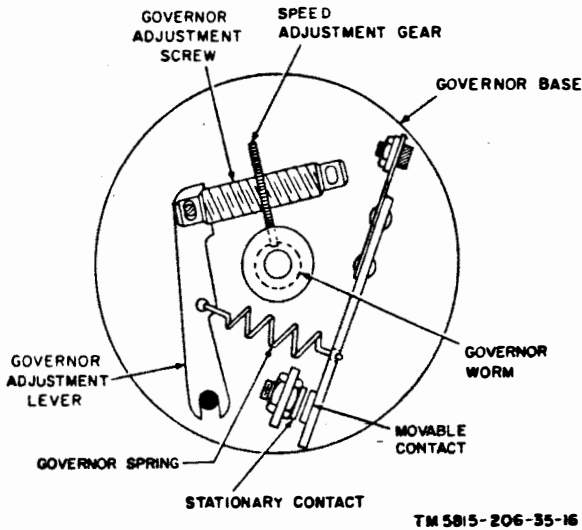

Figure 4. Motor governor, governor cover removed.

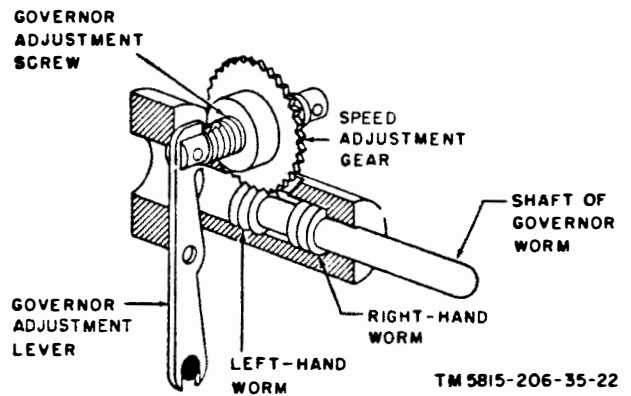

Figure 5. Governor spring tension adjustment train.

8. Mechanical Power Distribution

(fig. 6)

The main shaft, geared to the motor, rotates continuously when the motor is operating. Four pairs of gears transfer power from the main shaft to the transmitter drive shaft, the carriage-return shaft, the carriage-feed shaft, and the function shaft. A clutch fork, mounted on one end of the main shaft, transfers power to the selector friction clutch.

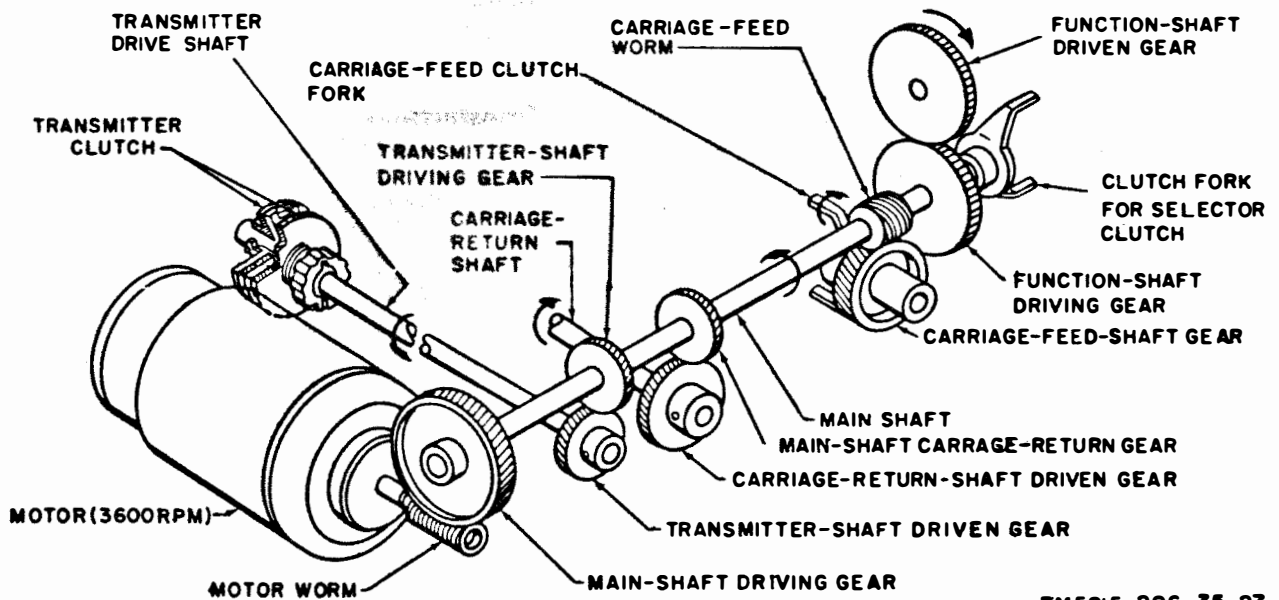

Figure 6. Mechanical power distribution.

Section II. THEORY OF KEYBOARD-TRANSMITTER

9. Keyboard-Transmitter Operation, General

Operation of the keyboard-transmitter includes: selecting the code group to be transmitted, starting the transmitter mechanism, transmitting the selected code group, and stopping the transmitter mechanism.

a. Thirty-one keylevers, five code bars, and five sensing levers (fig. 7 and 8) are used to select the code group to be transmitted (par. 10).

b. Six selector levers, a contact bail, the marking and spacing contacts, and six impulse cams on the transmitter camshaft (fig. 8 and 9) are used for transmitting the selected code group (par. 11).

Note. The transmitter contacts (fig. 1) include two contact pairs: a pair of marking contacts and a pair of spacing contacts. The marking contacts include a movable contact on the lower arm of the contact bail (fig. 9) and its associated fixed contact. The spacing contacts include a movable contact on the upper arm of the contact bail and its associated fixed contact. Only the marking contacts are used for neutral operation (par. 4a); both pairs of contacts are used for polar operation (par. 4b).

c. A universal bar, cam-stop-lever, stop cam on the transmitter camshaft (fig. 11) and a friction clutch (fig. 10) are used to start and stop the transmitter mechanism (par. 12).

10. Keyboard-Transmitter Selection of Code Group for Transmission

Selection of a code group for transmission is made when the operator presses a keylever. The nature (marking or spacing) of each of the five code impulses is established when the downward movement of the keylever positions five code bars (figs. 7 and 8). The start and stop impulses do not vary from code group to code group; the start impulse is always a spacing impulse and the stop impulse is always a marking impulse. The five code bars (one for each code impulse) are located under the keylevers. The code bars are mounted on studs that are grooved to permit only horizontal movement of the code bars. The code bar closest to the front of the keyboard is used to determine whether the first code impulse is to be a marking or spacing impulse; the second, third, fourth, and fifth code bars are used to control the second, third, fourth, and fifth code impulses respectively. The upper edge of each

code bar contains a pattern of notches. Some of the notch surfaces on each code bar are slanted downward to the left, others to the right. The notch pattern of each code bar is different from the pattern of the other code bars. Marking and spacing code impulses are selected by the keylevers and code bars as described in *a* and *b* below.

a. *Selecting Marking Code Impulse.* If the surface of the notch directly below a keylever is slanted downward to the left (C, fig. 9), downward movement of that keylever causes the code bar to move to the right, and the associated sensing lever pivots counterclockwise. The upper end of the sensing lever engages its associated code-impulse selector lever, and the code impulse controlled by that particular code bar will be a marking impulse (par. 11a).

b. *Selecting Spacing Code Impulse.* If the surface of a notch directly below a keylever is slanted downward to the right (D, fig. 9), downward movement of that keylever causes the code bar to move to the left, and the associated sensing lever pivots clockwise. The upper end of the sensing lever moves away from its code-impulse selector lever and the code impulse controlled by that particular code bar will be a spacing impulse (par. 11b).

11. Transmission of Code Group from Keyboard-Transmitter

The marking contacts (A, fig. 9) are used to transmit each code group. The contacts, connected in series in the signal circuit, close to send a marking (current) impulse and open to send a spacing (no-current) impulse. The contacts are closed by cams on the transmitter camshaft, which turns $\frac{1}{2}$ revolution each time a keylever is pressed (par. 12b and c). The contacts are opened by the contact-bail spring. The contacts transmit neutral teletype-writer impulses as described below.

a. *Transmitting Marking Code Impulse* (C, fig. 9). If the first code impulse is to be a marking impulse, the first code-impulse selector lever is latched by its sensing lever when the keylever is pressed (par. 10a). As the transmitter camshaft turns, a lobe on the first code-impulse cam pushes against a projection at the center of the first selector lever. The lower end of the

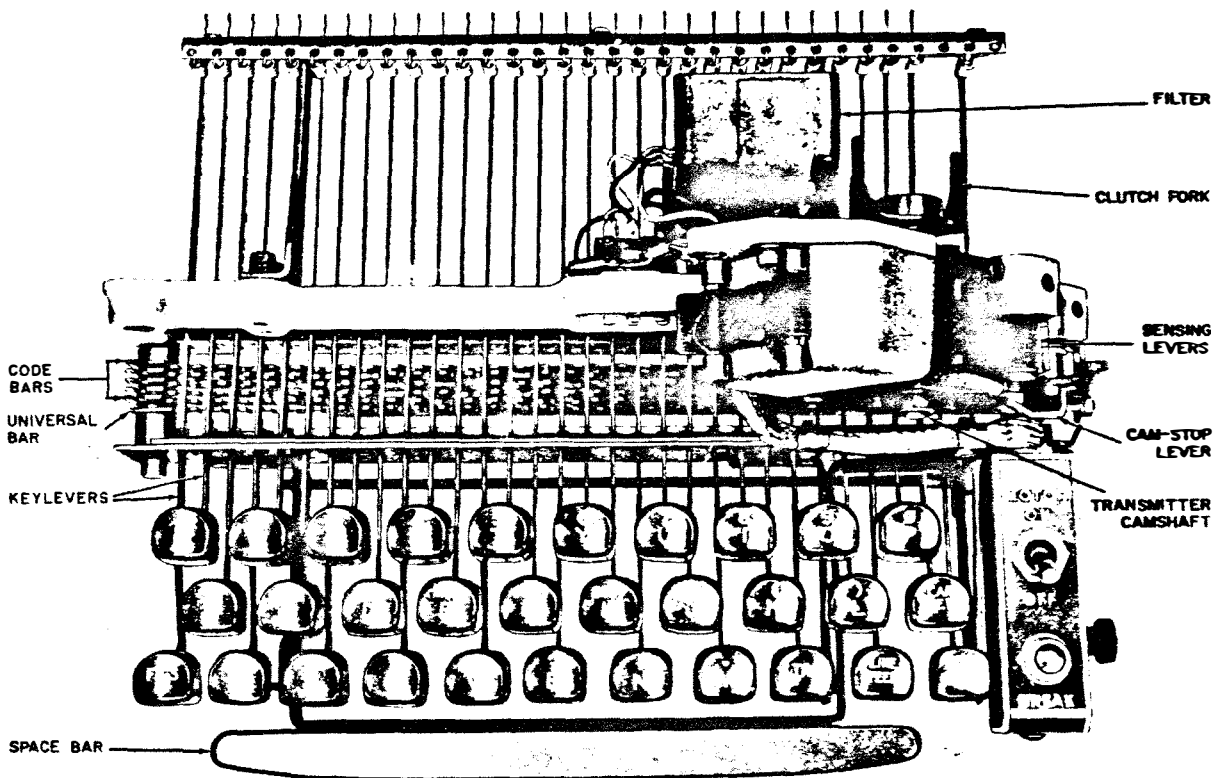

TM5815-206-35-5

Figure 7. Keyboard-transmitter, removed from teletypewriter.

selector lever pivots the contact bail clockwise slightly, closing the marking contacts to complete the signal circuit. The upper end of the selector lever does not move because it is latched by its associated sensing lever. After the code-impulse cam passes the selector lever, the projection of the selector lever moves toward the center of the cam. The selector-lever spring pulls the lower end of the selector lever downward and control of the contact bail passes to the next selector lever. If the next code impulse is to be a marking impulse also, the next selector lever will hold the contact bail in the clockwise position and the contacts will remain closed when the second code-impulse cam operates its selector lever. If the next code impulse is to be a spacing impulse, it will be transmitted as described in *b* below.

b. Transmitting Spacing Code Impulse (D, fig. 9). If a code impulse is to be a spacing impulse, the selector lever for that impulse is not latched by its sensing lever when the key-lever is pressed (par. 10*b*). As the transmitter

camshaft turns, a lobe on the code-impulse cam pushes against the projection in the center of its associated selector lever and the selector lever pivots counterclockwise slightly around its bearing. The selector lever pivots counterclockwise because the upper end of the selector lever is not latched by its sensing lever and the lower end of the selector lever is held in position by the selector-lever spring.

c. Transmitting Start and Stop Impulses. The first impulse of each code group is the start impulse. The five code impulses are transmitted in sequence immediately after the start impulse. The last impulse of each code group is the stop impulse. The start-stop selector lever and the start-stop impulse cam on the transmitter camshaft are used to operate the marking contacts to transmit the start and stop impulses (A and B, fig. 9). The start-stop impulse cam and the start-stop selector lever are in alignment directly behind the fifth code-impulse cam and the fifth code-impulse selector lever respectively.

(1) Signal circuit condition before trans-

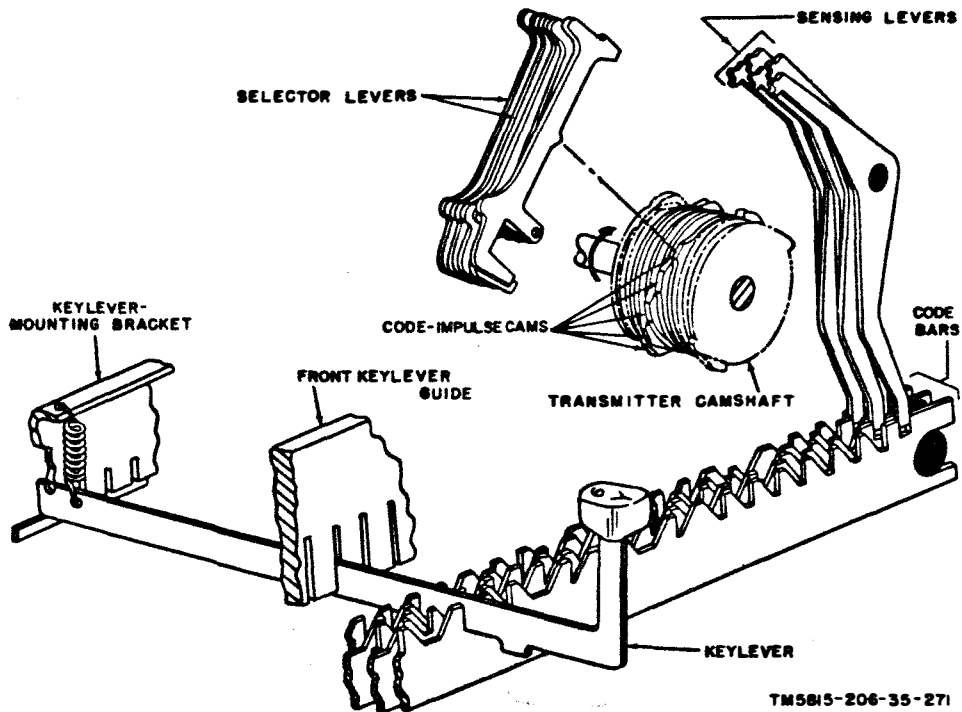

Figure 8. Keyboard-transmitter mechanism showing code-impulse selection mechanism.

mission. Before a keylever is pressed to begin transmission of a code group, the transmitter camshaft is held stationary mechanically (par. 12); the transmitter contacts are held in the closed position by the start-stop impulse cam and the start-stop selector lever (B, fig. 9). The top of the start-stop selector lever is latched permanently.

- (2) *Transmitting start impulse.* When a keylever is pressed, the transmitter camshaft starts turning (par. 12). A lobe of the start-stop impulse cam (A, fig. 9) moves away from the start-stop selector lever and the selector-lever spring pulls the selector lever downward. The contact-bail spring pivots the contact bail counterclockwise slightly and the marking contacts open to send the start impulse.
- (3) *Transmitting stop impulse.* The stop impulse begins when a lobe of the fifth code-impulse cam on the transmitter camshaft moves away from the fifth code-impulse selector lever and a lobe of the start-stop impulse cam

moves against the start-stop selector lever (B, fig. 9). Because the top of the selector lever is latched permanently, the bottom of the lever pushes against the contact bail to close the contacts to send the stop impulse. The contacts remain closed until the start impulse of the next code group is transmitted ((2) above). If another keylever is not pressed immediately, rotation of the transmitter camshaft is stopped mechanically (par. 12).

12. Starting and Stopping Transmission from Keyboard-Transmitter

Transmission begins when the transmitter camshaft starts to turn and ends when rotation of the transmitter camshaft is halted. A friction clutch (fig. 10) is used to transfer mechanical power from the constantly rotating transmitter drive shaft to the transmitter camshaft (a below). The stop cam, cam-stop lever, cam-stop-lever latch, and universal bar are used to start and stop rotation of the camshaft (b and c below).

a. *Transmitter Friction Clutch.* The friction clutch consists of the clutch fork which

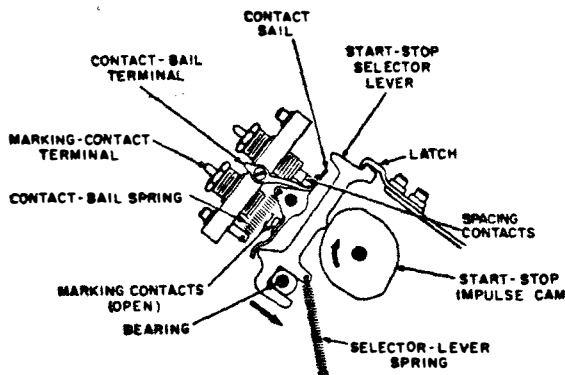

A. TRANSMITTING START IMPULSE

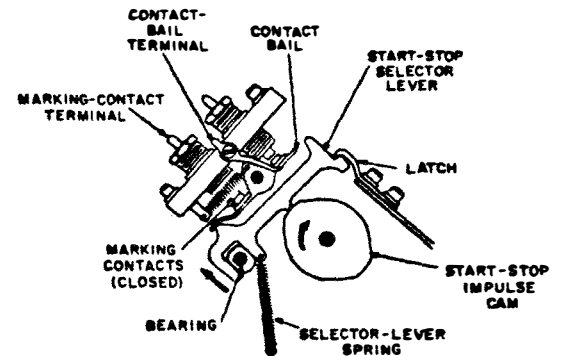

B. TRANSMITTING STOP IMPULSE

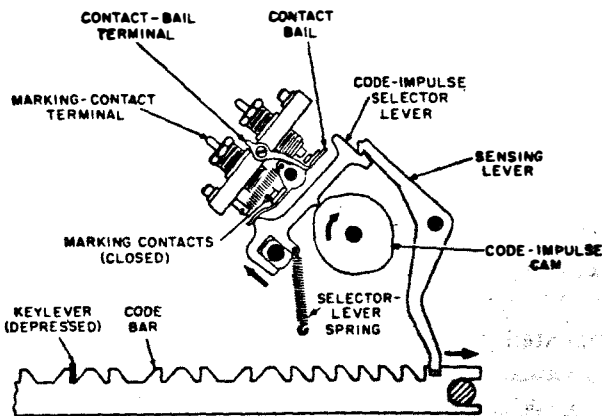

C. TRANSMITTING MARKING CODE IMPULSE

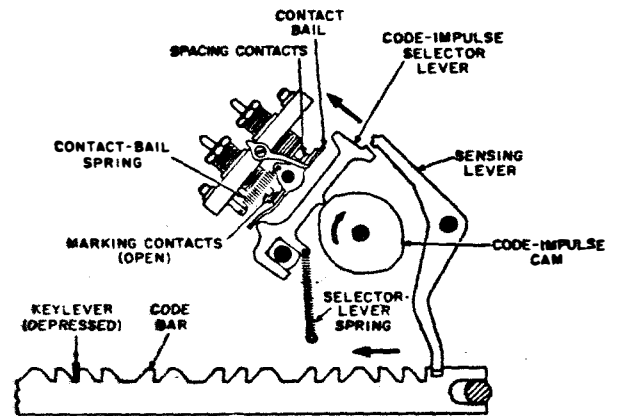

D. TRANSMITTING SPACING CODE IMPULSE

TM5815-206-35-172

Figure 9. Transmission of start, stop spacing, and marking impulses.

is firmly attached to the transmitter camshaft and the friction assembly which is attached to the transmitter drive shaft. Two prongs of the clutch fork engage two notches in the center clutch disk (fig. 10). Pressure of the friction-clutch spring causes the three clutch disks and two felt friction plates to be compressed, and the friction between the outer disks and the felt friction plates is sufficient to turn the clutch fork when the motor is running and the transmitter camshaft is free to rotate. When the vertical arm of the cam-stop lever (fig. 11) moves into the path of one of the two stop lobes of the stop cam on the transmitter camshaft, while the camshaft is turning, the stop lobe strikes against the arm of the cam-stop lever. The camshaft stops turning and the center clutch disk and the felt friction plates are held stationary between the two rotating outer clutch disks. When the arm of the cam-stop

lever is moved out of the path of the stop lobe, the transmitter camshaft starts to turn, driven by the friction between the outer clutch disks and the felt friction plates. The TT-4B/TG includes a three-piece friction-adjusting assembly (driving collar and two-piece friction-adjusting collar) for adjusting the pressure of the friction-clutch spring (A, fig. 10). The TT-4A/TG includes a one-piece friction-adjusting collar for spring pressure (B, fig. 10).

b. *Starting Transmission of Code Group.* When a keylever is pressed, it strikes one of the slanted surfaces of the universal bar (fig. 11) and the universal bar is cammed to the right. As it moves to the right, it strikes the universal-bar adjusting screw on the cam-stop-lever latch, pivoting the latch counterclockwise. The repeat-blocking-lever spring pulls the repeat-blocking lever counterclockwise until it strikes the right hand arm of the cam-

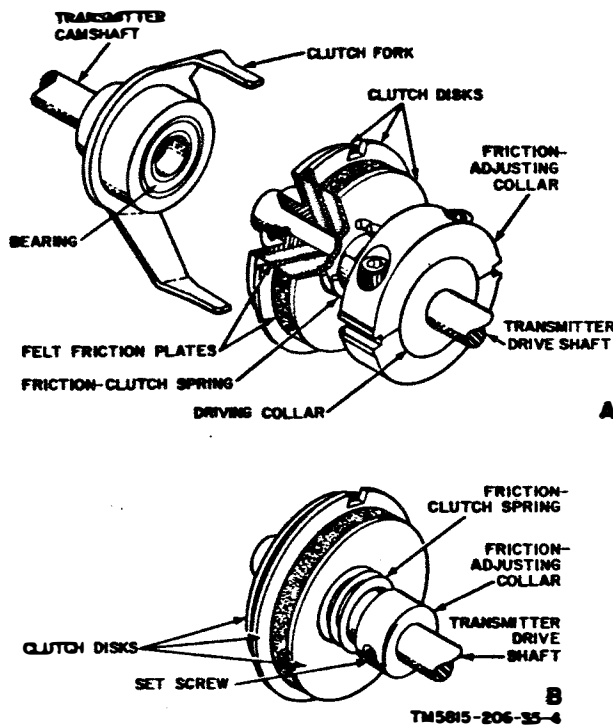

Figure 10. Transmitter friction clutch.

stop lever. The cam-stop-lever latch continues to pivot, forming a slot between it and the repeat-blocking lever. The tension of the cam-stop-lever spring causes the cam-stop lever to pivot clockwise. The end of the right hand arm of the cam-stop lever moves downward, into the slot, and the vertical arm moves away from the stop lobe of the stop cam, permitting the friction clutch to start rotation of the transmitter camshaft (a above).

c. *Stopping Transmission.* When the transmitter camshaft nears the end of the $\frac{1}{2}$ revolution, one of two projections on the side of the stop cam strikes the left-hand arm of the cam-stop lever, causing the cam-stop lever to pivot counterclockwise. The vertical arm of the cam-stop lever moves to the left, and the transmitter camshaft stops turning when the stop lobe on the stop cam strikes the top of the vertical arm. The cam-stop lever is locked in the counterclockwise position as described in (1) or (2) below.

- (1) If the operator has released the depressed keylever, the universal-bar spring pulls the universal bar to the left. The cam-stop-lever-latch spring pivots the cam-stop-lever latch clock-

wise. The top of the latch moves under the right-hand arm of the cam-stop lever, locking the cam-stop lever in the counterclockwise position.

- (2) If the operator has not released the keylever from its downward position, the repeat-blocking-lever spring pulls the repeat-blocking lever counterclockwise. The top of the repeat-blocking lever moves under the right-hand arm of the cam-stop lever, locking the cam-stop lever in the counterclockwise position.

13. Space Repeat Operation

When the space bar (fig. 7) is pressed and immediately released, one space code group is transmitted. When the space bar is held down, repeated space code groups are transmitted until the space bar is released. Reception of the space code group causes the carriage of the page printer to move one space to the right without printing a character. The space code group is the only code group that can be transmitted repeatedly from the TT-4(*)/TG with one downward movement of a keyboard control.

a. When the space bar is pressed, the space-bar lever (figs. 11 and 12) positions the five code bars for the space code group (fig. 2) it moves the universal bar to the right to pivot the cam-stop-lever latch and the repeat lever counterclockwise, causing the repeat-blocking lever to turn clockwise. Under these conditions, a slot appears below the right-hand arm of the cam-stop lever. The cam-stop-lever spring pivots the cam-stop lever clockwise, permitting the friction clutch to turn the transmitter camshaft to transmit repeated space code groups. The repeat lever prevents the repeat-blocking lever from moving under the right hand arm of the cam-stop lever as occurs during transmission of all other code groups (par. 12c(2)).

b. When the space bar is released, transmission is halted as described in paragraph 12c(1).

14. Sensing-Lever Locking-Bail Operation

The five sensing levers are positioned each time a keylever or the space bar is pressed (par. 10). During transmission of each code

moves un-
 the cam-
 stop lever
 on.
 eased the
 position,
 ring pulls
 interclock-
 blocking
 hand arm
 the cam-
 clockwise

pressed and
 group is
 held down,
 nitted un-
 on of the
 f the page
 t without
 de group
 anmitted
 with one
 ntr

the space-
 e five code
 it moves
 t the cam-
 counter-
 g lever to
 ns, a slot
 the cam-
 ng pivots
 tting the
 camshaft
 ups. The
 ring lever
 m of the
 nmission

transmis-
 h 12c(1).

ration
 ned each
 s pressed
 ach code

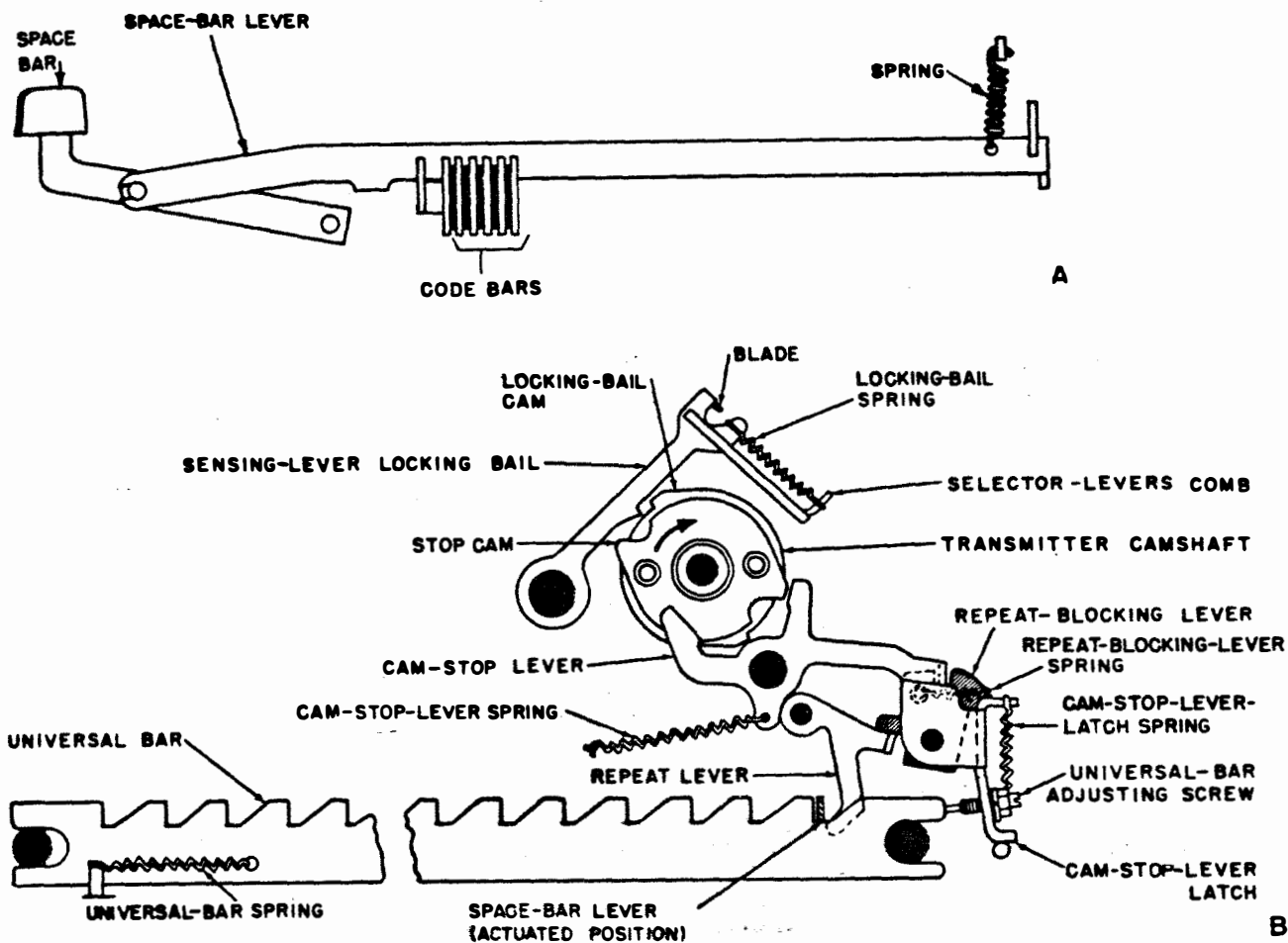

Figure 11. Transmitter camshaft control mechanism.

group, the sensing levers are locked in their selected positions by the blade of the sensing-lever locking bail (fig. 11). Movement of the sensing-lever locking bail is controlled by the

locking-bail spring and the locking-bail cam on the transmitter camshaft. The tension of the spring causes the bail to ride against the outer surface of the cam at all times. Between transmission of code groups, the cam is stationary and the bail is held upward by one of the two lobes of the cam.

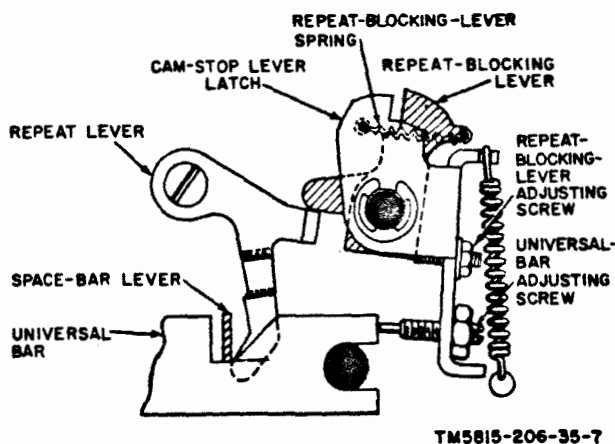

Figure 12. Repeat-lever operation.

a. When a code group is to be transmitted, the transmitter camshaft starts turning and the sensing-lever locking bail pivots clockwise slightly to move against a low portion of the cam (fig. 11). In this position, the blade of the bail engages a projection on the top of each of the sensing levers, locking the sensing levers in position. Downward movement of another keylever is not possible while the sensing levers are locked by the bail.

b. During transmission of the stop impulse, a lobe of the locking-bail cam causes the bail

to pivot counterclockwise slightly. The blade of the bail moves away from the sensing-lever projections and the sensing levers are free to be repositioned by the downward movement of another keylever.

15. Sequence of Keyboard-Transmitter Operations

The following chart lists the sequence of operations that occur when a keylever of the keyboard-transmitter is pressed.

Sequence	Impulse control and transmission operations	Starting and stopping operations
1	Keylever pressed downward (fig. 8).	
2	Keylever strikes slanted notches of five code bars, camming them individually to left or right according to code to be transmitted (fig. 8).	Keylever strikes slanted notch of universal bar, camming universal bar to right (fig. 11).
3	Code bars pivot five sensing levers clockwise or counterclockwise individually (fig. 8).	Universal bar strikes its adjusting screw, pivoting cam-stop lever latch counterclockwise (fig. 11).
4		Cam-stop lever pivots clockwise; right-hand arm of lever drops into notch between cam-stop-lever latch and repeat-blocking lever, vertical arm of cam-stop lever moves away from stop cam (fig. 11).
5		Transmitter camshaft starts turning, driven by friction clutch (fig. 10).
6	Sensing-lever locking bail moves to low portion of locking-bail cam, locking sensing levers in selected position (fig. 11).	
7	Start-stop selector lever moves to low portion of start-stop impulse cam on transmitter camshaft (A, fig. 9).	
8	Contact-bail spring pivots contact bail counterclockwise, opening contacts to send start impulse.	
9	Lobe of No. 1 code-impulse cam pushes No. 1 selector lever. If latched by sensing lever, lower end of selector lever turns contact bail clockwise to send marking impulse (C, fig. 9). If not latched by its sensing lever, upper end of selector lever pivots contact bail counterclockwise to send spacing impulses (D, fig. 9).	
10	Lobes of No. 2, 3, 4, and 5 code-impulse cams operate in sequence to transmit second, third, fourth, and fifth code impulses (C and D, fig. 9).	
11		Projection on side of stop cam strikes left-hand arm of cam-stop lever, pivoting cam-stop lever counterclockwise (fig. 11).
12		Cam-stop lever latched in counterclockwise position by cam-stop-lever latch for repeat-blocking lever.
13	Lobe of start-stop impulse cam pivots contact bail clockwise, closing contacts to send stop impulse (B, fig. 9).	
14	Lobe of locking-bail cam pivots locking bail counterclockwise; blade of bail moves away from sensing levers (fig. 11).	
15		Stop lobe of stop cam strikes vertical arm of cam-stop lever. Transmitter camshaft stops turning.

Section III. THEORY OF PAGE PRINTER

16. Page Printer Operation, General

Operation of the page printer is controlled by the teletypewriter code groups that are received from either the keyboard-transmitter of the same teletypewriter or the transmitter of

another teletypewriter that is connected to the same signal circuit as the receiving teletypewriter. The start impulse (first impulse of each code group) causes the page printer to start a cycle of mechanical operation. The five code im-

pulses, received in sequence in the selector magnet of the page printer, are used by the selector mechanism to select the character to be printed or the nonprinting mechanical operation to be performed (line-feed, figures-shift, etc.). After the fifth code impulse is received, the selected character is printed, or the selected mechanical operation is performed automatically by the page printer. The stop impulse (last impulse of each code group) is used to stop the page printer until the start impulse of the next code group is received.

17. Selector-Magnet Operation

The two coils of the selector magnet are connected to the signal circuit. The selector magnet responds to incoming marking and spacing impulses as described below.

a. Condition During Marking Impulse. When either a marking code impulse or the stop impulse is received current flows through the two selector-magnet coils and a magnetic field is present around the coils (fig. 13). The magnetic field is strong enough to overcome the tension of the armature spring and the armature is held against the armature upper-stop screw (marking position of armature).

b. Condition During Spacing Impulse. When either a spacing code impulse or the start impulse is received, current stops flowing in the selector-magnet coils; no magnetic field is present around the coils; and the armature spring pulls the armature against its lower-stop screw (spacing position of armature).

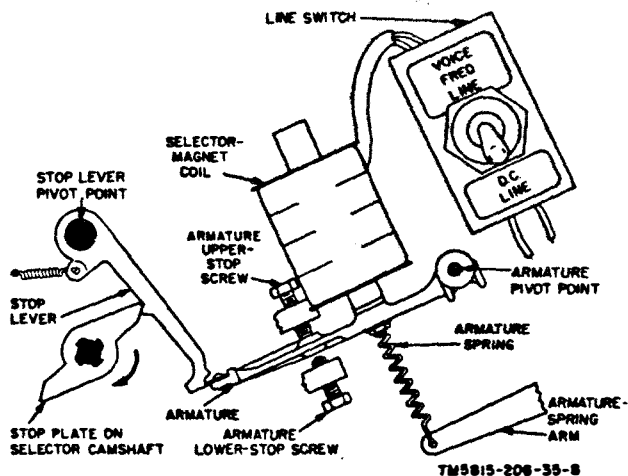

Figure 13. Armature held in marking position by energized selector magnet.

18. Starting and Stopping Selector Camshaft Rotation

a. Selector Friction Clutch. When the motor is operating, the main shaft and the selector clutch fork that is fastened to one end of the main shaft rotate continuously (fig. 6). Two fingers of the clutch fork are engaged with two notches in the center clutch disk of the friction clutch (fig. 14). The center clutch disk and the two felt friction plates rotate continuously with the clutch fork. The compressed clutch spring presses one outer clutch disk, the felt friction plates, and the center clutch disk against the other outer clutch disk, causing a constant torque to be applied to the selector camshaft. Rotation of the selector camshaft is controlled as described in *b* through *d* below.

b. Condition Before Receipt of Start Impulse. Before the start impulse is received, the armature is in the marking position, against the armature upper-stop screw (par. 17a). Torque of the selector friction clutch causes one lobe of the stop plate on the selector camshaft to press against the projection in the center of the stop lever, but the lower end of the armature blocks counterclockwise movement of the stop lever and the stop plate and selector camshaft are not permitted to rotate (A, fig. 15).

c. Starting Selector Camshaft Rotation. When the start impulse is received, the armature spring pulls the armature downward, against the armature lower-stop screw (par. 17b), and the lower end of the armature releases the stop lever (fig. 13). Pressure of the stop plate causes the stop lever to pivot counterclockwise slightly, and the selector camshaft is permitted to start turning (B, fig. 15).

d. Stopping Camshaft Rotation. Immediately after the selector camshaft starts turning, the five code impulses are received in sequence (par. 19). When the camshaft nears the end of $\frac{1}{2}$ revolution, the stop impulse is received in the selector-magnet coils. The magnetic field set up by the stop impulse pulls the armature against its upper-stop screw and the lower end of the armature moves upward into the patch of the stop lever. Rotation of the selector camshaft is halted when the lobe of the stop plate strikes the projection of the stop lever (A, fig. 15). The stop impulse prevents the

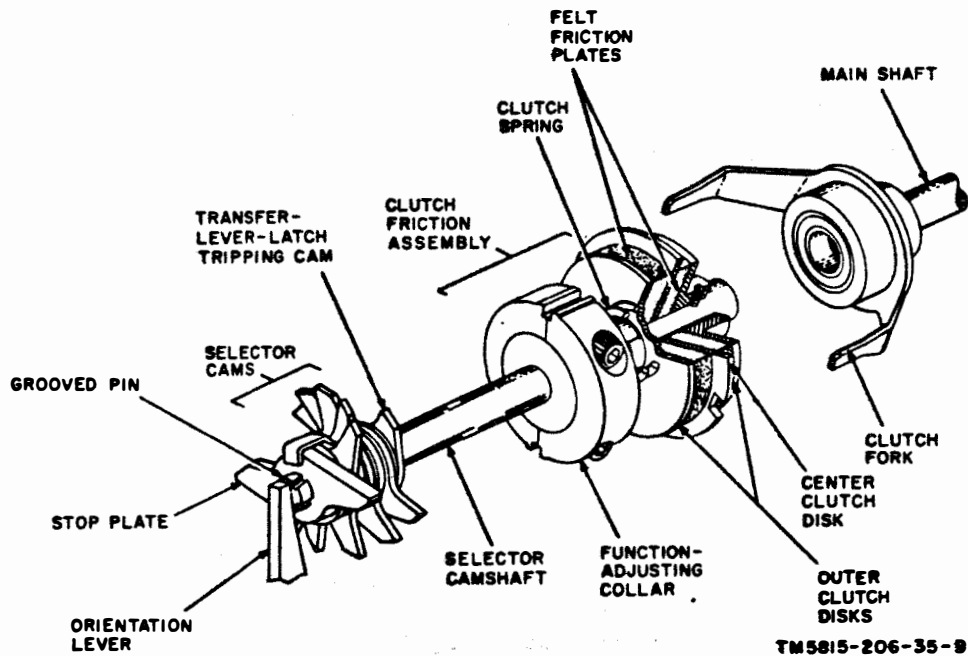

Figure 14. Selector camshaft and selector friction clutch.

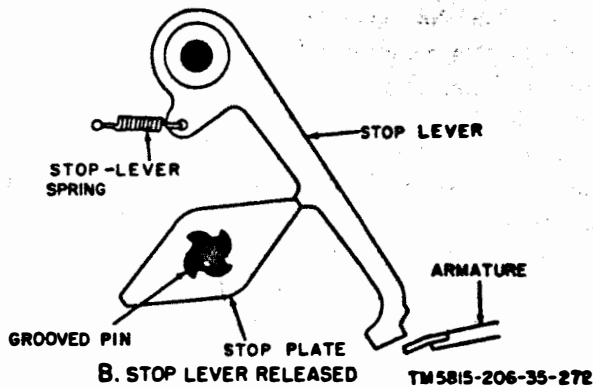
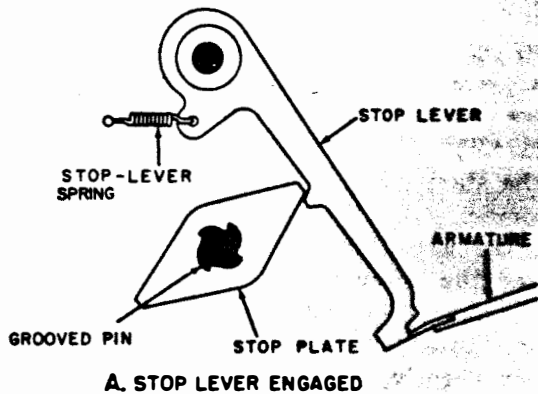

Figure 15. Stop lever in engaged and released positions.

selector camshaft from turning more than $\frac{1}{2}$ revolution for each code group. The camshaft remains stationary until the start impulse of the next code group is received (c above).

19. Recording Code Impulses

The five code impulses of a code group are received in sequence immediately after the selector camshaft starts turning (par. 18c). Each of the code impulses is either a marking (current) or spacing (no-current) impulse (fig. 2), as determined by the code group assigned to the character to be printed or the nonprinting operation to be performed by the page printer. A marking code impulse always causes the armature to be drawn upward, against its upper-stop screw (fig. 13). A spacing code impulse always allows the armature spring to pull the armature downward against its lower-stop screw. Five selector cams (figs. 14 and 16), five selector levers, and five Y-levers (one of each for each code impulse) are used to record the position of the armature during each of the five code impulses are being received. The selector cams are staggered around one-half the circumference of the selector camshaft (fig. 14) which makes $\frac{1}{2}$ revolution for each code group received. The first selector cam and its associated selector lever and Y-lever record the

nature (marking or spacing) of the first code impulse; the second selector cam, and its associated selector and Y-levers record the second impulse; and so on, for each of the remaining code impulses.

a. Recording Marking Code Impulse. When a marking code impulse is received, the armature is held in the marking (upper) position and the broad lower end of the armature latches the lower end of the five selector levers (A, fig. 16). A lobe of the selector cam that corresponds to the code impulse being received (first selector cam for first code impulse, etc.) rotates to the position shown and pushes against the center of its associated selector lever. Movement of the lower end of the selector lever is prevented by the armature. The upper end of the selector lever moves clockwise, sliding on its bearing. The upper end of the selector lever pushes its associated Y-lever clockwise (unless it was set to the clockwise

position by the previous code group). When the cam lobe moves beyond the center of the selector lever, the selector-lever spring pulls the selector lever away from the Y-lever, but the Y-lever is held in the clockwise position by either the Y-lever detent or the TT-4B/TG or the friction plate or the TT-4A/TG (fig. 19). In this way, each time a marking code impulse is received, its associated Y-lever is moved to the clockwise position.

b. Recording Spacing Code Impulse. When a spacing code impulse is received, the armature is positioned downward, away from the selector levers (B, fig. 16). A lobe of the selector cam associated with the code impulse rotates to the position shown and pushes against the center of its associated selector lever. The armature is not in position to block movement of the lower end of the selector lever and the lower end of the selector lever moves upward, turning its associated Y-lever counterclockwise. The Y-lever detent of the TT-4B/TG or the friction plate or the TT-4A/TG holds the Y-lever in the counterclockwise position. In this way, each time a spacing code impulse is received, its associated Y-lever is moved to the counterclockwise position.

c. Rangefinder Mechanism. The time required by each selector cam to position its Y-lever is approximately 20 percent of the total time that the code impulse is present in the selector magnet. Under ideal conditions, maximum reliability of operation is obtained when the Y-lever is positioned during the middle portion of the code impulse. The rangefinder mechanism permits selection of the portion of each code impulse that will be used for the positioning of the Y-lever. The rangefinder mechanism is used to control the angle between the stop plate and the first selector cam on the selector camshaft (fig. 17). Decreasing the angle causes the selector cams to position their respective Y-levers during the early part of the code impulses. Increasing the angle causes the cams to position their respective Y-levers during the later part of the code impulses. The angular position of the stop plate is controlled by the position of the grooved pin. When the grooved pin is moved inward, the angle is increased; when the pin is moved outward, the angle is decreased. The position of the grooved pin is controlled by a train of parts which in-

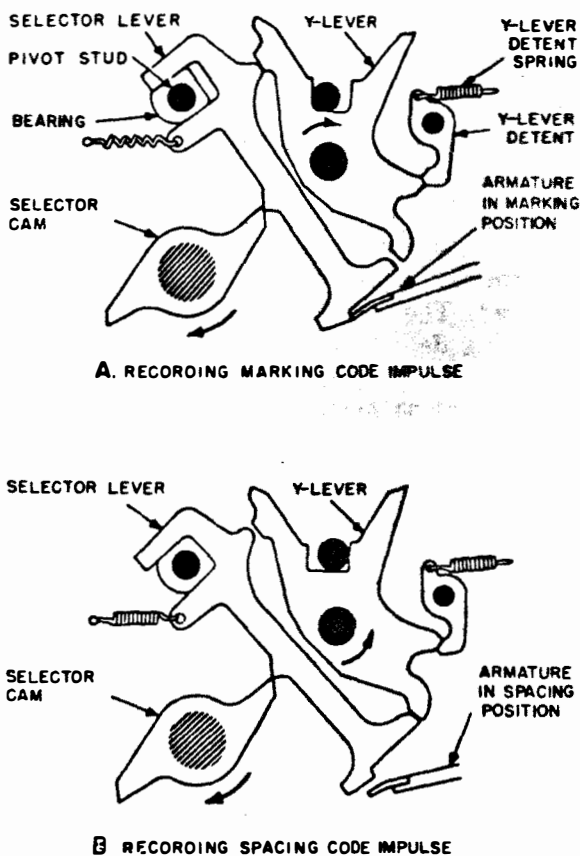

TM 5815-206-35-273

Figure 16. Recording marking and spacing code impulses.

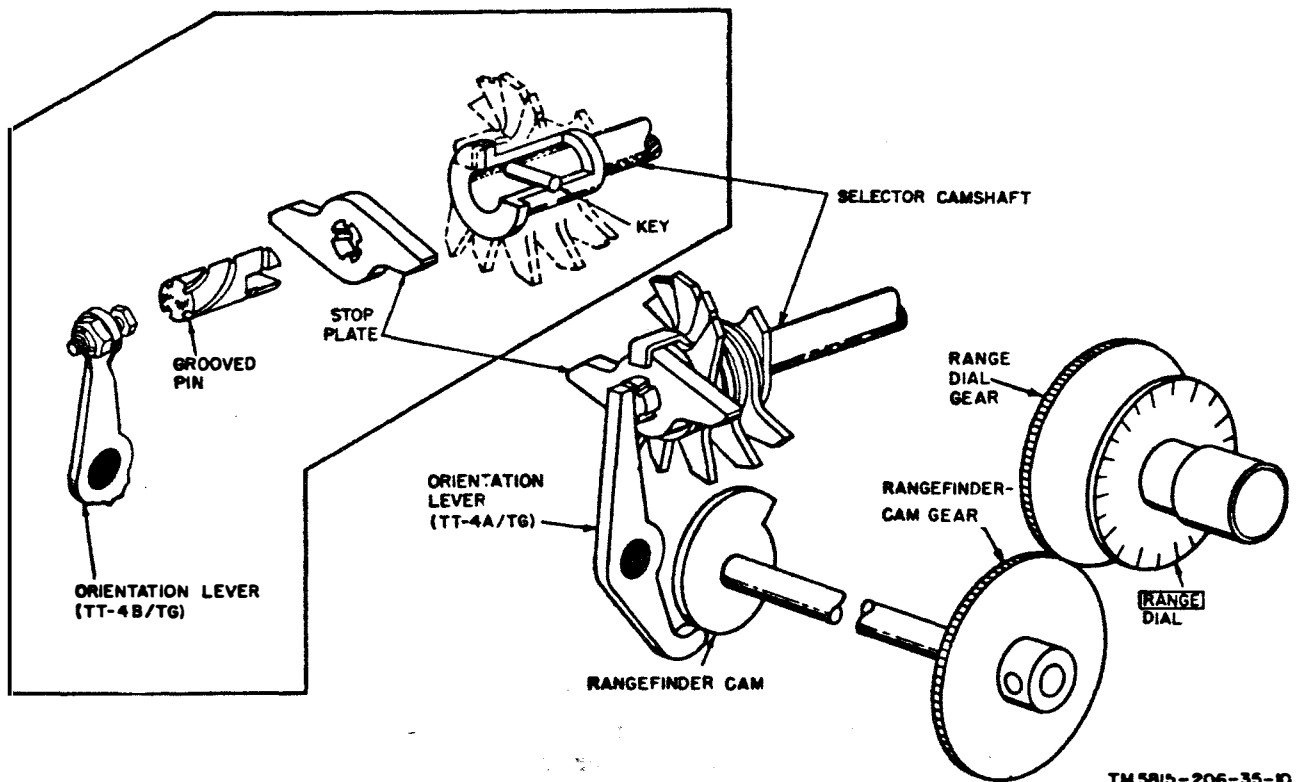

TM 5815-206-35-D

Figure 17. Rangefinder mechanism.

cludes the orientation lever, rangefinder cam, rangefinder-cam gear, rangefinder dial gear, and RANGE dial. Clockwise rotation of the RANGE dial causes the grooved pin to move inward; counterclockwise rotation causes the pin to move outward.

d. Controlling Armature Spring Tension.

Tension of the armature spring is a critical factor in the operation of the page printer. The tension should be checked, and if necessary, adjusted for optimum performance of the page printer whenever the signal line current is changed. The spring tension is adjustable to a very fine degree with the armature spring

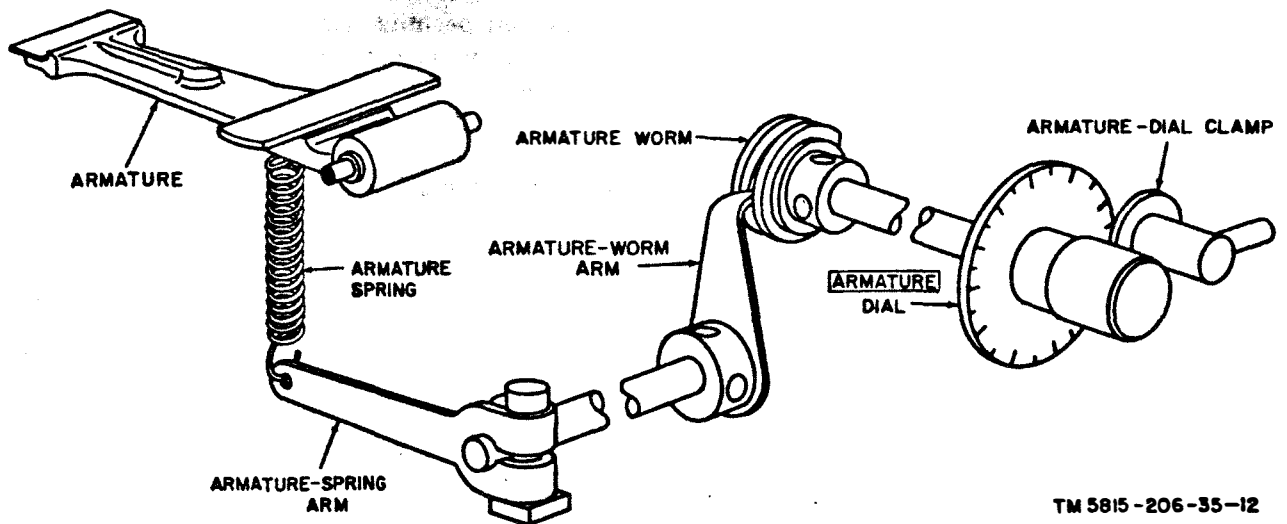

TM 5815-206-35-12

Figure 18. Armature spring tension adjustment mechanism.

tension adjustment mechanism (fig. 18). Rotation of the ARMATURE dial clockwise causes the armature-spring arm to move downward, increasing the tension applied to the armature by its spring. Turning the dial counterclockwise decreases the spring tension.

e. Sequence of Selector Mechanism Operations. The following chart lists the sequence of operations that occur in the selector mechanism of the page printer when a code group is received.

Selector mechanism operation sequence chart

- 1 Start impulse received in selector-magnet coils (fig. 13).
- 2 Selector-magnet armature drops to spacing position.
- 3 Stop lever released by armature (B, fig. 15).
- 4 Stop plate released by stop lever.
- 5 Selector camshaft starts revolving (fig. 14).
- 6 First code impulse pulls armature up or armature remains down, depending on whether impulse is marking or spacing (fig. 16).
- 7 No. 1 code-impulse cam pushes middle of No. 1 selector lever.
- 8 No. 1 selector lever pivots about end of armature if armature is up (marking), or about selector-lever pivot stud if armature is down (spacing impulse).
- 9 No. 1 selector lever pushes No. 1 Y-lever clockwise if selector lever is pivoting about armature end (marking impulse) or counterclockwise if selector lever is pivoting about pivot stud (spacing impulse).
- 10 Second, third, fourth, and fifth code impulses in turn operate the corresponding parts of the selector mechanism, as described above for the first impulse, so that each Y-lever is set clockwise or counterclockwise as determined by its corresponding code impulse.
- 11 Latch-tripping cam turns transfer latch (par. 20e).
- 12 Stop impulse received in selector-magnet coils.
- 13 Armature pulled upward to marking position.
- 14 Stop lever latched by armature (A, fig. 15).
- 15 Stop plate moves against stop lever.
- 16 Stop plate held by stop lever.
- 17 Selector camshaft stopped at end of $\frac{1}{2}$ revolution.

20. Transfer Operation

The purpose of the transfer operation is to pivot each of the five code rings to a position (marking or spacing) to correspond with the nature (marking or spacing) of each of the five code impulses of a received code group. When positioned, the code rings select a stop bar (par. 21) which controls the selection of the character to be printed or the function (non-printing mechanical operation) to be performed. The transfer operation occurs automatically, immediately after the five Y-levers

are positioned clockwise or counterclockwise in accordance with the nature of each of the five code impulses of the code group (par. 19a and b). Five T-levers (fig. 19) are used to position the code rings. The T-levers are mounted on a common pivot stud that is attached to one arm of the transfer lever. Each T-lever is mounted above, and in alignment with, an associated Y-lever. The vertical arm of each T-lever is in engagement with a slot in the tail of an associated code ring. The five code rings (fig. 20) pivot around the stop-arm shaft. The code rings are moved to the marking and spacing positions as described in a and b below. During printing, the code rings of the TT-4B/TG are locked in their selected positions as described in d below. The TT-4A/TG does not include the code-ring locking feature.

a. Condition Before Transfer Operation. When the five Y-levers are being positioned (par. 19), the transfer-lever latch holds the transfer lever in the counterclockwise position against the pull of the transfer-lever spring, and the five T-levers are held above their respective Y-levers (fig. 19).

b. Positioning T-levers and Code Rings. Immediately after the fifth selector cam positions the fifth Y-lever, a lobe of the transfer-lever-latch tripping cam (fig. 14) pushes against one arm of the transfer-lever latch (fig. 19). The latch pivots counterclockwise, releasing the lower arm of the transfer lever. The tension of the transfer-lever spring turns the transfer-lever clockwise and the T-levers move downward, against the upper arms of the Y-levers (fig. 20).

- (1) *Setting code ring to marking position.* If a Y-lever is in the marking (clockwise) position when its associated T-lever moves downward, the right hand arm of the T-lever strikes the right hand arm of the Y-lever. The left hand arm of the T-lever clears the left hand arm of the Y-lever and the T-lever pivots counterclockwise, causing its associated code ring to pivot clockwise to the marking position (A, fig. 20).
- (2) *Setting code ring to spacing position.* If a Y-lever is in the spacing (counterclockwise) position when the T-levers move downward, the left hand

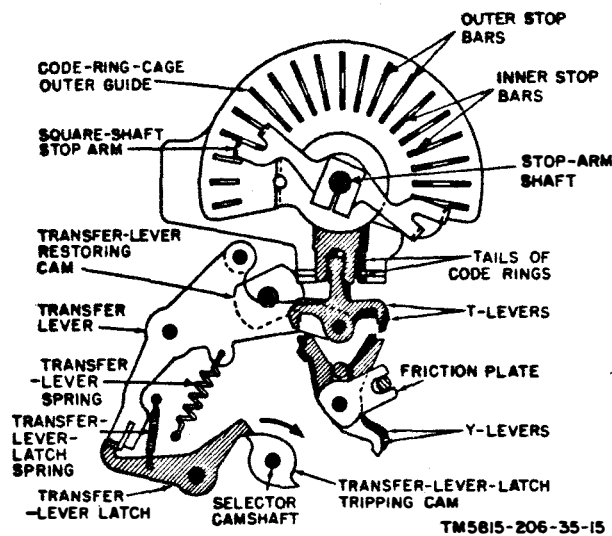

Figure 19. Transfer lever in latched position.

arm of its associated T-lever strikes the left hand arm of the Y-lever and the T-lever pivots clockwise, causing its associated code ring to pivot counterclockwise to the spacing position (B, fig. 20).

c. *Restoring Transfer Lever to Latched Position.* When the transfer operation occurs (b above), the transfer lever must be restored to its original position (latched by the transfer-lever latch) to permit the positioning of the Y-levers in accordance with the code impulses of the next code group.

- (1) During the transfer operation, the transfer-lever roller moves toward a low part of the transfer-lever restoring cam (fig. 20). Immediately after the transfer operation occurs, the restoring cam starts to turn, ((2) below). A lobe of the restoring cam pushes the roller upward to cause the transfer lever to pivot counterclockwise slightly until it is latched by the transfer-lever latch.
- (2) The transfer-lever restoring cam is fastened to one end of the function shaft (fig. 26). The function-shaft driving gear on the main shaft and the function-shaft driven gear on the function shaft rotate continuously when the motor is operating. The driven gear rotates freely on the function shaft and the function shaft does

not turn while the Y-levers are being positioned. When the transfer lever moves the T-levers downward to accomplish the transfer operation, the function-clutch latch moves downward also, releasing an arm of the function-clutch drum. This action permits the function-clutch spring to push the function-clutch drum along the function shaft until the teeth of the drum are meshed with the teeth cut into the side of the rotating function-shaft driven gear. The clutch drum is keyed to the flexible-coupling disk, the disk is fastened firmly to the function shaft, and the function shaft rotates whenever the function-clutch drum is pushed against the function-shaft driven gear.

- (3) When a lobe of the transfer-lever restoring cam pushes the transfer-lever roller upward ((1) above), the function-clutch latch also moves upward, into the path of an arm of the function-clutch drum. When the arm of the drum strikes the roller of the function-clutch latch, the drum is cammed away from the teeth of the function-shaft driven gear, and the function shaft stops turning. The shaft remains stationary until another transfer operation occurs after the next code group is received.

d. *Locking Code Rings in Selected Position.* Immediately after the transfer operation occurs, the code-ring locking bail of the TT-4B/TG locks the code rings in their selected positions to prevent movement of the code rings during the printing operation (par. 22). The locking-bail cam on the function shaft (fig. 21) controls operation of the code-ring locking bail as described below.

- (1) When the Y-levers are being positioned, the function shaft and locking-bail cam are stationary, the cam follower is against a lobe of the locking-bail cam, the cam-follower lever is held in the clockwise position, the locking-bail lever is in the counterclockwise position, and the lower end of the code-ring locking bail is held away from the code rings.

s are being
transfer lever
var of ac-
eration, the
ives down-
arm of the
This action
h spring to
drum along
he teeth of
h the teeth
ating func-
The clutch
ole-coupling
rmly to the
action shaft
ction-clutch
e function-

er-lever re-
nsfer-lever
, the func-
es upward,
f the func-
he arm of
ler of the
e drum is
e teeth of
r, and the
ning. The
until an-
ccurs after
ved.

ected Posi-
r operation
f the TT-
ir selected
code rings
22). The
ft (fig. 21)
locking bail

eing posi-
nd locking-
e cam fol-
ne locking-
r lever is
ition, the
e counter-
lower end
il is held

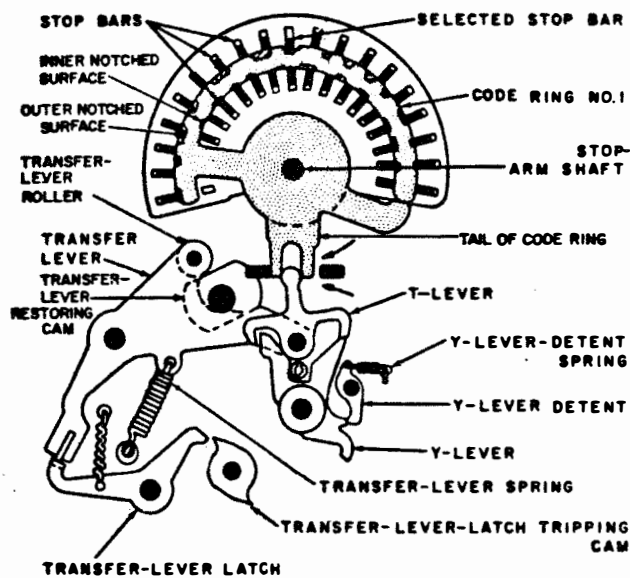

A. T-LEVER AND CODE RING IN MARKING POSITION

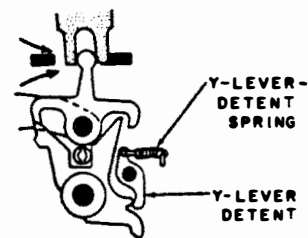

B. T-LEVER AND TAIL OF CODE RING IN SPACING POSITION

TM5815-206-35-100

Figure 20. T-levers and code rings set to marking and spacing positions.

- (2) The locking-bail cam on the function shaft begins to turn after the transfer operation (c(2) above) occurs. The cam follower drops to a low part of the cam, the cam-follower lever pivots counterclockwise, the locking-bail lever pivots clockwise, and the code-ring locking bail moves against the code rings, locking the code rings in position until the opposite lobe of the locking-bail cam moves against the cam follower to release the code rings for the next transfer operation.

e. Sequence of Transfer Operations. The fol-

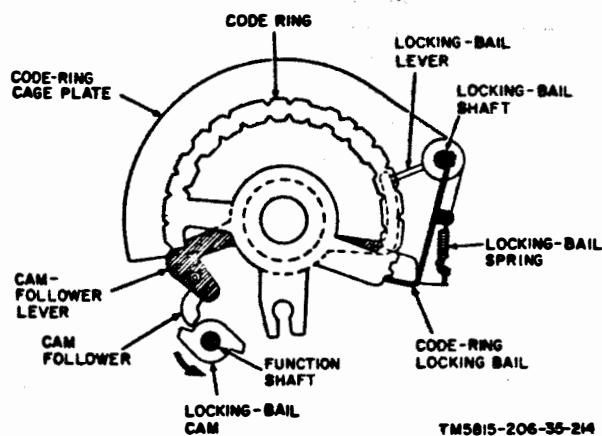

TM5815-206-35-214

Figure 21. Code-ring locking mechanism (TT-4B/TG).

lowing chart lists the sequence of operations that occurs in the page printer immediately after the fifth code impulse is received.

Transfer operation sequence chart

1	Transfer-lever-latch tripping cam pivots transfer-lever latch (fig. 19).	
2	Transfer-lever latch releases transfer lever (fig. 20).	
3	Transfer-lever spring pulls transfer lever clockwise.	
4	Transfer lever moves five T-levers downward (fig. 20).	Function-clutch latch moves downward, releasing function-clutch drum (fig. 26).
5	T-levers transfer settings of Y-levers to code rings.	Function-clutch spring pushes function-clutch drum against function-shaft driven gear.
6	Code rings form groove in line with stop bar to be selected.	Function shaft starts $\frac{1}{2}$ revolution.
7	Stop bar moves into groove in code rings; previously selected stop bar pushed to nonselected position (fig. 22).	Locking-bail cam follower moves to low part of cam: locking bail moves against code rings to lock them in selected position (TT-4B/TG, fig. 21).
8	Selected character printed or function accomplished (par. 22).	
9	Transfer-lever restoring cam on function shaft pivots transfer lever counterclockwise (fig. 20).	Lobe of locking-bail cam pivots cam-follower lever to move locking bail away from code rings (fig. 21).

Transfer operation sequence chart — Continued

10	T-levers move upward, away from Y-levers.	Function-clutch latch moves upward into path of arm on function-clutch drum (fig. 26).
11	Transfer-lever latch locks transfer lever in counterclockwise position (fig. 19).	Function-clutch latch cams function-clutch drum out of engagement with function-shaft driven gear: function shaft stops ($\frac{1}{2}$ revolution completed).

21. Selection of Stop Bars by Code Rings

A stop bar is selected by the code rings immediately after the five code rings are set to the marking or spacing positions as determined by the five code impulses of the received code group (par. 20). Thirty-two of thirty-five stop bars provided are used to control the point at which rotation of the square-shaft stop arm (fig. 19) is halted after each code group is received. The remaining three stop bars (fig. 23) do not affect rotation of the square-shaft stop arm; they activate mechanisms for the line-feed, carriage-return, and figures-shift operations (pars. 24, 26, and 28).

a. Stop-Bar Location. The stop bars are mounted in slots in the code-ring cage. Thirty-two of the stop bars are arranged in pairs in two semicircles, with one outer stop bar and one inner stop bar mounted in each slot. A compression-type stop-bar spring is mounted between each pair of stop bars (fig. 22). The pressure of the springs causes the opposite ends of the 16 outer stop bars to press inward, against the outer surface of the notched, curved portion of the 5 code rings. The same spring pressure causes the 16 inner stop bars to press outward, against the inner, notched surface of the code rings. Each of the 32 possible code combinations (fig. 2) is assigned to one of the 32 stop bars. When a code combination is received, its assigned stop bar is selected by the code rings as described in *b* below.

b. Stop-Bar Selection. The inner and outer surfaces of the curved portion of each of the code rings are notched (figs. 20 and 21). The pattern of notches in each code ring differs from the notch pattern of the other four code rings. When the transfer operation occurs,

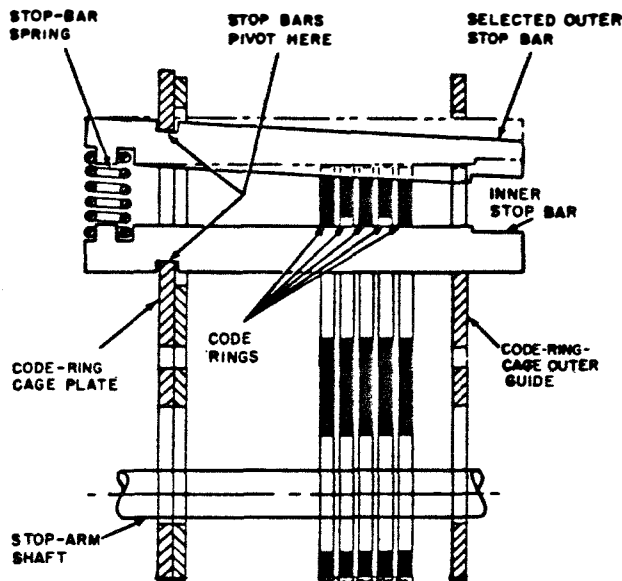

TM 585-206-35-173

Figure 22. Cutaway view of code-ring cage, showing selection of outer stop bar by code rings.

each of the code rings is positioned clockwise or counterclockwise, and the five code rings form a groove in line with one of the stop bars. Pressure of the stop-bar spring causes the stop bar to move into the groove formed by the code rings, and the end opposite the spring moves into the path of one of the projections of the square-shaft stop arm. When the square-shaft stop arm starts rotating, one of its projections strikes against the blocking end of the selected stop bar, and rotation of the stop arm friction-clutch driven is stopped at that point. The point at which the stop arm is halted determines the selection of the character to be printed (par. 22) or the function to be performed (pars. 24-29). Figure 23 illustrates the location of each of the stop bars. The ends of the three extra function stop bars do not project into the path of the square-shaft stop arm and therefore have no control over rotation of the stop arm.

22. Printing Operation

The printing operation occurs immediately after a stop bar is selected by the code rings (par. 21). The printing operation includes selecting the character (*a* below) and printing the selected character (*b* below).

a. Character Selection. Twenty-six type

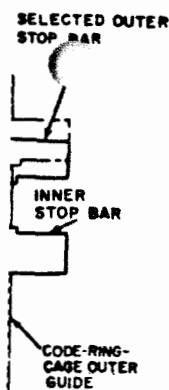

TM 5815-206-35-173
code-ring cage, showing rings.

ed clockwise
code rings
the stop bars.
se the stop
med by the
the spring
projections
the square-
of its pro-
g end of the
he stop arm
that point.
s halted de-
racter to be
to be per-
ustrates the
The ends of
do not pro-
ft stop arm
rotation of

Immediately
code rings
includes se-
printing the

y-s type

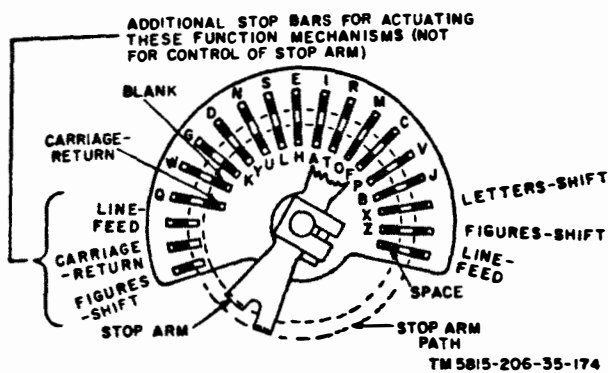

Figure 23. Side view of code-ring cage, showing location of stop bars.

bars and their associated connecting bars are mounted in a semicircle in the carriage of the page printer (figs. 24 and 69). The type-selecting arm is geared to the square shaft and rotates with it (fig. 24). The square shaft starts to turn immediately after the transfer operation occurs and stops when it strikes against the selected stop bar (par. 21). When the selected stop bar halts rotation of the square shaft, it causes one of the fingers of the type-selecting arm to be aligned with one of the 26 connecting bars. The type-selecting arm then pushes the connecting bar forward to cause printing (b below). Power to rotate the square shaft is obtained from the main shaft (c below). Bouncing of the square-shaft stop arm when it strikes the selected stop bar is prevented by the stop-arm antibounce clutch (d below).

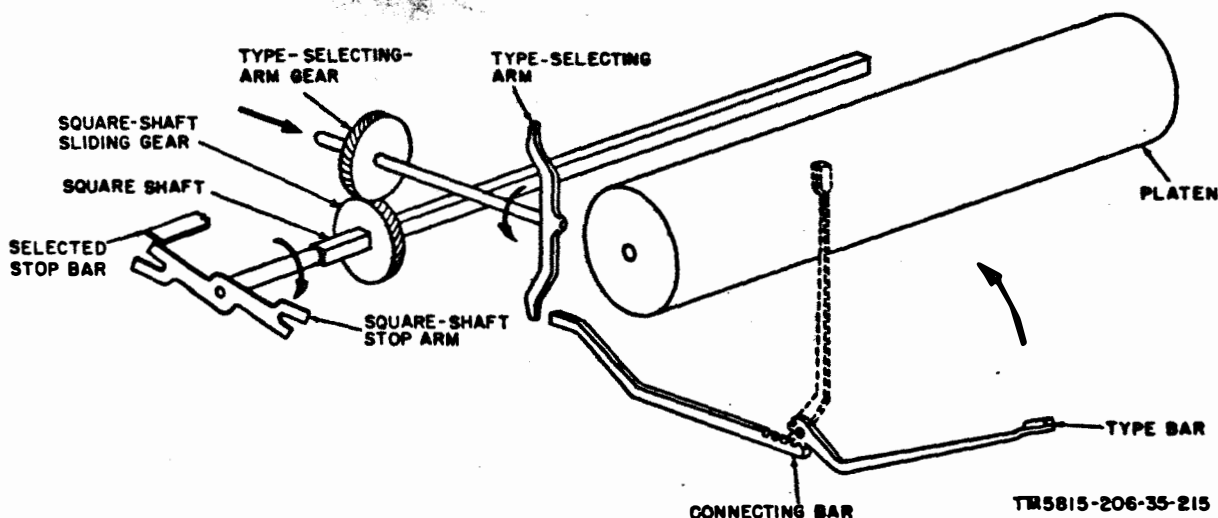

Figure 24. Type bar selection, simplified drawing.

b. Printing of Selected Character. Printing occurs immediately after rotation of the type-selecting arm is halted (a above). A lobe of the print cam (fig. 25) causes the print-cam follower to pivot counterclockwise, causing the print-bail blade to move forward sharply. The print-bail blade is engaged in the groove of the grooved nut on the shaft of the type-selecting arm. The type-selecting arm pushes the aligned connecting bar forward to cause the type bar to strike against the platen. The roller of the print-cam follower then moves to a low portion of the print cam, causing the type-selecting arm to return to the rearward position. The print cam is firmly fastened to the function shaft (fig. 26) and turns $\frac{1}{2}$ revolution each time the transfer-lever latch tripping cam trips the transfer lever (par. 20b).

c. Square-Shaft Rotation. The square shaft does not turn while the code impulses are being received in the page printer and the Y-levers are being positioned. When the last Y-lever is positioned, the transfer-lever-latch tripping cam (fig. 26) trips the transfer-lever latch to start the transfer operation, and the function-clutch latch moves downward (par. 20b). The teeth of the function-clutch drum engage the teeth in the side of the function-shaft driven gear. At this time, the function shaft starts turning because the function-shaft driven gear is in mesh with the constantly rotating function-shaft driving gear on the main shaft. The square-shaft driving gear on the function shaft

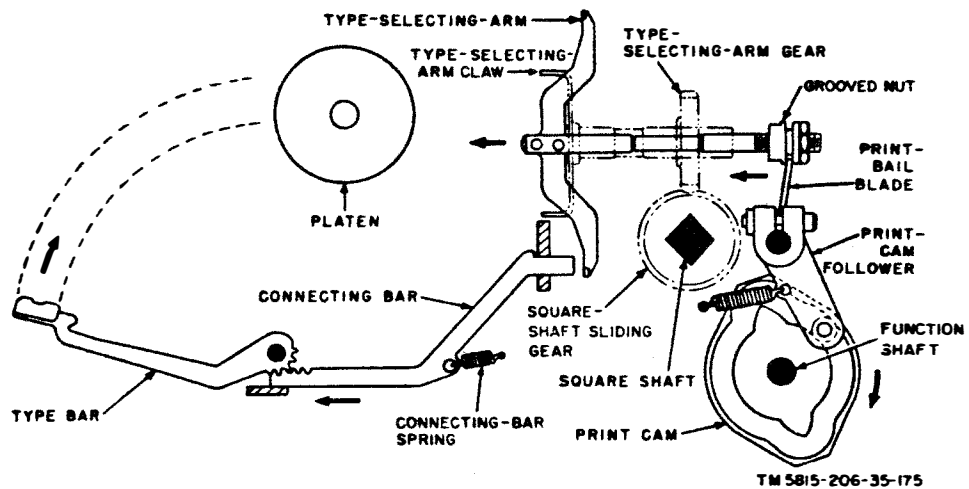

Figure 25. Printing mechanism.

is driven by a friction clutch that includes a clutch disk and a felt friction plate on each side of the gear. When the function shaft turns, the friction clutch causes the square-shaft driving gear to turn the square-shaft driven gear and the square shaft until the stop arm strikes

the selected stop bar. The function shaft continues to turn until the function-clutch drum is cammed away from the function-shaft driven gear by the function-clutch latch which has been moved upward to the latching position by the transfer-lever restoring cam (par. 20c).

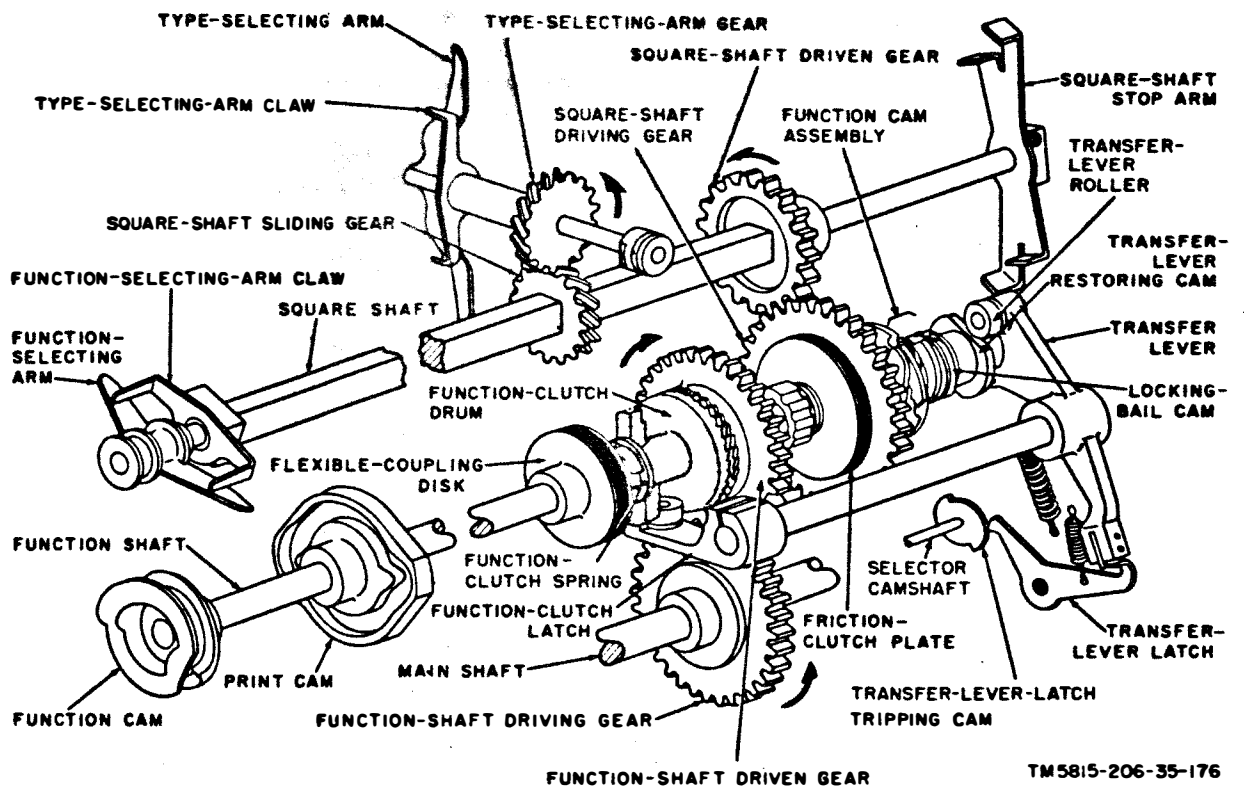
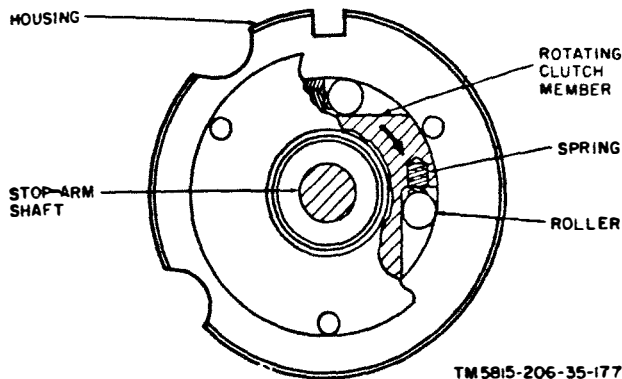

Figure 26. Mechanical power transfer from main shaft to function shaft and square shaft.



TM 5815-206-35-177

Figure 27. Stop-arm antibounce clutch, cutaway view.

d. Stop-Arm Antibounce Clutch. The square-shaft stop arm must not bounce backward when the stop arm strikes the selected stop bar (*b* above). This requirement is necessary because a finger of the type-selecting arm must be in alignment with one of the connecting bars when the type-selecting arm is moved forward to cause printing. Stop-arm bounce is prevented by the antibounce clutch, which consists of the housing, rotating clutch member, four rollers, and four compression-type springs (fig. 27). The housing is pinned to the code-ring cage and cannot rotate. The rotating clutch member is part of the stop-arm shaft and rotates clockwise with the shaft until the stop arm strikes the selected stop bar. Stop-arm bounce (counterclockwise movement of the rotating clutch member) is not possible, because the springs keep the rollers wedged between the flat surfaces of the rotating clutch member and the inner circumference of the housing.

e. Sequence of Printing Operations. The following chart lists the sequence of operations that causes the printing of a character by the page printer.

23. Carriage-Feed Operation

The carriage (fig. 28) moves one space to the right automatically each time a character is printed. The carriage-feed operation causes clockwise rotation of the carriage-rack driving gear, to cause the carriage to move to the right. When a carriage-return code group is received, the carriage-rack driving gear rotates counterclockwise and the carriage moves to the left hand margin (par. 24).

a. Carriage Support. The front of the carriage is supported by the guide rail (17, fig.

Printing operation sequence chart

- | | | |
|---|---|--|
| 1 | As a result of transfer operation (par. 20), selected stop bar moves into groove in code rings; function shaft starts $\frac{1}{2}$ revolution (fig. 26). | |
| 2 | Square-shaft stop arm and type-selecting arm | Print cam starts $\frac{1}{2}$ revolution (fig. 25). |
| 3 | Square-shaft stop arm strikes selected stop bar; type-selecting arm aligned with correct connecting bar. | Lobe of print cam pivots print-cam follower. |
| 4 | Print-bail blade pushes type-selecting arm and connecting bar forward. | |
| 5 | Type bar moves upward to print character. | |
| 6 | Print-cam follower moves against low part of print cam. | |
| 7 | Print-bail blade, type-selecting arm, and connecting bar moved rearward; type bar moves downward. | |
| 8 | Print cam and function shaft complete $\frac{1}{2}$ revolution (fig. 26). | |

85). The rear of the carriage is supported by the square-shaft sliding gear (24, fig. 63), which is in mesh with the type-selecting-arm gear on the rear of the carriage (fig. 25). Two projections of the carriage-support bracket (10, fig. 85) engage the groove in the square-shaft sliding gear, and the gear slides along the length of the square shaft as the carriage moves to the right and left.

b. Carriage-Feed Shaft Assembly. Power to turn the carriage-feed shaft (fig. 28) is obtained from the main shaft (carriage-feed worm in mesh with carriage-feed-shaft gear). When the motor is operating, the fork of the carriage-feed friction clutch and the center clutch disk rotate continuously, exerting a counterclockwise torque against the carriage-feed ratchet, which is firmly fastened to the carriage-feed shaft. When the carriage-feed pawl releases the carriage-feed ratchet (*c* below), the torque of the friction clutch turns the carriage-feed shaft, the drive collar, and the carriage-feed-clutch drum. The carriage-feed driving gear turns counterclockwise to cause the carriage-rack driving gear to turn clockwise to feed the carriage to the right.

c. Carriage-Feed Control. Movement of the carriage-feed pawl is controlled by the carriage-feed link (fig. 28) and the function-selecting arm mechanism (fig. 29).

- (1) The function-selecting arm is attached to the square shaft (fig. 26),

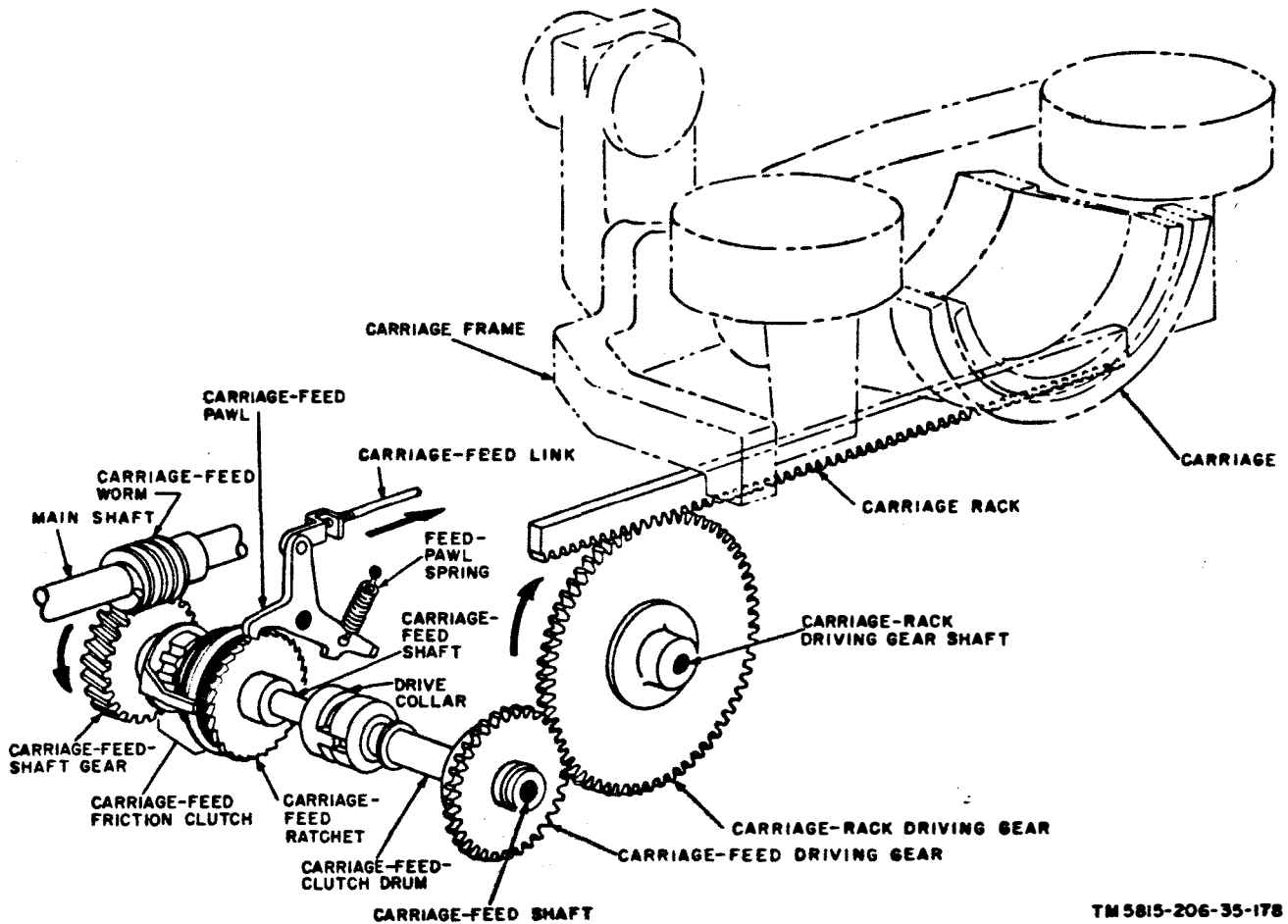

TM 5815-206-35-178

Figure 28. Carriage-feed mechanism.

and rotates and stops with the square-shaft stop arm. The function cam, on one end of the function shaft, starts to turn $\frac{1}{2}$ revolution each time the transfer operation occurs (par. 20b). When a lobe of the function cam pushes the roller end of the function-cam follower (fig. 29), the upper arm of the follower pushes the function-selecting arm toward the punch-bar guide block.

- (a) If one of the fingers of the function-selecting arm is aligned with a slot in the guide block, the function-selecting arm moves *into the slot* and carriage feeding does *not* occur.
- (b) If the finger moves against a solid portion of the guide block, further movement of the function-selecting arm and the upper arm of the function-cam follower is halted. Continued movement of the function-

cam-follower roller to the right causes the support lever to pivot clockwise slightly and the lower arm of the support lever turns the carriage-feed lever counterclockwise, pulling the carriage-feed link horizontally.

- (2) When the carriage-feed link is pulled horizontally (fig. 28), it pivots the carriage-feed pawl slightly. The upper latching arm of the pawl releases the carriage-feed ratchet, the lower latching arm of the pawl moves into the path of the ratchet tooth, and the friction clutch rotates the ratchet slightly until it is stopped by the lower latching arm of the pawl. Continued rotation of the function cam (fig. 29) causes the roller of the function-cam follower to move to a low portion of the cam. The support lever is pulled counterclockwise by its spring, per-

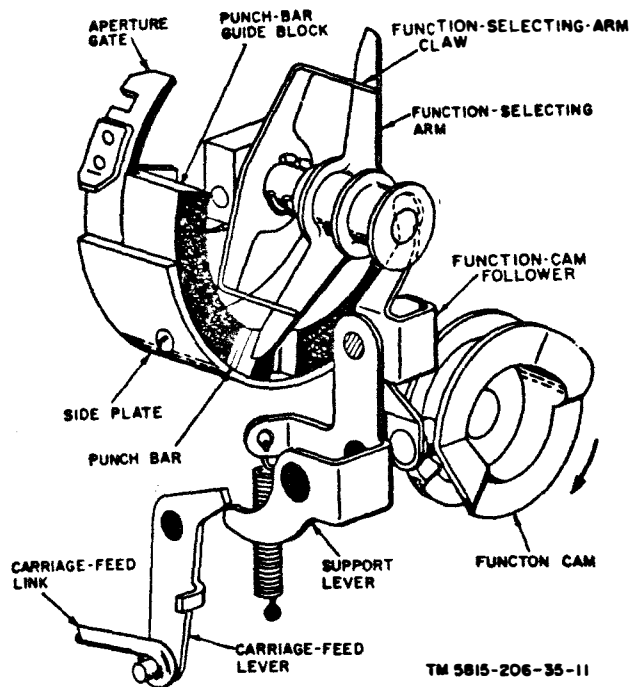

Figure 29. Function-selecting arm and associated mechanism.

mitting the feed-pawl spring (fig. 28) to pull the lower latching arm of the pawl upward, away from the ratchet, and the upper latching arm downward, into the path of the next tooth on the ratchet. The carriage-feed friction clutch again turns the ratchet slightly until it is stopped by the upper latching arm of the pawl.

- (3) Total rotation of the carriage-feed

ratchet during operation of the carriage-feed pawl ((2) above), equals the distance between two teeth of the ratchet. When the ratchet rotates an amount equal to this distance, the carriage-feed driving gear and the carriage-rack driving gear rotate sufficiently to move the carriage one space to the right.

d. *Carriage-Feed Blocking.* When the carriage reaches the right hand margin, carriage feeding is halted by the carriage-feed blocking lever (fig. 30 and 31). The blocking lever is mounted on the carriage-rack driving gear shaft and rotates with the carriage-rack driving gear during carriage feeding. Carriage feeding stops when the arm of the carriage-feed blocking lever moves into the path of the lower arm of the carriage-feed pawl. Under these conditions, the blocking lever prevents the lower latching arm of the carriage-feed pawl from releasing the carriage-feed ratchet until the carriage-return operation occurs (par. 24).

e. *Sequence of Carriage-Feed Operations.* The following chart lists the sequence of operation for carriage feeding.

Carriage-feed operation sequence chart

- | | |
|---|--|
| 1 | Code group received; character selected for printing (par. 22). |
| 2 | Function-cam lobe moves function-cam follower (fig. 29). |
| 3 | Function-cam follower pivots about its upper end (function-selecting arm blocked). |

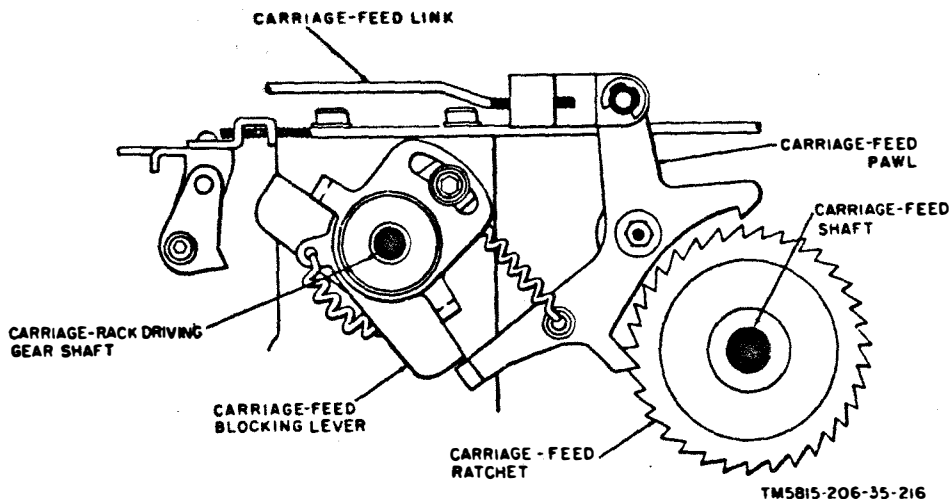
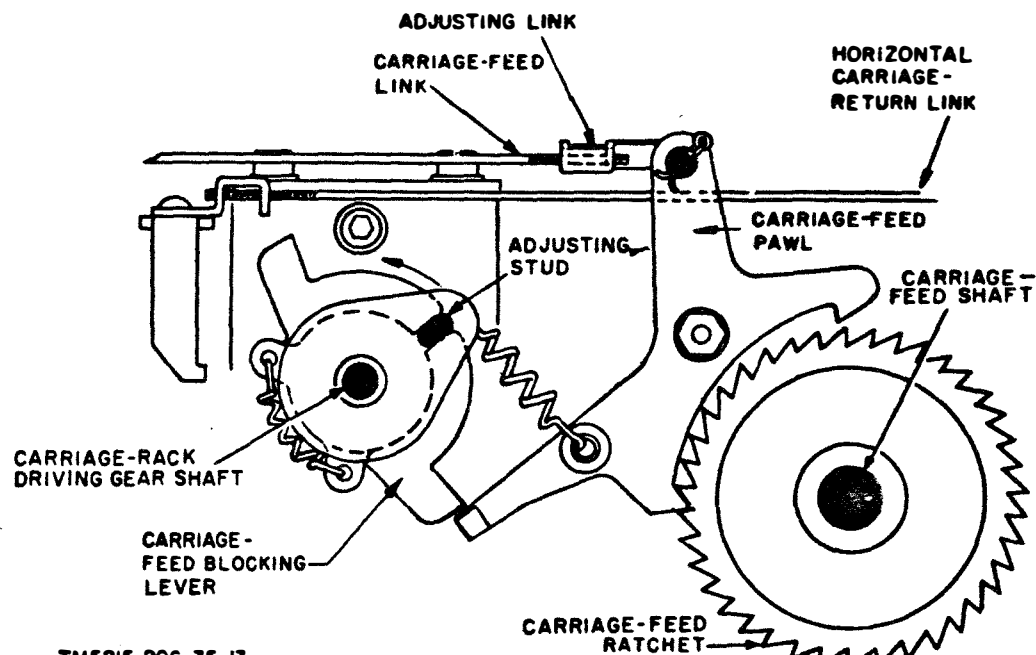

Figure 30. Carriage-feed blocking mechanism, TT-4B/TG.



TM5815-206-35-13

Figure 31. Carriage-feed blocking mechanism, TT-4A/TG.

Carriage-feed operation sequence chart—Continued

4	Support lever pivots clockwise.
5	Carriage-feed lever pivots counterclockwise.
6	Carriage-feed link pulled (fig. 28).
7	Carriage-feed pawl pivots.
8	Carriage-feed ratchet starts turning (friction drive).
9	Carriage moves slightly to right.
10	Function cam restores function-cam follower. (fig. 29).
11	Support lever pivots counterclockwise.
12	Carriage-feed lever pivots clockwise.
13	Carriage-feed link moves horizontally (fig. 28).
14	Carriage-feed pawl upper latching arm moves downward.
15	Carriage-feed ratchet tooth engages carriage-feed pawl.
16	Carriage-feed ratchet wheel held stationary and carriage stopped. (Carriage has moved one space to right.)

24. Carriage-Return Operation

The carriage returns to the left margin when the page printer receives the carriage-return code group (fig. 2) or when the manual carriage-return button on the right side of the page printer is pressed. The carriage-rack driving gear (fig. 28) rotates counterclockwise to move the carriage to the left. This movement is caused by pivoting the carriage-return-clutch lever in the direction shown in B, figures 32 and 33. When the lever pivots as shown, the carriage-return clutch drum engages the constantly rotating carriage-return-

clutch disk (A, figs. 32 and 33) and the carriage-feed-clutch drum is disengaged simultaneously from the carriage-feed driving gear (B, fig. 32 and 33). When the carriage-return clutch members are engaged, the carriage-return driving gear turns clockwise, the carriage-return driven gear and carriage-rack driving gear turn counterclockwise, and the carriage moves to the left.

a. Code Group Selection of Carriage-Return Operation. When the transfer operation (par. 20) occurs after the fifth code impulse of the carriage-return code group is received, the carriage-return stop bar, located between the figures-shift and line-feed stop bars (fig. 23), moves into the groove formed by the code rings. The opposite end of the stop bar moves away from the upper latching arm of the carriage-return sensing lever (fig. 34). The carriage-return sensing-lever cam starts turning when the transfer operation occurs. As a lobe of the cam moves away from the lower arm of the sensing lever, the sensing-lever spring causes the vertical carriage-return link to move upward, moving the horizontal carriage-return link in the direction shown in figure 34 and in A, figures 32 and 33. The horizontal link pulls the double-blocking lever of the TT-4B/TG (B, fig. 32) or the carriage-return operating lever of the TT-4A/TG (B, fig. 33), pivoting the car-

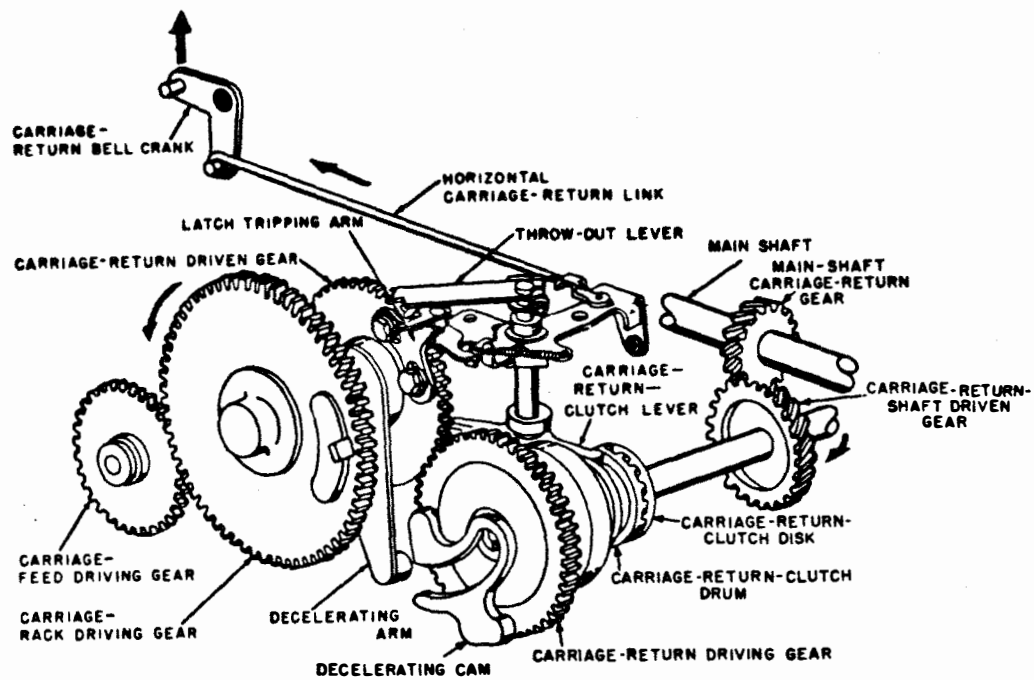

A. CARRIAGE-RETURN DRIVING MECHANISM

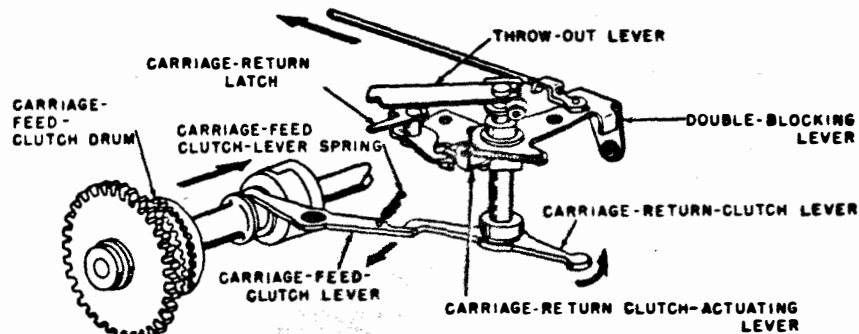

B. DISENGAGEMENT OF CARRIAGE-FEED-CLUTCH DRUM DURING CARRIAGE-RETURN OPERATION

TM5815-206-35-170

Figure 32. Carriage-return mechanism, TT-4B/TG.

carriage-return clutch lever to push the carriage-return clutch drum into engagement with the carriage-return clutch disk. One arm of the carriage-return latch locks the carriage-return-clutch lever in the counterclockwise position until the latch-tripping arm on the carriage-return driven gear pivots the carriage-return latch (c below).

b. *Manual Carriage-Return Operation.* The carriage-return operating lever of the TT-4A/TG (A, fig. 35) and the double-blocking lever of the TT-4B/TG (B, fig. 35) may be moved manually to cause return of the carriage. When the manual carriage-return button on the right side of the page printer is pushed to the left, the manual carriage-return lever pivots counterclockwise and the trip pawl

pushes the carriage-return operating lever of the TT-4A/TG or the double-blocking lever of the TT-4B/TG to start the carriage-return operation.

c. *Completion of Carriage-Return Operation.* The carriage-return-clutch members must remain engaged and the carriage-feed clutch members disengaged (fig. 32 and 33) until the carriage reaches the left margin. This condition is accomplished by keeping the carriage-return-clutch lever (B, fig. 32 and 33) locked in the counterclockwise position ((1) through (3) below) until the carriage reaches the left margin.

- (1) When the rear arm of the carriage-return operating lever of the TT-4A/TG is pulled counterclockwise (B,

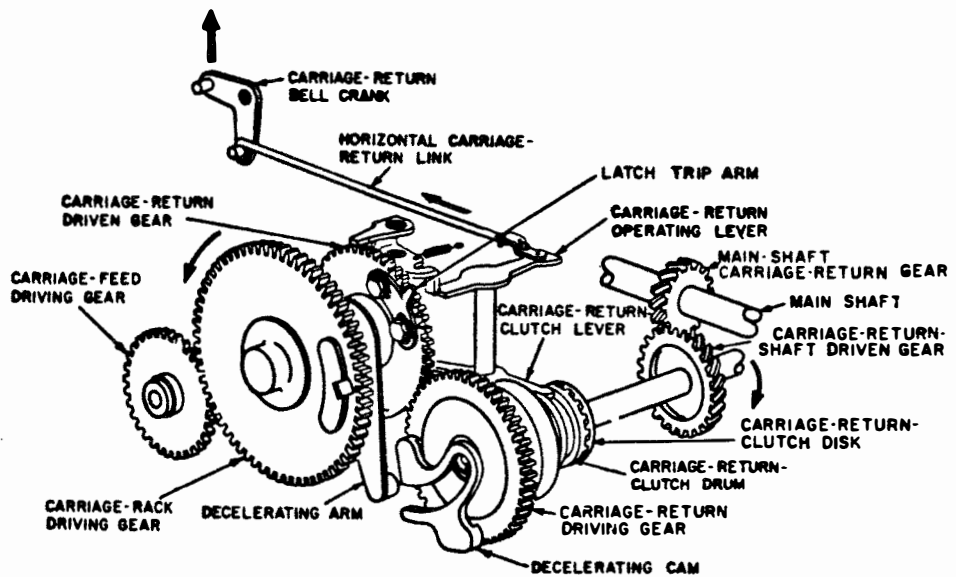

A. CARRIAGE-RETURN DRIVING MECHANISM

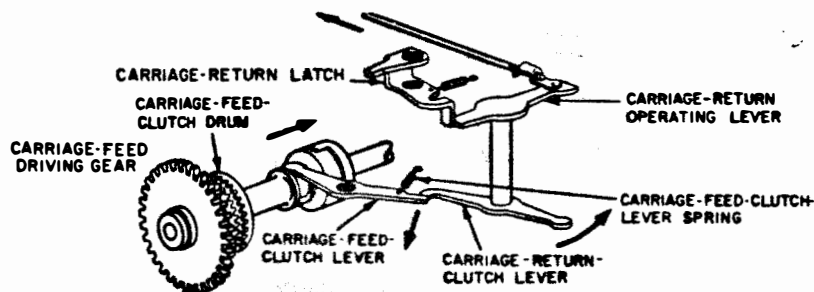

B. DISENGAGEMENT OF CARRIAGE-FEED CLUTCH DRUM DURING CARRIAGE-RETURN OPERATION

TM5815-206-35-14

Figure 33. Carriage-return mechanism, TT-4A/TG.

fig. 33), the carriage-return latch pivots to lock the front arm of the operating lever in the counterclockwise position.

- (2) When the rear arm of the double-locking lever of the TT-4B/TG is moved counterclockwise (B, fig. 32), it pivots the carriage-return clutch-actuating lever counterclockwise also and the actuating lever is locked in this position by the carriage-return latch.
- (3) The carriage-return driven gear rotates counterclockwise during the car-

riage-return operation. When the carriage reaches the left margin, the latch-tripping arm on the carriage-return driven gear pivots the carriage-return latch to release the carriage-return operating lever of the TT-4A/TG and the carriage-return clutch-actuating lever of the TT-4B/TG. Tension of the carriage-feed clutch-lever spring causes the carriage-return-clutch lever to pivot, placing the carriage-return operating lever or the carriage-return-blocking

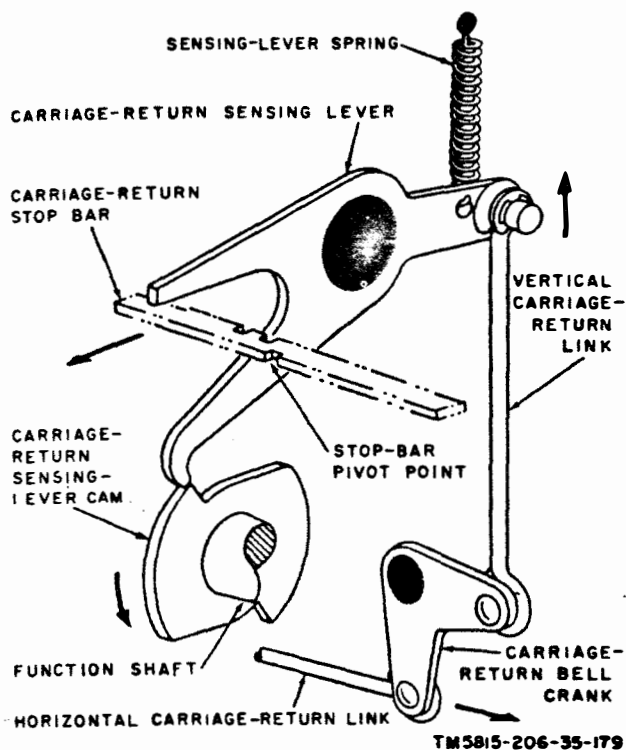

Figure 34. Carriage-return sensing mechanism.

lever in the normal clockwise position. The TT-4B/TG includes a throw-out lever that is fastened to the top of the shaft on which the double-blocking lever is mounted. If, for any reason, the piloting of the carriage-return latch does not cause disengagement of the carriage-return clutch, the latch-tripping arm moves against the throw-out lever to disengage the clutch.

d. Restoring Carriage-Return Sensing Lever. A lobe of the carriage-return sensing-lever cam pushes the carriage-return sensing lever upward (fig. 34) immediately after the carriage starts to move to the left. If the next code group received is not a carriage-return code group, the code rings are repositioned to form a groove in line with a stop bar other than the carriage-return stop bar, and the code-ring end of the carriage-return stop bar is pushed in a direction to cause the opposite end of the stop bar to move under the arm of the carriage-return sensing lever. In this position, the stop bar prevents downward movement of the sensing lever until the next carriage-return code

group is received. When the sensing lever is restored to its upper position, the horizontal carriage-return link moves in a direction opposite to that shown in figures 32 through 34. The carriage-return operating lever of the TT-4A/TG and the double-blocking lever of the TT-4B/TG do not move with the horizontal link because of the latching action of the carriage-return latch (c above). A slot in both levers permits a slight movement to the right of the horizontal link without movement of its associated operating lever or double-blocking lever.

e. Deceleration of Carriage. When the carriage approaches the left margin during the carriage-return operation, the decelerating arm and decelerating cam (A, fig. 32 and 33) slow down movement of the carriage to reduce shock and prevent damage. The decelerating arm is pinned securely to the carriage-return driven gear, and the decelerating cam is bolted to the carriage-return driving gear. The pro-

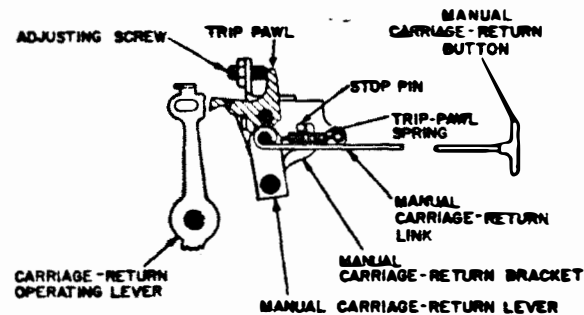

A. TT-4A/TG

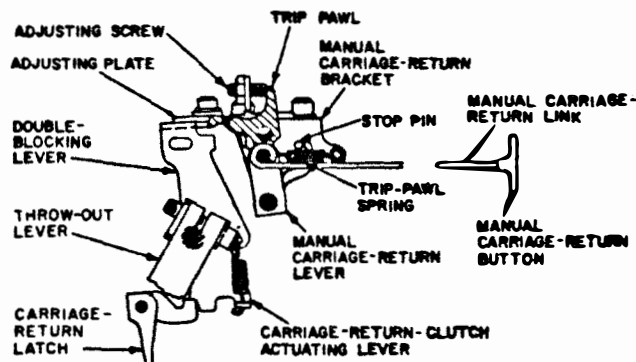

B. TT-4B/TG

TM5815-206-35-17

Figure 35. Manual carriage-return mechanism.

jection on the end of the decelerating arm enters the notch in the cam when the carriage is approximately seven-eighths inch from the left margin. No teeth are provided on that portion of the carriage-return driven gear that would be in mesh with the driving gear when the arm enters the notch in the cam. As the driving gear continues to turn clockwise, the cam raises the decelerating arm to move the carriage to the left margin. As the arm enters deeper into the cam notch, the rate of carriage movement is decreased until the latch-tripping arm on the driven gear causes disengagement of the carriage-return clutch members (c above).

f. Carriage-Return Friction Clutch. The carriage-return driving gear (fig. 33 and 36) is driven by two clutches on the carriage-return shaft. The carriage-return jaw clutch consists of the carriage-return-clutch drum and the carriage-return-clutch disk. The disk rotates continuously when the motor is operating. The clutch drum rotates only when it is moved into engagement with the clutch disk. The carriage-return friction clutch transfers power from the clutch drum to the carriage-return driving gear. The friction clutch is included as a safety feature to prevent equipment damage caused by a sudden stop of the carriage. The spring of the clutch causes the driving gear to be pressed tightly between the clutch sleeve and felt friction plate on one side, and another felt friction plate and a friction disk

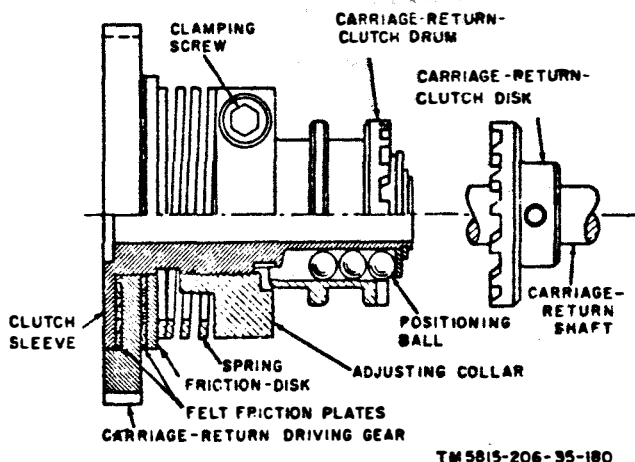

Figure 36. Carriage-return clutches.

on the opposite side. The adjusting collar permits adjustment control of the spring compression to control the amount of torque the clutch supplies before slippage occurs.

g. Carriage-Return Blocking Feature. The carriage-return blocking lever is used to prevent engagement of the carriage-return clutch when the carriage is at the left hand margin and a carriage-return code group is received. The carriage-return blocking lever is mounted on, and rotates with, the carriage-rack driving gear shaft (fig. 38 and 39). When the carriage is at the left-hand margin, the blocking lever blocks movement of the double-blocking lever of the TT-4B/TG (fig. 37) and the carriage-return operating lever of the TT-4A/TG (fig. 38). Under these conditions, the carriage-return-clutch drum (fig. 32 and 33) does not move into engagement with the carriage-return clutch disk.

h. Sequence of Carriage-Return Operations. The sequence of operations that occur when the carriage-return code group is received is described in the following chart.

Carriage-return sequence chart

- | | | |
|----|---|--|
| 1 | Carriage-return code group received; Y-levers positioned accordingly (par. 19a and b). | |
| 2 | Transfer lever released by transfer-lever latch (par. 20). | |
| 3 | Code rings form grooves for carriage-return stop bars (par. 21). | Function shaft starts revolving. |
| 4 | Carriage-return stop bars moved into grooves. | Lobe of carriage-return sensing-lever cam moves past carriage-return sensing lever (fig. 34). |
| 5 | Carriage-return sensing lever moves downward. | |
| 6 | Vertical carriage-return link moves upward. | |
| 7 | Carriage-return bell crank pivots. | |
| 8 | Horizontal carriage-return link moves to left (fig. 32 and 33). | |
| 9 | Double-blocking lever of TT-4B/TG pivots; carriage-return clutch-actuating lever latched by carriage-return latch. Carriage-return latch engages carriage-return operating lever of TT-4A/TG. | |
| 10 | Carriage-return-clutch lever pivots; carriage-feed-clutch lever pivots. | Carriage-return sensing lever raised by carriage-return sensing-lever cam (fig. 34). |
| 11 | Carriage-return-clutch drum engages clutch disk; carriage-feed-clutch drum moves away from carriage-feed driving gear. | Carriage-return bell crank pivots and horizontal carriage-return link moves to left (fig. 34). |

g collar per-
ing mpres-
ue the clutch

eature. The
used to pre-
return clutch
and margin
is received.
is mounted
rack driving
the carriage
locking lever
king lever of
carriage-re-
4A/TG (fig.
carriage-re-
3) does not
carriage-re-

Operations.
occur when
received is

levers posi-

latch (par. 20).
aft starts

riage-return
ver cam moves
age-return
ver (fig. 34).
nward.
ard.

o left (fig.

vots; carriage-
y carriage-
gages car-
/TG.
rn sensing
d by carriage-
ing-lever cam

rn bell crank
horizontal
urn link
ft (fig. 34).

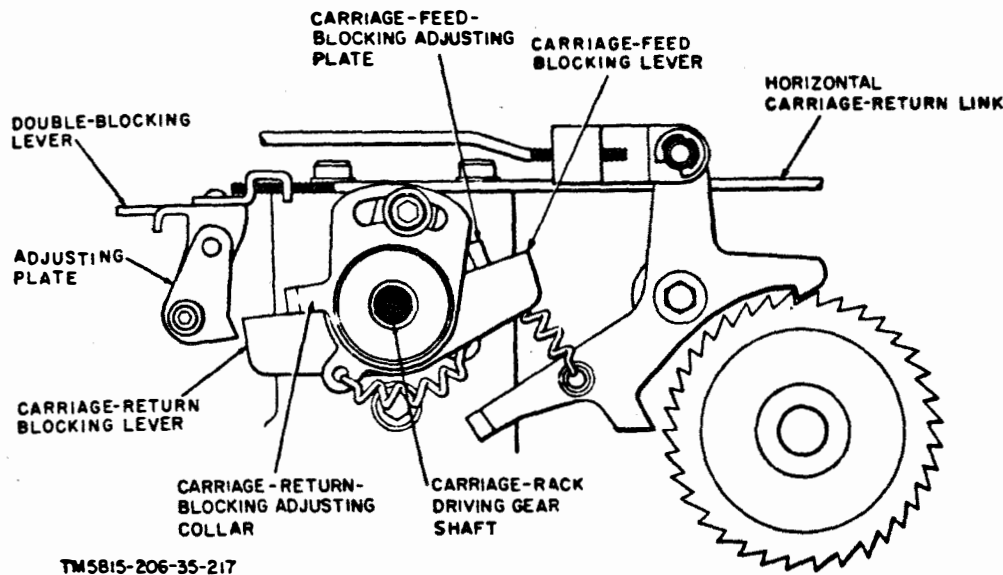

TM5815-206-35-217

Figure 37. Carriage-return blocking mechanism, TT-4B/TG.

Carriage-return sequence chart — Continued

12	Carriage-return driving gear turns carriage-return driven gear and carriage-rack driving gear; carriage moves to left; carriage-feed driving gear idles (fig. 32 and 33).	Function shaft stops after completing $\frac{1}{2}$ revolution.
13	Carriage nears left margin.	Carriage-return stop bar latches carriage-return sensing lever when next code group is received (par. 33b).
14	Decelerating arm engages decelerating cam. (fig. 32 and 33).	
15	Carriage-return driven gear teeth clear carriage-return drive gear teeth.	
16	Carriage decelerates as it reaches left margin.	
17	Latch-tripping arm strikes carriage-return latch.	
18	Carriage-return latch releases carriage-return-clutch actuating lever or TT-4B/TG or carriage-return operating lever of TT-4A/TG.	Latch-tripping arm of TT-4B/TG contacts throw-out lever.
19	Carriage-feed-clutch spring pulls carriage-feed-clutch lever and carriage-return-clutch lever.	
20	Carriage-return clutch drum moves away from carriage-return-clutch disk.	Carriage-feed clutch drum moves into engagement with carriage-feed driving gear.
21	Carriage stopped at left margin.	

25. Margin-Bell Operation

The margin bell rings automatically to warn the operator that the carriage of the page printer is six spaces from the right margin. During carriage feeding (par. 23), the carriage-rack driving gear rotates clockwise to move the carriage to the right, and the pawl tripping arm, attached to the carriage-rack driving gear (fig. 39), rotates with the gear. As the carriage nears the right margin, the pawl tripping arm lifts the margin-bell pawl; this causes the margin-bell clapper to pivot counter-clockwise. Further rotation of the gear causes the pawl to slip past the pawl tripping arm and the clapper spring pulls the clapper upward sharply to strike the margin bell. During the carriage-return operation (par. 24), the carriage-rack driving gear rotates counter-clockwise. The pawl tripping arm moves downward, pivoting the pawl until the tripping arm moves beyond the pawl and the pawl spring pulls the pawl to the normal (upper) position.

26. Figures-Shift Operation

Twenty-four of the type bars in the page printer print a letter when the platen is in the letters-shift (lower) position and print a numeral or punctuation mark when the platen is in the figures-shift (upper) position (fig. 2). Printing does not occur when either the

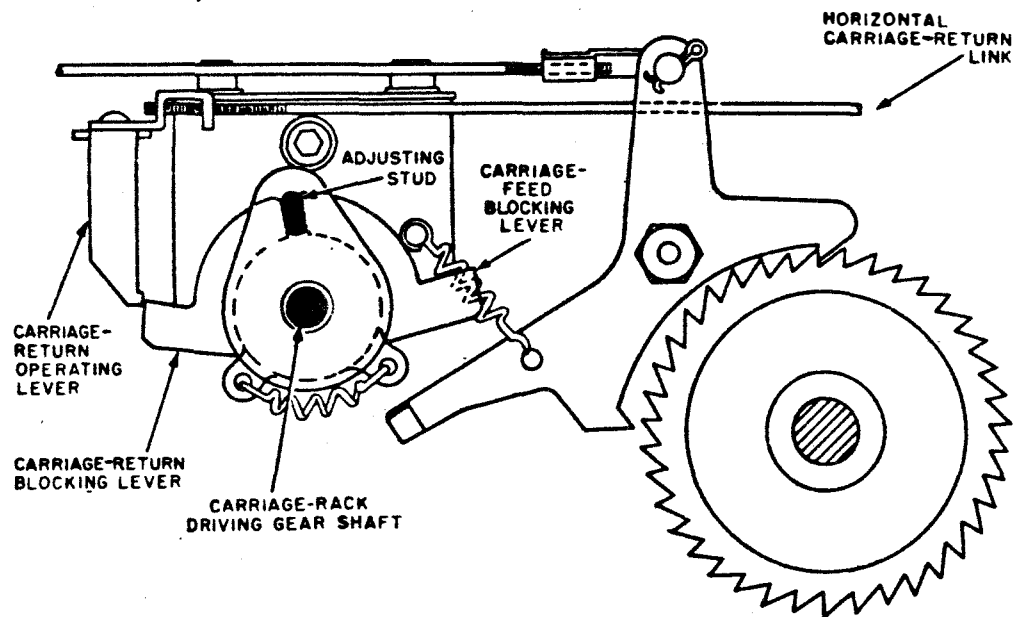

TM5815-206-35-18

Figure 38. Carriage-return blocking mechanism TT-4A/TG.

letter S or the letter H code group is received while the platen is in the figures-shift position (par. 31 and 32). The platen is moved to the figures-shift position as described below.

a. Selecting Figures-Shift Operation. The figures-shift code group must be received by the page printer to cause the platen to move to the figures-shift position. When the transfer operation occurs (par. 20), the code rings are positioned to form a groove in line with each of *two* figures-shift stop bars (fig. 23). Each stop bar moves into its associated groove.

(1) When the outer end of the figures-shift stop bar that is mounted next to the carriage-return stop bar (fig. 23)

moves into its groove, the inner end of the stop bar moves *away* from the latching arm of the figures-shift sensing lever (fig. 40). When the stop bar is in this position, the sensing lever is free to follow the contour of the figures-shift sensing-lever cam when the cam rotates (*b* below).

(2) When the outer end of the figures-shift stop bar, which shares a slot in the code-ring cage with the stop bar for the letter Z, moves into its groove in the code rings, it moves into position to stop rotation of the square-shaft stop arm. When the square-shaft stop arm strikes the stop bar, the following action occurs:

- (a) The type-selecting arm stops at a point where it is *not* aligned with a connecting bar and no symbol is printed by the page printer when the type-selecting arm is moved forward by the print-bail blade (par. 22).
- (b) The function-selecting arm stops at a point adjacent to a notch in the punch-bar-guide block (fig. 49). When stopped at this point, carriage-feeding (par. 23) is prevented and the carriage remains

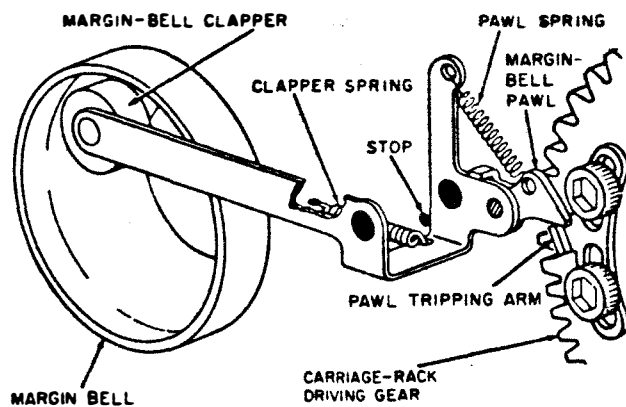

TM5815-206-35-181

Figure 39. Margin-bell mechanism.

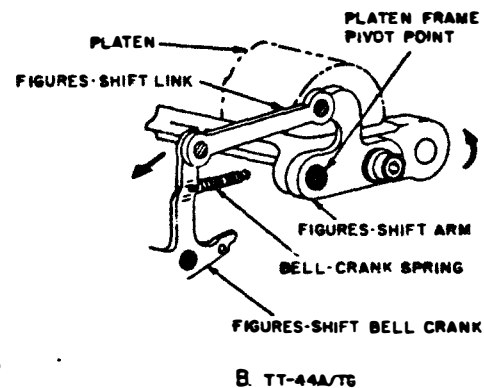
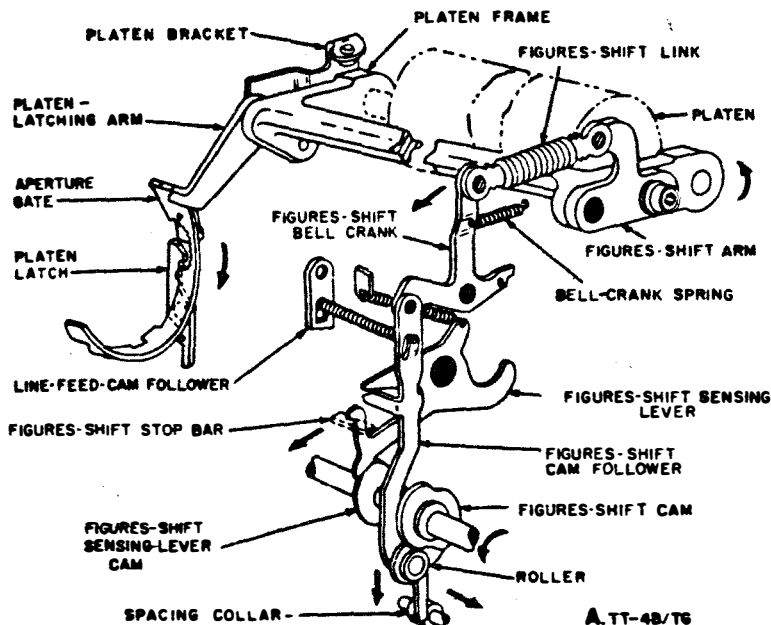

Figure 40. Figures-shift mechanism.

TM5815-206-35-19

6-35-18

the inner end way from the res-shift sens- when the stop, the sensing the contour of ng-lever cam below).

the figures-shift a slot in the stop bar for its groove in es into posi- f the square- e square-shaft o bar, the fol-

m stops at a aligned with a no symbol is printer when is moved for- l blade (par.

arm stops at notch in the k (fig. 49). s point, car- 23) is pre- ag remains

motionless when the platen is moved upward to the figures-shift position.

b. Moving Platen to Figures-Shift Position. The figures-shift sensing-lever cam starts turning when the transfer operation occurs (par. 20). Tension of the sensing-lever spring causes the figures-shift sensing lever to move downward when a low part of the cam moves adjacent to the sensing lever. The upper arm of the sensing lever also moves downward against the slanted portion of two projections of the figures-shift-cam follower. Continued downward movement of the sensing lever causes the lower end of the figures-shift-cam follower to move horizontally until the roller attached to the lower end of the follower is under the figures-shift cam. Continued rotation of the function shaft causes a lobe of the figures-shift cam to push the cam follower downward. The figures-shift bell crank pivots counterclockwise, pulling the figures-shift link in the direction shown in figure 40. The platen frame pivots counterclockwise, moving the platen upward to the figures-shift position. The platen is locked in *d* below.

c. Releasing Platen Lower-Case Latch (TT-4B/TG Only). The platen-blocking arm and the platen lower-case latch (fig. 41) are used to lock the platen of the TT-4B/TB in the

letters-shift position until the figures-shift sensing lever moves to a low portion of its cam (*b* above). When the sensing lever pivots, the curved arm of the sensing lever moves upward against one arm of the platen lower-case latch. The upper arm of the latch moves away from the latching end of the platen-blocking arm, and the arm is free to move downward when the platen (on the opposite side of the platen-frame pivot point) moves upward.

d. Latching Platen in Figures-Shift Position. When the platen frame pivots to move the platen upward, one end of the platen-latching arm (A, fig. 40) moves downward; this causes the aperture gate to move in the direction indicated. When the gate is moved to this position, the platen latch (fig. 42) engages a projection of the gate to lock the platen-latching arm in the lower position, and the platen in the figures-shift position.

e. Sequence of Figures-Shift Operations. The following chart lists the sequence of operations that occur when the page printer receives the figures-shift code group.

Figures-shift operation sequence chart

- | | |
|---|--|
| 1 | Figures-shift code group received; Y-levers positioned accordingly (par. 19a and b.) |
| 2 | Transfer-lever-latching cam trips transfer-lever latch (par. 20). |

Figures-shift operation sequence chart—Continued

3	T-levers and code rings positioned for figures-shift selection.	Function-clutch drum released by function-clutch latch (fig. 26).
4	Code rings form groove in line with both figures-shift stop bars.	Function-clutch drum pushed into engagement with function-shaft driving gear by function-clutch spring.
5	Figures-shift stop bars move into grooves in code rings.	Function shaft and square shaft start turning.
6	Figures-shift sensing lever moves to low part of figures-shift sensing-lever cam (fig. 40).	Square shaft rotates until square-shaft stop arm strikes figures-shift stop bar.
7	Figures-shift sensing lever moves lower end of figures-shift-cam follower toward figures-shift cam.	Curved arm of figures-shift sensing lever pivots platen lower-case latch (TT-4B/TG) (fig. 41).
8	Roller of figures-shift-cam follower moves under figures-shift cam.	Upper arm of platen lower-case latch moves away from platen-blocking arm (TT-4B/TG).
9	Lobe of rotating figures-shift cam pushes figures-shift-cam follower downward.	
10	Figures-shift bell crank pivots, pulling figures-shift link rearward.	
11	Platen frame pivots; platen moved upward to figures-shift position.	
12	Platen-latching arm and aperture gate move downward; latched in lower position by platen latch.	Platen-blocking arm moves downward, below latching surface of platen lower-case latch (TT-4B/TG) (fig. 41).
13	Lobe of figures-shift sensing-lever cam pivots figures-shift sensing lever to original position (fig. 40).	
14	Lower end of figures-shift-cam follower moves away from figures-shift cam.	Arm of function-clutch drum strikes function-clutch latch, drum moves away from function-shaft driving gear; function shaft stops turning (fig. 26).

27. Letters-Shift Operation

When the letters-shift code group is received, the letters-shift mechanism moves the platen to the letters-shift (lower) position as described below.

a. Selecting Letters-Shift Operation. When the letters-shift code group is received (all five code impulses marking), the five Y-levers are set to the marking position. When the transfer operation (par. 20) occurs:

- (1) The code rings are positioned to form a groove into which the letters-shift stop bar moves (fig. 23).
- (3) The square shaft rotates until the square-shaft stop arm strikes the letters-shift stop bar. When this occurs:
 - (a) The function-selecting arm stops at a point where it is aligned with the letters-shift punch bar in the punch-bar guide block (fig. 29).
 - (b) The type-selecting arm stops at a point where it is *not* aligned with a connecting bar. No symbol is printed by the page printer when the letters-shift code group is received.

b. Moving Platen to Letters-Shift Position. Immediately after the function-selecting arm is stopped at a point where it is aligned with the letters-shift punch bar, a lobe of the function cam (fig. 29) causes the function-cam follower to pivot counterclockwise. The top of the function-selecting cam follower causes the function-selecting arm to push the letters-shift punch bar toward the center of the page printer (fig. 42). This action causes the letters-shift lever to pivot counterclockwise. The platen latch pivots clockwise, releasing the aperture gate. The weight of the platen causes it to move downward. The platen-latching arm and aperture gate move upward where they remain until the next figures-shift code group is received.

c. Locking Platen in Letters-Shift Position. When the platen moves downward to the letters-shift position (*b* above), the latching end of the platen-blocking arm (fig. 41) moves upward. The platen-blocking arm is held in the upper position by the platen lower-case latch until the next figures-shift code group received causes the curved arm of the figures-shift sensing lever to pivot the platen lower-case latch counterclockwise when the platen is to be raised to the figures-shift position (par. 26*b*).

d. Sequence of Letters-Shift Operations. The following chart lists the sequence of operations that occur when the letters-shift code group is received by the page printer.

oned to form
letters-shift

es until the
rikes the let-
this occurs:
arm stops at
aligned with
bar in the
(fig. 29).

l stops at a
lined with a
symbol is
printer when
group is

ift Position.
lecting arm
aligned with
of the func-
tion-cam fol-
lower top of the
causes the
letters-shift
page printer
letters-shift
The platen
the aperture
es it to move
m and aper-
they remain
e group is

ift Position.
l to the let-
atching end
) moves up-
held in the
r-case latch
oup received
s-shift sens-
r-case latch
n is to be
par. 26b).

Operations.
ce of opera-
s-shift code

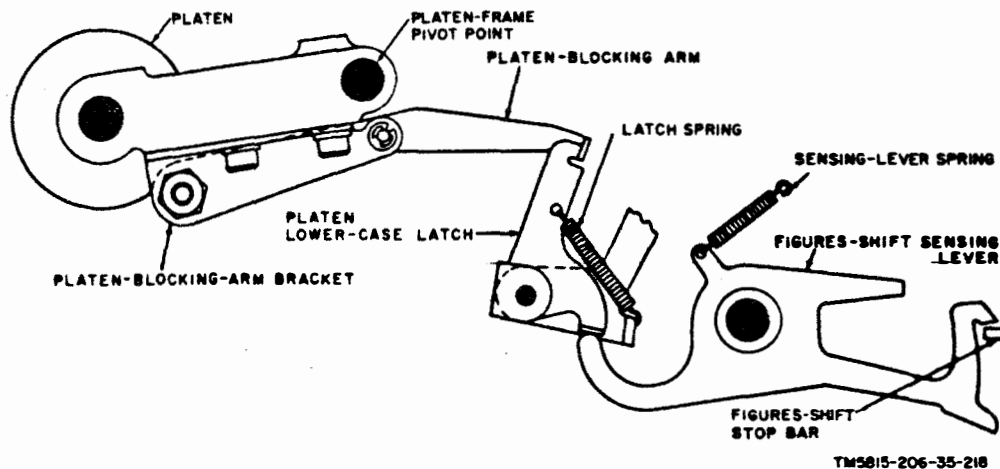

Figure 41. Platen-blocking mechanism.

Letters-shift operation sequence chart

1	Letters-shift code group received; Y-levers positioned accordingly (par. 19a and b).	
2	Transfer-lever-latching tripping cam trips transfer-lever latch (par. 20).	
3	T-levers and code rings positioned for selection of letters-shift operation.	Function-clutch drum released by function-clutch latch (fig. 26).
4	Code rings form groove in line with letters-shift stop bar.	Function-clutch drum pushed into engagement with function-shaft driving gear by function-clutch spring.
5	Letters-shift stop bar moves into groove in code rings.	Function shaft and square shaft start turning.
6	Square shaft rotates until square-shaft stop arm strikes letters-shift stop bar; finger of function-selecting arm aligned with letters-shift punch bar in punch-bar guide block.	
7	Lobe of function cam pivots function-cam follower counterclockwise (fig. 29).	
8	Function-selecting arm pushes letters-shift punch bar toward center of page printer (fig. 42).	
9	Letters-shift lever pivots counterclockwise; platen latch pivots clockwise.	
10	Gravity causes platen to move to letters-shift position; platen-latching arm and aperture gate move upward.	
11	Platen-blocking arm of TT-4B/TG moves upward; locked in upper position by platen lower-case latch (fig. 41).	
12	Low portion of function cam pivots function-cam follower clockwise (fig. 29).	
13	Function-selecting arm moves away from letters-shift punch bar.	
14	Spring pulls platen latch counterclockwise, letters-shift lever pivots clockwise; letters-shift punch bar moves to the right to the unoperated position.	
15	Arm of function-clutch drum strikes function-clutch latch; drum moves away from function-shaft driving gear. Function shaft stops turning (fig. 26).	

28. Line Feed Operation

The line-feed mechanism (fig. 43) is used to turn the platen one or two line spaces when the line-feed code group is received. The position of the single-double line-feed lever determines the amount of platen rotation (fig. 44).

a. *Selecting Line Feed Operation.* When the line-feed code group is received by the page printer, the five Y-levers are positioned in ac-

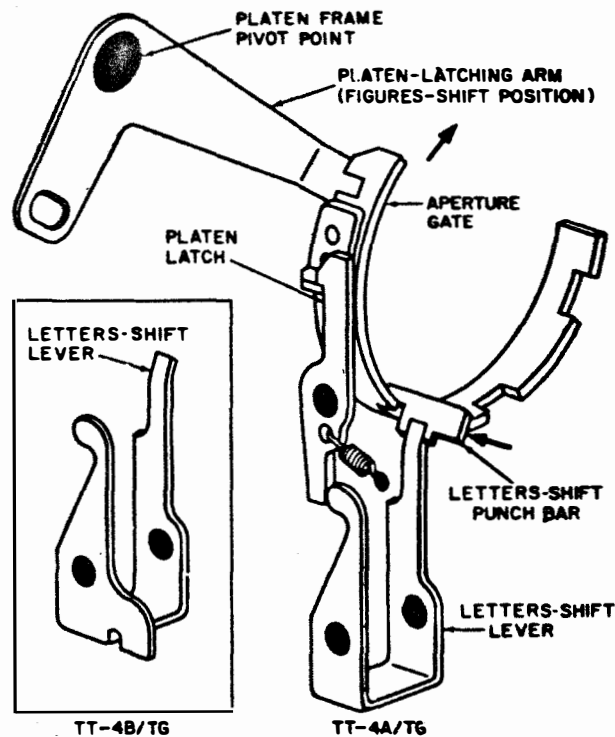
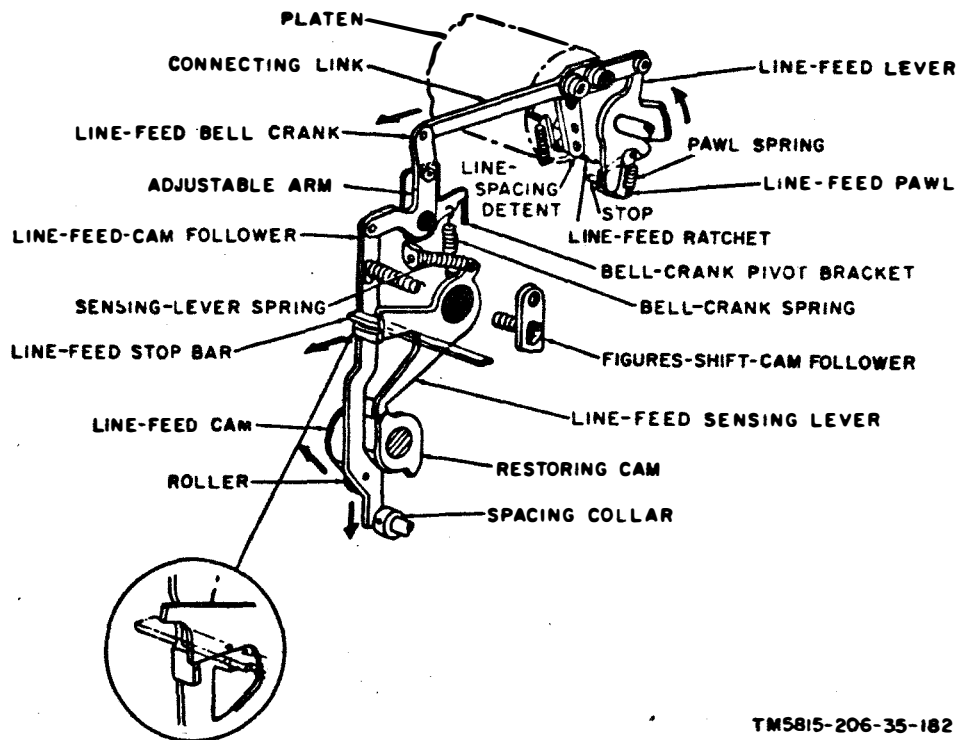

Figure 42. Letters-shift mechanism.



TM5815-206-35-182

Figure 43. Line-feed mechanism.

cordance with the code impulses of the code group (fig. 2). After the fifth Y-lever is positioned, the transfer operation occurs (par. 20). The code rings are positioned to form a groove in line with each of two line-feed stop bars (fig. 23). Each stop bar moves into its associated groove.

- (1) When the outer end of the line-feed stop bar that is mounted between the carriage-return stop bar and the letter Q stop bar moves into its groove in the code rings, the inner end of the stop bar moves away from the upper arm of the line-feed sensing lever (fig. 43). When the stop bar is in this position, the sensing lever is free to follow the contour of the line-feed sensing-lever cam when the cam rotates (b below).
- (2) When the outer end of the line-feed stop bar that shares a slot in the code ring cage with the stop bar for the space code group (fig. 23) moves into its groove, it moves into position to stop rotation of the square-shaft stop arm. When the square-shaft stop arm

strikes the stop bar; the following action occurs:

- (a) The type-selecting arm stops at a point where it is *not* alined with a connecting bar and no symbol is printed by the page printer when the type-selecting arm is moved forward by the print-bail blade (par. 22).
- (b) The function-selecting arm stops at a point adjacent to a notch in the punch-bar-guide block (fig. 49). When stopped at this point, carriage-feeding (par. 23) is prevented and the carriage remains motionless when the line-feed operation occurs.

b. Rotating Platen. The line-feed sensing-lever cam and line-feed cam on the function shaft (fig. 43) starts turning at the same time that the transfer operation occurs (par. 20). Tension of the sensing-lever spring causes the line-feed sensing lever to move downward when a low part of the cam moves adjacent to the sensing lever. The upper arm of the sensing lever moves past the line-feed stop

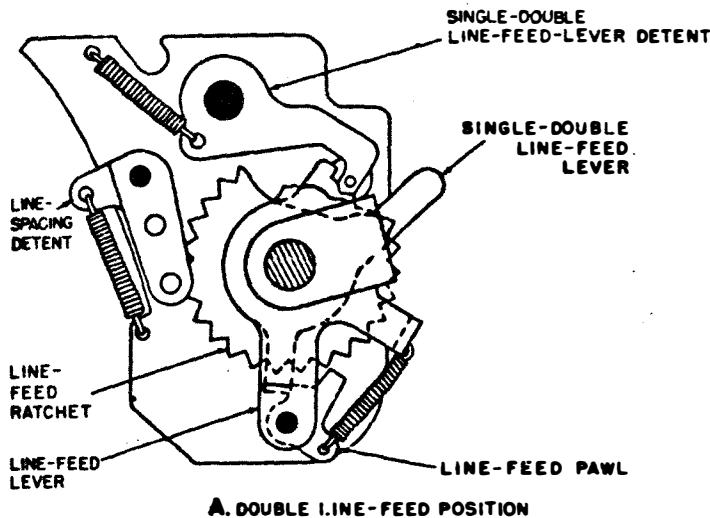

A. DOUBLE LINE-FEED POSITION

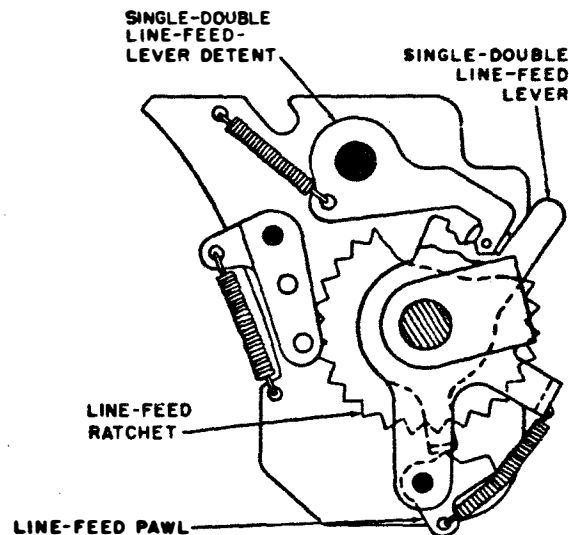

B. SINGLE LINE-FEED POSITION

TM5815-206-35-1B3

Figure 44. Positions of single-double line-feed lever.

bar and strikes the slanted portion of two projections of the line-feed-cam follower. Continued downward movement of the sensing lever causes the lower end of the cam follower to move horizontally until the roller attached to the lower end of the cam follower is under the line-feed cam. Continued rotation of the function shaft causes a lobe of the line-feed cam to push the cam follower downward. The line-feed bell crank pivots, pulling the line-feed connecting link rearward; this causes the line-feed lever to pivot counterclockwise. The line-feed pawl, attached to the lower arm of the line-feed lever, moves upward, engages a tooth of the line-feed ratchet, and turns the ratchet and the platen counterclockwise. The line-spacing detent prevents rotation of the platen while the page printer prints a line of copy. When the single-double line-feed lever is in the single line-feed position (B, fig. 44), the line-feed pawl passes the nearest tooth of the detent, engages the next tooth, and then rotates the platen the width of one detent tooth. When the single-double line-feed lever is in the double line-feed position (A, fig. 44), the pawl engages the nearest tooth and the platen rotates the width of two line spaces.

c. *Sequence of Line-Feed Operations.* The following chart lists the sequence of operations that occur when the page printer receives the line-feed code group.

Line-feed operation sequence chart

1	Line-feed code group received; Y-levers positioned accordingly (par. 19a and b).	
2	Transfer-lever-latch tripping cam trips transfer-lever-latch (par. 20).	
3	T-levers and code rings positioned for selection of line-feed operation.	Function-clutch drum released by function-clutch latch (fig. 26).
4	Code rings form groove in line with both line-feed stop bars.	Function-clutch drum pushed into engagement with function-clutch driving gear.
5	Line-feed stop bars move into grooves in code rings.	Function shaft and square-shaft start turning.
6	Line-feed sensing lever moves to low part of line-feed sensing-lever cam (fig. 43).	Square shaft rotates until square-shaft stop arm strikes line-feed stop bar.
7	Line-feed sensing lever moves lower end of line-feed-cam follower toward line-feed-cam; roller on cam follower moves under cam.	
8	Lobe of line-feed cam pushes line-feed-cam follower downward.	
9	Line-feed bell crank pivots, pulling line-feed connecting link rearward.	
10	Line-feed lever pivots counterclockwise.	
11	Line-feed pawl engages line-feed ratchet; ratchet moves one or two line spaces.	
12	Lobe of line-feed sensing-lever cam pushes line-feed sensing lever upward.	
13	Lower end of line-feed-cam follower moves away from line-feed cam.	Arm of function-clutch drum strikes function-clutch latch; drum moves away from function-shaft driving gear; function shaft stops turning (fig. 26).

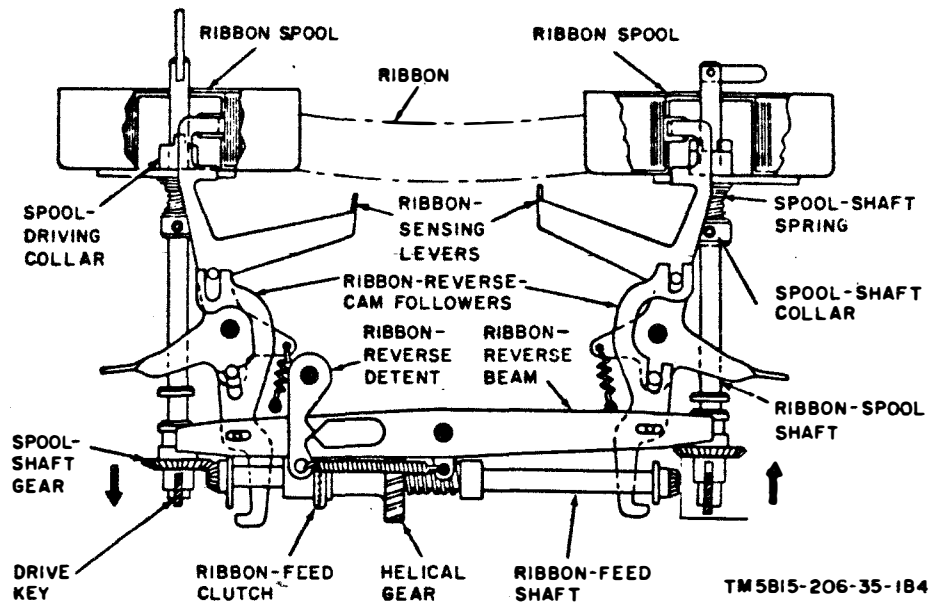

Figure 45. Ribbon-feed mechanism positioned for feeding ribbon from right ribbon spool to left ribbon spool.

29. Ribbon Feed and Ribbon Reverse Operations

Two ribbon spools and enough ribbon to fill one of the spools are mounted on the carriage (fig. 45). During operation of the page printer, one of the spools turns slowly to pull the ribbon from the opposite spool (*a* below). When the ribbon is almost completely wound on one spool, the ribbon-reverse operation (*b* below) reverses the direction of ribbon feed.

a. Ribbon-Feed Operation.

- (1) Each end of the ribbon is attached to the hub of a ribbon spool which is mounted on the upper end of a ribbon-spool shaft. Two slotted spool-shaft gears are mounted on the lower end of the ribbon-spool shafts. The slots in each gear engage a drive key that is fastened to the bottom of the shaft and the shaft turns whenever the gear is turned.
- (2) Teeth of the helical gear on the ribbon-feed shaft engage teeth of the carriage-guide rail (17, fig. 85), and when the carriage feeds to the right, the helical gear moves from one tooth of the guide rail to the next tooth, rotating slightly with each movement. The ribbon-feed clutch is used to cause the ribbon-feed shaft to rotate

with the helical gear as the carriage moves to the right.

b. Ribbon-Reverse Operation. The ribbon-reverse beam, ribbon-reverse cam, ribbon-reverse cam follower, and ribbon-sensing lever on each side of the ribbon-feed mechanism (fig. 45) are used to reverse the direction of ribbon feed.

- (1) When the left end of the beam is in the downward position, the left spool-shaft gear is in mesh with its associated bevel gear on the end of the ribbon-feed shaft. Operation of the page printer causes the left ribbon spool to rotate, pulling the ribbon from the ribbon spool on the right side of the ribbon-feed mechanism.
- (2) When the final turn of ribbon is being unwound from the right ribbon spool, the upper end of the right ribbon-sensing lever (fig. 46) moves to the left, through an opening in the hub of the ribbon spool. The lower end of the cam follower moves under the ribbon-reverse cam on the right end of the ribbon-feed shaft. Continued rotation of the shaft causes the cam to push the cam follower downward, pulling the right end of the ribbon-reverse beam downward.

RIBBON-SENSING LEVER PROJECTING THROUGH OPENING IN EMPTY RIBBON SPOOL

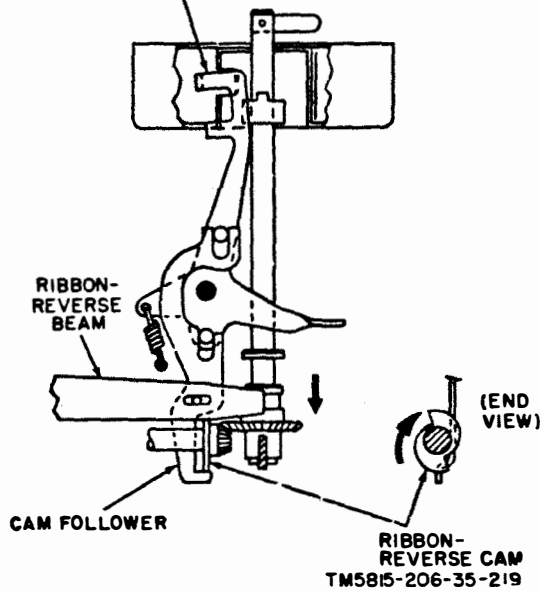

Figure 46. Ribbon-reverse mechanism.

The right spool-shaft gear also moves downward into engagement with its associated gear on the ribbon-feed shaft; the left spool-shaft gear moves upward out of engagement with its associated gear; and the direction of ribbon feed is reversed.

- (3) When the carriage moves to the left margin during the carriage-return operation, the helical gear rotates very rapidly in a direction opposite the normal ribbon-feeding direction. The ribbon-feed shaft remains motionless during the carriage-return operation because the helical gear moves to the right against the pressure of its spring, and the ribbon-feed clutch members are kept out of engagement until the carriage stops at the left margin.

30. Ribbon Lifter Operation

The ribbon moves upward an instant before a type-bar strikes the platen and returns to its normal lower position after the character is printed. The ribbon is threaded through the ribbon guide (fig. 47 and 48) and moves upward and downward with the guide as described below.

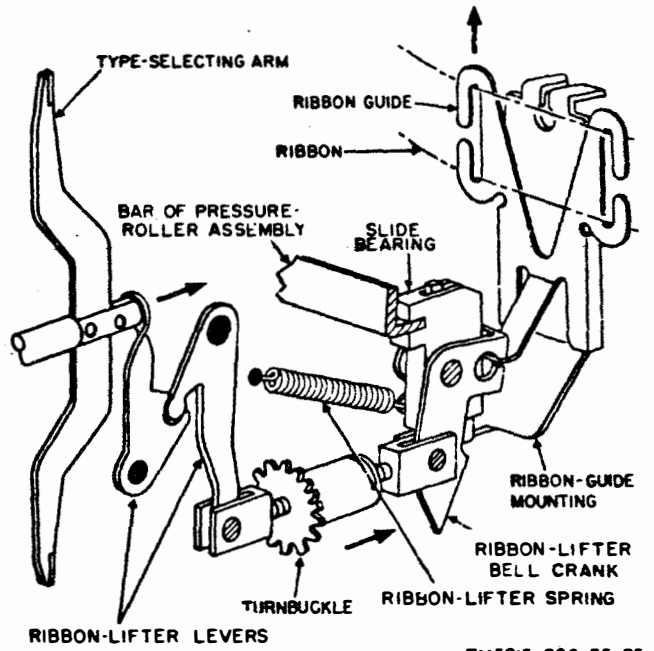

Figure 47. Ribbon lifter mechanism (TT-4B/TG).

a. Each time the type-selecting arm moves forward (par. 22), it causes the ribbon-lifter levers to rotate slightly about their pivot points. When this occurs, the turnbuckle of the TT-4B/TB (fig. 47) or the adjusting links of the TT-4A/TG (fig. 48) move forward, pivoting the ribbon-lifter bell crank, and the ribbon guide and ribbon move upward.

b. When the type-selecting arm moves rearward after the character is printed, the rib-

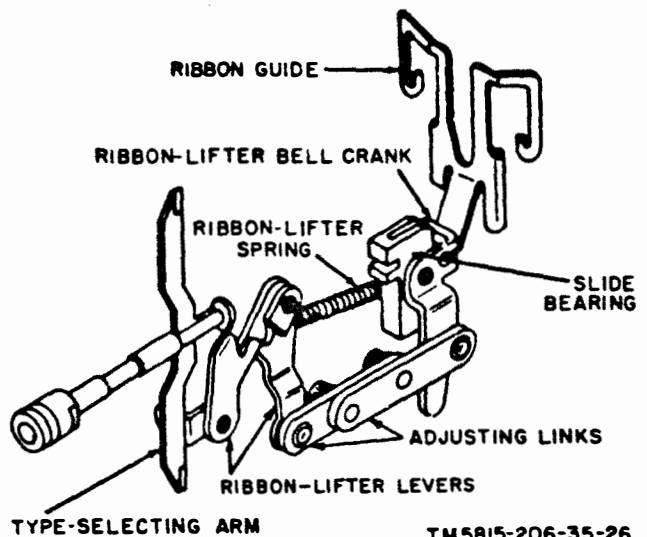

Figure 48. Ribbon lifter mechanism (TT-4A/TG).

bon-lifter spring pivots the ribbon-lifter bell crank downward, causing the ribbon guide to move to the lower position, where it remains until the type-selecting arm moves forward again.

31. Signal-Bell Operation

The signal-bell operation is used by operators for audible signaling. The signal bell sounds when the page printer receives the letter S code group while the platen is in the figures-shift position. Neither printing (par. 22) nor carriage feeding (par. 23) occurs when the signal-bell operation occurs. The signal bell mechanism operates as follows:

a. Selection of Signal-Bell Operation. When the letter S code group is received and the transfer operation occurs, the first and third code rings are set to the marking position and the second, fourth, and fifth code rings are set to the spacing position. The code rings form a groove in line with the S stop bar, which stops rotation of the square-shaft stop arm. When the square-shaft is stopped in this position, the type-selecting arm is in line with the connecting bar which is geared to the S type bar, and the function-selecting arm (fig. 26 and 29) is in line with the signal-bell punch bar in the punch-bar-guide block (fig. 49).

b. Ringing Signal Bell. Immediately after the function-selecting arm is positioned (a above), a lobe of the function cam (fig. 29) causes the function-cam follower to pivot counterclockwise, moving the function-selecting arm against the signal-bell punch bar (fig. 50). The signal-bell punch bar moves inward, pivoting the signal-bell clapper against the signal bell. After the bell rings, the function cam moves the function-selecting arm away from the signal-bell punch bar; the signal-bell-clapper spring pulls the clapper away from the bell and the signal-bell punch bar moves to its normal outward position.

c. Type Selecting Arm Operation. When the function-selecting arm causes the signal bell to be rung (b above), the type-selecting arm moves forward to push the connecting bar for the letter S type bar and the S type bar swings upward toward the platen. Nothing is printed at this time because the upper-case portion of the type bar contains no symbol. The type bar is stopped by the type-bar guide

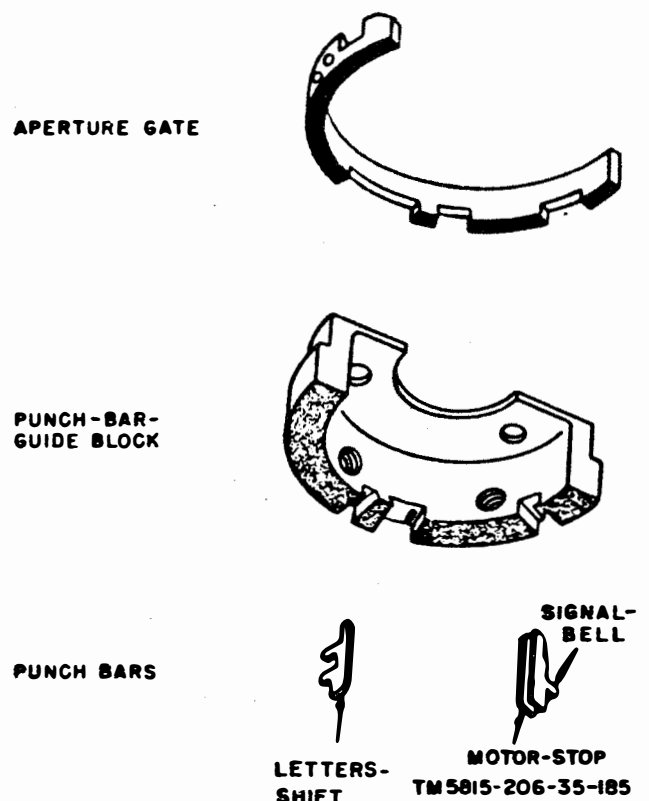

Figure 49. Punch-bar-guide block assembly, exploded view.

before the upper-case part of the type bar reaches the platen.

d. Suppression of the Signal-Bell Operation. When the platen is in the letters-shift position, the aperture gate also is in the letters-shift position (A, fig. 51 and A, 52). When the letter S code group is received under this condition, the type-selecting arm causes the letter S to be printed (par. 22). The function-selecting arm is not permitted to push the signal-bell punch bar inward to ring the signal bell

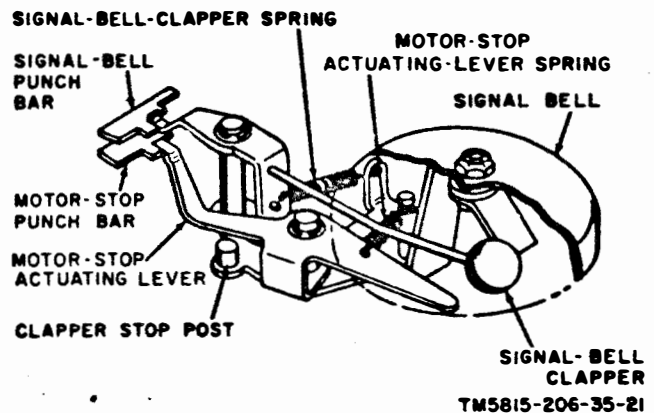

Figure 50. Signal bell mechanism.

because a blocking portion of the aperture gate blocks inward movement of the punch bar. The lobe of the function cam causes the lower end of the function-cam follower to move counter-clockwise, and the carriage-feed operation occurs (par. 23). When the platen is in the

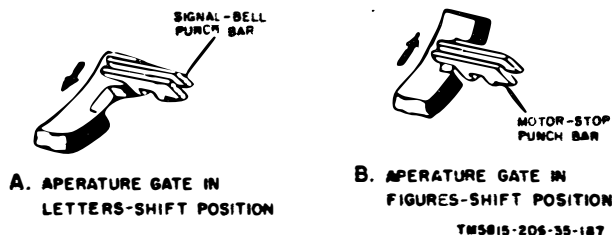

Figure 52. Signal-bell and motor-stop punch bars blocked and not blocked by aperture gates.

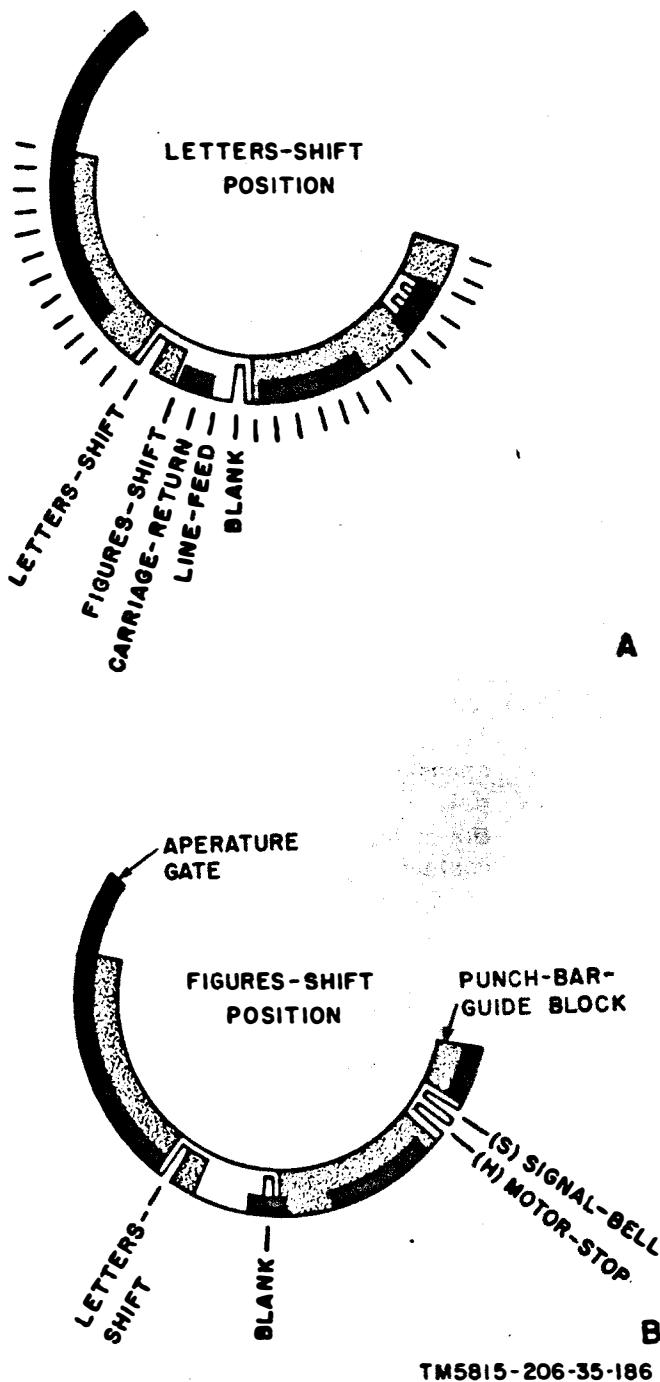

Figure 51. Location of stopped positions of function-selecting arm after receipt of function code groups.

figures-shift position, the aperture gate also is in the figures-shift position (B, fig. 51 and B, 52) of the signal-bell mechanism and the motor-stop mechanism (par. 32).

e. *Sequence of Signal-Bell Operations.* The chart below lists the sequence of operations that occur when the S code group is received while the platen of the page printer is in the figures-shift position.

Signal-bell operation sequence chart

1	Letter S code group received; platen in figures-shift position.	
2	Y-levers positioned for selection of signal-bell operation (par. 19a and b).	
3	Transfer-lever-latching cam trips transfer-lever latch; transfer operation occurs (par. 20).	
4	T-levers and code rings positioned for selection of S stop bar.	Function-clutch latch releases function-clutch drum; function-clutch latch members move into engagement (fig 26).
5	S stop bar moves into groove in code rings.	Function shaft and square shaft start turning.
6	Square-shaft stop arm strikes S stop bar; square shaft stops turning.	
7	Type-selecting arm positioned in alignment with connecting bar geared to letter S type bar.	Function-selecting arm positioned in alignment with signal-bell punch bar in punch-bar-guide block.
8	Lobe of print cam causes type-selecting arm to move forward (fig. 25).	Lobe of function cam pivots function-cam-follower, causing function-selecting arm to push signal-bell punch bar inward (fig. 50).
9	Letter S type bar swings upward; motion of type bar halted before blank portion of type bar strikes platen; nothing printed.	Signal-bell clapper strikes bell.
10	Print cam completes 1/2 revolution; returns type-selecting arm to normal (rearward) position.	Function cam completes 1/2 revolution, returns function-selecting arm to normal (outward) position.

	Transfer-lever restoring cam causes transfer lever to move T-levers upward, away from Y-levers.	Function-clutch latch engages arm of function-clutch drum.
12	Function-clutch drum disengaged from function-shaft driven gear; function shaft stops turning ($\frac{1}{2}$ revolution completed).	

32. Motor-Stop Operation

The motor-stop mechanism permits the operator at any station to start and stop the motor of all teletypewriters that are connected to the same signal circuit. When the letter H code group is transmitted while the platen of each teletypewriter is in the figures-shift position, the motors of all interconnected teletypewriters stop (including the motor of the transmitting teletypewriter). Under this condition, an operator at any of the stations can start all motors by pressing and releasing the BREAK switch on the side of the teletypewriter keyboard. The motor-stop mechanism starts and stops the motor as described below.

a. Selection of Motor-Stop Operation. When the transfer operation occurs after the letter H code group is received, the third and fifth code rings are set to the marking (clockwise) position and the first, second, and fourth code rings are set to the spacing (counterclockwise) position (par. 22). The code rings form a groove in line with the H stop bar. The H stop bar moves into the groove to halt rotation of the square-shaft stop arm. When the stop arm is halted at this point, the type-selecting arm is in line with the connecting bar that is geared to the H type bar, and the function-selecting arm (fig. 26 and 29) is in line with the motor-stop punch bar in the punch-bar-guide block (fig. 49 and 50).

b. Stopping Motor. The motor stops when the motor-stop mechanism opens a pair of contacts that are connected in series with the motor. The contacts are opened as described below.

- (1) Immediately after the function-selecting arm is positioned (*a* above), a lobe of the function cam (fig. 29) causes the function-cam follower to pivot counterclockwise, and move the

function-selecting arm against the motor-stop punch bar (fig. 50). The motor-stop punch bar moves inward (platen in figures-shift position), pivoting the motor-stop actuating lever. One end of the actuating lever pushes the top of the contact lever away from the motor-stop relay (fig. 53 and 55).

- (2) The contact lever includes two operating arms that move with the contact lever. When the contact lever is pushed by the actuating lever, the following action occurs:

- (a) The operating arms of the TT-4B/TG (fig. 53 and 54) push the plungers of switches S5 and S6, and cause the circuit through each switch to open. Switch S6 is in series with the motor (fig. 59) and the motor stops. Switch S5 opens to remove a short circuit across the motor-stop relay, and the signal circuit current flows through the relay. The energized relay pulls the relay armature downward (A, fig. 54) to lock the contact lever in the operated position (away from the relay) until the motor start operation occurs (*c* below).
- (b) The operating arms on the contact lever of the TT-4A/TG (fig. 55) opens two pairs of contacts. One pair is in series with the motor and the motor stops. The other pair of contacts opens to remove a short

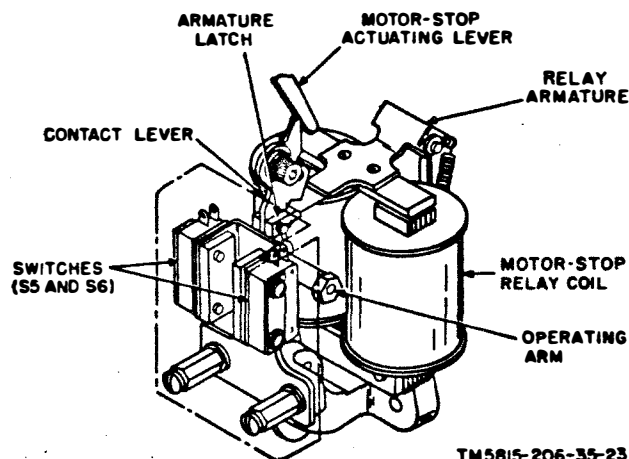

Figure 53. Motor-stop relay mechanism (TT-4B/TG).

against the fig. 50). The no (inward position), pivoting lever. g lever pushes er away from g. 53 and 55). les two oper- with the con- tact lever is lever, the fol-

of the TT- 54) push the S5 and S6, through each h S6 is in se- (fig. 59) and tch S5 opens uit across the the signal cir- rough the re- lay pulls the ward (A, fig. t lever in the ay from the s (opera-

n the contact TG (fig. 55) contacts. One he motor and other pair of move a short

OP LEVER
RELAY ARMATURE
MOTOR-STOP RELAY COIL
OPERATING ARM

TM5815-206-35-23
(TT-4B/TG).

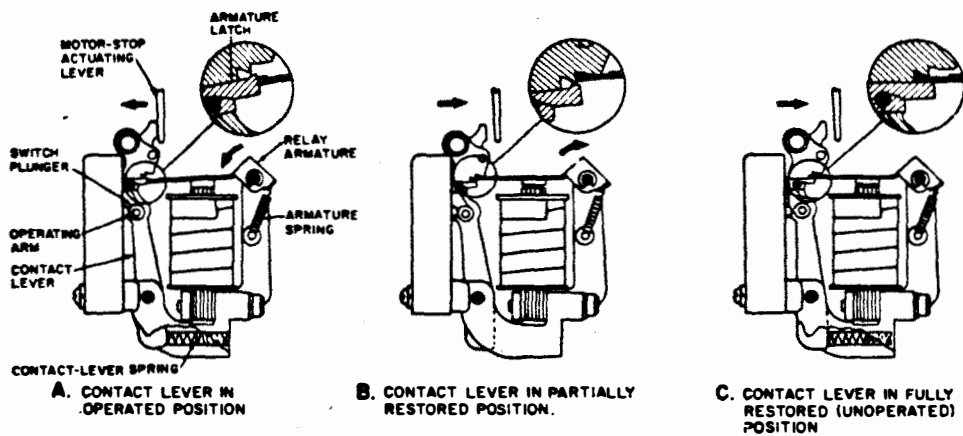

Figure 54. Positions of TT-4B/TG contact lever.

circuit around the motor-stop relay (fig. 58), and the signal circuit flows through the coils of the relay. The magnetic field produced by the current in the signal circuit pulls the relay armature downward, and the contact lever is latched in the operated position by the armature (A, fig. 56).

c. Starting Motor. Depression of the BREAK switch at any of the interconnected teletype-writers opens the signal circuit (fig. 58 and 59)

and the motor-stop relay of each page printer is de-energized. The armature spring (fig. 54 and 56) pivots the armature upward and the contact lever moves *slightly* toward the restored position (position before motor-stop operation) (B, fig. 54 and 56). When the BREAK switch is released, the motor-stop relay is energized again. The armature moves downward and the contact lever moves to the fully restored position (C, fig. 54).

(1) The plungers of the TT-4B/TG switches S5 and S6 move to their normal (outward) position. Switch S6 (fig. 58) closes to complete the motor circuit, and the motor begins operating. Switch S5 closes to place a short circuit across the motor-stop relay and the signal circuit is completed through S5 instead of through the coils of the relay.

(2) The two pairs of contacts of the TT-4A/TG move to their normal (closed) position. One pair of contacts completes the motor circuit (fig. 59), and the motor begins operating. The other pair closes to place a short circuit across the motor-stop relay, and the signal circuit is completed through the contacts.

d. Suppression of Motor-Stop Operation. When the platen of the page printer is in the letters-shift position, the aperture gate (A, fig. 51 and A, fig. 52) is in the letters-shift position also. When the letter H code group is received under this condition, the type-selecting

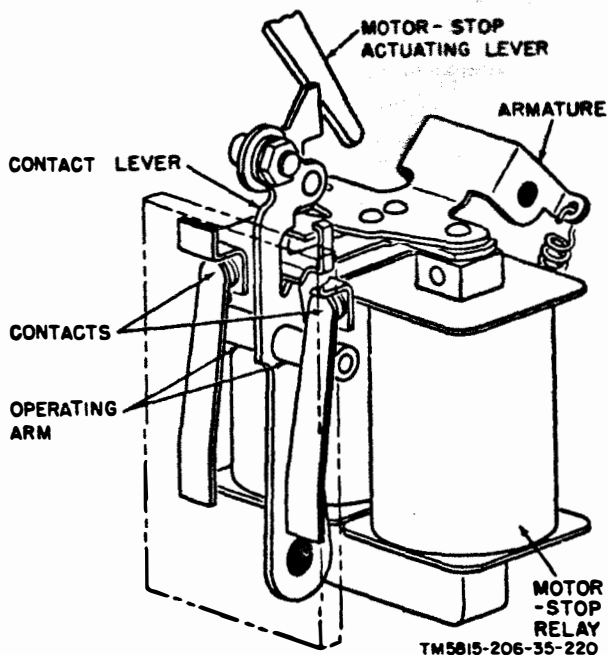
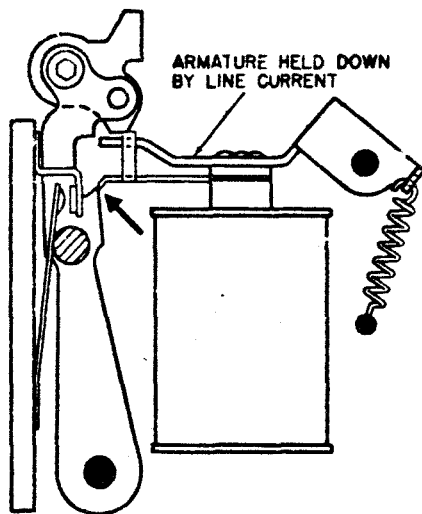
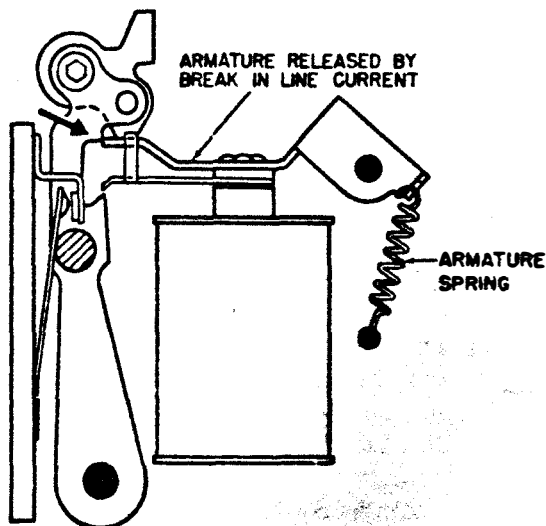

Figure 55. Motor-stop relay mechanism (TT-4A/TG).



A. CONTACT LEVER HELD IN CONTACT-OPEN POSITION BY ARMATURE AFTER MOTOR-STOP OPERATION.



B. CONTACT LEVER PARTIALLY RESTORED BY BREAK SIGNAL.

TM5815-206-35-221

Figure 56. Positions of TT-4A/TG contact lever.

arm causes the letter H to be printed (par. 22). The function-selecting arm is not permitted to push the motor-stop punch bar inward to stop the motor, because a blocking portion of the aperture gate blocks inward movement of the punch bar. The lobe of the function cam causes the lower end of the function-cam follower to move counterclockwise, and carriage feeding occurs (par. 23).

e. Sequence of Motor-Stop Operations. The chart below lists the sequence of operations that occur when the letter H code group is received while the platen of the page printer is in the figures-shift position.

Motor-stop operation sequence chart

- | | | |
|---|--|--|
| 1 | Letter H code group received while platen is in figures-shift position. | |
| 2 | Y-levers positioned for selection of motor-stop operation (par. 19a and b). | |
| 3 | Transfer-lever-latch tripping cam trips transfer-lever latch; transfer operation occurs (par. 20). | |
| 4 | T-levers and code rings positioned for selection of H stop bar. | Function-clutch latch releases function-clutch drum; function-clutch members move into engagement (fig. 26). |
| 5 | H stop bar moves into groove formed in code rings. | Function shaft and square shaft start turning. |
| 6 | Square-shaft stop arm strikes stop bar; square shaft stops turning. | |
| 7 | Type-selecting arm positioned in line with connecting bar geared to letter H type bar. | Function-selecting arm positioned in line with motor-stop punch bar in punch-bar-guide block. |
| 8 | Lobe of print cam causes type-selecting arm to move forward (fig. 25). | Lobe of function cam pivots function-cam follower, causing function-selecting arm to push motor-stop punch bar inward (fig. 29 and 49). |
| 9 | Letter H type bar swings upward; motion of type bar halted before blank portion of type bar strikes platen; nothing printed. | Motor-stop punch bar pivots motor-stop actuating lever (fig. 50); actuating lever moves contact lever to operated position (A, fig. 54 and 55); motor circuit opened to stop motor; short circuit across motor-stop relay removed to energize relay; energized relay holds contact lever in operated position. |
| 10 | Print cam completes $\frac{1}{2}$ revolution; returns type-selecting arm to normal (rearward position). | Function cam completes $\frac{1}{2}$ revolution, returns function-selecting arm to normal (outward) position. |
| 11 | Transfer-lever restoring cam causes transfer lever to move T-levers upward, away from Y-levers. | Function-clutch latch engages arm of function-clutch drum (par. 26). |
| 12 | Function-clutch drum disengaged from function-shaft driven gear; function shaft stops turning ($\frac{1}{2}$ revolution completed). | |
| <p><i>Note.</i> When the operator at any of the interconnected teletypewriters presses and releases the BREAK switch, the following occurs:</p> | | |
| 13 | BREAK switch pressed; signal circuit and motor-stop relay de-energized; armature moved upward from motor-stop relay. | |
| 14 | Contact lever moved slightly toward restored position (B, fig. 54 and 56). | |

Motor-stop operation sequence chart — Continued

- 15 BREAK switch released; signal circuit and motor-stop relay energized; armature moves downward toward motor-stop relay.
- 16 Contact lever moved to fully restored position; motor circuit completed to start motor; short circuit placed across motor-stop relay to deenergize relay.

33. Teletypewriter Timing Chart

The timing chart (fig. 57) shows the precise sequence of the major operations of the teletypewriter. Supplementary information is provided in *a* through *c* below.

a. Overlap. Overlap permits the receipt of a new code group and the positioning of the Y-levers for a new selection while the printing or function operation selected by the preceding code group is being accomplished. Overlap is possible because the Y-levers are lifted upward, away from the Y-levers, immediately after the code-rings are positioned. The Y-levers are then free to be repositioned in accordance with the code impulses of the next code group without interference with the accomplishment of the preceding selection.

b. Carriage-Return Time Requirement. The

time required for completion of the carriage-return operation exceeds 2½ times the time length of a complete code group. If a character-selecting code group is received immediately after the carriage-return code group, the character is printed while the carriage is returning to the left margin. For this reason, when the end of a line of printing is reached, operators normally press the CAR RET key first, and then the LINE FEED key. Under this condition, the end of the carriage-return operation and the complete line-feed operation occur simultaneously, and both operations are completed before the next character is printed.

c. Transmitted Code Impulses and Page Printer Selecting Intervals. The time intervals between the high points of the code impulse cams in the keyboard-transmitter and the selector cams in the page printer are equal. However, the selector levers of the transmitter are held in the operated position by the code impulse cams for the full length of the impulse, but the selector levers of the page printer require less than ¼ the length of each code impulse to position the associated Y-lever. This feature permits reliable teletypewriter communication with less than perfect impulses.

Section IV. CIRCUITS OF TELETYPEWRITERS TT-4A/TG AND TT-4B/TG

34. General

The circuits of the TT-4(*)/TG include the send circuit (par. 35), the receive circuit (par. 36), and the motor and copy light circuits (par. 37). These circuits are shown in schematic form in figures 58 and 59 and the actual wiring is illustrated in figures 60 and 61. Note that reference designations of some of the parts in the TT-4A/TG differ from the designations of the same parts in the TT-4B/TG. The chart below shows the reference designations of the electrical parts that are not assigned the same designation in both teletypewriters.

35. Send Circuit

(fig. 58-61)

The send circuit (*a* below) is used to transmit intelligence in the form of groups of coded electrical impulses. The send circuit of the TT-4B/TG is shorted (*b* below) when the motor-stop operation occurs (par. 32).

a. The send circuit can be traced from line

Part	Designations for	
	TT-4B/TG	TT-4A/TG
Copy light	E1	DS1
Motor-stop contact assembly.	50969A	Not included
Motor-stop relay	E3	L1
Motor-stop-relay switch (relay-coil shorting).	Not included	S5
Motor-stop-relay switch (motor circuit).	Not included	S6
Power input filter	Z1	FL1
Selector magnet	E2	E1
Transmitter filter	Z2	FL2

terminal 1 through the shorting bar (between line terminals 5 and 6), connectors J2 and P2, BREAK switch S3, transmitter filter Z2 (TT-4A/TG) or FL2 (TT-4B/TG), contact bail E4, the mark contact of TR1, the transmitter filter, connectors P2 and J2 to line terminal 2. The contact bail is moved mechanically away from

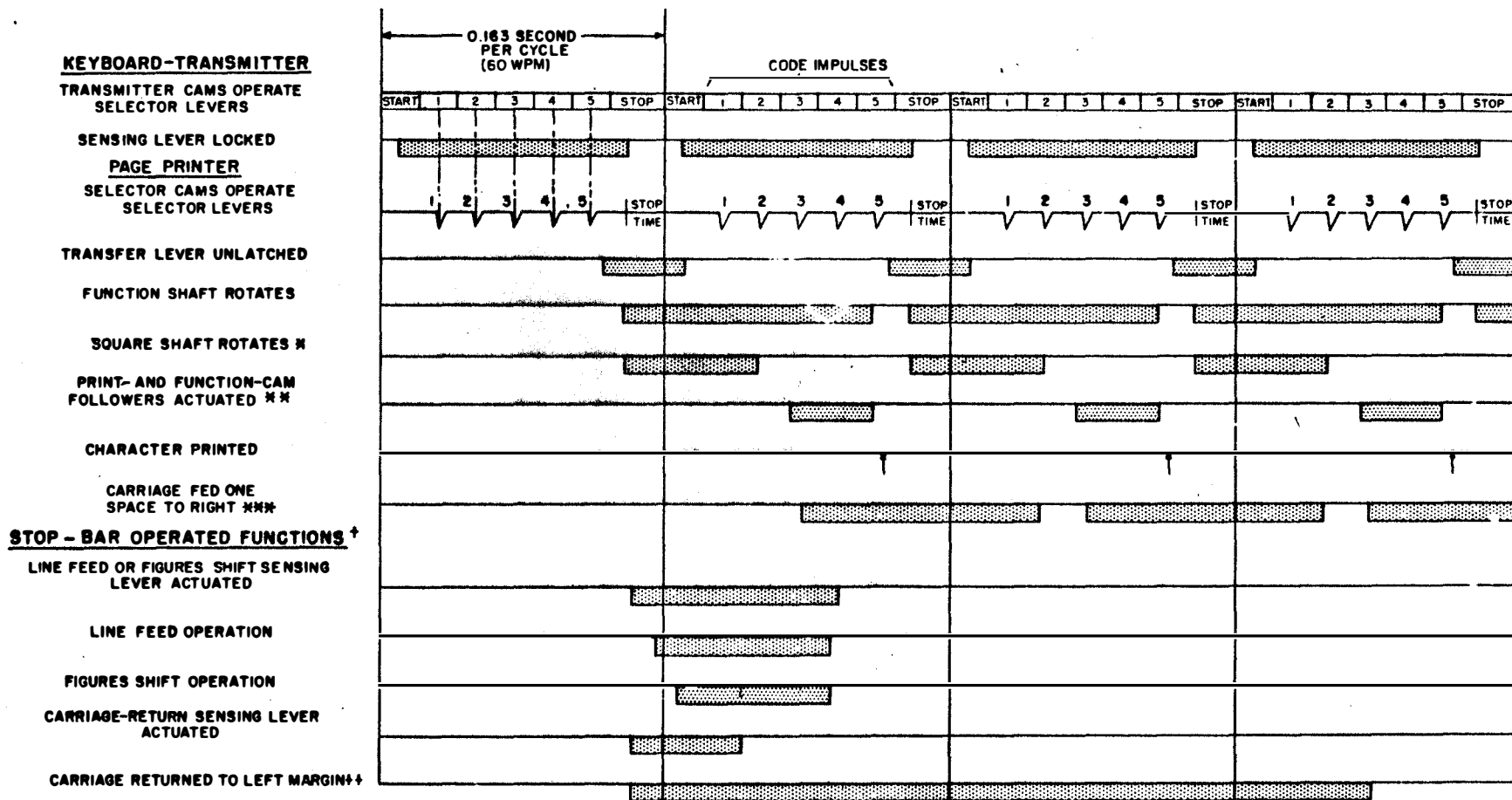

- * TIME SHOWN IS MAXIMUM POSSIBLE, BUT CAN BE ANY AMOUNT (EVEN ZERO) DEPENDING ON SEQUENCE OF CHARACTERS.
- ** EITHER PRINTING OR ONE OF FOLLOWING FUNCTIONS OCCUR, UNLESS STOP-BAR OPERATED FUNCTION IS SELECTED: LETTERS-SHIFT SPACE, SIGNAL BELL, MOTOR STOP, BLANK.
- *** ONLY FOR PRINTED CHARACTERS AND SPACING.
- † ONLY ONE FUNCTION STARTS IN ANY CYCLE; THREE FUNCTIONS ARE SHOWN FOR COMPARISON.
- †† TIME SHOWN IS FOR RETURN FROM 72ND SPACE.

Figure 57. Teletypewriter timing chart.

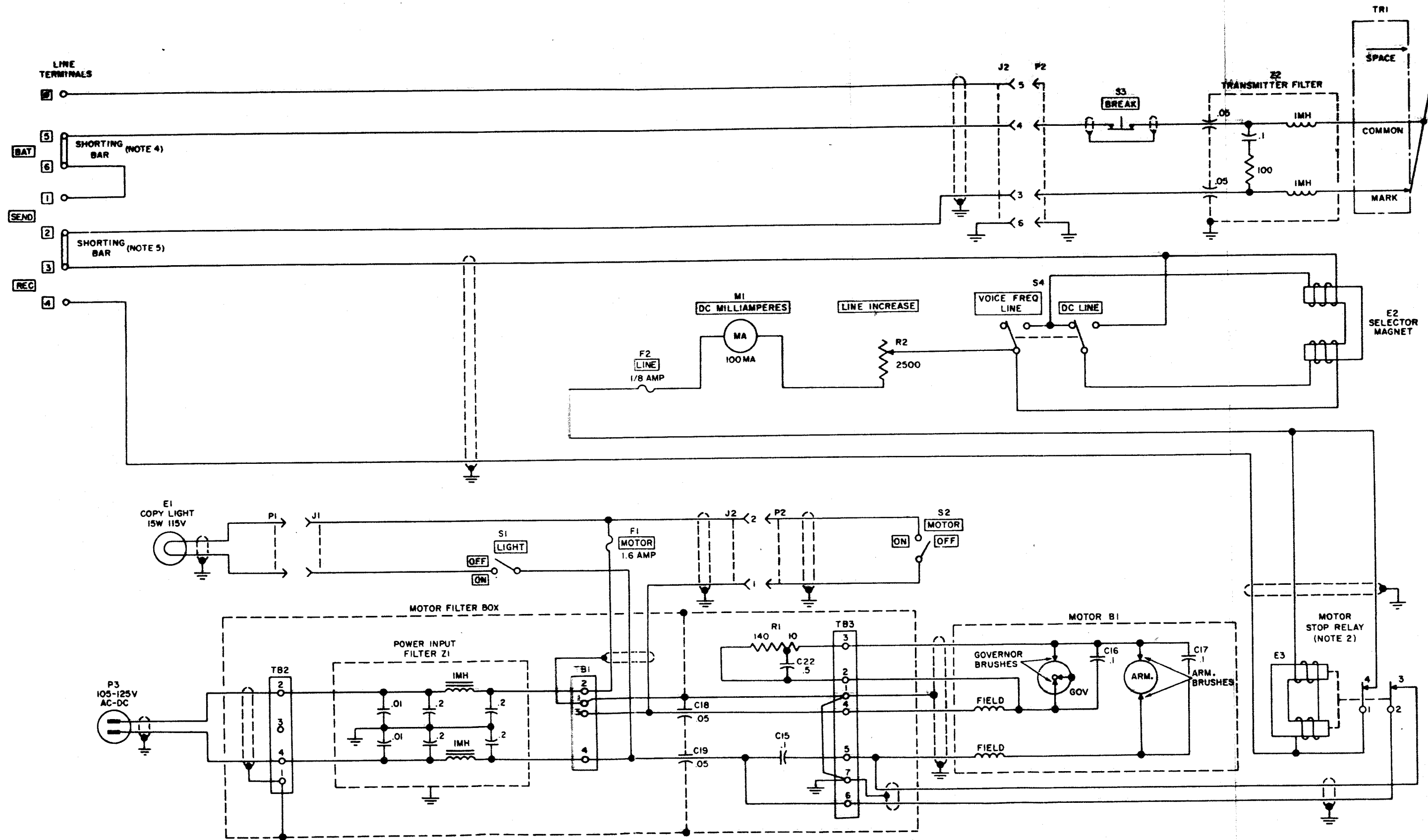

- NOTES:**
1. UNLESS OTHERWISE INDICATED RESISTORS ARE IN OHMS; CAPACITORS ARE IN UF.
 2. MOTOR STOP RELAY CONTACTS LATCH MECHANICALLY IN CLOSED POSITION AND OPEN BY OPERATION OF MOTOR-STOP MECHANISM. ONCE OPEN, CONTACTS REMAIN SO, AS LONG AS RELAY IS ENERGIZED. CONTACTS CLOSE AND LATCH AGAIN UPON BREAK AND MAKE OF LINE CURRENT.
 3. END VIEW OF PLUGS AND JACKS.

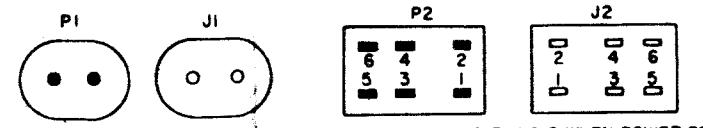

4. SHORTING BAR CONNECTED ACROSS LINE TERMINALS 5 AND 6 WHEN POWER FOR SIGNAL CIRCUIT IS NOT SUPPLIED LOCALLY. DISCONNECT SHORTING BAR WHEN USING LOCAL POWER SOURCE.
5. SHORTING BAR CONNECTED ACROSS LINE TERMINALS 2 AND 3 FOR HALF-DUPLEX OPERATION. DISCONNECT SHORTING BAR WHEN INSTALLING FOR FULL-DUPLEX OPERATION.

Figure 58. Teletypewriter TT-4A/TG, schematic diagram.

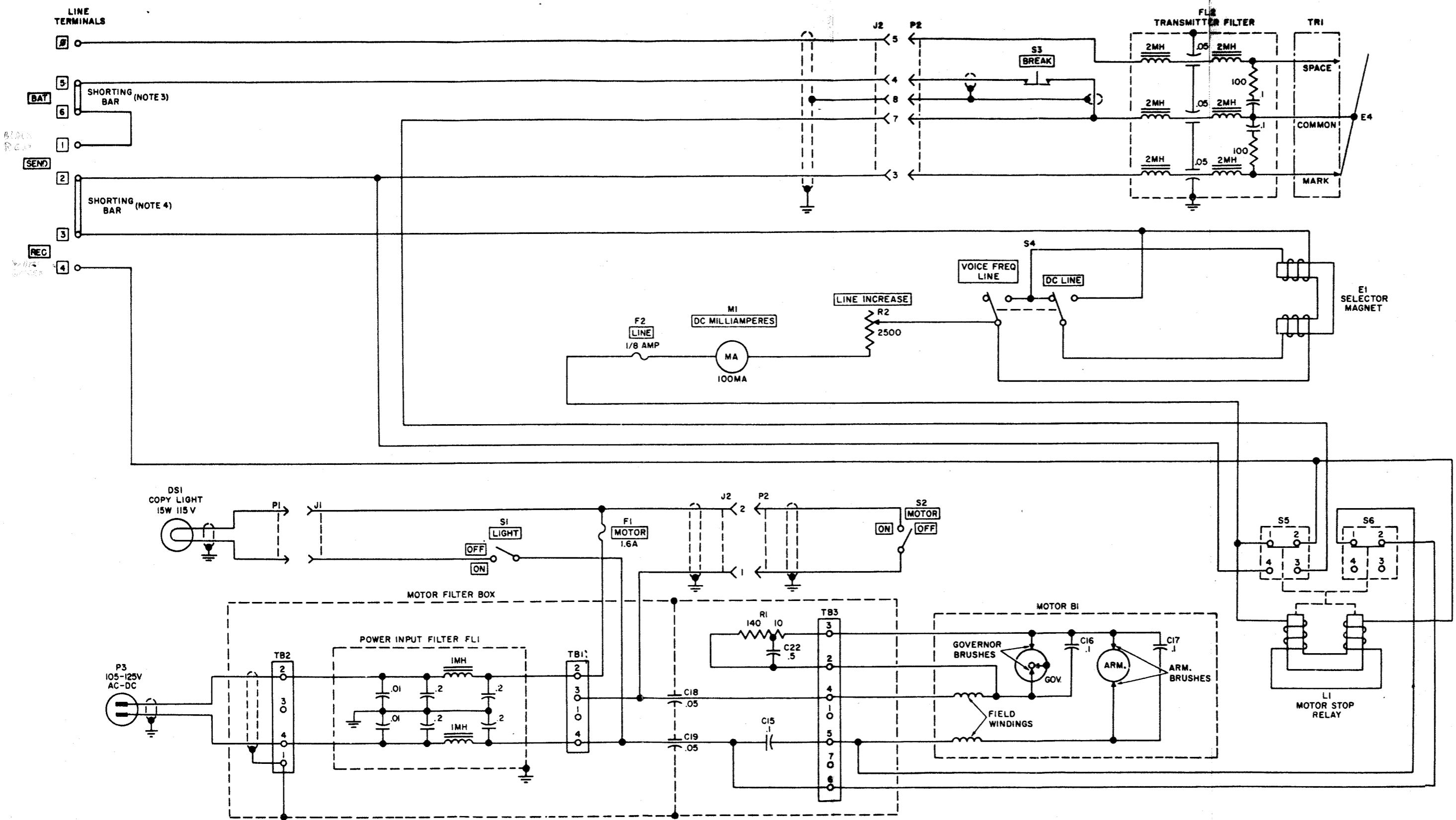

- NOTES:
- UNLESS OTHERWISE INDICATED RESISTORS ARE IN OHMS; CAPACITORS ARE IN UF.
 - END VIEW OF PLUGS AND JACKS.

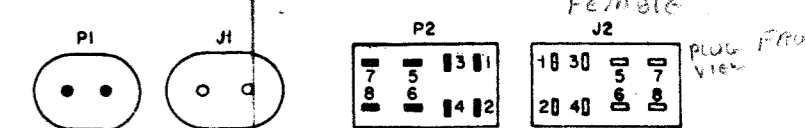

- SHORTING BAR CONNECTED ACROSS LINE TERMINALS 5 AND 6 WHEN POWER FOR SIGNAL CIRCUIT IS NOT SUPPLIED LOCALLY. DISCONNECT SHORTING BAR WHEN USING LOCAL POWER SOURCE.
- SHORTING BAR CONNECTED ACROSS LINE TERMINALS 2 AND 3 FOR HALF-DUPLEX OPERATION. DISCONNECT SHORTING BAR WHEN INSTALLING FOR FULL-DUPLEX OPERATION.

CONNECTOR 7 Red
 5 Yellow
 3 Brown
 1 Green
 2 Black
 4 Orange

Figure 59. Teletypewriter TT-4B/TG, schematic diagram.

the mark contact to open the signal circuit for transmission of a spacing impulse, and is moved against the marking contact for transmission of a marking impulse (par. 10 and 11). BREAK switch S3 is used to open and close the signal circuit manually to start the motors of interconnected teletypewriters after they have been placed in the stopped condition as a result of the motor-stop operation (par. 32). If power for the signal circuit is supplied locally, the shorting bar between line terminals 5 and 6 is disconnected and 105- to 125-volt dc power is connected to these terminals (positive polarity to terminal 6).

b. The TT-4B/TG (fig. 59) includes a motor-stop-relay switch (S5) that places a short circuit across the mark contact and contact bail E4 when the motor-stop operation occurs (par. 32). The inclusion of the shorting circuit insures that if the motor should stop when the contact bail is against the *space* contact, the signal circuit (and motor-stop relay) will remain energized and the motor can be started again by operation of the BREAK switch.

36. Receive Circuit

(fig. 58-61)

The receive circuit is used to permit electrical control of the page printer mechanisms. The receive circuit normally is connected in series with the send circuit (shorting bar across line terminals 2 and 3), and a copy of each transmitted message is printed by the page printer of the sending teletypewriter. The receive circuit of the TT-4(*)/TG is capable of operating with *neutral* teletypewriter impulses only (par. 4). The signal current level in the receive circuit may be either 60 ma (LINE switch in DC LINE position) or 20- to 30-ma (LINE switch in VOICE FREQ LINE position).

a. *Receive Circuit During Message Reception.* The receive circuit can be traced from line terminal 3 through LINE switch S4 and the coils of the selector magnet. When S4 is in the VOICE FREQ LINE position, the two coils of the selector magnet are in series with each other and in series with the receive circuit. When S4 is in the DC LINE position, the coils are connected in parallel with each other. The circuit continues through LINE INCREASE

variable resistor R2, DC MILLIAMPERES meter M1, LINE fuse F2, switch S5 (TT-4B/TG) or motor-stop-relay contacts (TT-4A/TG), and is completed at line terminal 4.

b. *Receive Circuit After Motor Stop Operation.* After the motor-stop operation is completed (par. 32), the receive circuit is as described in *a* above with the following exceptions:

- (1) The circuit through terminals 1 and 2 of switch S5 (TT-4B/TG) or the motor-stop-relay contacts (TT-4A/TG) is open.
- (2) The two coils of the motor-stop relay are connected in series with the receive circuit.

37. Motor and Copy Light Circuits

(fig. 58-61)

The motor and copy light circuits require 105- to 125-volts either dc or ac (50- to 60-cps). Power for both circuits is supplied through plug P3.

a. *Motor Circuit.* The motor circuit can be traced from a blade of plug P3 through power input filter Z1 (TT-4A/TG) or FL1 (TT-4B/TG), motor fuse F1, MOTOR switch, S2, feedthrough capacitor C18, one of the field windings of the motor, to one of the governor brushes. When the governor contacts are closed during operation of the governor (par. 7), the circuit continues through the governor contacts and the other governor brush to one of the armature brushes. When the governor contacts open, the circuit continues through resistor R1 to the armature brush. The circuit continues through the armature, the other armature brush, the other field winding of the motor, through either switch S6 (TT-4B/TG) or a pair of contacts of the TT-4A/TG motor-stop relay, and is completed through feedthrough capacitor C19 and the power input filter to the other blade of plug P3.

- (1) When the motor-stop operation occurs (par. 32), switch S6 of the TT-4B/TG or the contacts of the TT-4A/TG motor-stop relay open to stop the motor. Operation of the BREAK key on the teletypewriter keyboard causes the motor circuit to be completed through S6 or the motor-stop relay contacts and the motor starts.

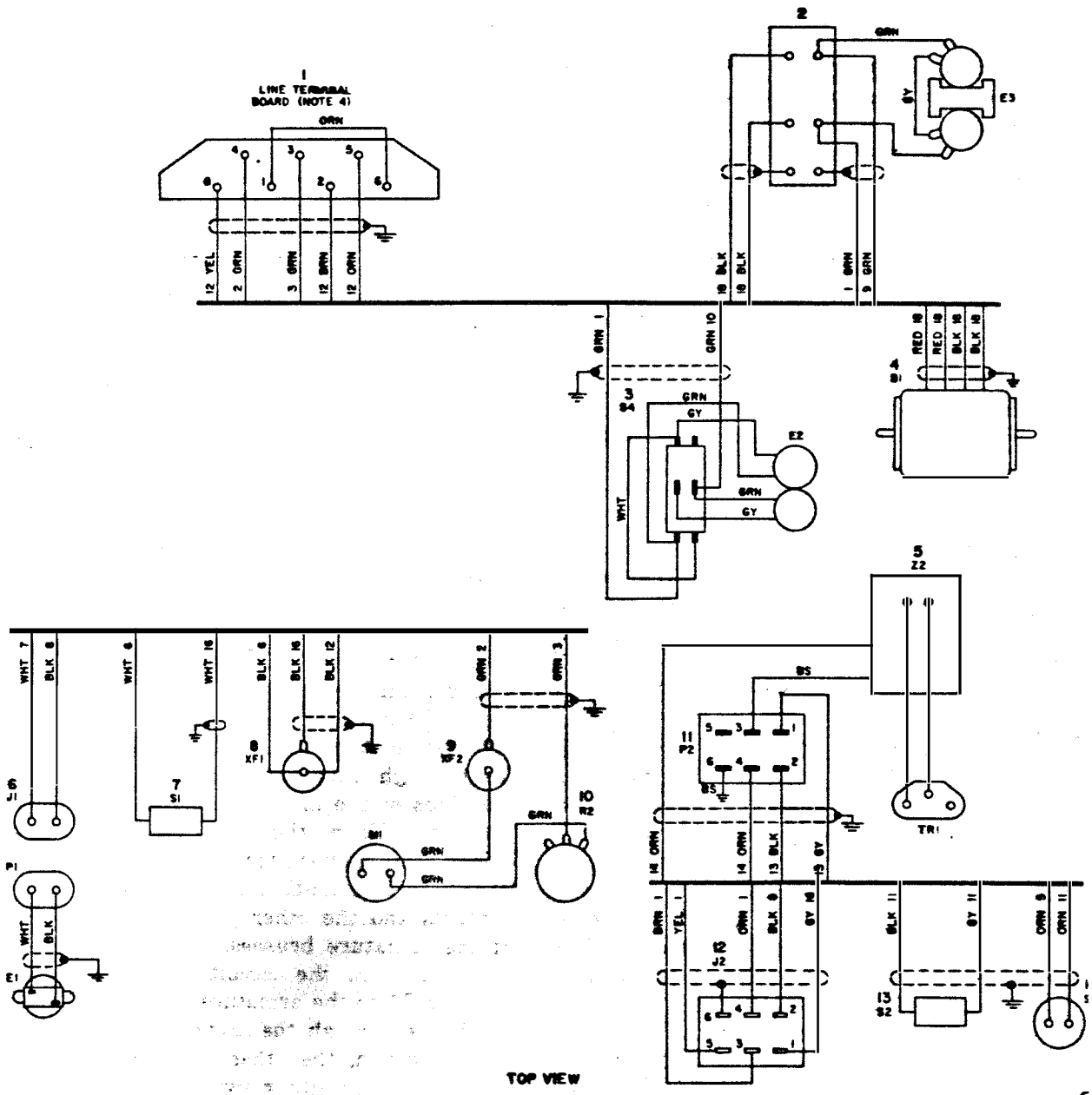

TM585-206-35-30

Figure 60. Teletypewriter TT-4A/TG, wiring diagram.

(2) Capacitors C15, C16, C17, and C22, and the power input filter suppress radio-frequency interference.
 b. Copy Light Circuit. The copy light circuit

is traced from one blade of plug P3, through the power input filter, MOTOR fuse F1, coil, LIGHT switch S1, through the power input filter to the other blade of plug P3.

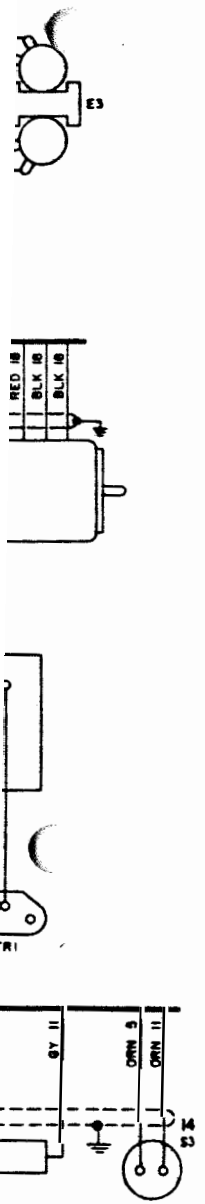

TM 5815-206-35-30 ①

plug P3, through
R fuse F1, copy
ough the power
plug P3.

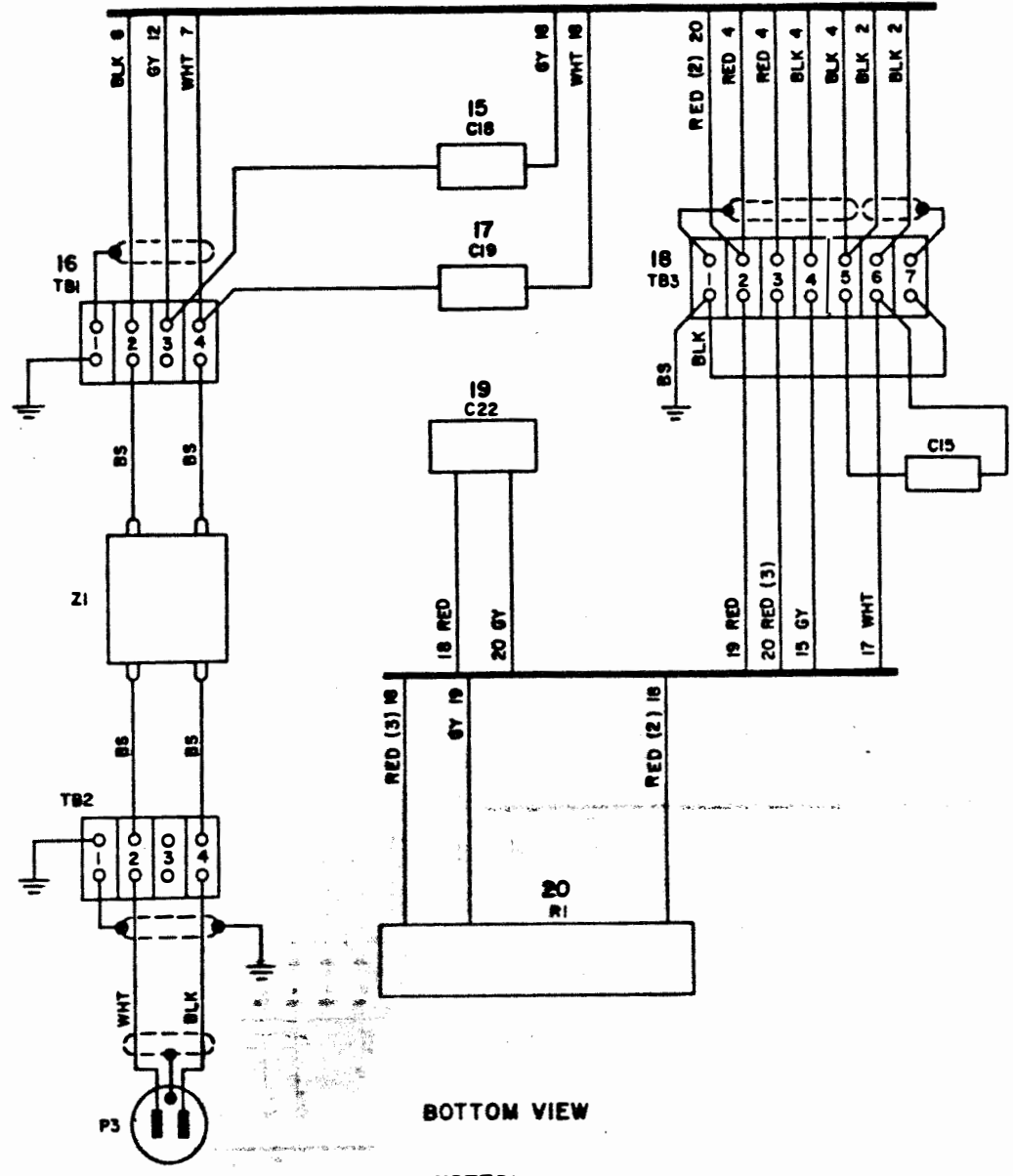

BOTTOM VIEW

NOTES:

1. THE SMALL NUMBER ON EACH WIRE (ADJACENT TO THE COMMON OR BASE LINE) CORRESPONDS TO THE LARGE NUMBER ADJACENT TO THE STATION TO WHICH THE WIRE RUNS.
2. BS DENOTES BARE TINNED COPPER STRAP.
3.  DENOTES SHIELDED CONNECTION.
4. LINE TERMINAL BOARD IS USED FOR THE SIGNAL LINE AND LINE CURRENT CONNECTIONS.

TM 5815-206-35-30 ②

Figure 60.—Continued.

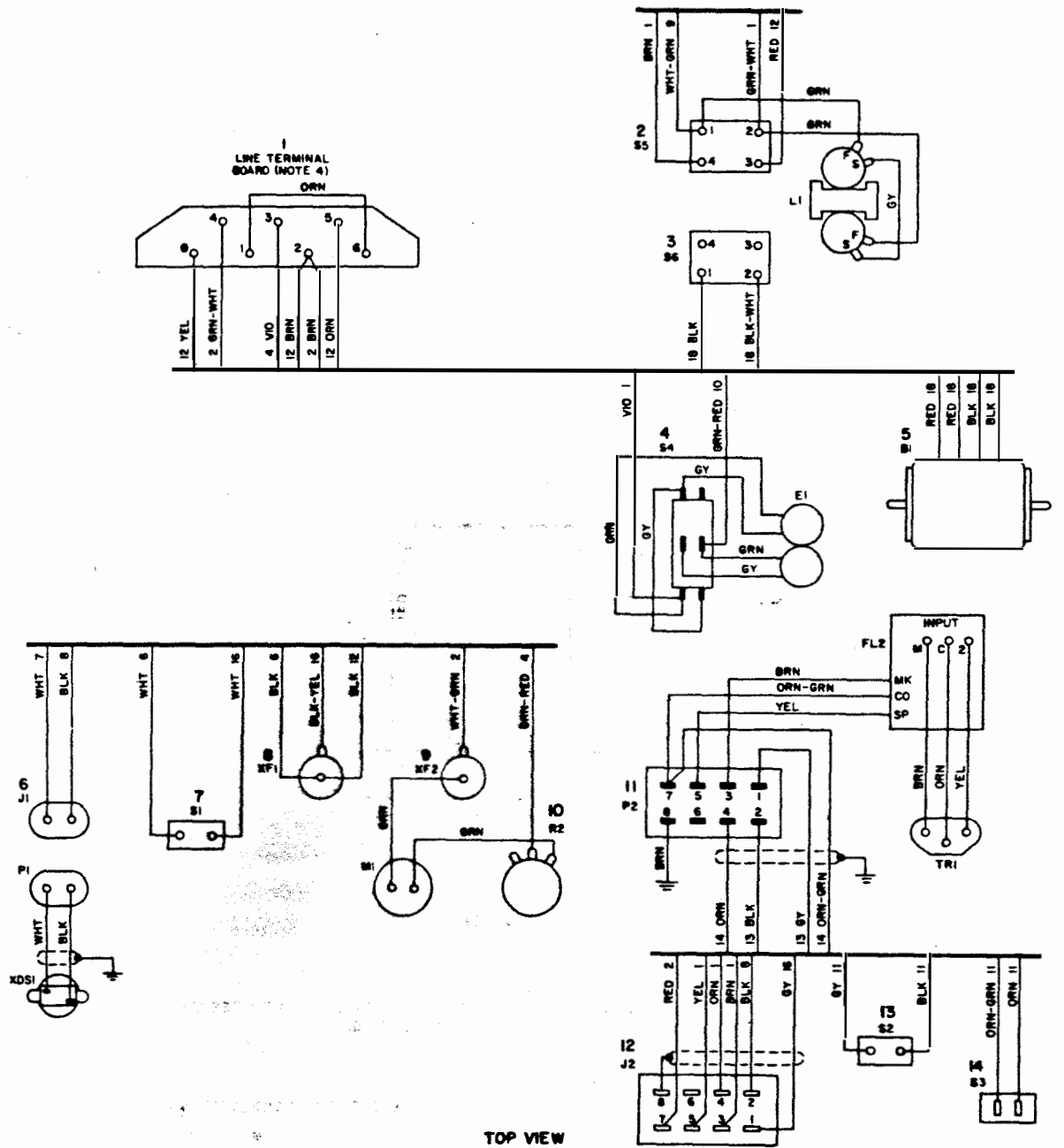
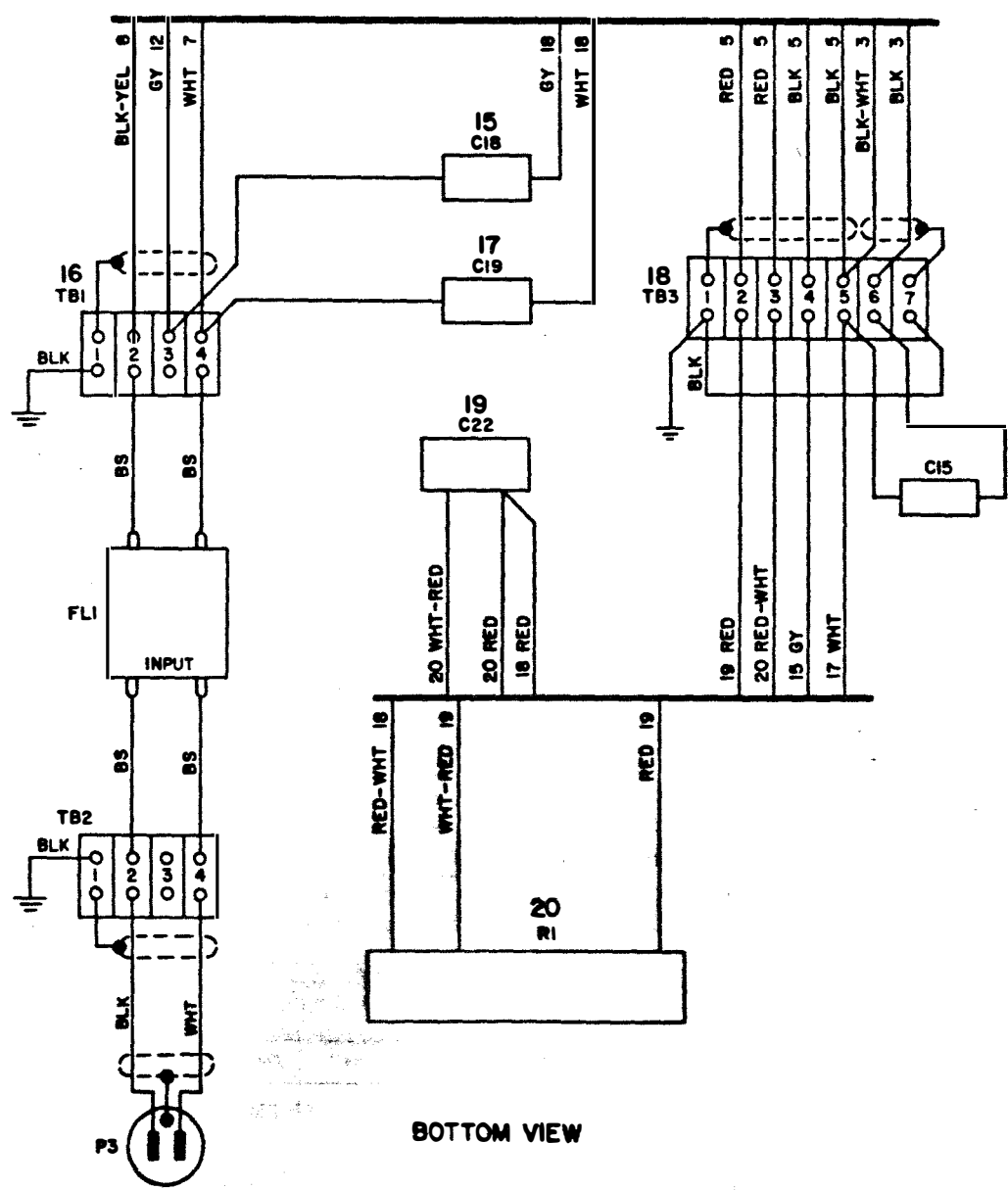
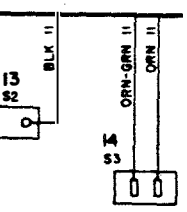
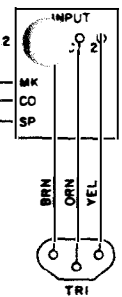
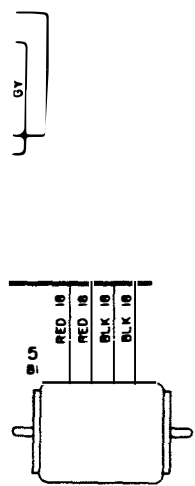

Figure 61. Teletypewriter TT-4B/TG, wiring diagram.

TM587-206-35-31 ①



BOTTOM VIEW

NOTES:

1. THE SMALL NUMBER ON EACH WIRE (ADJACENT TO THE COMMON OR BASE LINE) CORRESPONDS TO THE LARGE NUMBER ADJACENT TO THE STATION TO WHICH THE WIRE RUNS.
2. BS DENOTES BARE TINNED COPPER STRAP.
3. DENOTES SHIELDED CONNECTION.
4. LINE TERMINAL BOARD IS USED FOR THE SIGNAL LINE AND LINE CURRENT CONNECTIONS.

Figure 61.—Continued.

TM 5815-206-35-31 (2)

TM 5815-206-35-31 (1)

CHAPTER 3

MAINTENANCE INSTRUCTIONS

Section I. GENERAL

38. Scope

This chapter includes instructions for third, fourth, and fifth echelons (field and depot) maintenance of Teletypewriter Set AN/PGC-1 and Teletypewriter TT-4(*)/TG. Refer to TM 11-5815-206-12 for supplementary information that is required for these echelons of maintenance.

39. Tools and Shop Equipment

Most of the tools required for maintenance of the teletypewriter set are included in Tool Equipments TE-50-B and TE-111. The additional tools required are standard shop equipment for organizations authorized to perform field and depot maintenance. Shop equipment required for field and depot maintenance of the teletypewriter set includes metal-working tools, numbered and fractional-size drill sets, National Coarse (NC) and National Fine (NF) tap and die sets, 1/4-inch electric hand drill, bearing puller, and an arbor press.

40. Maintenance Materials

The maintenance materials required are listed below.

Item	Stock No.
Orange stick ^a	5120-408-4036 (Fed)
Brush, toothbrush style ^a	53-B-121610 (QMC)
Cheesecloth, bleached ^a 36 inches wide.	27-C-11656-36 (QMC)
Cloth, abrasive, #9 ^a 9- x 11-inch sheets.	42-C-20363-50 (Ord C)
Cleaning Compound, liquid form.	7930-395-9542 (Fed)
Paper, cleaning, bell seal ^a bond, 1/4- x 2 1/2-inch.	7530-408-0256 (Fed)
Sandpaper, flint, #000 ^a 9- x 10-inch.	42-P-1154-20 (Ord C)

Item	Stock No.
Dry cleaning solvent (SD) Compound, antiseize	6850-264-9039 (QMC)
Brush, oval, No. 2 ^a	52-2724.5000.080 (CE)
Tape TL-636/U ^a	38-4567.300.200 (CE)
Tape TL-83 ^a	5970-296-1175 (Fed)
Grease (KS7471)	5970-184-2003 (Fed)
Oil (KS 7470)	6G650 (Sig C)
Moistureproofing and Fungiproofing Kit MK-2/GSM.	6G1325 (Sig C)
	6Z6609-2 (Sig C)

^a Part of Tool Equipment TE-50-B.

41. Test Equipment

The following chart lists the test equipment required for maintenance of the AN/PGC-1 and TT-4(*)/TG.

Test equipment	Technical manual	Use
Multimeter TS-297/U ^a .	TM 11-5500	Used to measure voltage, current, and resistance.
Ohmmeter ZM-21/U.	TM 11-2050A	Used to make insulation breakdown tests.
Test Set TS-2/TG (third echelon).	TM 11-2208	Used to check bias and end distortion tolerance of page printer.
Distortion Test Set TS-383/GG (fourth and fifth echelons only).	TM 11-2217	Used to check bias and end distortion tolerance of page printer and quality of signals originated by keyboard-transmitter.

^a Part of TE-50-B.

Section II. PREVENTIVE MAINTENANCE

42. Use of Preventive Maintenance Form

a. Use DA Form 11-252, Maintenance Check List for Signal Equipment (Teletypewriter) (fig. 62 and 63) as directed by the local commander, while performing preventive maintenance on Teletypewriter Set AN/PGC-1 and Teletypewriter TT-4(*)/TG.

b. Items not applicable to Teletypewriter Set AN/PGC-1 and Teletypewriter TT-4(*)/TG are lined out in figures 62 and 63. Reference in the ITEM block on the form are to paragraphs in this manual which contain additional maintenance information pertinent to the particular item.

c. Although this form lists the readily accessible parts and surfaces that require regular inspections for dirt, maladjustments, and signs of wear, it does not list all the less accessible parts of the teletypewriter that also require preventive maintenance care. When preventive maintenance routines are performed, check all parts for dirt, rust, corrosion, fungus, and ordinary signs of wear, whether or not these parts are listed on the form.

43. General Cleaning Instructions

Detailed instructions that pertain to specific areas of maintenance, such as lubrication, disassembly and reassembly, and adjustment, are provided in other parts of this chapter. The following *general* cleaning instructions supplement the detailed maintenance instructions:

a. Use #000 sandpaper to remove corrosion.

b. Use a clean, dry, lint-free cloth or a dry brush for most cleaning purposes.

(1) When necessary, use a cloth moistened with solvent (SD) to clean metallic parts except electrical contacts. Wipe solvent (SD) and dirt from the part with a clean, dry cloth.

(2) Use a flushing action when cleaning electrical contacts. Dip an orange stick into Cleaning Compound and allow the liquid to drip from the stick through the contacts. Remove the Cleaning Compound from the contacts carefully with a clean, dry cloth.

Warning: Prolonged breathing of fumes from Cleaning Compound or solvent (SD) is dangerous. Be sure

that adequate ventilation is provided. Cleaning Compound and Solvent (SD) are flammable; do not use near a flame.

c. If available, use vacuum cleaning equipment for removing loose dirt and other foreign matter from the teletypewriter set. Compressed air may be used, but pressure must be kept below 60 pounds per square inch to prevent equipment damage.

44. Special Cleaning Instructions

a. *Parko-Lubricized and Parkerized Parts.* Parts with a black metallic finish have a protective corrosion-resistant finish. Do not immerse these parts in a cleaning fluid longer than is necessary to remove the dirt. Extended immersion is harmful to the protective finish. After such cleaning, lightly spray these parts with Lubricating oil, general purpose (OGP) (lightweight preservative oil).

b. *Oil-Impregnated Bronze Parts.* Do not immerse oil-impregnated bronze (oilite) bearings and other oil-impregnated parts in solvent (SD). Such immersion will dissolve the impregnated oil. Brush away loose dirt with a stiff brush and wipe the part clean with an oil-soaked cloth.

c. *Ball Bearings.* All ball bearings used on the teletypewriter are sealed. Make no attempt to lubricate them. Use a clean, dry cloth to wipe dirt from the outer surfaces of the bearings. Discard any bearings that do not spin freely.

d. *Selector-Magnet Coils.* Clean the coils of the selector magnet with a clean cloth dampened with Cleaning Compound. Clean rust from the pole pieces with #000 sandpaper, and then recoat them with a thin film of lacquer (part of MK-2/GSM (par. 40)).

e. *Felt Friction Plates.* Replace dirty or gritty felt friction plates. Do not attempt to clean them. When overhauling the teletypewriter, replace all felt friction plates with new ones.

45. General Preventive Maintenance Procedure

Perform preventive maintenance on the major assemblies of the teletypewriter as follows:

MAINTENANCE CHECK LIST FOR SIGNAL EQUIPMENT TELETYPEWRITER <small>(AR 750-625)</small>			
EQUIPMENT NOMENCLATURE TELETYPEWRITER SET AN/PGC-1			
EQUIPMENT SERIAL NUMBER 1278			
INSTRUCTIONS			
<p>This form may be used for a period of one month by using the correct dates and weeks of the month. It is to be used as a Preventive Maintenance check list for Signal equipment in actual use, or for a check on equipment prior to issue.</p>			
<p>1. For detailed Preventive Maintenance instructions see:</p> <ul style="list-style-type: none"> a. The Technical Manual (in TM 11 series) for the equipment. <small>(See DA Pamphlet Number 310-4)</small> b. The Supply Bulletin (SB 11-100 series) for the equipment. <small>(See DA Pamphlet Number 310-4)</small> c. The Department of the Army Lubrication Order. <small>(See DA Pamphlet Number 310-4)</small> 			
<p>2. The following action will be taken by either the Communications Officer/Chief for 1st echelon, or the Inspector for higher echelon:</p> <ul style="list-style-type: none"> a. Enter Equipment Nomenclature and Serial Number. b. Strike out items that do not apply to the equipment. 			
<p>3. Operator/Inspector will enter in the columns entitled CONDITION, on the proper line, a notation regarding the condition, using symbols specified under LEGEND.</p>			
<p>4. After operator completes each daily inspection he will initial over the appropriate dates under "Daily Condition for Month", then return form to his supervisor.</p>			
TYPE OF INSPECTION			
OPERATOR	2/3 ECH-ELON	DATE	SIGNATURE
	✓	16 FEB '59	<i>Charles Jones</i>

Figure 62. DA Form 11-252, pages 1 and 4.

a. Dust Cover.

- (1) Remove and inspect the dust cover thoroughly. Look for dents, cracks, marred painted surfaces, loose or missing screws, and faulty hinges. See that the copy holder is in good condition.
- (2) Check all screws for tightness.
- (3) Clean the outer surfaces of the dust cover with a piece of cheesecloth slightly dampened with water. To remove oil, grease, or gummy stains on the surface of the cover, moisten the cloth slightly with solvent (SD).

b. Motor.

- (1) The motor should turn freely, smoothly, and quietly when turned by hand and when under power. Check the motor for evidence of overheating. This may be indicated by an odor of burned insulating material. Check the governor, governor cover, and target for looseness. Tighten the mounting screws firmly.
- (2) Clean the motor as follows:
 - (a) Use an oval brush to remove dust and dirt from the exterior of the motor. Remove all oil and gummy deposits from the exterior with a cloth slightly dampened with solvent (SD).
 - (b) To clean the internal parts of the motor, disassemble the motor (par. 74a) and proceed as follows:
 1. Remove all dust and dirt carefully with an oval brush.
 2. Remove all oil, greasy, or gummy deposits from the armature and from both field windings with a cloth slightly dampened with Cleaning Compound.
 3. Clean the motor brushes and governor contacts with Cleaning Compound; if worn, replace them.
 4. Clean all parts made entirely of metal by immersion in a container of solvent (SD). Reassemble the motor (par. 74c).
- (3) Apply lubrication, where necessary, to the governor of the motor at the points shown in figure 72.

c. Cords, Cables, and Wiring.

Caution: Do not allow oil or solvent (SD) to come in contact with rubber insulation. Oil or solvent (SD) causes deterioration of rubber.

- (1) Check all wiring for cracked or deteriorated insulation. Look for frayed or cut insulation at connecting or support points, kinks. Look for strain caused by improper placement of wiring.
- (2) Tighten loose fasteners, clamps, and wiring connections. Repair loose or broken connectors. Remove corrosion, rust, dirt, or dust from ground connections. Be sure that the outer insulation cover on cords and cables is wiped clean. Renew the weatherproof coating on any fabric-covered wires that require it. Use moisture proofing and Fungiproofing Kit MK-2/GSM.
- (3) Where necessary, position wiring to prevent its interference with the operation of mechanical parts. Resolder loose connections and replace worn or damaged wiring.

d. Terminal Boards.

- (1) Inspect the terminal boards for cracks, breaks, and loose connections. Examine the connections for mechanical defects (broken or stripped screws and threads), dirt, grease, and corrosion. Tighten loose screws, lugs and mounting bolts. Be careful not to strip the threads by exerting too much force. Solder loose or broken connections.
- (2) Remove moisture with a dry cloth. Brush off dirt and dust. Remove oil or gummy deposits from terminal boards with a cloth moistened with Cleaning Compound.

e. Switches.

- (1) Check the mechanical action of each switch. Operate each switch to see that it moves freely. Note the amount of spring tension and inspect for insufficient contact pressure where applicable. Tighten loose screws, lugs, or mounting bolts. Remove loose connections that are dirty or corroded and clean them before tightening or soldering.

bles, and Wiring.

allow oil or solvent
with rubber insulation
causes deterioration of
all wiring for cracked
insulation. Look for
insulation at connecting
joints, kinks. Look for
by improper placement

loose fasteners, clamps
connections. Repair loose
connectors. Remove corrosion,
dirt, or dust from ground
connections. Be sure that the outer
cover on cords and cables is
clean. Renew the weathering
on any fabric-covered
connections. Use moisture proofing
Kit MK-2/G if necessary, position wiring
to prevent its interference with the
operation of mechanical parts. Resolder
connections and replace worn
wiring.

terminal boards
connections, and loose connections
the connections for mechanical
parts (broken or stripped
threads), dirt, grease,
and corrosion. Tighten loose screws,
nuts, and mounting bolts. Be careful
not to damage the threads by exerting
excessive force. Solder loose or broken
connections. Remove moisture with a dry
cloth and dust. Remove any deposits
from terminals with a cloth
moistened with Cleaning Compound.

mechanical action of
operate each switch to
operate freely. Note the amount of
tension and inspect for
contact pressure where
connections. Tighten loose screws,
nuts, and mounting bolts. Remove
loose connections that are dirty or
corroded. Clean them before
tightening.

- 2) Wipe off any moisture present. Clean the exterior surfaces of the switches with the oval brush. Use Cleaning Compound to remove dirt from switch contacts. Polish the contacts with a contact burnisher. If contacts are pitted or burned, use a contact file to restore the surfaces before polishing them with the burnisher.

Keyboard-Transmitter.

- (1) Remove the keyboard-transmitter (par. 61a). Inspect for the following:
 - (a) Cracks or other damage to the keyboard-transmitter frame.
 - (b) Loose, missing, worn or broken nuts, bolts, screws, or fastenings.
 - (c) Damaged, broken, or binding levers, pawls, latches, code bars, and springs.
 - (d) Missing, broken, or illegible keytops.
 - (e) Worn, burned, or dirty contacts, loose electrical connections, frayed, broken or oil-soaked wiring or insulation.
- (2) Do not tighten parts that require clearance or tension adjustments. Tighten all screws and bolts that are not part of an adjustment.
- (3) Clean the keyboard-transmitter as follows:
 - (a) Clean the keytops with a cloth moistened with water.
 - (b) Blow out or brush away dirt or dust that may have accumulated in the keyboard-transmitter mechanism and around the levers code bars.
 - (c) Burnish or file the contacts of the transmitter mechanism if they are dirty or pitted. Clean them thor-

oroughly with Cleaning Compound after filing or burnishing.

- (d) Lubricate the keyboard-transmitter as described in paragraphs 46 through 50.

g. Page Printer. The page printer includes the selector mechanism, platen, carriage, and mainframe mechanisms.

- (1) Perform the applicable maintenance checks listed on DA Form 11-252.
- (2) Examine all operating mechanical assemblies for signs of wear, lack of lubrication, accumulations of dirt or grime, and undesired looseness of any operating parts.
- (3) Clean all assemblies to remove any lubricant that may have dripped from lubrication points. This check provides a good indication as to whether too much lubricant was applied during the last routine servicing.
- (4) Check the condition of the ribbon. If the top edge of the ribbon appears frayed and the rest of the ribbon is serviceable, check the ribbon-lifter adjustment (par. 227).
- (5) Check the type pallets for dirt deposits in the character symbols. To clean the pallets, carefully insert a piece of paper between the type bars and the type-bar backstop and brush them lightly with a toothbrush-style brush slightly dampened with solvent (SD). Check the small center areas of letters such as O, Q, D, G, B, P, and R to make certain that no dirt remains.
- (6) After performing all other maintenance checks, lubricate the assemblies as described in paragraphs 46 through 50. Remove excess lubricant.

Section III. LUBRICATION

Recommended Lubricants

Use the following lubricants to lubricate the operating mechanical parts:

- a. Oil, lubricating (KS7470), Signal Corps stock No. 6G1325 (1-qt can).
- b. Grease (KS7471), Signal Corps stock No. 6G50 (1-lb container).

47. Recommended Lubrication Schedule

The recommended lubrication intervals for each of the four operating speeds are indicated in the following chart. Check each lubrication point carefully; lubricate only when necessary.

Caution: Do not overlubricate. Excessive lubricant is a common cause of damage to rubber parts and wire insulation.

Operating speed (wpm)	Operating time (hours per day)	Lubrication interval (days)
60	8 or less	30
	8 to 12	20
	12 to 16	15
	16 to 24	10
66	8 or less	27
	8 to 12	18
	12 to 16	13
	16 to 24	9
75	8 or less	24
	8 to 12	16
	12 to 16	12
	16 to 24	8
100	8 or less	18
	8 to 12	12
	12 to 16	9
	16 to 24	6

48. Preparation for Lubrication

To prepare the teletypewriter for lubrication, remove it from service and partially disassemble it (*a* below).

a. Disassembly for Lubrication.

- (1) Disconnect the power and signal line cables.
- (2) Remove the dust cover (par. 57).
- (3) Remove the roll of paper and the paper shaft (par. 58).
- (4) Remove one paper-shaft mounting bracket and the paper chute (par. 58).
- (5) Remove the spare worm gear bracket, gear cover, and gasket (par. 60a(1)).

- (6) Remove the keyboard-transmitter (par. 61).
- (7) Remove the transmitter contact cover.
- (8) Remove the motor-governor cover (par. 74a(7) and (8)).

b. Old Lubricants. Remove all old grease and oil with a clean, dry, lint-free cloth. Wrap the cloth around the end of a screw driver or the orange stick to remove the old lubricants from hard-to-reach places.

49. Methods of Applying Lubricants

a. Applying Grease (KS7471). Use the grease gun supplied in the TE-50-B to lubricate gears. Hold the nozzle of the grease gun against the gear teeth at a 45° angle. Operate the handle and turn the gear slowly until the amount of grease specified in the lubrication charts below is applied.

b. Oiling Teletypewriter Mechanisms. To apply only 1 or 2 drops of oil, use the pen-shaped lubricator supplied in the TE-50-B or dip a piece of #22 wire into the oil 1/2 inch and immediately touch it to the desired lubrication point. This method prevents over-lubrication. Where more than 1 or 2 drops of oil are required, use the hand oiler which is also supplied in the T-50-B.

50. Detailed Lubrication Instructions

The points to be lubricated, the type of lubricant to be used, and the quantity to be applied are listed in *a* through *e* below. Item numbers in the charts correspond with the item numbers in the reference illustrations.

Fig. No.	Item No.	Name of part	Method and quantity
64	12	Carriage-return driving and driven gears	} Apply sparingly around gear teeth.
64	19	Rangefinder gear train	
64	24	Square-shaft sliding gear	
65	8	Motor worm and main-shaft driving gear (inside motor-gear housing).	} Work grease around worm and gear, and cover gear teeth liberally.
66	2	Carriage-rack driving gear	
66	6	Function-shaft driving gear	
66	7	Square-shaft driving gear	
66	19	Function-shaft driving gear	} Apply sparingly around teeth.
66	21	Carriage-feed worm	
66	25	Carriage-return-shaft drive gears	
66	26	Transmitter-shaft driving gear	
68	9	Ribbon drive gear	
68	17	Guide rail	} Apply sparingly to rail teeth.
69	4	Carriage rack	

d-transmitter
 cover.
 vernor cover
 old grease and
 th. Wrap the
 ew driver or
 old lubricants
 cants

Use the
 50-B to lubri-
 he grease gun
 ngle. Operate
 owly until the
 he lubrication

hanisms. To
 use the pen-
 e TE-50-B or
 oil 1/2 inch and
 ed lubrication
 er-lubrication.
 of oil are re-
 h is also sup-

ctions
 he type of lu-
 tivity to be ap-
 ow. Item num-
 with the item
 tions.

and cover gear

Note. All ball bearings in the teletypewriter are sealed and require no lubrication.

a. Gears and Racks. Wipe the old grease from the gears and racks with a clean, dry, lint-free cloth. Apply fresh grease (KS7471).

b. Friction Clutches. Apply oil as indicated in the following chart. Do not release the compression of the friction clutch spring during routine lubrication. If spring compression has been released as a result of another maintenance procedure (replacement of clutch part, etc), proceed as follows:

- (1) Oil the felt friction plates of the clutch.
- (2) Adjust the clutch for the required spring compression (par. 145, 146, 174, 175, 219, 220, or 225).
- (3) Operate the teletypewriter for approximately ten minutes.
- (4) Recheck, and if necessary, readjust the spring compression to obtain the proper clutch torque.

Fig. No.	Item No.	Name of part	Method and quantity
64	1	Carriage-feed friction clutch.....	} 10 to 15 drops around periphery of each felt friction plate; apply sparingly to clutch spring and drive collar. Several drops around periphery of each felt friction plate.
64	10	Keyboard-transmitter friction clutch.....	
66	16	Selector-camshaft clutch.....	
66	17	Function-shaft friction clutch.....	
64	9	Carriage-return friction clutch.....	

c. Oil Holes. Apply oil (KS7470) at the following places:

Fig. No.	Item No.	Name of part	Method and quantity
66	4	Function-shaft clutch drum.....	At least 5 drops in hole on either side of drum.
66	11	Code-ring cage.....	At least 5 drops in hole on top of center bearing sleeve (underneath stop bars).
66	20	Carriage-feed driven gear.....	At least 5 drops in hole in gear hub.
69	7	Type-selecting-arm bearing cap.....	At least 5 drops in hole in cap.

d. Sleeve Bearings. Apply oil (KS7470) at the following bearings:

Fig. No.	Item No.	Name of part	Method and quantity
64	6	Square-shaft bearings.....	Several drops at one end of each bearing.
64	7	Platen-casting eccentric pivots.....	Several drops between each pivot and bearing.
64	13	Carriage-rack drive shaft bearing.....	Several drops at both ends of bearing.
65	4	Function-selecting-arm claw bearing.....	Several drops at both ends of bearing.
65	5	Printing-bail shaft bearings.....	Several drops at one end of each bearing.
66	18	Transfer-lever shaft bearings.....	Several drops at one end of each bearing.
68	1	Platen bearings and shaft.....	Several drops at one end of each bearing and thin film on shaft.
71	6	Cam-stop-lever post.....	Several drops at either end.

e. Moving Parts. Apply oil (KS7470) at the following places:

Fig. No.	Item No.	Name of part	Method and quantity
64	3	Square shaft.....	Thin film all sides, lubricate entire length of shaft.
64	4	Carriage-return operating mechanism.....	2 drops at each pivot point.
64	5	Manual carriage-return mechanism.....	Apply sparingly to all pivots and rubbing surfaces.

Fig. No.	Item No.	Name of part	Method and quantity
64	8	Carriage-return-clutch drum.....	Apply sparingly to teeth and grooves, 2 or 3 drops in each group of spline balls inside clutch.
64	11	Decelerating cam and roller.....	Thin film on working surfaces.
64	14	Carriage-return latch.....	2 drops on pivot; thin film on working surfaces.
64	15	Carriage-feed-clutch lever.....	2 drops at pivot; thin film at each end.
64	16	Margin-bell clapper and pawl.....	1 or 2 drops at each pivot point and at tip of pawl.
64	17	Carriage-feed clutch.....	Apply sparingly to clutch teeth.
64	18	Armature and range dials.....	1 or 2 drops at bearings.
64	20	Armature worm.....	Thin film on teeth; 1 or 2 drops between worm and mounting.
64	21	Carriage-feed-clutch drum and drive collar.....	Apply sparingly to rubbing surfaces.
64	22	Platen lower-case latch.....	1 drop at pivot; apply sparingly to latching surface.
64	23	Line-feed and figures-shift bell crank pivots.....	Several drops between levers and washers.
65	1, 2	Connecting link.....	1 drop at each end.
65	3	Function-selecting arm.....	Apply sparingly to all working surfaces.
65	6	Motor-stop function-lever and signal-bell-clapper pivots.....	2 drops at each pivot point.
65	7	Motor-stop contact lever.....	Thin film on latching surfaces.
65	9	Function-cam follower.....	Apply sparingly to cam groove and bearing of roller.
65	10	Letters-shift and carriage-feed levers.....	2 drops at each pivot.
65	11	Support lever.....	2 drops at each pivot.
65	12	Punch bars.....	Several drops between each bar and guide block.
65	13	Platen latch.....	2 drops at pivot; thin film on working surface at each end.
65	14	Aperture gate.....	2 drops in notch; several drops between gate and guide block.
66	1	Print-bail blade.....	Thin film both sides along entire edge.
66	3	Function-clutch spring.....	Apply sparingly to spring.
66	5	Function-shaft driven gear.....	Several drops at bearing and clutch teeth.
66	8	Figure-shift and line-feed links.....	2 drops at each end of both links.
66	9	Line-feed cam-follower bell-crank pivot.....	Several drops at pivot.
66	10	Figures-shift cam-follower bell-crank pivot.....	2 drops at pivot.
66	12	Code rings.....	Thin film all along inner and outer working surfaces on each code ring.
66	13	Line-feed and carriage-return-cam followers.....	Apply sparingly to rollers, pivots, and all rubbing surfaces.
66	14	Rangefinder cam.....	Thin film on working surfaces.
66	15	Function-sensing cams.....	Thin film on all exposed surfaces.
66	22	Function-clutch latch.....	Apply sparingly to roller and latching surfaces.
66	23	Carriage-feed pawl and ratchet.....	Apply sparingly to ratchet teeth; 2 drops at each pawl pivot.
66	24	Carriage-return blocking lever.....	1 or 2 drops at pivot; apply sparingly to latch surfaces.
66	27	Print-cam follower.....	Apply sparingly to cam groove and bearing of roller and to spring hook.
66	28	Motor-stop contact lever pivot.....	Several drops between pivot shaft and lever sleeve.
66	29	Function-shaft bearing.....	1 or 2 drops at bearing.
66	30	Printing-bail shaft bearings.....	Several drops at either end of both bearings.
67	1	T-levers.....	Apply sparingly on working surfaces.
67	2	Stop bars in code-ring cage.....	2 drops at each end of all stop bars.
67	3	Code-ring locking bail.....	Thin film on latching surface.
67	4	Code-ring locking bail shaft.....	1 drop at each pivot.
67	5	Line-feed detent.....	Several drops at lever point; thin film on detent teeth.
67	6	Single-double line-feed lever.....	1 drop at pivot and detent surface.
67	7	Armature-spring arm shaft.....	1 drop at both ends of shaft.
67	8	Selector-magnet armature bearing.....	Apply sparingly.
67	9	Y-levers, Y-lever detents, friction plates.....	Apply sparingly to all rubbing and bearing surfaces.
67	10	Selector-magnet armature edge.....	Apply sparingly.
67	11	Selector-lever-guide comb.....	Apply sparingly to all rubbing surfaces.
67	12	Selector-levers pivot post, bearings, and washers.....	Apply sparingly to all rubbing and bearing surfaces.
67	13	Orientation-lever pivot and rangefinder cam.....	1 or 2 drops at pivot; thin film on cam surface.

Fig. No.	Item No.	Name of part	Method and quantity
67	14	Grooved pin.....	Several drops between pin and camshaft.
67	15	Selector cams and stop plate.....	Thin film on working surfaces.
67	16	Transfer-lever latch.....	2 drops on pivot; thin film on latching surface.
67	17	T-levers and separating washers.....	Apply sparingly to all rubbing and bearing surfaces.
67	18	Transfer-lever restoring cam.....	1 drop on cam surface.
67	19	Transfer-lever-roller stud.....	Apply sparingly to working surfaces.
67	20	Stop-arm-shaft clutch.....	Several drops in clutch.
68	2, 3	Figure-shift link.....	1 or 2 drops at each pivot.
68	4	Line-feed connecting link.....	1 or 2 drops at each pivot.
68	5	Connecting link.....	1 or 2 drops at each pivot.
68	6	Line-feed lever.....	2 or 3 drops at pivot.
68	7	Single-double line-feed-lever detent.....	2 or 3 drops at pivot.
68	8	Ribbon-reverse beam pivot stud.....	1 or 2 drops at pivot.
68	10	Ribbon-reverse beam detent.....	1 drop at pivot; apply sparingly to latching surfaces.
68	11	Ribbon-feed clutch.....	Apply sparingly to clutch teeth.
68	12	Ribbon-drive shaft.....	Apply sparingly to bearings, cam surfaces, and gear teeth at both ends.
68	13	Ribbon-sensing levers.....	1 or 2 drops at each bearing and pin.
68	14	Spool-shaft gears.....	Apply sparingly to groove, teeth, and driving jaws.
68	15	Ribbon-spool shafts.....	1 or 2 drops at bearings top and bottom.
68	16	Ball bearings and guide rail.....	Apply sparingly to rolling surfaces.
68	18	Line-feed pawl.....	2 drops at pivot.
68	20	Carriage-return bell crank linkage.....	2 drops at each pivot.
69	1	Ribbon-spool lock.....	1 drop at handle pivots.
69	2	Ribbon guide.....	Thin film on sliding surfaces.
69	3	Hinge pin.....	2 or 3 drops at each pivot; apply sparingly to gear teeth.
69	5	Ribbon-lifter bell crank, > turnbuckle.....	1 or 2 drops at pivots.
69	6	Connecting-bar guide plate.....	1 or 2 drops at each guide plate.
69	8	Type-selecting arm.....	Apply sparingly between arm and claw.
69	9	Ribbon-lifter links.....	1 or 2 drops at each pivot.
69	10	Ribbon-lifter pivot bearing.....	Thin film on sliding surfaces.
70	1	Keylevers.....	1 drop at each pivot.
70	2	Space-bar lever pivots.....	1 drop each.
70	3	Code bars and guide studs.....	Thin film all along notched edge of each bar; 2 or 3 drops in each groove.
71	1	Selector levers, bearings and spacers.....	Apply sparingly to all rubbing and bearing surfaces.
71	2	Contact-bail pivot.....	2 or 3 drops between bail and pivot stud.
71	3	Sensing-lever locking bail.....	1 or 2 drops on bail surface and between levers and comb.
71	4	Transmitter camshaft.....	Thin film on all cam lobes and stop teeth.
71	5	Sensing levers.....	Apply sparingly at working surfaces at each end of pivot.
71	7	Cam-stop-lever latch stud.....	2 or 3 drops at pivot points; thin film on latching surface.
71	8	Front keylever guide.....	1 drop in each guide slot.
71	9	Keyboard lock.....	Thin film on sliding surfaces.
72	1	Governor adjustment lever.....	1 or 2 drops at each end.
72	2	Governor adjustment screw.....	Apply sparingly to entire thread.
72	3	Speed adjustment gear.....	Apply sparingly to gear teeth.
72	4	Governor worm.....	2 or 3 drops in governor hub opening.

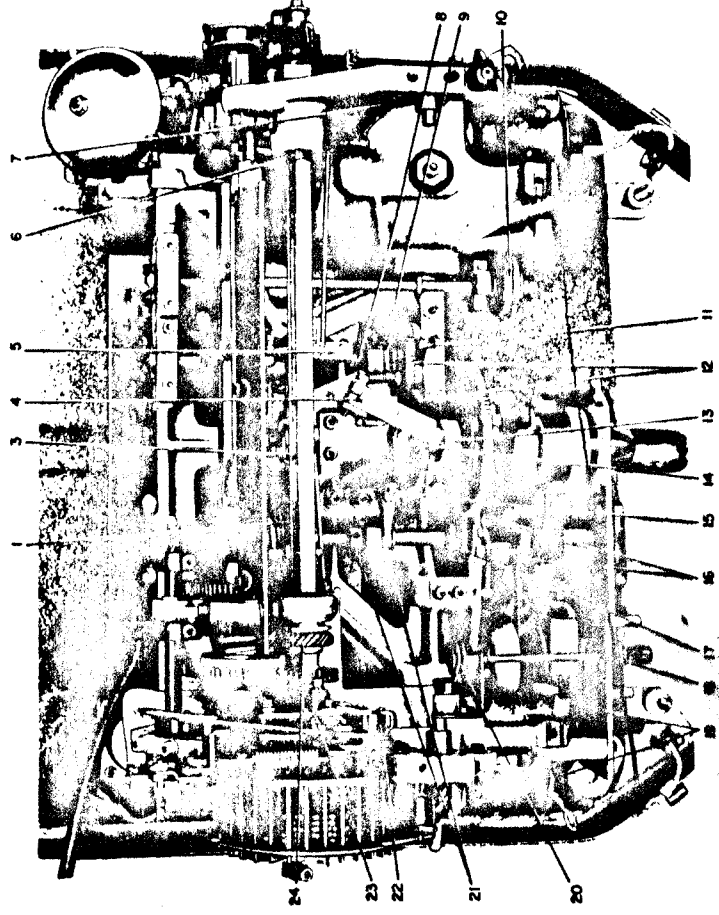

TMS915-206-35-32

Figure 64. Teletypewriter, top view; partially disassembled to show lubrication points.

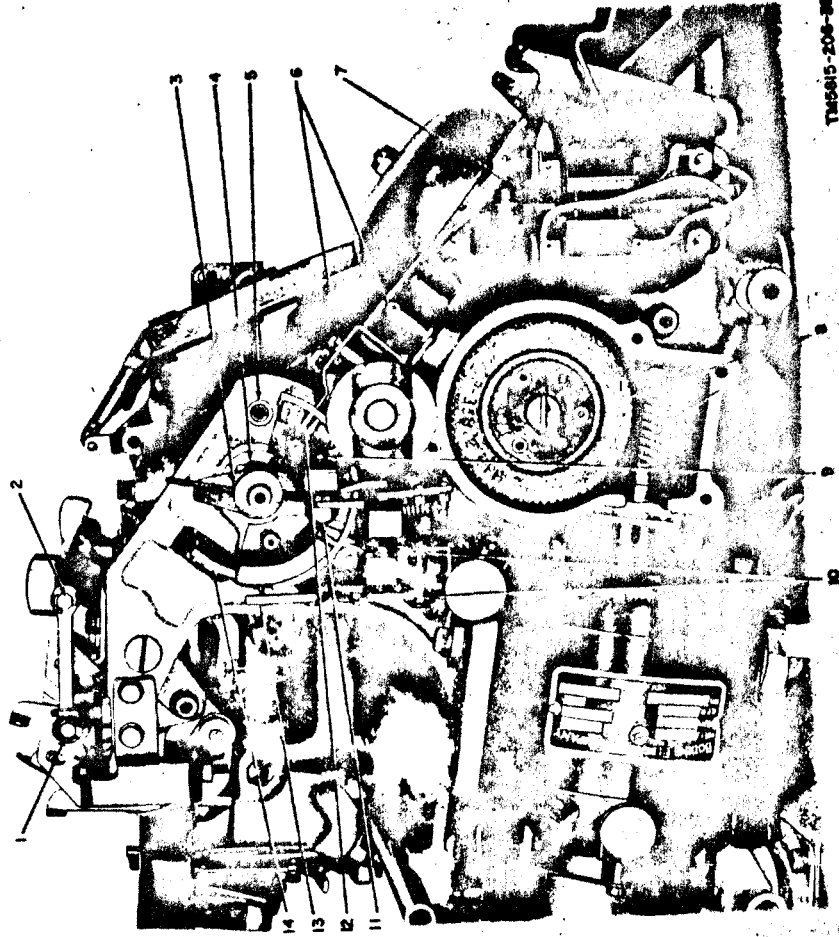

TMS615-206-28-48

Figure 65. Teletypewriter, motor side, lubrication points.

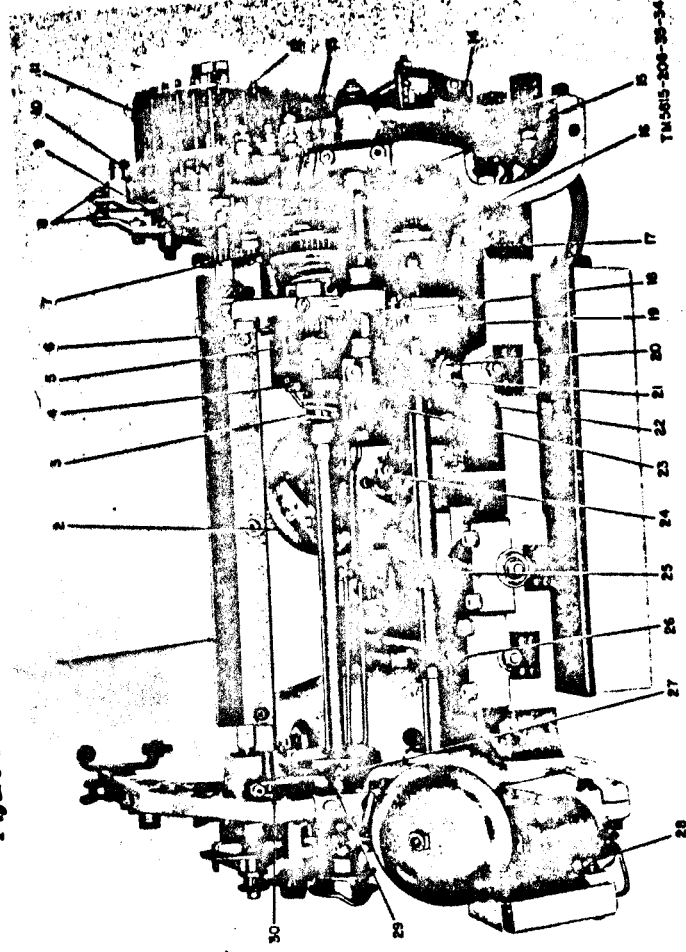

TMS615-206-28-34

Figure 66. Teletypewriter, rear view, lubrication points.



TMS 015-206-35-34

Figure 87. Teletypewriter, selector mechanism side, lubrication points.

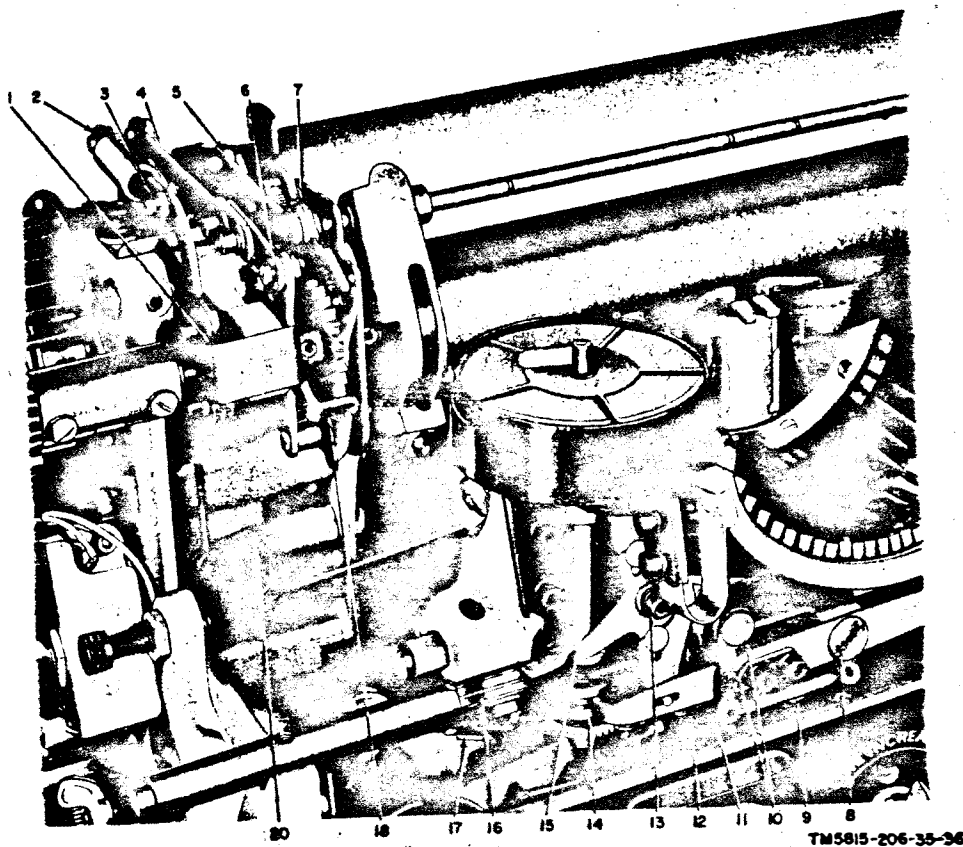

Figure 68. Teletypewriter, left front view, lubrication points.

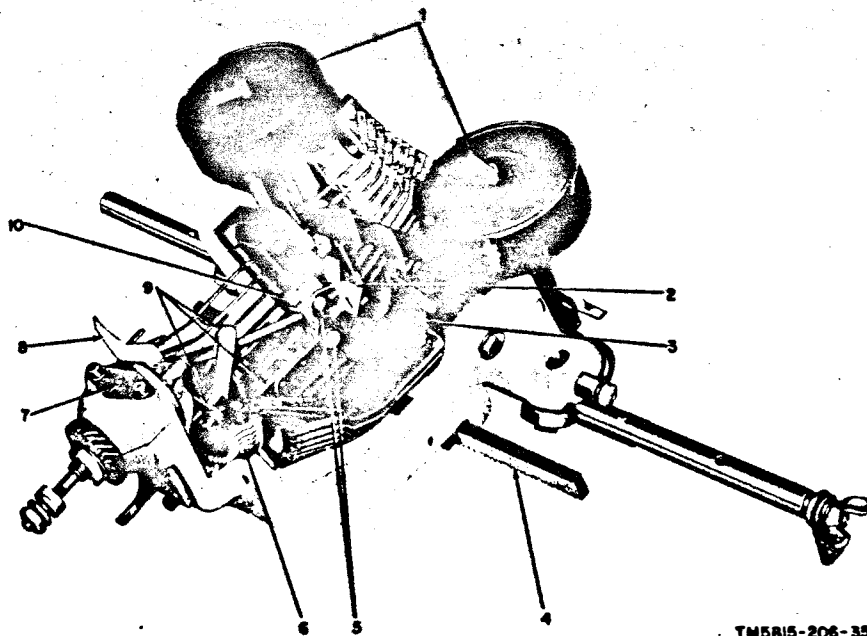
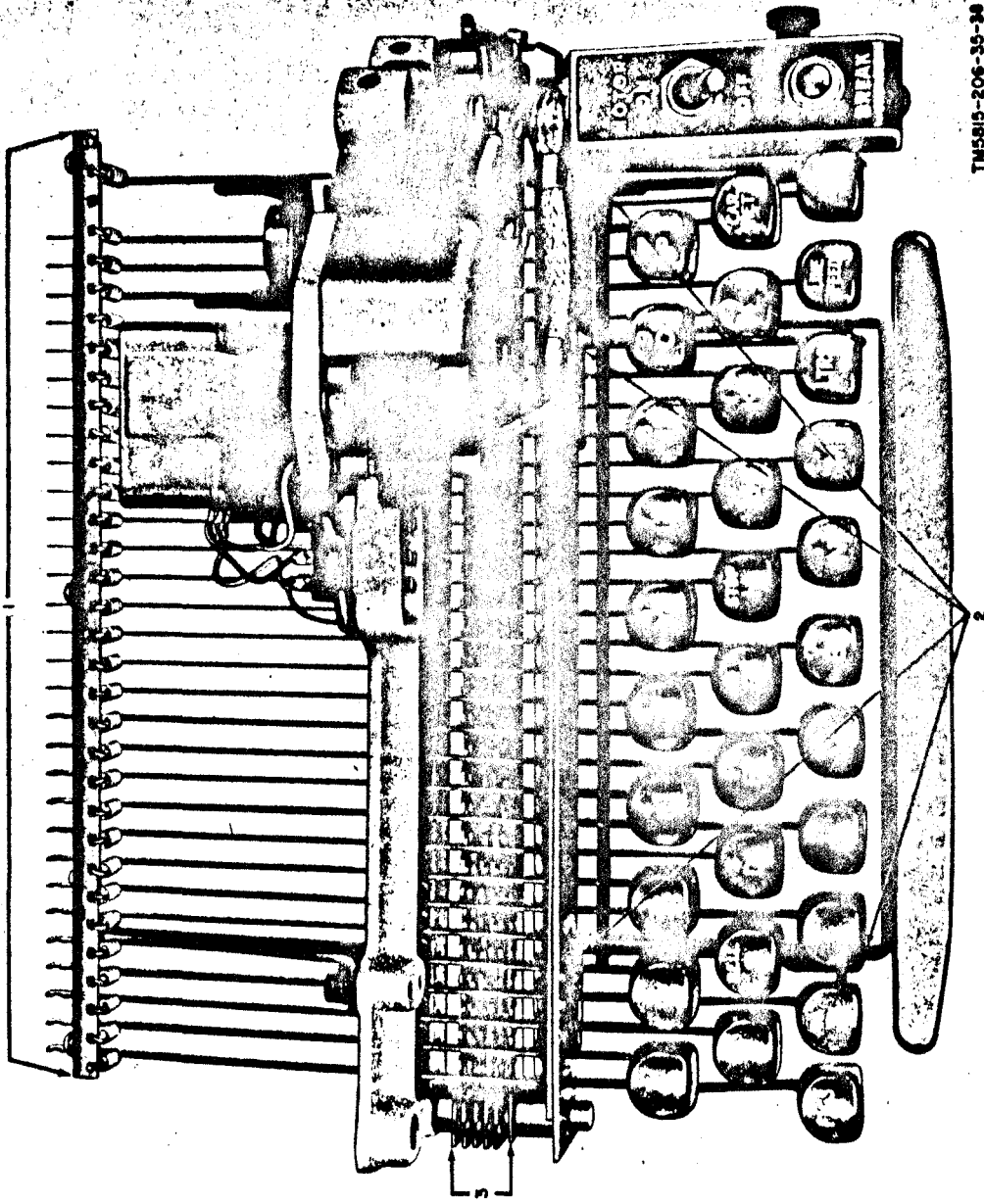
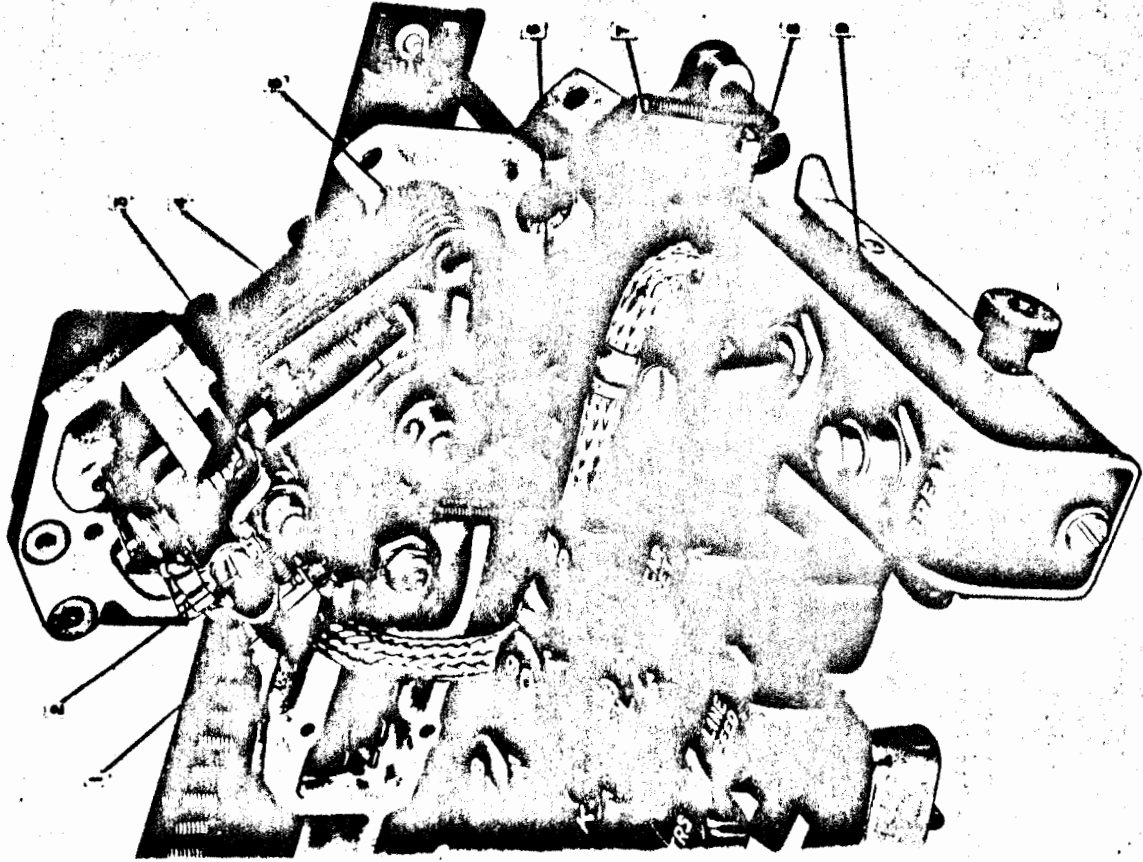

Figure 69. Carriage, rear view, lubrication points.



TM 5818-206-35-34

Figure 70. Keyboard-transmitter, top view, lubrication points.



TM5815-206-35-38

Figure 71. Keyboard-transmitter, right front view, lubrication points.

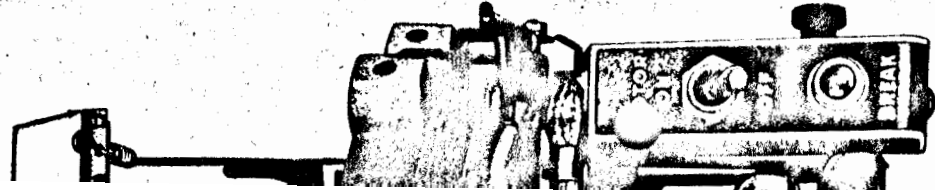

TM5815-206-35-38

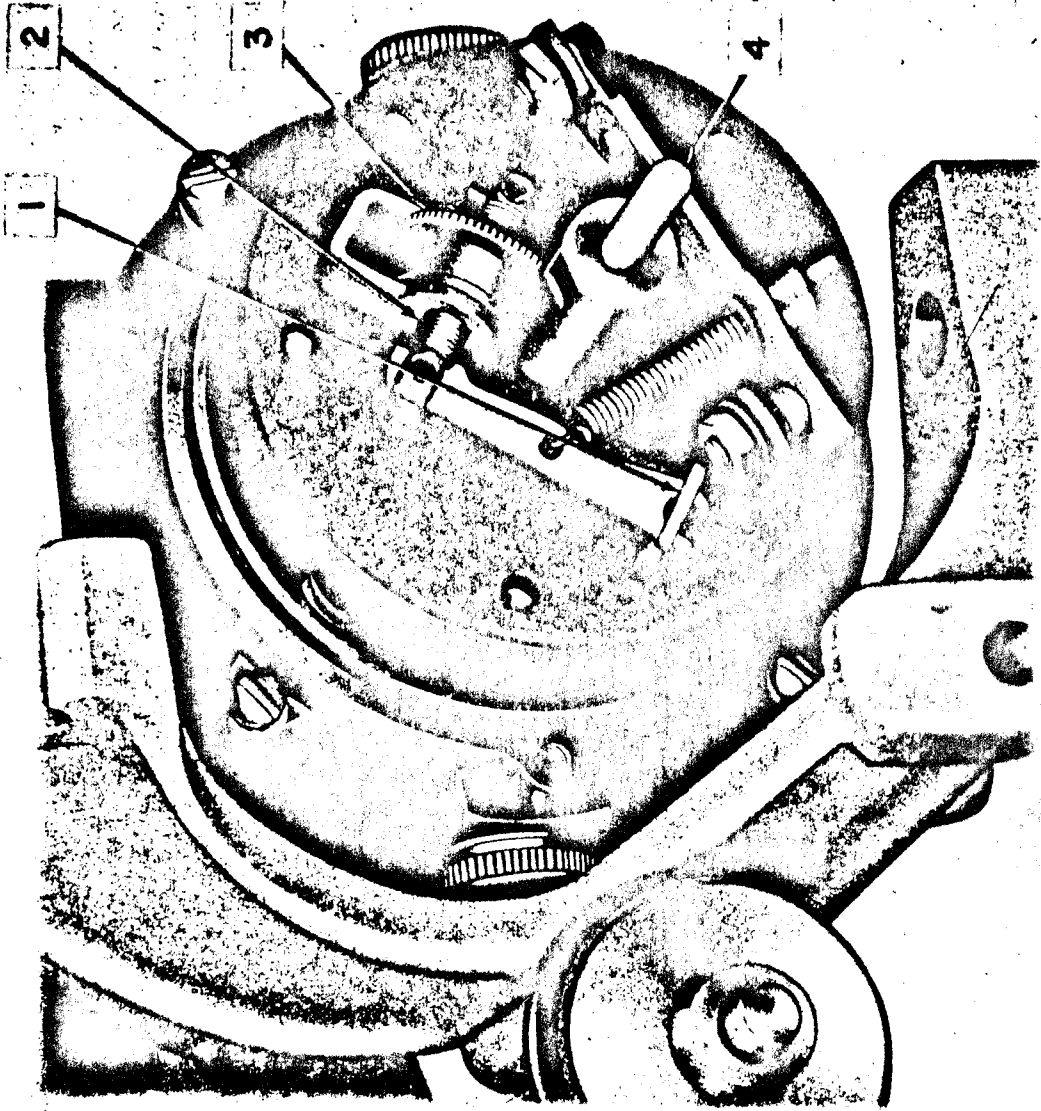

TM5815-206-35-40

Figure 72. Governor lubrication points.

Section IV. TROUBLESHOOTING

51. General

Troubleshooting at field and depot levels includes all the troubleshooting techniques outlined for organizational maintenance (TM 11-5815-206-12) and any special or additional techniques required to isolate a defective circuit, part, or adjustment. The systematic troubleshooting procedure, which begins with the operational checks performed at organizational level, must be completed by means of sectionalization, localization, and isolation procedures. Sectionalization, the first step in troubleshooting, means tracing the trouble to the major component that is responsible for abnormal operation. Localization, the second step, means tracing the trouble to a particular subassembly or circuit within the major component. Isolation, the third step, means tracing the trouble to the defective part or adjustment.

52. Sectionalizing Trouble

When a teletypewriter that is connected for *half-duplex* operation in a teletypewriter communications system does not operate properly, use the substitution method to sectionalize the trouble (*a* below). If a substitute teletypewriter is not available, follow the procedures described in *b* below. If it is suspected that a fault exists in a teletypewriter that is not connected to a communications system, locate the trouble as described in *c* below. If the teletypewriter is connected for *full-duplex* operation, and the fault is not immediately apparent, remove the teletypewriter from service and perform a local test of the teletypewriter (*c* below). If it meets all performance requirements, the fault is in either the external signal circuit or in other equipment in the system.

a. Substitution Method. Substitute a teletypewriter, which is known to be in good operating condition, for the local teletypewriter in the system.

- (1) If the trouble still exists, the fault is either in the signal circuit or in other teletypewriter equipment in the communications system.
- (2) If use of the substitute teletypewriter restores communication, the teletypewriter that was removed from the system is defective. In this case, fol-

low the instructions in subparagraph *c* below.

b. Test Signal Exchange Method. If a substitute teletypewriter is not available, transmit test signals (alternate R and Y code groups) from the local keyboard and note the operation of the page printer. Then have an operator at any of the other stations in the system transmit test signals and note the operation of the page printer.

- (1) If the local page printer operates properly when test signals are transmitted from the local keyboard-transmitter but does not operate properly when the test signals are transmitted from another station, the fault is either in the signal circuit or in the teletypewriter equipment at the other station.
- (2) If the local page printer does not operate properly when the test signals are transmitted from the local keyboard-transmitter but does operate properly when the test signals are transmitted from any of the other stations in the system, the fault is in the local keyboard transmitter.
- (3) If the local page printer does not operate properly regardless of the source of test signals, the trouble is in the local page printer.
- (4) If the fault is determined to be in the local teletypewriter, follow the instructions in *c* below.

c. Local Test Method. Connect the teletypewriter for local test (fig. 73) and check the performance of the teletypewriter (par. 39, TM 11-5815-206-12). If the performance checks do not reveal the fault, make the tests described in paragraphs 53 through 55.

53. Localizing Electrical Troubles

Most electrical troubles occur at the various contacts and connection points in the teletypewriter. Test all connection points in a circuit for looseness. The circuits of the teletypewriter include binding posts and connectors at points that are appropriate meter test points. When testing for loose connections and making meter tests, do not disturb the wiring more than

is necessary for the test. Make the following tests to locate an electrical trouble.

a. Power Sources.

- (1) Check to be sure that the voltage of the signal circuit power source is 105- to 125-volts dc.
- (2) Check to be sure that the voltage for the motor circuit is 105- to 125-volts either dc or 50- to 60-cps ac.

b. Local Test Connections. Turn the LINE INCREASE knob fully counterclockwise and make the following connections:

- (1) *Signal circuit* (fig. 73).
 - (a) Connect 105- to 125-volt dc to terminals No. 1 and 4 (positive polarity to terminal 4).
 - (b) Connect one shorting bar across terminals No. 5 and 6.
 - (c) Connect the other shorting bar across terminals No. 2 and 3.
- (2) *Motor circuit.* Connect the motor power cord to a source of 105- to 125-volt either dc or 50- to 60-cps ac.

c. Open in Signal Circuit. When the teletypewriter is connected for local test (b above), the D. C. MILLIAMPERES meter should indicate a flow of current. If no current flows, the signal circuit within the teletypewriter is not complete. Disconnect power from the teletypewriter and check the continuity of the send and receive circuits (e below).

d. Short in Signal Circuit. When the teletypewriter is connected for local test (b above) and the page printer and the pointer of the D. C. MILLIAMPERES meter remain motionless when the keys of the keyboard-transmitter are pressed, check for a short circuit across the transmitter contacts in the send circuit. If the pointer of the meter moves toward zero each time a keylever is pressed, but the page printer remains motionless, check for a short circuit across the selector-magnet coils.

e. Resistance and Continuity Tests. Use Multimeter TS-297/U or a suitable substitute test set when making continuity and resistance tests. Be sure to disconnect parallel electrical paths across the points under test.

- (1) *Continuity test.* Use the continuity test to locate an open in a circuit. Before making a point-to-point check of the complete circuit, check for con-

tinuity across those portions of the circuit where an open is most likely to occur (switch contacts, plug and receptacle connections, etc). If the location of the open is not located quickly in this manner, start at one end of the circuit and make a point-to-point check of the complete circuit.

- (2) *Component resistance tests.* The resistance measured across the test points listed below must be within 10 percent of the value indicated in the chart.

Component	Test points (fig. 58 and 59)	Resistance (ohms)	
		TT-4A/TG	TT-4B/TG
Selector-magnet coils.	Line terminal 3 and center terminal of R2 with: LINE switch in VOICE FREQ position.	90	90
	LINE switch in D. C. position.	360	360
Motor-stop-relay coils.	Line terminal 4 and either terminal of fuseholder XF2 with motor-stop-relay contacts 1 and 4 (TT-4A/TG) and contacts 1 and 2 of S5, (TT-4 B/TG):		
	Open..... Closed.....	360 0	300 0

f. Capacitor Test.

Caution: Before testing a capacitor, always place a momentary short circuit across the capacitor terminals to remove any charge present in the capacitor. Be extremely careful when discharging the capacitor; severe electrical shock may be received from a charged capacitor.

Disconnect one lead from the capacitor and connect the TS-297/U (arranged to read maximum resistance) across the capacitor terminals. If the pointer of the test set moves toward zero quickly and then slowly returns toward the infinity mark, the capacitor is good. If the pointer does not move toward zero, or if it does move, but does not return to the infinity mark, replace the capacitor.

portions of the is (st likely s, plug and re- ce). If the lo- s not located , start at one make a point- nplete circuit. tests. The re- ss the test st be within 10 ndicated in the

Resistance (ohms)	
4A/TG	TT-4B/TG
90	90
360	360
360	300
0	0

capacitor, always across the ca- charge present careful when vere electrical arged capacitor. e capacitor and d to read max- capacitor terminals. moves toward returns toward is good. If the zero, or if it to the infinity

54. Localizing Mechanical Troubles

When the cause of a mechanical trouble is not apparent:

- a. Turn the motor off.
- b. Press a keylever and turn the governor target clockwise manually to rotate the motor.
- c. As rotation of the motor causes the transmission of each impulse of the code group, make the following checks:

- (1) Check the operation of the keyboard-transmitter train of parts that is associated with the impulse.
- (2) Check the effect of each impulse on the D.C. MILLIAMPERES meter and on the position of the selector-magnet armature.
- (3) Check the operation of the selector mechanism train of parts that is associated with the impulse.
- (4) Check the transfer operation.
- (5) Check the positioning of the type-selecting arm and the function-selecting arm.

a. Keyboard - Transmitter Troubleshooting Chart.

Condition	Probable trouble	Correction
Downward movement of a key lever does not cause transmission.	Send circuit shorted	Check send circuit (fig. 58 and 59).
	Keyboard-transmitter contacts out of adjustment. Keyboard-transmitter plug (J2) disconnected. Keyboard-transmitter friction clutch out of adjustment.	Adjust contacts (par. 147). Connect keyboard-transmitter plug to connector P2. Adjust friction clutch (par. 145 and 146).
Transmitter camshaft rotates continuously.	Cam-stop lever binding	Clean cam-stop lever and its post (fig. 79).
	Locking-lever-latch spring broken or disconnected. Universal-bar adjusting screw out of adjustment.	Replace or connect locking-lever-latch spring (fig. 78). Adjust settings of universal-bar adjusting screw (par. 139).
Transmitter mechanism transmits incorrect code groups.	Repeat-blocking-lever spring broken or disconnected.	Replace or connect repeat-blocking-lever spring (fig. 78).
	Friction clutch dry or out of adjustment.	Lubricate (par. 50) and adjust (par. 145 and 146). Replace felt friction plate if necessary.
	Transmitter contacts dirty or out of adjustment.	Clean and adjust transmitter contacts (par. 147).
	Contact-bail spring weak	Replace contact-bail spring.
	Binding in selector levers or sensing levers.	Clean and adjust sensing levers and selector levers (par. 141 through 144).

- (6) If the keylever that is pressed is assigned to a character, check the printing operation; if it is assigned to one of the nonprinting operations, check the movement of the train of parts for that operation.

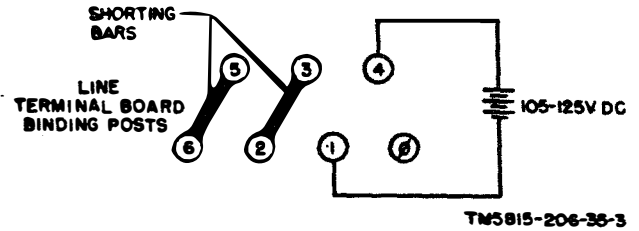

Figure 78. Teletypewriter test connections.

55. Troubleshooting Charts

The most common failures in the teletypewriters, together with the probable cause of the trouble and the corrective actions to be taken, are listed in a and b below.

Condition	Probable trouble	Correction
Keyboard-transmitter operates properly, but causes noise in local radio receivers.	Sensing-lever locking-bail spring weak.	Replace spring.
	Faulty RF filter.....	Check filter; replace if defective (par. 72).
	Faulty RF filter connections.....	Check and replace defective bonding straps; tighten connections.

b. Page Printer Troubleshooting Chart.

Motor fails to start.....	MOTOR fuse blown.....	Replace MOTOR fuse (fig. 58 or 59).
	Failure of power source.....	Correct defect or use another power source.
	Motor-stop contacts dirty or do not close.	Clean and burnish motor stop contacts.
	Dirty commutator on motor.....	Clean commutator (par. 74d).
	Defective motor switch S2.....	Replace S2 (fig. 79).
	Defective motor brushes.....	Replace brushes (par. 74c).
	Open in field or armature winding.....	Repair or replace motor (par. 60).
Motor runs but speed is erratic.....	Mechanical bind.....	Locate and correct trouble in mechanism.
	Governor contacts dirty or pitted.....	Clean, burnish, or replace contacts (par. 75).
	Governor spring broken.....	Replace spring.
Page printer runs open (mechanism runs when line current should be steady marking).	Motor-stop contacts weak or broken.....	Install new motor-stop contacts (par. 123).
	Dirty commutator on motor.....	Clean commutator (par. 74d).
	Line fuse blown.....	Replace line fuse (fig. 58 or 59).
	External line circuit open or shorted	Check line from teletypewriter terminals for continuity or short.
	No line current.....	Correct or replace source of voltage; adjust line current.
	Receive circuit in teletypewriter open or shorted.	Check for continuity or short and repair fault.
	Selector-magnet armature not holding stop lever.	Readjust selector mechanism (par. 183).
	Transfer-lever trip latch spring broken.	Replace transfer-lever trip latch spring.
	Selector camshaft stop plate or stop lever worn or broken.	Replace stop plate or stop lever.
	Rangefinder dial improperly set.....	Adjust rangefinder dial.
Page printer prints errors or scrambles letters and functions.	Selector camshaft friction clutch slipping.	Adjust friction clutch (par. 174 and 175).
	Dirty, binding, or sticking selector mechanism.	Clean or adjust selector parts (par. 142 through 144).
	Worn or broken Y- or T-levers.....	Replace defective levers.
	Selector camshaft stop plate loose.....	Replace worn parts.
	Selector-lever spring broken.....	Replace selector-lever spring.
	Square-shaft friction clutch slipping.	Adjust friction clutch (par. 225).
	Selector-magnet mounting loose.....	Readjust and tighten mounting screws (par. 185).
	Square-shaft stop arm or function-selecting-arm claw loose.	Readjust and tighten (par. 224).

Condition	Probable trouble	Correction
Page printer prints same character or performs same function regardless of signals being sent.	Transfer-lever-trip latch spring or transfer-lever spring broken.	Replace a broken spring.
Certain characters or functions will not print (or operate).	Antibounce clutch on stop-arm shaft jammed.	Replace stop-arm shaft.
	Function-selecting arm sticking in punch-bar guide block.	Clean and readjust if necessary.
Page printer operates, but range (rangefinder measurement) is narrow.	Stop bar sticking.....	Clean stop-bar guide plate and code rings.
	Stop-bar spring broken or missing.....	Replace spring.
Line current too high or too low.....	Line current too high or too low.....	Readjust line current.
	Motor speed incorrect at transmitter.....	Have transmitter motor speed checked.
Selector mechanism improperly adjusted.	Selector mechanism improperly adjusted.	Check requirements of selector mechanism adjustments and readjust as required.
	Connecting-bar spring weak or missing.	Replace spring.
Page printer prints but sticks in print position.	Print mechanism binding.....	Clean and adjust print mechanism.
Platen will not shift.....	Figures-shift sensing-lever spring broken.	Replace spring.
	Platen-latching arm loose.....	Readjust arm and tighten mounting screws (par. 240).
Figures-shift sensing lever or cam follower bent or broken.	Figures-shift sensing lever or cam follower bent or broken.	Replace defective parts.
	Function aperture gate stuck.....	Clean function group parts.
Platen will not shift from figures- to the letters-shift position.	Signal-bell or motor-stop punch bar stuck in operated position.	Clean function group parts.
Platen cannot be prevented from returning to figures-shift position.	Cam-follower spacing collar on mounting stud dirty or improperly placed.	Clean and adjust collar (par. 156).
	Line-feed and figures-shift cam-follower spring broken.	Replace broken line-feed and figures-shift cam-follower spring.
Carriage will not feed.....	Carriage-feed link improperly adjusted.	Readjust link (par. 198).
	Carriage-feed clutch slipping.....	Readjust clutch; replace felt friction plates, if necessary (par. 219).
Driving collar loose.....	Driving collar loose.....	Tighten set screws.
	Carriage-feed-clutch-lever spring broken.	Replace spring.
Ribbon-driving mechanism jammed.....	Ribbon-driving mechanism jammed.....	Readjust ribbon-driving mechanism (par. 252).
	Carriage-feed pawl spring broken.....	Replace spring.
Carriage-return function inoperative.	Carriage-return link improperly adjusted.	Adjust link (par. 201).
	Carriage-return sensing-lever spring broken.	Replace spring.
Carriage-return safety clutch mechanism out of adjustment.	Carriage-return safety clutch mechanism out of adjustment.	Adjust (par. 219).
	Carriage-return latch-tripping arm improperly adjusted.	Readjust latch-tripping cam (par. 204).
Carriage does not make complete return.	Mechanism binding.....	Clean and adjust carriage mechanism.
	Line-feed sensing-lever spring broken.	Replace spring.
Line-feed function does not operate.....	Line-feed pawl spring broken.....	Replace spring.

Condition	Probable trouble	Correction
Line feed occurs on every operation or is erratic.	Line-feed mechanism stuck Cam-follower spacing collar and stud dirty or spacing collar improperly placed.	Clean detent parts. Clean collar and stud and reset collar if necessary.
Signal bell does not ring	Line-feed and figures-shift cam-follower spring broken. Clapper bent	Replace spring. Straighten clapper.
Motor stop fails to operate	Signal-bell punch bar sticks Motor-stop contact lever improperly adjusted.	Clean function group parts. Readjust position of lever lug (par. 263).
Only part of characters print	Motor-stop contacts bent or broken Motor-stop punch bar sticks	Straighten or replace. Clean function group parts.
Printing too light or too heavy	Ribbon lifter not raising far enough. Stop screw for platen bracket not properly adjusted.	Adjust ribbon lifter (par. 227). Adjust platen bracket stop screw (par. 238 and 239).
Lines are not printed straight	Grooved nut on type-selecting arm improperly adjusted. Platen bracket stop screw loose	Adjust (par. 227). Tighten the screw.
Margins printing unevenly	Platen casting eccentric mounting screw not properly adjusted. Carriage-return blocking mechanism improperly adjusted.	Adjust (par. 235). Adjust carriage-return blocking mechanism (par. 210).
Ribbon lifter not working properly	Broken lifter tension spring Dirty, bent, or broken parts	Replace spring. Clean and replace broken parts.
Ribbon does not feed or does not reverse.	Ribbon spool not seated correctly on driving collar or collar loose on shaft. No spring tension on ribbon-feed clutch.	Check seating of spool and tighten collar set screw. Reset collar for proper spring tension (par. 253).
Margin bell does not ring properly	Ribbon-spool gears not meshing Ribbon-sensing lever bent, dirty, or has broken spring.	Replace ribbon-reversing detent spring. Clean, adjust, and replace parts as necessary.
Paper tension roller cannot be released.	Margin-bell-pawl trip arm improperly set or pawl broken. Pawl spring broken	Reset arm or replace broken part. Replace pawl spring.
Page printer emits grinding or whining noise.	Clapper spring broken Clapper bent Pin on roller bent or broken	Replace clapper spring. Straighten clapper. Replace defective pin.
	Paper release mechanism binding	Clean and adjust mechanism (par. 232 and 233).
	Motor drive gears improperly meshed.	Adjust position of motor (par. 270).
	Fouled bearings in motor, main shaft, or function shaft.	Clean and lubricate or replace bearings if necessary.
	Motor shaft or main shaft bent	Replace bent shaft.

Section V. REMOVAL AND REPLACEMENT OF TELETYPEWRITER COMPONENTS

56. General

a. This section describes removal and replacement procedures for the major components of Teletypewriters TT-4A/TG and TT-4B/TG (fig. 74). These procedures are used in conjunction with disassembly and reassembly pro-

cedures described in paragraphs 66 through 133.

b. All repairs should be made by qualified teletypewriter maintenance personnel. Equipment operating with minor faults may fail completely as the result of efforts by inexperi-

enced personnel to correct apparently simple defects.

c. Inspection, cleaning, and lubrication instructions are given in paragraphs 38 through 50. Whenever repairs are made, the teletypewriter should be completely readjusted in accordance with paragraphs 134 through 275.

57. Removal and Replacement of Dust Cover (fig. 74)

a. Removal.

- (1) Push the platen knob (on the left-hand side) inward until it clears the dust cover.
- (2) Loosen the thumb nuts (1 and 5, fig. 127) and disconnect the dust cover grounding leads.
- (3) On the TT-4A/TG, grasp the dust cover at the lower rear corners and tilt the cover forward carefully. When the cover is clear of the two rear studs, lift it free from the two front studs.
- (4) On the TT-4B/TG, turn the cam latches on the left- and righthand side of the dust cover to the open position; lift the dust cover from the mounting base.

b. *Replacement.* Replace the dust cover by reversing the procedures described in *a* above.

58. Removal and Replacement of Paper Shaft, Paper-Shaft Brackets and Paper Chute

a. Removal.

- (1) Remove the dust cover (par. 57).
- (2) Raise the two retaining springs on the two paper-shaft brackets (7 and 12, fig. 123) that hold the paper shaft (1) on the paper-shaft brackets; remove the paper shaft and roll of recording paper.
- (3) Remove the two machine screws (2) and lock washers (3) that hold the paper-shaft bracket (7) to the teletypewriter frame; slide the assembled paper chute (4) and paper-shaft bracket (7) away from the two rubber mounts (10 and 11) of the paper-shaft bracket (12). Remove the paper chute from the paper-shaft bracket (7).
- (4) Remove the two machine screws (8)

and lockwashers (9) that hold the paper-shaft bracket (12); and remove the paper-shaft bracket.

b. *Replacement.*

- (1) Replace the paper shaft, paper-shaft brackets, and paper chute by reversing the procedures outlined in *a*(2), (3), and (4) above.
- (2) Replace the dust cover (par. 57b).

59. Removal and Replacement of Mounting Base

a. Removal.

- (1) Remove the dust cover (par. 57a.).
- (2) Remove the two machine screws (1, fig. 80) that hold the copy-light connector (81) to the mounting base; remove the copy-light connector and insulator (2).
- (3) On the TT-4A/TG, remove the four plain hexagonal nuts (1, fig. 126), lockwashers (2), and flat washers (3) that hold the feet of the frame assembly (50) to the mounting base studs.
- (4) On the TT-4B/TG, remove the two machine screws (4) and lockwashers (5) that hold the frame feet and grounding straps to the mounting base. Back out the machine screws that hold the mounting base on the left hand side.
- (5) On the TT-4A/TG, lift the ends of the four grounding straps (9, fig. 128) clear of the mounting studs.
- (6) Lift the machine clear of the mounting studs; be careful not to snag the lugs of the space bar on the space-bar stops.

b. *Replacement.*

- (1) Replace the mounting base by reversing the procedures outlined in *a*(2) through (6) above.
- (2) Replace the dust cover (par. 57b).

60. Removal and Replacement of Motor Gear Set and Motor

a. *Removal of Motor Gear Set.*

- (1) Remove the four machine screws (6, fig. 126) and lock washers (7) that hold the gear cover (11) and accessory gear set (10 and 13) to the

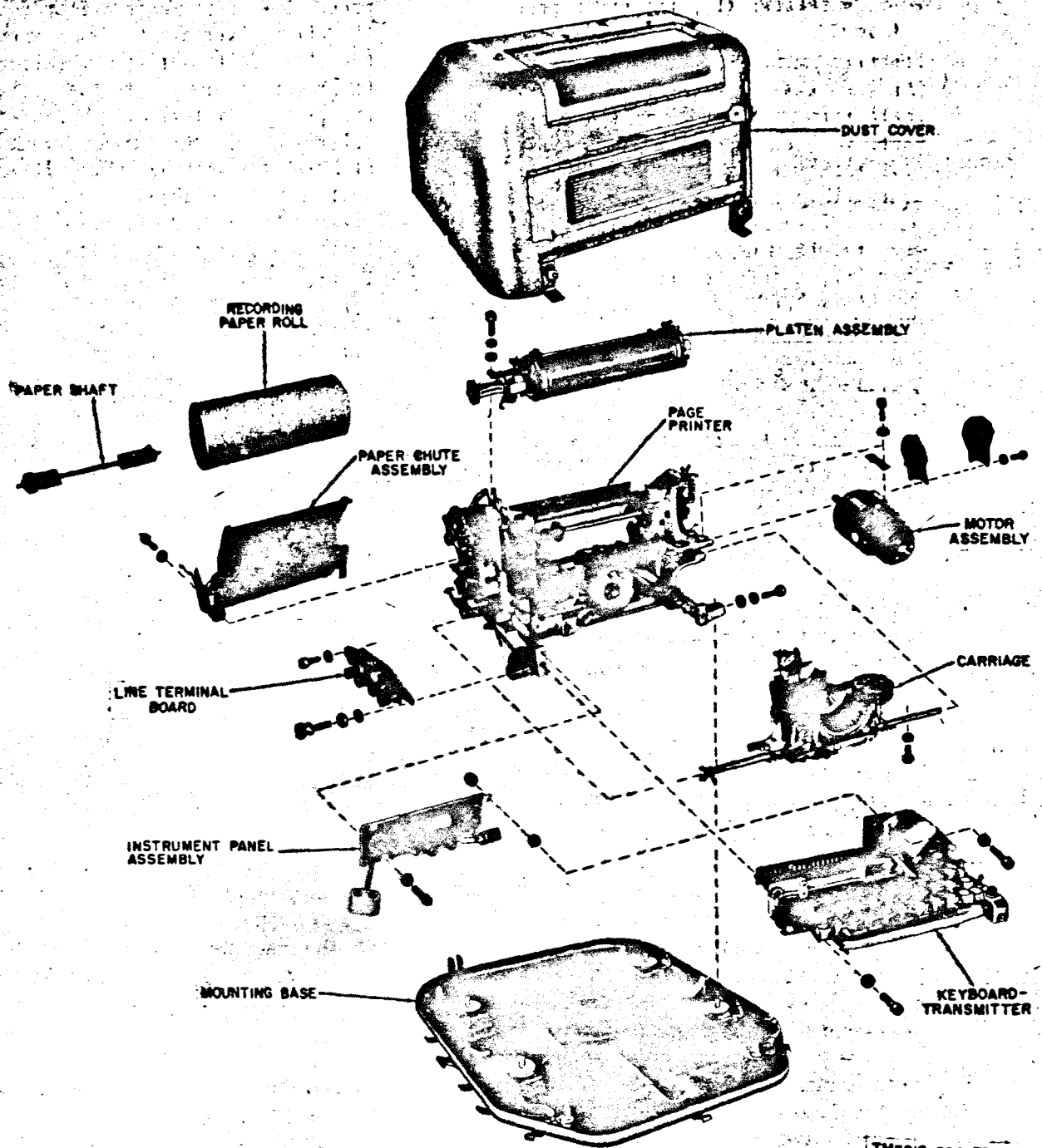

TM5815-206-33-41

Figure 74. Teletypewriter TT-4B/TG components.

- 78
- (2) On the TT-4A/TG, remove the machine screw (1, fig. 104), lockwashers (2), and mainshaft gear (3) from the main shaft (31).
 - (3) On the TT-4B/TG, remove the machine screw (1, fig. 105), lockwasher (2), main-shaft gear (3), and drive keys (4) from the main shaft (22).
 - (4) Remove the motor (c below).
 - (5) Remove the machine screw (8, fig.

81), lockwasher (9), and worm gear (10 or 11).

b. Replacement of Motor Gear Set.

- (1) On the TT-4A/TG, install the main-shaft gear (3, fig. 104) on the main-shaft (31); replace the machine screw (1) and lockwasher (2). Do not tighten the machine screw.
- (2) On the TT-4B/TG, install the drive keys (4, fig. 105) on the main-shaft gear (3); install the main-shaft gear and drive keys on the main shaft (22); and replace machine screw (1) and lockwasher (2). Do not tighten the machine screw.
- (3) Install the worm gear on the armature; replace the machine screw (8, fig. 81) and lockwasher (9); tighten the machine screw.
- (4) Replace the motor (*d* below).
- (5) Tighten the machine screw (1, fig. 104 or 105).
- (6) Replace the gasket (8, fig. 126) and gear cover (11) and accessory gear set (10 and 13) and secure with the four machine screws (6) and lockwashers (7).

c. Removal of Motor.

- (1) Remove the mounting base (par. 59).
- (2) Carefully turn the machine until it rests on the selector side (left side).
- (3) Remove the four machine screws (1, fig. 124) and lock washers (2) that hold the filter box cover (3) on the filter box (62); remove the filter box cover.
- (4) Remove the four motor leads from the terminal board (38); tag the leads to facilitate replacement.
- (5) Turn the machine right side up.
- (6) On the TT-4A/TG, remove the four machine screws (1, fig. 81) and lockwashers (2) that hold the motor to the frame; remove the motor and the shims (3).
- (7) On the TT-4B/TG, remove the three machine screws (4, fig. 81) and lockwashers (5) that hold the motor to the frame; remove the motor.

d. Replacement of Motor.

- (1) Replace the motor by reversing the

procedures described in *c*(2) through (7) above. Be sure that the motor of the TT-4A/TG is properly shimmed to provide running clearance between the gears. Position the grease seals (13 and 14, fig. 81) between the rear of the motor and the frame. Be sure that the main-shaft gear and the worm gear are meshing properly before tightening the mounting screws.

- (2) Replace the mounting base (par. 59b).

61. Removal and Replacement of Keyboard-Transmitter

a. Removal.

- (1) Remove the dust cover (par. 57a).
- (2) Pull the assembled keyboard plug cover and plug (65 and 66, fig. 80) from the receptacle connector (14, fig. 79).
- (3) On the TT-4A/TG, remove the two machine screws (1, fig. 77) and lockwashers (2) that hold the space bar (3) to the space-bar arm (11); remove the space bar.
- (4) On the TT-4B/TG, remove the two machine screws (4, fig. 77) and lockwashers (5) that hold the space bar (6) to the space-bar arm (12); remove the space bar.
- (5) Remove the machine screw (23, fig. 80), lockwasher (24), self-locking hexagonal nut (25), and lockwasher (26) that hold the keyboard-transmitter to the instrument panel.
- (6) Remove the two machine screws (1, fig. 79) and lockwashers (2) that hold the keyboard frame (37) to the typewriter frame.
- (7) Pull the keyboard forward to remove it from the frame; be careful not to bend the clutch fork (23, fig. 79).

b. Replacement.

- (1) Replace the keyboard-transmitter by reversing the procedures described in *a*(2) through (7) above.
- (2) Replace the dust cover as described in paragraph 57b.



the ma-
kwasher
nd drive
(22).

fig.

62. Removal and Replacement of Platen Assembly

a. Removal.

- (1) Remove the dust cover (par. 57a).
- (2) Loosen the wing nut (24, fig. 126) and disengage the platen lock (22) from the platen-locking stud (7, fig. 82).
- (3) On the TT-4A/TG, remove the cotter pin (22, fig. 99) and fiat washer (23) that hold the platen-shift link (26) to the stud on the platen-shift arm.
- (4) On the TT-4B/TG, remove the retainer ring (23, fig. 100) that holds the platen-shift link (25) to the stud on the platen-shift arm (19, fig. 82).
- (5) On the TT-4A/TG, remove the cotter pin (6, fig. 99) and fiat washer (7) that hold the connecting link (13) to the stud on the line-feed lever (40, fig. 82).
- (6) On the TT-4B/TG, remove the retainer ring (5, fig. 100) that holds the connecting link (10) to the stud on the line-feed lever (40, fig. 82).
- (7) On the TT-4A/TG, remove the platen-shift bell-crank spring (18, fig. 99) from the hole in the bracket link (13, fig. 83).
- (8) On the TT-4B/TG, remove the platen-shift bell-crank spring (20, fig. 100) from the hole in the bracket link (12, fig. 84).
- (9) On the TT-4A/TG, remove the two machine screws (1, fig. 83) and lockwashers (2) that hold the bracket link (13) to the teletypewriter frame.
- (10) On the TT-4B/TG, remove the two machine screws (1, fig. 84), lockwashers (3), and fiat washers (2) that hold the bracket link (12) to the teletypewriter frame.
- (11) On the TT-4A/TG, remove the two cotter pins (5 and 10, fig. 83) and fiat washers (6 and 11) that hold the two connecting links (7 and 12) to the platen trough (41); remove the connecting links.
- (12) On the TT-4B/TG, remove the two retainer rings (5 and 10, fig. 84) that hold the two connecting links (6 and

11) to the platen trough (42); remove the connecting links.

- (13) Remove the two setscrews (1, fig. 82) that hold the two eccentric pivots (2) in each end of the teletypewriter frame.
- (14) Hold the platen assembly and pull out the eccentric pivots enough to clear the platen frame (41). On the TT-4A/TG, move the platen assembly back enough to clear the pressure-roller control shaft (27, fig. 83) from the ribbon-lifter bell crank (15, fig. 87). On the TT-4B/TG, move the platen assembly back so that the pressure-roller operating shaft (30, fig. 84) clears the ribbon-lifter bell crank (9, fig. 88). The platen-latching arm (6, fig. 82) must also clear the aperture gate (36, fig. 98).
- (15) Remove the platen assembly by moving it toward the selector side frame, permitting the links to disengage from their mating studs.

b. Replacement.

- (1) Replace the platen assembly by reversing the procedures (described in a(12) through (15) above).
- (2) Adjust the platen assembly as described in paragraphs 234 through 246.
- (3) Replace the dust cover as described in paragraph 57b.

63. Removal and Replacement of Carriage

a. Removal.

- (1) Remove the dust cover (par. 57a).
- (2) Remove the paper shaft, paper-shaft bracket, and paper chute (par. 58a).
- (3) Move the carriage to the left margin stop and mark the two teeth on the carriage-rack driving gear (fig. 28) that engage the last tooth on the carriage rack (13, fig. 85).
- (4) Remove the machine screws (1 and 3, fig. 85) and lock washers (2 and 4) that hold the carriage guide rail (17) to the frame.
- (5) Remove the two machine screws (5), fiat washers (7), and lockwashers (6) that hold the bearing cap and the type-selecting arm assembly (fig. 86)

gh (42); remove
re (1, fig. 82)
entric pivots (2)
e teletypewriter
nbly and pull out
enough to clear
1). On the TT-
platen assembly
ar the pressure-
(27, fig. 83) from
ll crank (15, fig.
B/TG, move the
s so that the pres-
g shaft (30, fig.
n-lifter bell crank
aten-latching arm
so clear the aper-
).
assembly by mov-
ector side frame,
iks to disengage
tuds.
assembly by re-
ure (described in
at
assembly as de-
aphs 234 through
cover as described
ment of Carriage
ver (par. 57a).
shaft, paper-shaft
chute (par. 58a).
to the left margin
e two teeth on the
ing gear (fig. 28)
st tooth on the car-
85).
ne screws (1 and 3,
washers (2 and 4)
age guide rail (17)
achine screws (5),
nd lockwashers (6)
aring cap and the
assembly (fig. 86)

to the carriage frame; remove the bearing cap and type-selecting arm assembly.

- (6) Remove the two machine screws (8, fig. 85) and lock washers (9) that hold the carriage rear-support bracket (10) to the carriage frame; slide the bracket and square-shaft sliding gear toward the right-hand end of the square shaft and remove the bracket.
- (7) Lift the carriage forward and upward to remove it from the frame.

b. Replacement.

- (1) Position the carriage on the frame so that the two marked teeth of the carriage-rack driving gear are meshed with the last tooth on the left end of the carriage rack.

Note. Be sure the bar of the pressure-roller assembly (fig. 47) is engaged in the groove of the slide bearing of the ribbon-lifter assembly.

- (2) Align the carriage guide rail (17) with the two holes in the frame; secure the rail with machine screws (1 and 3) and lock washers (2 and 4).
- (3) Turn the square-shaft sliding gear bearing (fig. 198) until the flat part of the bearing is adjacent to the function-shaft driven gear. Carefully insert the fingers of the carriage rear-support bracket (10, fig. 85) into the groove in the sliding gear. *Be sure the bracket fingers are aligned with the two flat surfaces in the groove.* Slide the assembled gear and bracket along the square shaft until the holes in the bracket are aligned with the holes in the carriage frame (27). Fasten the bracket to the frame with two machine screws (8) and lock washers (9).
- (4) Press the blank keylever and turn the motor manually until the square shaft stops turning. Install the type-selecting arm assembly so that the type-selecting arm is aligned with the last notch in the right-hand side of the guide plate.
- (5) Position the bearing cap on the carriage frame; secure with the two ma-

chine screws (5), lockwashers (6), and flat washers (7).

- (6) Adjust the carriage (par. 206, 207, and 208).
- (7) Replace the paper shaft, paper-shaft bracket, and paper chute (par. 58b).
- (8) Replace the dust cover (par. 57b).

64. Removal and Replacement of Line Terminal Board

a. Removal.

- (1) Remove the dust cover (par. 57a).
- (2) Remove the machine screw (1, fig. 125), lockwasher (2), and the knurled nut (5) that hold the terminal board (20) to the teletypewriter frame; remove the terminal board.
- (3) Remove the plain hexagonal nut (4) and lockwasher (3) from the set screw (6).
- (4) Remove the five plain hexagonal nuts (7 and 9) and lock washers (8 and 11) that hold the electrical leads to the two shorting bars (15) and three of the five binding posts (19); remove the leads and tag them to facilitate reassembly.

b. Replacement.

- (1) Replace the line terminal board by reversing the procedures described in a(2) through (4) above.
- (2) Replace the dust cover (par. 57b).

65. Removal and Replacement of Instrument Panel

a. Removal.

- (1) Remove the dust cover (paragraph 57a).
- (2) Pull the assembled keyboard plug cover and plug (65 and 66, fig. 80) from the receptacle connector (14, fig. 79).
- (3) Remove the line terminal board (par. 64a).
- (4) Remove the mounting base (par. 59a).
- (5) Carefully turn the machine onto the selector side.
- (6) Remove the four machine screws (1, fig. 124) and lock washers (2) that hold the filter box cover (3) on the filter box (62); remove the filter box cover.

- (7) On the TT-4A/TG, remove the electrical leads of the keyboard cable (73, fig. 80) from the filter box; tag the leads to facilitate reassembly.
 - (8) On the TT-4B/TG, remove the electrical leads of the instrument-panel cable (78, fig. 80) from the filter box; tag the leads to facilitate reassembly.
 - (9) Turn the machine right side up.
 - (10) On the TT-4A/TG, remove the two self-locking hexagonal nuts (1, fig. 121) and lockwashers (2) that hold the motor-stop contact shield (3) on the mounting studs (7); remove the motor-stop contact shield and lockwashers (4).
 - (11) On the TT-4A/TG, remove all electrical leads of the selector-magnet and motor-stop cable (63, fig. 80); tag the leads to facilitate reassembly.
 - (12) On the TT-4B/TG, remove the two machine screws (1, fig. 122) and lockwashers (2) that hold the motor-stop-switch cover (3) to the cover mounting studs (6); remove the motor-stop-switch cover.
 - (13) On the TT-4B/TG, remove all electrical leads of the instrument-panel cable (78, fig. 80) from the motor stop and selector magnet; tag the leads to facilitate reassembly.
 - (14) On the TT-4A/TG, remove the machine screw (3, fig. 80) and lockwasher (4) that hold the cable clamp (5) to the frame. Remove the machine screw (6) and lockwasher (7) that hold the grounding lug of the keyboard cable (73) to the frame. Remove the two machine screws (8) and lockwashers (9) that hold the grounding lug of the selector-magnet and motor-stop cable (63) and the armature-dial-shaft bracket (29) to the frame.
 - (15) On the TT-4B/TG, remove the two machine screws (8) and lockwashers (9) that hold the grounding lug of the instrument-panel cable (78) and the armature-dial-shaft bracket (29) to the frame. Remove the three machine screws (10, 13, and 16) and lockwashers (11, 14, and 17) that hold the cable clamps (12, 15, and 18) to the frame.
 - (16) Remove the two machine screws (19 and 21), lockwashers (20 and 22), machine screw (23), lockwasher (24), self-locking hexagonal nut (25), and lockwasher (26) that hold the instrument panel to the frame; remove the instrument panel.
- b. Replacement.*
- (1) Replace the instrument panel by reversing the procedures (described in a(6) through (16) above).
 - (2) Replace the mounting base (par. 59b).
 - (3) Replace the line terminal board (par. 64a(1)).
 - (4) Insert the assembled keyboard plug cover and plug (65 and 66, fig. 80) into the receptacle connector (14, fig. 79).
 - (5) Replace the mounting base (par. 59b).

Section VI. DISASSEMBLY AND REASSEMBLY OF TELETYPEWRITER COMPONENTS

This section describes disassembly and reassembly procedures for Teletypewriters TT-4A/TG and TT-4B/TG. These procedures are used in conjunction with the removal and replacement procedures described in paragraphs 56 through 65.

66. General Disassembly Procedure

a. Preparation for Disassembly. Before starting to disassemble the teletypewriter proceed as follows:

- (1) Arrange a clean place on a bench or table to work. Be certain that dust or dirt will not fall or be blown into the

mechanism while it is disassembled.

- (2) Obtain several small, clean containers to store removed parts.
- (3) Arrange the necessary tools and materials so that they will be readily accessible during the progress of the repair work.

b. Disassembly Procedure.

- (1) Disconnect the power and signal line cables from the teletypewriter.
- (2) Remove the dust cover (par. 57a).
- (3) Remove the inking ribbon and paper from the teletypewriter.
- (4) Disassemble the various parts and as-

semblies; use the correct tool for each specific operation. Do not disassemble the teletypewriter or its assemblies beyond the point necessary to thoroughly inspect and clean the mechanism, and to repair and replace any parts.

- (5) When small parts are disassembled, place them in a container and mark them to identify their origin. Vary the sequence of disassembly to meet any particular situation. Use the procedure that will require the least amount of time without sacrificing quality.

67. General Reassembly Procedures

Reassemble all parts, subassemblies, and units in accordance with the following provisions:

a. Replace all worn or broken parts that cause malfunctioning of the teletypewriter and adjust them according to the directions in the appropriate paragraphs. While the equipment is disassembled for checking and repair, replace any parts that are likely to cause trouble before the next scheduled overhaul of the machine.

b. Tighten all screws, nuts, and bolts carefully, but not excessively. Threaded holes in aluminum or magnesium alloy castings and will be stripped if too much force is used. When installing screws in aluminum or magnesium alloy castings, treat them with Anti-seize Compound (CE-52-2724.5000.080) before installation.

c. Be careful to install the correct springs in the friction clutches. Some springs are similar in appearance, but they are not identical. Installation of incorrect springs can result in faulty operation and cause premature failure of the clutches.

d. Be sure to install tapered pins so that the taper of the hole in the shaft and the hole in the part being pinned is matched and that the tapered pin is inserted in the proper direction. Before driving the pins, place a support under the parts to prevent bending or distortion.

e. If a set screw is used to secure a part to a shaft, remove the set screw from the part and sight down the tapped hole in the part to make sure the hole is in line with the flat on

the shaft. If two set screws are used to secure a part to the shaft, be sure *each* tapped hole is aligned with a flat on the shaft.

f. Some bent and distorted parts may be restored to shape and re-used, if no cracks result from the straightening process and if the hardened surfaces are not softened by the repairs.

g. If the locking edges of lock washers are rounded, install new lockwashers.

h. Replace screws or nuts that have damaged heads or threads.

68. Disassembly and Reassembly of Transmitter Contact Assembly (fig. 75)

a. Disassembly.

- (1) Remove the two machine screws (1) and lockwashers (2) that hold the contact cover (3) to the keyboard frame; remove the contact cover and two lockwashers (4).
- (2) Unhook the end of the contact-bail spring (7) from the spring post on the contact plate (17) and from the hole in the contact bail (11).
- (3) Remove the machine screw (8), lockwasher (9), and the two electrical terminal lugs from the side of the contact plate (17).
- (4) Remove the retainer ring (10) that holds the contact bail (11) to the spring post on the keyboard frame; remove the contact bail.
- (5) Remove the two machine screws (12) and lockwashers (13), and unsolder the two contact wires (16) that hold the two contact terminals (14) to the contact plate (17); remove the two contact terminals.
- (6) Remove the two contacts (15) from the contact plate (17).
- (7) Remove the two machine screws (5) and lockwashers (6) that hold the contact plate (17) to the keyboard frame; remove the contact plate (17).

b. Reassembly.

- (1) Reassemble the contacts as indicated in figure 75; the sequence for assembling the parts is the reverse of disassembly, except that the two contact terminals (14) should be inserted in

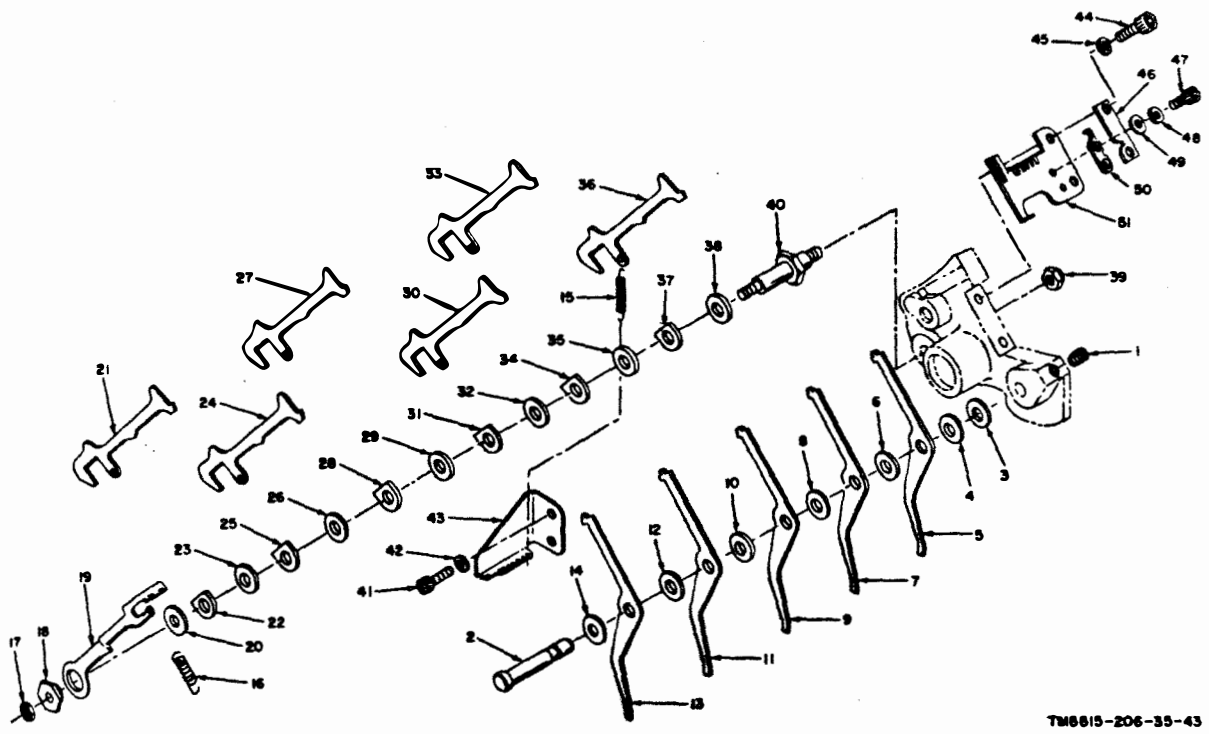

TM6615-206-35-43

- | | | |
|--|---------------------------------------|--|
| 1. Setscrew, 10210 | 18. Eccentric bearing, 51557 | 36. Selector lever, 51598A |
| 2. Sensing-lever pivot stud, 51562 | 19. Sensing-lever-locking bail, 51567 | 37. Bearing, 51644A |
| 3. Laminated washer, 53526 | 20. Spacing collar, 51555 | 38. Selector-lever spacer, 50147* |
| 4. Spacer, 50147 | 21. Selector lever, 51598A | 39. Self-locking hexagonal nut, 10501 |
| 5. Sensing lever, 51573A | 22. Bearing, 51644A | 40. Selector-lever pivot post, 51561 |
| 6. Spacer, 50147 | 23. Flat washer, 50147 | 41. Machine screw, 10003 |
| 7. Sensing lever, 51573A | 24. Selector lever, 51598A | 42. Lockwasher, 10429 |
| 8. Spacer, 50147 | 25. Bearing, 51644A | 43. Selector-lever-spring bracket, 51559 |
| 9. Sensing lever, 51573A | 26. Flat washer, 50147 | 44. Machine screw, 10008 |
| 10. Spacer, 50147 | 27. Selector lever, 51598A | 45. Lockwasher, 10430 |
| 11. Sensing lever, 51573A | 28. Bearing, 51644A | 46. Adjusting plate, 55869* |
| 12. Spacer, 50147 | 29. Flat washer, 50147 | 47. Machine screw, 10001 |
| 13. Sensing lever, 51573A | 30. Selector lever, 51598A | 48. Lockwasher, 10429 |
| 14. Spacer, 50147 | 31. Bearing, 51644A | 49. Flat washer, 10459 |
| 15. Selector-lever spring, 50902 | 32. Flat washer, 50147 | 50. Stop-selector-lever latch, 55870 |
| 16. Sensing-lever-locking bail spring, 51574 | 33. Selector lever, 51598A | 51. Selector-lever comb, 51558 |
| 17. Self-locking hexagonal nut, 10500 | 34. Bearing, 51644A | |
| | 35. Flat washer, 50147 | |

* Used on TT-4B/TG only.

Figure 76. Keyboard-transmitter sensing and selector lever assembly, exploded view.

- (8) Remove the self-locking hexagonal nut (39) and remove the selector-lever pivot post (40).
 - (9) Remove the two machine screws (41) and lockwashers (42). Remove the selector-lever-spring bracket (43).
- b. Reassembly.**
- (1) Reassemble the keyboard-transmitter sensing and selector lever assembly as indicated in figure 76; the sequence for assembling the parts is the reverse of the disassembly sequence.
- Note.* All bearings (22, 25, 28, 31, 34, and 37) must have chamfered face in same direction.
- (2) Replace the keyboard-transmitter on the teletypewriter (par. 61b).
 - (3) Adjust the keyboard-transmitter sensing and selecting lever assembly (par. 141, 142, 143, 144, and 147).
- 70. Disassembly and Reassembly of Keylevers and Code Bars (fig. 77)**
- a. Disassembly.**
- (1) Remove the keyboard-transmitter from the teletypewriter (par. 61a).

- (2) On the TT-4A/TG, remove the two retainer rings (7 and 8) that hold the space-bar-arm shaft (9) in the front keylever guide (37). Remove the space-bar-arm shaft that holds the space-bar-arm (11) to the front keylever guide; remove the space-bar arm.
- (3) On the TT-4B/TG, remove the two retainer rings (7 and 8) that hold the space-bar-arm shaft (9) in the front keylever guide (37). Remove the space-bar-arm shaft that holds the space-bar arm (12) to the front keylever guide; remove the space-bar spring (10) and the space-bar arm.
- (4) On the TT-4B/TG, remove the three machine screws (13) and lockwashers (14) that hold the keylever-locking bar (15) to the keylever mounting bracket (26); remove the keylever-locking bar.
- (5) Remove the 31 keylever springs (16) from the keylevers and from the keylever mounting bracket (26).
- (6) Remove the space-bar-lever spring (17) from the space-bar lever (23) and from the keylever mounting bracket (26).
- (7) Remove the assembled keytops (18) and short keylevers (19), keytops and medium keylevers (20), and keytops and long keylevers (21, TT-4A/TG or 22, TT-4B/TG). If a keytop of the TT-4A/TG is damaged remove the damaged keytop and replace it with the appropriate keytop ((a) through (c) below). If a keytop of the TT-

4B/TG is damaged, replace the keylever and keytop assembly.

- (a) Short keylevers and keytop chart.
- (b) Medium keylevers and keytop chart.

Part reference designation		Keytop symbols
TT-4A/TG round keytop	TT-4B/TG square keytop with keylever	
50787	54044A	A
50788	54045A	S BELL
50789	54046A	D \$
50790	54047A	F !
50791	54048A	G &
50792	54049A	H STOP
50793	54050A	J '
50794	54051A	K (
50795	54052A	L)
50796	54053A	CAR RET

- (c) Long keylevers and keytop chart.

Part reference designation		Keytop symbols
TT-4A/TG round keytop	TT-4B/TG square keytop with keylever	
50797	57805A	FIGS
50798	60218A	Z "
50799	57807A	X /
50800	57808A	C :
50801	60219A	V ;
50802	57810A	B ?
50803	57811A	N ,
50804	57812A	M .
50805	57813A	LTRS
50806	57814A	LINE FEED
50807	60220A	

- (8) Remove the space-bar lever (23).
- (9) On the TT-4A/TG, unsolder the leads to the filter (8, fig. 79). Remove the machine screw (3), lockwasher (4), and self-locking hexagonal nut (5) that hold the filter (8) to the keyboard frame (37); remove the filter and the lockwasher (10).
- (10) On the TT-4B/TG, unsolder the leads to the filter (9, fig. 79). Remove the two machine screws (3 and 6) and lockwashers (4 and 7) that hold the filter (9) to the keyboard frame (37) and to the keylever mounting bracket (26, fig. 77); remove the filter and the lockwasher (10, fig. 79).
- (11) Remove the four machine screws (24, fig. 77) and lockwashers (25) that hold

Part reference designation		Keytop symbols
TT-4A/TG round keytop	TT-4B/TG square keytop with keylever	
50777	54033A	Q 1
50778	54034A	W 2
50779	54035A	E 2
50780	54036A	R 4
50781	54037A	T 5
50782	54038A	Y 6
50783	54039A	U 7
50784	54040A	I 8
50785	54041A	O 9
50786	54042A	P 9

place the key-
ly.
ch.
op chart.

Keypop
symbols

A
S BELL
D \$
F !
G &
H STOP
J '
K (
L)
CAR RET

chart.

Keypop
symbols

FIGS
Z "
X /
B ?
N ,
M .
LTRS
LINE FEED

er (23).
der the leads
Remove the
washer (4),
nal nut (5)
to the key-
ve the filter

der the leads
Remove the
and 6) and
at hold the
frame (37)
ting bracket
ilter and the

screws (24,
5) at hold

the keylever mounting bracket (26) to the keyboard frame; remove the keylever mounting bracket.

- (12) Remove the machine screw (27) and lockwasher (28) that hold the assembled switch-box cover (19, fig. 79) to the front keylever guide (37, fig. 77).
- (13) Lift up the assembled switch-box cover to remove the machine screw (29) and lockwasher (30); remove the machine screw and lockwasher that hold the loop of the cable (15, fig. 79).
- (14) Remove the two machine screws (31, fig. 77) and lockwashers (32) that hold the cable clamps (33) to the front keylever guide (37); remove the cable clamps from the cable (15, fig. 79).
- (15) Remove the universal-bar return spring (34, fig. 77) from the spring post on the front keylever guide (37) and from the spring post on the universal bar (47).
- (16) Remove the machine screw (35) and lockwasher (36) that hold the front keylever guide (37) to the code-bar guide studs (41); remove the front keylever guide.
- (17) Remove the two machine screws (38) and lockwashers (39) that hold the two code-bar guide studs (41); remove the code-bar guide studs.
- (18) Remove the middle keylever guide (40) from the code-bar guide studs (41).
- (19) Remove the two code-bar guide studs (41) from the five code bars (42, 43, 44, 45, and 46) and the universal bar (47).

b. Reassembly.

- (1) Reassemble the keylevers and code bars by reversing the procedures outlined in *a*(19) through (2) above.
- (2) Replace the keyboard-transmitter on the teletypewriter as described in paragraph 61*b*.
- (3) Adjust the keylever-locking bar and the universal bar as described in paragraphs 136 and 139.

71. Disassembly and Reassembly of Keyboard-Transmitter-Camshaft Locking Mechanism (fig. 78)

a. Disassembly.

- (1) Remove the keyboard-transmitter (par. 61*a*).
- (2) Unhook the locking-lever-latch spring (1) from the locking-lever latch (9 or 12) and from the spring post on the keyboard frame.
- (3) Remove the set screw (2) that holds the locking-lever-latch stud assembly (5) through (12) in the keyboard frame; remove the locking-lever-latch stud assembly.
- (4) Unhook the repeat-blocking-lever spring (3) from the repeat-blocking lever (6) and from the spring post on the locking-lever latch (9 or 12).
- (5) Remove the retainer ring (4) from the locking-lever-latch stud (5); remove the locking-lever-latch stud and repeat-blocking lever (6) from the locking-lever latch (9 or 12).
- (6) Remove the plain hexagonal nut (7) and universal-bar adjusting screw (8) from the locking-lever latch (9 or 12). On the TT-4B/TG, remove the plain hexagonal nut (10) and setscrew (11) from the locking-lever latch (12).
- (7) Remove the repeat-lever pivot stud (13), repeat lever (14), and flat washer (15) from the keyboard frame.

b. Reassembly.

- (1) Reassemble the keyboard-transmitter-camshaft locking mechanism as indicated in figure 78; the sequence for assembling the parts is the reverse of disassembly.
- (2) Replace the keyboard-transmitter (par. 61*b*).
- (3) Adjust the keyboard-transmitter-camshaft locking mechanism (par. 138 through 140).

72. Disassembly and Reassembly of Transmitter Camshaft and Filter (fig. 79)

a. Disassembly.

- (1) Remove the keyboard-transmitter from the teletypewriter (par. 61*a*).

Figure 77. Keylevers and code bars, exploded view.

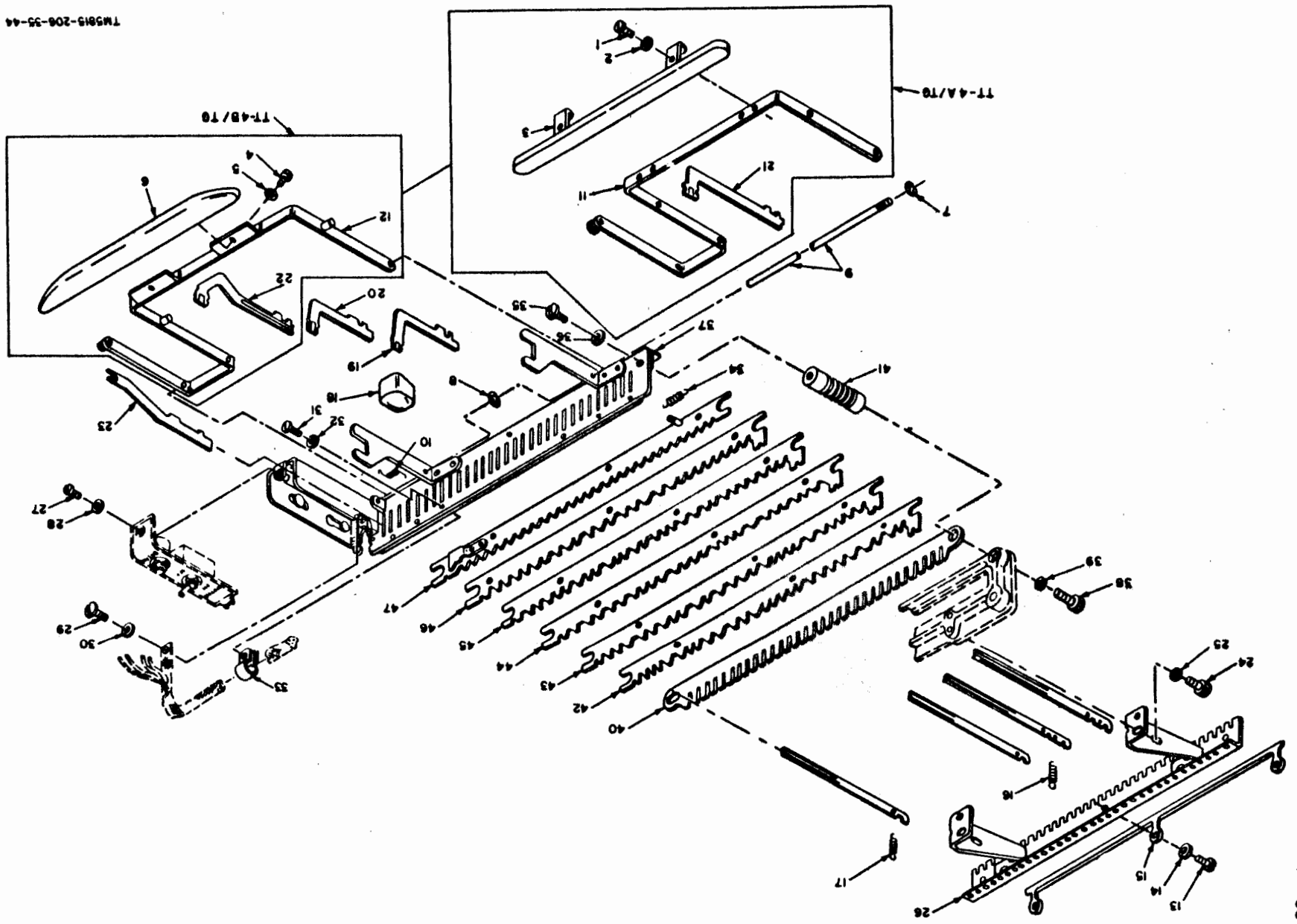

- | | | |
|---|--|---|
| 1. Machine screw, 10002 | 17. Space-bar-lever spring, 50942 ^a , 53974 ^b | 33. Cable clamp, 20729 |
| 2. Lockwasher, 10429 | 18. Keytop (see keytop chart) | 34. Universal-bar return spring, 51136 |
| 3. Spacebar, 50845 | 19. Short keylever, 52582 ^a , 55917 ^b | 35. Machine screw, 50207 ^a , 10024 ^b |
| 4. Machine screw, 10001 | 20. Medium keylever, 52583 ^a , 55918 ^b | 36. Lockwasher, 10405 |
| 5. Lockwasher, 10429 | 21. Long keylever, 52584 | 37. Front keylever guide, 50692A ^a , 57791A ^b |
| 6. Spacebar, 53944A | 22. Long keylever, 57815 | 38. Machine screw, 10017 |
| 7. Retainer ring, 51099 ^a , 10969 ^b | 23. Spacebar lever, 55916 | 39. Lockwasher, 10405 ^a , 10431 ^b |
| 8. Retainer ring, 51099 ^a , 10969 ^b | 24. Machine screw, 10015 | 40. Middle keylever guide, 52915 |
| 9. Space-bar-arm shaft, 50808 ^a , 55862 ^b | 25. Lockwasher, 10405 ^a , 10431 ^b | 41. Code-bar guide stud, 51560 |
| 10. Space-bar spring, 56688 ^b | 26. Keylever mounting bracket, 52918A ^a , 57279A ^b | 42. Code bar, 53299 |
| 11. Space-bar arm, 50687A | 27. Machine screw, 10308 | 43. Code bar, 53298 |
| 12. Space-bar arm, 57793A | 28. Lockwasher, 10403 | 44. Code bar, 53297 |
| 13. Machine screw, 10304 ^b | 29. Machine screw, 50207 ^a , 10308 ^b | 45. Code bar, 53296 |
| 14. Lockwasher, 10429 ^b | 30. Lockwasher, 10403 | 46. Code bar, 53295 |
| 15. Keylever-locking bar, 53210 ^b | 31. Machine screw, 10308 | 47. Universal bar, 51134A |
| 16. Keylever spring, 50941 | 32. Lockwasher, 10403 | |

^a Used on TT-4A/TG.

^b Used on TT-4B/TG.

Figure 77—Continued

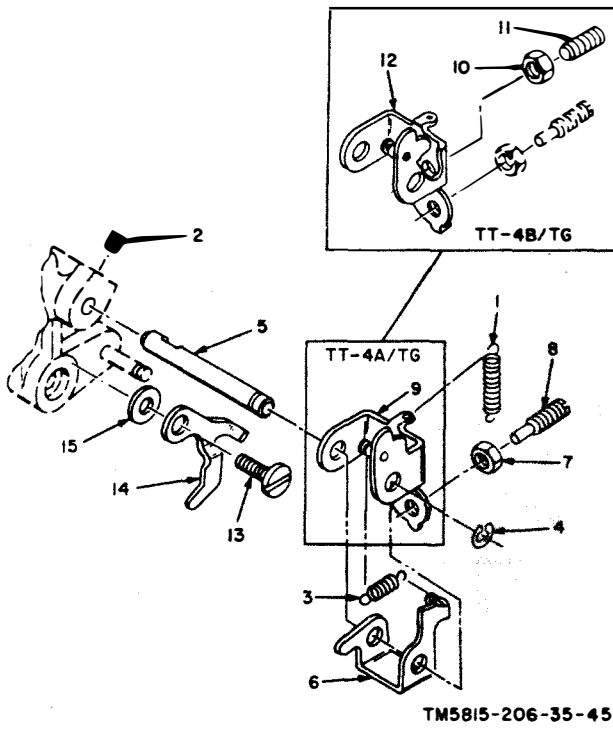

TM5815-206-35-45

1. Locking-lever-latch spring, 51544
2. Setscrew, 10210
3. Repeat-blocking-lever spring, 50944
4. Retainer ring, 10949
5. Locking-lever-latch stud, 51564
6. Repeat-blocking lever, 59477
7. Plain hexagonal nut, 10507
8. Universal-bar adjusting screw, 50658
9. Locking-lever latch, 51570A
10. Plain hexagonal nut, 10507
11. Setscrew, 10233
12. Locking-lever latch, 59475A
13. Repeat-lever pivot stud, 51568
14. Repeat lever, 50615
15. Flat washer, 50414

Figure 78. Keyboard-transmitter-camshaft locking mechanism, exploded view.

- (2) Remove the keylevers and code bars (par. 70a).
- (3) Remove the two machine screws (11) and lockwashers (12) that hold the receptacle connector (14), jumper wire (13), and grounding lug of the cable (15) to the keyboard frame; remove the jumper wire and the plug.
- (4) Unsolder the electrical leads of the cable (15) from the assembled BREAK switch (17) and MOTOR switch (21); remove the cable.
- (5) Remove the plain hexagonal nut (16) that holds the BREAK switch (17) to the switch-box cover (19); remove the BREAK switch.
- (6) Remove the plain hexagonal nut (18) that holds the switch-box cover (19) to the MOTOR switch (21); remove the switch-box cover and the plain hexagonal nut (20).
- (7) Remove the two setscrews (22) that hold the clutch fork (23) to the transmitter camshaft (25); remove the clutch fork and spacer (24) from the transmitter camshaft. Remove the transmitter camshaft (25) from the keyboard frame (37)..
- (8) Remove the two machine screws (26), lockwashers (27), and flat washers (28) that hold the ball bearing (29), collar (30), and ball bearing (31) in the keyboard frame (37); remove the two ball bearings and collar.

- (9) Remove the cam-stop-lever spring (32) from the cam-stop lever (34).
- (10) Remove the retainer ring (33) that holds the cam-stop lever (34) to the cam-stop-lever post (36); remove the cam-stop lever.
- (11) Remove the self-locking hexagonal nut (35) that holds the cam-stop-lever post (36) in the keyboard frame (37); remove the cam-stop-lever post.

b. Reassembly.

- (1) Reassemble the transmitter camshaft as indicated in figure 79; the sequence for assembling the parts is the reverse of the disassembly sequence.
- (2) Replace the keylevers and code bars (par. 70b).
- (3) Replace the keyboard-transmitter on the teletypewriter (par. 61b).
- (4) Adjust the transmitter camshaft and filter (par. 137).

73. Disassembly and Reassembly of Instrument Panel (fig. 80)

a. Disassembly.

- (1) Remove the instrument panel (par. 65a).
- (2) Remove the two setscrews (27) that hold the armature worm (28) on the armature-dial shaft (48); remove the armature worm and the armature-dial-shaft bracket (29).
- (3) Remove the armature spring (30) from the armature-spring arm (33) and from the selector-magnet armature (8, fig. 91).
- (4) Remove the machine screw (31, fig. 80) and clamp nut (32) that hold the armature-spring arm (33) to the armature-worm shaft (36); remove the armature-spring arm.
- (5) Remove the two setscrews (34) that hold the armature-worm arm (35) to the armature-worm shaft (36); remove the armature-worm arm. Remove the armature-worm shaft from the frame.
- (6) Remove the two setscrews (37) that hold the rangefinder cam (38) to the rangefinder shaft (43); remove the rangefinder cam.
- (7) Remove the two setscrews (39) that hold the collar (40) to the rangefinder shaft (43); remove the collar.
- (8) Remove the two setscrews (41) that hold the rangefinder gear (42) to the rangefinder shaft (43); remove the rangefinder gear.
- (9) Remove the machine screw (44) and dial-clamp nut (45) that hold the dial clamp (46) to the panel (103); remove the dial clamp.
- (10) Remove the taper pin (47) from the armature-dial shaft (48) in the panel (103); remove the armature-dial shaft.
- (11) Remove the two setscrews (49) that hold the rangefinder gear (50) to the rangefinder dial (54); remove the rangefinder gear.
- (12) Remove the machine screw (51) and dial-clamp nut (52) that hold the dial clamp (53) to the panel (103); remove the dial clamp and the rangefinder dial (54).
- (13) On the TT-4A/TG, remove the plain hexagonal nut (55), lock washers (56 and 57), and machine screw (58) that hold the grounding lug of the selector-magnet and motor-stop cable (63).
- (14) On the TT-4A/TG, unsolder the electrical leads of the selector-magnet and motor-stop cable (63); tag the leads to facilitate reassembly.
- (15) Remove the drive screw (64) that holds the plug (65) in the keyboard plug cover (66); remove the plug and unsolder the electrical leads of the keyboard cable (73) or instrument-panel cable (78). Tag the leads to facilitate reassembly.
- (16) On the TT-4A/TG, unsolder the electrical leads of the keyboard cable (73); tag the leads to facilitate reassembly.
- (17) On the TT-4B/TG, unsolder the leads of the instrument-panel cable (78); tag the leads to facilitate reassembly.
- (18) Remove the plain hexagonal nut (79) that holds the switch (80) to the panel (103); remove the switch. Do not remove the electrical leads from

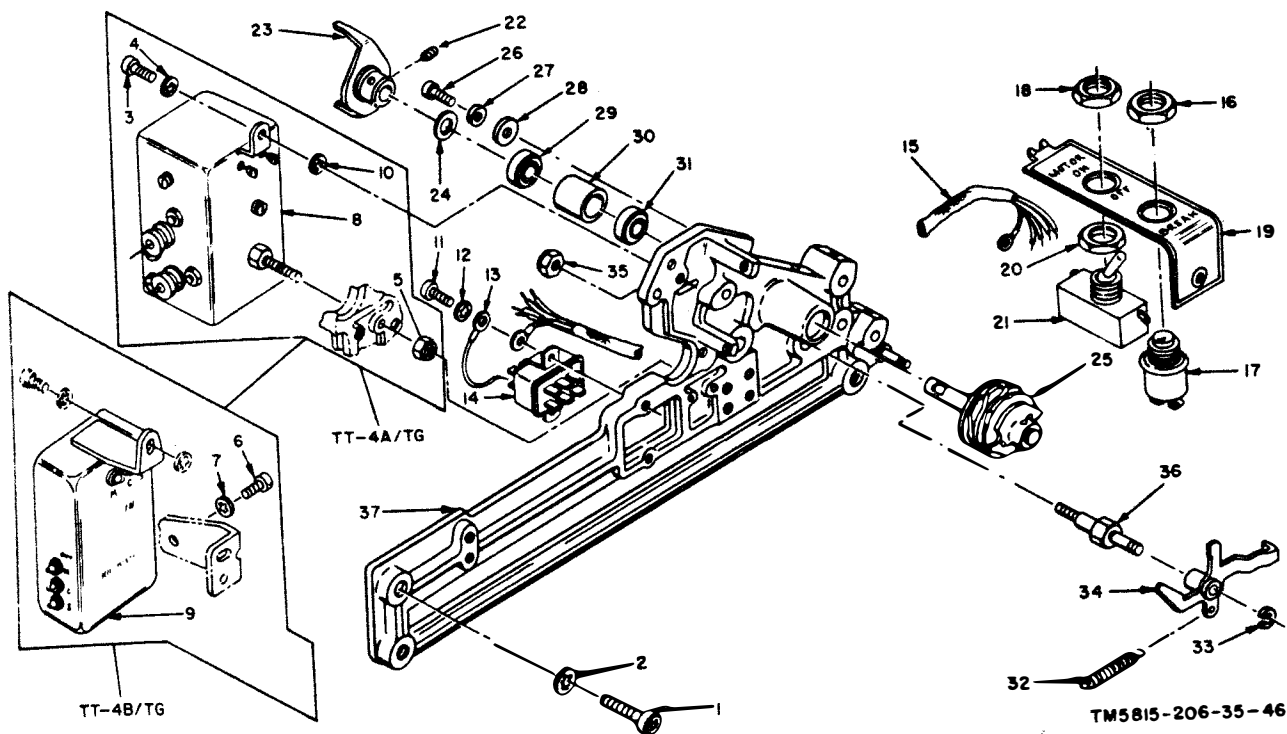

1. Machine screw, 10027
2. Lockwasher, 10400
3. Machine screw, 10001
4. Lockwasher, 10403
5. Self-locking hexagonal nut, 10500
6. Machine screw, 10301
7. Lockwasher, 10403
8. Filter Z2, 51622A
9. Filter Z2, 54576
10. Lockwasher, 10403
11. Machine screw, 10003
12. Lockwasher, 10064
13. Jumper wire, 51665A

14. Receptacle connector J2, 20400*, 20259^b
15. Cable, 51624A
16. Plain hexagonal nut
17. BREAK switch S3, 20101 (includes item 16)
18. Plain hexagonal nut
19. Switch-box cover, 50703
20. Plain hexagonal nut
21. MOTOR switch S2, 20102 (includes items 18 and 20)
22. Setscrew, 10209
23. Clutch fork, 50484A
24. Spacer, 51552

25. Transmitter camshaft, 51545A
26. Machine screw, 10003
27. Lockwasher, 10429
28. Flat washer, 10458
29. Ball bearing, 10753
30. Collar, 51599
31. Ball bearing, 10753
32. Cam-stop-lever spring, 51575
33. Retainer ring, 10949
34. Cam-stop lever, 51549A
35. Self-locking hexagonal nut, 10501
36. Cam-stop-lever post, 51563
37. Keyboard frame, 51441A*, 60510A^b

* Used on TT-4A/TG.

^b Used on TT-4B/TG.

Figure 79. Transmitter camshaft and filter, exploded view.

- the switch to the copy-light connector (81) unless necessary.
- (19) Remove the setscrew (82) that holds the knob (83) on the shaft of the resistor (86); remove the knob.
 - (20) Remove the plain hexagonal nut (84) and lockwasher (85) that hold the resistor (86) to the panel (103); remove the resistor.
 - (21) Remove the fuse cap (87) that holds the fuse (88) in the fuse holder (92); remove the fuse.
 - (22) On the TT-4A/TG, remove the plain hexagonal nut (89) that holds the fuse holder (92) to the panel (103);

- remove the fuse holder and the rubber washer (91).
- (23) On the TT-4B/TG, remove the plain hexagonal nut (89) and lockwasher (90) that hold the fuse holder (92) to the panel (103); remove the fuse holder and the rubber washer (91).
 - (24) Remove the fuse cap (93) that holds the fuse (94) in the fuse holder (98); remove the fuse.
 - (25) On the TT-4A/TG, remove the plain hexagonal nut (95) that holds the fuse holder (98) on the panel (103); remove the fuse holder and the rubber washer (97).

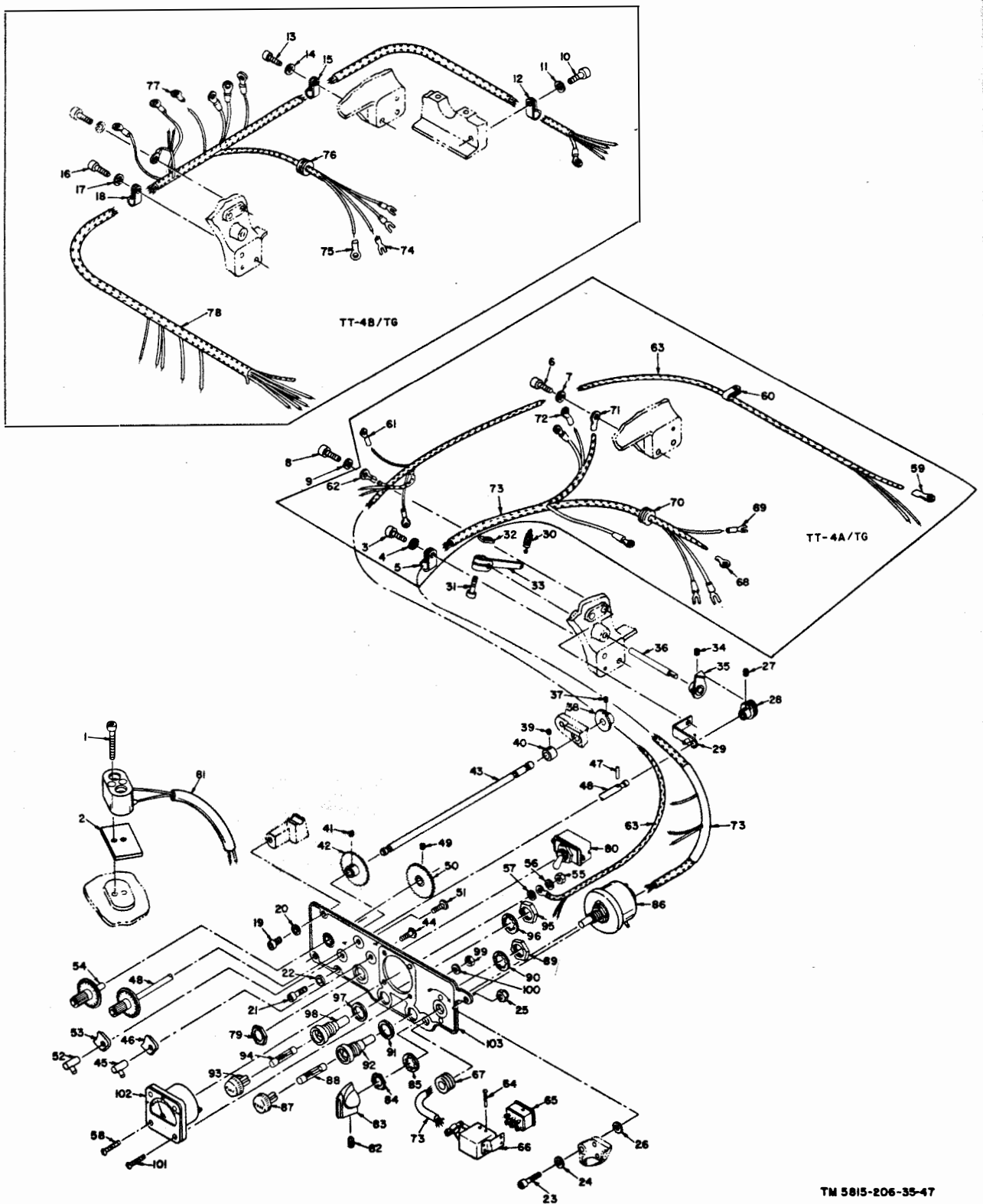

TM 5815-206-35-47

1. Machine screw, 10012
2. Insulator, 51656
3. Machine screw, 10026-01
4. Lockwasher, 10405

5. Cable clamp, 51084
6. Machine screw, 10026-01
7. Lockwasher, 10405
8. Machine screw, 10009

9. Lockwasher, 10404
10. Machine screw, 10017-01
11. Lockwasher, 10405
12. Cable clamp, 51044

Figure 80. Instrument panel, exploded view.

13. Machine screw, 10026-01
14. Lockwasher, 10405
15. Cable clamp, 51044
16. Machine screw, 10026-01
17. Lockwasher, 10405
18. Cable clamp, 51044
19. Machine screw, 10008-01
20. Lockwasher, 10404
21. Machine screw, 10008-01
22. Lockwasher, 10404
23. Machine screw, 10010-01
24. Lockwasher, 10404
25. Self-locking hexagonal nut, 10501
26. Lockwasher, 10404
27. Setscrew, 10201
28. Armature worm, 50992
29. Armature-dial-shaft bracket, 50984A
30. Armature spring, 50908
31. Machine screw, 10006
32. Clamp nut, 50174
33. Armature-spring arm, 50017
34. Setscrew, 10201
35. Armature-worm arm, 50888
36. Armature-worm shaft, 50900
37. Setscrew, 10201
38. Rangefinder cam, 50317
39. Setscrew, 10201
40. Collar, 50391
41. Setscrew, 10201
42. Rangefinder gear, 50312A
43. Rangefinder shaft, 50328
44. Machine screw, 10307
45. Dial-clamp nut, 50895A
46. Dial clamp, 51609
47. Taper pin, 10855

48. Armature-dial shaft, 51605A
49. Setscrew, 10201
50. Rangefinder gear, 50312A
51. Machine screw, 10307
52. Dial-clamp nut, 50895A
53. Dial clamp, 51609
54. Rangefinder dial, 51607A
55. Plain hexagonal nut
56. Lockwasher, 10408
57. Lockwasher, 10408*
58. Machine screw
59. Terminal, 20708
60. Cable clamp, 51083
61. Terminal, 20707
62. Terminal, 20710
63. Selector-magnet and motor-stop cable, 51076A (includes items 59, 60, 61, and 62)
64. Drive screw
65. Plug J2
66. Keyboard plug cover, 20409*, 20413* (includes items 64 and 65)
67. Grommet, 20726
68. Terminal, 20708
69. Terminal, 20709
70. Grommet, 20726
71. Terminal, 20710
72. Terminal, 20707
73. Keyboard cable, 51705A (includes items 68, 69, 70, 71, and 72)
74. Terminal, 20706
75. Terminal, 20708
76. Grommet, 20726
77. Terminal, 20707

78. Instrument-panel cable, 60247A, (includes items 74, 75, 76, and 77)
79. Plain hexagonal nut
80. Switch S1
81. Copy-light connector, 51379A (includes items 79 and 80)
82. Setscrew
83. Knob, 20704 (includes item 82)
84. Plain hexagonal nut
85. Lockwasher
86. Resistor R2, 20008 (includes items 84 and 85)
87. Fuse cap, 20457*, 20460*
88. Fuse F2 (½ amp), 20451
89. Plain hexagonal nut
90. Lockwasher
91. Rubber washer
92. Fuse holder, XF1, 20452* (includes items 87, 89, and 91), 20458* (includes items 87, 89, 90, and 91)
93. Fuse cap, 20457*, 20460*
94. Fuse F1 (1.6 amp), 20455
95. Plain hexagonal nut
96. Lockwasher
97. Rubber washer
98. Fuse holder XF2, 20452* (includes items 93, 95, and 97), 20458* (includes items 93, 95, 96, and 97)
99. Plain hexagonal nut
100. Lockwasher, 10408
101. Machine screw
102. Milliammeter M1, 20576*, 20577* (includes items 55, 58, 99, and 101)
103. Panel, 50340A

* Used on TT-4A/TG.

* Used on TT-4B/TG.

Figure 80—Continued

- (26) On the TT-4B/TG, remove the plain hexagonal nut (95) and lockwasher (96) that hold the fuse holder (98) to the panel (103); remove the fuse holder and the rubber washer (97).
 - (27) On the TT-4A/TG, remove the three plain hexagonal nuts (99), lockwashers (100), and machine screws (101) that hold the milliammeter (102) to the panel (103); remove the milliammeter.
 - (28) On the TT-4B/TG, remove the four plain hexagonal nuts (55 and 99), lockwashers (56 and 100), and machine screws (58 and 101) that hold the milliammeter (102) to the panel (103); remove the milliammeter.
- b. Reassembly.**
- (1) Reassemble the instrument panel as indicated in figure 80; the sequence for reassembling the parts is the reverse of disassembly.
 - (2) Replace the instrument panel (par. 65b).
- 74. Disassembly and Reassembly of Motor (fig. 81)**
- a. Disassembly.**
- (1) Remove the motor (par. 60c).
 - (2) On the TT-4B/TG, remove the three sleeves (6) and lockwashers (7) from the teletypewriter frame.
 - (3) On the TT-4A/TG, remove the machine screw (8) and lockwasher (9) that hold the worm gear (10) on the shaft of the armature (53); remove the worm gear.
 - (4) On the TT-4B/TG, remove the machine screw (8) and lockwasher (9) that hold the worm gear (11) on the shaft of the armature (53); remove the worm gear.
 - (5) Remove the pin (12) that holds the

grease seals (13 and 14) on the armature (53); remove the grease seals.

- (6) Remove the four machine screws (15) and lockwashers (16) that hold the gear end bell (17) on the motor housing (59); remove the gear end bell, thrust pad (18), thrust washer (19), and ball bearing (20).
- (7) Remove the setscrew (21) that holds the governor target (22) to the shaft of the governor base (46); remove the governor target.
- (8) Remove the two machine screws (23) and lockwashers (24) that hold the governor cover (25) to the motor housing (59); remove the governor cover.
- (9) Remove the two setscrews (26) that hold the governor base (46) to the shaft of the armature (53); remove the assembled governor.
- (10) Remove the governor-worm spring (27), governor worm (28), and contact brush (29) from the governor.
- (11) Remove the two contact brushes (30) from the motor housing (59).
- (12) Remove the two brush shields (47) and brush caps (48) that hold the brushes (49) in the motor housing (59); remove the brushes.
- (13) Remove the armature (53) from the motor housing (59).
- (14) Remove the flat washer (50), ball bearing (51), and flat washer (52) from the armature (53).

b. Removal of Motor Capacitors.

- (1) Disassemble the motor (par. *a*(1) or (2), (6), (7), (8), and (11) above).
- (2) Remove the four machine screws (54) and lockwashers (55) that hold the governor end bell (60) to the governor housing; separate the end bell and housing carefully.
- (3) Unsolder the two capacitors (57) from the brush holder in the end bell and remove the machine screws (56) that hold the capacitors in the end bell; remove the capacitors and lockwashers (58).

c. Repair or Replacement of Series-governed Motor Brushes. The contact surfaces of the motor brushes must be curved to fit the com-

mutator surface. Slope the surface of the brush as follows:

- (1) Disassemble the motor (*a* above).
- (2) Wrap a piece of #0000 sandpaper around the armature and under the brush holder, with the abrasive side out. Allow the normal pressure of the brush spring to press the brush against the sandpaper.
- (3) Pull back and forth, following the curvature of the commutator. The last stroke of sandpaper should be in the direction of normal armature rotation.
- (4) Remove the brush from its holder and bevel the edges slightly with sandpaper.
- (5) Wipe the brush with a piece of cloth slightly moistened with cleaning compound.
- (6) Clean the brush holder with a cloth moistened with Cleaning Compound and wrapped around a small screwdriver blade or similarly shaped tool.
- (7) Reinsert the brushes in their holders.
- (8) Reassemble the motor (*e* below).

d. Repair of Motor Commutator. Resurface the commutator as follows:

- (1) Remove the motor (par. 60c).
- (2) Disassemble the motor (*a* above).
- (3) Mount the motor armature in a lathe so that the shaft does not run out of line more than 0.0005 inch. Make a series of light cuts across the commutator with a sharp cutting tool. Do not cut closer than $\frac{1}{8}$ inch from the leads soldered to the commutator. Continue the cuts until enough metal is removed to eliminate the pits, grooves, and rough spots in the surfaces. Do not remove more metal than is necessary.
- (4) Polish the commutator with a strip of fine sandpaper (#000 or #0000) held in flat contact with the commutator as it revolves in the lathe.

Caution: Do not attempt to smooth a rough commutator with sandpaper unless a lathe is available. Do not use emery cloth or carborundum paper. Particles of these abrasives can cause trouble in electrical circuits.

- (5) After resurfacing, do not touch the

commutator with the hands; see that the surfaces of the mica separators are below the surfaces of the copper segments of the commutator.

(6) Reassemble the motor (*e* below).

e. Reassembly. Check the brushes (49). Clean them if they are dirty or glazed; replace them if they are worn, chipped, or saturated with oil (par. 45).

(1) Reassemble the motor as indicated in figure 81; the sequence for assembling the parts is the reverse of the disassembly sequence (*a* and *b* above).

(2) Replace the motor (par. 60*d*).

(3) Adjust the motor (par. 270 through 273).

75. Disassembly and Reassembly of Governor

(fig. 81)

a. Disassembly.

(1) Remove the governor from the motor (par. 74*a*(7) through (9)).

(2) Remove the governor spring (31) from the governor adjustment lever (41) and from the grooved pin (32); remove the grooved pin.

(3) Remove the self-locking hexagonal nut (33), machine screw (34), and lockwasher (35) that hold the contact (36) to the governor base (46); remove the contact.

(4) Remove the plain hexagonal nut (37) and lockwasher (38) that hold the contact (39) to the governor base (46); remove the contact.

(5) Remove the cotter pin (40) that holds the governor adjustment lever (41) to the governor adjustment screw (43); remove the governor adjustment lever.

(6) Remove the cotter pin (42) that holds the governor adjustment screw (43) in the governor base (46); remove the governor adjustment screw and catch the flat washer (44) and speed adjustment gear (45) as they fall.

b. Reassembly. If necessary, clean or burish the contacts before reassembly. Remove the built up or pitted portions of the contacts with a contact file; be careful not to remove any more metal than is necessary.

(1) Reassemble the governor as indicated

in figure 81; the sequence for assembling the parts is the reverse of the disassembly sequence.

(2) Replace the governor on the motor by reversing the procedure described in paragraph 74*a*(7) through (9).

(3) Replace the motor (par. 60*d*).

(4) Adjust the motor (par. 270 through 273).

76. Removal and Replacement of Platen Frame Assembly

(fig. 82)

a. Disassembly.

(1) Remove the platen assembly from the teletypewriter frame (par. 62*a*).

(2) Remove the machine screw (3), lockwasher (4), and flat washer (5) that hold the platen-latching arm (6) to the platen frame (41); remove the platen-latching arm.

(3) Remove the platen-locking stud (7) from the platen frame (41).

(4) On the TT-4B/TG, remove the self-locking hexagonal nut (9), machine screw (10), and flat washer (11) that hold the platen-blocking arm (12) to the platen-blocking-arm bracket (16); remove the platen-blocking arm.

(5) On the TT-4B/TG, remove the machine screw (13), lockwasher (14), and flat washer (15) that hold the platen-blocking-arm bracket (16) to the platen frame (41); remove the platen-blocking-arm bracket.

(6) Remove the machine screw (17) and lockwasher (18) that hold the platen-shift arm (19) to the platen frame (41); remove the platen-shift arm.

(7) Remove the two machine screws (20) and lockwashers (21) that hold the platen knob (22) to the platen-knob spring (23); remove the platen knob and platen-knob spring from the platen shaft (28).

(8) On the TT-4A/TG, remove the four setscrews (26 and 27) that hold the platen (29) to the platen shaft (28).

(9) On the TT-4B/TG, remove the two setscrews that hold the platen (30) to the platen shaft (28).

(10) Remove the two setscrews (24) that

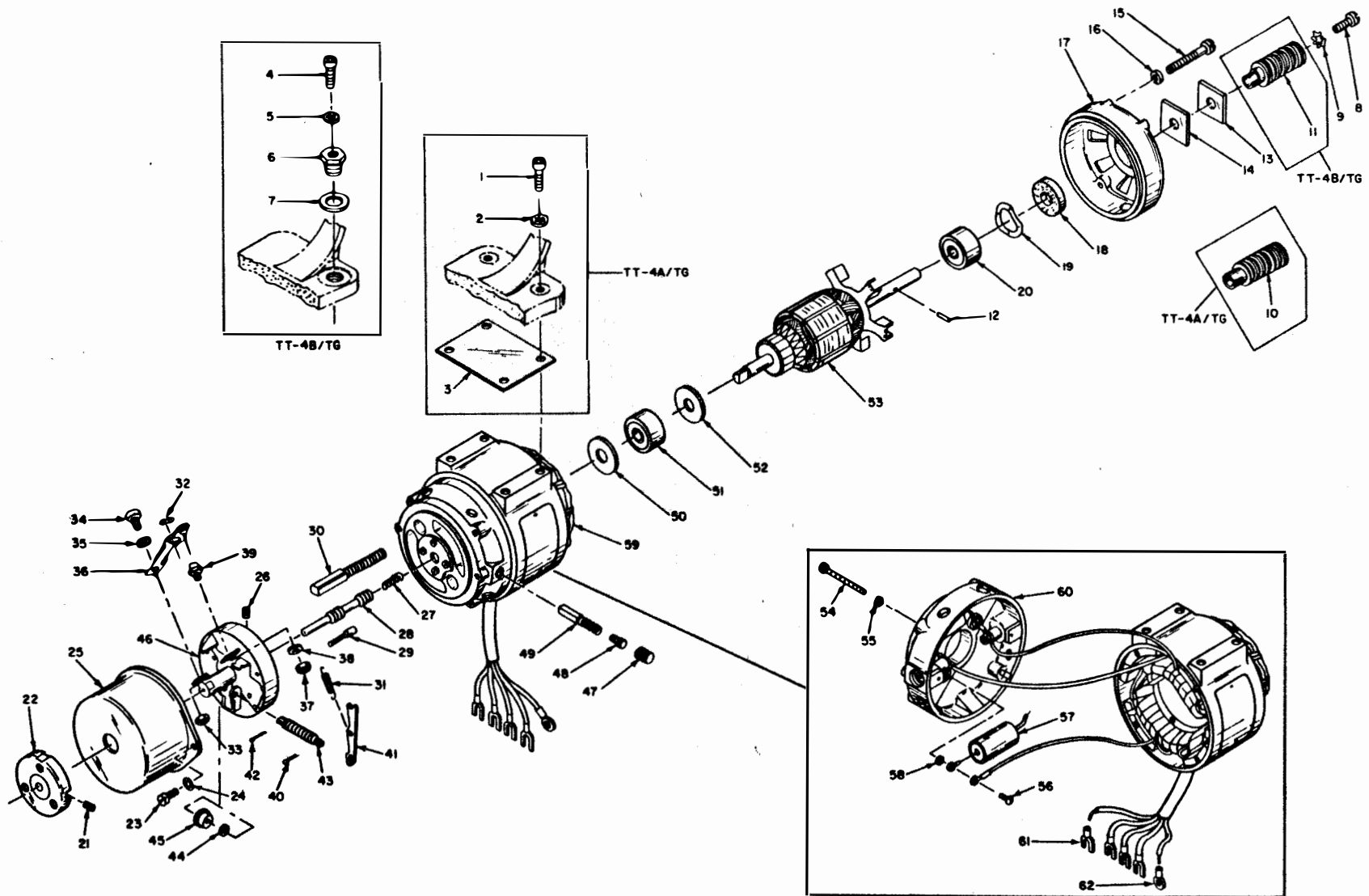

Figure 81. Motor and governor, exploded view.



Figure 81. Motor and governor, exploded view.

- | | | |
|---|---|--|
| 1. Machine screw, 10017-01 | 24. Lockwasher, 10412 | 44. Flat washer, 50148 |
| 2. Lockwasher, 10405 | 25. Governor cover, 50311 | 45. Speed adjustment gear, 50278A |
| 3. Shim, 50986 | 26. Setscrew, 10203 | 46. Governor base, 51249A |
| 4. Machine screw, 10018-01 | 27. Governor worm spring, 51855 | 47. Brush shield, 51155 ^a , 60495 ^b |
| 5. Lockwasher, 10405 | 28. Governor worm, 56555A ^a ,
53807A ^b | 48. Brush cap, 60496 |
| 6. Sleeve, 57493 | 29. Contact brush, 51154A | 49. Brush, 56834 ^a , 60503 ^b |
| 7. Lockwasher, 10482 | 30. Contact brush, 51543A | 50. Flat washer |
| 8. Machine screw, 50207 | 31. Governor spring, 50334 | 51. Ball bearing, 10760 ^a , 10765 ^b |
| 9. Lockwasher, 10406 | 32. Grooved pin, 50302 | 52. Flat washer |
| 10. Worm gear, 50350 | 33. Self-locking hexagonal nut,
10500 | 53. Armature, 51187 ^a , 60492 ^b (in-
cludes items 20, 21, and 51) |
| 11. Worm gear, 50350 | 34. Machine screw, 10001 | 54. Machine screw, 10172 |
| 12. Pin, 50359 | Lockwasher, 10403 | 55. Lockwasher, 10442 |
| 13. Grease seal, 50949 | 36. Contact, 50338 | 56. Machine screw |
| 14. Grease seal, 50949 | 37. Plain hexagonal nut, 10507 | 57. Capacitor C16 and C17, 20212 |
| 15. Machine screw, 10172 | 38. Lockwasher, 10404 | 58. Lockwasher |
| 16. Lockwasher, 10442 | 39. Contact, 50338 | 59. Motor housing, 51861A ^a ,
61109A ^b (main component of
motor which includes items 15
through 20 and 47 through 62) |
| 17. Gear end bell 20751 ^a , 60505 ^b | 40. Cotter pin, 10800 | 60. Governor end bell, 51804 ^a ,
60490 ^b |
| 18. Thrust pad | 41. Governor adjustment lever,
50 | 61. Terminal, 20706 |
| 19. Thrust washer | 42. Cotter pin, 10800 | 62. Terminal, 20708 |
| 20. Ball bearing, 10760 | 43. Governor adjustment screw,
50299 | |
| 21. Setscrew, 10204 | | |
| 22. Governor target, 50303A | | |
| 23. Machine screw, 10321 | | |

^a Used on Bodine motor.

^b Used on Howard motor.

Figure 81—Continued

- hold the line-feed ratchet (32) to the platen shaft (28).
- (11) Remove the two setscrews (25) that hold the shaft collar (34) to the platen shaft (28).
 - (12) Slide the platen shaft (28) from the assembly, removing the platen (29 or 30), platen trough, single-double line-feed lever (31), line-feed ratchet (32), bearing (33), shaft collar (34), the assembled line-feed lever (40), and line-feed pawl (39) from the shaft as it is withdrawn.
 - (13) Remove the line-feed-pawl spring (35) from the line-feed pawl (39) and from the line-feed lever (40).
 - (14) On the TT-4A/TG, remove the cotter pin (36) and flat washer (37) that hold the line-feed pawl (39) to the line-feed lever (40); remove the line-feed pawl.
 - (15) On the TT-4B/TG, remove the retainer ring (38) that holds the line-feed pawl (39) to the line-feed lever (40); remove the line-feed pawl.
- b. Reassembly.**
- (1) Reassemble the platen frame assembly as indicated in figure 82; the sequence for assembling the parts is the reverse of the disassembly sequence.
 - (2) Replace the platen assembly on the teletypewriter frame (par. 62b).

- (3) Adjust the platen assembly (par. 228 through 246).

77. Disassembly and Reassembly of Platen-Trough Assembly (TT-4A/TG) (fig. 83)

a. Disassembly.

- (1) Remove the platen assembly from the teletypewriter frame (par. 62a).
- (2) Remove the platen-trough assembly from the platen frame (par. 76a(2), (3), and (6) through (12)).
- (3) Remove the two cotter pins (3 and 8) and flat washers (4 and 9) that hold the connecting links (7 and 12) to the studs on the bracket link (13); remove the two connecting links.
- (4) Remove the line-feed-lever-detent spring (14) from the line-feed-lever detent (16) and from the spring post on the platen trough (41).
- (5) Remove the flat washer (15), line-feed-lever detent (16), and flat washer (17) from the stud on the platen trough (41).
- (6) Remove the line-spacing-detent spring (18) from the line-spacing detent (21) and from the spring post on the platen trough.
- (7) Remove the cotter pin (19) and flat washer (20) that hold the line-spacing detent (21) to the line-spacing

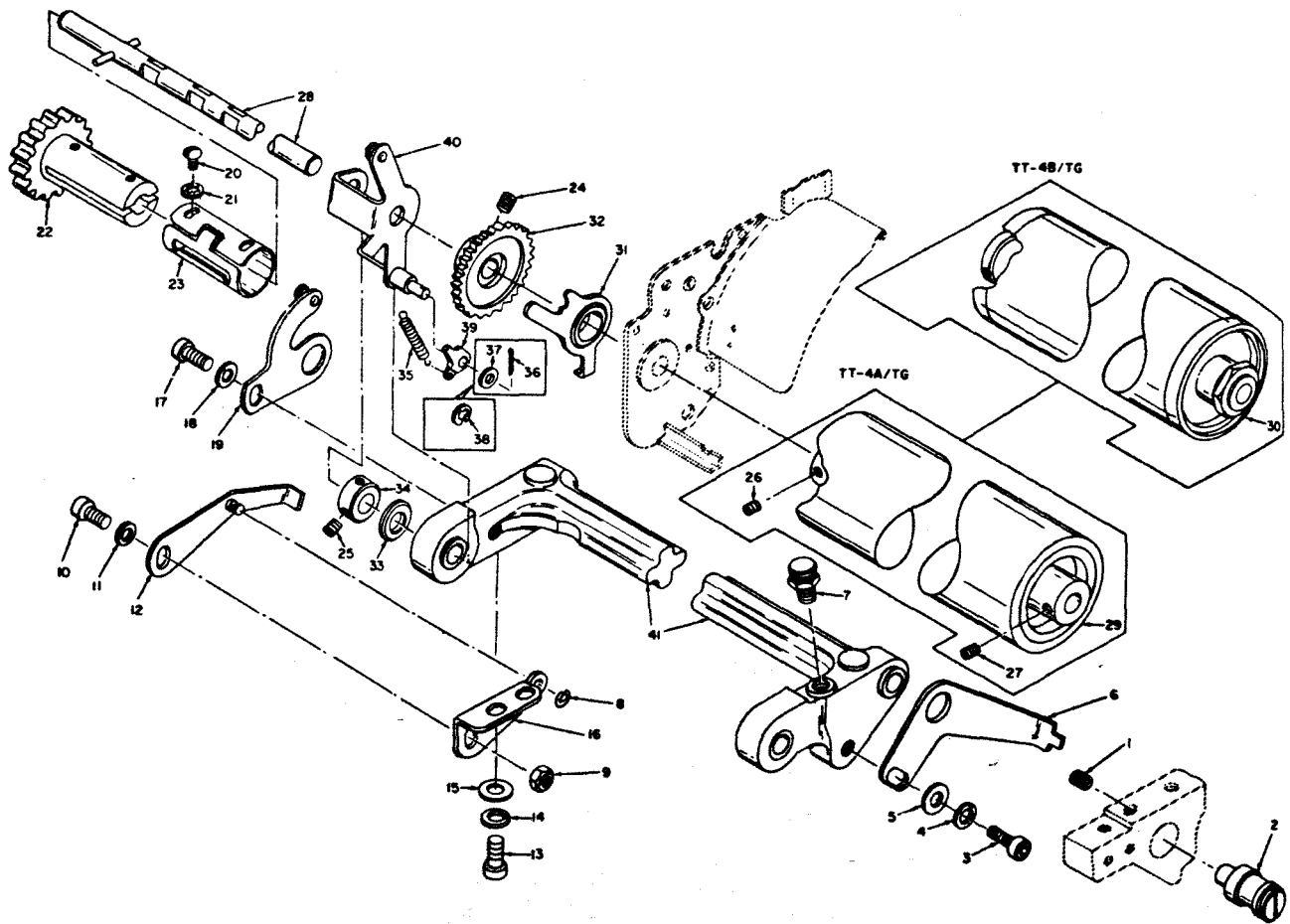

TM5815-206-35-48

- | | | |
|---|---|--|
| 1. Setscrew, 10211 | 16. Platen-blocking-arm bracket, 52307 ^b | 30. Platen, 57781A |
| 2. Eccentric pivot, 50239 | 17. Machine screw, 10015 | 31. Single-double line-feed lever, 51762A |
| 3. Machine screw, 10015 | 18. Lockwasher, 10405 ^a , 10431 ^b | 32. Line-feed ratchet, 51772 ^a , 52807 ^b |
| 4. Lockwasher, 10431 | 19. Platen-shift arm, 50213A ^a , 53134A ^b | 33. Bearing, 10707 |
| 5. Flat washer, 10481 | 20. Machine screw, 10305 | 34. Shaft collar, 50209 |
| 6. Platen-latching arm, 50214 | 21. Lockwasher, 10403 | 35. Line-feed-pawl spring, 50333 |
| 7. Platen-locking stud, 50762 | 22. Platen knob, 51690 | 36. Cotter pin, 10806 ^a |
| 8. Retainer ring, 10969 ^b | 23. Platen-knob spring, 51689 | 37. Flatwasher, 50320 ^a |
| 9. Self-locking hexagonal nut, 10501 ^b | 24. Setscrew, 10209 | 38. Retainer ring, 10969 ^b |
| 10. Machine screw, 10008 ^b | 25. Setscrew, 10209 | 39. Line-feed pawl, 50165 |
| 11. Flat washer, 10467 ^b | 26. Setscrew, 10209 | 40. Line-feed lever, 51759A ^a , 53137A ^b |
| 12. Platen-blocking arm, 53095A ^b | 27. Setscrew, 10209 | 41. Platen frame, 53305A |
| 13. Machine screw, 10008 ^b | 28. Platen shaft, 51687A | |
| 14. Lockwasher, 10430 ^b | 29. Platen, 50167A | |
| 15. Flatwasher, 10467 ^b | | |

^a Used on TT-4A/TG.

^b Used on TT-4B/TG.

Figure 82. Platen frame assembly, exploded view.

detent eccentric stud (23); remove the line-spacing detent.

- (8) Remove the self-locking hexagonal nut (22) that holds the line-spacing-detent eccentric stud (23) to the platen trough (41); remove the line-spacing-detent eccentric stud.
- (9) Remove the two setscrews (24) that

hold the pressure-roller lever (25) to the pressure-roller control shaft (27); remove the pressure-roller lever.

- (10) Remove the pressure-roller-control shaft screw (26) that holds the pressure-roller control shaft (27) to the platen trough (41); remove the pressure-roller control shaft and the as-

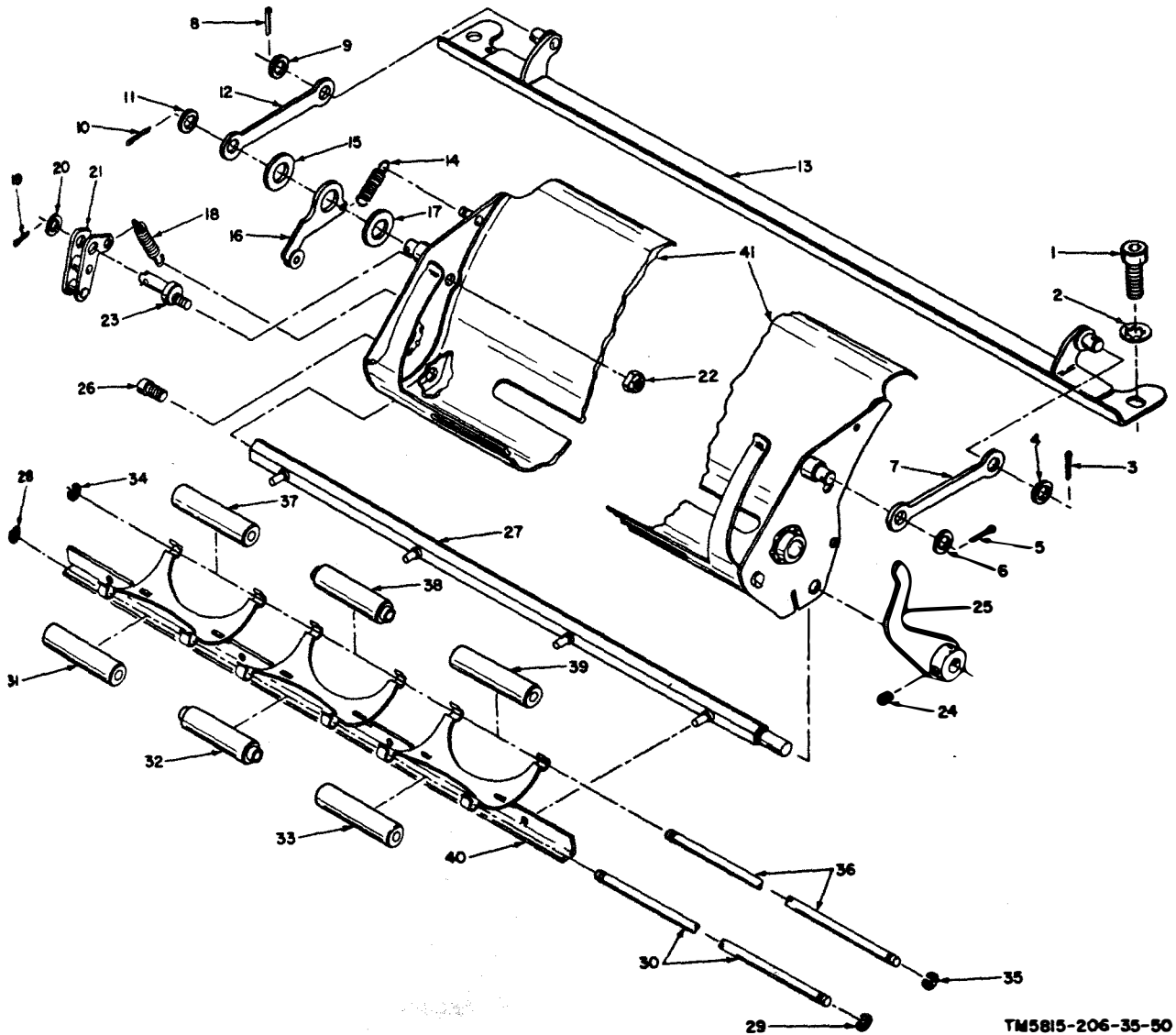

- | | | |
|--|--|--|
| 1. Machine screw, 10015 | 16. Line-feed-lever detent, 51765A | 28. Retainer ring, 51099 |
| 2. Lockwasher, 10405 | 17. Flat washer, 51768 | 29. Retainer ring, 51099 |
| 3. Cotterpin, 10802 | 18. Line-spacing-detent spring, 50332 | 30. Pressure-roller shaft, 50234 |
| 4. Flat washer, 50315 | 19. Cotterpin, 10802 | 31. Platen pressure roller, 52122 |
| 5. Cotterpin, 10802 | 20. Flat washer, 50319 | 32. Platen pressure roller, 50161A |
| 6. Flat washer, 50315 | 21. Line-spacing detent, 50108A | 33. Platen pressure roller, 52122 |
| 7. Connecting link, 50215 | 22. Self-locking hexagonal nut, 10500 | 34. Retainer ring, 51099 |
| 8. Cotterpin, 10802 | 23. Line-spacing-detent eccentric stud, 51769 | 35. Retainer ring, 51099 |
| 9. Flat washer, 50315 | 24. Setscrew, 10201 | 36. Pressure-roller shaft, 50234 |
| 10. Cotterpin, 10802 | 25. Pressure-roller lever, 50177A | 37. Platen pressure roller, 52122 |
| 11. Flat washer, 50315 | 26. Pressure-roller-operating-shaft screw, 50238 | 38. Platen pressure roller, 50161A |
| 12. Connecting link, 50215 | 27. Pressure-roller operating shaft, 50230A | 39. Platen pressure roller, 52122 |
| 13. Bracket link, 51461A | | 40. Pressure-roller mounting bar, 50229A |
| 14. Line-feed-lever-detent spring, 51851 | | 41. Platen trough, 51756A |
| 15. Flat washer, 51768 | | |

Figure 85. Platen-trough assembly (TT-4A/TG), exploded view.

sembled pressure-roller mounting bar (items 28 through 40).
 (11) Remove the four retainer rings (28,

29, 34, and 35) that hold the two pressure-roller shafts (30 and 36) in the pressure-roller mounting bar (40);

withdraw the two pressure-roller shafts, removing the six platen pressure rollers (31, 32, 33, 37, 38, and 39) from the pressure-roller mounting bar.

b. Reassembly.

- (1) Reassemble the platen-trough assembly as indicated in figure 83; the sequence for assembling the parts is the reverse of the disassembly sequence. Be sure that the hub of the pressure-roller lever (25) is tight against the shoulder on the pressure-roller operating shaft (27) before tightening the two setscrews (24).
- (2) Replace the platen-trough assembly on the platen frame (par. 76*b*).
- (3) Replace the platen assembly on the platen frame (par. 62*b*).
- (4) Adjust the platen-trough assembly (par. 229, 230, 233 through 238, 240, and 243 through 246).

**78. Disassembly and Reassembly of
Platen-Trough Assembly (TT-4B/TG)
(fig. 84)**

a. Disassembly.

- (1) Remove the platen assembly from the teletypewriter frame (par. 62*a*).
- (2) Remove the platen-trough assembly from the platen frame (par. 76*a*(2) through (9)).
- (3) Remove the retainer rings (4 and 5) that hold the connecting link (6) to the platen trough (42) and to the bracket link (12); remove the connecting link.
- (4) Remove the platen lever-latch spring (7) from the spring post on the platen trough (42) and from the platen lever latch (8). Remove the flat washer (43), platen lever latch, and flat washer (44) from the stud on the platen trough.
- (5) Remove the retainer rings (9 and 10) that hold the connecting link (11) to the bracket link (12) and the stud on the platen trough (42); remove the connecting link and bracket link.
- (6) Remove the line-feed-lever-detent spring (13) from the line-feed-lever

detent (15) and from the spring post on the platen trough (42).

- (7) Remove the flat washer (14), line-feed-lever detent (15), and flat washer (16) from the stud on the platen trough (42).
- (8) Remove the line-spacing-detent spring (17) from the line-spacing detent (19) and from the spring post on the platen trough (42).
- (9) Remove the retainer ring (18) that holds the line-spacing detent (19) to the line-spacing detent stud (22); remove the line-spacing.
- (10) Remove the plain round nut (20) and lockwasher (21) that hold the line-spacing-detent stud (22) on the platen trough (42); remove the line-spacing-detent stud.
- (11) Remove the two setscrews (23) that hold the pressure-roller lever (24) to the pressure-roller-control shaft (30); remove the pressure-roller lever and flat washer (45).
- (12) Remove the pressure-roller-operating-shaft screw (25) that holds the pressure-roller-operating shaft (30) to the platen trough (42); remove the pressure-roller operating shaft.
- (13) Remove the two retainer rings (26 and 27) that hold the pressure-roller shaft (28) in the pressure-roller operating shaft (30); remove the pressure-roller shaft and the platen pressure roller (29) from the pressure-roller operating shaft.
- (14) Remove the two paper-guide springs (31) from the two paper guides (36 and 37) and from the spring posts on the platen trough (42).
- (15) Remove the pivot screw (32) that holds the paper-guide shaft (35) to the platen trough (42); remove the paper-guide shaft.
- (16) Remove the two setscrews (33 and 34) that hold the two paper guides (36 and 37) to the paper-guide shaft (35); remove the paper-guide shaft.
- (17) Remove the hinge pin (38) that holds the two platen-trough springs (39 and 40) and platen-trough guide (41)

to the platen trough (42); remove the platen-trough springs and platen-trough guide.

b. Reassembly.

- (1) Reassemble the platen-trough assembly as indicated in figure 84; the sequence for assembling the parts is the reverse of the disassembly sequence.
- (2) Replace the platen-trough assembly on the platen frame (par. 76b).
- (3) Replace the platen assembly on the teletypewriter frame (par. 62b).
- (4) Adjust the platen-trough assembly (par. 228 through 232, 234 through 237, and 239 through 245).

79. Removal and Replacement of Type-Selecting Arm
(fig. 85)

a. Removal.

- (1) Set all five code rings to the counterclockwise position, trip the function-shaft clutch, and turn the motor manually until the square-shaft stop arm strikes the blank stop bar.
- (2) On the TT-4A/TG, remove the two machine screws (5) and lockwashers (6) that hold the bearing cap to the carriage frame (27); remove the bearing cap and the type-selecting arm (3, fig. 86).
- (3) On the TT-4B/TG, remove the two machine screws (5, fig. 85), lockwashers (6), and flat washers (7) that hold the bearing cap to the carriage frame (27); remove the bearing cap and the type-selecting arm.

b. Replacement.

- (1) Manually select the blank code group and turn the motor by hand until the square shaft stops turning. Install the type-selecting arm so that the type-selecting arm is in the blank code group position (the last notch in the right side of the guide plate).
- (2) Replace the type-selecting arm by reversing the procedure described in a(2) or (3) above.
- (3) Check and adjust the type-selecting arm (par. 223 through 227).

80. Disassembly and Reassembly of Type-Selecting Arm
(fig. 86)

a. Disassembly.

- (1) Remove the type-selecting arm (par. 79a).
- (2) Remove the plain hexagonal nut (1) and the grooved nut (2) from the type-selecting arm (3); remove the type-selecting arm from the type-selecting-arm claw (12).
- (3) Remove the plain hexagonal nut (4) and lockwasher (5) from the type-selecting-arm claw (12).
- (4) Remove the type-selecting-arm gear (6) and machine key (7) from the type-selecting-arm claw (12).
- (5) Remove the ball bearing (8), flat washer, (9), spacing collar (10), and ball bearing (11) from the type-selecting-arm claw (12).

b. Reassembly.

- (1) Reassemble the type-selecting arm as indicated in figure 86; the sequence for assembling the parts is the reverse of the disassembly sequence.
- (2) Replace the type-selecting arm (par. 79b).

81. Disassembly and Reassembly of Ribbon Lifter Assembly (TT-4A/TG)
(fig. 87)

a. Disassembly.

- (1) Remove the carriage (par. 63a).
- (2) Remove the ribbon guide (1) from the ribbon-lifter bell crank (15).
- (3) Remove the bell-crank spring (4) from the ribbon-lifter-lever assembly (7) and from the ribbon-lifter bell crank (15).
- (4) Remove the two machine screws (2) and lockwashers (3) that hold the ribbon-lifter-lever assembly (7) to the carriage; remove the ribbon-lifter-lever assembly.
- (5) Remove the cotter pin (5) and pin (6) that hold the ribbon-lifter-lever assembly (7) to the link (8); remove the ribbon-lifter-lever assembly.
- (6) Remove the ribbon-lifter turnbuckle (9) from the links (8 and 12).
- (7) Remove the cotter pin (10) and pin

Figure 84. Platen-trough assembly (TT-4B/TG), exploded view.

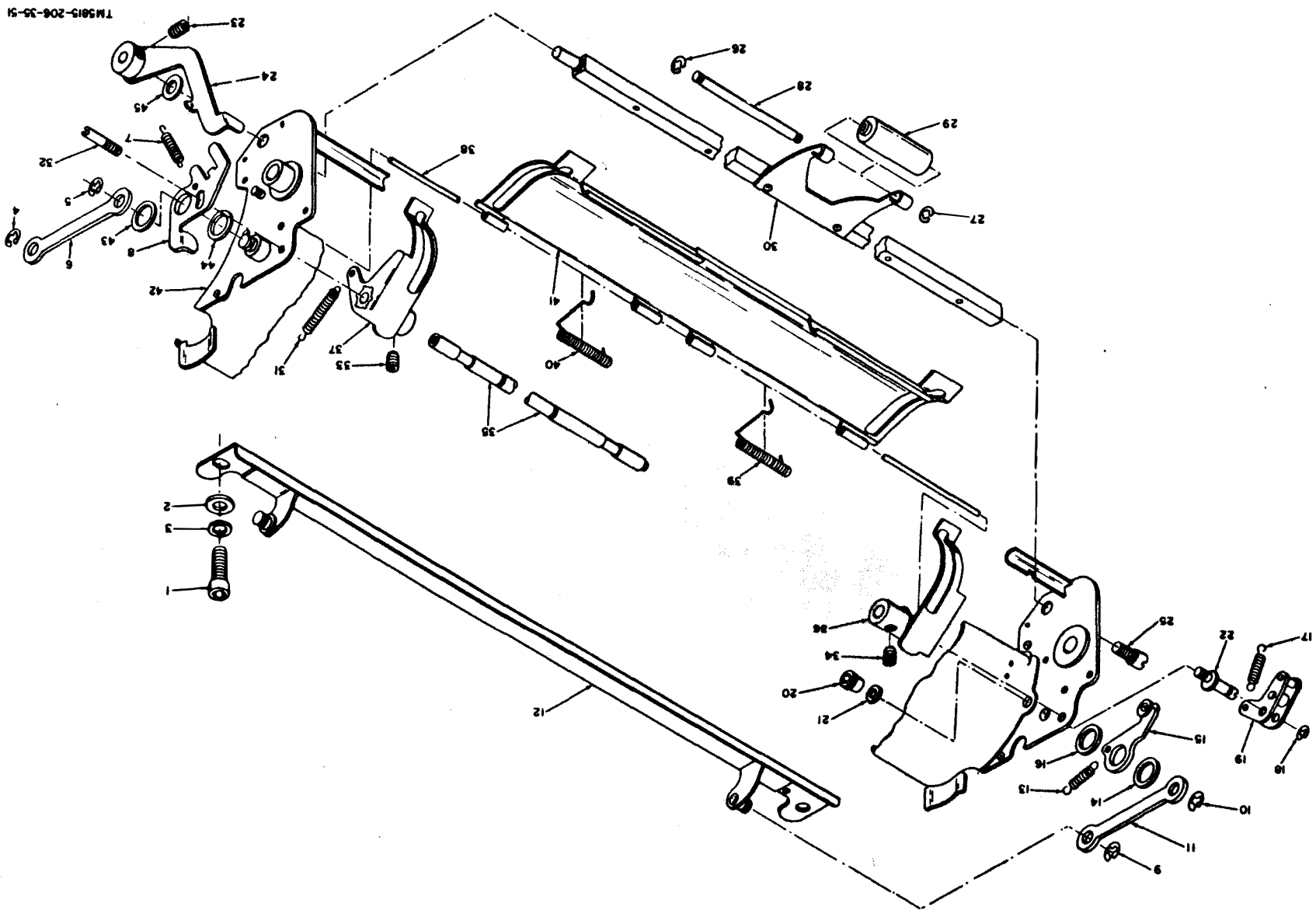

TM5815-208-35-51

- | | | |
|--|--|--|
| 1. Machine screw, 10024 | 17. Line-spacing-detent spring, 51851 | 31. Paper-guide spring, 52169 |
| 2. Flat washer, 10464 | 18. Retainer ring, 10960 | 32. Pivot screw, 55139 |
| 3. Lockwasher, 10431 | 19. Line-spacing detent, 50108A | 33. Setscrew, 10201 |
| 4. Retainer ring, 10949 | 20. Plain round nut, 10537 | 34. Setscrew, 10201 |
| 5. Retainer ring, 10949 | 21. Lockwasher, 10429 | 35. Paper-guide shaft, 55152 |
| 6. Connecting link, 50215 | 22. Lie-spacing-detent stud, 52931 | 36. Paper guide, 55144A |
| 7. Platen lever-latch spring, 53149 | 23. Setscrew, 10201 | 37. Paper guide, 55141A |
| 8. Platen lever latch, 54951 | 24. Pressure-roller lever, 54954A | 38. Hinge pin, 55146 |
| 9. Retainer ring, 10949 | 25. Pressure-roller-operating-shaft screw, 50238 | 39. Platen-trough spring, 54967 |
| 10. Retainer ring, 10949 | 26. Retainer ring, 51099 | 40. Plate-trough spring, 54967 |
| 11. Connecting link, 50215 | 27. Retainer ring, 51099 | 41. Platen-trough guide, 54962 |
| 12. Bracket link, 53138A | 28. Pressure-roller shaft, 54968 | 42. Platen trough, 54136A (Items 38 through 42 are part of platen-trough assembly, 59432A) |
| 13. Line-feed-lever-detent spring, 51851 | 29. Platen pressure roller, 50161A | 43. Flat washer, 51768 |
| 14. Flat washer, 51768 | 30. Pressure-roller operating shaft, 55530A | 44. Flat washer, 51768 |
| 15. Line-feed-lever detent, 53202A | | 45. Flat washer, 50315 |
| 16. Flat washer, 51768 | | |

Figure 84—Continued

(11) that hold the link (12) to the ribbon-lifter bell crank (15); remove the link.

- (8) Remove the cotter pin (13) and pin (14) that hold the ribbon-lifter bell crank (15) to the slide bearing (16); remove the ribbon-lifter bell crank.

b. Reassembly.

- (1) Reassemble the ribbon lifter assembly as indicated in figure 87; the sequence for assembling the parts is the reverse of the disassembly sequence.

Note. Be sure to insert the end of the ribbon guide (1) into the notch in the ribbon-lifter bell crank (15); also, be sure that the lip of the pressure-roller mounting bar (40, fig. 83) engages the notch in the slide bearing (16, fig. 87).

- (2) Replace the carriage (par. 63b).
 (3) Adjust the ribbon lifter assembly (par. 227).

82. Disassembly and Reassembly of Ribbon Lifter Assembly (TT-4B/TG) (fig. 88)

a. Disassembly.

- (1) Remove the carriage (par. 63a).
 (2) Remove the ribbon guide (1) from the ribbon-lifter bell crank (9).
 (3) Remove the ribbon-lifter spring (4) from the ribbon-lifter-lever assembly (8) and from the ribbon-lifter bell crank (9).
 (4) Remove the two machine screws (2) and lockwashers (3) that hold the ribbon-lifter-lever assembly (8) to

the carriage; remove the assembled ribbon-lifter-lever assembly.

- (5) Remove the two machine screws (5), lockwashers (6), and flat washers (7) that hold the ribbon-lifter-lever assembly (8) to the ribbon-lifter bell crank (9); remove the ribbon-lifter-lever assembly.

b. Reassembly.

- (1) Reassemble the ribbon lifter assembly as indicated in figure 88; the sequence for assembling the parts is the reverse of the disassembly sequence.

Note. Be sure the end of the ribbon guide (1) engages the notch in the front of the ribbon-lifter bell crank (9); also, be sure the lip of the cross rail of the platen trough (42, fig. 84) engages the notch in the rear of the bearing of the ribbon-lifter bell crank (9, fig. 88).

- (2) Replace the carriage (par. 63b).
 (3) Adjust the ribbon lifter assembly (par. 227).

83. Disassembly and Reassembly of Ribbon-Feed Mechanism (fig. 89)

a. Disassembly.

- (1) Remove the ribbon from the ribbon guide (1, fig. 87 or 88).
 (2) On the TT-4A/TG, lift the ribbon-spool lock (30, fig. 89) and press down on the ribbon-sensing levers (31) to remove the ribbon spools (1) from the ribbon-spool shafts (24). Remove the ribbon spools and the winding ribbon.
 (3) On the TT-4B/TG, lift the ribbon-spool lock (30) and press in the rib-

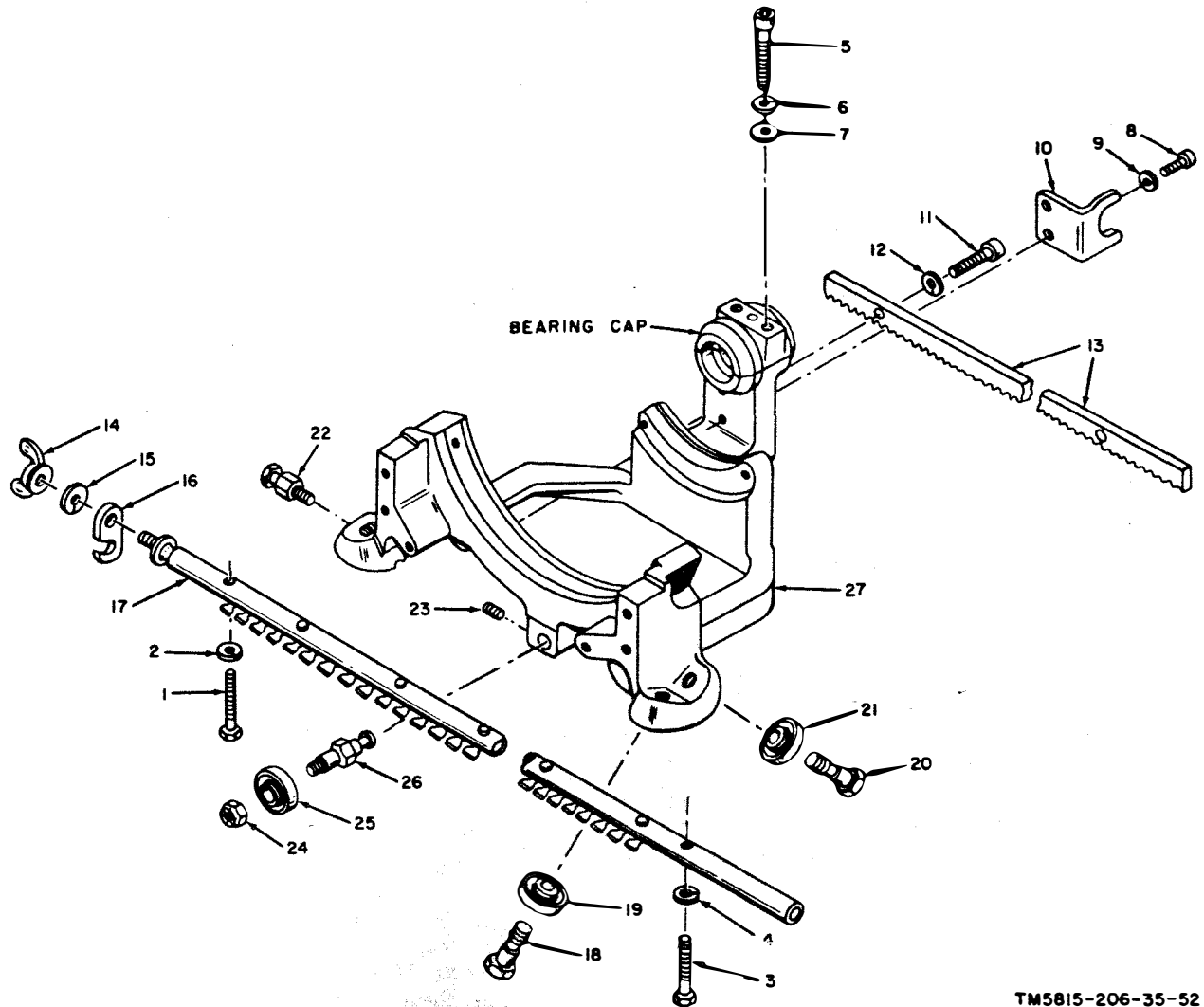

TM5815-206-35-52

- | | | |
|--|---|---------------------------------------|
| 1. Machine screw, 10319 | 11. Machine screw, 10011 | 19. Ball bearings, 10752 |
| 2. Lockwasher, 10404 | 12. Lockwasher, 10430 | 20. Carriage-roller screws, 50591 |
| 3. Machine screw, 10320 | 13. Carriage rack, 50592 | 21. Ball bearing, 10752 |
| 4. Lockwasher, 10404 | 14. Plain wing nut, 10508 | 22. Carriage-locking stud, 50594 |
| 5. Machine screw, 10012*, 10063* | 15. Lockwasher, 10431 | 23. Setscrew, 10204 |
| 6. Lockwasher, 10430 | 16. Platen-locking arm, 50598 | 24. Self-locking hexagonal nut, 10501 |
| 7. Flat washer, 10467* | 17. Carriage guide rail, 50394A (includes items 14, 15, and 16) | 25. Ball bearing, 10752 |
| 8. Machine screw, 10003 | 18. Carriage-roller screws, 50591 | 26. Roller-mounting stud, 50593 |
| 9. Lockwasher, 10429 | | 27. Carriage frame, 50545A |
| 10. Carriage rear-support bracket, 50571 | | |

* Used on TT-4A/TG.

* Used on TT-4B/TG.

Figure 85. Carriage frame assembly, exploded view.

bon-sensing levers (20) toward the outside of the levers to remove the ribbon spools (1) from the ribbon-spool shafts (24); remove the ribbon spools and the printing ribbon.

- (4) Remove the six machine screws (2) and lockwashers (3) that hold the rib-

bon-feed mechanism to the carriage frame; remove the ribbon-feed mechanism.

- (5) Remove the four machine screws (4), lockwashers (5), and two retainer plates (6) that hold the type-bar backstop (7) to the two ribbon-spool

9
8
13
206-35-52
50591
50594
nut,
50593
A
the car-
bon-feed
ws (4),
retainer
type bar
ool

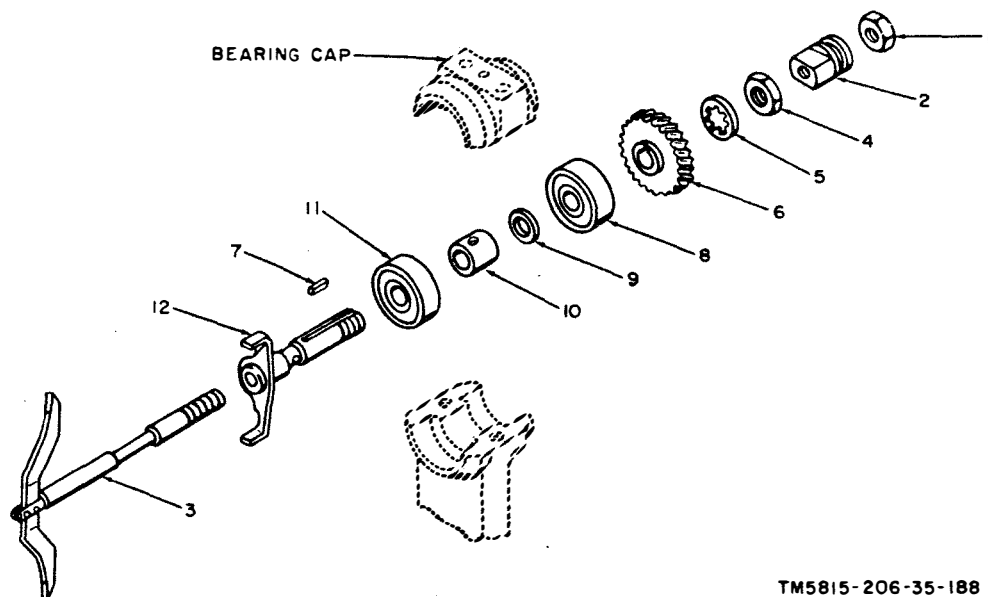

TM5815-206-35-188

- | | | |
|-------------------------------|-----------------------------------|-------------------------------------|
| 1. Plain hexagonal nut, 10509 | 5. Lockwasher, 10401 | 9. Flat washer, 50552 |
| 2. Grooved nut, 50564 | 6. Type-selecting-arm gear, 50556 | 10. Spacing collar, 50557 |
| 3. Type-selecting arm, 50560A | 7. Machine key, 50558 | 11. Ball bearing, 10757 |
| 4. Plain hexagonal nut, 50559 | 8. Ball bearing, 10757 | 12. Type-selecting-arm claw, 50553A |

Figure 86. Type-selecting arm assembly, exploded view.

- mounting brackets (29); remove the type-bar backstop.
- (6) Remove the two self-locking hexagonal nuts (8) and two machine screws (9) that hold the ribbon-drive assembly (14) to the two ribbon-spool mounting brackets (29); disengage the ribbon-drive assembly from the pins on the ribbon-reverse-cam followers (19) and from the two ribbon-spool mounting brackets.
 - (7) Remove the ribbon-reverse-detent spring (10) from the detent lever and the frame of the ribbon-drive assembly (14).
 - (8) Remove the two machine screws (11) and lockwashers (12) that hold the ribbon-reverse detent (13) to the ribbon-drive assembly (14); remove the ribbon-reverse detent.
 - (9) Remove the two ribbon-sensing-lever springs (15) from the two ribbon-sensing levers (20 or 31) and from the two ribbon-spool mounting brackets (29).
 - (10) On the TT-4A/TG, remove the two machine screws (16), lockwashers (18), and flat washers (17) that hold the two ribbon-sensing levers (31) to the two ribbon-spool mounting brackets (29); remove the ribbon-sensing levers and slide off the two ribbon-reverse-cam followers (19).
 - (11) On the TT-4B/TG, remove the two machine screws (16), lockwashers (18), and flat washers (17) that hold the two ribbon-sensing levers (20) to the two ribbon-spool mounting brackets (29); remove the ribbon-sensing levers and slide off the two ribbon-reverse-cam followers (19).
 - (12) Remove the four setscrews (21) that hold the two spool-driving collars (22) to the two ribbon-spool shafts (24); remove the spool-driving collars.
 - (13) On the TT-4B/TG, remove the four setscrews (23) that hold the two shaft collars (27) to the two ribbon-spool shafts (24); slide the ribbon-spool shafts from the two ribbon-spool mounting brackets (29) and remove the two flat washers (25), two spool-shaft springs (26), and shaft collars

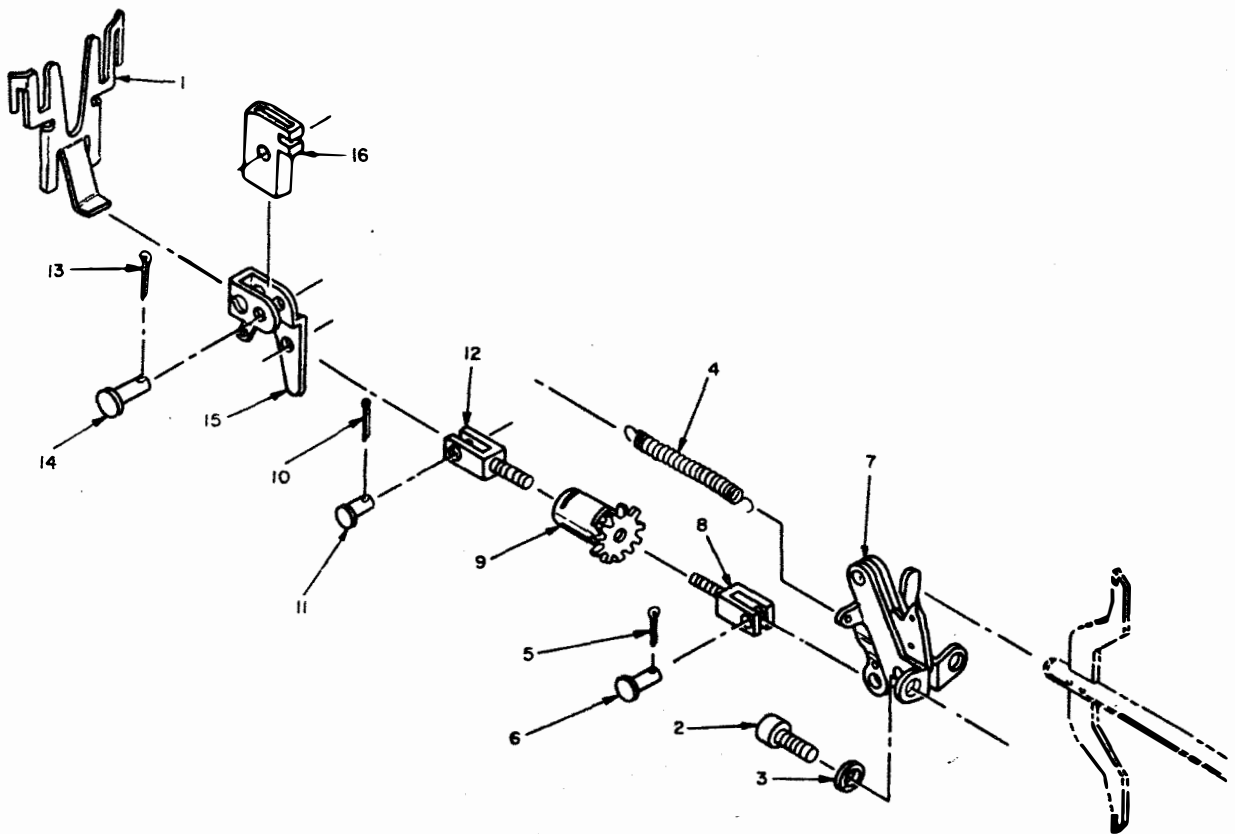

TM5815-206-35-53

- | | | |
|-----------------------------|------------------------------------|-------------------------------------|
| 1. Ribbon guide, 50590 | 7. Ribbon-lifter-lever assembly, | 12. Link, 50584 |
| 2. Machine screw, 10001 | 53906A | 13. Cotter pin, 10806 |
| 3. Lockwasher, 10429 | 8. Link, 50577 | 14. Pin, 50588 |
| 4. Bell-crank spring, 50575 | 9. Ribbon-lifter turnbuckle, 50586 | 15. Ribbon-lifter bell crank, 53904 |
| 5. Cotter pin, 10806 | 10. Cotter pin, 10805 | 16. Slide bearing 50587 |
| 6. Pin, 50578 | 11. Pin, 50578 | |

Figure 87. Ribbon lifter assembly (TT-4A/TG), exploded view.

- (27) from the shafts as they are removed.
- (14) Remove the two ribbon-spool-shaft gears (28) from the two ribbon-spool shafts (24).
- b. Reassembly.**
- (1) Reassemble the ribbon-feed mechanism as indicated in figure 89; the sequence for assembling the parts is the reverse of the disassembly sequence.
- (2) Adjust the ribbon-feed mechanism (par. 251 through 259).
- 84. Disassembly and Reassembly of Type-Bar Group (fig. 90)**
- a. Disassembly.**
- (1) Remove the carriage assembly (par. 63a).
- (2) On the TT-4A/TG, remove the ribbon lifter assembly (par. 81a).
- (3) On the TT-4B/TG, remove the ribbon lifter assembly (par. 82a).
- (4) Remove the ribbon-feed mechanism (par. 83a).
- (5) Remove the 26 connecting-bar springs (1) from the connecting bars (4) and from the mounting plate (17).
- (6) Loosen the two plain hexagonal nuts (5) and setscrews (7) to remove the hinge pin (2) that holds the 26 type bars (3) in the type-bar segment (14); remove the type bars and the 26 connecting bars (4) from the guide plate (18).
- (7) Remove the two plain hexagonal nuts (5), lockwashers (6), and setscrews

(7) that hold the type-bar segment key (8) and type-bar segment (14) to the carriage frame; remove the type-bar segment key and type-bar segment.

(8) Remove the two machine screws (9) that hold the ribbon-guide mounting bracket (10) to the type-bar segment (14); remove the ribbon-guide mounting bracket.

(9) On the TT-4A/TG, remove the four machine screws (11) that hold the type-bar bumper plate (19) and the bumper-plate shim (13) to the type-bar segment (14); remove the type-bar bumper plate and bumper-plate shim.

(10) On the TT-4B/TG, remove the four machine screws (11) that hold the type-bar bumper plate (12) and the bumper-plate shim (13) to the type-bar segment (14); remove the type-bar bumper plate and bumper-plate shim.

(11) Remove the two machine screws (15) and lockwashers (16) that hold the mounting plate (17) and the guide plate (18) to the carriage frame; remove the mounting plate and guide plate.

b. Reassembly.

(1) Reassemble the type-bar group as indicated in figure 90; the sequence for assembling the parts is the reverse of the disassembly sequence.

(2) Position the 26 connecting bars (4) and the 26 type bars (3) in the type-bar segment (14) with the connecting bars in the guide plate (18). Numbers 1 through 26 are stamped on both the connecting bars and the type bars. Install the bars in matched pairs; install the No. 1 pair on the left side of the carriage. Bar identification data is given in the following chart:

Type-bar and connecting-bar chart

Number stamped in bar	Connecting-bar reference No.	Type-bar reference No.	Type-bar letter	Upper-case symbol
1	50022	50054A	Z	.
2	50023	50055A	J	'
3	50024	50056A	X	/
4	50025	50057A	V	;
5	50026	50058A	B	?
6	50027	50059A	C	:
7	50028	50060A	P	0
8	50029	50061A	M	.
9	50030	50062A	F	1
10	50031	50063A	R	4
11	50032	50064A	O	9
12	50033	50065A	I	8
13	50034	50066A	T	5
14	50035	50067A	E	3
15	50036	50068A	A	-
16	50037	50069A	S	
17	50038	50070A	H	
18	50039	50071A	N	,
19	50040	50072A	L)
20	50041	50073A	D	\$
21	50042	50074A	U	7
22	50043	50075A	G	&
23	50044	50076A	Y	6
24	50045	50077A	W	2
25	50046	50078A	K	(
26	50047	50079A	Q	1

* Used on TT-4A/TG.

• Used on TT-4B/TG.

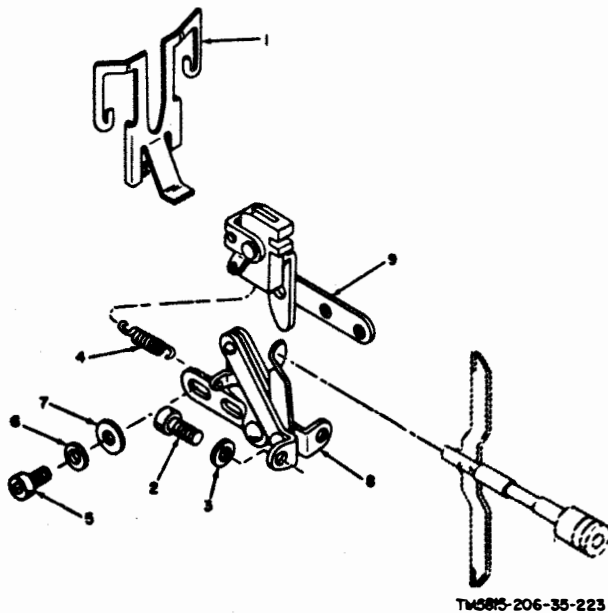

TMS815-206-35-223

- | | |
|--------------------------------|---|
| 1. Ribbon guide, 55036 | 6. Lockwasher, 10432 |
| 2. Machine screw, 10001 | 7. Flat washer, 50320 |
| 3. Lockwasher, 10429 | 8. Ribbon-lifter-lever assembly, 55790A |
| 4. Ribbon-lifter spring, 51544 | 9. Ribbon-lifter bell crank, 55795A |
| 5. Machine screw, 10050 | |

Figure 88. Ribbon lifter assembly (TT-4B/TG), exploded view.

- (3) Thread the hinge pin (2) in the type-bar segment (14) through the holes in the 26 type bars (3); tighten the two setscrews (7) against the hinge pin with from 1/2- to 1 1/2 inch-pound torque and secure the plain hexagonal nuts (5).
- (4) Install the 26 connecting-bar springs (1) on the mounting plate (17) and on the 26 connecting bars (4).
- (5) Replace the ribbon-feed mechanism (par. 83b).
- (6) On the TT-4A/TG, replace the ribbon lifter assembly (par. 81b).
- (7) On the TT-4B/TG, replace the ribbon lifter assembly (par. 82b).
- (8) Replace the carriage assembly (par. 63b).

85. Disassembly and Reassembly of Carriage Frame Assembly (fig. 85)

a. Disassembly.

- (1) Remove the carriage assembly from the teletypewriter frame (par. 63a).
- (2) Remove the two machine screws (11)

- and lockwashers (12) that hold the carriage rack (13) to the carriage frame (27); remove the carriage rack.
- (3) Only if necessary remove the plain wing nut (14) and lockwasher (15) that hold the platen-locking arm (16) on the threaded end of the carriage guide rail (17); remove the platen-locking arm from the carriage guide rail.

- (4) Remove the carriage guide rail (17) from the assembled ball bearings (19, 21, and 25) by moving the carriage guide rail to the left, out of the ball bearings.

- (5) Remove the two carriage-roller screws (18) that hold the ball bearings (19) to the carriage frame (27); remove the ball bearings.

- (6) Remove the two carriage-roller screws (20) that hold the ball bearings (21) to the carriage frame (27); remove the ball bearings.

- (7) Remove the carriage-locking stud (22) from the carriage frame (27).

- (8) Remove the self-locking hexagonal nut (24) that holds the ball bearing (25) to the roller-mounting stud (26); remove the ball bearing.

- (9) Remove the setscrew (23) that holds the roller-mounting stud (26) in the carriage frame (27); remove the roller-mounting stud.

b. Reassembly.

- (1) Reassemble the carriage frame assembly as indicated in figure 85; the sequence for assembling the parts is the reverse of the disassembly sequence.
- (2) Replace the carriage assembly on the teletypewriter (par. 63b).
- (3) Adjust the carriage frame assembly (par. 207 and 208).

86. Disassembly and Reassembly of Selector-Magnet Assembly (fig. 91)

a. Disassembly.

- (1) Remove the armature spring (30, fig. 80) from the armature-spring arm (33) and from the selector-magnet armature (8, fig. 91).

hat hold the
the carriage
arm rack
ve the plain
washer (15)
ng arm (16)
the carriage
the platen-
rriage guide

le rail (17)
earings (19,
he carriage
of the ball

oller screws
arings (19)
(7); remove

oller screws
arings (21)
(7); remove

king stud
e (27).

agonal nut
arings (25)
(2); re-

that holds
(16) in the
move the

ne assem-
5; the se-
rts is the
uence.

y on the
assembly

(30, fig.
ng arm
magnet

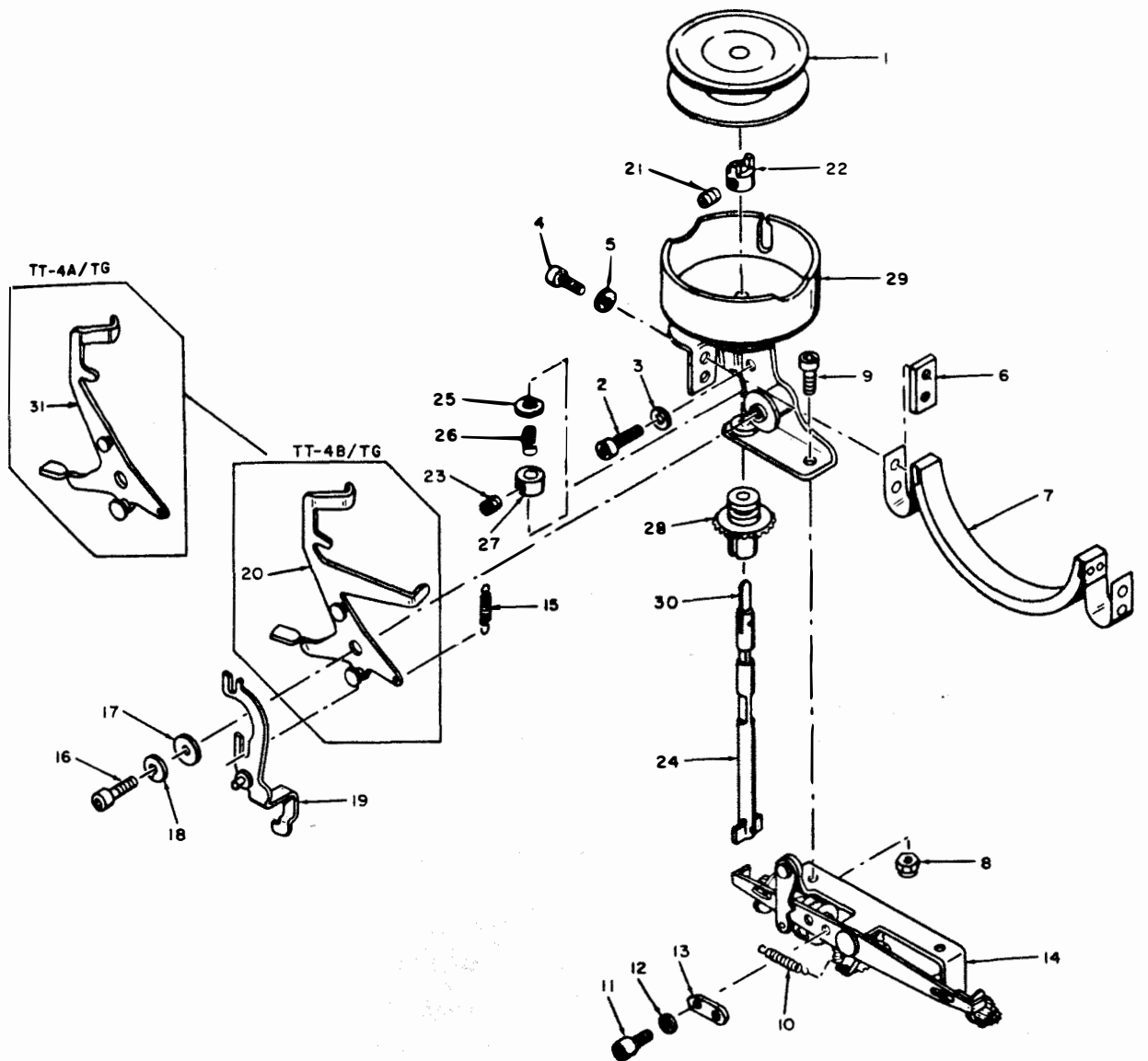

TM5815-206-35-54

- | | | |
|--|--|--|
| 1. Ribbon spool, 10900 | 12. Lockwasher, 10429 | 21. Setscrew, 10201 |
| 2. Machine screw, 10004 | 13. Ribbon-reverse detent, 50393 | 22. Spool-driving collar, 50392 |
| 3. Lockwasher, 10429 | 14. Ribbon-drive assembly, 50400A
(includes items 11, 12, and 13) | 23. Setscrew, 10201 |
| 4. Machine screw, 10001 | 15. Ribbon-sensing-lever spring,
50447 | 24. Ribbon-spool shaft, 50435A |
| 5. Lockwasher, 10429 | 16. Machine screw, 10003 | 25. Flat washer, 50315 |
| 6. Retainer plate, 50434 | 17. Flat washer, 50414 | 26. Spool-shaft spring, 53961 |
| 7. Type-bar backstop, 50429A | 18. Lockwasher, 10429 | 27. Shaft collar, 50391 |
| 8. Self-locking hexagonal nut,
10500 | 19. Ribbon-reverse-cam follower,
50423A (lh), 50424A (rh) | 28. Ribbon-spool-shaft gear, 50448 |
| 9. Machine screw, 10003 | 20. Ribbon-sensing lever, 55026A
(lh), 55028A (rh) | 29. Ribbon-spool mounting bracket,
50451A (lh), 50453A (rh) |
| 10. Ribbon-reverse-detent spring,
50403 | | 30. Ribbon-spool lock |
| 11. Machine screw, 10002 | | 31. Ribbon-sensing lever, 50421A
(lh), 50422A (rh) |

Figure 89. Ribbon-feed mechanism, exploded view.

(2) Remove the two machine screws (1 and 3) and lockwashers (2 and 4) that hold the armature bracket (9) to the teletypewriter frame; remove

the armature bracket.
(3) Remove the setscrew (5) that holds the armature adjustable bushing (6) in the armature bracket (9); remove

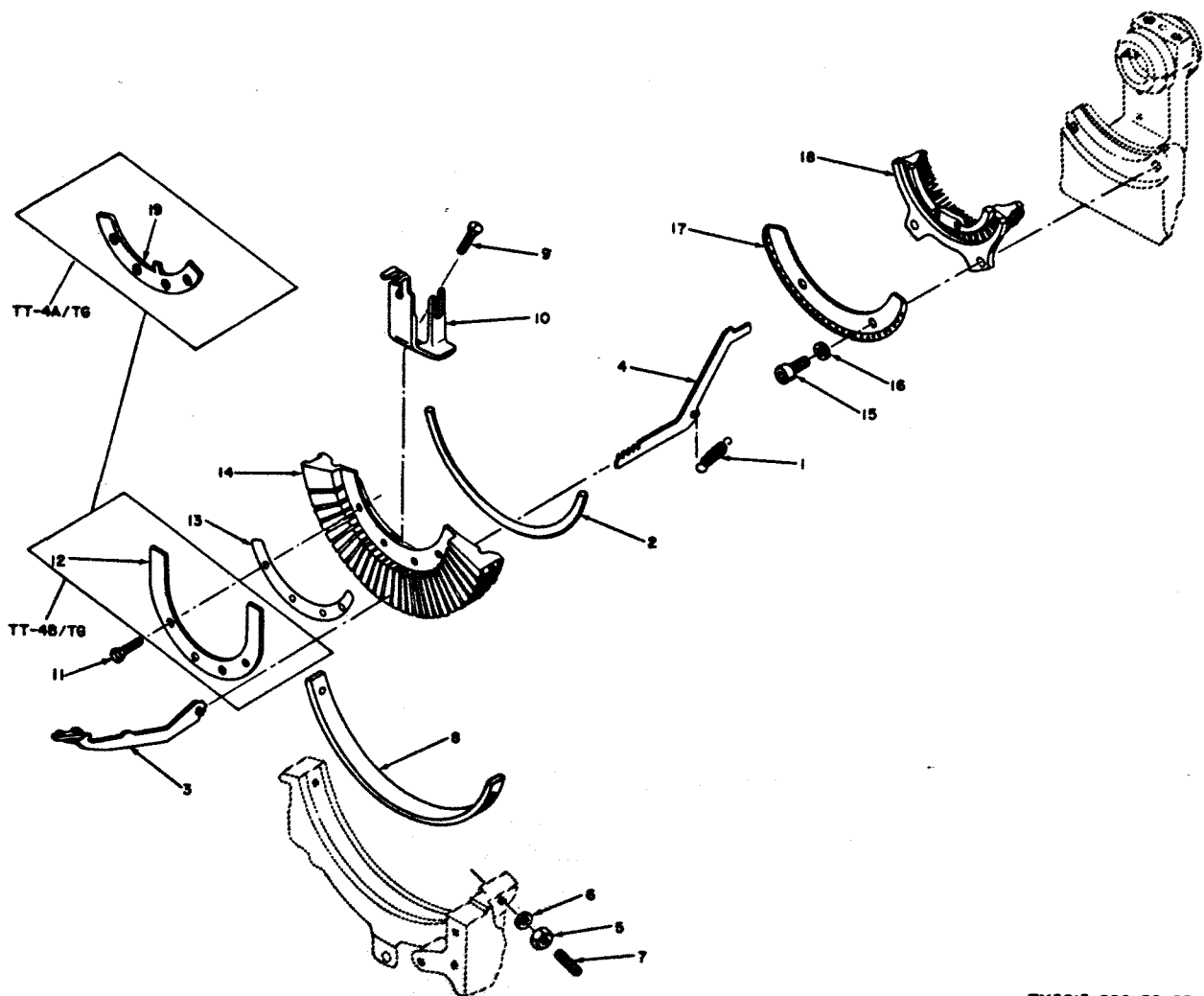

TM5615-206-39-55

- | | | |
|---|--|---------------------------------------|
| 1. Connecting-bar spring, 50595 | 7. Setscrew, 10214 | 13. Bumper-plate shim, 51244 to 51247 |
| 2. Hinge pin, 50572 | 8. Type-bar segment key, 50550 | 14. Type-bar segment, 50549 |
| 3. Type bar. (See type-bar and connecting-bar chart.) | 9. Machine screw, 10306 | 15. Machine screw, 10025 |
| 4. Connecting bar. (See type-bar and connecting-bar chart.) | 10. Ribbon-guide mounting bracket, 50589 ^a , 55147 ^b | 16. Lockwasher, 10430 |
| 5. Plain hexagonal nut, 10509 | 11. Machine screw, 51132 | 17. Mounting plate, 50548 |
| 6. Lockwasher, 10431 | 12. Type-bar bumper plate, 55791 | 18. Guide plate, 50547 |
| | | 19. Type-bar bumper plate, 51181 |

^a Used on TT-4A/TG.

^b Used on TT-4B/TG.

Figure 90. Type-bar group, exploded view.

the armature adjustable bushing, bearing ball (7), and selector-magnet armature (8).

- (4) Unsolder the electrical leads to the switch (13); tag the leads to facilitate reassembly.
- (5) Remove the two machine screws (10) and lockwashers (11) that hold the selector-magnet bracket (20) to the

teletypewriter frame; remove the selector-magnet bracket.

- (6) Remove the plain hexagonal nut (12) that holds the switch (13) to the switch cover (16); remove the switch.
- (7) Remove the two machine screws (14) and lockwashers (15) that hold the switch cover (16) to the selector-mag-

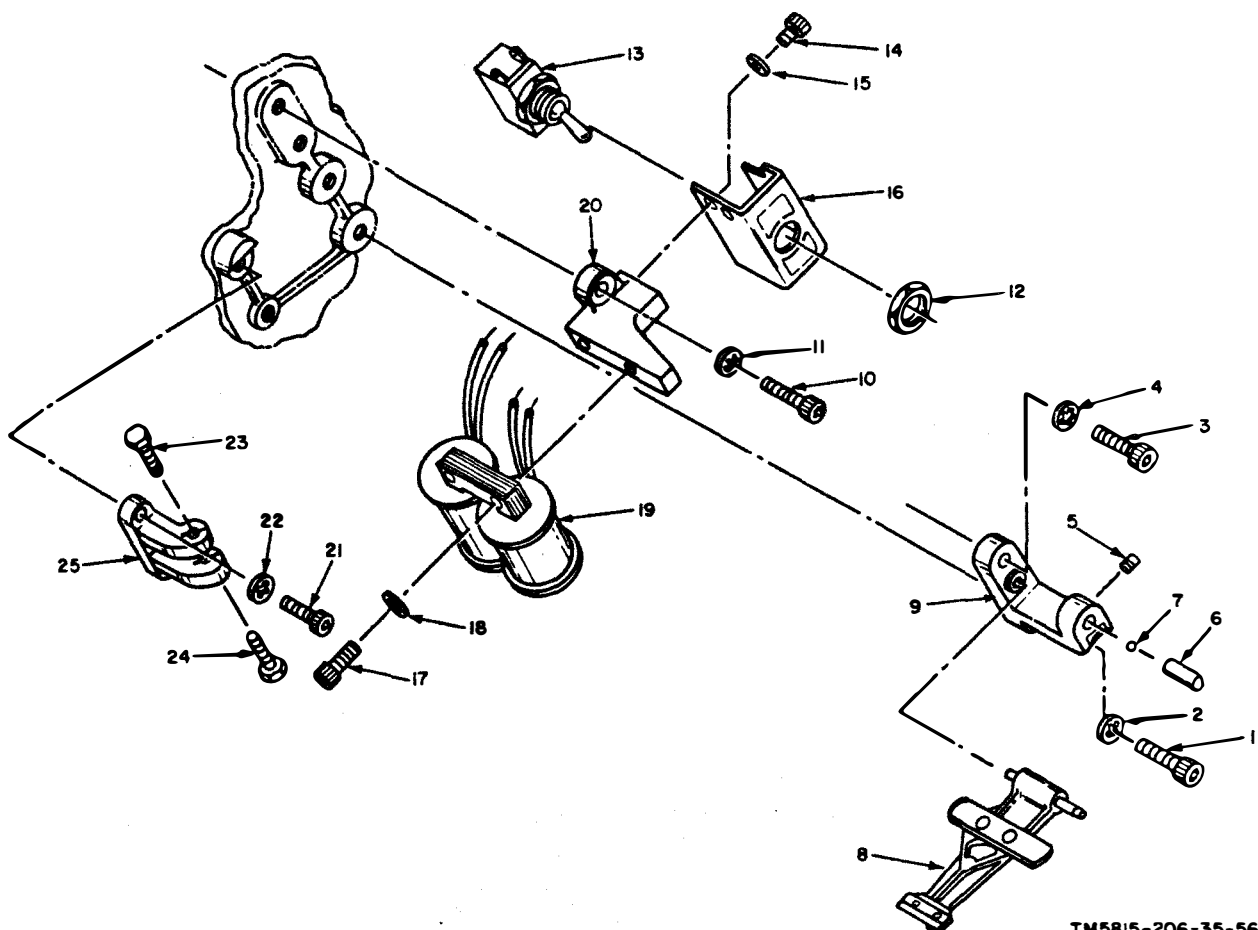

TM5815-206-35-56

- | | | |
|---------------------------------------|---|---|
| 1. Machine screw, 10018 | 9. Armature bracket, 51854 | 18. Lockwasher, 10430 |
| 2. Lockwasher, 10431 | 10. Machine screw, 10011 | 19. Selector-magnet coil assembly, 50271A |
| 3. Machine screw, 10011 | 11. Lockwasher, 10404 | 20. Selector-magnet bracket, 50270 |
| 4. Lockwasher, 10431 | 12. Plain hexagonal nut | 21. Machine screw, 10009 |
| 5. Setscrew, 10203 | 13. Switch S4, 20103 (includes item 12) | 22. Lockwasher, 10430 |
| 6. Armature adjustable bushing, 50310 | 14. Machine screw, 10004 | 23. Stop screw, 10307 |
| 7. Bearing ball, 10924 | 15. Lockwasher, 10429 | 24. Stop screw, 10307 |
| 8. Selector-magnet armature, 51901A | 16. Switch cover, 50994 | 25. Stop-screw bracket, 50504A |
| | 17. Machine screw, 10010 | |

Figure 91. Selector-magnet assembly, exploded view.

- (8) Remove the two machine screws (17) and lockwashers (18) that hold the selector-magnet coil assembly (19) to the selector-magnet bracket (20); remove the selector-magnet coil assembly.
- (9) Remove the two machine screws (21) and lockwashers (22) that hold the stop-screw bracket (25) to the typewriter frame; remove the stop-screw bracket.
- (10) Remove the two stopscrews (23 and

- 24) from the stop-screw bracket (25).
- b. Reassembly.
 - (1) Reassemble the selector-magnet assembly as indicated in figure 91; the sequence for assembling the parts is the reverse of the disassembly sequence.
 - (2) Adjust the selector-magnet assembly (par. 180 through 186).

87. Removal and Replacement of Rangefinder

- a. Removal.
 - (1) Remove the two setscrews (37, fig.

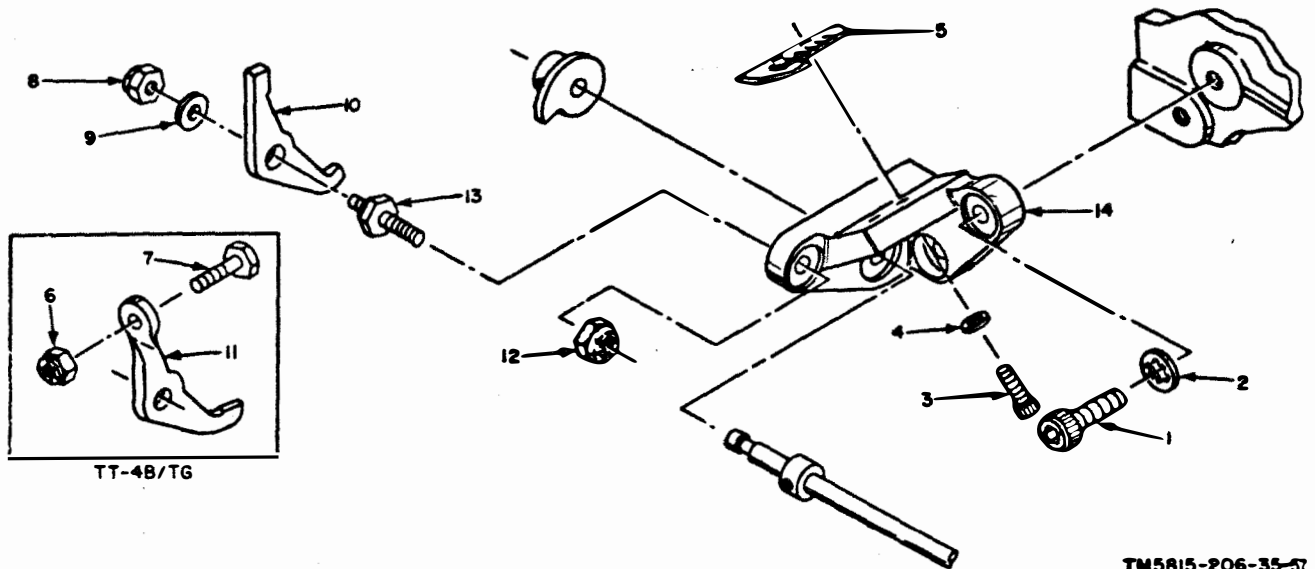

TM5815-206-35-57

- | | | |
|--------------------------------------|--------------------------------------|---|
| 1. Machine screw, 10017 | 7. Machine screw, 10307 | 12. Self-locking hexagonal nut, 10501 |
| 2. Lockwasher, 10405 | 8. Self-locking hexagonal nut, 10500 | 13. Orientation-lever stud, 50330*, 53111* |
| 3. Machine screw, 10004 | 9. Flat washer, 50414 | 14. Selector-lever-comb bracket, 50510A*, 57709A* |
| 4. Lockwasher 10403 | 10. Orientation lever 50324* | |
| 5. Selector-lever comb, 50511 | 11. Orientation lever 53112 | |
| 6. Self-locking hexagonal nut, 10500 | | |

* Used on TT-4A/TG.

* Used on TT-4B/TG.

Figure 92. Selector-lever-comb bracket assembly, exploded view.

80) that hold the rangefinder cam (38) to the rangefinder shaft (43); remove the rangefinder cam.

- (2) Loosen the two setscrews (41) that hold the rangefinder gear (42) to the rangefinder shaft (43); slide the rangefinder shaft forward to disengage the selector-lever-comb bracket (14, fig. 92).
- (3) Remove the two machine screws (1) and lockwashers (2) that hold the assembly to the teletypewriter frame; remove the rangefinder.

b. Replacement.

- (1) Replace the rangefinder by reversing the procedure described in *a* above.
- (2) Adjust the rangefinder (par. 176, 178, and 179).

88. Disassembly and Reassembly of Rangefinder (fig. 92)

a. Disassembly.

- (1) Remove the rangefinder from the teletypewriter (par. 87a).
- (2) Remove the two machine screws (3)

and lockwashers (4) that hold the selector-lever comb (5) to the selector-lever-comb bracket (14); remove the selector-lever comb.

- (3) On the TT-4B/TG, remove the self-locking hexagonal nut (6) that holds the machine screw (7) securely in the orientation lever (11); remove the machine screw.
- (4) Remove the self-locking hexagonal nut (8) and flat washer (9) that hold the orientation lever (10 or 11) to the orientation-lever stud (13); remove the orientation lever.
- (5) On the TT-4A/TG, remove the self-locking hexagonal nut (12) that holds the orientation-lever stud (13) to the selector-lever-comb bracket (14); remove the orientation-lever stud.
- (6) On the TT-4B/TG, remove the orientation-lever stud (13) from the selector-lever-comb bracket (14).

b. Reassembly.

- (1) Reassemble the rangefinder as indicated in figure 92; the sequence for as-

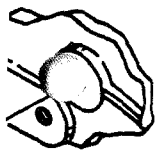

sembling the parts is the reverse of the disassembly sequence.

- (2) Replace the rangefinder (par. 87b).
- (3) Adjust the rangefinder cam follower (par. 177).

89. Disassembly and Reassembly of Selector Levers and Y-levers (TT-4A/TG) (fig. 93)

a. Disassembly.

- (1) Remove the six selector-lever springs (1) from the spring post (2) and from the stop lever (22) and five selector levers (19).
- (2) Remove the plain hexagonal nut (3) from the spring post (2) and unscrew the spring post from the teletypewriter frame.
- (3) Remove the two setscrews (4) that hold the spacing collar (5) on the Y-lever stud (38); remove the collar and the friction-plate spring (6).
- (4) Remove the six friction plates (7, 9, 11, 13, 15, and 17), five Y-levers (8, 10, 12, 14, and 16), and collar (18) from the Y-lever stud (38).
- (5) Remove the set of five selector levers (19) from the five bearings (24, 26, 28, 30, and 32).
- (6) Remove the self-locking hexagonal nut (20), stop-lever eccentric bearing (21), stop lever (22), and stop-lever spacer (23) from the selector-lever stud (36).
- (7) Remove the five bearings (24, 26, 28, 30, and 32), four flat washers (25, 27, 29, and 31) and collar (33) from the selector-lever stud (36).
- (8) Remove the Y-lever friction-plate stud (34) from the teletypewriter frame.
- (9) Remove the setscrew (35) that holds the selector-lever stud (36) in the teletypewriter frame; remove the selector-lever stud.
- (10) Remove the setscrew (37) that holds the Y-lever stud (38) in the teletypewriter frame; remove the Y-lever stud.
- (11) Remove the setscrew (39) that holds the Y-lever eccentric stop (40) in the teletypewriter frame; remove the Y-lever eccentric stop.

b. Reassembly.

- (1) Reassemble the selector levers and Y-levers as indicated in figure 93; the sequence for assembling the parts is the reverse of the disassembly sequence.

Note. When replacing either selector levers or Y-levers, replace an entire set. Do not use a combination of new and old levers.

- (2) Adjust the selector levers and Y-levers (par. 173, 178, and 182).

90. Disassembly and Reassembly of Selector Levers and Y-levers (TT-4B/TG) (fig. 94)

a. Disassembly.

- (1) Remove the six selector-lever springs (1) from the spring post (2) and from the five selector levers (38) and the stop lever (41).
- (2) Remove the plain hexagonal nut (3) from the spring post (2) and unscrew the spring post from the frame.
- (3) Remove the five Y-lever detent springs (4) from the five Y-lever detents (9, 11, 13, 15, and 18) and from the detent-spring bracket (54).
- (4) Remove the plain hexagonal nut (5), lockwasher (6), and centering sleeve (7) from the detent stud (53). Remove the thrust washers (8, 10, 12, 14, and 16) and five Y-lever detents (9, 11, 13, 15, and 18) alternately and the flat washer (17) from the centering sleeve (7).
- (5) Remove the detent stud (53) and the detent-spring bracket (54) from the frame.
- (6) Remove the machine screw (19), flat washer (20), and clamp nut (21) that hold the Y-lever stud bracket (26) to the Y-lever stud (58); remove the Y-lever stud bracket from the Y-lever stud and the Y-lever eccentric stop (60).
- (7) Remove the two machine screws (22), lockwashers (23), and flat washers (24) that hold the Y-lever eccentric tie (25) to the Y-lever-stud bracket (26); remove the Y-lever eccentric tie.
- (8) Remove the spacer (27), five Y-levers (28, 30, 32, 34, and 36), four flat wash-

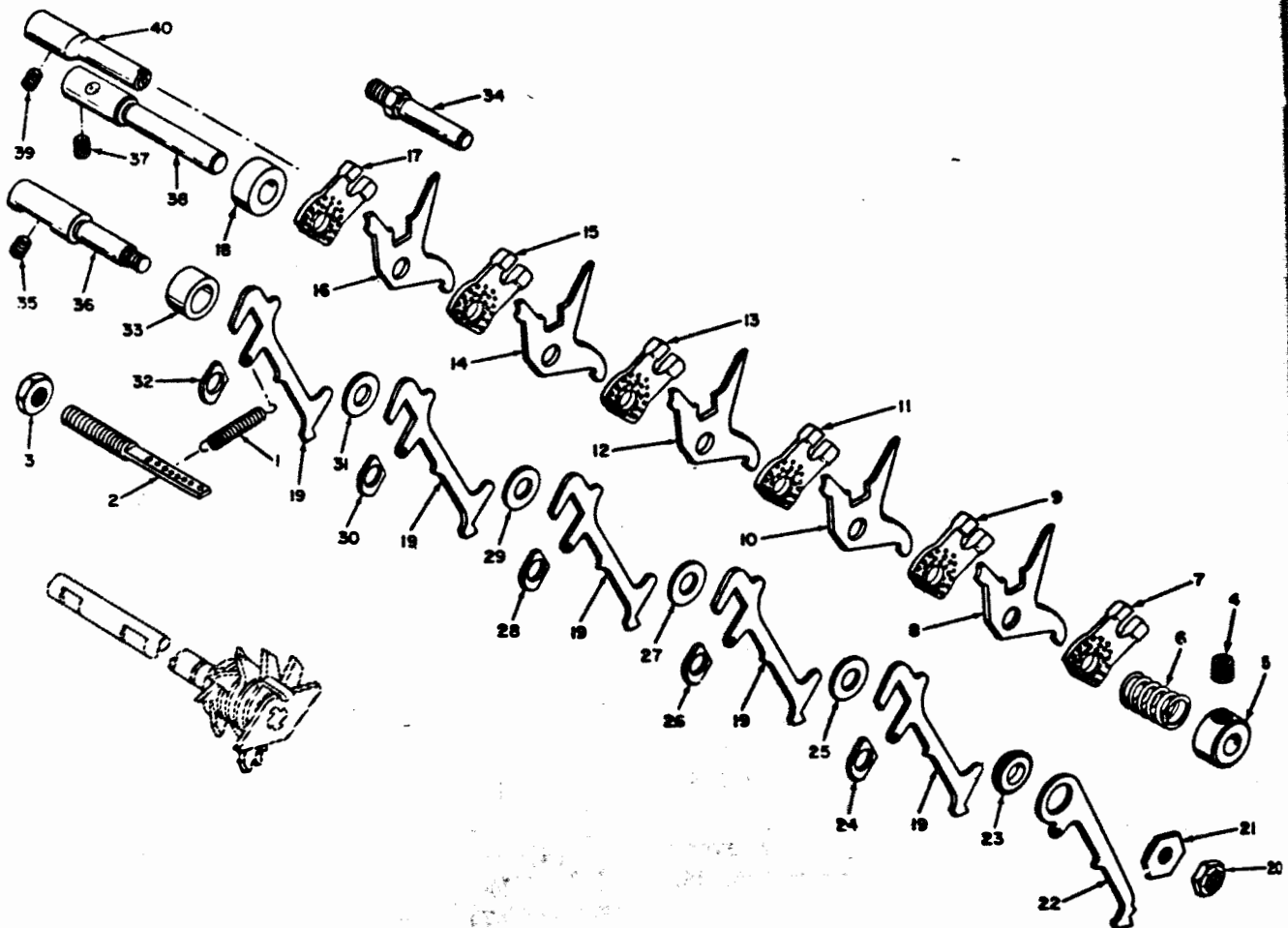

TM5815-206-35-56

- | | | |
|---------------------------------|--|--|
| 1. Selector-lever spring, 50902 | 16. Y-lever, 50015 | 26. Bearing |
| 2. Spring post, 50325 | 17. Friction plate, 50818 | 27. Flat washer, 50147 |
| 3. Plain hexagonal nut, 10509 | 18. Collar, 50414 | 28. Bearing |
| 4. Setscrew, 10209 | 19. Selector lever, 51068A (consists of set of 5) | 29. Flat washer, 50147 |
| 5. Spacing collar, 50149 | 20. Self-locking hexagonal nut, 10500 | 30. Bearing |
| 6. Friction-plate spring, 50910 | 21. Stop-lever eccentric bearing, 50146 | 31. Flat washer, 50147 |
| 7. Friction plate, 50818 | 22. Stop lever, 50014 | 32. Bearing |
| 8. Y-lever, 50015 | 23. Stop-lever spacer, 50053 | 33. Collar, 51416 |
| 9. Friction plate, 50818 | 24. Bearing, 51604A (consists of set of 5, items 24, 26, 28, 30, and 32) | 34. Y-lever friction-plate stud, 50151 |
| 10. Y-lever, 50015 | 25. Flat washer, 50147 | 35. Setscrew, 10211 |
| 11. Friction plate, 50818 | | 36. Selector-lever stud, 53268 |
| 12. Y-lever, 50015 | | 37. Setscrew, 10211 |
| 13. Friction plate, 50818 | | 38. Y-lever stud, 53269 |
| 14. Y-lever, 50015 | | 39. Setscrew, 10211 |
| 15. Friction plate, 50818 | | 40. Y-lever eccentric stop, 50152 |

Figure 28. Selector levers and Y-levers (TT-4A/TG), exploded view.

- ers (29, 31, 33, and 35), and collar (37) from the Y-lever stud (58).
- (9) Remove the five selector levers (38) from the bearings (43, 45, 47, 49, and 51).
- (10) Remove the self-locking hexagonal nut (39), stop-lever eccentric bearing (40), stop lever (41), and stop-lever spacer (42) from the selector-lever pivot stud (56).
- (11) Remove the five bearings (43, 45, 47, 49, and 51), four flat washers (44, 46, 48, and 50), and collar (52) from the selector-lever pivot stud (56).
- (12) Remove the setscrew (55) that holds the selector-lever pivot stud (56) in the frame; remove the selector-lever pivot stud.
- (13) Remove the setscrew (57) that holds

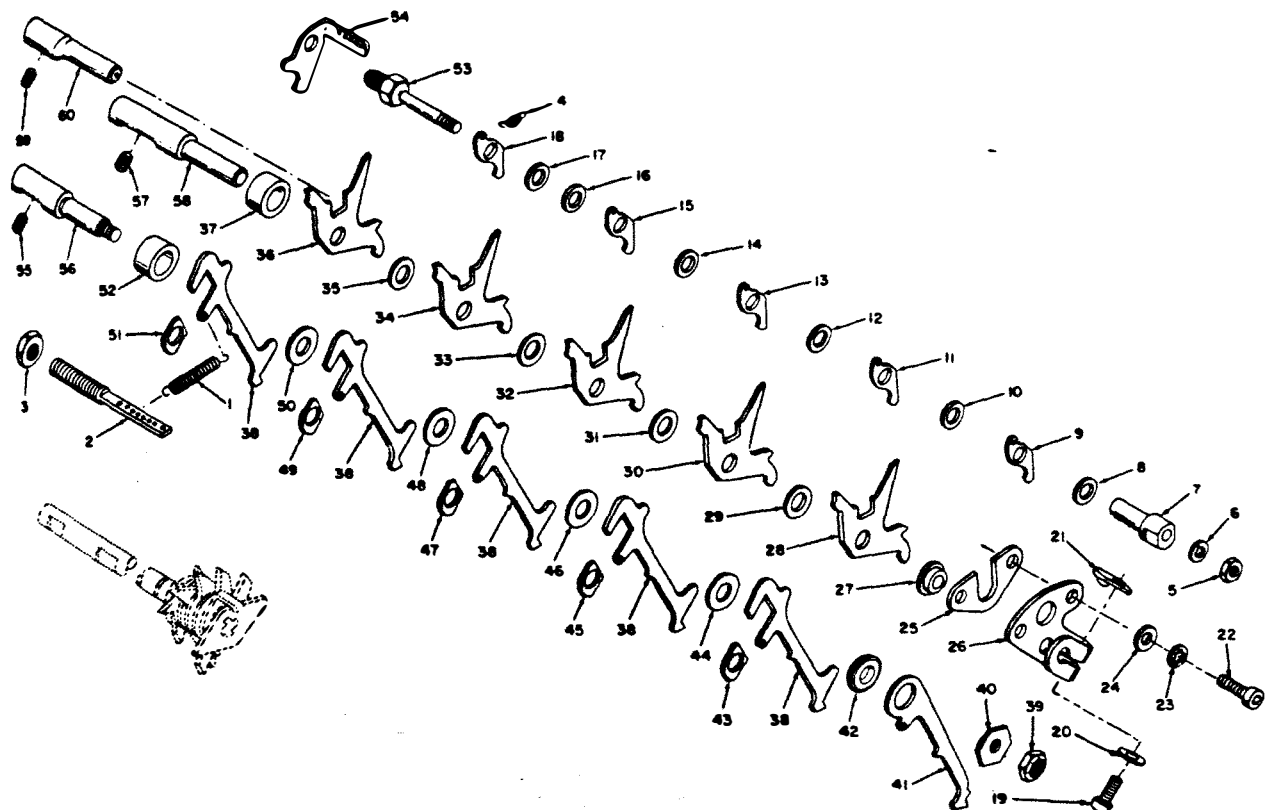

TM5815-206-35-59

- | | | |
|---|---|--|
| 1. Selector-lever spring, 50902 | 21. Clamp nut, 50174 | 41. Stop lever, 50014 |
| 2. Spring post, 50325 | 22. Machine screw, 10002 | 42. Stop-lever spacer, 50053 |
| 3. Plain hexagonal nut, 10509 | 23. Lockwasher, 10403 | 43. Bearing, 51604A (consists of set of 5, items 43, 45, 47, 49, and 51) |
| 4. Y-lever-detent spring, 61000 | 24. Flat washer, 50319 | 44. Flat washer, 50147 |
| 5. Plain hexagonal nut, 10504 | 25. Y-lever eccentric tie, 60678 | 45. Bearing |
| 6. Lockwasher, 10434 | 26. Y-lever stud bracket, 60677 | 46. Flat washer, 50147 |
| 7. Centering sleeve, 55007 | 27. Spacer, 60679 | 47. Bearing |
| 8. Thrust washer, 55001 | 28. Y-lever, 55003 | 48. Flat washer, 50147 |
| 9. Y-lever detent, 55004A (consists of set of 5, items 9, 11, 13, 15, and 18) | 29. Flat washer, 50148 | 49. Bearing |
| 10. Thrust washer, 55001 | 30. Y-lever, 55003 | 50. Flat washer, 50147 |
| 11. Y-lever detent | 31. Flat washer, 50148 | 51. Bearing |
| 12. Thrust washer, 55001 | 32. Y-lever, 55003 | 52. Collar, 51416 |
| 13. Y-lever detent | 33. Flat washer, 50148 | 53. Detent stud, 55008 |
| 14. Thrust washer, 55001 | 34. Y-lever, 55003 | 54. Detent-spring bracket, 55002 |
| 15. Y-lever detent | 35. Flat washer, 50148 | 55. Setscrew, 10211 |
| 16. Thrust washer, 55001 | 36. Y-lever, 55003 | 56. Selector-lever pivot stud, 53268 |
| 17. Flat washer, 55076 | 37. Collar, 51416 | 57. Setscrew, 10211 |
| 18. Y-lever detent | 38. Selector lever, 51068A (consists of set of 5) | 58. Y-lever stud, 53269 |
| 19. Machine screw, 10006 | 39. Self-locking hexagonal nut, 10500 | 59. Setscrew, 10211 |
| 20. Flat washer, 10459 | 40. Stop-lever eccentric bearing, 55024 | 60. Y-lever eccentric stop, 61001 |

Figure 94. Selector levers and Y-levers (TT-4B/TG), exploded view.

the Y-lever stud (58) in the frame; remove the Y-lever stud.

- (14) Remove the setscrew (59) that holds the Y-lever eccentric stop (60) in the frame; remove the Y-lever eccentric stop.

b. Reassembly.

- (1) Reassemble the selector levers and

Y-levers as indicated in figure 94; the sequence for assembling the parts is the reverse of the disassembly sequence.

Note. When replacing either selector levers or Y-levers, replace an entire set. Do not use a combination of new and old levers.

- (2) Adjust the selector levers and Y-levers (par. 173, 178, and 182).

**91. Disassembly and Reassembly of
Transfer-Lever Shaft Assembly
(fig. 95)**

a. Disassembly.

- (1) Remove one paper-shaft bracket and the paper chute (par. 58a).
- (2) On the TT-4A/TG, remove the transfer-lever spring (1) from the spring stud (35) and from the spring post on the frame.
- (3) On the TT-4B/TG, remove the transfer-lever spring (1) from the spring stud (35) and from the eccentric spring post (52).
- (4) Remove the self-locking hexagonal nut (2), flat washer (3), and shim (4) that hold the five T-levers (5, 7, 9, 11, and 13) and four flat washers (6, 8, 10, and 12) to the T-lever pivot stud (16); alternately remove the T-levers and flat washers.
- (5) Remove the machine screw (17) that holds the clutch latch (22) to the transfer-lever shaft assembly (42); remove the assembled clutch latch and ball bearing (21).
- (6) Remove the plain hexagonal nut (18), lock washer (19), and machine screw (20) that hold the ball bearing (21) to the clutch latch (22); remove the ball bearing.
- (7) On the TT-4A/TG, remove the two setscrews (23) that hold the shaft collar (24) to the transfer-lever shaft assembly (42); remove the shaft collar.
- (8) Remove the four setscrews (25 and 26) that hold the two shaft collars (27 and 28) to the transfer-lever shaft assembly (42).
- (9) Pull the transfer-lever shaft assembly (42) from the frame; catch the two shaft collars (27 and 28) as they fall from the shaft.
- (10) On the TT-4B/TG, remove the machine screw (29) that holds the shaft collar (30) to the transfer-lever shaft assembly (42); remove the shaft collar.
- (11) Remove the two machine screws (31 and 32) that hold the two shaft collars (33 and 34) to the transfer-lever shaft assembly (42).
- (12) Pull the transfer-lever shaft assembly (42) from the frame; catch the two shaft collars (33 and 34) as they fall from the shaft.
- (13) Remove the plain hexagonal nut (14) and lockwasher (15) that hold the T-lever pivot stud (16) to the transfer-lever shaft assembly (42); remove the T-lever pivot stud.
- (14) Remove the spring stud (35) from the transfer-lever shaft assembly (42).
- (15) On the TT-4A/TG, remove the self-locking hexagonal nut (36) that holds the assembled transfer-lever-roller stud (items 37 through 40) to the transfer-lever shaft assembly (42); remove the assembled transfer-lever-roller stud. Remove the plain hexagonal nut (37) and lockwasher (38) that hold the ball bearing (39) to the transfer-lever-roller stud (40); remove the ball bearing.
- (16) On the TT-4B/TG, remove the self-locking hexagonal nut (36) that holds the transfer-lever-roller stud assembly (41) to the transfer-lever shaft assembly (42); remove the transfer-lever-roller stud assembly.
- (17) Remove the transfer-lever-latch spring (43) from the transfer-lever latch (47) and from the spring post.
- (18) On the TT-4A/TG, remove the cotter pin (44) and flat washer (45) that hold the transfer-lever latch (47) to the transfer-lever-latch stud (48); remove the transfer-lever latch.
- (19) On the TT-4B/TG, remove the retainer ring (46) that holds the transfer-lever latch (47) to the transfer-lever-latch stud (48); remove the transfer-lever latch.
- (20) Remove the transfer-lever-latch stud (48) from the frame.
- (21) On the TT-4B/TG, remove the machine screw (49), lockwasher (50), and flat washer (51) that hold the eccentric spring post (52) in the frame; remove the eccentric spring post.

transfer-lever shaft assembly. Match the two transfer-lever shafts as they fall into place. Tighten the lock nut (14) to hold the transfer-lever shaft in place; remove the transfer-lever shaft (35) from the transfer-lever shaft assembly. Remove the self-locking nut (14) that holds the transfer-lever-roller stud assembly (42) to the transfer-lever shaft (35); remove the plain hexagonal nut (10504) (39) to the transfer-lever-roller stud (40); re-

move the self-locking nut (14) that holds the transfer-lever-roller stud assembly (42) to the transfer-lever shaft (35). Remove the cotter pin (45) that holds the transfer-lever latch (47) to the transfer-lever shaft (48); re-

move the transfer-lever latch stud (48) from the transfer-lever shaft (48). Remove the machine screw (50), and remove the eccentric spring post (52) from the frame; re-

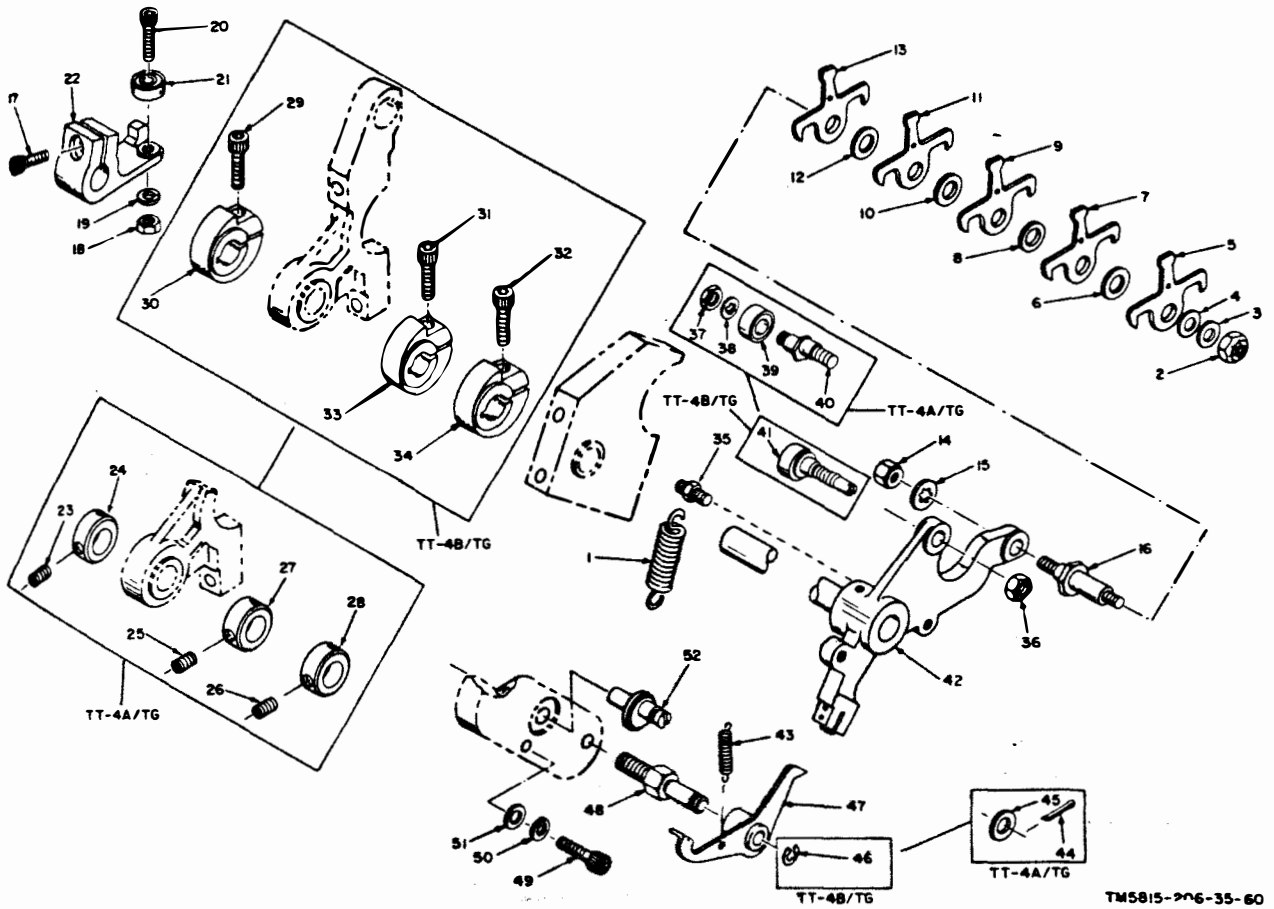

- | | | |
|--|---|---|
| 1. Transfer-lever spring, 50903 | 18. Plain hexagonal nut, 10504 | 37. Plain hexagonal nut, 10504 |
| 2. Self-locking hexagonal nut, 10500 | 19. Lockwasher, 10434 | 38. Lockwasher, 10402 |
| 3. Flat washer, 50414 | 20. Machine screw, 10000 | 39. Ball bearing, 10754 |
| 4. Shim (.002-in.), 57072, or Shim (.003-in.), 57073 | 21. Ball bearing, 10754 | 40. Transfer-lever-roller stud, 50537 |
| 5. T-lever, 51066A (consists of set of 5, items 5, 7, 9, 11, and 13) | 22. Clutch latch, 50535A (includes items 17 through 22) | 41. Transfer-lever-roller stud assembly, 56185A |
| 6. Flat washer, 50148 | 23. Setscrew, 10209 | 42. Transfer-lever shaft assembly, 50645A*, 52394A* |
| 7. T-lever | 24. Shaft collar, 50327 | 43. Transfer-lever-latch spring, 50904 |
| 8. Flat washer, 50148 | 25. Setscrew, 10209 | 44. Cotter pin, 10801 |
| 9. T-lever | 26. Setscrew, 10209 | 45. Flat washer, 50351 |
| 10. Flat washer, 50148 | 27. Shaft collar, 50327 | 46. Retainer ring, 10949 |
| 11. T-lever | 28. Shaft collar, 50327 | 47. Transfer-lever latch, 50020A |
| 12. Flat washer, 50148 | 29. Machine screw, 10010 | 48. Transfer-lever-latch stud, 50220*, 52319* |
| 13. T-lever | 30. Shaft collar, 53973 | 49. Machine screw, 10003* |
| 14. Plain hexagonal nut, 50651 | 31. Machine screw, 10010 | 50. Lockwasher, 10429* |
| 15. Lockwasher, 10404 | 32. Machine screw, 10010 | 51. Flat washer, 50839* |
| 16. T-lever pivot stud, 50650 | 33. Shaft collar, 53973 | 52. Eccentric spring post, 56076* |
| 17. Machine screw, 10008 | 34. Shaft collar, 53973 | |
| | 35. Spring stud, 50649 | |
| | 36. Self-locking hexagonal nut, 10501 | |

* Used on TT-4A/TG.

* Used on TT-4B/TG.

Figure 95. Transfer-lever shaft assembly, exploded view.

b. Reassembly.

(1) Reassemble the transfer-lever shaft assembly as indicated in figure 95; the sequence for assembling the parts is the reverse of the disassembly sequence.

(2) Replace the paper-shaft bracket and paper chute on the frame (par. 58b).
 (3) Adjust the transfer-lever shaft assembly (pars. 161 through 164, 166, and 168 through 170).

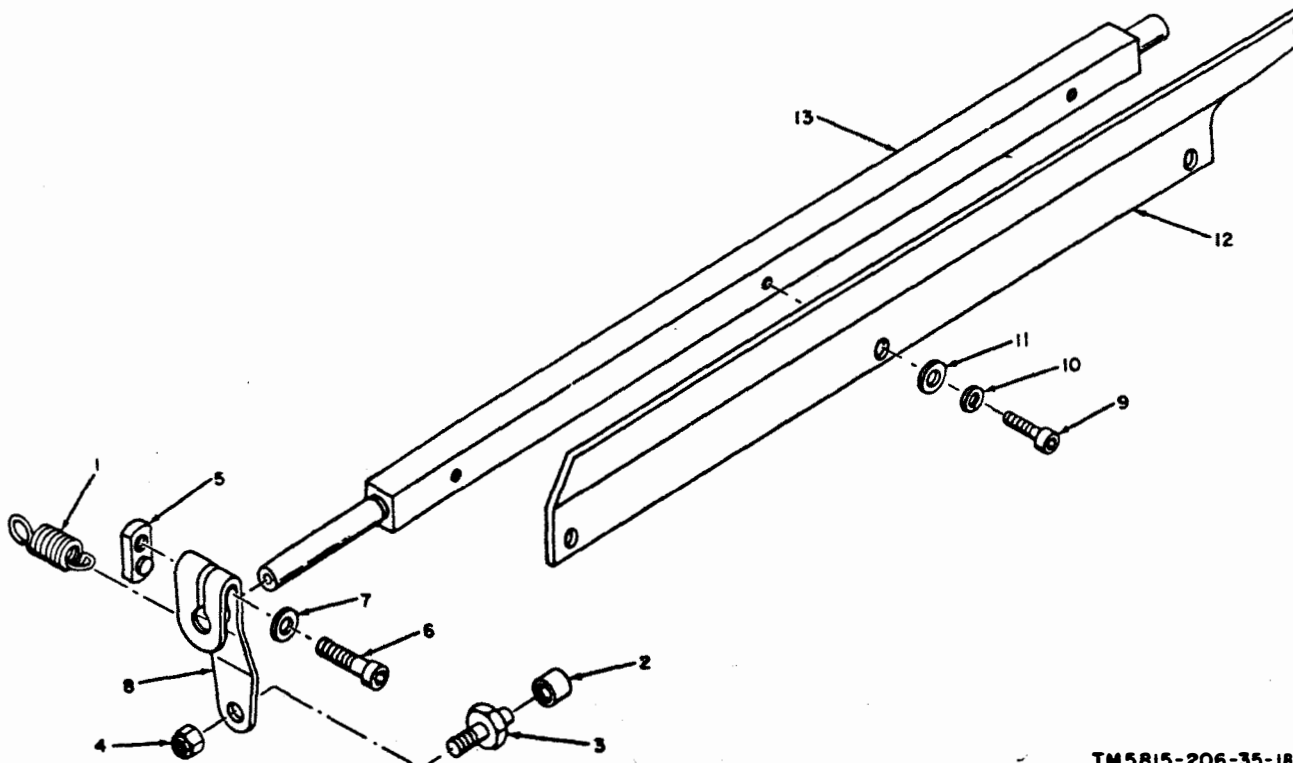

TM5815-206-35-189

- | | | |
|--|----------------------------------|-----------------------------|
| 1. Print-cam-follower spring, 50921 | 5. Clamp nut, 50174 | 10. Lockwasher, 10429 |
| 2. Bushing, 50943 | 6. Machine screw, 10006*, 10046* | 11. Flat washer, 10450 |
| 3. Print-cam-follower-roller stud, 50886 | 7. Flat washer, 10459 | 12. Print-bail blade, 50533 |
| 4. Self-locking hexagonal nut, 10501 | 8. Print-cam follower, 50948 | 13. Print-bail shaft, 50534 |
| | 9. Machine screw, 10004 | |

* Used on TT-4A/TG.

* Used on TT-4B/TG.

Figure 96. Print-bail shaft assembly, exploded view.

92. Disassembly and Reassembly of Print-Bail Shaft Assembly (fig. 96)

a. Disassembly.

- (1) Remove one paper-shaft bracket and the paper chute (par. 58a).
- (2) Remove the transfer-lever shaft assembly from the teletypewriter (par. 91a).
- (3) Remove the two setscrews (41, fig. 102) that hold the print cam (42) to the function shaft (46). Slide the print cam to the selector side of the teletypewriter. Be careful not to lose the bushing (2, fig. 96) from the print-cam-follower-roller stud (3).
- (4) Remove the print-cam-follower spring (1) from the print-cam follower (8) and from the spring post on the teletypewriter frame.
- (5) Remove the two machine screws (3 and 5, fig. 102) and lockwashers (4 and 6) that hold the middle bearing cap to the frame assembly; remove the middle bearing cap by sliding it to the selector side.
- (6) Remove the assembled print-bail-shaft (13, fig. 96), print-bail blade (12), and print-cam follower (8) by moving the shaft to the selector side.
- (7) Remove the bushing (2), print-cam-follower-roller stud (3), and self-locking hexagonal nut (4) from the print-cam follower (8).
- (8) Remove the clamp nut (5), machine screw (6), and flat washer (7) that hold the print-cam follower (8) to the print-bail shaft (13); remove the print-cam follower.
- (9) Remove the three machine screws (9),

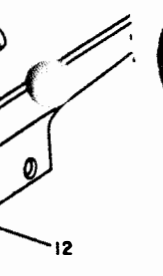

lockwashers (10), and flat washers (11) that hold the print-bail blade (2) to the print-bail shaft (13); remove the print-bail blade.

b. Reassembly.

- (1) Reassemble the print-bail shaft as indicated in figure 96; the sequence for assembling the parts is the reverse of the disassembly sequence.
- (2) Replace the transfer-lever shaft assembly (par. 91b).
- (3) Adjust the print-bail shaft (pars. 226 and 227).
- (4) Replace the paper-shaft bracket and paper chute (par. 58b).

93. Disassembly and Reassembly of Signal-Bell Assembly
(fig. 97)

a. Disassembly.

- (1) Remove the two machine screws (1) and lockwashers (2) that hold the signal-bell assembly to the frame; remove the assembly by sliding it downward until the signal-bell clapper (13) and the motor-stop actuating lever (18) are clear of their punch bars (37 and 38, fig. 98).
- (2) Remove the self-locking hexagonal nut (3, fig. 97) that holds the signal bell (4) to the machine screw (6); remove the signal bell.
- (3) On the TT-4A/TG, remove the self-locking hexagonal nut (5), machine screw (6), and lockwasher (7) that hold the signal-bell clapper stop (8) to the signal-bell bracket (19); remove the signal-bell clapper stop.
- (4) On the TT-4B/TG, remove the self-locking hexagonal nut (5) and machine screw (6) that hold the signal-bell clapper stop (8) to the signal-bell bracket (19); remove the signal-bell clapper stop.
- (5) Remove the signal-bell-clapper spring (9) from the signal-bell clapper (13) and from the signal-bell bracket (19).
- (6) On the TT-4A/TG, remove the cotter pin (10) and flat washer (11) that hold the signal-bell clapper (13) to the stud on the signal-bell bracket (19); remove the signal-bell clapper.

- (7) On the TT-4B/TG, remove the retainer ring (12) that holds the signal-bell clapper (13) to the stud on the signal-bell bracket (19); remove the signal-bell clapper.
- (8) Remove the motor-stop actuating-lever spring (14) from the motor-stop actuating lever (18) and from the spring post on the signal-bell bracket (19).
- (9) On the TT-4A/TG, remove the cotter pin (15) and flat washer (16) that hold the motor-stop actuating lever (18) to the stud on the signal-bell bracket (19); remove the motor-stop actuating lever.
- (10) On the TT-4B/TG, remove the retainer ring (17) that holds the motor-stop actuating lever (18) to the stud on the signal-bell bracket (19); remove the motor-stop actuating lever.

b. Reassembly.

- (1) Reassemble the signal-bell assembly as indicated in figure 97; the sequence for assembling the parts is the reverse of the disassembly sequence.
- (2) Adjust the signal-bell assembly (pars. 260 through 262).

94. Disassembly and Reassembly of Function-Selecting Mechanism
(fig. 98)

a. Disassembly.

- (1) Remove the manual carriage-return button (1, fig. 109) from the end of the manual carriage-return link (4).
- (2) Remove the two machine screws (1, fig. 98) and lock washers (2) that hold the function bracket (30) to the function side of the frame.
- (3) On the TT-4A/TG, remove the cotter pin (3) and flat washer (4) that hold the carriage-feed link (4, fig. 110) to the stud on the carriage-feed lever (26, fig. 98); remove the carriage-feed link from the carriage-feed lever. Remove the function bracket mechanism from the frame; be careful to disengage the cam-follower roller (15) from the function cam (44 fig. 102), the function-cam follower (19, fig. 98) from the function-selecting arm (1,

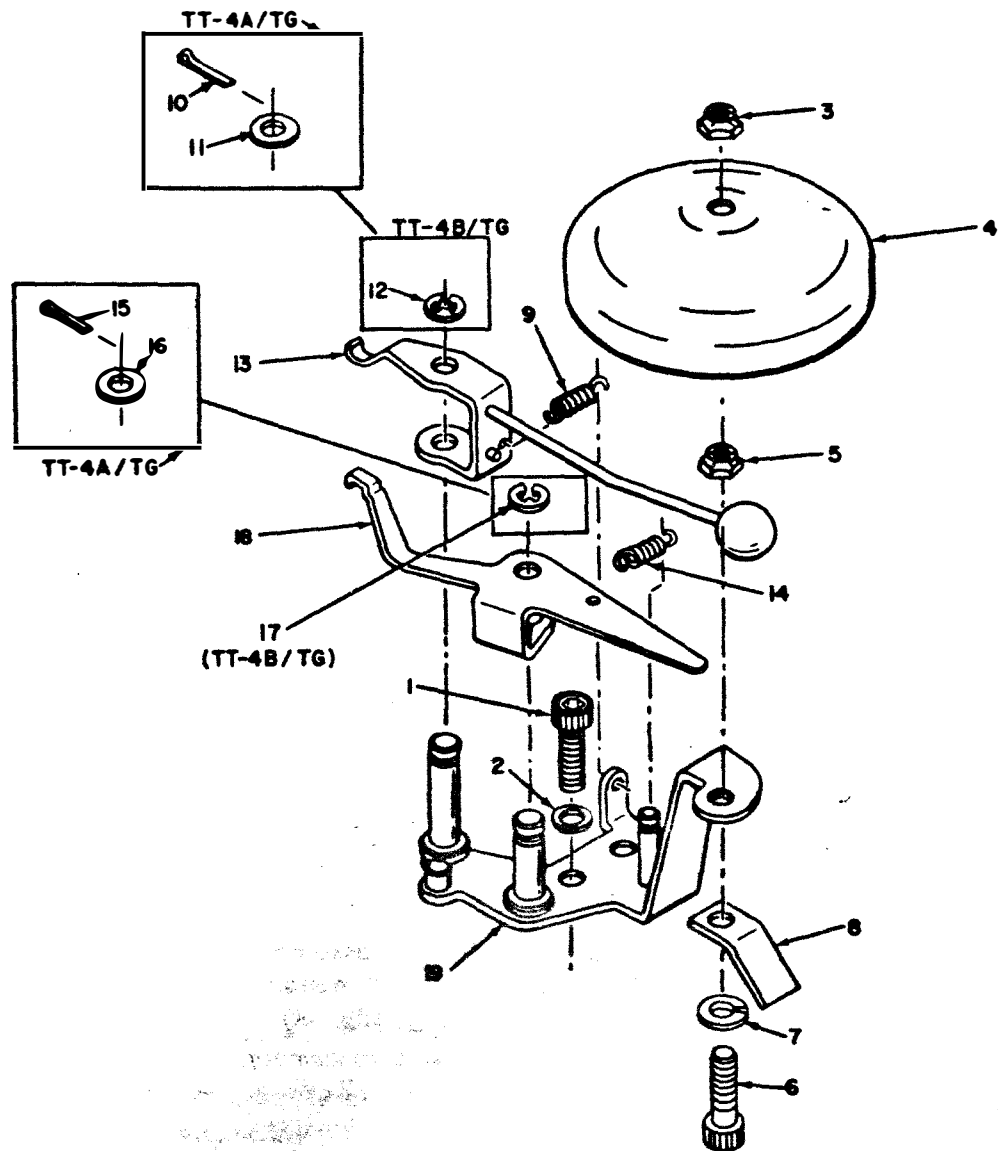

TM5815-206-35-61

- | | | |
|--------------------------------------|--------------------------------------|--|
| 1. Machine screw, 10008 | 7. Lockwasher, 10404* | 14. Motor-stop actuating-lever spring, 50919 |
| 2. Lockwasher, 10404*, 10403* | 8. Signal-bell clapper stop, 51102 | 15. Cotter pin, 10801 |
| 3. Self-locking hexagonal nut, 10501 | 9. Signal-bell-clapper spring, 50920 | 16. Flat washer, 50315 |
| 4. Signal bell, 51080 | 10. Cotter pin, 10801 | 17. Retainer ring, 10949 |
| 5. Self-locking hexagonal nut, 10501 | 11. Flat washer, 50315 | 18. Motor-stop actuating lever, 50874 |
| 6. Machine screw, 10010 | 12. Retainer ring, 10949 | 19. Signal-bell bracket, 50867*, 53157A* |
| | 13. Signal-bell clapper, 50879A | |

* Used on TT-4A/TG.

* Used on TT-4B/TG.

Figure 97. Signal-bell assembly, exploded view.

fig. 101), and the function bracket (30, fig. 98) from the manual carriage-return link (4, fig. 109).

- (4) On the TT-4B/TG, remove the retainer ring (5, fig. 98) that holds the carriage-feed link (4, fig. 110) to the

stud on the carriage-feed lever (26, fig. 98); remove the carriage-feed link from the carriage-feed lever. Remove the function bracket mechanism from the frame; be careful to disengage the cam-follower roller (15) from the

- function cam (44, fig. 102), the function-cam follower (19, fig. 98) from the function-selecting arm (1, fig. 101), and the function bracket (30, fig. 98) from the manual carriage-return link (4, fig. 109).
- (5) Remove the platen-latch spring (6, fig. 98) from the platen latch (10) and from the spring post on the function bracket (30).
 - (6) On the TT-4A/TG, remove the cotter pin (7) and flat washer (8) that hold the platen latch (10) to the stud on the function bracket (30); remove the platen latch.
 - (7) On the TT-4B/TG, remove the retainer ring (9) that holds the platen latch (10) to the stud on the function bracket (30); remove the platen latch.
 - (8) Remove the support-lever spring (11) from the support lever (22) and from the spring post on the function bracket (30).
 - (9) On the TT-4A/TG, remove the cotter pin (12) and the pin (14) that hold the assembled function-cam follower and support lever to the function bracket (30); remove the assembled function-cam follower and support lever.
 - (10) On the TT-4B/TG, remove the retainer ring (13) and pin (14) that hold the assembled function-cam follower and support lever to the function bracket (30); remove the assembled function-cam follower and support lever.
 - (11) Remove the cam-follower roller (15) from the function-cam follower (19).
 - (12) On the TT-4A/TG, remove the cotter pin (16) and flat washer (17) that hold the function-cam follower (19) on the function-cam-follower stud (21); remove the function-cam follower.
 - (13) On the TT-4B/TG, remove the retainer ring (18) that holds the function-cam follower (19) on the function-cam-follower stud (21); remove the function-cam follower.
 - (14) Remove the self-locking hexagonal nut (20) that holds the function-cam-follower stud (21) to the support lever (22); remove the function-cam-follower stud.
 - (15) On the TT-4A/TG, remove the two setscrews (23) that hold the shaft collar (25) to the pivot (24); remove the pivot from the function bracket (30) and catch the shaft collar, carriage-feed lever (26), spacer (27), and unshift lever (28) as they fall from the pivot.
 - (16) On the TT-4B/TG, remove the two setscrews (23) that hold the shaft collar (25) to the pivot (24); remove the pivot from the function bracket (30) and catch the shaft collar, carriage-feed lever (26), spacer (27), and the unshift lever (29) as they fall from the pivot.
 - (17) Remove the two machine screws (31) and lockwashers (32) that hold the punch-bar guide block (39) to the function side of the teletypewriter frame; remove the punch-bar guide block from the frame; be careful to disengage the aperture gate (36) from the platen latching arm (6, fig. 82) and the signal-bell clapper (13, fig. 97), motor-stop actuating lever (18), and the function-selecting arm (1, fig. 101) from the punch-bar guide block.
 - (18) Remove the two machine screws (33, fig. 98) and lockwashers (34) that hold the side plate (35) to the punch-bar guide block (39); remove the side plate, aperture gate (36), signal-bell punch bar (37), and letters and motor-stop punch bars (38) from the punch-bar guide block.
- b. Reassembly.**
- (1) Reassemble the function-selecting mechanism as indicated in figure 98; the sequence for assembling the parts is the reverse of the disassembly sequence.
 - (2) Adjust the function-selecting mechanism (pars. 187, 188, 189, and 260).

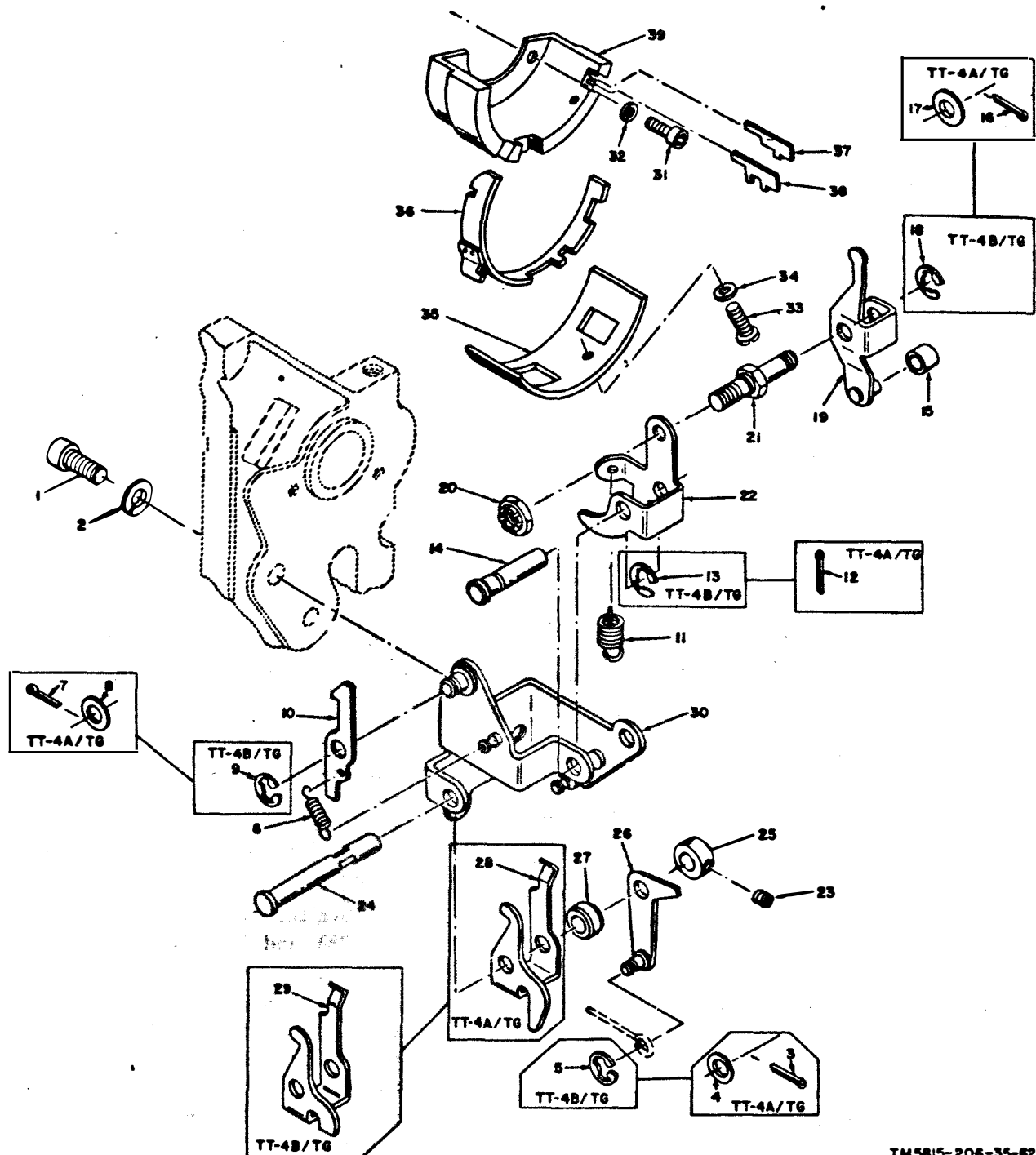

TM5815-206-35-62

Figure 98. Function-selecting mechanism, exploded view.

- | | | |
|---|--|---|
| 1. Machine screw, 10015 | 9. Retainer ring, 10949 | 18. Retainer ring, 10949 |
| 2. Lockwasher, 10405 ^a , 10431 ^b | 10. Platen latch, 50821 | 19. Function-cam follower, 50822A |
| 3. Cotter pin, 10801 | 11. Support-lever spring, 50915 | 20. Self-locking hexagonal nut, 10501 |
| 4. Flat washer, 50319 | 12. Cotter pin, 10801 | 21. Function-cam-follower stud, 50761 ^a , 52553 ^b |
| 5. Retainer ring, 10960 | 13. Retainer ring, 10949 | 22. Support lever, 50760 |
| 6. Platen-latch spring, 50916 ^a , 52501 ^b | 14. Pin, 50828 ^a , 53131 ^b | 23. Setscrew, 10201 |
| 7. Cotter pin, 10801 | 15. Cam-follower roller, 50843 | 24. Pivot, 50829 |
| 8. Flat washer, 50315 | 16. Cotter pin, 10801 | |
| | 17. Flat washer, 50315 | |

- 25. Shaft collar, 50391
- 26. Carriage-feed lever, 51425A*, 53129A*
- 27. Spacer, 51424
- 28. Letters-shift lever, 50756
- 29. Letters-shift lever, 59631

- 30. Function bracket, 50814A*, 52543A*
- 31. Machine screw, 10004
- 32. Lockwasher, 10403*, 10429*
- 33. Machine screw, 10304
- 34. Lockwasher, 10429

- 35. Side plate, 50735
- 36. Aperture gate, 50743A
- 37. Signal-bell punch bar, 50881
- 38. Letters and motor-stop punch bars, 50755
- 39. Punch-bar guide block, 51428

* Used on TT-4A/TG.

* Used on TT-4B/TG.

Figure 98—Continued

95. Disassembly and Reassembly of Line-Feed and Platen-Shift Mechanisms (TT-4A/TG) (fig. 99)

a. Disassembly.

- (1) Remove the bell-crank spring (1) from the line-feed bell crank (17) and from the bell-crank bracket (31).
- (2) Remove the cam-follower spring (2) from the platen-shift-cam follower (21) and from the line-feed-cam follower (5).
- (3) Remove the cotter pin (3) and flat washer (4) that hold the line-feed-cam follower (5) to the pivot stud on the line-feed bell crank (17); remove the line-feed-cam follower by sliding it down to unhook it from the function shaft.
- (4) Remove the cotter pin (6) and flat washer (7) that hold the connecting link (13) to the stud of the line-feed lever (40, fig. 82).
- (5) Remove the cotter pin (8, fig. 99) and flat washer (9) that hold the connecting link (14) to the stud on the line-feed bell crank (17); remove the connecting link.
- (6) Remove the two machine screws (10), lockwashers (11), and flat washers (12) that hold the connecting link (13) to the connecting link (14); separate the connecting links.
- (7) Remove the cotter pin (15) and flat washer (16) that hold the line-feed bell crank (17) to the bell-crank bracket; remove the line-feed bell crank.
- (8) Remove the platen-shift bell-crank spring (18) from the platen-shift bell crank (27) and from the bracket link.
- (9) Remove the cotter pin (19) and flat

washer (20) that hold the platen-shift-cam follower (21) to the pivot stud on the platen-shift bell crank (27); remove the platen-shift-cam follower by sliding it down to unhook it from the function shaft.

- (10) Remove the cotter pin (22) and flat washer (23) that hold the platen-shift link (26) to the stud on the platen-shift arm.
- (11) Remove the cotter pin (24) and flat washer (25) that hold the platen-shift link (26) to the stud on the platen-shift bell crank (27); remove the platen-shift link and remove the platen-shift bell crank from the bell-crank bracket.
- (12) Remove the carriage-return bell-crank spring (28) from the bell-crank bracket (31) and from the carriage-return sensing lever.
- (13) Remove the two machine screws (29) and lockwashers (30) that hold the bell-crank bracket (31) to the frame; remove the bell-crank bracket.

b. Reassembly.

- (1) Reassemble the line-feed and platen-shift mechanisms as indicated in figure 99; the sequence for assembling the parts is the reverse of the disassembly sequence.
- (2) Adjust the line-feed and platen-shift mechanisms (pars. 244 through 246).

96. Disassembly and Reassembly of Line-Feed and Platen-Shift Mechanisms (TT-4B/TG) (fig. 100)

a. Disassembly.

- (1) Remove the bell-crank spring (1) from the adjusting arm (18) and from the bell-crank bracket (33).
- (2) Remove the cam-follower spring (2) from the line-feed-cam follower (4)

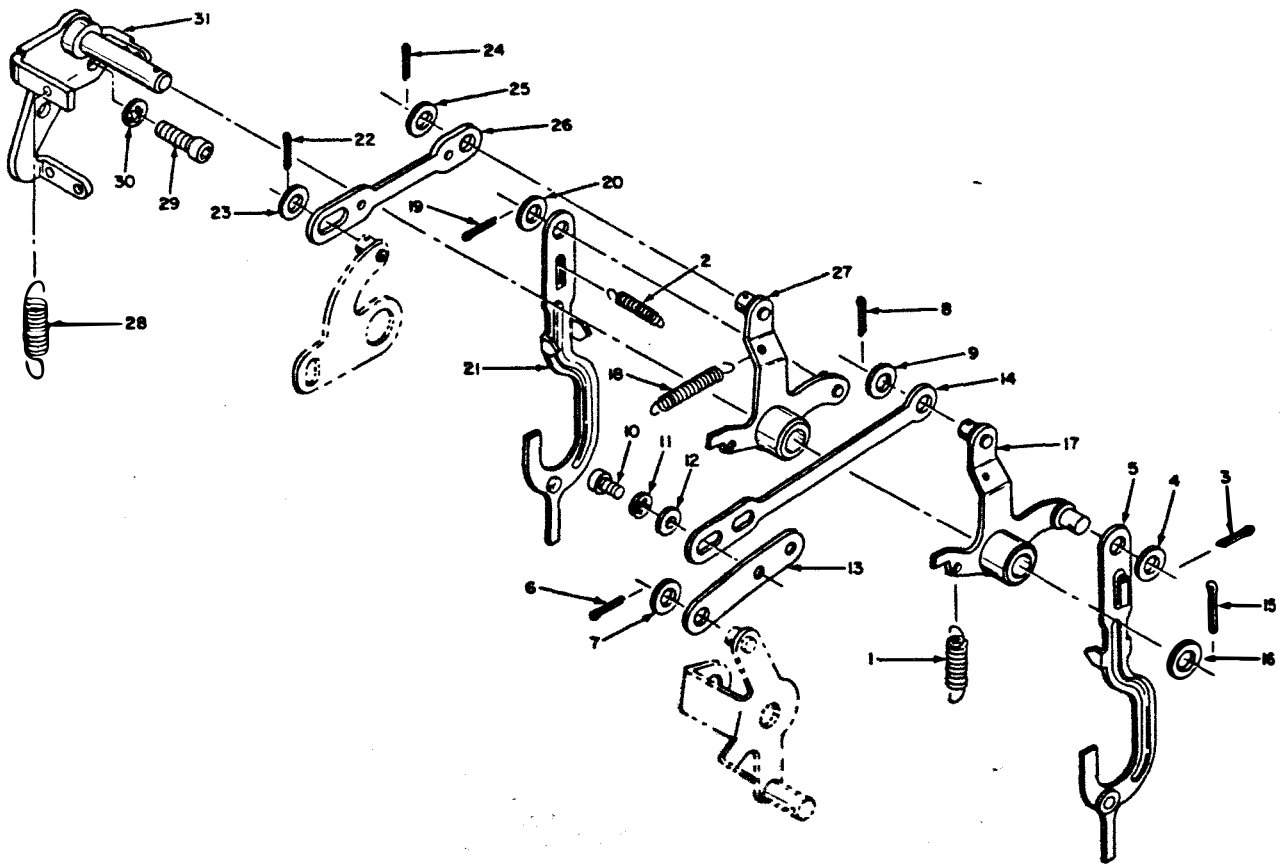

TM5815-206-35-63

- | | | |
|-----------------------------------|---|--|
| 1. Bell-crank spring, 51755 | 18. Connecting link, 51771 | 22. Cotter pin, 10802 |
| 2. Cam-follower spring, 50901 | 14. Connecting link, 50474 | 23. Flat washer, 50315 |
| 3. Cotter pin, 10801 | 15. Cotter pin, 10802 | 24. Cotter pin, 10802 |
| 4. Flat washer, 50315 | 16. Flat washer, 50494 | 25. Flat washer, 50315 |
| 5. Line-feed-cam follower, 51714A | 17. Line-feed bell crank, 51753A | 26. Platen-shift link, 51693 |
| 6. Cotter pin, 10801 | 18. Platen-shift bell-crank spring, 51645 | 27. Platen-shift bell crank, 53135A |
| 7. Flat washer, 50315 | 19. Cotter pin, 10801 | 28. Carriage-return bell-crank spring, 50906 |
| 8. Cotter pin, 10801 | 20. Flat washer, 50315 | 29. Machine screw, 10008 |
| 9. Flat washer, 50315 | 21. Platen-shift-cam follower, 51712A | 30. Lockwasher, 10404 |
| 10. Machine screw, 10002 | | 31. Bell-crank bracket, 50478A |
| 11. Lockwasher, 10403 | | |
| 12. Flat washer, 10458 | | |

Figure 99. Line-feed and platen-shift mechanisms, (TT-4/TG), exploded view.

- and from the platen-shift-cam follower (22).
- (3) Remove the retainer ring (3) that holds the line-feed-cam follower (4) to the pivot stud on the line-feed bell crank (19); remove the line-feed-cam follower by sliding it down to unhook it from the function shaft.
- (4) Remove the retainer ring (5) that holds the connecting link (10) to the stud of the line-feed lever.
- (5) Remove the retainer ring (6) that holds the connecting link (11) to

- the stud on the line-feed bell crank (19); remove the connecting links.
- (6) Remove the two machine screws (7), lockwashers (8), and flat washers (9) that hold the connecting link (10) to connecting link (11); separate the connecting links.
- (7) Remove the machine screw (12), lockwasher (13), and flat washer (14) that hold the line-feed bell crank (19) to the bell-crank bracket (33); remove the line-feed bell crank.
- (8) Remove the self-locking hexagonal

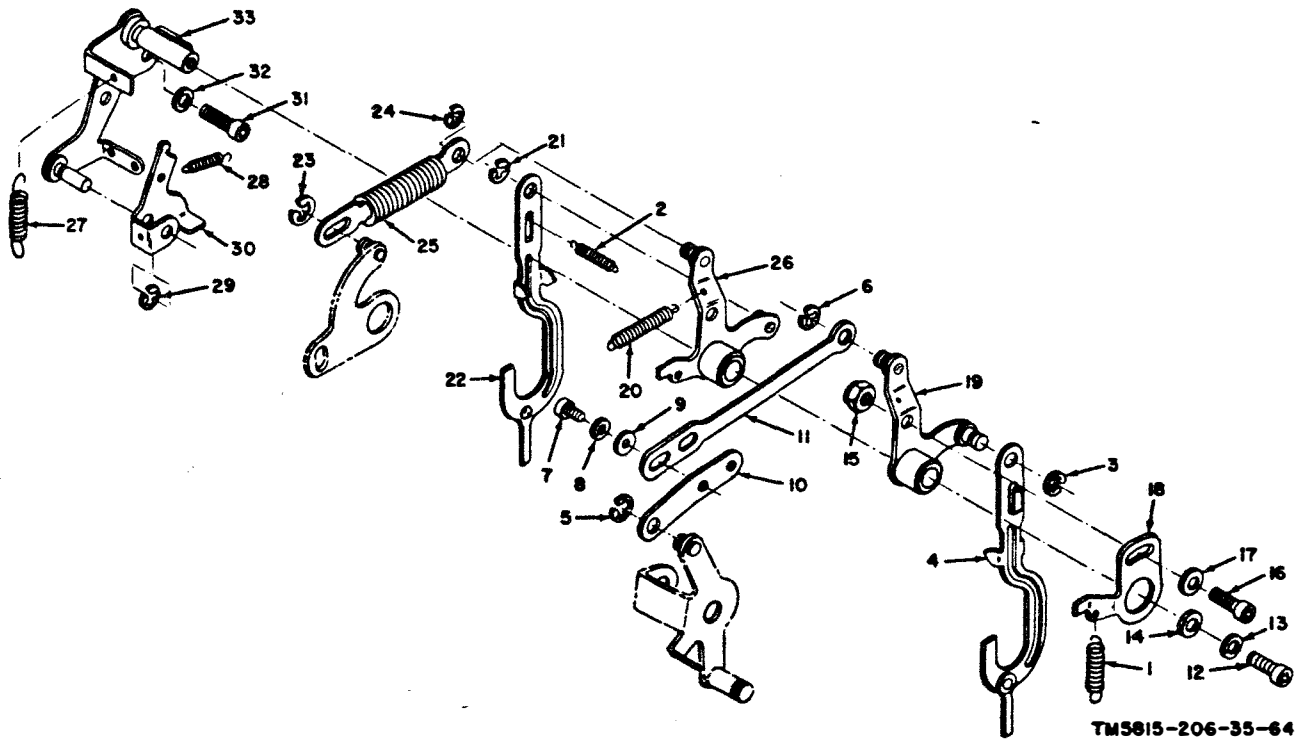

- | | | |
|-----------------------------------|--|--|
| 1. Bell-crank spring, 51755 | 14. Flat washer, 10450 | 23. Retainer ring, 10949 |
| 2. Cam-follower spring, 50901 | 15. Self-locking hexagonal nut, 10500 | 24. Retainer ring, 10949 |
| 3. Retainer ring, 10949 | 16. Machine screw, 10003 | 25. Platen-shift link, 56676A |
| 4. Line-feed-cam follower, 51714A | 17. Flat washer, 10450 | 26. Platen-shift bell crank, 53135A |
| 5. Retainer ring, 10949 | 18. Adjusting arm, 53462 | 27. Carriage-return bell-crank spring, 50906 |
| 6. Retainer ring, 10949 | 19. Line-feed bell crank, 53463A, (includes items 15 through 18) | 28. Platen lower-case latch spring, 50920 |
| 7. Machine screw, 10001 | 20. Platen-shift bell-crank spring, 51645 | 29. Retainer ring, 10960 |
| 8. Lockwasher, 10429 | 21. Retainer ring, 10949 | 30. Platen lower-case latch, 52748 |
| 9. Flat washer, 10458 | 22. Platen-shift-cam follower, 51712A | 31. Machine screw, 10025 |
| 10. Connecting link, 51771 | | 32. Lockwasher, 10430 |
| 11. Connecting link, 50474 | | 33. Bell-crank bracket, 52303A |
| 12. Machine screw, 10003 | | |
| 13. Lockwasher, 10429 | | |

Figure 100. Line-feed and platen-shift mechanisms (TT-4B/TG), exploded view.

nut (15), machine screw (16) and flat washer (17) that hold the adjusting arm (18) to the line-feed bell crank (19); remove the adjusting arm.

- (9) Remove the platen-shift bell-crank spring (20) from the platen-shift bell crank (26) and from the bracket link.
- (10) Remove the retainer ring (21) that holds the platen-shift-cam follower (22) to the pivot stud of the platen-shift bell crank (26); remove the platen-shift-cam follower by sliding it down to remove it from the function shaft.
- (11) Remove the retainer ring (23) that holds the platen-shift link (25) to the

stud on the platen-shift arm (19, fig. 82).

- (12) Remove the retainer ring (24, fig. 100) that holds the platen-shift link (25) to the stud on the platen-shift bell crank (26); remove the platen-shift link and the platen-shift bell crank from the bell-crank bracket (33).
- (13) Remove the carriage-return bell-crank spring (27) from the bell-crank bracket (33) and from the carriage-return sensing lever (15, fig. 108).
- (14) Remove the platen lower-case latch spring (28, fig. 100) from the platen lower-case latch (30) and from the bell-crank bracket (33).
- (15) Remove the retainer ring (29) that

holds the platen lower-case latch (30) to the pivot post on the bell-crank bracket (33); remove the platen lower-case latch.

- (16) Remove the two machine screws (31) and lockwashers (32) that hold the bell-crank bracket (33) to the teletypewriter frame; remove the bell-crank bracket.

b. Reassembly.

- (1) Reassemble the line-feed and platen-shift mechanism as indicated in figure 100; the sequence for assembling the parts is the reverse of the disassembly sequence.
- (2) Adjust the line-feed and platen-shift mechanisms (pars. 244 and 245).

97. Disassembly and Reassembly of Square-Shaft Assembly
(fig. 101)

a. Disassembly.

- (1) Loosen the four setscrews (10) that hold the square-shaft driven gear (11) to the square shaft (13).
- (2) Remove the support lever (22, fig. 98) and the function-cam follower (19) as described in paragraph 94a.
- (3) Remove the function-selecting arm (1, fig. 101) and the function-selecting-arm spring (2) from the square shaft (13).
- (4) Remove the machine screw (3) that holds the function-selecting-arm claw (4) on the square shaft (13); remove the function-selecting arm claw.
- (5) On the TT-4A/TG, move the square shaft (13) axially toward the function side to dislodge the two ball bearings (8) from their seats in the frame; remove the two ball bearings.
- (6) On the TT-4B/TG, remove the spring retainer (5), square-shaft-bearing spring (6), and spring retainer (7) from the square shaft (13).
- (7) On the TT-4B/TG, move the square shaft (13) axially toward the function side to dislodge the ball bearing (8) from its seat in the frame; remove the ball bearing and the spacing collar (9).

- (8) Pull the square shaft (13) from the opening in the frame; remove the square-shaft driven gear (11) and the square-shaft sliding gear (12) from the square shaft as it is removed.

b. Reassembly.

- (1) Reassemble the square-shaft assembly as indicated in figure 101; the sequence for assembling the parts is the reverse of the disassembly sequence.
- (2) Replace the support lever and the function-cam follower as described in paragraph 94b.
- (3) Tighten the four setscrews (10) that hold the square-shaft driven gear (11) to the square shaft (13).
- (4) Adjust the square-shaft assembly (pars. 222, 153, 154, and 224).

98. Removal and Replacement of Function-Shaft Assembly
(fig. 102)

a. Removal.

- (1) Remove the teletypewriter from the mounting base (par. 59a).
- (2) Remove the signal-bell and motor-stop actuating levers from the function side of the frame (par. 93a).
- (3) Remove the transfer-lever shaft assembly (par. 91a).
- (4) Remove the cam-follower spring (par. 95a(2) or 96a(2)).
- (5) Remove the line-feed-cam follower (par. 95a(3) or 96a(3)).
- (6) Remove the setscrew (26, fig. 126) that holds the spacing collar (27) to the cam-follower stop stud (28); remove the collar and the stop stud.
- (7) Remove the platen-shift-cam follower (par. 95a or 96a).
- (8) Remove the two machine screws (1, fig. 102) and lockwashers (2) that hold the bearing cap to the frame; remove the bearing cap.
- (9) Remove the machine screw (3), lockwasher (4), machine screw (5), and lockwasher (6) that hold the center bearing cap to the frame. slide the center bearing cap toward the selector side of the frame to clear the print-bail shaft before removing the bearing cap.

3) from the remove the (1) and the r (2) from removed.

shaft assembly 101; the se e parts is the ly sequence. ver and the described in

ws (10) that driven gear (13).

ft assembly (224).

ter from the). and motor-stop the function 3a) shaft as- vel spring (par. cam follower

26, fig. 126) collar (27) to stud (28); re- top stud. cam follower

screws (1, fig. 2) that hold frame; remove

ew (3), lock- rew (5), and ld the center ne. slide the ard the selec- to clear the removing the

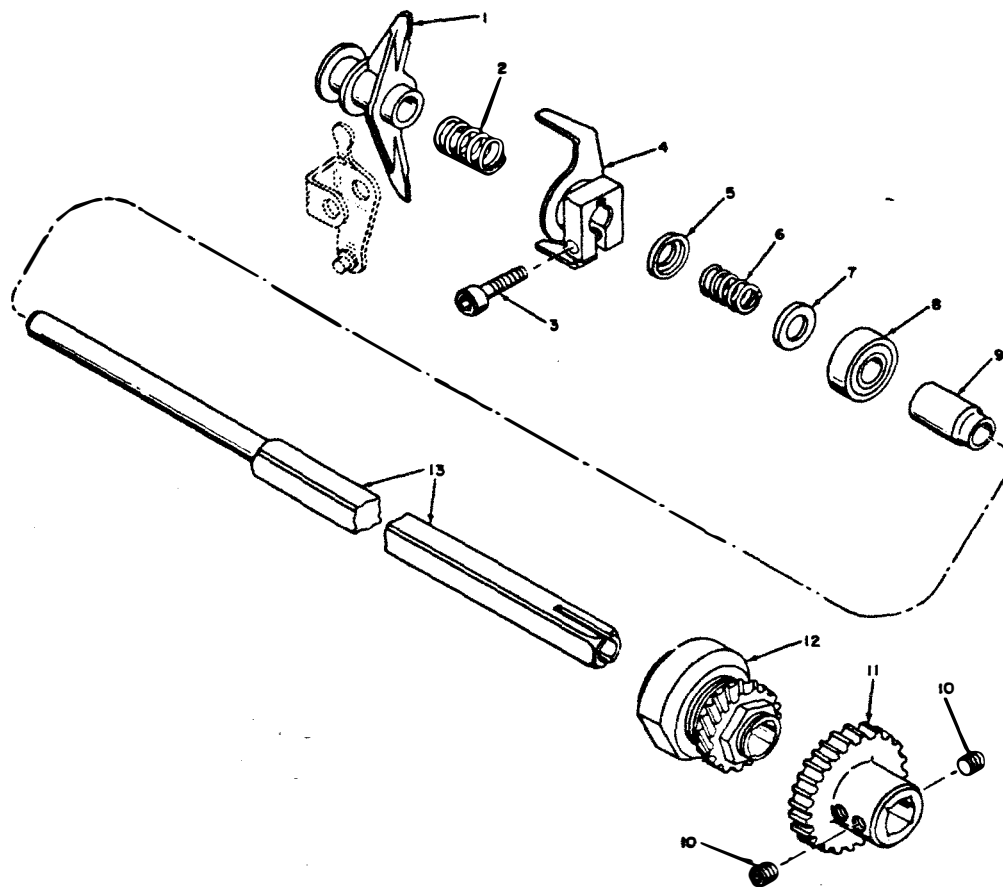

TM5815-206-35-190

1. Function-selecting arm, 50936
2. Function-selecting-arm spring, 50917
3. Machine screw, 10009
4. Function-selecting-arm claw, 50841A (includes item 3)

5. Spring retainer, 56277*
6. Square-shaft-bearing spring, 56279*
7. Spring retainer, 56277*
8. Ball bearing, 10753
9. Spacing collar, 56278*

10. Setscrew, 190209
11. Square-shaft driven gear, 50383
12. Square-shaft sliding gear, 50565A
13. Square shaft, 50456*, 57711*

* Used on TT-4A/TG.

* Used on TT-4B/TG.

Figure 101. Square-shaft assembly, exploded view.

- (10) Remove the two machine screws (7) and lockwashers (8) that hold the bearing cap to the frame; remove the bearing cap.
 - (11) Loosen the two setscrews (41) that hold the print cam (42) to the function shaft (46). Slide the print cam on the shaft to disengage it from the bushing on the print-cam follower.
 - (12) Remove the assembled function shaft (46) by pulling it upward and outward from the three bearing supports in the frame.
- b. Replacement.**
- (1) Replace the function-shaft assembly as indicated in figure 102; the sequence for replacing the parts is

- the reverse of the removal sequence.
- (2) Replace the platen-shift-cam follower (par. 95b or 96b).
- (3) Replace the cam-follower stop stud (28, fig. 126) on the frame.
- (4) Replace the line-feed-cam follower (par. 95b or 96b).
- (5) Replace the cam-follower spring (par. 95b or 96b).
- (6) Replace the transfer-lever shaft assembly (par. 91b).
- (7) Replace the signal bell and motor-stop actuating lever on the function side of the frame (par. 93b).
- (8) Adjust the function shaft (pars. 161, 152, 155, 225, and 168 through 170).

TM5015-208-35-63

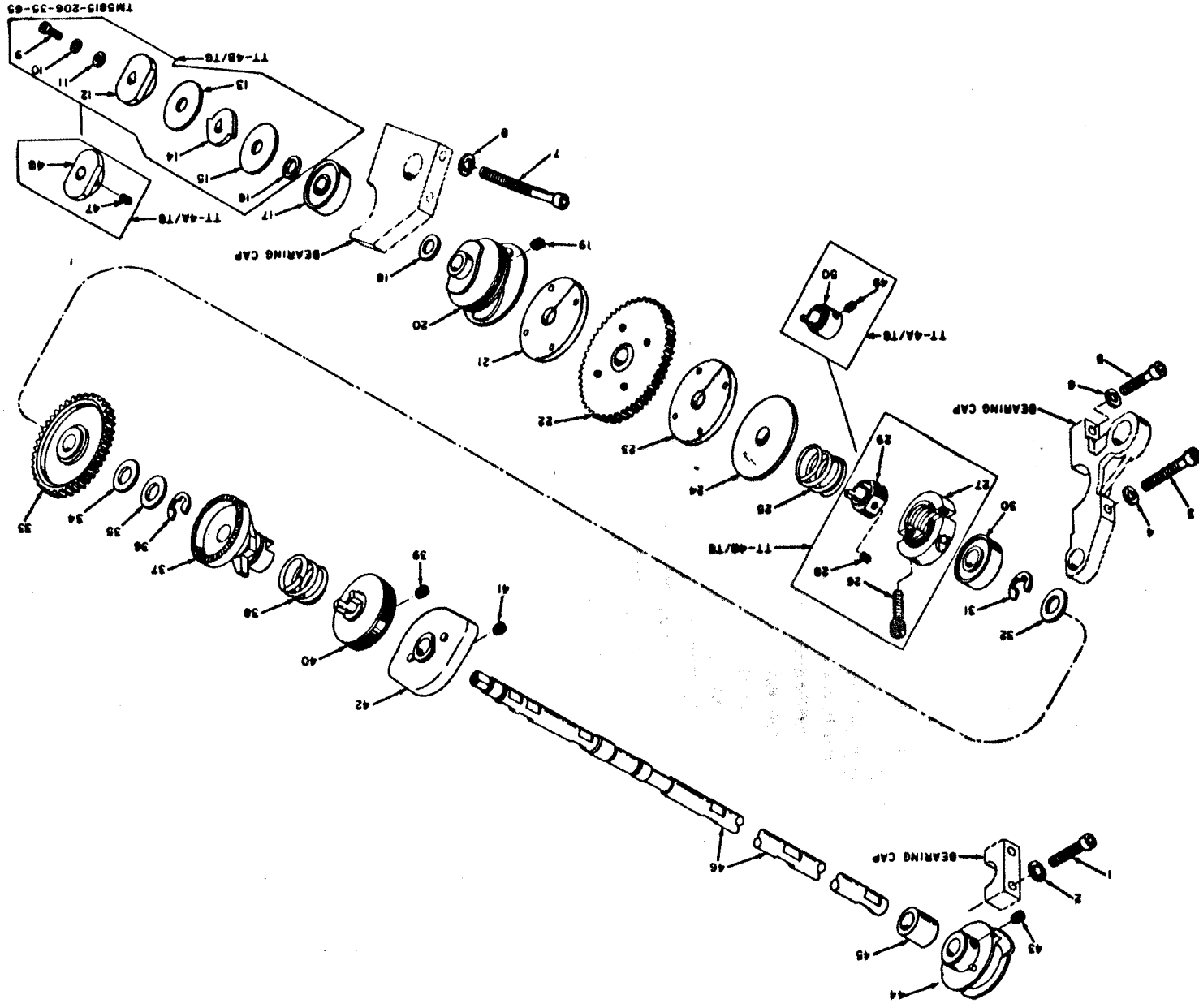
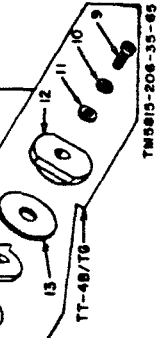

Figure 108. Reaction shaft assembly exploded view.

- 
- | | | |
|---|--|---|
| 1. Machine screw, 10011 | 20. Function cam assembly, 56618A | 34. Spacer (.004-in.), 51847 |
| 2. Lockwasher, 10404 ^a , 10430 ^b | 21. Friction plate, 56764 | Spacer (.006-in.), 51848 |
| 3. Machine screw, 10013 ^a , 10012 ^b | 22. Square-shaft driving gear, 50496A ^a , 56274A ^b | 35. Flat washer, 50515 |
| 4. Lockwasher, 10430 | 23. Felt friction plate, 56764 | 36. Retainer ring, 10959 |
| 5. Machine screw, 10011 | 24. Friction-clutch disk, 50491 ^a , 54929 ^b | 37. Function-clutch drum, 50536 ^a , 57893 ^b |
| 6. Lockwasher, 10430 | 25. Friction-clutch spring, 50847 ^a , 54933 ^b | 38. Clutch spring, 50848 |
| 7. Machine screw, 10014 | 26. Machine screw, 10043 | 39. Setscrew, 10209 |
| 8. Lockwasher, 10404 ^a , 10430 ^b | 27. Friction-adjusting collar, 56832A (includes item 26) | 40. Flexible-coupling disk, 51167A |
| 9. Machine screw, 10003 | 28. Setscrew, 10208 | 41. Set screw, 10209 |
| 10. Lockwasher, 10429 | 29. Drive collar, 54927 | 42. Print cam, 50753A |
| 11. Flat washer, 10450 | 30. Ball bearing, 10757 | 43. Setscrew, 10209 |
| 12. Transfer-lever restoring cam, 53878 | 31. Retainer ring, 10959 | 44. Function cam, 50752A |
| 13. Flat washer, 53885 | 32. Flat washer, 50515 | 45. Sleeve bearing, 50852 |
| 14. Locking-bail cam, 53881 | 33. Function-shaft driven gear, 50512A | 46. Function shaft, 50655 ^a , 55522 ^b |
| 15. Flat washer, 53885 | | 47. Setscrew, 10209 |
| 16. Flat washer, 50494 | | 48. Transfer-lever restoring cam, 50536 |
| 17. Ball bearing, 10756 | | 49. Setscrew, 10209 |
| 18. Laminated washer, 50552 | | 50. Friction-adjusting collar, 50492 |
| 19. Setscrew, 10208 | | |

^a Used on TT-4A/TG.

^b Use TT-4B/TG.

Figure 102—Continued

(9) Replace the teletypewriter on the mounting base (par. 59b).

99. Disassembly and Reassembly of Function-Shaft Assembly (fig. 102)

a. Disassembly.

- (1) Remove the function-shaft assembly from the teletypewriter (par. 98a).
- (2) On the TT-4A/TG, remove the two setscrews (47) that hold the transfer-lever restoring cam (48) to the function shaft (46); remove the cam, ball bearing (17), and laminated washer (18).
- (3) On the TT-4B/TG, remove the machine screw (9), lockwasher (10), and flat washer (11) that hold the transfer-lever restoring cam (12) to the function shaft (46); remove the transfer-lever restoring cam, flat washer (13), locking-bail cam (14), flat washers (15), flat washer (16), ball bearing (17), and laminated washer (18).
- (4) Remove the two setscrews (19) that hold the function-cam assembly (20) to the function shaft (46); remove the cam assembly, friction plate (21), square-shaft driving gear (22), felt friction plate (23), friction-clutch disk (24), and friction-clutch spring (25).
- (5) On the TT-4A/TG, remove the two setscrews (49) that hold the friction-adjusting collar (50) to the function

shaft (46); remove the friction-adjusting collar.

- (6) On the TT-4B/TG, loosen the two machine screws (26) that hold the friction-adjusting collar (27) to the drive collar (29); unscrew and remove the friction-adjusting collar from the drive collar.
- (7) On the TT-4B/TG, remove the two setscrews (28) that hold the drive collar (29) to the function shaft (46); remove the drive collar.
- (8) Remove the ball bearing (30) from the function shaft (46).
- (9) Remove the retainer ring (31) that holds the function-shaft driven gear (33) on the function shaft (46); remove the flat washer (32), function-shaft driven gear (33), spacer (34), and flat washer (35).
- (10) Remove the retainer ring (36) that holds the function-clutch drum (37) on the function shaft (46); remove the function-clutch drum and the clutch spring (38).
- (11) Remove the two set screws (39) that hold the flexible-coupling disk (40) to the function shaft (46); remove the flexible-coupling disk.
- (12) Remove the two setscrews (41) that hold the print cam (42) to the function shaft (46); remove the print cam.
- (13) Remove the two setscrews (43) that hold the function cam (44) to the

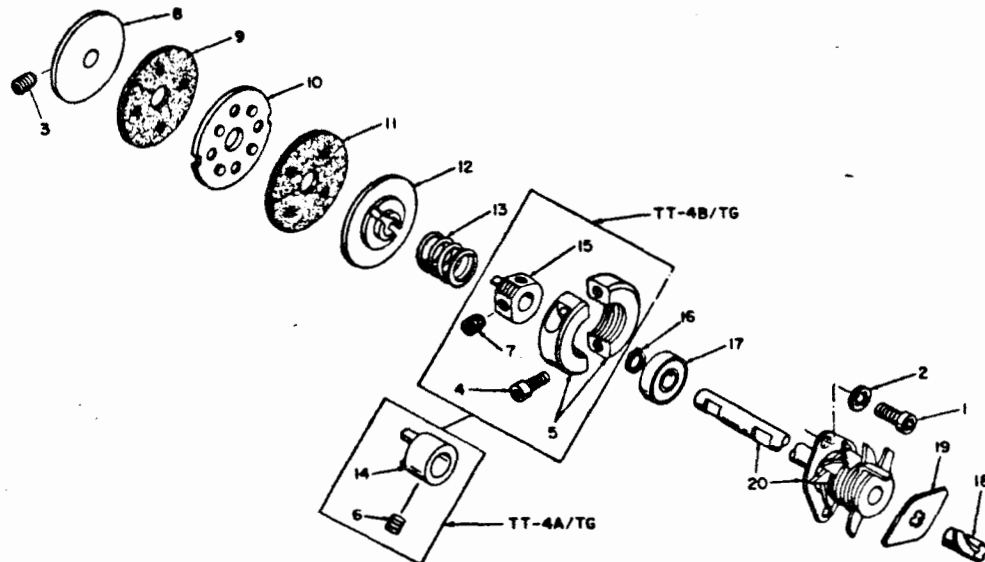

TM 5815-206-35-66

- | | | |
|--|---|---|
| 1. Machine screw, 10003 | 8. Clutch disk, 50200 | 15. Drive collar, 54928 |
| 2. Lockwasher, 10403 | 9. Felt friction plate, 56765 | 16. Retainer ring, 10462 |
| 3. Setscrew, 10209 | 10. Clutch disk, 51117 | 17. Ball bearing, 10753 |
| 4. Machine screw, 10005 | 11. Felt friction plate, 56765 | 18. Grooved pin, 50133 |
| 5. Friction-adjusting collar, 56832
(includes item 4) | 12. Clutch disk, 50198*, 54931* | 19. Stop plate, 50134 |
| 6. Setscrew, 10209 | 13. Friction-clutch spring, 50914*,
54932* | 20. Selector camshaft, 51398A
(includes items 16 through 19) |
| 7. Setscrew, 10208 | 14. Friction-adjusting collar, 50199 | |

* Used on TT-4A/TG.

* Used on TT-4B/TG.

Figure 103. Selector camshaft assembly, exploded view.

function shaft (46); remove the function cam.

- (14) Remove the sleeve bearing (45) from the function shaft (46).

b. Reassembly.

- (1) Reassemble the function-shaft assembly as indicated in figure 102); the sequence for assembling the parts is the reverse of the disassembly sequence.
- (2) Replace the function-shaft assembly on the teletypewriter frame (par. 98b).

100. Disassembly and Reassembly of Selector Camshaft Assembly (fig. 103)

a. Disassembly.

- (1) Remove one paper-shaft bracket and the paper chute (par. 58a).
- (2) Remove the self-locking hexagonal nut (8, fig. 92) and flat washer (9) that hold the orientation lever (10 or 11) to the orientation-lever stud (13); remove the orientation lever.

- (3) Remove the two machine screws (1, fig. 103) and lockwashers (2) that hold the ball bearing (17) to the selector side of the frame.
- (4) Remove the two setscrews (3) that hold the clutch disk (8) to the selector camshaft (20).
- (5) On the TT-4B/TG, remove the two machine screws (4) that hold the friction-adjusting collar (5) to the driving collar (15); remove the friction-adjusting collar.
- (6) On the TT-4A/TG, remove the two setscrews (6) that hold the friction-adjusting collar (14) to the selector camshaft (20). Remove the selector camshaft and ball bearing (17) from the frame; catch the clutch disk (8), felt friction plate (9), clutch disk (10), felt friction plate (11), clutch disk (12), friction-clutch spring (13), and friction-adjusting collar (14) as they fall from the selector camshaft.
- (7) On the TT-4B/TG, remove the two setscrews (7) that hold the driving col-

lar (15) to the selector camshaft (20). Remove the selector camshaft and ball bearing (17) from the frame; catch the clutch disk (8), felt friction plate (9), clutch disk (10), felt friction plate (11), clutch disk (12), friction-clutch spring (13), and drive collar (15) as they fall from the selector camshaft.

- (8) Remove the retainer ring (16) that holds the ball bearing (17) to the selector camshaft (20); remove the ball bearing.
- (9) Bend the tab on the end of the selector camshaft (20) to release the stop plate (19); remove the grooved pin (18) and stop plate from the camshaft. Remove the grooved pin from the stop plate.

b. Reassembly.

- (1) Reassemble the selector camshaft assembly as indicated in figure 103; the sequence for assembling the parts is the reverse of the disassembly sequence.
- (2) Adjust the selector camshaft assembly (pars. 174 and 175).
- (3) Replace the paper-shaft bracket and paper chute (par. 58b).

101. Disassembly and Reassembly of Main Shaft Assembly (TT-4A/TG)

(fig. 104)

a. Disassembly.

- (1) Remove the teletypewriter from the mounting base (par. 59a).
- (2) Remove one paper-shaft bracket and the paper chute (par. 58a).
- (3) Remove the gear cover, worm gear bracket, and gasket from the frame (par. 60a).
- (4) Remove the machine screw (1) and lockwasher (2) that hold the main-shaft gear (3) to the main shaft (31). Loosen the four motor mounting machine screws (1, fig. 81) and remove the main-shaft gear.
- (5) Remove the machine screw (4), lockwasher (5), and flat washer (6)

that hold the ball bearing (29) in the frame.

- (6) Remove the self-locking hexagonal nut (7) and lock washer (8) that hold the grounding wiper (9) to the machine screw (11); remove the grounding wiper, lockwasher (10), machine screw (11), lockwasher (12), and flat washer (13).
- (7) Block-up the main shaft (31) with pieces of wood placed between the shaft and the frame. Remove the four taper pins (14, 15, 16, and 17) that hold the function-shaft driving gear (20), carriage-feed worm (21), carriage-return-shaft drive gear (22), and transmitter-shaft drive gear (23) to the main shaft.
- (8) Remove the two setscrews (18) that hold the selector-friction-clutch fork (19) to the main shaft (31).
- (9) Remove the main shaft (31) by pulling it out of the frame from the motor end; remove the selector-friction-clutch fork (19), function-shaft driving gear (20), carriage-feed worm (21), carriage-return shaft drive gear (22), and transmitter-shaft drive gear (23) from the main shaft as it is removed.
- (10) Remove the machine screw (24), lockwasher (25), and flat washer (26) that hold the ball bearing (27) in the frame; remove the ball bearing.
- (11) Remove the main-shaft-gear pin (28), ball bearing (29), and flat washer (30) from the main shaft (31).

b. Reassembly.

- (1) Reassemble the main shaft assembly as indicated in figure 104; the sequence for assembling the parts is the reverse of the disassembly sequence.
- (2) Replace the gear cover, worm gear bracket, and gasket on the teletypewriter frame (par. 60b).
- (3) Replace the paper-shaft bracket and paper chute (par. 58b).
- (4) Replace the teletypewriter on the mounting base (par. 59b).

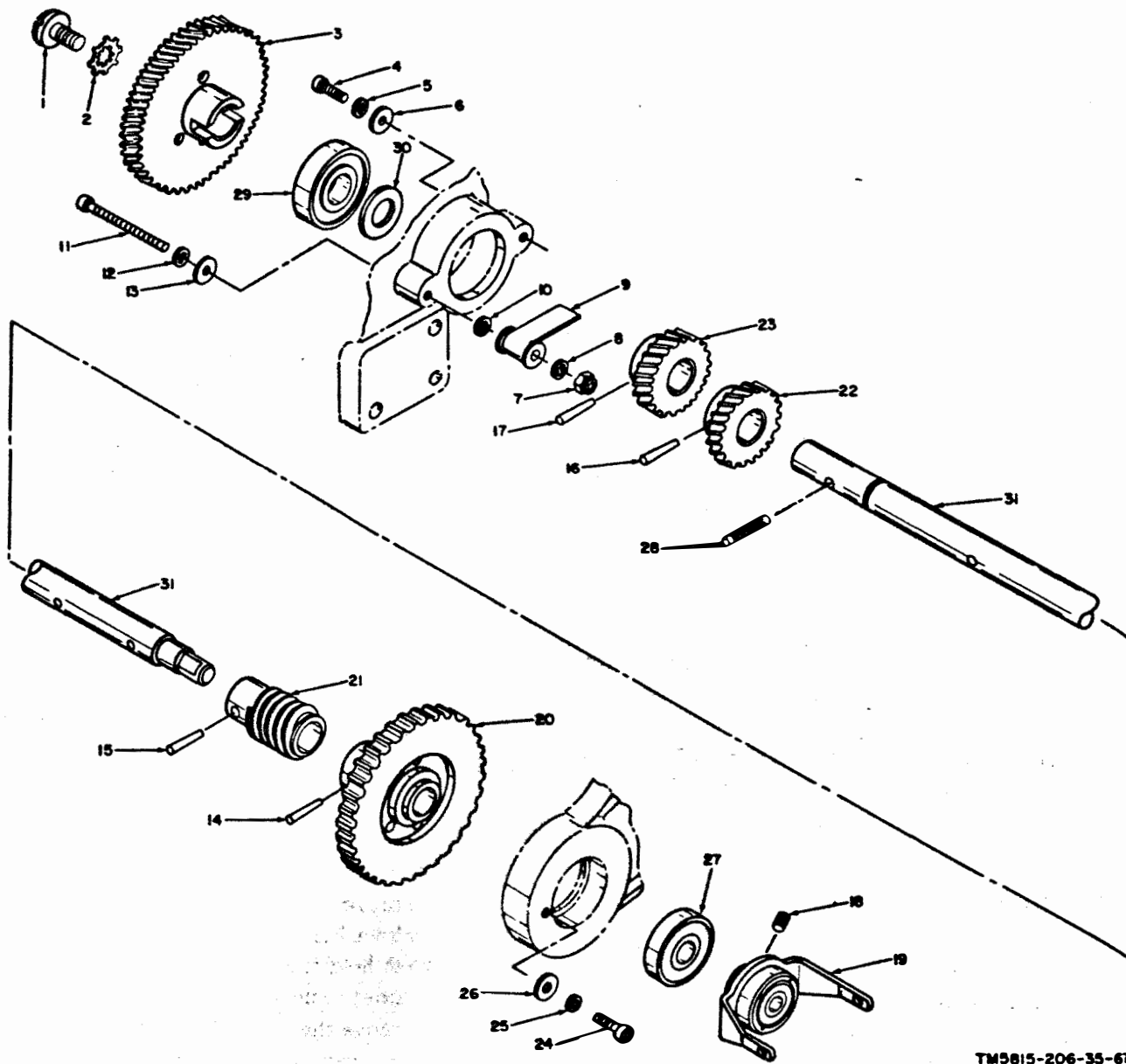

TM5815-206-35-67

- | | | |
|--------------------------------------|---|---|
| 1. Machine screw, 50207 | 12. Lockwasher, 10403 | 22. Carriage-return-shaft drive gear, 50357 |
| 2. Lockwasher, 10406 | 13. Flat washer, 10450 | 23. Transmitter-shaft drive gear, 50285 |
| 3. Mainshaft gear, 50352A | 14. Taper pin, 10852 | 24. Machine screw, 10004 |
| 4. Machine screw, 10003 | 15. Taper pin, 10850 | 25. Lockwasher, 10429 |
| 5. Lockwasher, 10403 | 16. Taper pin, 10852 | 26. Flat washer, 10450 |
| 6. Flat washer, 10450 | 17. Taper pin, 10852 | 27. Ball bearing, 10757 |
| 7. Self-locking hexagonal nut, 10500 | 18. Setscrew, 10209 | 28. Main-shaft-gear pin, 50359 |
| 8. Lockwasher, 10403 | 19. Selector-friction-clutch fork, 50484A | 29. Ball bearing, 10758 |
| 9. Grounding wiper, 51160A | 20. Function-shaft driving gear, 50354A | 30. Flat washer, 50746 |
| 10. Lockwasher, 10403 | 21. Carriage-feed worm, 50268 | 31. Main shaft, 50653 |
| 11. Machine screw, 10023 | | |

Figure 104. Main shaft assembly (TT-4A)/TG, exploded view.

102. Removal and Replacement of Main Shaft Assembly (TT-4B/TG) (fig. 105)

a. Removal.

- (1) Remove the teletypewriter from the mounting base (par. 59a).
- (2) Remove the paper-shaft bracket and paper chute (par. 58a).

- (3) Remove the gear cover, worm gear bracket, and gasket from the frame (par. 60a).
- (4) Remove the machine screw (1) and lockwasher (2). Loosen the four motor mounting machine screws (4, fig. 81) and remove the main-shaft gear (3).
- (5) Remove the drive keys (4) from the main-shaft gear (3).
- (6) Remove the two machine screws (5), lockwashers (6), and flat washers (7) that hold the ball bearing (8); remove the ball bearing.
- (7) Remove the two machine screws (9) and lockwashers (10) that hold the bearing cap to the frame; remove the bearing cap.
- (8) Remove the orientation lever (11, fig. 92) from the rangefinder mechanism.
- (9) Remove the two machine screws (1, fig. 103) and lockwashers (2). Pull the selector camshaft (20) out of the frame far enough to allow the selector-friction-clutch fork (12, fig. 105) to clear the felt friction plate (9, fig. 103) on the selector camshaft.
- (10) With the function shaft in the stop position, remove the main shaft (22, fig. 105).

b. Replacement.

- (1) Insert the left end of the main shaft (22, fig. 105) in the hole in the function side of the frame.
- (2) Position the ball bearing (13) in the bearing seat in the selector side of the frame. Position the bearing cap on the bearing and on the frame. Secure the cap with the two machine screws (9) and lockwashers (10).
- (3) Install the ball bearing (8) on the function side of the main shaft (22) and in the bearing seat in the frame. Secure it with two machine screws (5), lockwashers (6), and flat washers (7).
- (4) Position the five drive keys (4) on the main-shaft gear (3).
- (5) Install the main-shaft gear (3) on the main shaft (22) and secure it with a machine screw (1) and lockwasher (2).

Note. Be sure to install the correct gear for the operating speed desired.

- (6) Install the orientation lever (11, fig. 92) on the rangefinder mechanism.
- (7) Move the selector camshaft (20, fig. 103) in so that the felt friction plate (9) of the friction clutch engages the selector-friction-clutch fork (12, fig. 105) on the main shaft (22).
- (8) Install the two machine screws (1, fig. 103) and lockwashers (2) that hold the selector camshaft (20) to the selector side of the frame.
- (9) Replace the gasket, gear cover, and worm gear bracket on the frame (par. 60b).
- (10) Replace the paper-shaft bracket and paper chute (par. 58b).
- (11) Replace the teletypewriter on the mounting base (par. 59b).

103. Disassembly and Reassembly of Main Shaft Assembly (TT-4B/TG)

(fig. 105)

a. Disassembly.

- (1) Remove the main shaft assembly (par. 102a).
- (2) Remove the two setscrews (11) that hold the selector-friction-clutch fork (12) to the main shaft (22); remove the clutch fork.
- (3) Remove the ball bearing (13) from the main shaft.
- (4) Drive out the taper pin (14) that holds the function-shaft driving gear (15) to the main shaft (22); remove the function-shaft driving gear.
- (5) Drive out the taper pin (16) that holds the carriage-feed worm (17) to the main shaft (22); remove the carriage-feed worm.
- (6) Drive out the taper pin (18) that holds the carriage-return-shaft drive gear (19) to the main shaft (22); remove the carriage-return-shaft drive gear.
- (7) Drive out the taper pin (20) that holds the transmitter-shaft drive gear (21) to the main shaft (22); remove the transmitter-shaft drive gear.

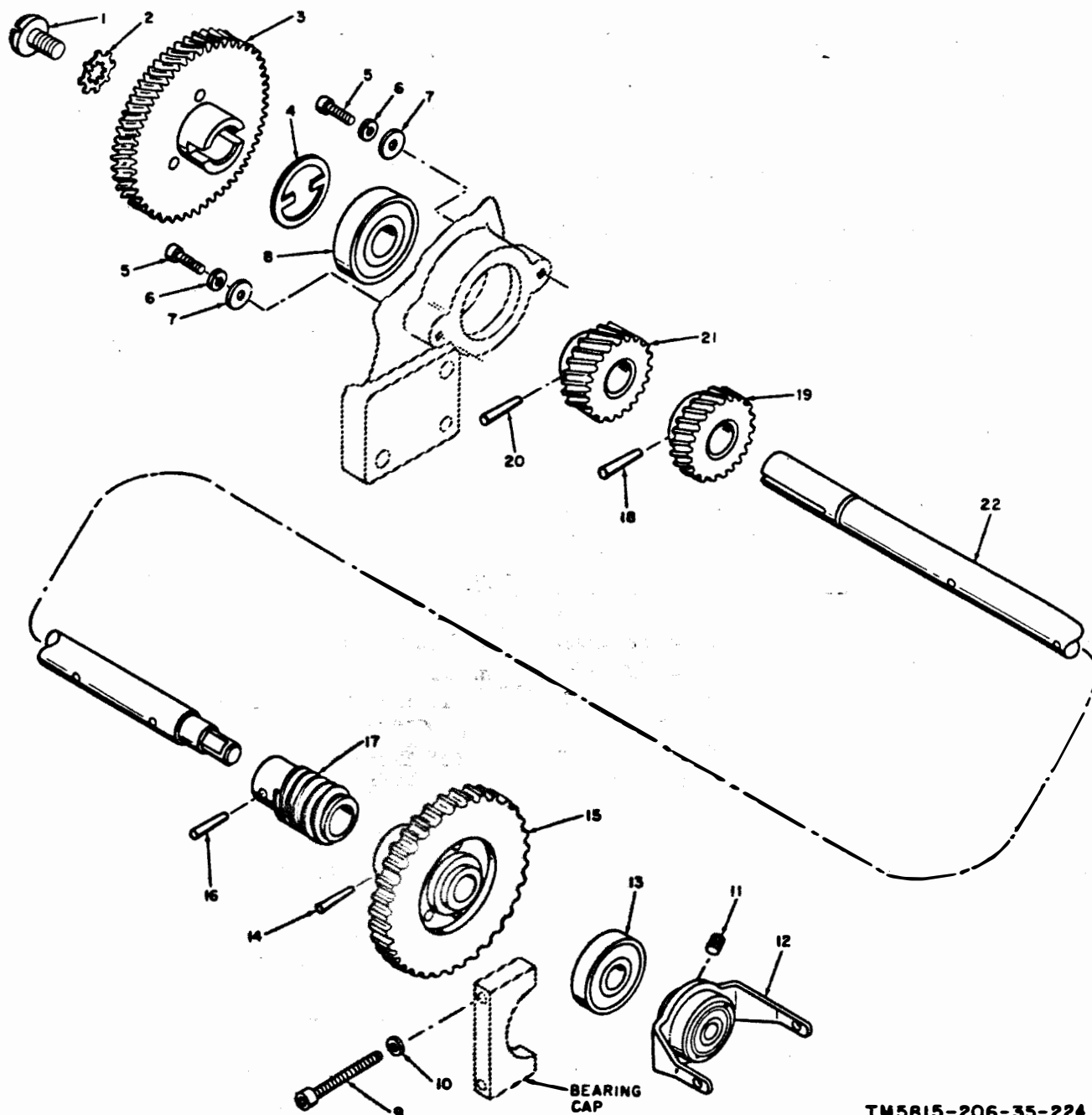

TM5815-206-35-224

- | | | |
|----------------------------|---|---|
| 1. Machine screw, 50207 | 10. Lockwasher, 10430 | 17. Carriage-feed worm, 50268 |
| 2. Lockwasher, 10406 | 11. Setscrew, 10209 | 18. Taper pin, 10852 |
| 3. Main-shaft gear, 50352A | 12. Selector-friction-clutch fork, 50484A | 19. Carriage-return-shaft drive gear, 55167 |
| 4. Drive key, 54566 | 13. Ball bearing, 10757 | 20. Taper pin, 10852 |
| 5. Machine screw, 10003 | 14. Taper pin, 10852 | 21. Transmitter-shaft drive gear, 55166 |
| 6. Lockwasher, 10429 | 15. Function-shaft driving gear, 50354A | 22. Main shaft, 54563 |
| 7. Flat washer, 10450 | 16. Taper pin, 10850 | |
| 8. Ball bearing, 10758 | | |
| 9. Machine screw, 10012 | | |

Figure 105. Main shaft assembly (TT-4B/TG), exploded view.

b. Reassembly.

- (1) Reassemble the main shaft assembly as indicated in figure 105; the se-

quence for assembling the parts is the reverse of the disassembly sequence.

- (2) Replace the main shaft assembly (par. 102b).

104. Removal and Replacement of Code-Ring Cage

a. Removal.

- (1) Remove the four setscrews (10, fig. 101) and the stop-arm shaft and square-shaft stop arm (4 and 5, fig. 106 or 107).
- (2) On the TT-4B/TG, remove the three machine screws (6, fig. 107), flat washers (7), and lockwashers (8) that hold the two fulcrums (line-feed and carriage-return functions) (9), the fulcrum (figures-shift) (10), and the bracket (13) to the function stop-bar guide (15); remove the three fulcrums and the bracket.
- (3) Remove the sensing levers (par. 69a).
- (4) Remove the two machine screws and lockwashers (1 and 2, figs. 106 and 107) that hold the code-ring cage to the selector side of the frame.
- (5) Remove the code-ring cage by pulling it away from the teletypewriter casting.

b. Replacement.

- (1) Position the code-ring cage on the selector side of the teletypewriter frame.
- (2) Replace the sensing levers (par. 69b).
- (3) On the TT-4B/TG, position the two fulcrums (line-feed and carriage-return functions) (9, fig. 107), fulcrum (figures-shift) (10), and bracket (13) on the code-ring cage. Secure them with the three machine screws (6), flat washers (7), and lockwashers (8).
- (4) Insert the stop-arm shaft (5, fig. 106 or 107) in the opening in the center of the code-ring cage and in the hole in the square-shaft driven gear (11, fig. 101). Secure the stop-arm shaft to the gear with the four setscrews (10).
- (5) Install the two machine screws and lockwashers (1 and 2, fig. 106 or 107) that hold the code-ring cage to the selector side of the frame.
- (6) Adjust the code-ring cage (pars. 141, 156, 157 through 161, and 221).

105. Disassembly and Reassembly of Code-Ring Cage (TT-4A/TG) (fig. 106)

a. Disassembly.

- (1) Remove the code-ring cage from the frame (par. 104a).
- (2) Remove the machine screw (3) that holds the square-shaft stop arm (4) to the stop-arm shaft (5); remove the square-shaft stop arm.
- (3) Remove the two machine screws (6) and lockwashers (7) that hold the function stop-bar guide (9) to the cage outer guide (14); remove the dowels (8) and the function stop-bar guide.
- (4) Remove the 19 stop-bar springs (10) from the 32 stop bars (11) and from the three stop bars (12); remove the stop bars.
- (5) Remove the three self-locking hexagonal nuts (13) that hold the cage outer guide (14) to the code-ring cage plate (27); remove the cage outer guide.
- (6) Remove alternately the five spacers (15, 17, 19, 21, and 23) and the five code rings (16, 18, 20, 22, and 24) from the stud of the code-ring cage plate (27).
- (7) Remove the two setscrews (25) that hold the collar (26) to the stud of the code-ring cage plate (27); remove the collar.

b. Reassembly.

- (1) Reassemble the code-ring cage as indicated in figure 106; the sequence for assembling the parts is the reverse of the disassembly sequence.
- (2) Replace the code-ring cage (par. 104b).

106. Disassembly and Reassembly of Code-Ring Cage (TT-4B/TG) (fig. 107)

a. Disassembly.

- (1) Remove the code-ring cage (par. 104a).
- (2) Remove the machine screw (3) that holds the square-shaft stop arm (4) to the stop-arm shaft (5); remove the square-shaft stop arm.
- (3) Remove the three self-locking hexa-



206-35-224
m, 50268
shaft drive
drive gear,

the parts
disassembly

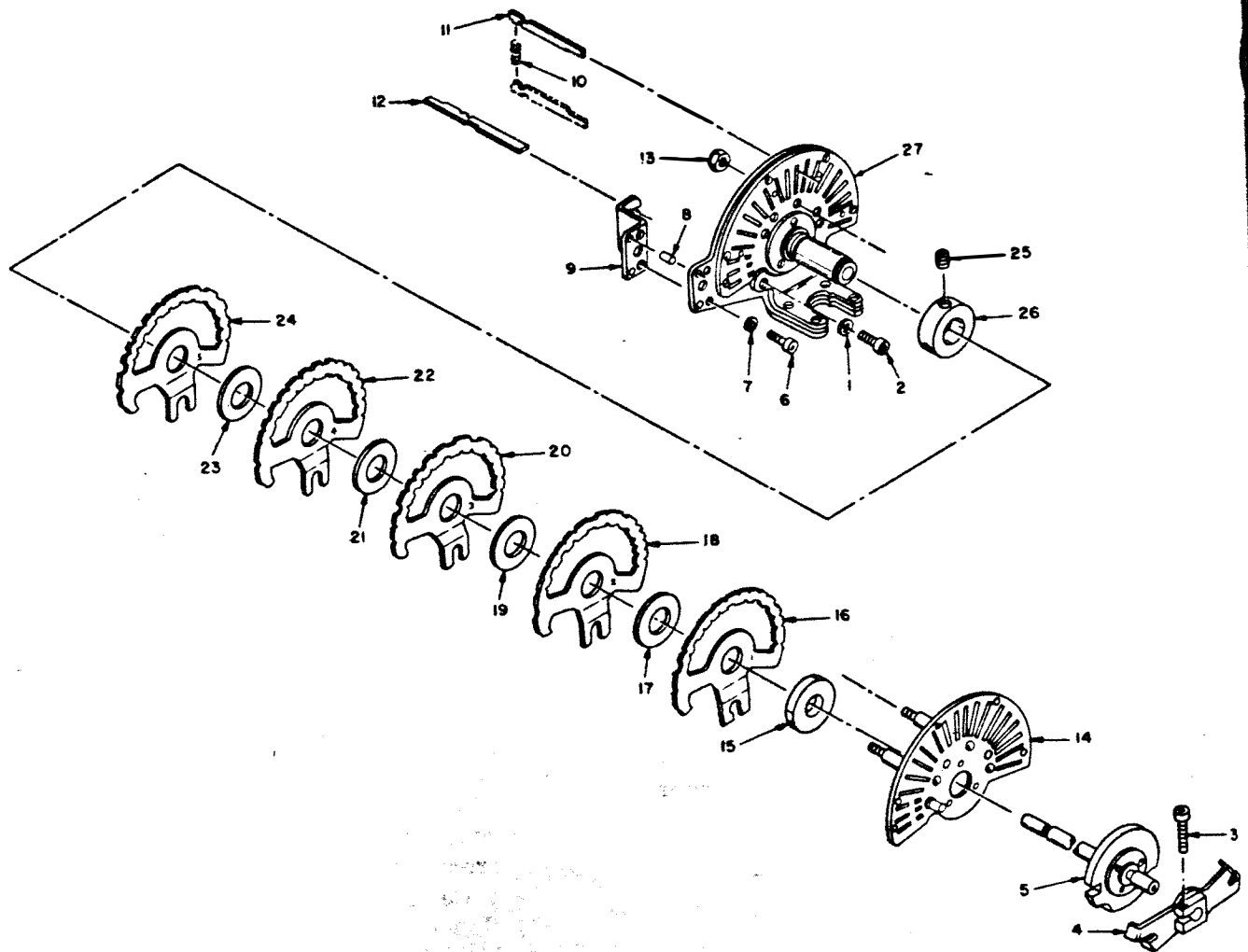

TM5815-206-35-68

- | | | |
|---|--|----------------------------------|
| 1. Machine screw, 10024 | 10. Stop-bar spring, 50154 | 19. Spacer (.029-in.), 51396 |
| 2. Lockwasher, 10405 | 11. Stop bar, 50502 | 20. Code ring, 51633 |
| 3. Machine screw, 10009 | 12. Stop bar, 50503 | 21. Spacer (.029-in.), 51396 |
| 4. Square-shaft stop arm, 53802A
(includes item 3) | 13. Self-locking hexagonal nut,
10500 | 22. Code ring, 51634 |
| 5. Stop-arm shaft, 50377A | 14. Cage outer guide, 51399A | 23. Spacer (.029-in.), 51396 |
| 6. Machine screw, 10002 | 15. Spacer (.134-in.), 51395 | 24. Code ring, 51635 |
| 7. Lockwasher, 10403 | 16. Code ring, 51631 | 25. Setscrew, 10209 |
| 8. Dowel, 50458 | 17. Spacer (.029-in.) 51396 | 26. Collar, 51397 |
| 9. Function stop-bar guide, 50500 | 18. Code ring, 51632 | 27. Code-ring cage plate, 51636A |

Figure 106. Code-ring cage (TT-4A/TG), exploded view.

- (3) Remove the three self-locking hexagonal nuts (11) that hold the eccentric studs (12) to the bracket (13); remove the eccentric studs.
- (4) Remove the two dowels (14) from the function stop-bar guide (15) and from the code-ring cage plate (57); remove the function stop-bar guide.
- (5) Remove the three machine screws (16) and lockwashers (17) that hold the retainer plate (18) to the code-ring cage plate (57); remove the retainer plate.
- (6) Unhook the locking-bail spring (19) from the code-ring locking bail (23) and from the cage outer guide (39).
- (7) Remove the two machine screws (20), flat washers (21), and lockwashers (22) that hold the code-ring locking bail (23) to the locking-bail shaft

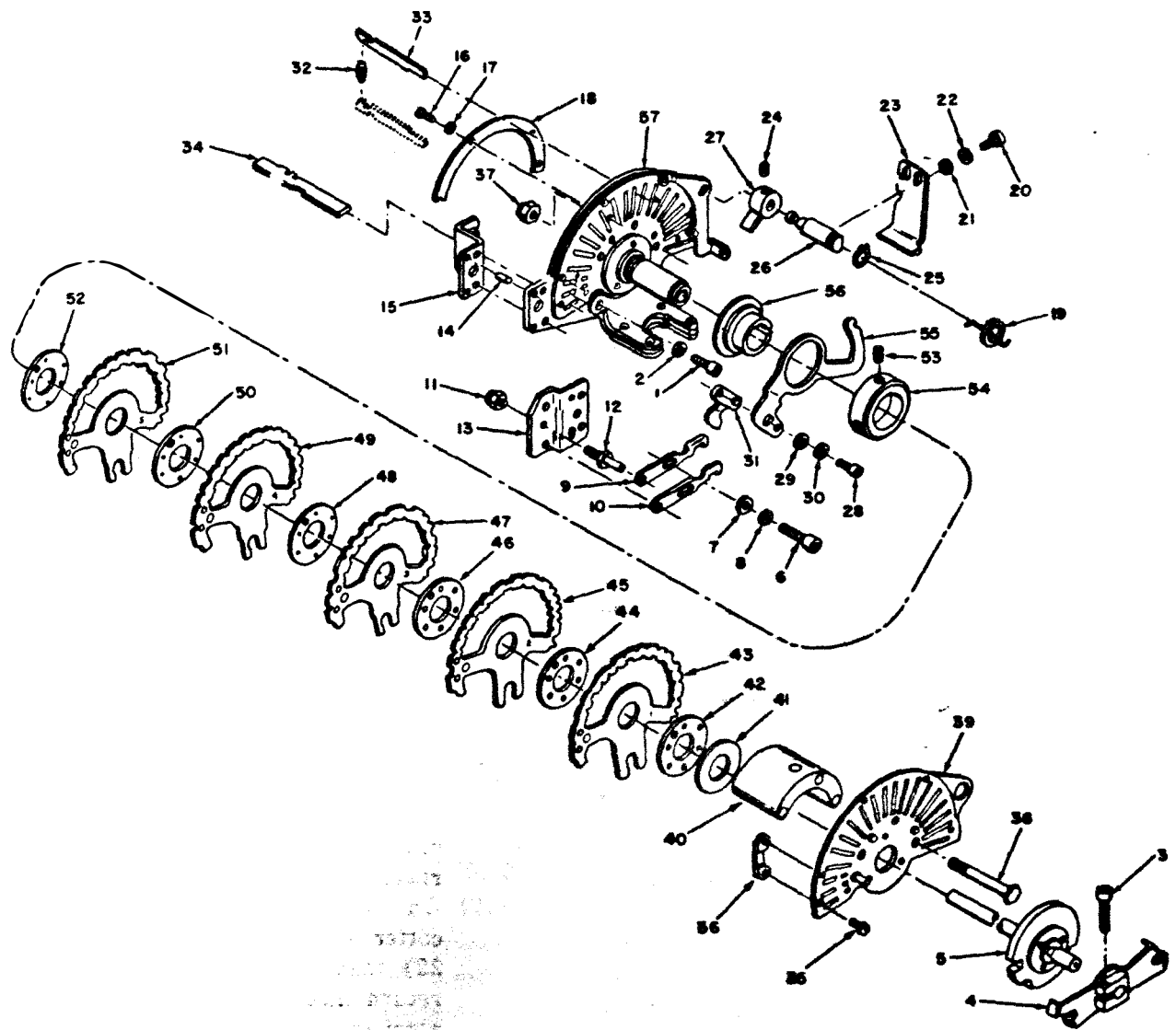

TM5815-206-35-69

- | | | |
|---|---------------------------------------|---|
| 1. Machine screw, 10024 | 19. Locking-bail spring, 57749 | 39. Cage outer guide 53121A (includes item 40) |
| 2. Lockwasher, 10431 | 20. Machine screw, 10004 | 40. Cage spacer, 53445 |
| 3. Machine screw, 10009 | 21. Flat washer, 10459 | 41. Flat washer, 53453 |
| 4. Square-shaft stop arm, 53802A (includes item 3) | 22. Lockwasher, 10429 | 42. Ball retainer, 53647A |
| 5. Stop-arm shaft, 57712A | 23. Code-ring locking bail, 57718 | 43. Code ring, 52356 |
| 6. Machine screw, 10005 | 24. Setscrew, 10201 | 44. Ball retainer, 53647A |
| 7. Flat washer, 10458 | 25. Retainer ring, 10451 | 45. Code ring, 52357 |
| 8. Lockwasher, 10429 | 26. Locking-bail shaft, 53871 | 46. Ball retainer, 53647A |
| 9. Fulcrum, 56178 (line-feed and carriage-return functions) | 27. Locking-bail lever, 53875A | 47. Code ring, 52358 |
| 10. Fulcrum, 56176 (figures-shift function) | 28. Machine screw, 10001 | 48. Ball retainer, 53647A |
| 11. Self-locking hexagonal nut, 10500 | 29. Flat washer, 10459 | 49. Code ring, 52359 |
| 12. Eccentric stud, 55738 | 30. Lockwasher, 10429 | 50. Ball retainer, 53647A |
| 13. Bracket, 55737 | 31. Cam follower, 53882 | 51. Code ring, 52360 |
| 14. Dowel, 50458 | 32. Stop-bar spring, 52940 | 52. Ball retainer, 53647A |
| 15. Function stop-bar guide, 52964 | 33. Stop bar, 50502 | 53. Setscrew, 10223 |
| 16. Machine screw, 10317 | 34. Stop bar, 56179 | 54. Code-ring collar, 52358 |
| 17. Lockwasher, 10433 | 35. Machine screw, 10362 | 55. Cam-follower lever, 53869 |
| 18. Retainer plate, 56177 | 36. Stop bracket, 59332 | 56. Sleeve bearing, 53867 |
| | 37. Self-locking hexagonal nut, 10500 | 57. Code-ring cage plate, 57748 (includes items 14, 15, 39, and 40) |
| | 38. Cage tie bolt, 53972 | |

Figure 107. Code-ring cage (TT-4B/TG), exploded view.

- (26); remove the code-ring locking bail.
- (8) Remove the two setscrews (24) that hold the locking-bail lever (27) to the locking-bail shaft (26).
 - (9) Remove the retainer ring (25) and the locking-bail shaft (26). Catch the locking-bail spring (19) and the locking-bail lever (27) as they fall from the shaft.
 - (10) Remove the machine screw (28), flat washer (29), and lockwasher (30) that hold the cam follower (31) to the cam-follower lever (55); remove the cam follower.
 - (11) Remove the 19 stop-bar springs (32) from the stop bars (33) in the code-ring cage. Remove the 32 stop bars and the three stop bars (34).
 - (12) Remove the two machine screws (35) that hold the stop bracket (36) to the cage outer guide; remove the stop bracket.
 - (13) Remove the three self-locking hexagonal nuts (37) and cage tie bolts (38) that hold the cage outer guide (39) to the code-ring cage plate; remove the cage outer guide and cage spacer (40).
 - (14) Remove the flat washer (41) from the stud on the code-ring cage plate. Remove the six ball retainers (42, 44, 46, 48, 50, and 52) and the five code rings (43, 45, 47, 49, and 51) from the stud on the code-ring cage plate; alternately remove a ball retainer and a code ring until all are removed.
 - (15) Remove the two setscrews (53) that hold the code-ring collar (54) to the stud on the code-ring cage plate (57); remove the code-ring collar, cam-follower lever (55), and sleeve bearing (56) from the code-ring cage plate (57).

b. Reassembly.

- (1) Reassemble the code-ring cage as indicated in figure 107; the sequence for assembling the parts is the reverse of disassembly sequence.
- (2) Replace the code-ring cage (par. 104b).

107. Disassembly and Reassembly of Function Sensing Lever Group (fig. 108)

a. Disassembly.

- (1) Remove the square-shaft assembly (par. 97a).
- (2) Remove the line-feed and platen-shift mechanisms (par. 95a or 96a).
- (3) On the TT-4A/TG, remove the cotter pin (21) and flat washer (22) that hold the adjusting link (2) to the carriage-return clutch actuating lever; disconnect the adjusting link.
- (4) On the TT-4B/TG, remove the retainer ring (1) that holds the adjusting link (2) to the double-blocking lever; disconnect the adjusting link.
- (5) On the TT-4A/TG, remove the cotter pin and flat washer (21 and 22, fig. 108) that hold the horizontal carriage-return link (4) to the stud on the carriage-return bell crank (9); remove the horizontal carriage-return link.
- (6) On the TT-4B/TG, remove the retainer ring (3) that holds the horizontal carriage-return link (4) to the stud on the carriage-return bell crank (9); remove the horizontal carriage-return link.
- (7) On the TT-4A/TG, remove the two cotter pins and flat washers (21 and 22) that hold the vertical carriage-return link (7) to the studs on the carriage-return bell crank (9) and the carriage-return sensing lever (15); remove the vertical carriage-return link.
- (8) On the TT-4B/TG, remove the retainer rings (5 and 6) that hold the vertical carriage-return link (7) to the studs on the carriage-return bell crank (9) and the carriage-return sensing lever (15); remove the vertical carriage-return link.
- (9) On the TT-4A/TG, remove the cotter pin and flat washer that hold the carriage-return bell crank (9) to the carriage-return bell-crank stud (10); remove the carriage-return bell crank.
- (10) On the TT-4B/TG, remove the retainer ring (8) that holds the car-

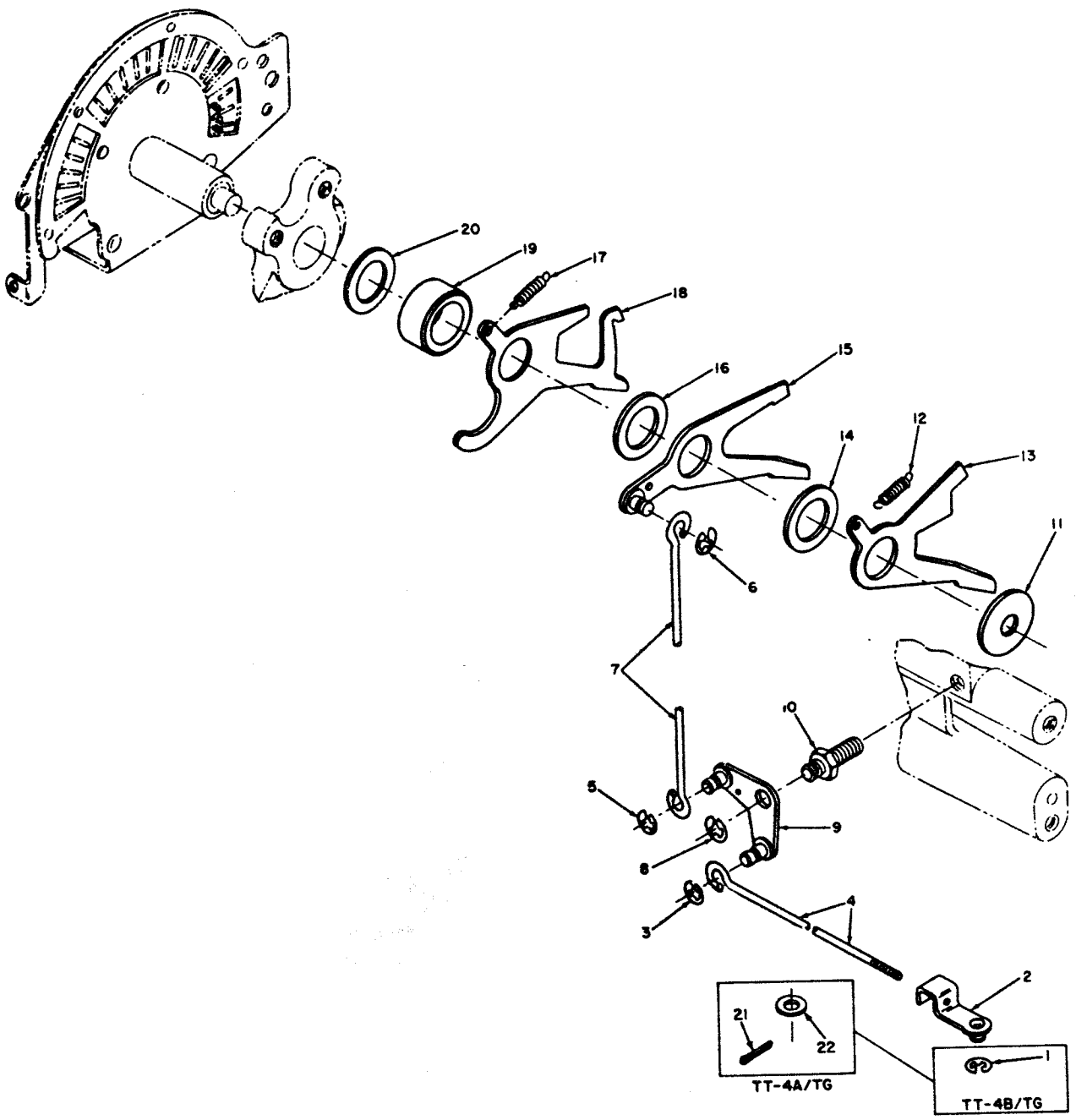

TM5815-206-35-70

- | | | |
|---|---|--|
| 1. Retainer ring, 10960 | 7. Vertical carriage return link, 50483 | 12. Line-feed sensing-lever spring, 51754 |
| 2. Adjusting link, 50863*, 53161A* | 8. Retainer ring, 10949* (cotter pin, 10801, flat washer, 50319)* | 13. Line-feed sensing lever, 53106 |
| 3. Retainer ring, 10960* (cotter pin, 10801, flat washer, 50319)* | 9. Carriage-return bell crank, 50490A*, 52121A* | 14. Flat washer, 50384 |
| 4. Horizontal carriage-return link, 50864 | 10. Carriage-return bell-crank stud, 50543A*, 52552* | 15. Carriage-return sensing lever, 50386*, 52659A* |
| 5. Retainer ring, 10960* (cotter pin, 10801 flat washer, 50319)* | 11. Flat washer, 50374 | 16. Flat washer, 50384 |
| 6. Retainer ring, 10960* (cotter pin, 10801, flat washer, 50319)* | | 17. Figures-shift sensing-lever spring, 51754 |

* Used on TT-4A/TG.

* Used on TT-4B/TG.

Figure 108. Function sensing lever group, exploded view.

Figure 108—Continued

riage-return bell crank (9) to the carriage-return bell-crank stud (10); remove the carriage-return bell crank.

- (11) Remove the carriage-return bell-crank stud (10) from the frame.
- (12) Remove the flat washer (11) from the stoparm shaft.
- (13) Remove the line-feed sensing-lever spring (12) from the line-feed sensing lever (13) and from the bell-crank pivot bracket.
- (14) Remove the line-feed sensing lever (13), flat washer (14), carriage-return sensing lever (15), and flat washer (16) from the stop-arm shaft.
- (15) Remove the figures-shift sensing-lever spring (17) from the figures-shift sensing lever (18) and from the bell-crank pivot bracket.
- (16) Remove the figures-shift sensing lever (18), spacing collar (19), and laminated washer (20) from the stop-arm shaft.

b. Reassembly.

- (1) Reassemble the function sensing lever group as indicated in figure 108; the sequence for assembling the parts is the reverse of the disassembly sequence.
- (2) Replace the line-feed and platen-shift mechanisms (par. 95b or 96b).
- (3) Replace the square-shaft assembly (par. 97b).
- (4) Adjust the function sensing lever group (pars. 155 through 157).

108. Disassembly and Reassembly of Manual Carriage-Return Mechanism (fig. 109)

a. Disassembly.

- (1) Remove one paper-shaft bracket and the paper chute (par. 58a).
- (2) Unscrew the manual carriage-return button (1) from the manual carriage-return link (4).
- (3) Remove the cotter pin (2) and flat washer (3) that hold the manual carriage-return link (4) to the stud on

the manual carriage-return lever (8); remove the manual carriage-return link.

- (4) Remove the trip-pawl spring (5) from the trip pawl on the manual carriage-return lever (8) and from the spring post on the manual carriage-return bracket (13).
- (5) Remove the cotter pin (6) and flat washer (7) that hold the manual carriage-return lever (8) to the stud on the manual carriage-return bracket (13); remove the manual carriage-return lever.
- (6) Remove the plain hexagonal nut (9) from the setscrew (10); remove the setscrew from the manual carriage-return bracket (13).
- (7) Remove the two machine screws (11) and lockwashers (12) that hold the manual carriage-return bracket (13) to the frame; remove the manual carriage-return bracket.

b. Reassembly.

- (1) Reassemble the manual carriage-return mechanism as indicated in figure 109; the sequence for assembling the parts is the reverse of the disassembly sequence.
- (2) Adjust the manual carriage-return mechanism (pars. 248, 249, or 250).
- (3) Replace the paper-shaft bracket and paper chute (par. 58b).

109. Disassembly and Reassembly of Carriage-Feed Mechanism (TT-4A/TG)

(fig. 110)

a. Disassembly.

- (1) Remove the cotter pin (3, fig. 98) and flat washer (4) that hold the carriage-feed link (4, fig. 110) to the carriage-feed lever (26, fig. 98); remove the carriage-feed link from the carriage-feed lever.
- (2) Remove the cotter pin (1, fig. 110) and flat washer (2) that hold the adjusting link (3) to the stud on the

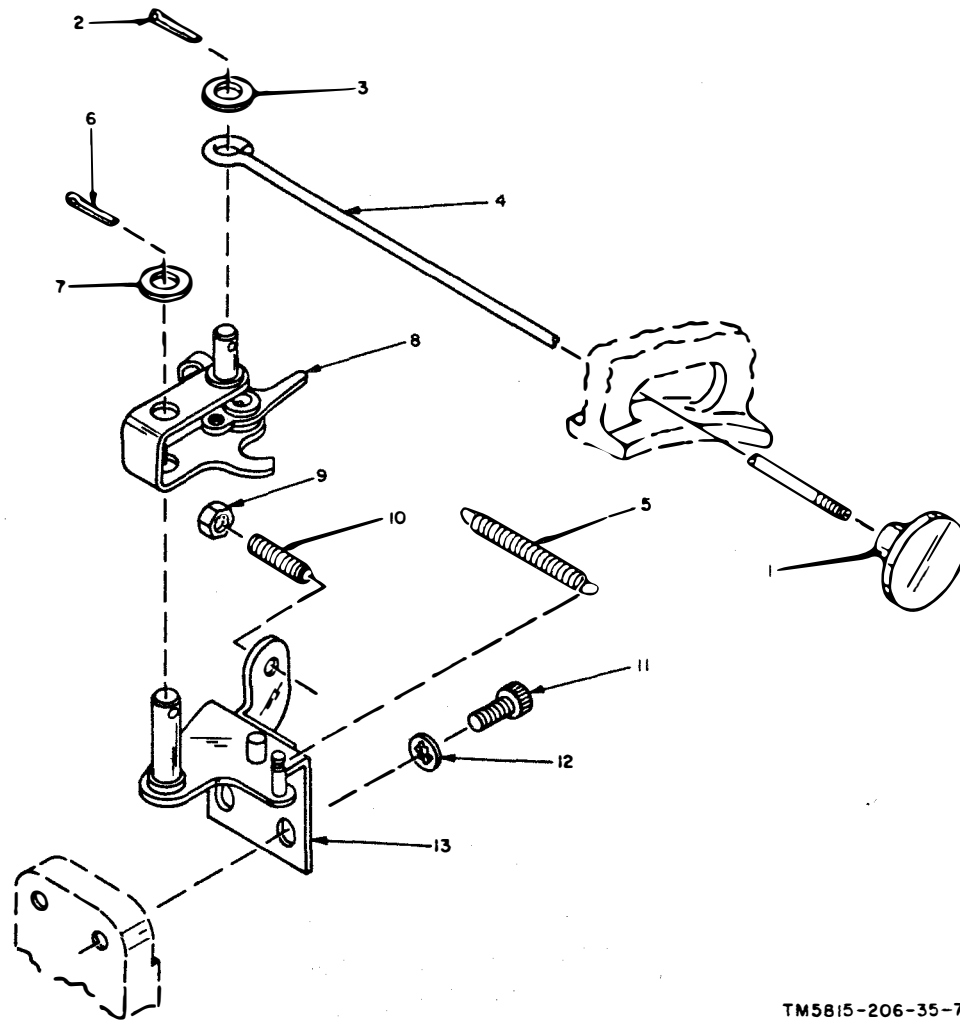

TM5815-206-35-71

- | | | |
|---|---|--|
| 1. Manual carriage-return button, 50335 | 5. Trip-pawl spring, 52164 | 10. Setscrew, 10206 |
| 2. Cotter pin, 10801 | 6. Cotter pin, 10801 | 11. Machine screw, 10008 |
| 3. Flat washer, 50319 | 7. Flat washer, 50315 | 12. Lockwasher, 10404 |
| 4. Manual carriage-return link, 50530 | 8. Manual carriage-return lever, 50155A | 13. Manual carriage-return bracket, 50180A |
| | 9. Plain hexagonal nut, 10505 | |

Figure 109. Manual carriage-return mechanism, exploded view.

carriage-feed pawl (8); remove the adjusting link. Remove the adjusting link (3) from the carriage-feed link (4).

- (3) Remove the carriage-feed-pawl spring (5) from the carriage-feed pawl (8) and from the spring post on the frame.
- (4) Remove the self-locking hexagonal nut (6) and the flat washer (7) that hold the carriage-feed pawl (8) to the pawl mounting stud (9); remove the carriage-feed pawl and the pawl mounting stud.
- (5) Remove the carriage-feed clutch-lever

spring (10) from the carriage-feed-clutch lever (13) and from the spring post on the teletypewriter frame.

- (6) Remove the cotter pin (11) and flat washer (12) that hold the carriage-feed-clutch lever (13) to the carriage-feed clutch-lever stud (15); remove the carriage-feed-clutch lever.
- (7) Remove the setscrew (14) that holds the carriage-feed clutch-lever stud (15) in the frame; remove the carriage-feed clutch-lever stud.

b. Reassembly.

- (1) Reassemble the carriage-feed mecha-

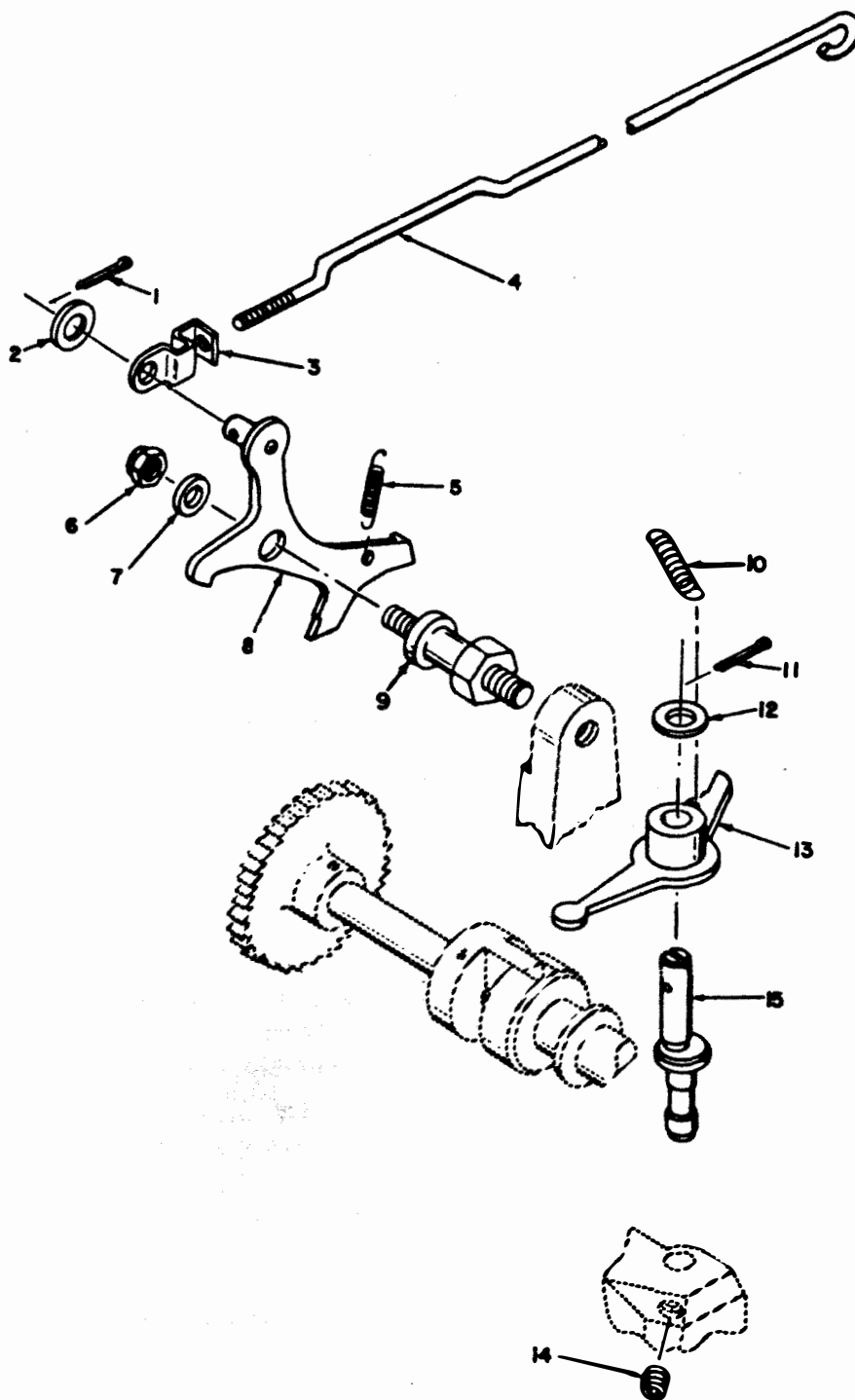

TM5815-206-35-72

Figure 110. Carriage-feed mechanism (TT-4A/TG), exploded view.

- | | | |
|-----------------------|------------------------------|-------------------------------------|
| 1. Cotter pin, 10801 | 3. Adjusting link, 51782 | 5. Carriage-feed-pawl spring, 50912 |
| 2. Flat washer, 50319 | 4. Carriage-feed link, 51782 | |

- | | | |
|--------------------------------------|--|--|
| 6. Self-locking hexagonal nut, 10500 | 10. Carriage-feed clutch-lever spring, 50911 | 13. Carriage-feed-clutch lever, 50005A |
| 7. Flat washer, 50414 | 11. Cotter pin, 10801 | 14. Setscrew, 10204 |
| 8. Carriage-feed pawl, 51676A | 12. Flat washer, 50315 | 15. Carriage-feed clutch-lever stud, 50208 |
| 9. Pawl mounting stud, 50507 | | |

Figure 110—Continued

nism as indicated in figure 110; the sequence for assembling the parts is the reverse of the disassembly sequence.

- (2) Adjust the carriage-feed mechanism (par. 212).

110. Disassembly and Reassembly of Carriage-Feed Mechanism (TT-4B/TG)

(fig. 111)

a. Disassembly.

- (1) Remove the retainer ring that holds the carriage-feed link (3) to the carriage-feed lever (26, fig. 98); remove the carriage-feed link from the carriage-feed lever.
- (2) Remove the retainer ring (1, fig. 111) that holds the adjusting link (2) to the stud on the carriage-feed pawl (9); remove the adjusting link. Remove the adjusting link from the carriage-feed link.
- (3) Remove the carriage-feed-pawl spring (4) from the carriage-feed pawl (9) and from the spring post on the frame.
- (4) Remove the two machine screws (5) and lockwashers (6) that hold the assembled carriage-feed pawl (9) and pawl mounting bracket (11) to the frame; remove the assembled carriage-feed pawl and pawl mounting bracket.
- (5) Remove the self-locking hexagonal nut (7) and flat washer (8) that hold the carriage-feed pawl (9) to the pawl mounting bracket (11); remove the carriage-feed pawl, spacer (17), and flat washer (10).
- (6) Remove the carriage-feed clutch-lever spring (12) from the carriage-feed-clutch lever (14) and from the spring post on the frame.
- (7) Remove the retainer ring (13) that holds the carriage-feed-clutch lever (14) to the carriage-feed clutch-lever

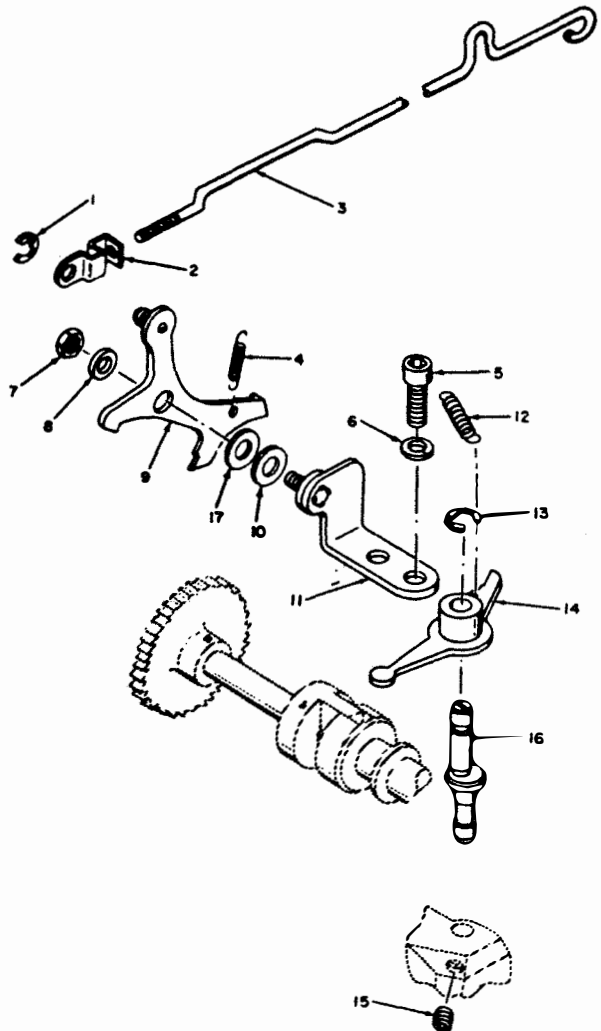

TM5815-206-35-73

- | | |
|--------------------------------------|--|
| 1. Retainer ring, 10960 | 10. Flat washer, 50827 |
| 2. Adjusting link, 51783 | 11. Pawl mounting bracket, 55788A |
| 3. Carriage-feed link, 55504 | 12. Carriage-feed clutch-lever spring, 50911 |
| 4. Carriage-feed-pawl spring, 50912 | 13. Retainer ring, 10949 |
| 5. Machine screw, 10025 | 14. Carriage-feed-clutch lever, 50005A |
| 6. Lockwasher, 10430 | 15. Setscrew, 10204 |
| 7. Self-locking hexagonal nut, 10500 | 16. Carriage-feed clutch-lever stud, 52318 |
| 8. Flat washer, 10450 | 17. Spacer (.032-in.), 50831 |
| 9. Carriage-feed pawl, 52138A | |

Figure 111. Carriage-feed mechanism (TT-4B/TG), exploded view.

stud (16); remove the carriage-feed-clutch lever.

- (8) Remove the setscrew (15) that holds the carriage-feed clutch-lever stud (16) in the frame; remove the carriage-feed clutch-lever stud.

b. Reassembly.

- (1) Reassemble the carriage-feed mechanism as indicated in figure 111; the sequence for assembling the parts is the reverse of the disassembly sequence.
- (2) Adjust the carriage-feed mechanism (pars. 210 and 212).

111. Removal and Replacement of Carriage-Return Operating Mechanism

a. Removal.

- (1) Remove the horizontal carriage-return link (4, fig. 108) as described in paragraph 107a(6) or (7).
- (2) Remove the two machine screws (1, fig. 112) and lockwashers (2) that hold the assembled carriage-return operating mechanism on the frame; remove the mechanism.

b. Replacement.

- (1) Position the assembled carriage-return operating mechanism on the teletypewriter frame so that the carriage-return-clutch lever (10) engages the groove in the carriage-return-clutch drum (3, fig. 119). Secure the carriage-return operating mechanism to the teletypewriter with two machine screws (1, fig. 112) and lock washers (2).
- (2) Install the horizontal carriage-return link (par. 107b).
- (3) Adjust the carriage-return operating mechanism (pars. 216 through 218).

112. Disassembly and Reassembly of Carriage-Return Operating Mechanism (TT-4A/TG)

(fig. 112)

a. Disassembly.

- (1) Remove the carriage-return operating mechanism (par. 111a).
- (2) Remove the lever spring (3) from the carriage-return clutch latch lever (6)

and from the latch mounting plate (7).

- (3) Remove the cotter pin (4) and flat washer (5) that hold the carriage-re-

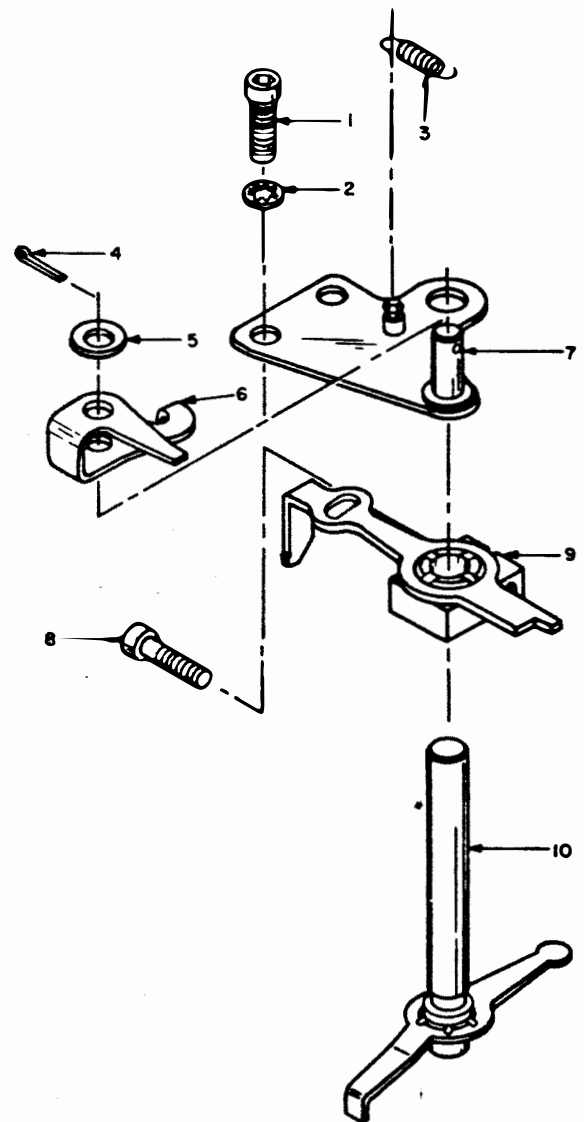

TM5815-206-35-74

- | | |
|--|--|
| 1. Machine screw, 10008 | 7. Latch mounting plate, 50001A |
| 2. Lockwasher, 10404 | 8. Machine screw, 10009 |
| 3. Lever spring, 50946 | 9. Carriage-return operating lever, 51682A (includes item 8) |
| 4. Cotter pin, 10801 | 10. Carriage-return-clutch lever, 50008A |
| 5. Flat washer, 50315 | |
| 6. Carriage-return clutch latch lever, 50011 | |

Figure 112. Carriage-return operating mechanism (TT-4A/TG), exploded view.

turn clutch latch lever (6) to the stud on the latch mounting plate (7); remove the carriage-return clutch latch lever.

(4) Remove the latch mounting plate (7) from the shaft of the carriage-return-clutch lever (10).

(5) Remove the machine screw (8) that

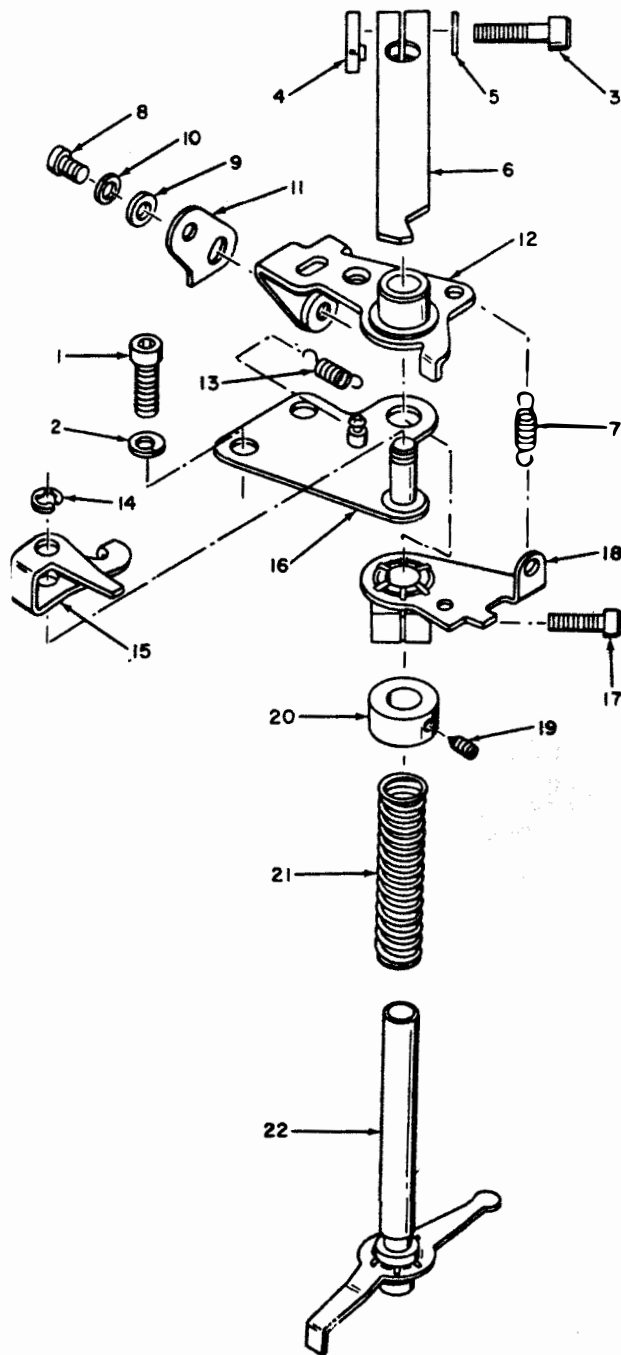

- | | |
|---|---|
| 1. Machine screw, 10008 | 14. Retainer ring, 10949 |
| 2. Lockwasher, 10430 | 15. Carriage-return latch, 50011 |
| 3. Machine screw, 10011 | 16. Latch mounting plate, 53163A |
| 4. Clamp nut, 52073 | 17. Machine screw, 10009 |
| 5. Flat washer, 10467 | 18. Carriage-return-clutch actuating-lever, 56241A (includes item 17) |
| 6. Throw-out lever, 56283 | 19. Setscrew, 10209 |
| 7. Carriage-return-clutch actuating-lever spring, 56258 | 20. Shaft collar, 50209 |
| 8. Machine screw, 10003 | 21. Carriage-return-clutch-lever spring, 52259 |
| 9. Flat washer, 10458 | 22. Carriage-return-clutch lever, 56243A |
| 10. Lockwasher, 10429 | |
| 11. Adjusting plate, 56265A | |
| 12. Double-blocking lever, 56265A | |
| 13. Double-blocking-lever spring, 50946 | |

Figure 113—Continued

locks the carriage-return operating lever (9) to the shaft of the carriage-return-clutch lever; remove the carriage-return operating lever.

b. Reassembly.

- (1) Reassemble the carriage-return operating mechanism as indicated in figure 112; the sequence for assembling the parts is the reverse of the disassembly sequence.
- (2) Replace the carriage-return operating mechanism (par. 111b).

113. Disassembly and Reassembly of Carriage-Return Operating Mechanism (TT-4B/TG)

(fig. 113)

a. Disassembly.

- (1) Remove the carriage-return operating mechanism (par. 111a).
- (2) Remove the machine screw (3), clamp nut (4), and flat washer (5) that lock the throw-out lever (6) to the shaft of the carriage-return-clutch lever (22); remove the throw-out lever.
- (3) Remove the carriage-return-clutch actuating-lever spring (7) from the double-blocking lever (12) and from the carriage-return-clutch actuating lever (18).
- (4) Remove the assembled double-blocking lever and adjusting plate (11) from the shaft of the carriage-return-clutch lever (22).
- (5) Remove the machine screw (8), flat washer (9), and lockwasher (10) that

TM5815-206-35-191

Figure 113. Carriage-return operating mechanism (TT-4B/TG), exploded view.

hold the adjusting plate (11) to the double-blocking lever; remove the adjusting plate.

- (6) Remove the double-blocking-lever spring (13) from the carriage-return latch (15) and from the latch mounting plate (16).
- (7) Remove the retainer ring (14) that secures the carriage-return latch (15) to the stud on the latch mounting plate (16); remove the carriage-return latch.
- (8) Remove the latch mounting plate (16) from the shaft of the carriage-return-clutch lever.
- (9) Remove the machine screw (17) that locks the carriage-return-clutch actuating lever (18) to the shaft of the carriage-return-clutch lever (22); remove the carriage-return-clutch actuating lever.
- (10) Remove the two setscrews (19) that lock the shaft collar (20) to the shaft of the carriage-return-clutch lever (22); remove the collar and the carriage-return-clutch-lever spring (21).

b. Reassembly.

- (1) Reassemble the carriage-return operating mechanism as indicated in figure 113; the sequence for assembling the parts is the reverse of the disassembly sequence.
- (2) Replace the carriage-return operating mechanism (par. 111*b*).
- (3) Adjust the carriage-return operating mechanism (pars. 199, 200, 201, 204, 210, 214, 215, and 220).

114. Disassembly and Reassembly of Carriage-Rack Drive-shaft Assembly (fig. 114)

a. Disassembly.

- (1) Remove the paper-shaft bracket and the paper chute (par. 58*a*).
- (2) Remove the mounting hardware for the instrument panel (par. 65*a*).
- (3) Remove the keyboard-transmitter (par. 61*a*).
- (4) Remove the carriage assembly (par. 63*a*).
- (5) On the TT-4A/TG, remove the plain hexagonal nut (3), lockwasher (4),

and adjusting stud (5) from the carriage-return adjusting collar (7).

- (6) On the TT-4A/TG, remove the two setscrews (6) that lock the carriage-return adjusting collar (7) to the carriage-rack driving gear and shaft (45); remove the carriage-return adjusting collar and flat washer (8).
- (7) Remove the carriage-return blocking lever spring (9) from the two blocking levers (10 and 12) of the TT-4A/TG.
- (8) Remove the carriage-return blocking lever (10), flat washer (11), and carriage-feed blocking lever (12) from the shaft of the carriage-rack driving gear and shaft of the TT-4A/TG.
- (9) Remove the two setscrews (13) that lock the collar (14) to the shaft of the carriage-rack driving gear and shaft of the TT-4A/TG; remove the collar.
- (10) On the TT-4B/TG, remove the two machine screws (1) and lockwashers (2) that hold the bearing cap (46) to the front of the frame.
- (11) On the TT-4B/TG, remove the machine screw (15), lock washer (16), and flat washer (17) from the carriage-return adjusting collar (20).
- (12) Remove the two setscrews (18 and 19) that lock the carriage-return adjusting collar (20) of the TT-4B/TG to the shaft of the carriage-rack driving gear and shaft; remove the carriage-feed adjusting lever (21) and flat washer (22) from the shaft.
- (13) Remove the carriage-return blocking-lever spring (23) from the two blocking levers (24 and 27) of the TT-4B/TG.
- (14) Remove the carriage-return blocking lever (24), flat washer (25), spacer (26), and carriage-feed blocking lever (27) from the shaft of the carriage-rack driving gear and shaft of the TT-4B/TG.
- (15) Remove the two setscrews (28 and 29) that lock the collar (30) of the TT-4B/TG to the carriage-rack driving gear and shaft; remove the collar from the shaft.

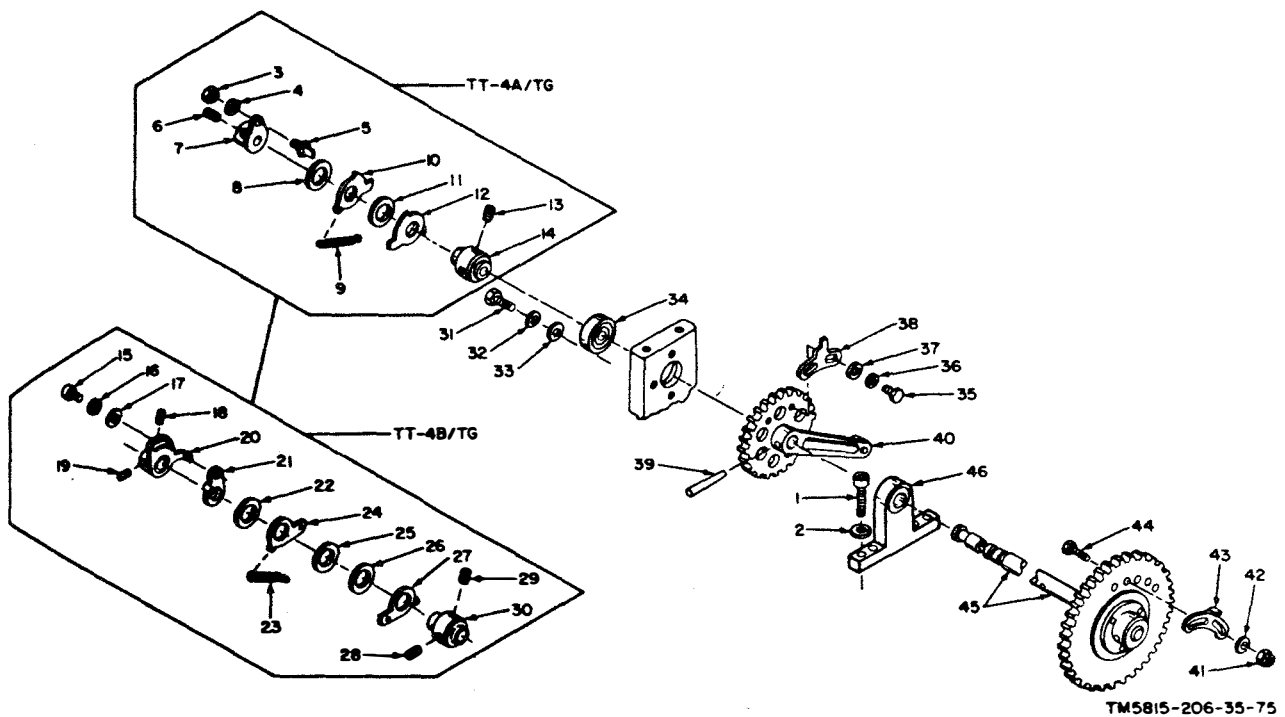

- | | | |
|---|--|--|
| 1. Machine screw, 10011* | 16. Lockwasher, 10429 | 30. Collar, 57715 |
| 2. Lockwasher, 10430* | 17. Flat washer, 10458 | 31. Machine screw, 10003 |
| 3. Plain hexagonal nut, 10513 | 18. Setscrew, 10209 | 32. Lockwasher, 10429 |
| 4. Lockwasher, 10403 | 19. Setscrew, 10223 | 33. Flat washer, 10458 |
| 5. Adjusting stud, 51673 | 20. Carriage-return adjusting collar, 55090 | 34. Ball bearing, 10759 |
| 6. Setscrew, 10208 | 21. Carriage-feed adjusting lever, 53787 | 35. Machine screw, 10303 |
| 7. Carriage-return adjusting collar, 51671 | 22. Flat washer, 51681 | 36. Lockwasher, 10429 |
| 8. Flat washer, 51670 | 23. Carriage-return blocking-lever spring, 50916 | 37. Flat washer, 10458 |
| 9. Carriage-return blocking-lever spring, 50916 | 24. Carriage-return blocking lever, 53785 | 38. Latch-tripping arm, 55524 |
| 10. Carriage-return blocking lever, 51669 | 25. Flat washer, 57717 | 39. Taper pin, 10850 |
| 11. Flat washer, 51681 | 26. Spacer (.062-in.), 55652 | 40. Carriage-return driven gear, 51747A |
| 12. Carriage-feed blocking lever, 51669 | 27. Carriage-feed blocking lever, 53785 | 41. Self-locking hexagonal nut, 10500 |
| 13. Setscrew, 10209 | 28. Setscrew, 10209 | 42. Flat washer, 10450 |
| 14. Collar, 51668 | 29. Setscrew, 10223 | 43. Pawl tripping arm, 50124 |
| 15. Machine screw, 10002 | | 44. Machine screw, 10080 |
| | | 45. Carriage-rack driving gear and shaft, 51741*, 55520* |
| | | 46. Bearing cap* |

* Used on TT-4A/TG.

* Used on TT-4B/TG.

Figure 114. Carriage-rack drive-shaft assembly, exploded view.

- (16) Remove the two machine screws (31), lockwashers (32), and flat washers (33) that hold the ball bearing (34) in the bearing housing in the frame; pull the carriage-rack driving gear and shaft forward until it clears the ball bearing, and remove the ball bearing.
- (17) Remove the two machine screws (35), lockwashers (36), and flat washers (37) that hold the latch-tripping arm (38) to the carriage-return driven gear (40); remove the latch-tripping arm from the gear.
- (18) Remove the taper pin (39) that locks the carriage-return driven gear (40) to the shaft of the carriage-rack driving gear and shaft (45); remove the carriage-return driven gear.
- (19) On the TT-4B/TG, remove the assembled carriage-rack driving gear and shaft (45) and the pawl tripping arm (43) from the bearing cap (46).
- (20) Remove the two self-locking hexagonal nuts (41), flat washers (42), and machine screws (44) that hold the pawl tripping arm (43) to the gear

of the carriage-rack driving gear and shaft (45); remove the pawl tripping arm from the gear.

b. Reassembly.

- (1) Reassemble the carriage-rack drive-shaft assembly as indicated in figure 114; the sequence for assembling the parts is the reverse of the disassembly sequence.
- (2) Install the carriage assembly (par. 63b).
- (3) Install the keyboard-transmitter (par. 61b).
- (4) Install the instrument panel (par. 65b).
- (5) Install the paper-shaft bracket and the paper chute (par. 58b).
- (6) Adjust the carriage-rack-shaft assembly (pars. 203, 206, and 209 through 212).

115. Disassembly and Reassembly of Margin-Bell Assembly (fig. 115)

a. Disassembly.

- (1) Remove the two machine screws (1) and lockwashers (2) that hold the margin-bell assembly to the frame; remove the margin-bell assembly.
- (2) Remove the margin-bell-clapper spring (3) from the margin-bell clapper (8) and from the spring post on the margin-bell bracket (13).
- (3) On the TT-4A/TG, remove the cotter pin (5) and flat washer (6) that hold the margin-bell clapper (8) to the margin-bell bracket (13); remove the margin-bell clapper.
- (4) On the TT-4B/TG, remove the retainer ring (4) that holds the margin-bell clapper (8) to the margin-bell bracket (13); remove the margin-bell clapper.
- (5) Remove the margin-bell-pawl spring (7) from the margin-bell clapper (8).
- (6) Remove the self-locking hexagonal nut (9), machine screw (10), and lockwasher (11) that hold the margin bell (12) to the margin-bell bracket (13); remove the bell from the bracket.

b. Reassembly.

- (1) Reassemble the margin-bell assembly

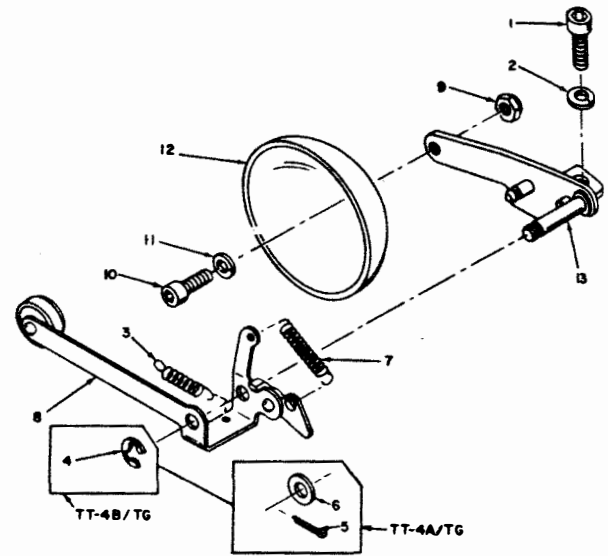

- | | |
|---|--|
| 1. Machine screw, 10008 | 8. Margin-bell clapper, 50244A |
| 2. Lockwasher, 10404*, 10430 ^b | 9. Self-locking hexagonal nut, 10500 |
| 3. Margin-bell-clapper spring, 50231 | 10. Machine screw, 10003 |
| 4. Retainer ring, 10960 | 11. Lockwasher, 10403*, 10429 ^b |
| 5. Cotter pin, 10801 | 12. Margin bell, 51403 |
| 6. Flat washer, 50319 | 13. Margin-bell bracket, 50224A*, 53164A* |
| 7. Margin-bell-pawl spring, 50232 | |

Figure 115. Margin-bell assembly, exploded view.

as indicated in figure 115; the sequence for assembling the parts is the reverse of the disassembly sequence.

- (2) Adjust the margin-bell assembly (par. 247).

116. Removal and Replacement of Carriage-Feed Shaft Assembly (fig. 116)

a. Removal.

- (1) Remove the instrument panel (par. 65a).
- (2) Remove the paper shaft, one paper-shaft bracket, and the paper chute (par. 58a).
- (3) Remove the carriage-feed mechanism (pars. 109a or 110a).
- (4) Remove the margin-bell assembly (par. 115a(1)).
- (5) Remove the machine screw (1) and lockwasher (2) that hold the assembled bearing block and ball bearing

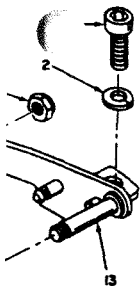

(6) to the frame; remove the assembled bearing block and ball bearing.

- (6) Remove the two machine screws (3), lockwashers (5), and flat washers (4) that hold the ball bearing (6) in the bearing block; remove the ball bearing.
- (7) Remove the two machine screws (7), lockwashers (9), and flat washers (8) from the teletypewriter frame. On the TT-4B/TG, remove the bearing retainer (10).
- (8) Remove the self-locking hexagonal nut (11) from the end of the carriage-feed shaft (38).
- (9) On the TT-4B/TG, pull the carriage-feed shaft far enough forward to clear the ball bearing. Remove the carriage-feed shaft from the teletypewriter.
- (10) On the TT-4A/TG, remove the setscrews (15, 20, 29, and 34) that hold the shaft collar (16), friction-adjusting collar (21), carriage-feed ratchet (30), and drive collar (35) to the carriage-feed shaft. Remove the flat washer (13) and adjusting nut (14), and withdraw the shaft from the front of the teletypewriter; catch the loose parts as they fall from the shaft.
- (11) Remove the ball bearing (12) from the bearing seat in the teletypewriter frame.

b. Replacement.

- (1) Replace the carriage-feed shaft assembly as indicated in figure 116; the sequence for replacing the parts is the reverse of the removal sequence.
- (2) Replace the carriage-feed mechanism (par. 109b or 110b).
- (3) Replace the platen (par. 62b).
- (4) Replace the keyboard-transmitter (par. 61b).
- (5) Adjust the carriage-feed shaft assembly (pars. 194, 195, 197, and 202).

117. Disassembly and Reassembly of Carriage-Feed Shaft Assembly
(fig. 116)

a. Disassembly.

- (1) Remove the carriage-feed shaft assembly (par. 116a).
- (2) Remove the flat washer (13) and the

adjusting nut (14) from the carriage-feed shaft (38). Loosen the two setscrews (15) that lock the shaft collar (16) to the carriage-feed shaft, and remove the shaft collar.

- (3) Slide the carriage-feed gear and fork (17) from the clutch driving disk (27) and the carriage-feed shaft.
- (4) Loosen the machine screw (18) that locks the friction-adjusting collar (19) to the carriage-feed shaft; back off and remove the collar.
- (5) Remove the two setscrews (22) that lock the drive collar (23) to the carriage-feed shaft; remove the drive collar.
- (6) Remove the friction-clutch spring (24), friction-clutch disk (25), felt friction plate (26), clutch driving disk (27), and felt friction plate (28) from the carriage-feed shaft.
- (7) Remove the two setscrews (29) that lock the carriage-feed ratchet (30) to the carriage-feed shaft; remove the ratchet.
- (8) Remove the carriage-feed driving gear (31), flat washer (32), and carriage-feed-clutch drum (33) from the carriage-feed shaft.
- (9) Remove the setscrew that locks the drive collar (37) to the carriage-feed shaft (38); remove the shaft collar.

b. Reassembly.

- (1) Reassemble the carriage-feed shaft assembly as indicated in figure 116; the sequence for assembling the parts is the reverse of the disassembly sequence.
- (2) Install the carriage-feed shaft assembly (par. 116b).

118. Disassembly and Reassembly of Carriage-Return Shaft Assembly
(TT-4A/TG)

(fig. 117)

a. Disassembly.

- (1) Remove one paper-shaft bracket and the paper chute (par. 58a).
- (2) Remove the keyboard-transmitter (par. 61a).
- (3) Remove the carriage-return operating mechanism (par. 111a).

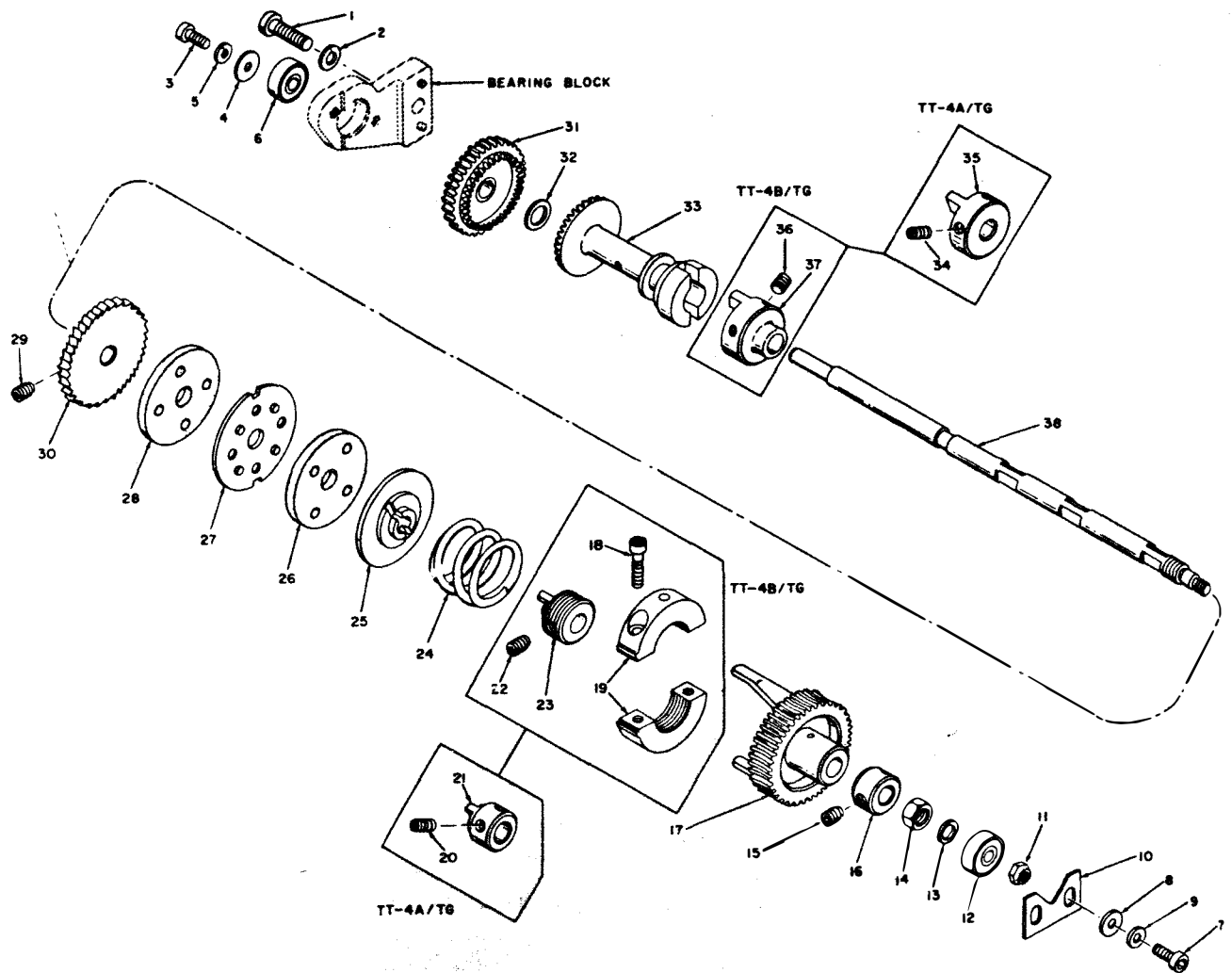

TM5815-206-35-77

- | | | |
|--|---|---|
| 1. Machine screw, 10017 | 15. Setscrew, 10209 | 26. Felt friction plate, 56765 |
| 2. Lockwasher, 10405 | 16. Shaft collar, 50209 | 27. Clutch driving disk, 51117 |
| 3. Machine screw, 10003 | 17. Carriage-feed gear and fork,
50116A*, 54930A* | 28. Felt friction plate, 56765 |
| 4. Flat washer, 10450 | 18. Machine screw, 10005 | 29. Setscrew, 10209 |
| 5. Lockwasher, 10403*, 10429* | 19. Friction-adjusting collar,
56832A (includes item 18) | 30. Carriage-feed ratchet, 50201A |
| 6. Ball bearing, 10755 | 20. Setscrew, 10209 | 31. Carriage-feed driving gear,
50884A |
| 7. Machine screw, 10003 | 21. Friction-adjusting collar, 50199 | 32. Flat washer, 50887 |
| 8. Flat washer, 10458*, 10459* | 22. Setscrew, 10208 | 33. Carriage-feed-clutch drum,
50331 |
| 9. Lockwasher, 10403*, 10429* | 23. Drive collar, 54928 | 34. Setscrew, 10209 |
| 10. Bearing retainer, 57716* | 24. Friction-clutch spring, 50859*,
54934b | 35. Drive collar, 50336 |
| 11. Self-locking hexagonal nut,
10500 | 25. Friction-clutch disk, 50198*,
54931* | 36. Setscrew, 10209 |
| 12. Ball bearing, 10755 | | 37. Drive collar, 59447 |
| 13. Flat washer, 51408 | | 38. Carriage-feed shaft, 50525 |
| 14. Adjusting nut, 51079 | | |

* Used on TT-4A/TG.

* Used on TT-4B/TG.

Figure 116. Carriage-feed shaft assembly, exploded view.

- (4) Mark the two teeth on the carriage-return driving gear that engage the last tooth on the carriage-return driven gear.
- (5) Move the carriage to a position that

permits a wrench to be inserted into the two machine screws (1) that hold the decelerating cam (2) to the carriage-return clutch assembly (12); remove the two machine screws and

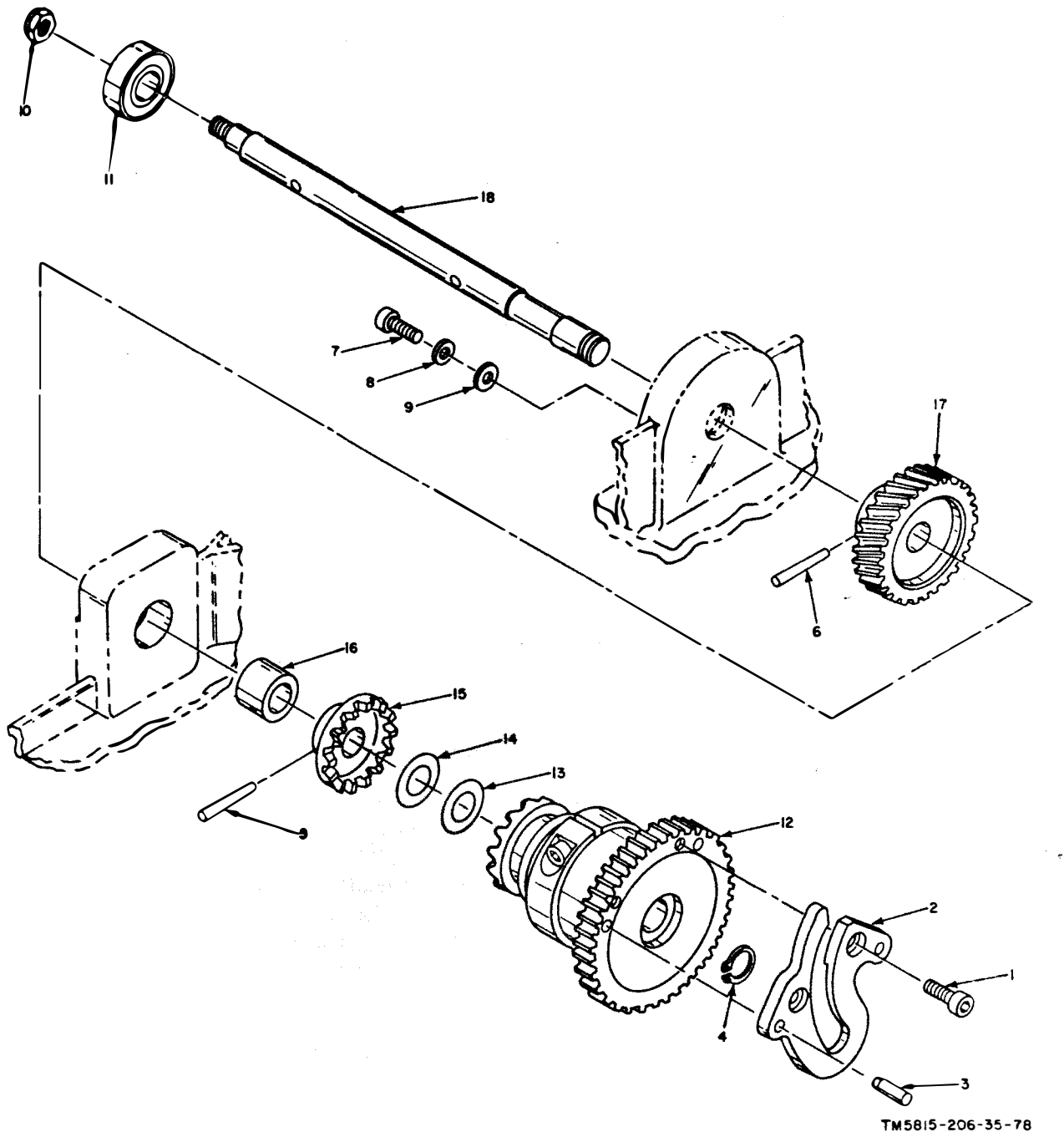

- | | | |
|----------------------------|---|--|
| 1. Machine screw, 10001 | 8. Lockwasher, 10403 | 13. Spacer, 52117 |
| 2. Decelerating cam, 50364 | 9. Flat washer, 10458 | 14. Spacer, 50552 |
| 3. Dowel pin, 10917 | 10. Self-locking hexagonal nut, 10500 | 15. Carriage-return-driving disk, 50211 |
| 4. Retainer ring, 10451 | 11. Ball bearing, 10759 | 16. Bearing, 10711 |
| 5. Taper pin, 10852 | 12. Carriage-return clutch assembly, 50212A | 17. Carriage-return-shaft driven gear, 50358 |
| 6. Taper pin, 10852 | | |
| 7. Machine screw, 10003 | | |

Figure 117. Carriage-return shaft assembly (TT-4A/TG), exploded view.

inserted into
(1) that hold
) to the car-
embly (12);
e s vs and

remove the decelerating cam. If necessary, remove the two dowel pins (3) from the carriage-return clutch assembly.

- (6) Support the carriage-return shaft with wooden blocks and drive the taper pins (5 and 6) from the carriage-return shaft.
- (7) Remove the retainer ring (4) that secures the carriage-return clutch assembly to the carriage-return shaft; remove the carriage-return clutch assembly.
- (8) Remove the two machine screws (7), lockwashers (8), and flat washers (9) that hold the ball bearing (11) in the rear casting.
- (9) Remove the self-locking hexagonal nut (10) from the carriage-return shaft (18) and remove ball bearing (11) from the rear casting.
- (10) Remove the spacers (13 and 14) and carriage-return driving disk (15) from the carriage-return shaft.
- (11) Remove the carriage-return shaft by passing it through the rear casting; remove the bearing (16) and the carriage-return-shaft driven gear (17) as they fall from the shaft.

b. Reassembly.

Note. If a new decelerating cam (2) is used, secure the new cam to the carriage-return clutch assembly (12) with two machine screws (1). Drill from the back of the clutch, through the holes in the clutch, to provide holes in the cam for the dowel pins (3).

- (1) Reassemble the carriage-return shaft assembly as indicated in figure 117; the sequence for assembling the parts is the reverse of the disassembly sequence. Be sure that the last tooth on the carriage-return driven gear is engaged with the teeth on the carriage-return driving gear that were marked during disassembly.
- (2) Replace the carriage-return operating mechanism (par. 111b).
- (3) Replace the keyboard-transmitter (par. 61b).
- (4) Replace the paper-shaft bracket and the paper chute (par. 58b).

119. Disassembly and Reassembly of Carriage-Return Shaft Assembly (TT-4B/TG)

(fig. 118)

a. Disassembly.

- (1) Remove the paper-shaft bracket and the paper chute (par. 58a).
- (2) Remove the keyboard-transmitter (par. 61a).
- (3) Remove the manual carriage-return link (par. 108a).
- (4) Remove the carriage-return operating mechanism (par. 111a).
- (5) Mark the teeth on the carriage-return driving gear that engage the last tooth on the carriage-return driven gear.
- (6) Remove the two machine screws (1), lockwashers (2), and flat washers (3) that secure the bearing retainer (4); remove the bearing retainer.
- (7) Remove the two machine screws (5) and lockwashers (6) that hold the rear bearing cap to the frame; remove the rear bearing cap.
- (8) Remove the two machine screws (7) and lockwashers (8) that hold the front bearing cap to the frame; remove the front bearing cap.
- (9) Remove the self-locking hexagonal nut (9) and ball bearing (10) from the carriage-return shaft.
- (10) Lift the front of the carriage-return shaft (23) slightly and slide the bearing (20) toward the front of the shaft to clear the bearing seat in the teletypewriter frame.
- (11) Tilt the carriage-return shaft (23) far enough forward to clear the carriage-return clutch lever, and pivot the lever so that it is parallel with the carriage-return shaft. Pull the carriage-return shaft upward and forward to remove it from the teletypewriter.
- (12) Remove the retainer ring (11) and remove the assembled carriage-return clutch assembly (15) and decelerating cam (13).
- (13) Remove the two machine screws (12) that hold the decelerating cam (13) to

the carriage-return clutch assembly (15); remove the cam from the clutch. If necessary, remove the two dowel pins (14) from the carriage-return clutch assembly.

- (14) Remove the spacers (16 and 17) from the carriage-return shaft.
- (15) Tap the taper pin (18) from the carriage-return driving disk (19), and remove the driving disk and the bearing (20) from the carriage-return shaft.
- (16) Tap the taper pin (21) from the carriage-return-shaft driven gear (22) and remove the gear from the carriage-return shaft (23).

b. Reassembly.

Note. If a new decelerating cam (13) is used, secure the new cam to the carriage-return clutch assembly (15) with two machine screws (12). Drill from the back of the clutch, through the holes in the clutch, to provide holes in the cam for the dowel pins (14).

- (1) Reassemble the carriage-return shaft assembly as indicated in figure 118; the sequence for assembling the parts is the reverse of the disassembly sequence. Be sure the last tooth on the carriage-return driven gear is engaged with the teeth on the carriage-return driving gear that were marked during disassembly.
- (2) Replace the carriage-return operating mechanism (par. 111b).
- (3) Replace the manual carriage-return link (par. 108b).
- (4) Replace the keyboard-transmitter (par. 61b).
- (5) Replace the paper-shaft bracket and the paper chute (par. 58b).

120. Disassembly and Reassembly of Carriage-Return Clutch Assembly (fig. 119)

a. Disassembly.

- (1) On the TT-4A/TG, remove the carriage-return clutch assembly (12, fig. 117) from the carriage-return shaft (par. 118a).
- (2) On the TT-4B/TG, remove the carriage-return clutch assembly (15, fig. 118) from the carriage-return shaft (par. 119c).
- (3) Remove the retainer ring (1, fig. 119)

and flat washer (2) that hold the carriage-return-clutch drum (3) on the end of the clutch sleeve (17).

- (4) Carefully remove the carriage-return-clutch drum (3) from the clutch sleeve (17); catch the nine positioning balls (4) as the drum is removed.
- (5) On the TT-4A/TG, remove the machine screw (5) that holds the adjusting collar (6) to the clutch sleeve (17); remove the collar, rubber spring (7), ball retainer ring (8), and friction disk (9).
- (6) On the TT-4B/TG, remove the machine screw (10) that holds the adjusting collar (11) to the clutch sleeve (17); remove the adjusting collar, friction-clutch spring (12), ball retainer ring (8), and friction disk (13).
- (7) Remove the felt friction plate (14), carriage-return driving gear (15), and felt friction plate (16) from the clutch sleeve (17).

b. Reassembly.

Note. The carriage-return-clutch drum (3) and the clutch sleeve (17) are matched parts. If replacement is necessary, replace both as a matched set.

- (1) Reassemble the carriage-return clutch assembly as indicated in figure 119; the sequence for assembling the parts is the reverse of the disassembly sequence.
- (2) Install the carriage-return clutch assembly on the carriage-return shaft assembly (par. 118b (TT-4A/TG); par. 119b (TT-4B/TG)).
- (3) Adjust the carriage-return clutch assembly (par. 220).

121. Disassembly and Reassembly of Keyboard-Transmitter Drive Shaft Assembly (fig. 120)

a. Disassembly.

- (1) Remove the keyboard-transmitter (par. 61a).
- (2) Remove one paper-shaft bracket and the paper chute (par. 58a).
- (3) On the TT-4B/TG, remove the two machine screws (1) and lock washers (2) that hold the bearing cap to the frame; remove the bearing cap.

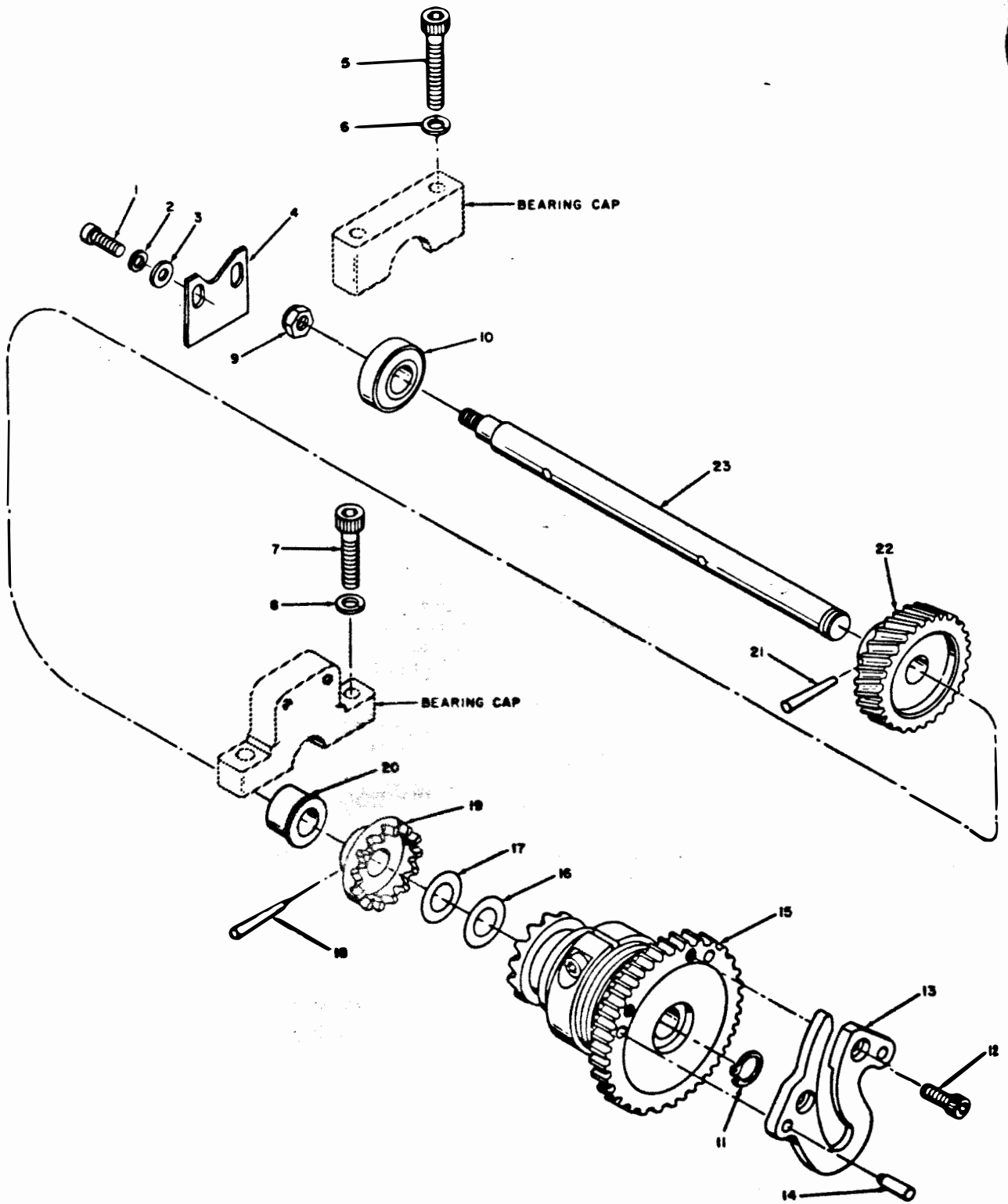

TT-5815-206-39-77

- 1. Machine screw, 10003
- 2. Lockwasher, 10429
- 3. Flat washer, 10459
- 4. Bearing retainer, 57716

- 5. Machine screw, 10012
- 6. Lockwasher, 10430
- 7. Machine screw, 10011
- 8. Lockwasher, 10430

- 9. Self-locking hexagonal nut, 10500
- 10. Ball bearing, 10759
- 11. Retainer ring, 10451

Figure 118. Carriage-return shaft assembly (TT-4B/TG), exploded view.

12. Machine screw, 10001
13. Decelerating cam, 50364
14. Dowel pin, 10917
15. Carriage-return clutch assembly, 51642A

16. Spacer, 52117
17. Spacer, 50552
18. Taper pin, 10852
19. Carriage-return driving disk, 50211

20. Bearing, 10711
21. Taper pin, 10852
22. Carriage-return-shaft driven gear, 55164
23. Carriage-return shaft, 55171

Figure 118—Continued

- (4) On the TT-4B/TG, remove the two self-locking hexagonal nuts (3), blocking plate (27), plain hexagonal nut (28), and lockwashers (4) that hold the mounting bracket (26) to the frame.
- (5) Remove the two machine screws (16), flat washers (17), and lockwashers (18). On the TT-4B/TG, remove the bearing retainer (19) from the frame.
- (6) Remove the self-locking hexagonal nut (20) from the end of the transmitter drive shaft (25). On the TT-4B/TG, remove the spacer (21). Remove the ball bearing (22); remove the transmitter drive shaft assembly.
- (7) Remove the two setscrews (5) that hold the clutch disk (6) to the transmitter drive shaft (25); remove the clutch disk (6), felt friction plate (7), clutch disk (8), felt friction plate (9), clutch disk (10), and friction-clutch spring (11).
- (8) On the TT-4B/TG, remove the machine screw (12) that locks the friction-adjusting collar (13) to the drive collar (15); remove the friction-adjusting collar.
- (9) On the TT-4B/TG, remove the setscrews (14) that lock the drive collar (15) to the transmitter drive shaft; remove the drive collar and mounting bracket (26).
- (10) On the TT-4A/TG, remove the two setscrews (30) that hold the friction-adjusting collar (31) on the transmitter drive shaft (25); remove the collar.

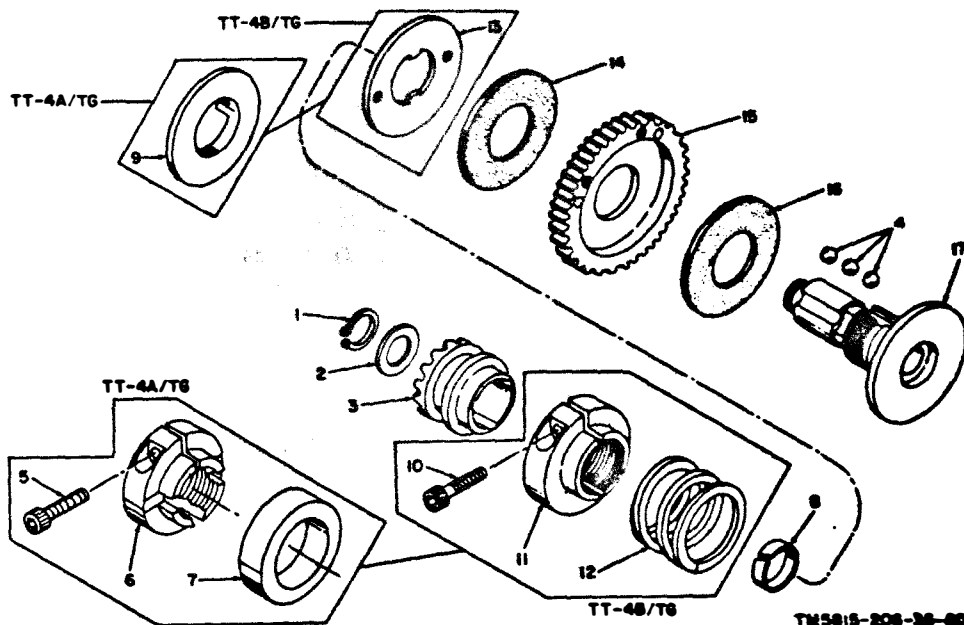

1. Retainer ring, 10453
2. Flat washer, 50306
3. Carriage-return-clutch drum, 50186
4. Positioning ball, 10908
5. Machine screw 10010
6. Adjusting collar, 50176

7. Rubber spring, 50259 (super-seeded by item 12)
8. Ball retainer ring, 51651
9. Friction disk, 50258
10. Machine screw, 10010
11. Adjusting collar, 51697
12. Friction-clutch spring, 55042

13. Friction disk, 51678
14. Felt friction plate, 50260
15. Carriage-return driving gear, 50257
16. Felt friction plate, 50260
17. Clutch sleeve, 51641A

Figure 118. Carriage-return clutch assembly, exploded view.

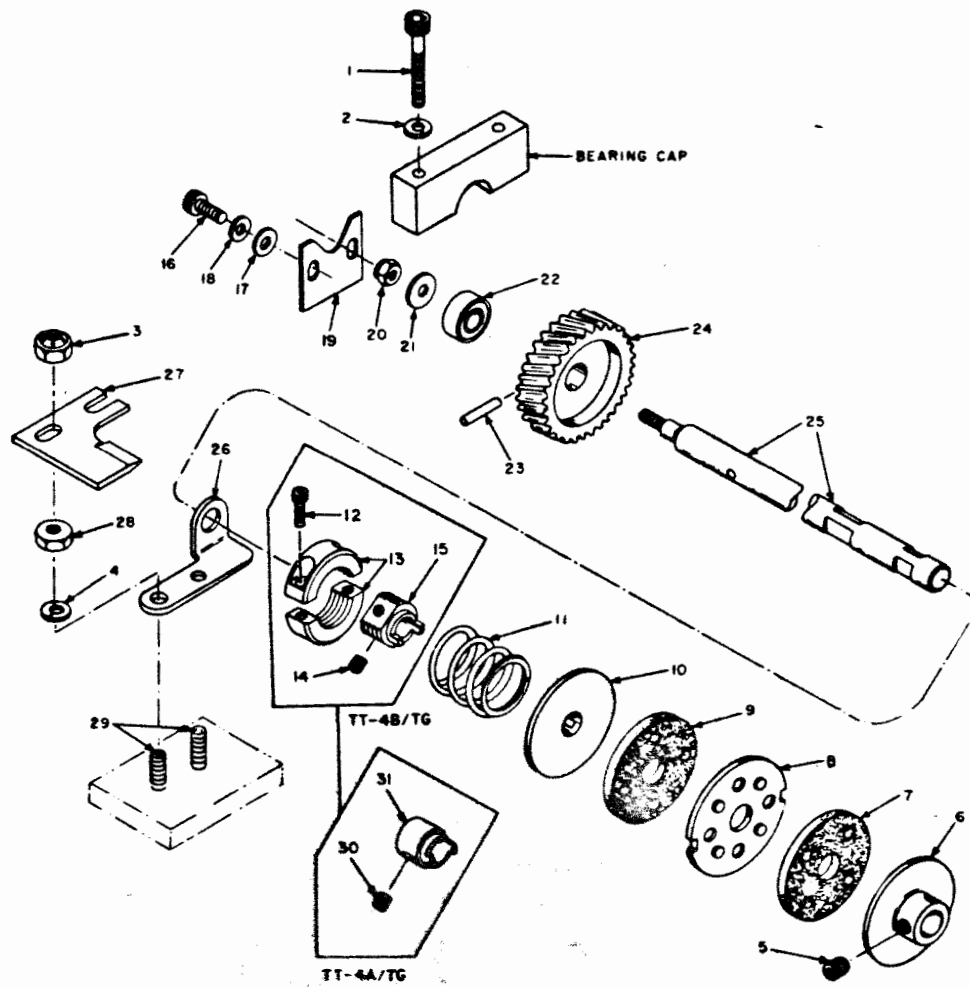

- | | | |
|---|--|--|
| 1. Machine screw, 10012 ^a | 12. Machine screw, 10005 | 22. Ball bearing, 10755 |
| 2. Lockwasher, 10430 ^a | 13. Friction-adjusting collar, 56832A (includes item 12) | 23. Taper pin, 10854 |
| 3. Self-locking hexagonal nut, 10501 | 14. Setscrew, 10208 | 24. Transmitter-shaft driven gear, 55163 |
| 4. Lockwasher, 10430 ^a | 15. Drive collar, 54928 | 25. Transmitter drive shaft, 51554 ^a , 55172 ^b |
| 5. Setscrew, 10209 | 16. Machine screw, 10003 | 26. Mounting bracket, 55787 ^a |
| 6. Clutch disk, 50200 | 17. Flat washer, 10458 ^a , 10459 ^b | 27. Blocking plate, 56707 ^a |
| 7. Felt friction plate, 56765 | 18. Lockwasher, 10403 ^a , 10429 ^b | 28. Plain hexagonal nut, 10505 ^a |
| 8. Clutch disk, 51117 | 19. Bearing retainer, 57716 ^a | 29. Mounting stud, 10237 ^a |
| 9. Felt friction plate, 56765 | 20. Self-locking hexagonal nut, 10500 | 30. Setscrew, 10209 |
| 10. Clutch disk, 50198 ^a , 54931 ^b | 21. Spacer, 50414 ^a | 31. Friction-adjusting collar, 50199 |
| 11. Friction-clutch spring, 50914 ^a , 54932 ^b | | |

^a Used on TT-4A/TG.

^b Used on TT-4B/TG.

Figure 120. Keyboard-transmitter drive shaft assembly, exploded view.

- (11) Tap the taper pin (23) from the transmitter-shaft driven gear (24); remove the transmitter-shaft driven gear from the transmitter drive shaft (25).
- (12) Remove the mounting studs (29) from the frame.

b. Reassembly.

- (1) Reassemble the keyboard-transmitter drive shaft assembly on the teletypewriter as indicated in figure 120; the sequence for assembling the parts is the reverse of the disassembly sequence.
- (2) Install the keyboard-transmitter (par. 61b).

- (3) Replace the paper-shaft bracket and the paper chute (par. 58b).
- (4) Adjust the keyboard-transmitter friction clutch (par. 145 or 146).

122. Removal and Replacement of Motor-Stop Assembly (TT-4A/TG)
(fig. 121)

a. Removal.

- (1) Remove the two self-locking hexagonal nuts (1) and lockwashers (2) that hold the motor-stop contact shield (3) to the mounting studs (7); remove the motor-stop contact shield and two lockwashers (4).
- (2) Disconnect the four cable leads from the motor-stop contact block (9); tag the leads.
- (3) Remove the two machine screws (5) and lockwashers (6) that hold the motor-stop bracket (30) to the frame; remove the motor-stop assembly.

b. Replacement.

- (1) Replace the motor-stop assembly as indicated in figure 121; the installation sequence is the reverse of the removal sequence.
- (2) Adjust the motor-stop assembly (par. 263).

123. Disassembly and Reassembly of Motor-Stop Assembly (TT-4A/TG)
(fig. 121)

a. Disassembly.

- (1) Remove the motor-stop assembly (par. 122a).
- (2) Remove the two mounting studs (7) that hold the motor-stop contact block (9) to the motor-stop bracket (30); remove the motor-stop contact block. If necessary, remove the two setscrews (8) from the motor-stop contact block.
- (3) Remove the relay armature spring (10) from the motor-stop armature (16) and from the spring post on the motor-stop bracket (30).
- (4) Remove the two retainer rings (11 and 12) and armature shaft (13) that hold the motor-stop armature (16) to the motor-stop bracket (30); remove the motor-stop armature.
- (5) Remove the two machine screws (14)

and plain hexagonal nuts (15) from the motor-stop armature (16).

- (6) Remove the contact-lever shaft (17) that holds the contact lever (23) to the motor-stop bracket (30); remove the contact lever.
- (7) Remove the machine screw (18) and lockwasher (19) that hold the contact lever lug (20) to the contact lever (23); remove the contact lever lug.
- (8) Remove the two eccentric sleeves (21 and 22) from the contact lever (23).
- (9) Remove the two machine screws (24), lockwashers (25), plain hexagonal nuts (26), and lockwashers (27) that hold the relay coil (29) to the motor-stop bracket (30). Unsolder the coil leads and remove the tubing (28), if necessary.

b. Reassembly.

- (1) Reassemble the motor-stop assembly as indicated in figure 121; the sequence for assembling the parts is the reverse of the disassembly sequence.
- (2) Replace the motor-stop assembly (par. 122b).
- (3) Adjust the motor-stop assembly (par. 264).

124. Removal and Replacement of Motor-Stop Assembly (TT-4B/TG)
(fig. 122)

a. Removal.

- (1) Remove the two machine screws (1) and lockwashers (2) that hold the motor-stop-switch cover (3) to the cover mounting studs (6); remove the motor-stop-switch cover.
- (2) Disconnect the cable leads; tag the leads to facilitate reassembly.
- (3) Remove the two machine screws (4) and lockwashers (5) that hold the motor-stop bracket (47) to the frame; remove the motor stop.

b. Replacement.

- (1) Replace the motor-stop assembly as indicated in figure 122; the sequence for assembling the parts is the reverse of the removal sequence.
- (2) Adjust the motor-stop assembly (par. 265).

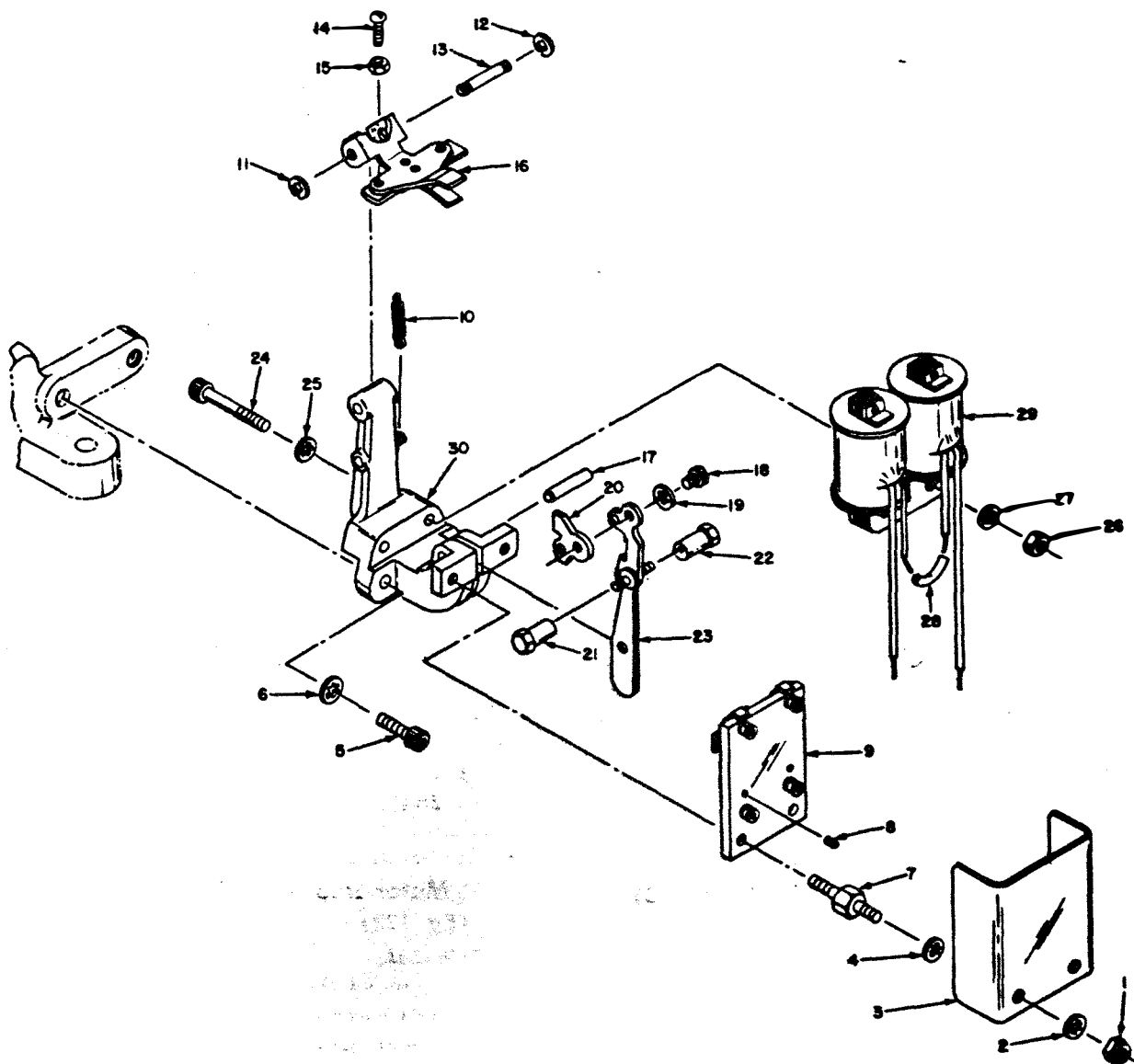

TM5615-206-35-82

- | | | |
|--|---|--|
| 1. Self-locking hexagonal nut, 10500 | 11. Retainer ring, 51099 | 21. Eccentric sleeve, 50957 |
| 2. Lockwasher, 10403 | 12. Retainer ring, 51099 | 22. Eccentric sleeve, 50957 |
| 3. Motor-stop contact shield, 50967 | 13. Armature shaft, 50963 | 23. Contact lever, 50955A (includes items 21 and 22) |
| 4. Lockwasher, 10403 | 14. Machine screw, 10350 | 24. Machine screw, 10012 |
| 5. Machine screw, 10010-01 | 15. Plain hexagonal nut, 10520 | 25. Lockwasher, 10404 |
| 6. Lockwasher, 10404 | 16. Motor-stop armature, 50952 (includes items 14 and 15) | 26. Plain hexagonal nut, 10505 |
| 7. Mounting stud, 50968 | 17. Contact-lever shaft, 50962 | 27. Lockwasher, 10404 |
| 8. Setscrew, 10203 | 18. Machine screw, 10002 | 28. Tubing, 20732A |
| 9. Motor-stop contact block E3, 50969A (includes item 8) | 19. Lockwasher, 10403 | 29. Relay coil, 50271A |
| 10. Relay armature spring, 50965 | 20. Contact lever lug, 50975 | 30. Motor-stop bracket, 51407A |

Figure 121. Motor-stop assembly (TT-4A/TG), exploded view.

125. Disassembly and Reassembly of Motor-Stop Assembly (TT-4B/TG) (fig. 122)

a. Disassembly.

- (1) Remove the motor stop assembly (par. 124a).
- (2) Remove the two cover mounting studs (6) that hold the switch bracket (19)

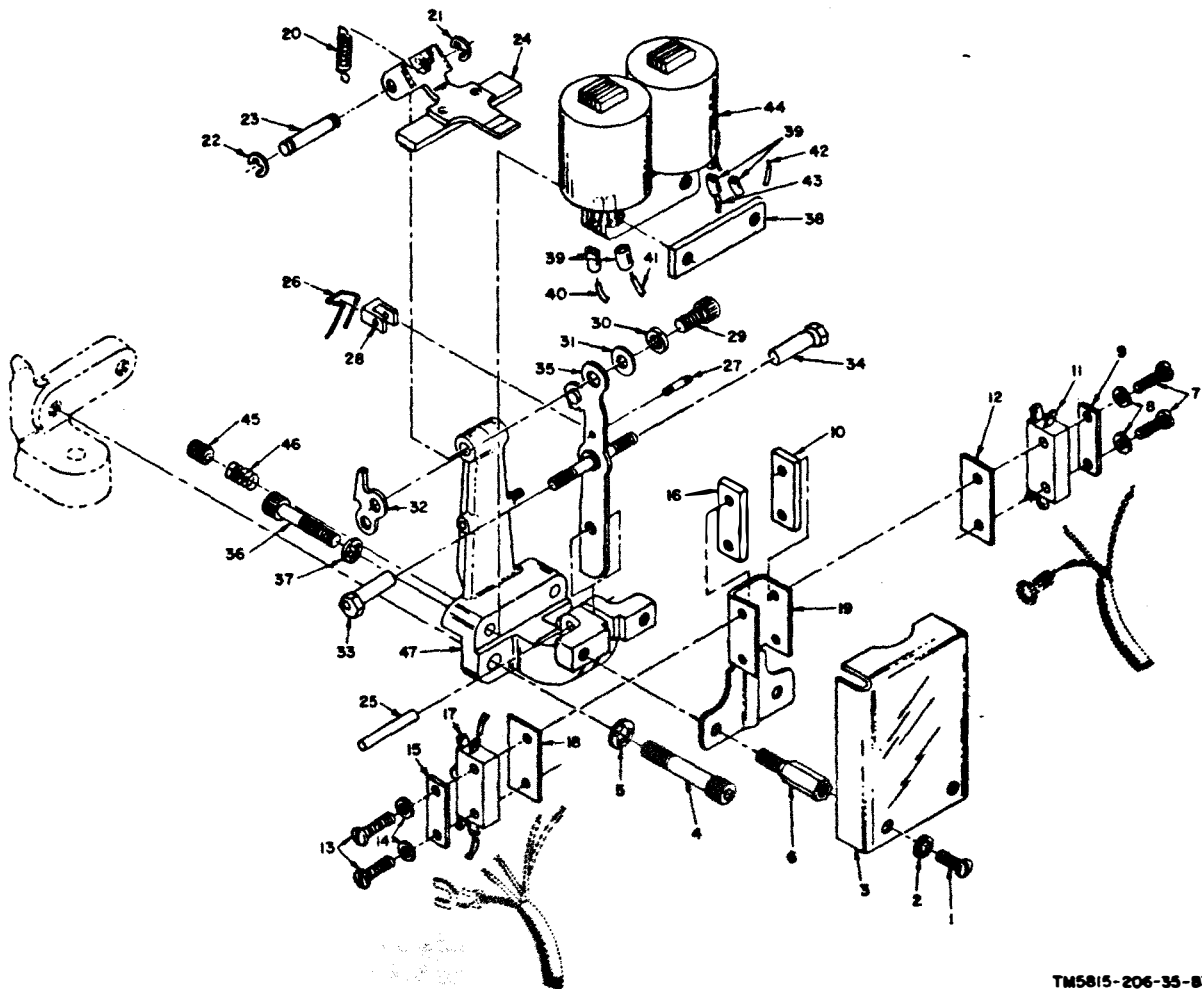

TM5815-206-35-83

- | | | |
|-----------------------------------|--------------------------------------|---|
| 1. Machine screw, 10393 | 17. Switch S5, 20144 | 33. Eccentric sleeve, 50957 |
| 2. Lockwasher, 10403 | 18. Switch insulator, 60617 | 34. Eccentric sleeve, 50957 |
| 3. Motor-stop-switch cover; 60618 | 19. Switch bracket, 60627 | 35. Contact lever, 60626A (includes items 28, 33, and 34) |
| 4. Machine screw, 10012 | 20. Relay armature spring, 50965 | 36. Machine screw, 10012 |
| 5. Lockwasher, 10404 | 21. Retainer ring, 10969 | 37. Lockwasher, 10404 |
| 6. Cover mounting stud, 60619 | 22. Retainer ring, 10969 | 38. Nut plate, 60613 |
| 7. Machine screw, 10139 | 23. Armature shaft, 60614 | 39. Tubing, 20754-00.50 |
| 8. Lockwasher, 10433 | 24. Relay armature, 60612A | 40. Wire, 22055-04.43 |
| 9. Switch plate, 60609 | 25. Contact-lever pivot shaft, 10978 | 41. Wire, 22000-02.03 |
| 10. Switch nut plate, 60298 | 26. Armature latch spring, 60625 | 42. Wire, 22055-03.43 |
| 11. Switch S6, 20144 | 27. Armature latch pin, 60624 | 43. Wire, 22000-02.03 |
| 12. Switch insulator, 60617 | 28. Armature latch, 60628 | 44. Relay coil, 60604A |
| 13. Machine screw, 10139 | 29. Machine screw, 10001 | 45. Setscrew, 10211 |
| 14. Lockwasher, 10433 | 30. Lockwasher, 10429 | 46. Contact-lever spring, 60607 |
| 15. Switch plate, 60609 | 31. Flat washer, 10458 | 47. Motor-stop bracket, 50951A |
| 16. Switch nut plate, 60298 | 32. Contact-lever lug, 50975 | |

Figure 122. Motor-stop assembly (TT-4B/TG), exploded view.

to the motor-stop bracket (47); remove the switch bracket.

- (3) Remove the two machine screws (7), lockwashers (8), switch plate (9), and switch nut plate (10) that hold the switch (11) to the switch

bracket (19); remove the switch and switch insulator (12).

- (4) Remove the two machine screws (13), lockwashers (14), switch plate (15), and switch nut plate (16) that hold the switch (17) to the switch

(19); remove the switch and switch insulator (18).

- (5) Remove the relay armature spring (20) from the relay armature (24) and from the spring post on the motor-stop bracket (47).
- (6) Remove the two retainer rings (21 and 22) and armature shaft (23) that hold the relay armature (24) to the motor-stop bracket (47); remove the relay armature.
- (7) Remove the set screw (45) that holds the switch lever spring (46) in the motor-stop bracket (47); remove the switch lever spring.
- (8) Remove the contact-lever pivot shaft (25) that holds the contact lever (35) on the motor-stop bracket (47); remove the contact lever.
- (9) Remove the armature latch spring (26) from the armature latch pin (27) and from the armature latch (28).
- (10) Remove the armature latch pin (27) that holds the armature latch (28) to the contact lever (35); remove the armature latch.
- (11) Remove the machine screw (29), lockwasher, (30), and flat washer (31) that hold the contact-lever lug (32) to the contact lever (35); remove the contact-lever lug.
- (12) Remove the two eccentric sleeves (33 and 34) from the contact lever (35).
- (13) Remove the two machine screws (36), lockwashers (37), and nut plate (38) that hold the relay coil (44) to the motor-stop bracket (47); remove the relay coil.
- (14) Remove the tubing (39) and wires (40 through 43), if necessary.

b. Reassembly.

- (1) Reassemble the motor-stop assembly as indicated in figure 122; the sequence for assembling the parts is the reverse of the disassembly sequence.
- (2) Replace the motor-stop assembly (par. 124b).
- (3) Adjust the motor-stop assembly (par. 266 through 269).

126. Disassembly and Reassembly of Paper Shaft, Paper-Shaft Brackets, and Paper Chute (fig. 123)

a. Disassembly.

- (1) Remove the paper shaft, both paper-shaft brackets, and the paper chute (par. 58a).
- (2) Remove the four rubber mounts (5, 6, 10, and 11) from the paper-shaft brackets (7 and 12).

b. Reassembly.

- (1) Reassemble the paper shaft, paper-shaft brackets, and paper chute as indicated in figure 123; the sequence for assembling the parts is the reverse of the disassembly sequence.
- (2) Replace the paper shaft, paper-shaft brackets, and paper chute (par. 58b).

127. Removal and Replacement of Motor Filter Box Assembly (fig. 124)

a. Removal.

- (1) Remove the teletypewriter from the mounting base (par. 59a).
- (2) Remove the four machine screws (1) and lockwashers (2) that hold the filter box cover (3) to the mounting studs (15); remove the filter box cover.
- (3) Disconnect the electrical leads of the motor power cable (9); from the terminal board TB2 (48); tag the leads to facilitate reassembly. Remove the strain relief (4) that holds the motor power cable to the filter box (62); remove the motor power cable.
- (4) Disconnect the electrical leads of the motor-stop cable (13) and the motor cable from terminal board TB3 (38); tag the leads to facilitate reassembly.
- (5) Remove the four mounting studs (15) and lockwashers (16) that hold the filter box (62) to the frame; remove the assembled filter box and electrical components, and remove the four lockwashers (114) that are installed between the filter box and frame.

b. Replacement.

- (1) Replace the motor filter box assembly as indicated in figure 124; the replace-

ly of Paper
ets and

both paper-
paper chute

mounts (5,
paper-shaft

shaft, paper-
chute as in
the sequence
the reverse

paper-shaft
(par. 58b).

of Motor

r from the

s (1)

t hold the

e mounting

r box cover.

leads of the

om the ter-

g the leads

Remove the

ds the mo-

r box (62);

le.

leads of the

the motor

TB3 (38);

reassemble.

studs (15)

t hold the

e; remove

d electrical

e four lock-

installed be-

ne.

x assembly

ne place-

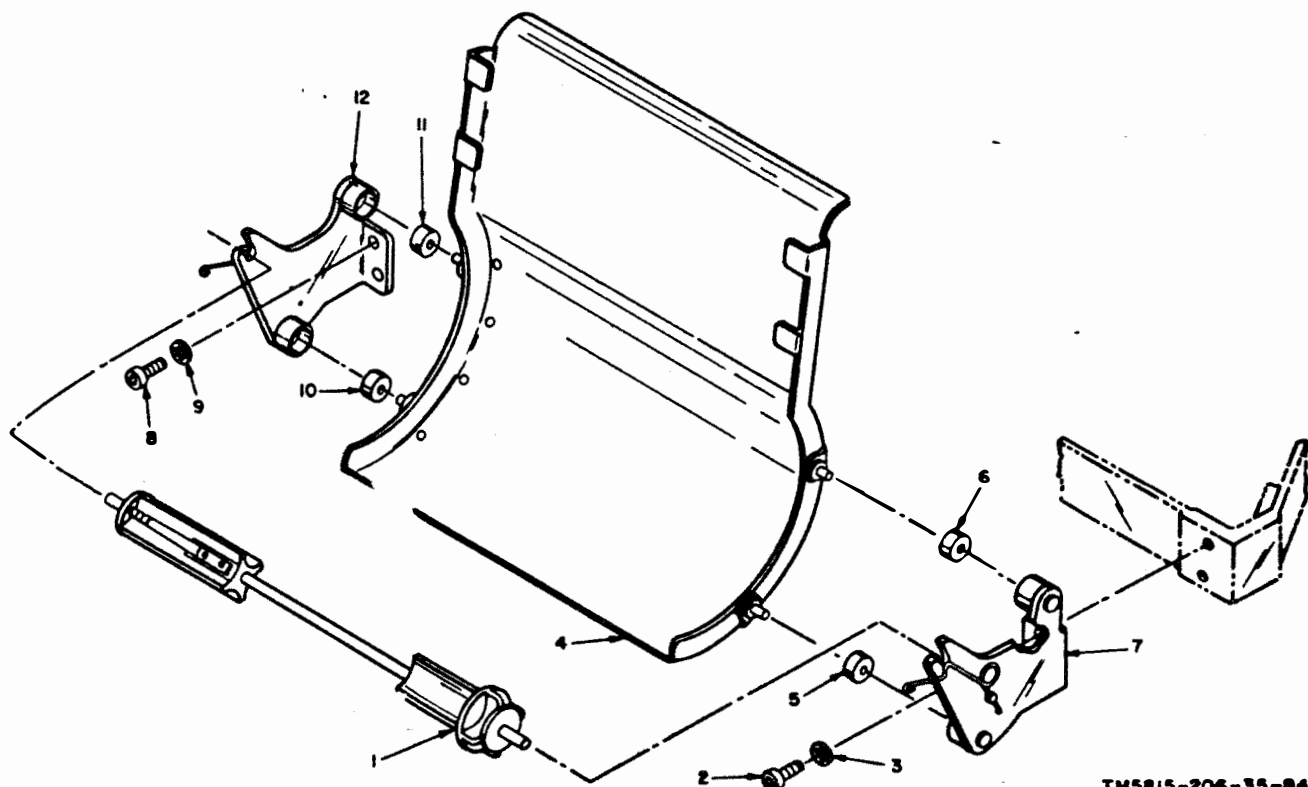

1. Paper shaft, 50605A
2. Machine screw, 10009
3. Lockwasher, 10404*, 10430*
4. Paper chute, 50261A
5. Rubber mount, 50252
6. Rubber mount, 50252
7. Paper-shaft bracket (lH), 5025A (includes items 5 and 6)
8. Machine screw, 10009
9. Lockwasher, 10404*, 10430*
10. Rubber mount, 50252
11. Rubber mount, 50252
12. Paper-shaft bracket (rH) 50255A (includes items 10 and 11)

* Used on TT-4A/TG.

* Used on TT-4B/TG.

Figure 123. Paper shaft, paper-shaft brackets, and paper chute, exploded view.

ment sequence is the reverse of the removal sequence.

- (2) Reconnect all electrical leads that have been disconnected and coat the electrical connections with fungi-resistant compound.
- (3) Replace the teletypewriter on the mounting base (par. 59b).

128. Disassembly and Reassembly of Motor Filter Box Assembly (fig. 124)

a. Disassembly.

- (1) Remove the motor filter box assembly (par. 127a).
- (2) Unsolder the leads that are connected to capacitor C22(30). Remove the two plain hexagonal nuts (17 and 24), lockwashers (18 and 25), terminal lugs (19 and 26), lockwashers (20 and 27), and terminal lug (23) that hold

capacitor C22 to the bracket on the filter box (62); remove capacitor C22, two machine screws (21 and 28), two lockwashers (22 and 29) and terminal lug (23).

- (3) Unsolder the leads that are connected to capacitor C15 (35). Remove the plain hexagonal nut (31), lockwasher (32), machine screw (33), and clamp (34) that hold capacitor C15 to the filter box (62); remove the capacitor.
- (4) Disconnect the leads from terminal board TB3(38). Remove the two machine screws (36) and lockwashers (37) that hold terminal board TB3 to the filter box (62); remove the terminal board.
- (5) Unsolder the leads from resistor R1 (44). Remove the plain hexagonal nut (39), lockwasher (40), resistor mounting stud (41), and lockwasher (42)

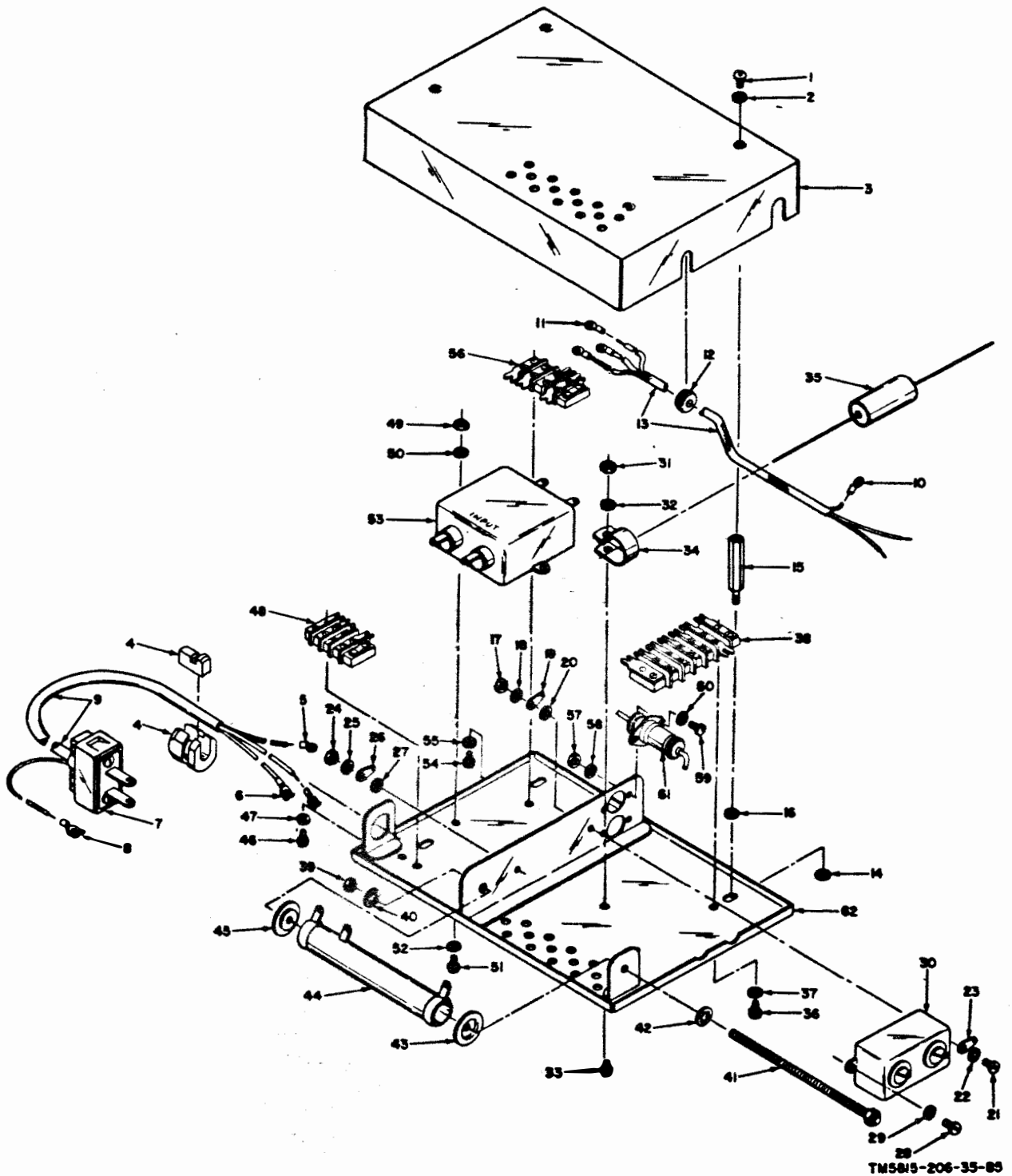

1. Machine screw, 10308
2. Lockwasher, 10403
3. Filter box cover, 51654
4. Strain relief, 20718
5. Terminal, 20706
6. Terminal, 20708
7. Plug P3, 20402
8. Terminal, 20721

9. Motor power cable 51653A
(includes items 6, 7, and 8)
10. Terminal, 20708
11. Terminal, 20706
12. Grommet, 20725
13. Motor-stop cable, 51165A
(includes items 10, 11, and 12)
14. Lockwasher, 10404

15. Mounting stud, 51058
16. Lockwasher, 10404
17. Plain hexagonal nut, 10511
18. Lockwasher, 10403
19. Terminal lug, 20735
20. Lockwasher, 10403
21. Machine screw, 10308
22. Lockwasher, 10403

Figure 124. Motor filter box assembly, exploded view.

23. Terminal lug, 20735
24. Plain hexagonal nut, 10511
25. Lockwasher, 10403
26. Terminal lug, 20735
27. Lockwasher, 10403
28. Machine screw, 10308
29. Lockwasher, 10403
30. Capacitor C22, 20200
31. Plain hexagonal nut, 10511
32. Lockwasher, 10403
33. Machine screw, 10301
34. Clamp, 20774
35. Capacitor C15, 20212
36. Machine screw, 10301

37. Lockwasher, 10402
38. Terminal board TB3, 20360
39. Plain hexagonal nut, 10516
40. Lockwasher, 10404
41. Resistor mounting stud, 56220A
42. Lockwasher, 10404
43. Centering washer, 10456
44. Resistor R1, 51628
45. Centering washer, 10456
46. Machine screw, 10301
47. Lockwasher, 10402
48. Terminal board TB2, 20359
49. Plain hexagonal nut, 10511

50. Lockwasher, 10403
51. Machine screw, 10301
52. Lockwasher, 10403
53. Filter Z1 (TT-4ATG); FL1 (TT-4B/TG), 20210
54. Machine screw, 10301
55. Lockwasher, 10402
56. Terminal board TB1, 20358
57. Plain hexagonal nut, 10511
58. Lockwasher, 10403
59. Machine screw, 10301
60. Lockwasher, 10403
61. Capacitor C18 and C19, 20208
62. Filter box, 51647A

Figure 124—Continued

that hold resistor R1 to the brackets on the filter box (62); remove the centering washer (43), resistor, and centering washer (45).

- (6) Disconnect all leads from terminal board TB2 (48). Remove the two machine screws (46) and lockwashers (47) that hold terminal board TB2 to the filter box (62); remove the terminal board.
- (7) Unsolder the leads from filter Z1 or FL1 (53). Remove the two plain hexagonal nuts (49), lockwashers (50), machine screws (51), and lockwashers (52) that hold the filter to the filter box (62); remove the filter.
- (8) Disconnect the leads from terminal board TB1 (56). Remove the two machine screws (54) and lockwashers (55) that hold the terminal board to the filter box; remove the terminal board.
- (9) Remove the four plain hexagonal nuts (57), lockwashers (58), machine screws (59), and lockwashers (60) that hold capacitors C18 and C19 (61) to the filter box (62); remove the capacitors.

b. Reassembly. Reassemble the motor filter box assembly by reversing the procedures described in *a*(2) through (9) above. Replace the motor filter box assembly (par. 127*b*).

Note. Rotate resistor R1 (44) to obtain a 1/4-inch gap between the resistor terminal and the machine screw (28) that secure the capacitor (30).

129. Disassembly and Reassembly of Line Terminal Board (fig. 125)

a. Disassembly.

- (1) Remove the line terminal board (par. 64*a*).
- (2) Remove the plain hexagonal nuts (9) that hold the jumper wire (10) to two of the five binding posts (19); remove the jumper wire and the two lockwashers (11).
- (3) Remove the two plain hexagonal nuts (12), flat washers (13), and insulating washers (14) that hold the two shorting bars (15) to the terminal board (20); remove the two shorting bars.
- (4) Remove the five plain hexagonal nuts

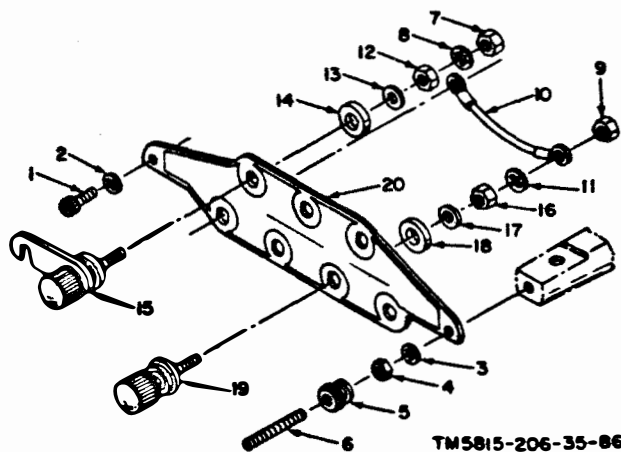

TM5815-206-35-86

1. Machine screw, 10024
2. Lockwasher, 10405
3. Lockwasher, 10405
4. Plain hexagonal nut, 10509
5. Knurled nut, 10518
6. Setscrew, 10214
7. Plain hexagonal nut, 10515
8. Lockwasher, 10404
9. Plain hexagonal nut, 10515
10. Jumper wire, 51163A
11. Lockwasher, 10404
12. Plain hexagonal nut, 10515
13. Flat washer, 10463
14. Insulating washer, 50909
15. Shorting bar, 56197A
16. Plain hexagonal nut, 10515
17. Flat washer, 10463
18. Insulating washer, 50909
19. Binding post, 20877
20. Terminal board, 50602

Figure 125. Line terminal board, exploded view.

(16), flat washers (17), and insulating washers (18) that hold the five binding posts (19) to the terminal board (20); remove the binding posts.

b. Reassembly.

- (1) Reassemble the line terminal board as indicated in figure 125; the sequence for assembling the parts is the reverse of the disassembly sequence.
- (2) Replace the line terminal board (par. 64b).

130. Disassembly and Reassembly of Teletypewriter Frame Assembly (fig. 126)

a. Disassembly.

- (1) Remove the dust cover (par. 57a).
- (2) Remove the paper shaft, paper-shaft bracket, and paper chute (par. 58a).
- (3) Remove the assembled teletypewriter from the mounting base (par. 59a).
- (4) Remove the teletypewriter motor (par. 60c).
- (5) Remove the keyboard-transmitter (par. 61a).
- (6) Remove the platen assembly (par. 62a).
- (7) Remove the two machine screws (15) and lockwashers (16) that hold the platen bracket (20) to the frame assembly. Remove the bumper (17), machine screw (18), and plain hexagonal nut (19) from the platen bracket (20).
- (8) Loosen the plain hexagonal nut (21) and remove assembled items (21 through 25) from the frame assembly. Remove the plain hexagonal nut (21), platen lock (22), lockwasher (23), and wing nut (24) from the setscrew (25).
- (9) Remove the carriage assembly (par. 63a).
- (10) Remove the line terminal board (par. 64a).
- (11) Remove the instrument panel (par. 65a).
- (12) Remove the selector-magnet assembly (par. 86a).
- (13) Remove the rangefinder (par. 87a (TT-4A/TG) or 88a (TT-4B/TG)).
- (14) Remove the selector levers and Y-levers (par. 89a (TT-4A/TG) or 90a (TT-4B/TG)).
- (15) Remove the transfer-lever shaft assembly (par. 91a).
- (16) Remove the print-bail-blade shaft assembly (par. 92a).
- (17) Remove the signal bell assembly (par. 93a).
- (18) Remove the function-selecting mechanism (par. 94a).
- (19) Remove the line-feed and platen-shift mechanisms (par. 95a (TT-4A/TG) or 96a (TT-4B/TG)).
- (20) Remove the square-shaft assembly (par. 97a).
- (21) Remove the function-shaft assembly (par. 98a).
- (22) Remove the selector camshaft assembly (par. 100a).
- (23) Remove the main shaft assembly (par. 101a (TT-4A/TG) or 102a (TT-4B/TB)).
- (24) Remove the code-ring cage (par. 104a).
- (25) Remove the function sensing lever group (par. 107a).
- (26) Remove the manual carriage-return mechanism (par. 108a).
- (27) Remove the carriage-feed mechanism (par. 109a (TT-4A/TG) or 110a (TT-4B/TG)).
- (28) Remove the carriage-return operating mechanism (par. 111a).
- (29) Remove the carriage-rack drive-shaft assembly (par. 114a).
- (30) Remove the margin-bell assembly (par. 115a).
- (31) Remove the carriage-feed shaft assembly (par. 116a (TT-4A/TG) or 117a (TT-4B/TG)).
- (32) Remove the carriage-return shaft assembly (par. 118a (TT-4A/TG) or 119a (TT-4B/TG)).
- (33) Remove the keyboard-transmitter drive shaft assembly (par. 121a).
- (34) Remove the motor-stop assembly (par. 122a (TT-4A/TG) or 124a (TT-4B/TG)).
- (35) Remove the motor filter box assembly (par. 127a).
- (36) On the TT-4A/TG, remove the two

machine screws (30 and 31) and two plain hexagonal nuts (29 and 32) from the frame assembly.

- (37) On the TT-4B/TG, remove the machine screw (31) and plain hexagonal nut (32) from the frame assembly.
- (38) On the TT-4B/TG, remove the self-locking hexagonal nut (45) that holds the eccentric post (46) to the eccentric post bracket (49); remove the eccentric post.
- (39) On the TT-4B/TG, remove the two machine screws (47) and lockwashers (48) that hold the eccentric post bracket (49) to the plate; remove the eccentric post bracket.
- (40) Remove the machine screws (33, 35, 37, 39, 41, and 43) and lockwashers (34, 36, 38, 40, 42, and 44) that hold the frame assembly together; disassemble the frame assembly (50) if necessary.

Note. Do not disassemble the frame assembly unless a portion of it has been damaged and must be replaced.

b. Reassembly. Reassemble the teletypewriter frame assembly as indicated in figure 126; the sequence for assembling the parts is the reverse of the disassembly sequence.

131. Disassembly and Reassembly of Dust Cover (fig. 127)

a. Disassembly.

- (1) Remove the dust cover (par. 57a).
- (2) Remove the thumb nut (1), plain hexagonal nut (2), lockwasher (3), and machine screw (4) that hold the ground loop of the copy light cable.
- (3) Remove the thumb nut (5), plain hexagonal nut (6), lockwasher (7), machine screw (8), and lockwasher (9) from the dust cover (46).
- (4) Remove the holder slide spring (10) from the copy holder (14) and from the holder slide (15).
- (5) Remove the machine screw (11) and slide the assembled holder slide from the dust cover (46).
- (6) Remove the cotter pin (12) and pin (13) that hold the copy holder (14) to the holder slide (15); remove the copy holder.

- (7) Remove the two plain hexagonal nuts (16 and 20), four lockwashers (17, 18, 21, and 23), and two machine screws (19 and 24) that hold the grounding bond (22) to the dust cover door (27) and to the dust cover (46).
- (8) Remove the three machine screws (25) and nuts (26) that hold the dust cover door (27) to the dust cover (46); remove the dust cover door.
- (9) Remove the four machine screws (28) and nuts (29) that hold the assembled window frame (35) to the dust cover (46); remove the assembled window frame.
- (10) Remove the four machine screws (30) that hold the window channel (31) to the window frame (35); remove the window channel and slide the window glass (32) from the window frame.
- (11) Remove the four machine screws (33) that hold the window channel (34) to the window frame (35); remove the window channel.
- (12) Remove the two lamps (36 and 37) from their sockets in the dust cover (46).
- (13) Remove the two plain hexagonal nuts (38) that hold the electrical leads of the copy light cable to the two copy light screws (44); remove the electrical leads and the four flat washers (39 and 40).
- (14) Remove the two assembled copy light screws (44) from their seat in the dust cover. Remove the two bushings (41), flat washers (42), and plain hexagonal nuts (43) from the copy light screws (44).
- (15) Remove the grommet (45) from the dust cover (46).

b. Reassembly.

- (1) Reassemble the dust cover as indicated in figure 127; the sequence for assembling the parts is the reverse of the disassembly sequence.
- (2) Adjust the copy light screws (44) as described in paragraph 274.
- (3) Replace the dust cover (par. 57b).

Figure 126. Typewriter frame assembly, exploded view.

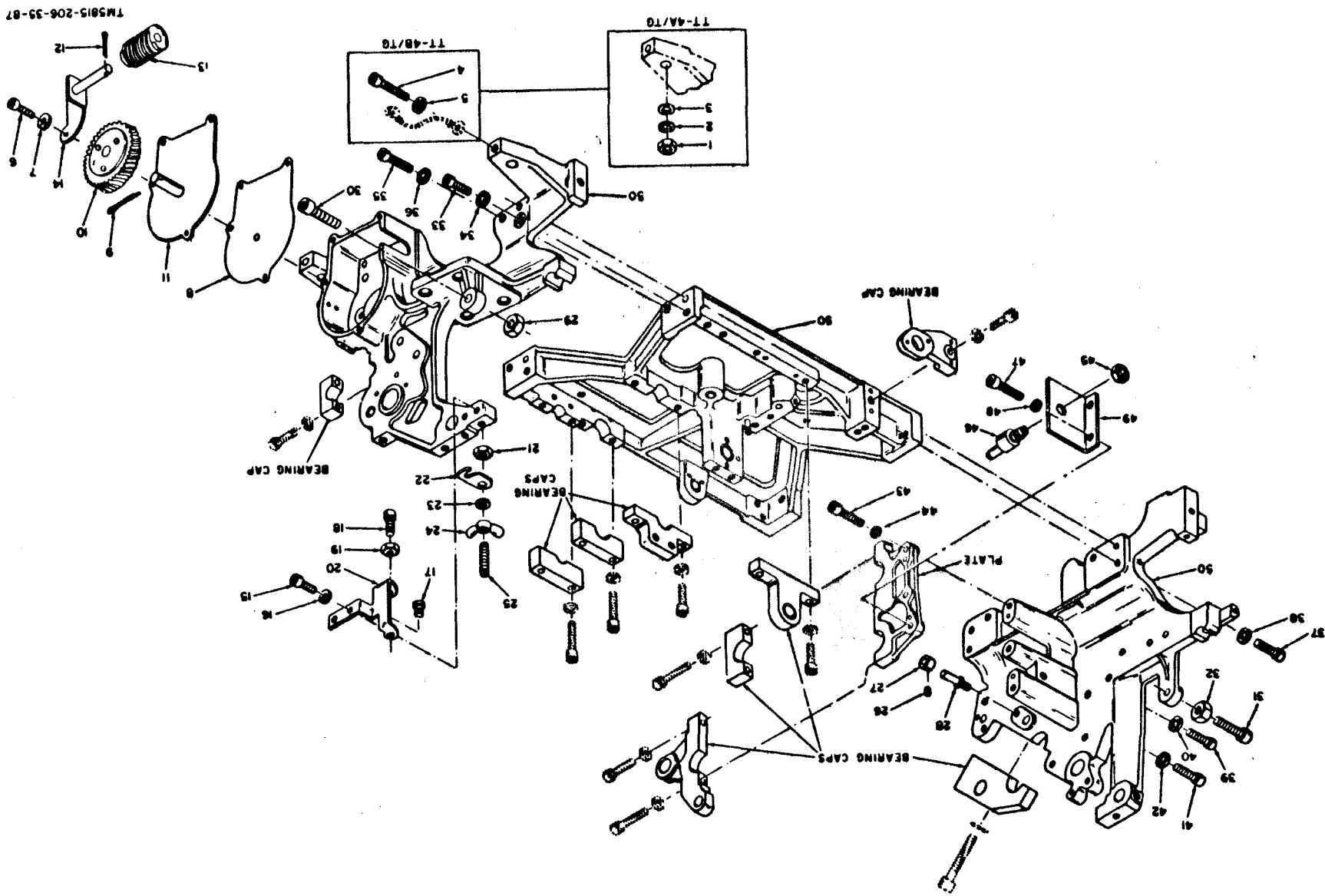

TM5015-206-33-87

- | | | |
|---|---|--|
| 1. Plain hexagonal nut, 10502 | 21. Plain hexagonal nut, 10509 | 38. Lockwasher, 10405 |
| 2. Lockwasher, 10400 | 22. Platen lock, 50598 | 39. Machine screw, 10018-01*, 10017 ^b |
| 3. Flat washer, 50272 | 23. Lockwasher, 10431 | 40. Lockwasher, 10405 |
| 4. Machine screw, 10035-01 | 24. Wing nut, 10508 | 41. Machine screw, 10021*, 10017 ^b |
| 5. Lockwasher, 10405 | 25. Setscrew, 10212 | 42. Lockwasher, 10405 |
| 6. Machine screw, 10004 | 26. Setscrew, 10201 | 43. Machine screw, 10018 |
| 7. Lockwasher, 10429 | 27. Spacing collar, 51717 | 44. Lockwasher, 10405*, 10431* |
| 8. Gasket, 50725 | 28. Cam follower stop stud, 51719 | 45. Self-locking hexagonal nut, 10534* |
| 9. Cotter pin, 10805 | 29. Plain hexagonal nut, 10502* | 46. Eccentric post, 57894 ^b |
| 10. Main shaft gear, 50597A | 30. Machine screw, 10021* | 47. Machine screw, 10018* |
| 11. Gear cover, 50853A | 31. Machine screw, 10021 | 48. Lockwasher, 10431 ^b |
| 12. Cotter pin, 10805 | 32. Plain hexagonal nut, 10502 | 49. Eccentric post bracket, 57895 ^b |
| 13. Worm, 50596 | 33. Machine screw, 10024*, 10024-01 ^b | 50. Frame assembly, 51031A*, 61096A* (includes bearing caps, three main castings, plate, dowels, and spring posts) |
| 14. Worm bracket, 50858A | 34. Lockwasher, 10405 | |
| 15. Machine screw, 10076 | 35. Machine screw, 10018-01*, 10017-01 ^b | |
| 16. Lockwasher, 10430 | 36. Lockwasher, 10405 | |
| 17. Bumper, 20762 | 37. Machine screw, 10018-01*, 10017 ^b | |
| 18. Machine screw, 10009*, 11209 ^b | | |
| 19. Plain hexagonal nut, 10516 | | |
| 20. Platen bracket, 51464 | | |

Note. The four bearing caps on the base frame (center) and the smaller of the two bearing caps on the plate (center, left) are on the TT-4B/TG only.

* Used on TT-4A/TG.

^b Used on TT-4B/TG.

Figure 126—Continued

132. Disassembly and Reassembly of Teletypewriter Base Assembly (fig. 128)

a. Disassembly.

- (1) Remove the dust cover (par. 57a).
- (2) Remove the mounting base (par. 59a).
- (3) Remove the two self-locking hexagonal nuts (1), lockwashers (2), machine screws (3), and lockwashers (4) that hold the grounding straps (5) to the base (24); remove the grounding straps and the lockwashers (6).
- (4) Remove the four machine screws (7) and nuts (8) that hold the four grounding straps (9) to the base (24); remove the grounding straps and the lockwashers (10).
- (5) On the TT-4A/TG, remove the four machine screws (11), lockwashers (12), and self-locking hexagonal nuts (13) that hold each of the four shock mounts (14) to the base (24); remove the shock mounts.
- (6) On the TT-4B/TG, remove the four machine screws (15), lockwashers (16), and self-locking hexagonal nuts (13) that hold each of the four assembled shock mounts (items 17 through 21) to the base (24); remove the assembled shock mounts.
- (7) On the TT-4B/TG, remove the snub-

bing washer (17) and lockwasher (18) that hold the mounting stud (19) in the shock mount (21); remove the mounting stud (19) and flat washer (20) from the shock mount (21).

- (8) On the TT-4B/TG, remove the two self-locking hexagonal nuts (22) that hold the two eccentric posts (23) to the base (24); remove the eccentric posts.

b. Reassembly.

- (1) Reassemble the teletypewriter base assembly as indicated in figure 128; the sequence for assembling the parts is the reverse of the disassembly sequence.
- (2) Replace the mounting base (par. 59b).
- (3) Replace the dust cover (par. 57b).
- (4) Adjust the eccentric posts (23) as described in paragraph 275.

133. Disassembly and Reassembly of Immersionproof Cover (fig. 129)

a. Disassembly.

- (1) Remove the retaining nut (1) that holds the air-relief valve (3) to the immersionproof cover (5); remove the outer seal (2) and the air-relief valve.
- (2) Remove the gasket (4) from the im-

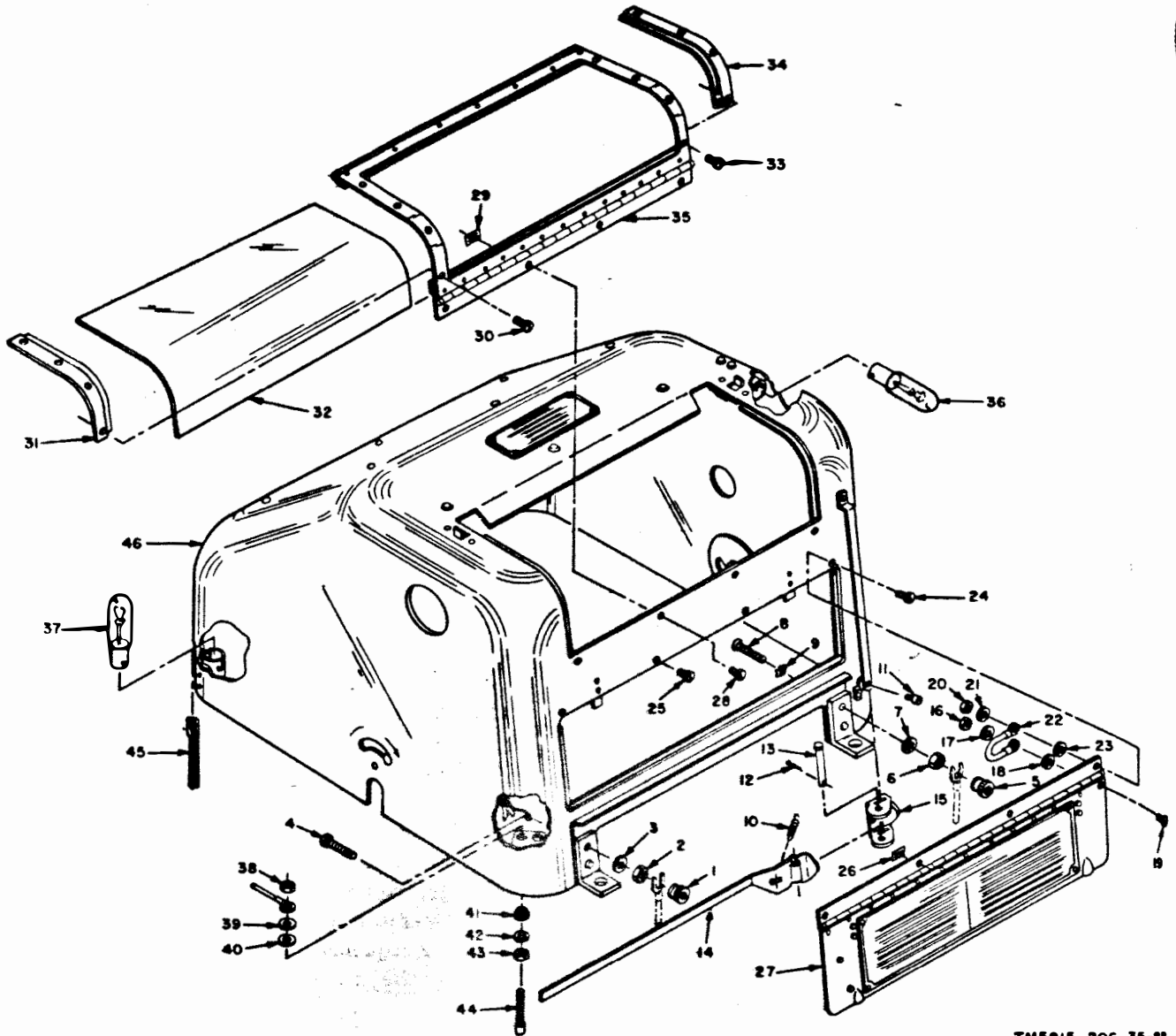

TM5815-206-35-88

- | | | |
|----------------------------------|--------------------------------|----------------------------------|
| 1. Thumb nut, 10518 | 17. Lockwasher, 10408 | 33. Machine screw, 10300 |
| 2. Plain hexagonal nut, 10509 | 18. Lockwasher, 10408 | 34. Window channel (rh), 50837 |
| 3. Lockwasher, 10405 | 19. Machine screw, 10335 | 35. Window frame, 50665A |
| 4. Machine screw, 10323*, 10364* | 20. Plain hexagonal nut, 10517 | (includes items 30 through 35) |
| 5. Thumb nut, 10518 | 21. Lockwasher, 10408 | 36. Lamp, 20701 |
| 6. Plain hexagonal nut, 10509 | 22. Grounding bond, 51191A | 37. Lamp, 20701 |
| 7. Lockwasher, 10405 | 23. Lockwasher, 10408 | 38. Plain hexagonal nut, 10515 |
| 8. Machine screw, 10323 | 24. Machine screw, 10335 | 39. Flat washer, 10463 |
| 9. Lockwasher, 10411 | 25. Machine screw, 10300 | 40. Flat washer, 51481 |
| 10. Holder slide spring, 54948 | 26. Nut, 10510 | 41. Bushing, 51106 |
| 11. Machine screw, 10002 | 27. Dust cover door, 51472A | 42. Flat washer, 10463 |
| 12. Cotter pin, 10801 | 28. Machine screw, 10300 | 43. Plain hexagonal nut, 10515 |
| 13. Pin, 50935 | 29. Nut, 10510 | 44. Copy light screw, 55022 |
| 14. Copy holder, 53192 | 30. Machine screw, 10300 | 45. Grommet, 51483 |
| 15. Holder slide, 50675 | 31. Window channel (lh), 50834 | 46. Dust cover, 51488A*, 60515A* |
| 16. Plain hexagonal nut, 10517 | 32. Window glass, 50833 | (includes items 1 through 45) |

* Used on TT-4A/TG.

* Used on TT-4B/TG.

Figure 127. Dust cover, exploded view.

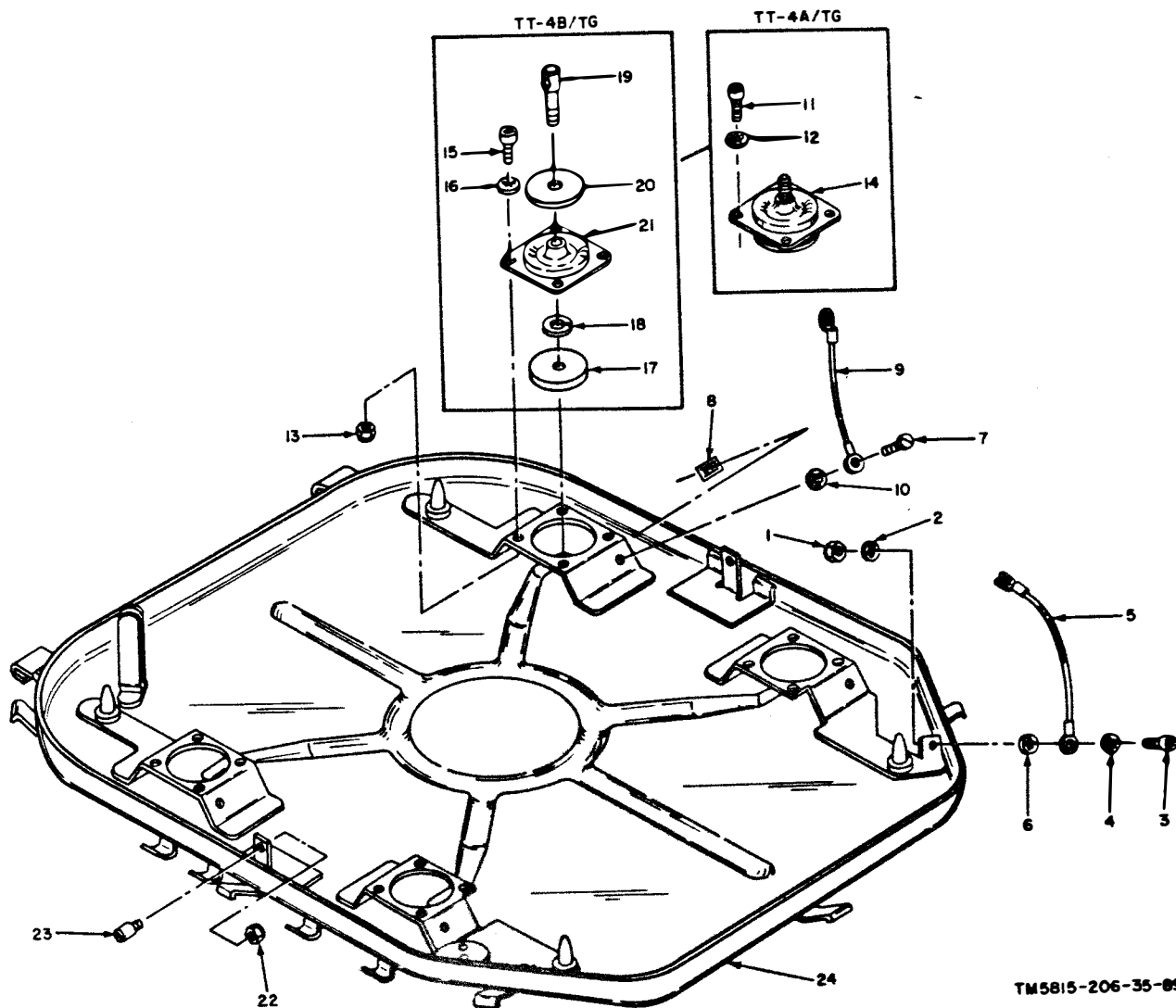

TM5815-206-35-89

- | | | |
|--------------------------------------|---------------------------------------|--|
| 1. Self-locking hexagonal nut, 10501 | 9. Grounding strap 50730A | 17. Snubbing washer, 59366 |
| 2. Lockwasher, 10404 | 10. Lockwasher, 10404 | 18. Lockwasher, 10427 |
| 3. Machine screw, 10008-01 | 11. Machine screw, 10008 | 19. Mounting stud, 59367 |
| 4. Lockwasher, 10404 | 12. Lockwasher, 10404 | 20. Flat washer, 50727 |
| 5. Grounding strap 51137A | 13. Self-locking hexagonal nut, 10501 | 21. Shock mount, 10911 |
| 6. Lockwasher, 10404 | 14. Shock mount, 50860A | 22. Self-locking hexagonal nut, 10500* |
| 7. Machine screw, 10351 | 15. Machine screw, 10008 | 23. Eccentric post, 59358* |
| 8. Nut, 10522 | 16. Lockwasher, 10404 | 24. Base, 51470A*, 57731A* (Includes items 1 through 23) |

* Used on TT-4A/TG.

* Used on TT-4B/TG.

Figure 128. Teletypewriter base assembly, exploded view.

mersionproof cover (5) if loose or defective.

b. *Reassembly.* Reassemble the immersion-proof cover as indicated in figure 129; the sequence for assembling the parts is the reverse of the disassembly sequence.

Note. Use gasket cement (Permatex No. 2, or equal), as an adhesive when replacing the gasket (4). Replace a defective air-relief valve (3) that does not have a cracking pressure of 3.5 pounds per square inch (psi) ± 20 percent, and a reseating pressure of 2.5 psi ± 10 percent.

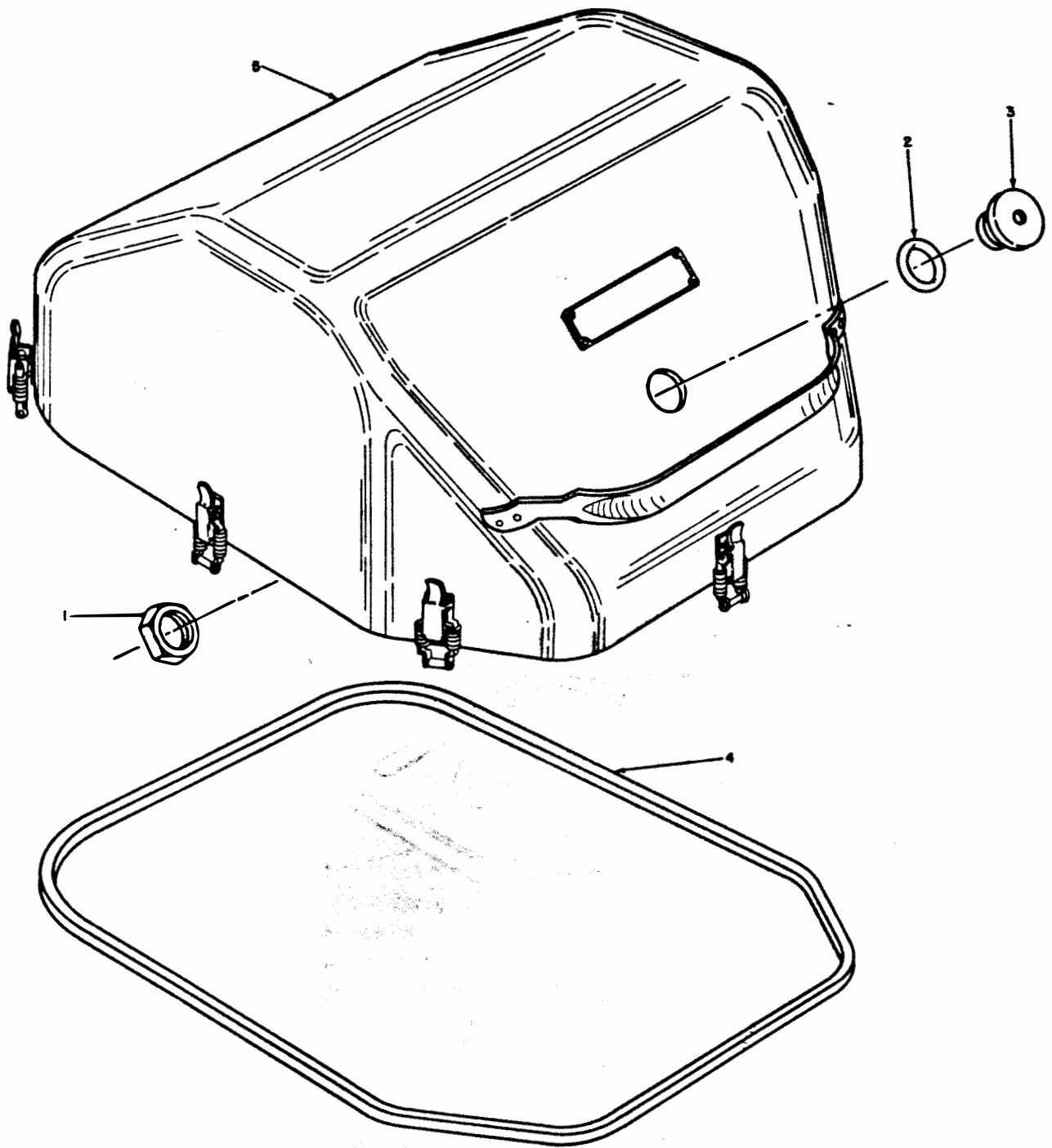

TM5815-206-35-90

- 1. Retaining nut, 51830
- 2. Outer seal, 10954

- 3. Air-relief valve, 51825
- 4. Gasket, 51096

- 5. Immersionproof cover, 57730A
(includes items 1 through 4)

Figure 129. Immersionproof cover, exploded view.

Section VII. TELETYPEWRITER ADJUSTMENT PROCEDURES

134. General

This section contains the requirements and adjustment procedures for Teletypewriters TT-4A/TG and TT-4B/TG. Adjustment procedures are arranged in the proper sequence for a complete readjustment of the teletypewriter. When making individual adjustments, check all related adjustments. When it is necessary to remove parts or subassemblies in order to make an adjustment, refer to the specific removal and replacement instructions in paragraphs 56 through 133. Adjustments applicable to only the TT-4A/TG or to only the TT-4B/TG are so identified; otherwise adjustments apply to both models.

135. Sequence Chart of Adjustments for TT-4A/TG and TT-4B/TG

Note. An asterisk in the TT-4A/TG or TT-4B/TG column of the following chart indicates that an adjustment procedure exists for that teletypewriter.

Par. No.	Name	TT-4A/TG	TT-4B/TG
136	Keylever-locking-bar adjustment.		(*)
137	Transmitter-camshaft end-play adjustment.	(*)	(*)
138	Cam-stop lever-latch end-play adjustment.	(*)	(*)
139	Universal-bar adjustment....	(*)	(*)
140	Repeat-blocking-lever adjustment.		(*)
141	Sensing-levers alignment and end-play adjustments.	(*)	(*)
142	Selector-levers and sensing-levers clearance adjustment.	(*)	(*)
143	Selector-levers end-play adjustment.	(*)	(*)
144	Sensing-lever locking-bail adjustment.	(*)	(*)
145	Transmitter friction-clutch adjustment.	(*)	(*)
146	Transmitter friction-clutch adjustment.		(*)
147	Transmitter contact adjustment.	(*)	(*)
148	Start-stop selector-lever-latch adjustment.	(*)	(*)
149	Keyboard-transmitter impulse length adjustment.	(*)	(*)
150	Code ring and locking-bail cam-follower-lever end-play adjustment.		(*)

Par. No.	Name	TT-4A/TG	TT-4B/TG
151	Function sensing-lever end-play adjustment.	(*)	(*)
152	Function-shaft driven gear end-play adjustment.	(*)	(*)
153	Function-cam assembly alignment.	(*)	
154	Function-cam assembly alignment.		(*)
155	Function-shaft drive-collar adjustment.		(*)
156	Line-feed and figures-shift cam-followers clearance adjustment.	(*)	(*)
157	Function stop-bar guide adjustment.	(*)	(*)
158	Code-ring locking-bail cam-follower adjustment.		(*)
159	Locking-bail shaft adjustment.		(*)
160	Code-ring locking-bail adjustment.		(*)
161	T-lever alignment adjustment.	(*)	(*)
162	Transfer-lever-shaft end-play adjustment.	(*)	(*)
163	Transfer-lever roller-stud adjustment.	(*)	(*)
164	Transfer-lever-spring tension adjustment.		(*)
165	Y-lever eccentric-stop preliminary adjustment.	(*)	(*)
166	T-lever pivot stud adjustment.	(*)	(*)
167	Y-lever stud bracket adjustment.		(*)
168	Function-clutch clearance adjustment.	(*)	(*)
169	Function-clutch latch adjustment.	(*)	(*)
170	Function-clutch eccentric post adjustment.		(*)
171	Y-lever detent end-play adjustment.		(*)
172	Y-lever detent and Y-lever adjustment.		(*)
173	Y-lever friction adjustment..	(*)	
174	Selector friction-clutch adjustment.	(*)	
175	Selector friction-clutch adjustment.		(*)
176	Rangefinder shaft adjustment.	(*)	(*)
177	Orientation lever adjustment.	(*)	(*)
178	Selector-lever adjustment....	(*)	(*)
179	Selector-lever comb adjustment.	(*)	(*)
180	Selector-magnet armature adjustment.	(*)	

Par. No.	Name	TT-4A/TG	TT-4B/TG	Par. No.	Name	TT-4A/TG	TT-4B/TG
181	Selector-magnet armature adjustment.	(*)	211	Carriage-return blocking-lever adjustment.	(*)
182	Stop-lever adjustment.....	(*)	(*)	212	Carriage-feed blocking-lever adjustment.	(*)	(*)
183	Armature upper-stop-screw adjustment.	(*)	(*)	213	Right-margin stop-screw adjustment.	(*)
184	Armature lower-stop-screw adjustment.	(*)	(*)	214	Carriage-return adjusting-plate adjustment.	(*)
185	Selector-magnet adjustments.	(*)	(*)	215	Throw-out lever adjustment.	(*)
186	Selector-magnet armature and selector-lever clearance adjustment.	(*)	(*)	216	Carriage-return-clutch adjustment.	(*)
187	Function punch-bar and side-plate adjustment.	(*)	(*)	217	Carriage-return-link adjustment.	(*)
188	Function-lever-bracket adjustment.	(*)	(*)	218	Carriage-return latch-tripping-arm adjustment.	(*)
189	Letters-shift-lever shaft end-play adjustment.	(*)	(*)	219	Carriage-feed friction-clutch adjustment.	(*)	(*)
190	Function-clutch tension adjustment.	(*)	220	Carriage-return friction-clutch adjustment.	(*)	(*)
191	Function-shaft flexible-coupling disk adjustment.	(*)	221	Fulcrum adjustment.....	(*)
192	Adjustment of angular relationship of function-shaft parts.	(*)	222	Square-shaft driven-gear adjustment.	(*)	(*)
193	Function-cam adjustment...	(*)	(*)	223	Carriage rear-support bracket adjustment.	(*)	(*)
194	Carriage-feed ratchet adjustment.	(*)	(*)	224	Type-selecting-arm and function-selecting-arm adjustments.	(*)	(*)
195	Carriage-feed shaft drive-collar adjustment.	(*)	225	Square-shaft stop-arm torque adjustment.	(*)	(*)
196	Carriage-feed driving gear end-play adjustment.	(*)	(*)	226	Printing-bail-blade adjustment.	(*)	(*)
197	Carriage-feed driven gear adjustment.	(*)	(*)	227	Printing-bail and ribbon-lifter adjustments.	(*)	(*)
198	Carriage-feed pawl adjustment.	(*)	(*)	228	Platen-trough-spring adjustment.	(*)	(*)
199	Carriage-return clutch-lever shaft clearance adjustment.	(*)	(*)	229	Platen-shaft end-play adjustment.	(*)	(*)
200	Carriage-return clutch-actuating-lever adjustment.	(*)	230	Platen-trough end-play adjustment.	(*)	(*)
201	Carriage-return clutch adjustment.	(*)	231	Paper-guide adjustment.....	(*)
202	Carriage-feed-clutch drum adjustment.	(*)	(*)	232	Platen pressure-roller adjustment.	(*)
203	Decelerating cam and carriage-feed-clutch positioning adjustment.	(*)	233	Platen pressure-rollers adjustment.	(*)
204	Carriage-return latch-tripping-arm adjustment.	(*)	234	Platen-assembly end-play and positioning adjustment.	(*)	(*)
205	Square-shaft sliding-gear bearing adjustment.	(*)	(*)	235	Character-printing density adjustment.	(*)	(*)
206	Carriage position adjustment.	(*)	(*)	236	Figures-shift preliminary adjustment.	(*)	(*)
207	Ball bearing adjustment.....	(*)	(*)	237	Figures-shift position adjustment.	(*)	(*)
208	Carriage-rack adjustment....	(*)	(*)	238	Letters-shift position adjustment.	(*)
209	Carriage-rack drive-shaft position adjustment.	(*)	(*)	239	Letters-shift position adjustment.	(*)
210	Carriage-feed blocking adjusting lever and carriage-return blocking-lever clearance adjustment.	(*)	240	Platen-shift final adjustment.	(*)	(*)
				241	Platen-blocking-arm adjustment.	(*)

on the cam shaft; and tighten the set screws. Remove the feeler gage.

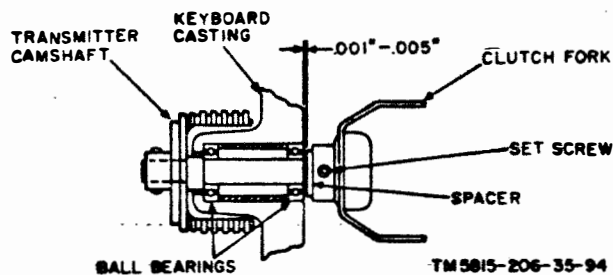

Figure 131. Transmitter-camshaft end-play adjustment.

138. Cam-Stop Lever-Latch End-Play Adjustment (fig. 132)

a. Requirement. There should be a .002- to .005-inch clearance between the cam-stop-lever latch and the keyboard casting.

b. Adjustment. Loosen the setscrew and position the cam-stop-lever-latch stud to meet the requirement in *a* above. Tighten the setscrew and recheck the requirement.

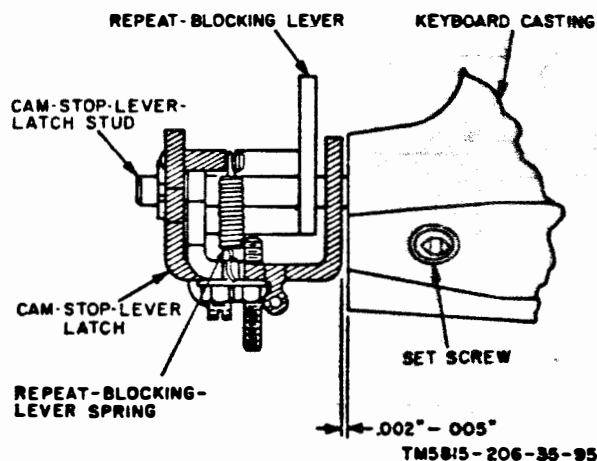

Figure 132. Cam-stop lever-latch end-play adjustment.

139. Universal-Bar Adjustment (fig. 133)

a. Requirement. There should be .005- to .015-inch clearance between the cam-stop lever and the cam-stop-lever latch when any key-lever is in the depressed position.

b. Method of Checking. Depress each key-lever and see that the clearance between the

cam-stop lever and the cam-stop-lever latch meets the requirement.

c. Adjustment. Loosen the lock nut and turn the universal-bar adjusting screw in or out to meet the requirement. Tighten the lock nut and recheck the clearance.

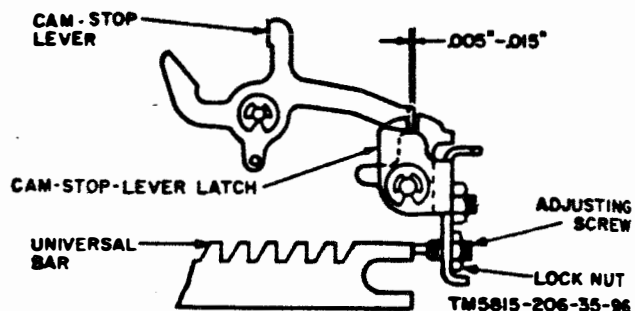

Figure 133. Universal-bar adjustment.

140. Repeat-Blocking-Lever Adjustment (TT-4B/TG) (fig. 134)

a. Requirement. There should be .045- to .050-inch clearance between the upper edges of the repeat-blocking lever and cam-stop-lever latch when the cam-stop lever is in the restored (counterclockwise) position.

b. Method of Checking. Rotate the transmitter camshaft manually until the cam-stop lever is in the restored position and the camshaft no longer turns. Measure the clearance between the repeat-blocking lever and cam-stop-lever latch.

c. Adjustment. Loosen the locknut that secures the repeat-blocking-lever adjusting screw and turn the screw in or out to meet the requirement. Tighten the nut and recheck the clearance.

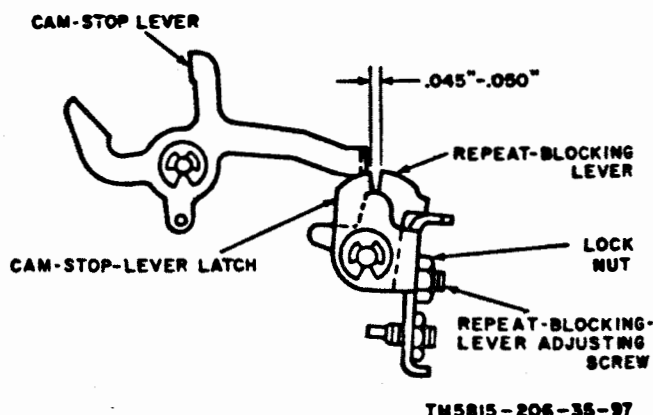

Figure 134. Repeat-blocking-lever adjustment (TT-4B/TG).

141. Sensing-Levers Alignment and End-Play Adjustments (fig. 135)

a. Requirements.

- (1) Each sensing lever should be in alignment (visual check) with its associated code bar.
- (2) There should be a .001- to .003-inch clearance between the No. 1 sensing lever and the outer spacer when the No. 1 sensing lever is pressed toward the keyboard casting.

b. Adjustments.

- (1) Loosen the setscrew in the keyboard casting and slowly pull the pivot stud outward until the laminated washer can be removed.
 - (a) If the sensing levers, as a group, were too close to the keyboard casting, insert a new laminated washer, peeled to size, to meet requirement a(\$) above.
 - (b) If the sensing levers were too far from the keyboard casting, peel laminations from the old washer and install the old washer to obtain the required alignment.
- (2) Insert a .002-inch feeler gage between the outer spacer and the No. 1 sensing lever; press the pivot stud toward the keyboard casting; tighten the setscrew; and remove the feeler gage.

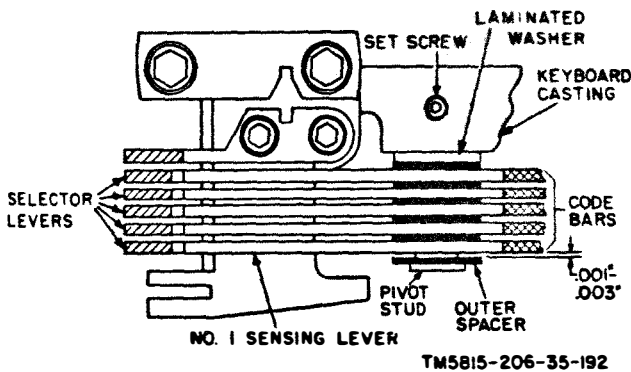

Figure 135. Sensing-levers alignment and end-play adjustments.

142. Selector-Levers and Sensing-Levers Clearance Adjustment (fig. 136)

a. Requirement. There should be a .005-inch minimum clearance between each selector lever

and its associated sensing lever when the selector lever is against a low part of its associated code-impulse cam and the sensing lever is in the counterclockwise position.

b. Adjustment. Loosen the mounting screws; position the selector-lever comb to meet the requirement; and tighten the mounting screws. Check the start-stop selector-lever latch adjustment (par. 148).

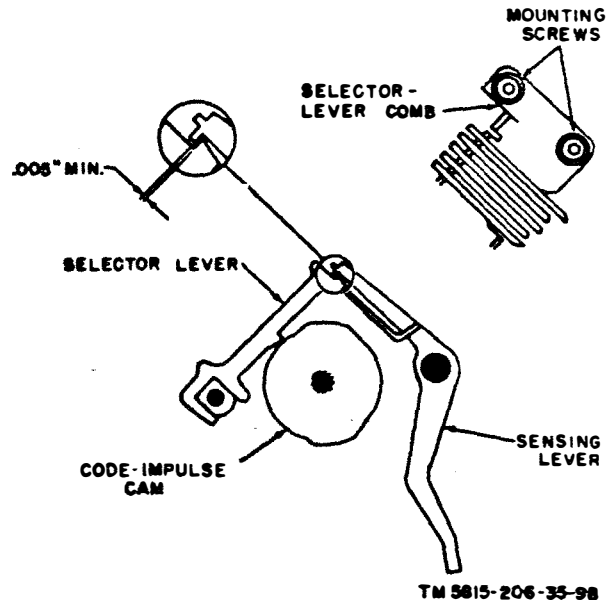

Figure 136. Selector-levers and sensing-levers clearance adjustment.

143. Selector-Levers End-Play Adjustment (fig. 137)

a. Requirement. There should be a .001- to .007-inch clearance between the laminated spacer and the No. 1 selector lever.

b. Adjustment. Remove parts as necessary to gain access to the laminated washer. Either remove laminations from the washer or insert a new laminated washer, peeled to size, to meet the requirement. Reassemble the parts

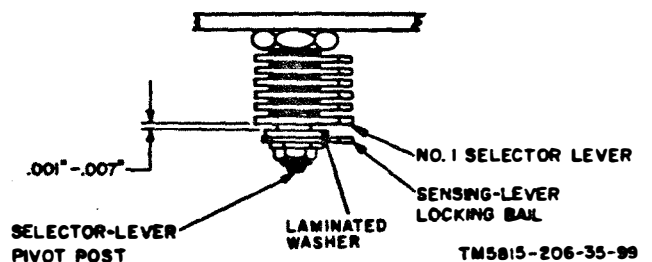

Figure 137. Selector-levers end-play adjustment.

and recheck the clearance. Check the sensing-lever locking-bail adjustment (par. 144).

144. Sensing-Lever Locking-Bail Adjustment (fig. 138)

a. Requirement. There should be equal clearance between the blade of the sensing-lever locking bail and the projections on the upper end of the sensing levers.

b. Method of Checking. Depress R or Y key-lever. Turn the transmitter camshaft clockwise by hand until the blade of the sensing-lever locking bail engages the sensing levers. Check the clearances visually.

c. Adjustment. Loosen the locknut and turn the eccentric bearing clockwise or counterclockwise until the clearances are equal. Tighten the locknut and recheck the clearances.

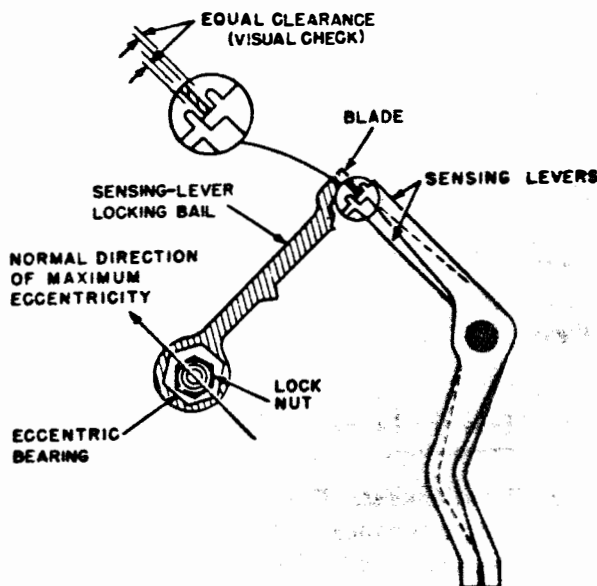

TM5815-206-35-226

Figure 138. Sensing-lever locking-bail adjustment.

145. Transmitter Friction-Clutch Adjustment (TT-4A/TG) (fig. 139)

a. Requirements.

- (1) There should be a .005- to .025-inch clearance between the collar of the friction-clutch disk and the bearing of the clutch fork.
- (2) A pull of 25 to 30 ounces should be required to prevent the clutch fork from turning when the motor is on and

the transmitter camshaft is not operating any levers.

b. Method of Checking.

- (1) Insert a flat feeler gage between the collar of the friction-clutch disk and the bearing of the clutch fork to determine the clearance.
- (2) Engage one arm of the clutch fork with the hooked end of a spring scale. Hold the scale tightly and turn the motor on. Press the space bar; allow the transmitter camshaft to turn slightly until none of the cams are operating a lever; and read the scale.

c. Adjustments.

- (1) Loosen the two setscrews in the collar of the friction-clutch disk; position the disk until requirement *a*(1) above is met; and tighten the two setscrews.
- (2) Loosen the setscrews in the friction-adjusting collar and move the collar to increase or decrease compression of the friction-clutch spring, as necessary, to meet requirement *a*(2) above. Tighten the setscrews and recheck the requirement.

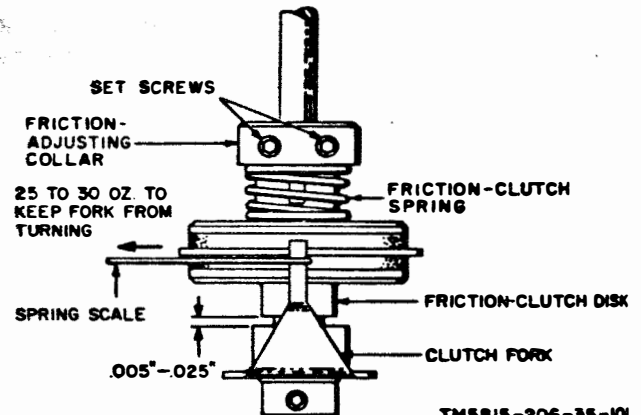

TM5815-206-35-101

Figure 139. Transmitter friction-clutch adjustment (TT-4A/TG).

146. Transmitter Friction-Clutch Adjustment (TT-4B/TG) (fig. 140)

a. Requirements.

- (1) There should be .005- to .025-inch clearance between the collar of the friction-clutch disk and the bearing of the clutch fork.

- (2) A pull of 25 to 30 ounces should be required to prevent the clutch fork from turning when the motor is on and the transmitter camshaft is not operating any levers.

b. Method of Checking.

- (1) Insert a flat feeler gage between the collar of the friction-clutch disk and the bearing of the clutch fork to determine the clearance.
- (2) Engage one arm of the clutch fork with the hooked end of a spring scale. Hold the scale rigid; depress the space bar; allow the camshaft to turn slightly until none of the cams is operating a lever; and read the scale.

c. Adjustments.

- (1) Loosen the two setscrews in the collar of the friction-clutch disk and position the disk until requirement of *a*(1) above is met. Tighten the two setscrews.
- (2) Loosen the clamping screws in the friction-adjusting collar and turn the adjusting collar clockwise or counterclockwise to obtain requirement *a*(2) above. Tighten the clamping screws and recheck the requirement.

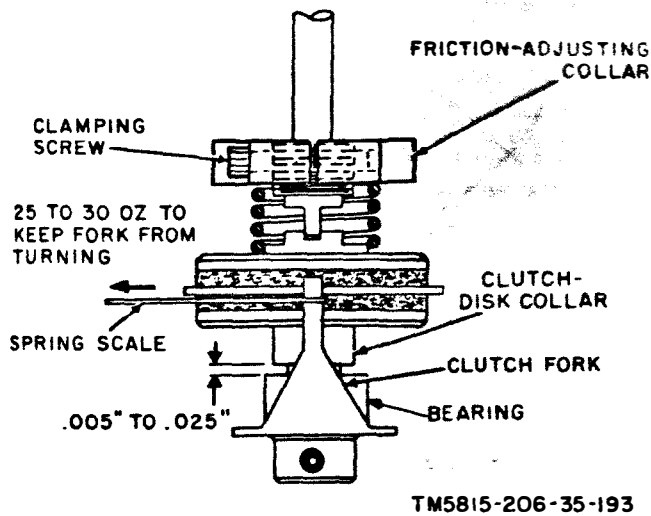

Figure 140. Transmitter friction-clutch adjustment (TT-4B/TG).

147. Transmitter Contact Adjustment
(fig. 141)

a. Requirement. There should be slight, but minimum, breaks in the signal circuit between

successive marking impulses when the transmitter camshaft is turned manually.

b. Method of Checking. Connect a millimeter in series with the signal circuit. Press the LTRS keylever; slowly turn the motor by hand and observe the meter pointer as the transmitter camshaft revolves slowly.

c. Adjustment. Turn the transmitter contact toward the contact bail until no breaks occur between successive marking impulses. Then slowly turn the contact away from the contact bail until a slight break occurs between marking impulses. If Distortion Test Set TS-383/GG is available, perform the transmitter impulse length adjustment (par. 149).

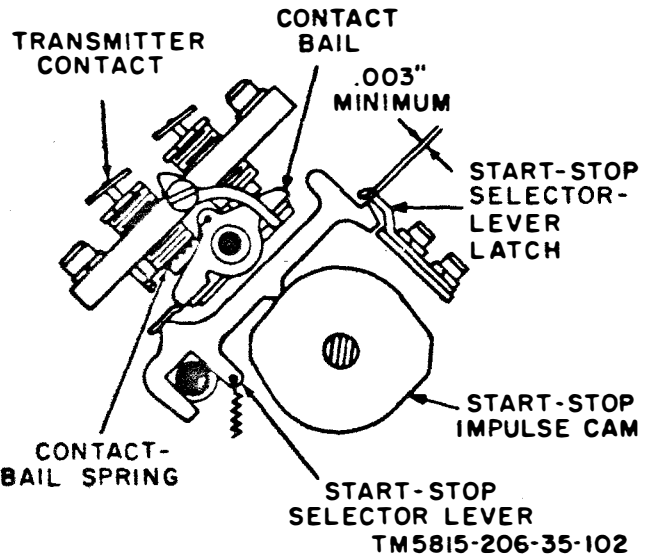

Figure 141. Transmitter contact and start-stop selector-lever-latch adjustments.

148. Start-Stop Selector-Lever-Latch Adjustment
(fig. 141)

a. Requirement. There should be a slight, but minimum, break in the signal circuit between transmission of a fifth code impulse (marking) and the stop impulse when the transmitter camshaft is turned manually. There should be a .003-inch minimum clearance between the start-stop selector lever and the start-stop selector-lever latch when the selector lever is against a low portion of its cam.

b. Method of Checking. Connect a millimeter in series with the signal circuit. Press the T keylever; turn the motor slowly by hand; and

observe the meter as the fifth code impulse end and the stop impulse begins. Check the clearance between the start-stop selector lever and the start-stop selector-lever latch with a feeler gage.

c. Adjustment. Loosen the machine screws that hold the start-stop selector-lever latch. Move the latch to the right or left until a minimum break is obtained between the marking fifth code impulse and the stop impulse. Move the latch to the right to decrease the break and to the left to increase the break. When the start-stop selector lever is against a low part of its cam, check the clearance between the selector lever and its latch. If the clearance is less than .003 inch, repeat the selector-levers and sensing-levers clearance adjustment (par. 142). Then reposition the start-stop selector-lever latch to meet requirement *a*(2) above.

149. Transmitter Impulse Length Adjustment (fig. 142)

Note. This adjustment requires the use of Distortion Test Set TS-383/GG and normally is performed at fourth- and fifth- echelon maintenance shops only.

a. Requirements.

- (1) The time length of each of the five code impulses (neutral operation) should be 100 (± 5) divisions on the measuring scale of the TS-383/GG.
- (2) The time length of the stop impulse (neutral operation) should be 142 (± 7) divisions.
- (3) Each impulse should begin within five divisions of the zero marking on the measuring scale of the test set and should end within five divisions of the zero marking for the next impulse.

b. Method of Checking.

- (1) Prepare the teletypewriter and the distortion test set for 100-wpm operation.
- (2) Check the keyboard-transmitter friction clutch adjustment (par. 145 and 146); readjust the clutch if necessary.
- (3) Remove the repeat-blocking-lever spring (fig. 132).
- (4) Turn on the motor of the teletypewriter and the motor of the test set. Press the LTRS keylever and turn the measuring scale of the test set to align the visible impulses with their respective segments on the measuring

scale. Check each impulse for its applicable requirements (*a* above).

- (5) If the requirements are set, replace the repeat-blocking-lever spring (fig. 132) and restore the teletypewriter for 60-wpm operation (unless it is to be used for 100-wpm operation).

c. Adjustments.

- (1) Perform steps *b*(1) through (3) above.
- (2) Adjust the mark transmitter contact until requirements *a*(1) and *a*(3) above are met.
- (3) Adjust the position of the start-stop selector-lever latch to meet requirements *a*(2) and *a*(3) above.
- (4) Perform step *c*(5) above.

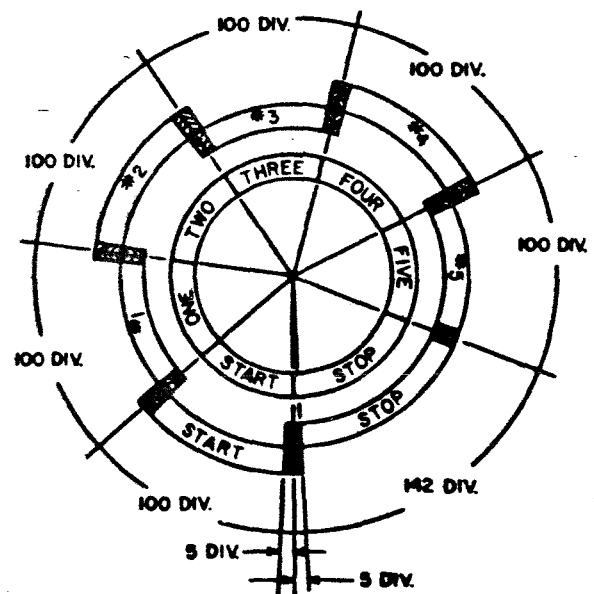

TM3815-206-35-103

Figure 142. Transmitter impulse length requirements.

150. Code Ring and Locking-Bail Cam-Follower-Lever End-Play Adjustment (TT-4B/TG) (fig. 143)

Note. This adjustment should be made only when the code-ring cage has been removed from the machine (par. 104a).

a. Requirements.

- (1) There should be .002- to .004-inch clearance between the code-ring collar and the ball retainer.

- (2) There should be .002- to .010-inch clearance between the sleeve bearing and the locking-bail cam-follower lever.

b. Method of Checking.

- (1) Insert a flat feeler gage upward from the bottom of the code-ring cage into the space between the code-ring collar and the ball retainer.
- (2) Insert a flat feeler gage upward from the bottom of the code-ring cage into the space between the sleeve bearing and the locking-bail cam-follower lever.

c. Adjustment. Loosen the two setscrews that clamp the code-ring collar and the sleeve bearing to the shaft of the code-ring cage. (One setscrew is accessible from the bottom of the code-ring cage. To loosen the other setscrew, insert a wrench between the top center stop bars and through the access hole in the code-ring cage spacer.) Insert a .003-inch flat feeler gage between the ball retainer and code-ring collar; hold the gage in place, shift the sleeve bearing to meet the requirement in a(2) above; and tighten the setscrews. Recheck the clearance.

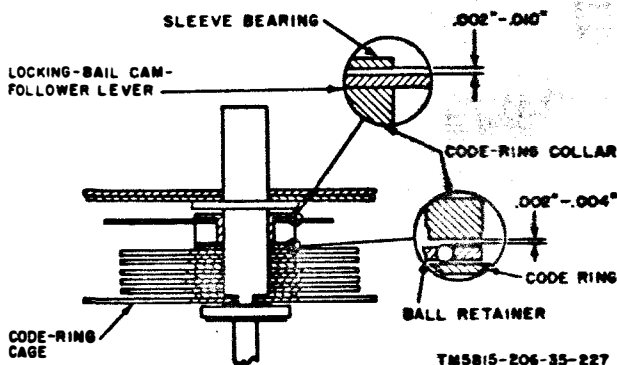

Figure 143. Code ring and locking-bail cam-follower-lever end-play adjustment (TT-4B/TG).

151. Function-Sensing-Levers End-Play Adjustment (fig. 144)

Note. Perform this adjustment whenever the code-ring cage is changed, replaced, or removed (par 104a).

a. Requirement. There should be .001- to .005-inch clearance between the flat washer and the line-feed sensing lever.

b. Method of Checking. Use flat feeler gages

to check the clearance between the line-feed sensing lever and the flat washer.

c. Adjustment. Remove the code-ring cage and either peel as many laminations as necessary from the laminated washer or install a new laminated washer, peeled to size. Remove all burrs from the laminated washer. Reassemble the parts, recheck the clearance, and remove additional laminations, if necessary. Check related adjustments (par. 157, 158, 166, and 222).

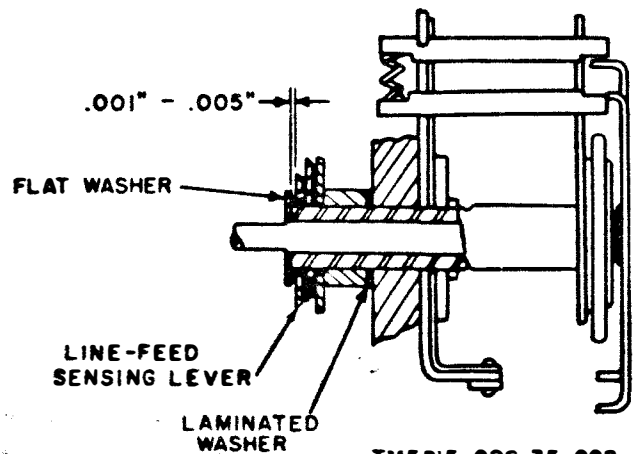

Figure 144. Function-sensing-levers end-play adjustment.

152. Function-Shaft Driven Gear End-Play Adjustment (fig. 145)

a. Requirement. There should be a .001- to .004-inch clearance between the function-shaft driven gear and the inner flat washer when the driven gear is pressed against the outer flat washer.

b. Adjustment.

- (1) Remove the function-shaft assembly (par. 98a).
- (2) Remove the function cam (44, fig. 102), sleeve bearing (45), print cam (42), flexible coupling disk (40), clutch spring (38), function-clutch drum (37), retainer ring (36), and flat washer (35).
- (3) Add or remove spacers (34) as required; replace the flat washer and retainer ring; and recheck the clearance.
- (4) Reassemble and install the function-shaft assembly (par. 98b).

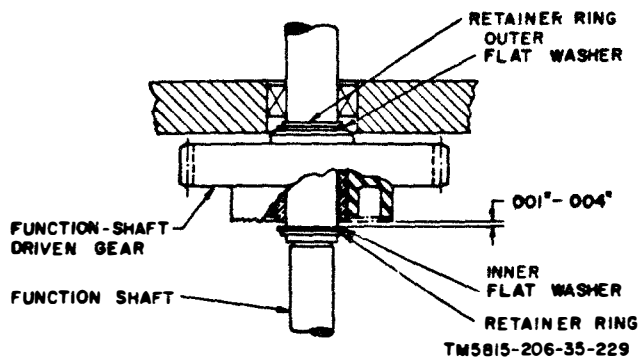

Figure 145. Function-shaft driven gear end-play adjustment.

- (5) Check all related adjustments (par. 161, 155, 225, and 168 through 170).

153. Function-Cam Assembly Alignment (TT-4A/TG)

(fig. 146)

a. Requirement. The function-sensing levers must be aligned with their respective cams on the function-cam assembly.

b. Adjustment. Remove the function-shaft assembly (par. 98a). Loosen the setscrews in the transfer-lever-restoring cam and remove the cam, bearing, and laminated washer from the end of the function shaft. Either peel laminations from the washer or install a new laminated washer, peeled to the proper thickness, to meet the requirement in *a* above. Remove all burrs from the laminated washer; replace the parts on the function shaft; and install the function-shaft assembly on the teletypewriter (par. 98b). Recheck the alignment (*a* above) and readjust if necessary. Check related adjustments (par. 156, 193, 161, 162, and 227).

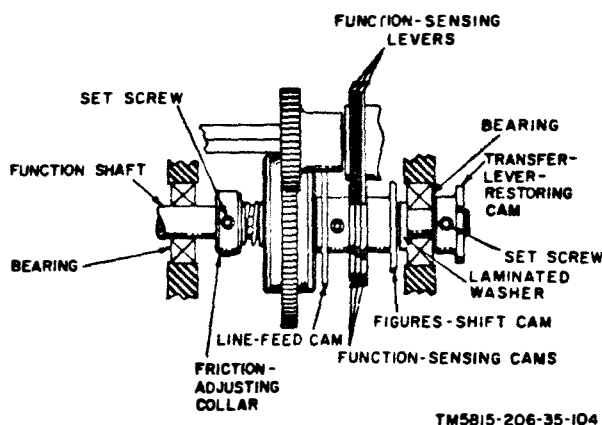

Figure 146. Function-cam assembly alignment (TT-4A/TG).

154. Function-Cam Assembly Alignment (TT-4B/TG)

(fig. 147)

a. Requirement. The function-sensing levers must be aligned with their respective cams on the function-cam assembly.

b. Adjustment. Remove the function-shaft assembly (par. 98a). Remove the mounting screw transfer-lever-restoring cam, locking-bail cam, bearing and laminated washer from the end of the function shaft. Either peel the laminated washer or install a new laminated washer, peeled to the proper thickness, to meet the requirement in *a* above. Remove all burrs from the laminated washer; replace the parts on the function shaft; tighten the mounting screw and install the function-shaft assembly in the teletypewriter (par. 98b). Recheck the alignment (*a* above) and readjust if necessary. Check related adjustments (par. 156, 192, 193, 161, 162, and 227).

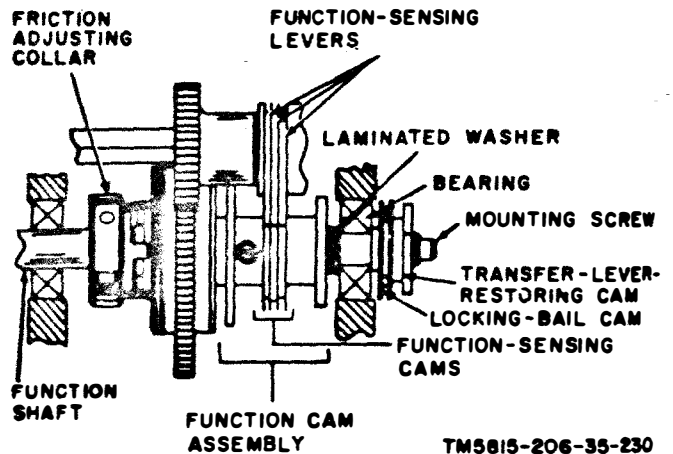

Figure 147. Function-cam assembly alignment (TT-4B/TG).

155. Function-Shaft Drive-Collar Adjustment (TT-4B/TG)

(fig. 148)

Note. This adjustment should be made only during disassembly and reassembly of the function shaft.

a. Requirement. There should be .015- to .030-inch clearance between the drive collar and the friction-clutch plate.

b. Adjustment. Remove the friction-adjusting collar (fig. 147), loosen the setscrews in the drive collar, and position the drive collar to meet the requirement in *a* above. Tighten the

setscrews and recheck the clearance. Replace the friction-adjusting collar and make the square-shaft stop-arm torque adjustment (par. 225).

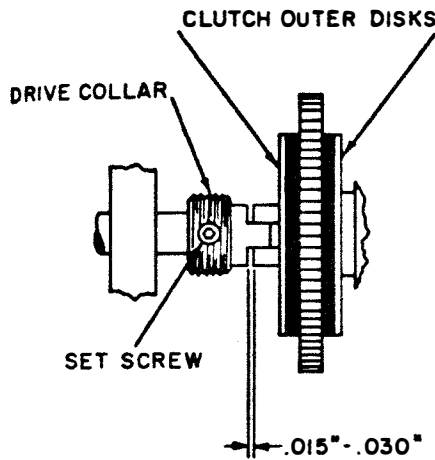

TM5815-206-35-105

Figure 148. Function-shaft drive-collar adjustment (TT-4B/TG).

156. Line-Feed and Figure-Shift Cam-Followers Clearance Adjustment (fig. 149)

a. Requirement. The clearance between the roller of the line-feed cam follower and the line-feed cam should equal the clearance be-

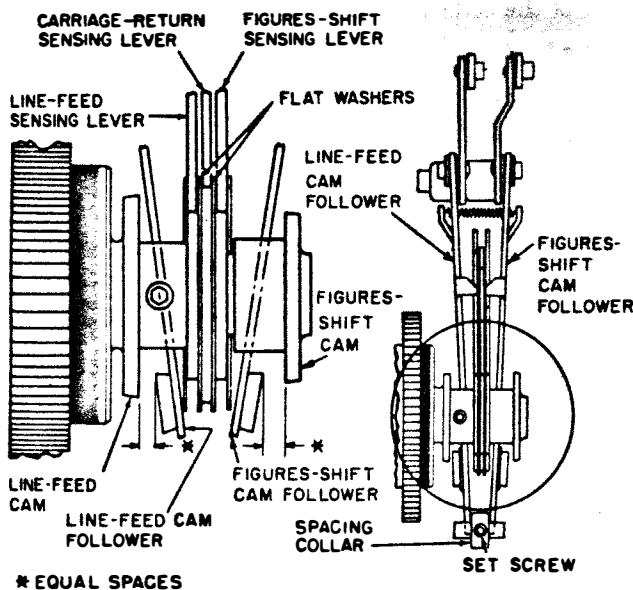

TM5815-206-35-194

Figure 149. Line-feed and figures-shift cam-followers clearance requirement.

tween the roller of the figures-shift cam follower and the figures-shift cam.

b. Adjustment. Loosen the setscrews in the spacing collar. Shift the collar right or left until the requirement in a above is met. Tighten the setscrews.

157. Function Stop-Bar Guide Adjustment (fig. 150)

a. Requirements. When the teletypewriter is in the stopped position there should be a .010- to .020-inch clearance between the carriage-return sensing lever (middle lever) and its associated function stop bar, and a .005-inch minimum clearance between the line-feed sensing lever and the figures-shift sensing lever and their associated function stop bars.

b. Adjustment. Loosen the two machine screws that mount the function stop-bar guide. Turn the function stop-bar guide either clockwise or counterclockwise until the requirements in a above are met. Tighten the machine screws. Check related adjustments (par. 158, 165, 166, and 224).

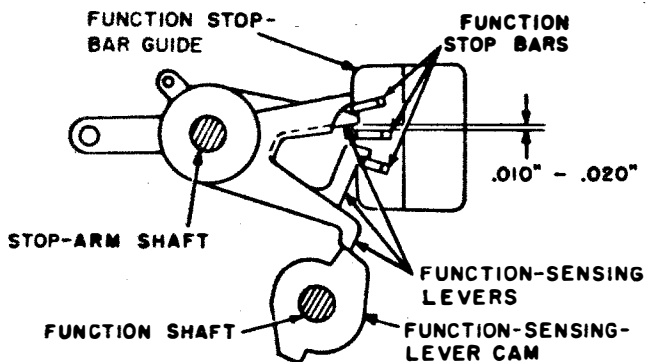

NOTE:
LINE-FEED (UPPER) AND FIGURES-SHIFT (LOWER) SENSING LEVERS CLEARANCES ARE .005" MIN.

TM5815-206-35-231

Figure 150. Function stop-bar guide adjustment.

158. Code-Ring Locking-Bail Cam-Follower Adjustment (TT-4B/TG) (fig. 151)

a. Requirement. The blade of the locking-bail lever should operate between the letters and J stop bars without touching either stop bar.

b. Adjustment. Loosen the mounting screw that holds the cam follower to the cam-follower lever. Position the cam follower until the requirement in a above is met. Tighten the mounting screw. Set up, alternately, letters

and J code groups on the code rings and check the requirement visually. Readjust if necessary. Check the related adjustment (par. 159).

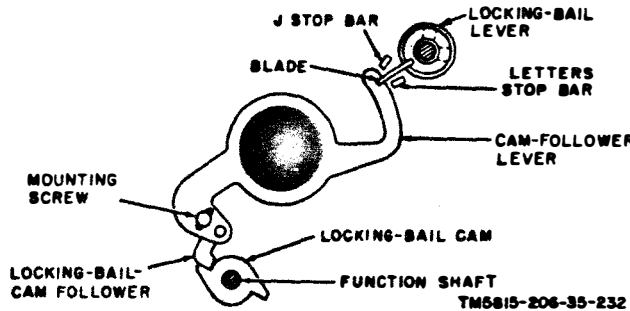

Figure 151. Code-ring locking-bail cam-follower adjustment (TT-4B/TG).

159. Locking-Bail Shaft Adjustment

(TT-4B/TG)

(fig. 152)

a. Requirements.

- (1) There should be .010- to .020-inch clearance between the code-ring locking bail and the code-ring projections (B, fig. 152) when the function shaft is in the stopped position.
- (2) There should be .002- to .005-inch end

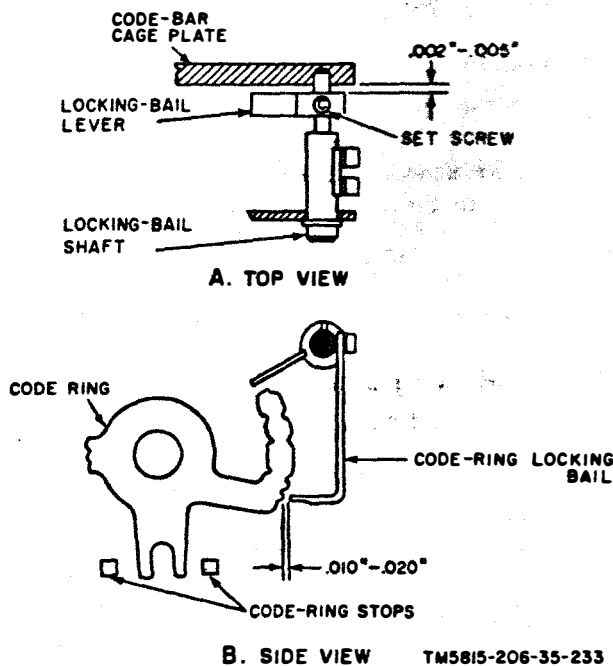

Figure 152. Locking-bail shaft adjustment (TT-4B/TG).

play in the locking-bail shaft (A, fig. 152).

b. Method of Checking.

- (1) Set the function shaft to the stopped position and place the No. 1 code ring so that its projection is aligned with the locking edge of the code-ring locking bail. Check requirement a(1) above with a feeler gage.
- (2) Insert a flat feeler gage between the collar of the locking-bail lever and the code-bar cage plate to determine the end play.

c. Adjustment. Loosen the setscrews in the collar of the locking-bail lever. Rotate the locking-bail shaft until the requirement in a(1) above is met. Position the locking-bail lever to obtain the requirement in a(2) above. Tighten the setscrews in the collar of the locking-bail lever and recheck both clearance requirements.

160. Code-Ring Locking-Bail Adjustment

(TT-4B/TG)

(fig. 153)

a. Requirement. The clearance between the code-ring locking bail and the locking projection on each code ring should be equal for both marking and spacing positions of the code ring.

b. Adjustment. Position the Y-levers for either R or Y code combination and pull the transfer-lever latch downward (fig. 156). Turn the motor by hand until the locking-bail spring pulls the code-ring locking bail against the code rings. Loosen the mounting screws and position the code-ring locking bail until the require-

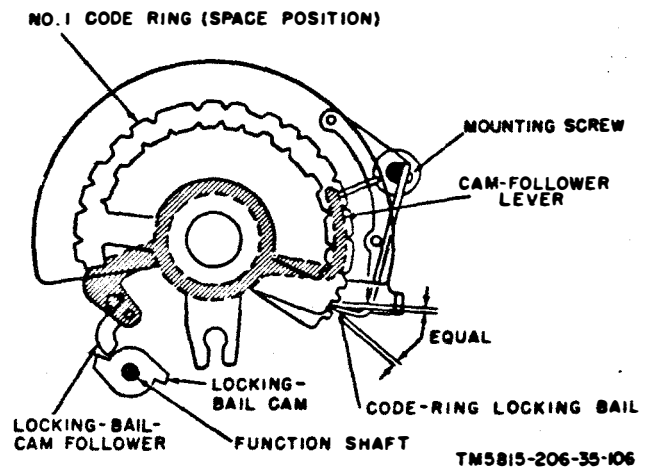

Figure 153. Code-ring locking-bail adjustment (TT-4B/TG).

ment is met. Tighten the mounting screws and recheck the clearances.

161. T-lever Alignment Adjustment

a. Requirement. The T-levers should be aligned as closely as possible with their respective Y-levers and code rings. Any offset between the Y-levers and code rings should be equally divided between the T-levers and Y-levers and between the T-levers and code rings (B, fig. 154).

b. Adjustment. On the TT-4A/TG, loosen the two setscrews in the front and rear shaft collars on the transfer-lever shaft. On the TT-4B/TG, loosen the clamping screws in the front and rear shaft collars (A, fig. 154). Slide

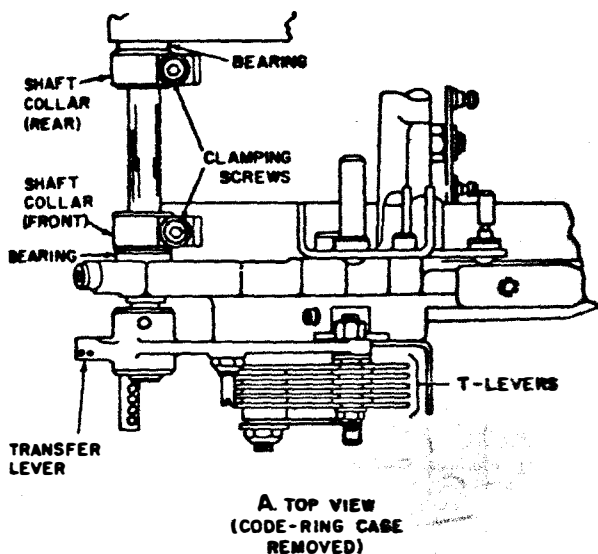

A. TOP VIEW
(CODE-RING CASE
REMOVED)

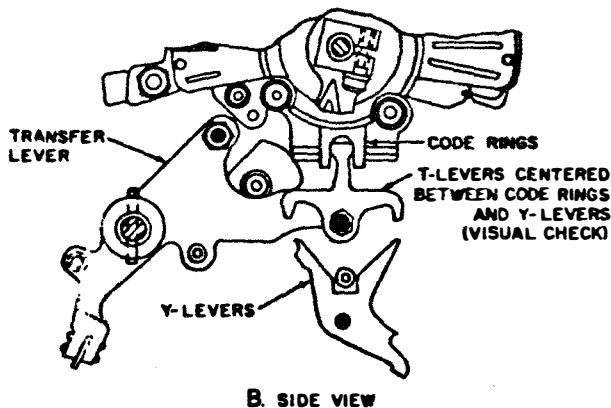

B. SIDE VIEW

TM5815-206-35-107

Figure 154. T-lever alignment adjustment.

the transfer lever in or out to meet the requirement in *a* above; slide the *front* shaft collar against the bearing; and tighten the clamping screw. Perform the transfer-lever-shaft end-play adjustment (par. 162) and check the related adjustment (par. 168).

162. Transfer-Lever-Shaft End-Play Adjustment

(fig. 155)

a. Requirement. There should be .002- to .005-inch clearance between the rear shaft collar on the transfer-lever shaft and the frame.

b. Adjustment. On the TT-4B/TG, loosen the clamping screw in the rear shaft collar. On the TT-4A/TG, loosen the setscrews in the rear shaft collar. Hold the front collar against the frame; move the rear collar to meet the requirement in *c* above; and tighten the clamping screw or setscrews.

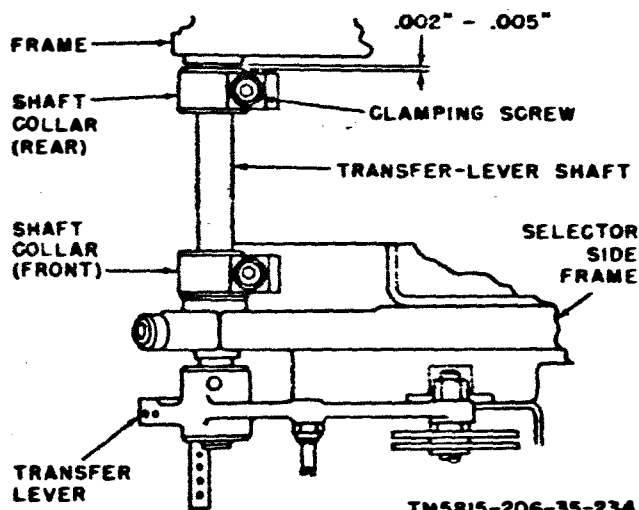

TM5815-206-35-234

Figure 155. Transfer-lever-shaft end-play adjustment.

163. Transfer-Lever Roller-Stud Adjustment

(fig. 156)

a. Requirement. There should be .007- to .020-inch clearance between the transfer lever and the latching surface of the transfer-lever latch when the transfer-lever roller is against a lobe of the transfer-lever restoring cam.

b. Adjustment. Loosen the self-locking hexagonal nut and set the transfer-lever-roller stud for maximum eccentricity. Rotate the motor of the teletypewriter by hand until the roller is against a lobe of the transfer-lever restoring cam. Turn the stud in a counterclockwise

direction until the required clearance is obtained, and tighten the self-locking hexagonal nut.

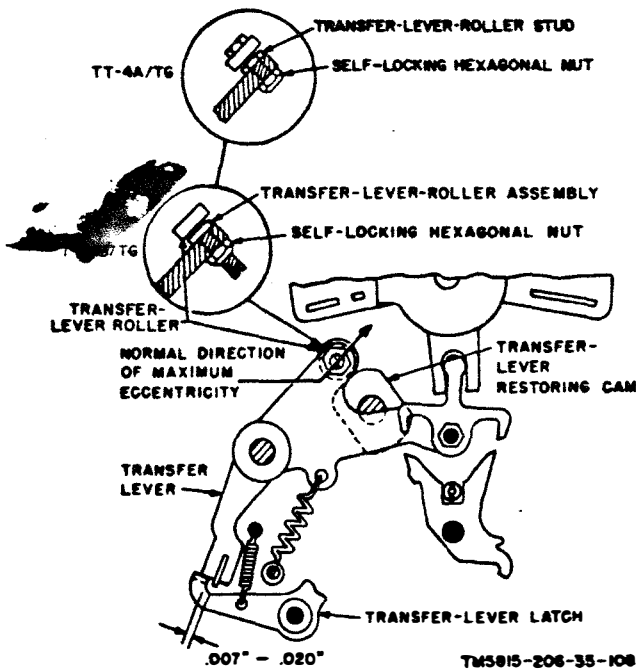

Figure 156. Transfer-lever roller-stud adjustment.

164. Transfer-Lever-Spring Tension Adjustment (TT-4B/TG) (fig. 157)

a. Requirement. A pull of $4\frac{1}{2}$ to $5\frac{1}{2}$ pounds should be required to start the transfer lever moving away from the transfer-lever restoring cam.

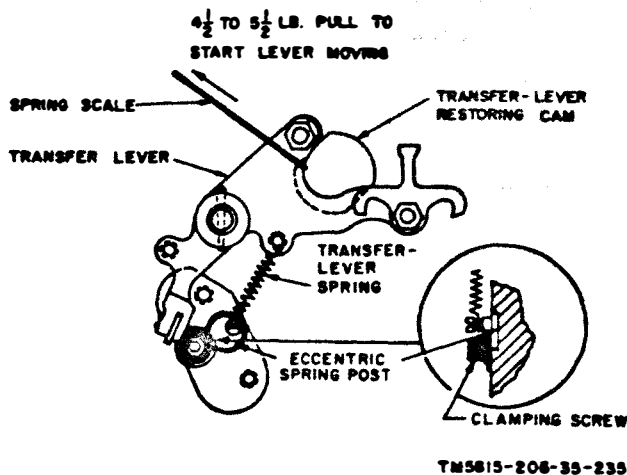

Figure 157. Transfer-lever-spring tension adjustment (TT-4B/TG).

b. Adjustment. Loosen the clamping screw; turn the eccentric spring post to meet the requirement in a above; and tighten the clamping screw.

165. Y-lever Eccentric Stop Preliminary Adjustment (fig. 158)

a. Requirement. The Y-lever eccentric stop should be positioned midway between the Y-levers.

Note. When making the following adjustment, be very careful to prevent damage to the function shaft when inserting the tool into the set screw.

b. Adjustment. Set the Y-levers for either R or Y code combination. Loosen the setscrew which locks the Y-lever eccentric stop. Pull the transfer-lever latch downward to cause the T-levers to engage the Y-levers. Turn the eccentric clockwise until it contacts the Y-levers that are in the space position. Note the position of the slot in the end of the stop. Now turn the eccentric stop counterclockwise until it contacts the Y-levers that are in the mark position. Note the position of the slot in the end of the stop. Turn the stop to a position midway between the two noted positions and tighten the setscrew. Check related adjustments (par. 169, 172, and 185).

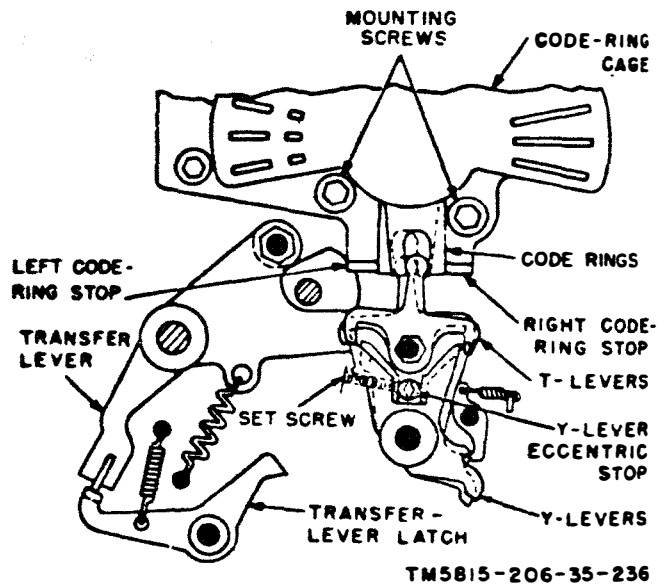

Figure 158. Y-lever eccentric stop preliminary adjustment.

166. T-lever Pivot Stud Adjustment (fig. 159)

a. Requirement. The T-levers should engage

the Y-levers an equal amount for both mark and space positions of the Y-levers.

b. Method of Checking. Turn the motor manually until the transfer lever is latched and the function shaft is in the stopped position. Set the Y-levers to the R code combination positions. Pull the transfer-lever latch downward to cause the T-levers to engage the Y-levers. Check the amount of engagement visually. Turn the motor manually to restore the transfer lever and the T-levers. Set the Y-levers to the Y code combination positions. Trip the transfer lever and check the amount of engagement visually.

c. Adjustment. Loosen the plain hexagonal nut on the rear of the T-lever pivot stud. Position the T-lever pivot stud to the normal direction of maximum eccentricity, as shown in figure 159. Then reposition the pivot stud to meet the requirement in *a* above. Tighten the nut. Check related adjustments (par. 165 and 169).

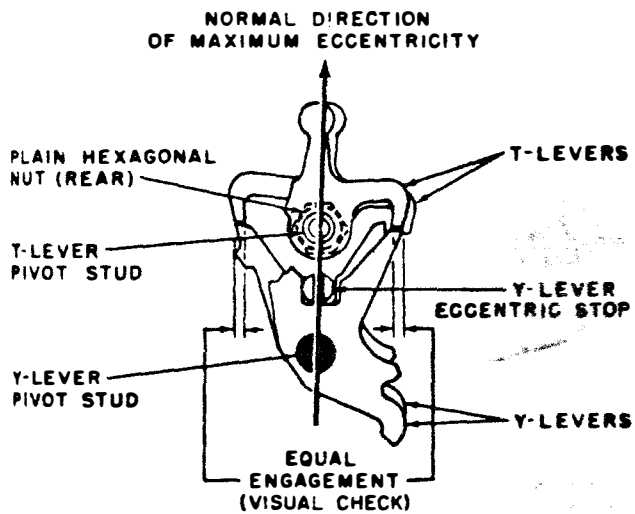

TM5815-206-35-237

Figure 159. T-lever pivot stud adjustment.

167. Y-lever Stud Bracket Adjustment (TT-4B/TG)

Note. The y-lever eccentric stop preliminary adjustment (par. 165) should be completed before this adjustment is performed.

a. Requirement.

- (1) There should be 0.002- to 0.005-inch clearance between the spacer and the flat washer (A, fig. 160).

- (2) The Y-lever eccentric stop and the Y-lever pivot stud should be locked in place by the Y-lever eccentric tie (B, fig. 160).

b. Method of Checking. Check the requirement in *a*(1) with feeler gages; check the requirement in *a*(2) visually to make sure that the Y-lever eccentric tie is engaging the Y-lever eccentric stop. Check to make sure that the clamping screw of the Y-lever stud bracket and the mounting screws of the Y-lever eccentric tie are tight.

c. Adjustment.

- (1) Loosen the mounting screws of the Y-lever eccentric tie and the clamping screw of the Y-lever stud bracket. Position the bracket to meet the requirement in *a*(1) above. Tighten the clamping screw.
- (2) Shift the Y-lever eccentric tie to engage the Y-lever eccentric stop. Tighten the mounting screws.

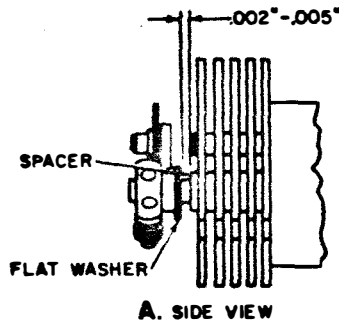

A. SIDE VIEW

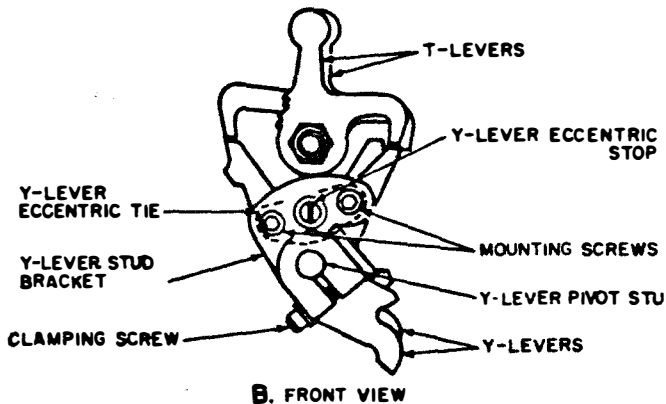

B. FRONT VIEW

TM5815-206-35-109

Figure 160. Y-lever stud bracket adjustment (TT-4B/TG).

168. Function-Clutch Clearance Adjustment (fig. 161)

a. Requirement. There should be 0.010- to 0.020-inch clearance between the function-clutch drum and the clutch teeth of the function-shaft driven gear when the function-clutch latch engages an arm of the function-clutch drum and the function-shaft driven gear is pressed toward the clutch drum.

b. Method of Checking. Place the teletypewriter in the stopped position. Press the function-shaft driven gear toward the function-clutch drum and insert a flat feeler gage between the gear and the clutch drum. Repeat the check when the opposite arm of the clutch drum is engaged by the function-clutch latch.

c. Adjustment. Loosen the clamping screw in the function-clutch latch. Loosen the two setscrews in the shaft collar of the TT-4A/TG. On the TT-4B/TG, loosen the clamping screw in the shaft collar. Press the latch and shaft collar together and adjust the position of both to meet the requirement. Tighten only the clamping screw or setscrews in the shaft collar. Then perform the function-clutch latch adjustment (par. 169).

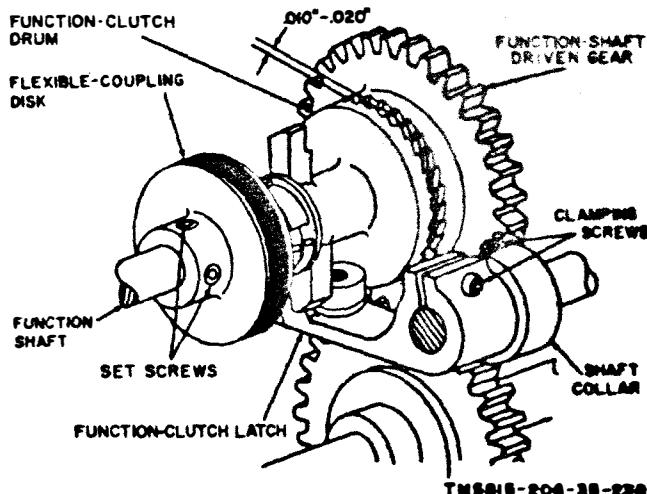

Figure 161. Function-clutch clearance adjustment.

169. Function-Clutch Latch Adjustment (fig. 162)

a. Requirement. There should be 0.015- to 0.020-inch clearance between the function-clutch latch or its ball bearing, whichever is

higher, and the adjacent arm of the function-clutch drum when the clutch is engaged.

b. Method of Checking. Then the motor manually until the transfer lever is latched and the function shaft is in the stopped position. Pull the transfer-lever latch downward to disengage the function-clutch latch from an arm of the function-clutch drum. Check the clearance with a feeler gage. Turn the motor manually and check the clearance when the opposite arm is adjacent to the latch.

c. Adjustment. Loosen the clamping screw in the function-clutch latch. Position the latch to meet the requirement. Tighten the clamping screw and recheck the clearance.

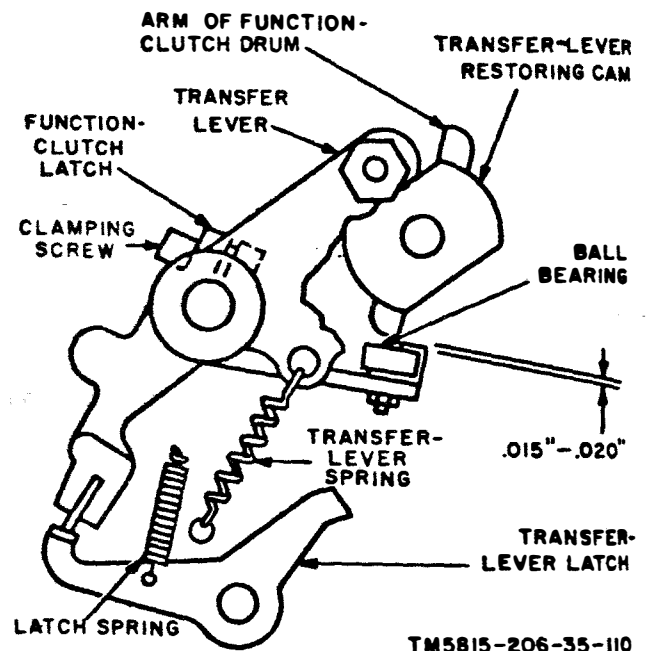

Figure 162. Function-clutch latch adjustment.

170. Function-Clutch Eccentric Post Adjustment (TT-4B/TG) (fig. 163)

a. Requirement. When the clutch is engaged, there should be a 0.003- to 0.015-inch clearance between the eccentric post and an adjacent high part of the function clutch drum.

b. Adjustment. Engage the clutch members and loosen the lock nut. Adjust the eccentric post to meet the requirement in *a* above. Rotate the function shaft $\frac{1}{2}$ -turn and recheck the clearance. When both clearances are within the required tolerance, tighten the lock nut.

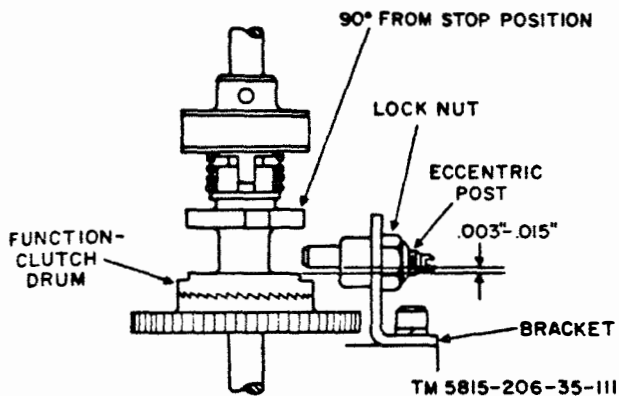

Figure 163. Function-clutch eccentric post adjustment (TT-4B/TG).

171. Y-lever Detent End-Play Adjustment (TT-4B/TG) (fig. 164)

a. Requirement. Each Y-lever detent should engage its associated Y-lever by at least 25 percent of the thickness of the Y-lever detent. There should be a .002- to .005-inch clearance between the first thrust washer and the centering sleeve.

b. Method of Checking. Move the Y-lever detents back and forth while checking the engagement requirement visually. Check the clearance requirement with a feeler gage.

c. Adjustment. Remove the plain hexagonal nut and lockwasher. Slide the centering sleeve

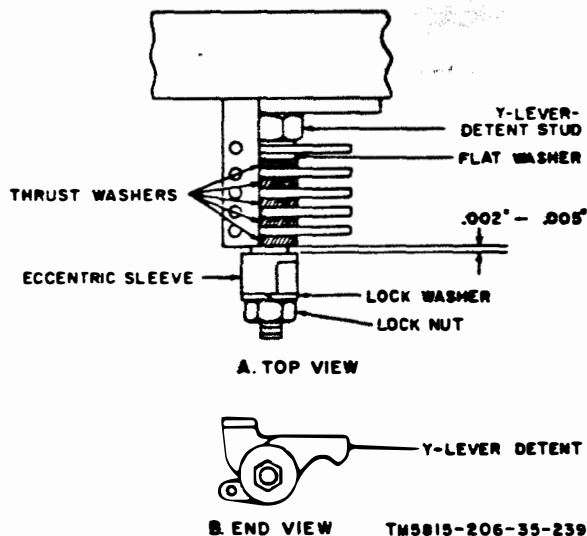

Figure 164. Y-lever detent end-play adjustment (TT-4B/TG).

and detents off the Y-lever-detent pivot. Replace the flat washer with a laminated washer peeled to meet the requirement. Replace the parts on the pivot, tighten the nut, and check the requirement.

Note. Do not insert a peeled laminated washer less than .005 inch thick. Laminated washers may become bowed when peeled. Make certain that washers are flat before inserting.

172. Y-lever Detent Engagement Adjustment (TT-4B/TG) (fig. 165)

a. Requirement.

- (1) There should be an equal engagement of the Y-lever detent with the Y-lever when the Y-lever is in either mark or space position (visual check).
- (2) A force of 30 to 60 grams should be required to start each Y-lever moving.

b. Adjustment.

- (1) Loosen the plain hexagonal nut (fig. 164) and turn the centering sleeve to meet requirement a above.
- (2) Replace a Y-lever-detent spring which does not meet the tension requirement (par. 279). If the spring tension is satisfactory, check for binding between the Y-lever and its adjacent washers and between the Y-lever detent and its adjacent washers; remove the cause of binding.

173. Y-lever Friction Adjustment (TT-4A/TG) (fig. 166)

a. Requirement. A force of 40 to 50 grams, applied with a spring scale at the point shown

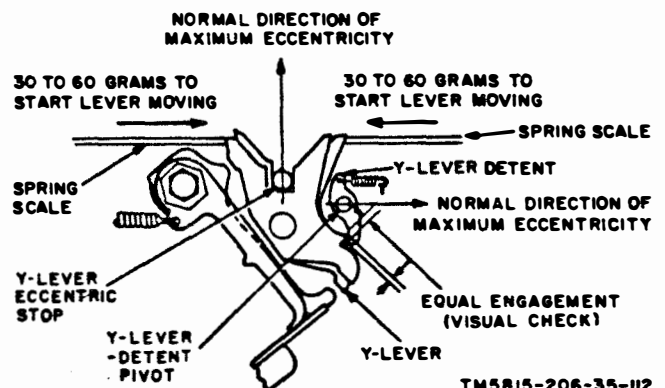
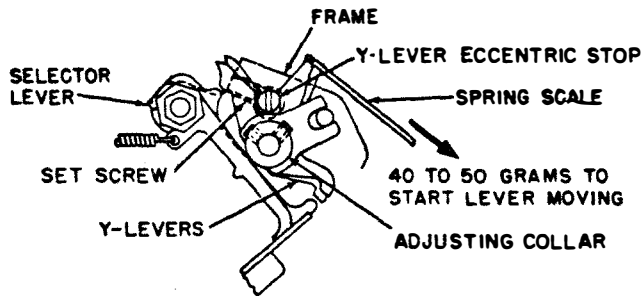

Figure 165. Y-lever detent and Y-lever adjustment (TT-4B/TG).

in figure 166, should be required to start each Y-lever moving from the counterclockwise to the clockwise position.

b. *Adjustment.* Loosen the two setscrews in the adjusting collar. Move the collar toward or away from the Y-levers until the requirement is met. Tighten the setscrews and recheck the requirement.



TM5815-206-35-113

Figure 166. Y-lever friction adjustment (TT-4A/TG).

174. Selector Friction-Clutch Adjustment (TT-4A/TG)

a. Requirements.

- (1) There should be 0.005- to 0.025-inch clearance between the clutch disk collar and the bearing of the selector-clutch fork (A, fig. 167).
- (2) A pull of 40 to 46 ounces, applied at the point shown in B, figure 167, should be required to hold the stop plate away from the stop lever when the motor is on.

b. Method of Checking.

- (1) Insert a flat feeler gage between the selector-clutch disk and the bearing of the selector-clutch fork to determine the clearance (a(1) above).
- (2) Hook the end of a spring scale on the stop-plate retainer of the selector camshaft. Turn the motor on; pull the spring scale until the stop plate moves away from the stop lever; and read the scale.

c. Adjustments.

- (1) Loosen the two setscrews in the collar of the clutch disk and position the clutch disk until requirement a(1) above is met. Tighten the two setscrews and recheck the clearance.
- (2) Loosen the two setscrews in the fric-

tion-adjusting collar and shift the collar in the proper direction until requirement a(2) above is met. Tighten the two setscrews and recheck the requirement.

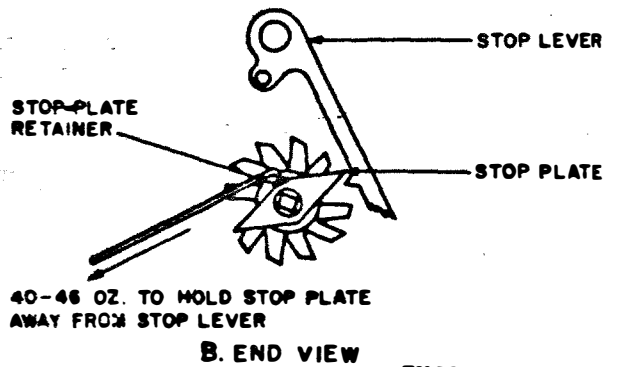
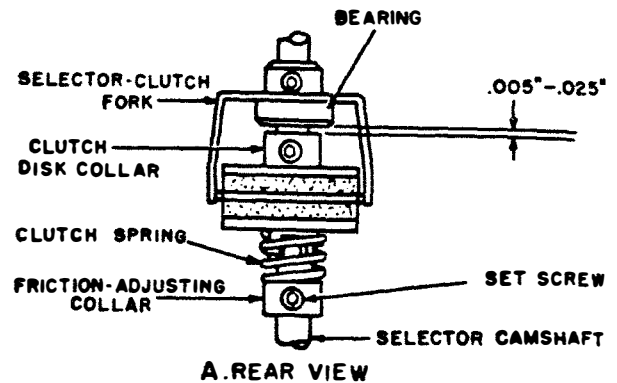

TM5815-206-35-114

Figure 167. Selector friction-clutch adjustment (TT-4A/TG).

175. Selector Friction-Clutch Adjustment (TT-4B/TG)

a. Requirements.

- (1) There should be .005- to .025-inch clearance between the collar of the clutch disk and the bearing of the selector-clutch fork (A, fig. 168).
- (2) A pull of 48 to 54 ounces, applied at the point shown in B, fig. 168, should be required to hold the stop plate away from the stop lever when the motor is on.

b. Method of Checking.

- (1) Insert a flat feeler gage between the friction clutch disk and the bearing of the selector-clutch fork to determine the clearance (a(1) above).

- (2) Hook the end of a spring scale on the stop-plate retainer of the selector cam-shaft. Turn the motor on; pull the spring scale until the stop plate moves away from the stop lever; and read the scale.

c. Adjustments.

- (1) Loosen the two setscrews in the collar of the clutch disk and position the clutch disk until requirement *a*(1) above is met. Tighten the setscrews, and recheck the clearance.
- (2) Loosen the clamping screws in the friction-adjusting collar and turn the friction-adjusting collar clockwise or counterclockwise to obtain requirement *a*(2) above. Tighten the clamping screws and recheck the requirement.

176. Rangefinder Shaft Adjustment

a. Requirements.

- (1) There should be 0.001- to 0.005-inch end play in the range-dial shaft,

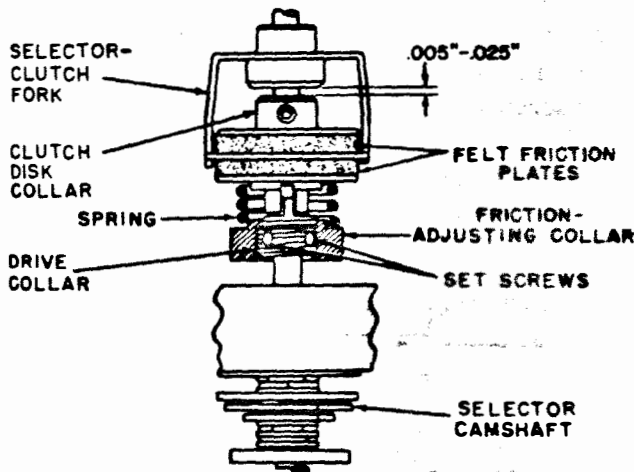

A. REAR VIEW

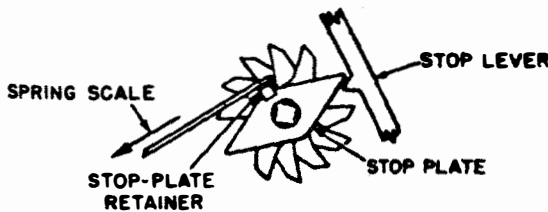

B. END VIEW

TM5815-206-35-115

Figure 168. Selector friction-clutch adjustment (TT-4B/TG).

rangefinder cam shaft, and the armature-worm shaft (A, fig. 169).

- (2) The RANGE dial should be set at 60 (B, fig. 169) when the *high* part of the rangefinder cam is against the lower arm of the orientation lever (A, fig. 170).

b. Adjustments.

- (1) Loosen the setscrews in the gears; position the gears to obtain the end play requirement; and tighten the set screws.
- (2) Loosen the setscrews in the armature worm; position the worm to meet the requirement; and tighten the setscrews.
- (3) Position the RANGE dial at 60. Loosen the setscrews in the rangefinder cam; position the cam to meet the requirement; and tighten the setscrews.

177. Orientation Lever Adjustment

(TT-4B/TG)

a. Requirement. There should be a $\frac{1}{64}$ - to $\frac{1}{4}$ -inch clearance between the stop plate and the adjusting screw in the orientation lever when the lever is held against the midpoint of the rangefinder cam (A, fig. 170).

b. Adjustment. Loosen the locknut (B, fig. 170); hold the orientation lever against the rangefinder cam; turn the adjusting screw in or out to meet the requirement; and tighten the locknut.

178. Selector-Lever Adjustment

a. Requirement. There should be a 0.002- to 0.005-inch clearance between the flat washer and the first selector lever (A, fig. 171).

b. Adjustment. Loosen the setscrew (B, fig. 171) in the casting; slide the selector-lever pivot stud in or out to meet the requirement; and tighten the set screw.

179. Selector-Lever Comb Adjustment

a. Requirement. The selector levers and Y-levers should be aligned, and there should be no binding between the selector levers and the selector-lever comb (A, fig. 172).

b. Adjustment. Loosen the two mounting screws (B, fig. 172); position the selector-lever comb to meet requirement *a* above (be certain

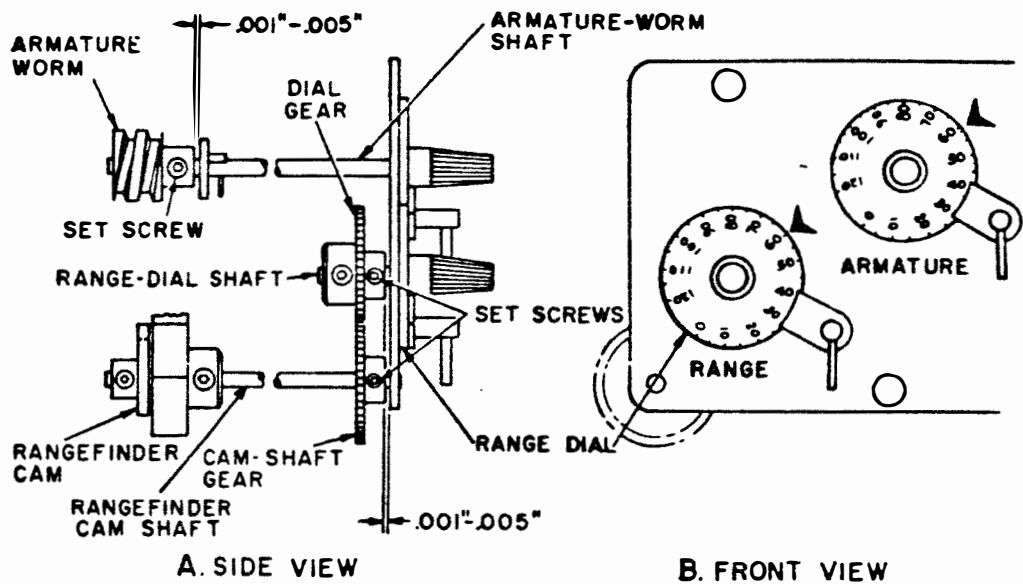

Figure 169. Rangefinder shaft adjustment.

that the comb is against the milled surface of the selector-lever-comb bracket); and tighten the mounting screws. Check the related adjustment (par. 186).

180. Selector-Magnet Armature Adjustment (TT-4A/TG) (fig. 173)

Note. The Y-lever eccentric stop preliminary adjustment (par. 165) should be completed before this adjustment is performed.

a. Requirement. There should be 0.002- to 0.005-inch clearance between the No. 1 Y-lever and the Y-lever eccentric stop when the No. 1 selector lever is in the marking position.

b. Method of Checking. Back off the upper armature stopscrew far enough to permit the selector levers to be engaged. Hold the arma-

ture against the upper stopscrew and rotate the selector camshaft until the No. 1 selector lever is on the highest part of its respective cam. Check the clearance requirement with feeler gages.

c. Adjustment. Loosen the pivot and mounting screws, and turn the mounting to the right or left until the requirement (a above) is met. Tighten the two screws.

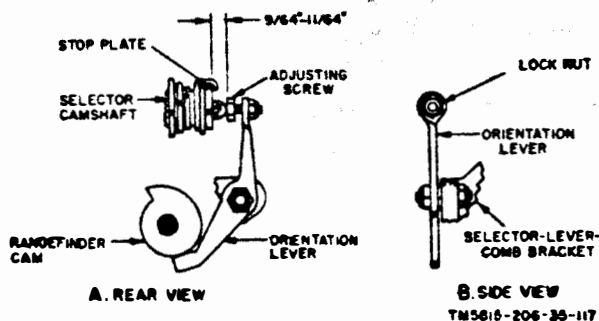

Figure 170. Orientation lever adjustment requirement (TT-4B/TG).

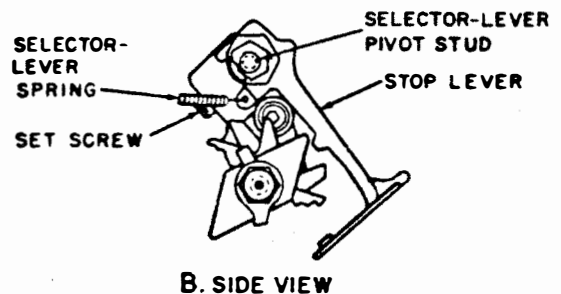
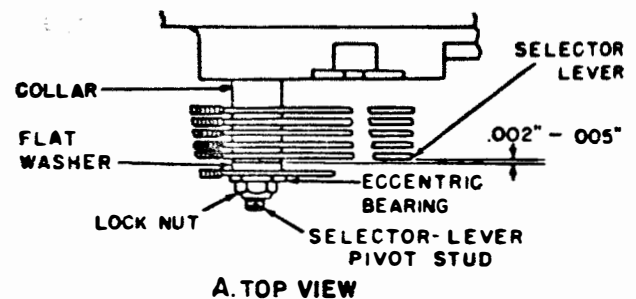

Figure 171. Selector-lever adjustment.

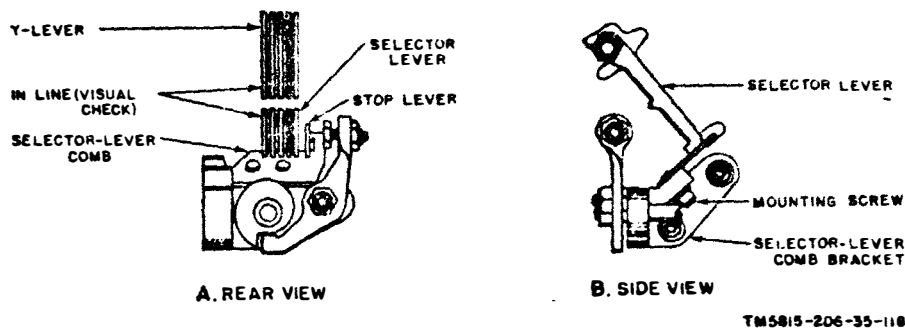

Figure 172. Selector-lever comb adjustment.

181. Selector-Magnet Armature Adjustment (TT-4B/TG) (fig. 174)

Note. The Y-lever eccentric stop preliminary adjustment (par. 165) should be completed before this adjustment is started.

a. Requirement. There should be 0.004- to 0.010-inch clearance between the No. 1 selector lever and the No. 1 Y-lever when the levers are positioned as follows:

- (1) No. 1 Y-lever positioned for mark against its eccentric stop.
- (2) No. 1 selector lever positioned for mark on the high part of its selector cam.

b. Method of Checking. Back off the upper armature stopscrew to permit the selector levers to engage the armature. Position the No. 1 Y-lever to *mark*. Hold the armature against the upper stopscrew and rotate the selector camshaft until the No. 1 selector lever is on the

highest part of the No. 1 selector cam. Check the clearance with a feeler gage.

c. Adjustment. With the teletypewriter conditioned as described in *b* above, loosen the pivot screw and the mounting screw. Turn the mounting to the right or left until the requirement (*a* above) is met. Tighten the two screws.

Note. When this adjustment is completed, all related adjustments in the sequence should be performed (par. 182 through 185).

182. Stoplever Adjustment (fig. 175)

a. Requirement. All five selector levers should clear the armature when the armature is dropped to permit the stoplever to clear.

b. Method of Checking. With the selector magnet energized, and the motor on, turn down the armature upper stopscrew to the point where the stoplever is released by the arma-

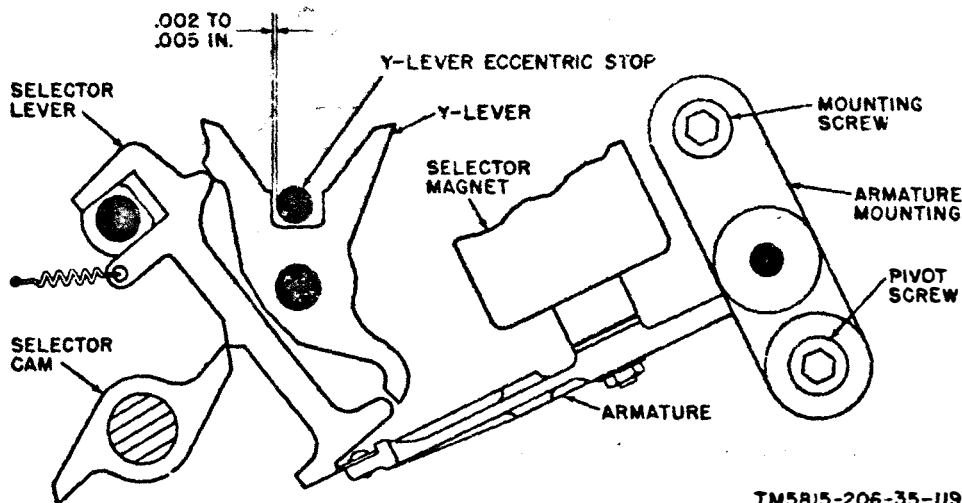

Figure 173. Selector-magnet armature adjustment (TT-4A/TG).

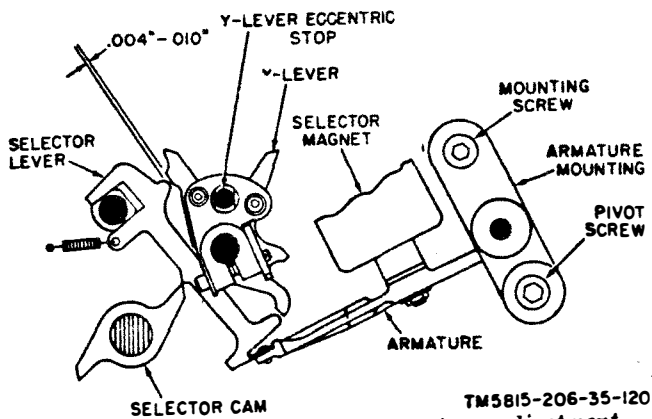

Figure 174. Selector-magnet armature adjustment (TT-4B/TG).

ture. All five selector levers should also be released at this point because all the Y-levers have been moved to the spacing (counterclockwise) position. Turn the upper stopscrew back to cause the armature to re-engage the stop lever. At least one of the five selector levers should also be engaged by the armature. Check this by trying to move the lower end of each selector lever.

c. Adjustment. Loosen the locknut and turn the stoplever (eccentric) pivot bearing in the direction shown.

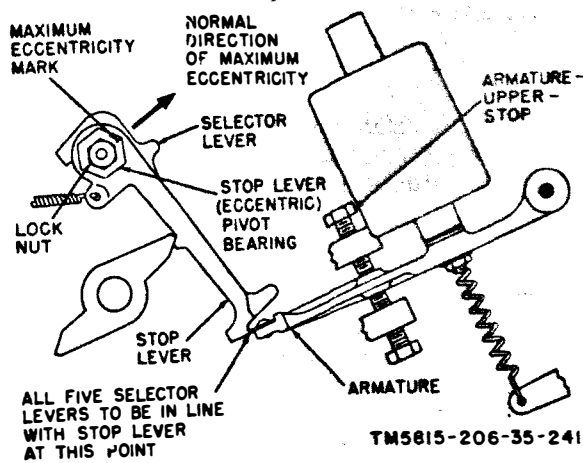

Figure 175. Stoplever adjustment.

183. Armature Upper-Stopscrew Adjustment (fig. 176)

Note. The stoplever adjustment (par. 182) should be completed before this adjustment is performed.

a. Requirement. The engagement of the armature with the selector levers when the armature is raised should be equal to the arma-

ture movement obtained from a one eighth turn of the armature upper-stop screw.

b. Adjustment. With the selector magnet energized and the motor on, turn down the upper-stop screw until the armature releases the stop and selector levers. Back off the upper-stop screw slowly until the armature makes contact with the stop and selector levers; continue to turn the screw $\frac{1}{8}$ turn. If all adjustments in the sequence are not being made, make the armature lower-stop screw adjustment (par. 184) and the selector magnet adjustment (par. 185).

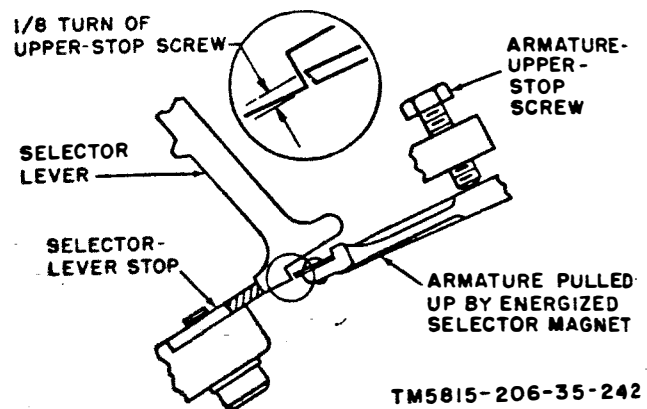

Figure 176. Armature upper-stop-screw adjustment.

184. Armature Lower-Stop Screw Adjustment (fig. 177)

Note. The armature upper-stop-screw adjustment (par. 183) should be completed before this adjustment is performed.

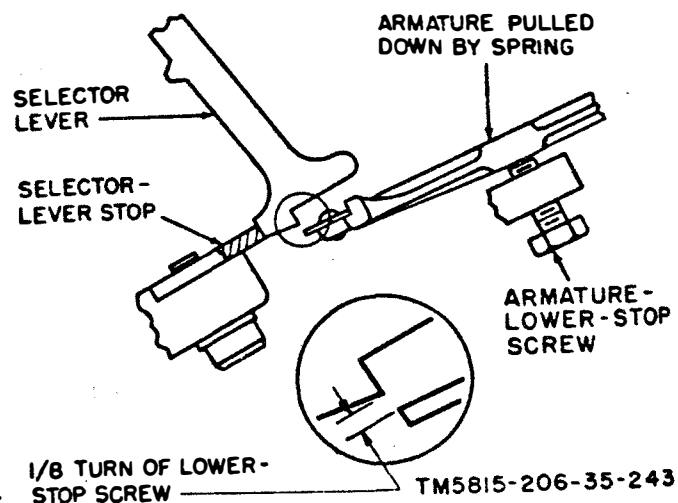

Figure 177. Armature lower-stop-screw adjustment.

a. *Requirement.* The clearance between the armature and the selector levers when the armature has been released should be equal to the armature movement obtained from a one eighth turn of the armature lower-stop screw.

b. *Adjustment.* Energize the selector magnet and start the motor. Turn the lower-stop screw until it contacts the armature. De-energize the selector magnet and turn the lower-stop screw down slowly until the armature does not engage the stop and selector levers. Continue to turn the screw one eighth turn.

185. Selector-Magnet Adjustments (fig. 178)

Note. The armature upper and lower stopscrew adjustments (par. 183 and 184) should be completed before this adjustment is attempted.

a. Requirements.

- (1) There should be 0.003- to 0.004-inch clearance between the pole faces of the selector magnet and the armature when the magnet is energized.
- (2) The clearance under the two pole faces should be equal.

b. Method of Checking.

- (1) Use a long narrow piece of 0.004-inch thick paper as a feeler to get the two pole faces.
- (2) The drag of the paper under both pole faces should be equal.

c. Adjustments.

- (1) Loosen the two mounting screws and shift the mounting up or down until the requirement (a above) is met. Tighten the two mounting screws. Check the requirements.
- (2) If the drag under the pole faces is

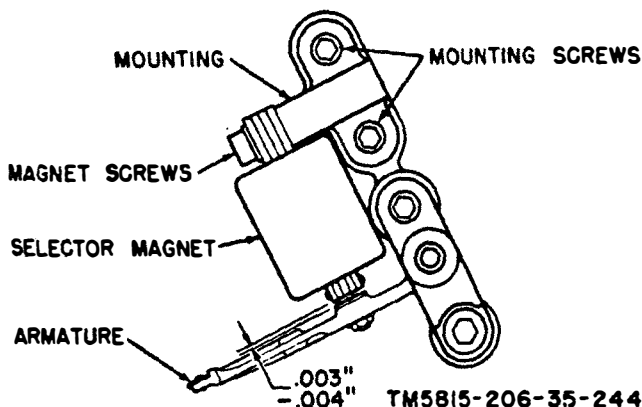

Figure 178. Selector-magnet adjustments.

not equal, remove the mounting with the magnet attached. Loosen the magnet screws and shift the position of the magnet, with regard to its mounting, in the direction needed for equalizing the clearance under the pole faces. Tighten the two magnet screws and replace the mounting. Repeat the adjustment for the required clearance. Repeat the above procedure until both requirements (a above) are met.

186. Selector-Magnet Armature and Selector-Lever Clearance Adjustment (fig. 179)

a. *Requirement.* There should be 0.018- to 0.025-inch clearance between the selector-magnet armature and the selector levers when the armature is in the *mark* (energized) position and the selector levers are at rest (unoperated) in the selector-lever comb.

b. *Method of Checking.* Place the teletypewriter in the stopped position (selector levers at rest) and the selector-magnet armature in the *mark* (energized) position, and check the requirement (a above). Use feeler gages.

c. *Adjustment.* Loosen the setscrews in the rangefinder cam and cam-shaft gear far enough to clear the grooves in the rangefinder-cam shaft. Remove the cam and slide the shaft towards the front of the teletypewriter until the rear end of the shaft is clear of the lower se-

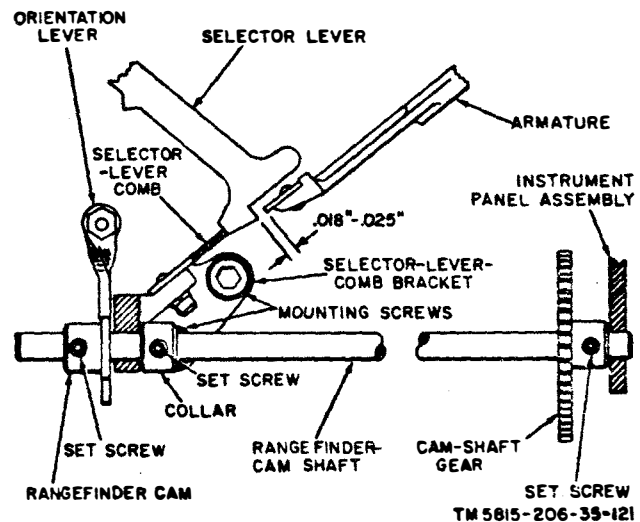

Figure 179. Selector-magnet armature and selector-lever clearance adjustment.

lector-lever-comb bracket mounting screw. Loosen the comb bracket mounting screws and position the bracket to meet the requirement (a above). Tighten the mounting screws and recheck the requirement. Replace the range-finder-cam shaft and remount the rangefinder cam.

Caution: When tightening the rangefinder cam and the cam-shaft gear on the shaft, the setscrews must engage the groove in the shaft. Align the rangefinder cam with the orientation lever and tighten the setscrews. Engage the cam-shaft gear with its associated gear and tighten the setscrews on the cam-shaft gear.

187. Function Punch-Bar and Side-Plate Adjustment (fig. 180)

Note. This adjustment should be performed when either the punch-bar-guide block or the side plate have been disassembled.

a. Requirement. There should be 0.001- to 0.008-inch clearance between the punch bars and the aperture gate when the aperture gate is aligned with each punch bar.

b. Method of Checking. Align the aperture gate with the punch bars and check the requirement with feeler gages.

c. Adjustment. Loosen the side plate mounting screws. Position the side plate to meet the requirement (a above), and tighten the mounting screws. Recheck the requirement.

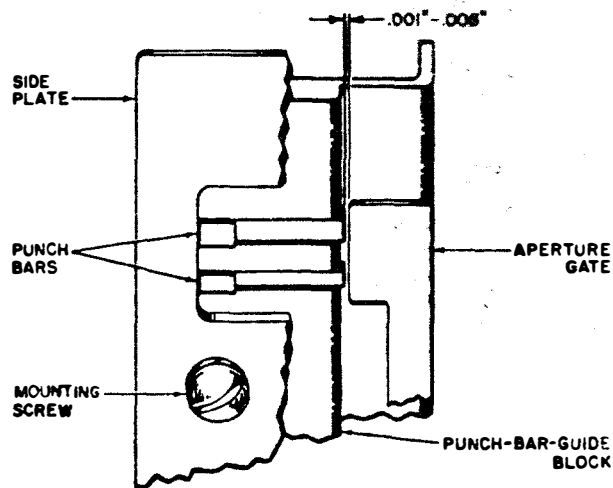

Figure 180. Function punch-bar and side-plate adjustment.

TM5815-206-35-122

188. Function-Lever-Bracket Adjustment (fig. 181)

a. Requirements.

- (1) The upper end of the function-cam follower should be centered in the groove of the function-selecting arm.
- (2) The roller on the lower end of the function-cam follower should be engaged in the groove of the function cam. The engagement should be at least 75% of the width of the roller and the roller must *not* be in contact with the bottom of the groove.
- (3) The letters-shift lever must engage the letters-shift punch bar and the lever must be free to move without bind.

b. Adjustment. Loosen the two bracket-mounting screws (accessible from the inner side of the casting). Position the bracket to meet all three requirements and tighten the mounting screws.

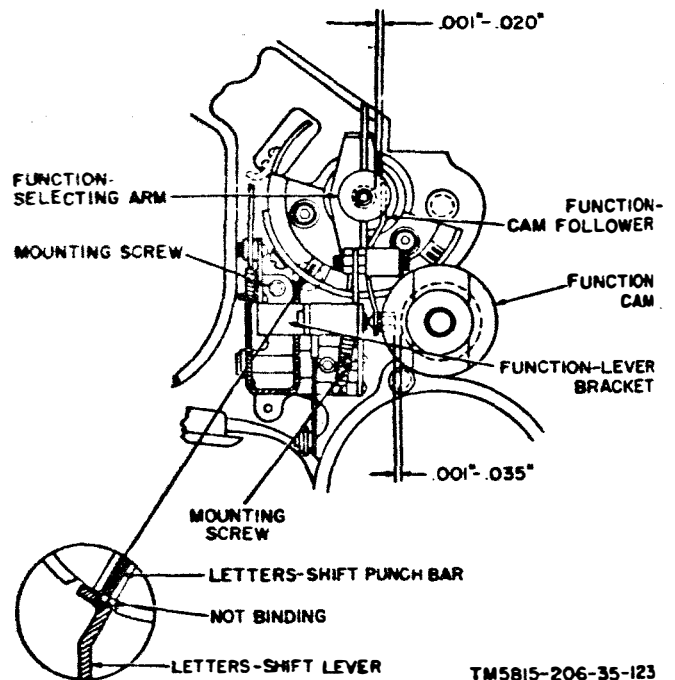

TM5815-206-35-123

Figure 181. Function-lever-bracket adjustment.

189. Letters-Shift-Lever Shaft End-Play Adjustment (fig. 182)

a. Requirement. The letters-shift lever and the platen latch should be in visual alinement. The carriage-feed lever and the function-cam

follower should be in alignment. There should be clearance up to a maximum of .005 inch between the collar and the carriage-feed lever.

b. *Adjustment.* Hold the letters-shift-lever shaft against the bracket and loosen the setscrews in the collar. Position the collar to meet the requirement (a above) and tighten the setscrews.

Note. The letters-shift lever must be held parallel to the bracket while the adjustment is being performed and the requirement is being measured.

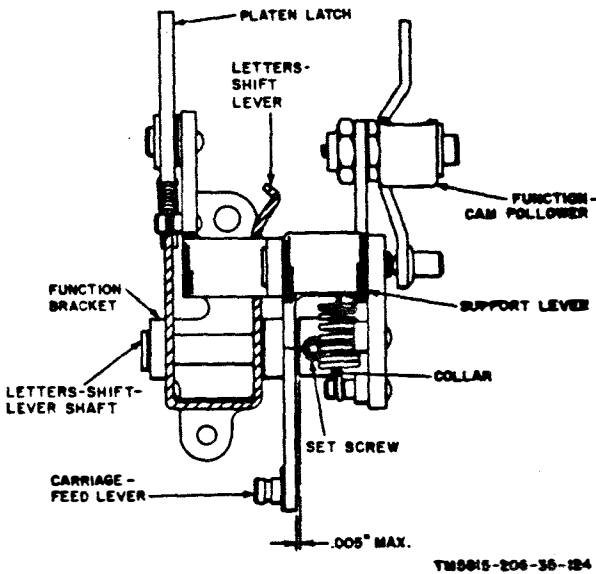

Figure 182. Letters-shift-lever shaft end-play adjustment.

190. Function-Clutch Tension Adjustment (TT-4A/TG) (fig. 183)

a. *Requirement.* There should be a clearance of 0.080- to 0.100-inch between the flexible-coupling disk and the function-clutch drum when the clutch drum is engaged with the function-shaft driven gear.

b. *Method of Checking.* Trip the transfer-lever latch and turn the motor by hand until the function-clutch drum has engaged the function-shaft driven gear. Insert a flat feeler gage through the clutch spring and between the flexible-coupling disk and the function-clutch drum to determine the clearance.

c. *Adjustment.* Loosen the two setscrews in the flexible-coupling disk and shift the disk in the proper direction to obtain the required clearance. Tighten the two setscrews.

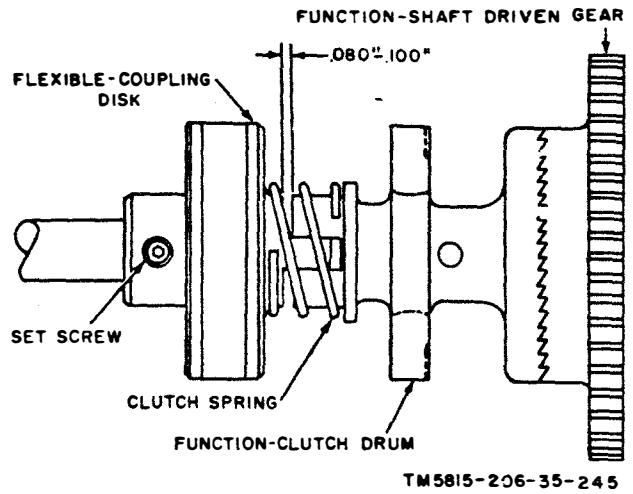

Figure 183. Function-clutch tension adjustment (TT-4A/TG).

191. Function-Shaft Flexible-Coupling Disk Adjustment (TT-4B/TG) (fig. 184)

Note. The function clutch clearance adjustment (par. 168) should be completed before performing this adjustment.

a. *Requirement.* There should be a clearance of 0.010- to 0.040-inch between the flexible-coupling disk and the function-clutch drum when the teletypewriter is in the stopped position and the drum is disengaged from the function-shaft driven gear.

b. *Method of Checking.* When the teletypewriter is in the stopped position, the function-

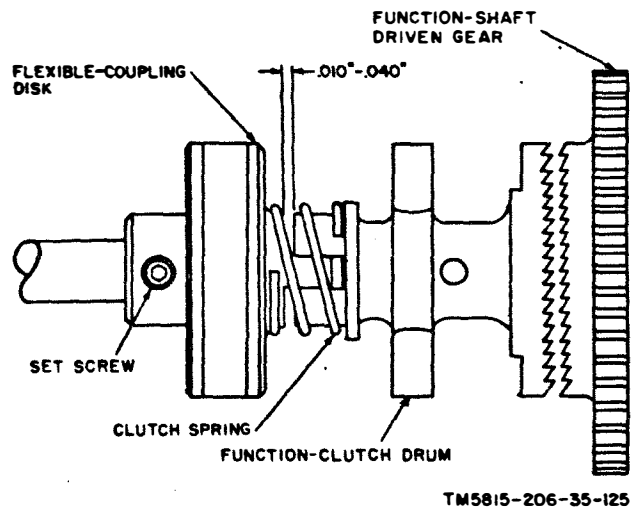

Figure 184. Function-shaft flexible coupling disk adjustment (TT-4B/TG).

clutch drum should be disengaged from the function-shaft driven gear. Insert feeler gages through the clutch spring to check the requirement.

c. Adjustment. Loosen the two setscrews in the flexible coupling disk and shift the flexible-coupling disk in the proper direction to obtain the required clearance. Tighten the two setscrews. Check related adjustment (par. 192).

192. Adjustment of Angular Relationship of Function-Shaft Parts (TT-4B/TG)

a. Requirements.

- (1) When an arm of the function-clutch drum is fully engaging the function-clutch latch (fig. 161), the locking-bail cam follower (fig. 151) should be at the high point of the locking-bail cam (fig. 185).
- (2) When an arm of the function-clutch drum is fully engaging the function-clutch latch, the roller of the print-cam follower (fig. 219) should be in the low part of the print cam (fig. 185).
- (3) Immediately after the transfer operation has occurred and the function-clutch drum has engaged the function-shaft driven gear (fig. 183) the function sensing levers (fig. 146) should fall to the low point of their associated cams within $\frac{1}{3}$ to $\frac{2}{3}$ revolution of the motor.
- (4) When an arm of the function-clutch drum is fully engaging the function-clutch latch, the roller on the function-cam follower (fig. 186) should be just beyond a high point of the function cam (fig. 185).

b. Method of Checking.

- (1) Turn off the motor. Manually rotate the function shaft to be sure that an arm of the function-clutch drum has fully engaged the function-clutch latch. Visually check the requirement (a(1) above).

Note. Be sure that the requirement is met before proceeding with the remaining adjustment checks.

- (2) Turn the motor on. Depress any key-lever. When the operation is complete, turn the motor off. Manually attempt to rotate the function shaft in its

normal direction; there should be no movement. Trip the transfer-lever latch (fig. 158) and manually rotate the motor. Observe the print bail blade to be sure that there is no backward movement before the blade starts its forward travel.

- (3) Turn off the motor. Manually rotate the function shaft to be sure that an arm of the function-clutch drum has fully engaged the function-clutch latch. Position the Y-levers for the line-feed code combination and trip the transfer-lever latch. Slowly rotate the motor by hand until the function-clutch drum has engaged the function-shaft driven gear and note the position of a target spot on the motor. Rotate the motor $\frac{1}{3}$ to $\frac{2}{3}$ revolution more while checking to make certain that the line-feed sensing lever is pulled to the low part of its cam during this operation.
- (4) Manually rotate the function shaft to make certain that an arm of the function-clutch drum fully engages the function-clutch latch. Trip the transfer-lever latch and rotate the motor by hand. Observe the function-selecting arm to be sure that there is no outward movement before the function-selecting (fig. 186) arm starts its inward thrust.

c. Adjustments.

Note. When securing parts of the function shaft, be sure that all setscrews are tightened against the flats of the shaft.

- (1) Loosen the setscrews in the flexible-coupling disk. Hold the function-clutch drum firmly against the function-clutch latch and rotate the function shaft to meet the requirement (a(1) above). Tighten the setscrews, and then perform the adjustments listed in (2), (3), and (4) below.
- (2) Loosen the setscrews in the print cam. While holding an arm of the function-clutch drum in firm engagement with the function-clutch latch, rotate the print cam to the point where any backward rotation of the print cam starts to move the print-

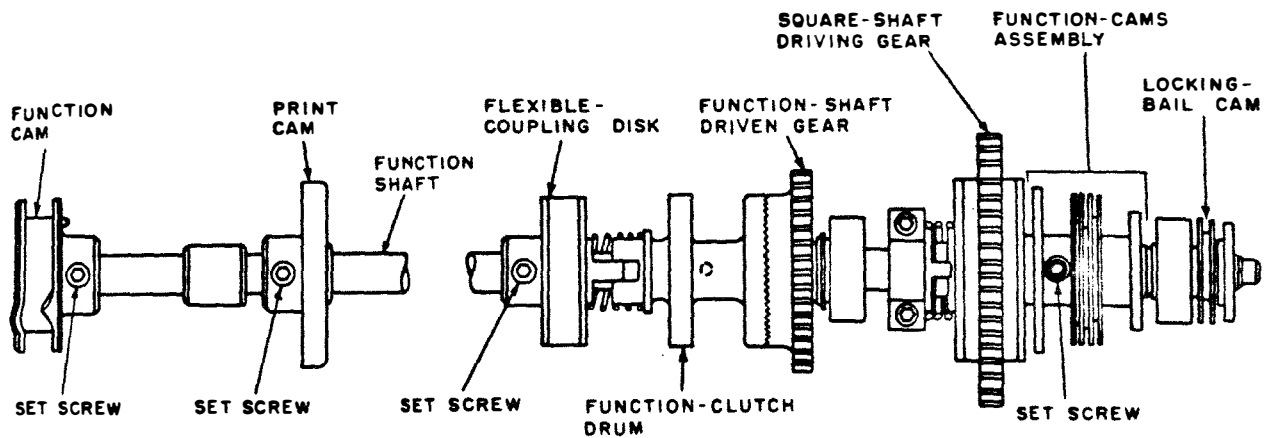

TM5815-206-35-195

Figure 185. Location of parts on function shaft (TT-4B/TG).

- cam follower. Tighten the setscrews.
- (3) Loosen the setscrews in the function-cams assembly and rotate it (fig. 185) to meet the requirement (a(3) above). Tighten the setscrews.
 - (4) Loosen the setscrews in the function (fig. 185) cam and rotate the cam to meet the requirement (a(4) above). Tighten the setscrews.

193. Function-Cam Adjustment (fig. 186)

a. Requirement. There should be 0.008- to 0.020-inch clearance between the function-selecting arm and the punch-bar-guide block when the function-selecting arm is in its unoperated position.

Note. If a punch bar protrudes beyond the punch-bar-guide block, there should be 0.002-inch minimum clearance between the punch bar and the function-selecting arm, but the maximum tolerance given in the requirement (a above) should not be exceeded.

b. Method of Checking. Check visually to determine if a punch bar (or bars) protrudes beyond the punch-bar-guide block. If this condition exists, depress the keylever to align the function-selecting arm with that punch bar. Check for the 0.002-inch minimum clearance between the function-selecting arm and punch-bar and the 0.008- to 0.020-inch clearance between the function-selecting arm and the punch-bar-guide block. If no punch bar protrudes beyond the punch-bar-guide block, align the function-selecting arm with any portion of the punch-bar-guide block and check

the requirement (a above) with feeler gages. Check both sides of the function-selecting arm.

c. Adjustment. Loosen the setscrew in the function cam. Move the function cam in the proper direction along the function shaft until the requirement is met. Tighten the setscrews and recheck the requirement and the related adjustment (par. 192).

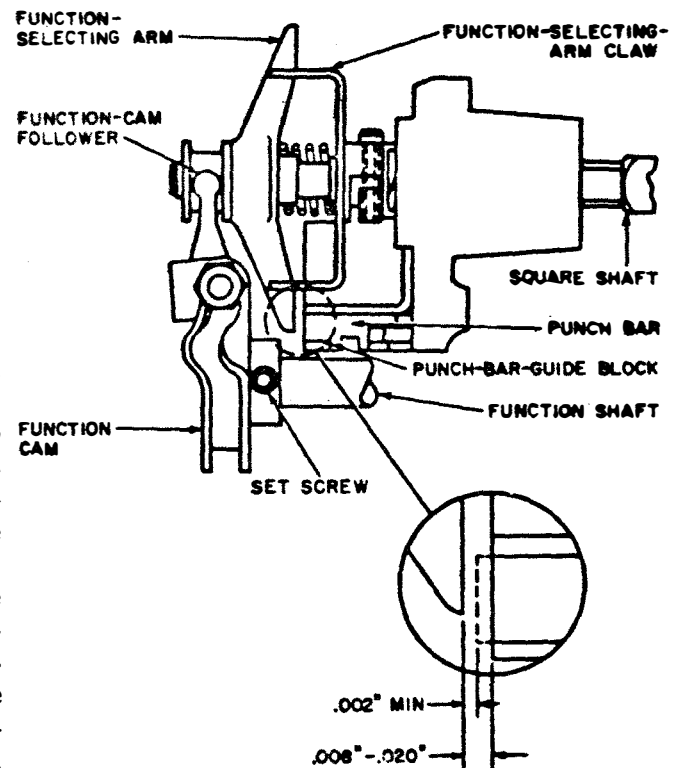

TM5815-206-35-126

Figure 186. Function-cam adjustment.

194. Carriage-Feed Ratchet Adjustment (fig. 187)

a. Requirement. There should be 0.010- to 0.020-inch clearance between the carriage-feed ratchet and the end of the flat on the carriage-feed shaft.

b. Adjustment. Loosen the setscrews on the ratchet and position it to meet the requirement (*a* above). Tighten the setscrews.

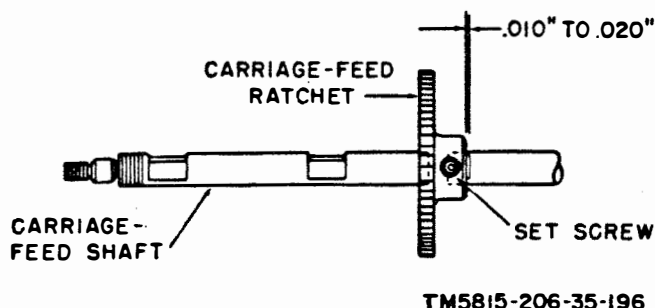

Figure 187. Carriage-feed ratchet adjustment.

195. Carriage-Feed-Shaft Drive-Collar Adjustment (TT-4B/TG) (fig. 188)

a. Requirement. The friction-clutch assembly should be compressed against the carriage-feed ratchet with a 1- to 1½-pound pressure.

b. Adjustment. Loosen the setscrews in the drive collar; apply a 1½-pound pressure on the end of the carriage-feed shaft and against the drive collar; and tighten the setscrews.

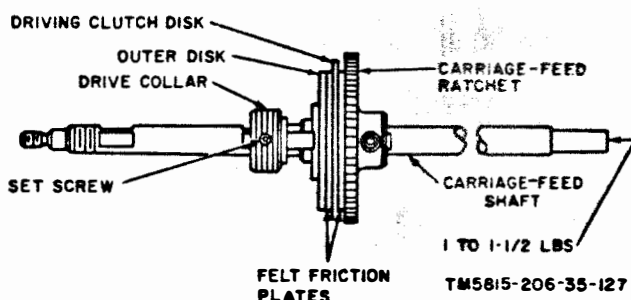

Figure 188. Carriage-feed-shaft drive-collar adjustment (TT-4B/TG).

196. Carriage-Feed Driving Gear End-Play Adjustment (fig. 189)

a. Requirement. There should be a 0.001- to 0.005-inch clearance between the flat washer and the shoulder on the carriage-feed shaft, when the carriage-feed driving gear is held tightly against the ball bearing.

b. Method of Checking. Push the carriage-feed-clutch drum and the carriage-feed driving gear apart and check the clearance with a feeler gage.

c. Adjustment. Loosen the self-locking hexagonal nut on the end of the carriage-feed shaft. Rotate the adjusting nut in proper direction until the requirement (*a* above) is met. Tighten the self-locking hexagonal nut and recheck the clearance.

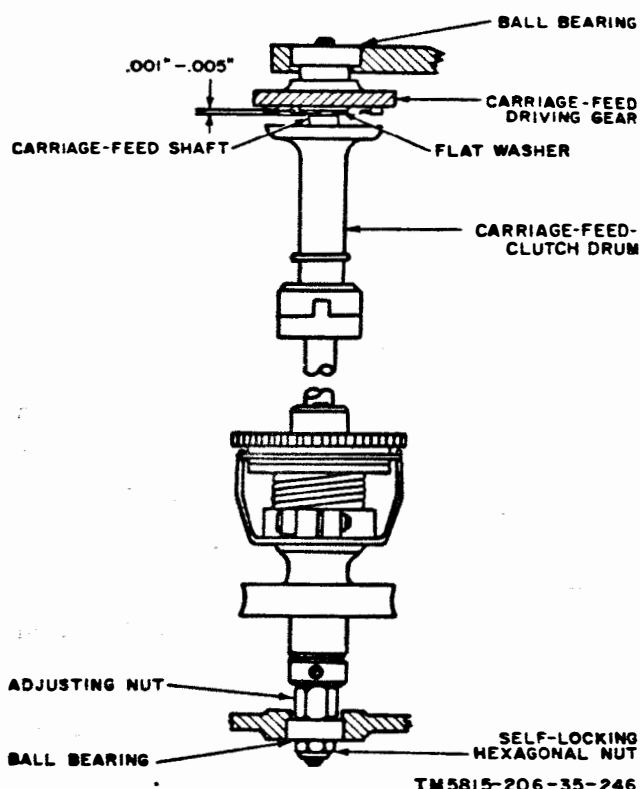

Figure 189. Carriage-feed driving gear end-play adjustment.

197. Carriage-Feed Driven Gear Adjustment (fig. 190)

a. Requirement. The carriage-feed driven gear should be centered with the carriage-feed worm on the main shaft.

b. Adjustment. Loosen the setscrews in the shaft collar. Push the carriage-feed driven gear forward until tight. Measure distance Y as shown. Pull the carriage-feed driven gear rearward until tight and measure distance X as shown. Divide the difference between the two measurements and add to X. Using this dimension, position the carriage-feed driven

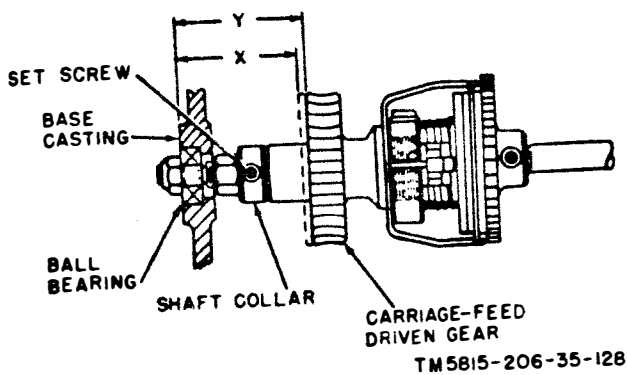

Figure 190. Carriage-feed driven gear adjustment.

gear, slide the shaft collar against the gear, and tighten the setscrews in the collar

198. Carriage-Feed Pawl Adjustment (fig. 191)

a. Requirement. There should be a 0.005- to 0.015-inch clearance between the carriage-feed pawl and the carriage-feed blocking lever when—

- (1) The carriage is in the 72d space from the left margin.
- (2) The platen is in the letters-shift position and the S or H code group is set up on the code rings.
- (3) The carriage-feed pawl is fully operated.

b. Adjustment. Detach the adjusting link from the carriage-feed pawl and turn the link 1 or more half-turns as necessary to meet the requirement (a above). Attach the link to the pawl and recheck the requirement.

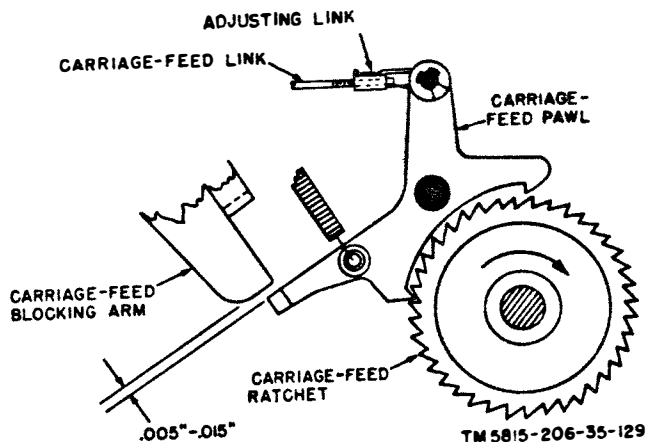

Figure 191. Carriage-feed pawl adjustment.

199. Carriage-Return Clutch-Lever-Shaft Clearance Adjustment (TT-4B/TG) (fig. 192)

a. Requirements.

- (1) There should be 0.002- to 0.005-inch clearance between the carriage-return clutch-actuating lever and the clutch-latch mounting plate.
- (2) There should be 0.002- to 0.005-inch clearance between the throw-out lever and the double-blocking lever.

b. Adjustments.

- (1) Loosen the clamping screw on the carriage-return clutch-actuating lever. Loosen the setscrews on the carriage-return clutch-lever shaft collar. Insert a flat feeler gage between the carriage-return clutch-actuating lever and the clutch-latch mounting plate. Press the top on the shaft and, while the feeler gage is held between the carriage-return clutch-actuating lever and the clutch-latch mounting plate, tighten the setscrews in the shaft collar. Make the carriage-return clutch-actuating lever adjustment (par. 200) before tightening the clamping screw in the carriage-return clutch-actuating lever.
- (2) Loosen the clamping screw in the throw-out lever. Insert a flat feeler gage between the throw-out lever and the double-blocking lever and tighten the clamping screw.

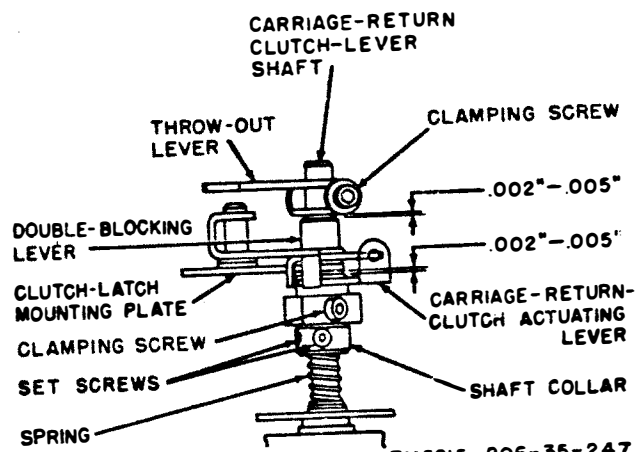

Figure 192. Carriage-return clutch-lever-shaft clearance adjustment (TT-4B/TG).

200. Carriage-Return Clutch-Actuating-Lever Adjustment (TT-4B/TG)

(fig. 193)

a. Requirement. When the carriage is two or more spaces from the left hand margin and the carriage-return-clutch members are fully engaged, there should be some, but not more than 0.005-inch clearance between the carriage-return clutch-actuating lever and the carriage-return latch.

b. Method of Checking. When the carriage is two or more spaces from the left hand margin and the motor is off, select the carriage-return operation. Release the transfer lever and turn the motor by hand until the carriage-return clutch is fully engaged. Manually hold the carriage-return-clutch lever (fig. 195) in a counterclockwise direction and check clearance with a feeler gage.

c. Adjustment. Disconnect the carriage-feed clutch-lever spring (fig. 195) and the horizontal carriage-return link (fig. 210). Manually hold the carriage-return-clutch members in full engagement. Loosen the clamping screw fig. 193 and rotate the carriage-return clutch-actuating lever to meet the requirement (*a* above). Hold the carriage-return clutch-actuating lever down against the shaft collar and tighten the clamping screw. Reconnect the carriage-feed clutch-lever spring and make the carriage-return clutch adjustment (par. 201). Check the related adjustments (par. 214, 215, and 250).

201. Carriage-Return Clutch Adjustment (TT-4B/TG)

(fig. 194)

a. Requirements. The carriage-return clutch

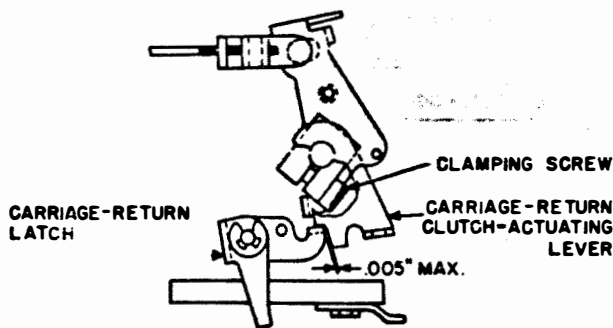

TM5815-206-35-132

Figure 193. Carriage-return clutch-actuating-lever adjustment (TT-4B/TG).

should be fully engaged before the carriage-return sensing lever strikes the lowest portion of the restoring cam, and the carriage-feed clutch should not bounce when characters other than carriage return are selected.

b. Method of Checking. Depress the space bar and the repeat keylever. While the carriage is moving to the right, watch the carriage-feed clutch. The clutch should remain fully closed while the carriage is moving. When the carriage is one or more spaces from the left hand margin, turn off the motor. Select any keylever except the carriage return, trip the transfer-lever latch and turn the motor by hand until the carriage-return sensing lever touches the carriage-return stop bar. The double-blocking lever should be rotated to the point where it just contacts the carriage-return-clutch actuating lever.

c. Adjustment. Select any character except the carriage return. Trip the transfer-lever latch and rotate the motor by hand until the carriage-return sensing lever touches the carriage-return stop bar. Detach and adjust the horizontal carriage-return link so that when it is fitted over the stud on the carriage-return-

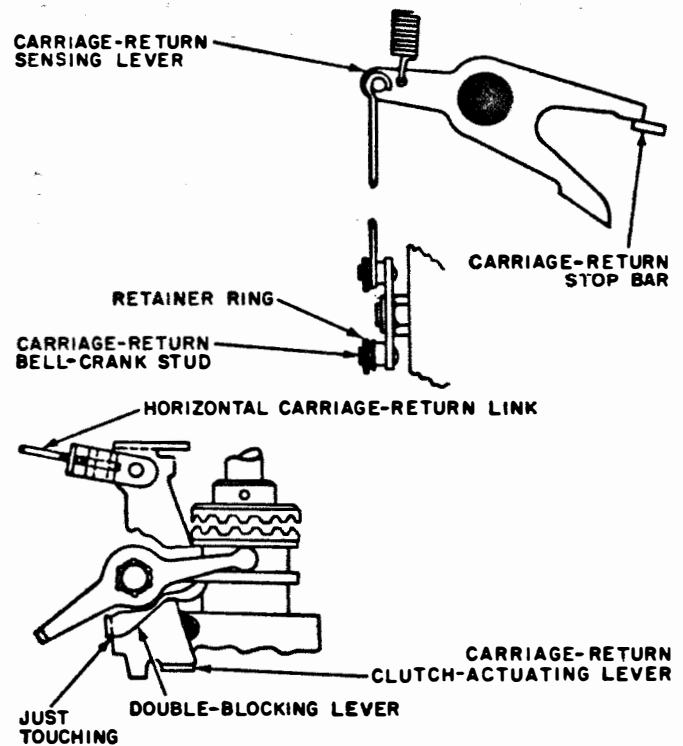

TM5815-206-35-168

Figure 194. Carriage-return clutch adjustment (TT-4B/TG).

bell crank, the double-blocking lever is just touching the carriage-return-clutch actuating lever.

202. Carriage-Feed-Clutch Drum Adjustment (fig. 195)

a. Requirement. With the members of the carriage-return clutch engaged, there should be 0.035- to 0.045-inch clearance between the carriage-feed-clutch drum and the carriage-feed driving gear.

b. Method of Checking. With the carriage one or more spaces from the left hand margin, turn off the motor. Select the carriage return, release the transfer lever, and turn the motor by hand until the carriage-return clutch is fully engaged. Check for the requirement (a above).

c. Adjustment. Loosen the setscrew and turn the carriage-feed-clutch-lever stud until the requirement (a above) is met. Tighten the setscrew.

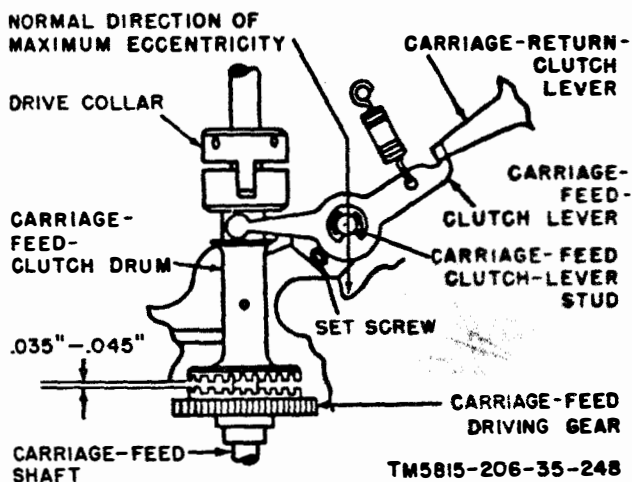

Figure 195. Carriage-feed-clutch drum adjustment.

203. Decelerating Cam and Carriage-Feed Clutch Positioning Adjustment (TT-4B/TG)

a. Requirement. With the carriage at the left hand margin, the finger of the decelerating cam should be centered (plus or minus $\frac{1}{16}$ inch) with the adjacent hole in the carriage-return driven gear (B, fig. 196).

b. Method of Checking. Return the carriage to the left hand margin and check the finger position visually.

c. Adjustment. Make the adjustment in the following steps:

- (1) Loosen the mounting screws (A, fig. 200) far enough to disengage the carriage rack from the carriage-rack driving gear. Move the carriage to the right hand margin.
- (2) Loosen the clamping screws (B, fig. 196) and rotate the carriage-return latch-tripping arm as far clockwise as possible.
- (3) Loosen one of the two setscrews that hold the drive collar (fig. 195) to the carriage-feed shaft and turn the shaft until the other setscrew in the collar is straight up. Remove the double-

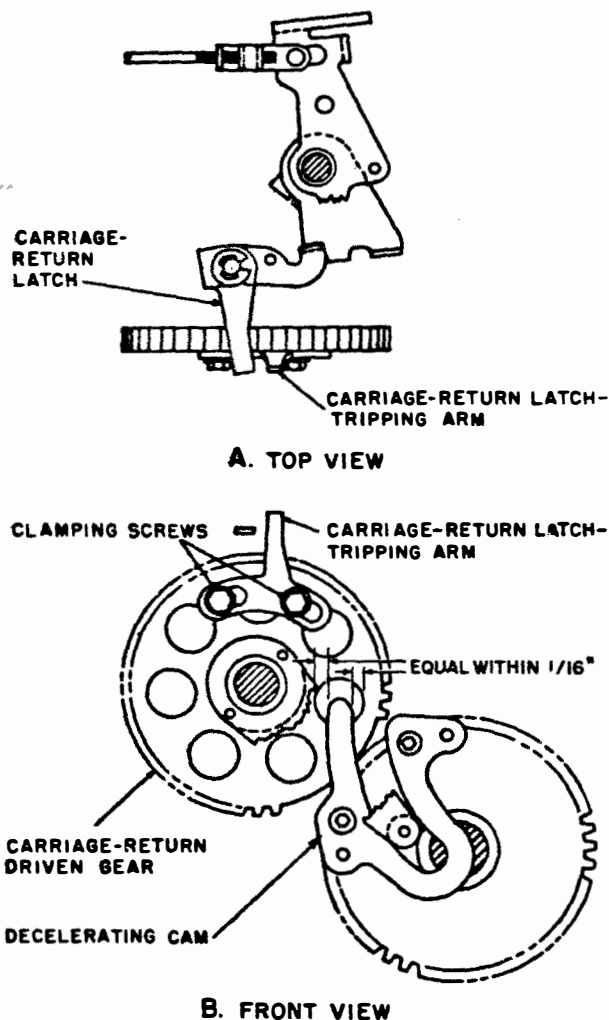

Figure 196. Decelerating cam and carriage-feed-clutch positioning adjustment (TT-4B/TG).

blocking lever spring (A, fig. 197) and manually disengage the carriage-feed clutch (fig. 195). Rotate the carriage-rack driving gear (A, fig. 200) until the decelerating cam (B, fig. 196) is set as closely as possible to the position described in *a* above. Engage the carriage-feed clutch and replace the double-blocking lever spring.

- (4) Loosen the other setscrew in the drive collar on the carriage-feed shaft turn the carriage-feed ratchet until a tooth of the ratchet presses firmly against the upper latching arm of the carriage-feed pawl (fig. 191). Rotate the drive collar until the cam is positioned within the requirement (*a* above) and tighten both setscrews. Make the carriage-return latch-tripping arm adjustment (par. 204). Then make the related adjustments (par. 206 and 208).

Note. The above adjustment can most easily be made when the motor is operating. Extreme care should be exercised to prevent injury.

204. Carriage-Return Latch-Tripping-Arm Adjustment (TT-4B/TG) (fig. 197)

a. Requirement. The carriage-return latch-tripping arm should trip the carriage-return latch when the decelerating cam reaches the position shown in B, figure 196 and the carriage-feed clutch members (fig. 195) are aligned to mesh.

b. Method of Checking. Move the carriage 10 or more spaces from the left-hand margin and turn the motor off. Press the CAR RET keylever and turn the motor by hand until the carriage nears the left-hand margin. When the carriage-return latch-tripping arm touches the carriage-return latch (A, fig. 197), turn the motor slowly. Watch the alinement of the carriage-feed-clutch teeth and the position of the decelerating cam at the time of disengagement.

c. Adjustment. Loosen the clamping screw in the throw-out lever (fig. 208). Position the decelerating cam and the carriage-feed clutch (fig. 196). Loosen the two clamping screws (B, fig. 197) and position the carriage-return latch-

tripping arm flush with the carriage-return latch when the latch is flush with the carriage-return clutch-actuating lever (A, fig. 197). Tighten one of the clamping screws and recheck the requirement (*a* above). If the carriage-return latch is tripped too soon, position the latch-tripping arm clockwise. If the latch is tripped too late, position the latch-tripping arm counterclockwise. Tighten both clamping screws. Perform the related adjustment (par. 215).

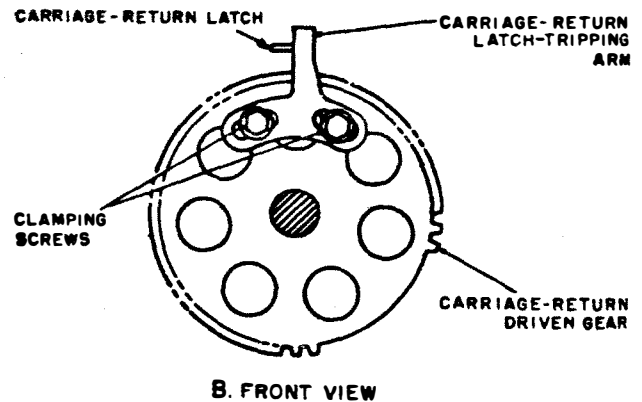
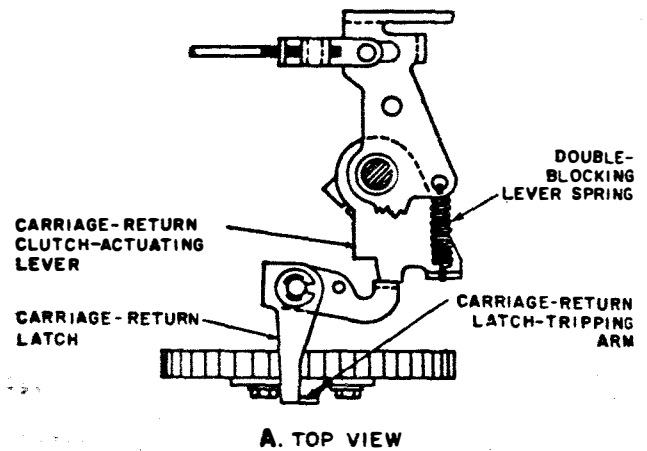

TM5815-206-35-250

Figure 197. Carriage-return latch-tripping-arm adjustment (TT-4B/TG).

205. Square-Shaft Sliding-Gear Bearing Adjustment (fig. 198)

Note. This adjustment should be performed during installation of the carriage on the teletypewriter.

a. Requirement. The flat portion of the square-shaft sliding-gear bearing should be positioned downward and towards the rear to

provide clearance for the function-shaft driven gear.

b. Method of Checking. Check the requirement visually.

c. Adjustment. When installing the type-bar carriage, the rear support fork of the carriage frame should engage the square-shaft sliding-gear bearing so that the flat side of the bearing is towards the function-shaft driven gear.

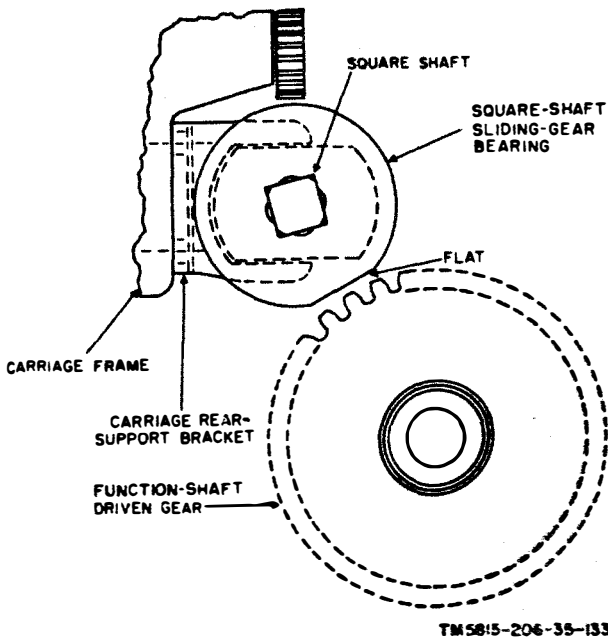

Figure 198. Square-shaft sliding-gear bearing adjustment.

206. Carriage Position Adjustment (fig. 199)

a. Requirement. There should be a $2\frac{3}{8}$ - to $2\frac{1}{2}$ -inch clearance between the rear side of the code-ring-cage plate and the center line of the carriage when the carriage is at the left-hand margin and the decelerating cam is positioned as shown in figure 196.

b. Adjustment. Position the carriage at the left hand margin. Loosen the locknut and back the left-margin stopscrew away from the carriage frame. Loosen the carriage-rack mounting screws to disengage the rack from the carriage-rack driving gear (fig. 200). Position the carriage and reengage the rack with the gear. Tighten the locknut. Check related adjustment (par. 207).

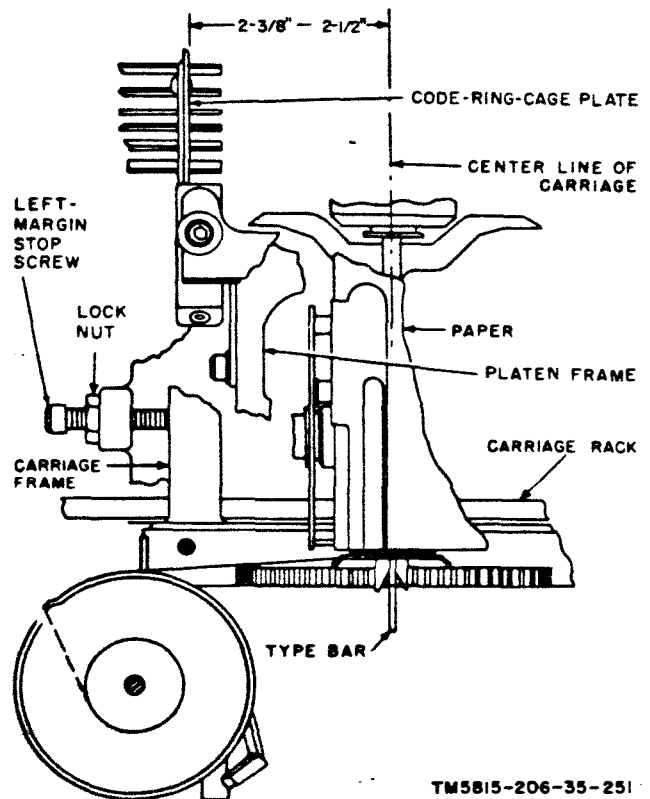

Figure 199. Carriage position adjustment.

207. Ball Bearing Adjustment

a. Requirement. The carriage should roll from one end of the guide rail to the other with no clearance between the ball bearing and the guide rail (B, fig. 200).

b. Adjustment. Remove the carriage rack (A, fig. 200). Loosen the setscrew that holds the roller mounting stud of the ball bearing; turn the stud until the requirement (a above) is met; and tighten the setscrew. Replace and adjust the carriage rack as described in paragraph 208.

208. Carriage-Rack Adjustment (fig. 201)

a. Requirement. There should be minimum backlash between the carriage-rack driving gear and the carriage rack.

b. Adjustment. Move the carriage to the left-hand margin. Loosen the two carriage-rack mounting screws and position the carriage rack for minimum backlash. Tighten the screw that is nearer the carriage-rack driving gear. Move the carriage to the right hand margin. Position the carriage rack for minimum backlash and

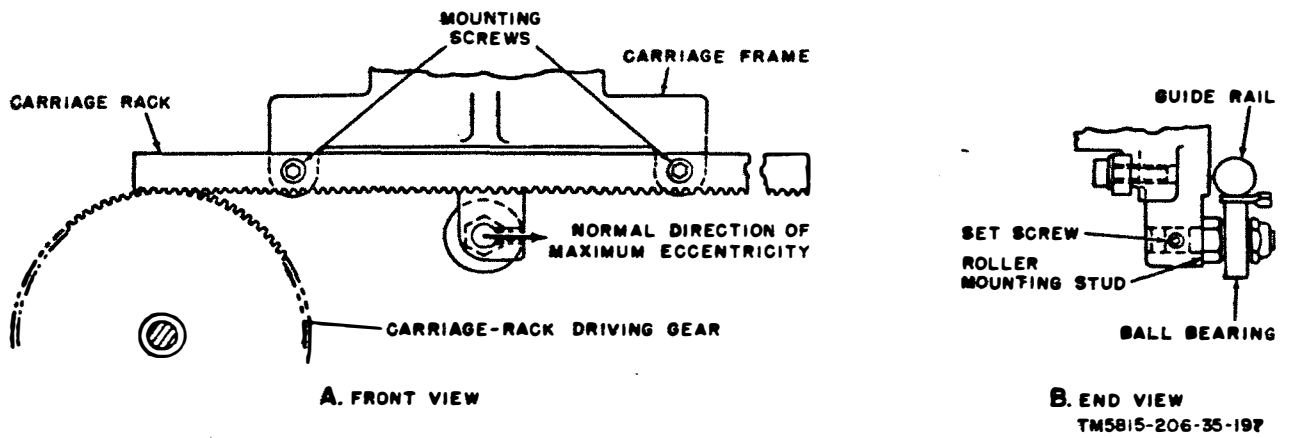

Figure 200. Ball bearing adjustment.

tighten the second screw. There should be equal and minimum backlash on both ends of the carriage rack.

209. Carriage-Rack Drive-Shaft Adjustment (fig. 202)

a. *Requirement.* There should be some clearance but not more than 0.010-inch clearance between the collar and the ball bearing when the shoulder of the carriage-rack drive shaft is tight against the ball bearing.

b. *Method of Checking.* Push and pull the carriage-rack drive shaft lengthwise to determine whether there is end play between the carriage-rack drive shaft and the ball bearing.

c. *Adjustment.* Loosen the setscrew in the collar. Push the carriage-rack drive shaft toward the collar until the shoulder of the carriage-rack drive shaft is against the ball bearing. Hold the drive shaft and push the collar against the ball bearing. Tighten the setscrew.

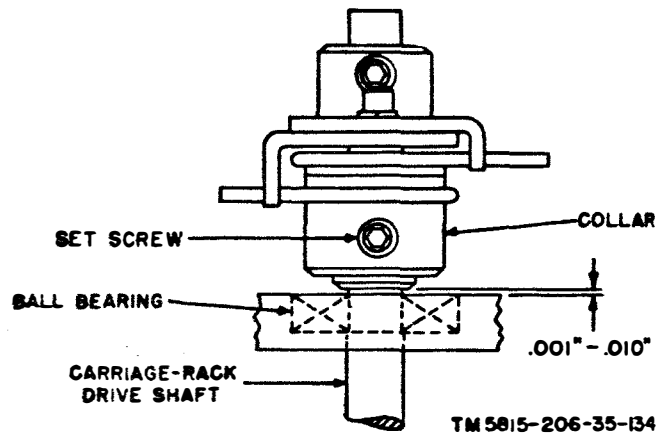

Figure 202. Carriage-rack drive-shaft adjustment.

210. Carriage-Feed Blocking Adjusting Lever and Carriage-Return Blocking-Lever Clearance Adjustments (TT-4B/TG) (fig. 203)

a. *Requirements.*

- (1) The carriage-return blocking lever should be centered with the adjusting plate on the double-blocking lever.
- (2) There should be 0.002- to 0.010-inch clearance between the carriage-return blocking lever and the carriage-feed blocking adjusting lever.

b. *Adjustments.*

- (1) Remove the carriage-return blocking adjusting lever, carriage-feed blocking adjusting lever, carriage-return blocking lever and the laminated washer. Peel the laminated washer to meet the requirement (a(1) above). Reassem-

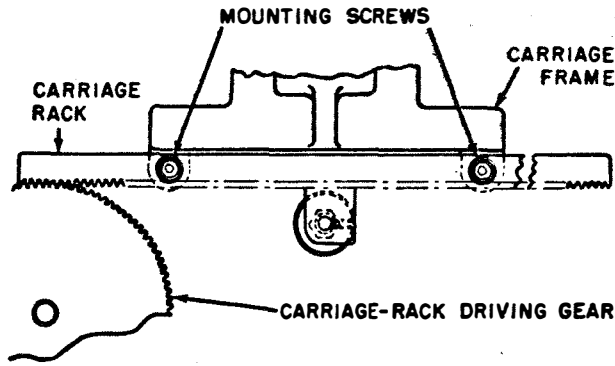

TM5815-206-35-198

Figure 201. Carriage-rack adjustment.



6-35-197

COLLAR

.001" - .010"

206-35-134

ustment.

ng Lever
ng-Lever
4B/TG)

ng lever
adjusting
lever.

.010-inch
ge-return
iage-feed

blocking
blocking
rn block-
washer.
meet the
Reassem-

ble the above items in reverse order and check the requirement.

- (2) Loosen the setscrews in the carriage-return blocking adjusting lever. Insert a 0.005-inch feeler gage between the carriage-feed blocking adjusting lever and the carriage-return blocking lever. Move the carriage-feed blocking adjusting lever against the feeler gage and tighten one setscrew friction-tight. Perform the carriage-return blocking adjusting lever adjustment (par. 211) before tightening the setscrews. Tighten the setscrews. Perform the carriage-feed blocking adjusting arm adjustment (par. 212).

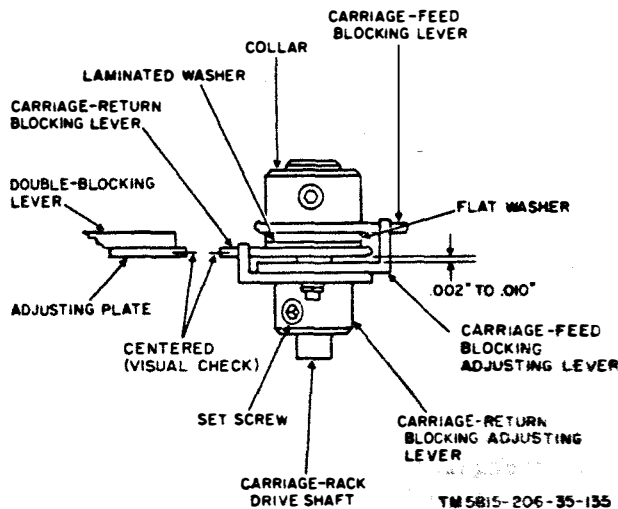

Figure 203. Carriage-feed blocking adjusting lever and carriage-return blocking-lever clearance (TT-4B/TG).

211. Carriage-Return Blocking-Lever Adjustment (TT-4B/TG) (fig. 204)

a. Requirement. There should be 0.010- to 0.020-inch clearance between the carriage-return blocking adjusting lever and the adjusting plate when the carriage is one space out from the left margin.

b. Method of Checking. With the carriage one space from the left margin, position the code rings for carriage return and turn the motor manually until the carriage-return sensing lever drops to the low point of its cam. The double-blocking lever will position the adjusting plate over the carriage-return blocking ad-

justing lever. Measure the clearance with feeler gages.

c. Adjustment. Loosen the two setscrews in the carriage-return blocking adjusting lever and rotate the lever to meet the requirement. Before tightening the setscrews, check the requirement given in paragraph 210. Tighten the setscrew. Check related adjustment (par. 212).

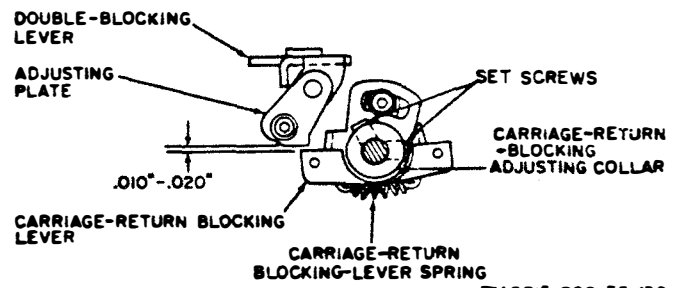

TM 5815-206-35-136

Figure 204. Carriage-return blocking-lever adjustment (TT-4B/TG).

212. Carriage-Feed Blocking-Lever Adjustment (fig. 205)

a. Requirement. There should be 0.002- to 0.010-inch clearance between the carriage-feed blocking lever and the extension of the carriage-feed pawl when the carriage is in the 68th space.

b. Adjustment. Move the carriage 68 spaces from the left-margin stopscrew and loosen the clamping screw. Rotate the carriage-feed blocking lever until the requirement (a above) is met. Tighten the screw.

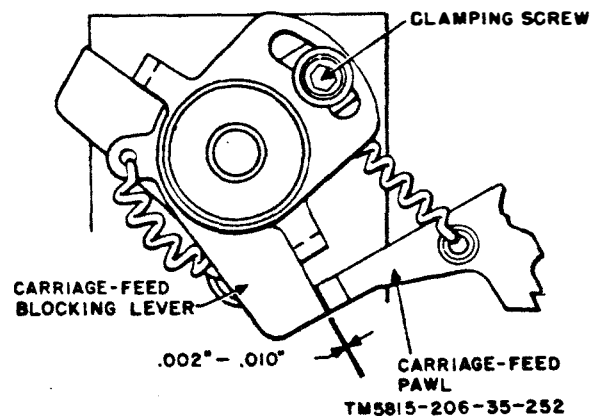

TM 5815-206-35-252

Figure 205. Carriage-feed blocking-lever adjustment.

213. Right-Margin Stop-Screw Adjustment (TT-4A/TG)

(fig. 206)

a. Requirement. The right-margin stopscrew should halt the carriage in the 73d space.

b. Adjustment. Loosen the locknut that holds the right-margin stopscrew and turn the screw counterclockwise for a few turns. Move the carriage 73 spaces from the left-margin stop screw. Turn the right-margin stopscrew until it touches the carriage. Tighten the locknut.

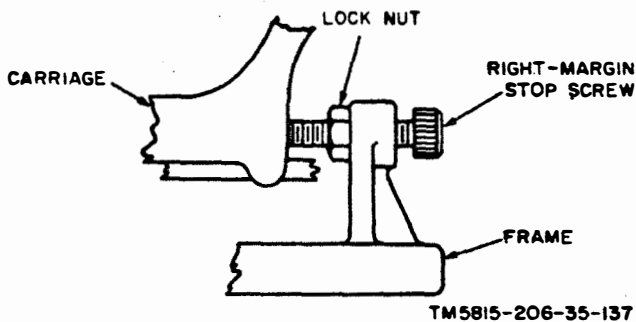

TM5815-206-35-137

Figure 206. Right-margin stop-screw adjustment (TT-4A/TG).

214. Carriage-Return Adjusting-Plate Adjustment (TT-4B/TG)

(fig. 207)

a. Requirement. There should be 0.015- to 0.025-inch clearance between the carriage-return blocking lever and the adjusting plate when the carriage is at the left margin. The carriage-return-clutch drum and the carriage-return-clutch disk (fig. 209) should not touch each other when the carriage-return operation is selected while the carriage is against the left-margin stopscrew.

b. Method of Checking. Position the carriage at the left margin and turn off the motor. Use a feeler gage to check the gap between the carriage-return blocking lever and the adjusting plate.

c. Adjustment. Position the carriage at the left margin. Loosen the mounting screw and move the adjusting plate to meet the requirement (a above). Tighten the mounting screw. Position the code rings for the carriage-return operation. Turn the motor manually and check to see that the members of the carriage-return clutch do not engage.

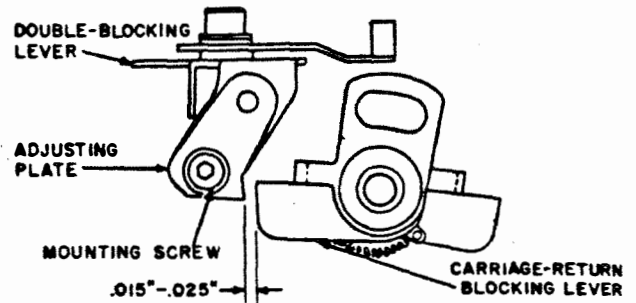

TM5815-206-35-139

Figure 207. Carriage-return adjusting plate adjustment. (TT-4B/TG).

215. Throw-Out Lever Adjustment (TT-4B/TG)

a. Requirement. There should be 0.010- to 0.020-inch clearance between the throw-out lever and the carriage-return latch-tripping arm (A, fig. 208) when the carriage is in the left hand margin position.

b. Method of Checking. Turn the motor on and press the CAR RET keylever, causing the carriage to move to the left hand margin. Turn the motor off and trip the transfer-lever latch. Hold the carriage-return blocking lever (fig. 207) downward and turn the motor slowly by hand until the carriage-return clutch members move against each other (tooth meet against tooth) (B, fig. 208). If the clutch teeth start to engage, hold the carriage-return-clutch drum out of engagement; continue turning the motor until the teeth are in line; and release the clutch drum. Use a feeler gage to check the requirement (a above).

c. Adjustment. Loosen the clamping screw in the throw-out lever. Move the throw-out lever to obtain the 0.010- to 0.020-inch gap while maintaining the requirement given in paragraph 199a(2); and tighten the clamping screw. Recheck the requirement (a above).

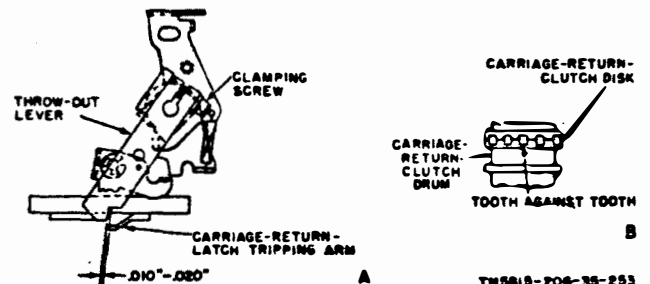

TM5815-206-35-253

Figure 208. Throw-out lever adjustment (TT-4B/TG).

216. Carriage-Return-Clutch Adjustment (TT-4A/TG)

(fig. 209)

a. Requirement. When the members of the carriage-return clutch are engaged, there should be 0.005- to 0.010-inch clearance between the carriage-return latch and the latching end of the carriage-return operating lever.

b. Adjustment. Loosen the clamping screw that holds the carriage-return operating lever. Position the lever to meet requirement (*a* above). Tighten the clamping screw. Check related adjustments (pars. 217 and 249).

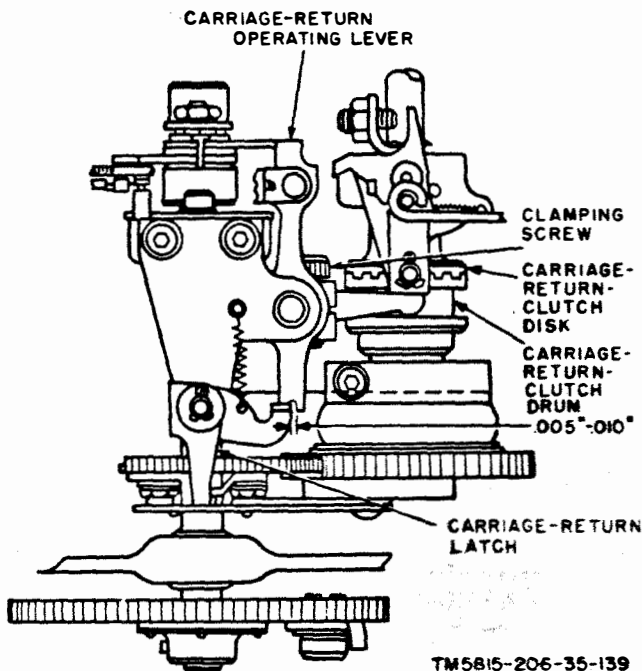

Figure 209. Carriage-return-clutch adjustment (TT-4A/TG).

217. Carriage-Return-Link Adjustment (TT-4A/TG)

(fig. 210)

Note. The carriage-return clutch adjustment (par. 216) should be completed before this adjustment is performed.

a. Requirement. The driven member of the carriage-return-clutch drum should move into engagement with the carriage return clutch disk when the carriage-return sensing lever drops to a low point of its cam.

b. Adjustment. Detach the adjusting link from the bell crank. Adjust the length of the link until the requirement (*a* above) is met. Reattach the adjusting link to the bell crank.

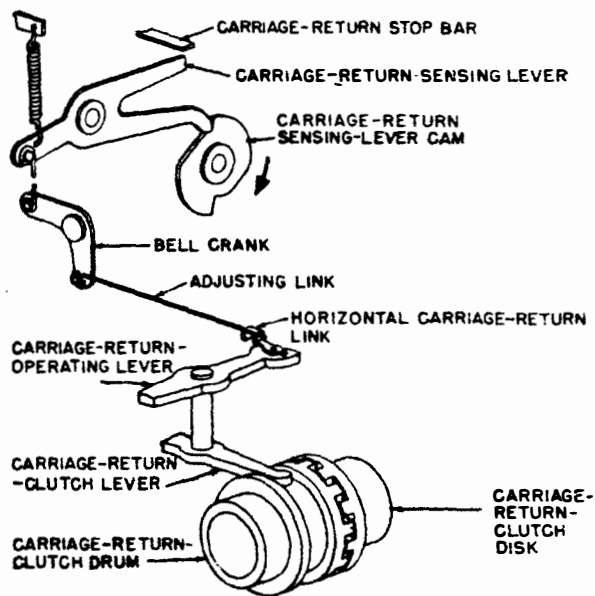

TM5815-206-35-254

Figure 210. Carriage-return-link adjustment (TT-4A/TG).

218. Carriage-Return Latch-Tripping-Arm Adjustment (TT-4A/TG)

(fig. 211)

a. Requirement. The latch-tripping arm should trip the carriage-return latch as the carriage strikes the left-margin stopscrew.

b. Adjustment. Make this adjustment after the carriage-feed and carriage-return clutches have been adjusted. Move the carriage to the left against the left-margin stop screw. Loosen the screws that hold the latch-tripping arm to the carriage-return drive gear. Disengage the carriage-feed clutch. Rotate the carriage-return gears until the protruding end of the decelerating cam is $\frac{3}{32}$ to $\frac{1}{8}$ inch from the top edge of the decelerating arm. It may be necessary to disengage the carriage rack from the carriage-return drive gear to permit sufficient rotation to get the proper adjustment. To do this, loosen the screws that hold the guide rail to the frame. Raise the carriage and disengage the rack from the gear. When the decelerating cam is $\frac{3}{32}$ inch to $\frac{1}{8}$ inch from the top edge of the decelerating arm, engage the rack and gear and tighten the rail mounting screws. Move the latch-tripping arm against the carriage-return latch and when the carriage-return operating lever unlatches, tighten the mounting

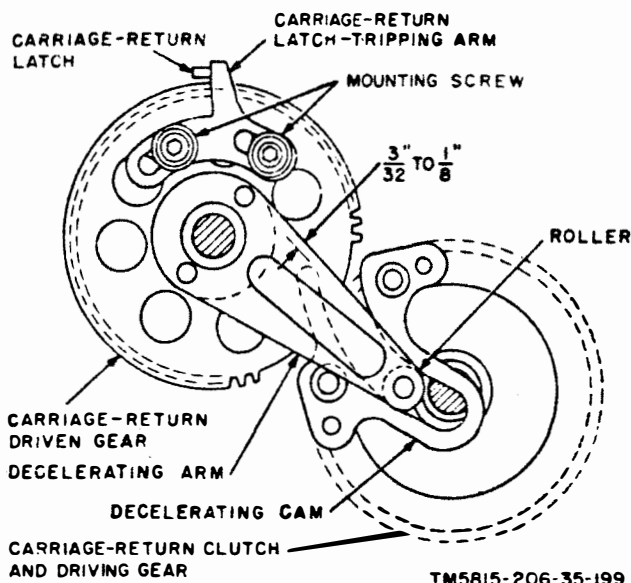

TM5815-206-35-199

Figure 211. Carriage-return latch-tripping-arm adjustment (TT-4A/TG).

screws. Check the carriage-feed clutch adjustment (par. 219).

219. Carriage-Feed Friction-Clutch Adjustment

(fig. 212)

a. Requirement. A force of 44 to 48 ounces should be required to hold the carriage motionless when the carriage-feed mechanism operates.

b. Method of Checking. Turn the motor on and position the carriage 10 spaces from the left-hand margin. Hook a 64-ounce spring scale at the point shown on figure 212. Hold the spring scale and press the space bar. The carriage will move to the right until the pull of the spring scale stops it. Move the spring scale slowly to the right and read it when the carriage starts to move again. Continue reading the spring scale in this manner until the carriage has reached the right hand margin. Note the point at which the reading of the spring scale is the lowest. At this point, the reading should equal the requirement (*a* above).

c. Adjustment. Turn the motor off. On the TT-4B/TG, loosen the clamping screw in the friction-adjusting collar, turn the collar to meet the requirement (*a* above) and tighten the clamping screw. On the TT-4A/TG, loosen the setscrews in the friction-adjusting collar,

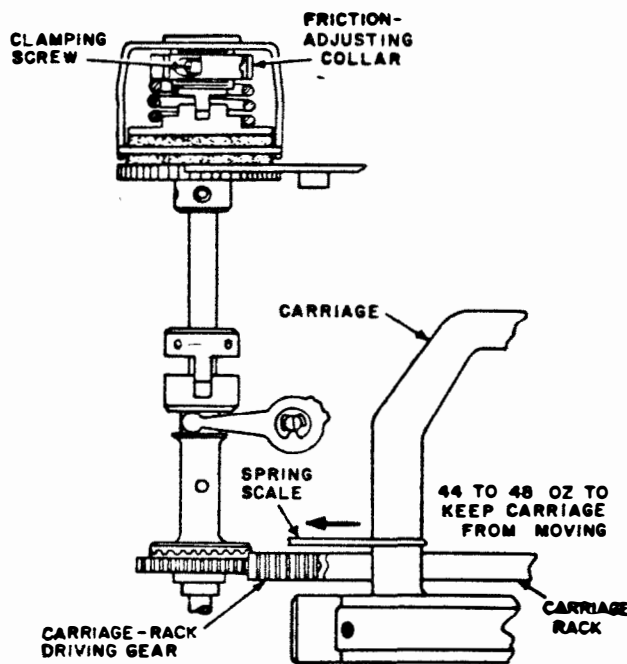

TM5815-206-35-140

Figure 212. Carriage-feed friction-clutch adjustment.

slide the collar to meet the requirement (*a* above) and tighten the setscrews. Recheck the requirement and readjust if necessary.

220. Carriage-Return Friction-Clutch Adjustment

(fig. 213)

a. Requirement. Tension of 48 to 56 ounces should be required to prevent the carriage from moving when the carriage-return mechanism is operating.

b. Method of Checking. Turn the motor on and move the carriage to the right hand margin. Hook a spring scale to the right hand side of the carriage. Hold the scale and securely press the CAR RET keylever. The carriage should move toward the left until the pull of the spring scale stops it. Move the scale slowly to the left and read it when the carriage starts to move again. Continue reading the scale while moving the carriage until the carriage is 10 spaces or more from the left hand margin. The lowest reading should equal the requirement (*a* above).

c. Adjustment. Turn on the motor and move the carriage away from the left margin until a socket head wrench can be inserted into the machine screw. Turn the motor off and insert the wrench into the clamping screw and loosen it.

Depress the manual carriage-return pushbutton and hold the carriage from moving while turning the motor manually until the carriage-return friction clutch is adjusted to meet the

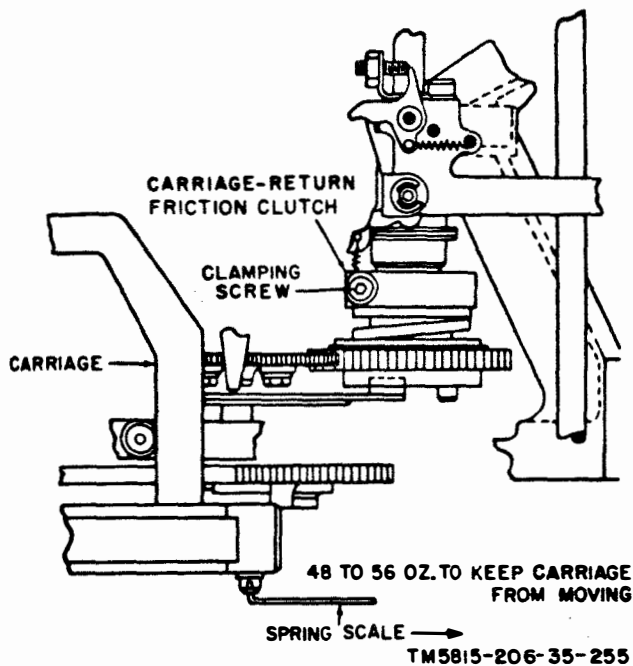

Figure 213. Carriage-return friction-clutch adjustment.

requirement (a above). Turn the motor clockwise manually to increase the tension; turn it counterclockwise to decrease the tension. Tighten the clamping screw, remove the wrench, and recheck.

221. Fulcrum Adjustment (TT-4B/TG)

a. *Requirement.* There should be 0.010- to 0.015-inch clearance between a selected function stop bar and its associated function-sensing lever when the sensing lever has dropped and is level with its stop bar (A, fig. 214).

b. *Adjustment.* Position the code rings for the figures-shift operation and turn the motor manually until the figures-shift sensing lever is in line with the figures-shift stop bar. Loosen the clamping screw that holds the figures-shift fulcrum (B, fig. 214). Loosen the self-locking hexagonal nut that holds the eccentric stud for the figures-shift fulcrum. Turn the eccentric stud until the requirement (a above) is met and tighten the locknut. Tighten the clamping screw and recheck the clearance. Use the same procedure for adjusting the carriage-return and line-feed fulcrums.

222. Square-Shaft Driven-Gear Adjustment (fig. 215)

a. *Requirement.* There should be a 0.002- to 0.005-inch clearance between the square-shaft driven gear and the flat washer.

b. *Method of Checking.* Insert a flat feeler gage between the square-shaft driven gear and the flat washer to determine the clearance.

c. *Adjustment.* Loosen the four setscrews in the square-shaft driven gear. Loosen the clamping screw of the function-selecting-arm claw. Hold the stop-arm shaft against the coding cage and press the square shaft toward the cage. Place a 0.020-inch flat feeler gage

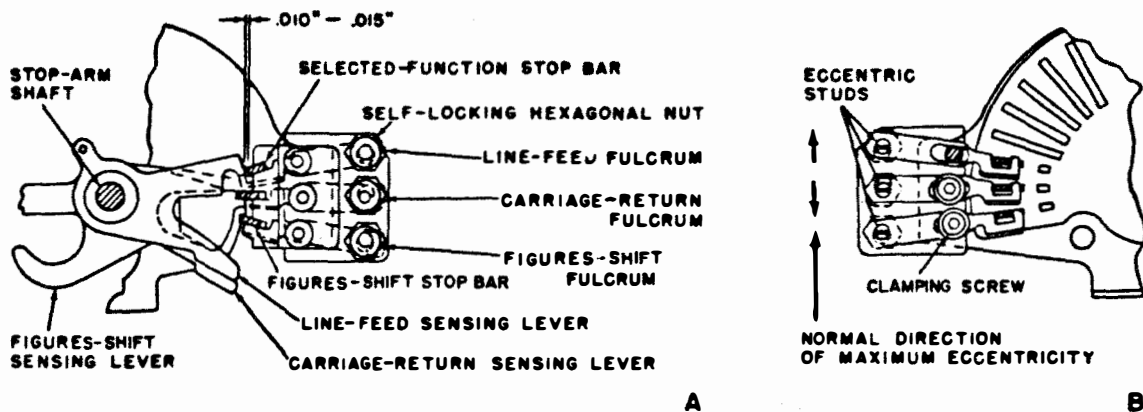

Figure 214. Fulcrum adjustment (TT-4B/TG).

TM5815-206-35-256

between the function-selecting-arm claw and the casting. Tighten the clamping screw of the function-selecting-arm claw. Replace the 0.020-inch flat feeler gage with a similar gage 0.030-inch thick. Press the function-selecting-arm claw against the feeler gage and press the stop-arm shaft against the code-ring gage. Position the square-shaft driven gear to obtain the requirement (*a* above) and tighten the four setscrews. Check the type-selecting and function-selecting arm adjustment (par. 224).

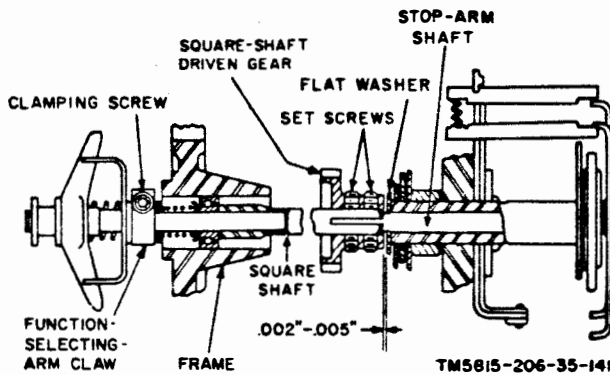

Figure 215. Square-shaft driven-gear adjustment.

223. Carriage-Rear-Support Bracket Adjustment (fig. 216)

a. Requirement. There should be minimum backlash between the square-shaft sliding gear and the type-selecting-arm gear.

b. Method of Checking. Attempt to rotate the type-selecting-arm gear back and forth at various position of the square shaft.

c. Adjustment. Move the carriage frame to the left hand margin for access to the carriage

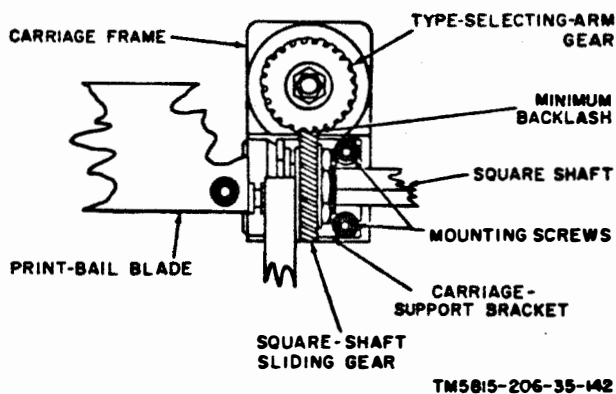

Figure 216. Carriage rear-support bracket adjustment.

rear-support bracket mounting screws. Loosen the two mounting screws and raise or lower the rear of the carriage to meet the requirement (*a* above). Tighten the screws and recheck the requirement. Check related adjustment (par. 224) for type-selecting arm alinement.

224. Type-Selecting-Arm and Function-Selecting-Arm Adjustments (fig. 217)

a. Requirements.

- (1) The type-selecting arm and the function-selecting arm should be in a definite positional relationship with the square-shaft stop arm.
- (2) There should be a 0.015- to 0.046-inch clearance between the casting and the function-selecting-arm claw.

b. Method of Checking.

- (1) Start the motor and press the Q key-lever. Note the alinement of the type-selecting arm and the Q connecting-bar slot in the guide plate. Press the Z keylever and note the alinement of the type-selecting arm and the Z connecting-bar slot.
- (2) Press the square-shaft stop arm toward the center of the page printer and check the requirement (*a*(2) above) with a feeler gage.

c. Adjustments.

- (1) Start the motor and press the Q key-lever. Loosen the clamping screw of the square-shaft stop arm and turn the square shaft until the type-selecting arm is alined with the Q connecting-bar slots in the guide plate. Hold the square shaft in this position, turn the square-shaft stop arm until it is against the Q stop bar, and tighten the clamping screw.
- (2) Press the Z keylever and check the alinement of the Z connecting bar and the type-selecting bar. If not alined, loosen the stop-arm clamping screw, turn the square shaft to move the type-selecting arm one-half the distance toward alinement and tighten the clamping screw. Press the Q and Z keylevers and check for equal aline-

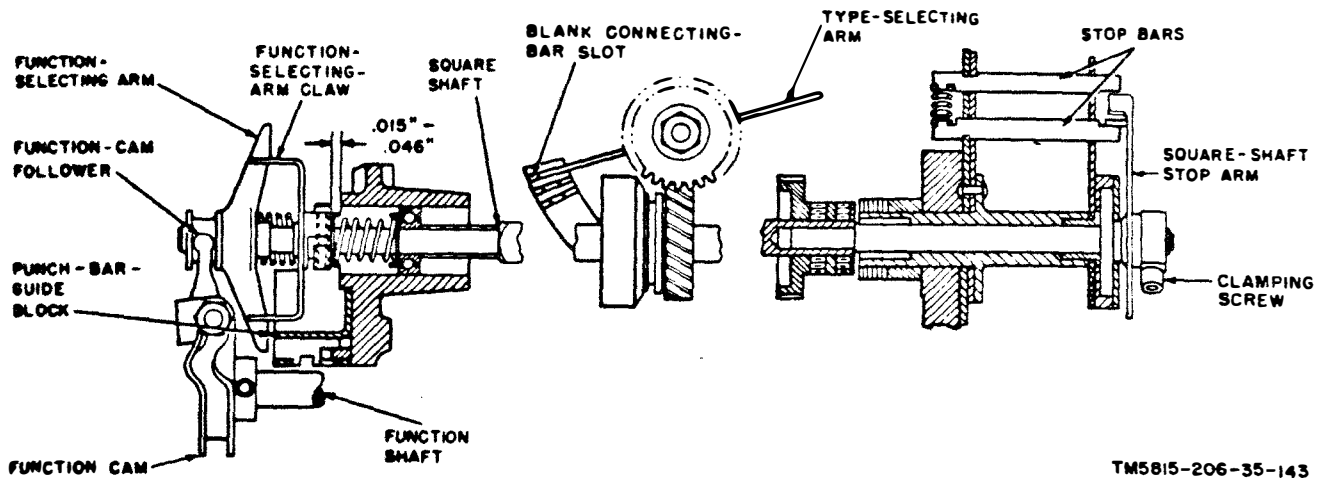

Figure 217. Type-selecting-arm and function-selecting-

TM5815-206-35-143

ment of the type-selecting arm and the Q and Z slots respectively.

- (3) Loosen the clamping screw in the function-selecting-arm claw. Set the code rings for the motor-stop operation (third and fifth code rings clockwise, others counterclockwise), and turn the square shaft until the square-shaft stop arm touches the H stop bar. Turn the function-selecting arm until it is alined with the motor-stop

punch bar. Position the function-selecting-arm claw on the shaft to meet requirement (a(2) above). Tighten the clamping screw and recheck the adjustment.

225. Square-Shaft Stop-Arm Torque Adjustment (fig. 218)

a. Requirement. When the motor is running and the function shaft is turning, a force

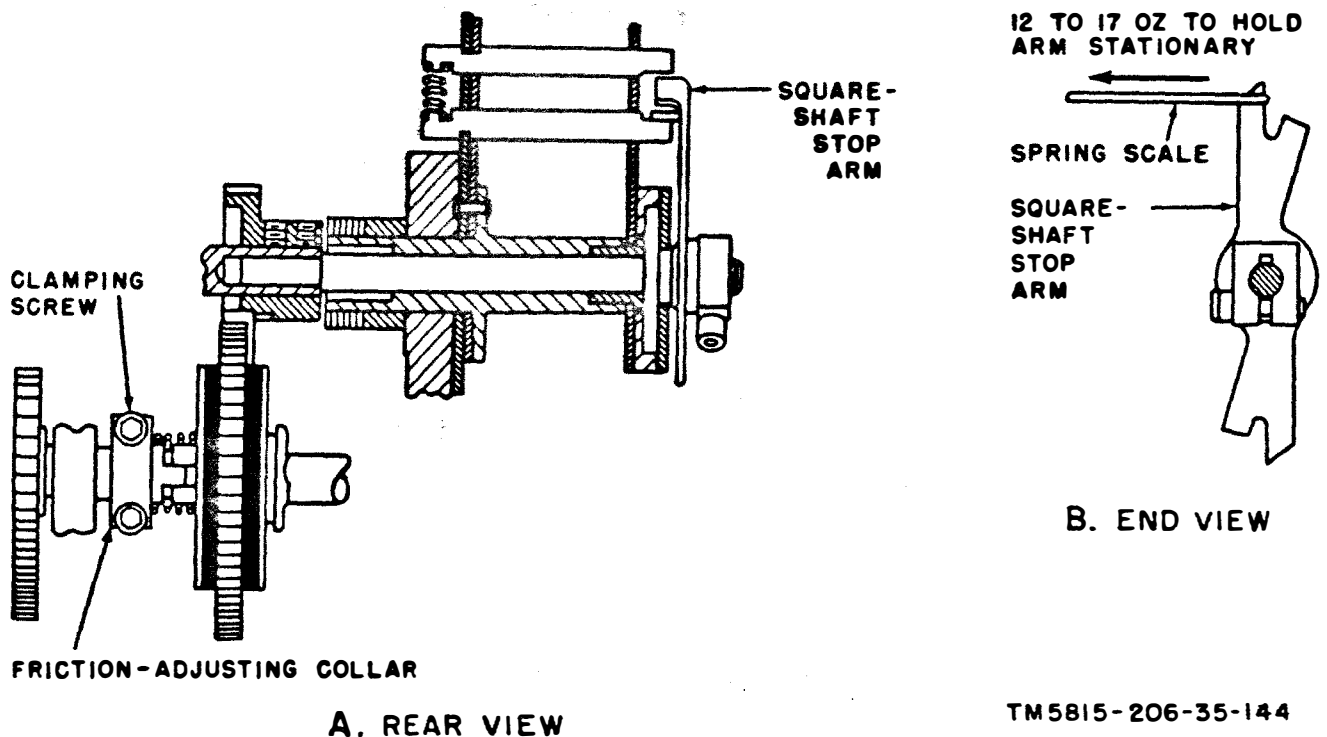

A. REAR VIEW

B. END VIEW

TM5815-206-35-144

Figure 218. Square-shaft stop-arm torque adjustment. arm adjustments.

of 12 to 17 ounces should be required to hold the square-shaft stop arm stationary.

b. Method of Checking. Start the motor and press the LTRS keylever. Engage one end of the square-shaft stop arm with the hook end of a spring scale and pull with a force exceeding 17 ounces. Press the LINE FEED keylever repeatedly and gradually decrease pull on the spring scale. When the square-shaft starts to move, check the reading of the scale.

c. Adjustment. Turn the motor off. Loosen the clamping screw in the friction-adjusting collar of the TT-4B/TG, turn the collar in the proper direction to obtain the requirement (a above), and tighten the clamping screw. Loosen the two setscrews in the friction-adjusting collar of TT-4A/TG, slide the collar to obtain the requirement, and tighten the setscrews. Recheck the requirement.

226. Print-Bail-Blade Adjustment

(fig. 219)

Note. The requirement given in paragraph 227a(1) must be met before this adjustment is made.

a. Requirement. There should be 50 percent minimum engagement of the print-bail blade in the grooved nut for the entire length of the blade. The blade should fit freely and remain in the confines of the grooved nut when the print-cam follower is against any portion of the print cam.

b. Method of Checking.

- (1) While manually moving the carriage from one end of the blade to the other, place the cam follower in various positions and note the engagement of the blade in the groove. Check the blade

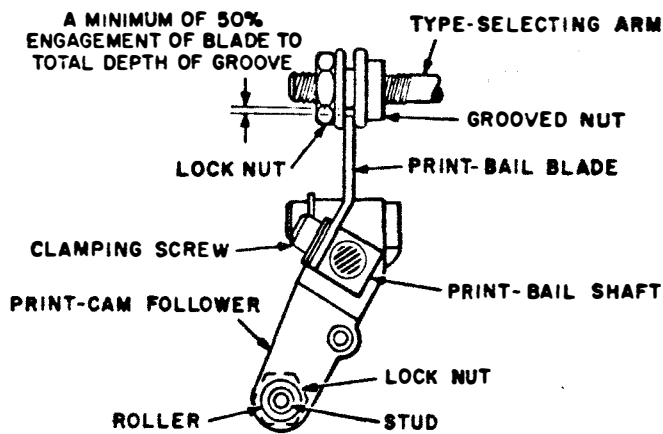

Figure 219. Print-bail-blade adjustment.

for freedom of movement in the groove. Check the entire length of the blade.

- (2) Place the cam follower in various positions and remove play in the type-selecting arm in an upward direction. Rock the blade back and forth to make certain it is contained in the groove for the entire length of the blade.

c. Adjustment. Loosen the screws that hold the print-bail blade and move the blade up or down until the requirement (a above) is met. Tighten the screws. Check requirements given in paragraph 227a(2) and (3).

227. Print-Bail and Ribbon-Lifter

Adjustments

(figs. 220 and 221)

a. Requirements.

- (1) The travel of the print-bail blade should be equal in both directions from the vertical center line of the print-bail blade shaft.
- (2) There should be nominally 0.030-inch clearance between the type-selecting arm and the guide plate for the connecting bars when the function shaft is in the midcycle position ($\frac{1}{4}$ turn from the stopped position). This clearance may be increased or decreased to obtain lighter or heavier printing. The minimum clearance is 0.008 inch.
- (3) There should be a 0.010- to 0.030-inch clearance between the front end of the type-selecting arm and the ribbon-lifter lever when the roller of the print-cam follower is against a high point of the print cam.

b. Adjustments.

- (1) Loosen the clamping screw on the print-cam follower and position the print-bail shaft to meet the requirement (a(1) above). Tighten the clamping screw.
- (2) Loosen the locknut on the rear of the type-selecting arm shaft. Rotate the grooved nut clockwise or counterclockwise until the requirement (a(2) above) is met. Tighten the locknut.
- (3) With the motor off and the teletypewriter in the stopped position, trip the

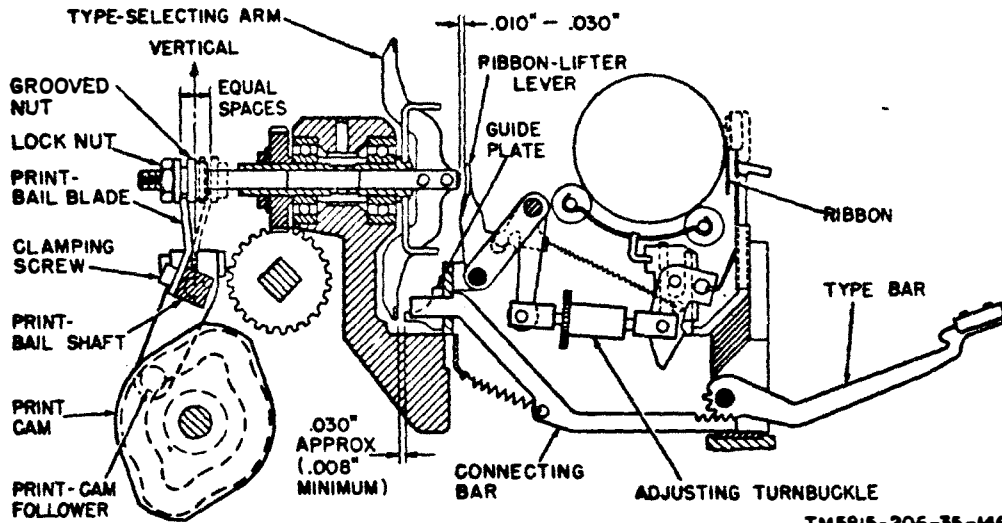

TM5815-206-35-146

Figure 220. Print-bail and ribbon-lifter adjustments (TT-4A/TG).

transfer-lever latch and turn the motor manually until the roller of the print-cam follower is against a high point of the print cam. To obtain the required clearance on the TT-4A/TG, use a screw driver, inserted from the front of the carriage, to turn the adjusting turnbuckle to obtain the required clearance. On the TT-4B/TG, loosen the two clamping screws in the adjusting links. Hold the ribbon-lifter lever away from the front of the type-selecting arm. Insert a flat feeler gage

between the front of the type-selecting arm and the ribbon-lifter lever, position the adjusting links to meet the requirement (a(3) above), and tighten the two clamping screws.

Note. The adjustment given in b(2) above should always be made when changing the operating speed of the teletypewriter.

228. Platen-Trough-Spring Adjustment (TT-4B/TG)

(fig. 222)

a. Requirement. A force of 3 to 6 ounces, applied as shown in B, figure 222, should be re-

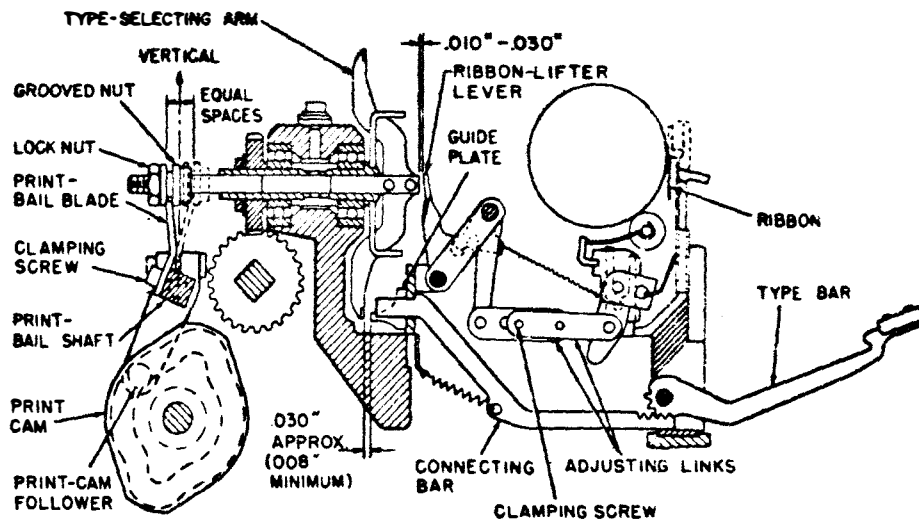

TM5815-206-35-257

Figure 221. Print-bail and ribbon-lifter adjustments (TT-4B/TG).

quired to start the platen trough guide moving downward.

b. Adjustment. Remove the hinge pin; wind or unwind the platen trough spring (A, fig. 222) to meet the requirement (*a* above); and replace the pin.

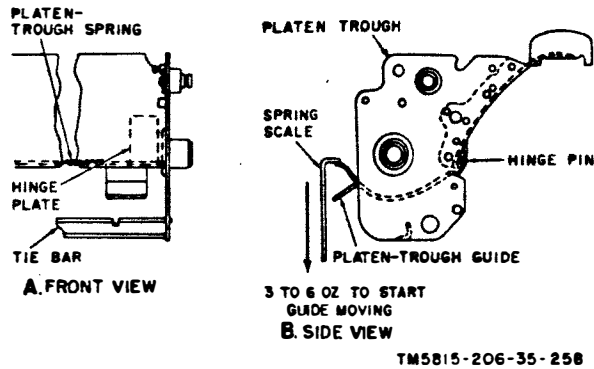

TM5815-206-35-258

Figure 222. Platen-trough-spring adjustment (TT-4B/TG).

229. Platen-Shaft End-Play Adjustment (fig. 223)

a. Requirement. There should be 0.002- to 0.005-inch clearance between the shaft collar and the bearing when the platen shaft is held all the way to the left.

b. Adjustment. Loosen the setscrews in the shaft collar and position the collar to meet the requirement (*a* above). Tighten the setscrews and recheck the requirement.

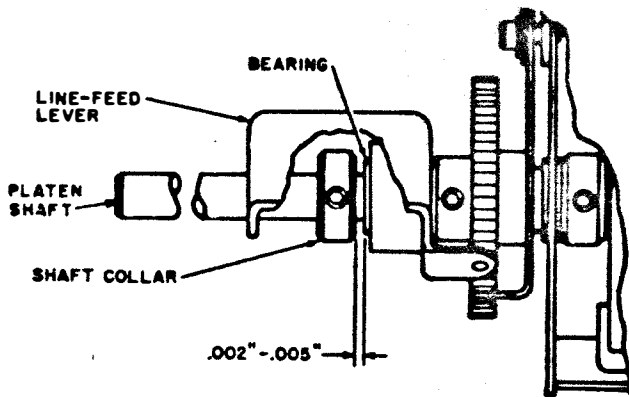

TM5815-206-35-147

Figure 223. Platen-shaft end-play adjustment.

230. Platen-Trough End-Play Adjustment (fig. 224)

a. Requirement. There should be a .002- to

.005-inch clearance between the platen trough and the platen collar when the platen trough and the platen shaft are held to the left.

b. Adjustment. Loosen the two setscrews that hold the platen to the platen shaft. Position the platen to meet the requirement (*a* above). Tighten the setscrews and recheck the requirement.

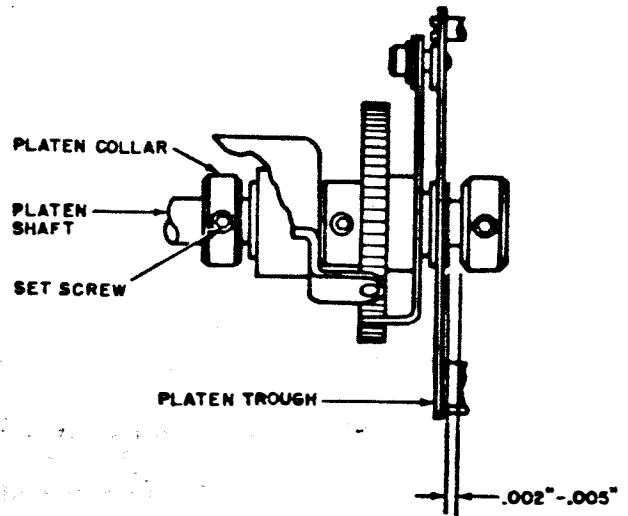

TM5815-206-35-148

Figure 224. Platen-trough end-play adjustment.

231. Paper-Guide Adjustment (TT-4B/TG)

a. Requirement. The slot of each paper guide should be centered against each metal end of the platen (A, fig. 225). Both paper guides should be in contact with the plates (B, fig. 225).

b. Adjustment. Loosen the setscrew in each paper guide. Position the right hand paper guide to meet the requirement (*a* above) and tighten its setscrew. Position the left-hand paper guide in the same manner. Make certain each paper guide is in contact with the platen before tightening its setscrew.

232. Platen Pressure-Roller Adjustment (TT-4B/TG) (fig. 226)

a. Requirement. There should be sufficient pressure against the platen by the pressure roller to pull the paper one or two spaces when the line-feed operation takes place. There should be no pressure applied to the copy when the

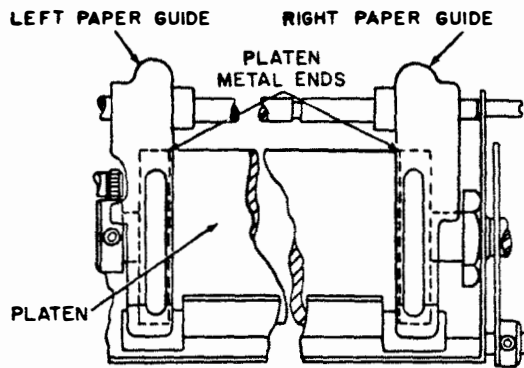

A. FRONT VIEW

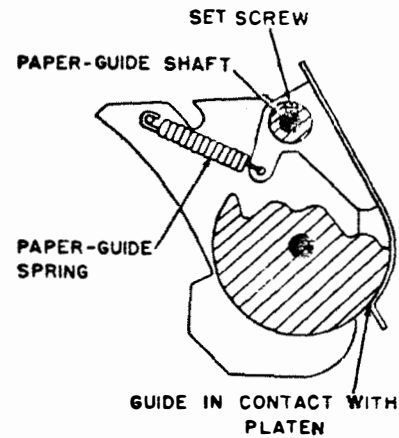

B. CROSS SECTION

TM5815-206-35-149

Figure 225. Paper-guide adjustment (TT-4B/TG).

pressure-roller lever is in the unlatched position.

b. *Adjustment.* Place the leading edge of the tab of the pressure-roller lever in line with the edge of the notch in the platen-lever latch. Loosen the setscrews and rotate the pressure-roller operating shaft so that the pressure roller touches the platen. Tighten the setscrews. Be certain the roller clears the copy in the unlatched position.

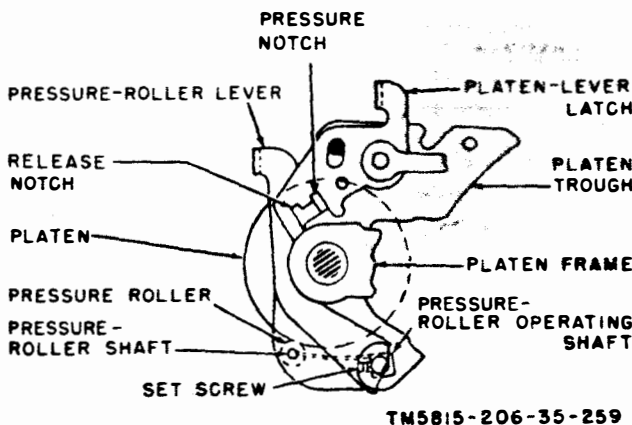

TM5815-206-35-259

Figure 226. Platen pressure-roller adjustment (TT-4B/TG).

233. Platen Pressure-Rollers Adjustment (TT-4A/TG)

(fig. 227)

a. *Requirement.* There should be sufficient pressure against the platen by the pressure rollers to pull the paper one or two line spaces when the line-feed operation takes place.

b. *Adjustment.* Pull the pressure-roller lever to the released position and loosen the setscrews. Push the rollers against the platen manually. Leave the lever in the released position and tighten the setscrews.

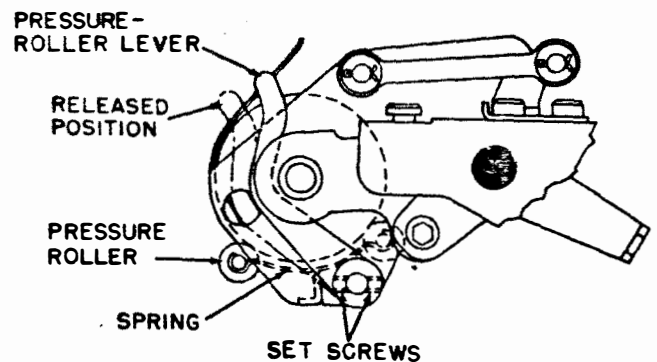

TM5815-206-35-260

Figure 227. Platen pressure-rollers adjustment (TT-4A/TG).

234. Platen-Assembly End-Play and Positioning Adjustment (fig. 228)

a. *Requirement with Platen Assembled.*

- (1) There should be $\frac{1}{64}$ - to $\frac{3}{64}$ -inch clearance between the end of the platen-latching arm and the end of the slot in the aperture gate.
- (2) There should be 0.002- to 0.005-inch end play of the platen assembly.
- (3) The platen shift link and line feed

connecting link should be straight and free on their pivots.

b. *Method of Checking.* Take up the platen end play to the left (selector side) and check requirements as follows:

- (1) With a scale.
- (2) With feeler gages.
- (3) Visually.

c. *Adjustments.* With platen assembled, loosen the platen eccentric pivot setscrews.

- (1) Take up the end play of platen to the left and position the platen to meet the requirements (a(1) above). Push left-hand eccentric pivot against the assembly and tighten the setscrew. Recheck requirement.
- (2) Hold the platen against the left-hand eccentric pivot, and position the right eccentric pivot to meet the requirement (a(2) above). Tighten its setscrew and recheck the requirement.
- (3) Take up the end play of the platen to the left and position the platen to meet the requirement (a(3) above). Push the left-hand eccentric pivot against the assembly and tighten the setscrew. Recheck the requirement.

Note. Check related adjustment (par. 235).

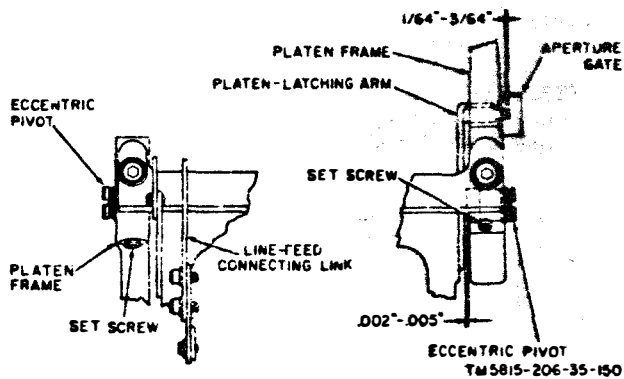

Figure 228. Platen-assembly end-play and positioning adjustment.

235. Character-Printing Density Adjustment

a. *Requirement.* All characters of a line should be printed equally dark.

b. *Adjustment.* Print a full line of the same character. If all characters are not printed equally dark, loosen the setscrews (A, fig. 229) in each side frame; position the eccentric pivots

for maximum eccentricity in the direction shown in B, figure 229; press the pivots inward; tighten the setscrews; and print another line of characters. If printing density still varies, readjust the pivots as necessary to eliminate the variation. Check the related adjustments (pars. 237, 239, and 241).

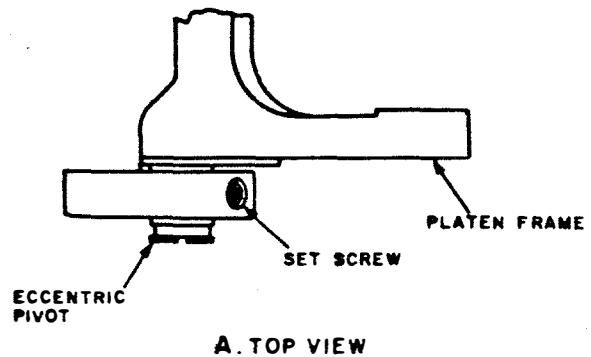

A. TOP VIEW

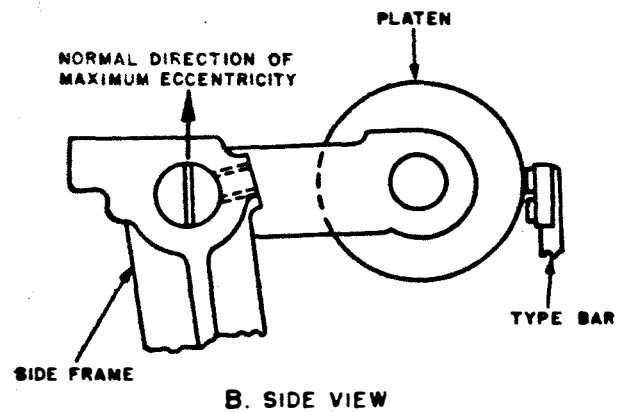

B. SIDE VIEW

TM5815-206-35-151

Figure 229. Character-printing density adjustment.

236. Figures-Shift Preliminary Adjustment (fig. 230)

a. *Requirement.* The platen latch (A, fig. 40) should engage the lug on the aperture gate when the figures-shift-cam follower is moved downward as far as possible by the figures-shift cam. The spring of the figures-shift link on the TT-4B/TG must not stretch when the figures-

shift-cam follower is in the fully downward position.

b. *Adjustment.* Loosen the clamping screw (fig. 230); position the figures-shift arm to meet the requirement; tighten the clamping screw; and recheck the requirement. Check the related adjustment (par. 237).

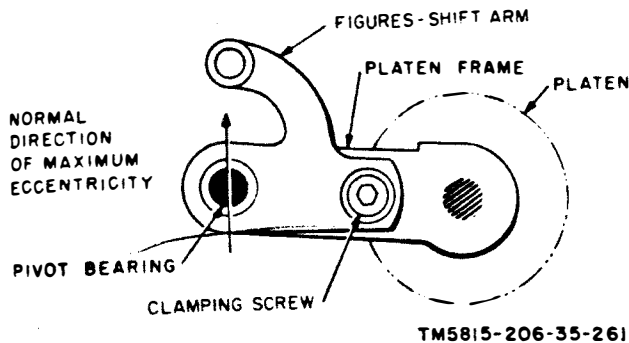

Figure 230. Figures-shift preliminary adjustment.

237. Figures-Shift Position Adjustment (fig. 231)

Note. The figures-shift preliminary adjustment (par. 236) must be made before this adjustment is performed.

a. *Requirement.* Characters should be printed evenly without being cut off at the top or the bottom when the platen is in the figures position.

b. *Method of Checking.* With the platen in the figures position, send repeated R and Y signals and inspect the typed result for meeting the requirement (a above).

c. *Adjustment.* Loosen the platen-latching arm mounting screw. Position the platen-latching arm up or down to meet the requirement (a above). Tighten the clamping screw. If all adjustments in sequence are not being made, check the letters-shift position adjust-

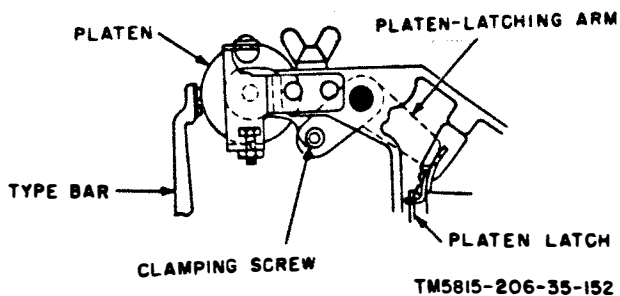

Figure 231. Figures-shift position adjustment.

ment (pars. 238 and 239) and the platen shift final adjustment (par. 240).

238. Letters-Shift Position Adjustment (TT-4A/TG) (fig. 232)

a. *Requirement.* Characters printed with the platen in the letters-shift position must be aligned with characters printed with the platen in the figures-shift position.

b. *Method of Checking.* With the platen first in the figures position and then in the letters position, send repeated No. 5 and T signals and inspect the typed result for alinement.

c. *Adjustment.* Loosen the locknut that holds the platen stop screw. If the letters print below the figures, turn the stop screw counterclockwise. If the letters print above the figures, turn the stop screw clockwise. It may be necessary to alter the figures-shift position adjustment (par. 237) to be able to align the characters. Recheck the requirement (a above). Readjust if necessary until the requirement is met. Tighten the locknut.

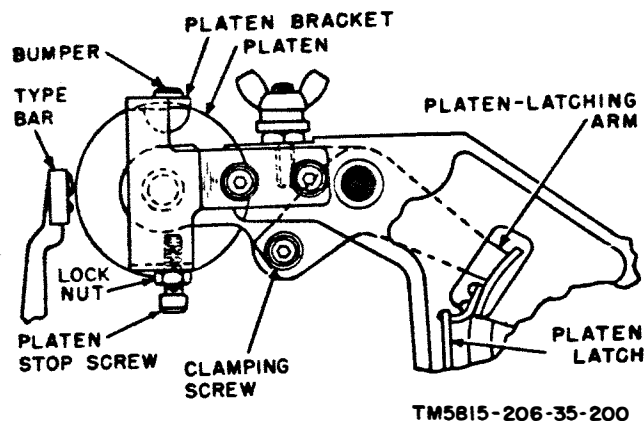

Figure 232. Letters-shift position adjustment (TT-4A/TG).

239. Letters-Shift Position Adjustment (TT-4B/TG) (fig. 233)

a. *Requirement.* Characters printed when the platen is in the letters-shift position should be aligned with characters printed when the platen is in the figures-shift position.

b. *Method of Checking.* Turn the motor on and operate the keys of the keyboard-transmitter to cause the symbols T and 5 to be printed

alternately. Inspect the typed result for character alinement.

c. Adjustment. Loosen the locknut that holds the platen stop screw. If the letter T was printed *below* the figure 5, turn the platen stop-screw counterclockwise. If the letter T was printed *above* the figure 5, turn the platen stop screw clockwise. It may be necessary to alter the figures-shift position adjustment (par. 237) to obtain the proper alinement. Tighten the locknut. Perform the platen-shift final adjustment (par. 240).

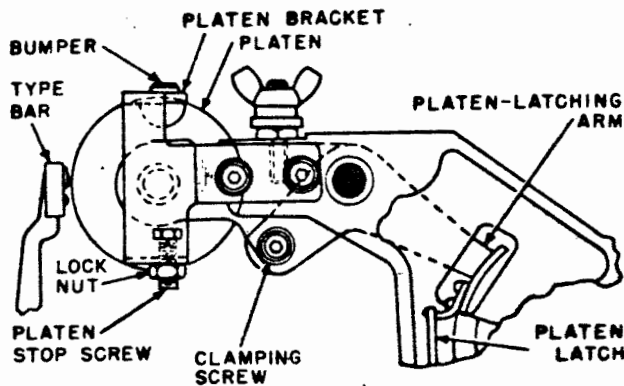

TM5815-206-35-171

Figure 233 Letters-shift position adjustment (TT-4B/TG).

240. Platen-Shift Final Adjustment (fig. 234)

Note. Complete the figures-shift position adjustment (par. 237) before starting this adjustment.

a. Requirement. There should be 0.005- to 0.020-inch clearance between the platen latch and the lug on the aperture gate when the roller of the figures-shift cam follower is against a lobe of the figures-shift cam.

b. Method of Checking. Select the figures code group and turn the motor by hand until the roller of the figures-shift cam follower is against a lobe of the figures-shift cam. Check the requirement (*a* above) with feeler gages.

c. Adjustment. Loosen the clamping screw. Reposition the platen-latching arm to meet the requirement. Tighten the clamping screw. It may be necessary to repeat the figures position adjustment (par. 237) to be able to get the required clearance.

Note. For operation at 100 words per minute, decrease the requirement to 0.001 to 0.005 inch.

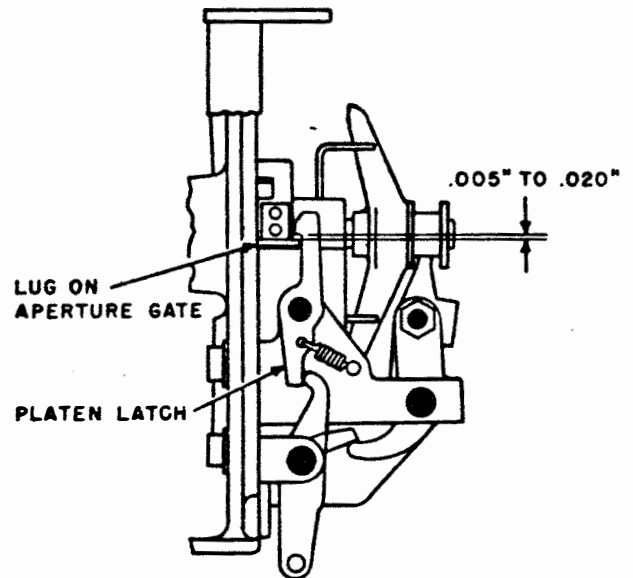

TM5815-206-35-201

Figure 234. Platen-shift final adjustment.

241. Platen-Blocking-Arm Adjustment (TT-4B/TG) (fig. 235)

a. Requirement. There should be 0.010- to 0.020-inch clearance between the platen-stop screw and the lower surface of the platen

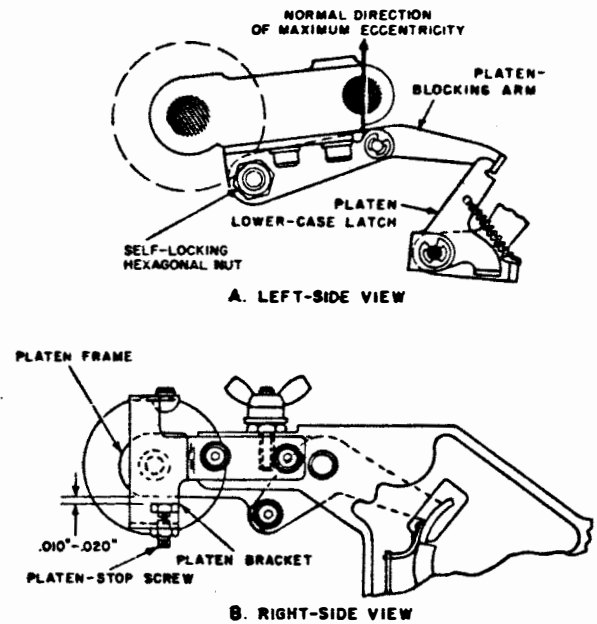

TM5815-206-35-153

Figure 235. Platen-blocking-arm adjustment (TT-4B/TG).

frame (B, fig. 235) when the platen is raised manually to the figures-shift position.

b. *Adjustment.* Loosen the self-locking hexagonal nut (A, fig. 235); position the platen-blocking arm to meet the requirement; and tighten the locknut.

242. Platen-Blocking-Arm Bracket Adjustment (TT-4B/TG) (fig. 236)

a. *Requirement.* There should be 0.005- to 0.020-inch clearance between the figures-shift sensing lever and the platen lower-case latch when other than the figures or letters combination is selected and when the function camshaft is rotated so that the figures-shift sensing lever is in contact with the figures-shift stop bar.

b. *Method of Checking.* Select a code combination other than figures or letters. Trip the transfer-lever latch by hand and rotate the motor until the figures-shift sensing lever drops off the high portion of its restoring cam and is blocked by the figures-shift stop bar. Measure the clearance between the figures-shift sensing lever and the platen lower-case latch.

c. *Adjustment.* Loosen the mounting screws of the platen-blocking-arm bracket. Position the bracket until the requirement (a above) is met. Tighten the mounting screws. Recheck for clearance.

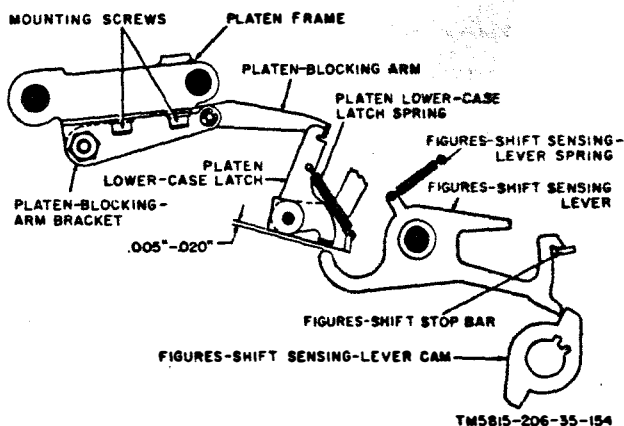

Figure 236. Platen-blocking-arm bracket adjustment (TT-4B/TG).

243. Line-Feed Detent Adjustment (fig. 237)

a. *Requirement.* With the single-double line-

feed lever in the double line-feed position, the line-feed pawl should enter squarely into the notches of the line-feed ratchet.

b. *Method of Checking.* Manually move the line-feed connecting link toward the rear of the machine and check the requirement as the line-feed pawl moves into a notch in the line-feed ratchet.

c. *Adjustment.* Loosen the plain round nut that holds the detent eccentric stud in position on the platen trough. Turn the eccentric stud in the proper direction to meet the requirement (a above). Tighten the plain round nut. Recheck the requirement.

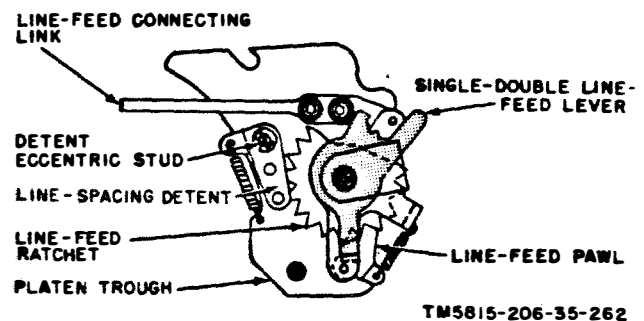

Figure 237. Line-feed detent adjustment.

244. Line-Feed Bell-Crank Adjustment (TT-4B/TG) (fig. 238)

a. *Requirement.* The roller of the line-feed-cam follower should move under the line-feed cam when the line-feed sensing lever is pulled to the low point of the line-feed restoring cam.

b. *Method of Checking.* Set up the line-feed code combination in the Y-levers (rotate the

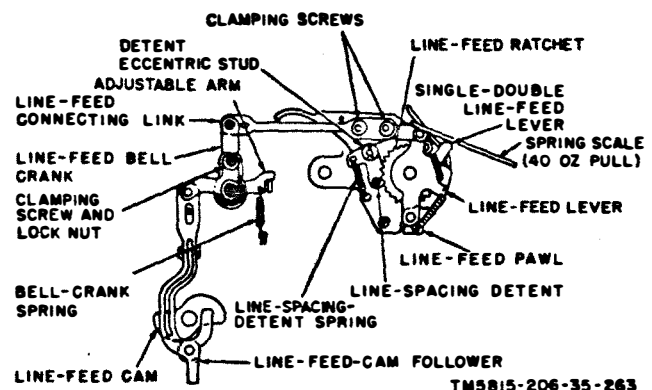

Figure 238. Line-feed bell-crank adjustment (TT-4B/TG).

No. 2 Y-lever clockwise and the remaining Y-levers counterclockwise) and manually trip the transfer-lever latch. Rotate the motor by hand until the line-feed sensing lever is pulled to the low point of the line-feed restoring cam. At this time, the roller of the line-feed-cam follower should just move under the line-feed operating cam. Check the requirement at both low points of the line-feed operating cam.

c. Adjustment. Loosen the hexagonal nut and position the adjustable bell crank until the requirement (a above) is met. Tighten the nut. Recheck the requirement. Check related adjustment (par. 245).

245. Line-Feed Connecting-Link Adjustment (TT-4B/TG) (fig. 238)

a. Requirements.

- (1) A pull of 40 ounces applied to the line-feed lever should not prevent the line-feed mechanism from turning the platen when the single-double line-feed lever is in either the single or double line-feed position.
- (2) When the line-feed operation is completed, the line-feed pawl should be clear of the line-feed ratchet.

b. Method of Checking.

- (1) Hook a spring scale on the upper arm of the line-feed lever and exert a downward and forward pull of 40 ounces on the spring scale while receiving repeated line-feed code combinations. This should not prevent the line-feed mechanism from turning the platen.
- (2) When the teletypewriter is in the stopped position, attempt to rotate the platen forward and backward. It should rotate freely.

c. Adjustment. Loosen the clamping screws that hold the line-feed connecting link and position the single-double line-feed lever for double line feed operation. Select the line-feed code combination and turn the motor by hand until the line-feed-cam follower is on the high part of the line-feed cam. Rotate the line-feed lever (fig. 238) until the platen has advanced two line spaces. Tighten the clamping screws to hold the connecting link in this position. Continue to turn the motor until the line-feed op-

eration is completed and the parts are restored to their normal position. Be certain that the requirement (a(2) above) is met.

246. Line-Feed Connecting-Link Adjustment (TT-4A/TG) (fig. 239 and 240)

Note. Complete the line-feed detent adjustment (par. 243) before starting this adjustment.

a. Requirements.

- (1) Selection of the line-feed combination should cause the line-feed mechanism to turn the platen one line space when the single-double line-feed lever is in the position shown in B, figure 240, and two lines spaces when it is in the position shown in A, fig. 240.
- (2) When the line-feed operation is completed, the line-feed pawl should be clear of the line-feed ratchet.

b. Adjustments.

- (1) Loosen the clamping screws (fig. 239). Select the line-feed combination and turn the motor manually until the line-feed-cam follower is against a high part of its cam. Rotate the line-feed lever until the platen has advanced one line space. Tighten the clamping screws. Continue turning the motor until line-feed operation is completed.
- (2) Check the requirement (a(2) above) visually.

247. Margin-Bell and Bracket Adjustment (fig. 241)

a. Requirements.

- (1) The margin bell should ring when the carriage has moved 66 spaces from the left hand margin.
- (2) There should be a clearance of 0.020- to 0.025-inch between the margin-bell pawl and the pawl trip arm at their closest point when the carriage is 66 spaces from the left hand margin.

b. Method of Checking.

- (1) Space the carriage 65 spaces from the left hand margin. Depress the space bar; the margin bell should ring.
- (2) With the carriage 66 spaces from the left hand margin, move the margin-bell clapper up and down to deter-

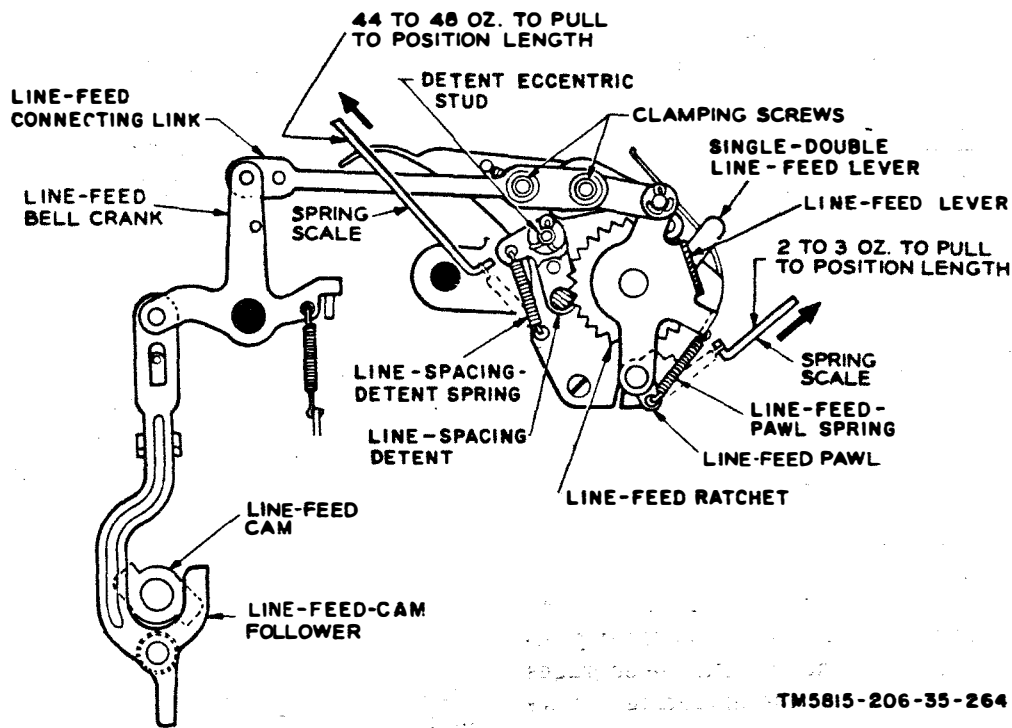

Figure 239. Line-feed mechanism, side view (TT-4A/TG).

c. Adjustments.

- (1) On the TT-4A/TG, loosen the two clamping screws, or on the TT-4B/TG, loosen the two clamping nuts which hold the margin-bell latch-tripping arm to the carriage-rack driving gear. Position the latch-tripping arm to meet the requirement (a(1) above) and tighten the clamping nuts.

- (2) Loosen the clamping screws that hold the margin-bell bracket to the teletypewriter frame and position the bracket to meet the requirement (a(2) above). Maintain a clearance between the pawl and the face of the driving gear.

248. Manual Carriage-Return Bracket Adjustment (TT-4B/TG)
(fig. 242)

a. Requirement. There should be 0.005- to 0.015-inch clearance between the pawl and the

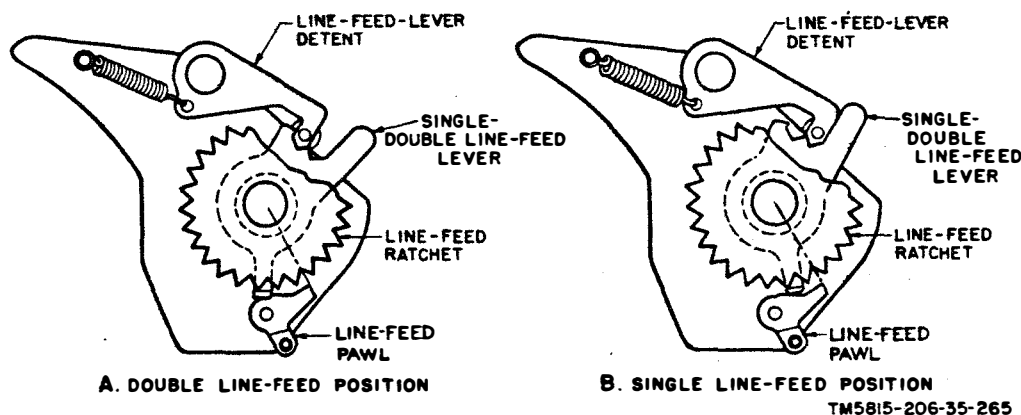
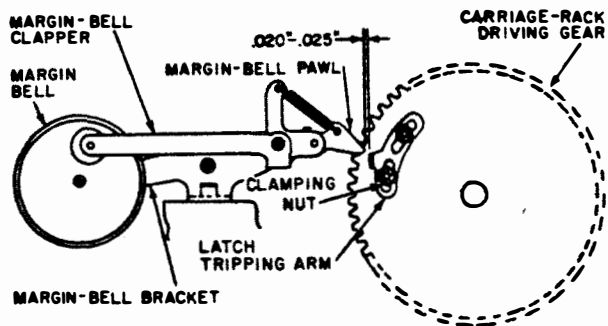

Figure 240. Positions of single-double line-feed lever.



TM5815-206-35-266

Figure 241. Margin-bell and bracket adjustment.

double-blocking lever (TT-4B/TG) or the carriage-return clutch-actuating lever (TT-4A/TG) when both the pawl and lever are in the unoperated position.

b. *Method of Checking.* Place the pawl and the double-blocking lever (or carriage-return clutch-actuating lever) in the unoperated position. Check the requirement with feeler gages

c. *Adjustment.* Loosen the mounting screws and position the manual carriage-return bracket to meet the requirement (a above). Tighten the mounting screws and recheck the requirement.

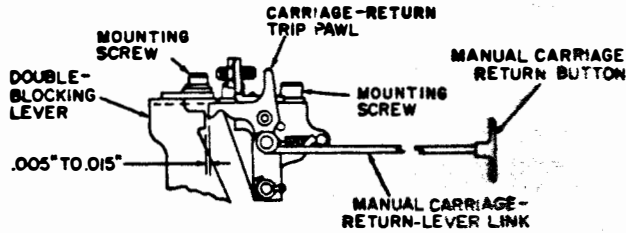

TM5815-206-35-155

Figure 242. Manual carriage-return bracket adjustment (TT-4B/TG).

249. Carriage-Return Trip-Pawl Adjustment (TT-4A/TG) (fig. 243)

Note. Complete the carriage-feed clutch drum adjustment (par. 202) before performing this adjustment.

a. *Requirement.* When the manual carriage-return button is pushed, the carriage-return clutch should first latch in the engaged position and the carriage-return trip pawl should not clear the corner of the carriage-return operating lever.

b. *Adjustment.* Turn the adjusting screw in, for less engagement, or out, for more engagement.

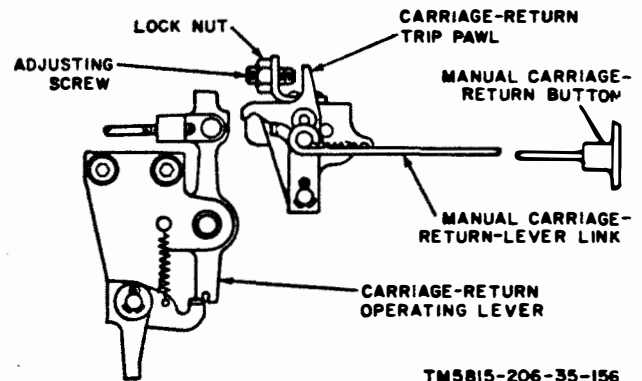

TM5815-206-35-156

Figure 243. Carriage-return trip-pawl adjustment (TT-4A/TG).

250. Carriage-Return Trip-Pawl Adjustment (TT-4B/TG) (fig. 244)

a. *Requirement.* The carriage-return trip pawl should touch and then move past the double-blocking lever when the lever is held manually in the fully operated position (carriage-return clutch engaged) and the manual carriage-return button is operated.

b. *Method of Checking.* Manually rotate the double-blocking lever to engage the carriage-return clutch. Hold the double blocking lever in the operated position and manually operate the manual carriage-return button. Check the requirements.

c. *Adjustment.* Loosen the locknut and position the adjusting screw to meet the requirements in a above. Tighten the locknut, and recheck the requirement.

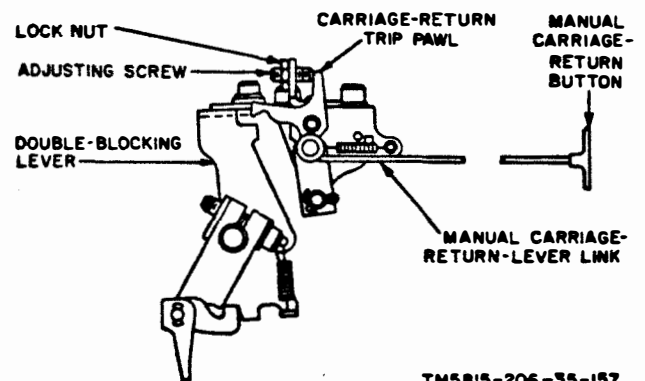

TM5815-206-35-157

Figure 244. Carriage-return trip-pawl adjustment (TT-4B/TG).

251. Ribbon-Feed Mounting Adjustment (fig. 245)

Note. Perform this adjustment only when assembling the ribbon-feed mechanism to the type-bar carriage.

a. Requirement. The ribbon-spool shafts should be 5 inches apart and parallel within 0.010 inch.

b. Adjustment. Loosen the screws mounting the ribbon-feed mechanism. Position the mechanism to meet the requirement (a above). Tighten the mounting screws and recheck the requirement.

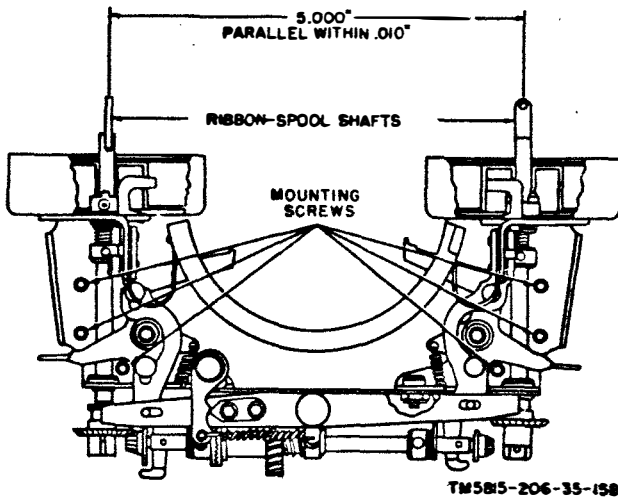

Figure 245. Ribbon-feed mounting adjustment.

252. Ribbon-Spool Shaft Adjustment (fig. 246)

a. Requirement. There should be equal en-

gagement of the bevel gears at each end of the ribbon-spool shaft.

b. Adjustment. Loosen the setscrews in the right hand collar, spring collar, and driven clutch member. Move the shaft in the proper direction to meet the requirement (a above) and tighten the setscrew in the driven clutch member. Place a 0.002- to 0.004-inch feeler gage between the driven clutch member and the mounting bracket. Hold the shaft to the left, push the right-hand collar to the right to compress the spring washer, and tighten the setscrew in the right hand collar. Check related adjustment (par. 255).

253. Ribbon-Feed-Clutch Spring Adjustment (fig. 246)

a. Requirement. When the carriage is returned to the left hand margin, the teeth of the jaw clutch should slip. This prevents the ribbon from being reversed when the carriage is returned.

b. Adjustment. With the teeth of the jaw clutch engaged, loosen the setscrews in the spring collar. Position the collar approximately 1/4 inch from the back surface of the clutch drum. Tighten the setscrews and recheck the requirement (a above). If necessary, increase this clearance to insure that the clutch slips when the carriage is returned.

254. Ribbon-Reverse Beam Adjustment (fig. 247)

a. Requirement. There should be 0.0015- to

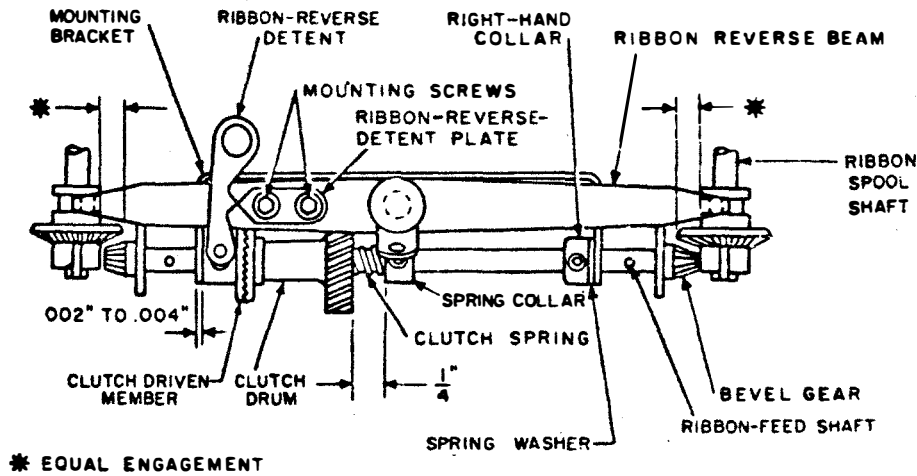

* EQUAL ENGAGEMENT

TM5815-206-35-202

Figure 246. Ribbon-spool shaft adjustment.

0.005-inch clearance between the ribbon-reverse beam and the groove in each spool bevel gear.

b. Method of Checking. Check the requirement on both sides of the ribbon-reverse beam with feeler gages.

c. Adjustment. Form the ends of the ribbon-reverse beam to meet the requirement (a above).

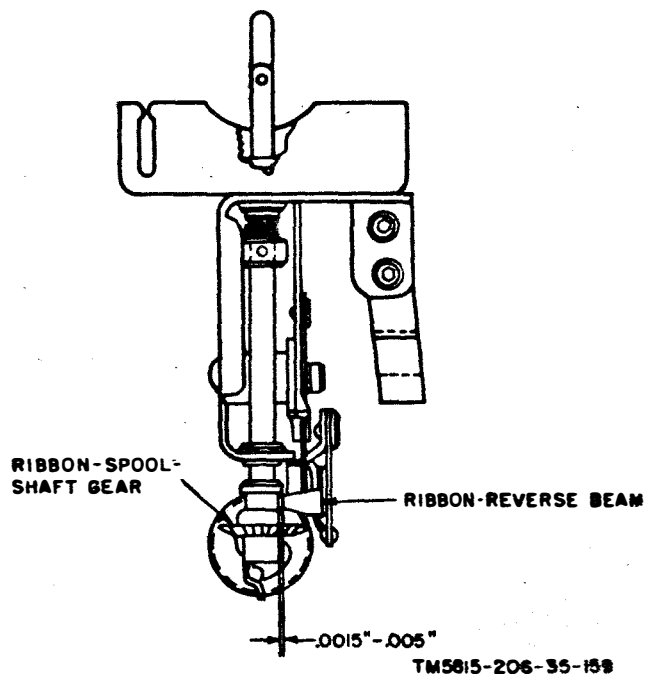

Figure 247. Ribbon-reverse beam adjustment.

255. Ribbon-Reverse Detent-Plate Adjustment (fig. 248)

a. Requirement. There should be equal engagement on each side of the ribbon-reverse-detent plate in both ribbon driving positions.

b. Method of Checking. Remove the detent spring. Position the ribbon-reverse beam so that the high points of the detent and the ribbon-reverse-detent plate meet. Clearances should be equal, or the engagement between the detent and ribbon-reverse-detent plate should be equal in both positions of the beam.

c. Adjustment. Loosen the two mounting screws of the ribbon-reverse-detent plate. Hold the ribbon-reverse-detent plate in position on the beam. Shift the beam until requirement (a above) is met. Tighten the two mounting screws. Check both latched beam positions for equal engagement.

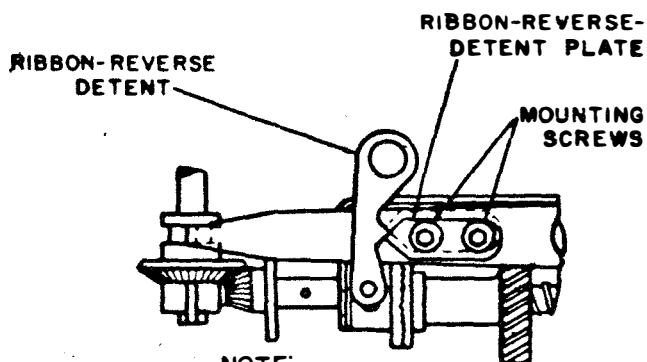

NOTE:
RIBBON-REVERSE-DETENT
SPRING REMOVED.

TM5815-206-35-267

Figure 248. Ribbon-reverse detent-plate adjustment.

256. Ribbon-Spool Driving-Collar Adjustment (fig. 249)

a. Requirement. There should be 0.010- to 0.020-inch clearance between the top of the groove in the ribbon-spool-shaft gear and the top of the key on the ribbon-spool shaft when the bevel gears are engaged. Check both sets of gears for this requirement.

b. Method of Adjustment. Engage the right hand bevel gears and check the requirement with feeler gages. Change the position of the ribbon-reverse beam to engage the left hand bevel gears and check the requirement with feeler gages.

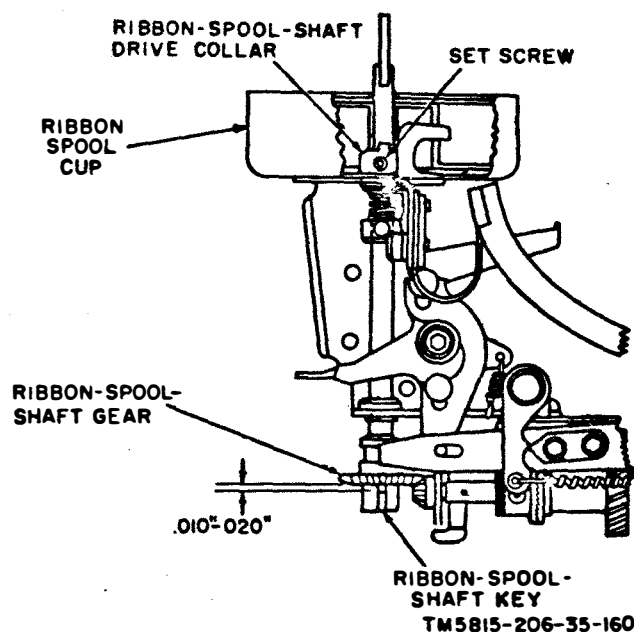

TM5815-206-35-160

Figure 249. Ribbon-spool driving-collar adjustment.

c. *Adjustment.* Remove the ribbon spool and loosen the setscrews in the ribbon-spool-shaft drive collar. Hold the collar against the ribbon-spool cup and position the shaft to meet the requirement (a above). Tighten the setscrews and recheck the requirement. Adjust the opposite spool shaft in the same manner if necessary. Replace the ribbon spools and check related adjustment (par. 257).

257. Ribbon-Spool Friction-Spring Adjustment (TT-4B/TG) (fig. 250)

a. *Requirement.* A force of 1 to 2 ounces should be required to rotate each ribbon-spool shaft when measured at the tip of the ribbon-spool lock in the lower locked position.

b. *Method of Checking.* Remove the two ribbon spools from their shafts. Position the ribbon-reverse beam to disengage the bevel gears. Check the requirement (a above) with a spring scale.

c. *Adjustment.* Loosen the setscrews in the

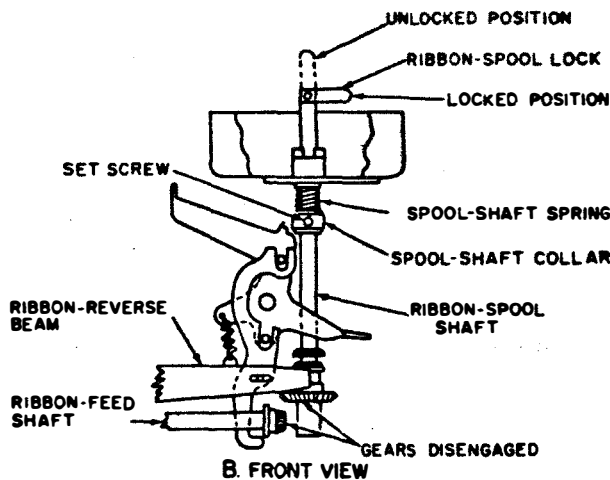
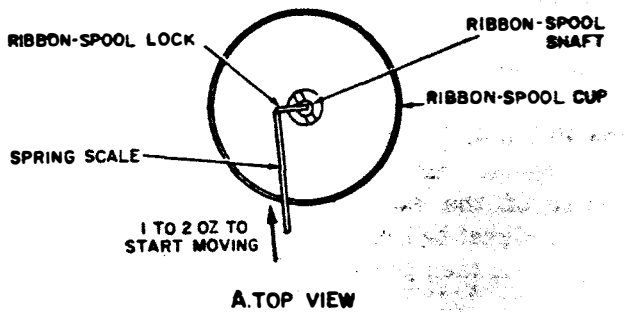

TM5815-206-35-161

Figure 250. Ribbon-spool friction-spring adjustment (TT-4B/TG).

spool-shaft collar. Position the collar up or down to meet the requirement (a above). Tighten the setscrews and recheck the requirement. Adjust the other spool-shaft collar in the same manner.

258. Ribbon-Sensing-Lever Adjustment (fig. 251)

a. *Requirement.* There should be a 0.030-inch minimum clearance between the tip of each ribbon-reverse-cam follower and the side of each ribbon-reverse cam when the ribbon-sensing lever is sensing ribbon on the ribbon spool.

b. *Method of Checking.* Disengage the bevel gears. With ribbon on the ribbon spool, turn the ribbon-spool shaft until the ribbon-reverse-cam follower is positioned as close as possible to the ribbon-reverse cam. Check the requirement (a above) with a feeler gage. Repeat on the opposite side.

c. *Adjustment.* Form the ribbon-sensing lever to meet the requirement, as shown.

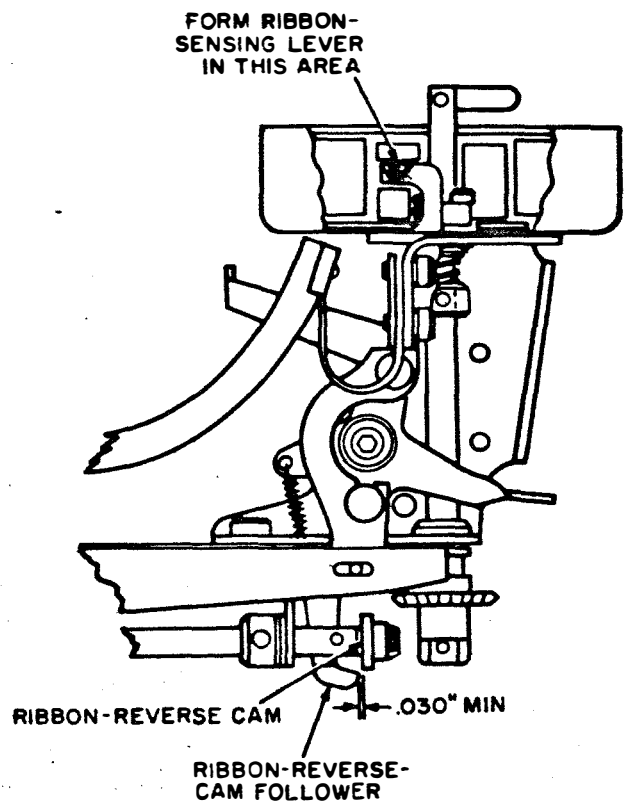

TM5815-206-35-162

Figure 251. Ribbon-sensing-lever adjustment.

259. Ribbon-Reverse Cam-Follower Adjustment (fig. 252)

a. Requirement. The tip of the ribbon-reverse-detent plate should be past the tip of the detent when the ribbon-reverse-cam follower has reached a point on the cam 0.027- to 0.057-inch from the highest point on the ribbon-reverse cam.

b. Method of Checking. Remove the ribbon spool and move the carriage support frame until the ribbon-reverse-cam follower is in the position on the ribbon-reverse cam as stated above. Check the requirement (*a* above). Check both right and left ribbon-reverse-cam followers. Replace the ribbon spool.

c. Adjustment. Bend the ribbon-reverse-cam follower to meet the requirement.

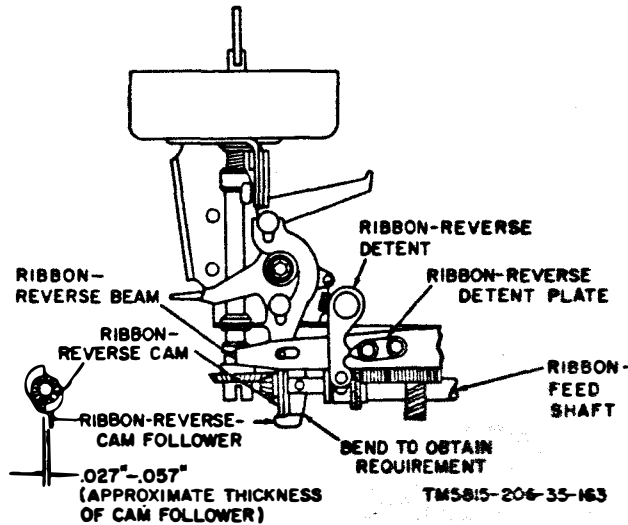

Figure 252. Ribbon-reverse cam-follower adjustment.

260. Signal-Bell Bracket Adjustment (fig. 253)

a. Requirement. The motor-stop function lever and the signal-bell clapper should move freely when the punch bars are actuated.

b. Method of Checking. Shift the platen to the figures position. Actuate the punch bars manually and check for any tightness or binding.

c. Adjustment. Loosen the two mounting screws and position the signal bracket to meet the requirement. Tighten the mounting screws and recheck the requirement (*a* above). If the levers bind in the side plate, bend the levers as necessary to remove the bind.

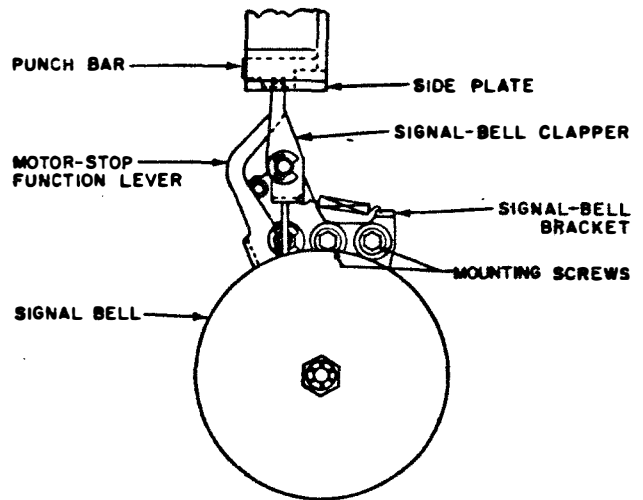

Figure 253. Signal-bell bracket adjustment.

261. Signal-Bell Preliminary Adjustment (fig. 254)

a. Requirement. The clapper stud should stop the clapper $\frac{1}{32}$ to $\frac{3}{32}$ inch from the signal bell.

b. Method of Checking. Manually move the clapper against the clapper stud. Check the clearance.

c. Adjustment. Remove the nut that holds the signal bell to the mounting stud. Position the bell so that the mounting stud is in the center of the elongated hole. Bend the rod of the signal-bell clapper to meet requirement (*a* above), then perform the signal bell adjustment (par. 262).

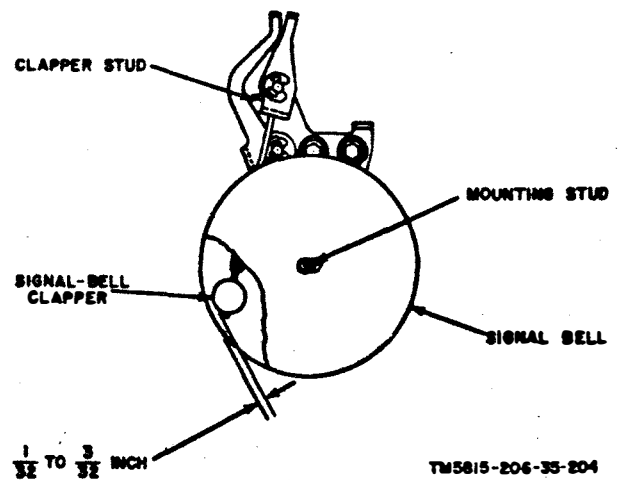

Figure 254. Signal-bell preliminary adjustment.

262. Signal-Bell Final Adjustment (fig. 255)

a. Requirements.

- (1) There should be $\frac{1}{16}$ - to $\frac{3}{32}$ -inch clearance between the signal-bell clapper and the clapper stop when the clapper is held to the right by its spring. The signal bell should not operate when the teletypewriter is operating in the letters-shift position.
- (2) The signal bell should sound loud and clear when the teletypewriter is operating in the figures position and the S code group is received.

b. Adjustments.

- (1) Remove the upper locknut and the signal bell. Loosen the lower locknut. Be sure the signal bell clapper is held to the right as far as possible by its spring. Position the clapper stop to meet the requirement.
- (2) Replace the signal bell and upper locknut. Position the signal bell to meet requirement a(2). Tighten the upper locknut.

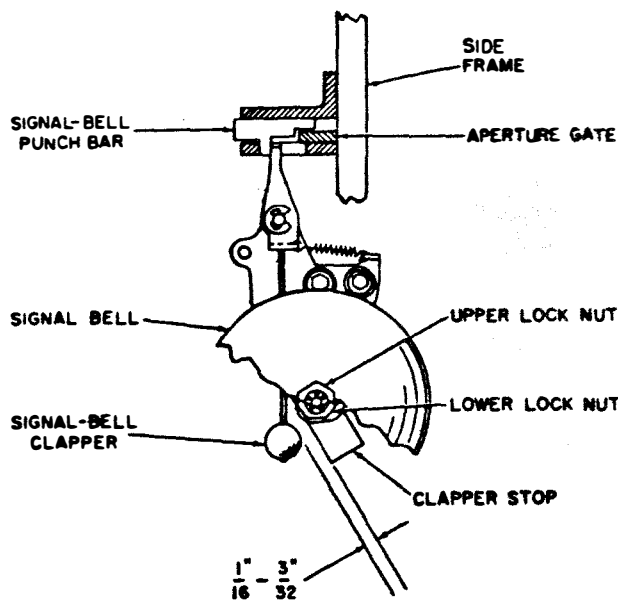

Figure 255. Signal-bell final adjustment.

263. Motor-Stop Contact-Lever Lug Adjustment (TT-4A/TG) (A, fig. 256)

a. Requirement. There should be 0.006- to

0.015-inch clearance between the motor-stop actuating lever and the contact-lever lug when the contacts are closed.

b. Adjustment. Loosen the mounting screw that holds the contact-lever lug to the contact lever. Turn the lug to meet the requirement (a above). Tighten the machine screw.

264. Motor-Stop Contacts and Eccentric Sleeves Adjustments (TT-4A/TG) (B, fig. 256)

a. Requirements.

- (1) A force of $2\frac{1}{3}$ to 3 ounces should be required to separate each pair of motor-stop contacts.
- (2) There should be a 0.005- to 0.015-inch clearance between each motor-stop spring contact and its associated eccentric sleeve.

b. Adjustments.

- (1) Use long-nosed pliers to bend the lower portion of the spring contacts to meet requirement a(1) above.
- (2) Turn the eccentric sleeves to obtain the proper clearance (a(2) above).

265. Motor-Stop Contact-Lever Spring Adjustment (TT-4B/TG) (A, fig. 257)

Note. This adjustment should be made only when the motor-stop-switch bracket is removed from the motor-stop bracket and the complete motor-stop assembly is removed from the teletypewriter.

a. Requirement.

- (1) The contact lever should not bind in the motor-stop bracket.
- (2) A force of $\frac{3}{4}$ to $1\frac{1}{4}$ ounces should be required to start the contact-lever lug moving in the direction shown.

b. Method of Checking.

- (1) Move the contact lever about its pivot pin to check the requirement (a(1) above).
- (2) Use a spring scale to check the requirement (a(2) above).

c. Adjustment.

- (1) Remove the motor-stop bracket, the pivot pin of the contact lever, and the contact lever. Check the contact lever for straightness. Also check the slot in the bracket for accumulation of dirt. Clean and lubricate the slot. Replace the contact lever and the pivot

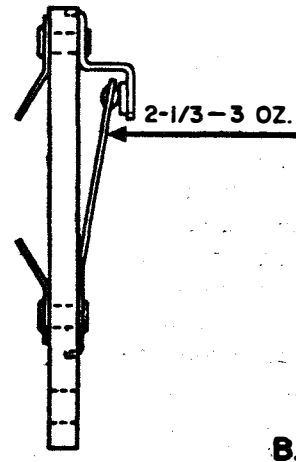
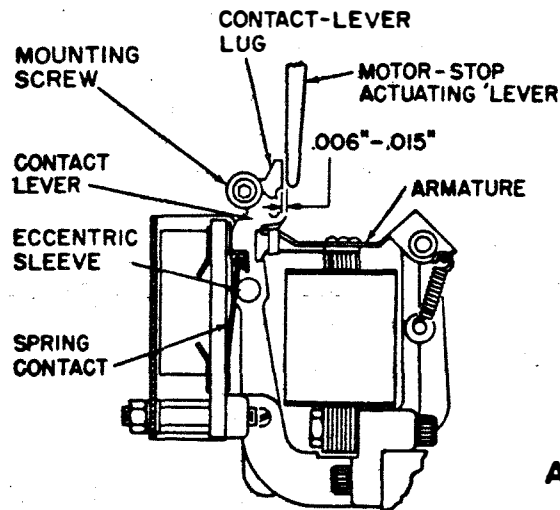

TM5815-206-35-165

Figure 256. Motor-stop contact-lever lug and relay contacts adjustments (TT-4A/TG).

pin and check the requirement (a(2) above).

- (2) Turn the spring-adjusting set screw (A, fig. 257) to obtain requirement a(2) above.

Note. The setscrew must not protrude beyond the surface of the motor-stop bracket.

266. Motor-Stop-Relay Coil Adjustment (TT-4B/TG) (B, fig. 257)

a. Requirement. There should be a clearance of 0.004- to 0.006-inch between the armature and the stop of the contact lever lug when the armature is against both pole faces.

b. Method of Checking. Move the armature against the pole faces and check requirement (a above) with feeler gages.

c. Adjustment. Loosen the coil-mounting screws and position the coils to meet the requirement (a above). Tighten the screws and recheck the requirement.

267. Motor-Stop Switches and Eccentric Sleeves Preliminary Adjustments (TT-4B/TG)

a. Requirement.

- (1) Maximum eccentricity of the eccentric sleeves should be in the direction shown in A, fig. 258.

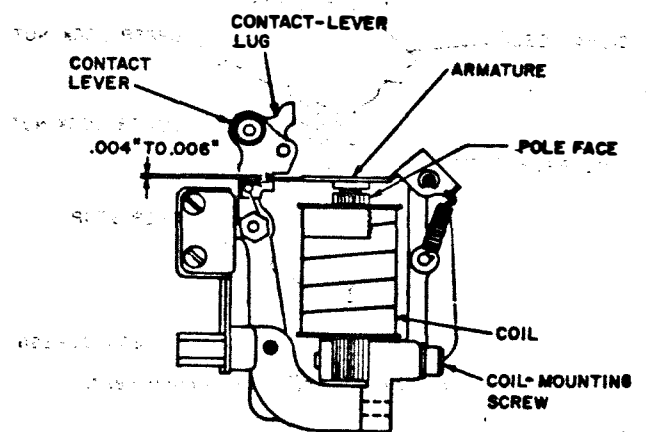
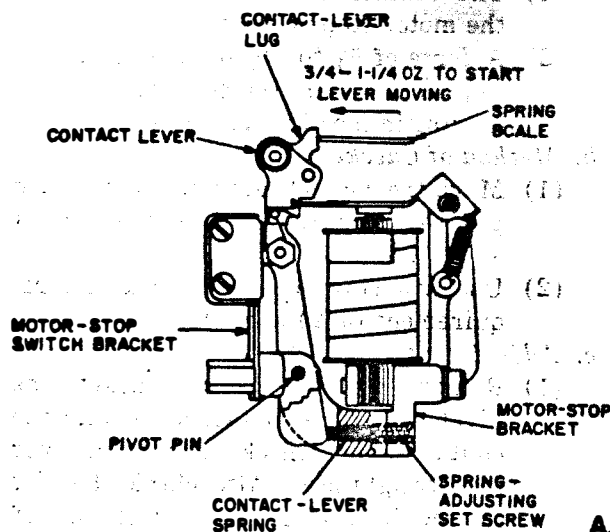

TM5815-206-35-164

Figure 257. Motor-stop contact-lever spring assembly and relay coil adjustments (TT-4B/TG).

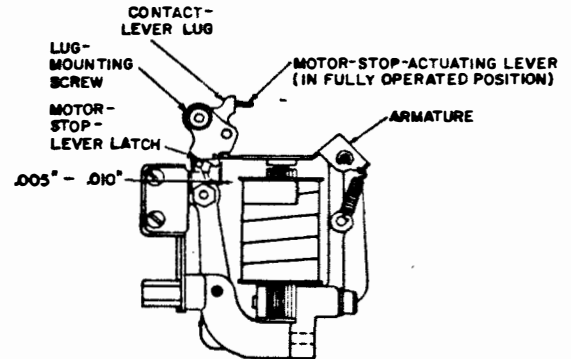
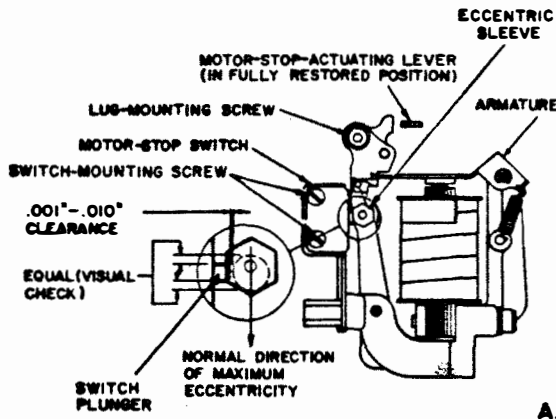

B.
TM5815-206-35-166

Figures 258. Motor-stop switches eccentric sleeves, and contact-lever lug adjustments (TT-4B/TG).

- (2) Each switch plunger should be centered with its sleeve (visual check) and a .010-inch maximum clearance should be present between the plunger and its associated sleeve when the contact lever and armature are as shown (A, fig. 258).

b. Adjustment.

- (1) Turn each eccentric sleeve to meet requirement *a*(1) above.
- (2) Loosen the switch-mounting screws and position each switch to meet requirement *a*(2) above. Tighten the screws and recheck the requirement.

268. Motor-Stop Contact-Lever Lug Adjustment (TT-4B/TG)

(B, fig. 258)

a. Requirement. There should be a .005- to 0.010-inch clearance between the armature and the latch when the contact lever is held in the fully operated position by the motor-stop actuating lever.

b. Method of Checking. Place the platen in the figures-shift position, turn the motor off, and position the Y-levers for the H code group. (No. 3 and No. 5 clockwise, No. 1, No. 2, and No. 4 counterclockwise). Trip the transfer-lever latch and turn the motor manually until the motor-stop actuating lever is in the fully operated position. Check the requirement (*a* above) with feeler gages.

c. Adjustment. Position the mechanism as described in *b* above. Loosen the lug mounting screw and position the contact-lever lug to meet

the requirement (*a* above). Tighten the lug mounting screw and recheck the requirement.

269. Motor-Stop Eccentric Sleeves Final Adjustment (TT-4B/TG)

a. Requirement. There should be a 0.001- to 0.010-inch clearance between each eccentric sleeve and its associated switch plunger when the contact-lever is in the maximum clockwise position (A, fig. 258).

b. Method of Checking. Set the contact lever to the maximum clockwise position and check the clearance between each eccentric sleeve and its associated switch plunger with a feeler gage.

c. Adjustment. Turn each eccentric sleeve in the direction required to meet the requirement.

270. Motor Gears Backlash Adjustment (TT-4B/TG)

(fig. 259)

Note. This adjustment should be made when the operating speed is changed.

a. Requirement. There should be a minimum backlash with no binding between the main-shaft driven gear and the worm gear.

b. Method of Checking. Grasp the main shaft and gently rotate the motor shaft back and forth by turning the governor target to determine the gear backlash. Check with the main shaft held in various positions.

c. Adjustment. Loosen the motor mounting screws and position the threaded portion of the sleeves flush with the frame. Position the motor to center the worm gear on the main-shaft

driven gear. Tighten the screws friction-tight. Check the requirement (a above). Loosen the motor mounting screws and turn the three sleeves until there is a minimum backlash with no binding between the main-shaft driven gear and the worm gear. Tighten the mounting screws and check the requirement (a above).

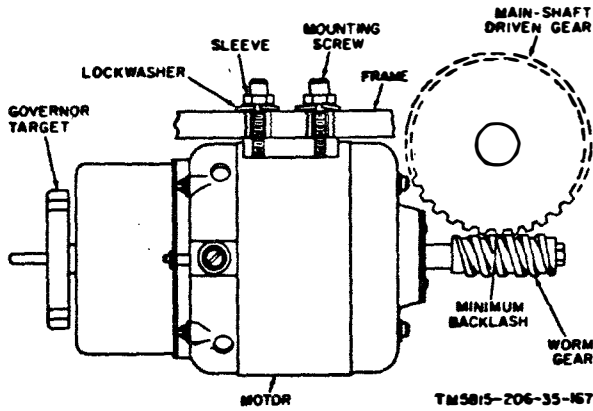

Figure 259. Motor gears backlash adjustment (TT-4B/TG).

271. Motor-Governor Contacts Alinement (fig. 260)

a. Requirements.

- (1) The contacts should be centered and adjusted for maximum area of engagement.
- (2) A force up to 8 ounces should be required to turn the speed adjustment gear at any point within the operating range of the motor.

b. Adjustment.

- (1) Loosen the mounting screw that secures the spring contact assembly and position the assembly to meet the re-

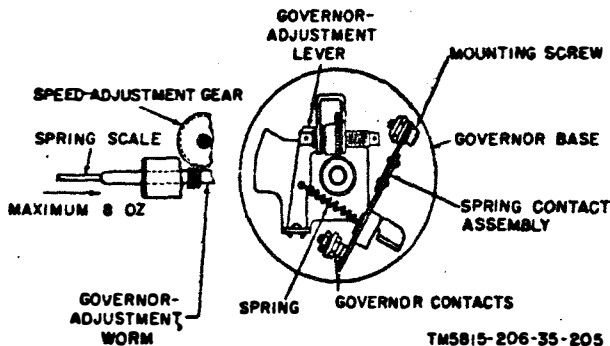

Figure 260. Motor-governor contacts alinement.

quirement (a(1) above). Tighten the mounting screw.

- (2) Check for dirt or bind between the governor adjustment worm and the speed adjustment gear to meet the requirement (a(2)) above.

272. Governor-Assembly Locating Adjustment (fig. 261)

Note. This adjustment should be performed only when mounting the governor assembly on the motor.

a. Requirement. There should be a clearance of $\frac{1}{32}$ to $\frac{3}{32}$ inch between the governor slip ring and the brush holder.

b. Adjustment. Loosen the two setscrews and position the governor assembly to meet the requirement. Tighten one setscrew fingertight. Tighten the other setscrew. This insures that the governor base is properly in line with the shaft of the motor.

Note. The governor sliprings must be clean and smooth to insure proper brush contact. The area between the slip rings must be clean and free of foreign material.

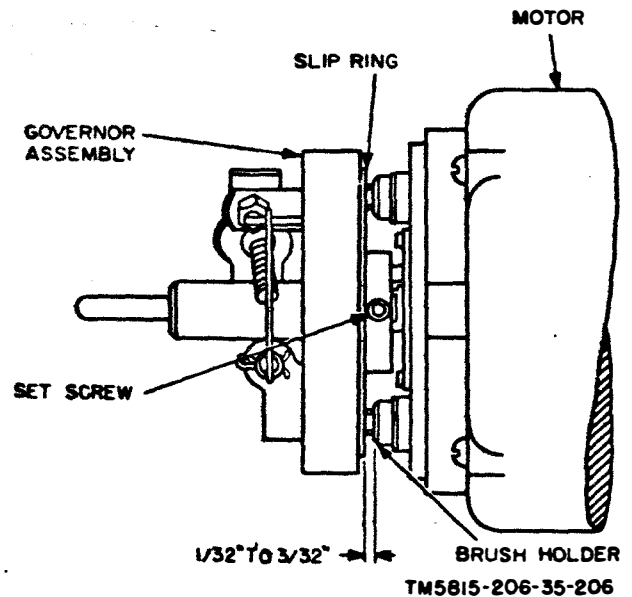

Figure 261. Governor-assembly locating adjustment.

273. Governor Target Adjustment (fig. 262)

a. Requirement. There should be a 0.020-inch maximum clearance between the governor target and the governor cover.

b. Adjustment. Loosen the setscrew and po-

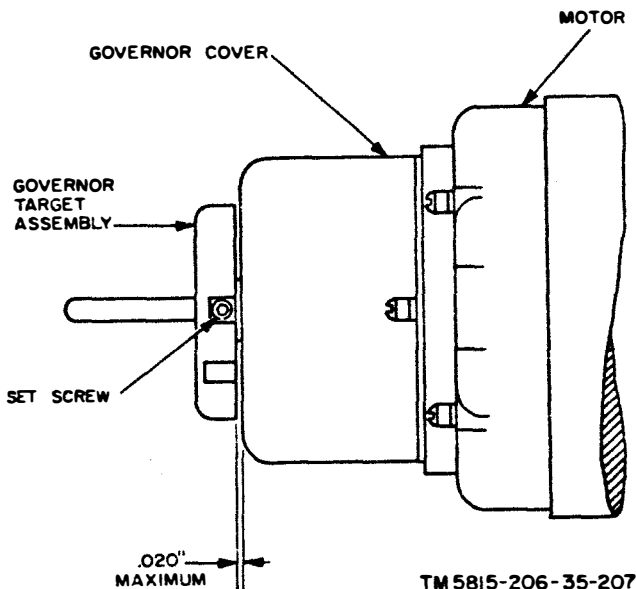

Figure 262. Governor target adjustment.

sition the governor target assembly to meet the requirement (a above). Tighten the setscrew.

274. Copy-Light Screws Adjustment (fig. 263)

a. *Requirement.* There should be $15\frac{1}{32}$ - to $17\frac{1}{32}$ -inch clearance between the bottom edge of the dust cover and the bottom of the copy-light screws.

b. *Adjustment.* Loosen the hexagonal nuts and position the copy-light screws in or out to meet the requirement (a above). Tighten the nuts and recheck the clearance.

275. Dust-Cover Cam-Lock Adjustment (TT-4B/TG) (fig. 264)

a. *Requirement.* There should be $\frac{1}{32}$ -inch

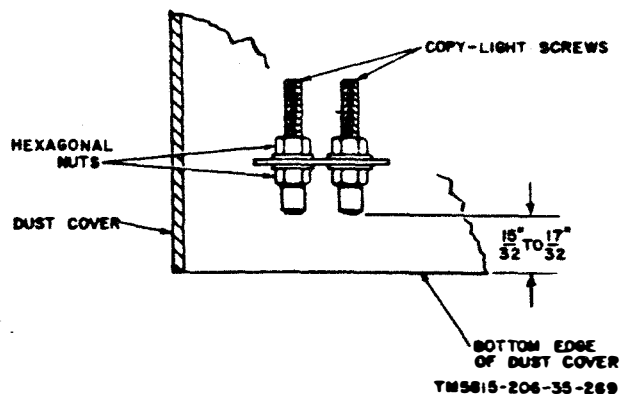

Figure 263. Copy-light screws adjustment.

clearance between the cam-lock stud and the slot in the dust cover when the dust cover is seated against the mounting base.

b. *Adjustment.* Loosen the locknut and position the eccentric post until requirement (a above) is met. Tighten the locknut and recheck the requirement.

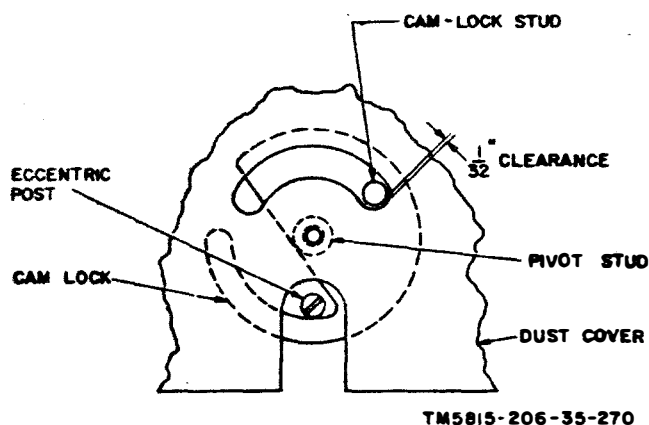

Figure 264. Dust-cover cam-lock adjustment.

Section VIII. SPRING DATA

276. General

a. This section contains data on the coil springs used in the teletypewriters. This information is useful when inspecting or overhauling to determine which springs must be replaced. It is also useful as a check list when reassembling, adjusting, or troubleshooting, and as a means of identifying springs.

b. The charts in paragraphs 277 through 280 give the dimensional and strength character-

istics required of each spring used in the teletypewriters. Each type of spring is illustrated in figures 265 through 273. The free length is measured between the inside surfaces of the end hooks. A spring that fails to pass its strength check should be replaced.

Note. In some cases, spring tensions are indicated in grams for more accurate adjustments than are possible with ounce scales. If it is necessary to convert from ounces to grams, or from grams to ounces, remember that 1 ounce equals 28.35 grams.

277. Compression Spring Data

Reference No.	Name	A Free length (in.)	B Compressed length (in.)	Required tension compressed length	C Wire thickness (in.)	D No. of coils	E Outside diameter (in.)
50154	Stop bar.....	$\frac{21}{64}$.375	13 oz \pm 3 oz.....	0.020 \pm 0.0003	10	0.183
50847	Clutch pressure.....	$\frac{1}{2}$	$\frac{9}{32}$	10 lb \pm 8.....	.053 \pm .0005	4	.453 ID
50848	Function-shaft clutch.....	$1\frac{3}{64}$	$\frac{7}{16}$	21 lb 10 oz \pm 4 oz.....	.041 \pm .0005	6	.597 ID
50859	Friction clutch.....	$\frac{5}{8}$	$\frac{5}{16}$	8 lb \pm 12 oz.....	.057 \pm .0005	$3\frac{3}{4}$.390 ID
50910	Friction plate.....	$1\frac{17}{32}$	$\frac{5}{16}$	32 oz \pm 3 oz.....	.028 \pm .0005	$6\frac{1}{2}$.250 ID
50914	Friction clutch.....	$1\frac{13}{32}$	$\frac{5}{16}$	6 lb \pm 10 oz.....	.0490 \pm .0005	4	.390 ID
50917	Function-selecting arm.....	$\frac{9}{16}$	$1\frac{13}{32}$	6 oz \pm $\frac{1}{2}$ oz.....	.0240 \pm .0005	5	.390 ID
51120	Lamp connector receptacle contact	$\frac{3}{4}$	$1\frac{17}{32}$	10 oz \pm 2 oz.....	.0320 \pm .0005	$5\frac{1}{2}$.468
52259	Carriage-return-clutch lever.....	$1\frac{17}{16}$	$1\frac{17}{32}$	6 oz \pm 1 oz.....	.0220 \pm .0003	16	.281 ID
52940	Stop bar.....	$\frac{21}{64}$.375	8 oz \pm $\frac{1}{2}$ oz.....	.0160 \pm .0005	$11\frac{1}{2}$.183
53961	Spool friction.....	$\frac{1}{2}$	$\frac{1}{4}$	20 oz \pm 4 oz.....	.0210 \pm .0003	7	.198 ID
54932	Friction clutch.....	$1\frac{13}{32}$	$\frac{1}{2}$	6 lb \pm 10 oz.....	.067 \pm .001	$3\frac{1}{2}$.6875 ID
54933	Clutch pressure.....	$\frac{1}{2}$	$\frac{9}{32}$	10 lb 8 oz \pm 12 oz.....	.067 \pm .001	$3\frac{1}{2}$.6875 ID
54934	Friction clutch.....	$\frac{3}{8}$	$\frac{5}{16}$	8 lb \pm 12 oz.....	.080 \pm .001	$3\frac{1}{2}$.6875 ID
55042	Safety clutch.....	$\frac{1}{2}$	$\frac{5}{16}$	30 lb \pm 6 lb.....	.109 \pm .005	$2\frac{1}{2}$.953 ID
56279	Square-shaft bearing.....	$1\frac{17}{32}$	$\frac{5}{16}$	32 oz \pm 3 oz.....	.028 \pm .0005	$6\frac{1}{2}$.257 ID
60607	Switch lever.....	$\frac{7}{8}$	$\frac{1}{2}$	$7\frac{1}{4}$ oz \pm 10%.....	.014 \pm .003	23	.140

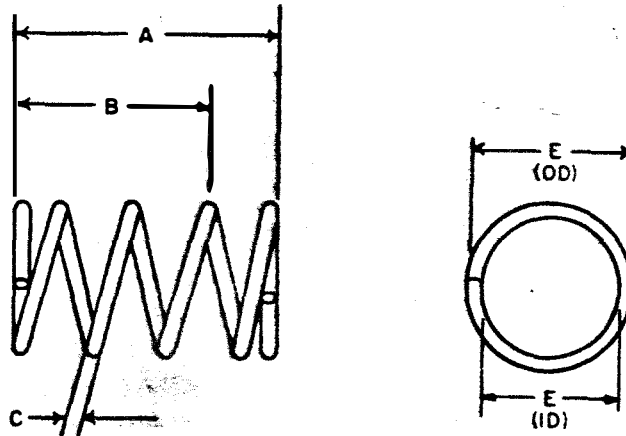

TM 5815-206-35-208

Figure 265. Compression spring.

278. Parallel-end and Random-end Spring Data (fig. 266)

Reference No.	Name	A Free length (in.)	B Extended length (in.)	Required tension extended length	C Wire thickness (in.)	D No. of coils	E Outside diameter (in.)
50231	Margin-bell clapper.....	1 1/16	3/4	8 oz ± 1 oz.....	0.016 ± 0.0003	30	0.125
50232	Margin-bell pawl.....	5/8	1 1/16	1 oz ± 1/4 oz.....	.010 ± .0003	40	.125
50333	Line-feed pawl.....	5/8	3/4	2 1/2 oz ± 1/2 oz.....	.010 ± .0003	39 1/4	.125
50575	Ribbon vibrator.....	1 1/8	1 1/8	1 1/4 oz ± 1/4 oz.....	.0100 ± .0003	88	.125
50595	Connecting bar.....	3/4	7/8	3 1/2 oz ± 1/4 oz.....	.0100 ± .0003	30	.138
50901	Line-feed and figure-shift-cam follower.	5/8	7/8	8 oz ± 1/2 oz.....	.0110 ± .0003	26	.095
50903	Transfer lever.....	1 3/16	1 1/4	5 lb 13 oz ± 3 oz.....	.042 ± .0005	14	.281
50919	Motor-stop actuating lever.....	1/2	5/8	2 1/2 oz ± 1/4 oz.....	.0110 ± .0003	25 3/4	.125
50920	Signal-bell clapper.....	2 3/16	2 7/16	1 1/2 oz ± 1/4 oz.....	.010 ± .0003	49	.125
51136	Universal code bar return.....	1 1/16	1	15-20 grams.....	.0090 ± .0003	46	.150
51544	Locking-lever latch.....	7/8	1 1/8	1 1/2 oz ± 1/4 oz.....	.010 ± .0003	57	.125
51574	Sensing-lever locking bail.....	5/8	7/16	2 1/2 oz ± 1/4 oz.....	.0120 ± .0003	31	.156
51575	Cam stop lever.....	1 3/16	1 3/8	3 oz ± 1/2 oz.....	.0120 ± .0003	43	.156
51645	Platen shift bell crank.....	1	1 1/2	8 oz ± 1 oz.....	.0160 ± .0003	46 1/2	.156
51755	Line-feed bell crank.....	1 3/16	1 3/8	28 oz ± 2 1/2 oz.....	.0230 ± .0003	27 3/4	.187
52164	Manual carriage-return trip pawl..	1 7/16	3/4	10 oz ± 10%.....	.016 ± .0003	16 1/2	.156
54943	Blank holder slide.....	3/4	5/8	2 lb ± 4 oz.....	.0220 ± .0003	9	.172

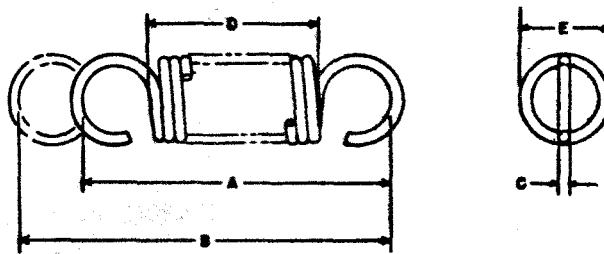

TM 5815-206-33-209

Figure 266. Parallel-end and random-end springs.

279. Crossed-end Spring Data
(fig. 267)

Reference No.	Name	A Free length (in.)	B Extended length (in.)	Required tension extended length	C Wire thickness (in.)	D No. of coils	E Outside diameter (in.)
50332	Platen detent.....	$\frac{3}{4}$	$\frac{7}{8}$	48 oz \pm 4 oz.....	0.025 \pm 0.0005	29	0.156
50334	Adjustment lever.....	$\frac{5}{16}$	1	32 oz \pm 3 oz.....	.023 \pm .0005	23 $\frac{1}{2}$.156
50403	Ribbon-reverse detent.....	1	1 $\frac{1}{4}$	5 oz \pm $\frac{3}{4}$ oz.....	.013 \pm .0003	60	.125
50447	Ribbon-sensing lever.....	$\frac{15}{32}$	$\frac{15}{32}$	2 oz \pm $\frac{1}{2}$ oz.....	.0100 \pm .0003	12	.156
50904	Transfer-lever trip latch.....	$\frac{25}{64}$	$\frac{13}{16}$	2 $\frac{1}{2}$ oz \pm $\frac{3}{4}$ oz.....	.0110 \pm .0003	15 $\frac{3}{4}$.156
50906	Carriage-return bell crank.....	$\frac{11}{16}$	$\frac{13}{16}$	4 $\frac{1}{2}$ lb \pm 6 oz.....	.034 \pm .0005	9 $\frac{1}{4}$.250
50908	Selector-magnet armature.....	1	1 $\frac{3}{16}$	8 oz \pm $\frac{1}{2}$ oz.....	.020 \pm .0005	16 $\frac{3}{4}$.190
50911	Carriage-feed-clutch lever.....	$\frac{25}{32}$	$\frac{15}{16}$	40 oz \pm 4 oz.....	.0250 \pm .0005	15 $\frac{3}{4}$.200
50912	Carriage-feed pawl.....	$\frac{1}{2}$	$\frac{21}{32}$	17 $\frac{1}{2}$ oz \pm 1 $\frac{1}{2}$ oz.....	.0180 \pm .0005	12 $\frac{3}{4}$.156
50915	Supporting lever.....	$\frac{21}{32}$	$\frac{25}{32}$	4 lb \pm 6 oz.....	.036 \pm .0008	7 $\frac{1}{4}$.250
50916	Platen latch.....	$\frac{3}{8}$	$\frac{1}{2}$	10 oz \pm 1 oz.....	.0130 \pm .0003	13 $\frac{3}{4}$.125
50921	Print-cam follower.....	$\frac{7}{8}$	1 $\frac{1}{16}$	6 $\frac{1}{2}$ lb \pm 8 oz.....	.0390 \pm .0005	11 $\frac{3}{4}$.250
50941	Key lever.....	$\frac{1}{2}$	$\frac{5}{8}$	20 oz \pm 2 oz.....	.020 \pm .0003	8 $\frac{3}{4}$.187
50942	Space bar.....	$\frac{1}{2}$	$\frac{5}{8}$	60 oz \pm 6 oz.....	.0280 \pm .0005	5 $\frac{1}{4}$.218
50944	Repeat-blocking lever.....	$\frac{3}{8}$	$\frac{3}{8}$	2 $\frac{1}{2}$ oz \pm $\frac{1}{2}$ oz.....	.0100 \pm .0003	14 $\frac{1}{4}$.125
50946	Double-blocking lever.....	$\frac{19}{32}$	$\frac{11}{16}$	28 oz \pm 3 oz.....	.0240 \pm .0003	11 $\frac{3}{4}$.1875
50965	Motor-stop armature.....	$\frac{21}{32}$	$\frac{11}{16}$	12 oz \pm 10%.....	.0160 \pm .0003	14	.152
51548	Contact bail spring.....	$\frac{7}{16}$	$\frac{9}{16}$	11 oz \pm 1 oz.....	.0150 \pm .0003	14	.125
51754	Line-feed sensing lever.....	$\frac{27}{64}$	$\frac{3}{8}$	34 oz \pm 10%.....	.0180 \pm .0003	21 $\frac{1}{4}$.125
51851	Platen-spacing detent.....	$\frac{21}{32}$	$\frac{25}{32}$	54 oz \pm 6 oz.....	.0250 \pm .0005	17 $\frac{1}{4}$.160
52169	Paper guide.....	$\frac{51}{64}$	1	34 $\frac{1}{2}$ oz \pm 10%.....	.0220 \pm .0003	24 $\frac{3}{4}$.141
52501	Platen latch.....	$\frac{25}{64}$	$\frac{1}{2}$	12 oz \pm 2 oz.....	.0140 \pm .0003	10 $\frac{3}{4}$.125
53149	Platen-lever latch.....	$\frac{25}{32}$	$\frac{7}{8}$	20 oz \pm 1 oz.....	.0200 \pm .0003	27 $\frac{1}{4}$.156
53974	Space bar.....	$\frac{1}{2}$	$\frac{5}{8}$	86 oz \pm 9 oz.....	.0310 \pm .0005	5 $\frac{3}{4}$.218
56258	Carriage-return clutch-actuating lever.....	$\frac{25}{64}$	$\frac{3}{4}$	70 oz \pm 1 oz.....	.0130 \pm .0003	7 $\frac{1}{4}$.168
61000	Y lever detent.....	$\frac{1}{2}$	1 $\frac{1}{2}$	80 g \pm 5 g.....	.0080 \pm .0003	9 $\frac{1}{4}$.083

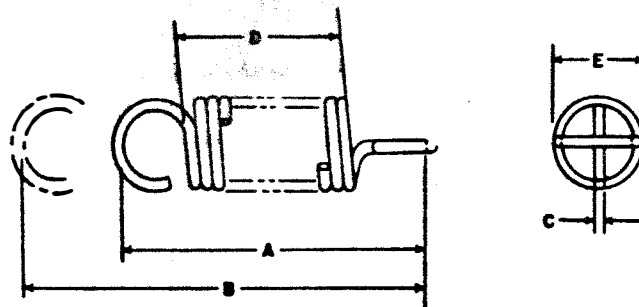

TM5815-206-35-210

Figure 267. Crossed-End springs.

280. Special Spring Data

Fig. No.	Reference No.	Name	A Free length (in.)	B Working length (in.)	Required tension extended length	C Wire thickness (in.)	No. of coils	E Diameter (in.)
268	50902	Selector lever.....	1	1¼ (extended)	8 oz ± 1 oz...	0.0120 ± 0.0003	55	0.685 OD
269	51855	Governor worm.....	¾	.047 (compressed)0140 ± .0003	6 ± ½	
270	54967	Platen trough.....	1¾	027	43½	179 ID
271	56688	Keybar bail.....	¾	028 ± .001	12	156 ID
272	57749	Code-ring locking bail0400 ± .0005	2	1½ ID
273	60625	Armature latch.....		0100 ± .0003		

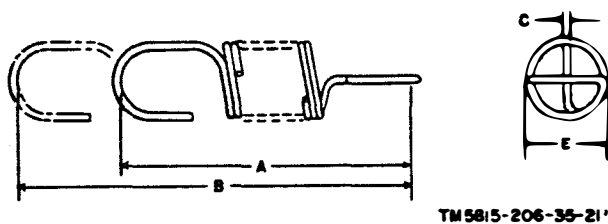

Figure 268. Selector-lever spring.

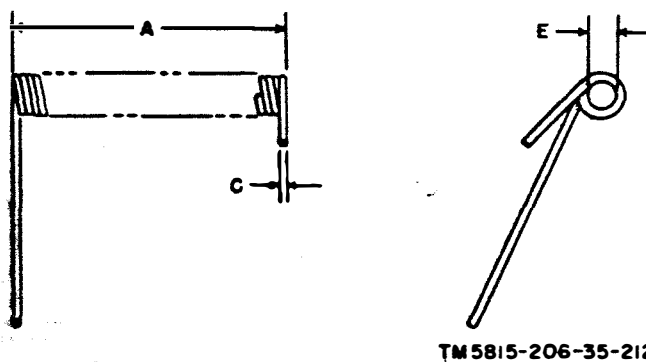

Figure 270. Platen trough spring.

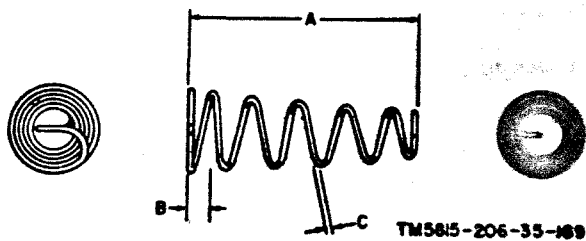

Figure 269. Governor worm spring.

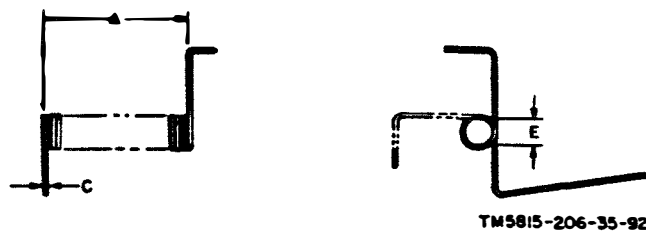
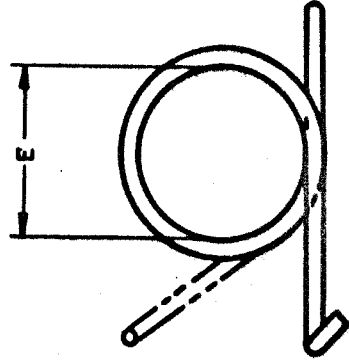
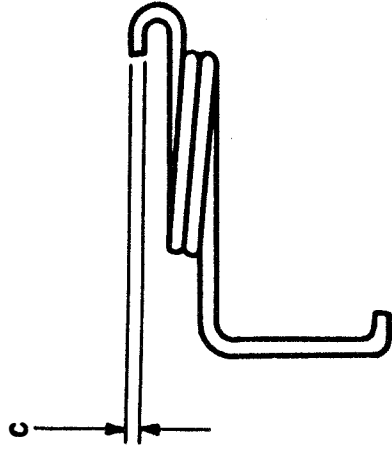
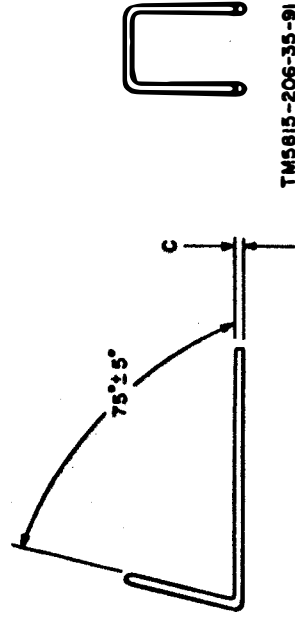

Figure 271. Keybar bail spring.



TM5815-206-35-93

Figure 272. Code-ring locking ball spring.



TM5815-206-35-91

Figure 273. Armature latch spring.

CHAPTER 4

FINAL TESTING

281. Purpose of Final Testing

The teletypewriter set must be tested thoroughly to insure that it meets all performance requirements after repair. The tests described in this chapter are used to measure the performance of the repaired teletypewriters.

282. Test Equipment Required for Final Testing

The test equipment required for final testing is the same as that listed for maintenance in the chart in paragraph 41. Refer to the technical manual indicated in the chart for specific instructions on operation of the test equipment.

283. Insulation Resistance Test

Disconnect all external teletypewriter connections and move the shorting bars to position where none of the line terminals are shorted. Turn the motor and light switches to ON. Connect the ground lead of Ohmmeter ZM-21/U to an unpainted portion of the teletypewriter base. Connect the line lead of the ohmmeter, in turn, to each of the following terminals and operate the ohmmeter as described in TM 11-2050A. A minimum insulation resistance reading of 8 megohms should be obtained with each test.

- a. Line terminals 4 through 5.
- b. Both terminals of plug P3.
- c. Both terminals of plug P1.

284. Preparation for Sending and Receiving Tests

Disconnect all external leads from the line terminals on the left hand side of the teletypewriter. Connect the teletypewriter motor power cable to a 105- to 125-volt ac power supply. Ground the braided metal pigtail at

the plug end of this cable. Set the LINE INCREASE knob to its extreme counterclockwise position. Disconnect the shorting bar from line terminal 6 and connect a 105- to 125-volt dc power supply to line terminals 5 and 6 (positive polarity to terminal 6). Connect a shorting bar across line terminals 2 and 3. Unlock the platen, carriage, and keyboard. Install paper and ribbon.

285. Preliminary Sending and Receiving Tests

- a. Connect a shorting strap between line terminals 1 and 4.
- b. Set the LINE switch to the VOICE FREQ LINE position.
- c. Adjust the LINE INCREASE knob to obtain a reading of exactly 20 on the D.C. MILLIAMPERES scale.
- d. Turn the MOTOR switch to ON and adjust the motor speed (par. 16, TM 11-5815-206-12).
- e. Alternately press the R and Y keylevers of the teletypewriter under test and adjust the ARMATURE and RANGE dials (par. 25, TM 11-5815-206-12).
- f. Make the equipment performance checks listed in paragraph 39, TM 11-5815-206-12. Repeat the test message (par. 26b, TM 11-5815-206-12) at least five times. No mistakes should appear in the printed copy, and all non-printing operations of the teletypewriter must perform perfectly.
- g. Turn the LINE switch to the D. C. LINE position.
- h. Adjust the LINE INCREASE knob to obtain a reading of exactly 60 on the D. C. MILLIAMPERES scale.
- i. Repeat the performance tests (f above).
- j. Disconnect the shorting strap between line terminals 1 and 4.

286. Final Receiving Tests

a. Preparation.

- (1) Connect Distortion Test Set TS-383A/GG to an ac and a dc power source (TM 11-2217).
- (2) Connect a pair of wires from the SIGNAL LINE cord of the distortion test set to line terminals 1 and 4 on the teletypewriter.
- (3) Set the LINE switch to the D. C. LINE position.
- (4) Adjust the LINE INCREASE knob to obtain a reading of exactly 60 on the D.C. MILLIAMPERES scale.
- (5) Turn the teletypewriter MOTOR switch to ON.
- (6) Turn the distortion test set motor switch to ON.

b. Sixty-Milliampere Bias Test.

- (1) Send the TEST MESSAGE signals from the distortion test set with *marking bias* (35 percent bias for 60-wpm operation and 30 percent bias for 100-wpm operation).
- (2) Check and, if necessary, adjust the speed of the teletypewriter motor and the distortion test set motor.
- (2) Turn the RANGE dial slowly toward 120 to find the upper limit of the RANGE dial setting at which perfect copy is printed. Record the upper limit.
- (3) Send TEST MESSAGE signals from the distortion test set with *spacing bias* (35 percent bias for 60-wpm operation and 30 percent bias for 100-wpm operation).
- (4) Turn the RANGE dial slowly toward 0 to find the lower limit of the RANGE dial setting at which perfect copy is printed. Record the lower limit.
- (5) Use the applicable formula below to compute the bias tolerance of the teletypewriter page printer.

$$(a) \text{ Bias tolerance (60-wpm operation) } = 35 + \frac{\text{(upper limit marking bias)} - \text{(lower limit, spacing bias)}}{2}$$

$$(b) \text{ Bias tolerance (100-wpm operation) } = 30 + \frac{\text{(upper limit marking bias)} - \text{(lower limit, spacing bias)}}{2}$$

- (6) The minimum permissible bias tolerance, as computed in (5) above, is 40 percent for 60-wpm operation and 35 percent for 100-wpm operation. If the bias tolerance of the page printer is less than the permissible minimum, check the adjustment of the page printer (par. 151 through 186).

c. Sixty-Milliampere End Distortion Test.

- (1) Send the TEST MESSAGE signals from the distortion test set with *spacing end distortion* (35 percent for 60-wpm operation and 30 percent for 100-wpm operation).
- (2) Turn the RANGE dial slowly toward 120 to find the upper limit of the RANGE dial setting at which perfect copy is printed. Record the upper limit.
- (3) Send TEST MESSAGE signals from the distortion test set with *marking end distortion* (35 percent for 60-wpm operation and 30 percent for 100-wpm operation).
- (4) Turn the RANGE dial slowly toward 0 to find the lower limit of the RANGE dial setting at which perfect copy is printed. Record the lower limit.
- (5) Use the applicable formula below to compute the end distortion tolerance of the teletypewriter page printer.

$$(a) \text{ End distortion tolerance (60-wpm operation) } = 35 + \frac{\text{(upper limit, spacing end distortion)} - \text{(lower limit, marking end distortion)}}{2}$$

$$(b) \text{ End distortion tolerance (100-wpm operation) } = 30 + \frac{\text{(upper limit, spacing end distortion)} - \text{(lower limit, marking end distortion)}}{2}$$

- (6) The minimum permissible end distortion tolerance, as computed in (5) above, is 35 percent for 60-wpm operation and 30 percent for 100-wpm operation. If the end distortion tolerance of the page printer is less than the permissible minimum, check the adjustment of the page printer (par. 151 through 186).

d. Range Orientation Test and Adjustment.

- (1) Send unbiased and undistorted TEST

MESSAGE signals from the distortion test set.

- (2) Turn the RANGE dial slowly clockwise and then counterclockwise to find the highest and lowest positions of the dial at which the test message is printed without error. Record both readings.
- (3) Subtract the lower reading from the high reading obtained in (2) above. The minimum permissible difference is 72 for 60-wpm operation and 60 at 100-wpm operation. Set the RANGE dial midway between the high and low readings obtained in (2) above). If the difference between the highest and lowest readings is less than 72, check the adjustment of the page printer (par. 151 through 186).

e. Twenty-Milliampere Bias and End Distortion Tests.

- (1) Set the LINE switch to the VOICE FREQ LINE position.
- (2) Adjust the LINE INCREASE knob to obtain a reading of exactly 20 on the D.C. MILLIAMPERES meter.
- (3) Check the teletypewriter RANGE dial; it should be set to the position determined in *d*(3) above.
- (4) Repeat the procedure described in *d* above, but adjust the ARMATURE dial instead of the RANGE dial. Set the ARMATURE dial halfway be-

tween the highest and lowest good-copy positions of the dial.

- (5) Repeat the procedures described in *b* and *c* above.

287. Final Sending Tests

a. Disconnect the shorting bar from line terminal 2 on the teletypewriter.

b. Set the LINE switch to the D. C. LINE position.

c. Connect a pair of wires from line terminals 1 and 2 on the teletypewriter to the STROBOSCOPE cord of the distortion test set.

d. Adjust the LINE INCREASE knob to obtain a reading of exactly 60 on the D.C. MILLIAMPERES scale.

e. Connect the distortion test set to power; set the controls on the test set; and test the quality of impulses transmitted from the keyboard-transmitter as described in TM 11-2217.

Note. To transmit a code group repeatedly from the keyboard-transmitter, hold the selected keylever in the fully depressed position and the repeat-blocking lever (fig. 12) in the clockwise position.

f. The maximum permissible deviation from perfect impulse length is ± 5 percent. Maximum tolerance for the *start* impulse and the *five code* impulses is ± 5 scale divisions on the test set (100 scale divisions equal 100 percent of perfect *code* impulse and *start* impulse length). Maximum tolerance for the *stop* impulse is ± 7 scale divisions on the test set. If the length of the transmitted impulses exceeds the maximum tolerance, check the adjustment of the keyboard transmitter (par. 136 through 149).

**APPENDIX
REFERENCES**

The following publications are applicable to field and depot maintenance of Teletypewriter Set AN/PGC-1 and Teletypewriters TT-4A/TG and TT-4B/TG.

TM 11-2050A Ohmmeter ZM-21/U.
TM 11-2208 Test Sets TS-2/TG, TS-2A/-TG, TS-2B/TG, and TS-2C/-

TG (Teletypewriter Signal Distortion).
TM 11-2217 Distortion Test Sets TS-383/-GG, TS-383A/GG, and TS-383B/GG.
TM 11-5500 Multimeter TS-297/U.

GLOSSARY

Bias tolerance. A computed measurement of the ability of a teletypewriter receiving mechanism to operate properly while receiving teletypewriter code groups that contain signal bias.

End distortion. Signal distortion which affects the *end* of marking code impulses (mark-to-space transitions) with respect to the *beginning* of the start impulse.

End distortion tolerance. A computed measurement of the ability of a teletypewriter receiving mechanism to operate properly while receiving teletypewriter code groups that contain end distortion.

Internal bias. A computed measurement of the effect of maladjustment, wear, or other mechanical fault in a teletypewriter receiving mechanism. It is used as a measure of the mechanical efficiency of the receiving unit.

Marking bias. Signal distortion which *advances* the *beginning* of marking code im-

pulses (space-to-mark transitions) with respect to the *beginning* of the start impulse.

Marking end distortion. Signal distortion which *delays* the *end* of marking code impulses (mark-to-space transitions) with respect to the *beginning* of the start impulse.

Signal bias. Distortion in the teletypewriter signals which affects the *beginning* of marking code impulses (space-to-mark transitions) with respect to the *beginning* of the start impulse.

Spacing bias. Signal distortion which *delays* the *beginning* of marking code impulses (space-to-mark transitions) with respect to the *beginning* of the start impulse.

Spacing end distortion. Signal distortion which *advances* the *end* of marking code impulses (mark-to-space transitions) with respect to the *beginning* of the start impulse.

Zero bias. A term used to indicate that no bias or distortion is present in teletypewriter signals.

INDEX

	Paragraph	Page		Paragraph	Page
Adjustments:			Adjustments—Continued		
Angular relationship of function-shaft parts	192	196	Function-cam	193	197
Armature lower-stop-screw	184	192	Function-lever-bracket	188	194
Armature upper-stop-screw	183	192	Function punch-bar and side-plate	187	194
Ball bearing	207	203	Function sensing-levers end-play	151	179
Cam-followers and spacing-collar	156	181	Function-shaft:		
Cam-stop lever-latch end-play	138	174	Clutch	170	186
Carriage:			Clearance	168	186
Positioning	206	203	Coupling	191	195
Rack	208	203	Latch	169	186
Rack drive-shaft	209	204	Tension	190	195
Rear-support bracket	223	210	Driven gear end-play	152	179
Carriage feed:			Drive-collar	155	176
Blocking adjusting lever and return blocking-lever clearance	210	204	Governor:		
Blocking-lever	212	205	Assembly, locating	272	230
Clutch drum	202	201	Target	273	230
Driven gear	197	198	Keylever-locking-bar	136	173
Driving gear end-play	196	198	Letters-shift:		
Friction-clutch	219	208	Lever shaft end-play	189	194
Pawl	198	199	Position	238, 239	217
Ratchet	194	198	Line-feed:		
Shaft drive-collar	195	198	Bell-crank	244	219
Carriage-return:			Connecting-link	245, 246	220
Adjusting-plate	214	206	Detent	243	219
Blocking-lever	211	205	Lower-stop-screw, armature	184	192
Clutch	201, 216	200, 207	Manual carriage return:		
Clutch actuating-lever	200	200	Bracket	248	221
Clutch-lever shaft clearance	199	199	Trip-pawl	249, 250	222
Friction-clutch	220	208	Margin-bell and bracket	247	220
Latch-tripping-arm	204, 218	202, 207	Motor gears backlash	270	229
Link	217	207	Motor-stop:		
Character density	235	216	Contact-lever lug	263, 268	227, 229
Code-ring:			Eccentric sleeves final	269	229
Cage	150, 151	178, 179	Contact-lever spring	265	227
Locking bail	160	182	Contacts and eccentric sleeves	264	227
Locking-bail cam follower	158	181	Motor-stop-relay:		
Locking-bail shaft	159	182	Coil	266	228
Code rings and locking-bail cam-follower-lever end-play	150	178	Switches preliminary	267	228
Copy-light screws	274	231	Orientation lever	177	189
Decelerating cam and carriage-feed-clutch positioning	203	201	Paper-guide alinement	231	214
Dust-cover cam-lock	275	231	Platen:		
Figures-shift position	237	217	Assembly end-play and positioning	234	215
Figures-shift preliminary	236	216	Blocking-arm	241	218
Fulcrum	221	209	Blocking-arm bracket	242	219
			Pressure-roller	232	214
			Pressure-rollers	233	215
			Shaft end-play	229	214

	Paragraph	Page
Adjustments—Continued		
Platen-shift final	240	218
Platen-trough:		
End-play	230	214
Spring	228	213
Print-bail and ribbon-lifter	227	212
Print-bail-blade	226	212
Rangefinder shaft	176	189
Repeat-blocking-lever	140	174
Ribbon:		
Feed-clutch spring	253	223
Feed mounting	251	223
Reverse beam	254	223
Reverse cam-follower	259	226
Reverse detent-plate	255	224
Sensing-lever	258	225
Ribbon spool:		
Driving-collar	256	224
Friction-spring	257	225
Shaft	252	223
Right-margin stopscrew	213	206
Selector friction-clutch	174, 175	188
Selector-lever	178	189
Selector-lever comb	179	189
Selector-levers and sensing-levers clearance	142	175
Selector-levers end-play	143	175
Selector-magnet	185	193
Armature	180, 181	190, 191
Armature and selector-lever clearance	186	193
Sensing-lever locking-bail	144	176
Sensing-levers alignment and end-play	141	175
Signal-bell final	262	227
Signal-bell bracket	260	226
Signal-bell preliminary	261	226
Square-shaft driven-gear	222	209
Square-shaft sliding-gear bearing	205	202
Square-shaft stop-arm torque	225	211
Start-stop selector-lever-latch	148	177
Stop-lever	182	191
Throw-out lever	215	206
T-lever pivot stud	166	184
T-lever alinement	161	183
Transfer-lever:		
Roller-stud	163	183
Shaft end-play	162	183
Spring tension	164	184
Transmitter:		
Camshaft end-play	137	173
Contact	147	177
Friction-clutch	145, 146	176
Impulse length	149	178
Type-selecting-arm and function-selecting-arm	224	210
Universal-bar	139	174
V-lever:		
Detent and v-lever	172	187
Detent end-play	171	187
Eccentric stop, preliminary	165	184

	Paragraph	Page
Adjustments—Continued		
v-lever—Continued		
Friction	173	187
Stud bracket	167	185
Armature-spring mechanism	19	16
Ballbearing adjustment	207	203
Bell, margin, theory	25	33
Bell, signal, theory	31	42
Block diagram, TT-4(°)/TG	5	5
Cam-follower and spacing-collar adjustment	156	181
Camshaft:		
Keyboard-transmitter	9	8
Transmitter, stopping and starting	12	10
Carriage:		
Frame, disassembly and reassembly	85	108
Positioning adjustment	206	203
Rear-support bracket adjustment	223	210
Removal and replacement	63	80
Carriage-feed:		
Adjustment:		
Blocking adjusting lever and carriage-return blocking-lever clearance	210	204
Blocking-lever	212	205
Clutch and decelerating cam positioning	203	201
Driven gear	197	198
Driving gear end-play	196	198
Friction-clutch	219	208
Clutch drum	202	201
Pawl	198	199
Mechanism, disassembly and reassembly	109, 110	140, 143
Operation	23	25
Shaft:		
Assembly, disassembly and reassembly	117	149
Assembly, removal and replacement	116	148
Drive-collar adjustment	195	198
Ratchet adjustment	194	198
Carriage-rack:		
Adjustment	208	203
Drive-shaft assembly, disassembly and reassembly	114	146
Drive-shaft position adjustment	209	204
Carriage-return:		
Adjustment:		
Adjusting-plate	214	206
Blocking-lever	211	205
Clutch	201, 216	200, 207
Clutch-actuating-lever	200	200
Clutch-lever-shaft clearance	199	199
Friction-clutch	220	208
Latch-tripping arm	204, 218	202, 207
Link	217	207

	Paragraph	Page
Carriage-return—Continued		
Operating mechanism, disassembly and reassembly	112, 113	144, 145
Operating mechanism, removal and replacement	111	144
Operation	24	28
Friction-clutch	24	28
Adjustment	220	208
Assembly, disassembly and reassembly	120	153
Shaft assembly, disassembly and reassembly	118, 119	149, 152
Character density adjustment	235	216
Charts, troubleshooting	55	73
Circuits:		
Motor and copylight	37	49
Receive	36	49
Send	35	47
Cleaning instructions:		
General	43	55
Special	44	55
Clutch, carriage-return, friction	24	28
Code:		
Bars and keylevers, disassembly and reassembly	70	85
Impulses, recording	19	16
Signaling	4	5
Code ring:		
Cage adjustment	150, 151	178, 179
Cage, disassembly and reassembly	105, 106	135
Cam-follower locking lever and code rings end-play adjustment	150	178
Locking-bail:		
Adjustment	160	182
Cam-follower adjustment	158	181
Shaft adjustment	159	182
Compression spring data	277	232
Copy-light screws adjustment	274	231
Crossed-end spring data	279	234
Dc circuits	35, 36, 37	47, 49
Decelerating cam and carriage-feed-clutch positioning adjustment	203	201
Differences in models	2	2
Disassembly and reassembly:		
Carriage-feed mechanism	109, 110	140, 143
Carriage-feed shaft	117	149
Carriage frame assembly	85	108
Carriage-rack drive-shaft assembly	114	146
Carriage-return:		
Clutch assembly	120	153
Operating mechanism	112, 113	144, 145
Shaft assembly	118, 119	149, 152
Code bars and keylevers	70	85
Code-ring cage	106	135
Dust cover	131	165
Function-selecting mechanism	94	119
Function sensing-lever group	107	138
Function-shaft assembly	99	129
Governor	75	95

	Paragraph	Page
Disassembly and reassembly—Continued		
Immersionproof cover	133	167
Instrument panel	73	90
Keyboard transmitter:		
Camshaft locking mechanism	71	87
Drive shaft assembly	121	153
Sensing and selector levers	69	84
Keylevers and code bars	70	85
Line-feed and platen-shift mechanisms	95, 96	123
Line terminal board	129	163
Main shaft assembly	101, 103	131, 133
Manual carriage-return mechanism	108	140
Margin-bell assembly	115	148
Motor	74	93
Motor stop assembly	123, 125	157, 158
Motor filter box assembly	128	161
Mounting base	132	167
Paper shaft, paper-shaft brackets, and paper chute	126	160
Platen:		
Frame assembly	76	95
Trough assembly	77, 78	97, 100
Print-bail shaft assembly	92	118
Rangefinder	88	112
Ribbon-feed mechanism	83	103
Ribbon lifter assembly	81, 82	101, 103
Selector camshaft assembly	100	130
Selector levers and Y-levers	89, 90	113
Selector magnet assembly	86	108
Signal-bell assembly	93	119
Square-shaft assembly	97	126
Teletypewriter frame assembly	130	164
Transfer-lever shaft assembly	91	116
Transmitter camshaft and filter	72	87
Transmitter contact assembly	68	83
Type-bar group	84	106
Type-selecting arm	80	101
Y-levers and selector levers	89, 90	113
Dust cover:		
Cam lock adjustment	275	231
Disassembly and reassembly	131	165
Removal and replacement	57	77
Electrical troubles, localizing	53	71
Equipment:		
Shop	40	54
Test	41	54
Feed:		
Carriage, operation	23	25
Line, operation	28	37
Figures-shift:		
Cam alignment	153, 154	180
Operation	26	33
Position adjustment	237	217
Final receiving tests	286	238
Final sending tests	287	239
Final testing:		
Purpose	281	237
Test equipment required	282	237

Page		Paragraph	Page		Paragraph	Page
	Forms, preventive maintenance	42	55	Keyboard transmitter—Continued		
167	Fulcrum adjustment	221	209	Camshaft locking mechanism, disassembly and reassembly ...	71	87
90	Function cam:			Drive shaft, disassembly and reassembly	121	153
	Adjustment	193	197	Impulse length adjustment	149	178
87	Function lever bracket positioning adjustment	188	194	Operation, general	9	8
153	Function punch-bar and side-plate adjustment	187	194	Removal and replacement	61	79
84	Function-selecting-arm:			Selector and sensing levers, disassembly and reassembly ...	69	84
85	And type-selecting-arm adjustments	224	210	Sensing and selector levers, disassembly and reassembly ...	69	84
123	Function-selecting mechanism, disassembly and reassembly	94	119	Keylever-locking-bar adjustment	136	173
163	Function sensing-levers:			Keylevers and code bars, disassembly and reassembly	70	85
1, 133	Disassembly and reassembly	107	138	Letters-shift:		
140	End-play adjustment	151	179	Lever shaft end-play adjustment	189	194
148	Function shaft:			Operation	27	36
93	Angular relationship of parts	192	196	Position adjustment	238, 239	217
7, 158	Clutch:			Lever adjustment, orientation	177	189
161	Clearance adjustment	168	186	Line-feed:		
167	Coupling adjustment	191	195	Adjustment	246	220
160	Eccentric post adjustment	170	186	And platen-shift mechanism, disassembly and reassembly ...	95, 96	123
95	Latch adjustment	169	186	Bell-crank adjustment	244	219
7, 100	Tension adjustment	190	195	Connecting-link adjustment	245	220
118	Disassembly and reassembly	99	129	Detent adjustment	243	219
112	Driven gear end-play adjustment	152	179	Operation	28	37
103	Drive-collar adjustment	155	180	Line terminal board:		
1, 103	Operation	20	19	Disassembly and reassembly	129	163
130	Removal and replacement	98	126	Removal and replacement	64	81
100	Functions, function cam and function-selecting arm	23	25	Localizing troubles:		
119	General:			Electrical	53	71
126	Circuit descriptions	34	47	Mechanical	54	73
164	Disassembly procedure	66	82	Lower-stop-screw armature, adjustment	184	192
116	Reassembly procedure	67	83	Lubricants:		
87	Removal and replacement	56	76	Methods of applying	49	60
83	Spring data	276	231	Recommended	46	59
106	Troubleshooting	51	71	Lubrication:		
101	Governor:			Detailed instructions	50	60
113	Assembly locating adjustment	272	230	Preparation for	48	60
231	Disassembly and reassembly	75	95	Main shaft assembly:		
165	Target assembly adjustment	273	230	Disassembly and reassembly	101, 103	131, 133
77	TT-4(*)/TG	7	6	Removal and replacement	102	132
71	Immersionproof cover, disassembly and reassembly	133	167	Maintenance instructions	38	54
54	Impulses, recording code	19	16	Manual carriage-return:		
54	Inking ribbon, operation:			Bracket adjustment	248	221
	Feeding	29	40	Mechanism, disassembly and reassembly	108	140
25	Lifting	30	41	Trip-pawl adjustment	249, 250	222
37	Reversing	29	40	Margin bell:		
180	Instructions:			And bracket adjustment	247	220
33	Detailed lubrication	50	60	Assembly, disassembly and reassembly	115	148
217	General cleaning	43	55	Operation	25	33
238	Special cleaning	44	55	Mechanical power distribution	6	5
239	Instrument panel:			Mechanical troubles, localizing	54	73
	Disassembly and reassembly	73	90	Mechanism:		
	Removal and replacement	65	81	Armature-spring	19	16
237	Keyboard-transmitter:					
	Camshaft	11	8			

	Paragraph	Page		Paragraph	Page
Mechanism—Continued			Paper shaft, paper-shaft bracket, and paper chute—		
Figures-shift	26	33	Continued		
Function shaft	20	19	Removal and replacement	58	77
Letters-shift	27	36	Parallel-end and random-end spring		
Rangefinder	19	16	data	278	233
Transmitting	9	8	Performance test	284	237
Methods of applying lubricants	49	60	Platen:		
Models, differences	2	2	Adjustment:		
Motor:			Assembly end-play and		
Disassembly and reassembly	74	93	positioning	234	215
Filter box assembly, removal and			Blocking-arm	241	218
replacement	127	160	Blocking-arm bracket		
Gears backlash adjustment	270	229	(TT-4B/TG)	242	219
Governor	7	6	Pressure-roller		
Governor contacts alignment	271	230	(TT-4B/TG)	232	214
And motor gear set, removal and			Pressure rollers		
replacement	60	77	(TT-4A/TG)	233	215
Series-governed type	6	5	Shaft end-play	229	214
Motor-stop:			Trough end-play	230	214
Coil adjustment	266	228	Trough-spring (TT-4B/TG)	228	213
Contacts and eccentric sleeves	264	227	Assembly, removal and		
Contact-lever adjustment	268	229	replacement	62	80
Contact-lever lug adjustment	263	227	Frame assembly, disassembly		
Contact-lever spring adjustment	265	227	and reassembly	76	95
Disassembly and reassembly	123, 125	157, 158	Trough assembly, disassembly		
Eccentric sleeves final adjustment	269	229	and reassembly	77, 78	97, 100
Relay switches preliminary			Platen-shift:		
adjustment	267	228	Final adjustment	240	218
Removal and replacement	122, 124	157	Preliminary adjustment	236	216
Mounting base:			Power distribution, mechanical	8	7
Disassembly and reassembly	132	167	Preliminary sending and receiving		
Removal and replacement	59	77	tests	286	238
Operation:			Preparation:		
Carriage-feed	23	25	Lubrication	48	60
Carriage-return	24	28	Tests	285	237
Figures-shift	26	33	Preventive maintenance:		
Inking ribbon:			Form, use	42	55
Feeding	29	40	Procedure, general	45	55
Lifter	30	41	Printing-bail:		
Reversing	29	40	And ribbon-lifter adjustments	227	212
Keyboard-transmitter, general	9	8	Blade adjustment	226	212
Keyboard-transmitter, sequence	15	14	Shaft, assembly, disassembly		
Letters-shift	27	36	and reassembly of	92	118
Line feed	28	37	Printing operation	22	22
Margin signal bell	25	33	Procedure, general preventive		
Motor-stop	32	44	maintenance	45	55
Page printer, general	16	14	Purpose of final testing	281	237
Printing	22	22	Random-end and parallel-end spring		
Selector-magnet	17	15	data	278	233
Selector mechanism	19	16	Rangefinder:		
Sensing-lever locking-bail	14	12	Cam-follower adjustment	177	189
Signal bell	31	42	Disassembly and reassembly	88	112
Space repeat	13	12	Mechanism	19	16
Transfer	20	19	Removal and replacement	87	111
Operations of teletypewriter	22	22	Shaft adjustment	176	189
Orientation lever adjustment	177	189	Receiving and sending tests,		
Paper-guide alignment adjustment	231	214	preliminary	286	238
Paper shaft, paper-shaft bracket, and			Receiving tests, final	287	239
paper chute:			Recommended lubricants	46	59
Disassembly and reassembly	126	160	Recording code impulses	19	16

	Paragraph	Page		Paragraph	Page
Records, maintenance forms _____	42	55	Selector-magnet—Continued		
Removal and replacement:			Armature adjustment _____	180, 181	190, 191
Carriage _____	63	80	Armature and selector-lever		
Carriage-feed shaft assembly _____	116	148	clearance adjustment _____	186	193
Carriage-return operating			Assembly, disassembly and		
mechanism _____	111	144	reassembly _____	86	108
Dust cover _____	57	77	Sensing-levers, adjustment:		
Function-shaft assembly _____	98	126	And selector-levers _____	142	175
Instrument panel _____	65	81	End-play clearance and alinement	141	175
Keyboard-transmitter _____	61	79	Locking-bail _____	144	176
Line terminal board _____	64	81	Sequence chart of adjustments for		
Main shaft assembly			TT-4A/TG and TT-4B/TG _____	135	171
(TT-4B/TG) _____	102	132	Series-governed type motor _____	6	5
Motor gear set and motor _____	60	77	Shaft operation, function _____	20	19
Motor-stop assembly:			Shop equipment and tools _____	39	54
TT-4A/TG _____	122	157	Side-plate and function punch-bar		
TT-4B/TG _____	124	157	adjustment _____	187	194
Motor filter box assembly _____	127	160	Signal-bell:		
Mounting base _____	59	77	Adjustment, final _____	262	227
Paper shaft, paper-shaft bracket,			Adjustment, preliminary _____	261	226
and paper chute _____	58	77	Disassembly and reassembly _____	93	119
Platen assembly _____	62	80	Operation _____	31	42
Rangefinder _____	87	111	Signaling code _____	4	5
Type-selecting arm _____	79	101	Space repeat operation _____	13	12
Repeat-blocking-lever adjustment			Spacing-collar and cam-followers		
(TT-4B/TG) _____	140	174	adjustment _____	156	181
Repeat operation, space _____	13	12	Special spring data _____	280	235
Return operation, carriage _____	24	28	Spring mechanism, armature _____	19	16
Reverse cam-follower adjustment,			Spring data:		
ribbon _____	259	226	Compression _____	277	232
Ribbon:			Crossed-end _____	279	234
Adjustment:			Parallel-end and random-end _____	278	233
Feed-clutch spring _____	253	223	Random-end and parallel-end _____	278	233
Feed mounting _____	251	223	Special _____	280	235
Reverse beam _____	254	223	Square-shaft:		
Reverse detent-plate _____	255	224	Disassembly and reassembly _____	97	126
Sensing-lever _____	258	225	Driven-gear adjustment _____	222	209
Spool shaft _____	252	223	Stop-arm torque adjustment _____	225	211
Spool driving-collar _____	256	224	Starting and stopping transmitter		
Spool friction-spring _____	257	225	camshaft _____	12	10
Disassembly and reassembly:			Stop:		
Feed mechanism _____	83	103	Motor, operation _____	32	44
Lifter assembly _____	81, 82	101, 103	Lever adjustment _____	182	191
Right-margin stopscrew adjustment			Start selector-lever-latch		
(TT-4A/TG) _____	213	206	adjustment _____	147	177
Sectionalizing trouble _____	52	71	T-levers:		
Selector camshaft assembly,			Alinement adjustment _____	161	183
disassembly and reassembly _____	100	180	Pivot stud adjustment _____	166	184
Selector friction-clutch adjustment _____	174, 175	188	Teletypewriter frame assembly,		
Selector-lever:			disassembly and reassembly _____	130	164
Adjustment _____	178	189	Teletypewriter TT-4(*)/TG, block		
And selector-magnet armature			diagram _____	5	5
clearance adjustment _____	186	193	Test:		
Comb adjustment _____	179	189	Equipment _____	41	54
Selector-levers and sensing-levers			Equipment required for final		
adjustment _____	142	175	testing _____	282	237
Selector-levers and Y-levers,			Insulation resistance _____	283	237
disassembly and reassembly _____	89, 90	113	Tests:		
Selector-magnet:			Final receiving _____	286	238
Adjustments _____	185	193	Final sending _____	287	239

	Paragraph	Page		Paragraph	Page
Tests—Continued			Troubleshooting:		
Preliminary sending and receiving	285	237	Charts	55	71
Preparation	284	237	General	51	71
Throw-out lever adjustment			TT-4(*)/TG:		
(TT-4B/TG)	215	206	Block diagram	5	5
Tools and shop equipment	39	54	Circuit description	34	47
Transfer-lever:			Differences in models	2	2
Roller-stud adjustment	163	183	Operations	22	22
Shaft assembly, disassembly and reassembly	91	116	Type-selecting-arm and function-selecting-arm adjustments	224	210
Shaft end-play adjustment	162	183	Type-bar group, disassembly and reassembly	84	106
Spring tension adjustment (TT-4B/TG)	164	184	Type-selecting arm:		
Transfer operation	20	19	Disassembly and reassembly	80	101
Transmitter:			Removal and replacement	79	101
Camshaft:			Universal-bar adjustment	139	174
And filter, disassembly and reassembly	72	87	Upper-stopscrew armature adjustment	183	192
End-play adjustment	137	173	Use of preventive maintenance form	42	55
Starting and stopping	12	10	v-lever:		
Contact adjustment	147	177	Adjustment:		
Contacts, assembly, disassembly and reassembly	68	83	Detent and v-lever (TT-4B/TG)	172	187
Friction-clutch adjustment	145, 146	176	Eccentric stop, preliminary	165	184
Stationary contact adjustment	148	177	Friction (TT-4A/TG)	173	187
Transmitting mechanism	9	8	Stud-bracket (TT-4B/TG)	167	185
Troubles:			And selector levers, disassembly and reassembly	89, 90	113
Electrical, localizing	53	71			
Mechanical, localizing	54	73			
Sectionalizing	52	71			