

TUW200 HIGH SPEED TAPE UNWINDER

CONTENTS	PAGE
1. GENERAL	1
2. DESCRIPTION	1
3. PRINCIPLES OF OPERATION	1
4. INSTALLATION	1
5. ADJUSTMENTS	3
Drive belt tension	6
Pinch roller spring	5
Slack tape switch	4
Switch position	4
Tape depressor	5
Tight tape switch	4
6. LUBRICATION	6
Tape roller	6
7. DISASSEMBLY AND REASSEMBLY	6

1. GENERAL

1.01 This section provides the description, principles of operation, installation and maintenance procedures for the TUW200 high speed tape (outside) unwinder.

1.02 The high speed tape unwinder supplies paper tape for a reader or punch unit from a large tape supply roll at speeds up to 2400 wpm.

2. DESCRIPTION

2.01 The high speed tape unwinder is a self-contained motor driven device for pulling tape from its storage bin as the associated unit processes the tape supply. The tape is pulled from the bin by the motor driven pinch roller which is actuated by a mercury switch and a tape sensing arm. The mercury switch is attached to the tape sensing arm and functions within rather narrow limits at the midpoint of its range of travel.

2.02 The tape bin will accommodate up to 3000 feet of 11/16 inch to one inch tape either plain, or fully perforated (1500 feet of chadless

tape). Note that the tape is to be wound with the beginning of the (perforated) text at the outside of the roll.

2.03 A conventional tape reel is not used since the roll is not supported at its center. Rather, the narrow tape bin holds the roll in tact as the self-contained tape puller (motor driven) unwinds the tape from the outside of the roll. In applications where a large-core tape reel is used in winding the tape, the unwinding operation will require a business machine ring (similar to TP147707) to support the center portion of the roll.

3. PRINCIPLES OF OPERATION

3.01 In operation, a roll of tape (without a reel or spindle) is oriented so that the leading edge of the outside loop of the roll is directed from the bottom of the roll toward the tape puller. The roll is placed into the tape bin through the elongated opening at the top of the unwinder. The leading edge of the outside loop is then threaded through the tape sensing arm, the tape guide loop, and routed to the associated punch or reader unit.

3.02 A flexible strap supports the tape roll in the unwinder tape bin. The rear end of the strap may be lifted upward to facilitate the removal or addition of tape. Exercise care as the tape roll is inserted into the bin to make sure that the inside end of the tape roll does not protrude at its center.

4. INSTALLATION

4.01 The tape unwinder may be placed on an adjacent table with its tape output directed toward the high speed sender cabinet. Also a shelf (modification kit TP148164) may be obtained for locating the unwinder on the side of the main cabinet.

4.02 Three cabinets are available for mounting the tape handling equipment at a level with the tape processing units in the high speed sender or receiver cabinet. The accessory cabinets are placed adjacent to the main cabinet; the con-

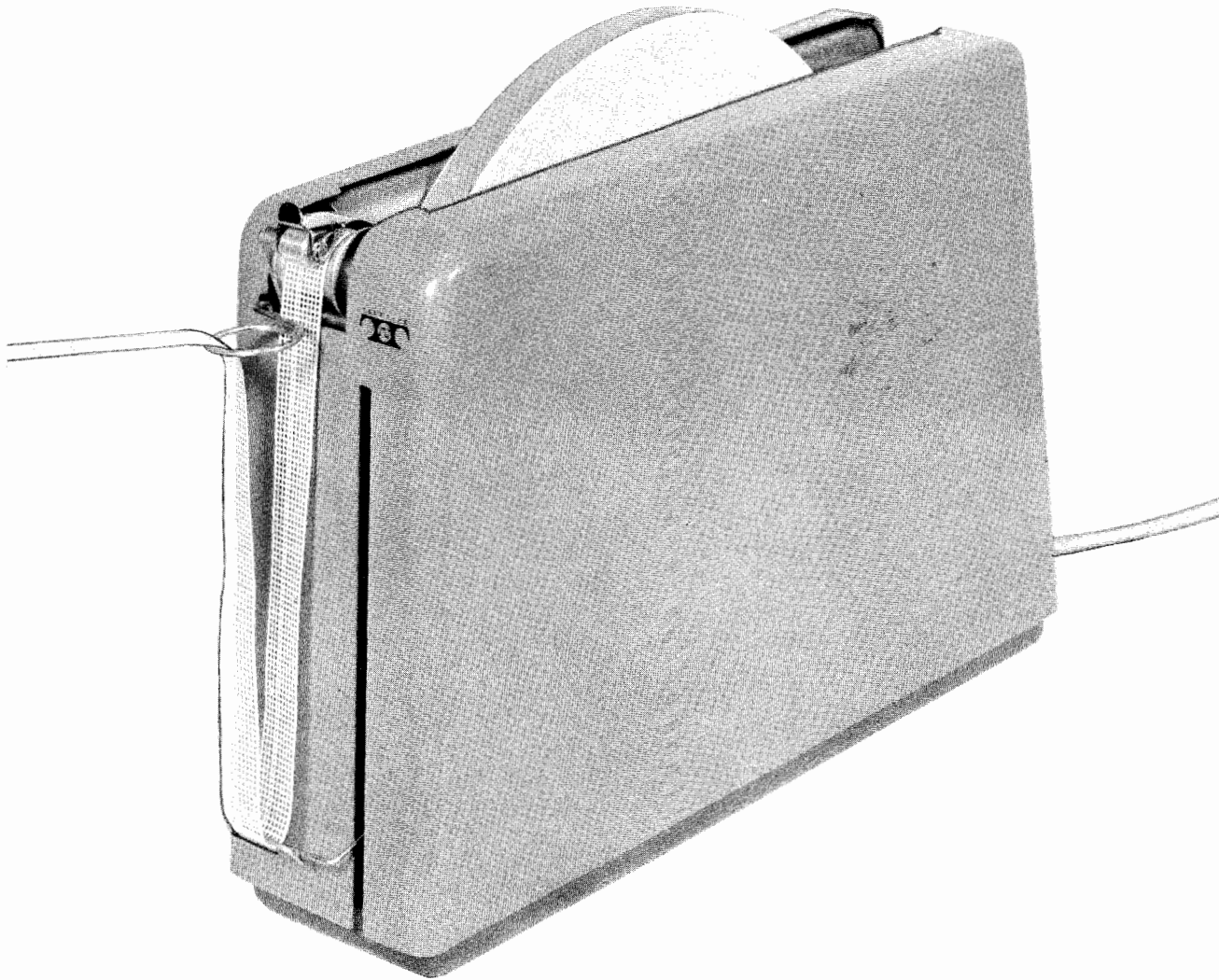

Figure 1 - High Speed Tape Unwinder

tour conforms with the high speed tape-to-tape system. A tape unwinder, a tape winder, or a combination of the tape handling devices are housed in the respective cabinet which is placed at the right or left side of the main cabinet to meet the requirements of the tape flow.

4.03 Operating Instructions

(a) Connect the power cord to a 115 volt ac outlet.

(b) Insert the tape roll into the tape bin with the outside of the tape (coming off the bottom of the roll) directed toward the tape puller.

(c) Keep the tape on the inside diameter of the roll flat as the tape is inserted in the tape bin.

(d) To remove any telescoping effect, drop the tape lightly on the flat surface of a table.

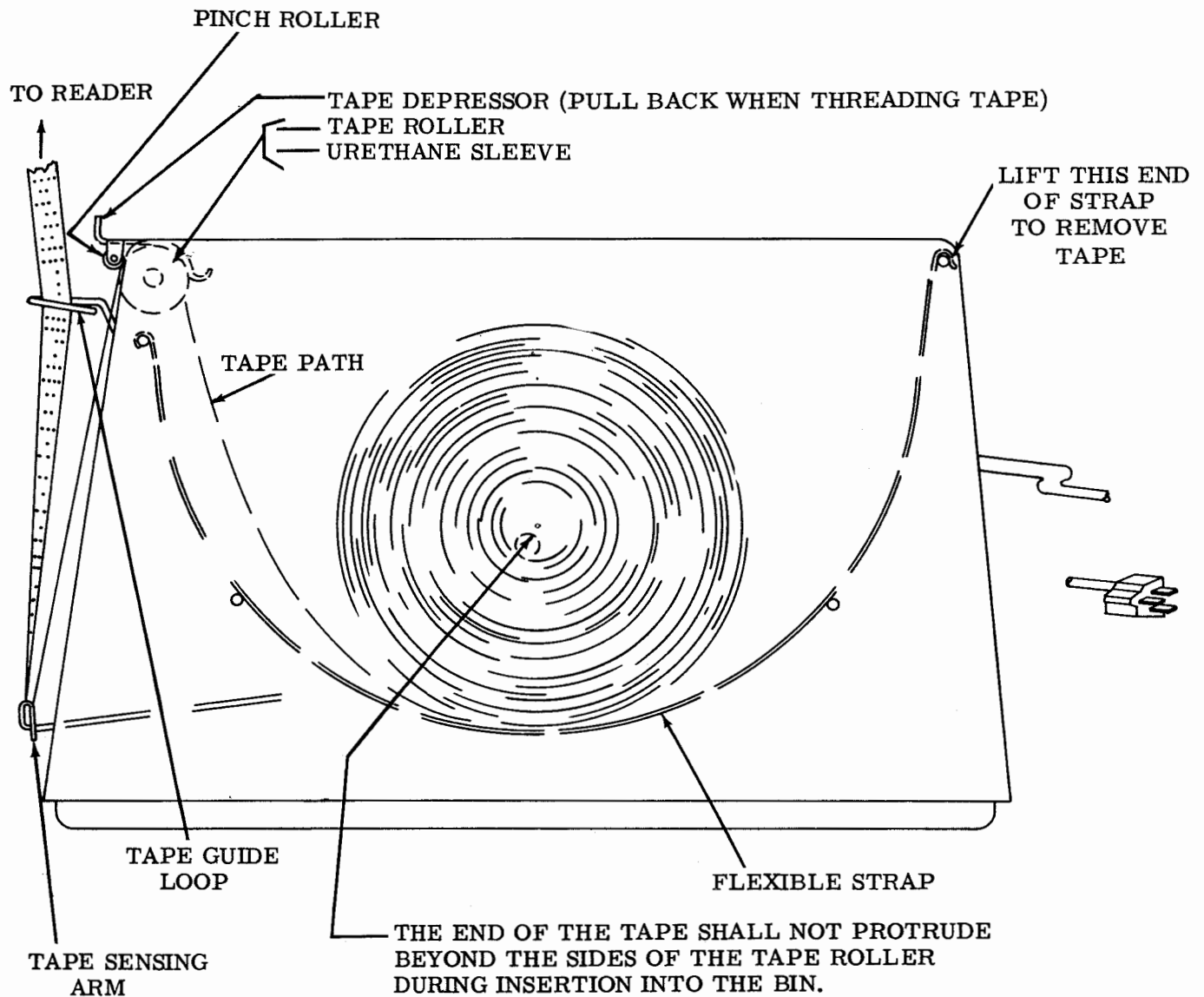

Figure 2 - Tape Path of Tape Unwinder

- (e) Unroll several feet of tape and thread it under the tape depressor through the tape sensing arm, over the tape guide loop and into the tape reader.
- (f) The unwinder will turn on when the tape sensing arm is raised.
- (g) The tape sensing arm drops automatically to turn off the unwinder when the end of the roll of tape is reached.
- (h) Lift the rear end of the tape bin strap upward to remove the tape roll.

5. ADJUSTMENTS

- 5.01 The following line drawings show adjusting tolerances, position of parts, and spring tensions. Refer to Figure 3 for the location of the assemblies.
- 5.02 Reference to the left, right, up, down, front and rear refer to the apparatus in its normal operating position in the set, as viewed from the operator's position in front of the associated cabinet.

5.02 Slack Tape Sensing Assembly

SLACK TAPE SWITCH

To Check

With tape in motion, the OFF-ON excursion of the tape arm shall occur in approximate midrange of tape arm travel.

Requirement

Tape sensing arm motor ON position shall occur when arm is raised to height of
Min 4-3/4 inches---Max 5-1/4 inches

To Adjust

Note: Tight tape switch must be in its closed circuit condition (tilted counter-clockwise to engage mercury with contacts).

With tape sensing arm downward, slack tape switch clamp screw friction tight, and slack tape switch in open circuit condition, position switch so as to close motor power circuit at nominal height of 5 inches.

Note: Remove power from unit before initiating adjustment.

TIGHT TAPE SWITCH

Requirement

Motor shall turn OFF as tape sensing arm is fully raised to height of
Min 9-3/4 inches---Max 10-1/4 inches

To Adjust

With tape sensing arm raised 10 inches (motor circuit closed) and tight tape switch clamp screw friction tight, tilt switch (clockwise) to open circuit power input line.

OPERATION TO OCCUR IN MIDRANGE OF TOTAL TAPE SENSING ARM MOVEMENT

MOTOR TURNS ON

TAPE SENSING ARM

SLACK TAPE MERCURY SWITCH

TIGHT TAPE MERCURY SWITCH

CABLE CLAMP MOUNTING SCREWS

SWITCH POSITION

Requirement

Each switch should be oriented so that its internal (mercury wetted) terminals lie in same plane.

To Adjust

With respective clamp screw loosened, tilt one or both switches to align the (4) terminals.

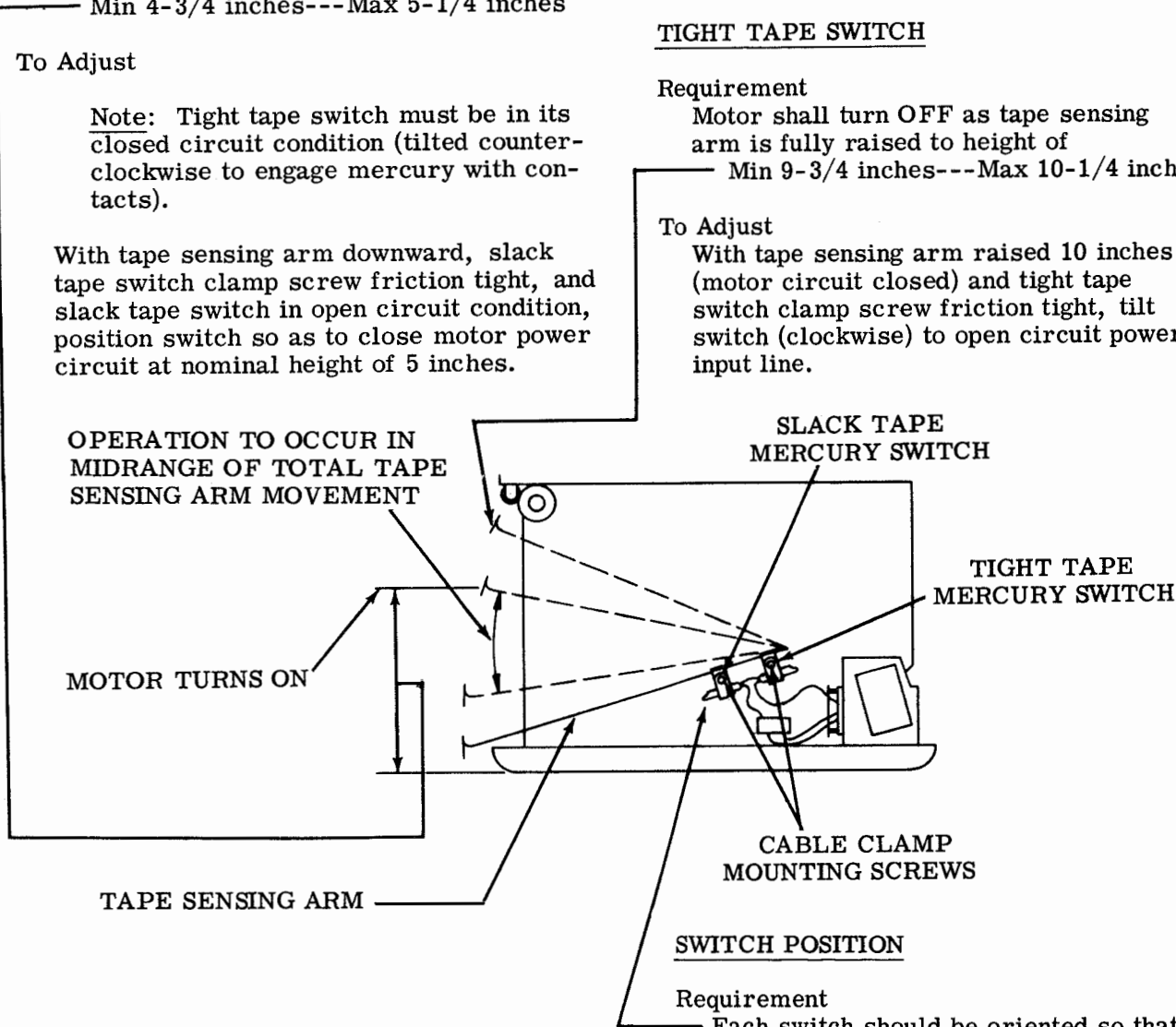

5.03 Tape Puller Assembly

TAPE DEPRESSOR

Requirement

With tape threaded over drive roller, clearance between tape and tape depressor at closest point

Min _____ Some---Max 0.060 inch

To Adjust

With pinch roller shaft locknut friction tight, position the shaft.

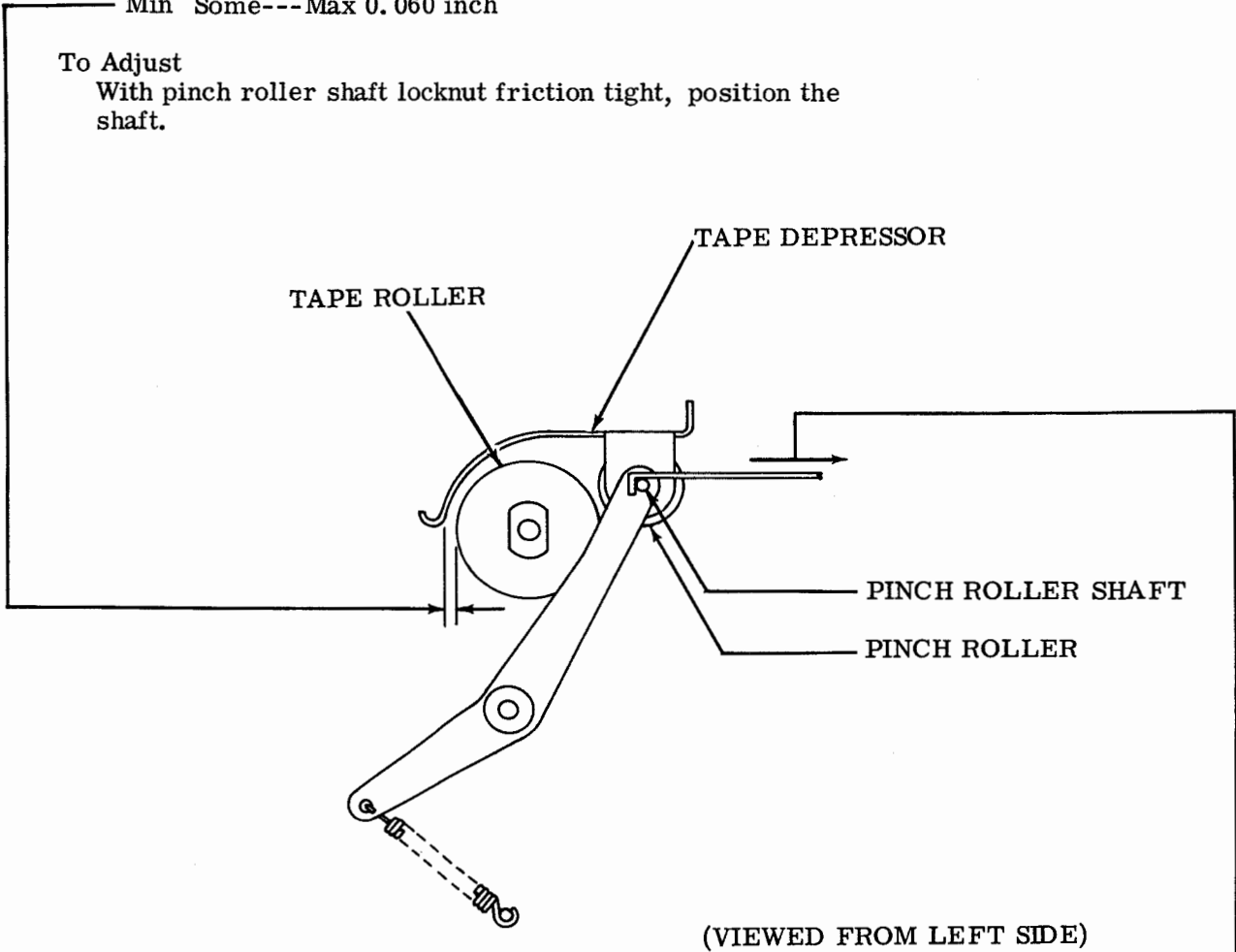

PINCH ROLLER SPRING

Requirement

With spring scale hooked on pinch roller shaft

Min 8 oz---Max 15 oz _____

to start shaft moving.

5.04 Tape Puller Drive Assembly

DRIVE BELT TENSION

Requirement

With push end of spring scale applied to center of drive and using a pressure of 5 oz the belt should deflect
Min 7/16 inch---Max 9/16 inch

To Adjust

With motor mounting screws friction tight, position the motor.

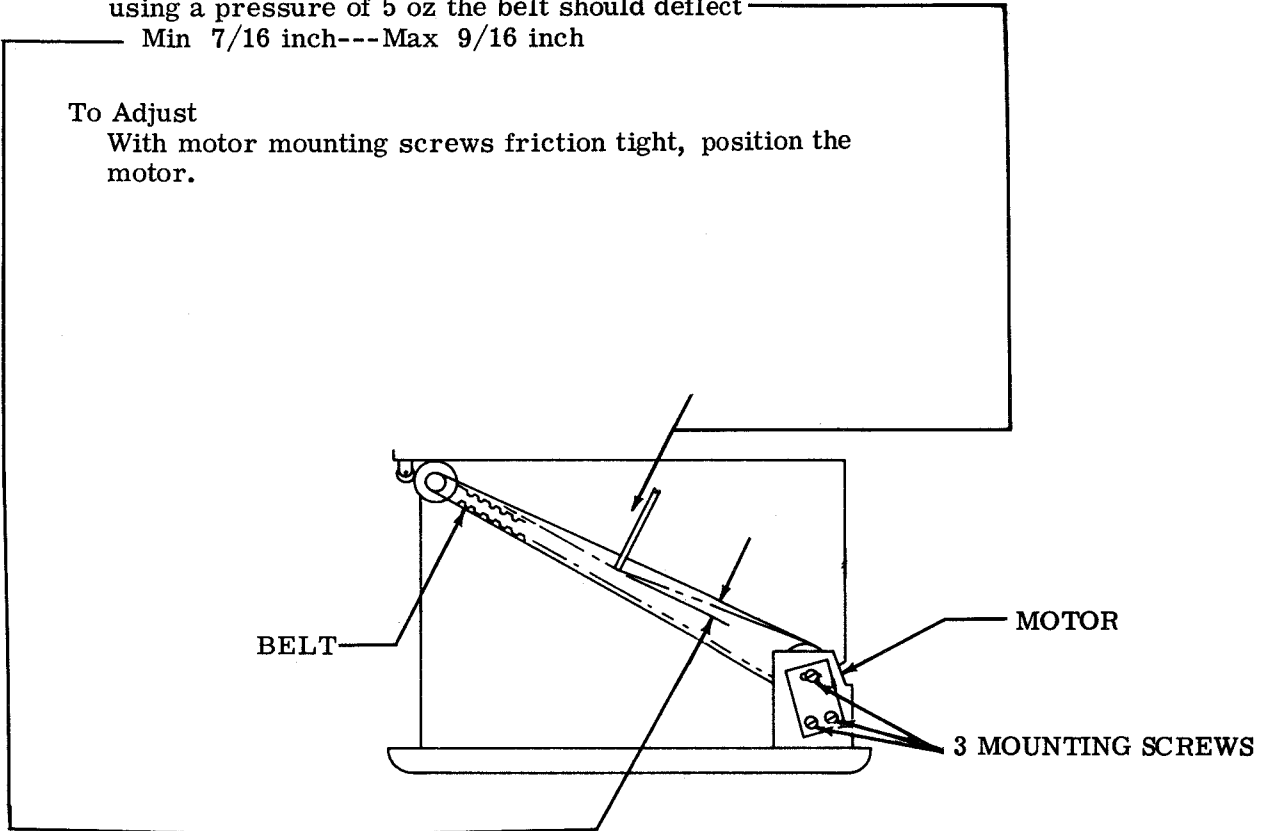

6. LUBRICATION

6.01 The following markings are lubrication symbols used on the illustration to indicate the type and amount of lubricant required.

<u>Symbol</u>	<u>Meaning</u>
O3	Apply 3 drops of oil.

6.02 Use KS7470 oil sparingly as shown. Lubricate every 500 hours or every six months, whichever occurs first.

7. DISASSEMBLY AND REASSEMBLY

7.01 Motor not to be repaired. Disassembly of tape puller is self-explanatory.

6.03 Tape Roller

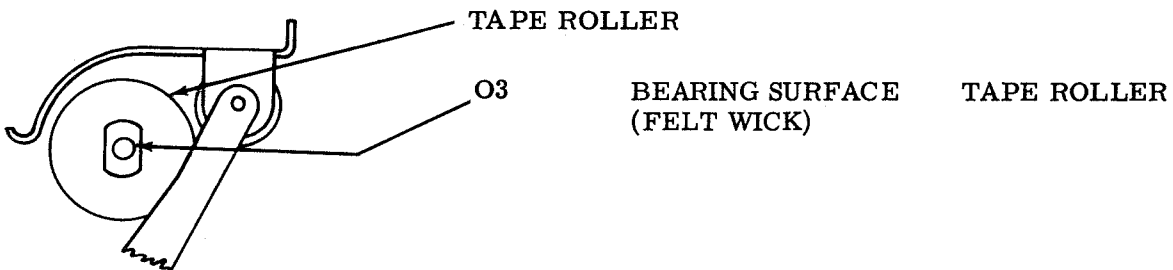

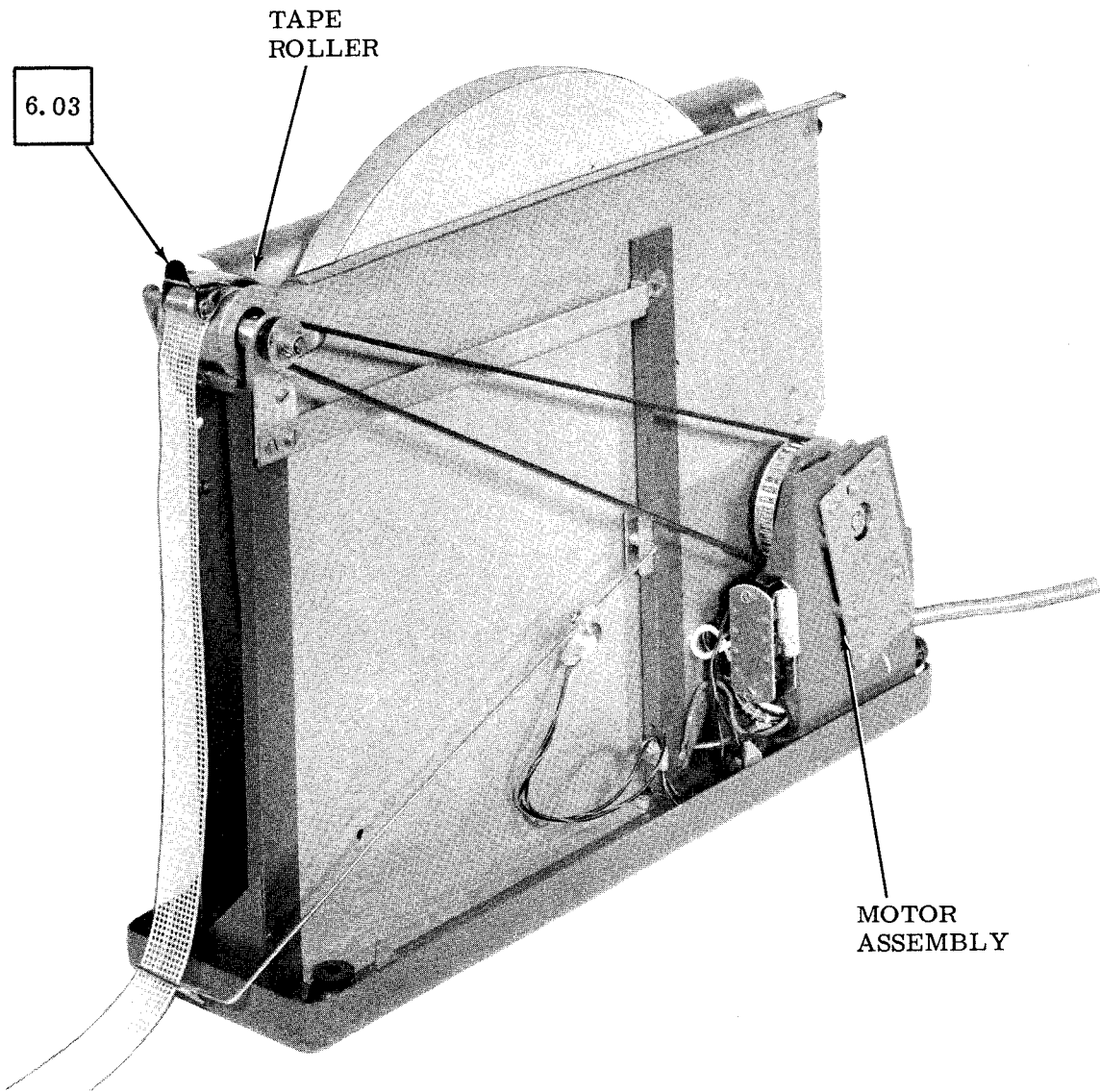

Figure 3. Tape Unwinder with Cover Removed

