

DATASPEED TAPE-TO-TAPE SYSTEM

TYPE 1 AND TYPE 2 TAPE SENDERS AND RECEIVERS

GENERAL DESCRIPTION AND OPERATING PROCEDURE

CONTENTS	PAGE
1. INTRODUCTION.	1
2. GENERAL.	1
3. DESCRIPTION.	2
4. PRINCIPLES OF OPERATION	4
5. CONTROLS.	4
6. OPERATING PROCEDURES - MANUAL	6
TAPE SENDER	6
TAPE RECEIVER.	8
7. OPTIONAL FEATURES.	13
TAPE SENDER	13
A. Signal Converter with Rubout Delete	13
B. Line Break and Automatic Answer.	13
C. Interim Unattended Answer (Private Line)	15 ←
D. Automatic Disconnect	15 ←
TAPE RECEIVER	15
A. Automatic Answer	15
B. Resynchronizer Modification	16
C. Automatic Answer and Disconnect	16 ←
TAPE SENDER AND RECEIVER.	16
A. Transmit-Receive Terminal Kit (Early Design)	16 ←
B. Send-Receive Terminal Kit (Later Design)	16
C. Optional Auxiliary Equipment.	17
SYSTEM FEATURES	17
A. Break Feature.	17
B. Discrete Calling.	18 ←

1. INTRODUCTION

1.01 This section is primarily concerned with the 1A and 2A Tape Senders and 1B and 2B Tape Receivers used in the DATASPEED Tape-to-Tape System. The section presents general descriptive and operating information for the Senders and Receivers. Part 7 deals with various optional features.

1.02 This section is reissued to incorporate information on the discrete calling feature, the break feature, the automatic answer and disconnect feature, and the new Y-connector kit. It also adds information on the new application of existing kits. Arrows in the margins indicate changes and additions.

2. GENERAL

2.01 The Tape Senders and Tape Receivers serve as the system input and output terminals. Data, perforated in paper tape, is translated into electrical impulses by the Tape Sender. These impulses serve as the modulating signal for an associated data set. The modulated tone output of the data set is then applied to a two-wire telephone grade channel. At the Tape Receiver site, a data set demodulates the tone signal, translating it to electrical impulses. These impulses are used to activate a tape punch (reperforator) at the Tape Receiver. In this fashion, data may be transmitted from tape-to-tape at a 1050 word per minute rate.

2.02 There are two types of Sender and Receiver equipment: type 1 and type 2. Type 1 equipment is designed for 5-level operation only. Type 2 equipment has adjustable features and will accommodate 5, 6, 7, or 8-level tapes. The principle of operation is the same for both types. Additional levels are provided in type 2 equipment by adjustable reader heads and tape punches, and use of additional mechanical and electrical components. Operation of a switch at type 2 stations

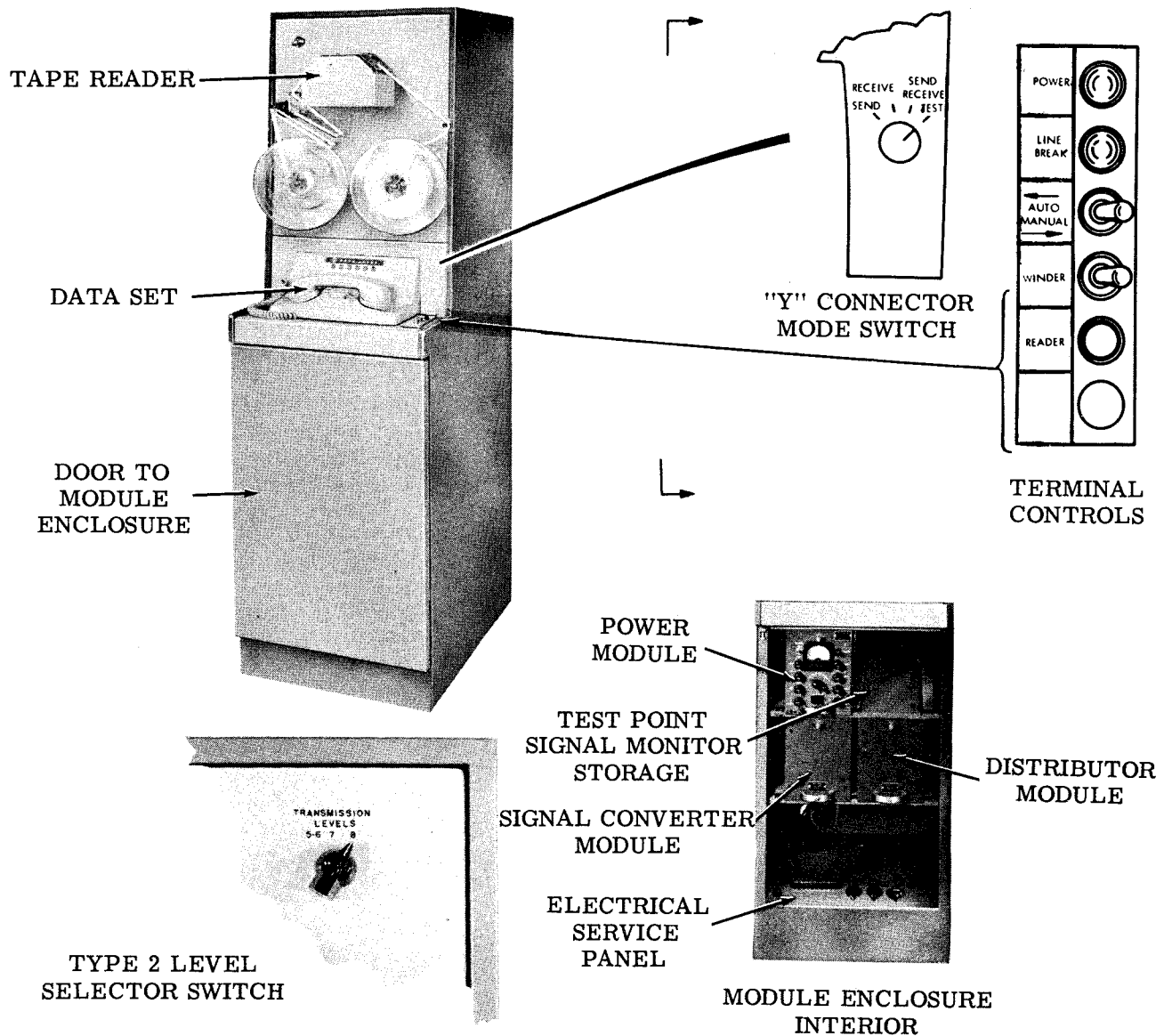

Figure 1 - Tape Sender Terminal

allows 5-level transmission between type 1 and type 2 equipments.

3. DESCRIPTION

3.01 General: The equipment necessary for tape-to-tape operation consists of two units: A tape sender terminal (Figure 1) and a tape receiver terminal (Figure 2). A Bell System 202A, 202C, or 202D, Data Set is required at each installation using the telephone network. A Bell System 202B Data Set is required for private line installation. The basic components of each terminal are shown in Table 1.

TABLE 1 - BASIC COMPONENTS

Tape Sender	Tape Receiver
Tape Reader	Tape Punch
Sending Distributor	Receiving Distributor
Signal Converter	Signal Converter
Power Supply	Power Supply
Tape Reels	Tape Reels
Controls	Controls
Sender Cabinet	Receiver Cabinet

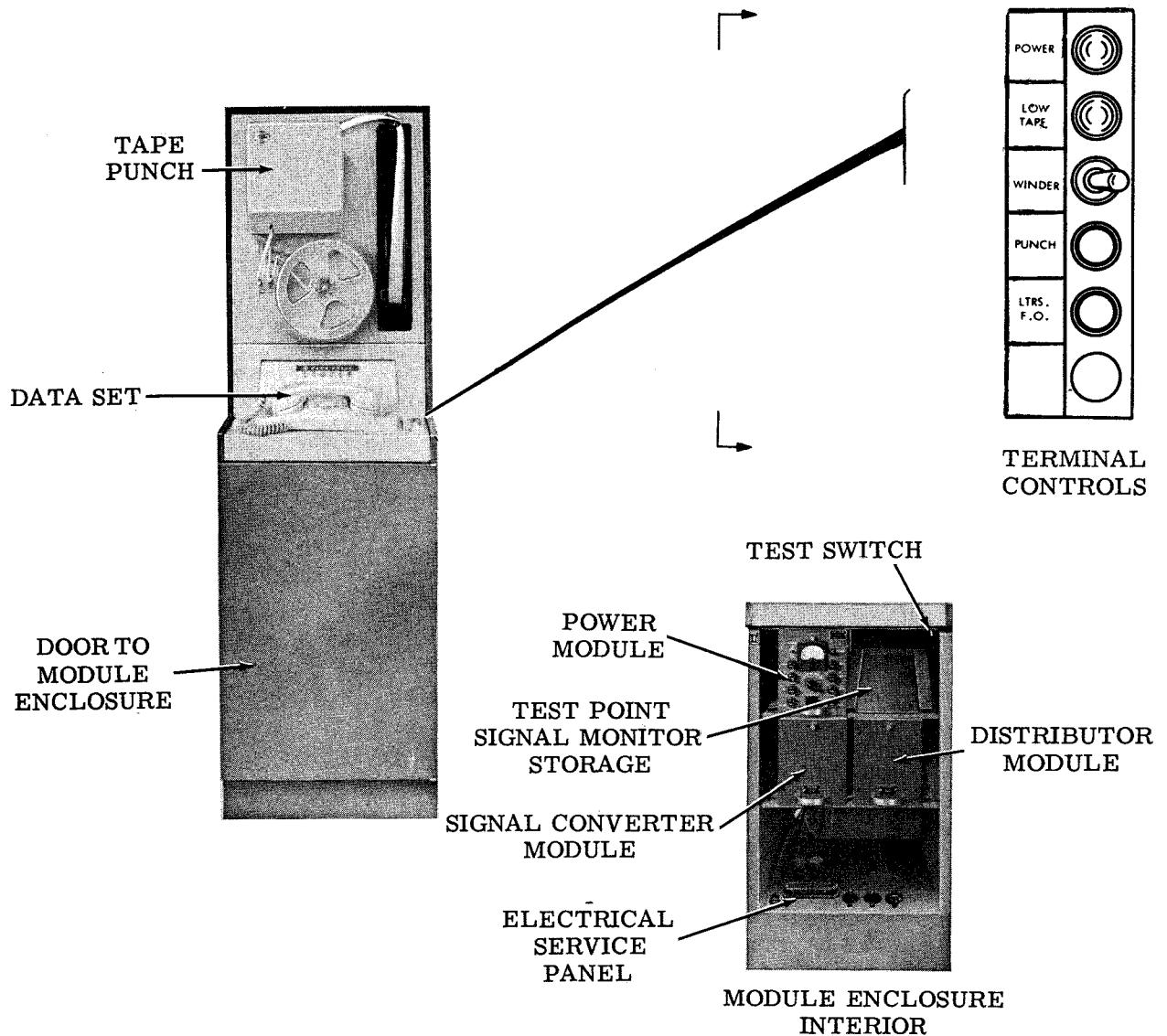

Figure 2 - Tape Receiver Terminal

3.02 Cabinets: The tape sender terminal and tape receiver terminal cabinets are very similar in appearance, and identical in physical size. Although normally furnished in a two-tone gray color combination, two-tone beige or green color combinations are also available.

(a) Each cabinet is of sheet metal, steel reinforced construction. They are floor standing units, housing all the mechanical, electrical and electronic components necessary for operation. The basic cabinet shell

is 16 inches wide, 54-1/4 inches high, and 24-3/8 inches deep. The Tape Sender weighs 160 lbs without the data set. The Receiver weighs 176 lbs, again, without the data set. Operating controls are located on the shelf directly above the lower enclosure. Immediately left of the controls is the mounting area for a data set.

(b) A front sliding panel, located in the upper enclosure of the cabinet, provides mounting facilities for tape handling and mechanical signal generating or receiving equipment. The panel is supported by steel

braces, and slides forward on nylon bearings to allow access to the equipment mounted behind the panel.

(c) The lower enclosure provides mounting facilities for three electronic modules, and a storage area for a test point signal monitor. The modules slide onto individual mounting trays supported by steel cross members. A lock is provided on each module to secure it in its mounting location. Each module slides forward on its mounting tray for inspection, minor repair, or testing purposes. A safety latch at the right rear corner of the module prevents it from being accidentally pulled off its tray. For access to the lower enclosure, the front door is provided with a self-releasing latch. Pushing in on the upper left corner of the door releases the latch and allows the door to open. The door is latched by simply closing the door until the latch engages.

3.03 Mechanical components: The high speed tape reader and tape punch mount on the sliding front panel of their respective cabinet along with their associated tape handling equipment. For a description of the tape reader and tape punch mechanisms, refer to the appropriate Bell System Practice, or to manuals 267B and 215B respectively.

(a) The tape handling facilities associated with the Tape Sender and Tape Receiver units operate in basically the same manner. The major difference between the systems is that the tape supplied to the tape reader is a perforated "message tape," while the tape supplied to the tape punch is blank. In either case, tape is directed to the mechanical unit from a supply reel located on the right side of the upper enclosure front sliding panel. Movement of the supply reel is controlled by the tape feed mechanism of the mechanical unit, and by a friction type brake arm which rides the tape. In the tape receiver terminal, a low tape alarm is actuated by the brake arm when the tape supply is nearing depletion.

(b) The perforated tape leaves the left side of the mechanical units, and is routed to the respective tape winder (take-up) reel. Initially, the message tape is manually routed through the winder mechanism. After this manual operation, the tape is automatically wound on the take-up reel as it

emerges from the tape reader or punch. An electric motor, mounted behind the sliding front panel, drives the take-up reel. Operation of the motor is controlled via a mercury switch operated by the tape sensing arm. The position of the tape sensing arm determines whether the mercury switch contacts are open or closed; therefore, whether the motor is off or on.

4. PRINCIPLES OF OPERATION

4.01 The signal transmission path for operation of the system is established via the data sets associated with the Tape Sender and Tape Receiver. A simplified block diagram of the system appears in Figure 3.

4.02 The send function begins when a pre-punched message tape is placed in the tape reader, and the proper controls are operated. As tape feeds through the reader, tape signals, plus start-stop signals, are fed to the signal converter in parallel arrangement. The signal converter reshapes the signals and passes them on to the sending distributor. The sending distributor converts the signals from their parallel form into serial form. From here they are passed, a bit at a time, back through the signal converter to the data set in the form of positive and negative dc voltage signals. The data set converts the dc signals into voice-frequency tones. These tones are transmitted over the previously established telephone circuit to the distant receive station.

4.03 At the receive station, signals received by the data set are converted from voice-frequency tones to dc serial signals and passed through the signal converter to the receiving distributor. Here they are converted into parallel signals and routed back through the signal converter to the tape punch which punches the received message in paper tape.

5. CONTROLS

5.01 The controls used in operating the Tape Sender and the Tape Receiver are located on the horizontal shelf immediately to the right of the data set (see Figures 1 and 2). A brief description of these controls is given in Table 2.

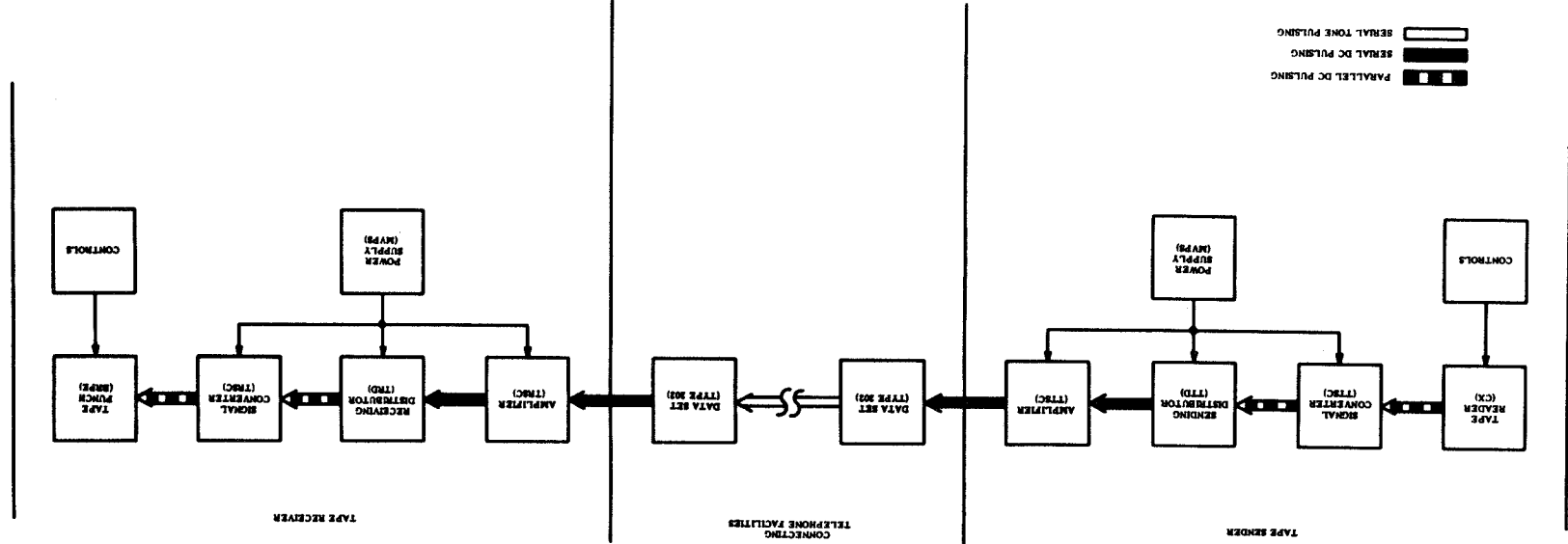

Figure 3. System Block Diagram

TABLE 2 - CONTROLS

Equipment	Designation	Type of Control	Function
Tape Sender Terminal	POWER	Lamp (orange)	Indicates ac power switch on
	LINE BREAK	Lamp (red)	Indicates line break
	AUTO MANUAL	Toggle switch	Determine automatic or manual controls
	WINDER	Pushbutton* or Toggle switch**	Starts or stops winder motor
	READER	Pushbutton*	Starts or stops reader motor
Tape Receiver Terminal	POWER	Lamp (orange)	Indicates ac power switch on
	LOW TAPE	Lamp (red)	Indicates tape near end of reel
	WINDER	Pushbutton* or Toggle switch***	Starts or stops winder motor
	PUNCH	Pushbutton*	Starts or stops tape punch motor
	LTRS FO	Pushbutton #	Feeds out tape

* Nonlocking button. (Button restores automatically after being depressed; contacts remain operated until button is again depressed and released.)

→ ** Toggle switch on units with TP146775 Modification (on units manufactured after 1st quarter 1964).

→ *** Toggle switch on units with TP146774 Modification (on units manufactured after 1st quarter 1964).

Nonlocking button which must be held down during operation.

6. OPERATING PROCEDURES - MANUAL

(3) Thread the tape (see Figure 4):

TAPE SENDER

6.01 Procedures for operating the tape sender terminal are as follows:

(1) Turn the ac power supply on (switch is located on power module), and check that the POWER lamp (orange) located on the control panel lights. Since the equipment is designed so that the power may be left on permanently, this operation will seldom be required.

(2) On universal units (ie, type 2), select the appropriate transmitting code level by operating the level selector switch at the upper right corner of the cabinet (see Figure 1). Rotate the level selector on the tape reader (located at right front corner of reader) to match the level selector switch setting.

Note: The above step is not necessary on type 1 terminals.

(a) Place a roll of punched tape on the supply reel. Place the supply reel and the take-up reel on the right and left tape reel hubs, respectively. Chadless tape must be rewound before it is placed in the tape reader, since the reader cannot read chadless tape traveling in a reverse direction.

(b) Thread the tape through the supply reel brake arm, and manually unwind approximately 3 feet of tape.

(c) Place the tape reader control lever in the FREE position. Thread tape through the reader gate.

(d) Lift the chad depressor arm and move the tape-tension arm to the extreme left. Release the chad depressor to lock the tension arm in place.

(e) Pass the tape between the stationary U-shaped post and the posts on the tension arm, and then upward between the chad depressor and its post.

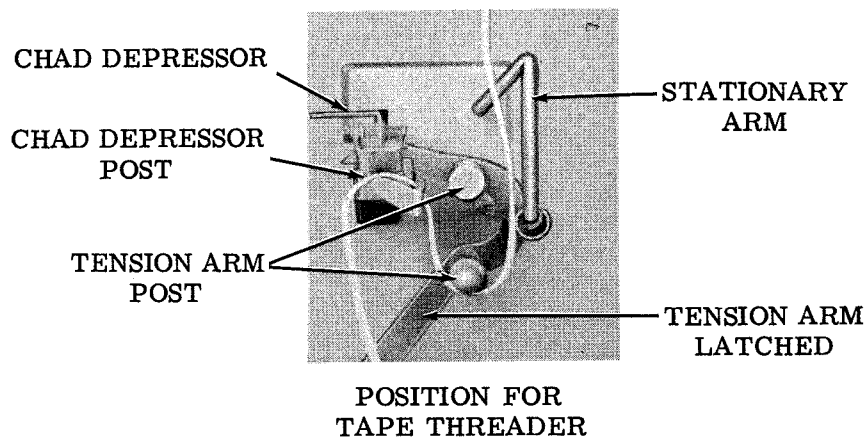
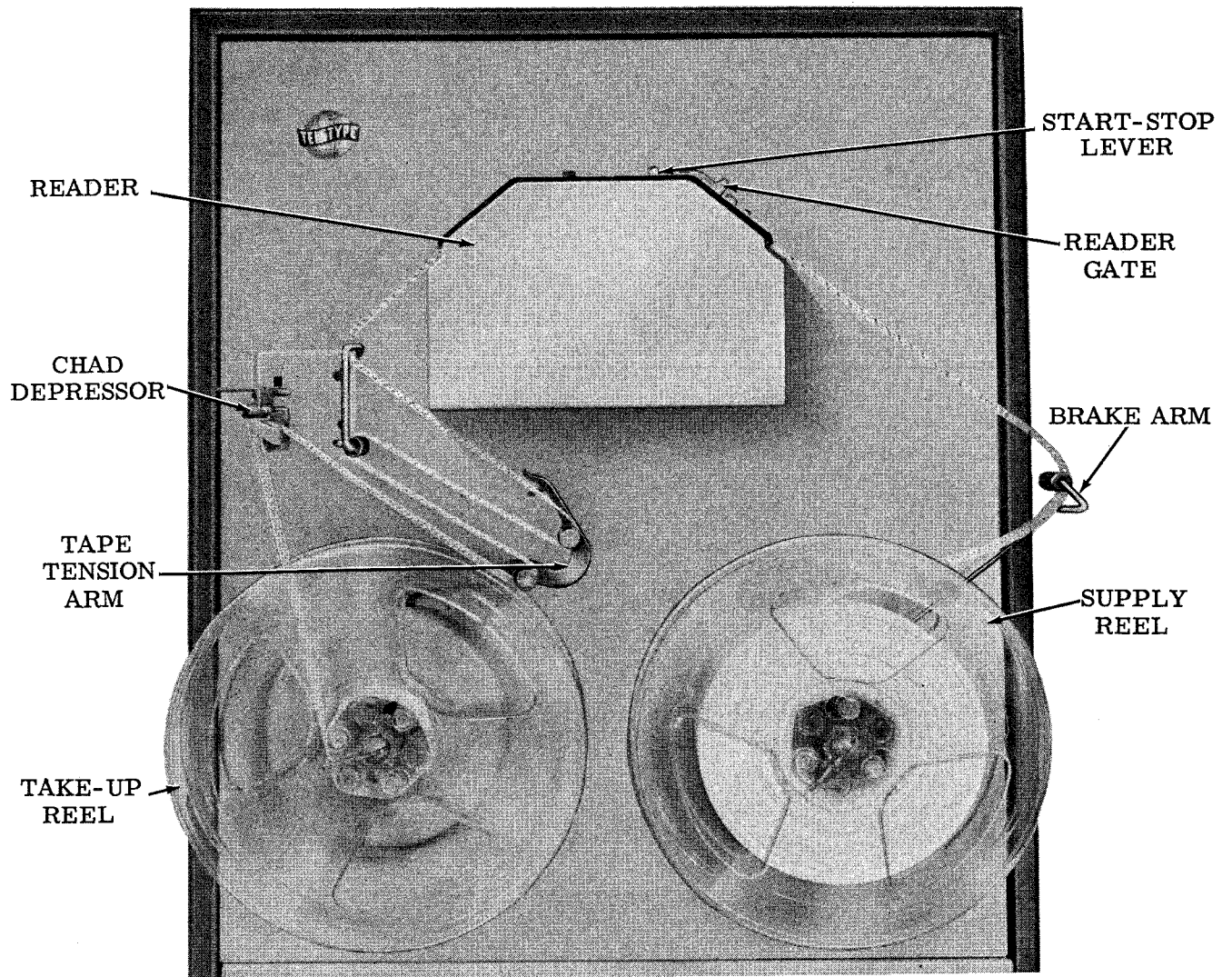

Figure 4 - Tape Path for Sender Terminal

(f) Hold tension on the free end of the tape, and lift the chad depressor arm while allowing the tension arm to rotate to the right.

(g) Place the end of the tape in the take-up reel. Manually rotate the reel counterclockwise two revolutions to secure the tape to the reel.

(h) Operate the WINDER switch to energize the winder motor. The winder shall automatically wind any excess tape and turn off, indicating proper operation of the winder mechanism. During normal operation, the winder motor is controlled by a mercury switch attached to the tape tension arm mechanism, and operates intermittently as the arm travels up and down.

(4) Check that AUTO-MANUAL switch is in the MANUAL position.

(5) Operate the TALK button on the data set, and establish a talking path to the receive station.

(6) Request the operator at the receive station to select the proper operating level (type 2 units only), and to operate the WINDER and PUNCH switches. Depress the READER button on the Sender. Tell the Receiver operator to depress the DATA button as soon as he hears the tone transmitted by the Sender.

(7) Depress the DATA button on the Sender data set. The DATA lamp shall light. Wait at least 5 seconds to allow the Receiver operator time to go to DATA mode. Move the reader control lever to the RUN position. Transmission will now begin and the handset can be placed on its cradle.

CAUTION: SINCE THE INCOMING LINE AT THE RECEIVE STATION IS OPEN UNTIL THE TRANSMITTER STARTS SENDING, NOISE TRANSMITTED ON THE LINE WILL CAUSE GARBLE TO BE PUNCHED IN THE TAPE. THE SENDER OPERATOR SHOULD COVER THE HANDSET TRANSMITTER TO PREVENT MOTOR SOUNDS, BREATHING, AND OTHER NOISES FROM PUNCHING GARBLE. A PUSH-TO-TALK

HANDSET MAY BE PROVIDED LOCALLY TO ELIMINATE THIS CONDITION.

(8) To terminate the call:

(a) Move the reader control lever to the STOP position.

(b) Operate the READER and WINDER switches to stop the motors.

(c) Depress the TALK button on the data set, lift the handset, and then hang up.

TAPE RECEIVER

6.02 Procedures for operating the tape receiver terminal are as follows:

(1) Turn the ac power supply on (switch is located on power module), and check that the POWER lamp (orange) located on the control panel lights. Since the equipment is designed so that the power may be left on permanently, this operation will seldom be required.

(2) Select the desired receiving code level by operating the proper combination of level selector switches, and selecting the proper tape path width (see Figure 5). The controls for making the proper selection of code level and tape path width are located on the tape punch. They are available when the punch cover is removed.

Note: This step is necessary only on universal (ie, type 2) terminals.

(a) To perforate 5 level - 11/16" tape, lift up on the control lever (located at the right side of the punch block) and allow it to move forward. Operate the switches for the 0, 6, and 7 levels to their OMIT positions. Move the tape guide plate to its forward detented position.

(b) To perforate 5, 6, 7, or 8 level - 1" tape, push the control lever to the rear, while applying a slight downward pressure, until the control lever reaches its rear detent position. Operate the switches for the 0, 6, or 7 code levels to

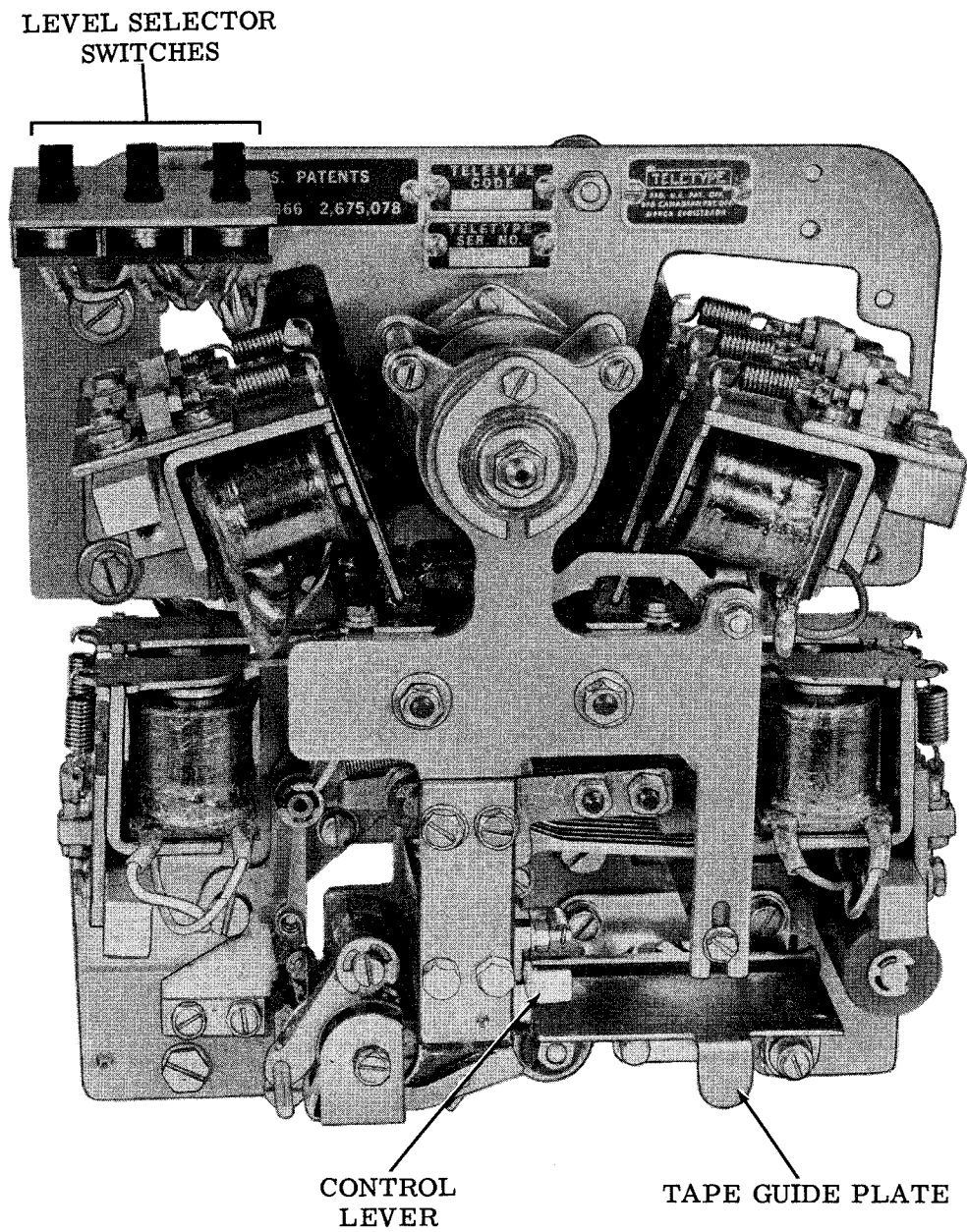

Figure 5 - Type 2 Tape Punch

their ON positions, depending upon the level of operation desired. Move the tape guide to its rear detented position.

(3) Thread Tape (See Figure 6):

(a) Arrange the tape supply reel retainers and latches to accept the tape width being used (see Figure 7). Load a roll of tape (3000 feet) on the supply reel, and place the reel on the bearing rail in the cabinet. The brake arm may be held out of the way by the upper roller while the supply reel is being put in place.

(b) Remove the tape punch cover. The cover is held in place by a magnetic lock at the top. It is removed by pulling it away from the cabinet and applying a slight downward pressure.

(c) Thread tape through brake arm and the rollers, and through the punch block. Approximately 2 inches of tape should extend beyond the punch block.

(d) Depress the PUNCH button, and then depress and hold the LTRS FO button while pulling rapidly on tape. This will start the tape through the tape punch. Release the LTRS FO button after approximately 3 feet of tape is fed out.

(e) Replace the tape punch cover.

(f) Lift the tape-tension arm until it raises the chad depressor.

(g) Route the tape between the posts on the tension arm and the U-shaped stationary post from left to right.

(h) Release the tension arm. While holding the free end of the tape taut, release the chad depressor and allow the tension arm to return to its original position.

(i) Place the free end of the tape in the take-up reel, and put the reel on its hub. Engage the driving dog on the winder hub, and turn reel counterclockwise to start the tape on the reel.

(j) Operate the WINDER switch to energize the winder motor. The winder shall automatically wind any excess tape. As the tape tension arm nears its upper limit, the motor will cut off. During normal operation, the winder motor is controlled by a mercury switch attached to the tape tension arm, and operates intermittently as the arm travels up and down.

(k) Depress the LTRS FO button momentarily, and check the tape path for proper feeding.

(4) To facilitate off line testing of the control electronics, a test switch (located in the receiving distributor module) is provided. This switch, when in the TEST position, provides a spacing signal on the distributor input, causing the tape punch to feed out blank tape. It serves as a quick check of components - excluding the data set. With the switch in the TEST position, a Data Test Set TTSG800 or 801 (905B or 905A) can be used to make local tests.

Note: In earlier Receiver units a test switch is located directly below the terminal controls. This switch is rendered useless with the addition of the test switch in the receiving distributor module, and has been eliminated on subsequent units.

(5) Depress the PUNCH button to stop the punch motor.

(6) Depress the TALK button on the data set, and establish a talking path to a send station in the normal telephone manner.

(7) Depress the PUNCH button. When the punch motor starts, advise the send station that the set is ready to receive data.

(8) Immediately depress the DATA button when the Sender carrier tone is heard. The DATA lamp shall light. Transmission begins when the Sender operator moves the reader control lever to the RUN position. The handset may now be placed in the cradle.

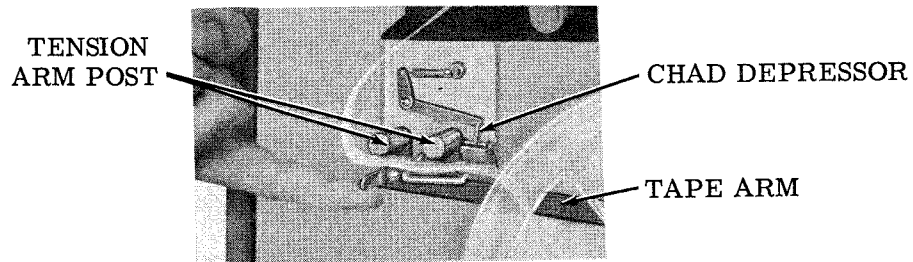
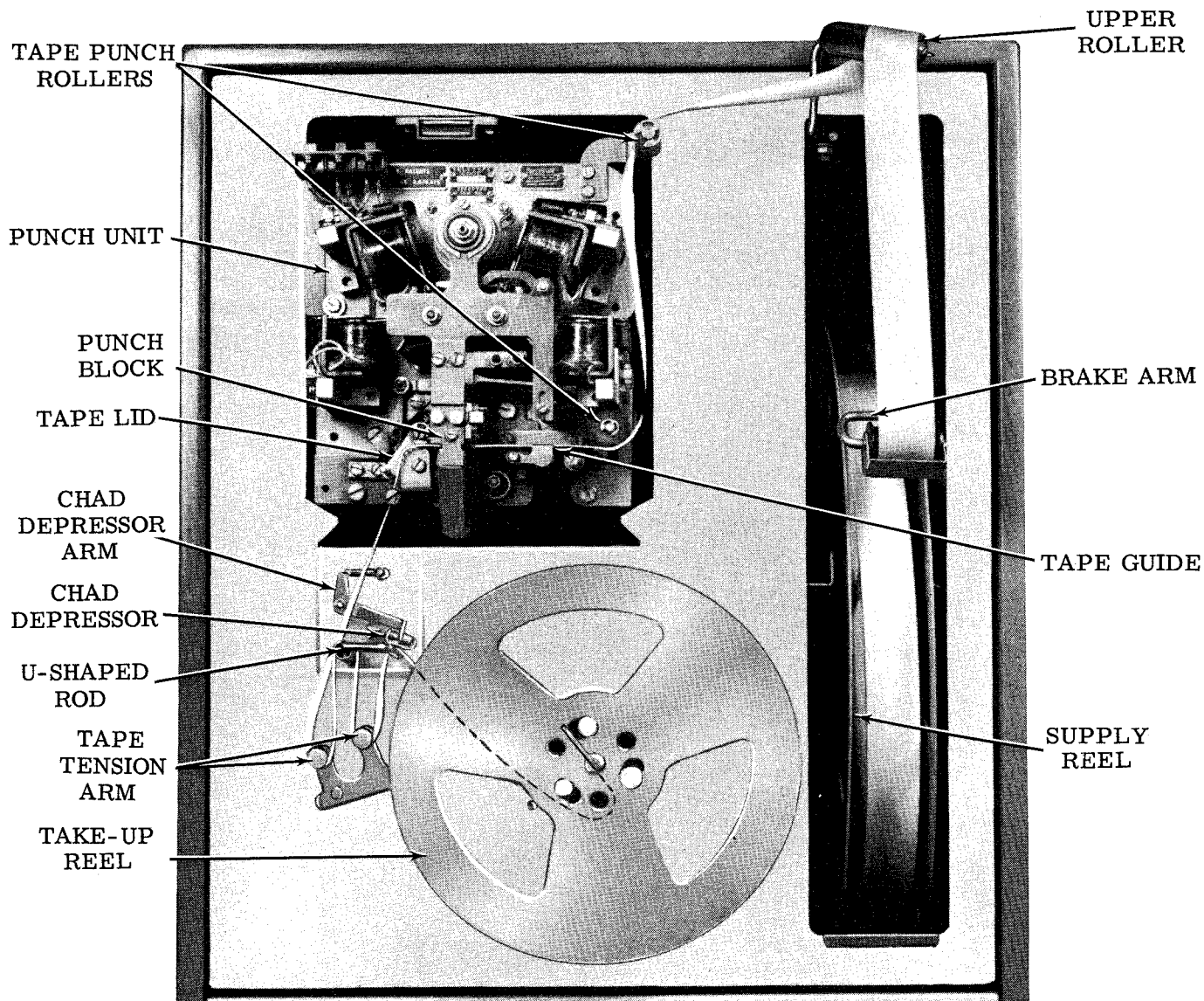

POSITION FOR TAPE THREADING

Figure 6 - Tape Path for Receiver Terminal

RECEIVER TAPE SUPPLY REEL ARRANGEMENTS

The Receiver tape supply reel can accommodate 11/16 inch, 7/8 inch, and 1 inch wide tape. To accept these various tape widths, however, the reel latches and retainers must be properly positioned.

(A) 11/16 INCH TAPE: Both latches must be on the low steps of the reel core. The tape reel retainers are placed on their respective shafts so that the retainer shoulders are facing away from the core.

(B) 7/8 INCH TAPE: One latch must be on a low step of the reel core, and the other on the opposite high step of the reel core. Place the tape retainers on their shafts so that the retainer shoulder of one is facing toward the reel core (latch on high step), and the shoulder of the other is facing away from the core (latch on low step).

(C) 1 INCH TAPE: Both latches must be on the high steps of the reel core. The tape reel retainers are placed on their respective shafts so that the retainer shoulders are facing toward the reel core.

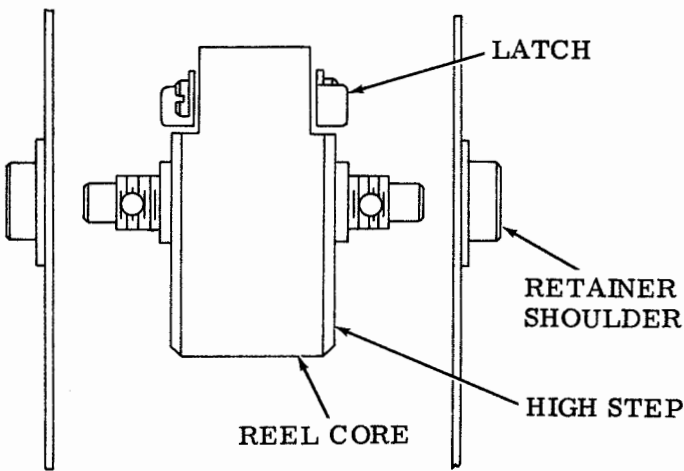

(A) 11/16 INCH TAPE

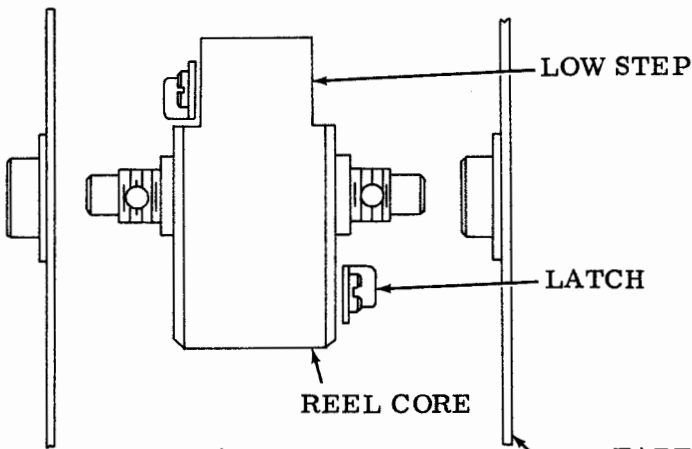

(B) 7/8 INCH TAPE

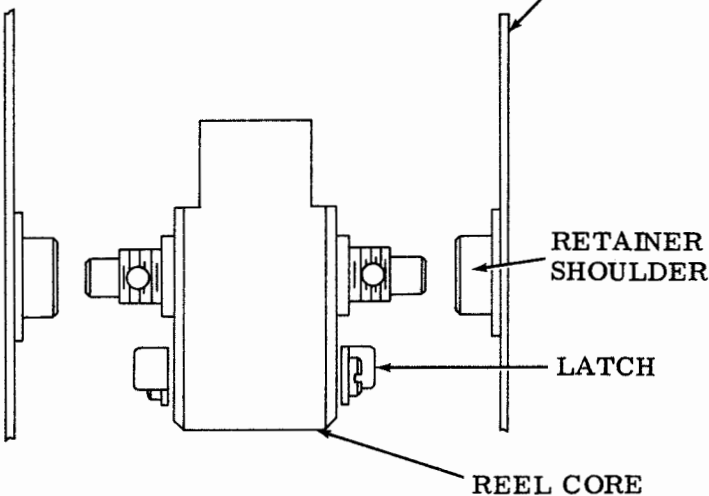

(C) 1 INCH TAPE

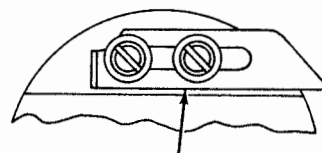

Note: Latches must be pushed forward to prevent the roll of tape from moving out of position.

Figure 7 - Receiver Terminal Tape Supply Reel Arrangements

(9) When the end of tape has been indicated, terminate the call as follows:

- (a) Depress the TALK button on the data set; lift the handset, and then hang up.
- (b) Operate the PUNCH and WINDER switches to stop the motors.

6.03 An end of message (EOM) may be indicated to the Receiver in either of the following ways:

- A prearranged pattern punched in the tape can be used to indicate end of transmission.
- A short pause in the transmission may be used. The talking path may be established again, if desired, or connection terminated.

6.04 A chad box, for collecting the small circular pieces of tape perforated from the tape roll, is located behind the front sliding panel below the tape punch motor unit.

CAUTION: EMPTY THE CHAD BOX EACH TIME A REEL OF TAPE HAS RUN THROUGH THE TAPE PUNCH.

- Units manufactured after about April, 1963, have a redesigned chad collection arrangement utilizing a cotton bag for storage of the chad pieces (Fig. 8). In addition, if chad should back up the chad chute, an overload device on the chute (directly beneath the tape punch block) releases to prevent chad from fouling the punch mechanism.

7. OPTIONAL FEATURES

TAPE SENDER

A. Signal Converter with Rubout Delete

7.01 The signal converter with rubout delete prevents the transmission of an all MARK signal from the tape sender terminal to the tape receiver terminal.

7.02 In certain data systems the operator, while preparing a message tape, may insert errors into the tape. To "erase" these mistakes, the errored characters are deleted

by punching all levels (rubout) of the entire group of characters involved. The correct message is then repunched into the tape in a new location.

7.03 When the tape is transmitted, the receiving station would normally receive all information sensed by the tape reader at the sending station, including all MARK or rubout characters. If, however, a sending signal converter with rubout delete is utilized at the sending station, the all MARK (rubout) signals will be suppressed. Consequently, only the valid data information will be reproduced at the tape receiver terminal.

7.04 The signal converter with rubout delete is a complete electronic module; the rubout delete feature alone is not available separately as a modification kit. No special manual procedures are necessary to operate terminals utilizing a signal converter with rubout delete.

B. Line Break and Automatic Answer

7.05 The transmitter line break and automatic answer kit is arranged to provide the unattended answer feature for the sender terminal of the high speed tape-to-tape system. It also provides a means whereby a Receiver operator can stop transmission and/or start the transmitter whether the Sender is in the manual or automatic answer condition.

7.06 Automatic Answer: The automatic operation of the transmitter terminal from a Receiver station is accomplished by the line break signal and the interlock signal derived from the data set. However, certain conditions must exist with regard to the following data set leads: ready, remote release, and remote control common outputs - see theory section. With these conditions satisfied, the unit will automatically answer a call and transmit a message. The Receiver operator (calling station) places a call in the normal manner. The transmitting station (called) will signal the operator (1200 cps tone) indicating the station has answered. The transmitter data set goes into DATA mode automatically and the Receiver operator starts the transmitter by depressing the DATA button on the 202A data set.

7.07 Line Break: The break feature in a high speed tape-to-tape system permits a Receiver location to interrupt the traffic in process for the purpose of correcting a taut tape condition or similar malfunction. This feature

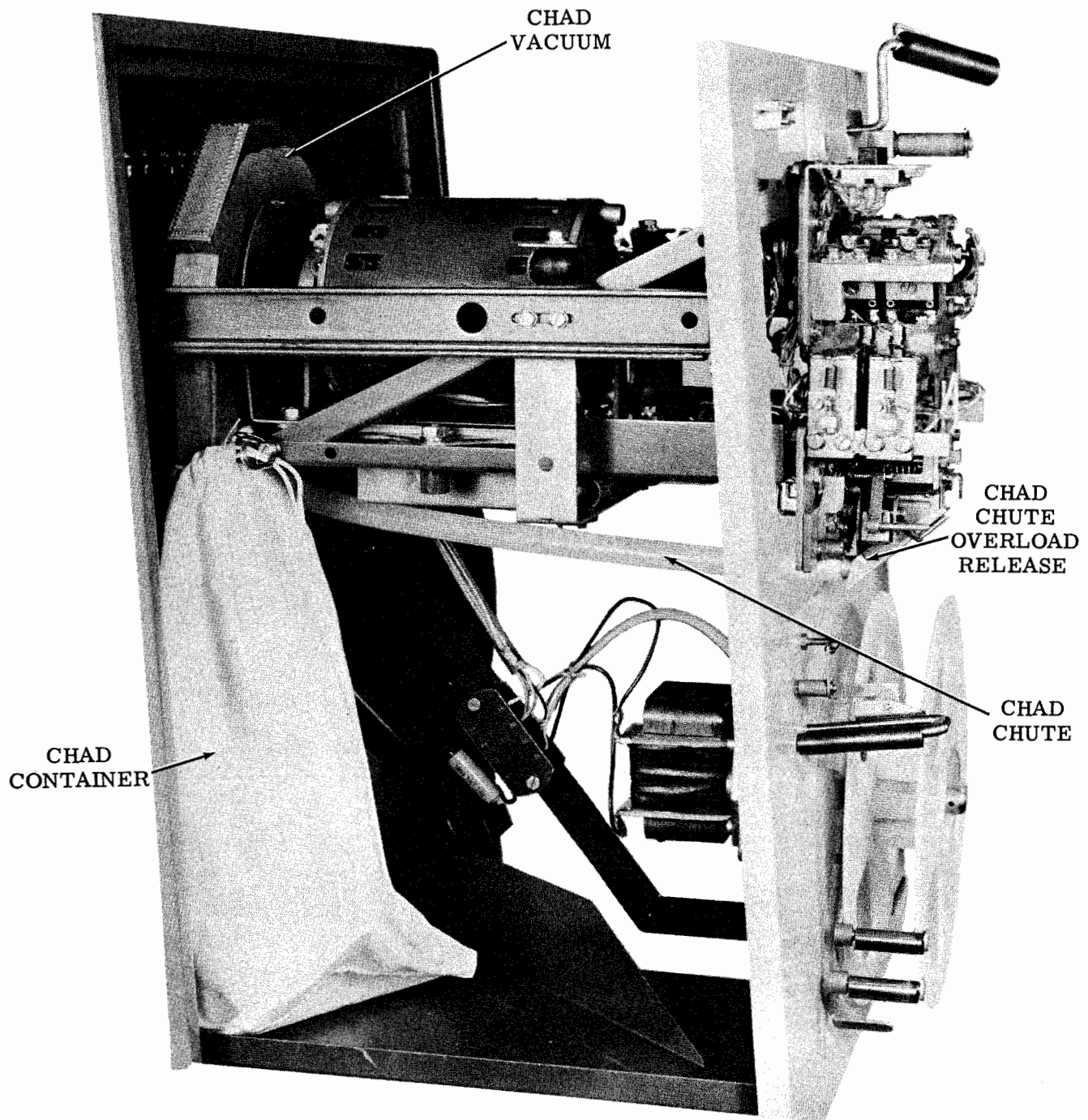

Figure 8 - Tape Receiver Chad Collection System

will cause the Sender and Receiver to stop operating, turn on the line break indicator and ring an audible alarm at the Sender station. The Receiver operator may stop the transmitter anytime during transmission of a message by depressing the TALK button on the Receiver data set with the telephone receiver off the hook. The transmitter will automatically stop and may be restarted by depressing the DATA button. During this procedure, the message content will be lost. The break feature is dependent upon the use of a data set having the reverse channel facilities - 202C2 and 202D2.

C. Interim Unattended Answer (Private Line)

7.08 An interim unattended answer kit (TP148161) was made available for use in tape sender terminals equipped with the line break and automatic answer kit mentioned in Paragraph 7.05. The purpose of this kit is to provide circuitry for automatically starting a sender terminal from a receiving terminal, without depending upon data set reverse channel carrier. A limitation of this approach is that the unattended transmitter may be triggered into action by an unauthorized Receiver. This kit is now used in private line applications only. The discrete calling modification kits for the Sender and Receiver locations (see 7.32) will supersede the early equipment.

D. Automatic Disconnect

7.09 The recognizer kit TP199551 must be used to provide for the automatic disconnect feature at the sending station. In certain applications, the central office does not send an on-hook signal to the called station. The automatic disconnect feature assures that the called unattended station will return to its on-hook condition after the call is terminated.

7.10 The automatic disconnect feature will place the data set of a send-only terminal in the on-hook condition after a thirty second interval when there is an absence of the carrier detect signal from the data set. Thus a disconnect will be provided when either of the following conditions exists: (a) failure to detect a transmitter start signal, (b) the end of transmission.

TAPE RECEIVER

A. Automatic Answer

7.11 Early tape-to-tape systems may provide automatic answer (TP146528) at receive terminals only. This feature, when used, allows the receive terminal to start automatically, re-perforate tape, and cutoff at the end of the message. This kit is superseded by the TP199593 modification kit - see Paragraph 7.16.

7.12 The Receiver is prepared for automatic answer by operating the AUTO button on the data set. At multiple installations, the 3-position switch of the transmit-receive (Y-connector) kit should be in the RECEIVE position (see Paragraph 7.20). With the Receiver in this condition, an incoming call will cause the data set to go into data mode and start the motors. An answer-back tone is sent back to the send terminal, indicating that the Receiver is ready to receive data. Since the incoming line at the receive station is open until the Sender starts transmitting, any noise transmitted on the line will cause garble to be punched into the tape. A message marker at the beginning and end of the message is necessary in order to distinguish the actual message from garble.

7.13 The originating call from a send terminal to a receive terminal with automatic answer is made in a manner similar to that for manual operation. When the answer-back tone from the Receiver is heard by the send operator, the following steps should be performed to start transmission:

- (1) Sender operator should cover the hand-set transmitter to prevent motor sounds, breathing, and other noises from punching garble in the received tape.
- (2) Start the reader and winder motors by operating the READER and WINDER switches.
- (3) Depress the DATA button on the data set.
- (4) Move the reader control lever to the RUN position.

7.14 To terminate the call from the send station:

- (1) Move the control lever to the STOP position.
- (2) Operate the READER and WINDER switches to stop the motors.

- (3) Depress the TALK button on the data set; lift the handset, and then hang up.

B. Resynchronizer Modification

7.15 A modification kit (TP148123) is available for 1B Tape Receivers not equipped with a resynchronizer. This circuit (furnished with 2B) will guarantee resynchronization of a tape receiver terminal with the incoming signal when an error has occurred due to a noise burst on the line. Positive resynchronization is achieved under random code structures or transmission conditions. No special manual procedures are necessary to operate units utilizing this feature.

C. Automatic Answer and Disconnect

7.16 The automatic answer kit (30 sec. time out - TP199593) is arranged for use at unattended Receiver locations to assure that the station will return to the on-hook condition at all times. The kit will automatically provide an unattended Receiver (all type 1B and 2B) with a start and disconnect feature. This modification kit replaces the existing automatic answer kit TP146528.

7.17 The (time out) kit will enable a type 202 data set to answer a call automatically when its control button labeled AUTO is depressed. When the Receiver goes into its DATA mode of operation, the tape punch motor and the tape handling drive motor are started. The tape punch is blinded (allowed to idle) until the carrier signal is received.

7.18 The automatic disconnect feature will place a data set on-hook after a thirty second interval in which the carrier detect signal is absent from the data set. Reliable disconnect operation necessitates the use of type 202C and 202D data sets having the improved carrier detector. Automatic disconnect procedure will occur on the following conditions: (a) wrong numbered calls, and (b) end of transmission.

7.19 The following operating procedures shall be followed:

- (1) Manual Operation - Do not depress the AUTO selector button on the data set.
- (2) Unattended Operation - Depress the AUTO selector button on the data set.

TAPE SENDER AND RECEIVER

A. Transmit-Receive Terminal Kit

7.20 The transmit-receive terminal ("Y" connector) kit (TP146532) provides a means of connecting a tape sender terminal and a tape receiver terminal located at the same installation — to a common model 202A or 202B data set. This feature allows both units to be serviced alternately by one data set.

7.21 Switching of the common data set from one terminal to the other terminal is facilitated by a three-position switch mounted on the front of the Tape Sender cabinet. Either terminal may be selected to operate with the data set. It is not possible, however, to operate both terminals at the same time.

7.22 When the break feature (7.27) is installed on units in the field having the early style "Y" connector cable (TP146532), refer to Paragraphs 2.06 through 2.10 of section entitled Type 1 and Type 2 Tape Senders and Receivers, Installation and Checkout Procedures for the required modifications. Certain changes in the terminal connections and the addition of a 2700 ohm resistor on the connectors of the high speed tape-to-tape system are required to provide the signal voltage for the reverse channel function of the data set. Certain data sets must be strapped for the "ZC" and "M" contact operation.

B. Send-Receive Terminal Connector Kit (Later Design)

7.23 The send-receive terminal connector kit (TP199610) will provide send-receive service from a single data set for a station consisting of a high speed Sender and a high speed Receiver. This feature is used with either the 2A or 2B high speed tape-to-tape system having either the 202A, 202B, 202C, or the 202D data sets.

7.24 The new send-receive "Y" connector is required where send-receive terminals are equipped with the discrete calling kit TP199550 and/or TP199551. The connector replaces the current TP146532 cable connector.

7.25 The terminal connector kit consists of a new "Y" connector cable, panels and a four-position switch located on the Sender panel to interconnect the Sender, the Receiver and the data set. The switch is used to select the desired mode of operation for the data set. The

rotary switch and the data set are located above the deck of the Sender. The four positions of the control switch are as follows:

- SEND - Manual or Discrete (Unattended) Transmitting
- RECEIVE - Manual or Unattended Receiving
- SEND/RECEIVE - Discrete Transmitting or Receiving
- TEST - Terminal Testing (two-wire transmission)
Manual or Unattended Transmitting and Receiving (four-wire transmission)

C. Optional Auxiliary Equipment

7.26 The following optional equipment is available for use with the sender and receiver terminals.

- (a) Data Test Set 905A and 905B (TSG801 and 800): Signal generators specifically designed for system testing. The 905A (TSG801) is a rack mounted model, and the 905B (TSG800) a portable unit.
- (b) Signal Monitor 9555s: An oscilloscope for use with Tape Senders or Receivers. Stores on the upper right module rack in the lower enclosure of the cabinets.
- (c) Tape Winder TW203: Self-contained motor driven tape winder. Reel capacity is 650 feet of fully perforated tape, and 325 feet of chadless tape. Accommodates 11/16 inch, 7/8 inch, and 1 inch tape. Operates at speeds from 60 wpm to 628 wpm.
- (d) Modification Kit TP146626: Converts a TW200 tape winder to accept a TP145911 plastic reel.
- (e) Tape Winder TP146821: Self-contained, spring driven tape winder. Reel capacity is 350 feet of fully perforated tape, and 170 feet of chadless tape. Accommodates 11/16 inch, 7/8 inch and 1 inch tape. Operates at speeds up to 1000 wpm.
- (f) Modification Kit TP146882: Converts spring driven tape winders TP115739, TP115753, TP115754 and TP123587 to accept a TP145911 plastic tape reel.
- (g) Reel Adapter TP146698: To increase the diameter of a TP145911 plastic tape reel from 1-15/16 inches to 3-1/4 inches. For

transfer of accumulated message tape to center unwind reel TP146892.

- (h) Reel Adapter TP146806: To increase the diameter of a TP145911 plastic tape reel from 1-15/16 inches to 4-1/2 inches. For transfer of accumulated message tape to business machine reels.
- (i) Outside Unwinder TP146892: Outside "pay-out" unwinder to feed any offline equipment. Accepts TP145911 plastic tape reel.
- (j) Center Unwinder TP146815: Center-unwind reel designed to feed a tape reader at speeds up to 100 wpm. Capacity is 1800 feet of fully perforated, and 1000 feet of chadless tape. Accepts 11/16 inch, 7/8 inch, and 1 inch tape.
- (k) Tape Winder TW17: Self-contained high speed tape winder. Capacity is 3000 feet of fully perforated and 2000 feet of chadless tape. Accepts 11/16 inch, 7/8 inch, and 1 inch tape. Operates at speeds up to 2000 wpm.
- (l) Tape Splicer 28A: For splicing unpunched tape.
- (m) Tape Splicer 1A: For splicing chadless tape.
- (n) Card Carrying Case TP146538: To provide means for transporting the etched circuit cards used to maintain the sender and receiver terminals. Capacity of 42 etched circuit cards plus one test extension card.

SYSTEM FEATURES

A. Break Feature

7.27 The break feature enables a Receiver location to interrupt the traffic in process when an alarm condition occurs (low, taut tape, etc) or a condition where the circuit continuity is lost. The signaling in the opposite direction is accomplished over a separate reverse channel frequency. The essential elements required to furnish the break feature have been incorporated within the Tape Senders and Receivers. Data sets 202C2 and 202D2 provide the capabilities for the break feature when minor modification of the high speed tape-to-tape system is arranged.

7.28 Tape-to-tape systems using the TP146532 "Y" connector will require a slight modification of the connector that plugs into the data set. The change will be required at the sender as well as the receiver terminal. No changes are required in type 1A and 1B or type 2A and 2B send-receive terminals equipped with the discrete calling kits TP199550 and TP199551. Refer to the Type 1 and Type 2 Tape Senders and Receivers, Installation and Checkout Procedure section.

7.29 With the advent of the 202C2 and the 202D2 data sets, incorporating the reverse channel feature, and with minor modifications made at both the Sender and Receiver locations the facilities mentioned above are compatible. Transmission is stopped automatically if circuit continuity is lost or the Receiver operator may interrupt transmission because of low tape, etc by pressing the data set TALK button. Note that sending stations in systems arranged for the break feature can only transmit to Receivers also equipped with this feature. Modify the send-receive terminal as referenced in 7.28.

Sender

7.30 The line break and automatic answer kit (TP146527) is a required item at the sender terminal to provide for the interim unattended answer kit, the line break feature, or the discrete calling kit - see 7.33. This line break feature will not function with data sets of early design since reverse channel facilities are required to perform the function. However, the line break kit (TP146527) has been installed in the Sender cabinet and held in an inactive state by its OPERATE/TEST switch until the required data set facilities are made available.

- This switch must be in the TEST position until facilities are available for its use. (See Paragraph 7.08.)

7.31 The line break and automatic answer feature, when provided, allows a tape sender terminal to answer calls and transmit data unattended. It also allows the receive station to signal the send station during transmission. The operator at the receive station does this by lifting the telephone handset and operating the TALK button on his data set. This causes the Sender and Receiver to stop operating, lights a LINE BREAK lamp, and rings a bell at the send station. When this condition is detected at the

send station, the operator should lift his handset and operate the data set TALK button. The voice path will then be established.

Receiver

7.32 A positive six-volt potential is required at the receiver's termination to the data set for the automatic answer and line break feature. Refer to the installation section for the slight modifications needed to generate the reverse channel signal to the sender terminal where it is detected and used to activate the break feature.

B. Discrete Calling

General

7.33 The Tape Sender recognizer kit (TP199551) is used in conjunction with a Tape Receiver generator kit (TP199550 at receiver terminal) to provide priority measures for the start and disconnect command. This feature guards against the possibility that unauthorized stations may call the unattended transmitter by mistake and force its Sender to spill the intelligence stored in tape. A discrete character must be generated by the attended receiving location and recognized by the unattended sending station before any tapes can be transmitted.

7.34 The protection feature is obtained by a coded start signal being generated by a slow moving disc at the remote receiving station on the command of the operator. This signal is then sent to the tape sender recognizer at the transmitter having the scheduled traffic in its reader. The start signal is examined by the recognizer, bit by bit, and if the mechanism determines that the signal is identical with its assigned signal code the traffic is put on the line. Thus, a Receiver will not start a Sender unless the Receiver is properly authorized to receive the data. Note that all character generating discs (15 elements) in a customer's systems must be coded identically.

Sender

7.35 The recognizer kit (TP199551) provides the protected transmitter start feature and the automatic disconnect function for the Sender. Sets equipped with this accessory will send only to properly authorized Receivers. This accessory is used with a send-receive terminal kit (TP199610) to provide unattended operation of send-receive terminals.

7.36 The automatic disconnect feature will place the data set of a send-only terminal or a send-receive terminal "on hook" after thirty seconds of absence of "carrier detect" from the data set. Thus disconnects will be provided on the following conditions: (a) failure to detect transmitter start signals and (b) the end of a transmission.

7.37 The following operating procedures shall be followed to prepare a high speed Sender for unattended service:

- (1) Terminal power ON.
- (2) Reader loaded with tape.
- (3) Reader control switch in RUN position.
- (4) Automatic-manual switch in AUTO position.
- (5) Depress AUTO button on the associated 202C data set.

Receiver

7.38 The Tape Receiver generator kit (TP199550) is used in conjunction with the remote Sender recognizer kit (TP199551) described in 7.35. An identification signal is generated at the Receiver location and transmitted to the unattended Sender of the tape-to-tape system for a comparison with its generator output. The 14-bit character (discrete) signal is sensed by the Sender and the tape Reader turned on when a valid identification signal is recognized.

7.39 The identifier module (TP199552) for the receiver terminal produces a low speed, start-stop signal having discrete timing. The removable coding disc (TP199580) enables the control engineer to assign the coding character by which all stations involved in the project will be identified. The discs are coded by using a screwdriver or diagonal cutter to break certain etched wiring patterns. All discs in a customer's system are coded identically.

