

symbol of leadership

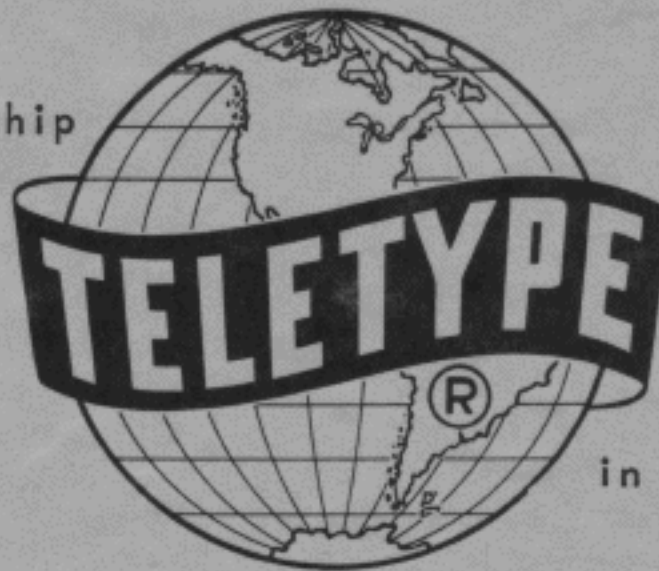

in printing telegraphy

BULLETIN 1113B

PARTS

PORTABLE SIGNAL DISTORTION TEST SET

(ED51 & ED58)

TELETYPE[®]

CORPORATION

SUBSIDIARY OF *Western Electric Company* INC.

CHICAGO, ILLINOIS, U. S. A.

symbol of leadership



in printing telegraphy

BULLETIN 1113B

PARTS

PORTABLE SIGNAL DISTORTION TEST SET

(ED51 & ED58)

TELETYPE[®]

CORPORATION

SUBSIDIARY OF *Western Electric Company* INC.

CHICAGO, ILLINOIS, U. S. A.

LIST OF EFFECTIVE PAGES

APRIL, 1959

(Supersedes August, 1955 issue)

Page Number	Change In Effect
A to C	Change 1
1 TO 9	Change 1

The above list indicates the effective pages as of the date of issue. Upon receipt of change pages, insert them numerically and discard any superseded pages.

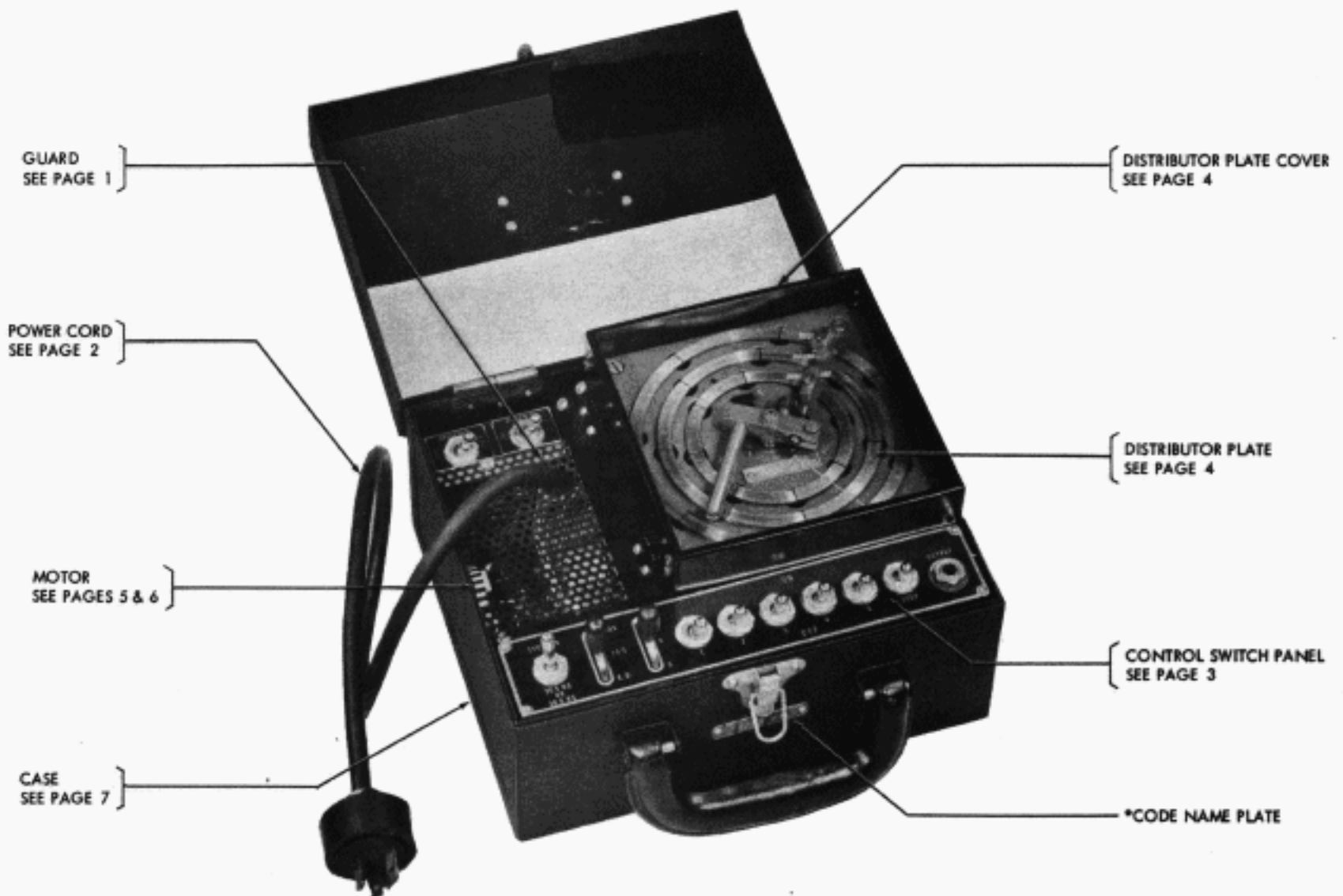

PORTABLE SIGNAL DISTORTION TEST SET
(ED58HE ILLUSTRATED)

VARIATIONS IN PORTABLE SIGNAL DISTORTION TEST SETS CATALOGED HEREIN		
DESCRIPTION	UNITS	
	ED51	ED58
FILTER (DISTRIBUTOR BRUSHES)	NO	YES
FILTER (POWER LEADS)	NO	YES
LOCATION OF MOTOR SWITCH	IN POWER CORD	ON THE UNIT
TYPE OF MOTOR USED	SYNCHRONOUS (115 VOLT A.C. - 50 OR 60 CYCLES)	GOVERNED (115 VOLT A.C. - 25 TO 65 CYCLES)
ASSOCIATED MOTOR ARRANGEMENTS (INCLUDES GEAR AND PINION) <small>See pages 5 and 6 for assembly numbers</small>	"EH" FOR 368 O.P.M. (50 CYCLES) "JU" FOR 404 O.P.M. (50 CYCLES) "EG" FOR 460 O.P.M. (50 CYCLES) "DT" FOR 368 O.P.M. (60 CYCLES) "DS" FOR 460 O.P.M. (60 CYCLES) "HN" FOR 600 O.P.M. (60 CYCLES)	"HE" FOR 368, 460 OR 600 O.P.M. (25 TO 65 CYCLES)
WIRING DIAGRAM NUMBER	1954WD	2403WD

*ALL UNITS ARE IDENTIFIED BY THE SIX CHARACTER CODE STAMPED ON THE CODE NAME PLATE.
FOR EXAMPLE: ED58HE

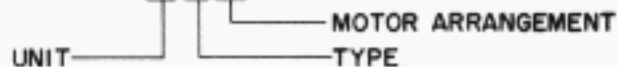

ALPHABETICAL INDEX

DESCRIPTION	PAGE NO.	DESCRIPTION	PAGE NO.
Base Plate - - - - -	1	Governed Motor Arrangement - - - - -	6
Brushes - - - - -	4	Guards - - - - -	1
Cable - - - - -	2	Jacks - - - - -	3
Capacitors - - - - -	1,5,6	Keys - - - - -	3
Case - - - - -	7	Motors - - - - -	5,6
Chart, Gear - - - - -	1,5	Motor Arrangements - - - - -	5,6
Circuit Label - - - - -	7	Name Plates - - - - -	6,7
Control Switch Panel - - - - -	3	Pinions - - - - -	5,6
Distributor Parts - - - - -	4	Plugs - Cords - - - - -	2
Filter, Power Leads - - - - -	6	Power Cords - - - - -	2
Fuse Holder and Choke Coil - - - - -	2	Resistors - - - - -	6
Fuse Parts - - - - -	1	Switches, Toggle - - - - -	3,6
Fuses - - - - -	1,2	Synchronous Motor - - - - -	5
Gears - - - - -	5,6	Synchronous Motor Arrangement - - - - -	5
Gear Chart - - - - -	1	Target - - - - -	6
Gear Holder - - - - -	1	Terminal Block - - - - -	6
Governed Motor - - - - -	6	Toggle Switches - - - - -	3,6

BELL SYSTEM ONLY

When ordering parts from this bulletin,
prefix each number with the letters TP.

TELETYPE TO BELL SYSTEM CODE DESIGNATION

TELETYPE CODEBELL SYSTEM CODE

*ED51DT

100A TELETYPEWRITER TEST DISTRIBUTOR (INCLUDES 60 CYCLE
SYNCHRONOUS MOTOR AND SET OF GEARS FOR 368 O.P.M.)

*ED51EH

100C TELETYPEWRITER TEST DISTRIBUTOR (INCLUDES 50 CYCLE
SYNCHRONOUS MOTOR AND SET OF GEARS FOR 368 O.P.M.)

* UNITS FURNISHED TO BELL SYSTEM WILL HAVE CODE NAME PLATES WITH BELL SYSTEM
DESIGNATION INSTEAD OF TELETYPE DESIGNATION AS SHOWN ON PAGE B OF THIS BULLETIN.

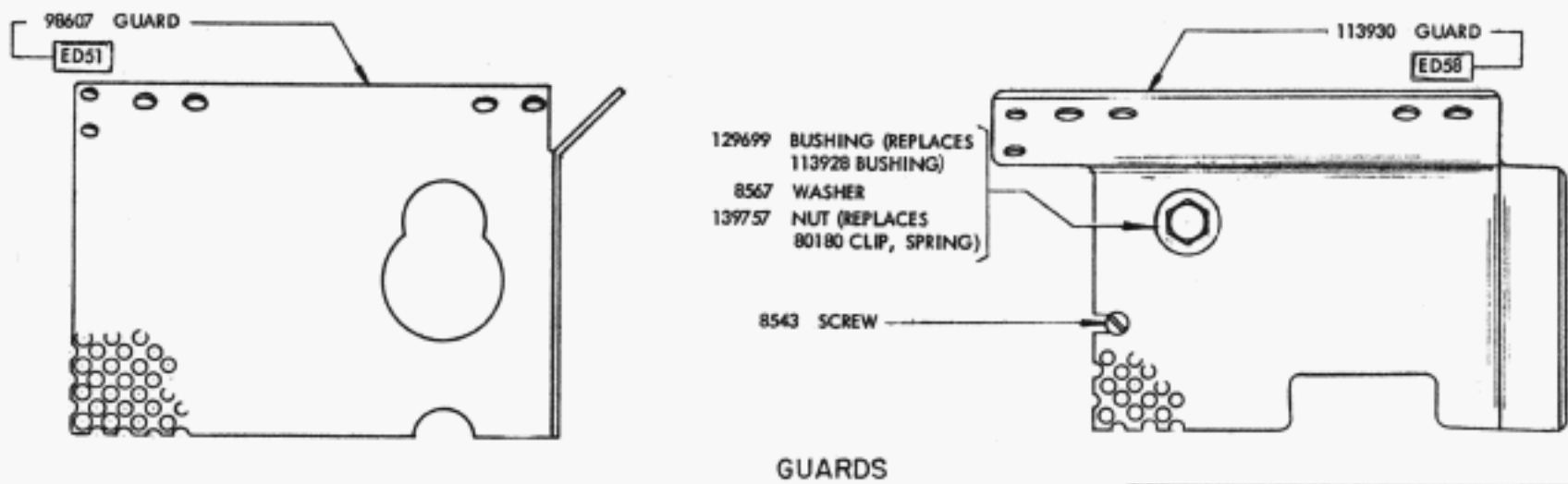
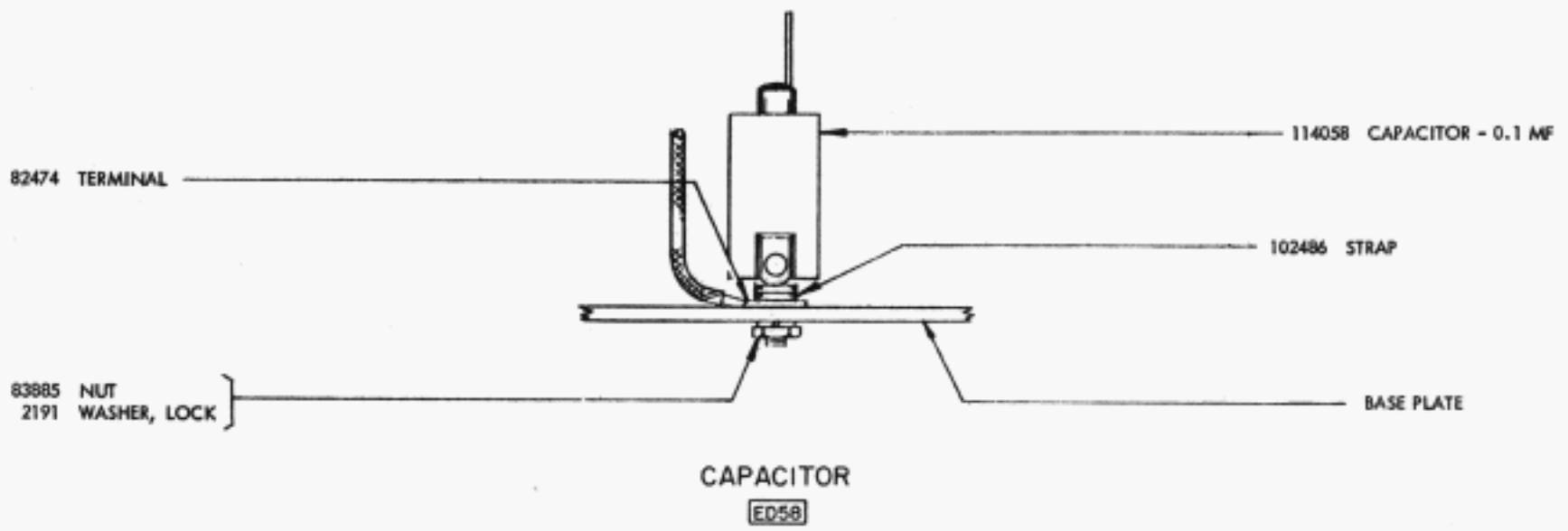
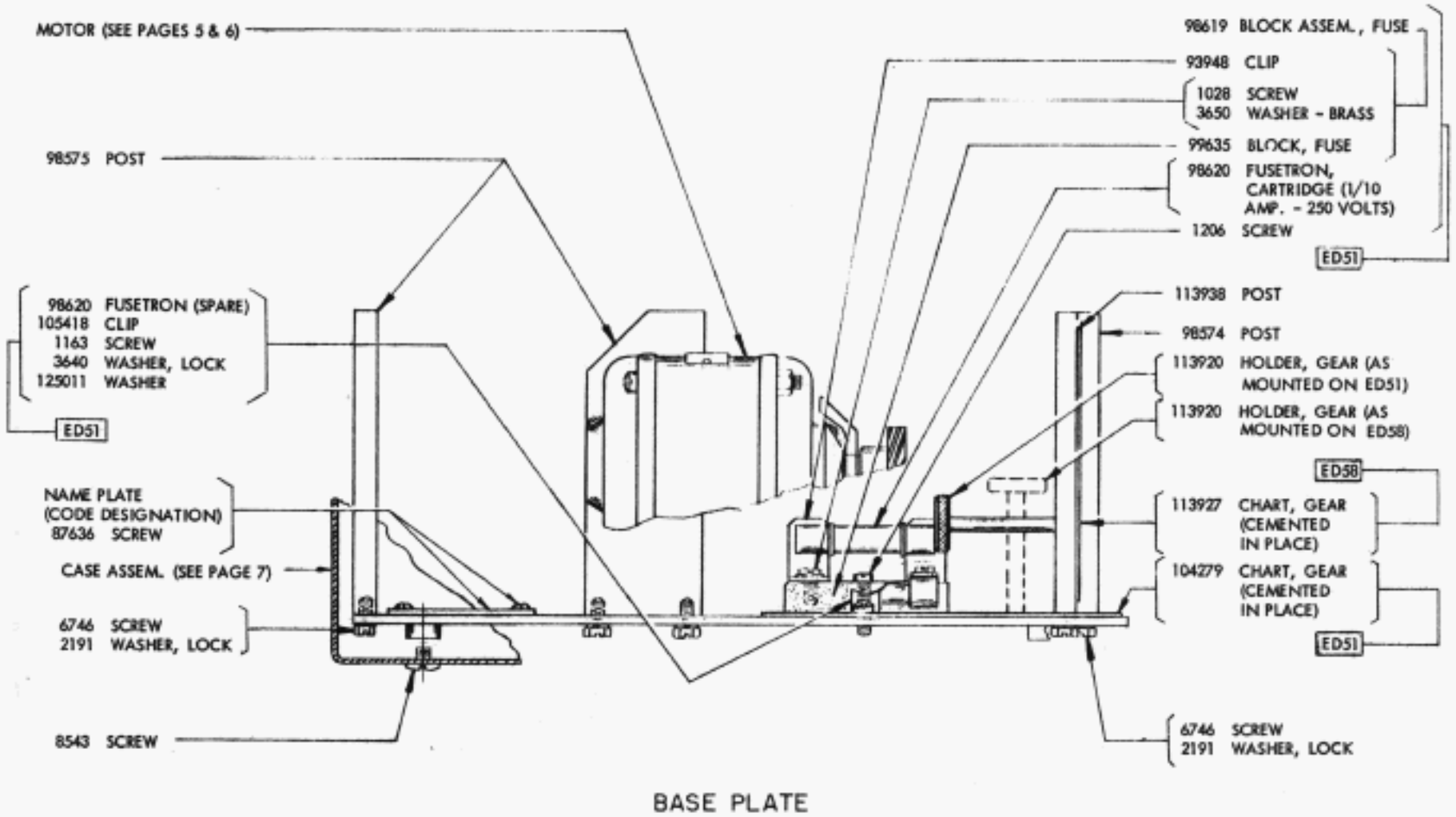

UNLESS OTHERWISE SPECIFIED ALL PARTS SHOWN ABOVE ARE COMMON TO ED51 AND ED58.

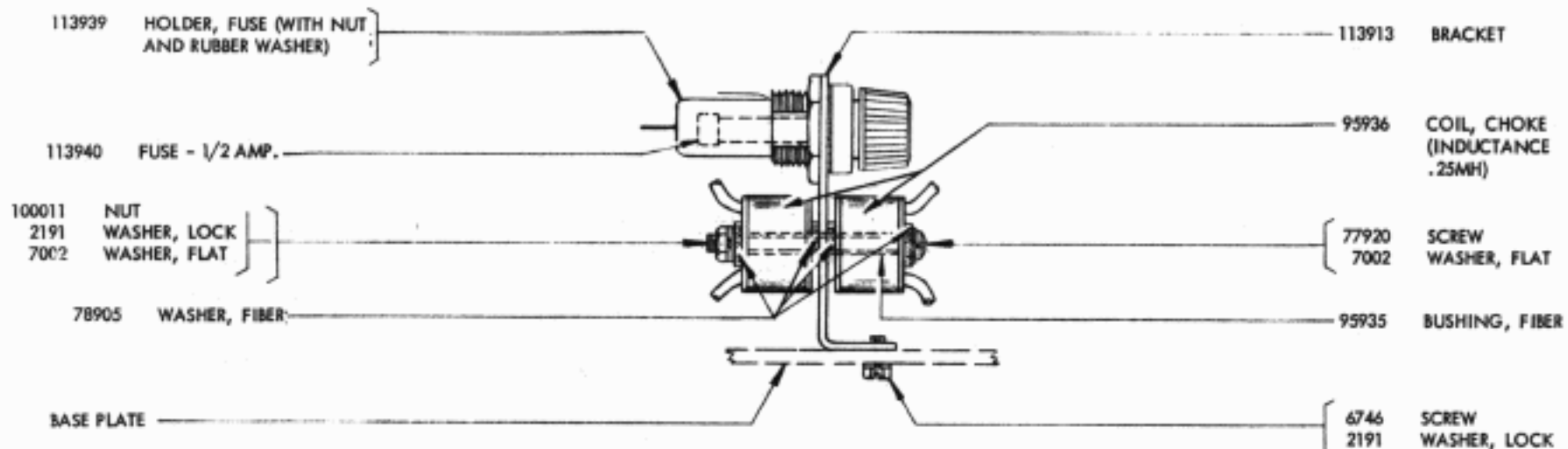

113937 FUSE AND COIL BRACKET ASSEMBLY

ED58

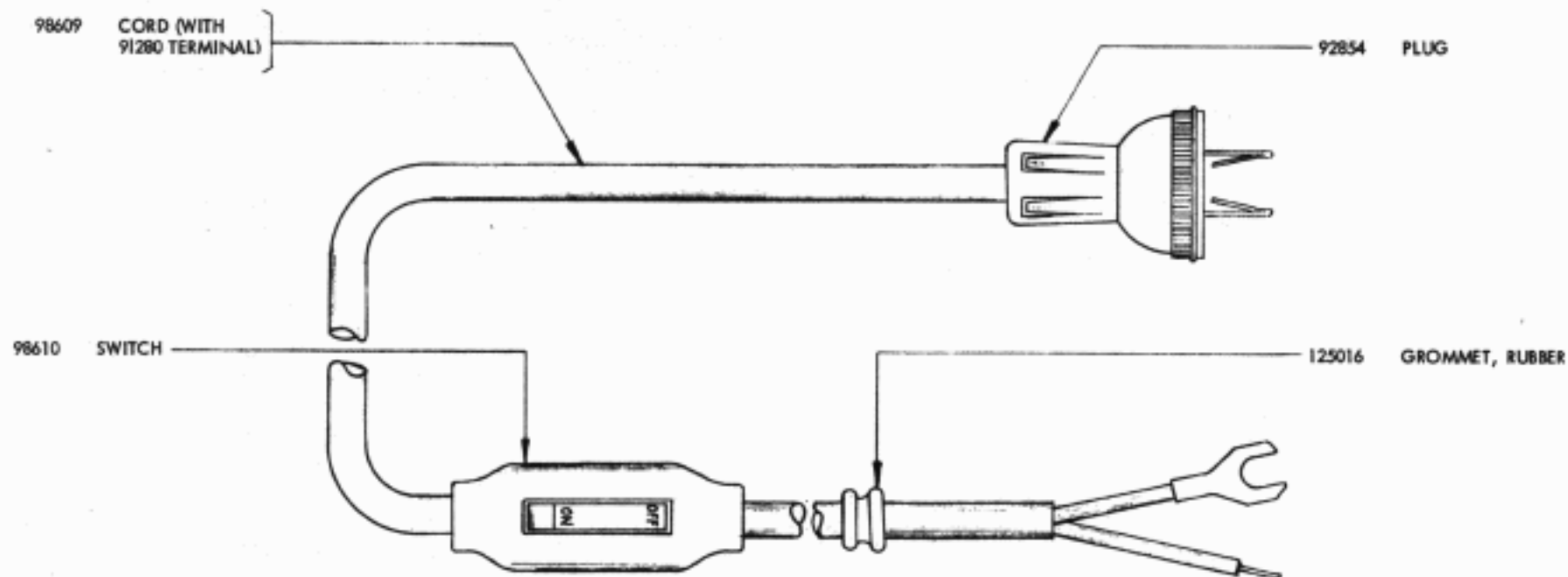

98608 POWER CORD ASSEMBLY
(APPROX. 70" LONG)

ED51

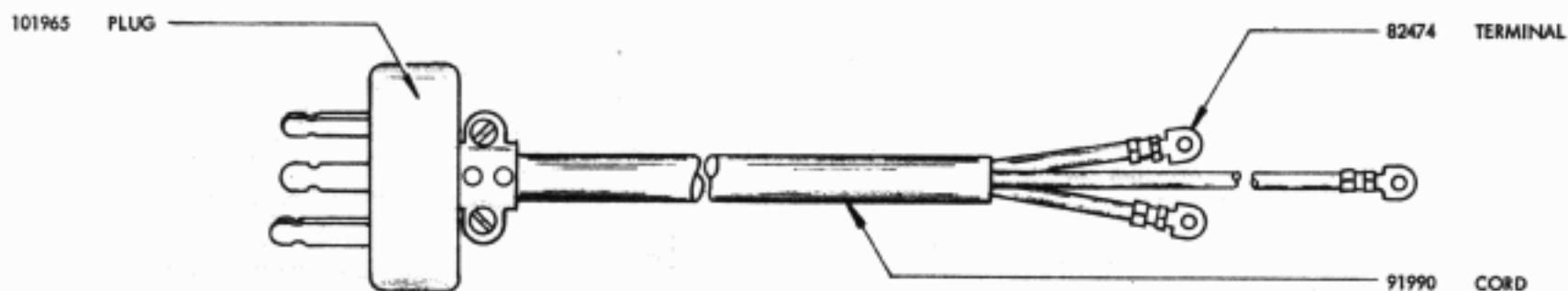

98075 POWER CORD ASSEMBLY
(APPROX. 30" LONG)

ED58

(See chart on Page B for associated wiring diagram)

120426 CABLE
ED51 & ED58

120427 CABLE
ED58

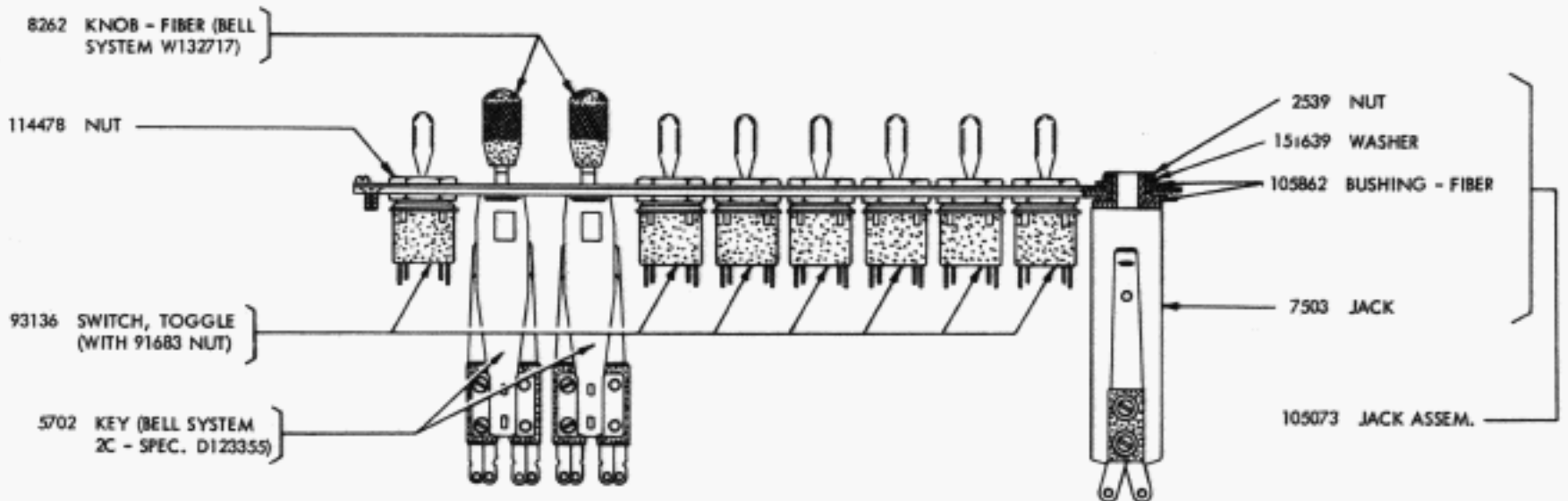
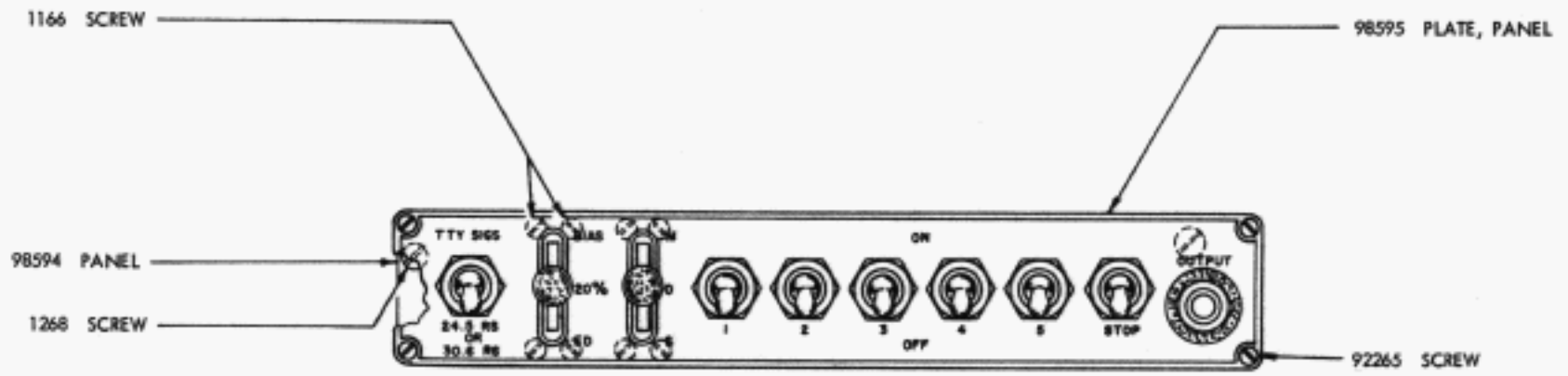

CONTROL SWITCH PANEL

ED51 & ED58

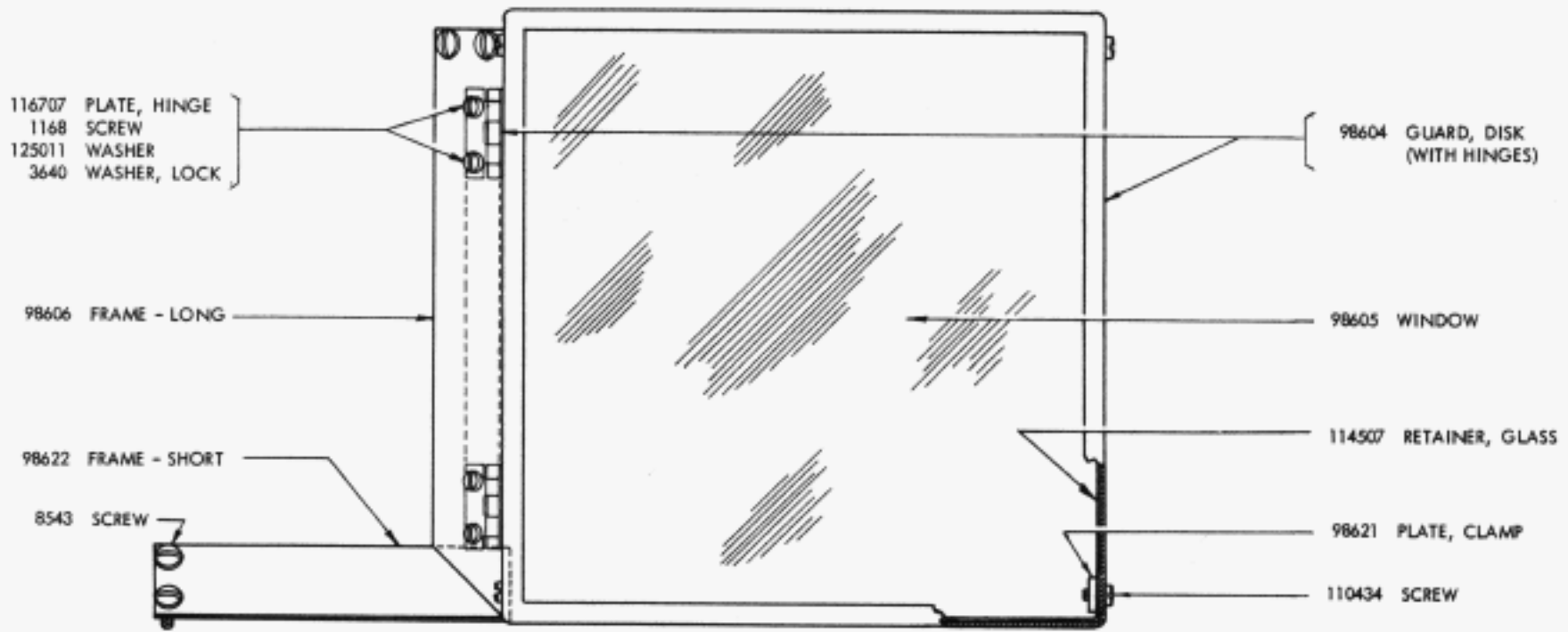

DISTRIBUTOR PLATE COVER

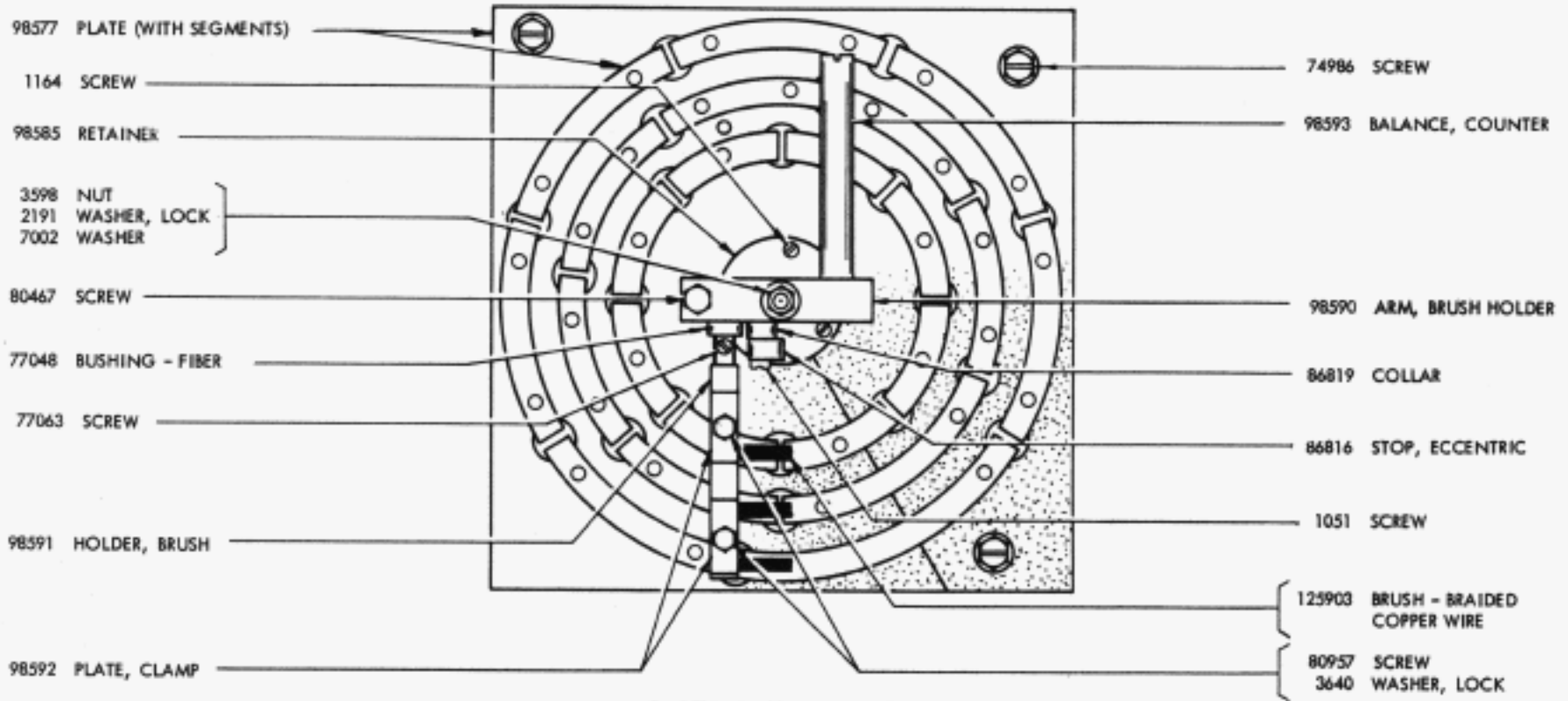

DISTRIBUTOR PLATE

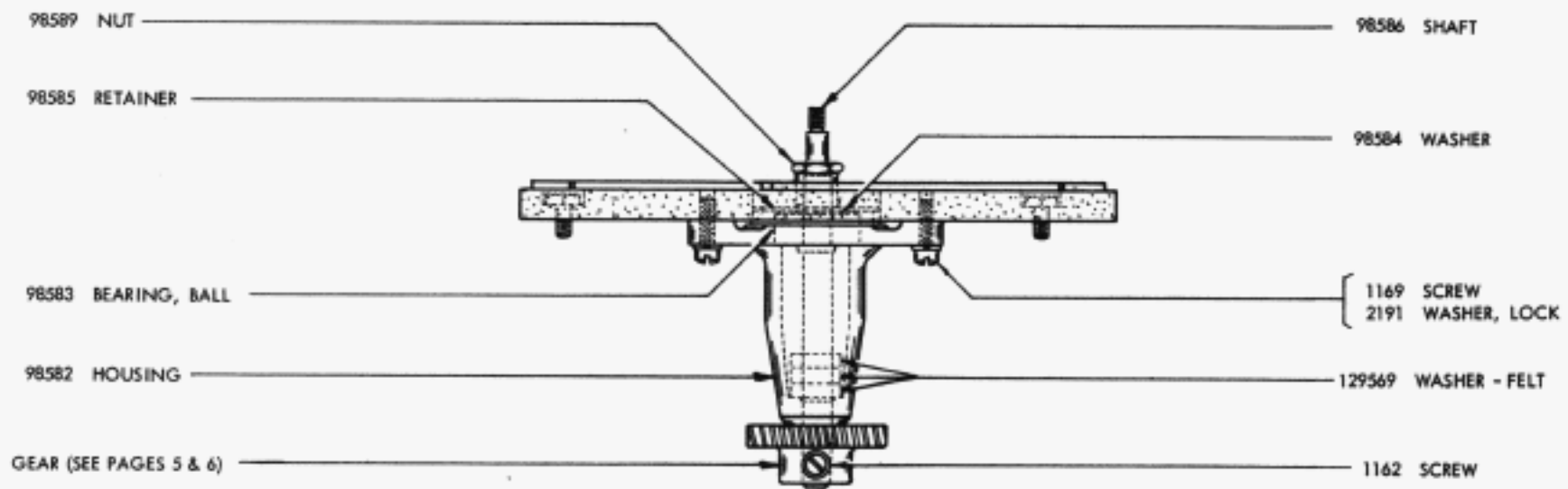

DISTRIBUTOR PLATE HOUSING

ALL PARTS SHOWN ABOVE ARE COMMON TO ED51 AND ED58.

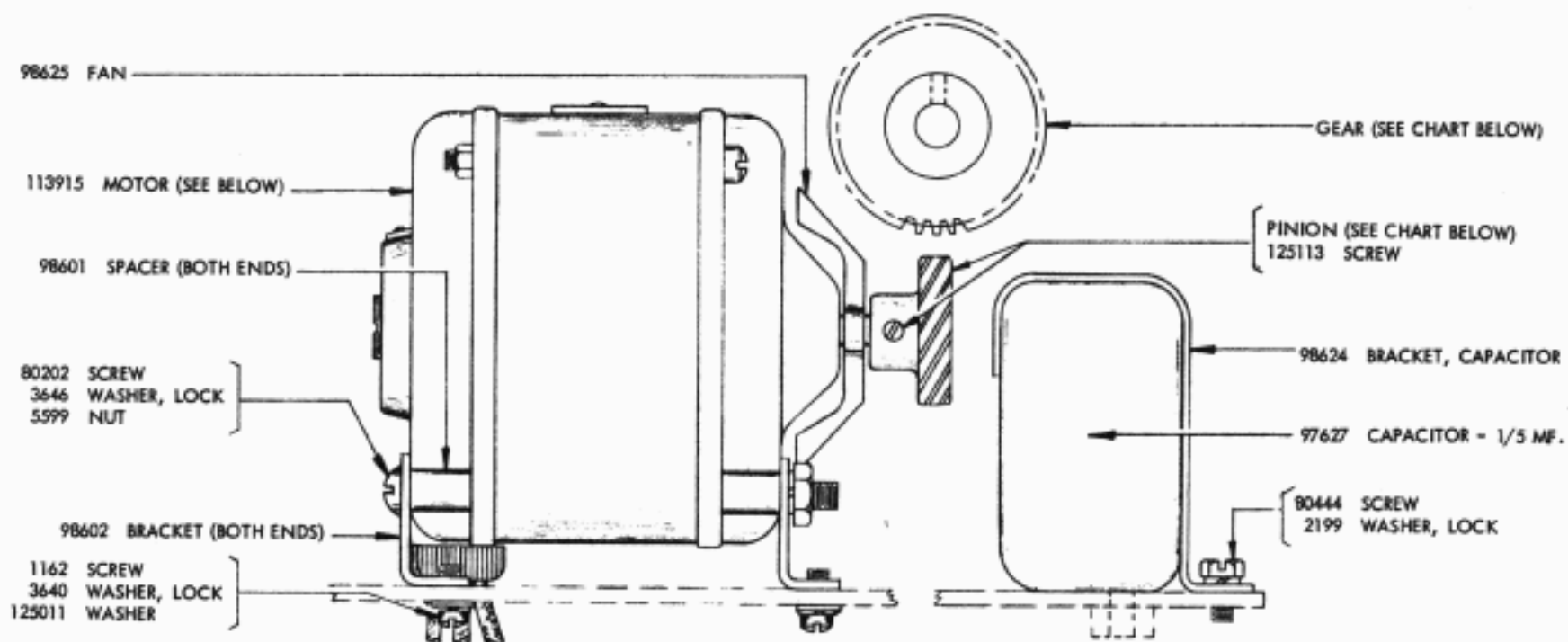

GEAR CHART						
FREQUENCY OF POWER SOURCE-CPS	50	50	50	60	60	60
W.P.M.	60	65	75	60	75	100
O.P.M.	368	404	460	368	460	600
MOTOR R.P.M.	1500	1500	1500	1800	1800	1800
PINION	101849 (12T)	118855 (7T)	101847 (12T)	98626 (9T)	98603 (12T)	113887 (12T)
GEAR	101848 (49T)	118854 (26T)	101846 (39T)	98627 (44T)	98587 (47T)	113886 (36T)
PINION & GEAR SET NUMBER	101851	118857	101850	99177 (BELL SYSTEM 100A)	98597 (BELL SYSTEM 100B)	113885 (BELL SYSTEM 100C)
MOTOR ARRANGEMENT	102006 (EH)	119769 (JU)	102005 (EG)	99294 (DT)	99295 (DS)	114100 (HN)

SYNCHRONOUS MOTOR ARRANGEMENTS

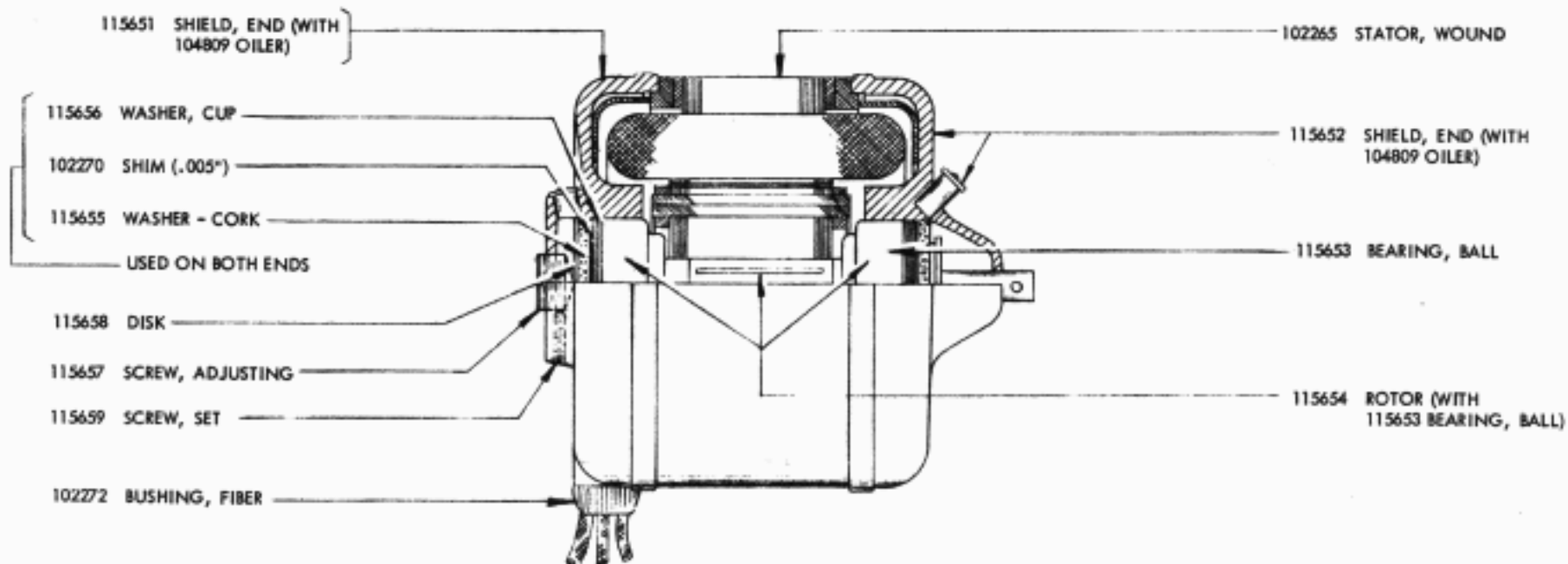

113915 A.C. SYNCHRONOUS MOTOR
115 VOLT, 50/60 CYCLE (H.C. MODEL S-9064)

ALL PARTS SHOWN ABOVE
ARE PECULIAR TO ED51.

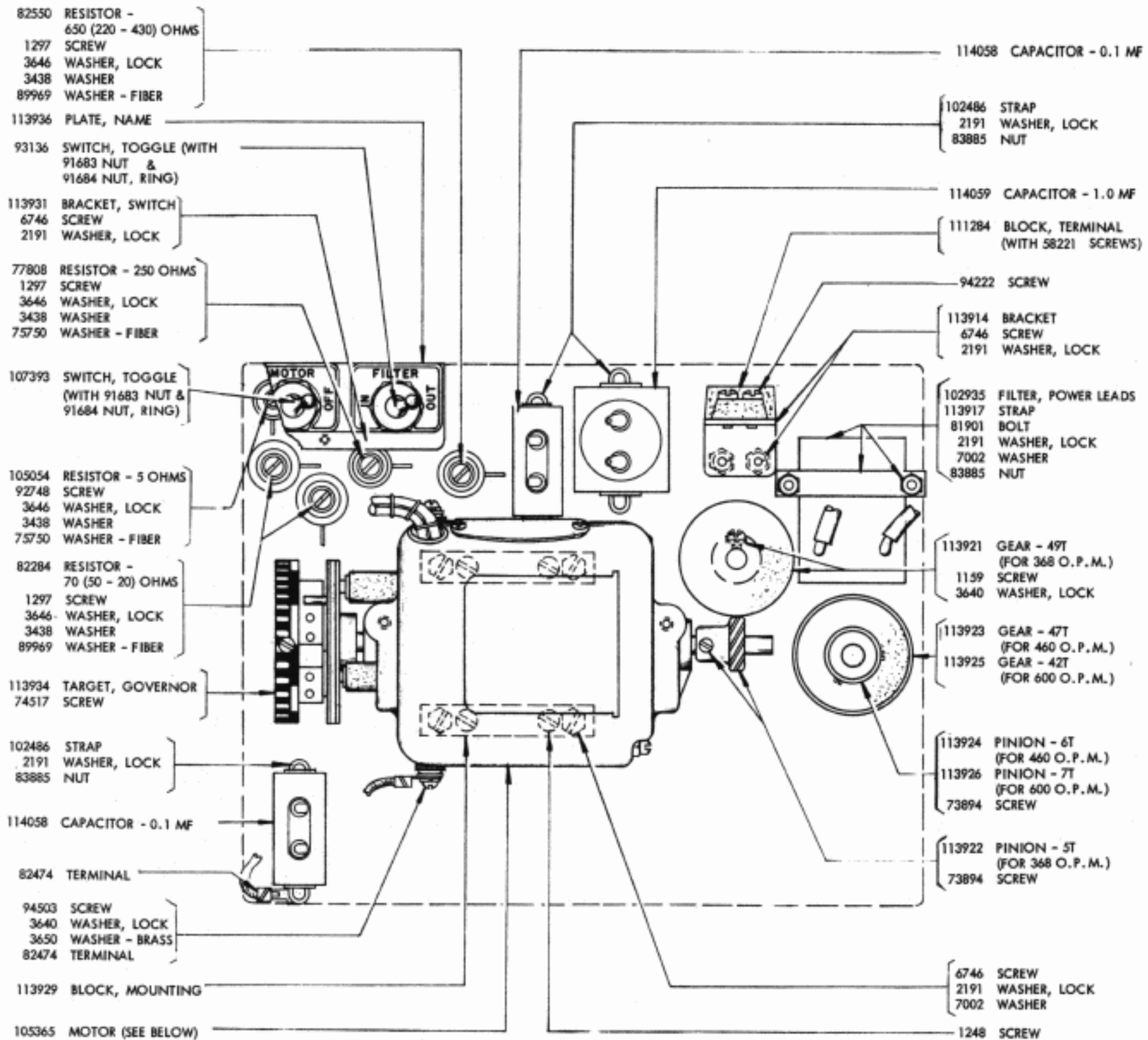

113910 (HE) GOVERNED MOTOR ARRANGEMENT
 (INCLUDES SETS OF GEARS FOR 368, 460 AND 600 O.P.M.)

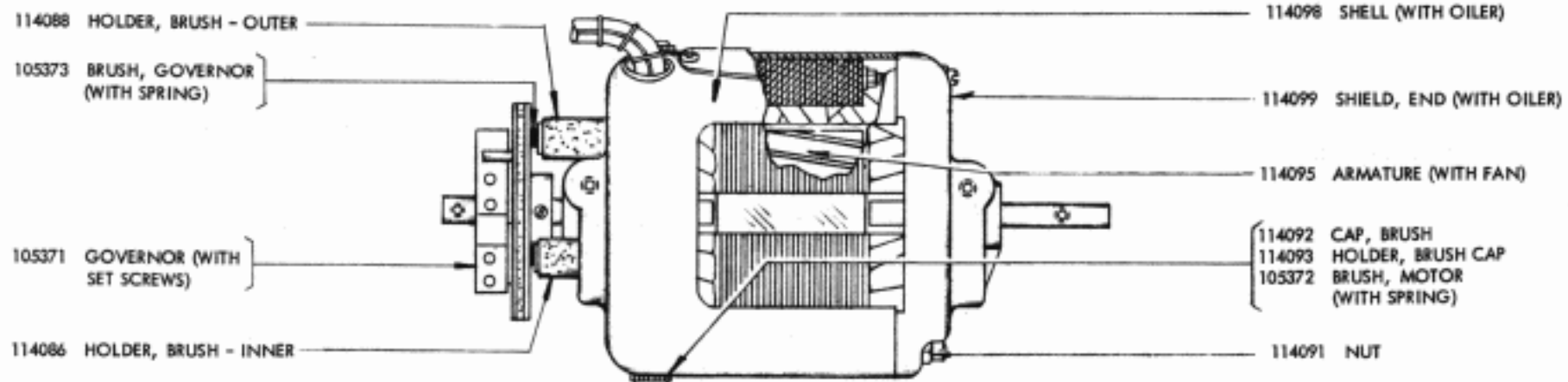

105365 A.C. GOVERNED MOTOR
 1/60 H.P., 115 VOLT, 60 CYCLE (G.E. MODEL 5BA36EA57)

ALL PARTS SHOWN ABOVE ARE PECULIAR TO ED58.

1113B

98611 HINGE

98612 SCREW

NAME PLATE (PROPERTY)
87636 SCREW
112627 NUT

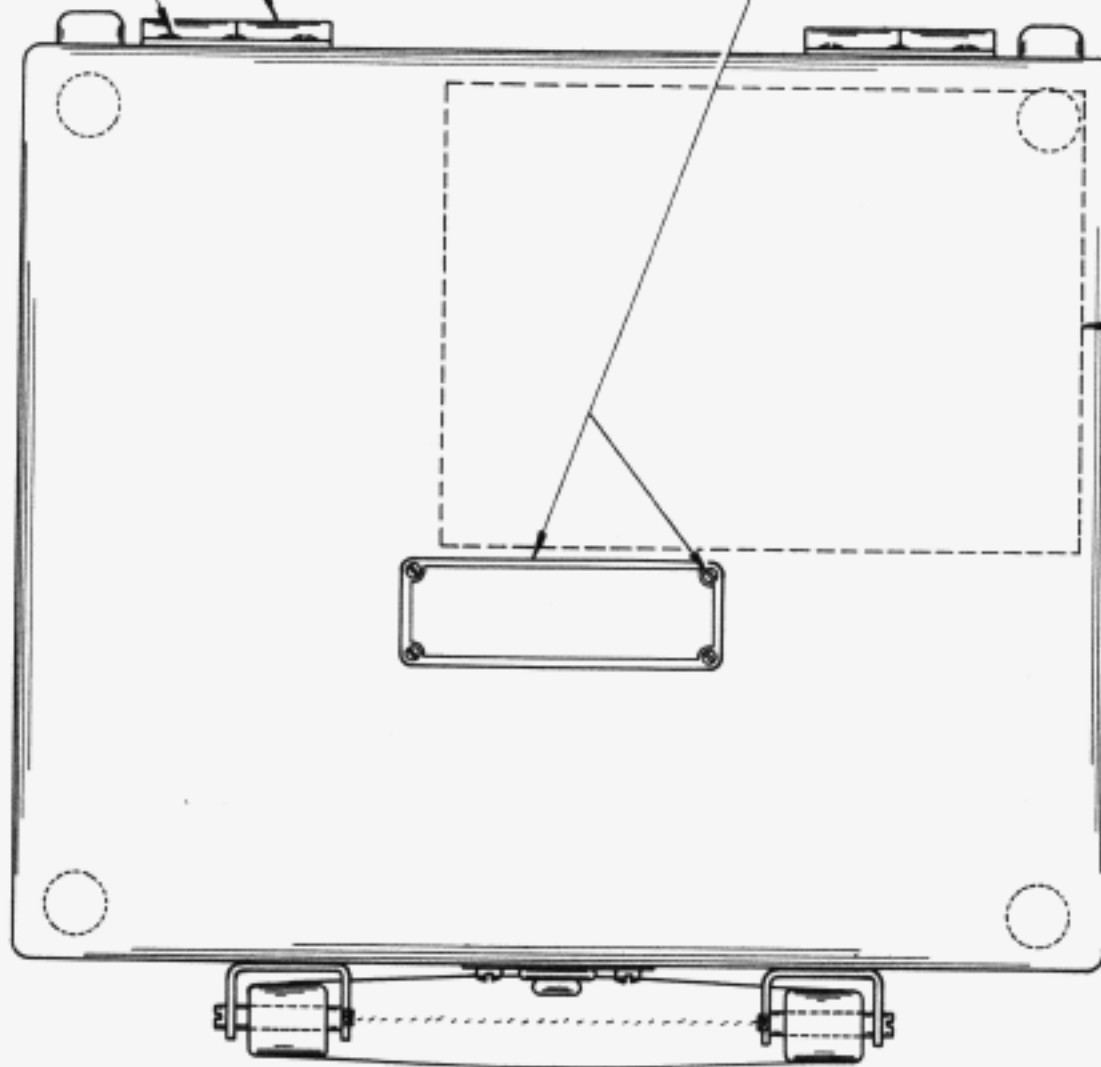

ED51
102456 LABEL, CIRCUIT
113919 LABEL, CIRCUIT
ED58
(CEMENTED IN PLACE ON
UNDERSIDE OF COVER)

98617 CATCH

125139 SCREW

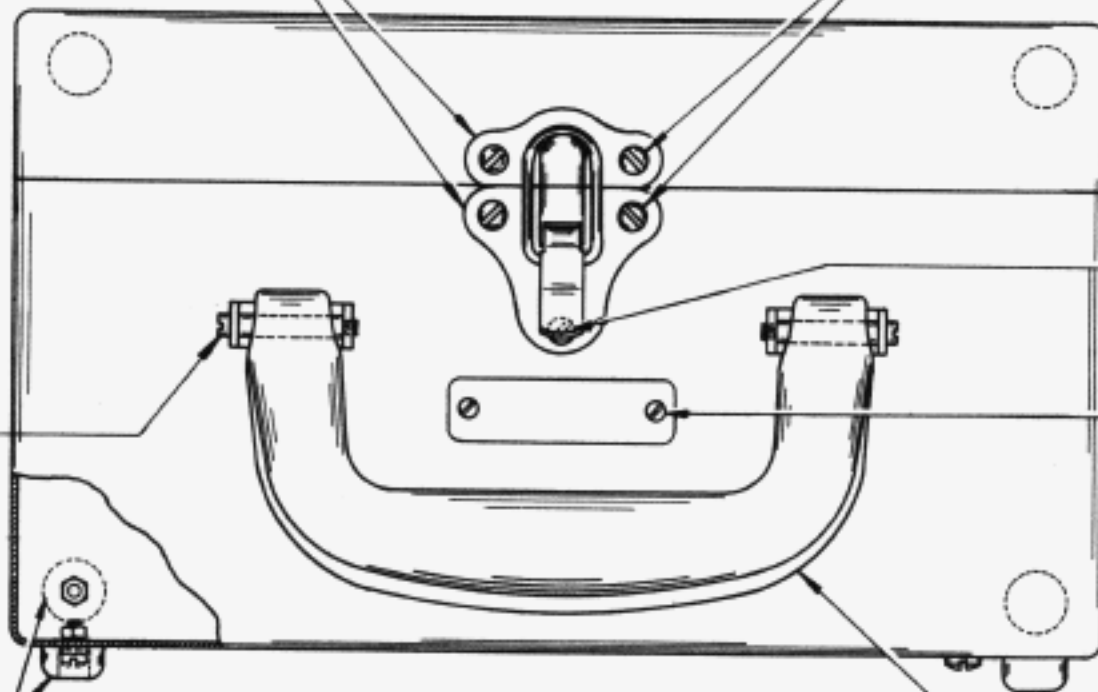

110434 SCREW
110435 NUT

NAME PLATE
(CODE DESIGNATION)
87636 SCREW
112627 NUT

98616 PIN

98615 HANDLE - LEATHER

78469 FOOT - RUBBER
1162 SCREW
41675 WASHER
110435 NUT

98613 CASE ASSEMBLY - BLACK WRINKLE

UNLESS OTHERWISE SPECIFIED ALL PARTS
SHOWN ABOVE ARE COMMON TO ED51 AND ED58.

NUMERICAL INDEX

Numbers following the description indicate the page.

Part Number	Description	Part Number	Description
1028	Screw (4-40 x 1/4 Fil) 1	92265	Screw (2-56 x 1/8 RD) 3
1051	Screw (4-40 x 1/2 Fil) 4	92748	Screw (6-40 x 1-7/16 Fil) 6
1159	Screw (4-40 x 3/8 Fil) 6	92854	Plug 2
1162	Screw (4-40 x 1/4 Fil) 4, 5, 7	93136	Switch, Toggle 6
1163	Screw (4-40 x 3/16 Fil) 1	93948	Clip 1
1164	Screw (2-56 x 3/16 Fil) 4	94222	Screw (6-40 x 3/8 Fil) 6
1166	Screw (4-36 x 1/4 Flat) 3	94503	Screw (4-40 x 5/16 RD) 6
1168	Screw (4-40 x 5/16 Fil) 4	95935	Bushing - Fiber 2
1169	Screw (6-40 x 7/16 Fil) 4	95936	Coil, Choke 2
1206	Screw (4-40 x 9/16 Fil) 1	97627	Capacitor - 1.5 MF 5
1248	Screw (6-40 x 1/2 Flat) 6	98075	Cord Assem., Power 2
1268	Screw (6-40 x 5/16 Flat) 3	98574	Post 1
1297	Screw (6-40 x 2-7/16 Fil) 6	98575	Post 1
2191	Washer, Lock 1, 2, 4, 5, 6	98577	Plate (with segments) 4
2539	Nut (3/8-32 Hex) 3	98582	Housing 4
3438	Washer 6	98583	Bearing, Ball 4
3598	Nut (6-40 Hex) 4	98584	Washer 4
3640	Washer, Lock 1, 4, 5, 6	98585	Retainer 4
3646	Washer, Lock 5, 6	98586	Shaft 4
3650	Washer - Brass 1, 6	98587	Gear - 47T 5
5599	Nut (8-32 Hex) 5	98589	Nut (1/4-32 Spec.) 4
5702	Key (Bell System 2C-spec. D123355) 3	98590	Arm, Brush Holder 4
6746	Screw (6-40 x 5/16 Hex) 1, 2, 6	98591	Holder, Brush 4
7002	Washer 2, 4, 6	98592	Plate, Clamp 4
7503	Jack 3	98593	Balance, Counter 4
8262	Knob - Fiber (Bell System W132717) 3	98594	Panel 3
8543	Screw (6-40 x 1/4 Fil) 1, 4	98595	Plate, Panel 3
8567	Washer 1	98597	Set of Gears (Bell System 100B) 5
41675	Washer 7	98601	Spacer 5
58821	Screw (6-32 x 1/4 Fil) 6	98602	Bracket 5
73894	Screw (6-40 x 1/8 Set) 5, 6	98603	Pinion - 12T 5
74517	Screw (6-40 Set) 6	98604	Guard, Disk 4
74986	Screw (6-40 x 13/32 Hex) 4	98605	Window 4
75750	Washer - Fiber 6	98606	Frame - Long 4
77048	Bushing - Fiber 4	98607	Guard 1
77063	Screw (4-40 Spec.) 4	98608	Cord Assem., Power 2
77808	Resistor - 250 OHMS 6	98609	Cord 2
77920	Screw (6-40 x 1-15/16 Fil) 2	98610	Switch 2
78469	Foot - Rubber 7	98611	Hinge 7
78905	Washer - Fiber 2	98612	Screw (4-40 x 3/16 Oval) 7
80180	Clip, Spring 1	98613	Case Assem. 7
80202	Screw (8-32 x 2-1/2 RD) 5	98615	Handle - Leather 7
80444	Screw (6-40 x 1/4 Hex) 5	98616	Pin (6-40 Spec.) 7
80467	Screw (6-40 x 3/8 Hex) 4	98617	Catch 7
80957	Screw (4-40 x 1/4 Hex) 4	98619	Block Assem., Fuse 1
81901	Bolt (6-32 x 3 RD) 6	98620	Fusetron, Cartridge 1
82250	Resistor - 650 OHMS 6	98621	Plate, Clamp 4
82284	Resistor - 70 OHMS 6	98622	Frame - Short 4
82474	Terminal 1, 2, 6	98624	Bracket, Capacitor 5
83408	Screw (4-40 x 3/16 RD) 1	98625	Fan 5
83885	Nut (6-32 Hex) 1, 6	98626	Pinion - 9T 5
86816	Stop, Eccentric 4	98627	Gear - 44T 5
86819	Collar 4	99177	Set of Gears (Bell System 100A) 5
87636	Screw (2-56 x 3/16 RD) 7	99294	Motor Arrangement 5
89969	Washer - Fiber 6	99295	Motor Arrangement 5
91280	Terminal 2	99635	Block, Fuse 1
91683	Nut (15/32-32 Hex) 3,6	100011	Nut (6-40 Hex) 2
91684	Nut (15/32-32 Ring) 6	101846	Gear - 39T 5
91990	Cord 2	101847	Pinion - 12T 5

NUMERICAL INDEX

Numbers following the description indicate the page.

Part Number	Description	Part Number	Description
101848	Gear - 49T 5	114091	Nut 6
101849	Pinion - 12T 5	114092	Cap, Brush 6
101850	Set of Gears 5	114093	Holder, Brush Cap 6
101851	Set of Gears 5	114095	Armature 6
101965	Plug 2	114098	Shell 6
102005	Motor Arrangement 5	114099	Shield, End 6
102006	Motor Arrangement 5	114100	Motor Arrangement 5
102265	Stator, Wound 5	114478	Nut (15/32-32 Hex) 3
102270	Shim (.005") 5	114507	Retainer, Glass
102272	Bushing - Fiber 5	115651	Shield, End 5
102456	Label, Circuit 7	115652	Shield, End 5
102486	Strap 1, 6	115653	Bearing, Ball 5
102935	Filter, Power Leads 6	115654	Rotor 5
104279	Chart, Gear 1	115655	Washer - Cork 5
104809	Oiler 5	115656	Washer, Cup 5
105054	Resistor - 5 OHMS 6	115657	Screw, Adjusting (5/8-24 Spec.) 5
105072	Switch, Toggle 3	115658	Disk 5
105073	Jack Assem. 3	115659	Screw (2-56 x 3/16 Set) 5
105365	Motor 6	116707	Plate, Hinge 4
105371	Governor 6	118854	Gear - 26T 5
105372	Brush, Motor 6	118855	Pinion - 7T 5
105373	Brush, Governor 6	118857	Set of Gears 5
105418	Clip 1	119769	Motor Arrangement 5
105862	Bushing - Fiber 3	120426	Cable 2
107393	Switch, Toggle 6	120427	Cable 2
110434	Screw (4-40 x 3/16 Fil) 4, 7	125011	Washer 1, 4, 5
110435	Nut (4-40 Hex) 7	125016	Grommet - Rubber 2
111284	Block, Terminal 6	125133	Screw (6-40 x 11/64 Set) 5
112627	Nut (2-56 Hex) 7	125139	Screw (4-40 x 1/8 Fil) 7
113885	Set of Gears (Bell System 100C) 5	125903	Brush - Braided Copper Wire 4
113886	Gear - 36T 5	129569	Washer - Felt 4
113887	Pinion - 12T 5	129699	Bushing 1
113910	Motor Arrangement 6	139757	Nut (7/16-32 Hex) 1
113913	Bracket 2		
113914	Bracket 6		
113915	Motor 5		
113917	Strap 6		
113919	Label, Circuit 7		
113920	Holder, Gear 1		
113921	Gear - 49T 6		
113922	Pinion - 5T 6		
113923	Gear - 47T 6		
113924	Pinion 6T 6		
113925	Gear - 42T 6		
113926	Pinion - 7T 6		
113927	Chart, Gear 1		
113928	Bushing 1		
113929	Block, Terminal 6		
113930	Guard 1		
113931	Bracket 6		
113934	Target, Governor 6		
113936	Plate, Name 6		
113938	Post 1		
113939	Holder, Fuse 2		
113940	Fuse 2		
114058	Capacitor - 0.1 MF 1, 6		
114059	Capacitor - 0.1 MF 6		
114086	Holder, Brush 6		
114088	Holder, Brush 6		