

BULLETIN 281B
VOL. 1

TECHNICAL MANUAL
MODEL 35
KEYBOARD SEND-RECEIVE (KSR) AND
RECEIVE-ONLY (RO)
TELETYPEWRITER SETS



TELETYPE[®]
CORPORATION
5555 TOUHY AVENUE, SKOKIE, ILLINOIS

281B
VOLUME 1

INTRODUCTION

Bulletin 281B is a technical manual that provides descriptive, installing and maintenance information for the Model 35 Keyboard Send-Receive (KSR) and Receive-Only (RO) Teletypewriter Sets and their components. Change 6 is issued to provide information on the UCC39 Call Control Unit.

The Bulletin consists of two volumes. Volume 1 contains description and operation, installation, lubrication, and disassembly and reassembly. Volume 2 contains adjustments.

Each volume is made up of a group of appropriate independent sections. They are separately identified by title and section number, and the pages of each section are numbered consecutively, independent of other sections.

The identifying number of a section, a 9-digit number, appears at the top of each page of the section, in the left corner of the left-hand pages and the right corner of the right-hand pages. The sections are placed in the manual in ascending numerical order.

To locate specific information refer to the table of contents on the following page. Find the name of the involved component in column one and the title of the section in column two. The correct 9-digit section number will then be found in column three. Turn to page one of the section indicated, where the contents of that section will be found (except where a section is small and does not require a listing of contents).

The sections comprising this bulletin are now stocked separately and may be individually ordered if the entire bulletin is not needed.

TABLE OF CONTENTS

FILING INSTRUCTIONS

1. The following filing instructions apply to changes sent to the field.
2. Asterisk (*) in the table of contents indicate changes. Double asterisk (**) indicates existing material newly added to bulletin.
3. When the issue of a section changes, replace the old issue with the attached new one.
4. In the case of addendums, turn to the affected section and follow the instructions on the first page of the attached addendum.
5. Replace the old table of contents with the new one.

Note: For information on UCC39 Call Control Unit, see Section 574-123-103TC.**

<u>Equipment</u>	<u>Title</u>	<u>Section</u>	<u>Issue</u>
Teletypewriter Set (KSR, RO)	Description and Operation	574-201-100TC	4
Teletypewriter Set (KSR, RO)	Installation	574-201-200TC	1
Typing Unit (LP)	Description and Operation	574-220-100TC	4
Typing Unit (LP)	Lubrication	574-220-701TC	4
Typing Unit (LP)	Disassembly and Reassembly	574-220-702TC	1
Keyboard and Base (LK, LB)	Description and Operation	574-221-100TC	4
Keyboard and Base (LK, LB)	Lubrication	574-221-701TC	3
Keyboard (LK)	Disassembly and Reassembly	574-221-702TC	1
Electrical Service Unit (LESU)	Description and Operation	574-226-100TC	4
Call Control Unit (LCCU)	Description and Operation	574-227-100TC	2
Cabinet (LAC)	Description and Operation	574-229-100TC	3
Cabinet (LAC)	Lubrication	574-229-701TC	3
Answer-Back Unit	Description and Operation	574-235-100TC	3
Answer-Back Unit	Installation	574-235-200TC	2
Answer-Back Unit	Lubrication	574-235-701TC	5
Answer-Back Unit	Disassembly and Reassembly	574-235-702TC	1

35 KEYBOARD SEND-RECEIVE (KSR) AND RECEIVE-ONLY (RO)

TELETYPEWRITER SETS

DESCRIPTION AND OPERATION

CONTENTS	PAGE	1. GENERAL
1. GENERAL	1	1.01 This section is reissued to combine information about the 35 Keyboard Send-Receive (KSR) and Receive-Only (RO) Sets under one section number. The section includes recent engineering changes and the addition of the wall mounted set. Since this reissue is of a general nature, marginal arrows have been omitted.
2. VARIATIONS	1	
3. COMPONENTS	2	
TYPING UNIT	2	
SEND-RECEIVE KEYBOARD AND RECEIVE-ONLY BASE	2	1.02 The 35 KSR Teletypewriter Sets are electromechanical apparatus that provide terminal facilities for exchanging page-printed messages over appropriate transmission facilities including telegraph lines, telephone networks, and radio channels. An operator sends the messages by typing them on a keyboard, and the originating set and those at distant stations print them on page-width copy paper or continuous business forms. The sets translate the messages to a serial start-stop (teletypewriter) code for transmission and convert the code to printed characters at the point of reception. They will operate at various speeds up to 100 words per minute.
MOTOR UNITS	2	
ELECTRICAL SERVICE UNIT	2	
ENCLOSURES	2	
4. VARIABLE FEATURES	7	
5. OPERATION	8	
STANDARD OPERATION (PRIVATE LINE)	8	1.03 The 35 RO Sets are similar to the KSR Sets, but have no keyboard sending facilities. They are used in applications that require only the reception of page-printed messages.
A. KSR and RO Sets Without Motor Control Relay	8	
B. KSR and RO Sets With Motor Control Relay	8	
C. Set Functions	8	1.04 The KSR and RO Sets can be used for recorded communication either cross office or cross country. With the proper modifications, they will function in dial or other switched-line networks. Utilizing the capabilities of a built-in switching device, the function box, the sets will provide local or remote control of external equipment or operations.
OPERATION OF SWITCHED NETWORK SERVICE SETS	9	
A. Station KSR and RO Sets	9	
B. Central Office Sets	10	
6. TECHNICAL DATA	10	2. VARIATIONS
SIGNAL REQUIREMENTS	10	2.01 The sets are available in several configurations to meet varying installation and operational requirements.
POWER REQUIREMENTS	11	
DIMENSIONS	11	

SECTION 574-201-100

2.02 With the proper modifications certain models will function in conjunction with tone-modulated telephone networks (Switched Network Service). These sets employ a call control unit in conjunction with a data set. The data set is not supplied with the equipment. When used, it is mounted on an apparatus rack in the pedestal of the cabinet or, in some installations external to the equipment. All of these components are discussed in detail in appropriate sections.

- (a) Floor Model Set - A floor-standing set with space in the pedestal for accessory equipment. The cabinet pan on this model is welded to the top of the pedestal (Figures 1, 2 and 3).
- (b) Table Model Set - Identical to the floor model set except that it has no stand (pedestal) and thus rests on any flat surface.
- (c) Wall Mounted Set - May be mounted on a wall surface to conserve floor space (Figure 4).

3. COMPONENTS

3.01 The component complement of a KSR Set may vary from one installation to another, depending upon the operational requirements. In general, a KSR Set consists of a typing unit, a keyboard base, motor unit, electrical service unit, and enclosure. A complete description of these components will be found in the appropriate section for a particular component.

3.02 The motor unit and typing unit are mounted on the base portion of the keyboard. The motor unit supplies rotary motion through a gear set to the typing unit which, in turn, supplies it to the keyboard. Gear sets may be interchanged to obtain various operating speeds up to 100 wpm. The keyboard and electrical service unit are mounted in a cabinet or enclosed by covers. The receive-only base replaces the keyboard in the Receive-Only Set.

TYPING UNIT

3.03 The typing unit contains the mechanism necessary for translating electrical input signals into printed, alpha-numeric characters or functional control operations. The unit may be equipped to accommodate either friction or sprocket feed paper (friction feed only on wall mounted models) in single or multi-copy form; either rolled or fan folded. It includes a function box that provides, non-printing

functions such as case shifting, carriage return and line feed and, in addition, switching facilities for remote controls, station selection, and other applications.

SEND-RECEIVE KEYBOARD AND RECEIVE-ONLY BASE

3.04 Both the send-receive keyboard and the receive only base provide mounting facilities for the typing unit, motor, driving gears, and various mechanisms required for control of the set. Unlike the receive-only base, the send-receive keyboard is equipped with mechanisms for generating and transmitting teletype-writer signals.

MOTOR UNITS

3.05 The motor units are mounted on top of the base, on the right rear corner, of table and floor models, and below the base, on the left rear side, of wall mounted models. The units provide mechanical motion for KSR and RO Sets and are of two basic types: ac synchronous and ac/dc series governed. The ac synchronous motor is used when the power source is regulated; the ac/dc series governed motor operates from either regulated or unregulated power. The latter is required where only unregulated power is available and special speeds are required.

ELECTRICAL SERVICE UNIT

3.06 The electrical service unit is mounted on the cabinet pan, directly behind the typing unit on floor and table models and on the lower mounting frame below the base on wall mounted models. The unit serves as the area of concentration for the wiring of KSR and RO Sets, and provides mounting facilities for various electrical assemblies and components. It may include such assemblies as a line shunt relay, rectifier, motor control mechanism, and selector magnet driver. The latter is a solid-state device required to amplify and shape incoming signals. The facilities provided by the unit will vary depending upon the number and complexity of functions performed by the sets.

ENCLOSURES (Figures 1 through 4)

3.07 The components of KSR and RO Sets may be housed in a number of different enclosures, including the floor model, the table model and the wall mounted enclosure. The table model is identical to the floor model except the cabinet pan rests on a flat surface instead of being welded to the top of the pedestal.

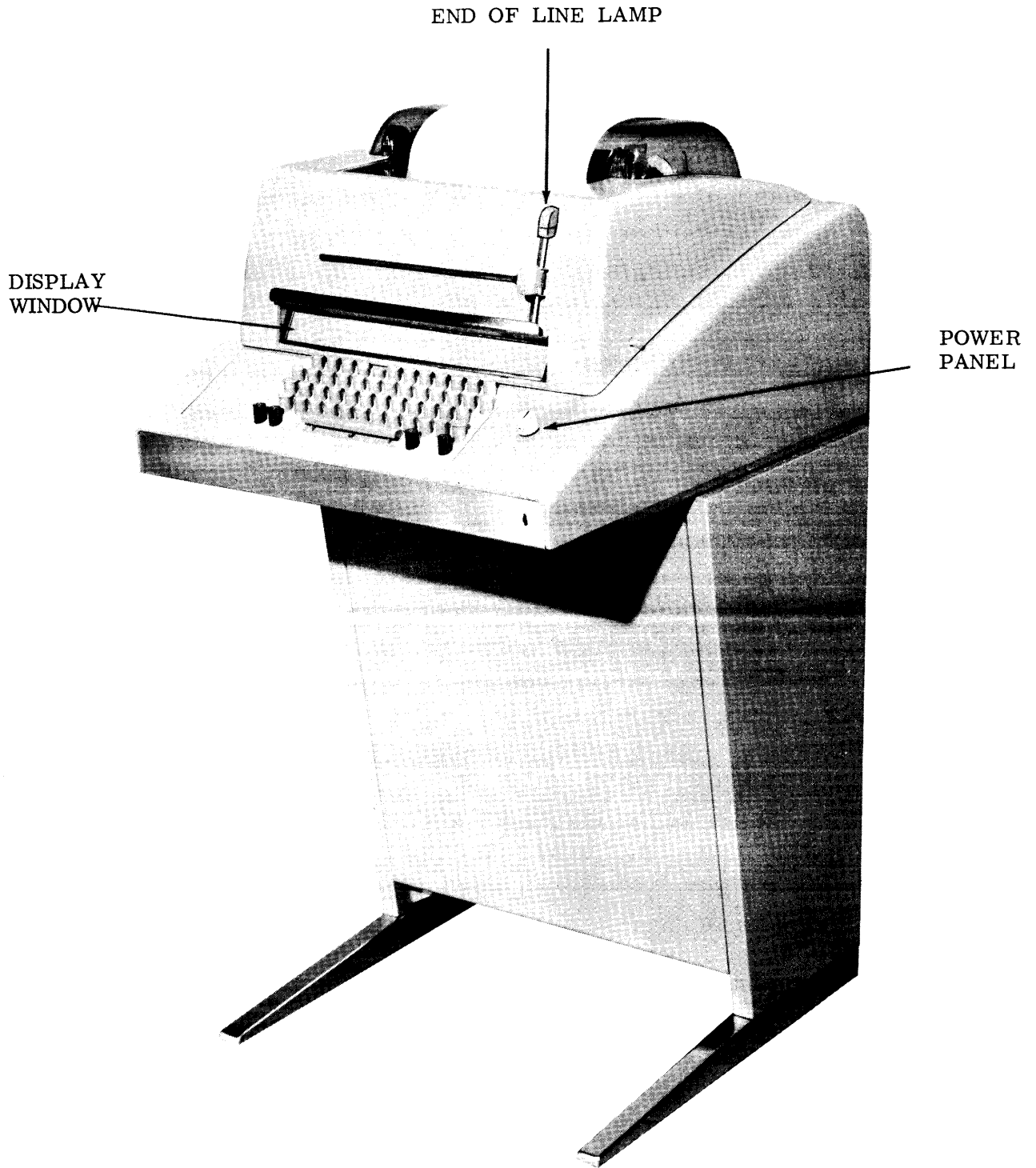

Figure 1 - 35 Keyboard Send-Receive (KSR) Teletypewriter Set
(Private Line Service)

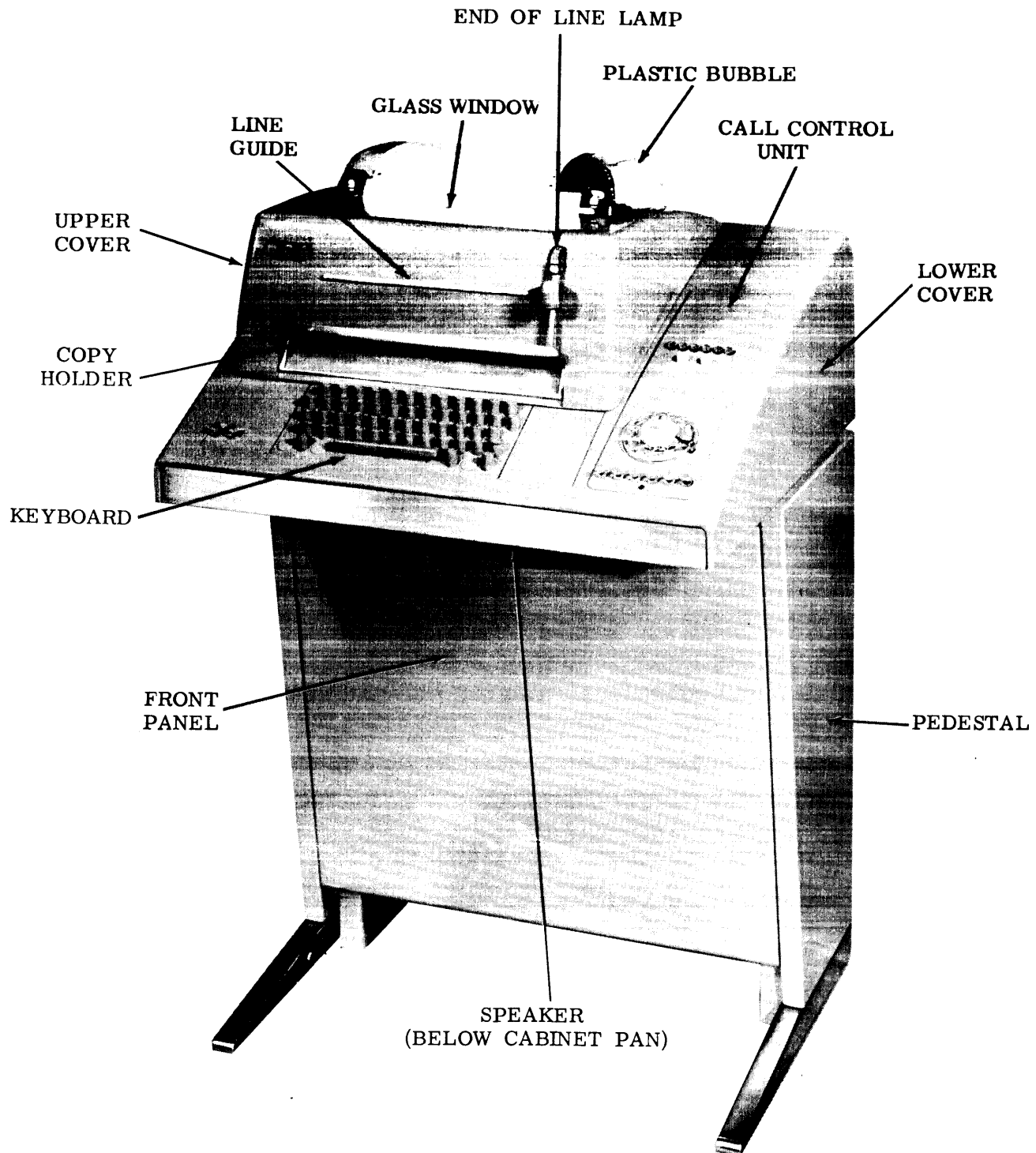

Figure 2 - 35 KSR Set With Call Control Unit
(Switched Network Service)

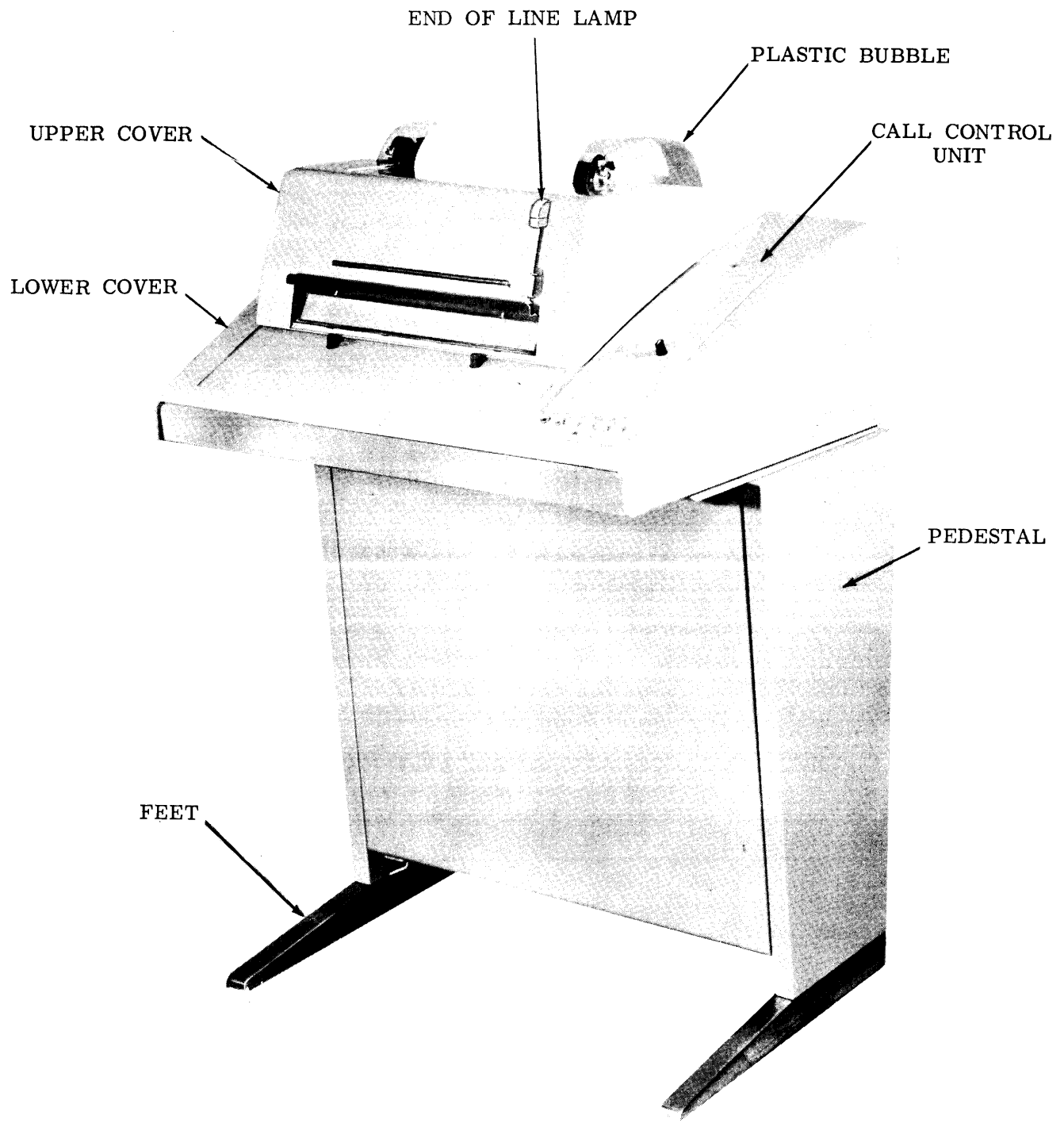

Figure 3 - 35 RO Set With Call Control Unit
(Switched Network Service)

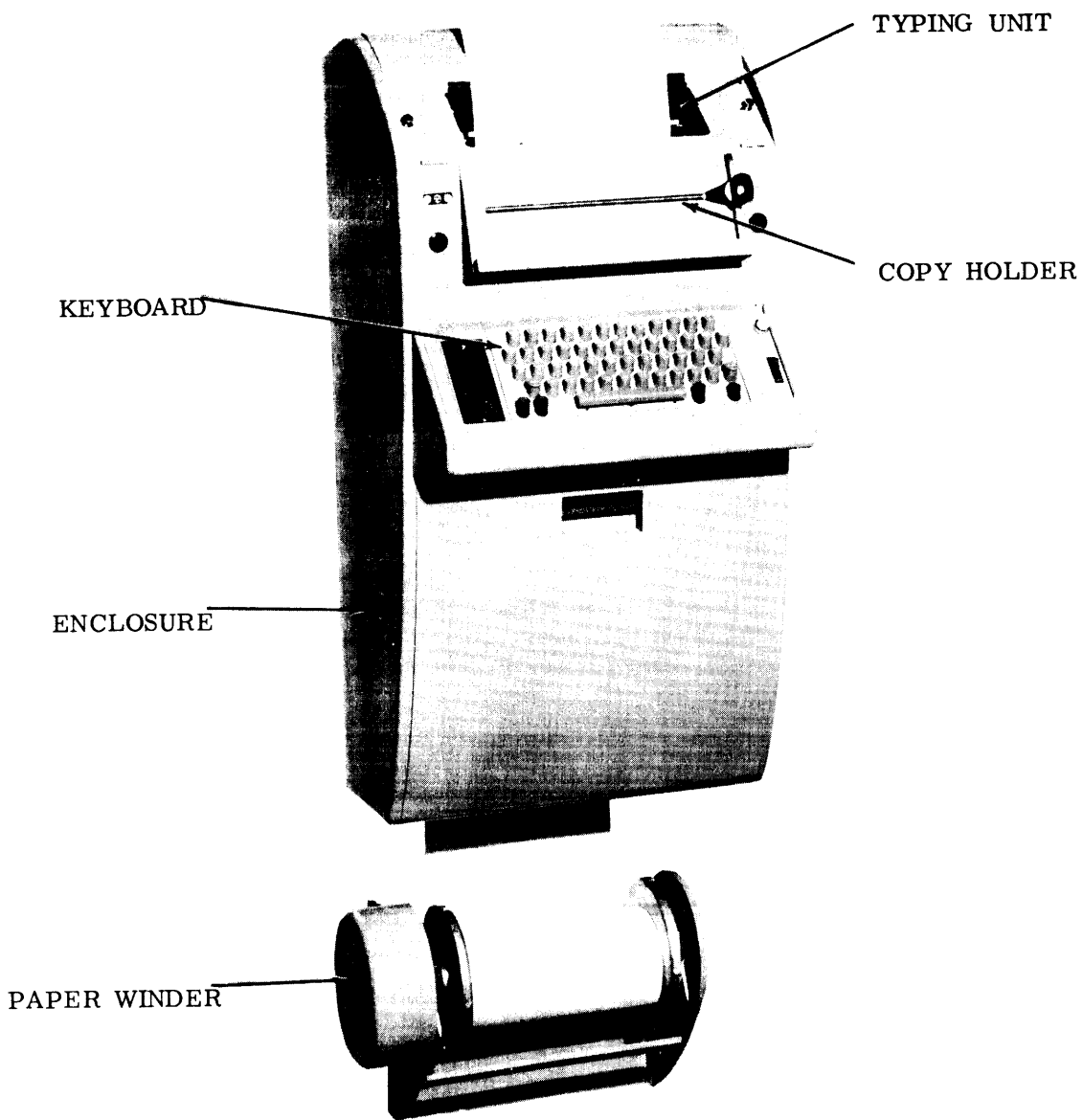

Figure 4 - Wall Mounted 35 KSR Set
(Private Line Service)

4. VARIABLE FEATURES

4.01 A wide variety of optional features are available with the equipment. These features, which provide special, nonprinting operations or control facilities, or serve as an aid in operation, are in most cases readily installed in the field. Some of the features are described briefly below:

- (a) Answer-Back Unit - With this feature, sets can automatically transmit their station identification character sequence, upon request of another station or by local control.
- (b) Call Control Unit - In conjunction with the data set, may provide facilities for

initiating, accepting, controlling, monitoring, and completing tone-modulated calls. It may include a speaker or hand held receiver, a selector magnet driver, a dialer, and various controls and indicators.

- (c) Motor Control Relay - Starts or stops the set's motor during active or idle transmission periods, or in response to other, predetermined signal-line or separate-line conditions.

- (d) Accessories - A number of accessories are available to facilitate paper and form handling, including low supply indicator alarms, special trays and shelves, and paper winders.

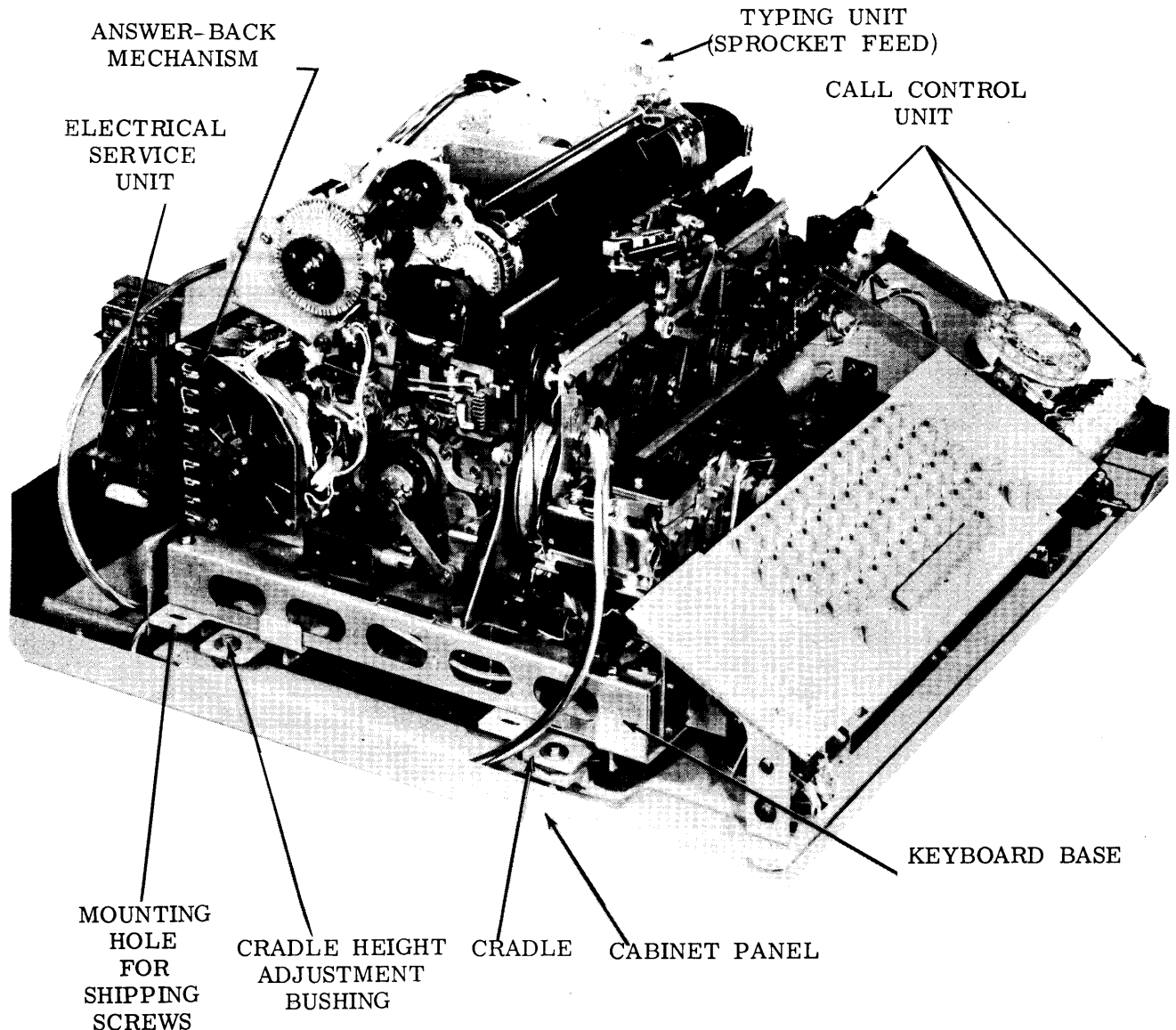

Figure 5 - 35 KSR Set With Cover Removed

5. OPERATION

5.01 The operation of 35 type sets may differ from set to set, depending upon the equipment complement and the service for which the set is designed. In general, two types of application will be discussed: sets that operate over standard lines and whose signal is transmitted as dc pulses, and sets that operate over telephone networks and employ a call control unit in conjunction with a data set to transmit by means of tone (or frequency) modulation.

STANDARD OPERATION (PRIVATE LINE)

A. KSR and RO Sets Without Motor Control Relay

5.02 In this type of operation, the set is energized by placing the power switch in the ON position. The keyboard signal generator (on KSR Sets) BREAK key and selector magnet driver (on KSR and RO Sets) are connected in a series loop with the external signal line and other sets on the line. In this way transmission between stations may proceed, provided the other station(s) are also turned on. It should be noted, however, that in the OFF position a station will be bypassed by the line shunt relay.

5.03 Each station can send only by operating the BREAK key which breaks the series loop with the external line. This stops data transmission from the distant station. In this way, any station on a loop is able to stop transmission over the line. The sending station must restore its ability to transmit by means of the BRK-RLS (break-release) key on the keyboard following a break.

5.04 Disconnecting, after a call has been completed, is accomplished by restoring the power switch to the OFF position. This de-energizes the line shunt relay so that the sending and receiving units of the set are shunted. The typing unit will run open for a short period, as a result of the line shunt relay de-energizing before the motor stops, and may print spurious characters. (An optional line-local relay, with its associated components, may be installed to prevent the printing of spurious characters when switching from line to off and to provide for off-line operation.)

B. KSR and RO Sets With Motor Control Relay

5.05 Where the sets in a system are equipped with electrical service units in which a motor control relay is included, the motor

control relay also is inserted in series with the signal line. In this arrangement the power switch remains in the ON position during operating hours.

5.06 This option enables a set to be externally controlled giving unattended operation. The sending station turns the receiving station on by sending a BREAK and turns it off after the data has been transmitted by sending the EOT (end of transmission) code.

C. Set Functions

5.07 Besides the usual printing function of the sets, certain other functions are available for controlling local and distant station equipment.

(a) KSR and RO Sets

- (1) Operation of the LOC CR (local carriage return) key releases the type box carriage allowing it to return to the left.
- (2) The LOC LF (local line feed) key, when depressed, causes the paper or form to feed out of the printer at an accelerated rate.

(b) KSR Sets Only

- (1) The REPT (repeat) key and any other key associated with a character depressed simultaneously results in repeated transmission of the character.
- (2) Operation of the SHIFT key simultaneously with any other key having a graphic symbol on the upper half of the keytop results in transmission of that code combination.
- (3) The BREAK key when operated causes the keyboard to be electrically shunted.
- (4) The BRK-RLS key allows the break switch to return to its unoperated position, unblinding the keyboard.
- (5) ALT MODE (alternate mode) key provides other functions (customer option) in station equipment. Pressing ALT MODE key before operating the desired function key will provide the nonprinting function.

(c) Local and distant station equipment functions are controlled by the function box of the typing unit transmitting. They are selected by depressing the CTRL (control) key and the desired function key on the keyboard simultaneously. The function occurs at both the sending and receiving stations.

- (1) TAB (horizontal tabulation), VT (vertical tabulation) and FORM (form out) are functions used only in sets containing sprocket feed printers.
- (2) The signal bell operates through function box make contacts.
- (3) EOT (end of transmission) is used in sets equipped with a motor control relay. The set is turned off when the code combination is transmitted by function box make contacts which cause the motor control stop magnet to energize.

OPERATION OF SWITCHED NETWORK SERVICE SETS

A. Station KSR and RO Sets

5.08 A more detailed explanation of operation of these sets will be found in the section describing the 35 call control unit.

5.09 A call is originated by depressing the ORIG pushbutton. This connects the station to the line, and lights the ORIG lamp. The lamp will remain on until the originate mode is terminated. A dial tone will be heard over the receiver in the set. Upon receipt of the dial tone, the operator may proceed to dial the desired telephone number. A speaker or hand held receiver will monitor the call progress. If the line is busy, depress the CLR (clear) pushbutton and try again. A rotary dialer may be temporarily connected into the telephone line for maintenance purposes by RO Sets. Dialing may be accomplished as follows, depending upon the equipment of a particular set:

- Rotary dial - used in the same manner as a telephone dial.
- Pulsing card dial - a card with the desired station's number punched in it is inserted into the card slot and pushed in. After the START bar is depressed the number is automatically dialed as the card advances out of the slot. Depress RELEASE bar to remove card.

- Touch-tone dial - depress the numbered pushbuttons in correct sequence. Each digit creates a tone which can be heard over the loudspeaker.
- Touch-tone card dial - operates same as pulsing card dial except the card is released by depressing the START bar again.

5.10 When a distant station is called, the ringer will momentarily sound and the set will automatically answer. The ANS (answer) lamp will light, and remain on for the duration of the call. If the set is in LCL (local) mode, the automatic answer feature is disabled, and the ANS pushbutton must be depressed in order to answer the call.

5.11 Other features of the station sets include the following:

- (a) Provision is made for insertion of an auxiliary receive-only typing reperforator (ROTR) selector magnet driver in series with the typing unit selector magnet driver. In this way, a perforated and typed record of message transaction can be prepared on tape. A detailed description of the ROTR Set will be found in another section.
- (b) The OUT OF SERVICE switch, when operated, renders the set unresponsive to incoming calls. The OUT OF SERVICE lamp is lit, the ringer is disconnected, and the set appears as a don't answer (or busy, if the set has been so modified).
- (c) Paper handling controls of the sets provide low paper alarm circuits, a paper out disconnect feature, and a form control and tabulating system.
 - (1) Low paper alarm is given by a buzzer. A BUZ-RLS (buzzer release) key silences the buzzer and lights the BUZ-RLS lamp. The paper supply must be replenished and the key released to return the set to normal.
 - (2) The automatic answer circuit is disabled by operation of the low paper switch or when the tape supply runs low in the auxiliary ROTR Set. However, an operator can override the disabled automatic answer circuit by manually answering.

- (3) The paper out disconnect feature in sprocket feed typing units performs the same function as the CLR key. It is used in conjunction with low paper contacts, so that no calls will be accepted following the disconnect until paper is replaced in the set.
 - (4) The form feed operation in a sprocket feed typing unit is initiated from the function box following recognition of the FORM code combination. It is also tripped whenever the data set disconnects, unless the paper is already between forms.
 - (5) The sprocket feed typing unit is also equipped with horizontal and vertical tabulation mechanisms which are controlled by code recognition in the function box.
- (d) The WRU (who are you) key, when held down simultaneously with the CTRL (control) key, allows either station to operate the distant stations answer-back.
 - (e) The HERE IS key allows a station to send its own answer-back to the distant stations.
 - (f) The BREAK pushbutton is used by sending KSR stations to immediately stop transmission without losing the connection. The break will blind both sending and receiving keyboards so that no transmission can occur. The condition is indicated by the lighting of the break lamp in the BRK-RLS pushbutton. Each station must restore its ability to transmit by depressing its BRK-RLS pushbutton. The BREAK pushbutton should not be operated when the set is in LCL mode. The BREAK pushbutton is used by receiving RO stations to control an automatic test line.
 - (g) The REST lamp on KSR Sets lights to warn the typist to slow down when communicating with a slower speed station. If the conversion apparatus is overloaded, a break signal will be generated. The break is distinguished by the fact that both the restrain and break lamps are lighted. To restore transmission, the BRK-RLS pushbutton must be operated.
 - (h) To use the KSR Set for practice typing and other off-line functions, depress the LCL (local) pushbutton. This will turn the motor unit on and disable the automatic

answer-back mechanism. The ringer will signal any incoming calls. These can be answered by depressing the ANS pushbutton.

Note: If the TEST key is operated by KSR or RO Sets while connected to a test center, the message sent by the test center will be turned around and sent back for analysis.

B. Central Office Sets

5.12 These sets are operated in a manner similar to station sets, but have no call control facilities for originating calls. The sets are used for monitoring purposes, and for supervisory direction applications.

5.13 Normally, these sets are operated remotely by energizing their motor control relays, which closes the circuit to the motor units. When the motor starts, the typing unit will respond to the incoming signals and convert them into typed copy.

6. TECHNICAL DATA

SIGNAL REQUIREMENTS

6.01 Data is received or transmitted using the American Standard Code for Information Interchange (ASCII). This code is an eleven unit, equal bit code. The start bit, always transmitted as spacing, eight intelligence bits, and a stop pulse two bits in length and always transmitted as marking for synchronization purposes, make up the code. Intelligence bits one through seven may be either marking or spacing depending upon the character or function to be transmitted. The eighth bit is always marking unless the sets are equipped to provide an even parity output. If even parity is provided, the eighth bit may be either marking or spacing in order to always supply an even number of marking pulses for each code transmitted. (This is a feature of sets that provide error detection.) At an operating speed of 100 words per minute, each bit is 9.09 milliseconds in length. See the applicable section for a detailed description of the code.

6.02 The dc signal received over the incoming line is an on-off (mark-space) current type which varies from either 0.060 ampere or 0.020 ampere (marking) to zero ampere (spacing), depending upon the equipment. In tone modulation circuits a data set provides the 0.020

ampere dc signal by demodulating ac tones that have been transmitted over telephone networks.

6.03 Signals from the incoming line or from the data set are amplified to 0.500 ampere marking and zero ampere spacing pulses by the selector magnet driver.

POWER REQUIREMENTS

6.04 The motor units that provide electro-mechanical rotating motion for operating

the various 35 teletypewriter sets are of two basic types: synchronous and series (governed).

(a) Sets with synchronous motor units - 115 v ac, $\pm 10\%$, 60 $\pm 75\%$ cycles, single phase.

(b) Sets with governed motor units -

(1) 115 v ac $\pm 10\%$, 50-60 cycles, single phase.

(2) 115 v dc $\pm 10\%$, with external resistance.

DIMENSIONS (INCHES)

Set	Height	Width	Depth
Floor Model (With Call Control Unit)			
KSR	38-1/2	24	24
RO	38-1/2	24	24
Floor Model (Without Call Control Unit)			
KSR	38-1/2	20	24
RO	38-1/2	20	24
Table Model			
KSR	13-1/2	20	24
RO	13-1/2	20	24
Wall Mounted Model			
KSR	31-3/4	16-1/2	14-1/4
RO	31-3/4	16-1/2	10-1/2

35 KEYBOARD SEND-RECEIVE (KSR) AND RECEIVE-ONLY (RO)

TELETYPEWRITER SETS

INSTALLATION

CONTENTS	PAGE
1. GENERAL	1
2. INSTALLATION	1
CABINET	1
FRICTION FEED TYPING UNIT . . .	1
SPROCKET FEED TYPING UNIT . .	2

1. GENERAL

1.01 The 35 Receive Only (RO) sets and the Send Receive (KSR) sets are each packed in two packages; one contains the cabinet and the other the typing unit. For sprocket feed sets, the modification kit for equipping the cabinet with paper supply and accumulating shelf is edited separately. Mounting hardware and other loose parts may be in a cloth bag and tied to the unit or wrapped separately and packed in the same carton.

2. INSTALLATION

CABINET

- 2.01 Place packing carton so that the top side of carton is up.
- 2.02 Clip the bottom metal strap.
- 2.03 Lift the corrugated tube and top cap of the packing carton up.
- 2.04 Remove and set aside the lower compartment panel and offset copyholder which are packed separately within the carton.
- 2.05 Roll unit over on a soft surface to prevent scratching. Remove the bolts which fasten the feet or pan to the pallet and remove the pallet.
- 2.06 Set the unit upright. Remove all tape and wrapping from the set and components.

2.07 Raise upper cover on cabinet.

2.08 Remove the four shipping screws, washers, and spacers which fasten the base mounting brackets rigidly to the cradle for shipment.

TYPING UNIT

2.09 Unpack the typing unit.

INSTALLATION (FRICTION FEED)

NOTE: The typing unit can be installed with the upper cover open. If it becomes necessary to gain access to the rear of the typing unit or base, the lower cover may be removed. Remove call control unit bezel before attempting to remove lower cover. The cover weighs approximately 30 pounds. To remove the lower cover, unlatch the lower cover latch inside the cover, close the upper cover to latched position. Loosen the hinge lock bracket mounting screws and slide the bracket away from the hinge. Support the cover from the rear. Raise the lower cover at front. Remove the acorn type nut from the upper stop arm stud and disengage the arm from the cover. Move the cover sideways to separate it from the pins on the hinge.

2.10 Set typing unit on base in cabinet.

2.11 Refer to appropriate section on 35 Keyboard and Base for Keyboard Send Receive Only Sets to make adjustments between Typing Unit and Base, or between Base and Answer Back.

2.12 Secure Typing Unit to base with the four mounting screws furnished with the base.

2.13 Refer to appropriate section on 35 cabinet for Keyboard Send Receive and Receive Only Sets to make adjustments for Bubble Position Front and Rear (Final), Upper Cover Latch, Paper Guide, and Window (Final).

2.14 Install paper roll.

INSTALLATION (SPROCKET FEED - See Note above on removal of lower cover.)

2.15 Install the form accumulating shelf to the back of the cabinet according to instructions in the installation specification furnished in the carton with the shelf.

2.16 Install the sprocket feed rear paper guide as outlined in the specification furnished with the paper guide. Disregard references to terminal blocks in the cabinet.

2.17 Substitute the form guide, furnished with the sprocket feed typing unit, for the paper guide mounted to the bubble on the cabinet.

2.18 Set typing unit on base in cabinet.

2.19 Refer to appropriate section on 35 Keyboard and Base for Send Receive and Receive Only Sets to make adjustments between Typing Unit and Base, or between Base and Answer Back.

2.20 Secure the typing unit to base with the four mounting screws furnished with the base.

2.21 Refer to appropriate section on 35 cabinet for Keyboard Send Receive and Receive Only Sets to make adjustments for Bubble Position Front and Rear (Final), Upper Cover Latch, Paper Guide, and Window (Final).

2.22 Refer to appropriate section on 35 cabinet for Keyboard Send Receive and Receive Only Sets to make adjustments for Form Guides.

2.23 Install sprocket feed paper. Make sure that the paper out and low paper levers rest on top of the paper.

2.24 Make the final window adjustment for sprocket feed sets.

2.25 Install the offset copyholder previously removed.

2.26 Install the lower compartment panel by sliding it into place over pivots on each side of the pedestal and fastening it at the top by means of the push button fastener.

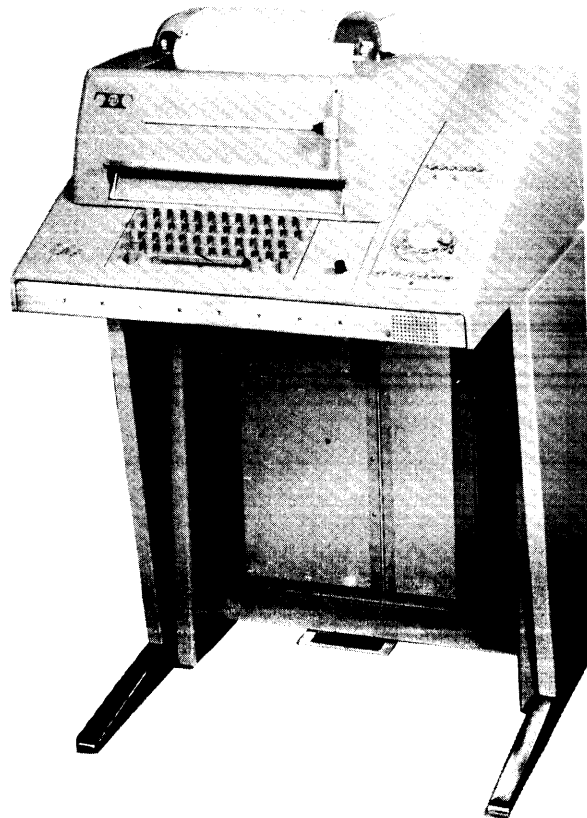

Figure 1 - 35 Send-Receive Page Printer Set

35 TYPING UNIT

GENERAL DESCRIPTION AND PRINCIPLES OF OPERATION

CONTENTS	PAGE	CONTENTS	PAGE
1. GENERAL DESCRIPTION	1	A. General	34
PHYSICAL DESCRIPTION	5	B. Carriage Return Function	37
TECHNICAL DATA	6	C. Line Feed Function	38
A. Approximate Dimensions	6	D. Stunt Box Contacts	43
B. Signal	6	3. FRICTION FEED TYPING UNIT	44
C. Electrical Requirements	6	GENERAL DESCRIPTION	44
2. PRINCIPLES OF OPERATION	7	PRINCIPLES OF OPERATION	44
SIGNALING CODE	9	4. SPROCKET FEED TYPING UNIT	45
GENERAL OUTLINE OF OPERATION	10	GENERAL DESCRIPTION	45
MAIN SHAFT	13	PRINCIPLES OF OPERATION	45
A. General	13	5. VARIABLE FEATURES	46
B. One Stop Clutches	14	PAPER OUT CONTACTS	46
C. Three Stop Clutches	15	FORM OUT AND PAPER JAM CONTACTS	46
D. Six Stop Clutches	15	HORIZONTAL TABULATION	46
SELECTION	15	FORM OUT AND VERTICAL TABULATION	51
ORIENTATION	17	1. GENERAL DESCRIPTION	
PRINTING MECHANISM	18	1.01 This section has been revised to include recent engineering changes and to add late 35 type equipment.	
A. Code Bar Mechanism	18	1.02 In the descriptions and principles of operation used in this section, a basic printer mechanism equally applicable to both units covered is presumed. Unless specifically limited to a certain unit, all descriptions and	
B. Type Box and Type Box Carriage	20		
C. Print Hammer and Printing Carriage	27		
D. Print Suppression	29		
SPACING MECHANISM	30		
A. General	30		
B. Spacing Function	30		
C. Spacing Suppression	30		
D. Margin Indicator	33		
RIBBON FEED MECHANISM	33		
FUNCTIONS	34		

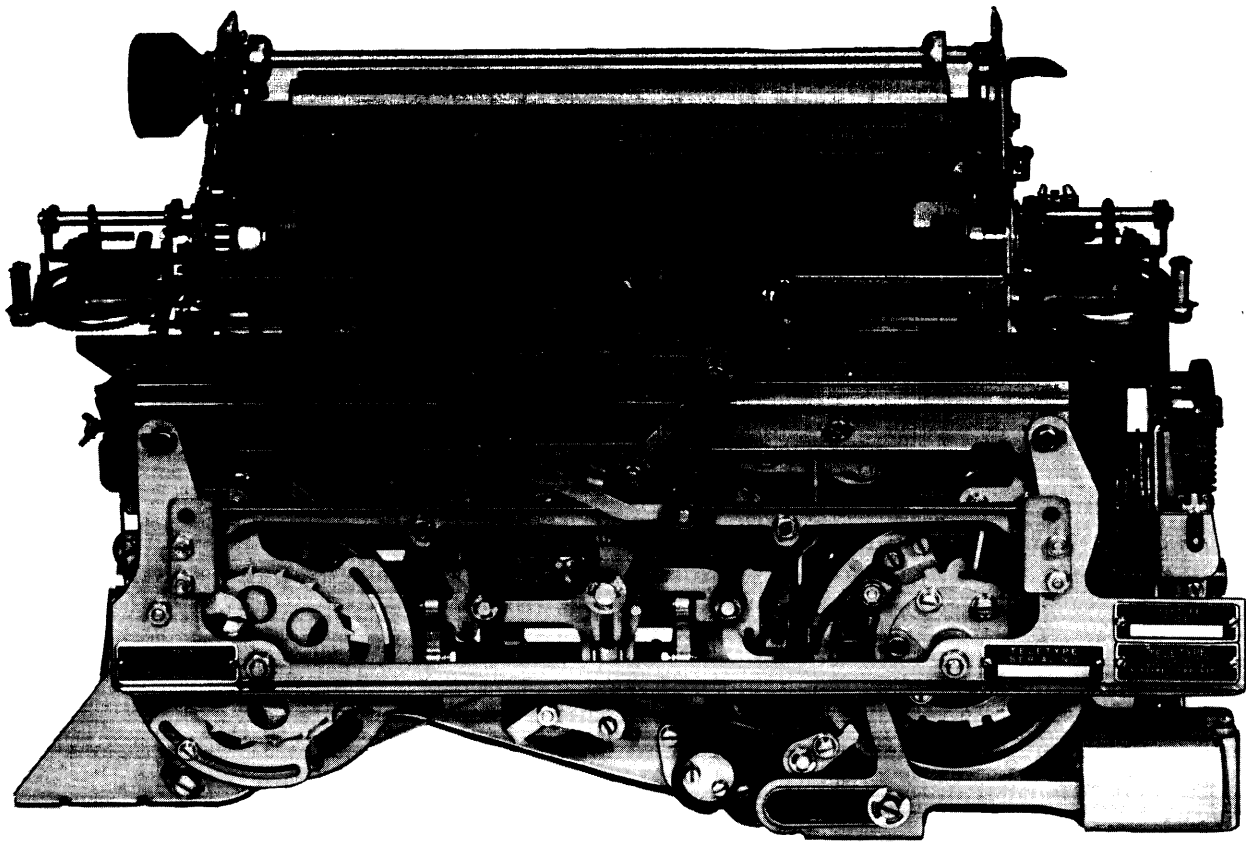

Figure 1 - Friction Feed Typing Unit

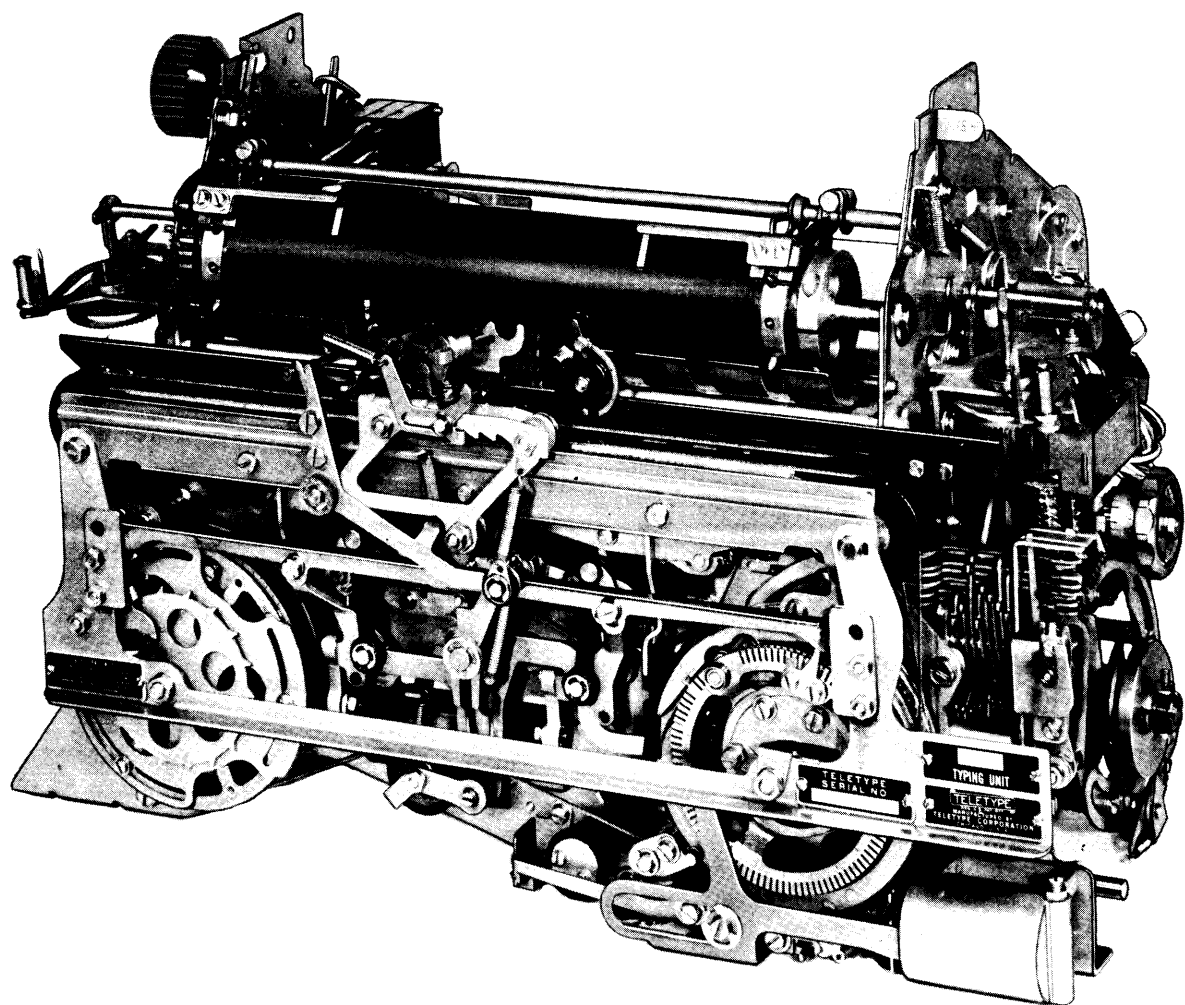

Figure 2 - Sprocket Feed Typing Unit

illustrations may be considered as pertaining to both the friction feed typing unit and the sprocket feed typing unit. Variable or optional features of either or both printers are considered separately after discussion of the basic printer.

1.03 Unless stated to the contrary, references in the text to left or right indicate the operator's right or left, facing the front of the unit, the selector mechanism at the right, and the type box at the front. In illustrations, unless specifically labeled otherwise, it is assumed that the equipment is being viewed from the front. Pivot points are shown in the drawings by circles or ellipses which are solid black to indicate fixed pivot points and crosshatched to indicate floating points.

1.04 With the main shaft under power (associated equipment main power supply on), the typing unit is described as running closed when a steady current (marking) condition is maintained in the signal line and no signal intelligence is received. It is described as running open when a no current (spacing) condition is maintained through an interruption in signal line current.

1.05 The typing unit is an electro-mechanical device to translate eight level signal code combinations sequentially received in an 11.0 unit transmission pattern into mechanical actions which print the message and perform functions incidental thereto. The friction feed typing unit (Fig. 1) prints the message upon single or multiple copy paper from a five inch diameter roll. The sprocket feed typing unit (Fig. 2) prints the message on flat folded form feed paper with marginal perforations spaced to fit the sprocket teeth on the typing unit platen.

1.06 Motive power for operation of the typing unit is received through the intermediate gear mechanism of the base or keyboard base on which the unit is mounted. Power is applied to the driven gear, centrally located on the main shaft at the rear of the typing unit. The main shaft rotates at a constant speed to operate the equipment at speeds of 60, 75 or 100 words per minute, depending upon external gear ratios.

1.07 Six all-steel internal expansion clutches convert the rotary motion of the main shaft to the linear mechanical requirements for operation of the printer. The clutches rotate with the main shaft when engaged and do not rotate when disengaged (latched). From left

to right in their installed position on the main shaft, the clutches control the type box, line feed, spacing, function, code bar and selecting mechanisms, respectively.

1.08 The line feed and spacing clutches on the friction feed typing unit are each provided with three sets of stop lugs (six sets on the sprocket feed unit), permitting operation of associated mechanisms through one-third (or one-sixth) of a revolution of the main shaft each time they are engaged.

1.09 Clutch engagement usually is initiated by an incoming electrical signal code which is sensed by the selecting mechanism. The selector, code bar and function clutches operate on each incoming signal. The spacing and printing clutches normally operate on each incoming signal, but these operations may be suppressed if the code combination received represents a function for which there is no graphic (printed) equivalent. The line feed clutch normally does not operate except in response to a code for the line feed function. Both the line feed and spacing clutches, however, may be operated independently of all other mechanisms by a direct mechanical linkage to the associated keyboard or base for local line feeding or spacing or carriage return functions.

1.10 The selecting mechanism, in addition to the clutch, includes a two-coil magnet in series with the external signal line. The magnets are operated on a 0.500 ampere circuit from a selector magnet driver in the electrical service unit. A range finder is used to refine the mechanical orientation of the selector to the signaling code.

1.11 The code bar mechanism, when positioned by the selecting mechanism to correspond to the input code intelligence, sets up mechanical requirements for type box positioning, printing and stunt box operation.

1.12 The type box is capable of vertical and horizontal positioning in response to the permutations set up by the code bar mechanism. When positioned to correspond to the input code intelligence, the type box presents a single type pallet with the embossed graphic equivalent of the selected code for printing. Printing is accomplished when this pallet is struck by the print hammer to press an inked ribbon against the paper, which is supported by the typing unit platen.

1.13 The spacing mechanism moves the type box and printing mechanism one character to the right each time a graphic character is received and imprinted. A suppression mechanism prevents spacing on receipt of certain non-typing functions. On sprocket feed typing units, the spacing mechanism permits horizontal tabulation to the right across the page to predetermined stop positions.

1.14 The line feed mechanism permits single or double line advance of paper in the platen mechanism when the code combination for this function is received. The function may also be initiated locally through mechanical linkage with the base or keyboard base. On sprocket feed typing units, the line feed mechanism is adapted to vertical tabulation and to rapid form feed out.

1.15 The stunt box operates in response to permutations equivalent to non-typing function code combinations set up in the code bar mechanism. The stunt box mechanisms initiate either mechanical or electrical switching sequences for operating the associated function or for the control of external equipment.

PHYSICAL DESCRIPTION (Fig. 3 and 4)

1.16 The mechanisms and sub-assemblies of which the typing unit is constructed are mounted upon or suspended between the left and the right side plate assemblies and the front plate assembly. The selecting mechanism is mounted on the right side plate. The main shaft, code bar mechanism, platen and paper feed mechanism, type box and stunt box are suspended between the side plates. The type box positioning and printing mechanisms are located in the front plate assembly.

1.17 The selecting mechanism is mounted around the right end of the main shaft. It includes a two-coil magnet, a selector cam-clutch and a range finder. By means of the range finder, the selecting mechanism can be adjusted in relation to the signal code.

1.18 The code bar mechanism consists of the code bar positioning mechanism, which is operated through the selector cam clutch, the code bars, which operate the type box positioning and stunt box selection mechanisms, and the printing suppression mechanism. The suppression mechanism is located at the left end of the code bars.

1.19 The stunt box mechanism, when one of its operating components is selected by the code bar mechanism, is operated by a function bail and a stripper bail. Completion of the selected function is accomplished either by electrical switching, through various switches mountable on top of the stunt box, or by direct mechanical linkage to printer mechanisms, such as the carriage return and line feed functions.

1.20 The line feed mechanism is operated through the line feed clutch and levers and gears mounted on the left side plate. On sprocket feed typing units so equipped, the vertical tabulation mechanism is also mounted on the left side plate, as is a solenoid operated form feed mechanism. Both mechanisms operate through the line feed clutch.

1.21 The printing mechanism located in the front plate assembly is operated by a shaft suspended between the side plates. The mechanism includes horizontal positioning mechanisms operated by the code bars, spacing mechanisms and carriage return, and the print hammer mechanism. When mechanically conditioned by the code bar mechanism, the printing mechanism prints the selected character and spaces to the next printing area on the paper, or spaces without printing on units so equipped, tabulates horizontally, or returns the type box to the left hand printing margin.

1.22 The type box is positioned vertically by a code bar operated linkage in the right side frame and horizontally by the front plate mechanism. The removable type box, with individually removable pallets for each graphic character representation required in the signal code, moves from left to right in front of the platen. As each code combination is set up in the code bar mechanism, the vertical and horizontal positioning mechanisms and the shift mechanism locate the selected graphic character in position for printing.

1.23 A ribbon feed mechanism passes an inked fabric ribbon between the type box and the paper. The ribbon mechanism advances the ribbon horizontally when each character has been printed. The mechanism automatically reverses the direction of ribbon feed when one of the two ribbon spools has been emptied.

1.24 The platen and paper feed mechanisms are located at the top of the printer, between the two side plates. A manual paper or form feed out knob is located at the top of the left side plate. Paper is fed from a supply

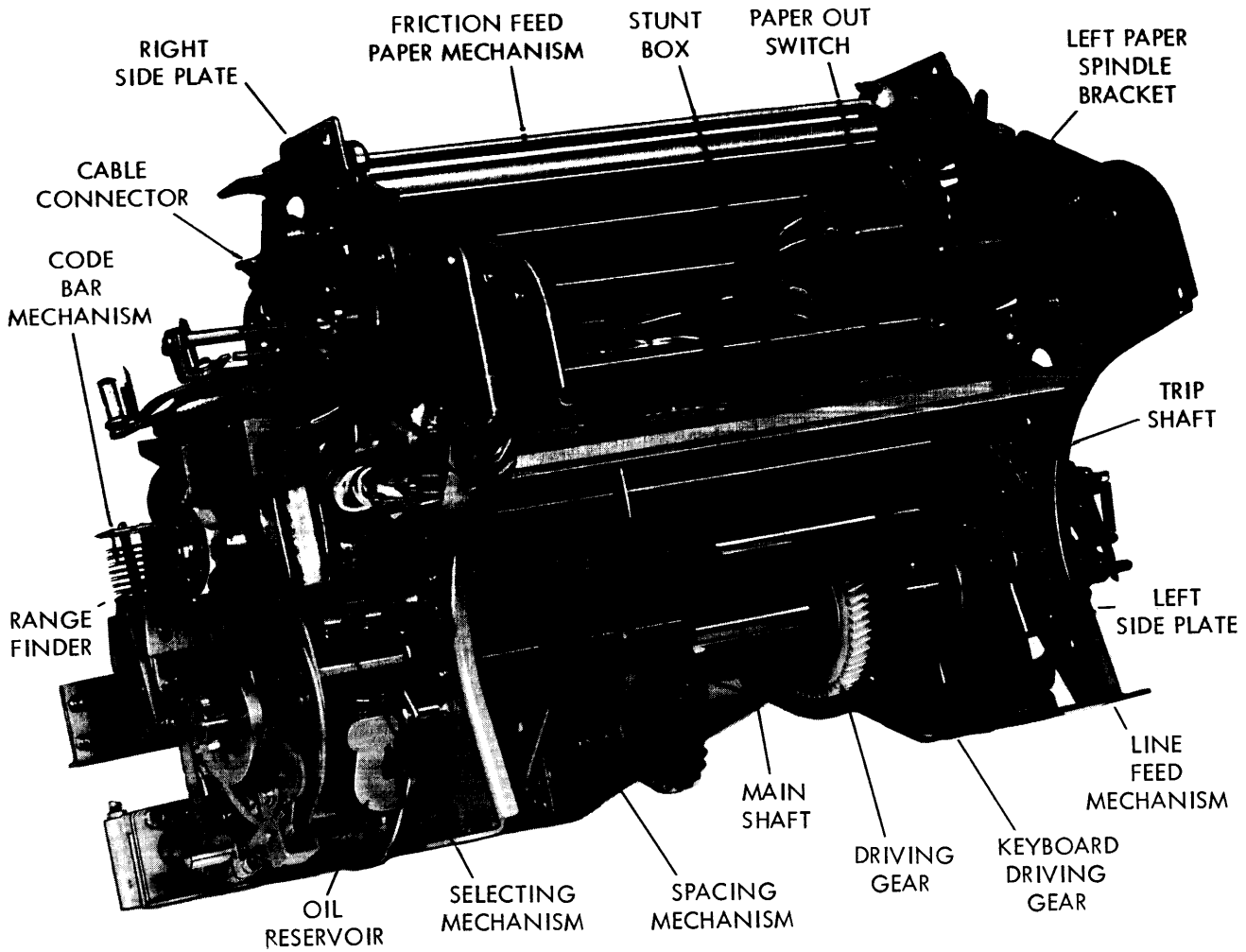

Figure 3 - 35 Typing Unit (Friction Feed) (Right Rear View)

at the rear of the printer either by friction feed or on sprockets located on the ends of the platen.

1.25 Mechanical off-line control of line feed and carriage return functions from the local base or keyboard base is accomplished through linkage of the base and the function trip mechanisms involved. A solenoid operated form feed mechanism at the rear of the left side plate is peculiar to sprocket feed typing units so equipped.

TECHNICAL DATA

A. Approximate Dimensions

Width 15-1/2 inches
 Depth 10-1/2 inches

Height 9-3/4 inches
 Weight
 Friction Feed 19 pounds
 Sprocket Feed 22 pounds

B. Signal

Code Sequential, 11-unit,
 Start-Stop
 Current 0.500 amperes

C. Electrical Requirements

1.26 All electrical requirements for operation of the 35 typing unit are supplied through associated equipment, such as a base, keyboard base or electrical service unit. Refer to the

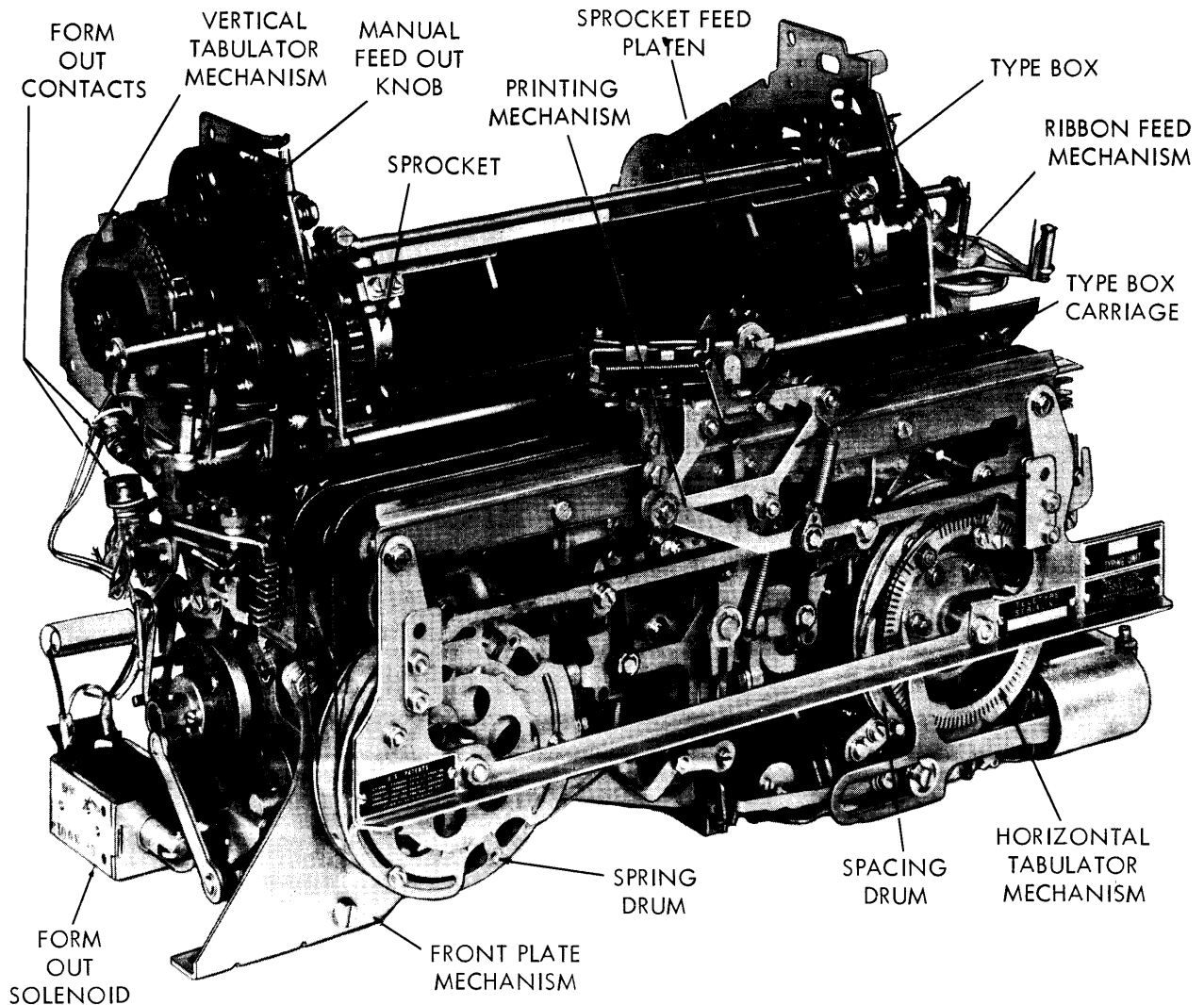

Figure 4 - 35 Typing Unit (Sprocket Feed) (Left Front View)

applicable section for a detailed discussion of the signal and power input. All electrical connections to the typing unit are made through a cable connector mounted just above the selecting mechanism on the right side plate.

1.27 A 500 milliamper DC signal current is required to operate the selector magnets.

1.28 Electrical contacts for certain variable features, such as the paper out alarm and the form out alarm, horizontal tabulator, vertical tabulator and form out and the local form out solenoid require 110 v ac circuitry. The circuits to stunt box switching contacts are

generally 110 v ac, but the specific nature of these circuits depends upon the external controls operated by the contacts.

2. PRINCIPLES OF OPERATION

2.01 The basic function of the 35 typing unit is to record in page printed form information received from a signal line in the form of a signaling code combination which represents characters or functions. The typing unit translates these electrical code combinations into mechanical motions which imprint the message or initiate the indicated function, such as line

feed, carriage return, or signal bell. Printing is accomplished through an inked ribbon upon paper rolled around a horizontally stationary platen while the type and printing mechanism move from left to right across the page. All operations of the typing unit are performed automatically in response to input signal code combinations. A few local off-line functions such as line feed, carriage return or form out may be initiated independently of the signal line from the local keyboard or base mechanism.

2.02 Character representations, or graphics, are the alphabetic, numeral or symbol

intelligence equivalent of the input code combinations. Function representations are the coded equivalent of non-typing operations auxiliary to reception of the graphics, such as line feed, carriage return, or signal bell.

2.03 The speed of operation of the equipment is usually given in operations per minute. Speed in words per minute is roughly one-sixth of the operations per minute. The typing unit is designed to operate at 60, 75 or 100 words per minute, depending on the gear ratio used on associated equipment.

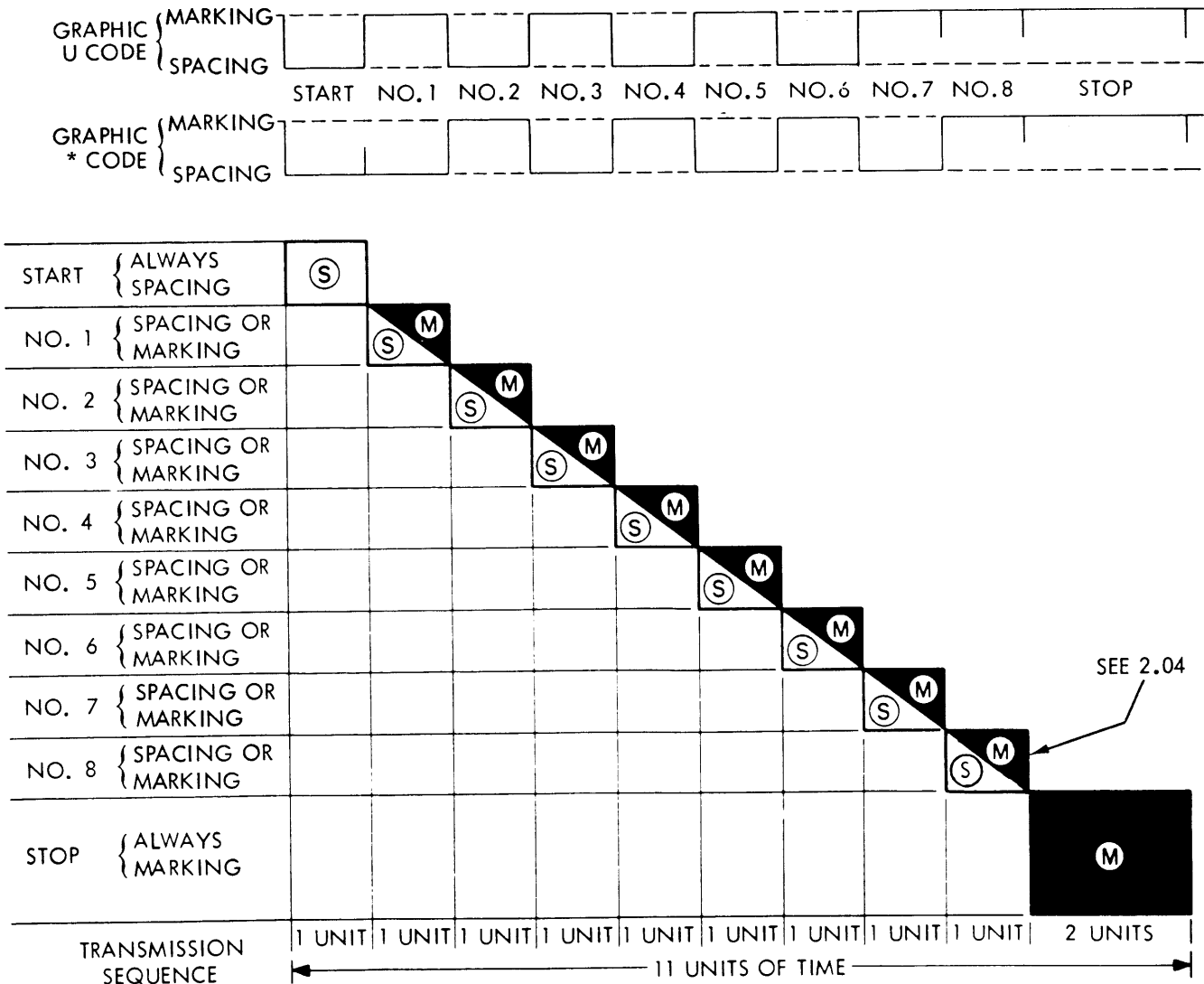

Figure 5 - 11.0 Unit Transmission Pattern Signaling Code

2.06 The total number of permutations of an eight level, eleven unit code (with the eighth level always marking) is two to the seventh power, or 128. Specific character and function representations may vary with equipment. The characters (graphics) and functions commonly represented on associated keyboards are illustrated, with their signal code equivalent, in Fig. 6. Function representations which are blank are unassigned in the current application, but the equipment can be readily adapted to their recognition and execution. For a more complete discussion of the signaling code, refer to the applicable section.

GENERAL OUTLINE OF OPERATION (Fig. 7)

2.07 The relationship of the operating mechanisms of the 35 typing unit are illustrated in the block diagram (Fig. 7). Rotary motion from the intermediate gear mechanism of an associated base or keyboard base is applied to the main shaft, which turns constantly as long as the associated unit is under power. A 0.500 ampere signal to the selector magnets initiates operating sequences. The application of 115 v ac circuits to the stunt box and to various switches and controls is dependent upon external circuitry and associated equipment.

2.08 The signaling code combinations are applied to the selecting mechanism through pins 1 and 2 of the cable connector located just above the selector magnets. The start pulse (spacing) of each code combination permits the start lever to fall to the rear behind the magnet armature and rotate to trip the selector cam clutch. The range finder mechanism permits adjustment of the angular relationship of the trip-off point to the optimum quality incoming line signal.

2.09 The selector cam clutch is driven by the main shaft, like the other clutches. When it is engaged by the main shaft, however, it effectively converts the incoming electrical signal into mechanical marking or spacing operations which are equivalent to corresponding bits in the signal code.

2.10 The code bar clutch initiates mechanical actions which position the code bars in patterns determined by the selecting mechanism (marking-left, spacing-right), and condition the printer for type box positioning, function selection and printing. A cam operated by the code

bar clutch operates the function clutch and type box clutch trip mechanisms.

2.11 The function clutch controls the function bail and the stripper bail. The function bail permits transfer of intelligence from the code bars to the function mechanism and, upon receipt of a function code, operates the function linkage or switch or contact corresponding to the input signal code. The stripper bail resets selected function mechanisms. When the input signal calls for carriage return function, direct mechanical linkage between the stunt box and the spacing mechanism initiates this function. When the input signal calls for line feed, the function mechanism trips the line feed mechanism, engaging the line feed clutch.

2.12 The line feed clutch operates mechanical linkages which advance the paper one or two line spaces by rotating the platen. On sprocket feed typing units so equipped, the vertical tabulation mechanism and form out mechanism also operate the line feed clutch trip mechanism.

2.13 The code bar mechanism (Par. 2.10) and the code bar clutch operate in combination either to trip or to block the tripping of the type box clutch. In the latter case, all printing mechanisms are idle as print suppression permits performance of a function without interference with the page printed message. When the type box clutch is tripped, it initiates mechanisms involved in vertical positioning of the type box, shift, horizontal type box positioning, ribbon feed and printing. The main rocker bail provides power from the type box clutch (and main shaft), and the code bars determine the specific application of that power required for each input signal code combination representing a graphic. A cam plate on the main rocker bail trips the spacing clutch stop mechanism to engage the spacing clutch, except when spacing is suppressed.

2.14 The spacing clutch, when tripped by the cam plate on the printing mechanism main rocker bail, advances the type box and printing hammer one character space to the right across the paper. Spacing suppression may be initiated by the function mechanism, to permit execution of a non-typing function without interference with the page printed message, by the carriage return mechanism or by the printing mechanism when the type box reaches the end of a printed line. A horizontal tabulation mechanism, on units so equipped, operates through the spacing clutch.

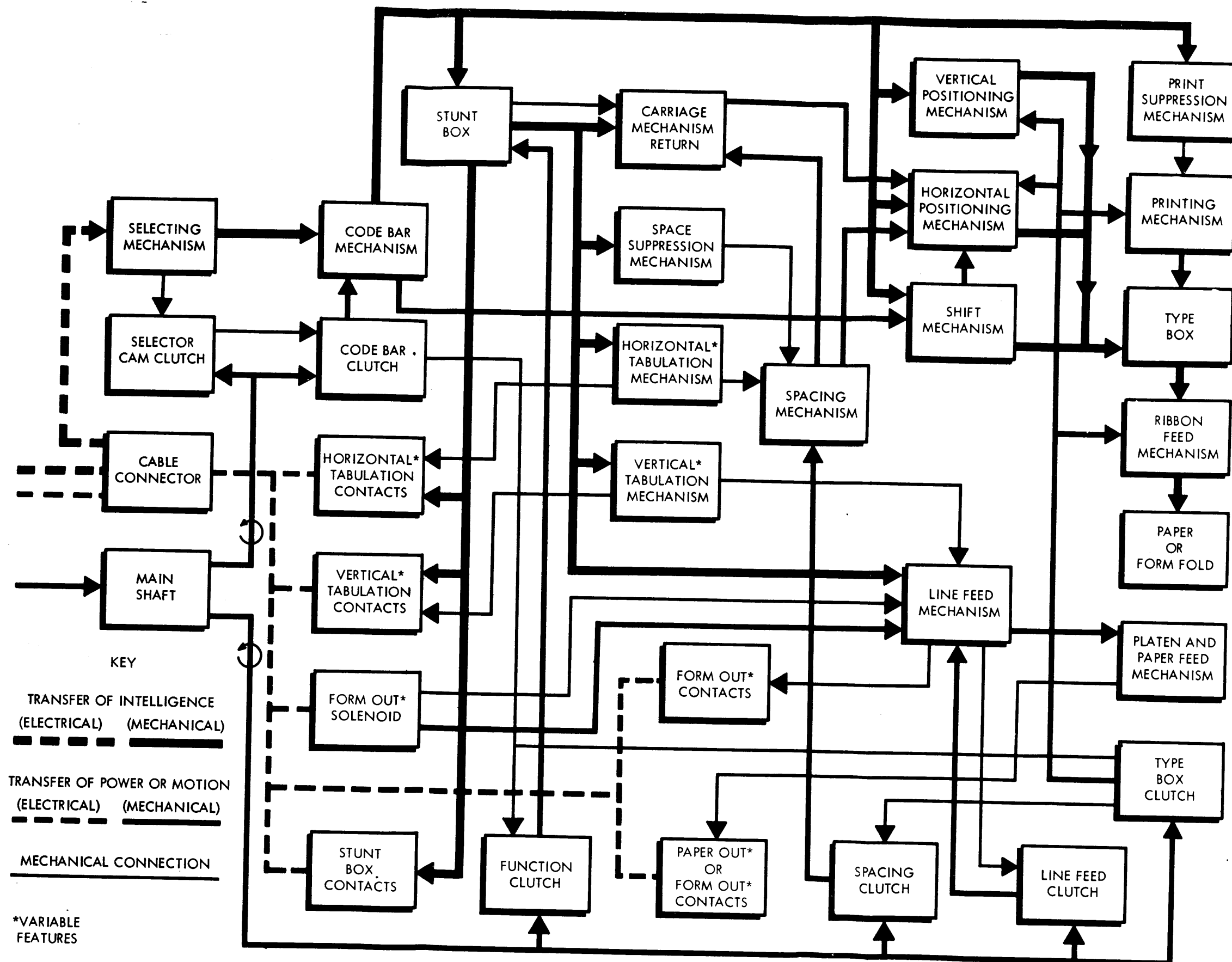

Figure 7 - 35 Typing Unit Block Diagram

2.15 The type box, positioned by the printing and spacing mechanisms in accordance with intelligence set up in the code bars, presents a single graphic in printing position for each unsuppressed operating cycle. At the proper moment, with the type box locked in printing position, a spring loaded print hammer is released to tap the selected type pallet sharply against the inked ribbon and the paper or form. A cleanly imprinted graphic character corresponding to the input signal code combination results, and the printing mechanism trips the spacing clutch to move both the type box and the print hammer to the next horizontal printing position to the right.

MAIN SHAFT (Fig. 8)

A. General

2.16 The main shaft is located in the lower rear portion of the typing unit, supported in the two side frames in ball bearings. It extends the full width of the printer.

2.17 Centrally located on the shaft are two driving gears. The larger gear meshes with the intermediate gear mechanism of the associated base or keyboard base to transmit power from the motor to the typing unit. The

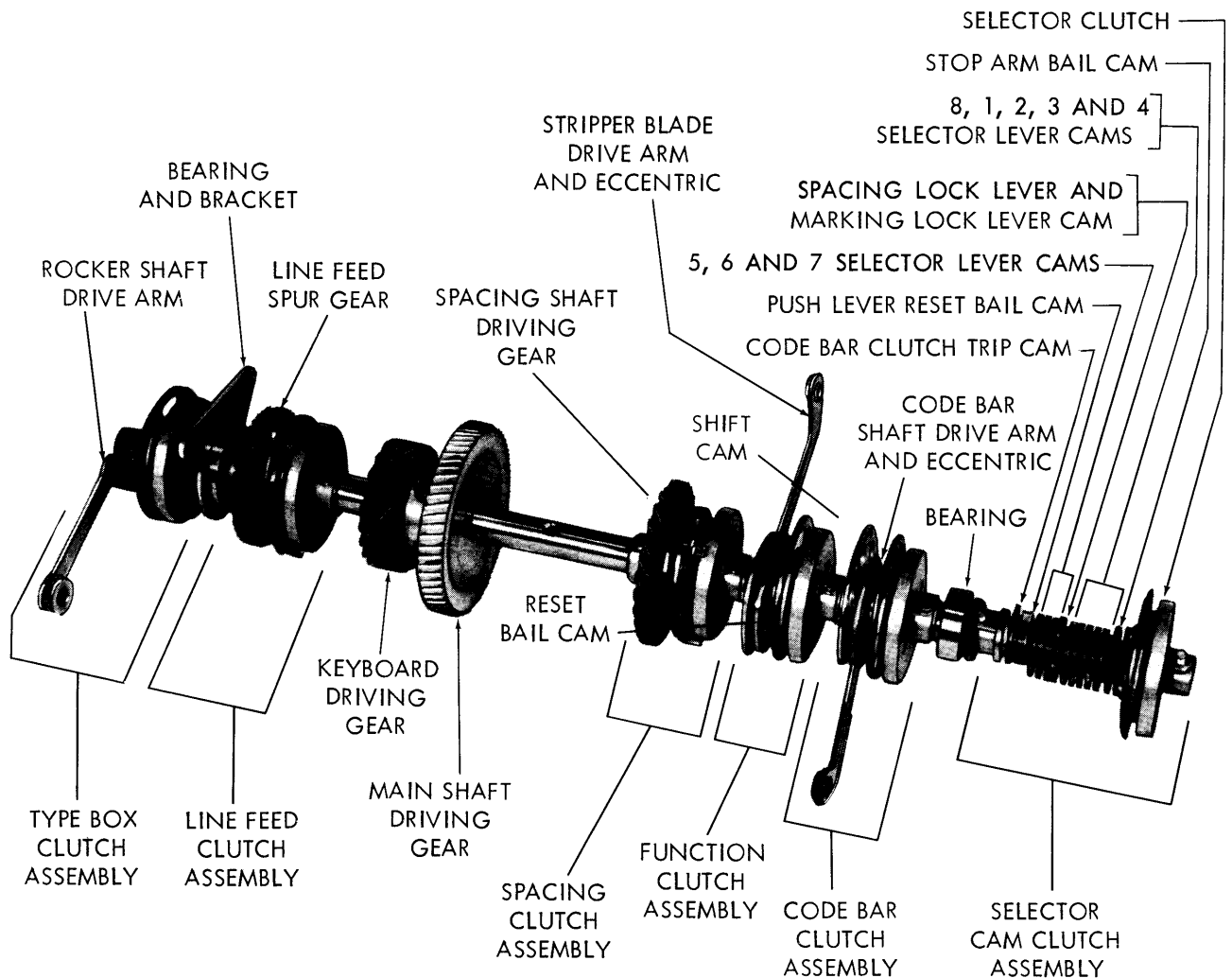

Figure 8 - Main Shaft

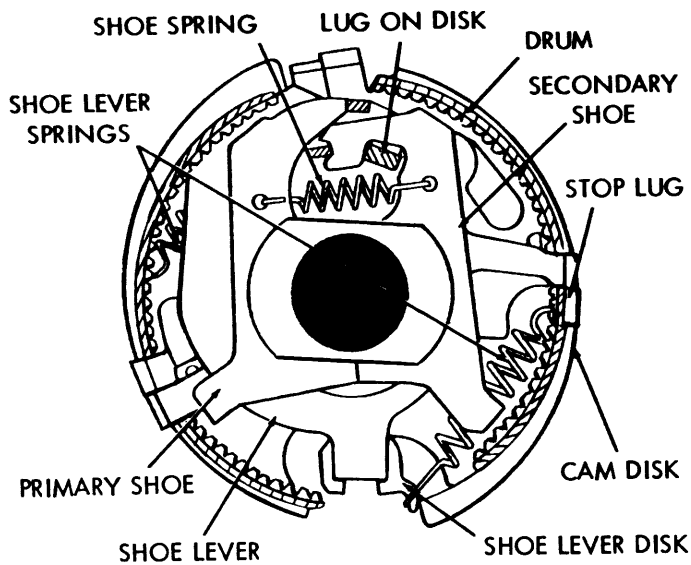

Figure 9 - Three Stop Clutch

smaller gear drives the signal generator mechanism of an associated keyboard base.

2.18 Power take off from the constantly rotating main shaft is controlled by six clutches, each of which, when tripped (engaged, or unlatched) drives its associated mechanism. From the right end of the shaft, these

clutches may be identified as the selector clutch (with cam sleeve), the code bar clutch, the function clutch, the spacing clutch, the line feed clutch and the type box clutch. The sequence in which these clutches are tripped is, selector, code bar, function, type box, spacing and line feed. However, the type box and spacing clutch engagement may be suppressed under certain operating conditions, and the line feed clutch is operative only upon a specific set of input signal code combinations.

2.19 The spacing and line feed clutches are three stop clutches (Fig. 9), each permitting their associated mechanism to operate through one-third of a revolution of the main shaft. All other clutches are one stop clutches (Fig. 10 and 11), operating through an entire revolution of the main shaft.

B. One Stop Clutches (Fig. 10 and 11)

2.20 The clutch drums are attached to and rotate with the main shaft (Fig. 8). In the disengaged position, as shown in Fig. 10, the clutch shoes do not contact the drum, and the shoes and cam disk are held stationary. Engagement is accomplished by moving the stop arm (Fig. 11) toward the rear of the typing unit, away from the clutch, thus releasing stop lug A and the lower end of shoe lever B (Fig. 11). The upper end of lever B pivots about its ear C,

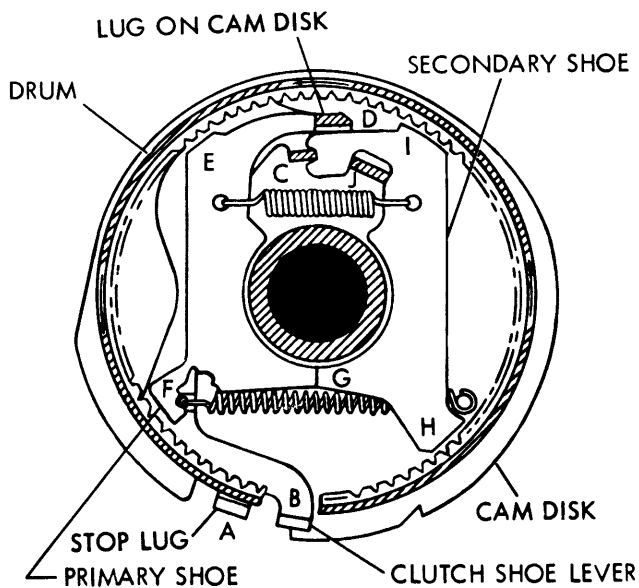

Figure 10 - One Stop Clutch (Disengaged)

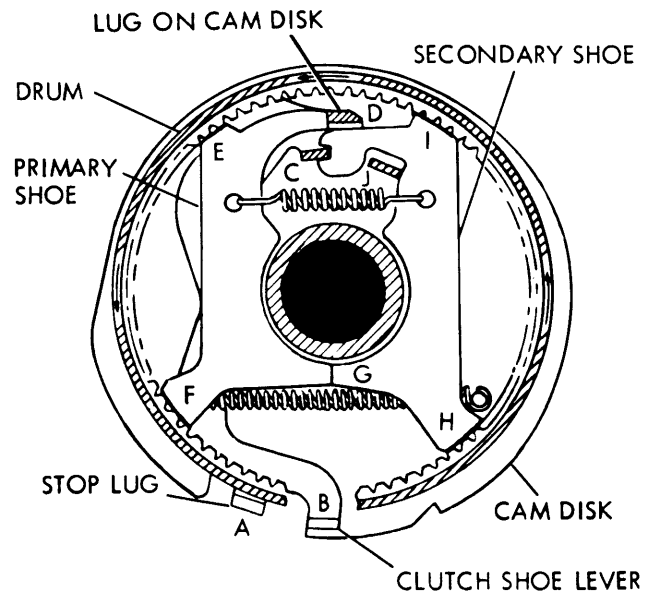

Figure 11 - One Stop Clutch (Engaged)

which bears against the upper end of the secondary shoe and moves its ear D and the upper end of the primary shoe toward the left until the shoe makes contact with the notched inner surface of the rotating drum at point E. As the drum turns counterclockwise, it drives the primary shoe downward so that it again makes contact with the drum at point F. There, the combined forces acting on the primary shoe cause it to push against the secondary shoe at point G. The lower end of the secondary shoe then bears against the drum at point I. The forces involved are multiplied at each of the preceding steps. The aggregate force is applied through the shoes to the lug J on the clutch cam disk, and the disk and attached cam turn in unison with the drum.

2.21 Disengagement is effected when the lower end of shoe lever B strikes the stop arm. Lug A and the lower end of the shoe lever are brought together (Fig. 10), and the upper end of lever B pivots about its ear C and allows its other ear D to move toward the right. The upper spring then pulls the two shoes together and away from the drum. The latch lever seats in the indent in the cam disk, and the cam is held in its stop position until the clutch is again engaged.

C. Three Stop Clutches (Fig. 9)

2.22 Two of the clutches, spacing and line feed, have three sets of lugs equally spaced about their periphery. The action is as described in Par. 2.20-2.21, but the clutch is permitted to rotate through only one-third revolution before the stop lever and latch lever halt its motion.

D. Six Stop Clutches

2.23 On the sprocket feed typing unit, the line feed clutch has six stops (instead of three, as on the friction feed typing unit). The six sets of lugs are equally spaced about their periphery and the action is the same as that described in Par. 2.20-2.21, but the clutch is permitted to rotate through only one-sixth revolution before the stop lever and latch lever halt its motion.

SELECTION

2.24 The selecting mechanism consists of two magnet coils, an armature with an anti-bounce stop, a selector cam clutch, and the associated levers, arms, bails and slides necessary to convert the electrical bits of the start-stop code to the mechanical arrangements which govern the character to be printed and the function to be performed. The selector cam clutch assembly comprises, from right to left (Fig. 8), the clutch; the stop arm bail cam; the eighth,

first, second, third and fourth selector lever cams; the cam for spacing and marking lock levers; the fifth, sixth and seventh selector lever cams; the push lever reset bail cam; and the code bar clutch trip cam.

2.25 During the time in which a closed line circuit (marking) condition exists, the selector magnet coils are energized and hold the selector armature against the selector magnet pole pieces. In this stop position, the selector armature blocks the start lever (Fig. 12). While the signal for any character or function is being received, the start (spacing) bit releases the selector armature which, under the tension of its spring, moves away from the magnet cores, and thus unlatches the start lever. The start lever rotates clockwise (as viewed from the right) under tension of its spring, moving the stop arm bail into the indent of the first cam. As the stop arm bail rotates about its pivot point, the attached stop arm is moved out of engagement with the clutch shoe lever. The selector cam clutch engages and begins to rotate. The stop arm bail immediately rides to the high part of its cam, where it remains to hold the start lever away from the selector armature during the reception of the signal code combination. When the stop bit at the end of the signal code combination is received, the selector armature is pulled up to block the start lever. Thus, the stop arm bail is prevented from dropping into the indent of its cam, and the attached stop arm is held so as to stop the clutch shoe lever. The clutch cam disk upon which the latch lever rides has an indent as its stop position. When the clutch shoe lever strikes the stop arm, the inertia of the cam disk assembly causes it to continue to turn until its lug makes contact with the lug on the clutch shoe lever. At this point, the latch lever drops into the indent in the cam disk, and the clutch is held disengaged until the next start bit is received.

2.26 The series of seven selecting levers (the eighth position, always marking, is not equipped with a selecting lever) and a marking lock lever ride their respective cams on the selector cam clutch. As the marking or spacing signal bits are applied to the selector magnets, the selector cam clutch rotates and actuates the selector levers. When a spacing bit is received, the marking lock lever is blocked by the end of the armature, and the spacing lock lever swings toward the rear, above the armature, and locks it in the spacing position until the next signal bit is received. Extensions on the marking lock lever prevent the selector levers from

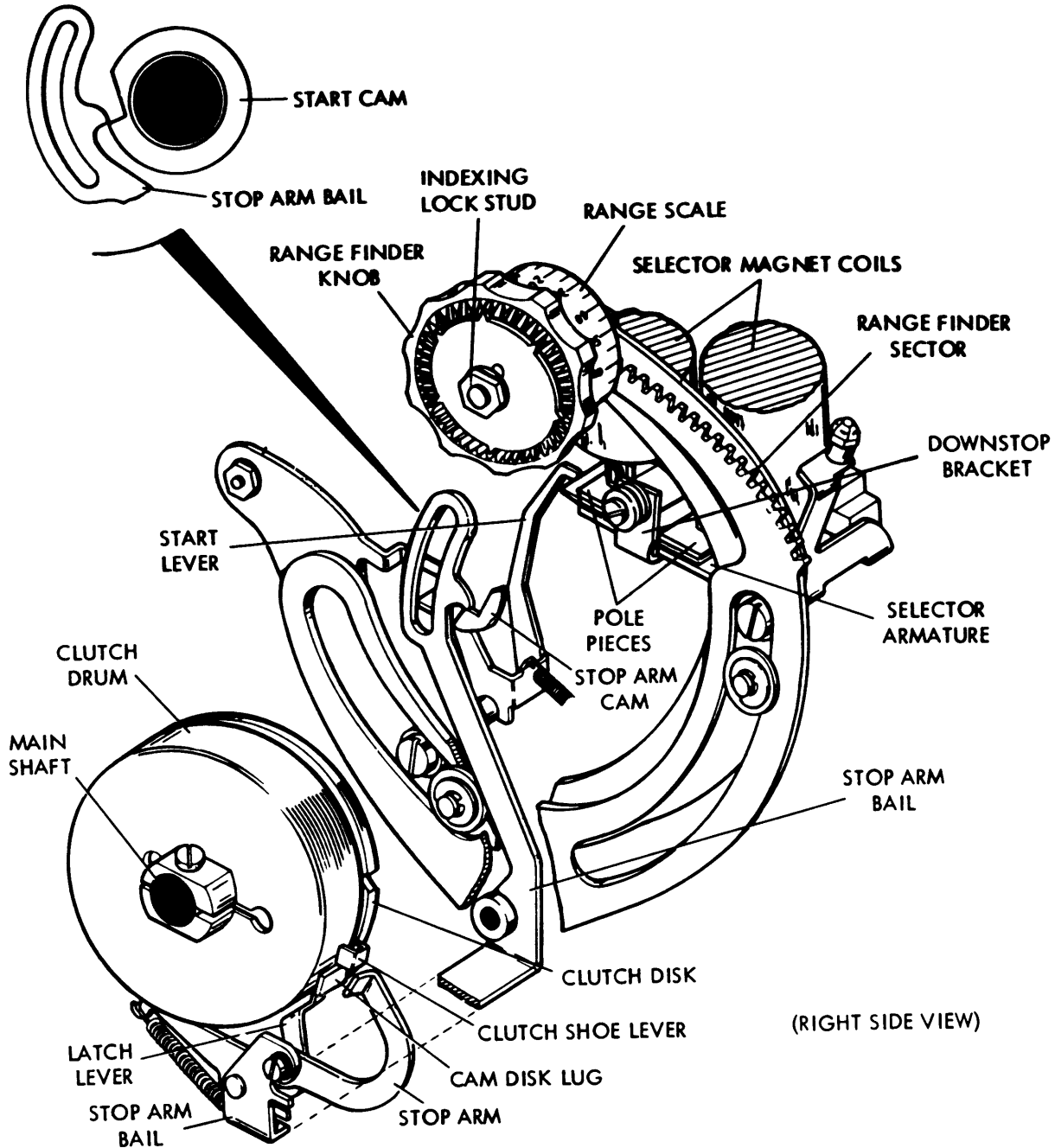

Figure 12 - Selector Clutch and Range Finder

following their cams (Fig. 13). When a marking bit is received, the spacing lock lever is blocked by the end of the armature, and the marking lock lever swings to the rear, below the armature, to lock it in the marking position until the next signal bit is received. During this marking condition, the selector levers are not blocked by the marking lock lever and are permitted to move against their respective cams.

The selecting lever that is opposite the indent in its cam while the armature is locked in marking condition swings to the rear, or selected, position momentarily.

2.27 Each selecting lever has an associated push lever which drops into a notch on the top of the selecting lever when the selecting lever falls into the indent in its cam. As the

selector cam clutch rotates, each selecting lever is moved forward as it rides to the high part of its cam. Selected (dropped) push bars are also moved forward. Unselected push bars remain in the rear position, on top of the notch of the selecting lever. When all seven code bits have been received, push levers are held in their selected or unselected position until the next start bit is received.

2.28 When the subsequent start bit is received, the cam clutch is again engaged. The

push lever reset bail, following its cam, unlatches the selected push levers. The push levers then return to their unselected (rear) position under their spring tension.

ORIENTATION

2.29 In order to establish the operating margins for the typing unit, it is necessary that the sampling of the signal by the selecting mechanism occur at the most favorable portion of the signal element. This is referred to as orientation.

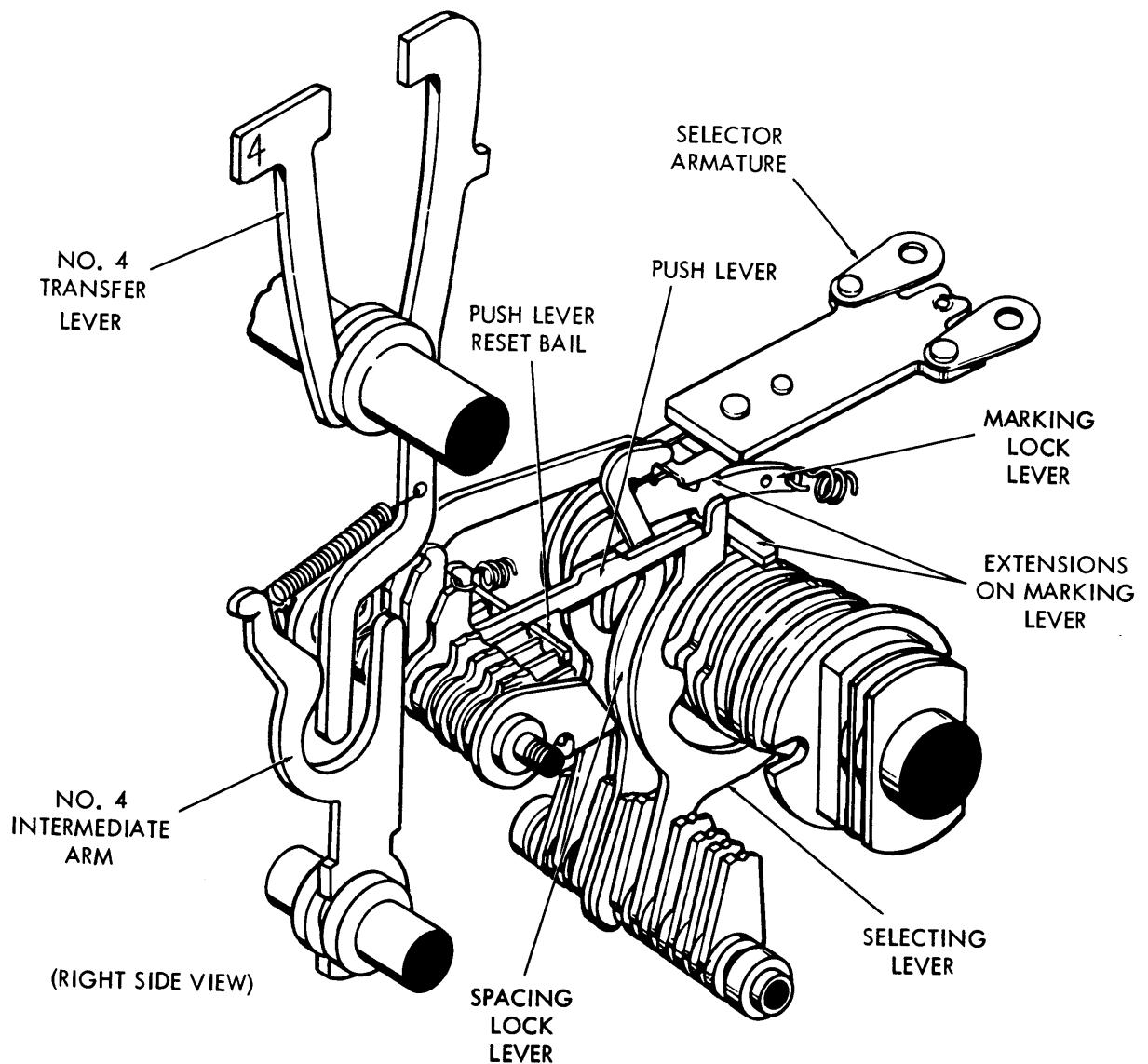

Figure 13 - Selecting Mechanism and Transfer Mechanism

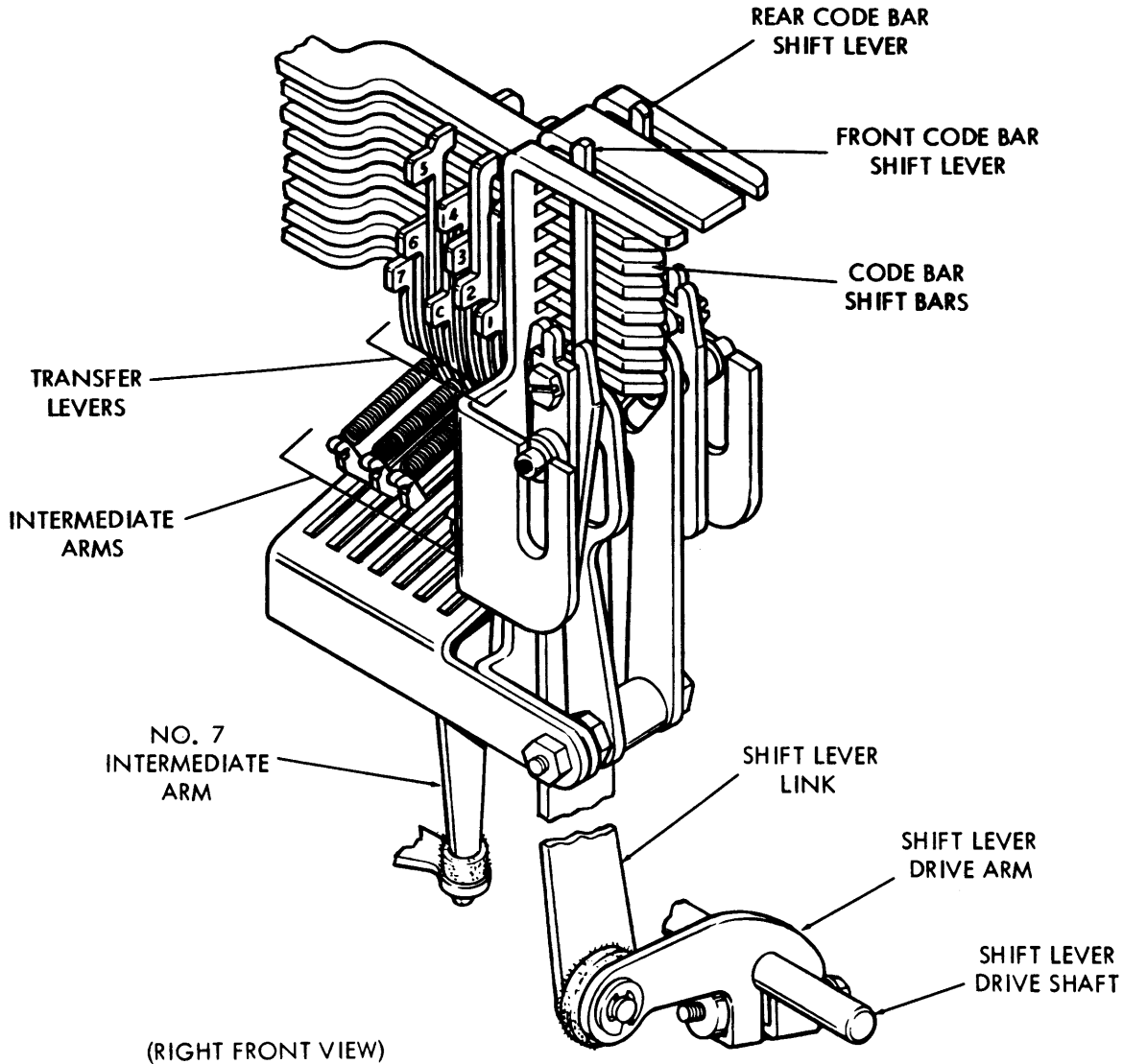

Figure 14 - Code Bar Mechanism

2.30 When the range finder knob (Fig. 12) is pushed inward and rotated, its attached range finder gear moves the range finder sector (which mounts the stop arm bail, stop arm and latch lever) either clockwise or counterclockwise about the selector cam clutch. This changes the angular position at which the selector cam clutch stops with respect to the selecting levers. When an optimum setting is obtained, the range finder knob is released. Its inner teeth engage the teeth of the indexing lock stud to lock the range finder mechanism in position. The setting may be read on the range finder scale opposite the fixed index mark.

PRINTING MECHANISM

A. Code Bar Mechanism (Fig. 14)

General

2.31 The character printed or the function executed by the typing unit is basically determined by the code bar mechanism, to which the input signal intelligence, translated into mechanical form, is transmitted from the selecting mechanism push bars. The code bars are positioned by code bar shift bars which move to the left for marking and to the right

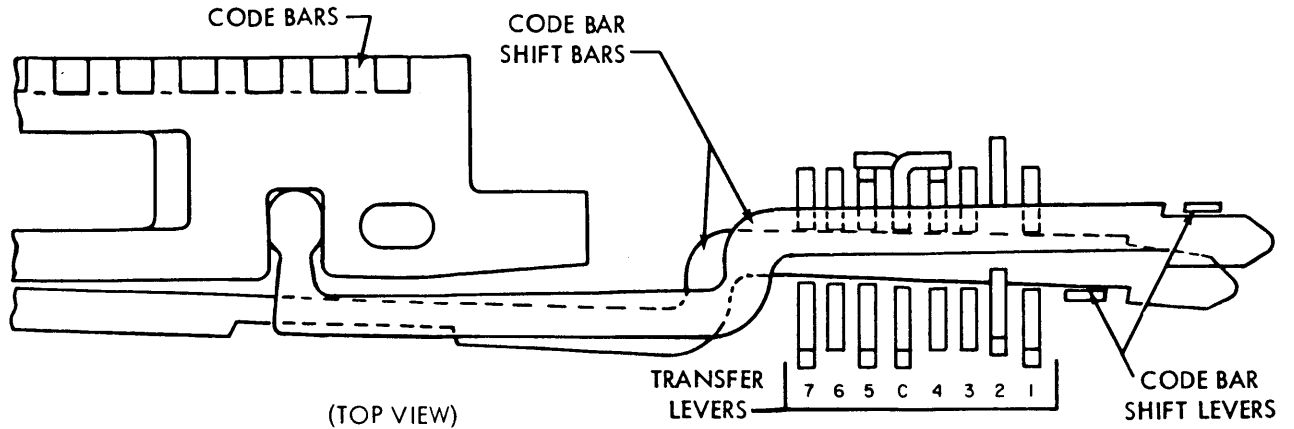

Figure 15 - Code Bar Shift Bar Positioning

for spacing. The shift bars, positioned to the rear for marking and forward for spacing, are pushed into marking position by selected push bars through a mechanical linkage intermediate arms and transfer levers.

2.32 Power to position the selected code bar levers, and through them the code bars, is supplied by the code bar clutch. The code bar clutch is engaged by its cam on the selector cam clutch (Par. 2.24). The code bar clutch also drives a cam through which the shift mechanism is operated and the function and type box clutches are engaged.

2.33 At the left end of the code bar mechanism, a printing suppression mechanism is operated by the code bars. The blocking levers are rotated by the code bars to prevent release of the type box clutch trip lever through a blocking bail.

Code Bar Positioning (Fig. 14, 15 and 16)

2.34 Each selector push lever (Par. 2.26) has an associated intermediate arm, transfer lever and code bar shift bar (Fig. 14). In addition, there is a common transfer lever with its code bar shift bar. When a push lever is toward the rear (spacing) its associated intermediate arm and transfer lever are pulled toward each other by a spring. The upper end of the transfer lever is held forward (spacing), holding the code bar shift bar in spacing position. When a push lever is moved forward (marking), it rotates the intermediate arm counterclockwise, positioning the transfer lever

to the rear (marking) and holding the code bar shift bar in marking position. The common transfer lever (fourth from left, operating the common code bar, third from bottom) has two extensions which pass behind the numbers 4 (to the right) and 5 (to the left) transfer levers. There is no connection between the common transfer lever and the selecting mechanism, but when either the number 4 or number 5 push bar is selected, the associated transfer levers position the common code bar shift bar to the rear (marking). The right ends of these code bars determine vertical positioning of the type box (Fig. 16).

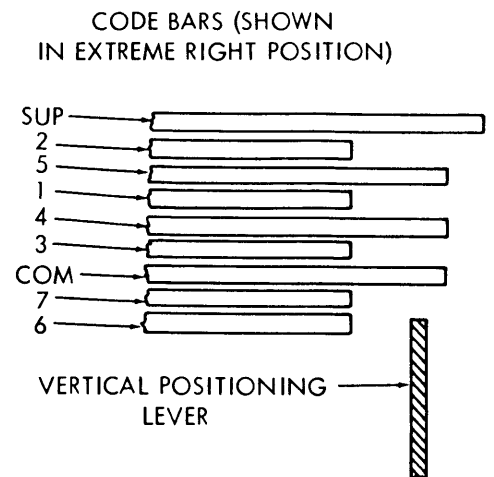

Figure 16 - Vertical Arrangement of Code Bars

2.35 As the selector cam clutch completes its revolution, the trip shaft operating lever rides to the peak of the code bar clutch trip cam (Fig. 8). This causes the shaft to turn slightly (counterclockwise, viewed from the right) to move the code bar clutch trip lever away from the clutch stop lug and engage the clutch. Rotation of the clutch operates an eccentric and the shift lever drive shaft, shift lever drive arm and shift lever drive link. The drive link moves two code bar shift levers in a scissors like action, the front lever moving to the left, the rear lever moving to the right. Any code bar shift bar in marking position (left) during the previous operating cycle is moved to spacing position (right) by the forward shift lever, unless the transfer lever is once again holding that bar to the rear (marking). The rear shift bar, as it moves to the left (Fig. 15) carries with it any code bar shift bar held in the marking position, completing the transfer of intelligence from the selecting mechanism to the code bars.

2.36 At the end of one revolution, the code bar clutch trip lever strikes the clutch shoe lever. Inertia of the cam disk assembly causes it to continue to turn to permit the latch lever to drop into the indent in the cam disk, and the clutch is held disengaged. The code bars, code bar shift bars and shift levers are held in the selected position, but the transfer levers and intermediate arms are free to position the shift bars forward or to the rear in response to new input signal intelligence from the selector.

Arrangement of Code Bars (Fig. 16)

2.37 A total of nine code bars in marking (left) or spacing (right) position convey mechanically translated signal intelligence to the typing and function mechanisms. The code bars are arranged from top to bottom as follows: suppression, number 2, number 5, number 1, number 4, number 3, common, number 7 and number 6. In the typing units as furnished, a disabling clip engages a notch at the left end of the upper (suppression) code bar. This code bar, when used, is operated by the function box for print suppression through the print suppression mechanism (Par. 2.56 - 2.59). There is no shift bar and transfer mechanism linkage for the suppression code bar.

B. Type Box and Type Box Carriage

General

2.38 All of the characters (graphics) that may be printed by the typing unit are formed

by type pallets which are arranged in a type box. The type box is mounted in a carriage from which it may be removed for cleaning or replacement. In order to print any selected character, the type box carriage is so positioned that the character on the pallet is directly over the desired location on the paper. Since the pallets are arranged in four horizontal rows and sixteen vertical rows, it is necessary to position the type box carriage both horizontally and vertically. See Fig. 17 for arrangement of graphics which are represented on the type box pallets. See Fig. 6 for input signal code permutations equivalent to each graphic representation.

2.39 The type box carriage rides on rollers over a track which is moved vertically for positioning in that particular plane. The carriage is positioned horizontally on its track by the oscillating rail slide and type box carriage link. The slide rides the oscillating rail and is clamped to the rear section of the upper draw wire rope. The link provides a flexible connection to permit the type box carriage to follow both the vertical movement of the type box carriage track and the horizontal movement of the oscillating rail slide.

2.40 The lower right rear end of the upper draw wire rope is fastened to the spacing drum. From this point, it passes part way around the spacing drum, upward and around the right rail pulley and downward to the spring drum. After passing part way around the spring drum, the upper draw wire rope is doubled backward around it and passes upward to the left printing carriage rail pulley over to the right printing carriage rail pulley, and downward to the spacing drum to which it is again fastened. The lower draw wire rope is fastened at its left end to the spring drum and, at its right end, to the spacing drum. It acts in opposition to the upper draw wire rope and holds the two drums in phase (Fig. 18). A tensioning pulley rides the under side of the lower draw wire rope, to take up any slack which may occur due to stretching of the upper and lower draw wire ropes.

2.41 The oscillating rail is supported by pivoted arms at each end. These arms which extend downward are pivoted on the typing unit frame at their lower ends. Thus, the oscillating rail and draw wire rope that it carries with it may be shifted to the left or right with no change in position relative to each other. The oscillating rail shift slide and two oscillating rail shift links are used to accomplish the horizontal positioning of the oscillating rail and also connect it with the oscillating rail

7S = FIGURES FIELD								7M = LETTERS FIELD							
IM	IS	IM	IS	IS	IM	IS	IM	IM	IS	IM	IS	IS	IM	IS	IM
2M	2M	2S	2S	2S	2S	2M	2M	2M	2M	2S	2S	2S	2S	2M	2M
3M	3M	3M	3M	3S	3S	3S	3S	3M	3M	3M	3M	3S	3S	3S	3S
▼	8	%	\$	NO PALLE T	!	▼▼	#	G	F	E	D	@	A	B	C
123- -6-8	-23- -6-8	1-3- -6-8	--3- -6-8	1- -6-8	1- -6-8	-2- -6-8	12- -6-8	123- -78	-23- -78	1-3- -78	--3- -78	--- -78	1- -78	-2- -78	12- -78
7	6	5	4	0	1	2	3	W	V	U	T	P	Q	R	S
123- 56-8	-23- 56-8	1-3- 56-8	--3- 56-8	--- 56-8	1- 56-8	-2- 56-8	12- 56-8	123- 5-78	-23- 5-78	1-3- 5-78	--3- 5-78	--- 5-78	1- 5-78	-2- 5-78	12- 5-78
/	.	-	,	()	*	+	O	N	M	L	H	I	J	K
1234 -6-8	-234 -6-8	1-34 -6-8	--34 -6-8	---4 -6-8	1-4 -6-8	-2-4 -6-8	12-4 -6-8	1234 -78	-234 -78	1-34 -78	--34 -78	---4 -78	1-4 -78	-2-4 -78	12-4 -78
?	>	=	<	8	9	:	;	←	↑] \		X	Y	Z	[
1234 56-8	-234 56-8	1-34 56-8	--34 56-8	---4 56-8	1-4 56-8	-2-4 56-8	12-4 56-8	1234 5-78	-234 5-78	1-34 5-78	--34 5-78	---4 5-78	1-4 5-78	-2-4 5-78	12-4 5-78

Figure 17 - Type Box Pallet Arrangement

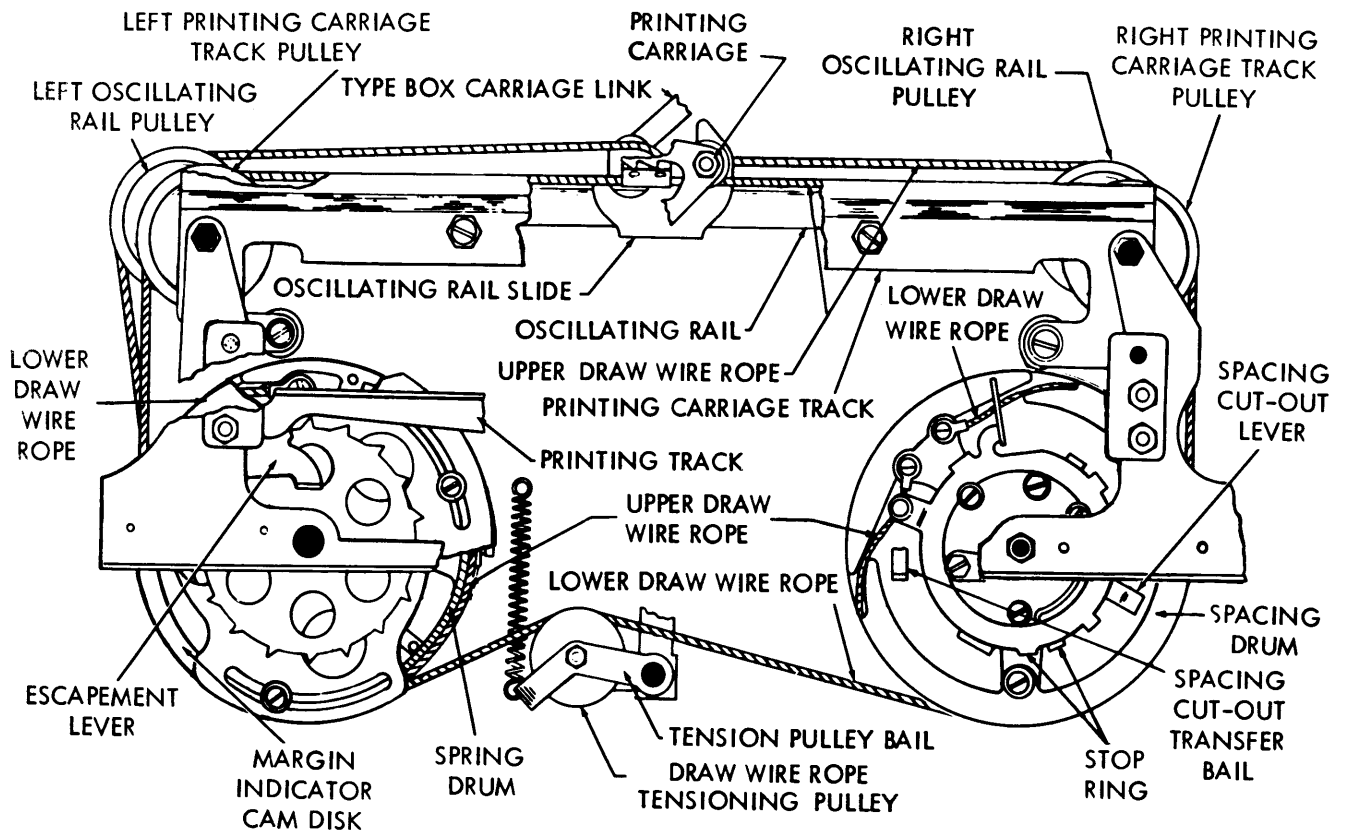

Figure 18 - Draw Wire Rope and Drums

shift slide. The links are pivoted and are such a length that only one at a time may be fully extended.

Shift Mechanism (Fig. 19)

2.42 Mechanical limitations of the equipment restrict selection from the type box pallets to four horizontal and eight vertical rows. Since there are sixteen vertical rows in the type box, a means is provided for determination of which of two fields, figures (left half of the type box) or letters (right half of the type box), will be presented for positioning. This is accomplished by the shift mechanism, operation of which is initiated by the code bar

mechanism. The seventh bit in the input signal code determines the field selection as figures (number 7 spacing) or letters (number 7 marking).

2.43 Two pawls on the shift selector arm (Fig. 19) are positioned left (spacing) or right (marking) by a tail descending from the seventh code bar mechanism intermediate arm. The selector arm and its pawls are mounted to the lower front corner of the right side plate and extend through slots in two shift pawls on the rear of the front plate mechanism. When moved (simultaneously) to the left (spacing) position, the shift pawls are positioned so that the shift drive pawl, driven upward by the code bar clutch shift lever cam shaft, would strike the right pawl,

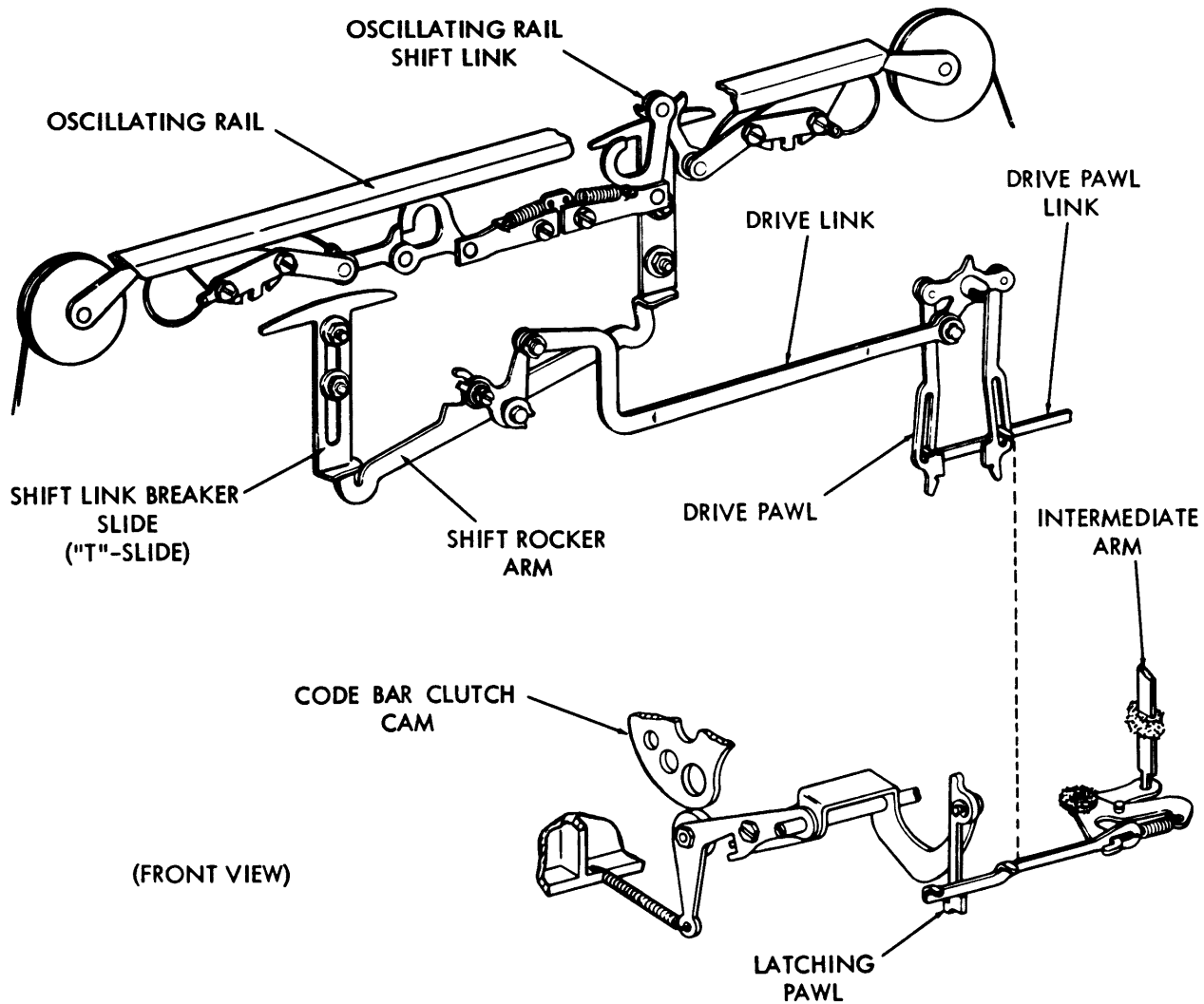

Figure 19 - Shift Mechanism

driving it upward. When moved to the right (marking), the shift drive pawl lifts the left pawl. If the right shift pawl is already raised, a spacing signal on the seventh intelligence bit would not affect the shift mechanism. A marking signal would not affect the mechanism when the left pawl is raised in the preceding operating cycle.

2.44 The left and right shift pawls operate a toggle on the rear of the front plate mechanism, rotating the toggle clockwise for marking, counterclockwise for spacing. The toggle is linked to the shift rocker lever (Fig. 20). When rotated clockwise, the shift rocker lever initiates a figures (number 7 code bar spacing) shift. When rotated counterclockwise, the shift rocker lever initiates a shift to the letters field. The rocker bail raises the left or right shift breaker slide, breaking the oscillating rail shift links above the raised slide. This permits the oscillating rail to shift to the opposite end of its travel limits, setting up the figures field for printing when moved to the right and the letters field when moved to the left.

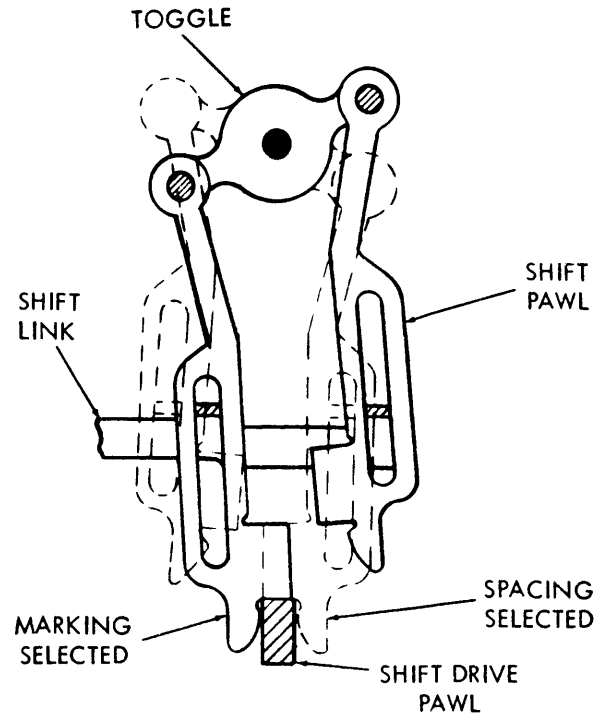

Figure 20 - Shift Mechanism Positioning

Type Box Positioning

2.45 The selection of the various characters from the four horizontal rows and eight vertical rows in either field (figures or letters) and the printing of those characters take place as follows:

2.46 The number 4 and number 5 code bars determine the selection of the horizontal row. The number 3 code bar determines whether the selection is to be made from the left four vertical rows (in either the figures or the letters field, as determined by the shift mechanism, Par. 2.42-2.44) or the right four vertical rows. The number 1 and number 2 code bars determine the selection of one row from the four vertical rows predetermined by the number 3 code bar.

2.47 Four code bars (longer than the others) extend through the right code bar bracket and serve as stops for the right vertical positioning levers (Fig. 21). They are (from top to bottom) the suppression, number 5, number 4 and common code bars. Notches are arranged in the left ends of these code bars so that the left side vertical positioning levers are stopped, in each case, by the same bar that blocks the right side levers. After all code bars have been positioned by the code bar positioning mechanism, the code bar clutch cam follower arm and its roller, in traversing the sloping

indent on the code bar clutch cam, rotates the clutch trip lever shaft. As the shaft turns, it first causes the function clutch lever to release the function clutch (Fig. 22) and then causes the type box clutch trip arm to engage its trip lever and release the type box clutch. When the type box clutch completes its revolution, it is disengaged by its trip lever and latch lever in the same manner as was the code bar clutch (Par. 2.36). During its rotation, the type box clutch operates a drive link and a bracket to cause the main rocker shaft to oscillate. This, in turn, through its left and right brackets and the main side drive links, extends the motion to the vertical positioning levers (Fig. 21). These levers are driven upward until they strike a projecting code bar, which causes them to buckle. The type box carriage track is mounted between the vertical positioning levers, and its vertical motion is controlled by them.

2.48 When the number 4 and number 5 code bars are toward the right (spacing), the common code bar is also toward the right, where it blocks the vertical positioning levers. The top row of pallets in the type box are in line for printing. When the number 5 code bar is toward the left (marking), the common code

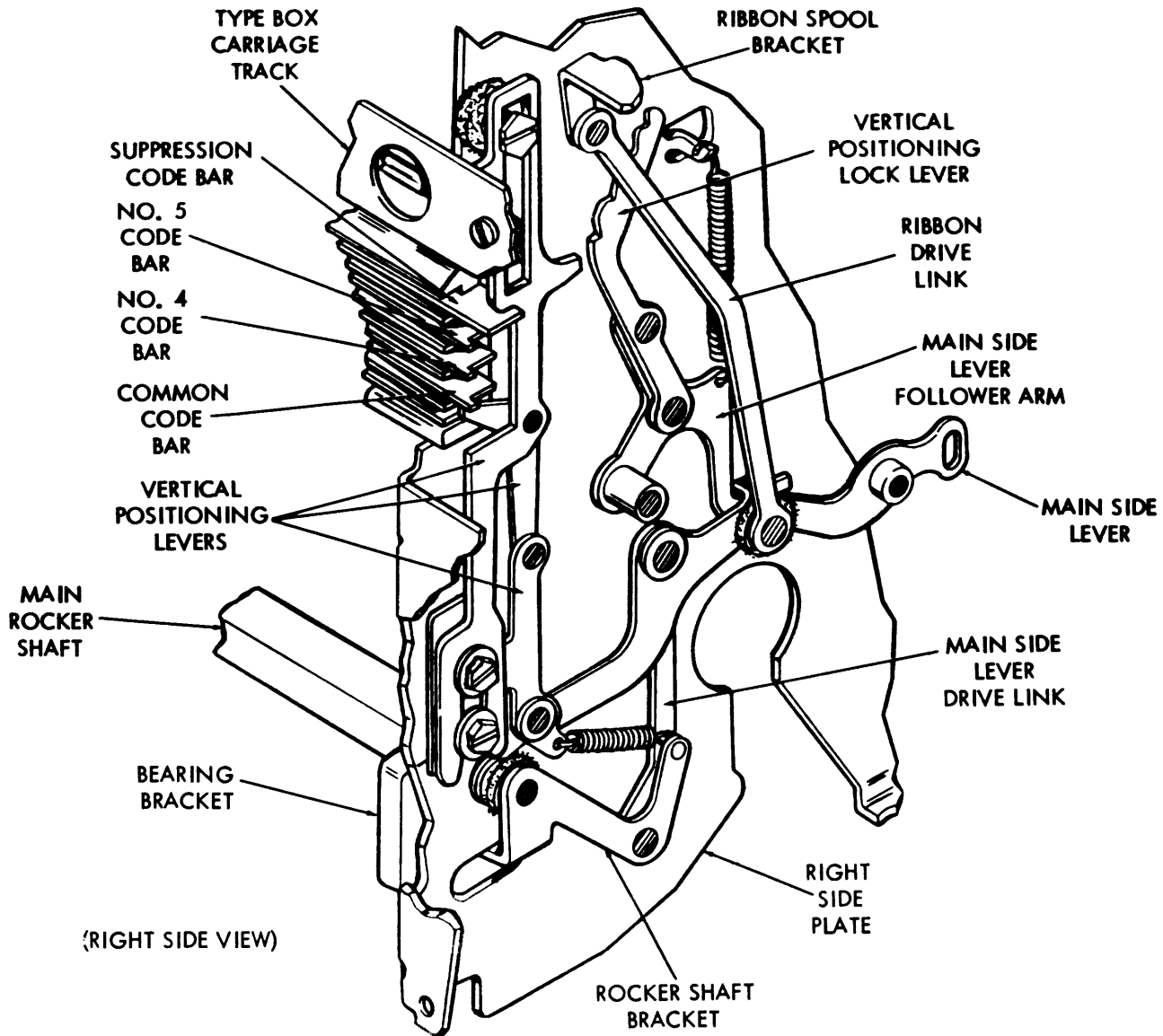

Figure 21 - Right Side Plate Mechanisms

bar is toward the left. If the number 4 code bar is toward the right (spacing), it blocks the vertical positioning levers, and the second row of pallets (from the top) are then in line for printing. When the number 4 code bar is toward the left (marking), the common code bar is toward the left. If the number 5 code bar is toward the right (spacing), it blocks the vertical positioning levers, and the third row of pallets is in line for printing. When both the number 4 and number 5 code bars are to the left (marking), the common code

bar is also to the left. The print suppression code bar blocks the vertical positioning levers, and the fourth (bottom) row of pallets in the type box are then in line for printing. At each of the four levels at which the vertical positioning levers may be stopped, they are locked momentarily by lock levers controlled by the main side lever follower arms.

2.49 A bracket attached to the main rocker shaft applies vertical motion to the main

bail by means of two main bail links (Fig. 23). Attached to each end of the oscillating rail shift slide are pivoted buckling type drive links which extend downward to each end of the main bail. As the main bail moves downward under impetus of the type box clutch, the left shift slide links, if not buckled, will try to shift the oscillating rail slide drive links toward the right, while the right shift slide drive links, if not buckled, will try to shift the oscillating rail shift slide links to the left. When the number 3 code bar is shifted toward the left (marking), the horizontal motion reversing slide is shifted toward the left by the reversing slide shift lever and is held there by detent levers. A bracket near the right end of the reversing slide will then make contact with the right shift slide drive links and cause them to buckle. As the main bail is driven downward, the unbuckled left shift slide drive links will start to shift the oscillating rail shift slide toward the right. This positions the type box so that the characters to be printed will be located in the left half of the figures or the letters field. In a similar manner, when the number 3 code bar is shifted toward the right (spacing), the horizontal motion reversing slide is also shifted toward the right by the shift lever and is held there by the detent levers. A bracket near the left end of the horizontal motion reversing slide

then makes contact with the left shift slide drive links and causes them to buckle. As the main bail is driven downward, the unbuckled right shift slide drive links will start to shift the oscillating rail shift slide toward the left. This positions the type box so that the characters to be printed will be located in the right half of the figures or the letters field.

2.50 After determination of the field (figures or letters) and the group of vertical rows in which the character to be printed is located, the number 1 and number 2 code bars operate three horizontal motion stop slides to determine the row in that group in which the character is to be found (Fig. 23). A wedge shaped horizontal positioning lock lever which is pulled downward by the main bail through a yield spring bears against the horizontal positioning lock lever arm. This arm drives the oscillating rail shift slide in the direction in which it was started (by the number 3 code bar selection) until one of two decelerating slides which are mounted on the oscillating rail shift slide strikes an unselected horizontal motion stop slide. A camming surface on the unbuckled shift slide drives the decelerating slide and causes the drive links to buckle. The oscillating rail shift slide finally comes to rest when it

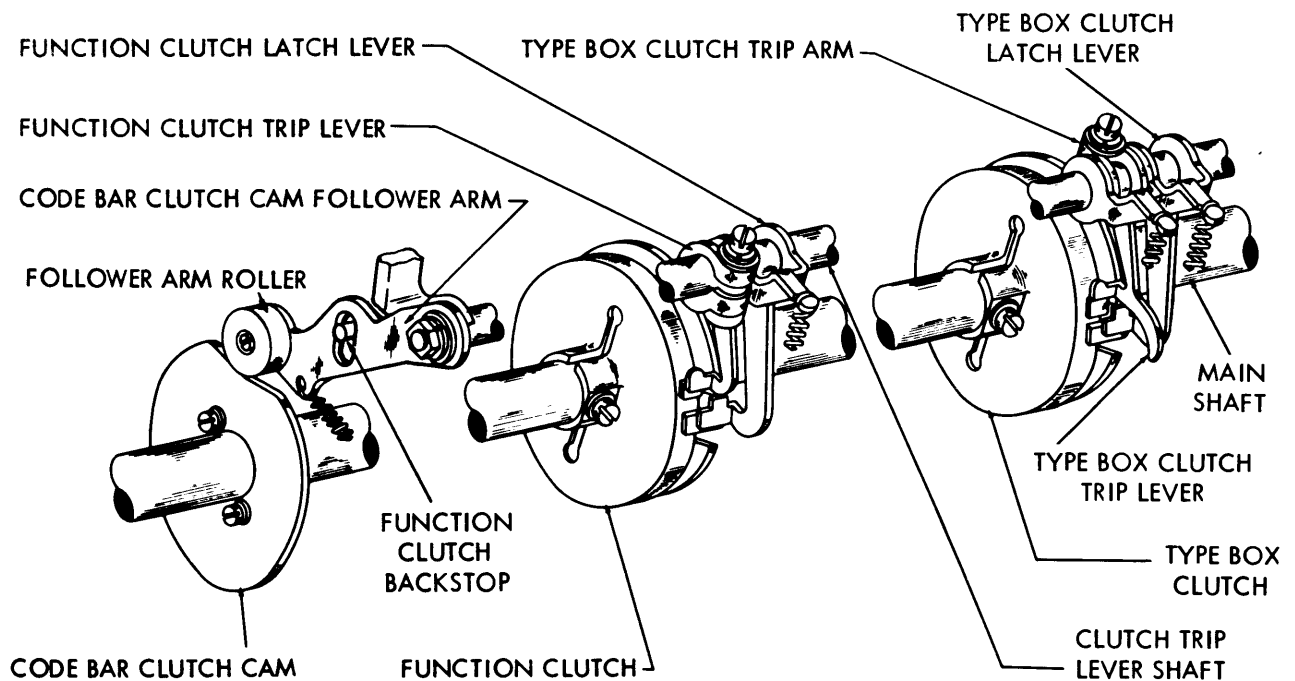
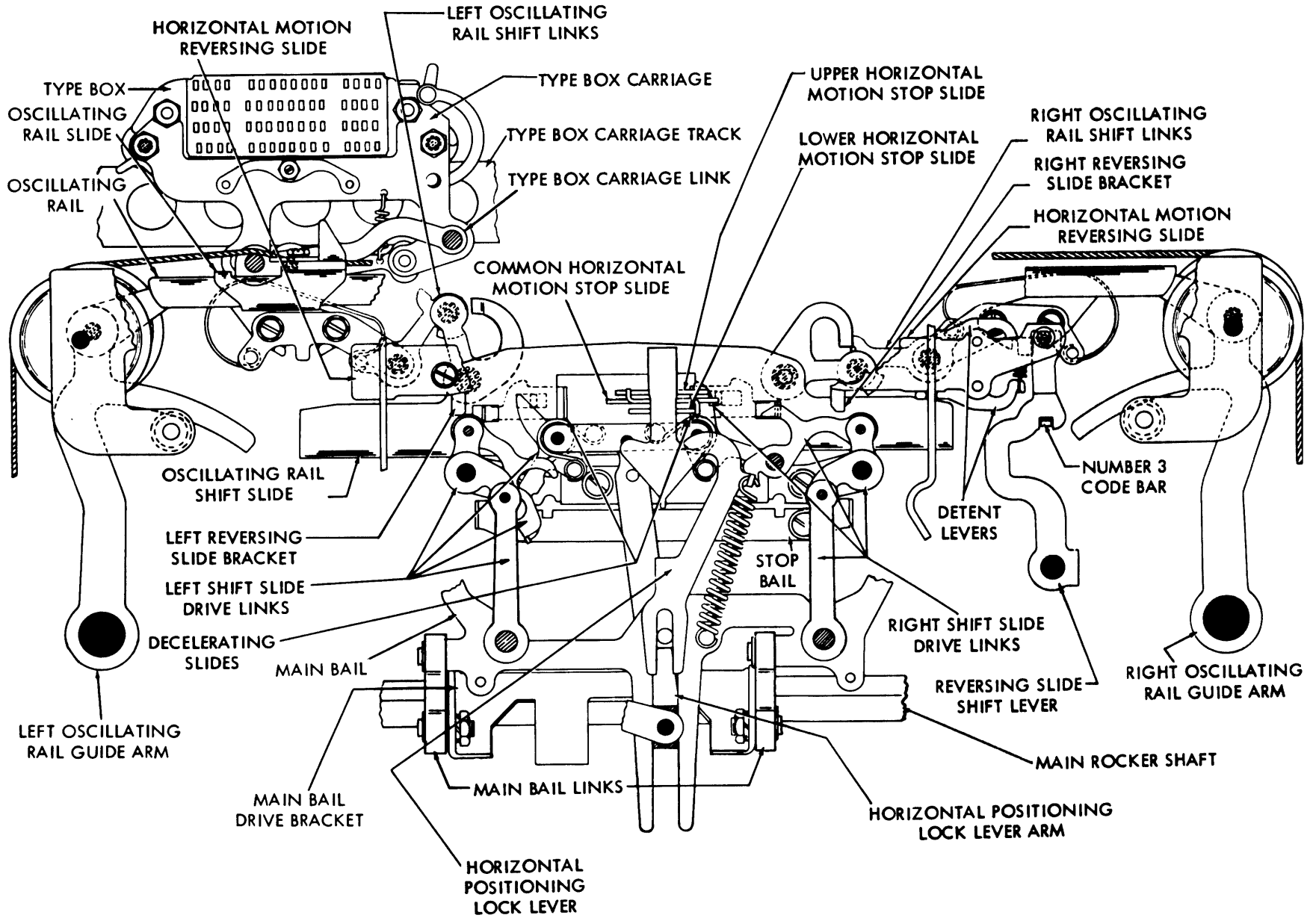

Figure 22 - Clutch Trip Mechanisms

Figure 23 - Horizontal Positioning Mechanisms



strikes the blocked decelerating slide. This, in turn, ends the downward excursion of the lock lever, and the yield spring extends until the main bail reaches the lowest point of its oscillation. As the main bail returns upward, it centers the oscillating rail shift slide. It is during this time that the horizontal motion stop slides are positioned for the selection of the next character. The number 1 and number 2 code bars each operate a code bar bail bell crank. Each, in turn, moves a horizontal motion stop slide toward the front (marking) or toward the rear (spacing) (Fig. 24). A third (common) stop slide (spring tensioned toward the rear) is located between the upper and lower stop slides and has projections which pass across the front edges of these slides (Fig. 23). Each stop slide is of a different length. The common stop slide, which is the longest stop, has an additional stop on its shank, so that it serves as the shortest stop when all the slides are moved forward. The upper slide (operated from the number 2 code bar) is the second longest stop, and the lower slide (operated from the number 1 code bar) is the third longest stop.

2.51 When both the number 1 and number 2 code bars are moved toward the right (spacing), their respective horizontal motion stop slides are toward the rear. The oscillating rail shift slide is moved to the right or left of its central position (determined by the number 3 code bar) until it is stopped by one end of the common horizontal motion stop slide. This positions the first vertical row (right or left of the center of the figures field or the letters field) in line for printing. When the number 2 code bar is toward the right (spacing), and the number 1 code bar is toward the left (marking), the lower and the common stop slides are toward the front, and the upper stop slide is toward the rear. The oscillating rail shift slide is moved to the right or left of its central position until it is stopped by one end of the upper stop slide. This positions the second vertical row (right or left of the center of the figures field or the letters field) in line for printing. When the number 2 code bar is toward the left (marking) and the number 1 code bar is toward the right (spacing), the upper and the common stop slides are toward the front and the lower stop slide is toward the rear. The oscillating rail shift slide is moved toward the right or left of its central position until it is stopped by one end of the lower stop slide. This positions the third vertical row (right or left of the center of the figures field or the letters field) in line for

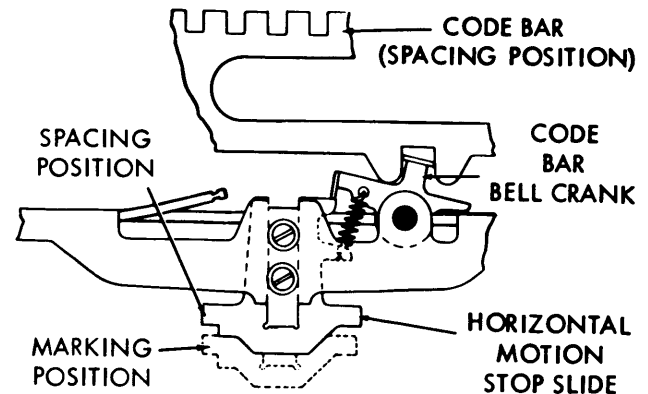

Figure 24 - Stop Slide Positioning

printing. When both the number 1 and the number 2 code bars are toward the left (marking), their respective horizontal motion stop slides and the common stop slide are toward the front. The oscillating rail shift slide is moved toward the right or left of its central position until it is stopped by one side of the shank of the common stop slide. This positions the fourth vertical row (right or left of the center of the figures field or the letters field) in line for printing.

C. Print Hammer and Printing Carriage (Fig. 25)

General

2.52 After the type box has been moved so that the selected type pallet is in its proper position, it must be struck by a print hammer in order to print. This is accomplished by the action of the printing carriage located on the printing carriage track at the top of the front plate mechanism.

Positioning

2.53 The printing carriage rides on rollers on the printing carriage track, which is rigidly attached to the typing unit front plate. The carriage is clamped to the forward section of the upper draw wire rope. This moves the carriage along its track in such a manner that the hammer advances to the next printing position after each character (graphic) is imprinted.

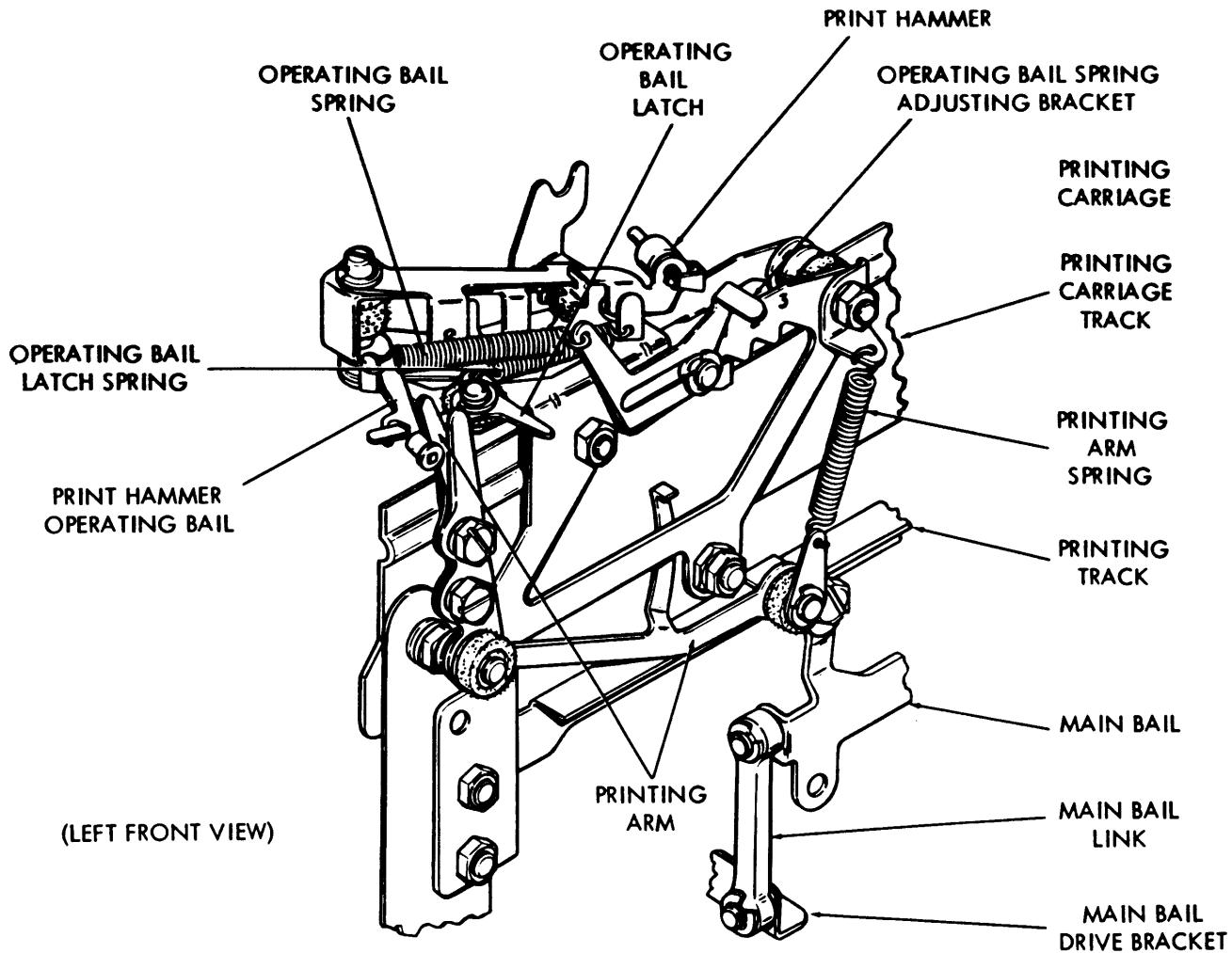

Figure 25 - Print Hammer and Carriage

Printing

2.54 The printing track which is located on the front of the typing unit (Fig. 25) is fastened to an extension at each end of the main bail. As the main bail reciprocates vertically, it extends the motion through the printing track, which travels in guides located at each end of the track. The printing arm, which extends downward from the printing carriage, rides the printing track. As the arm follows the reciprocating motion of the track, its upper end moves first toward the left and then toward the right. When the upper end of the arm moves toward the left, it rotates the print hammer operating bail

clockwise against its spring tension until it becomes latched by the operating bail latch.

2.55 The print hammer operating bail draws the print hammer away from the type box by means of the print hammer bail spring. When the upper end of the printing arm moves to its extreme right position, it makes contact with the latch and causes it to release the print hammer operating bail. The operating bail is swung in a counterclockwise direction by the operating bail spring until it strikes its stop. The print hammer bail, in being driven by the operating bail, is swung toward the type box. When the operating bail is stopped, momentum

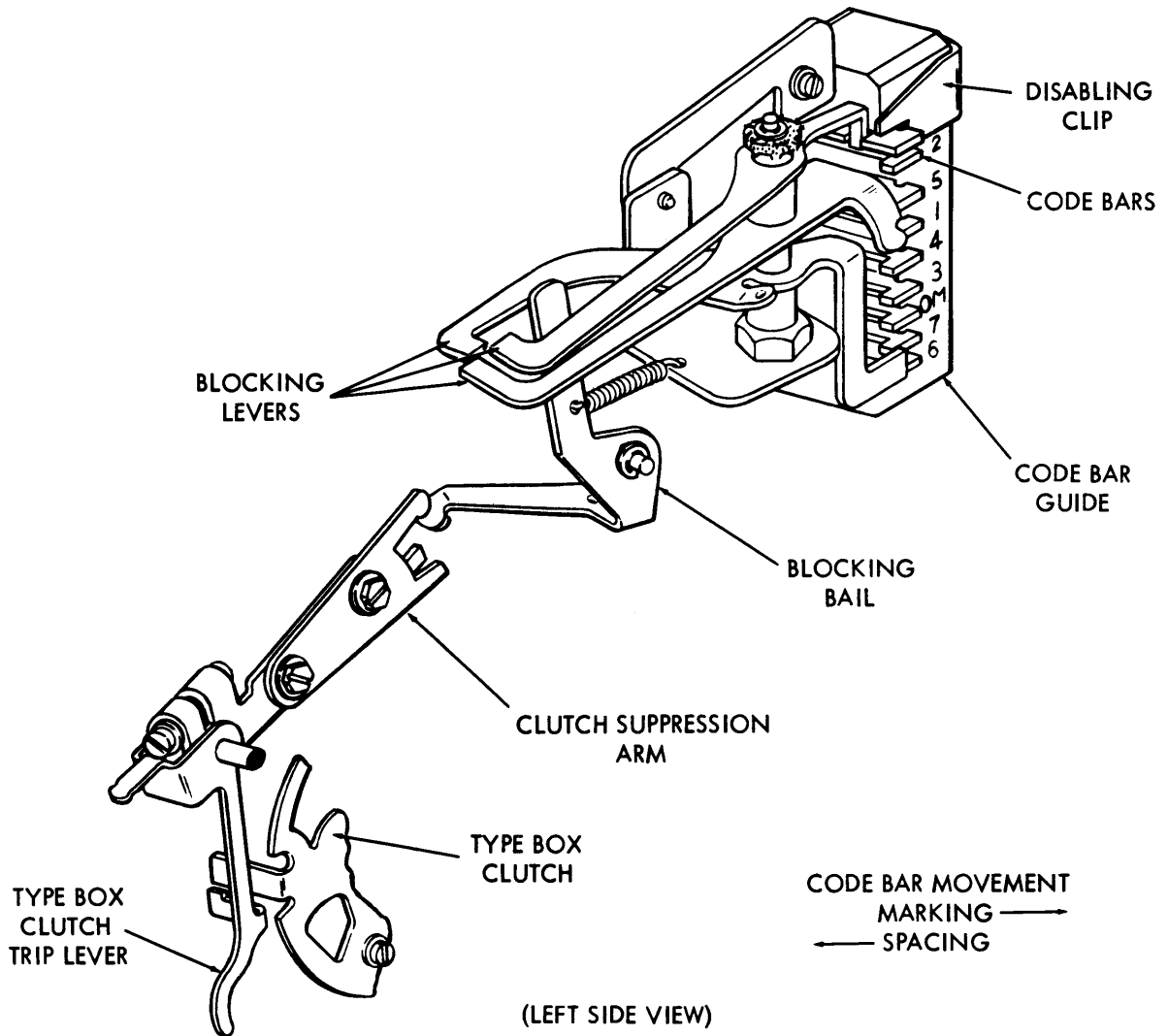

Figure 26 - Print Suppression Mechanism

causes the print hammer bail to continue its travel against the tension of the print hammer bail spring until the printing hammer strikes the selected type pallet. The force with which the hammer strikes is adjustable to three positions marked on the carriage.

D. Print Suppression (Fig. 26)

2.56 A print suppression mechanism designed to prevent printing and spacing on non-printing function code combination signal input is located on the left end of the code bar mechanism and operated by the code bars. Three blocking levers are pivoted by the code bars either to pass or block the blocking bail, which in turn permits operation of the type box clutch trip lever

or blocks its operation through a clutch suppression arm. The effect is to block the trip lever, and suppress printing, when the sixth and seventh code bits are simultaneously spacing, or when the third, fourth, fifth, sixth and seventh code bits are simultaneously marking.

2.57 The front end of the lower blocking lever (Fig. 26) rotates counterclockwise (top view) when the number 6 and number 7 code bars are in spacing position (right). The blocking bail is then blocked by the rear of the blocking lever. When either of these code bars is in marking position (left), the lever is rotated clockwise to free the blocking bail, permitting the clutch suppression arm to rotate when the clutch trip lever is rotated by the trip shaft.

2.58 The front end of the center blocking lever is engaged by notches in the numbers 3, 4, 5, 6, and 7 code bars in such a way that when any are in the spacing position, the lever is rotated counterclockwise to permit free movement of the blocking bail, thus permitting engagement of the type box clutch. When all of these code bars are marking, the blocking lever is rotated clockwise to suppress printing through the blocking bail.

2.59 The upper blocking lever is controlled by the suppression code bar. Since the suppression code bar is retained in spacing position by a disabling clip, the blocking lever is held in counterclockwise position, permitting printing at all times. The suppression code bar, if operated, would be operated from the stunt box.

SPACING MECHANISM

A. General

2.60 To space the printed character properly, the type box and printing carriages must be advanced with each character printed. The spacing must also be accomplished when the input signal code combination represents a letter space. As was shown in Par. 2.40 and Fig. 18, the carriages are connected to a draw wire rope which, in turn, is fastened to the spring drum and the spacing drum. The purpose of the spring drum, which contains a torsion spring, is to tension the draw wire rope, and thus the carriages, to the left. The spacing drum has ratchet teeth about its perimeter which are engaged by the eccentric driven spacing drum feed pawls (Fig. 27). The spacing shaft which mounts the spacing eccentrics is driven through its helical gear attached to the three stop spacing clutch on the main shaft. The gear ratio of 1-1/2 to 1 causes the spacing shaft to turn one-half a revolution each time the spacing clutch is tripped. This allows the feed pawls to advance the spacing drum by one ratchet tooth.

2.61 The same trip shaft which, through a cam on the code bar clutch (Par. 2.10), trips the function clutch also rotates the type box clutch trip lever counterclockwise (viewed from the left). Unless movement of this lever is blocked by the print suppression mechanism, the type box clutch is engaged, oscillating the main rocker shaft, which drives the printing mechanism (Par. 2.47). A cam plate (Fig. 27) fastened to the bottom of the rocker shaft is moved upward by the shaft as it begins its movement.

The cam plate operates the spacing trip lever bail. As this bail is rotated, it raises the spacing trip lever until it latches onto the spacing clutch trip lever arm. As the rocker shaft reverses its direction of rotation, the spacing trip lever bail and the trip lever move downward under spring tension, causing the latched up spacing clutch trip lever arm to operate the spacing clutch trip lever and engage the spacing clutch.

2.62 Before the spacing clutch completes one-third of a revolution, its restoring cam moves the spacing trip lever about its pivot point until it releases the spacing clutch trip lever, which returns to its normal position in time to stop the spacing clutch after one-third of a revolution. The spacing clutch three-stop cam disk upon which the latch lever rides has an indent at each stop position. When one of the three lugs on the clutch shoe lever disk strikes the spacing clutch trip lever, the inertia of the cam disk assembly causes it to turn until its lugs make contact with the lugs on the clutch shoe lever disk. The latch lever drops into an indent in the cam disk, and the clutch is held disengaged until the trip lever is again operated.

B. Spacing Function

2.63 The non-typing function by which spacing between words or any spacing other than that which accompanies printing is accomplished is initiated when the code bars are set in a combination equivalent to the spacing code combination (all spacing except the sixth bit marking). The function is executed through the code bar clutch, tripping the printing clutch, and the spacing clutch as described in Par. 2.60-2.62. For this function, the type box is positioned so that a vacant pallet (top horizontal row, first right row in the figures field) is presented beneath the type hammer. No printing occurs when the type hammer is tripped in its normal fashion. The stunt box is not involved in the execution of this function.

C. Spacing Suppression (Fig. 27)

2.64 When certain non-typing functions are selected or when the carriages reach their extreme right position, it is necessary to suppress spacing to avoid interference with the page printed message or damage to the equipment. This is accomplished by moving the spacing suppression slide forward to a point at which it will hold the upper end of the spacing trip lever forward and prevent it from engaging the spacing clutch trip lever.

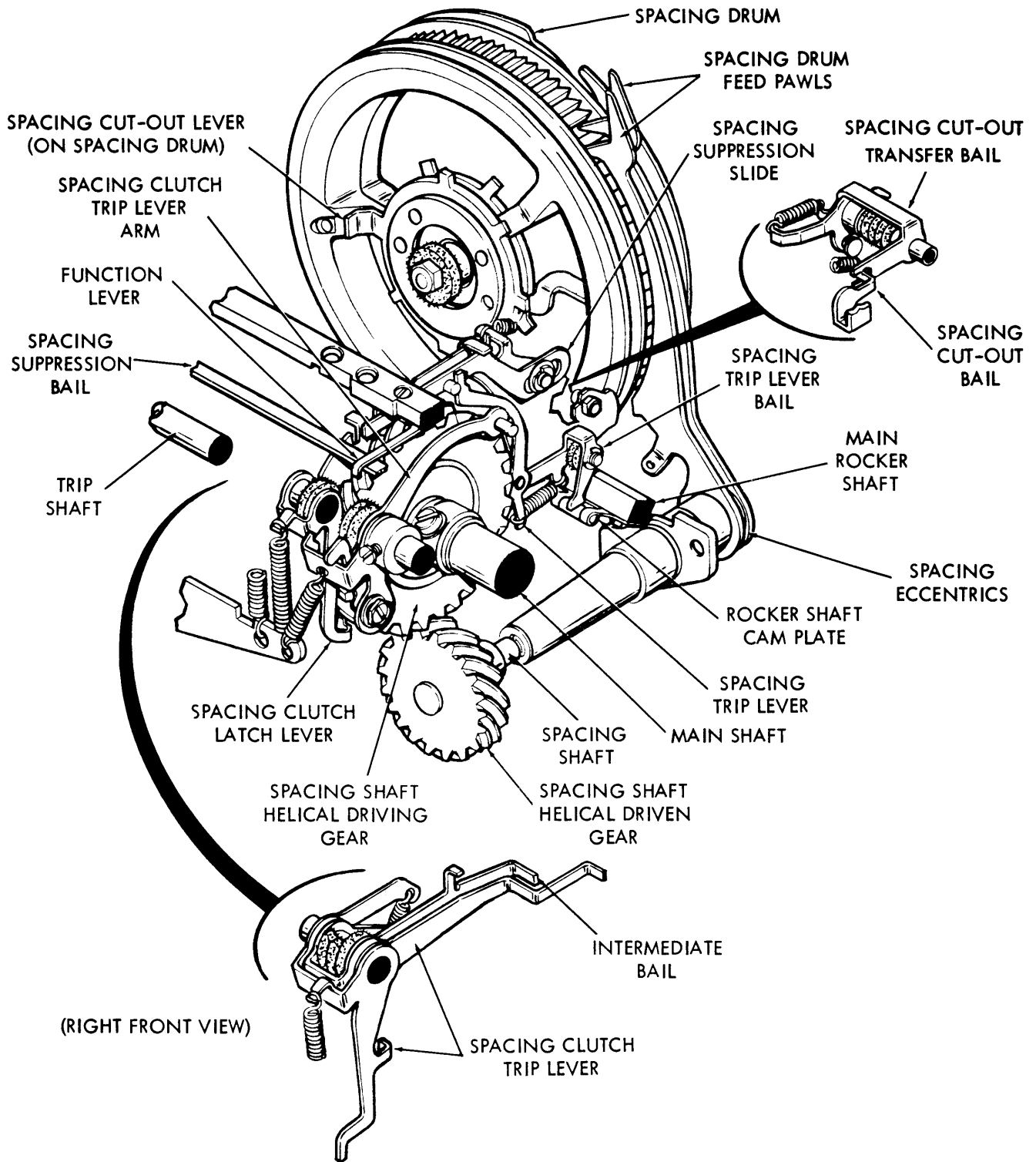

Figure 27 - Spacing Mechanism

2.65 In the case of spacing suppression on selection of a function code combination, the spacing suppression slide is shifted forward by the spacing suppression bail, mounted beneath the function box. When space suppressing function levers are selected, they engage the bail and, when the function mechanism is operated, move the bail forward. Moved forward with the bail, the suppression slide prevents engagement of the spacing clutch.

2.66 When the carriages are near their extreme right position, a cut-out ring on the spacing drum engages the spacing cut-out transfer bail (Fig. 27), which in turn operates the spacing cut-out bail. The ring and the end of the spacing cut-out transfer bail are shown in Fig. 18. The spacing cut-out bail shifts the spacing suppression slide forward and prevents engagement of the spacing clutch until the carriages are returned. The maximum number of characters

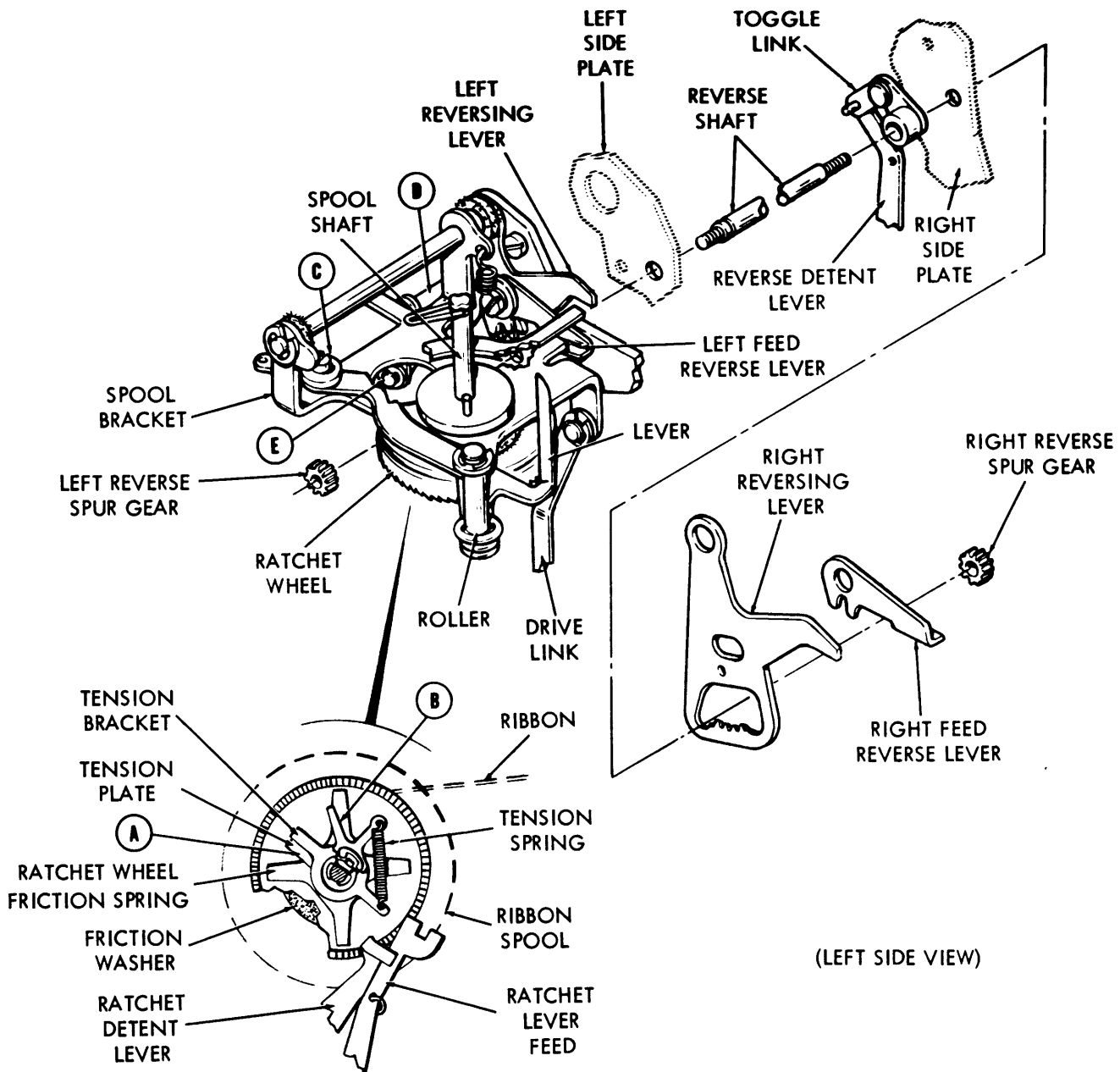

Figure 28 - Ribbon Feed and Reverse Mechanisms

which the typing unit may print is eighty-five, including spacing function spaces. In order to prevent spacing beyond this point with subsequent damage to the equipment, several teeth are omitted from the spacing drum ratchet wheel.

D. Margin Indicator (Fig. 18)

2.67 When used in conjunction with a keyboard base, the typing Unit actuates a margin indicator switch (base mounted). Before the type box carriage reaches the end of its travel, an actuator mounted on the face of the spring drum operates the switch contact. The angular position of the cam disk with respect to the spring drum may be altered to change the point at which the indicator contact will be closed.

RIBBON FEED MECHANISM (Fig. 28)

2.68 The left and right ribbon feed mechanisms oscillate in a vertical plane with each revolution of the type box clutch. They are driven by ribbon drive links attached to the main side levers (Fig. 21). At their uppermost positions, the ribbon mechanisms position the ribbon relative to the horizontal type box row being printed. After each character is printed, the ribbon mechanisms are dropped downward together with and behind the type box, in order that the last character printed may be viewed. The ribbon is held in place at the point of printing by a ribbon guide fastened to the rear of the type box carriage.

2.69 Each of the ribbon mechanisms consists of a bracket which is hinged at its rear end, and upon which is mounted a ribbon spool shaft (Fig. 28). A ribbon tension bracket is keyed to the lower end of the ribbon spool shaft. A ribbon ratchet wheel is mounted freely on the ribbon spool shaft just below the ribbon spool bracket, from which it is separated by a friction washer. This applies a constant drag to the ratchet wheel.

2.70 A ribbon tension plate which is keyed to the hub of the ribbon ratchet wheel has two projecting lugs (A and B, Fig. 28) that straddle the lug on the ribbon tension bracket. A ribbon tension spring tends to maintain the ribbon tension bracket against lug A of the ribbon tension plate. In operation, the ribbon spool bracket, driven by the ribbon drive link, pivots about point C. The ratchet feed and ratchet detent levers pivot about points D and E respectively

and are held against the teeth on the ribbon ratchet wheel by their springs. As the ribbon spool bracket is moved upward, the ratchet wheel feed lever skips over one tooth, while the ratchet detent lever holds the ribbon ratchet wheel from turning backward. When the ribbon spool bracket is moved downward, the ratchet feed lever engages a ratchet tooth and pushes the ratchet wheel. A tooth on the ribbon ratchet wheel then skips over the ratchet detent lever. The teeth on the left and right ribbon ratchet wheels face in opposite directions so that when their feed levers are engaged, the left ribbon ratchet wheel turns counterclockwise (viewed from the top). In order for the ribbon to be pulled from one ribbon spool to the other, only one of the ribbon mechanisms can have its ratchet feed and ratchet detent levers engaged with its ribbon ratchet wheel at a time. As the ribbon ratchet wheel turns, the ribbon tension plate also turns, and extends the ribbon tension spring. When the lug B of the ribbon tension plate makes contact with the ribbon tension bracket, the ribbon spool shaft is made to turn, and the ribbon is wound on the ribbon spool.

2.71 When the ribbon has been completely unwound from one spool, it is necessary to reverse its direction so it can rewind. This is accomplished automatically by disengaging one set of ratchet feed and ratchet detent levers and engaging the other set. While the ribbon is passing from the left spool to the right spool, the right set of levers is engaged. The left set is held disengaged against the tension of the springs by the left ribbon feed reverse lever, which is in its downward position (Fig. 28). The lever is held in this position by means of the ribbon reverse detent lever through the intervening ribbon reverse detent cam, ribbon reverse shaft and ribbon reverse spur gear. As the ribbon unwinds from the ribbon spool, it passes around the ribbon roller and through the slot in the end of the ribbon lever. When the ribbon nears its end of the ribbon spool, an eyelet which is fastened to the ribbon catches in the ribbon lever slot and pulls the lever toward the right. The next time the ribbon mechanism is moved upward, the displaced ribbon lever engages the end of the left ribbon reversing lever and causes it to move to the position shown in phantom in Fig. 28. As the lever moves, its teeth rotate the left spur gear which, through the ribbon reverse shaft, turns the detent cam and the right spur gear. As the right spur gear moves the right ribbon reversing lever downward, a pin on the lever drives the right ribbon feed lever downward to disengage the ratchet feed and wheel. At the

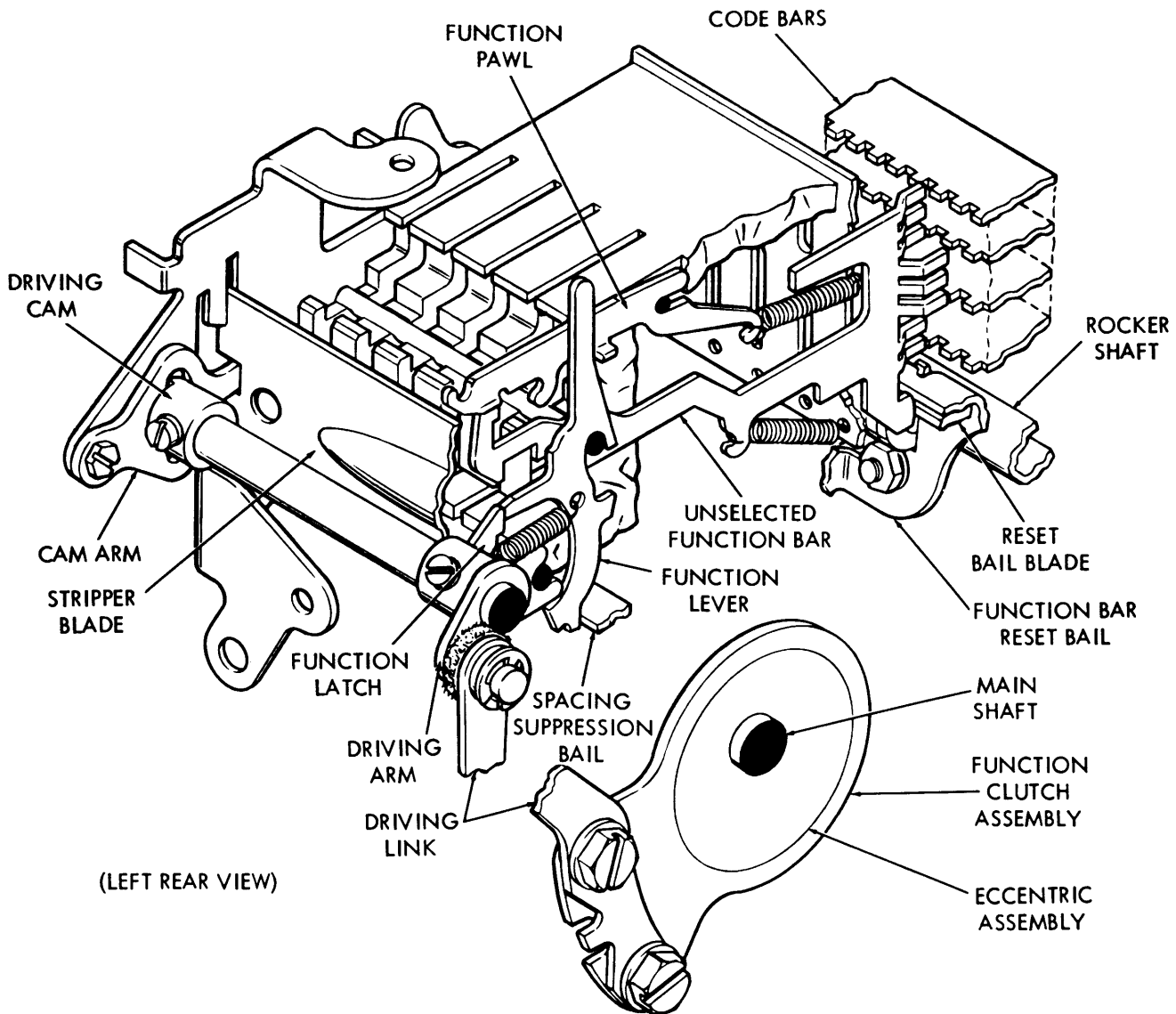

Figure 29 - Stunt Box (Function Linkage Unselected)

same time a pin on the left ribbon reversing lever moves the left ribbon feed reversing lever upward to permit the left ratchet feed and detent levers to engage the left ribbon ratchet wheel. Thus, the ribbon mechanisms are positioned to rewind the ribbon on the left ribbon spool. When it nears its end on the right ribbon spool, the ribbon is again reversed in a manner similar to that just described. During the reversing cycle, the ribbon is maintained taut by the previously extended ribbon tension spring.

FUNCTIONS

A. General

2.72 There are two types of operation which can be performed by the typing unit. The first embodies those mechanical actions which are directly necessary to the actual printing of a character (or space function). The second embodies mechanical action which

alters the positions of the various mechanisms or activates external devices or circuits through switching contacts. The latter are known as functions.

Note: Spacing may technically be considered a function, but it is mechanically associated with the printing operation, except when suppressed by function mechanisms.

2.73 As in printing, the reception of function codes results in the positioning of the code bars (Par. 2.31-2.37). The back edges of the code bars are notched (Fig. 29). Positioned directly behind the code bars is a stunt box, which contains the function bars for the various functions (Fig. 30 and 31). The function bars used on the friction feed typing unit (Fig. 30) are applicable to the sprocket feed typing unit (Fig. 31), with some additional

function bars as shown in the illustrations. Each function bar has a series of tines on its end, offset to one side or the other to correspond with the marking and spacing elements of the particular input signal code combination to which it is to respond. Tines positioned to the right are spacing; those to the left are marking.

2.74 When the function clutch is engaged (Fig. 22), it rotates and extends motion to the function bar reset bail (through the intervening cam and follower arm and function rocker shaft) to cause the function bar reset bail with its attached reset bail blade to release the function bars momentarily (Fig. 32). As the spring tensioned function bars are released, they move forward to bear against the code bars. If the code bars are positioned for a function, each tine on the function bar for that function will be opposite a notch in the code bar. This will permit the selected code bar to continue to move

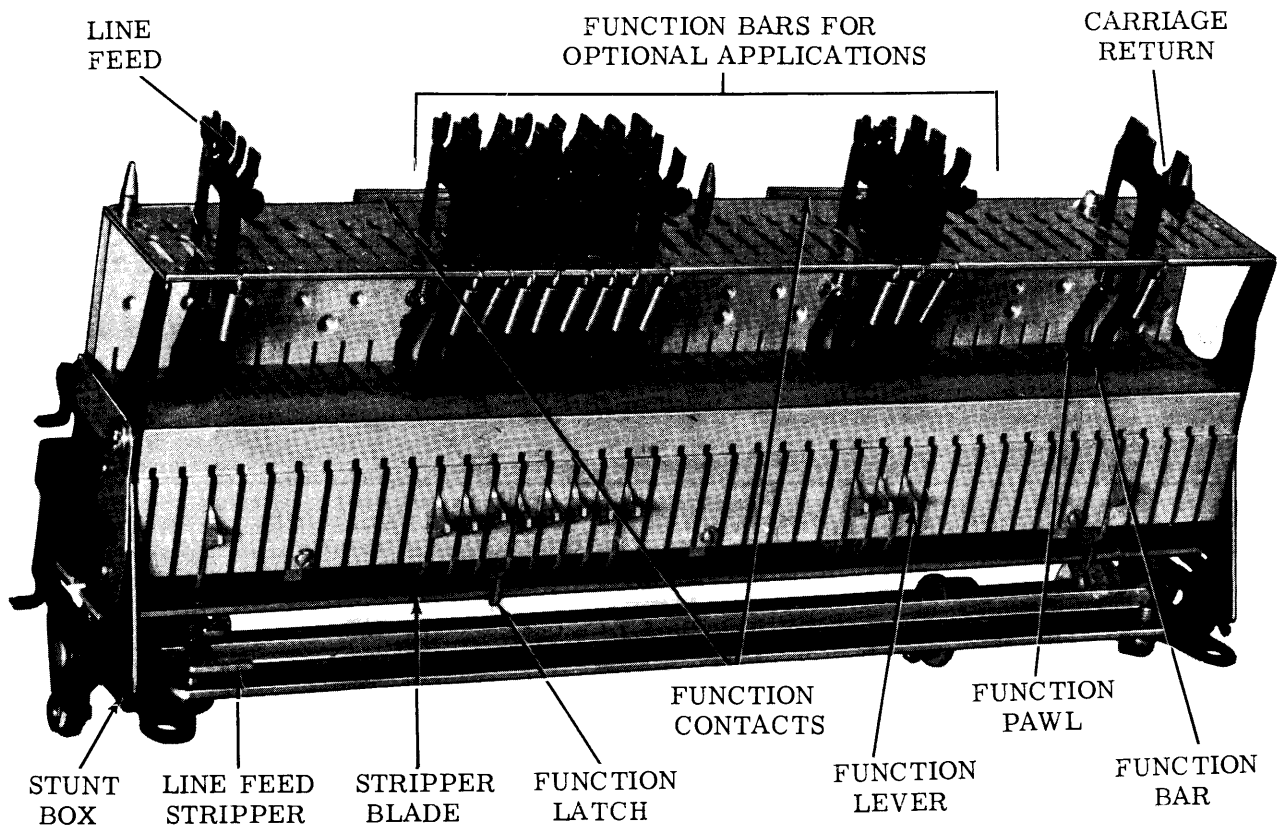

Figure 30 - Typical Stunt Box (Bottom View)

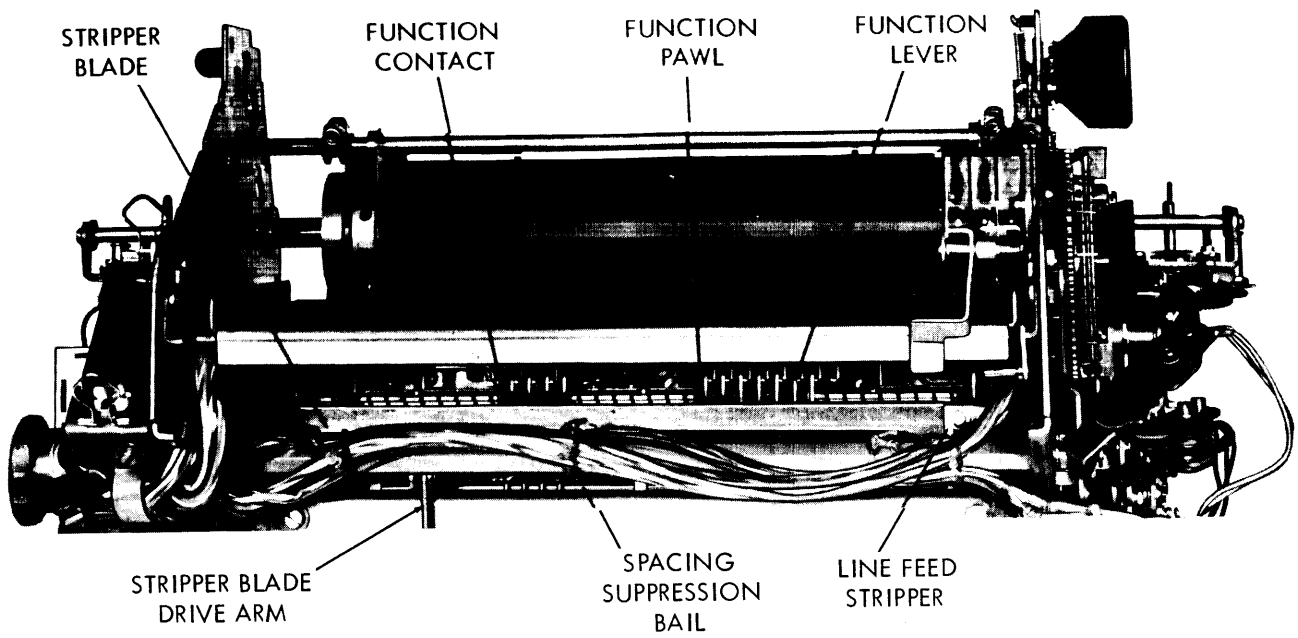

Figure 31 - Stunt Box Installed in Sprocket Feed Typing Unit (Rear View)

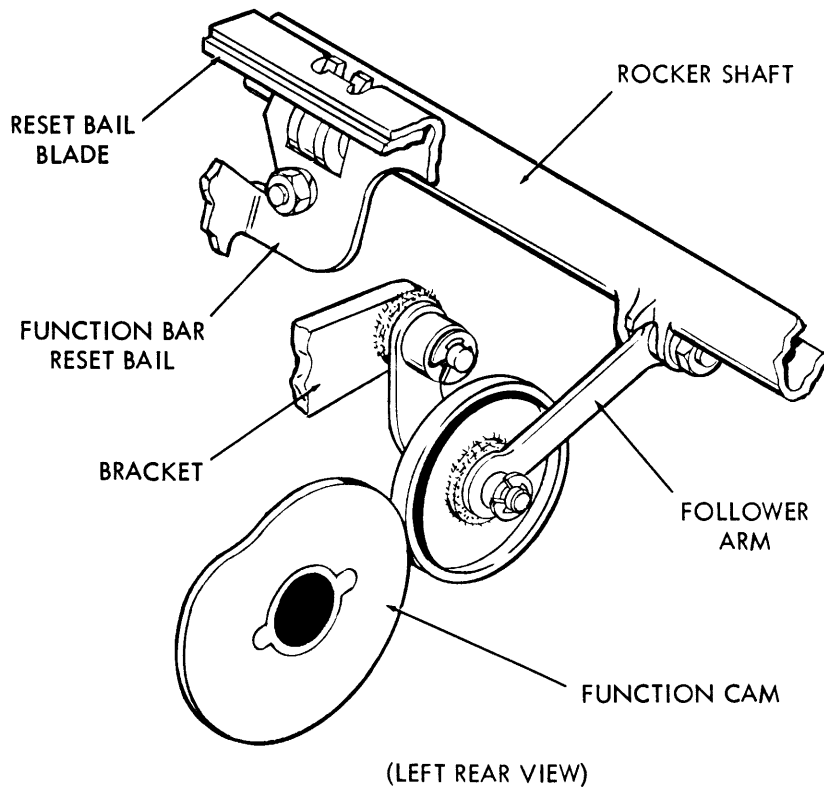

Figure 32 - Reset Bail Mechanism

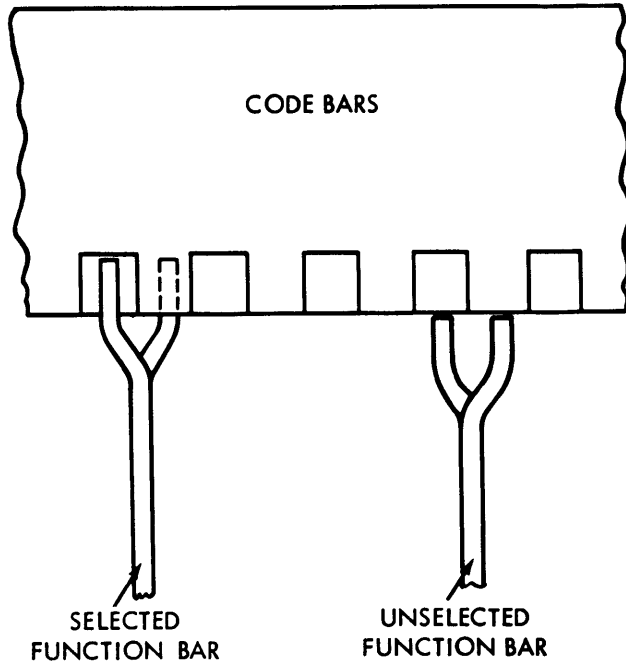

Figure 33 - Function Bar Selection

forward into the code bars, while the other function bars are blocked by one or more code bars (Fig. 33).

2.75 Associated with each function bar in the stunt box is a function pawl and a function lever. In the unselected position, the function bar is not latched with its function pawl

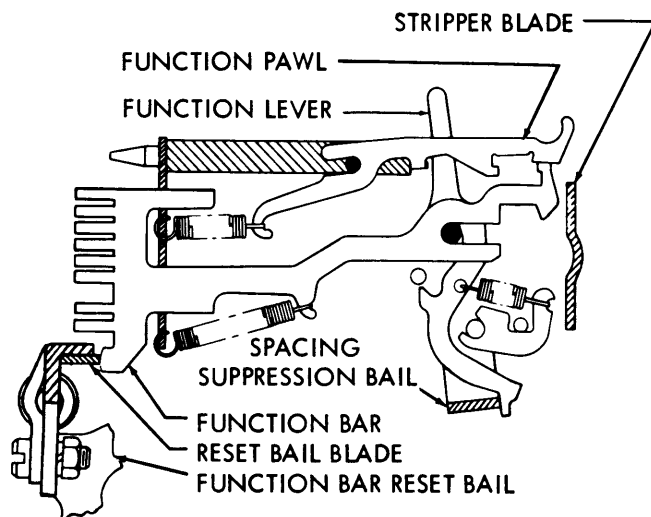

Figure 34 - Typical Function Linkage (Unselected)

(Fig. 34). When the function bar reset bail blade releases the function bars, any selected bar will move sufficiently forward (to the left, in Fig. 34) to permit it to engage its function pawl. Then, as the reset bail blade returns the function bar to its initial position, the function bar carries the function pawl to the rear (to the right, Fig. 35). The function pawl, in turn, moves the function lever clockwise about its pivot point. A projection at the lower end of most function levers operates the spacing suppression bail (Par. 2.65), selected levers moving the bail forward. Either the upper or the lower end operates the indicated function.

2.76 Near the end of the function cycle, a stripper blade (Fig. 36) operated by a cam on the function clutch assembly rises to engage any selected function pawl and strip it from its function bar. Springs return the released function pawl and the function lever to their original position. The function clutch is disengaged upon completion of one revolution when its latch lever falls into the indent of the clutch cam, in the same manner as described in connection with the code bar clutch (Par. 2.36).

B. Carriage Return Function

2.77 The carriage return function mechanism is located in the right end of the typing unit. Reception of the input signal code combination for the function causes the function bar,

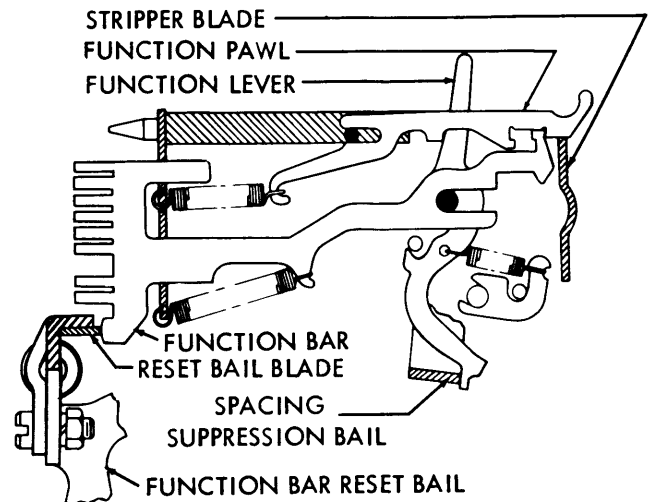

Figure 35 - Typical Function Linkage (Selected)

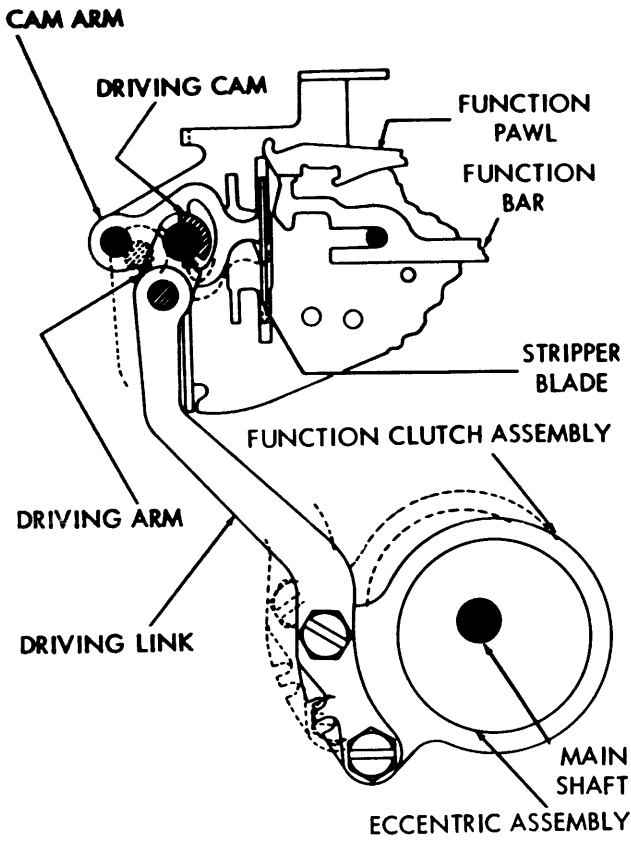

Figure 36 - Stripper Blade Mechanism

pawl and lever to operate (Fig. 37). The lower end of the function lever engages the carriage return slide arm and pushes it forward. The slide arm, in turn, moves the carriage return bail and its lever about their pivot point. As the front portion of the lever moves downward, it takes with it the lower section of the spacing drum feed pawl release link. This causes the upper portion of the link to turn and disengage the spacing drum feed pawls from the spacing drum (Fig. 38).

2.78 When the carriage return lever reaches the lowest point, the carriage return latch bail locks it there. The disengagement of the spacing drum feed pawls from the spacing drum permits the spring drum to return the printing and type box carriages toward the left side of the typing unit. As the spacing drum nears the end of its counterclockwise rotation, the roller on the stop arm contacts the transfer slide which, in turn, drives the dashpot piston into the dashpot cylinder. A small passageway

with an inlet from the inside of the cylinder and three outlets to the outside is incorporated in the end of the cylinder. Two of the openings to the outside are closed by a steel ball, which is held in its seat by means of a compression spring. A set screw which may be locked in place with a nut is used to regulate the spring pressure on the ball. The rate of deceleration provided by the cushioning effect of the trapped air is automatically regulated for various lengths of lines by means of the ball valve. This, together with the direct opening to the outside, determines the rate at which the air may escape from the cylinder. When the spacing drum reaches its extreme counterclockwise position, an extension on the stop arm trips the carriage return latch bail plate, which is fastened to the carriage return latch bail. The latch bail disengages the carriage return lever, and the feed pawls are again permitted to engage the spacing drum.

2.79 Local (off-line) operation of the carriage return mechanism may be obtained from the keyboard base or base on which the typing unit is mounted. A projection beneath the carriage return lever (Fig. 37), when rotated to the rear (counterclockwise, viewed from the right), operates the carriage return mechanism in the same way as when this lever is operated by the stunt box.

C. Line Feed Function

2.80 The line feed function mechanism is located in the left end of the typing unit. The code bar mechanism set to correspond to an input signal code combination for spacing permits two line feed function bars, pawls and levers to operate. The function linkage at the far left of the stunt box (third from the left on sprocket feed typing units equipped for vertical tabulation) operates the line feed mechanism (Fig. 39). The function bar positioned in slot 29 of the stunt box is used, in connection with line feed, only for space suppression (Par. 2.83). The lower end of the line feed function lever engages the line feed slide arm and pushes it forward. The slide arm, in turn, moves the line feed clutch trip arm and the trip lever above their pivot point until the trip lever releases the three stop line feed clutch. The line feed gearing is such that each one-third revolution of the clutch will advance the platen by one line. Therefore, the length of time that the line feed clutch trip lever is held away from the clutch will determine the number of line feeds that occur.

2.81 The timing relationship between the stripper blade cycle and the main shaft rotation is such that the function pawl is not stripped from a function bar until after more than one-third of a revolution of the clutch has occurred. Thus, the line feed clutch trip lever will stop the clutch after two-thirds of a revolution, or double line feed, has occurred. When single line feed is desired, it is necessary to strip the function pawl from the line feed function bar before the

line feed clutch completes one-third of a revolution. This is accomplished by the use of an auxiliary function pawl stripper which is attached to the left end of the stripper bail. The cam disk on the three stop line feed clutch provides the motive force to operate the stripper bail once each one-third revolution of the line feed clutch.

2.82 The stripper bail on which the slotted line feed function pawl stripper rides may

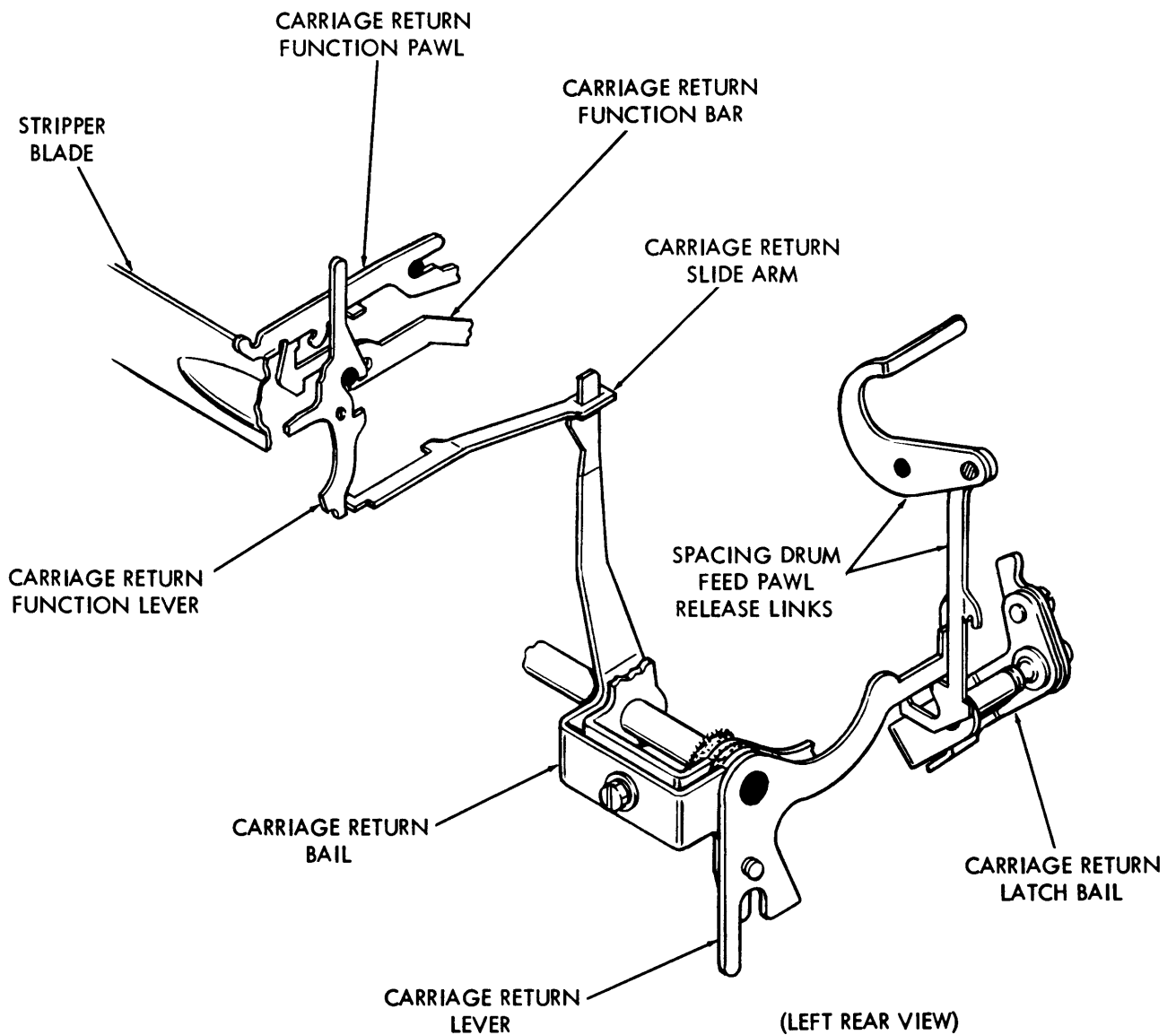

Figure 37 - Carriage Return Function Mechanism

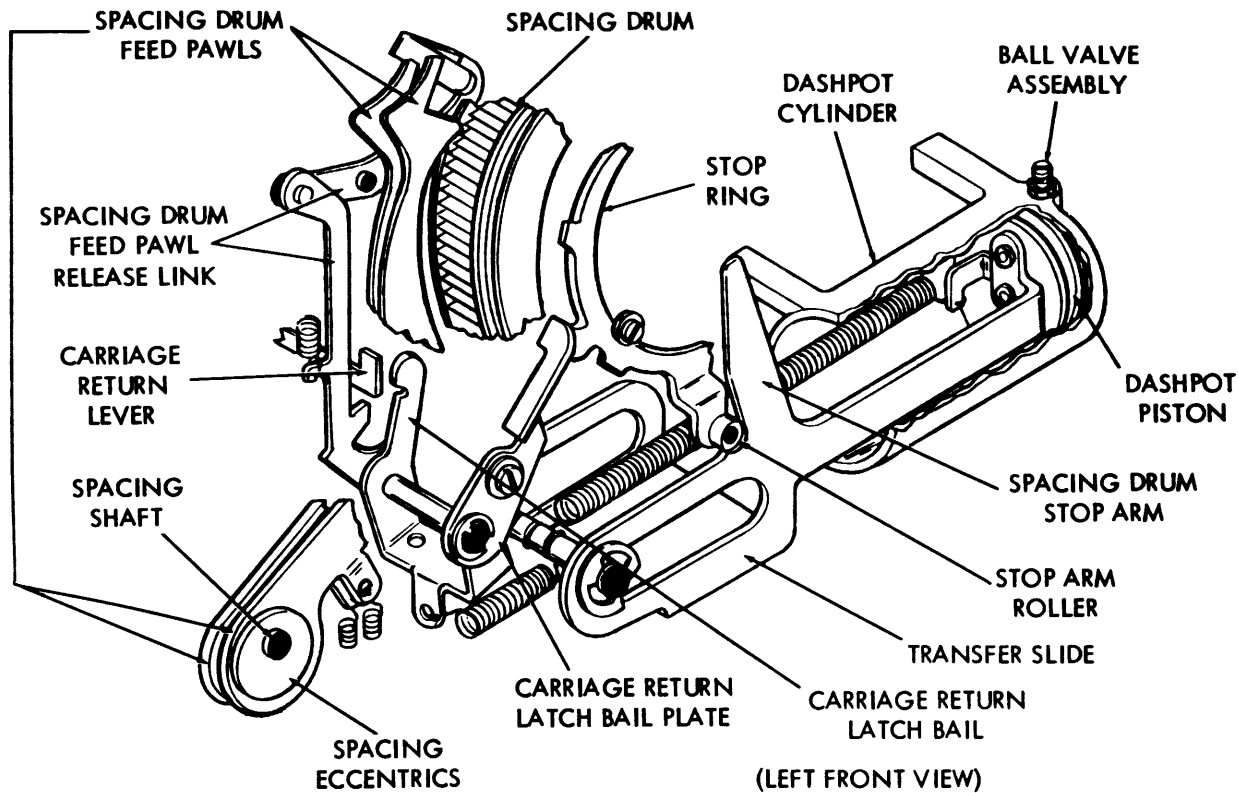

Figure 38 - Carriage Return Mechanism

be shifted toward the right (double) or to the left (single) by action of the single or double line feed lever (Fig. 40). The upper end of the pivoted single or double line feed lever protrudes from the upper left of the left side plate of the typing unit, where it rides in the two position side frame detent extension. When the lever is in position 1, the stripper bail engages line feed function stripper to raise it into contact with the function pawl before the stripper blade would strike it. When the lever is moved to the rear (position 2), the bail is disengaged from the blade, and the stripper blade strikes the function pawl in the normal cycling of the function box stripper blade.

Note: On Typing Units equipped for vertical tabulation and form out, the operating principle of the stripper mechanism in single line feed operation is as described here. The line feed function pawl stripper, however, is of a different design to accommodate the additional form out and vertical tabulation functions.

2.83 When single line feed is being used, the line feed function lever is released too soon (by the line feed function pawl stripper) to prevent spacing. Therefore, an additional line feed function bar, pawl and lever are installed in slot 29 of the stunt box for the purpose of suppressing spacing on single line feed function. This mechanism, which always operates on the line feed function code bar arrangement, is released only by the stunt box stripper blade and, therefore, holds the spacing suppression bail operated (forward) until the spacing cycle is completed. After the line feed clutch is stopped by its trip lever, it is disengaged when the latch lever drops into the indent in the clutch cam, in the same manner as described in connection with the code bar clutch (Par. 2-36).

2.84 Each one-third revolution of the line feed clutch causes its attached spur gear (Fig. 40) to rotate the line feed eccentric spur gear and its attached eccentrics one-half of a revolution. The eccentrics, which are offset in opposite directions, each carry a line feed bar. These bars are guided by the line feed bar bell crank

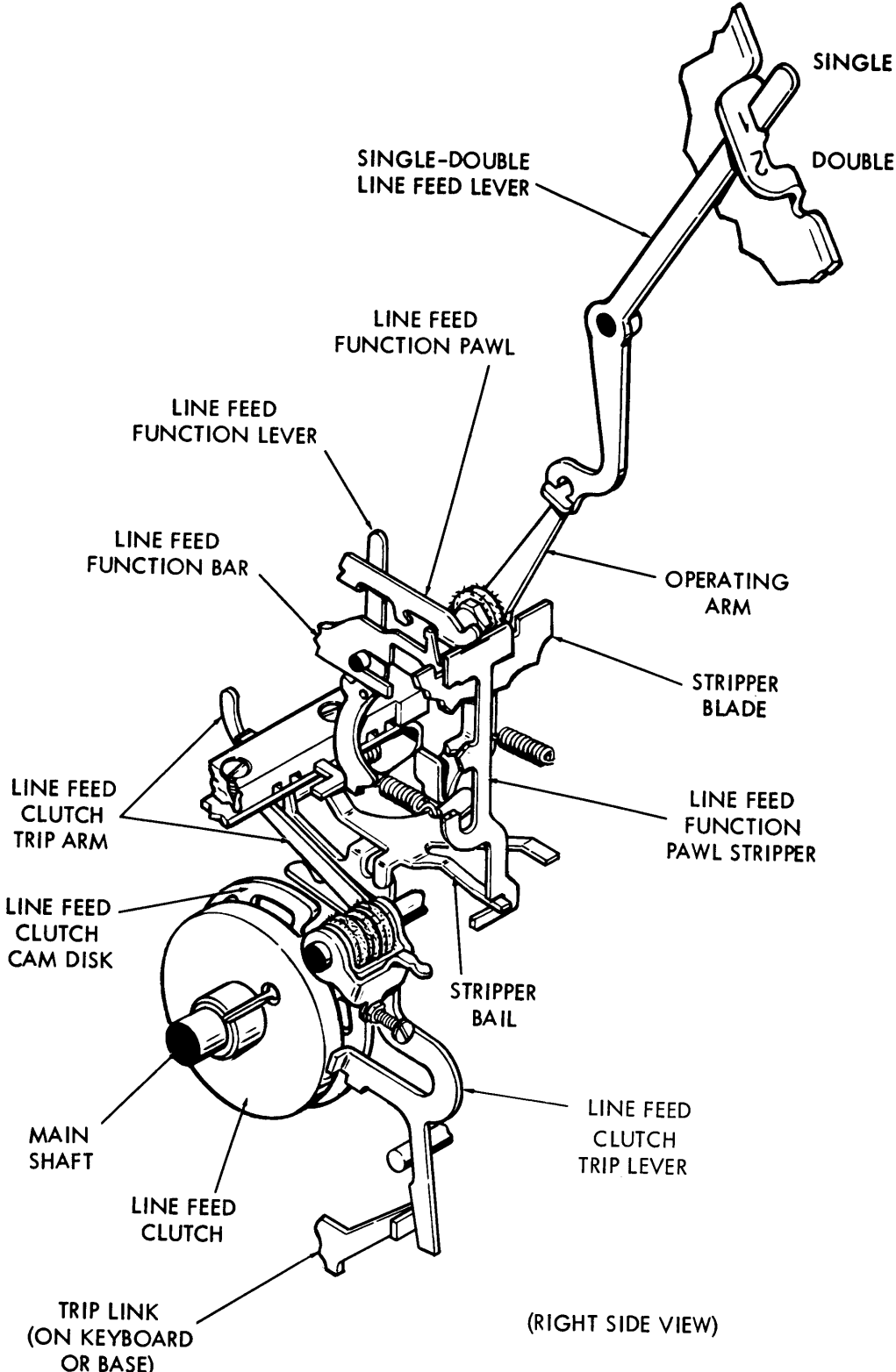

Figure 39 - Line Feed Mechanism

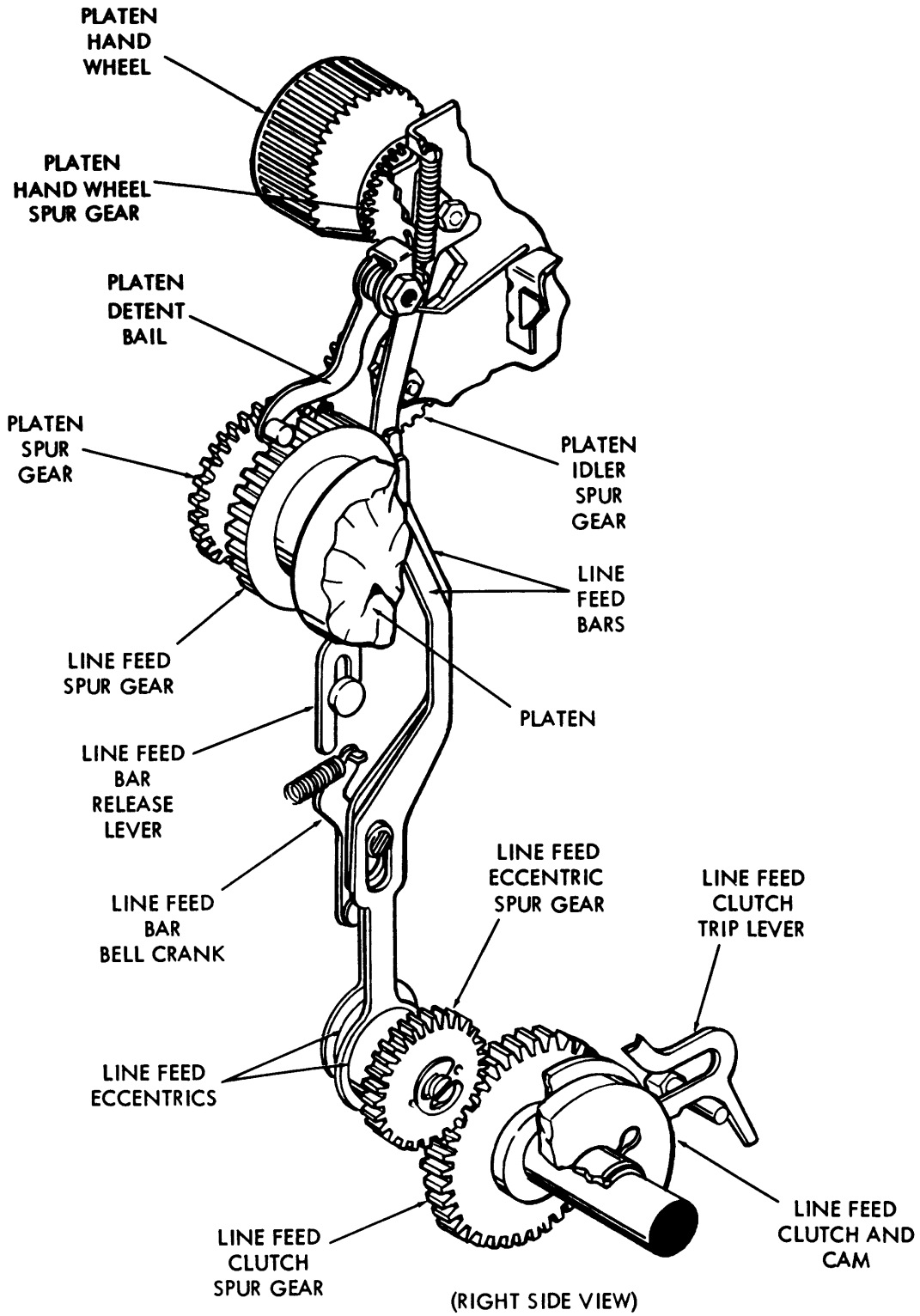

Figure 40 - Single-Double Line Feed Lever

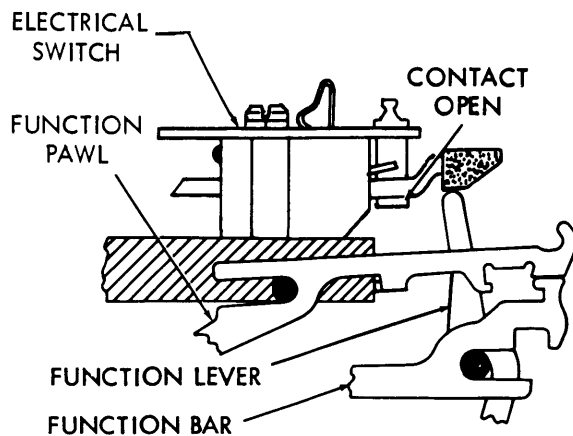

Figure 41 - Typical Box Contact (Unselected)

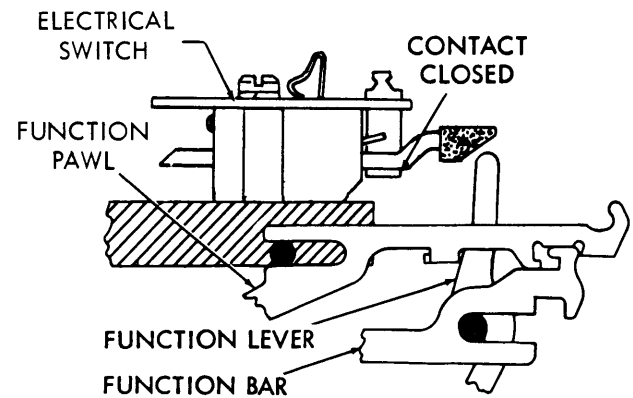

Figure 42 - Typical Box Contact (Selected)

and alternately engage the line feed spur gear on the platen, advancing the platen one line for each one-half turn of the eccentrics. A platen detent bail engages the line feed spur gear to retain the platen at each setting.

2.85 When it is desired to position the platen manually, this may be accomplished by bearing down on and rotating the platen handwheel at the top of the right side plate. This causes the platen handwheel spur gear to engage the platen idler gear, which in turn is engaged with the platen spur gear on the platen shaft. At the same time, the line feed bar release lever (Fig. 40) bears on the line feed bar bell crank and causes it to disengage the line feed bars from the line feed spur gear.

2.86 Local (off-line) operation of the line feed mechanism may be obtained from the keyboard base or base on which the typing unit is mounted. A projection beneath the line feed clutch trip lever (Fig. 39), when rotated to the rear (counterclockwise, viewed from the right), operates the line feed mechanism in the same way as when this lever is operated by the function box. Since the clutch is manually engaged, line feed is continuous until released at the keyboard or base.

D. Stunt Box Contacts (Fig. 41 and 42)

2.87 For external circuit control and switching functions, the function levers may be positioned to operate normally open, normally closed, or SPDT switches mounted on the top of

the stunt box. In general, the function contacts are similar except for electrical connections, which are determined by external requirements. The contact arm configuration is changed as required to either make or break the contact when the associated function lever is in selected (rear) position. All contacts are wired through the cable connector located on the right side plate. A typical contact (NO) is illustrated in unselected (Fig. 41) and selected (Fig. 42) condition.

2.88 The contact operated by the function linkage in slot 14 of the stunt box operates in response to an input signal code combination representing R1 OFF (Receiver Off). This is a normally closed contact.

2.89 The contacts operated by the function linkages in slots 15, 16, 27, 28, 30 and 32 of the stunt box are normally open contacts. They operate in response to the following input signal code combinations (from right to left on the stunt box) in sets operating in switched network service.

15	R1 ON	Receiver On
16	BELL	Signal Bell
27	EOT	End of Transmission
28	X-ON	Transmitter On
30	ACK	Acknowledge
32	RU	Are You

2.90 The contacts operated by the function linkages in slots 25 and 26 (in sets operating in switched network service) both operate in response to an input signal code combination representing WRU (Who Are You). The

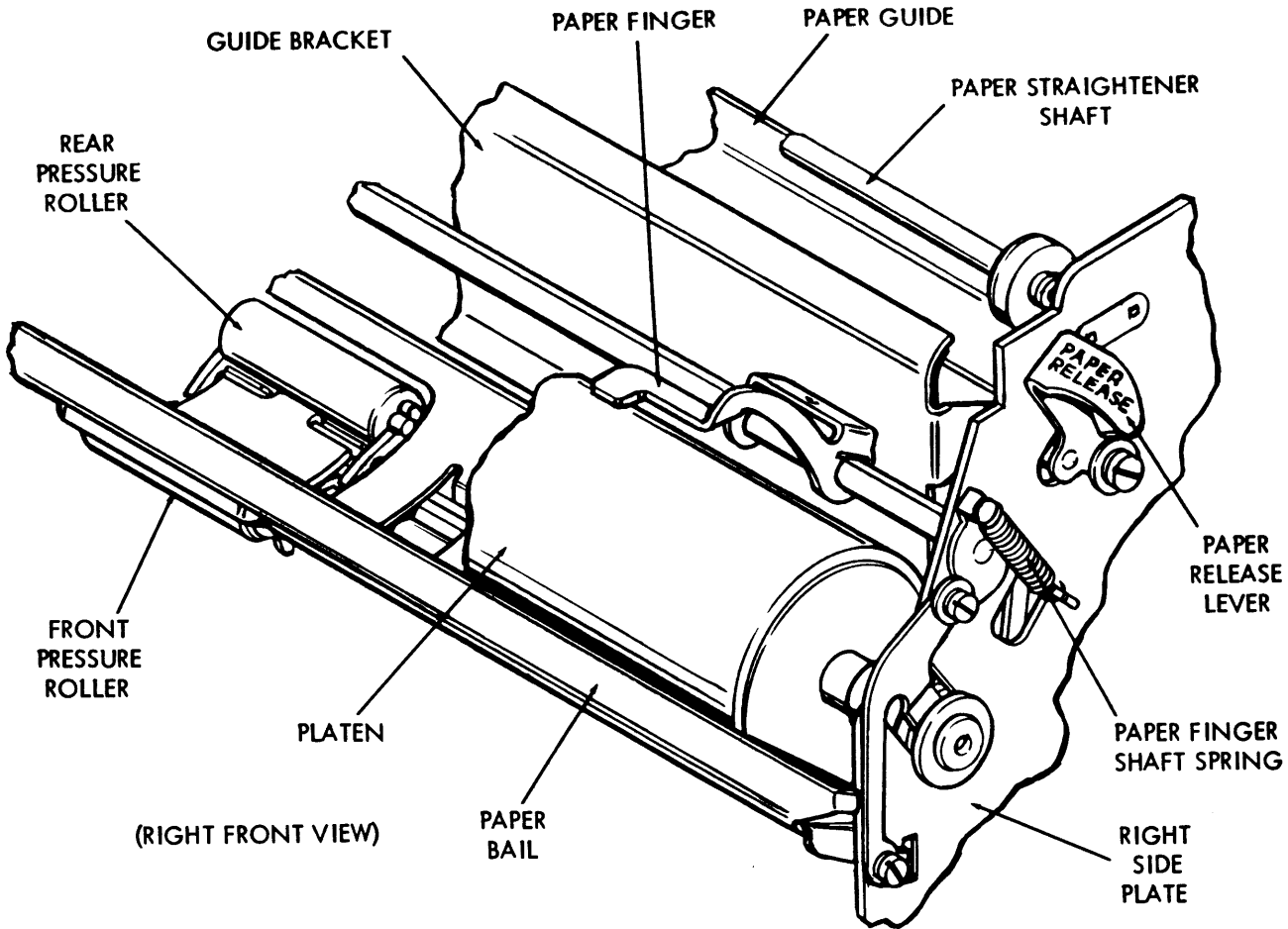

Figure 43 - Friction Feed Platen Mechanism

contact operated by the function linkage in slot 31 operates on X-OFF (Transmitter Off) code. These switches are all SPDT contacts.

2.91 When the ACK code is received (by sets operating in switched network service) the function linkage in slot 30 of the stunt box is operated. This linkage also engages the adjoining line feed function bar linkage in slot 29 when it pushes rearward on an ear of the line feed function lever. The line feed function lever ear latches the ACK function bar, and the contact operated is held closed until it is released when a line feed input signal code combination is received.

3. FRICTION FEED TYPING UNIT

GENERAL DESCRIPTION

3.01 The friction feed typing unit includes all features of the basic printer described

in Par. 1 and 2 of this section. In addition, it has a friction feed paper mechanism.

PRINCIPLES OF OPERATION

3.02 The operation of the friction feed typing unit is as described in Par. 2 of this section. In addition, the equipment has a friction feed paper mechanism.

3.03 Paper for the page printed message is stored on a roll 8-1/2 inches wide, mounted on a paper spindle suspended between the two side plates at the rear of the typing unit. From the roll, the paper passes over a paper straightener shaft, downward behind the platen (Fig. 43) and between the platen and three pressure rollers. A paper pressure bail at the front of the platen equalizes pressure brought to bear on the paper by the pressure rollers. The

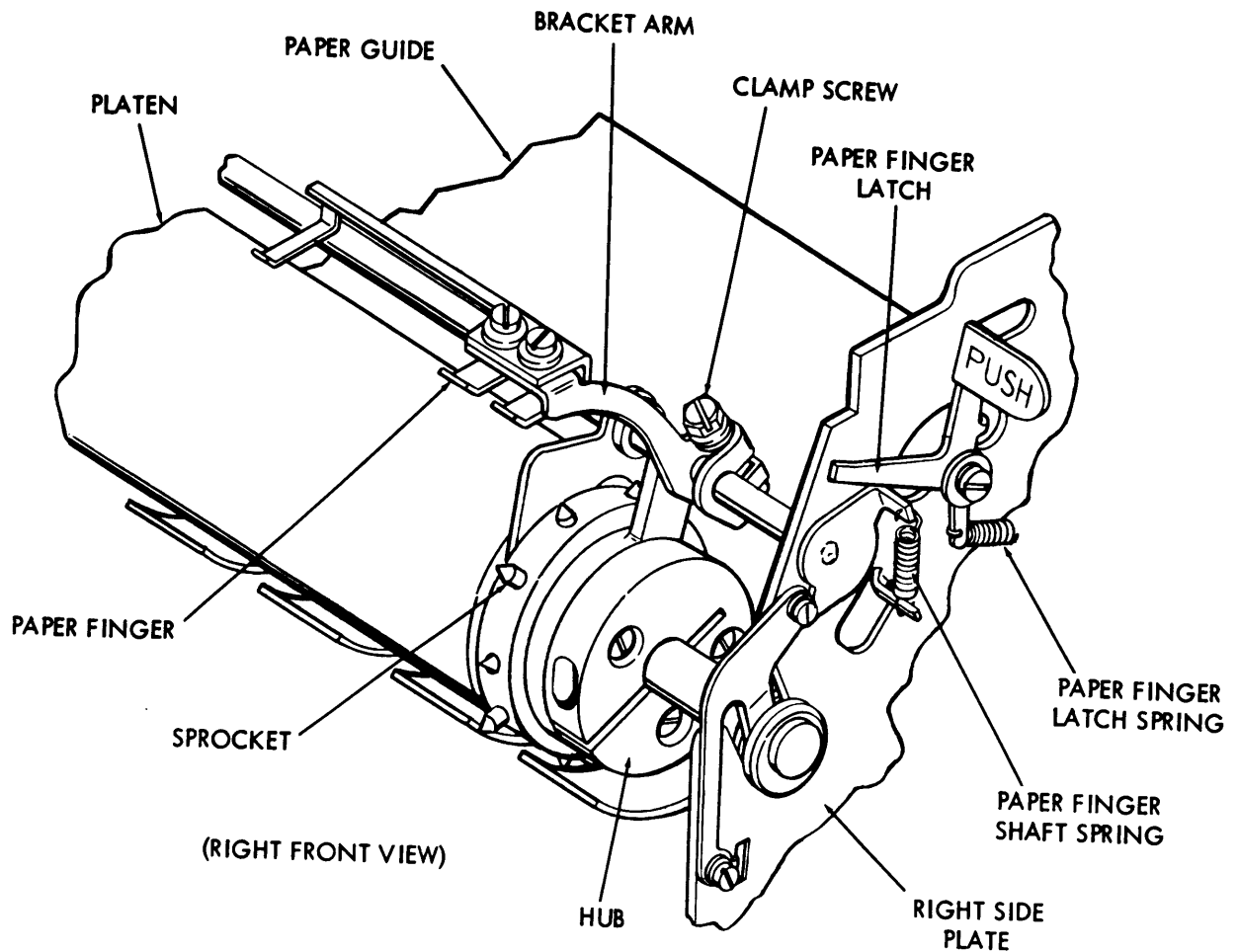

Figure 44 - Sprocket Feed Platen Mechanism

pressure bail can be released by rotating the paper release lever at the top of the right side plate to the rear (clockwise, viewed from the right) when it is necessary to straighten the paper or to remove paper from the platen. Two paper fingers operated on a spring tensioned shaft across the front of the platen hold copy paper firmly against the platen, in position for printing.

4. SPROCKET FEED TYPING UNIT

GENERAL DESCRIPTION

4.01 The sprocket feed typing unit includes all features of the basic printer described in Par. 1 and 2 of this section. In addition, it has a sprocket feed mechanism for insertion of a form fold paper supply for the page printed message.

PRINCIPLES OF OPERATION

4.02 The operation of the sprocket feed typing unit is as described in Par. 2 of this section. In addition, the equipment has a sprocketed form fold feeding platen.

4.03 The platen is equipped at each end with an eleven pin sprocket, with pins spaced to accommodate holes along the edges of form fold paper for the page printed message (Fig. 44). The spring loaded pins are cammed (within the platen) so that the two bottom and two top pins on each side at the front of the platen are extended, while all others are retracted. Extended pins engage the holes in the form fold and pull the paper into page printing position over the front of the platen, where it is held by two paper fingers. At the rear of the platen, the form fold is fed through an aperture at the back of the

cabinet housing the typing unit, across a flat paper guide, and under the bottom of the platen. Paper feeding and line feeding are as described for the basic printer (Par. 2.80-2.85). Paper fingers are released to a spring loaded upright position by pushing a lever marked "PUSH" on the top of the right side plate to the rear. The fingers are repositioned by depressing them manually until the end of the paper guide shaft latches an indent on the release lever.

5. VARIABLE FEATURES

PAPER OUT CONTACTS (Fig. 45)

5.01 A bell crank follower lever is positioned to be held by spring tension against the bottom side of the paper supply roll. When a little less than 1/4 inch remains on the paper supply roll, the bell crank operates the lower of two microswitches, to close a normally open circuit and energize an external warning device. If the paper roll is not replaced, as more paper is used, the bell crank follower is rotated farther

until the upper switch is operated. This SPDT contact interrupts operation of the typing unit and indicates a busy line condition to other stations on the signal line.

FORM OUT AND PAPER JAM CONTACTS

5.02 Three switches mounted on the inside of the left side plate, above the paper guide, are operated by a low paper and paper jam lever and an end-of-form lever (Fig. 46), both of which ride above the feeding form. The low paper lever, first to operate, energizes an external warning signal through the left switch when paper is low or through the center switch when there is a jam in the form feeding mechanism. The form out switch operates through the right switch to terminate printing operations and signal the equipment as busy to prevent further message reception.

HORIZONTAL TABULATION

5.03 The spacing drum for typing units equipped for horizontal tabulation has a slotted

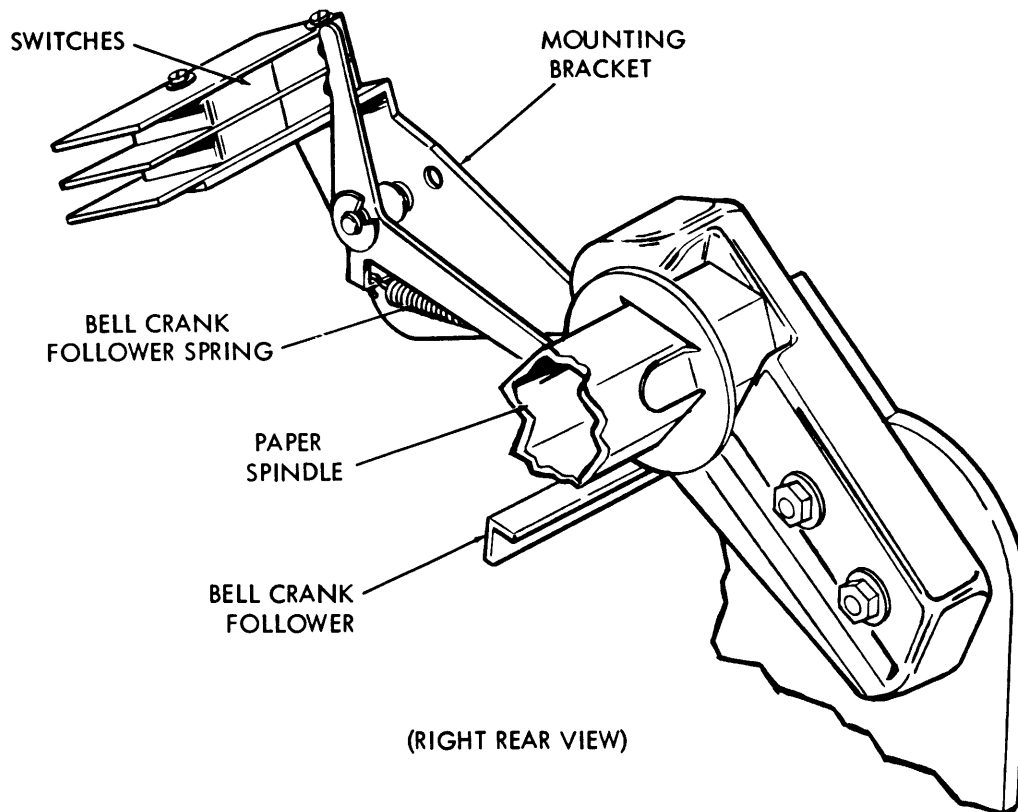

Figure 45 - Paper Out Contacts (Friction Feed)

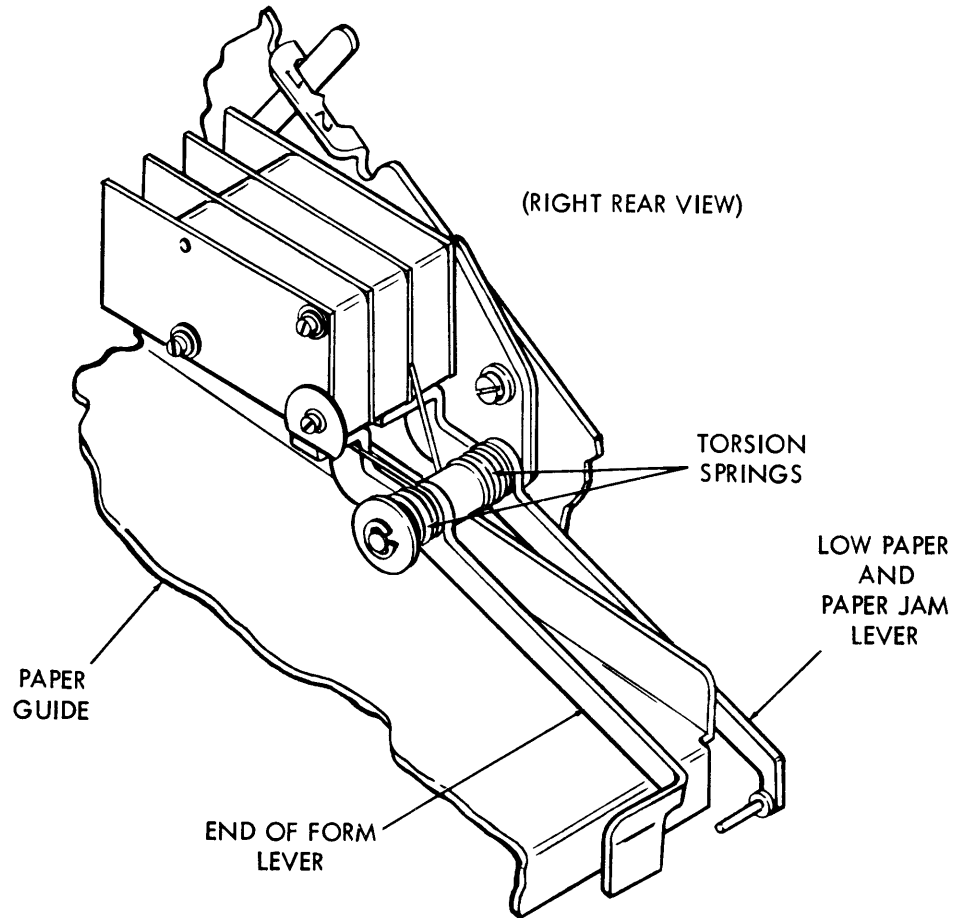

Figure 46 - Form Out and Paper Jam Contacts (Sprocket Feed)

tab stop ring mounted over the face of the spacing drum, in place of the carriage return ring on the basic printer. The ring (Fig. 47), when coded for the desired tabulation, will allow the carriage to be moved rapidly, at a speed threetimes that of normal spacing, to predetermined horizontal positions on the printed page.

5.04 Reception of the input signal code combination representing horizontal tabulation operates the associated stunt box mechanisms to move the function lever forward. The function lever moves the horizontal tabulator slide (Fig. 48) forward. As the slide arm moves forward, it engages the operating lever cam plate, causing the operating lever to pivot about its mounting stud, located at the center of the lever. As the upper end of the operating lever moves forward, the extension link attached to the lower end of the lever moves to the rear. Near the end of its travel, the extension link clears the blocking lever, allowing it to move down

into position to block the link from moving forward.

5.05 Tripping the spacing clutch is initiated in the same way as for normal printing (Par. 2.60-2.62). As the trip lever moves down, however, it hooks over and pulls down the intermediate trip bail (Fig. 47). The intermediate bail in turn pulls down the stop lever arm and trips the clutch stop lever, which is clamped to the lower end of the stop arm. The spacing clutch then starts to rotate. The stop lever arm in its unoperated position rests against the intermediate bail.

5.06 Fastened to and moving as part of the operating lever is the latch bail adjusting plate (Fig. 48). Mounted to the stud on the upper end of the adjusting plate is the stop lever arm latch bail. The latch bail in its rest position is held forward by spring tension against a projection on the adjusting plate. Therefore, when the upper

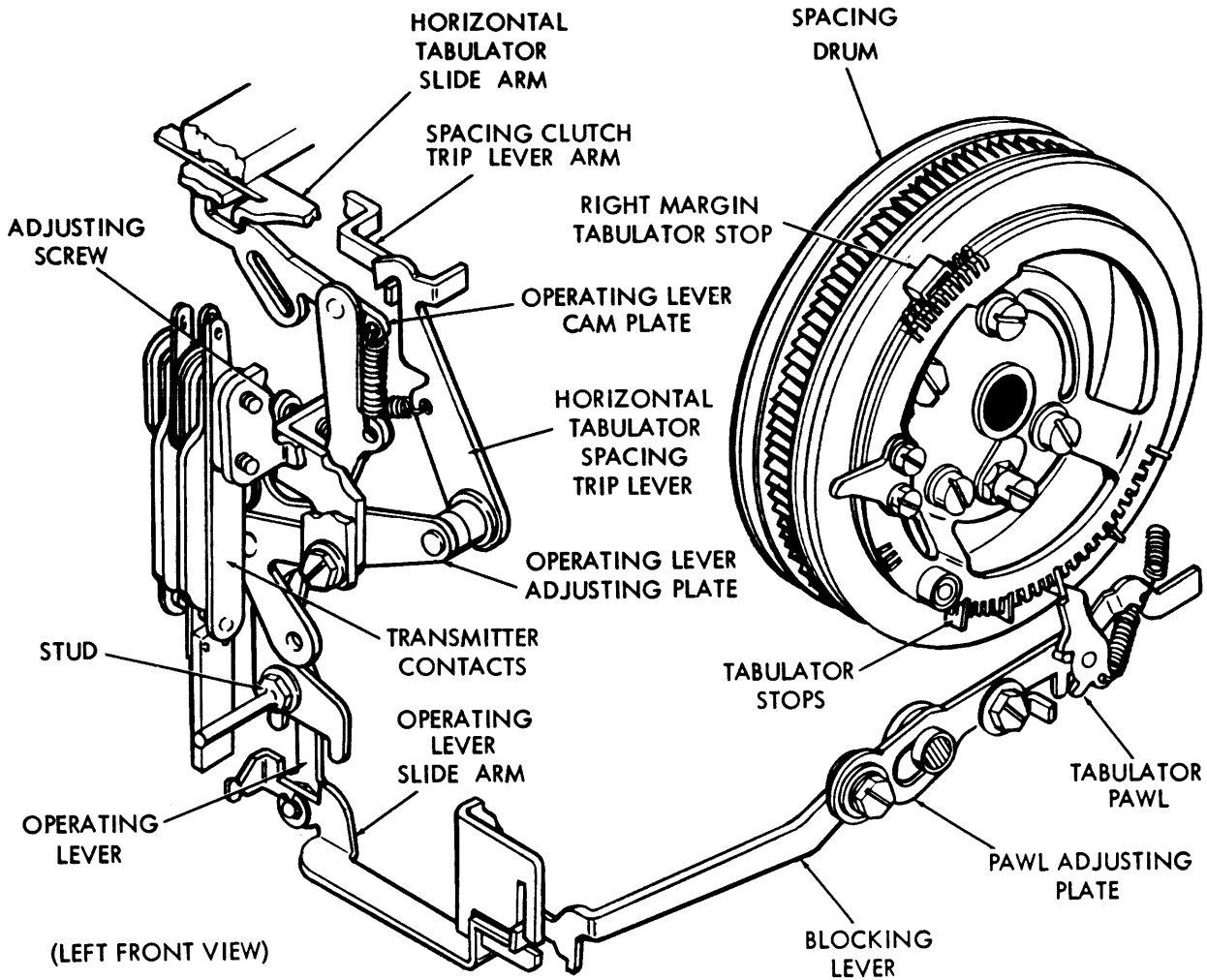

Figure 47 - Horizontal Tabulation Mechanism

end of the operating lever moves forward, the latch bail moves with it until the upper end of the latch bail strikes the spacing stop lever arm, which would not have been pulled down yet. The operating lever continues moving until it reaches its forward position, but the latch bail resting against the stop lever arm is prevented from going any farther and pivots around its mounting stud. Later, when the stop lever arm is pulled down by the spacing trip lever, the forward end of the stop lever arm comes below the latching surface of the latch bail. The latch bail then moves forward over the stop lever arm, latching it down as long as the operating lever is held in its operated position.

5.07 As the spacing clutch starts to rotate, the cam plate stripper bail (Fig. 48) engages

the cam lobe on the spacing clutch restoring cam. This pivots the stripper bail about its shaft, causing the operating lever cam plate to be pivoted downward, out of engagement with the slide arm. The operating lever then drops back slightly until the lever extension link butts up against the blocking lever, which is in the down position. Thus, the operating lever is held operated, the spacing stop lever arm is latched down by the latch bail, and the spacing clutch will rotate until the blocking lever is tripped, unblocking the operating lever extension link.

5.08 As the spacing clutch rotates, the spacing drum will rotate until a tab stop attached to the drum reaches the tabulator pawl mounted on the blocking lever (Fig. 47). As the tab stop moves across the pawl, the pawl is moved down,

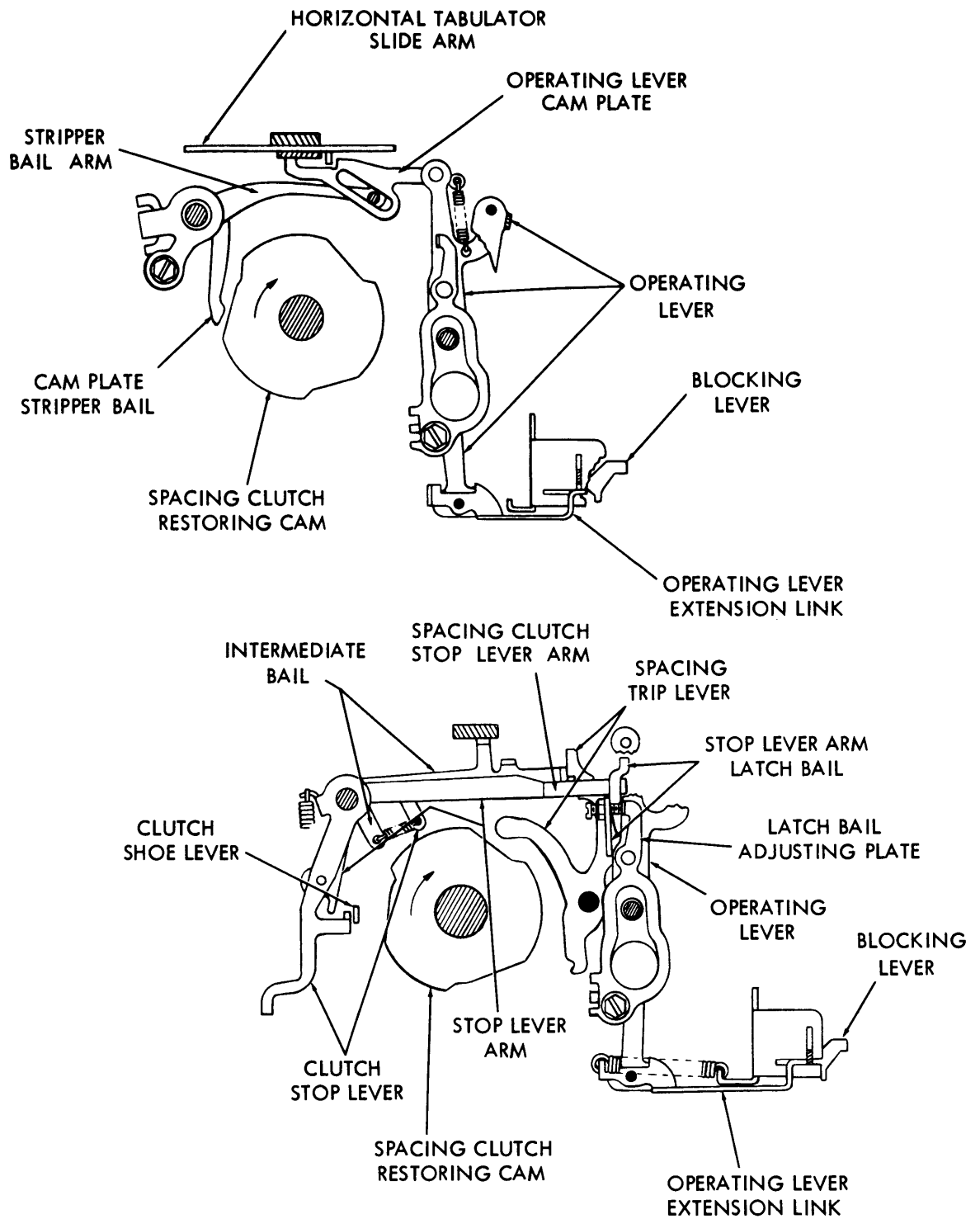

Figure 48 - Horizontal Tabulation

causing the blocking lever to rotate about its mounting stud and releasing the operating lever extension link. The operating lever returns to its unoperated position. The latch bail releases the stop lever arm, and the clutch stop lever blocks further rotation of the spacing clutch. The tabulator function slide arm returns to its unoperated (rear) position when the function pawl is

stripped from the function bar during the normal operation of the function stripper blade.

5.09 When the printing carriage nears the right margin position, the spacing cut-out lever (Fig. 27) on the spacing drum engages the lower surface of the bail extension pawl. The extension pawl and bail rotate together due to

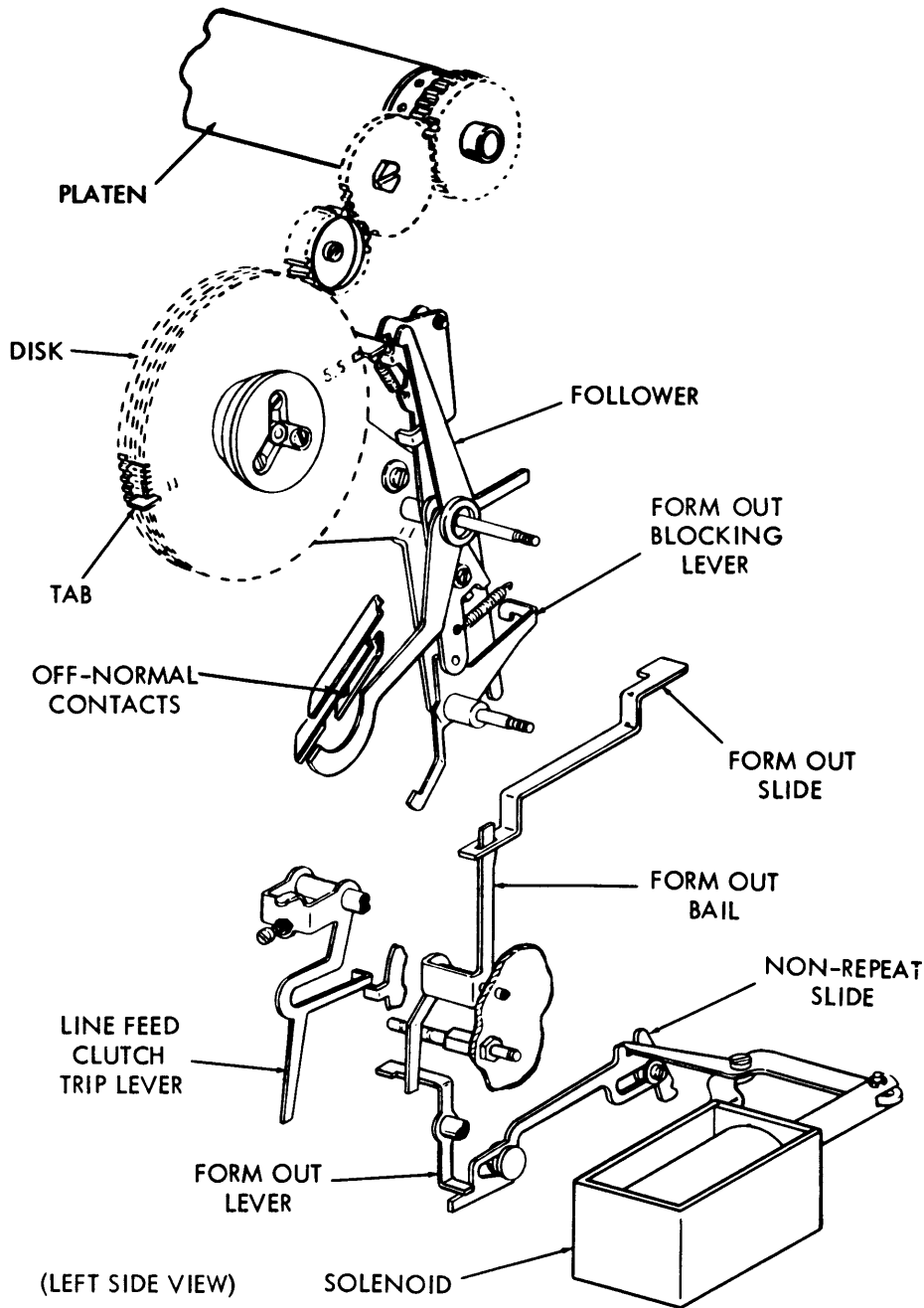

Figure 49 - Form Out Mechanism (Sprocket Feed)

the pawl spring until the bail is fully operated. When the transfer bail is in its operated position, the space suppression slide is operated, and further normal spacing is prevented. If the clutch were to continue to rotate, the spacing drum will continue to rotate after the transfer bail reaches its operated position. At this time, the bail reaches a fixed stop, but the extension pawl pivots about the lower pivot point, permitting the cut-out lever on the drum to go by the pawl. The transfer bail and the extension pawl will then return to their unoperated positions. When the carriage returns, the space cut-out lever engages the upper surface of the extension pawl, causing the pawl to pivot about the mounting shaft until the cut-out lever is able to go by the pawl. The extension pawl is then returned to its unoperated position.

5.10 A set of contacts, the forward contacts interrupting operation of an associated transmitter distributor set during the tabulation operation, the rear operating a motor hold mechanism external to the typing unit, are operated simultaneously when the operating lever is in operating position.

FORM OUT AND VERTICAL TABULATION

5.11 Ten form starter gears and disks (Fig. 49) are available to adapt sprocket feed typing unit to form out accommodation of forms two to fifteen inches in length with vertical tabulation in 1-inch increments, or of two to ten inches in length with vertical tabulation in 1/2-inch increments. The form out mechanism automatically advances a form to the first printing line on the succeeding form from any point on the previous form. The vertical tabulation mechanism advances a form to any pre-determined position within the form.

5.12 When the input signal code combination representing form out is received, mechanical linkage activated by the stunt box trips the form out mechanism. In addition, the form out mechanism is tripped whenever the data set disconnects, unless the paper is already between forms. The data set energizes a form out solenoid during the disconnect sequence if the off normal contacts are closed.

5.13 The sequence of operation of vertical tabulation is similar to that of the form out mechanism (5.11-5.12). When an input signal code combination representing vertical tabulation is received, the associated function mechanism operates a vertical tabulation slide. The slide, moving forward, engages the line feed slide, which in turn engages the line feed clutch (2.80). The vertical tabulation blocking lever blocks the vertical tabulation slide in operated position, allowing the line feed clutch to rotate continuously.

5.14 The vertical tabulation slide remains blocked by the blocking lever until the tabulation index plate on the disk engages the bail which in turn rotates the blocking lever counterclockwise, allowing the vertical tabulation slide and the line feed slide to return to their unoperated position. The line feed clutch is disengaged, and the function mechanism is stripped to its unoperated position.

5.15 A set of transmitter control and motor hold contacts operates on both form out and vertical tabulation cycling. The lower contacts are opened when either cycle begins, to interrupt circuits to an external transmitter distributor set. The upper contacts are simultaneously closed, to operate an external motor hold mechanism.

35 TYPING UNIT (LP)

LUBRICATION

CONTENTS	PAGE	CONTENTS	PAGE
1. GENERAL	1	Track guide mechanism	24
2. BASIC UNIT	5	Typebox carriage mechanism	6
Carriage return mechanism	23	Vertical positioning mechanism	13, 14
Code and print areas	7		
Codebar detents	8	3. VARIABLE FEATURES	37
Codebar mechanism	7, 15	Form-out mechanism	42
Dashpot mechanism	22	Horizontal tabulator area	37
Function reset bail mechanism	20	Horizontal tabulator — bail	
Function rocker shaft mechanism	19	extension arm	40
Horizontal positioning drive		Horizontal tabulator — blocking	
mechanism	26	lever	38
Horizontal positioning mechanism	24, 25	Horizontal tabulator — intermediate	
Line feed area	32	bail	39
Line feed mechanism (friction feed)	33	Horizontal tabulator — latch bail	39
Line feed mechanism		Horizontal tabulator — operating	
(sprocket feed)	36	lever	38, 39
Main shaft area	28	Horizontal tabulator — slide arm	38
Main shaft (clutches, gears, etc)	28, 29	Keyboard lock mechanism	46
Oscillating mechanism	27	Local backspace mechanism	45
Paper feed mechanism		Low paper and paper-out alarm	
(friction feed)	9	mechanism (sprocket feed)	46
Positioning area	11	Paper jam alarm (sprocket feed)	47
Printing area	5	Paper-out alarm mechanism	
Printing mechanism	5, 6	(friction feed)	45
Print suppression mechanism	8	Print-nonprint solenoid mechanism	40
Ribbon area	9	Spacing cut-out transfer bail	40
Ribbon feed mechanism	10, 12	Two color ribbon shift mechanism —	
Ribbon reverse mechanism	19	oscillating lever	44
Selector cam clutch assembly	29	Two color ribbon shift mechanism —	
Selector mechanism	15, 16	ribbon operating mechanism	44
Shift mechanism	26	Typing unit (sprocket feed)	37
Shift selector mechanism	31, 32	Vertical tabulator and transmitter	
Single-double line feed mechanism	34	distributor control mechanism	41
Spacing and drive area	21	Vertical tabulator mechanism (for	
Spacing clutch trip cam		switched network service)	43
mechanism	30		
Spacing drum feed mechanism	23	1. GENERAL	
Spacing drum mechanism	22	1.01 This section provides lubrication for the	
Spacing mechanism	30, 31	35 typing unit. It is reissued to include	
Sprocket feed paper mechanism	36	lubrication for the paper jam alarm, recent	
Stripper blade mechanism	18	engineering information and to update general	
Stunt box area	16	format. Since it is an extensive revision, mar-	
Stunt box mechanism	17	ginal arrows used to indicate changes have been	
Trip shaft mechanism	29	omitted.	

SECTION 574-220-701TC

1.02 Lubricate the 35 typing unit as directed in this section. The line drawings indicate points to be lubricated and the type and quantity of lubricant to be used. Figures 1 and 2 illustrate the general areas of lubrication on the friction feed unit and Figure 3 shows the lubrication areas on the sprocket feed unit. Lubricate the typing unit prior to placing it in service. Relubricate after a few weeks to make sure that all points have received proper lubrication. Thereafter, lubricate the typing unit at intervals of 1500 hours or six months, whichever occurs first.

1.03 Use KS7470 oil at all locations where the use of oil is indicated. Use KS7471 grease at all locations where the use of grease is indicated.

1.04 Saturate all spring wicks and felt oilers. Thoroughly lubricate the friction surfaces of all moving parts. However, avoid over-lubrication which permits oil or grease to drip or be thrown on other parts. Take special care to prevent any oil or grease from getting between the selector armature and its magnetic pole faces. Keep all electrical contacts free of oil and grease.

1.05 Apply a thin film of grease to the teeth of the range scale knob assembly (knob and gear).

1.06 Apply a thick film of grease to all gears and the spacing trip lever bail cam plate.

1.07 Apply oil to all cams, including the camming surfaces of each clutch disc.

1.08 Grease the clutch shoe lever spring loops and completely saturate the internal mechanism of the clutch assembly with oil.

1.09 Apply a thin film of oil around the outer periphery of the dashpot cup and retainer. Avoid excessive lubrication that will obstruct the dashpot parts.

1.10 The photographs serve as a guide to mechanism locations on the unit. They are also keyed to the paragraph numbers of line drawings of particular mechanisms. Parts in the line drawings are shown in an upright position unless otherwise specified. References to left, right, top, bottom, front, rear, etc, apply to the unit in its normal operating position as viewed from the operator's position in front of the unit.

1.11 The illustration symbols indicate the following lubrication directions.

<u>Symbol</u>	<u>Meaning</u>
O1	Apply 1 drop of oil.
O2	Apply 2 drops of oil.
O3	Apply 3 drops of oil, etc.
G	Apply thin film of grease.
SAT	Saturate (felt oilers, washers, wicks) with oil.

Note: During each lubrication period, check the following adjustments in Section 574-220-700TC.

1. Printing Carriage Position
2. Printing Hammer Bearing Stud
3. Printing Hammer Stop Bracket (Also see note following this adjustment.)
4. Lower Draw Wire Rope
5. Dashpot Vent Screw (Check Dashpot Transfer Slide for ease of movement.)

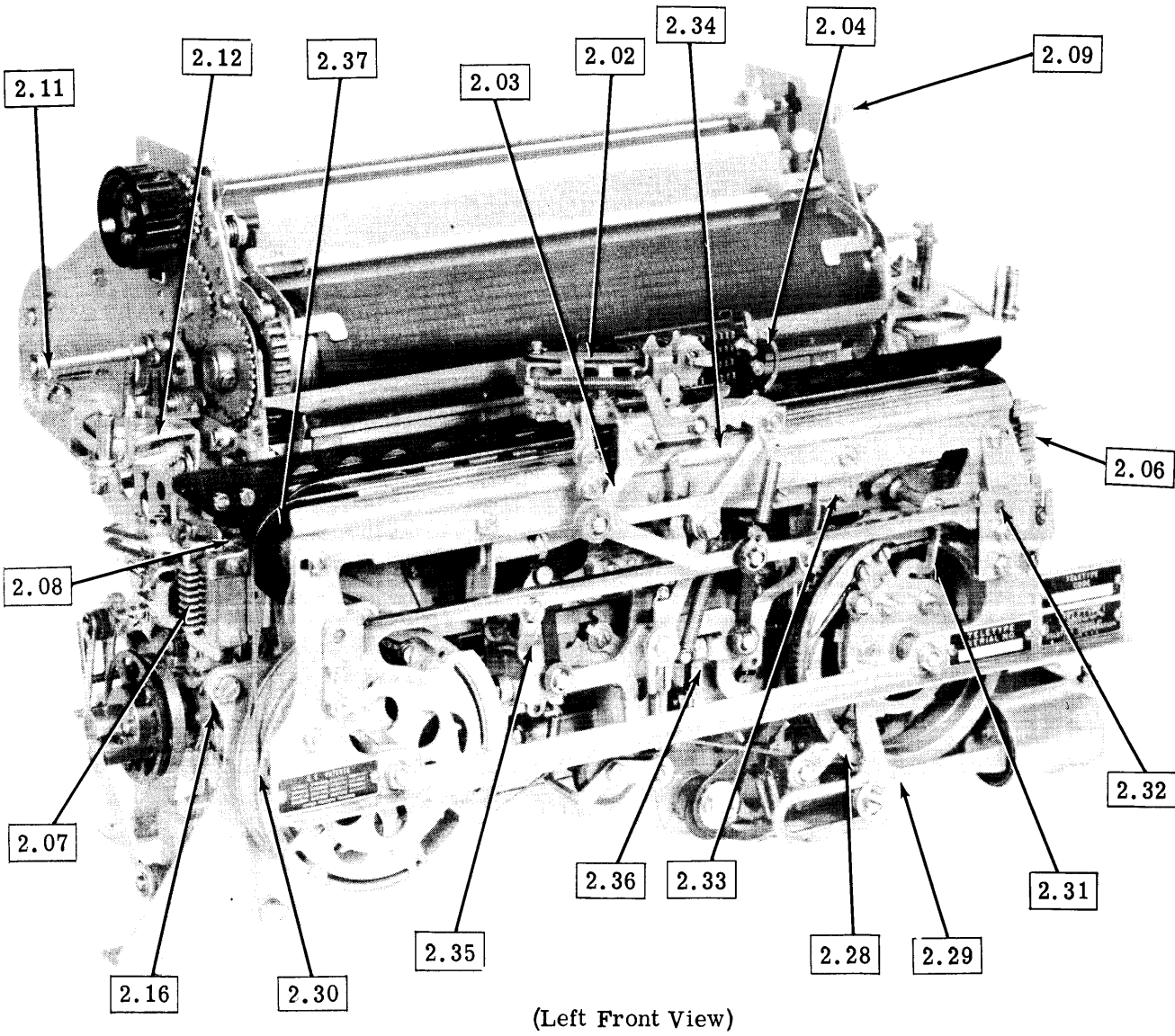

Figure 1 - 35 Typing Unit, Friction Feed

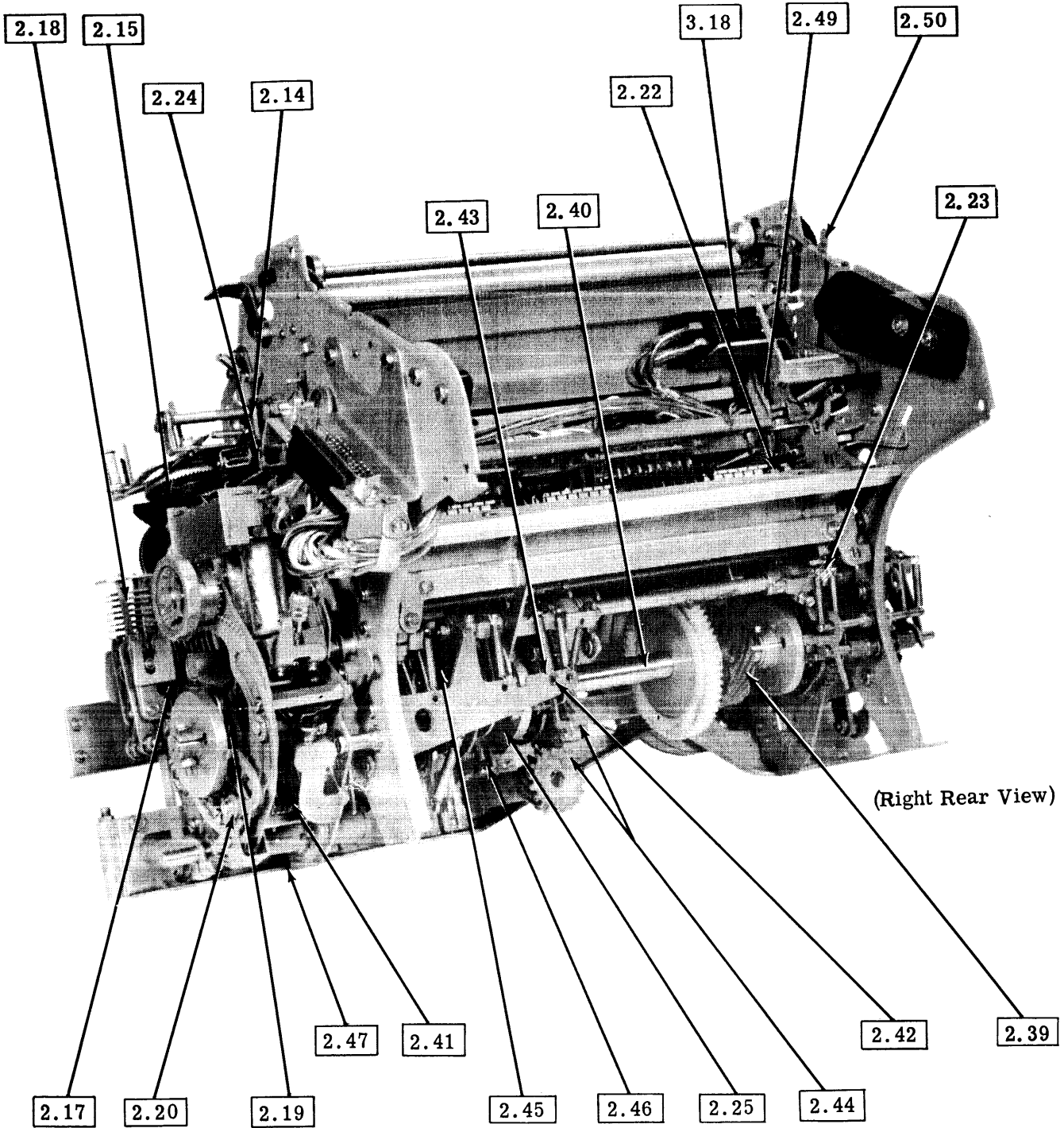
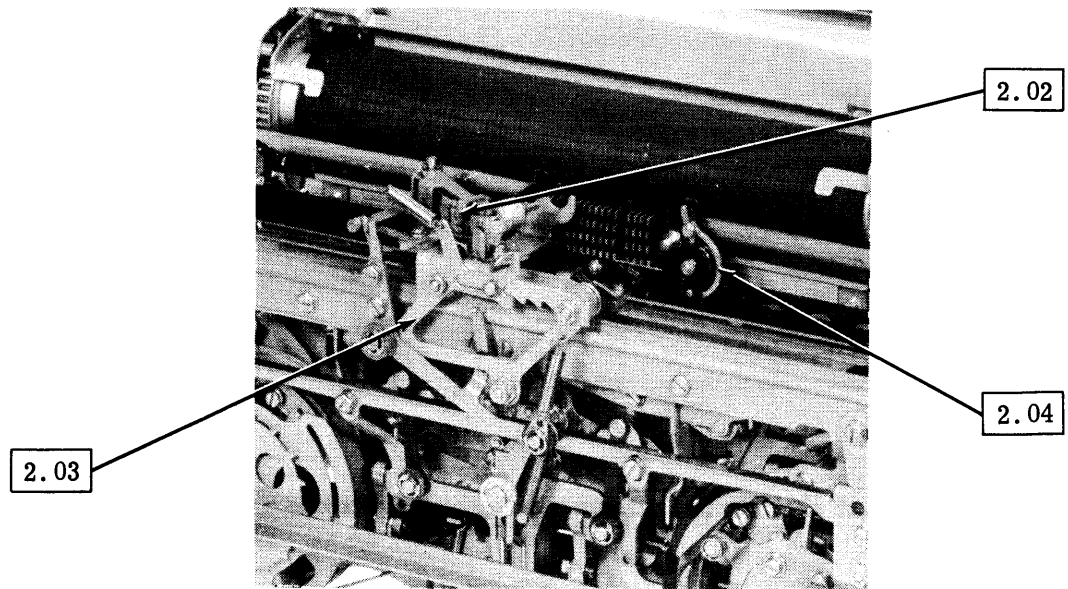

Figure 2 - 35 Typing Unit, Friction Feed

2. BASIC UNIT

2.01 Printing Area



(Front View)

2.02 Printing Mechanism

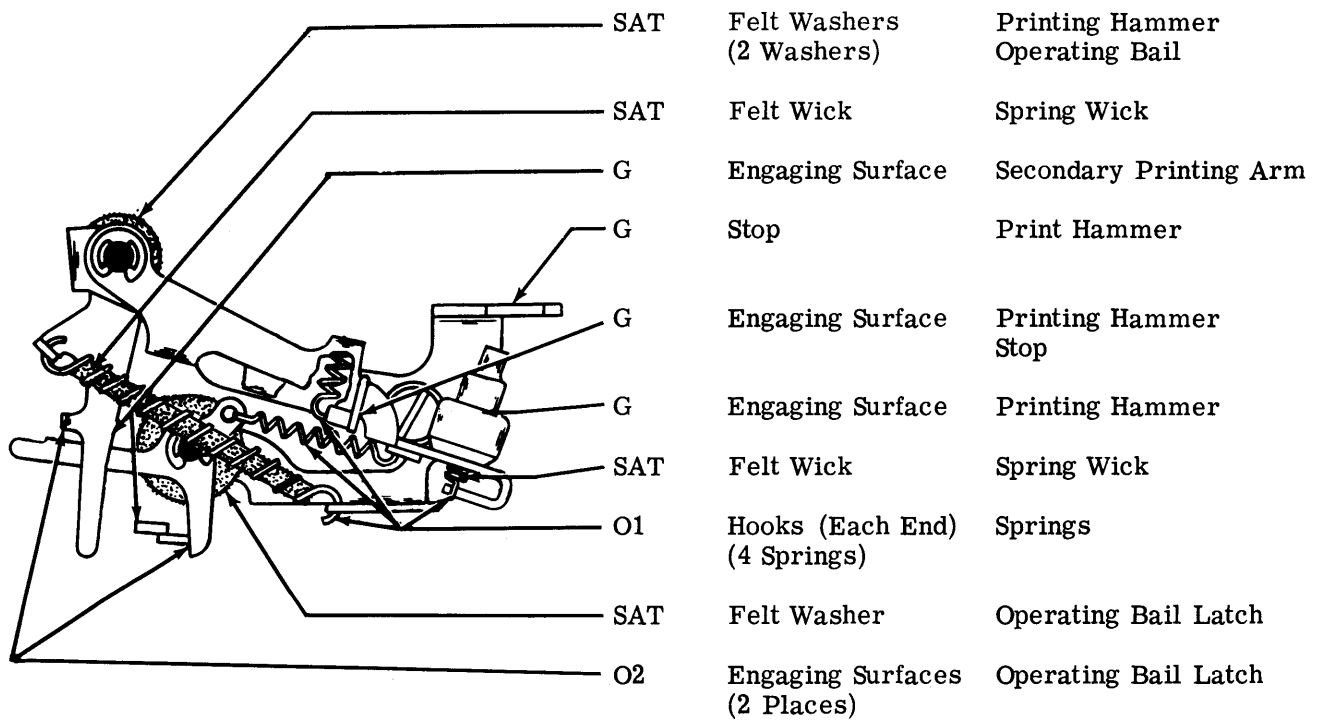

(Top View)

SECTION 574-220-701TC

2.03 Printing Mechanism (continued)

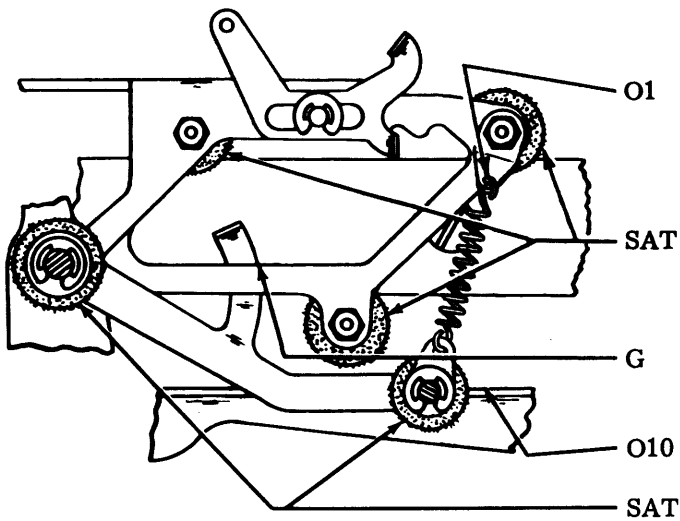

(Front View)

- | | | |
|-----|-----------------------------|------------------------------|
| O1 | Hook (Each End) | Spring |
| SAT | Felt Washers
(3 Washers) | Printing Carriage
Rollers |
| G | Guiding Surface | Printing Arm
Extension |
| O10 | Tracking Surface | Printing Track |
| SAT | Felt Washers
(2 Washers) | Printing Arm |

2.04 Typebox Carriage Mechanism

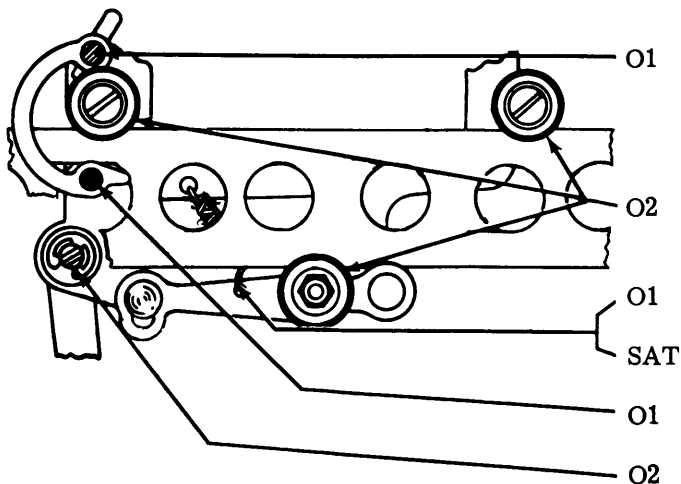

(Rear View)

- | | | |
|-----|-------------------------|-----------------------------|
| O1 | Bearing Surface | Typebox Latch
Toggle |
| O2 | Bearings
(3 Rollers) | Typebox
Carriage Rollers |
| O1 | Hook (Each End) | Spring |
| SAT | Felt Wick | Spring |
| O1 | Bearing Surface | Typebox Latch |
| O2 | Bearing Surface | Typebox
Carriage Link |

2.05 Code and Print Areas

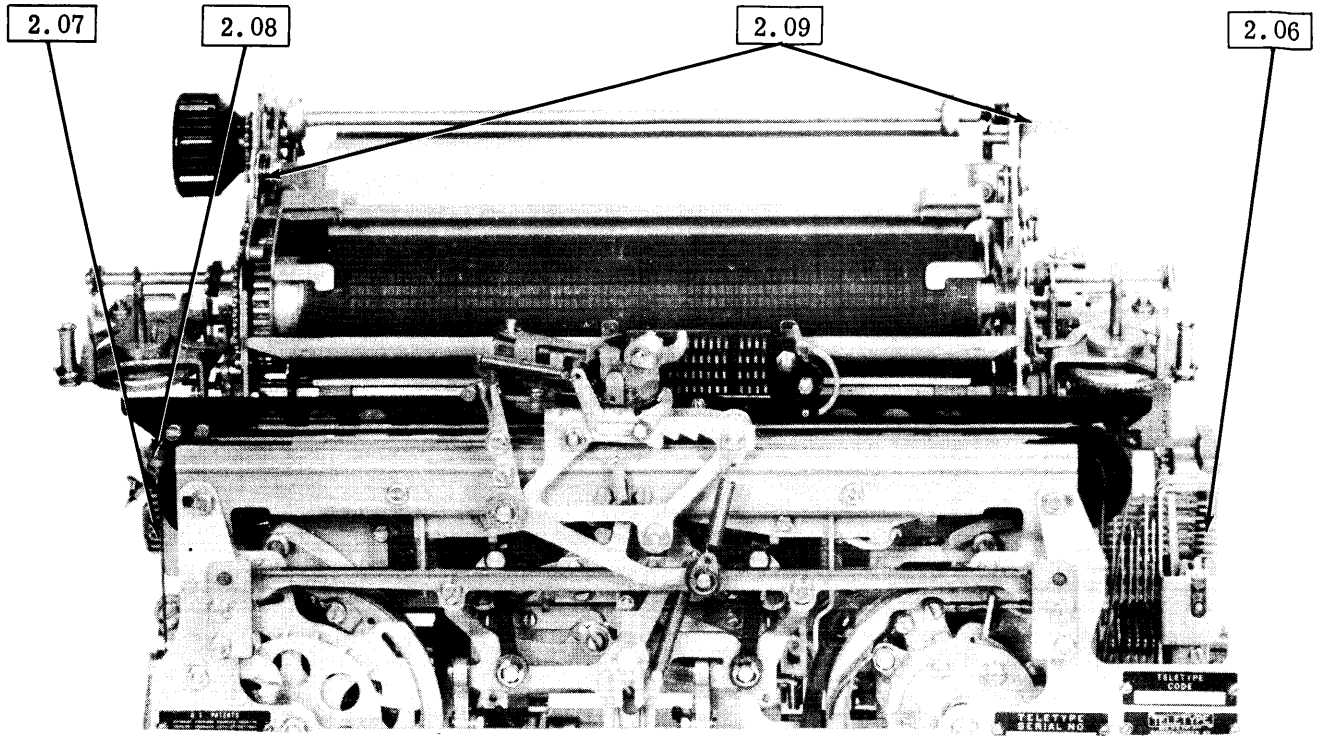

(Front View)

2.06 Codebar Mechanism

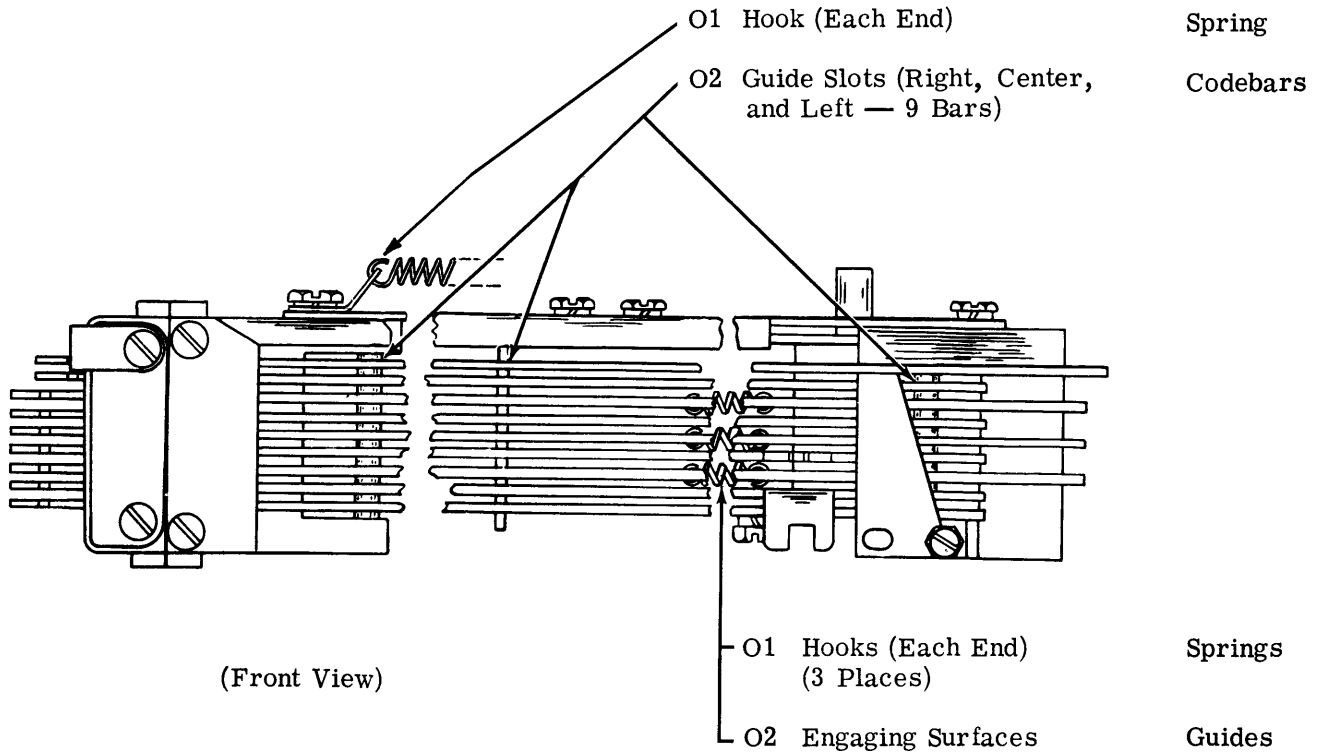

(Front View)

SECTION 574-220-701TC

2.07 Codebar Detents

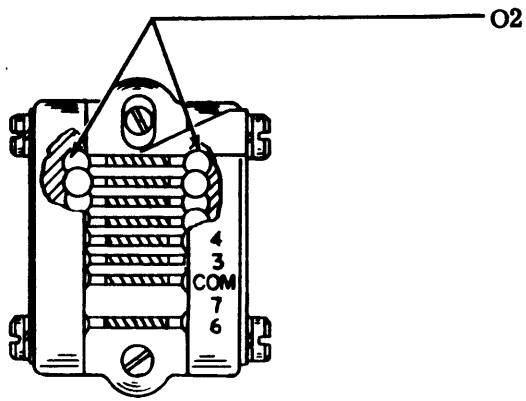

(Left Side View)

Bearing Balls Codebar Detent

2.08 Print Suppression Mechanism

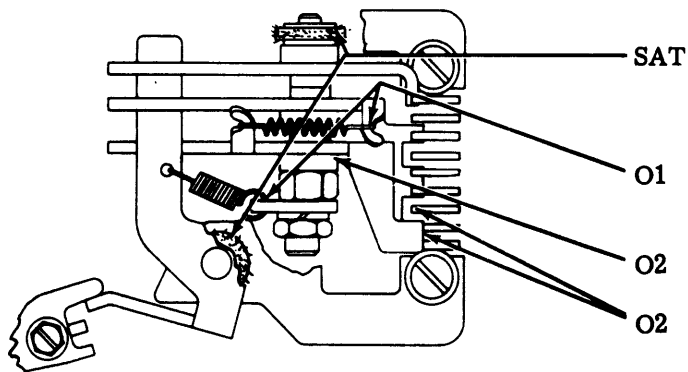

(Left Side View)

SAT	Felt Washers (3 Washers)	Eccentric Post and Blocking Bail Blade
O1	Hooks (Both Ends) (2 Springs)	Springs
O2	Bearing Surface	Eccentric Post
O2	Engaging Surfaces (4 Places)	Blocking Levers

2.09 Paper Feed Mechanism (Friction Feed)

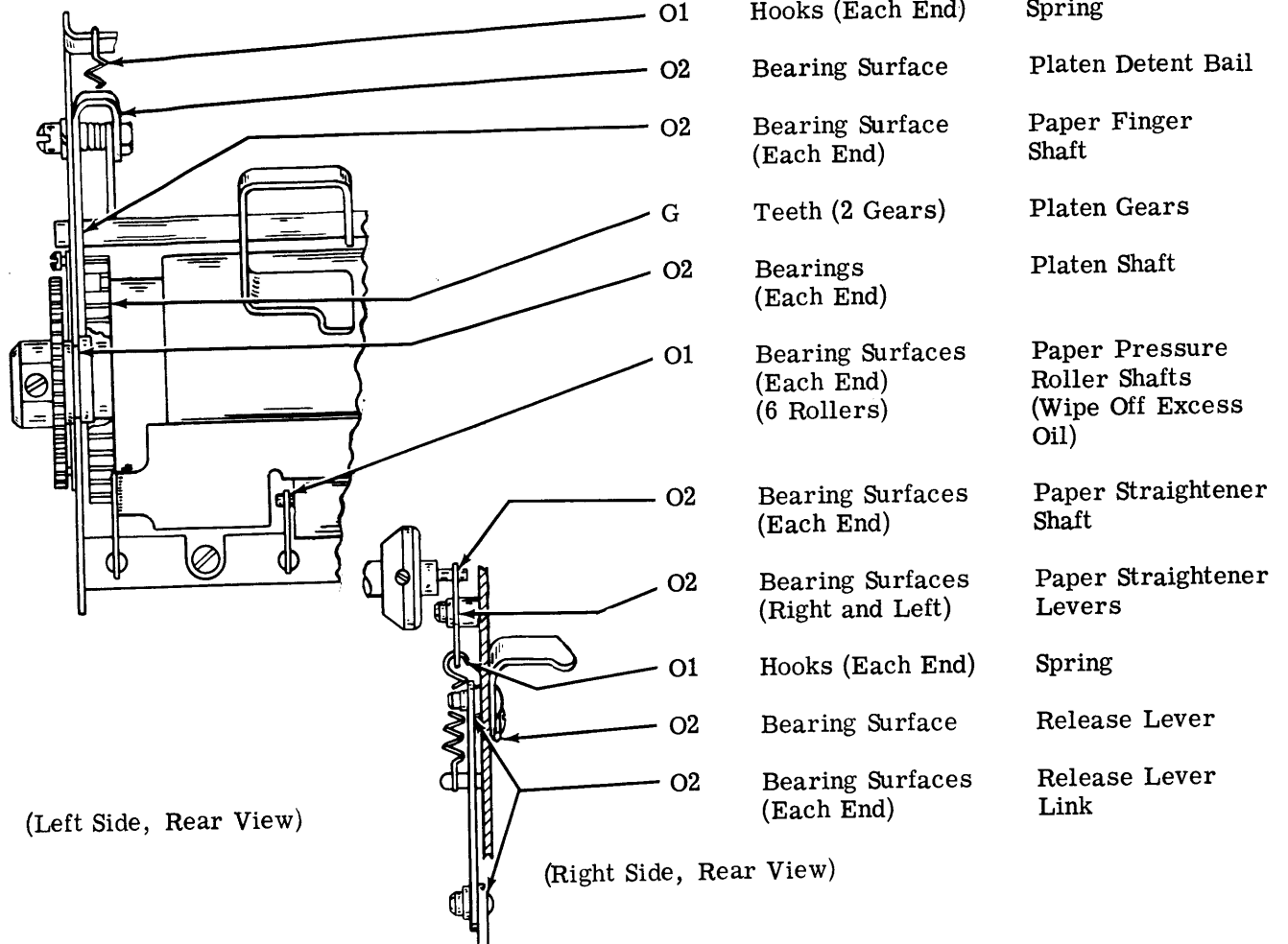

(Left Side, Rear View)

(Right Side, Rear View)

2.10 Ribbon Area

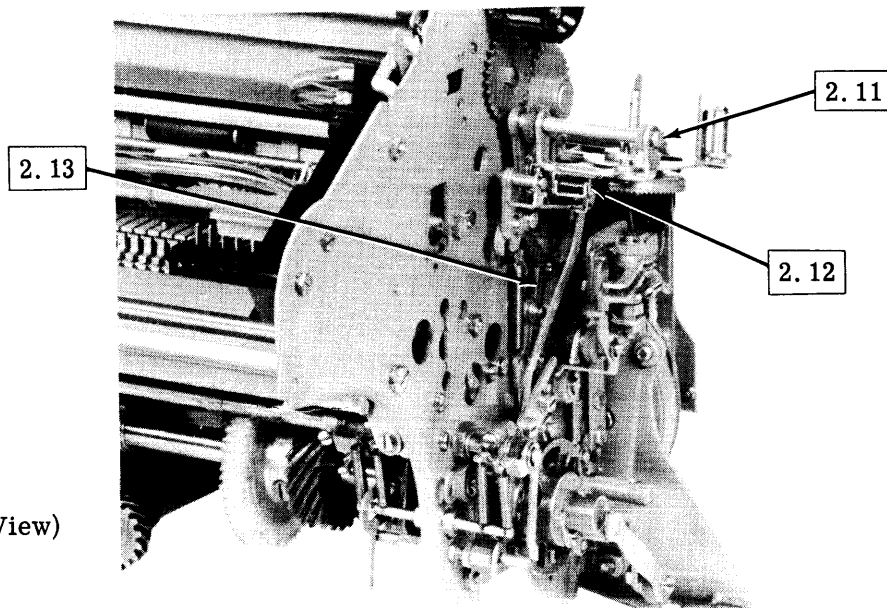

(Left Rear View)

SECTION 574-220-701TC

2.11 Ribbon Feed Mechanism

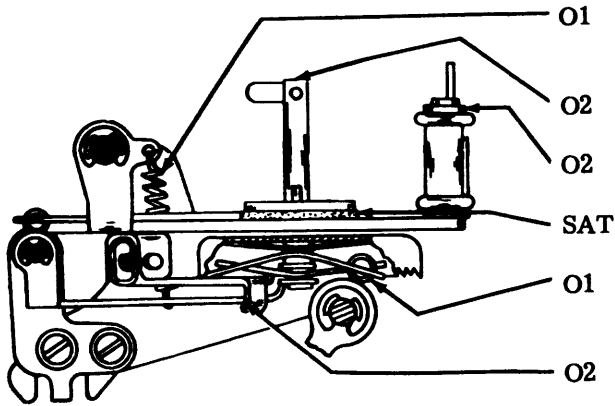

(Left Side View)

- | | | |
|-----|------------------|-----------------------------|
| O1 | Hooks (Each End) | Ribbon Feed Lever Spring |
| O2 | Bearing Surface | Ribbon Spool Toggle |
| O2 | Bearing Surface | Ribbon Roller Shaft |
| SAT | Felt Washer | Ribbon Spool Shaft |
| O1 | Hooks (Each End) | Ribbon Ratchet Wheel Spring |
| O2 | Engaging Surface | Ribbon Detent Lever |

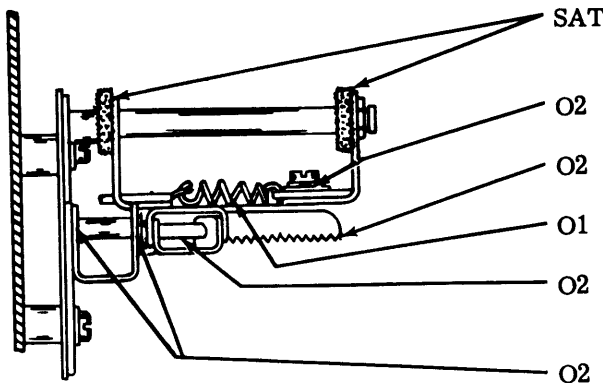

(Rear View)

- | | | |
|-----|--------------------------|---------------------------|
| SAT | Felt Washers (2 Washers) | Ribbon Feed Lever Bail |
| O2 | Bearing Surface | Ribbon Reverse Lever |
| O2 | Teeth | Ribbon Ratchet Wheel |
| O1 | Hooks (Each End) | Spring |
| O2 | Engaging Surface | Ribbon Detent Lever Shaft |
| O2 | Bearing Surfaces | Ratchet Feed Lever Shaft |

2.12 Ribbon Feed Mechanism (continued)

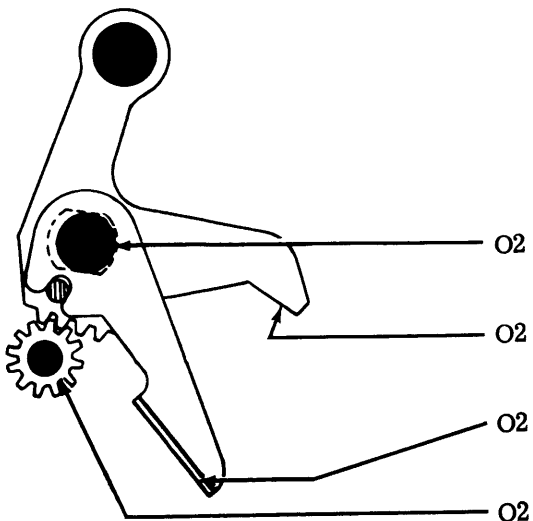

(Left Side View)

- | | | |
|----|------------------|--------------------------|
| O2 | Bearing Surface | Ribbon Reverse Lever |
| O2 | Engaging Surface | Ribbon Reverse Lever |
| O2 | Engaging Surface | Ribbon Reverse Lever |
| O2 | Teeth | Ribbon Reverse Spur Gear |

2.13 Positioning Area

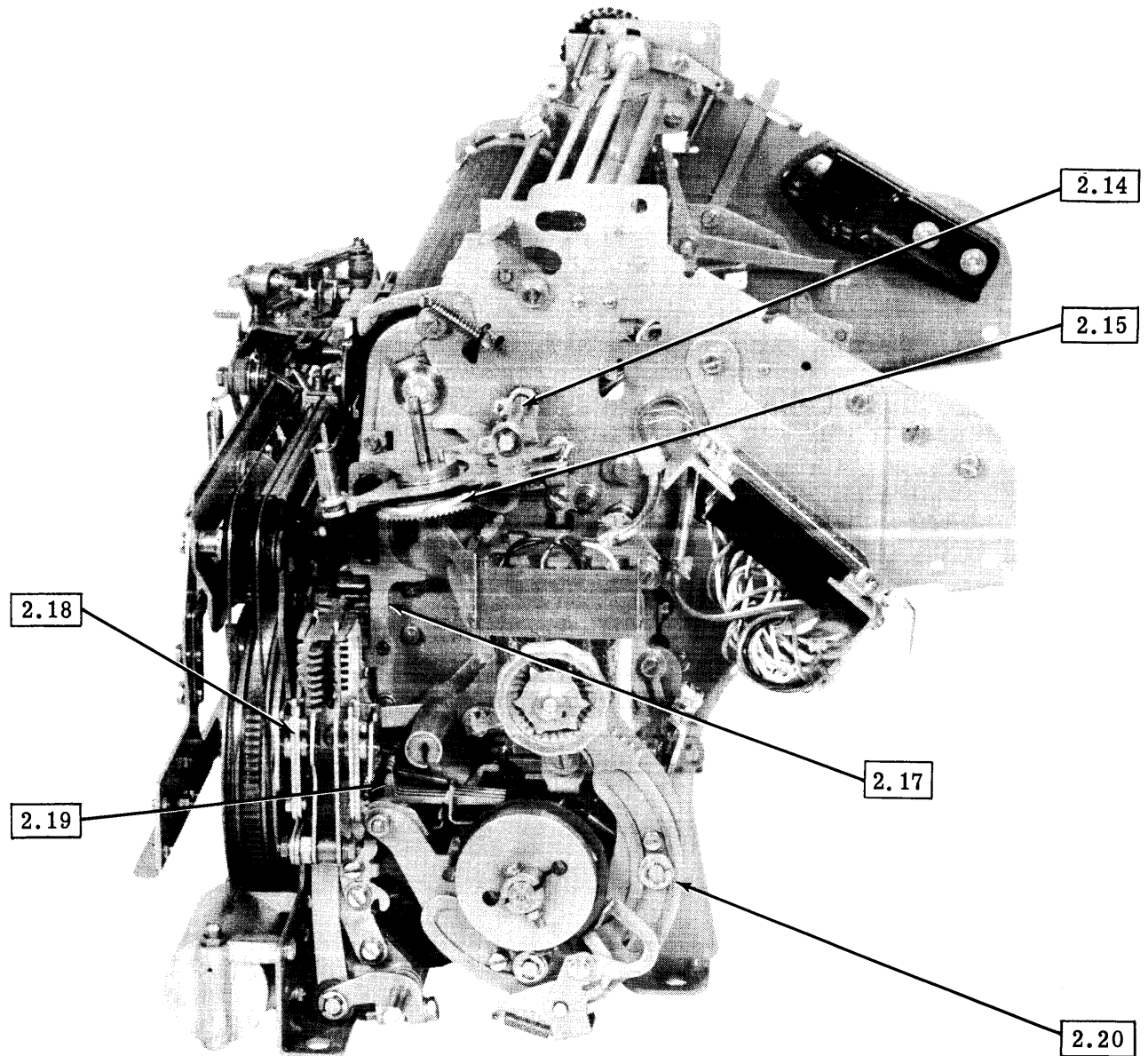

(Right Side View)

2.14 Ribbon Feed Mechanism (continued)

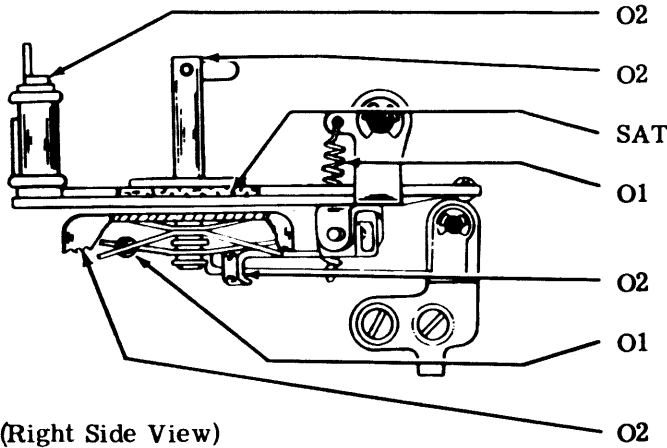

- | | | |
|-----|------------------|-----------------------------|
| O2 | Bearing Surface | Ribbon Roller Shaft |
| O2 | Bearing Surface | Ribbon Spool Toggle |
| SAT | Felt Washer | Ribbon Spool Shaft |
| O1 | Hooks (Each End) | Ribbon Feed Lever Spring |
| O2 | Engaging Surface | Ribbon Detent Lever |
| O1 | Hooks (Each End) | Ribbon Ratchet Wheel Spring |
| O2 | Teeth | Ribbon Ratchet Wheel |

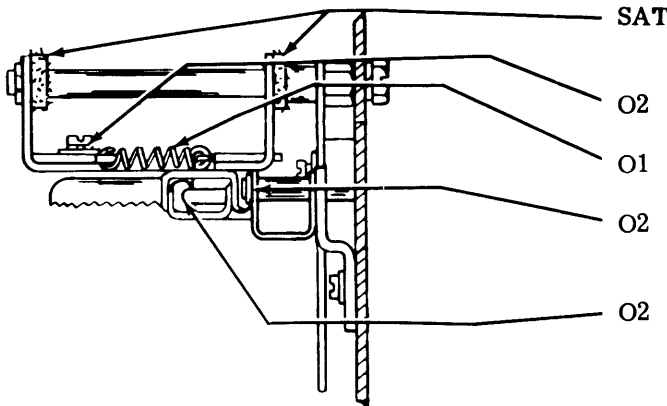

- | | | |
|-----|----------------------------|---------------------------|
| SAT | Felt Washers (2 Washers) | Ribbon Feed Lever Bail |
| O2 | Bearing Surface | Ribbon Reverse Lever |
| O1 | Hooks (Each End) | Spring |
| O2 | Bearing Surfaces | Ratchet Feed Lever Shaft |
| O2 | Bearing Surface (2 Places) | Ribbon Detent Lever Shaft |

.15 Ribbon Feed Mechanism (continued)

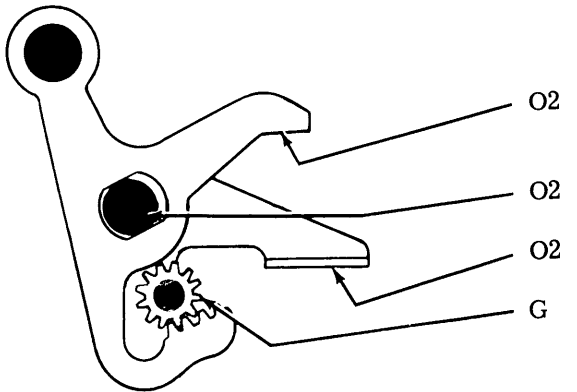

- | | | |
|----|------------------|--------------------------|
| O2 | Engaging Surface | Ribbon Reverse Lever |
| O2 | Bearing Surface | Ribbon Reverse Lever |
| O2 | Engaging Surface | Ribbon Reverse Lever |
| G | Teeth | Ribbon Reverse Spur Gear |

2.16 Vertical Positioning Mechanism

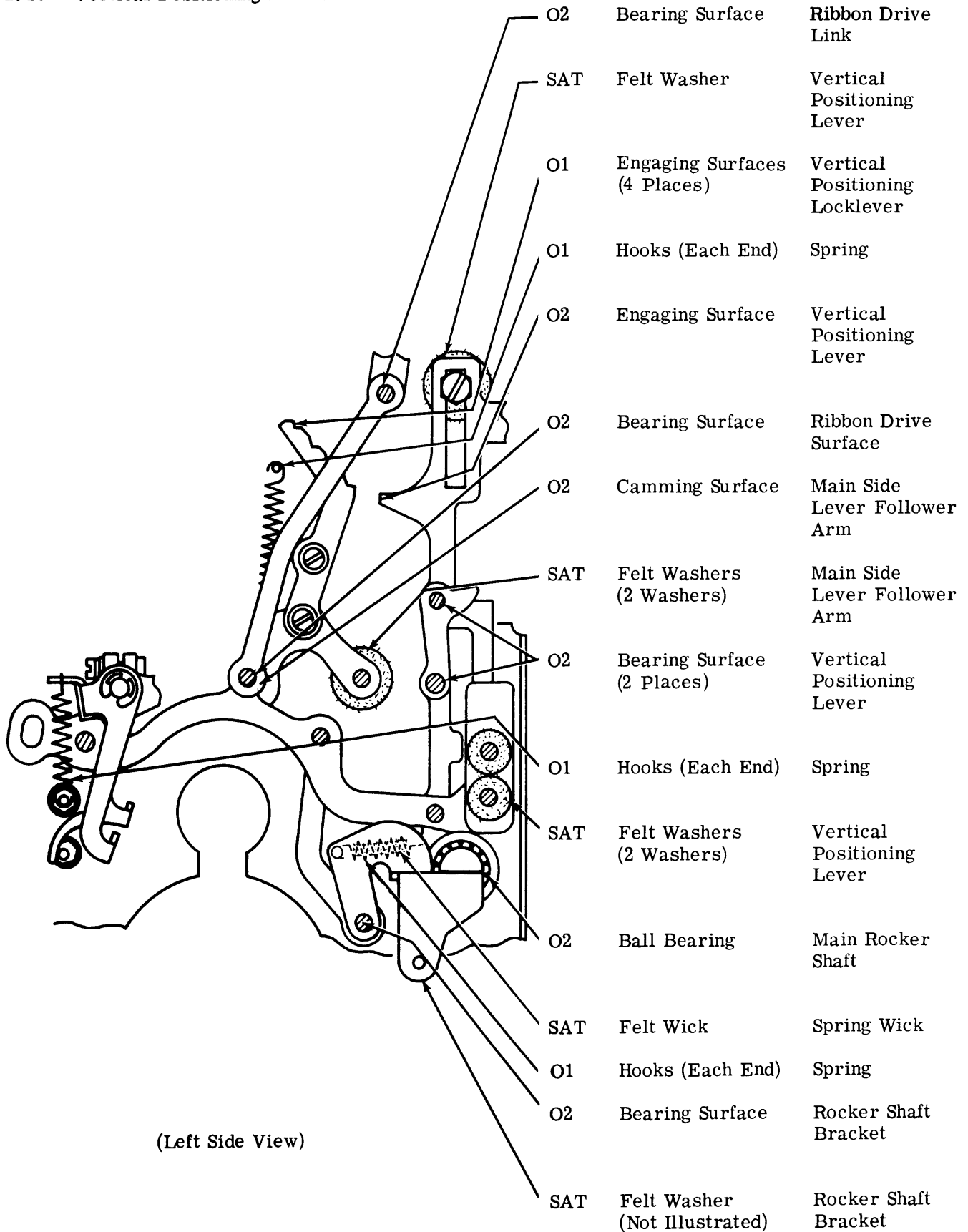

(Left Side View)

2.17 Vertical Positioning Mechanism (continued)

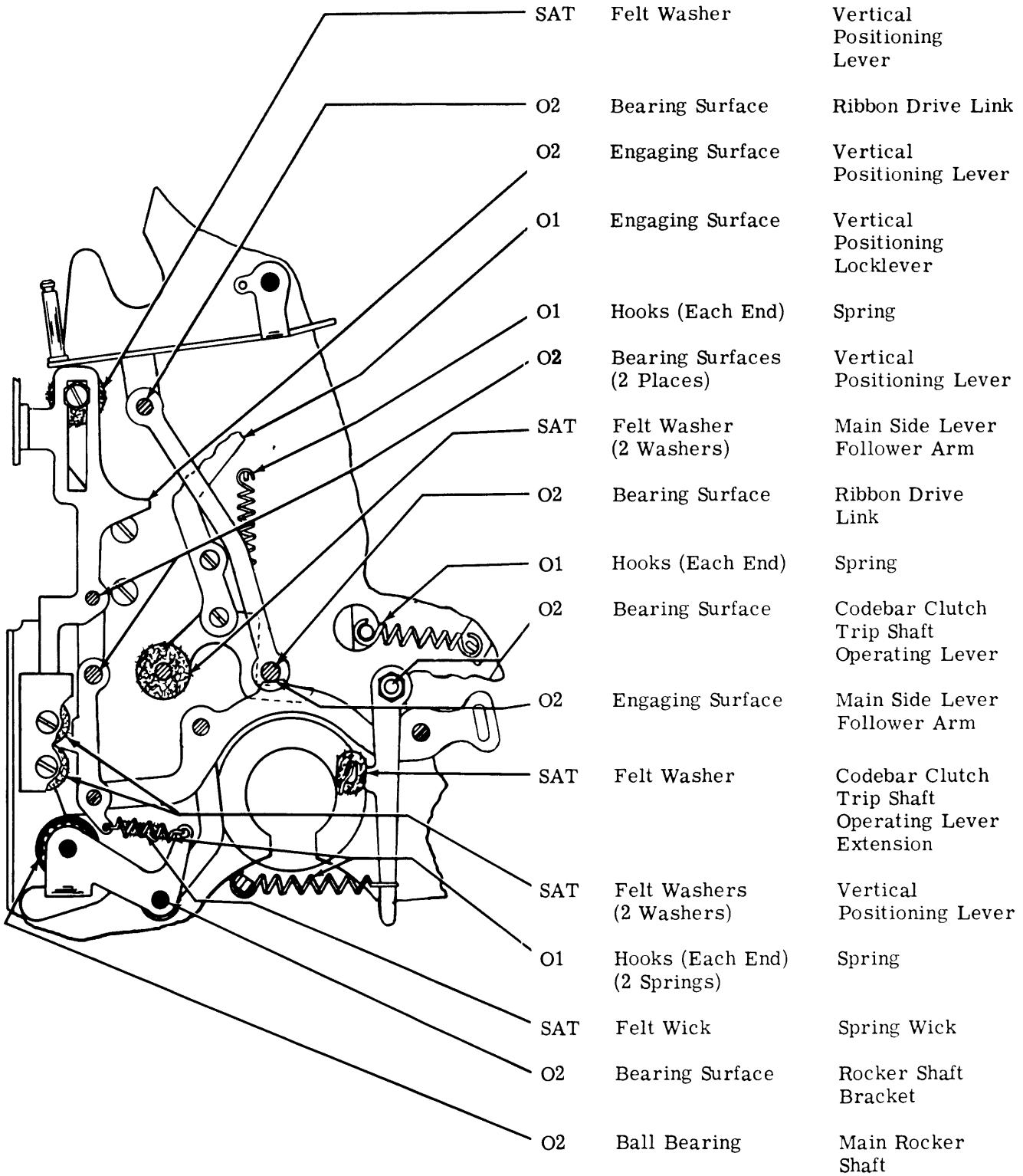

(Right Side View)

2.18 Codebar Mechanism (continued)

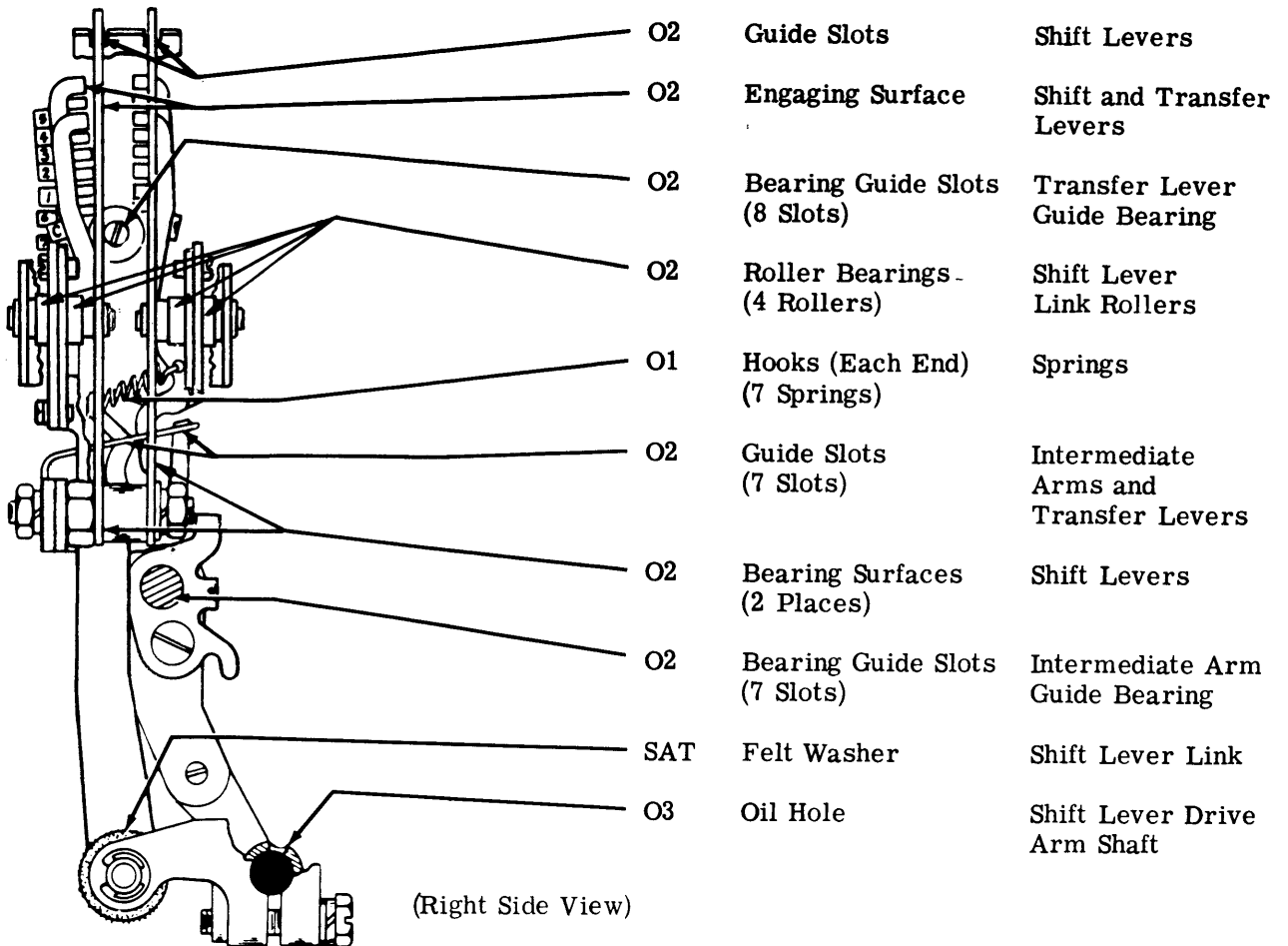

2.19 Selector Mechanism

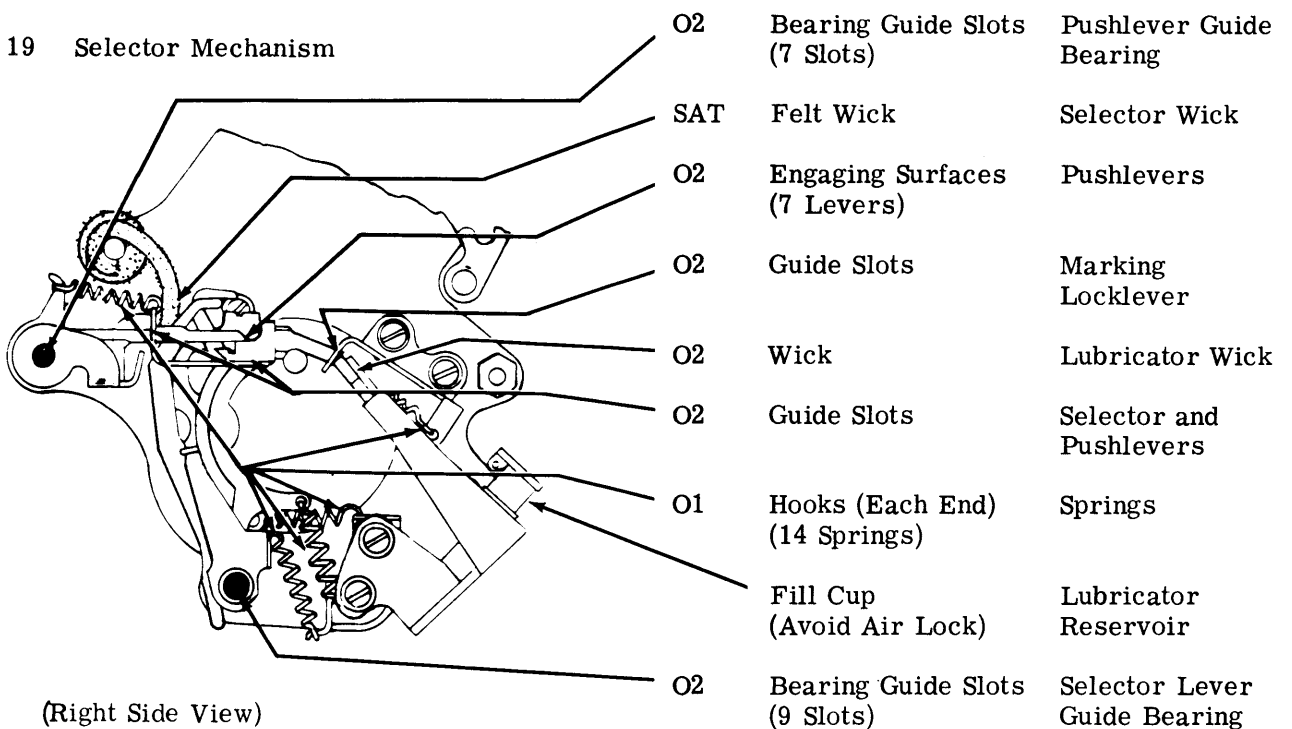

2.20 Selector Mechanism (continued)

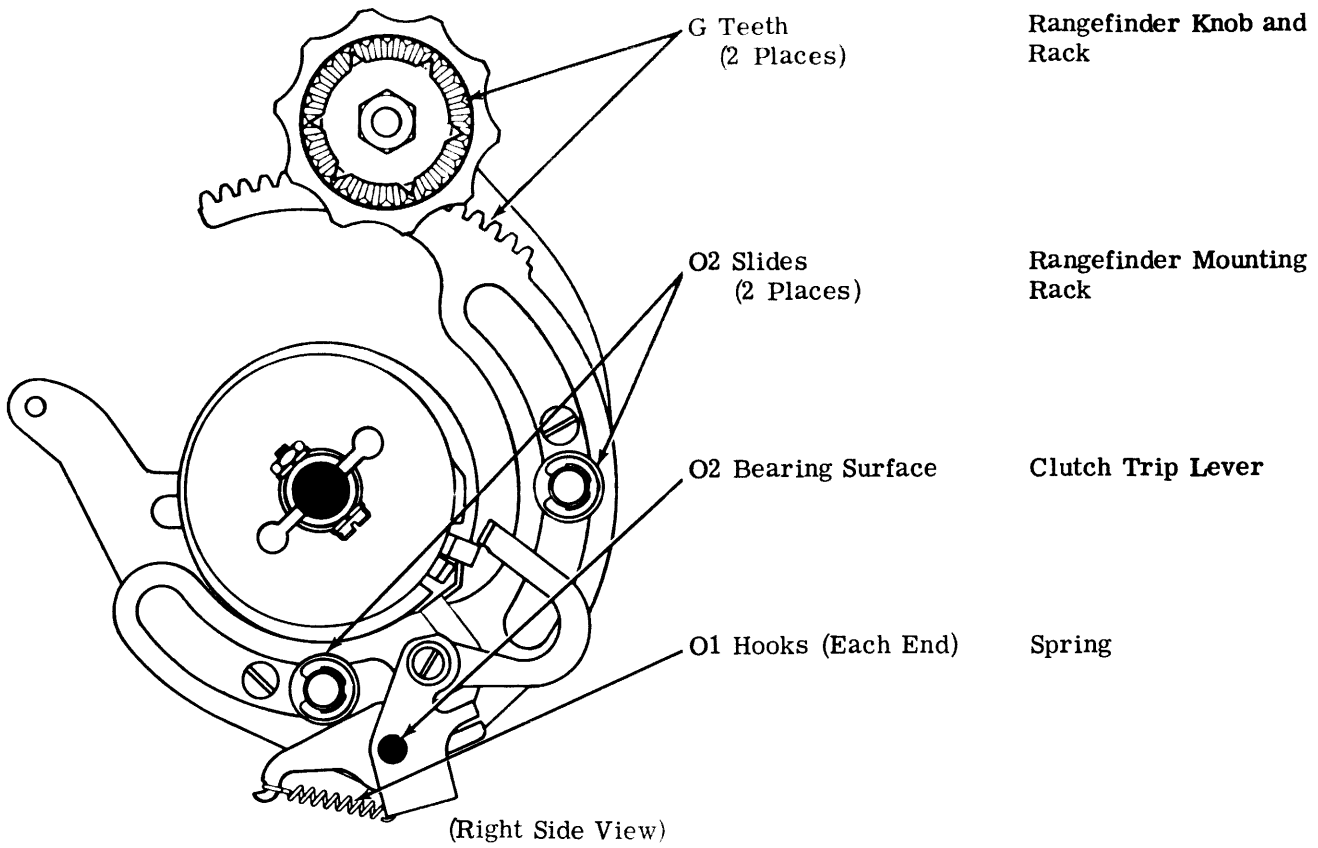

2.21 Stunt Box Area

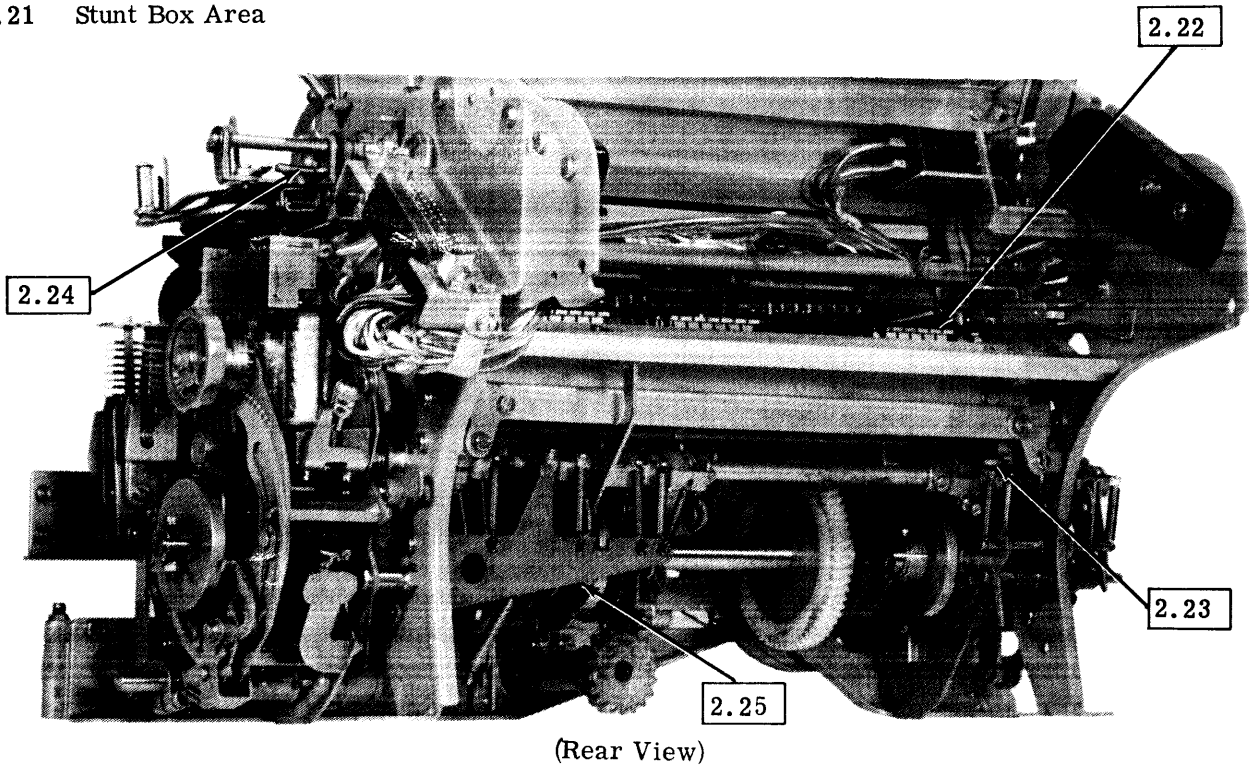

2.22 Stunt Box Mechanism

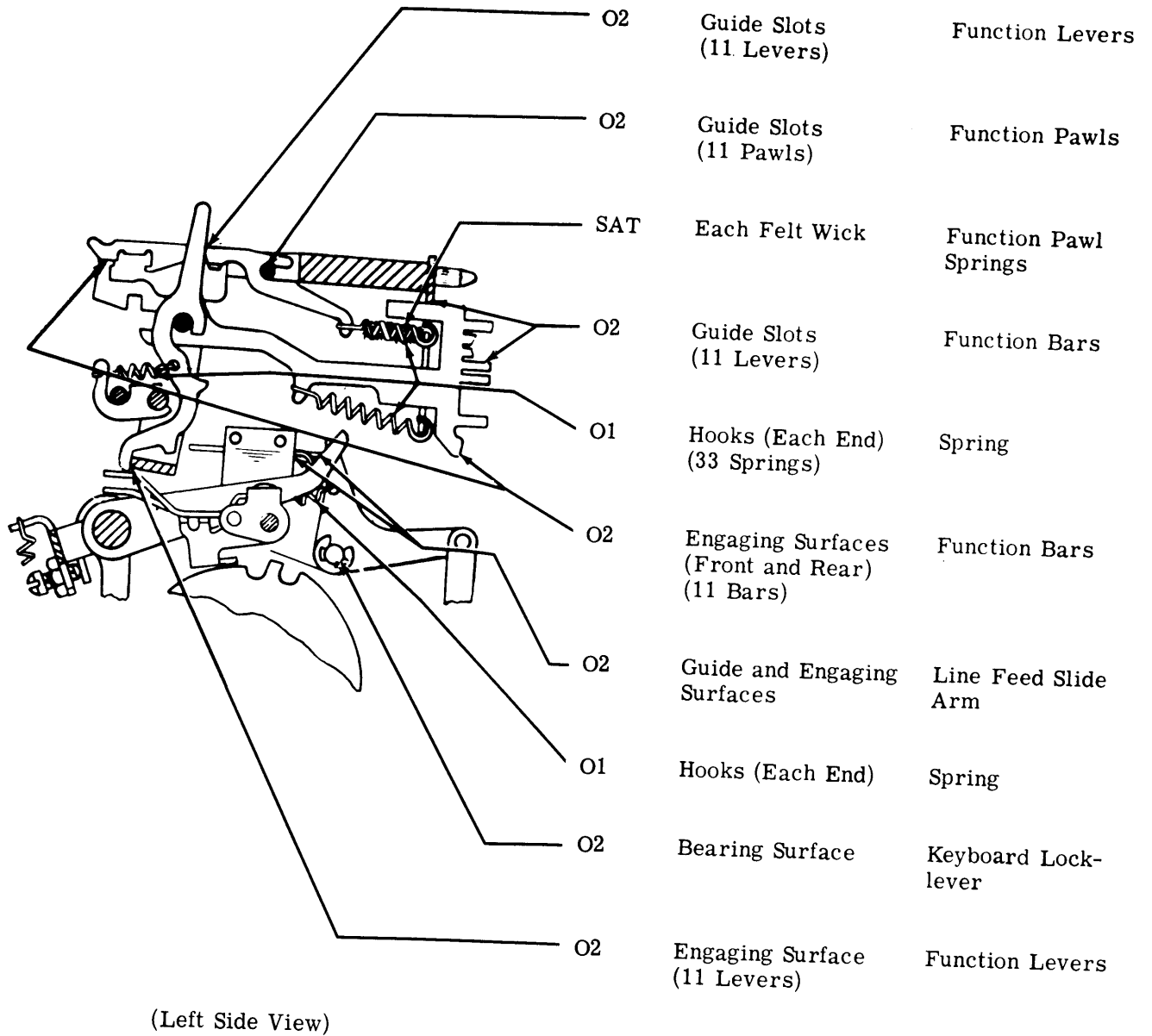

2.23 Stripper Blade Mechanism

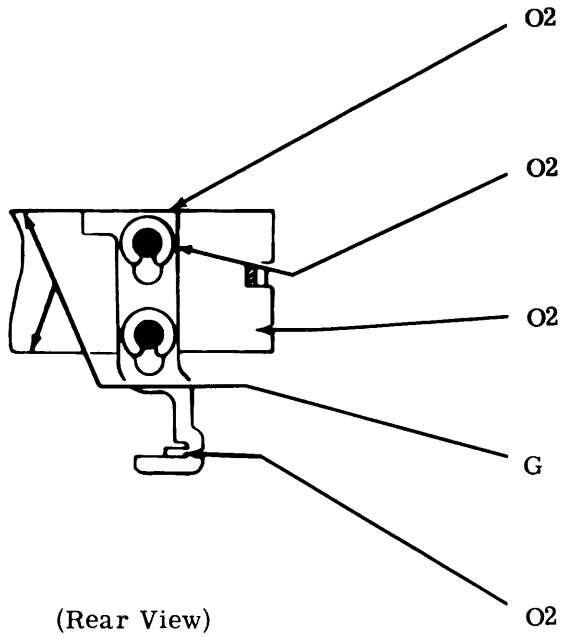

- O2 Engaging Surface Line Feed Stripper Slide
- O2 Guide Surfaces (2 Places) Stripper Slide
- O2 Guide Surfaces (Each End) Stripper Blade
- G Engaging Surfaces (2 Places) Stripper Blade
- O2 Engaging Surface Stripper Bail

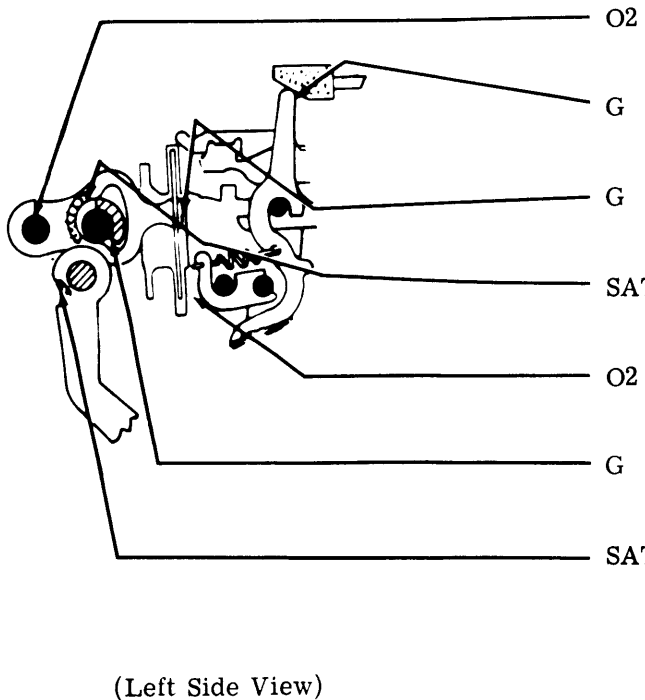

- O2 Bearing Surfaces (2 Bearings) Cam Arms
- G Engaging Surfaces (Each Arm) Contact Arm
- G Engaging Surfaces (2 Arms) Cam Arms
- SAT Felt Washers (4 Washers) Driving Cam
- O2 Guide Slots (Each End) Stripper Blade
- G Camming Surfaces (2 Cams) Driving Cam
- SAT Felt Washer Stripper Blade Driving Arm

2.24 Ribbon Reverse Mechanism

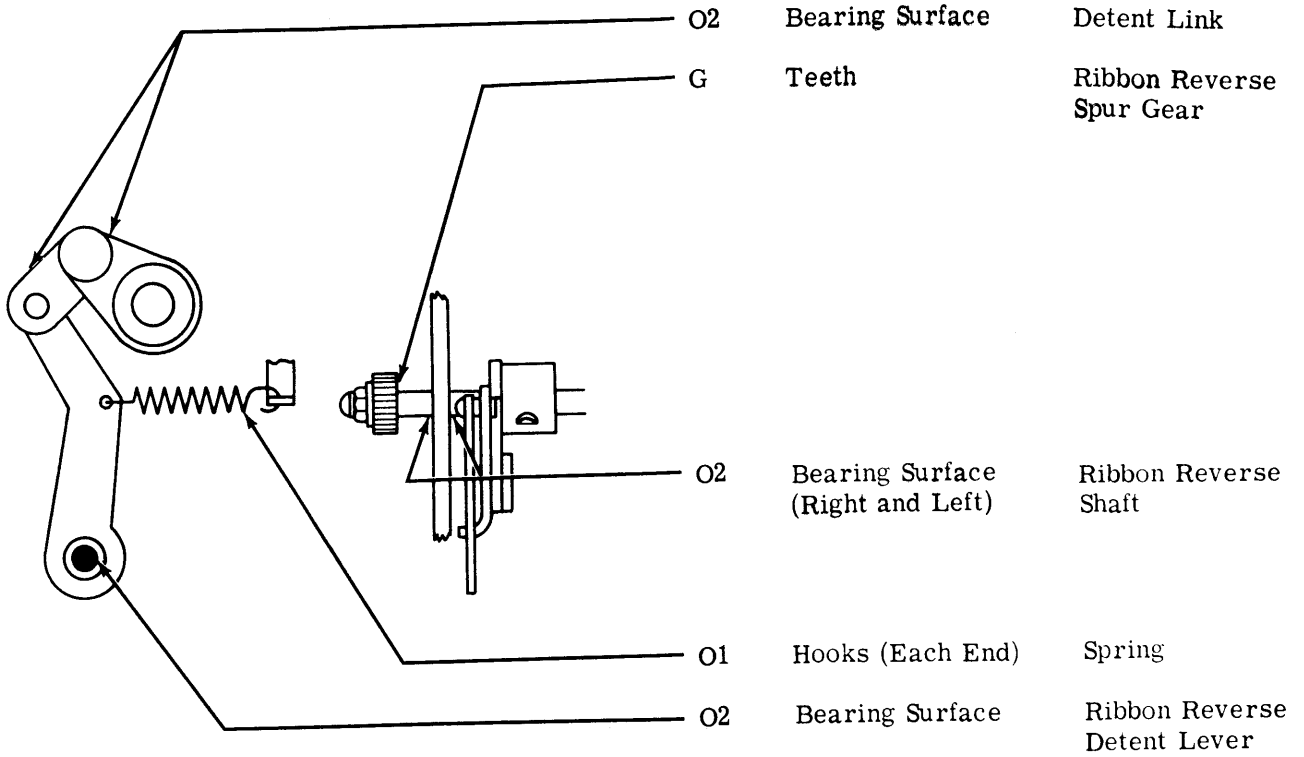

(Right Rear View)

2.25 Function Rocker Shaft Mechanism

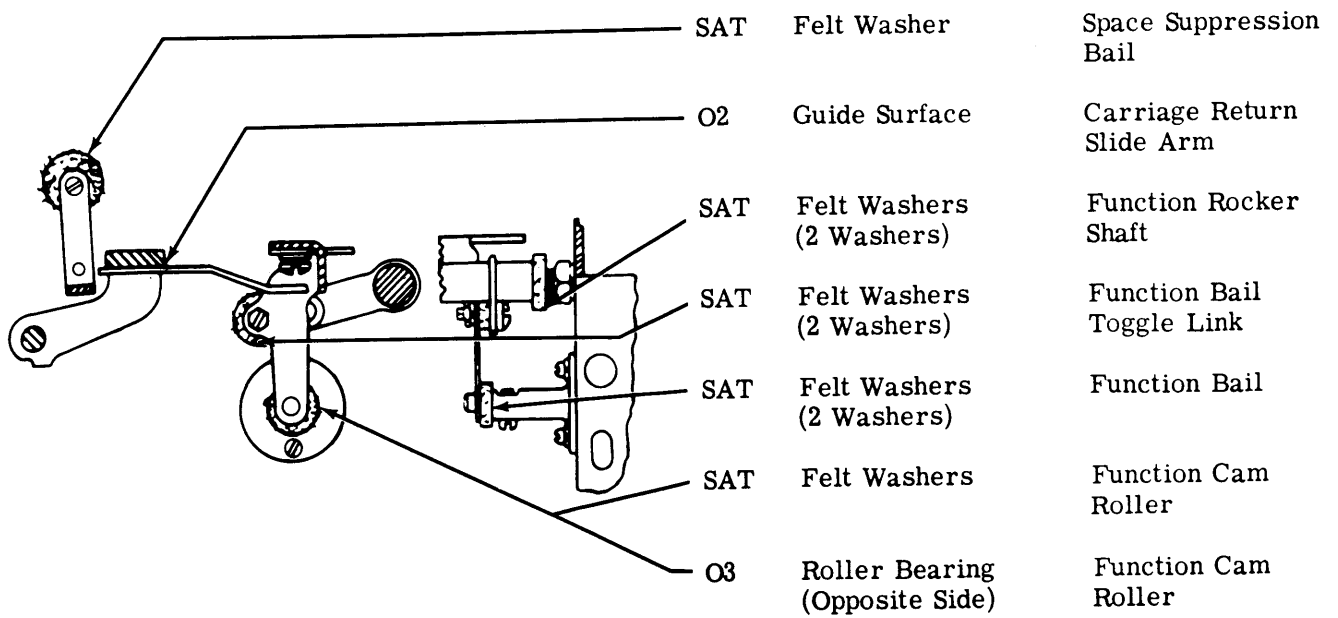

(Left Rear View)

2.26 Function Reset Bail Mechanism

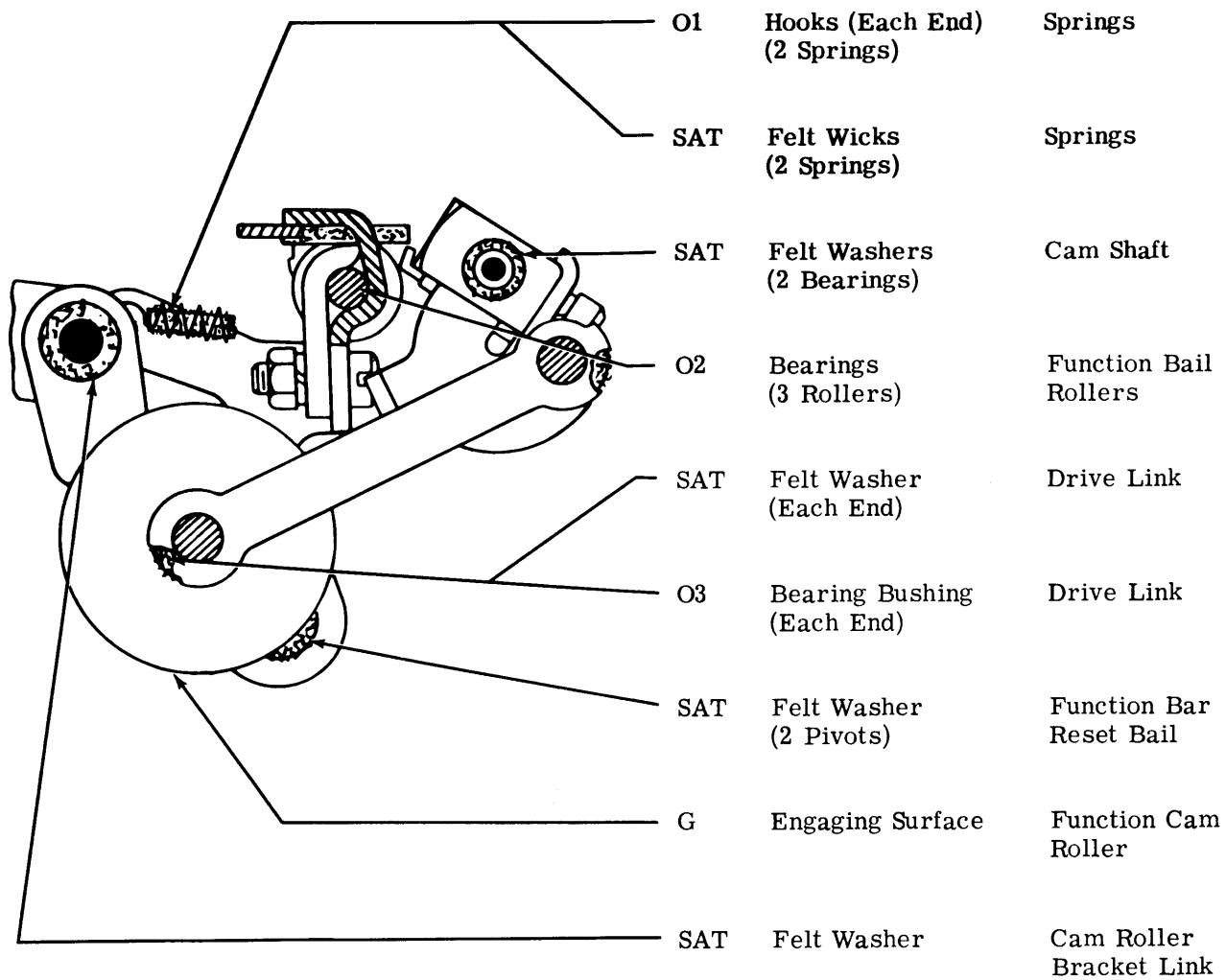

(Left Side View)

Note: See 2.38 for photograph of the location of this mechanism.

2.27 Spacing and Drive Area

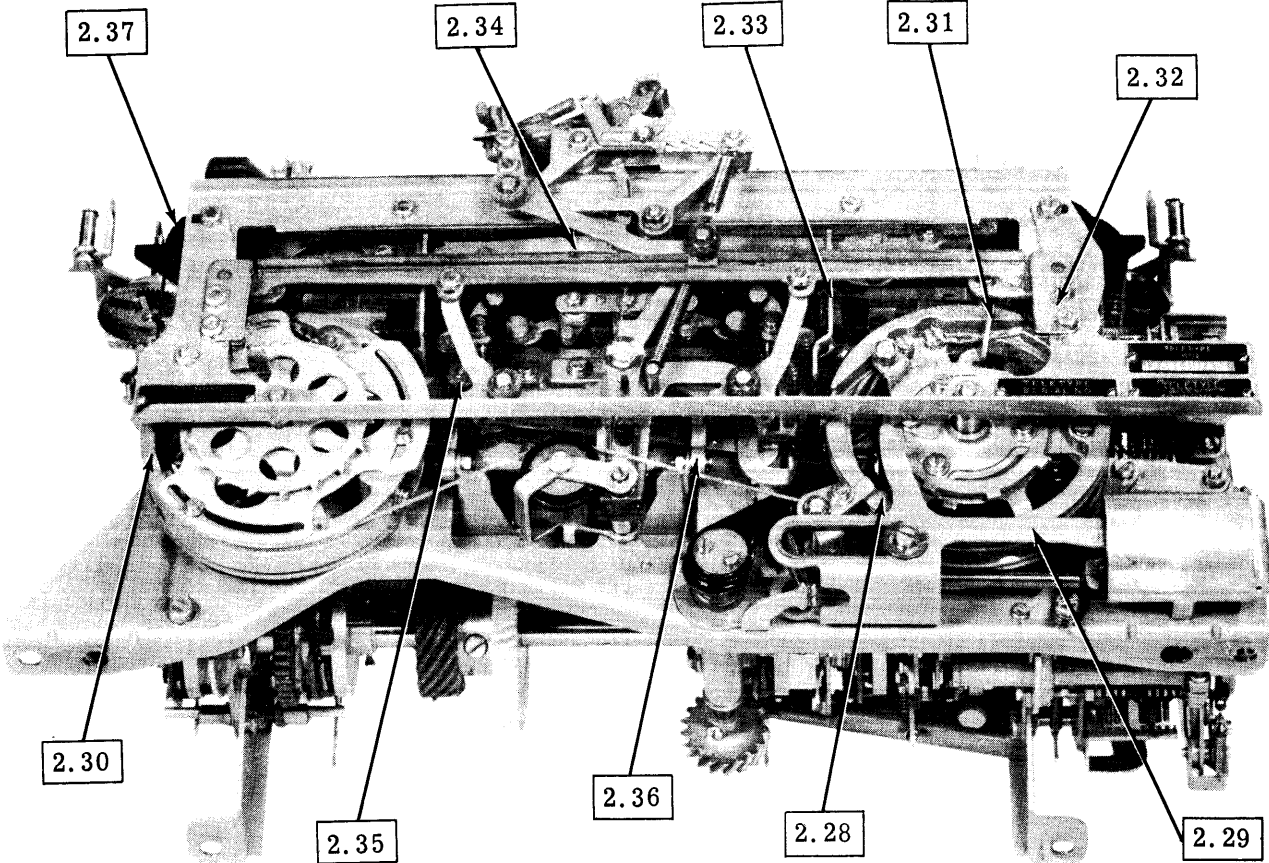

(Bottom Front View)

2.28 Spacing Drum Mechanism

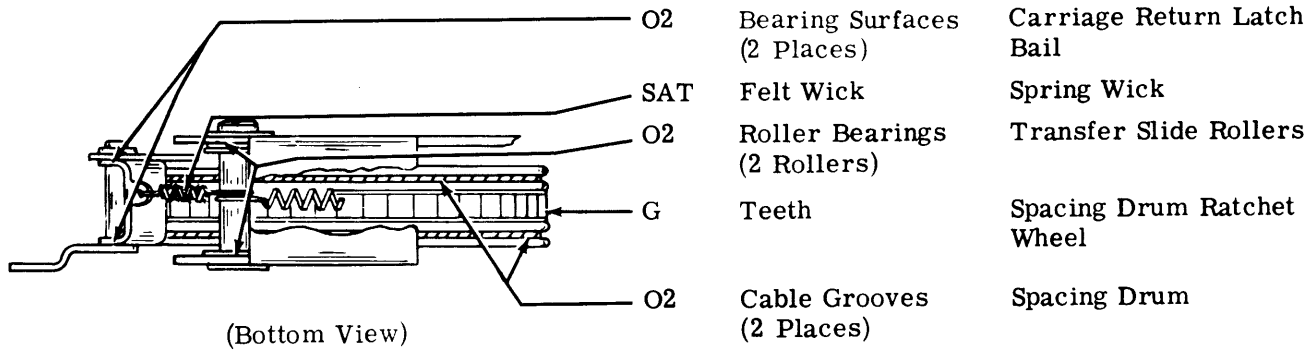
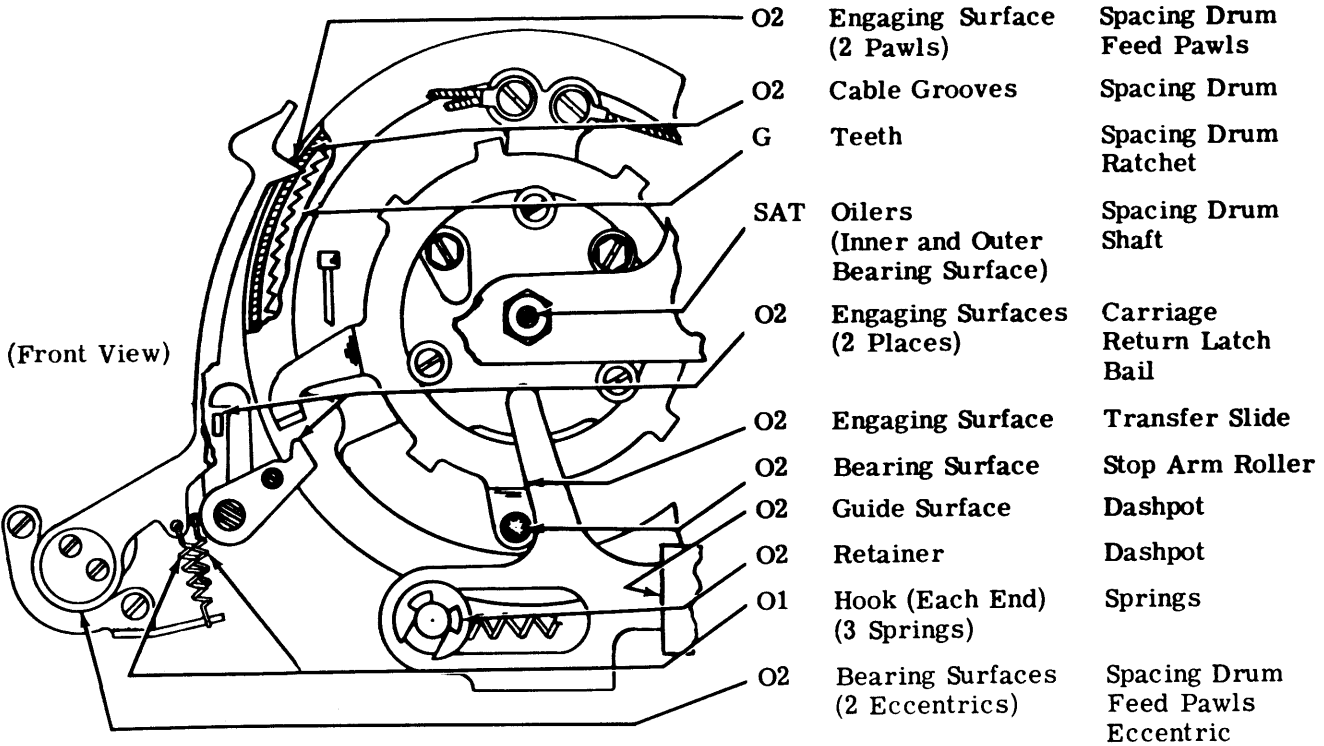

2.29 Dashpot Mechanism

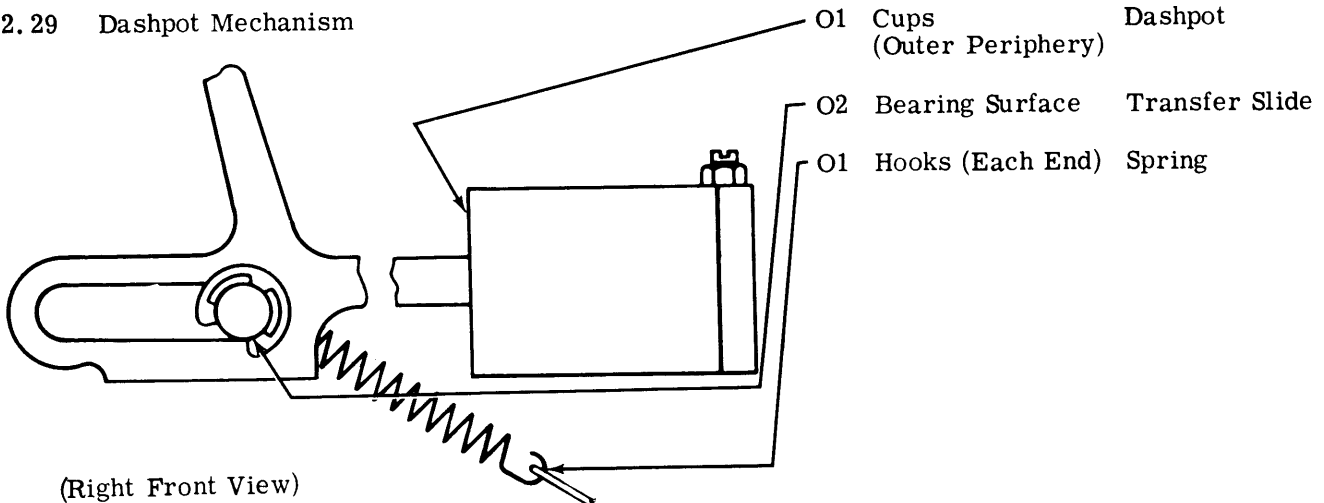

2.30 Carriage Return Mechanism

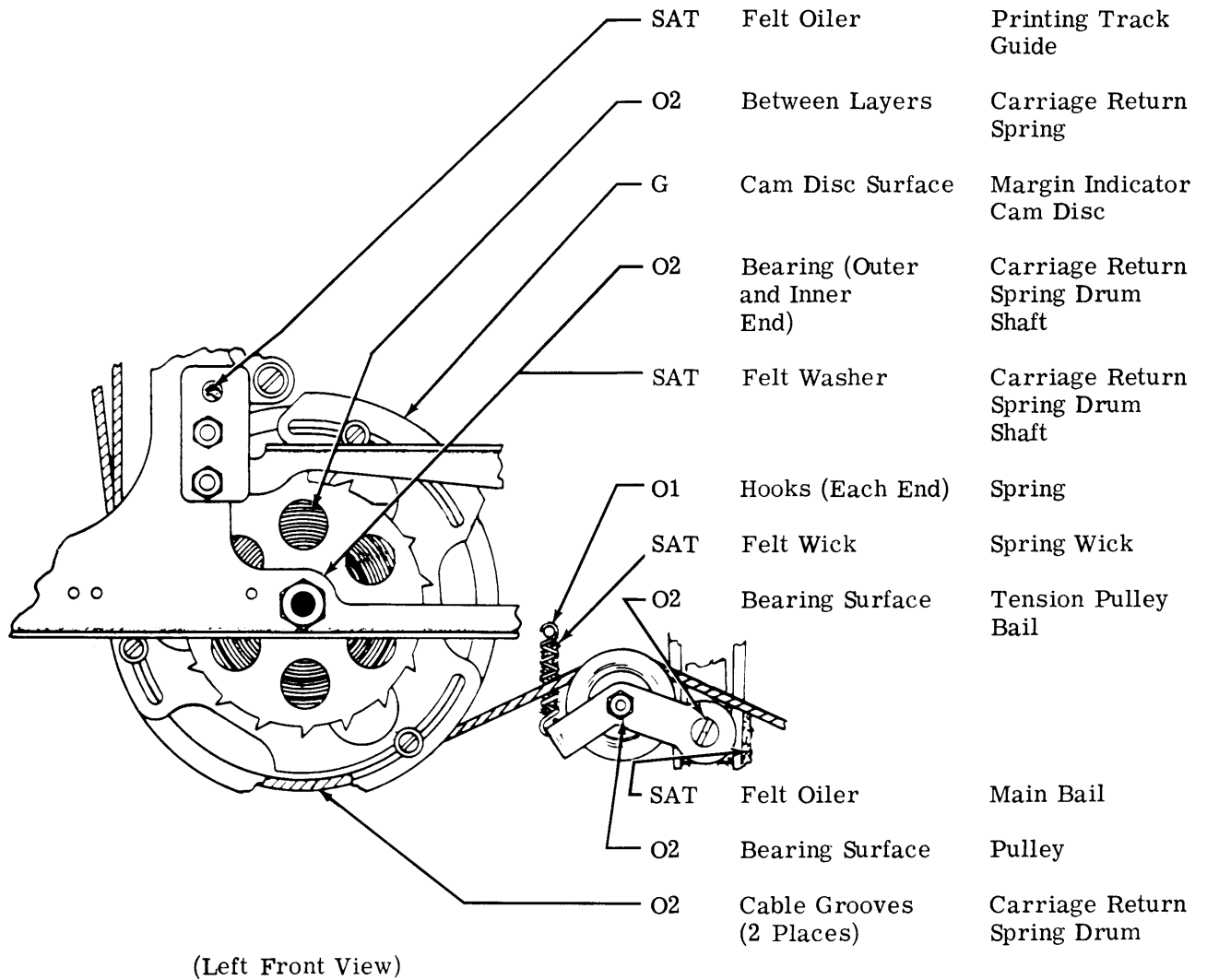

2.31 Spacing Drum Feed Mechanism

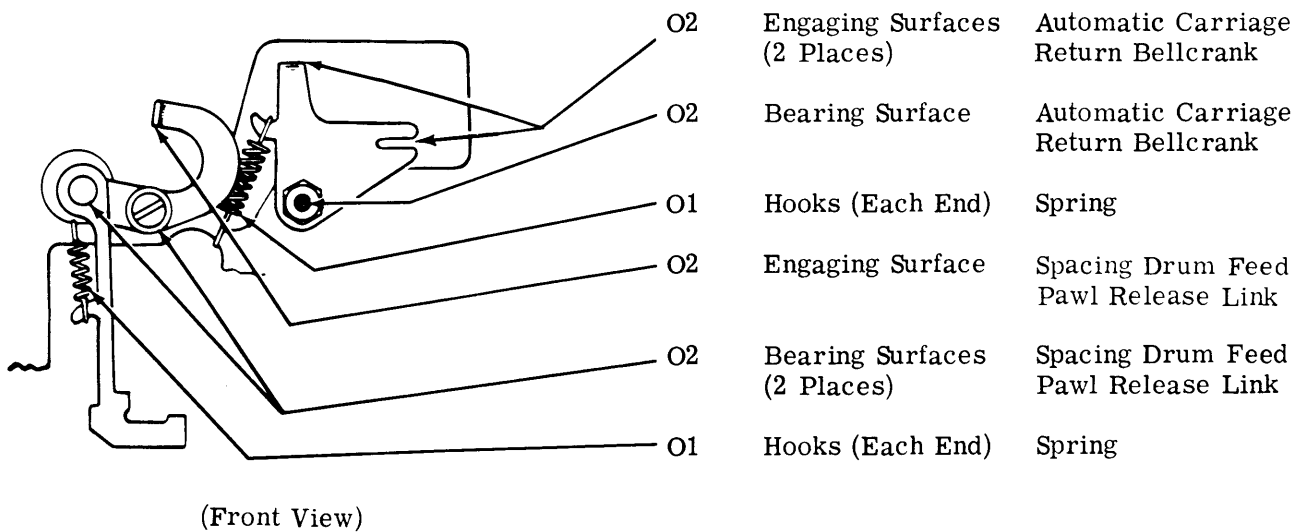

2.32 Track Guide Mechanism

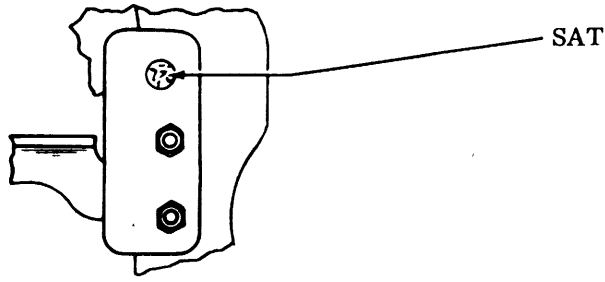

(Right Front View)

Felt Oiler

Printing Track Guide

2.33 Horizontal Positioning Mechanism

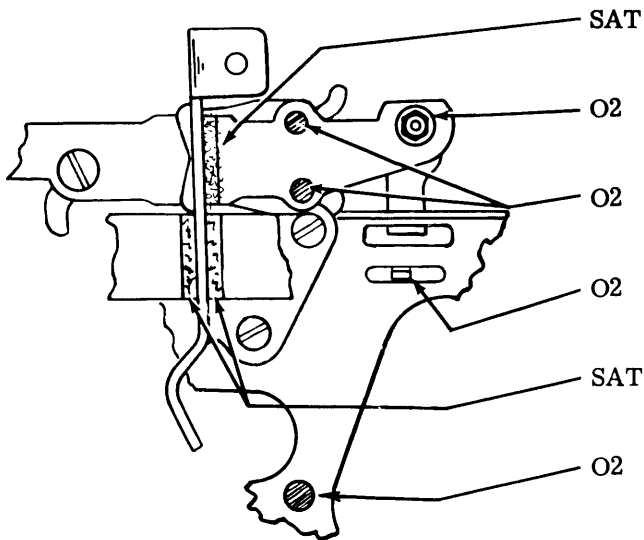

(Right Front View)

Felt Washer

Horizontal Reversing Slide

Engaging Surface

Horizontal Reversing Slide Shift Lever

Detent (2 Detents)

Detent Bail

Engaging Surface

Horizontal Reversing Slide Shift Lever

Felt Washers (2 Washers)

Oscillating Rail Shift Slide

Bearing Surface

Horizontal Reversing Slide Shift Lever

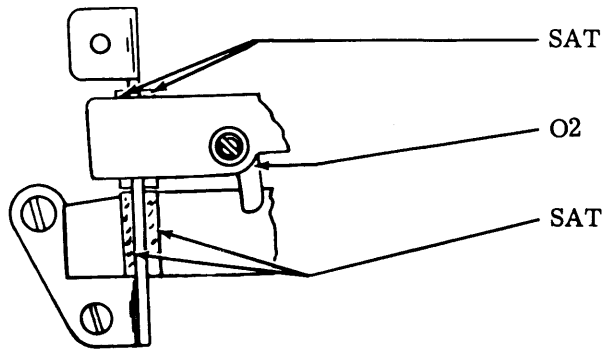

(Left Front View)

Felt Washers (2 Washers)

Horizontal Reversing Slide

Engaging Surfaces (2 Places)

Horizontal Reversing Slide Bracket

Felt Washers (2 Washers)

Oscillating Rail Shift Slide

2.34 Horizontal Positioning Mechanism (continued)

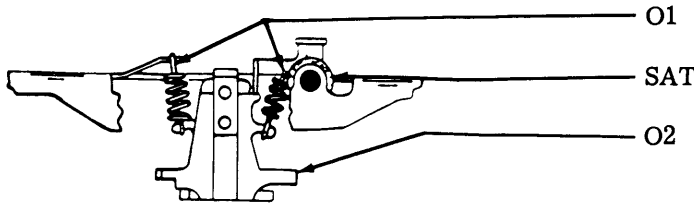

(Top View)

- | | | |
|-----|------------------------------|-------------------------------|
| O1 | Hooks (Each End) | Spring |
| SAT | Felt Washer | Codebar Bellcrank |
| O2 | Engaging Surfaces (3 Slides) | Horizontal Motion Stop Slides |

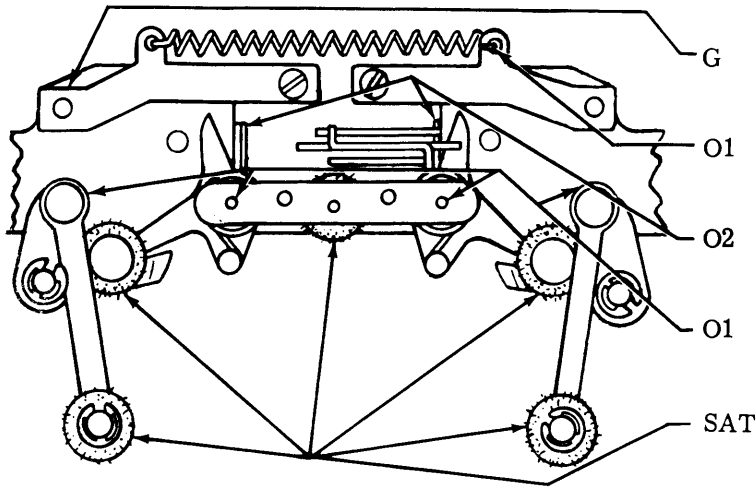

(Front View)

- | | | |
|-----|------------------------------|-----------------------------|
| G | Engaging Surfaces (2 Slides) | Shift Shock Absorber Slides |
| O1 | Hooks (Each End) | Shock Absorber Spring |
| O2 | Engaging Surfaces (2 Slides) | Decelerating Slides |
| O1 | Bearing Surfaces (4 Places) | Shift Slide Driver Links |
| SAT | Felt Washers (5 Washers) | Shift Slide Drive Links |

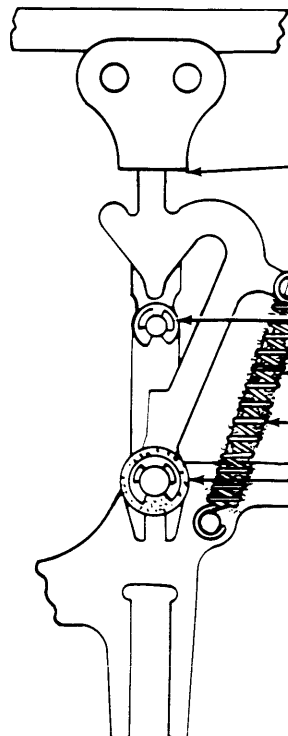

(Front View)

- | | | |
|-----|------------------|----------------------------------|
| O2 | Guiding Surface | Horizontal Positioning Locklever |
| O2 | Bearing Surface | Horizontal Locklever Arm Roller |
| SAT | Felt Wick | Spring Wick |
| O1 | Hooks (Each End) | Spring |
| SAT | Felt Washer | Horizontal Positioning Locklever |

2.35 Horizontal Positioning Drive Mechanism

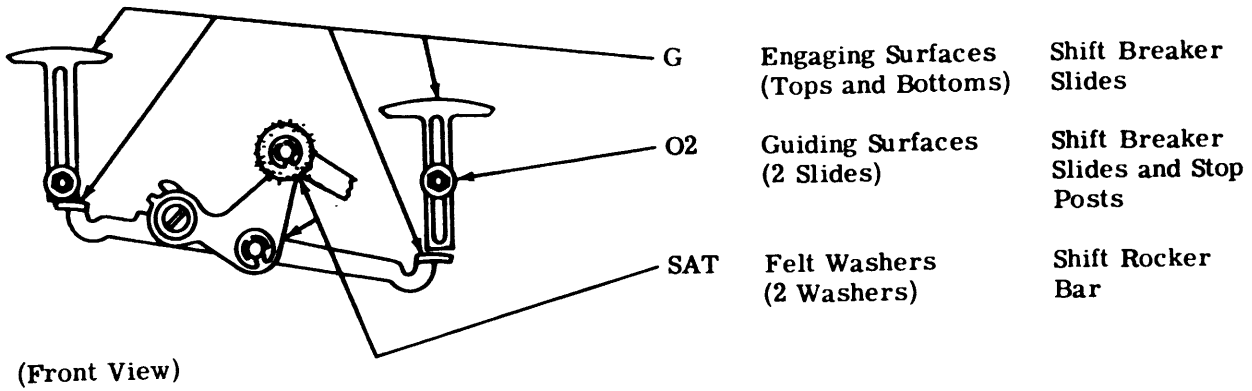

2.36 Shift Mechanism

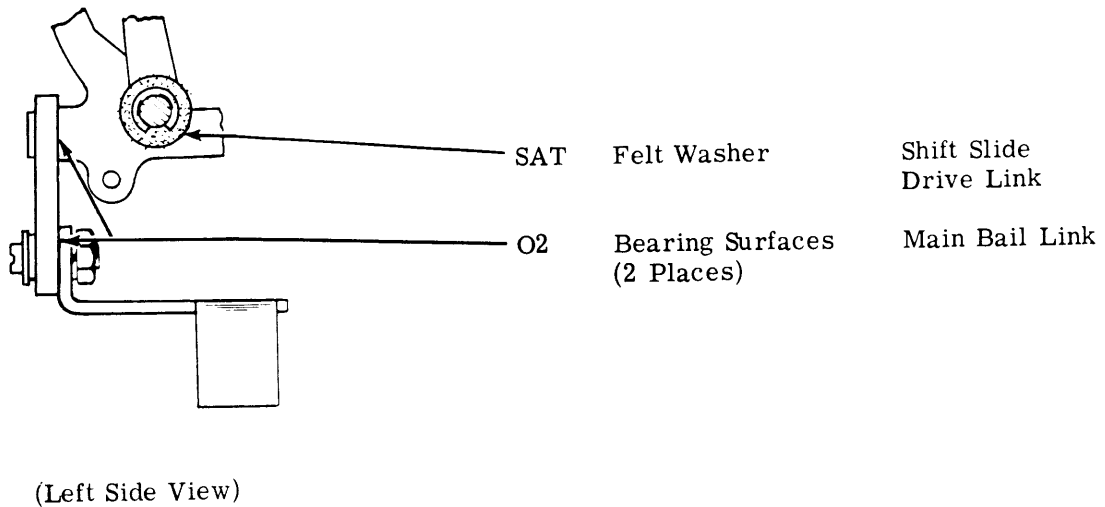
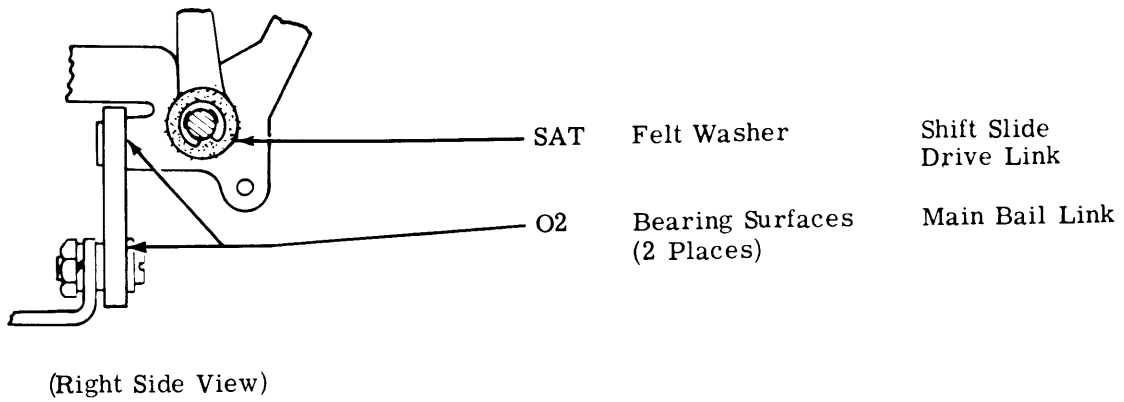

2.37 Oscillating Mechanism

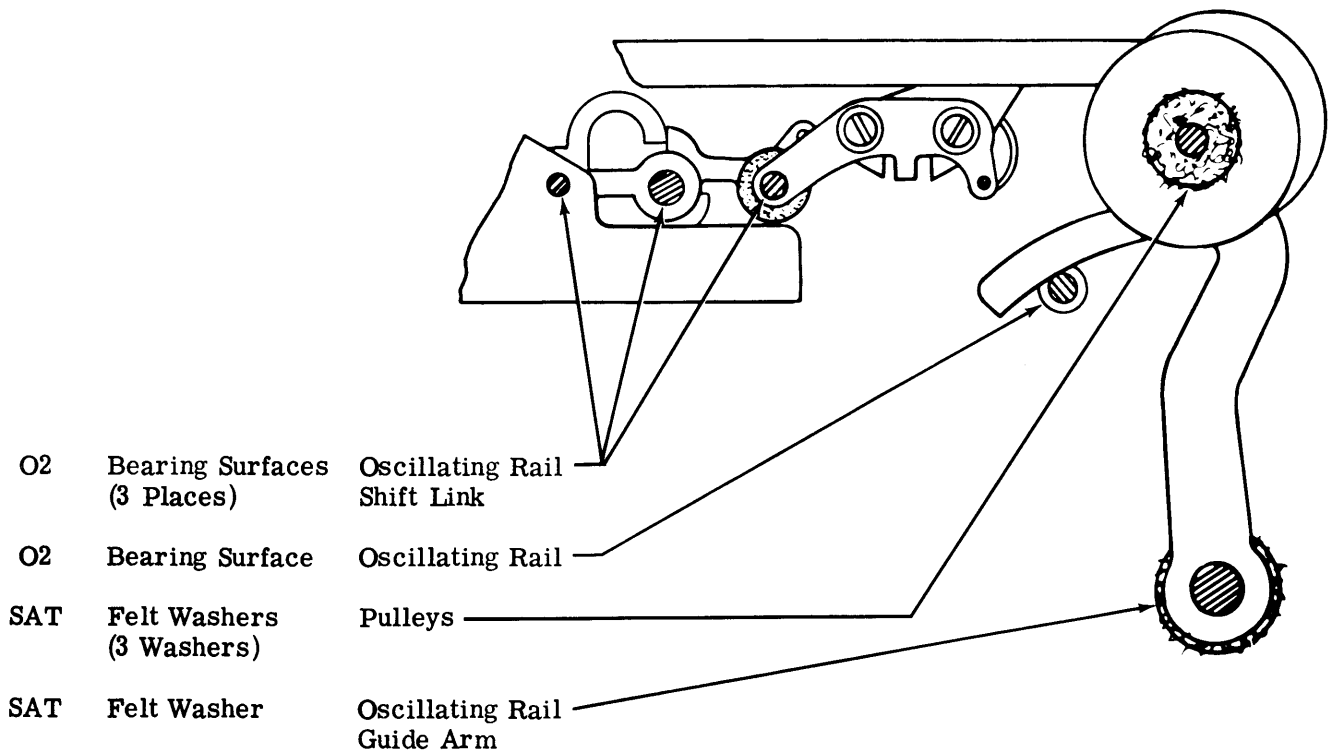
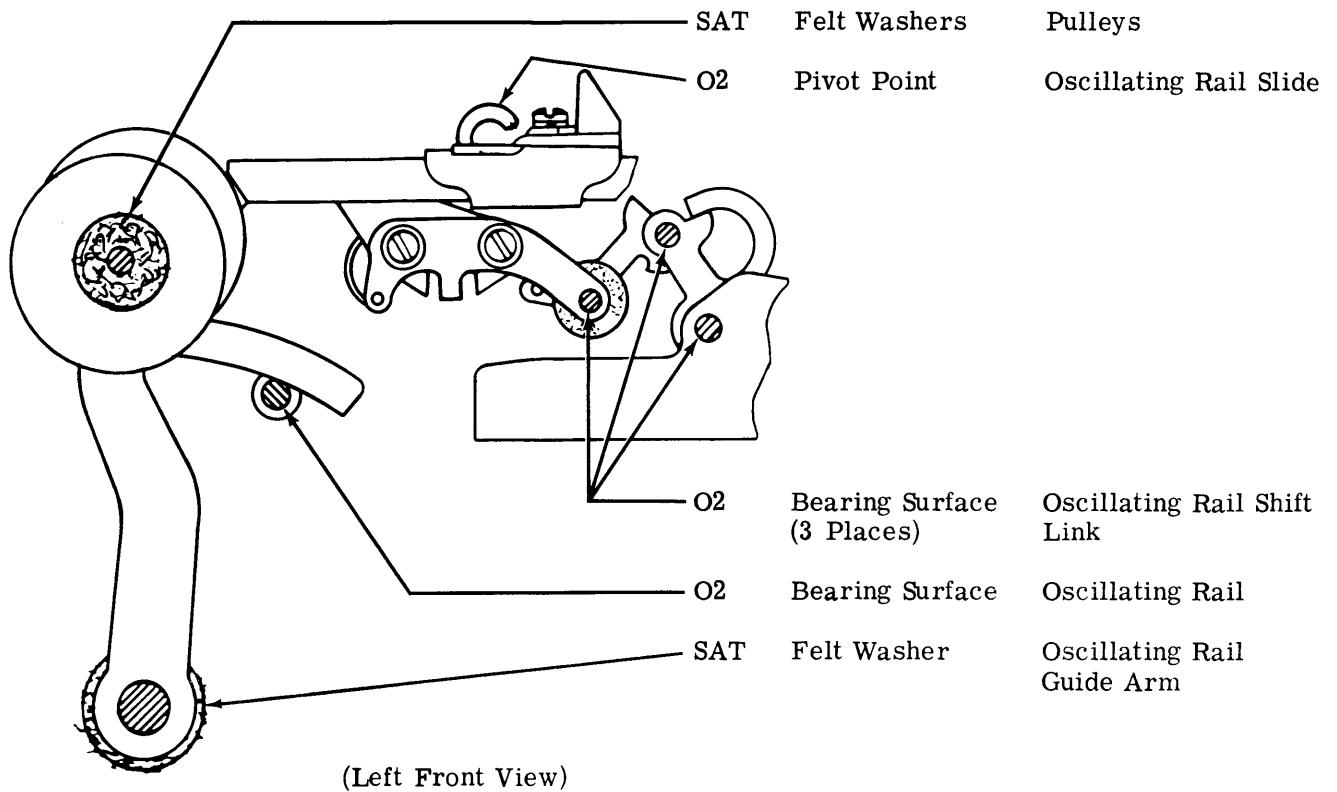

(Right Front View)

2.38 Main Shaft Area

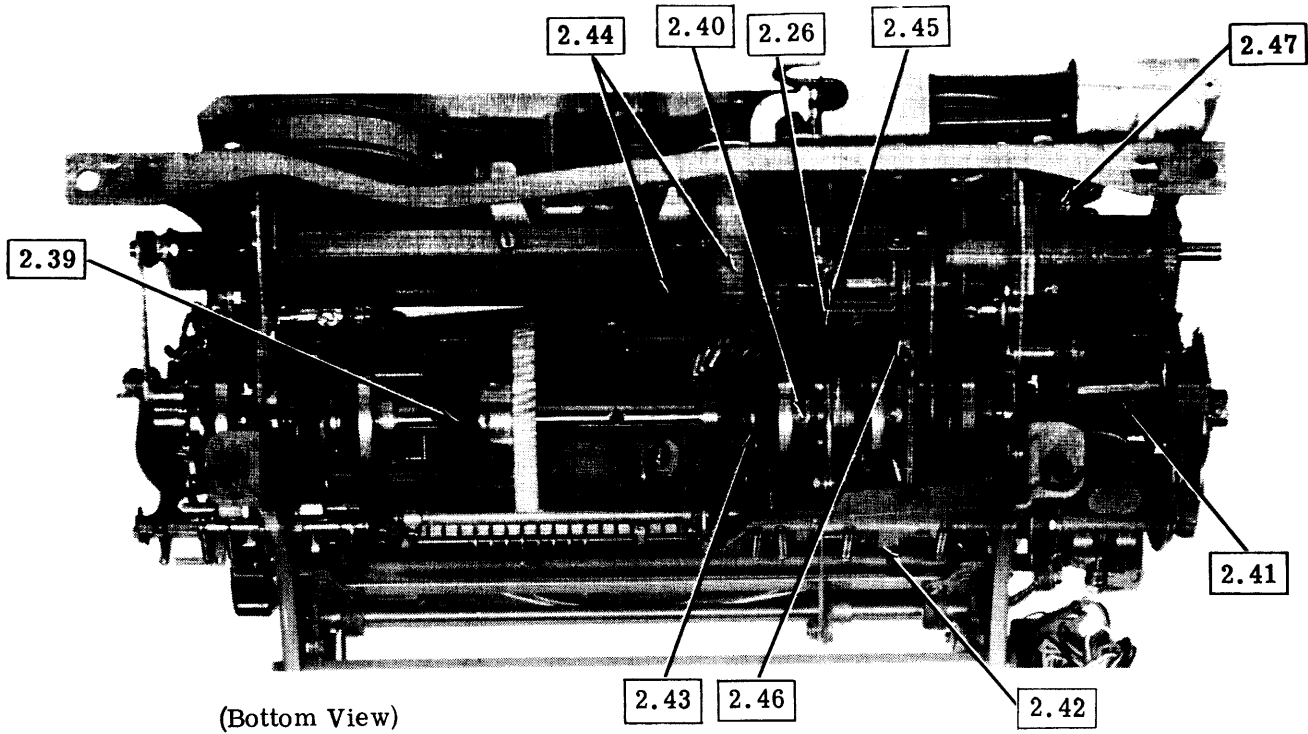

2.39 Main Shaft (Clutches, Gears, etc)

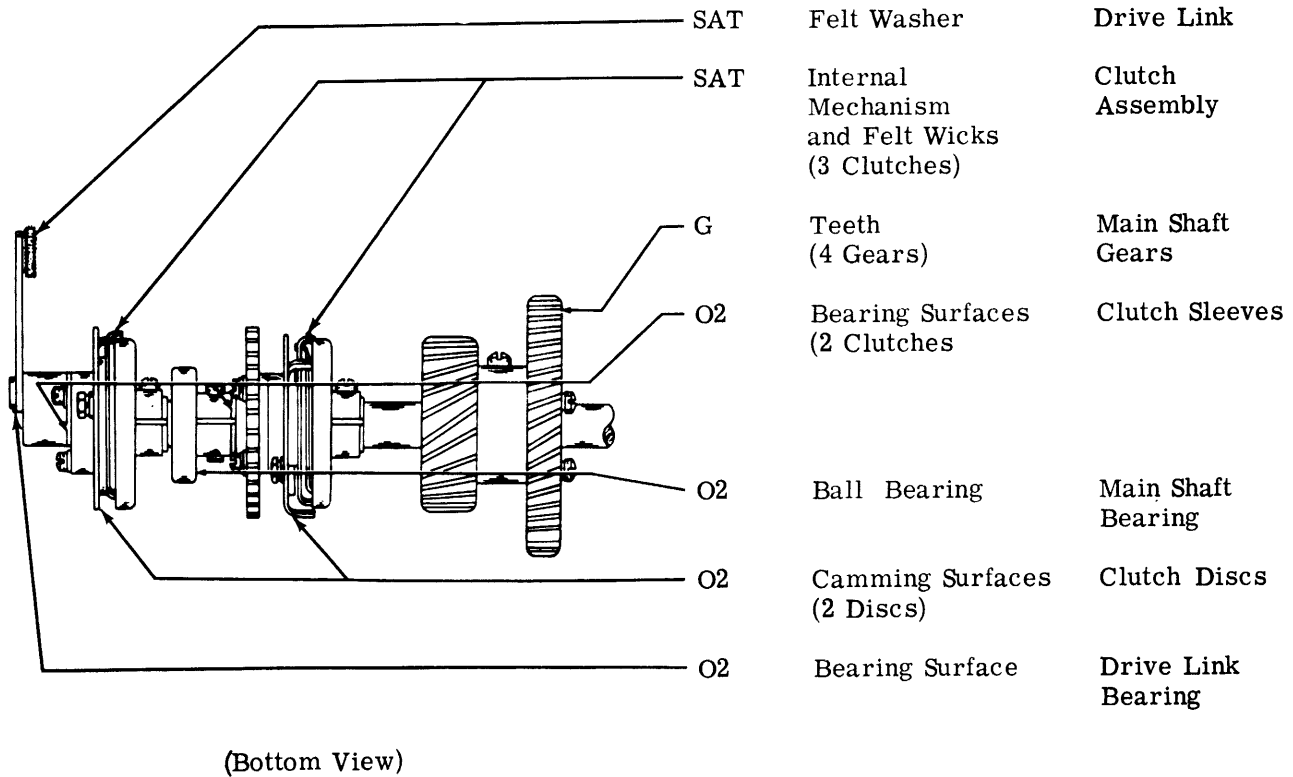

2.40 Main Shaft (Clutches, Gears, etc) (continued)

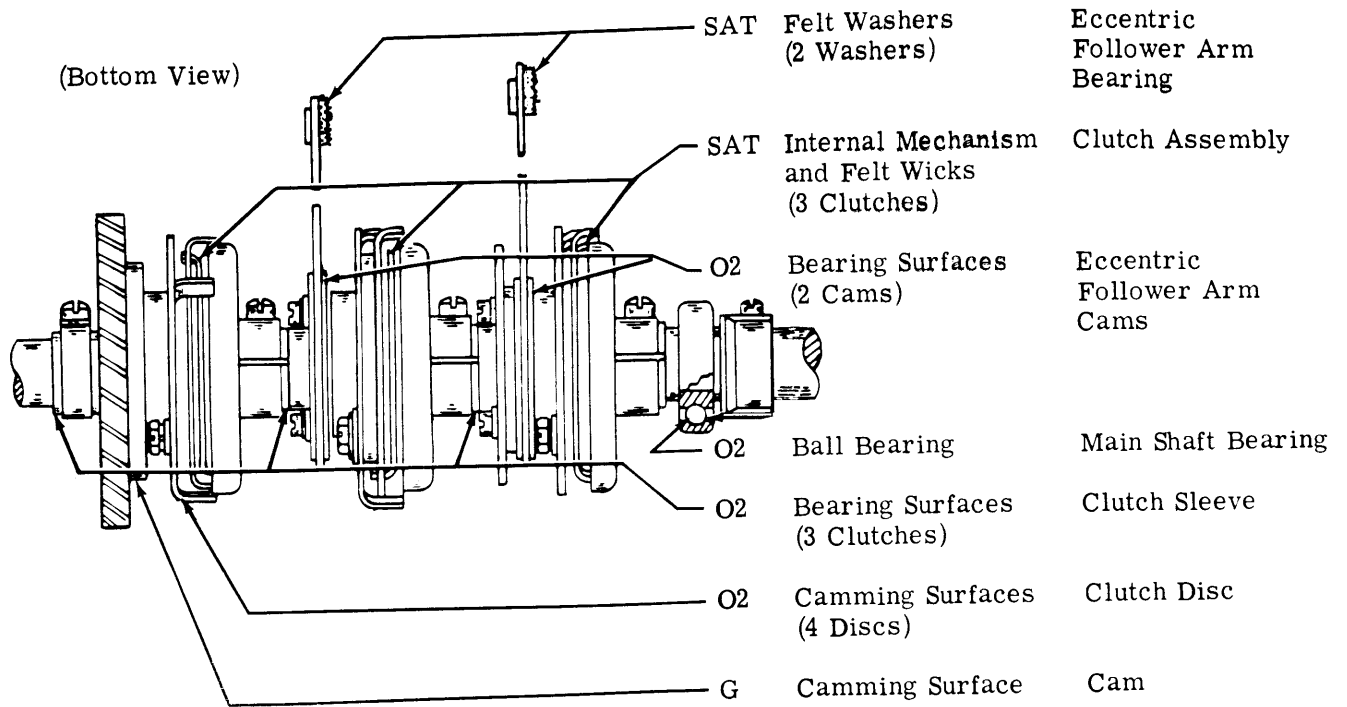

2.41 Selector Cam Clutch Assembly

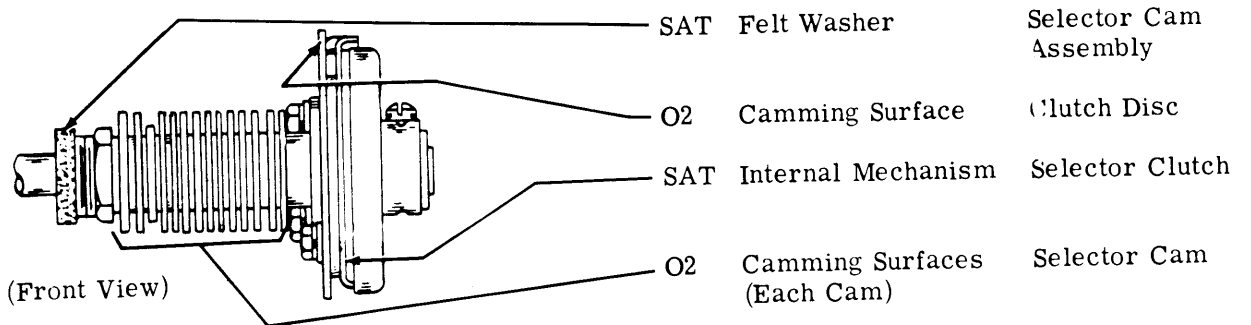

2.42 Trip Shaft Mechanism

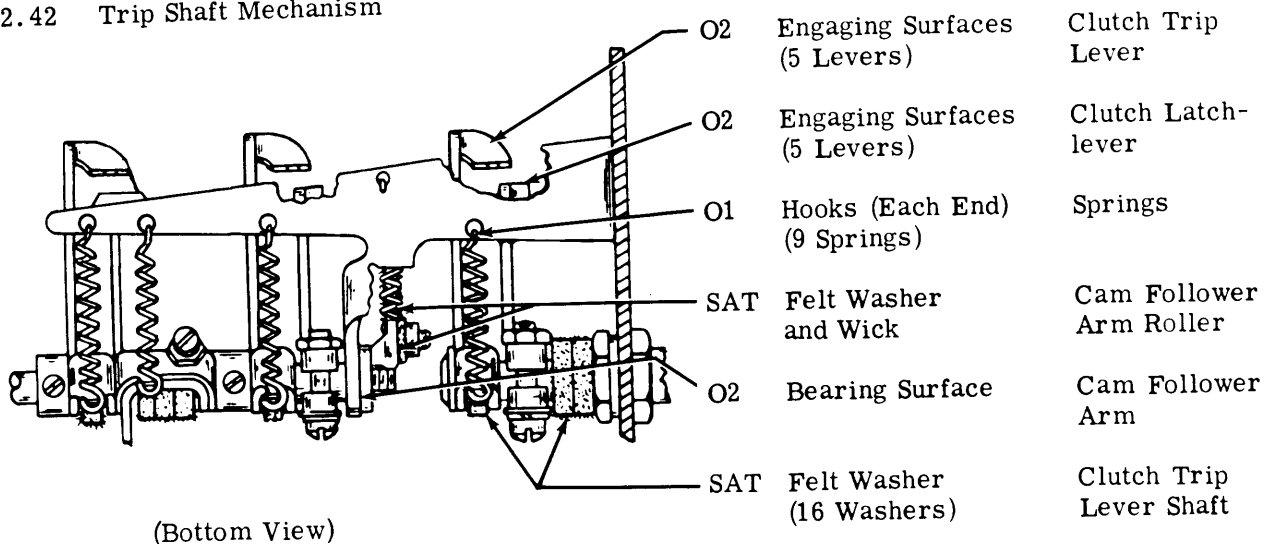

SECTION 574-220-701TC

2.43 Spacing Clutch Trip Cam Mechanism

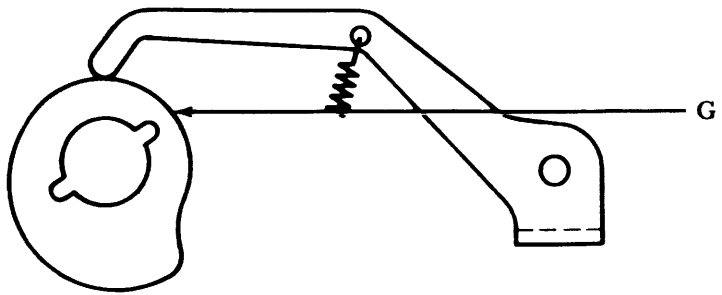

(Right Side View)

Camming Surface	Spacing Clutch Trip Cam
-----------------	-------------------------

2.44 Spacing Mechanism

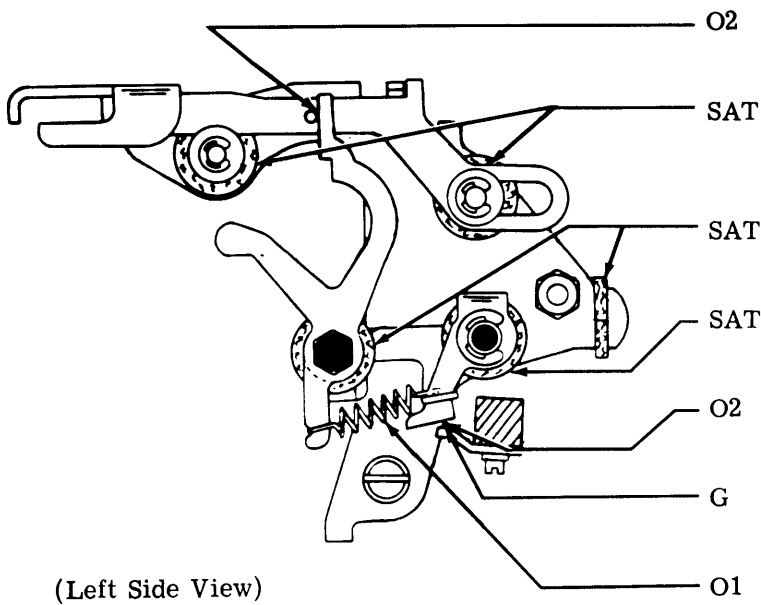

(Left Side View)

O2	Engaging Surfaces	Spacing Trip Lever
SAT	Felt Washers (2 Washers)	Spacing Suppression Slide
SAT	Felt Washers (2 Washers)	Spacing Trip Lever
SAT	Felt Washer	Spacing Trip Lever Bail Shaft
O2	Engaging Surface	Spacing Trip Lever Bail
G	Engaging Surface	Rocker Shaft Cam Place
O1	Hooks (Each End) (2 Springs)	Spring

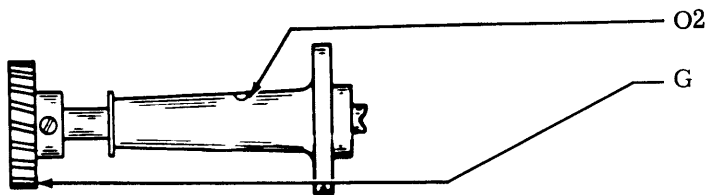

(Bottom View)

O2	Oil Hole	Spacing Shaft
G	Teeth	Spacing Shaft Gear

2.45 Spacing Mechanism (continued)

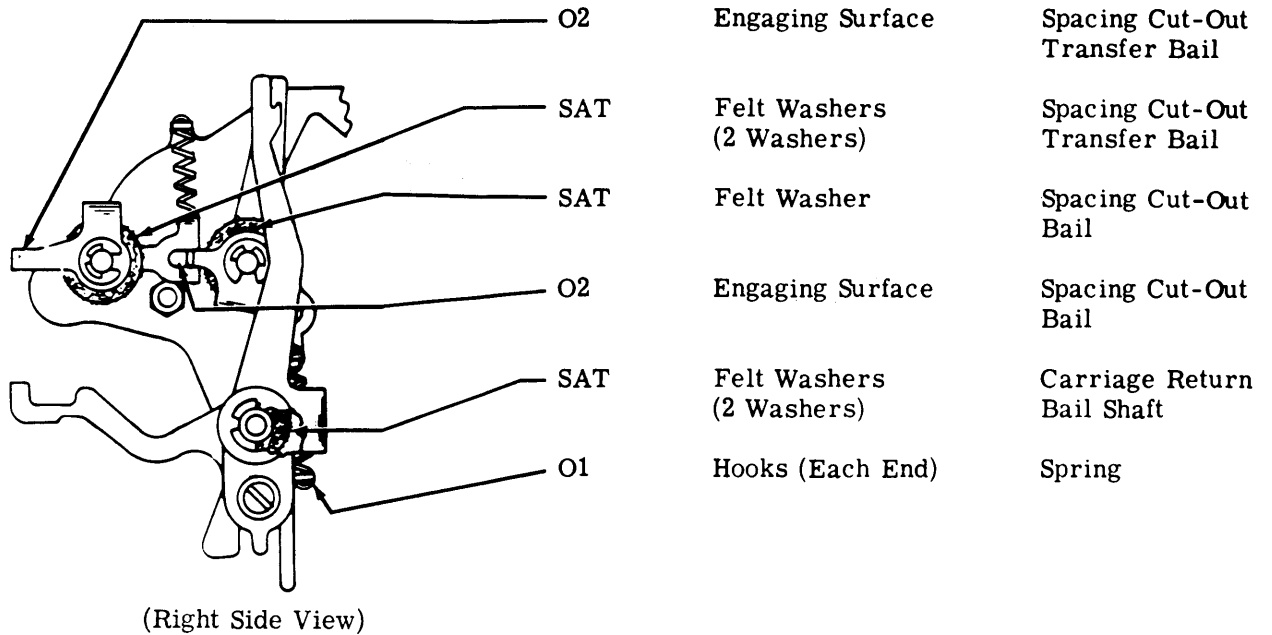

2.46 Shift Selector Mechanism

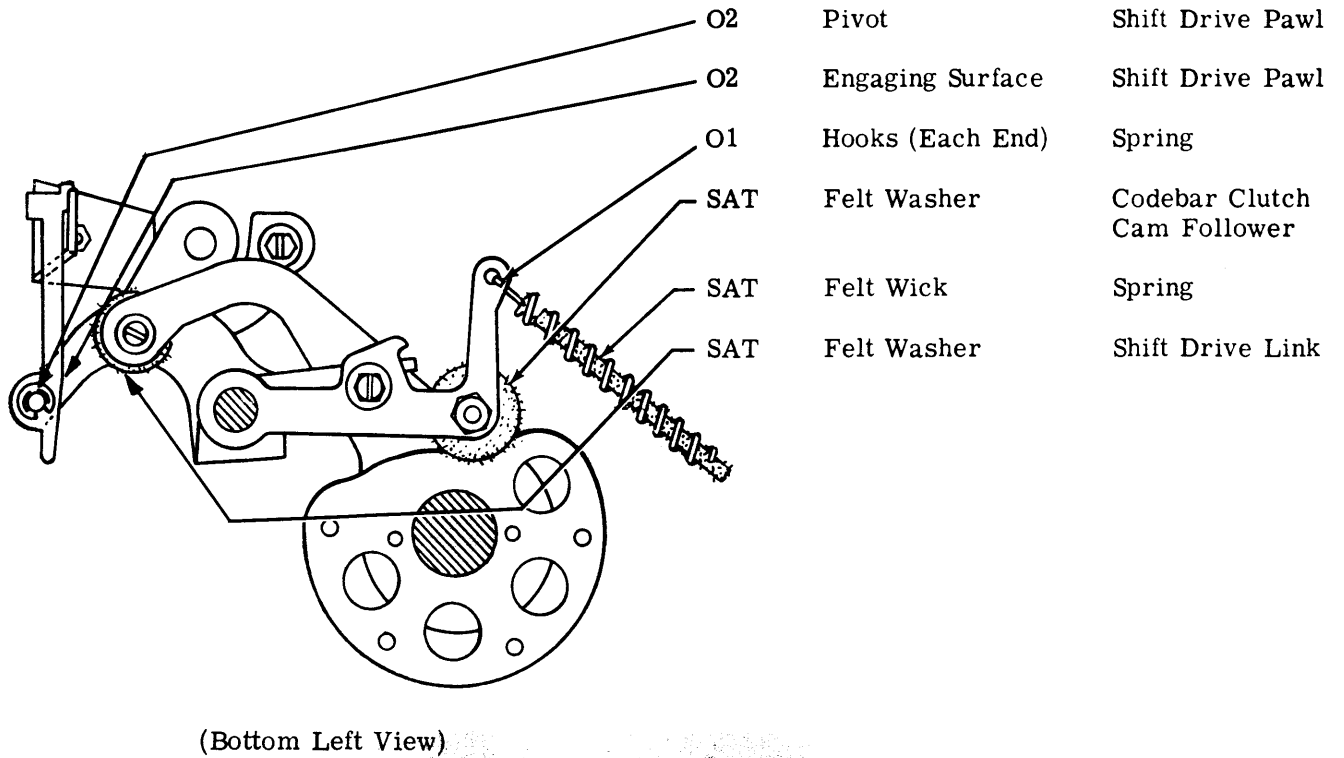

2.47 Shift Selector Mechanism (continued)

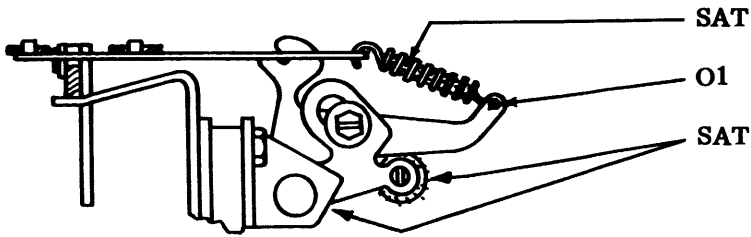

(Rear View)

- SAT Felt Wick Spring
- O1 Hooks (Each End) Spring
- SAT Felt Washers (2 Washers) Shift Selector Arm Bell-crank

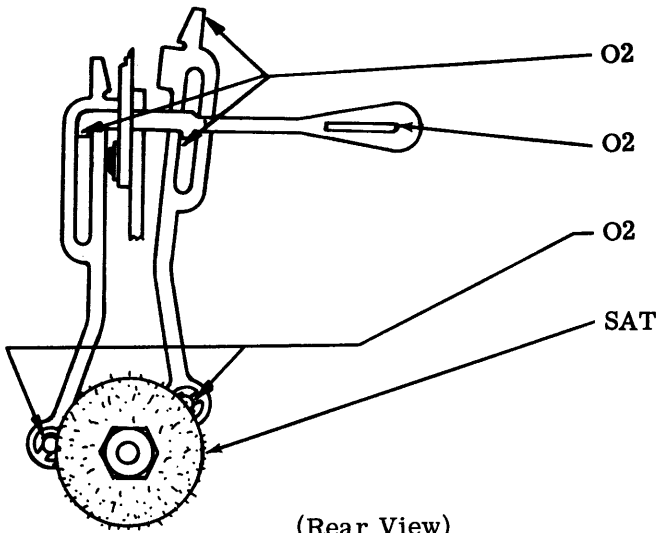

(Rear View)

- O2 Engaging Surfaces (3 Places) Shift Pawl
- O2 Guide Surface Shift Pawl Link
- O2 Pivots (2 Places) Shift Pawl
- SAT Felt Washer Shift Pawl

2.48 Line Feed Area

(Rear View)

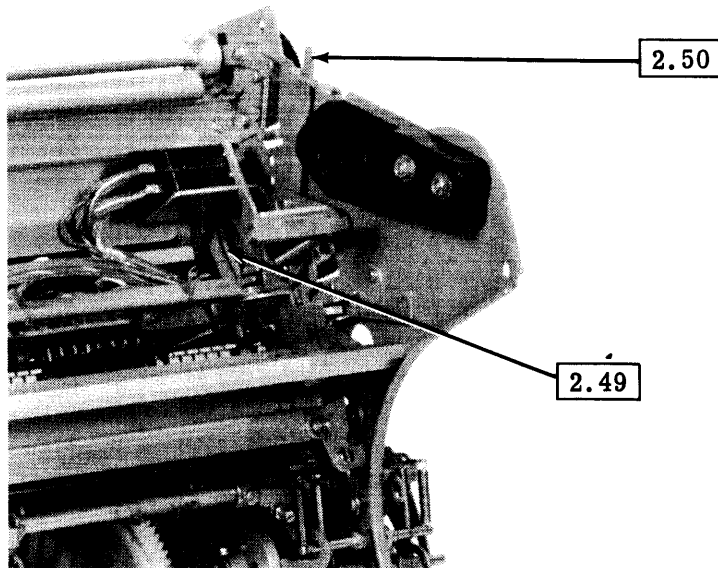

2.49 Line Feed Mechanism (Friction Feed)

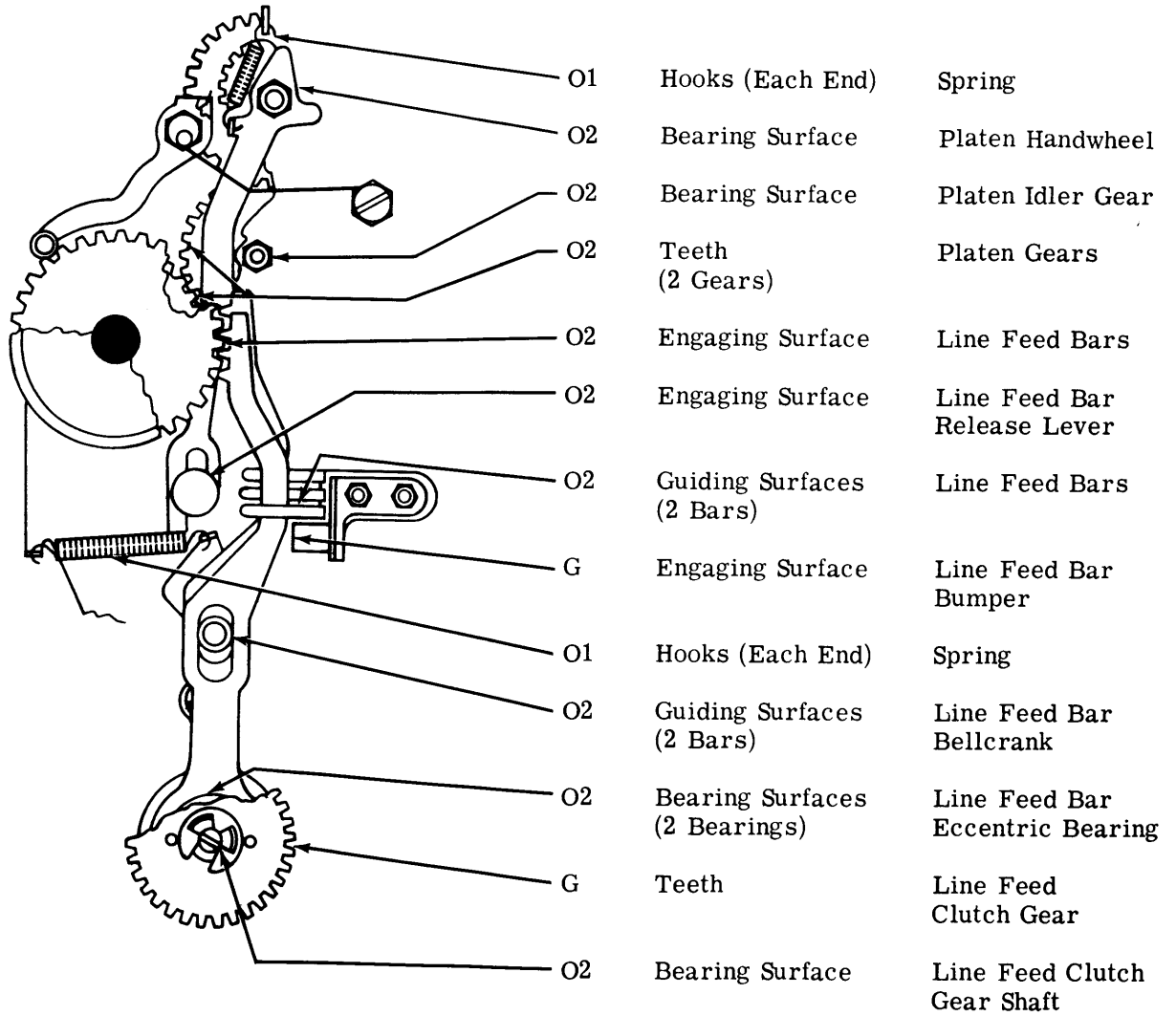

(Right Rear View)

SECTION 574-220-701TC

2.50 Single-Double Line Feed Mechanism

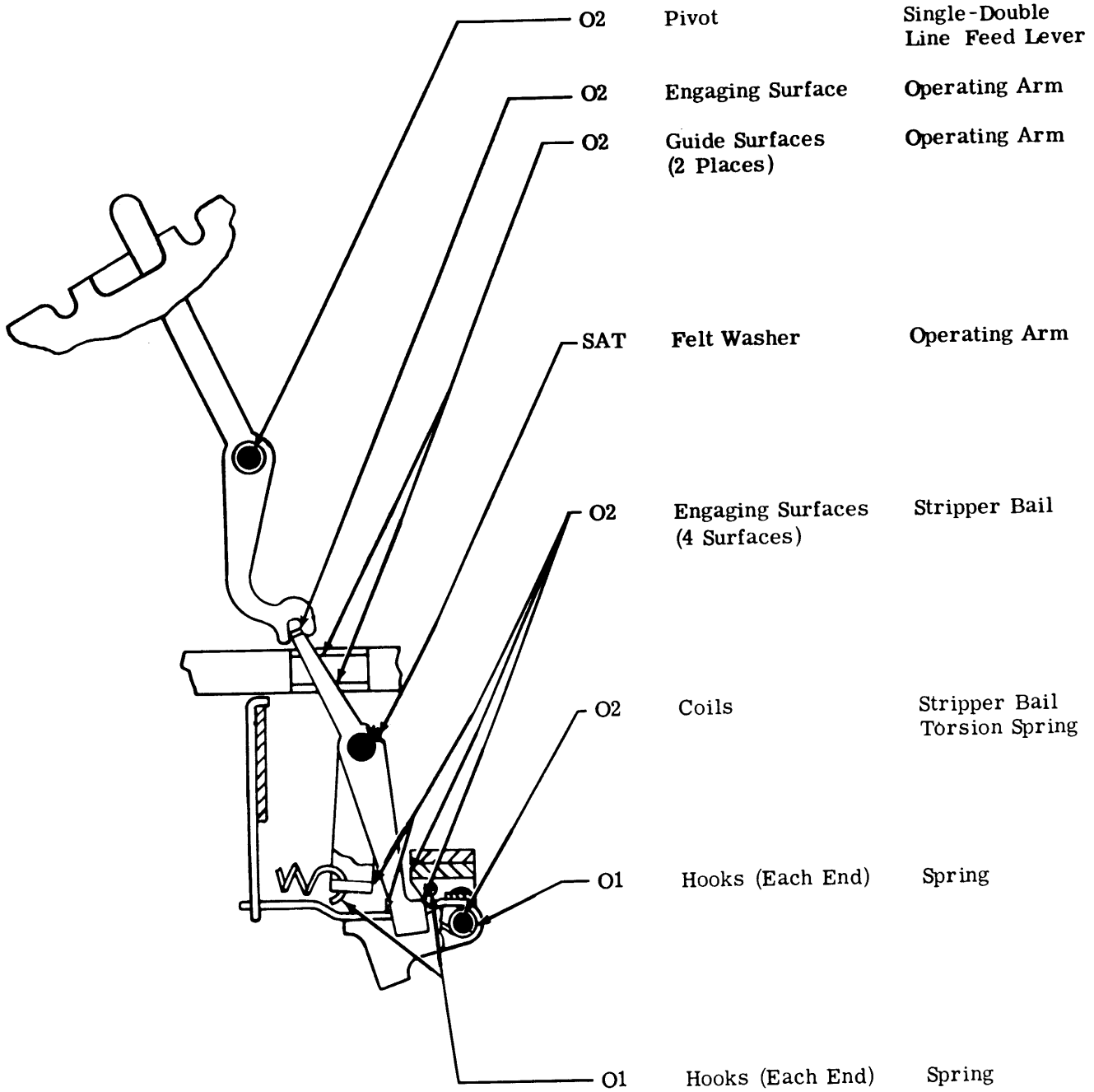

(Left Side View)

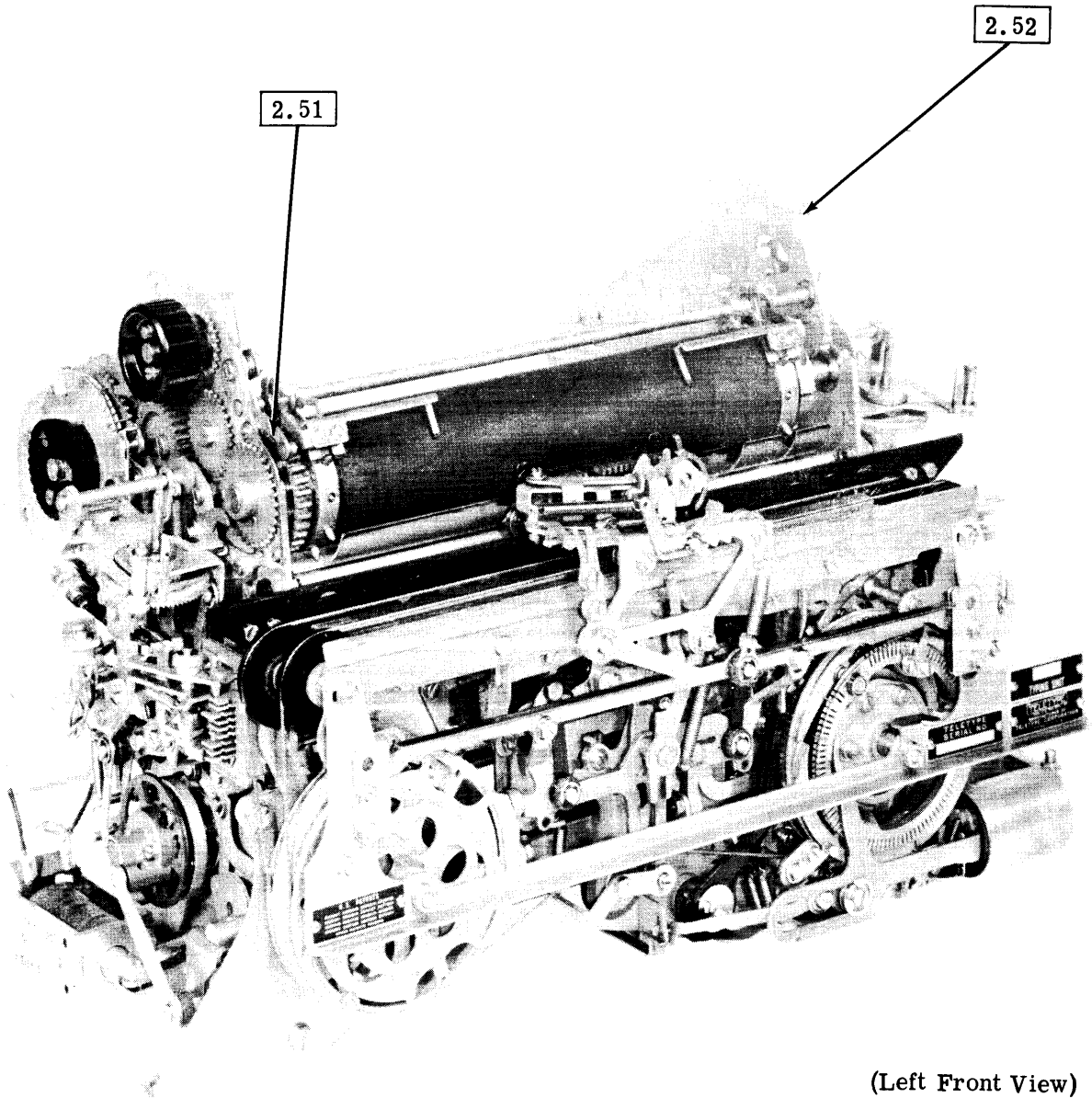
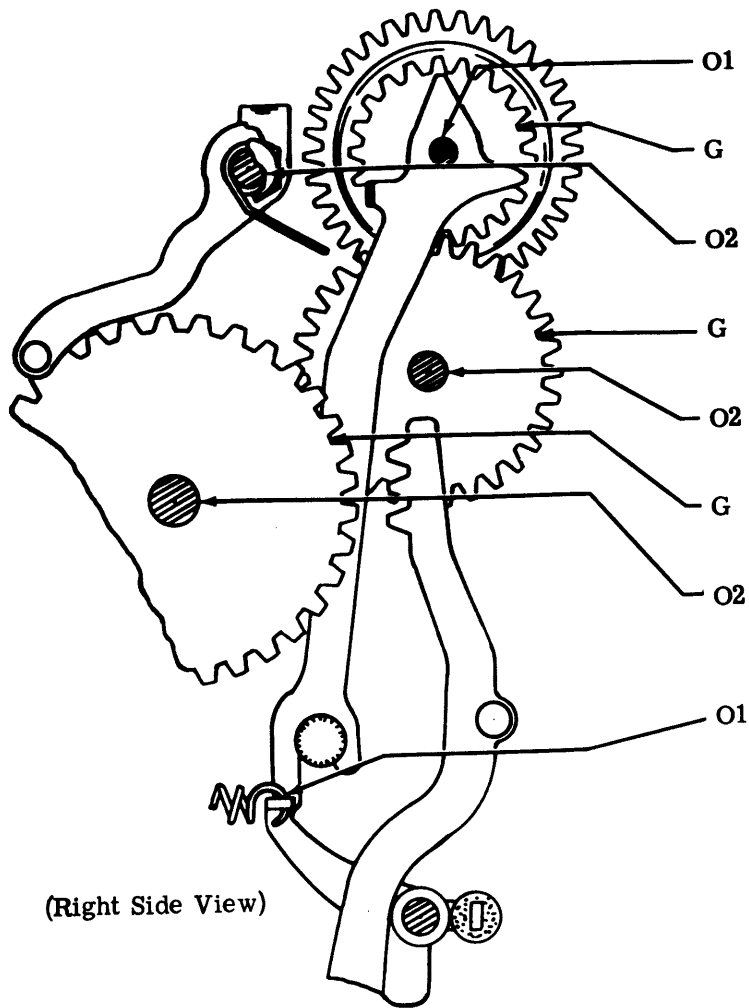

Figure 3 - 35 Typing Unit (Sprocket Feed)

2.51 Line Feed Mechanism (Sprocket Feed)



- | | | |
|----|--------------------------------|--------------------|
| O1 | Bearing Surface | Handwheel Gear |
| G | Teeth | Handwheel Gear |
| O2 | Bearing Surface | Platen Detent Bail |
| G | Teeth | Idler Gear |
| O2 | Bearing Surface | Idler Gear |
| G | Teeth | Platen Gear |
| O2 | Bearing Surfaces
(2 Places) | Platen Gear |
| O1 | Hooks (Each End) | Spring |

2.52 Sprocket Feed Paper Mechanism

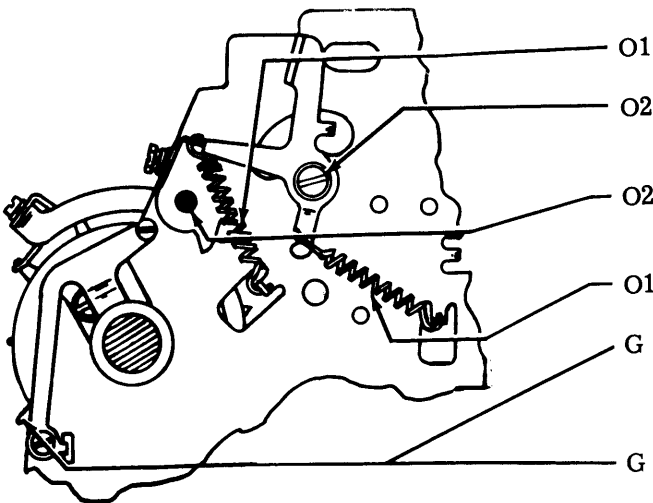

- | | | |
|----|--|------------------------------|
| O1 | Hooks (Each End) | Spring |
| O2 | Pivot
(2 Places) | Guide Bracket
Latch |
| O2 | Pivots
(2 Places) | Guide Bracket
Shaft |
| O1 | Hooks (Each End) | Spring |
| G | Pack Pin and
Spring Cavaties
(22 Places) | Sprocket With
Steel Pins |
| G | Light Coat
Do Not Pack
With Grease | Sprocket With
Delrin Pins |

3. VARIABLE FEATURES

3.01 Typing Unit (Sprocket Feed)

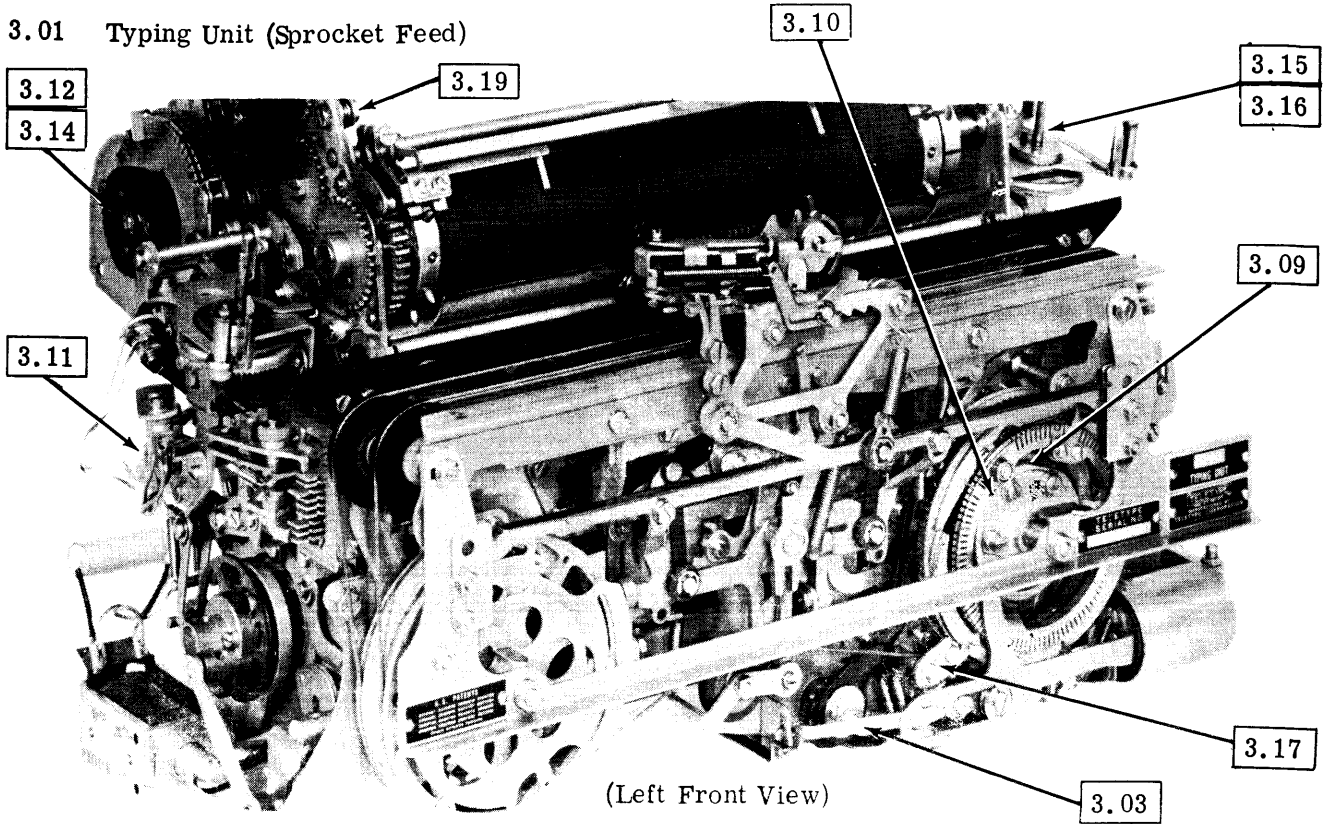

3.02 Horizontal Tabulator Area

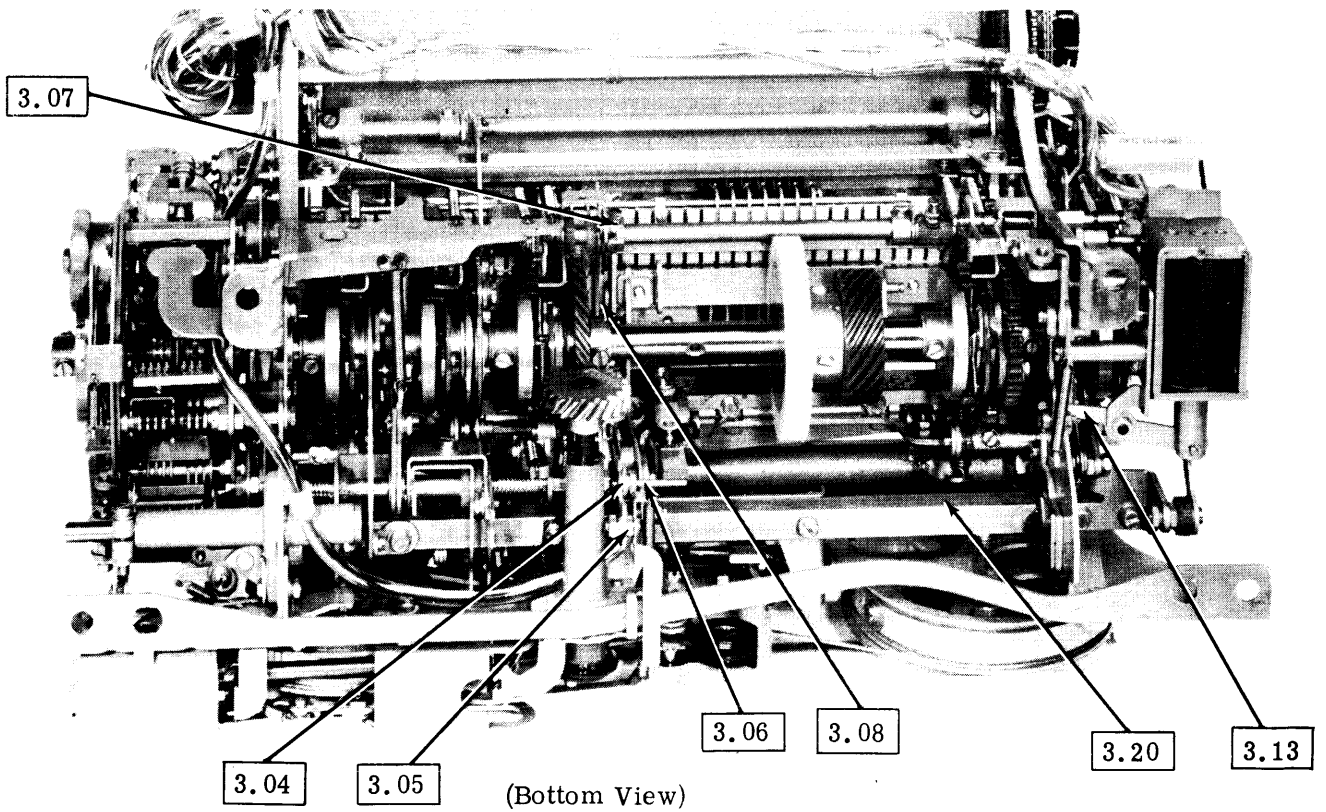

SECTION 574-220-701TC

3.03 Horizontal Tabulator — Blocking Lever

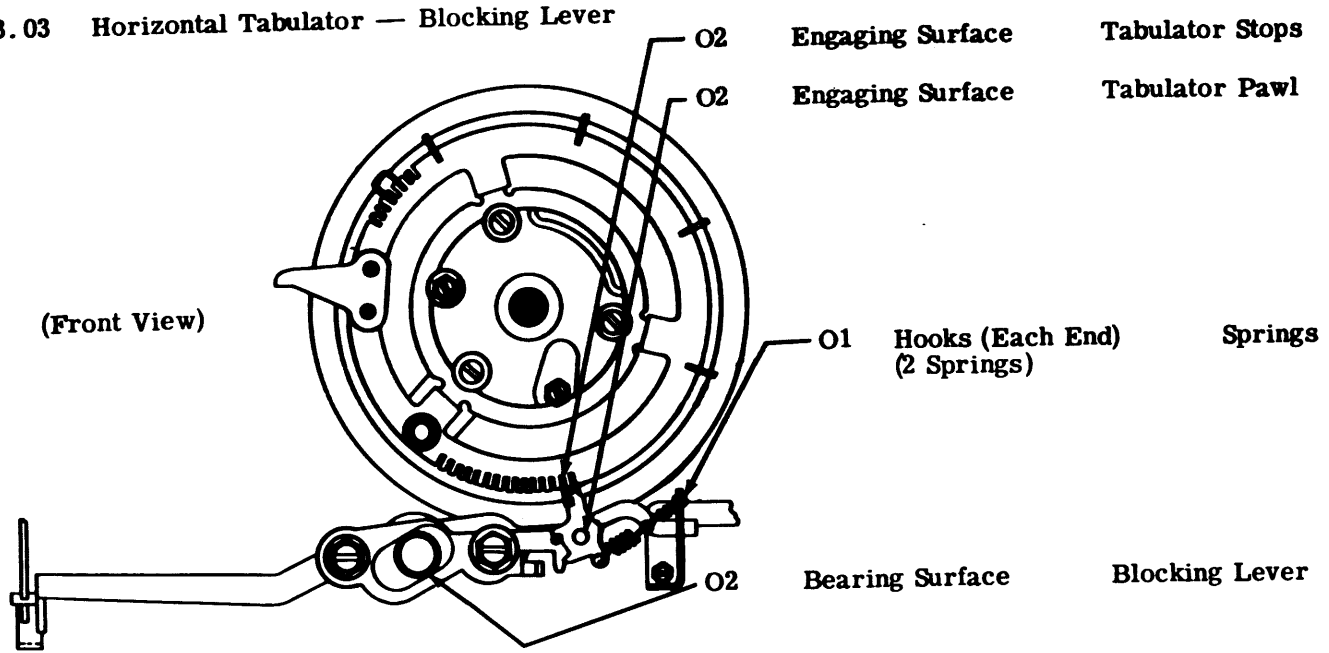

3.04 Horizontal Tabulator — Slide Arm

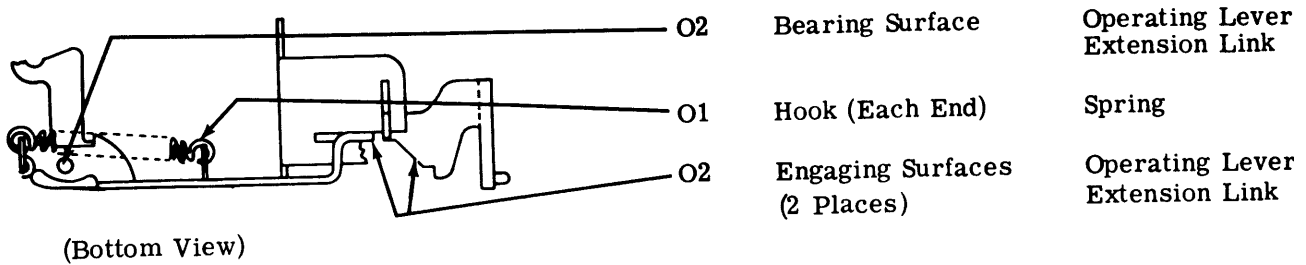

3.05 Horizontal Tabulator — Operating Lever

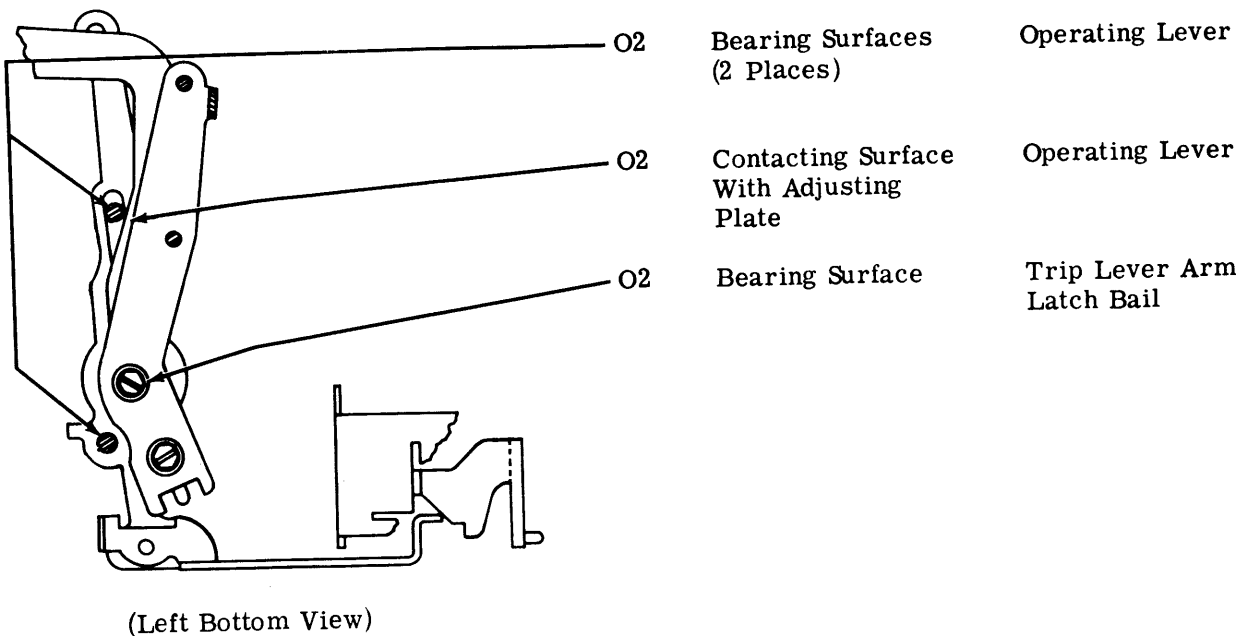

3.06 Horizontal Tabulator — Latch Bail

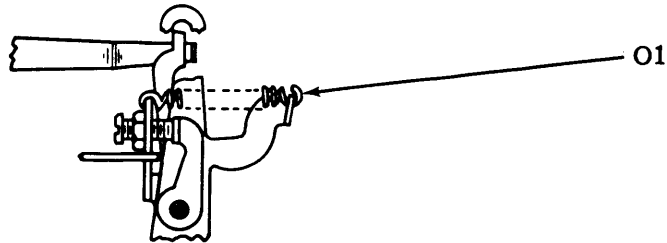

(Left Side View)

O1	Hooks (Each End)	Latch Bail Spring
----	------------------	-------------------

3.07 Horizontal Tabulator — Operating Lever (continued)

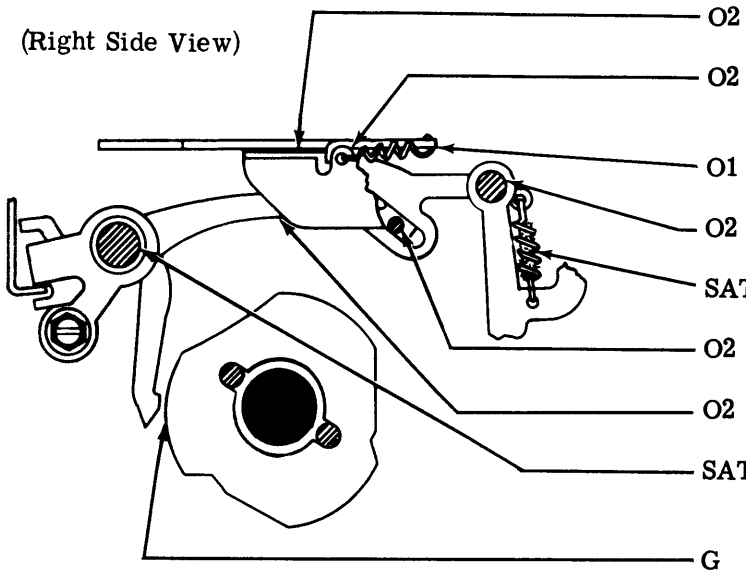

(Right Side View)

O2	Guide Surface	Operating Lever
O2	Contact With Slide Arm	Operating Lever
O1	Hooks (Each End)	Slide Arm Spring
O2	Bearing Surface	Operating Lever
SAT	Felt Wick	Spring
O2	Camming Surface	Operating Lever
O2	Contact Surface	Operating Lever
SAT	Felt Washers	Stripper Bail Shaft
G	Camming Surface	Spacing Clutch Restoring Cam

3.08 Horizontal Tabulator — Intermediate Bail

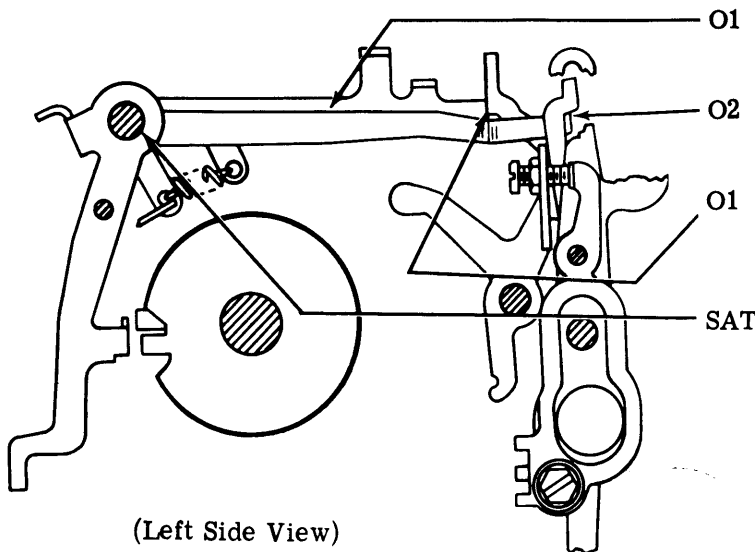

(Left Side View)

O1	Contact Surface Trip Lever Arm	Intermediate Bail
O2	Contact Surface	Spacing Trip Lever Arm
O1	Contact Surface Spacing Trip Lever	Intermediate Bail
SAT	Felt Washer	Trip Lever Arm Shaft

SECTION 574-220-701TC

3.09 Horizontal Tabulator — Bail Extension Arm

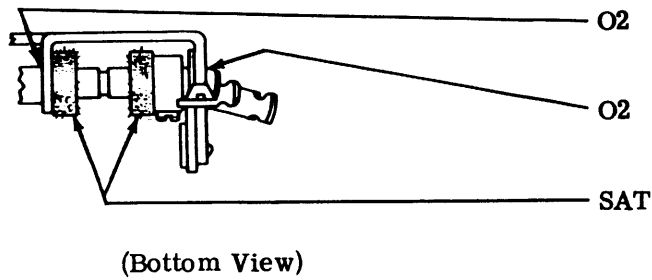

- | | | |
|-----|--------------------------|-------------------------------|
| O2 | Bearing Surface | Spacing Cut-Out Transfer Bail |
| O2 | Contact Surface | Spacing Cut-Out Transfer Bail |
| SAT | Felt Washers (2 Washers) | Transfer Bail Stud |

3.10 Spacing Cut-Out Transfer Bail

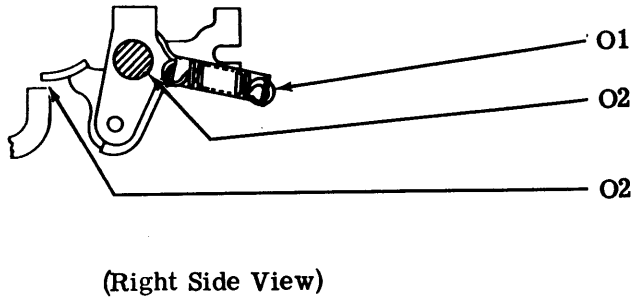

- | | | |
|----|------------------|--------------------|
| O1 | Hooks (Each End) | Spring |
| O2 | Bearing Surface | Bail Extension Arm |
| O2 | Contact Surface | Bail Extension Arm |

3.11 Print-Nonprint Solenoid Mechanism

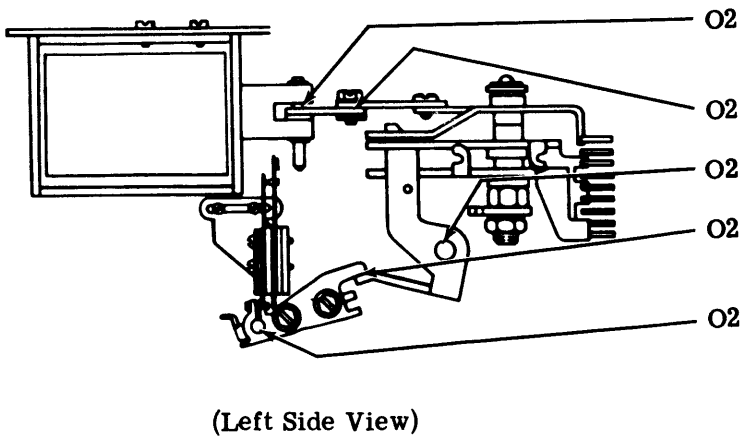

- | | | |
|----|------------------|-------------------------|
| O2 | Pivot Point | Solenoid Plunger |
| O2 | Pivot Point | Extension Link |
| O2 | Pivot Point | Blocking Bail |
| O2 | Blocking Surface | Blocking Bail Extension |
| O2 | Pivot Point | Trip Arm |

Note: Do not oil the cylindrical surface or pole face of solenoid plunger.

3.12 Vertical Tabulator and Transmitter Distributor Control Mechanism

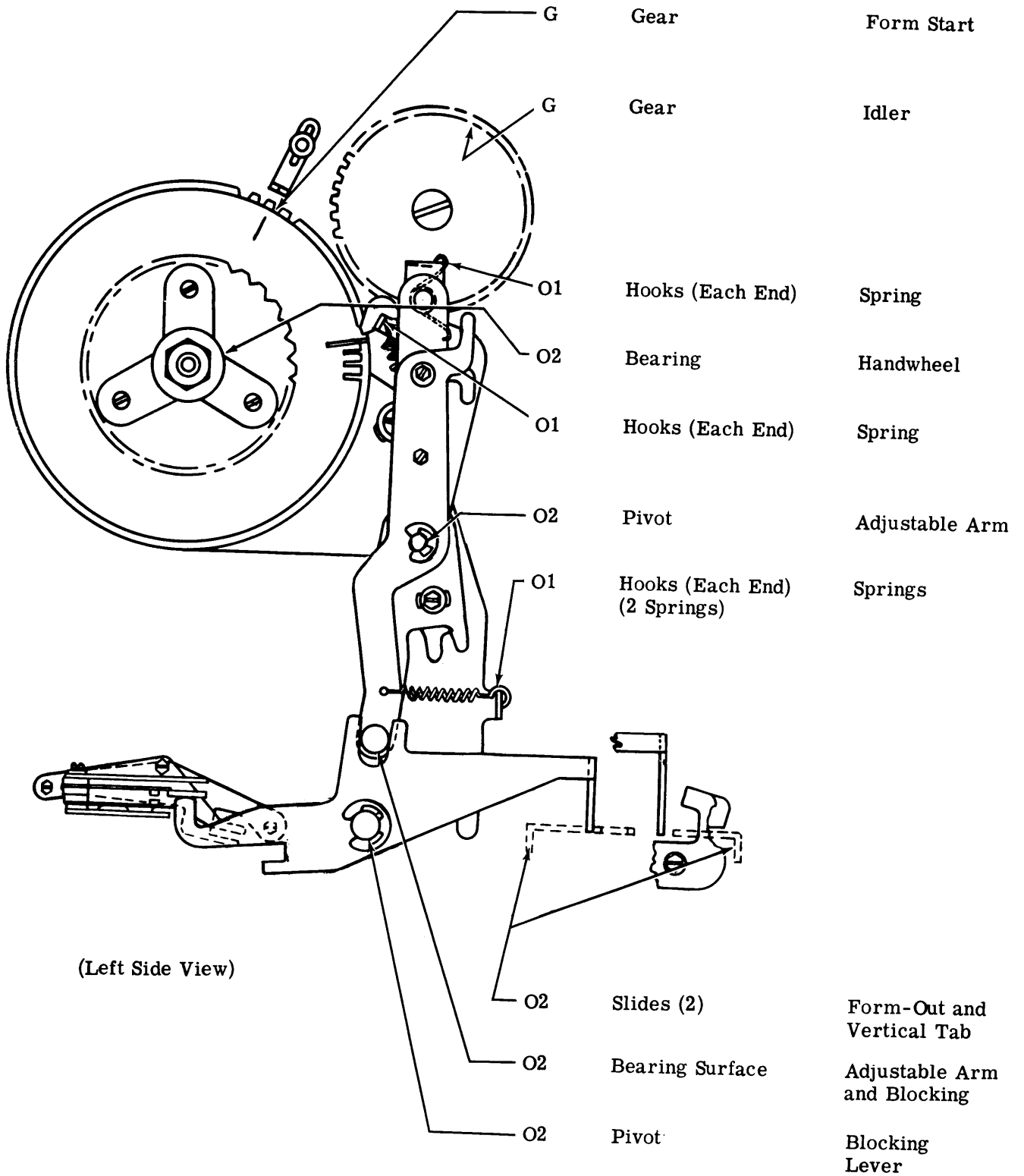

3.13 Form-Out Mechanism

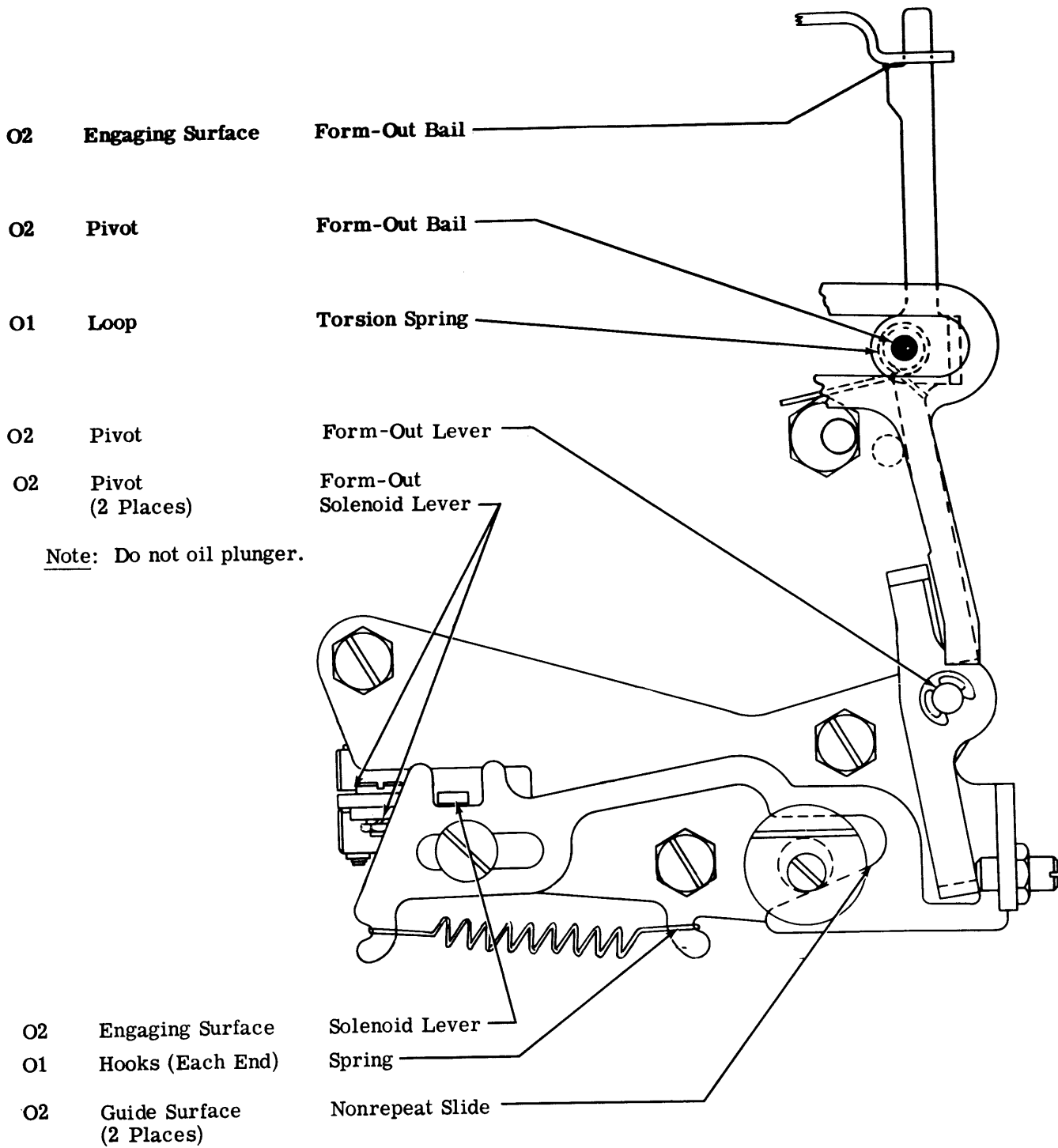

Note: Do not oil plunger.

(Left Frame Viewed From Right Rear)

3.14 Vertical Tabulator Mechanism (For Switch Network Service)

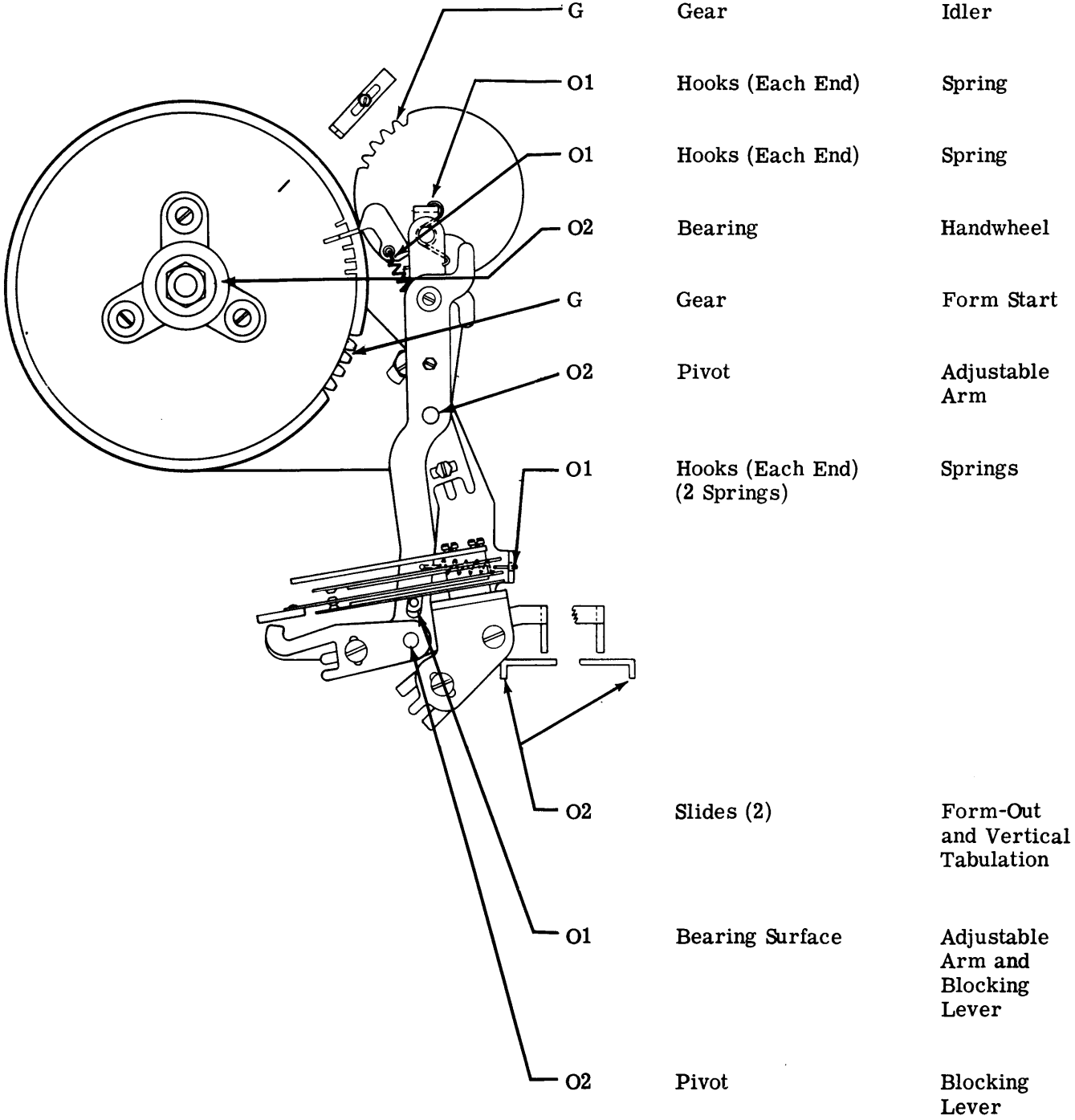

(Left Side View)

3.15 Two Color Ribbon Shift Mechanism — Oscillating Lever

Note: Photograph reference shows general area of this mechanism and not the actual mechanism.

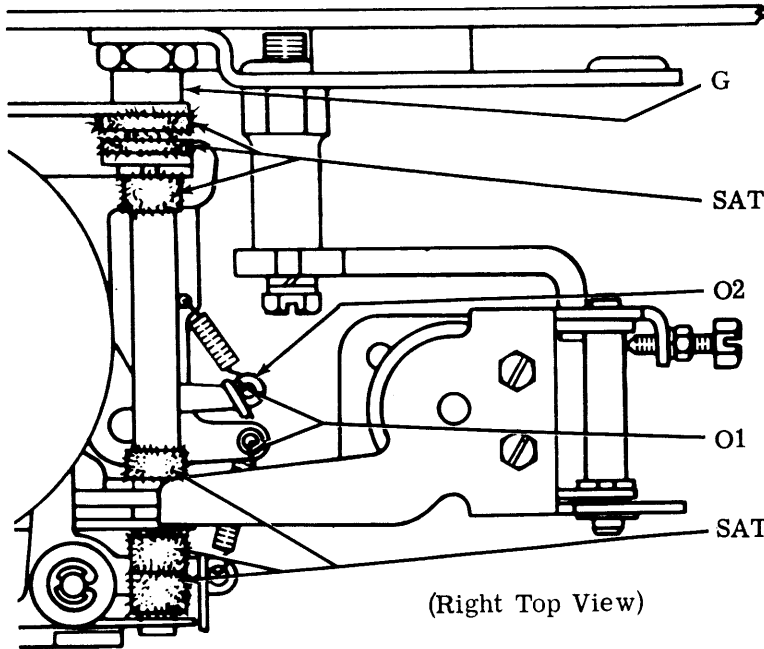

- | | | |
|-----|------------------------------|--|
| G | Shaft Mounting Surface | Oscillator Lever and Roller Bail Support Shaft |
| SAT | Felt Washers (3 Washers) | Ribbon Spool Bracket Shaft |
| O2 | Engaging Surface | Ribbon Reverse Lever |
| O1 | Hooks (Each End) (2 Springs) | Springs |
| SAT | Felt Washers (3 Washers) | Ribbon Spool Bracket Shaft |

(Right Top View)

3.16 Two Color Ribbon Shift Mechanism — Ribbon Operating Mechanism

Note: Photograph reference shows general area of this and not the actual mechanism.

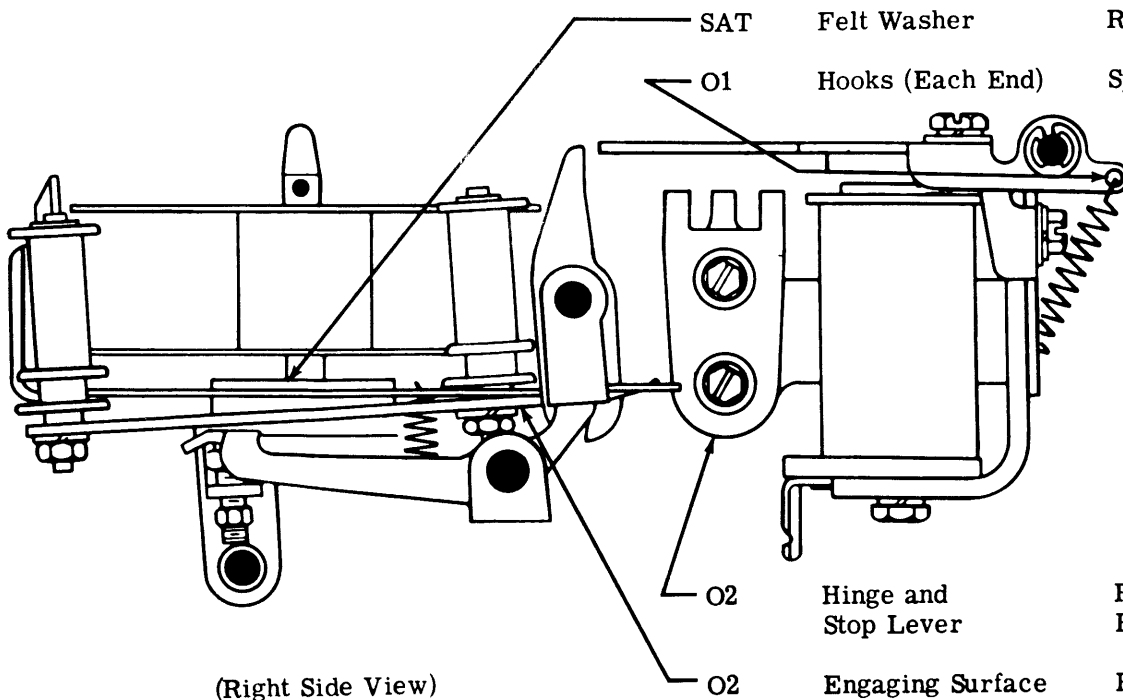

- | | | |
|-----|----------------------|-----------------------|
| SAT | Felt Washer | Ribbon Ratchet |
| O1 | Hooks (Each End) | Spring |
| O2 | Hinge and Stop Lever | Ribbon Magnet Bracket |
| O2 | Engaging Surface | Ribbon Spool Bracket |

(Right Side View)

3.17 Local Backspace Mechanism

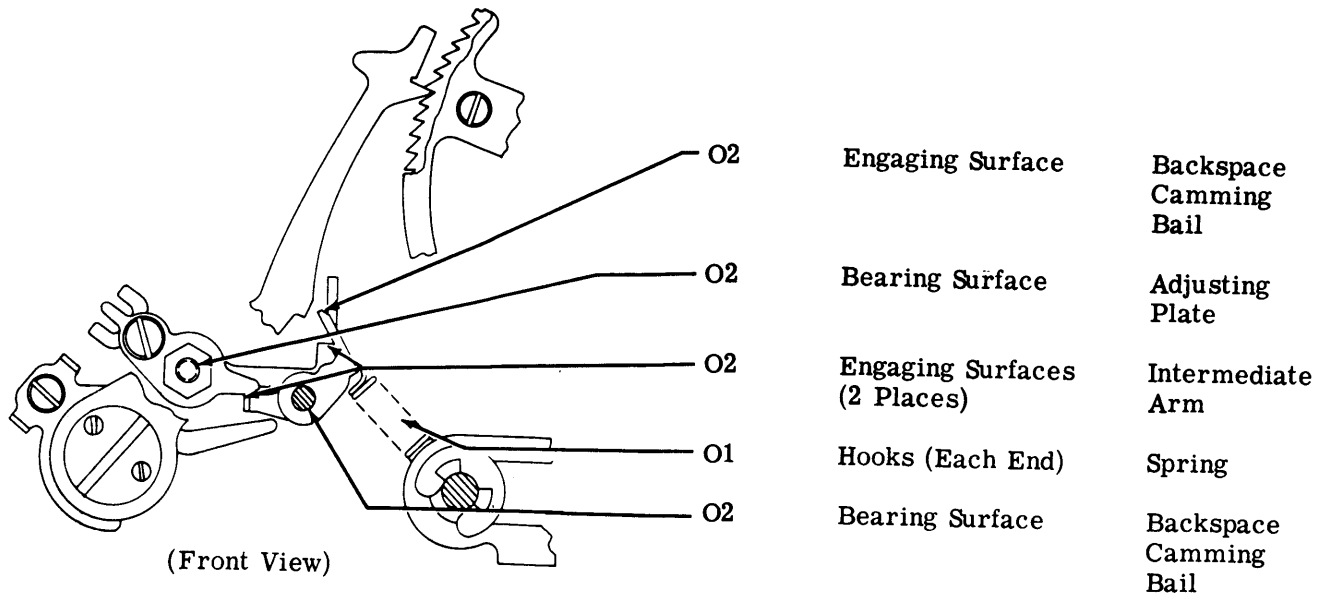

3.18 Paper-Out Alarm Mechanism (Friction Feed)

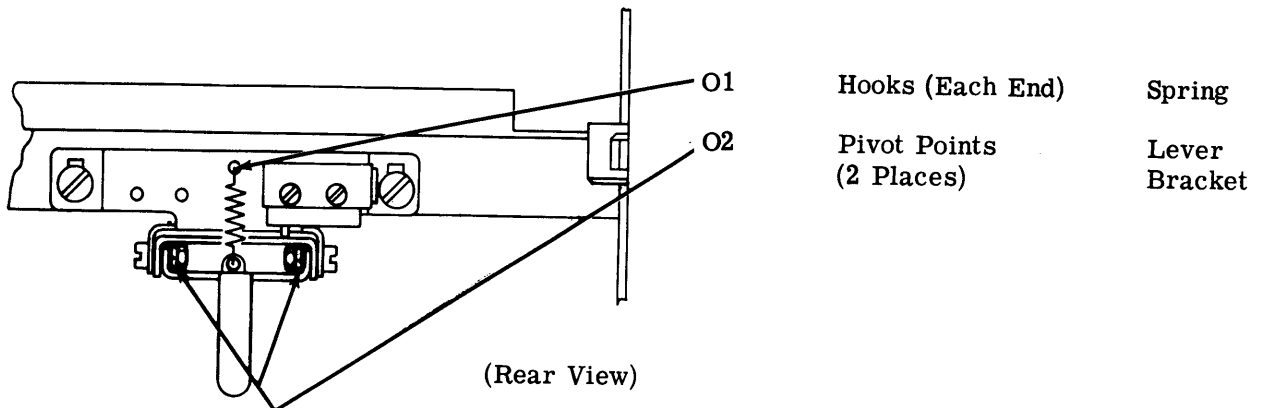
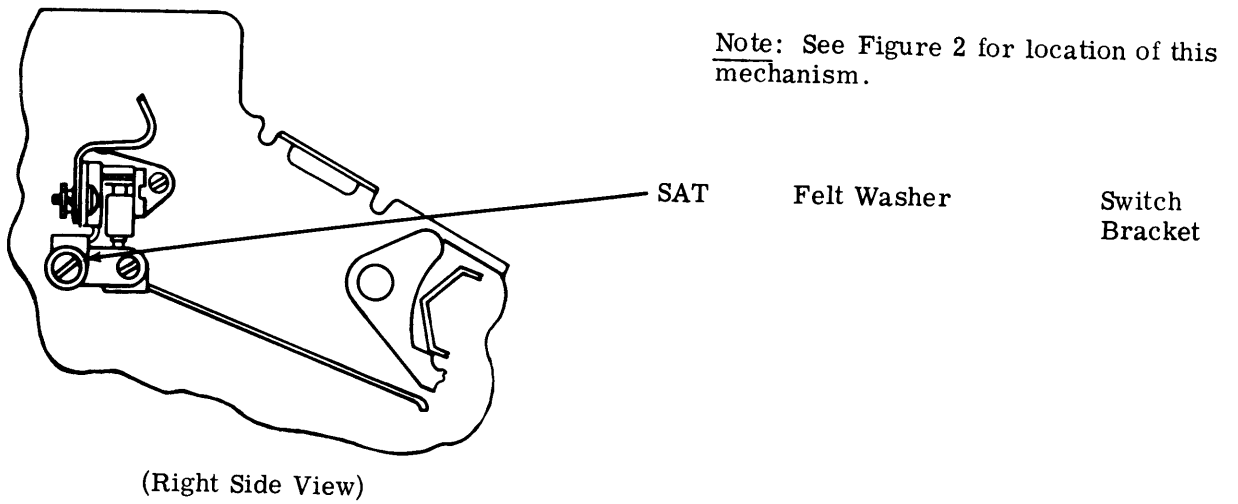

SECTION 574-220-701TC

3.19 Low Paper and Paper-Out Alarm Mechanism (Sprocket Feed)

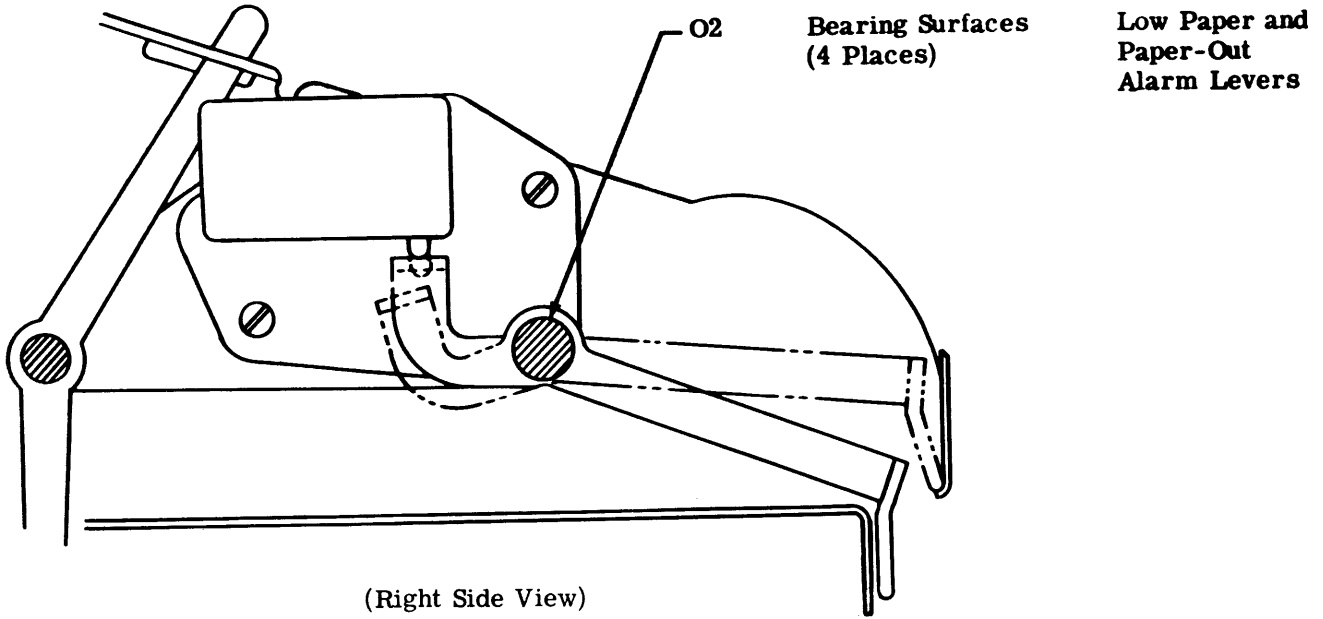

3.20 Keyboard Lock Mechanism

Note: Photograph reference shows general area of this mechanism and not the actual mechanism.

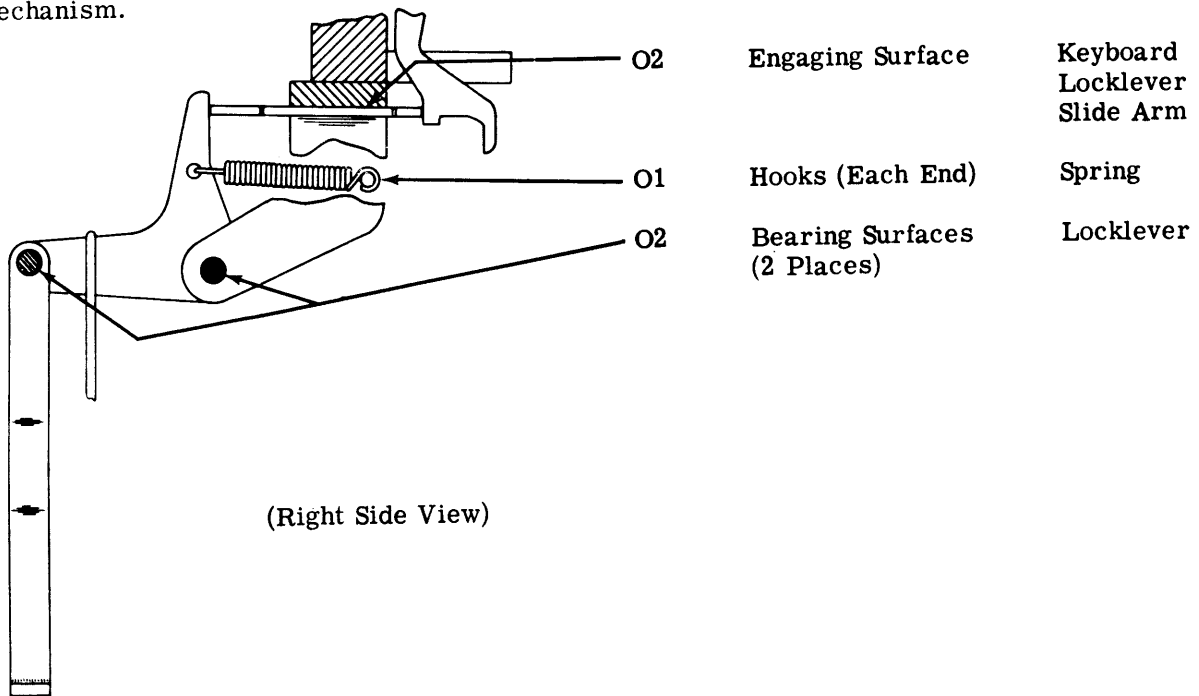

3.21 Paper Jam Alarm (Sprocket Feed)

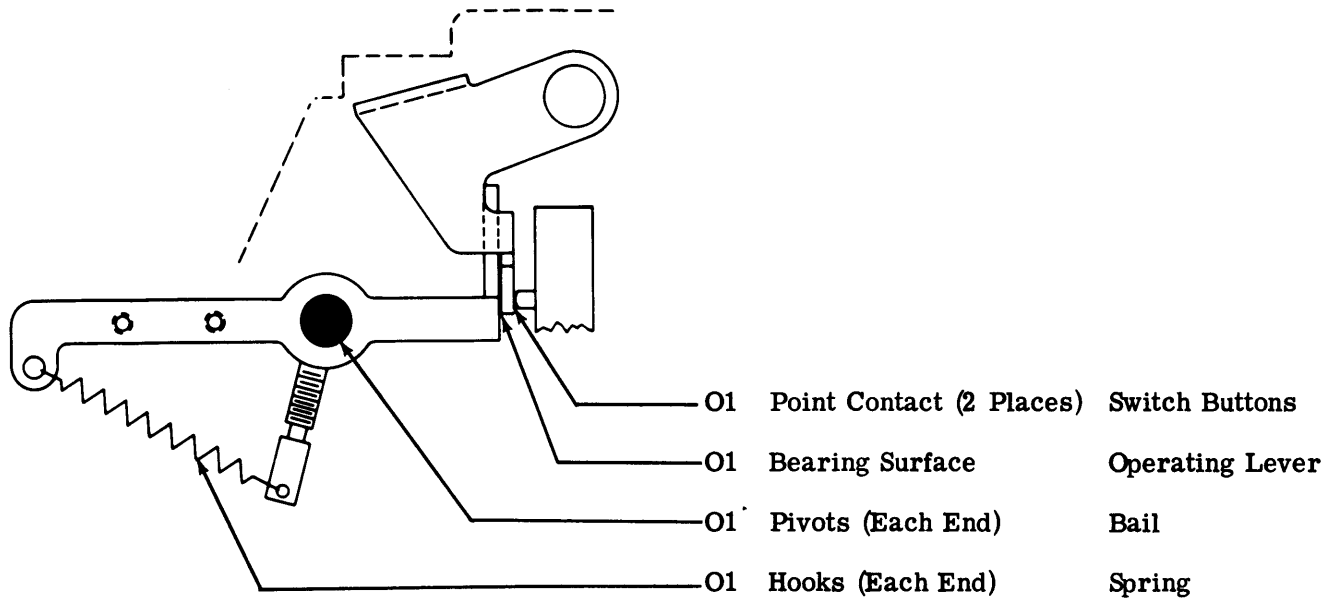

(Right Side View)

35 TYPING UNIT
 DISASSEMBLY AND REASSEMBLY

CONTENTS	PAGE
1. GENERAL	1
2. DISASSEMBLY AND REASSEMBLY . .	3
TYPE BOX	3
PRINTING CARRIAGE	3
TYPE BOX CARRIAGE	3
FRONT PLATE	3
STUNT BOX.	5
FUNCTION BAR	6
FUNCTION PAWL.	6
FUNCTION LEVER.	6
FUNCTION LEVER SPRING PLATE. .	6
CODE BARS.	6
MAIN SHAFT	7
UPPER DRAW WIRE ROPE	7
LOWER DRAW WIRE ROPE	7
PLATEN (FRICTION FEED)	8
PLATEN (SPROCKET FEED)	8
SELECTOR CAM-CLUTCH.	8
SELECTOR MECHANISM	9
CODE BAR POSITIONING MECHANISM	9
RANGE FINDER ASSEMBLY.	9
SELECTOR MAGNET ASSEMBLY . . .	9

1. GENERAL

1.01 Disassembly, as outlined in this section, covers a procedure for removing the principal sub-assemblies which make up the unit.

1.02 The technician should refer to the exploded views found in the appropriate parts literature for an illustration of the mechanism to be disassembled, for location and visual identification of parts and detailed disassembly and reassembly features.

1.03 Most maintenance, lubrication and adjustments can be accomplished simply by removing the subject component from the cabinet. If possible, disassembly should be confined to sub-assemblies, which can, in some cases, be removed without disturbing adjustments. When reassembling the sub-assemblies, be sure to check all associated adjustments, clearances and spring tensions.

1.04 If a part that is mounted on shims is removed, the number of shims used at each of its mounting screws should be noted so that the same shim pile-up can be replaced when the part is remounted.

1.05 Retaining rings (Tru-arcs) are made of spring steel and have a tendency to release suddenly when attempting to remove them. Loss of these retainers can be minimized as follows: Hold the retainer with the left hand to prevent it from rotating. Place the blade of a suitable screwdriver in one of the slots of the retainer. Rotate the screwdriver in a direction to increase the diameter of the retainer for removal.

1.06 Avoid loss of springs in disassembly by holding one spring loop with the left hand while gently removing the opposite loop with a spring hook. Do not stretch or distort springs in removing them.

1.07 Raise cabinet lid or enclosure cover (after removing the control panel bezel and the copylight plug) and remove the typing unit from its base by removing the four screws that secure it to its keyboard or base. Remove the cable plug connector from the side frame. Lift the typing unit off.

Note: On sets equipped with a form supply container on the rear of the cabinet, a rearward foot extension should be in

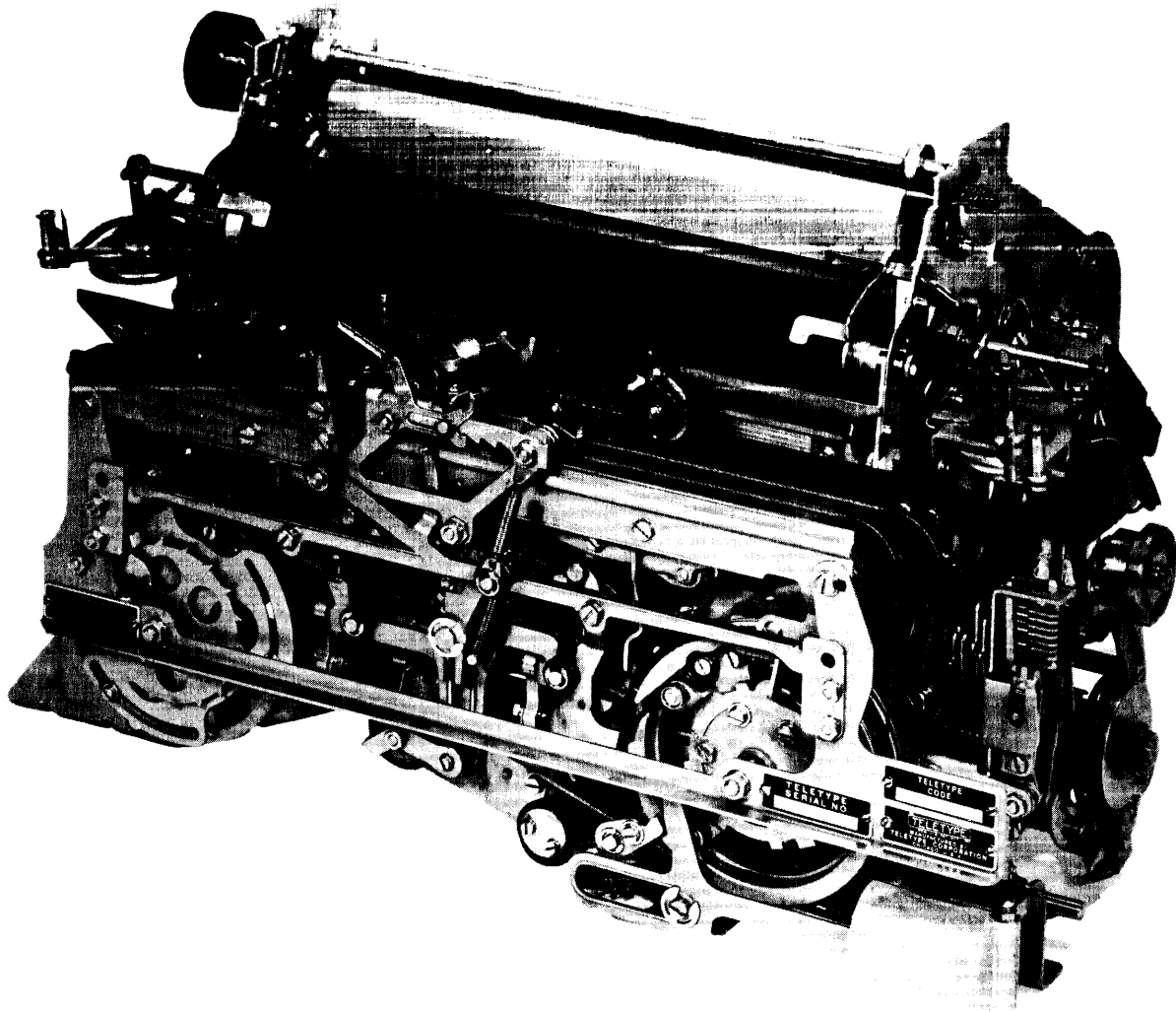

Figure 1 - 35 Typing Unit - Friction Feed

position on the cabinet. This prevents the cabinet from tilting when the typing unit is removed.

2. DISASSEMBLY AND REASSEMBLY

2.01 In removing a sub-assembly from the unit, the procedure followed and the location from which parts are removed must be carefully noted so that reassembly can be done correctly. Where no specific instructions are given for reassembly, reverse the procedure used in removing it.

TYPE BOX

2.02 To Remove: Trip the type box latch to the right. Lift the right end of the type box upward to an angle of approximately 45 degrees and pull toward the right to disengage it from the left hand bearing stud.

- (a) To disassemble the type box for replacing type pallet or spring, remove both screws and nuts that secure the front plate to the rear plate assembly. Separate the two plates.
- (b) Remove the spring from the pallet by compressing it slightly and pulling the formed end out of the slot in the pallet.
- (c) If the pallet is being replaced the spring should also be replaced. In any change or replacement, where the spring is removed, it should be replaced with a new one.
- (d) When installing the spring make certain that the formed end extends through the slot in the pallet.
- (e) To reassemble the type box, line up the front plate with the rear plate assembly and draw the two plates together until the head of the pallet leaves the rear plate by approximately 1/16 inch. This may be accomplished by using two 6-40 screws (at least 11/32" long) and nuts in place of the two screws and nuts removed when disassembling, and tighten them only enough to hold the pallets as specified above. Do not clamp the plates together until all pallets have been moved into their correct position.
- (f) Manipulate the pallets until they fall into their respective openings in the front plate. Press the plates together.

- (g) Replace the screws and nuts used in step (e) with screws and nuts removed in step (a).

2.03 To Replace Type Box: Reverse the procedure used in removing it.

CAUTION: TO AVOID SPRINGING THE TYPE BOX LATCH, THE TYPE BOX SHOULD BE FIRMLY SEATED ON THE BEARING STUD AND THE POINT OF THE LATCH SHOULD BE PLACED IN THE NOTCH OF THE TYPE BOX PLATE BEFORE MOVING THE LATCH TO ITS LOCKED POSITION.

PRINTING CARRIAGE

2.04 To Remove: Loosen the two screws in the printing-carriage clamp plate and disengage the carriage from the upper draw-wire rope. Move the carriage to the left of its track and tilt the lower part forward to disengage the rollers from the track.

2.05 To Replace: Make certain that the printing arm is correctly re-engaged with the printing track. Position the carriage clamp on the upper draw-wire rope for correct printing carriage position as specified in the adjustment section.

TYPE BOX CARRIAGE

2.06 To Remove: Move the type box carriage to its extreme right hand position.

- (a) Select a character which will shift the type box to its uppermost position.
- (b) Remove the ribbon from the ribbon guide.
- (c) Remove the retainer ring from the stud in the right hand end of the type box carriage link. Disengage the link from the carriage.
- (d) Hold the ribbon guide forward and the right ribbon reverse lever back. Pull the carriage toward the right to disengage it from the carriage track.

FRONT PLATE

2.07 To Remove: Manually move the type box carriage to the extreme right. Select any character in the bottom row of the type box and rotate main shaft until type box carriage is in its uppermost position.

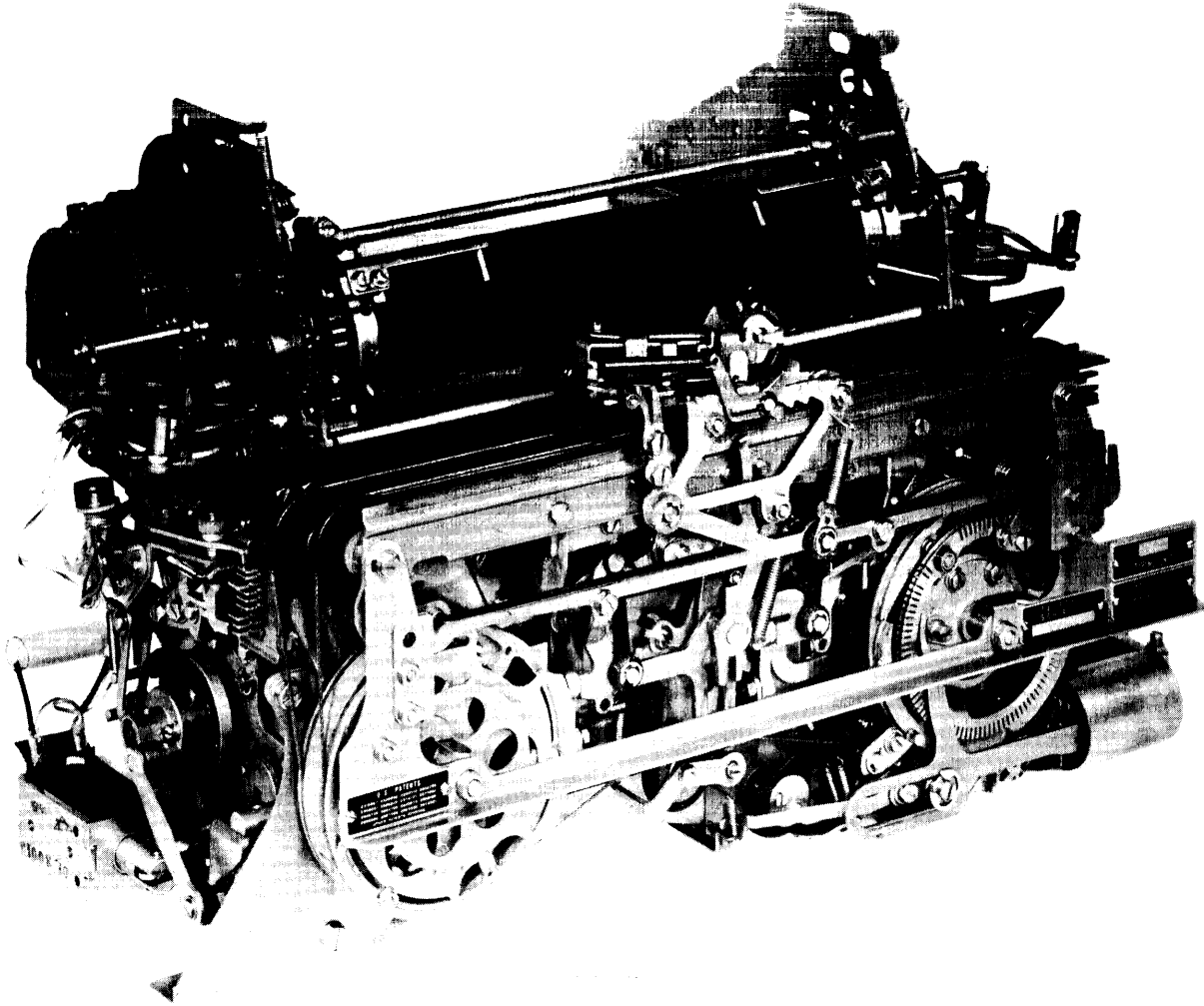

Figure 2 - 35 Typing Unit - Sprocket Feed

- (a) Remove the retainer ring from the type box carriage link right hand stud and disengage the link from the carriage. (See instructions for removing the link retainer in 2.06(c).)
- (b) Remove the three screws, which secure the main bail drive bracket to the rocker shaft.
- (c) Remove the spacing shaft gear.
- (d) Remove the four screws which secure the front plate assembly to the typing unit side frames.
- (e) Pull the front plate assembly forward to disengage it from its connecting parts in the typing unit.

2.08 To Replace Front Plate: Make certain that the TP150770 and TP150771 code bar bell cranks, the TP170063 reversing slide shift lever, TP157972 automatic CR - LF bell crank, if so equipped, and the TP152545 carriage return lever extension are properly engaged with their mating parts before tightening the front plate mounting screws.

2.09 Replace the spacing shaft gear. See appropriate section for adjustment on phasing the spacing gears.

STUNT BOX

2.10 To Remove: The procedure for removing the stunt box proper is essentially the same for both the friction feed units and sprocket feed units except that, preparatory to removing it from the sprocket feed unit, a number of other assemblies must first be removed, as follows:

- (a) Remove the two contact bracket assemblies and the magnet assembly from outside the left side frame.
 - (b) Remove the form-out switch assembly from the inside of the left side frame.
 - (c) Snap the form feed paper guide upward and slide it out.
 - (d) Unfasten the cable from the tie bar.
- 2.11 Remove the TP151627 rear tie bar from typing unit side frames.
- (a) Remove the line feed function pawl stripper from the TP160577 stripper blade.

- (b) Remove the screws which secure the stunt box assembly in the typing unit.
- (c) Remove the screw from the TP153291 cam shaft drive arm, and slide the drive arm to the left, out of engagement with the stripper blade drive arm.
- (d) Lift the stunt box assembly upward to disengage it from its locating brackets and pull toward the rear to disengage all code bar forks from the code bars. Remove the connector receptacle from the right side frame and disconnect the wires from selector magnets. Remove the stunt box.

Note: Proceed with 2.12 through 2.16 before replacing stunt box.

STUNT BOX SWITCH

2.12 To replace the contact arm spring in a stunt box switch, remove the two screws that hold the contact plate to the block.

- (a) Remove the contact plate assembly from the contact block.
- (b) Remove the contact arm(s) from the contact plate assembly by slipping contact arm spring out of engagement with the center lug of the section being replaced.
- (c) Place the new spring in position on the contact plate.
- (d) Before mounting the contact plate on the block make sure the end of the spring rests on top of the formed-over portion of the contact clip. There should be some clearance between the low end of the spring (front) and the upper edge of the contact arm to avoid interference with the normal movement of the contact arm.
- (e) Replace the contact plate assembly, with the contact arms removed, into the contact block. Mount the contact block in the required location with the two screws friction tight.
- (f) Insert the pointed end of the contact arm, notch downward, between the bent up end of the spring and the formed-over portion of the contact clip. Push the arm into its operating position in the contact block.
- (g) Before tightening the contact plate screws, see appropriate section on adjusting information.

SECTION 574-220-702

FUNCTION BAR

2.13 To remove a function bar, first unhook the function bar spring.

- (a) Hold the function bar toward the rear of the stunt box and disengage its function pawl from the function bar.
- (b) Pull the function bar toward the front to remove it from the stunt box.

FUNCTION PAWL

2.14 To remove a function pawl after the function bar has been removed:

- (a) Remove the pawl spring.
- (b) Hold associated function lever back.
- (c) Remove the pawl from top of stunt box.

FUNCTION LEVER

2.15 To remove a function lever after the function bar and function pawl have been removed:

- (a) Remove the TP152889 shaft retainer plate.
- (b) Remove the TP150547 shaft nearest the front of the stunt box.
- (c) Unhook spring from function lever and remove the lever through top of stunt box.

FUNCTION LEVER SPRING PLATE

2.16 To remove a function lever spring plate or latch after the function bar, function pawl and function lever have been removed:

- (a) Loosen the screws that fasten the three TP150689 guide blocks to the lower side of the guide bar.
- (b) Remove the spring from the TP152660 spring plate or TP154613 latch.
- (c) Pull downward on the function-lever spring plate or latch to snap it out of engagement with the retainer shaft.

2.17 To replace the stunt box, push it forward in its guide rails to within 1/8 inch of its final position.

2.18 Manually disengage the function pawls from their function bars and push the stunt box assembly forward and downward until it is latched in place on its locating brackets.

2.19 Replace the stunt box mounting screws, receptacle and selector magnet wires. (If unit is sprocket feed, replace other assemblies removed.)

CODE BARS

2.20 To unblock the suppression code bar, loosen the TP151152 screw that mounts the TP154650 code bar clip and the retaining plate to the left hand code bar guide bracket and rotate the code bar clip up out of engagement with the suppression code bar. Tighten the screws.

2.21 To Remove the Code Bar Assembly: First, remove the stunt box assembly and the front plate assembly as previously described.

- (a) Remove the screws and lock washers which secure the code bar assembly to the side frame.
- (b) Remove the TP150301 code bar shift bar retainer plate from right-hand code bar guide bracket.
- (c) Unblock the suppression code bar as instructed in 2.20. Remove the TP152548 and TP152255 code bar shift bars and springs from the code bars and pull the code bar assembly forward and to the left.

2.22 To Reinstall Code Bar Assembly: Reverse the procedure used in removing it, except do not tighten the mounting screws.

- (a) Hook the short extension of the TP152257 spring in the spring hole of the code bar. The short extension of the spring should be hooked from the bottom of the code bar and the long extension should be hooked over the top of the code bar shift bar.
- (b) Loosen the TP151630 code bar assembly tie bar screws and hold the code bar guide brackets back and downward firmly against their locating surfaces on the side frame and tighten the four mounting screws.
- (c) Tighten the two tie bar screws.

MAIN SHAFT

- 2.23 To Remove Main Shaft. The selector cam-clutch assembly must be removed.
- (a) Set the typing unit upside down.
 - (b) Return the carriage to its left hand position.
 - (c) Remove the screw that secures the spacing shaft in the spacing collar.
 - (d) Remove the spacing shaft with gear.
 - (e) Remove the screw that secures the collar and the clamp to right end of main shaft.
 - (f) Remove the TP152573 main shaft right hand bearing retainer plate.
 - (g) Remove the TP150010 retainer plate at the TP150046 clutch bearing and remove the TP150244 link.
 - (h) Remove the two screws from the TP152537 main shaft left hand bearing clamp.
 - (i) Unhook the springs from the trip levers and latch levers associated with all clutches. Position the code bar clutch so that the low part of the clutch cam clears the spring arm on the cam follower. Unhook the code bar clutch cam follower spring.
 - (j) Remove the TP153300 function clutch arm by removing the two screws and retainer ring if present.
 - (k) Unhook the spring from the TP153573 function bar.
 - (l) Move the main shaft assembly toward the left to disengage the code bar clutch and function clutch links from their connecting pins.
 - (m) Lift the left end of the shaft assembly out of the side frame. Position the shaft so that the function clutch link passes the suppression assembly bracket, then remove the shaft assembly from the typing unit.

Note: Disassembly of the main shaft and the clutch assemblies can be accomplished by referring to the exploded views contained in the appropriate parts literature.

It should be noted, that when assembling clutches that have cams and disks marked "O" for identification, the marked side of the parts should face away from the clutch side of the assembly. Function and code bar clutches should have their driving links assembled so that the longer end of the hub faces away from the clutch side of the assembly.

- 2.24 To Reinstall Shaft Assembly: Reverse the procedure used in removing it. The line feed clutch spur gear should be positioned with its flat side toward the line feed clutch spacer and with the indentation in the gear toward the special washer between the gear and the main shaft ball bearing.

- 2.25 To phase the spacing gears, and remake the stripper blade drive cam position adjustment refer to the appropriate adjustment section.

UPPER DRAW WIRE ROPE

- 2.26 To Remove Upper Draw Wire Rope: Return the carriage to the left hand position.
- (a) Loosen the nut on the front end of the spring drum stud. Operate the ratchet escapement lever to unwind the carriage return spring.
 - (b) Remove the upper draw wire rope from the clamp plate on the printing carriage, and the clamp on the oscillating rail slide.
 - (c) Loosen the clamp screw that secures the upper draw wire rope to the spring drum. Remove the wire rope from the drum.
 - (d) Remove the screw in the spacing drum that secures the ends of the wire rope. Remove the rope from the drum.

LOWER DRAW WIRE ROPE

- 2.27 To Remove Lower Draw Wire Rope: Remove the screw that secures the wire rope to the spacing drum. Remove the end of the rope from the drum.
- (a) After loosening the screws that secure the TP150796 margin indicator cam disk on the spring drum, position the disk to expose the lower draw wire rope mounting screw.
 - (b) Remove the lower draw wire rope screw and rope from the spring drum.

SECTION 574-220-702

(c) Loosen the screws in the pulley bearing studs that mount draw wire rope pulleys and move the studs toward the center of the typing unit.

2.28 To Replace Draw Wire Rope: Make certain that the lower draw wire rope is in front of the upper draw wire rope in the track around the drums.

2.29 Adjust the position of the type box, the printing carriage, and the wire rope tension as specified in the appropriate adjusting section.

PLATEN (FRICTION FEED)

2.30 To Remove Platen: Remove the line feed spur gear.

- (a) Remove the TP150719 and TP150720 platen bearing retainers.
- (b) Remove the TP152832 paper straightener shaft.
- (c) Hold off the detent and lift the platen out of the side frame.

2.31 When replacing each platen bearing retainer, put its upper screw in first. Leave the screw slightly loose. Press the lower end of the retainer downward and hook it into the elongated hole in the side frame. Replace the lower screw. Tighten both screws.

PLATEN (SPROCKET FEED)

2.32 To Remove Platen: Remove the paper fingers or guide bracket assembly.

- (a) Remove the spur gear from left end.
- (b) Remove the TP150719 and TP150720 platen bearing retainers.
- (c) Hold off the detent bail and remove the platen.
- (d) Remove sprocket hub assembly from platen assembly.
- (e) Insert the TP153673 shaft tool into the hub and fasten it with the TP151346 screw.
- (f) Remove the TP157286 clamp and TP153699 cam from the assembly.

(g) Insert the hub into the TP153797 retaining tool.

Note: These tools must be used when disassembling the TP153700 platen hub in order to hold the spring loaded pins in place when the feed cam is replaced.

2.33 To Replace a Pin: Rotate the hub assembly within the retaining tool, with a tommy wrench inserted in the shaft tool, until the desired pin is opposite the notch in the retaining tool. A pin may then be removed or replaced. Grease pin cylinder liberally before inserting new pin.

CAUTION: WHILE ROTATING THE HUB, THE NOTCH MUST BE COVERED TO PREVENT THE PINS FROM BEING RELEASED. SINCE THE PINS ARE SPRING LOADED, THEY CAN EJECT WITH CONSIDERABLE FORCE.

2.34 To Replace Platen: Reverse the procedure used in removing it. In replacing the TP153686 right sleeve bearing, the chamfer side or side marked "O" must face the end of the shaft and the wide part placed toward the front of the unit. When replacing each platen bearing retainer, put its upper screw in first. Leave the screw slightly loose. Press the lower end of the retainer downward and hook it into the elongated hole in the side frame. Replace the lower screw. Tighten both screws.

SELECTOR CAM-CLUTCH

2.35 To Remove Selector Cam-Clutch: Lift and move to rear the TP170238 push lever reset bail cam follower from its cam and latch it in its raised position on the push lever guide. Lift the selector levers and the marking lock lever by moving the marking lock lever forward until the armature drops behind it.

- (a) Remove the screw which mounts the selector clutch drum and position the cam clutch so that the stop lug on the clutch-cam disk is in the uppermost position.
- (b) Place TP170238 pushlever-reset bail in raised position. Hold TP170198 stop arm and TP170236 marking lock lever to left, grasp cam-clutch by cam-disk (not by drum) and pull forward while rotating cam-clutch slowly. Cam-clutch should come off easily. Do not force it.

2.36 To Replace Cam-Clutch Assembly: Reverse the procedure used in removing it except as the cam-clutch approaches its fully installed position, move the trip shaft lever and the cam-clutch latch lever so that they ride on their respective cams. Restore the push lever reset bail and the armature to their operating position.

SELECTOR MECHANISM

2.37 To Remove Selector Mechanism: The cam-clutch assembly must first be removed. See 2.35.

- (a) Remove the TP151658 screw that secures the selector mechanism to the TP170118 intermediate bracket on the code bar positioning mechanism.
- (b) Remove from the selector mechanism the spring which connects with the common transfer lever on the code bar positioning mechanism.
- (c) Remove the remaining three selector mounting screws and lift the selector from the main shaft bearing housing.

CODE BAR POSITIONING MECHANISM

2.38 To Remove Code Bar Positioning Mechanism: Unhook from the selector the spring attached to the common transfer lever and restore any operating push levers to the spacing position by raising the TP170238 push-lever-reset bail.

- (a) Loosen the clamp screw on the TP150447 shift lever drive arm, and remove the two screws which mount the mechanism -

one to the side frame and one to the selector mounting plate.

- (b) Manipulate the transfer levers and TP152548 or TP152255 code bar shift bars while gently twisting the mechanism so as to slide the mechanism off the code bar shift bars.

2.39 To Remove Code Bar Positioning Mechanism on the typing unit: Rotate the main shaft in the stop position, push the code bar shift bars to the marking position (left front view). Manipulate the code bar shift bars and transfer levers so that the shift bars line up with their respective slots in the TP170117 bracket, and slide the shift bars through the slots, one at a time, leaving the bottom slot vacant.

RANGE FINDER ASSEMBLY

2.40 To Remove the Range Finder Assembly: Remove the two screws and the nut that mount it to the selector-mounting plate. Move the TP152438 stop arm bail forward so that it disengages from the TP170237 start lever and clears the selector clutch disk, while rocking the range finder assembly back and forth as it is removed.

SELECTOR MAGNET ASSEMBLY

2.41 To Remove Selector Magnet Assembly: Remove the two screws and nut which mount the range finder to the selector.

- (a) Remove the selector-magnet cable from the coil terminal screws.
- (b) Remove the two magnet assembly mounting screws and lift the assembly out.

35 KEYBOARD AND BASE FOR KEYBOARD SEND-RECEIVE (KSR) AND RECEIVE-ONLY (RO)
 TELETYPEWRITER SETS

DESCRIPTION AND OPERATION

CONTENTS	PAGE	1. GENERAL
1. GENERAL.	1	1.01 This section is reissued to include the latest engineering changes concerning gold-plated contacts. Arrows in the margins indicate changes or additions.
KEYBOARD.	1	
RECEIVE-ONLY BASE	1	
SIGNAL GENERATOR.	3	
2. PRINCIPLES OF OPERATION	3	KEYBOARD
GENERAL.	3	1.02 The 35 Keyboard (Figures 1, 2 and 3) supports the motor unit and the typing unit, and incorporates code selecting and signal generating mechanisms. Signal line and power line circuits are also included. The keys are positioned in a four row arrangement with most punctuation marks, and special symbols and functions, available in upper case positions. The keyboard, with typing unit and motor unit mounted in position, is placed within the cabinet. The front of the keyboard protrudes beyond the cabinet and is fitted with a rubber pad that seals the edges of the aperture for a silencing effect. Motive force for activating the keyboard is derived from the motor by way of the typing unit. The keyboard may or may not be equipped with an answer-back.
KEYBOARD.	3	
INTERMEDIATE SHAFT ASSEMBLY.	3	
CODEBAR MECHANISM AND SIGNAL GENERATOR.	3	
LOCAL CARRIAGE RETURN MECHANISM.	9	
LOCAL LINE FEED MECHANISM.	9	
REPEAT MECHANISM	10	
MARGIN INDICATOR MECHANISM	10	
CONTROL KEY MECHANISM.	10	
SHIFT KEY MECHANISM.	12	RECEIVE-ONLY BASE
3. RECEIVE-ONLY BASE	12	1.03 The 35 Receive-Only Base is used in place of the keyboard when receiving facilities only are required. It supports the motor unit and the typing unit, and provides for local carriage return and local line feed operation of the typing unit. It does not incorporate code selecting and signal generating mechanisms. The base may or may not be equipped with an answer-back.
4. VARIABLE FEATURES.	13	
EVEN PARITY.	13	
A. General	13	
B. Shift With Even Parity.	13	
C. Control Key With Even Parity.	13	
5. TECHNICAL DATA.	14	1.04 The wall mounted Receive-Only Base has the same features as the table and floor model (Figure 4) except for the intermediate shaft assembly and the motor location (2.03 and 2.06).
A. Signal.	14	
B. Operating Speeds	14	
C. Electrical Requirements	14	

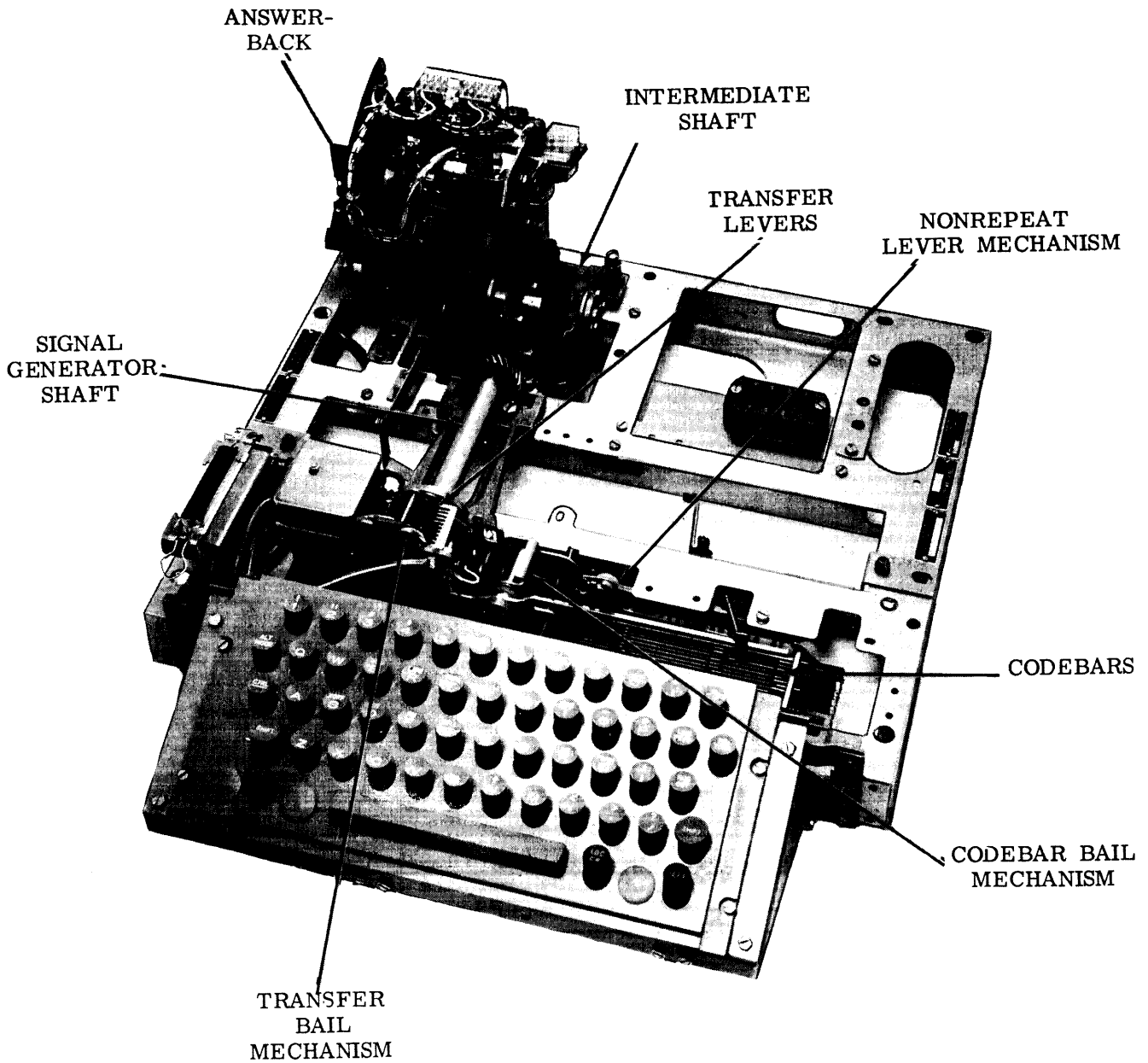

Figure 1 - 35 Keyboard for Send-Receive Sets (Front View)

SIGNAL GENERATOR

1.05 The signal generator consists of a frame assembly; front and rear plate assemblies; gear, shaft, clutch and cam assembly; and a contact box assembly (Figure 9).

1.06 The clutch stop and latchlevers are mounted on the frame.

1.07 The codebar assembly and nonrepeat lever with its guide are mounted on the rear.

1.08 The front plate acts as a mount for the detent plate assembly; transfer bail and stud; transfer levers with their guides, springs, and mounting studs; and the locking bail with its stud and spring.

1.09 The cam, clutch, and shaft assembly is mounted between the front and rear plates. The cam is one piece of machined steel with ten lobes. The eight lobes which generate pulse signals, are equal in contour and are positioned at uniform angles with one another. The number four cam differs in contour, and is used to actuate the transfer lever locking bail.

1.10 The universal bail latchlever with its eccentric bushing is fastened to the right front of the frame. This latchlever extends to the rear over the codebar bail latch and the nonrepeat lever pawl.

1.11 The contact box assembly is mounted on the front plate. It is composed of a fiber insulating strip, a contact toggle assembly, phenolic base, and drive link.

1.12 The signal contacts may be made of either tungsten or gold-plated tungsten.

Note: Gold-plated contacts may be used for both standard applications (including those with data sets) and special low-level applications. However, once used for standard application, they may not be suitable for special low-level application.

2. PRINCIPLES OF OPERATION**GENERAL**

2.01 These paragraphs cover the operating principles and descriptions of the 35 Keyboard and Base for Keyboard Send-Receive and Receive-Only Sets.

KEYBOARD

2.02 The Keyboard embodies a sheet metal structure on which an intermediate shaft assembly, a codebar mechanism with keylevers, and a signal generator mechanism are mounted. It also contains a margin indicator switch mechanism, and provides mounting facilities for a typing unit and a motor unit. All electrical wiring is brought into the keyboard through a receptacle mounted at the left side of the keyboard base. A main cable interconnects the various electrical components with this receptacle. (Answer-back has separate plug.)

Note: The main power switch, margin indicator lamp, signal bell and copy illuminating lamps are mounted on the keyboard on wall mounted models.

INTERMEDIATE SHAFT ASSEMBLY

2.03 The intermediate shaft assembly located in the rear central portion of the keyboard, supports the helical gear assembly. The helical gear assembly transfers the motive force to the typing unit main shaft, and (if present) answer-back assembly. On table and floor models, the motor unit is mounted on top of the base, and the intermediate shaft assembly contains two helical gears. The motor engages the intermediate shaft assembly by means of the motor pinion and intermediate shaft driving gear. On wall mounted models the intermediate shaft assembly contains one helical gear and one pulley. The motor unit mounts below the base, and its pinion engages with and drives a belt. The belt in turn engages with and drives the pulley and the attached intermediate shaft assembly.

CODEBAR MECHANISM AND SIGNAL GENERATOR. (See Figures 5, 8, and 9.)

2.04 As a code selecting keytop is depressed, the corresponding codelever rotates about its pivot point. The rear end of the codelever comes up and rotates the universal bail. The extension arm on the top of the universal bail moves out of engagement with the step at the rear end of the universal bail latch. This occurs when the key and corresponding codelever are about two-thirds of the way toward full stroke. The universal bail latch then moves downward under spring force developed by the universal bail latch spring. As this latch comes down, it strikes the codebar reset bail latchlever and carries it downward. When the corner

of the reset bail latch descends beyond the center line of the needle bearing (mounted on the reset bail), the various spring forces acting on the reset bail cause it to swing to the right. This in turn allows the various codebars to move to the right (in the direction of the spring forces acting on each codebar). While this is happening, the codelever is moved up to its full position. Therefore, the codelever may stop some of the codebars from moving to their extreme right hand position. The codebars have vertical extensions that engage a curved part of the signal generator transfer levers. Those codebars that are permitted to move to the extreme right also move the corresponding transfer lever to the right. However, those codebars that are stopped, because their teeth en-

gage the actuated codelever, do not quite touch or move their corresponding transfer levers. Hence, these transfer levers remain in their normal left hand position (Figure 9).

2.05 Simultaneously with the trip-off of the reset bail and the movement of the codebars to the right, the clutch tripbar (located in the rear slots of the codebar guides) moves to the right. This clutch tripbar engages the clutch stop lever and moves it out of latch with the clutch stop lug. Up to this point, all of the action has been caused by manual operation of the keytop and its associated codelever (Figure 5).

2.06 The motor unit supplies the mechanical power to drive the associated typing unit

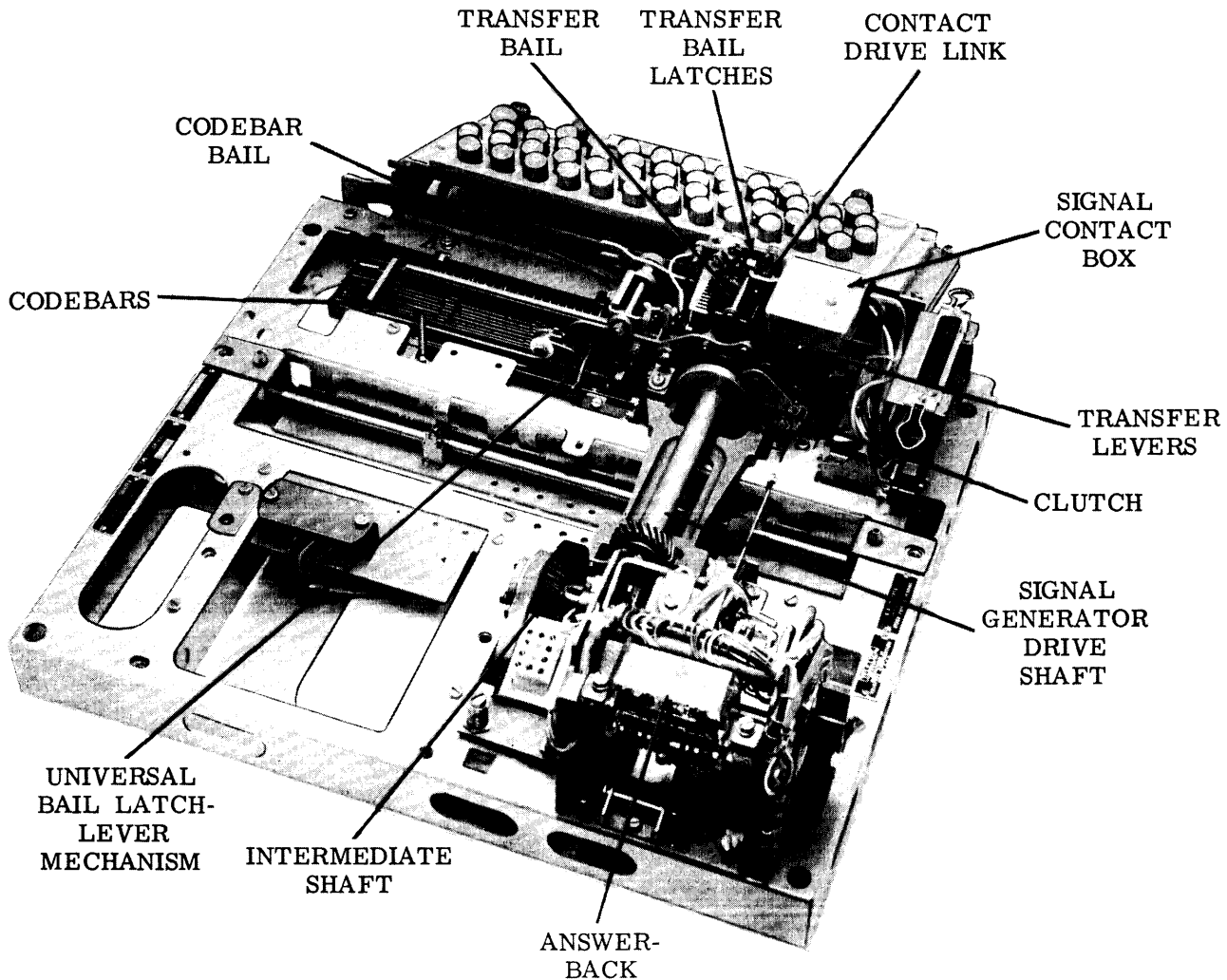

Figure 2 - 35 Keyboard for Send-Receive Sets (Rear View)

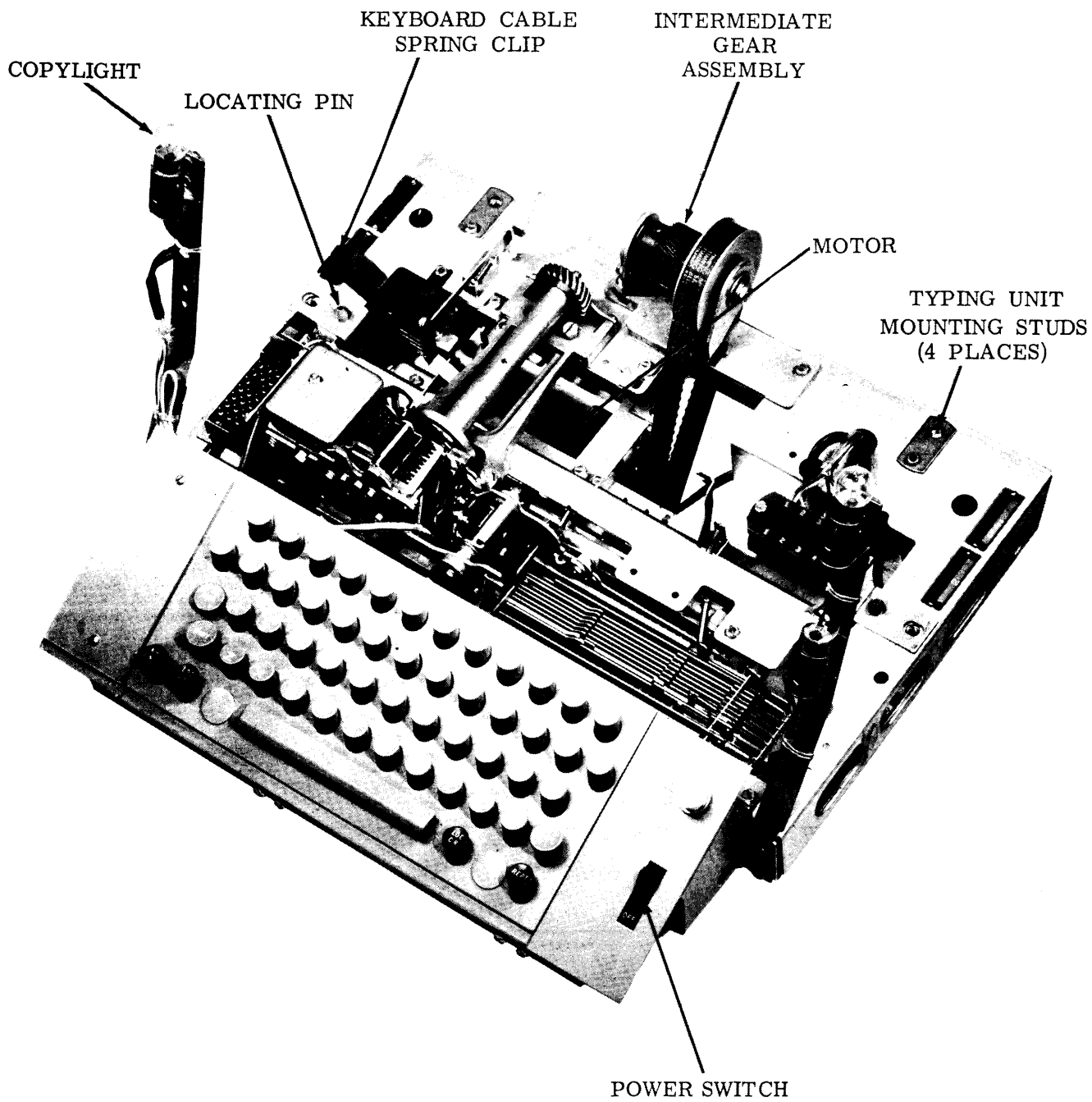

Figure 3 - 35 Keyboard for Wall Mounted Send-Receive Sets

SECTION 574-221-100

and the signal generator shaft that is geared to the typing unit main shaft. The motor unit is mounted on top of the keyboard base, on the right rear corner on table and floor models, and below the keyboard base, on the left rear side, on wall mounted models.

2.07 Once the clutch is tripped, it rotates continuously as long as the keyboard is turned on. Since the clutch shoes are mounted on a plate that is part of the cam assembly, the cam begins to rotate (clockwise when viewed from the front of the keyboard).

2.08 The arrangement of the cam assembly is such that the fourth cam from the rear begins to push downward on its corresponding transfer lever. At almost the same time, the first cam from the front begins to move the transfer lever locking bail upward. The blade portion of this locking bail goes up beside a downward projection on each transfer lever. The "locking" projection is left or right of the locking bail, depending upon the position of the transfer lever (as set up by the permutation action of the codebars). Thus, in the first few degrees of cam rotation, the permuted position of the transfer levers is located into posi-

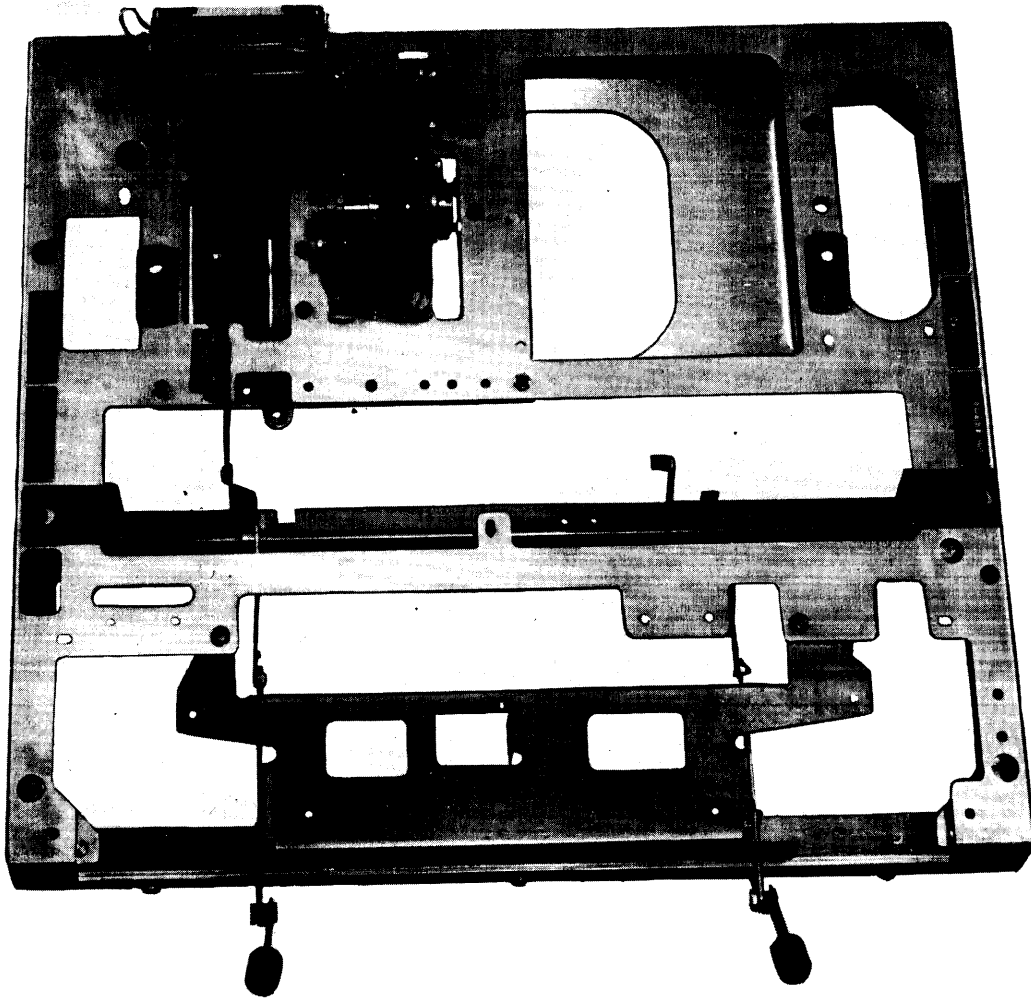

Figure 4 - 35 Receive-Only Base for Table and Floor Model Sets

tion and the codebars are free to be reset in their normal latched position.

2.09 The cams and their corresponding transfer levers are numbered from rear to front. The number 4 cam engages its transfer lever first; and moves it down. Since the start pulse is always spacing, no codebar is required to engage this lever. Hence it is always held to the left by its spring. Therefore, as the fourth cam moves the lever down, the hook at the upper right side of the transfer lever engages the right side of the transfer (rocker) bail. This tips the transfer bail to the right and pulls the contact drive link to the right. The resulting action of the contact toggle is such that the left set of contacts acts as a pivot and the right hand con-

tacts begin to open. The right hand contacts are the ones that control the signal current in single contact type operation. When these contacts are open, the result is no current in the signal circuit. Therefore, the first pulse, the start pulse of any character code is a spacing (no current) pulse.

2.10 The number 1 cam and the transfer lever move downward next. In turn, the upper left hook of the associated transfer lever pulls down on the rocker bail (holding it to the right or tilting it back to the left). This pushes the drive link to the left (or right) resulting in closing the right (or left) contacts and allowing a marking (or spacing) pulse to be transmitted.

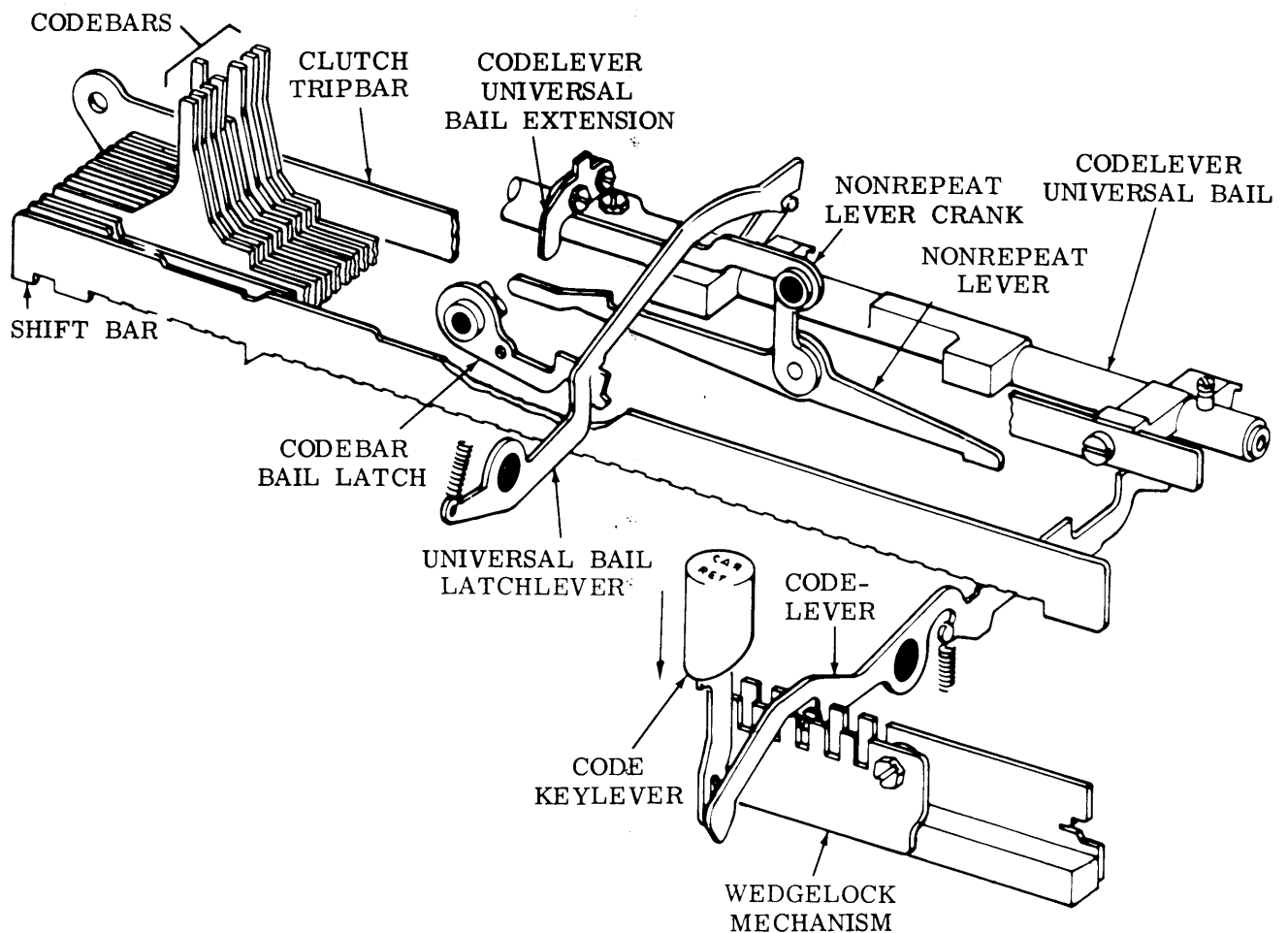

Figure 5 - Codebar and Codelever Universal Bail Mechanism

2.11 Similarly, the remaining transfer levers are pulled downward by their respective cams. The resulting pulse is marking if the transfer lever is to the right or spacing if it is to the left. The last transfer lever is held to the right by a stop pin. Therefore, the last pulse (the stop pulse) is always marking (current on).

2.12 The locking bail is actuated by a cam lobe. This cam begins to move the locking bail up into its locking position almost as soon as the cam starts to rotate (Figure 9). Full lock position occurs approximately at the half-way point of the start pulse (48-1/2 degrees of rotation). The dwell on the first cam from the front holds the lock bail in its lock position until after the beginning of the last pulse. Then the cam pulls

the bail down out of lock, and all transfer levers are free to return to their initial positions at a point about half-way through the stop pulse.

2.13 Reset of the codebars is accomplished by means of an eccentric on the front of the cam assembly, which drives an eccentric follower arm (Figure 7). This arm engages a stud on the side of the codebar reset bail and pulls the reset bail to the left as the cam rotates. At the peak position of the reset eccentric, the codebar reset bail latch is clear of the needle bearing stud. This permits the latch spring to pull the latch up into locking position and the codebar reset bail is latched as the eccentric drives the follower arm back to its initial position. As the codebar reset bail is moved to the left (into

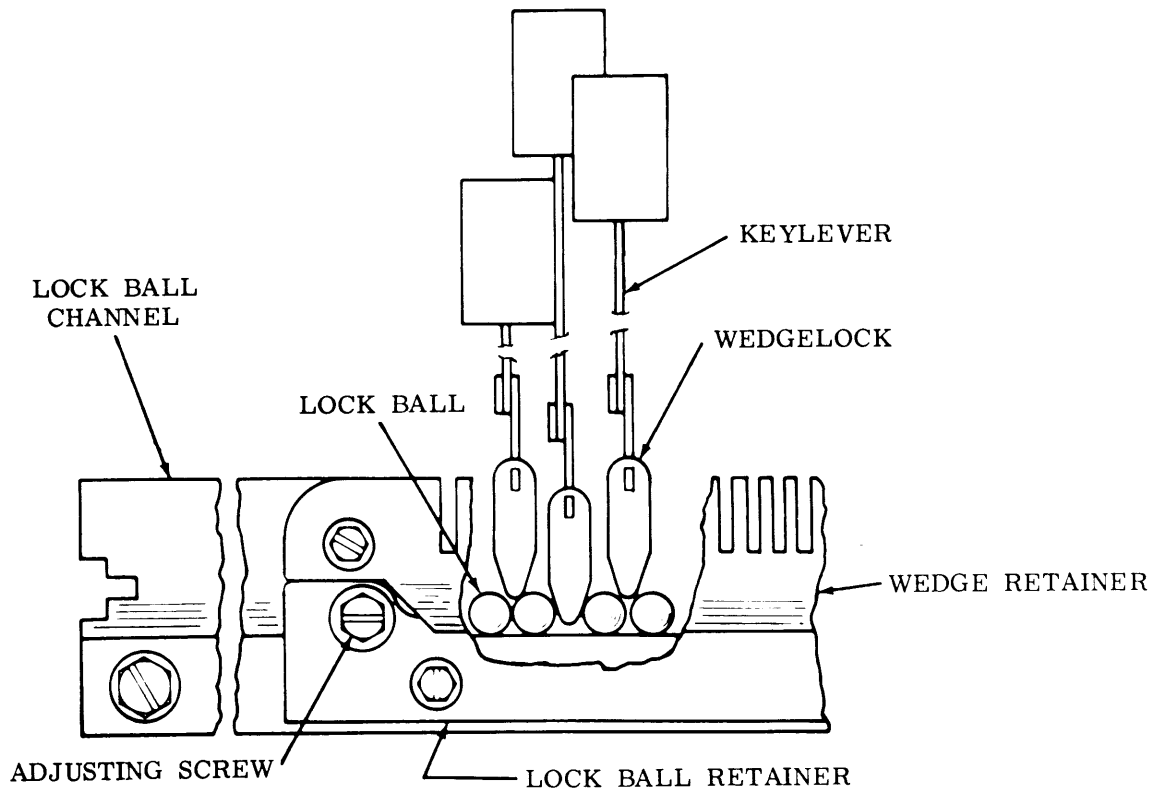

Figure 6 - Wedgeloek Mechanism

reset), it engages projections on the permutation codebars, clutch tripbar, and a step on the non-repeat lever. Thus, all of these elements are moved to the left into latched reset position.

2.14 The reset eccentric is so positioned in angular relationship to the remainder of the cam that pick-up of the codebars and non-repeat lever begins at $92\frac{1}{2}$ degrees. At 145 degrees, the codebars have been moved to the left a sufficient distance to permit the code lever (that determined the permutation) to drop down out of the universal bail. This permits the universal bail to rotate forward and kick the nonrepeat lever down and off the reset bail. At the same time, the extension of the universal bail moves in under its latchlever and holds this latchlever up almost in the same position that the pawl on the nonrepeat lever had held it in the early reset movement. With the universal bail latch held up, the reset bail continues to move to the left. Full rest occurs at approximately 180 degrees of cam rotation. As soon as the universal bail is permitted to move forward, a second keytop can be depressed. However, from that point on, full time of cam rota-

tion must expire before a third and successive keytops can be operated.

LOCAL CARRIAGE RETURN MECHANISM

2.15 Operation of the local carriage return keylever causes its function lever to raise the forward end of the local carriage return bail (Figure 10). The bail rotates about its pivot point until the upper end engages the carriage return lever on the typing unit. Thus, the carriage return mechanism on the local typing unit is made to operate without disturbing the other typing units on the same line circuit.

LOCAL LINE FEED MECHANISM

2.16 Operation of the local line feed keylever causes its function lever to raise the forward end of the local line feed bail (Figure 12). The bail rotates about its pivot point and the upper end pushes the trip link until the link engages the line feed clutch trip lever on the typing unit. Thus, the line feed mechanism on the local typing unit is made to operate without disturbing the other typing units on the same line circuit.

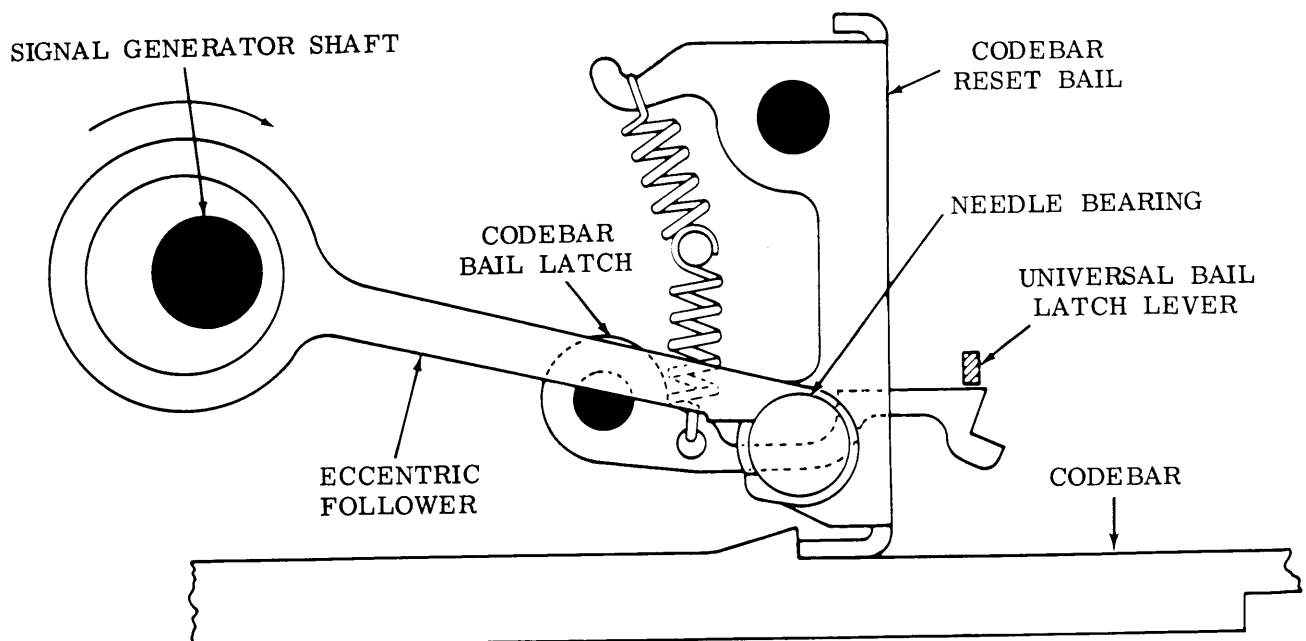

Figure 7 - Codebar Bail Mechanism

REPEAT MECHANISM

2.17 Operation of the repeat keylever simultaneously with one of the keylevers or the spacebar disables the nonrepeat mechanism and causes the character or function selected to be repeated as long as the repeat keylever is held operated. The operated repeat keylever causes its function lever to raise the right end of the nonrepeat lever (Figure 13), and rotate it about its pivot point. In this position, the non-repeat keylever cannot be engaged and operated by the codebar bail. Therefore, the nonrepeat bell crank will not reset the operated codelever bail latchlever which then maintains both the codelever bail and the codebar bail latchlever in their operated positions until the repeat keylever is released.

MARGIN INDICATOR MECHANISM

2.18 The margin indicator cam disc on the typing unit spring drum rotates with the

drum as printing or spacing occurs. As the end of each line is approached, the cam surface of the disc makes contact with the margin indicator contact lever and rotates it clockwise about its pivot point (Figure 14). When the contact lever leaves the switch plunger, the margin indicator switch operates and closes the circuit to a margin indicator light. A carriage return cycle returns the cam disc to its starting position and the margin indicator switch opens.

CONTROL KEY MECHANISM

2.19 Depression of the control key introduces the upper case of a specific key by the deletion of the number 7 pulse. This is accomplished by the control codelever blocking the number 7 codebar from falling to the right.

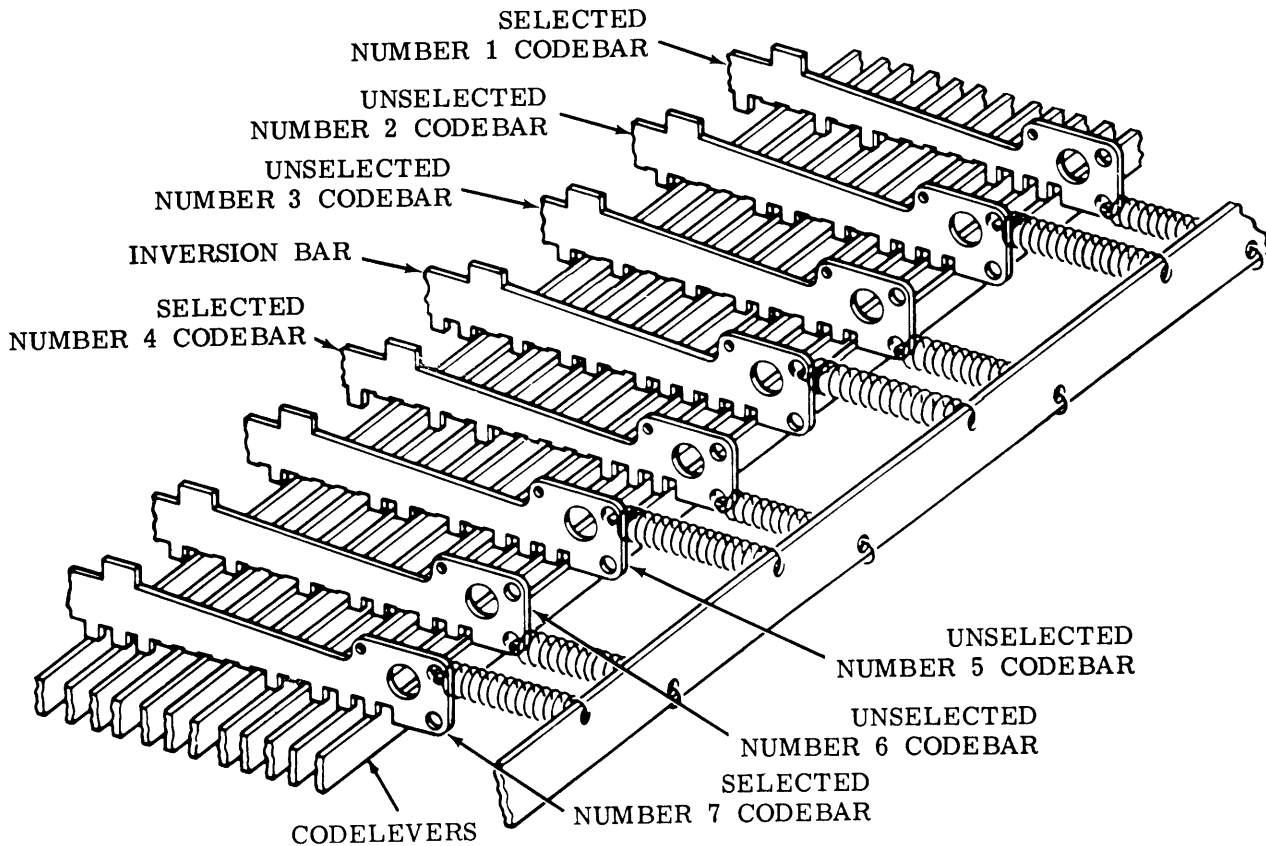

Figure 8 - Codebar Selection

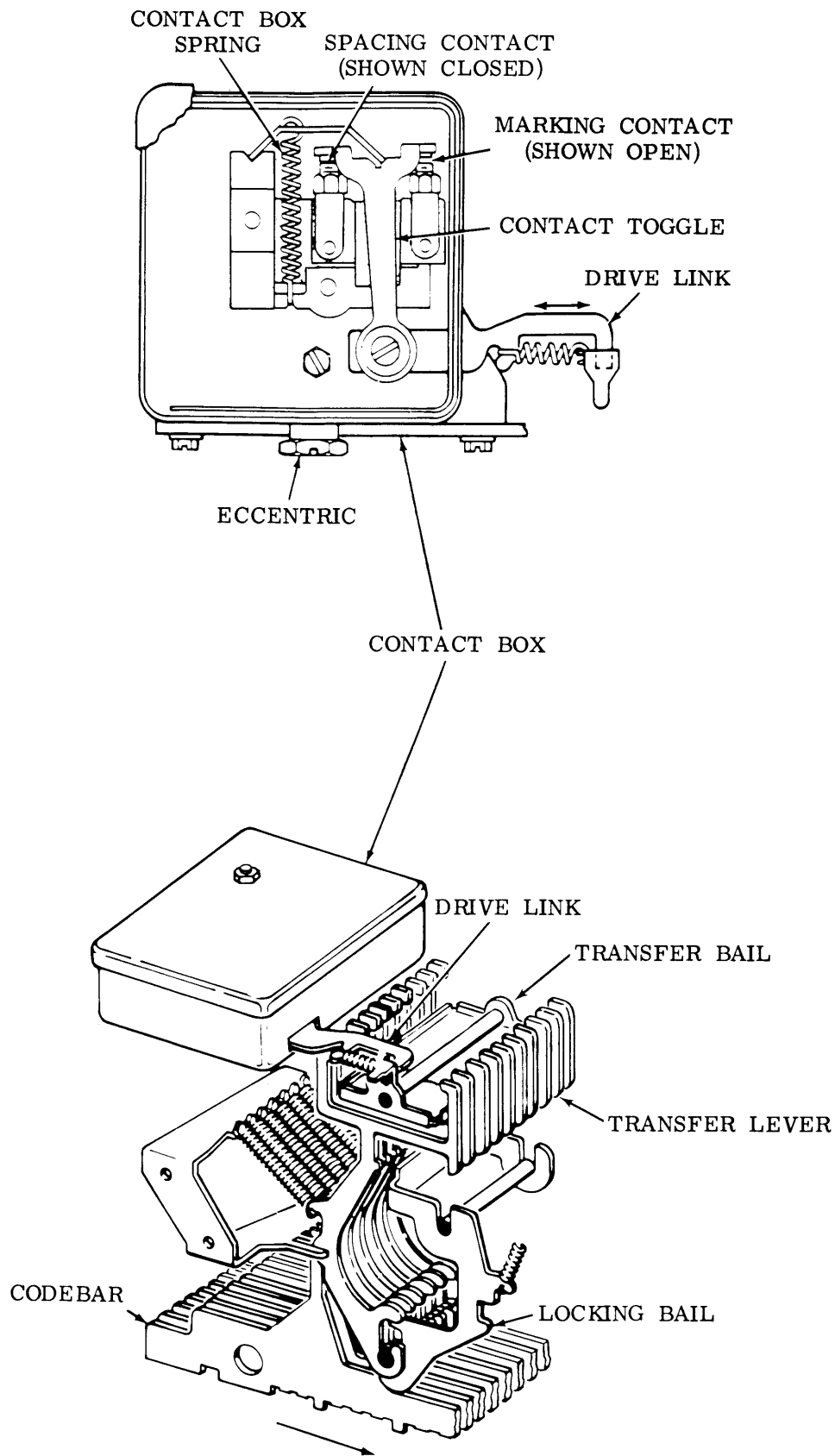

Figure 9 - Transfer Lever Mechanism and Contact Box Mechanism

SHIFT KEY MECHANISM

2.20 To obtain a shift bit inversion case character, the enlarged shift key (at either side of the keyboard) is held down while depressing a complimentary key. This shift key preconditions the keyboard for the function of adding or deleting (as the case may be) the number 5 code bit to obtain its complimentary key code. This is accomplished by means of a shift codelever engaging a diagonal camming surface, on the under side of the shift lockbar (outside slot of the codebar guide), and directing its motion to the left. As this motion develops, the bail riding the upper diagonal camming surface

is raised. This permits the inversion codebar (feed hole slot) to fall only when the complimentary key is depressed. This inversion bar, upon falling to the right, operates a transfer lever number 5 pulse by a mechanical connection. The code transmitted is then the addition or omission of the number 5 pulse combined with the transfer levers selected by the complimentary key.

3. RECEIVE ONLY BASE

3.01 The Receive-Only Base is a sheet metal structure which supports an intermediate shaft assembly (Paragraph 2.03) and provides

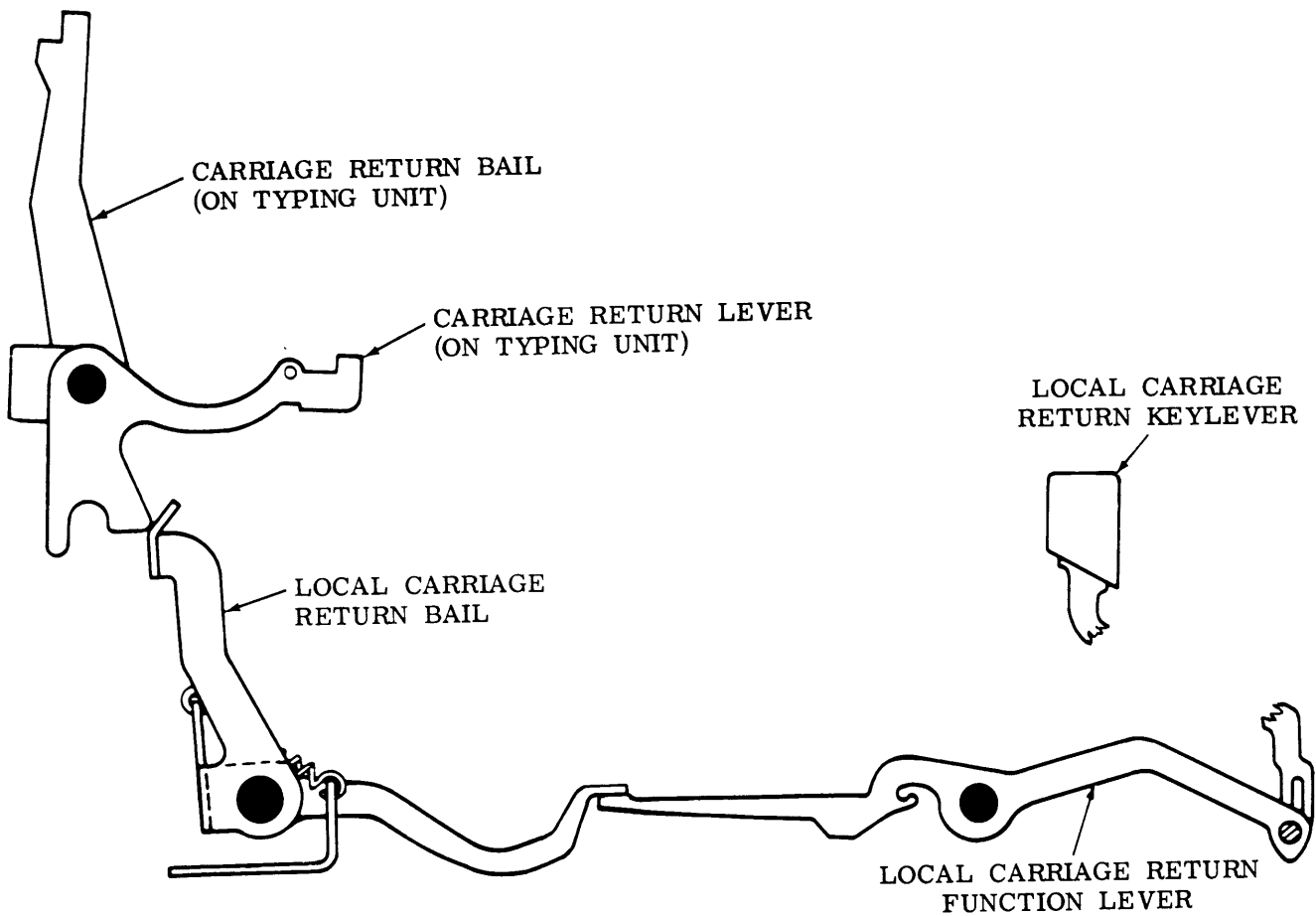

Figure 10 - Local Carriage Return Mechanism

mounting facilities for a typing unit and a motor unit. On the front of the base two offline function keylevers, local carriage return and local line feed (Paragraphs 2.15 and 2.16), are mounted. All electrical wiring is brought into the base through a receptacle mounted at the left rear of the base. A main cable interconnects the various electrical components with this receptacle. The base may or may not be equipped with an answer-back.

4. VARIABLE FEATURES

EVEN PARITY (See Figure 11)

A. General

4.01 In keyboards equipped to provide an even parity output, the eight bit of the signal code may be either marking or spacing, in order to always supply an even number of marking pulses for each code combination transmitted.

B. Shift With Even Parity

4.02 Depression of the shift key and its related mechanism inverts the number 5 and number 8 marking bits to spacing or spacing bits to marking as the case may be. This is a means of obtaining an upper case or symbol associated with a particular keytop and is accomplished by holding down the enlarged SHIFT key (at either side of the keyboard) while depressing a complimentary key. The shift codelever prevents the no. 5 codebar from falling and at the same time conditions the keyboard for the function of inverting the space-to-mark bit or the mark-to-space bit as required to obtain its complimentary key code with parity. This is accomplished by means of a shift codelever engaging a diagonal camming surface on the underside of the shift lockbar directing its motion to the left. The shift lockbar serves a dual purpose; it blocks out the selected group of keys and inhibits the complimentary keys from being actuated prematurely. As the motion to the left develops, the upper bail riding the upper diagonal camming surface on the shift lockbar, is raised. This raises the blocking tine and permits the no. 5 inversion codebar, if coded marking, to fall. At the same time a pivoted follower attached to the shift lockbar, rides up a "V" shaped camming surface on the control lockbar. This raises the blocking surface of the lower blocking bail allowing the no. 8 inversion codebar to fall, if coded marking, and blocks the no. 8 codebar. Upon falling to the right, the codebars unlatch their respective

transfer levers causing the proper permutation to be generated.

C. Control Key With Even Parity

4.03 Depression of the CTRL (control) key will cause the seventh bit to space and the eighth bit to invert. This is a means of obtaining a control function with an even parity bit. It is accomplished by holding the control key down while depressing a complimentary key. The control key operates a control lockbar, which serves the purpose of both blocking out those keys to which a control is not associated and preventing a complimentary key from being actuated prematurely, by means of its saw tooth design. The control key codelever engages a diagonal camming surface on the underside of the control lockbar directing its motion to the left, as it blocks the no. 7 codebar from falling to the right (mark position). As motion develops, the follower engages the "V" shaped camming surface of the control lockbar, and moves up, raising the lower blocking bail. The lower bail, in its upward travel, unblocks the no. 8 inversion codebar and permits it to fall to the right (if coded marking). As the codebars fall to the right they operate their respective transfer levers causing the proper permutation to be generated.

4.04 The design of the keyboard allows the depression of the shift and control keys simultaneously. Holding the shift and control key down while depressing the proper complimentary key will generate S3 through S7 and NULL. As the shift and control keys are depressed their key codelevers engage a diagonal camming surface on the underside of their respective lockbars directing them to move to the left. As the shift lockbar moves, its upper diagonal camming surface causes the upper blocking bail to rise, unblocking the no. 5 inversion codebar so that it may fall to the right if marking. The shift key codelever blocks the no. 5 codebar. As the control lockbar moves, the follower attached to the shift lockbar rides in the "V" shaped camming surface on the control lockbar. Since the total travel of the two lockbars is the same the follower will not ride up on either of the camming surfaces and the lower blocking bail remains in its normal position. This causes the no. 8 inversion codebar to remain blocked and allows the no. 8 codebar to fall to the right when marking. The codebars, upon falling to the right, permit the proper combination of marking bit 1 through 8 to be generated.

5. TECHNICAL DATA

A. Signal

Code Sequential, 11-unit
eight-level, start-stop

Operating Limits:

Voltage 3 to 260 v dc
Current 0 to 60 milliamperes

B. Operating Speeds

Standard Speed. . . 60, 75 or 100 words per
minute with standard
speed change gears

Intermediate Speed . . . Available by using
special speed
change gears

Special Speed Available by using a
governor controlled
motor in place of the
synchronous type
normally used

C. Electrical Requirements

5.01 Electrical contacts for certain optional
features, such as the answer-back mech-
anism, and signal regenerator circuit generally
require 110 v ac circuitry, however the specific
nature of these circuits depend on the external
controls operated by the contacts.

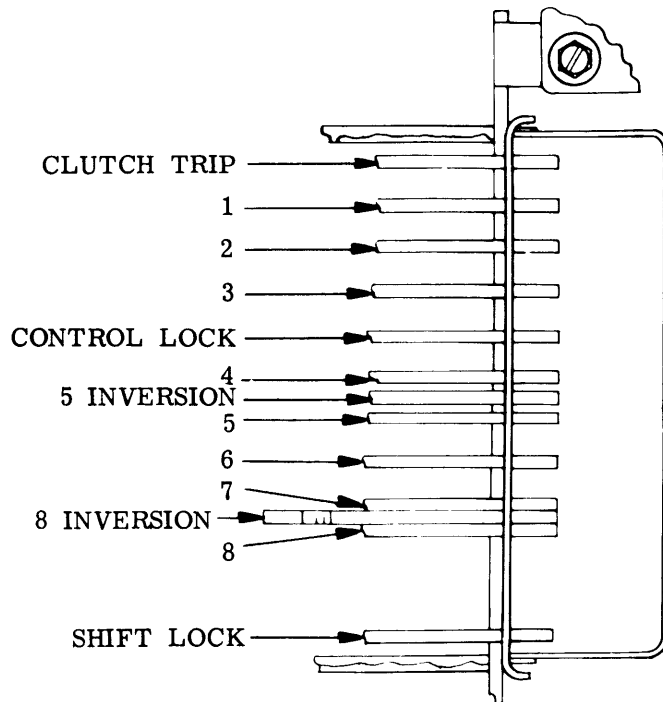

Figure 11 - Codebar Arrangement With Even Parity

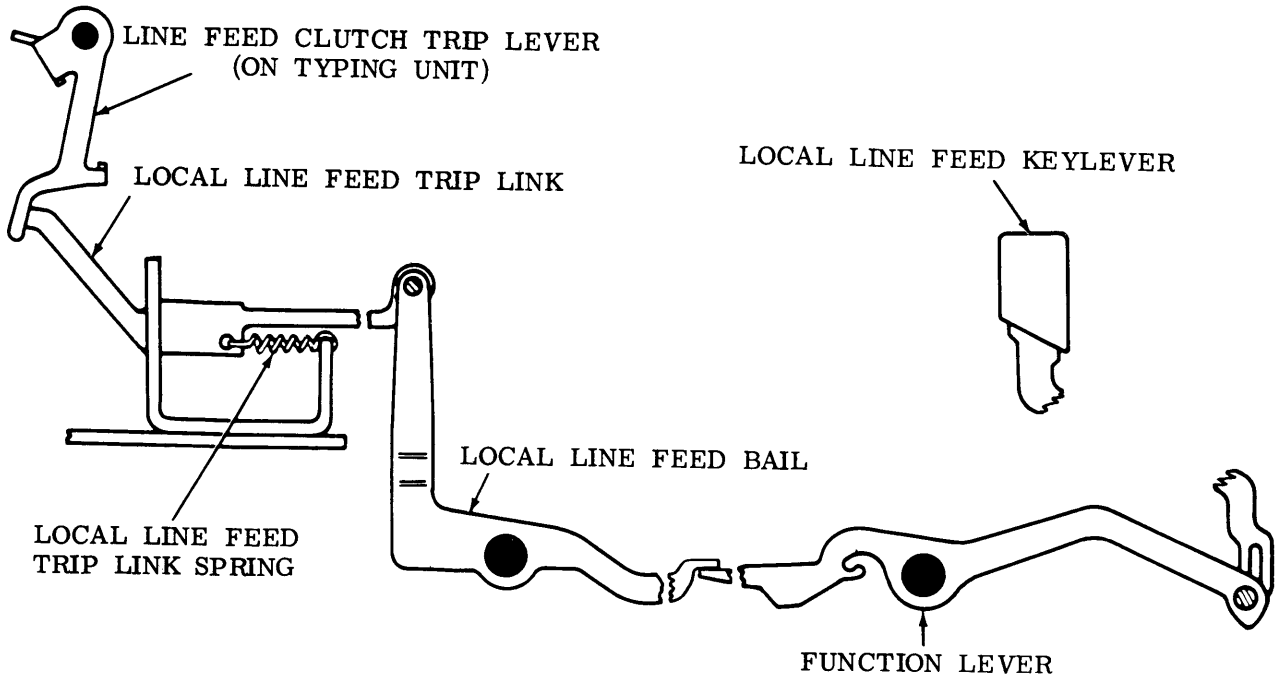

Figure 12 - Local Line Feed Mechanism

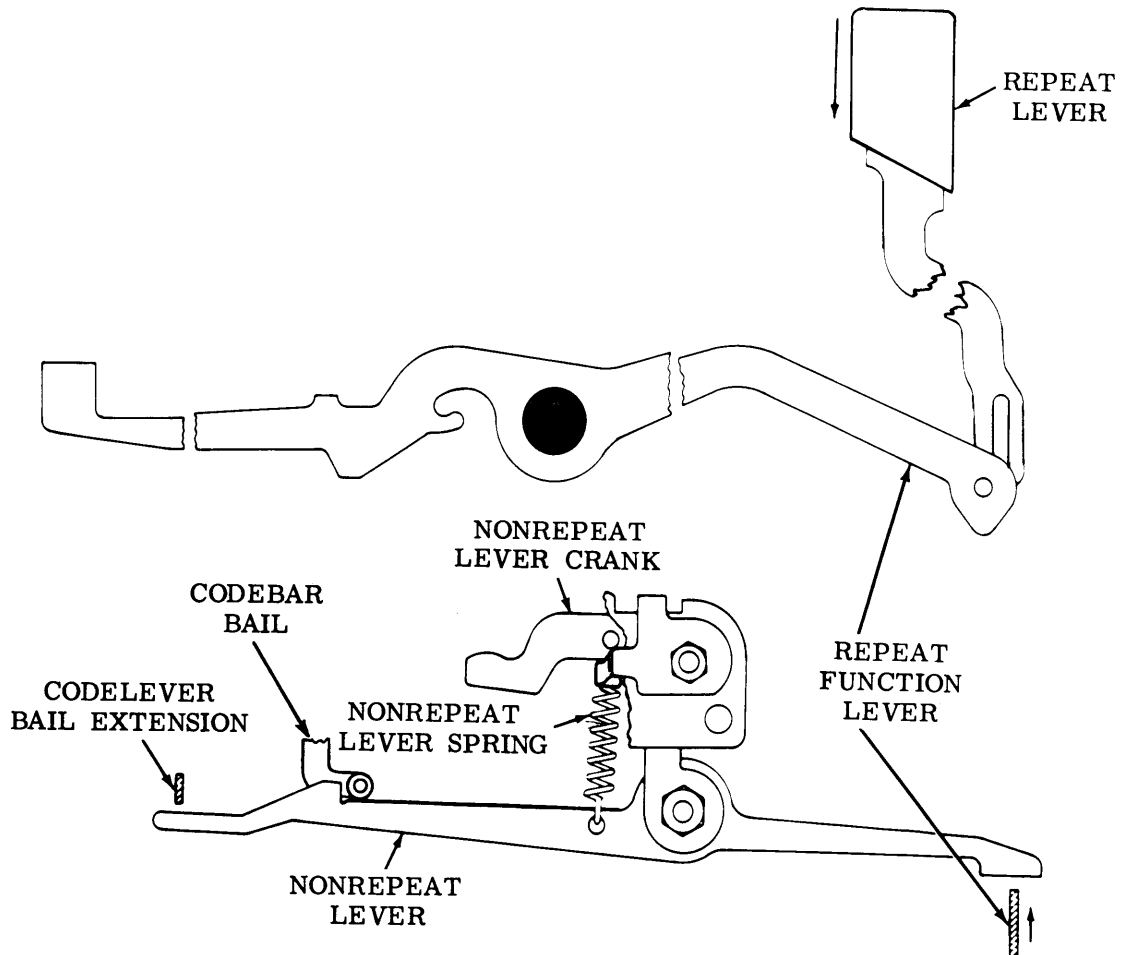

Figure 13 - Repeat Mechanism

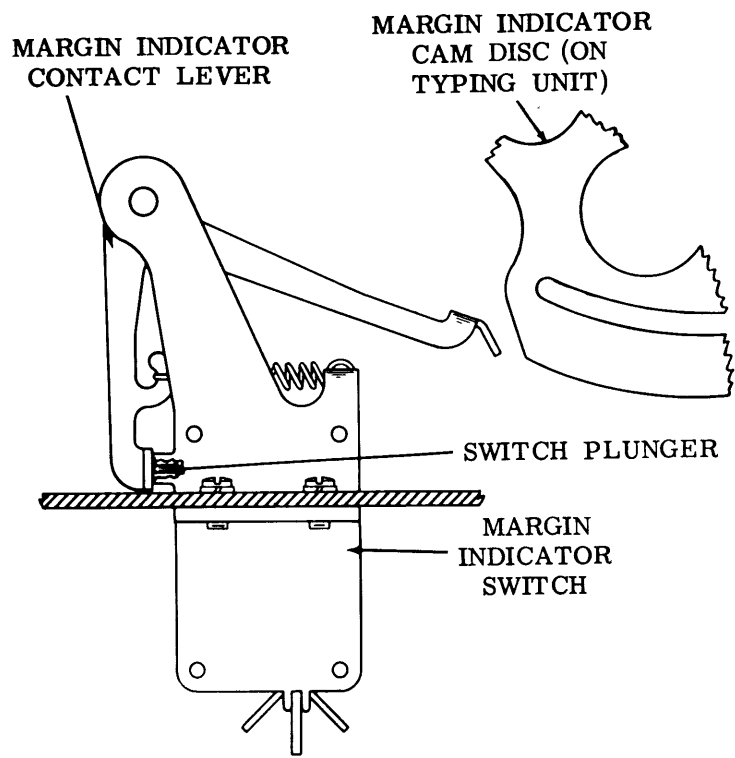

Figure 14 - Margin Indicator Mechanism

35 KEYBOARD AND BASE FOR KEYBOARD SEND-RECEIVE AND RECEIVE-ONLY SETS
 LUBRICATION

CONTENTS	PAGE
1. GENERAL.	1
2. KEYBOARD.	2
Codebar bail mechanism	10
Codebar mechanism	6
Code lever mechanism	5
Code lever universal bail.	11
Contact box.	8
Clutch tripbar mechanism	5
Function clutch mechanism	8
Function lever mechanism.	5
Intermediate gear mechanism.	12
Keyboard clutch.	9
Keylever mechanism.	4
Local carriage return mechanism.	6
Local line feed mechanism.	9
Locking bail mechanism	10
Margin indicating mechanism.	8
Nonrepeat lever mechanism.	7
Shaft mechanism	9
Spacebar mechanism.	4
Transfer bail mechanism.	8
Transfer lever mechanism.	7
Universal bail latchlever.	11
3. BASE.	12
Local carriage return mechanism (base).	14
Local line feed mechanism (base)	13

lubricate to make certain that all points receive lubrication. The following lubrication schedule should be followed thereafter.

Operating Speeds in Words per Minute	Lubrication Interval
60	3000 hours or 1 year*
75	2400 hours or 9 months*
100	1500 hours or 6 months*
150	1000 hours or 6 months*

*Whichever occurs first.

1. GENERAL

1.01 This section is reissued to add engineering changes and to update format. Since this is a general revision, the marginal arrows, used to indicate changes, have been omitted.

1.02 The 35 keyboard with or without an answer-back should be lubricated as directed in Par. 2. The lubrication for a 35 base with or without an answer-back is covered in Par. 3. The figures indicate points to be lubricated and the kind and quantity of lubricant to be used. Lubricate the unit just prior to placing it in service. After a few weeks in service, re-

1.03 Use KS7470 oil at all locations where the use of oil is indicated. Use KS7471 grease on all surfaces where grease is indicated.

1.04 All spring wicks and felt oilers should be saturated. The friction surfaces of all moving parts should be thoroughly lubricated. Overlubrication, however, which will permit oil or grease to drip or be thrown on other parts, should be avoided. Special care must be taken to prevent any oil or grease from getting between electrical contacts.

1.05 Apply a thick film of grease to all gears.

1.06 Apply oil to all cams, including the camming surfaces of each clutch disc.

1.07 The photographs show the paragraph numbers referring to particular line drawings of mechanisms and where these mechanisms are located on the unit. Parts in the line drawings are shown in an upright position unless otherwise specified.

1.08 The illustration symbols indicate the following lubrication directions:

- O1 Apply 1 drop of oil.
- O2 Apply 2 drops of oil.
- O3 Apply 3 drops of oil, etc.
- G Apply thin film of grease.
- SAT Saturate (felt oilers, washers, wicks) with oil.

2. KEYBOARD

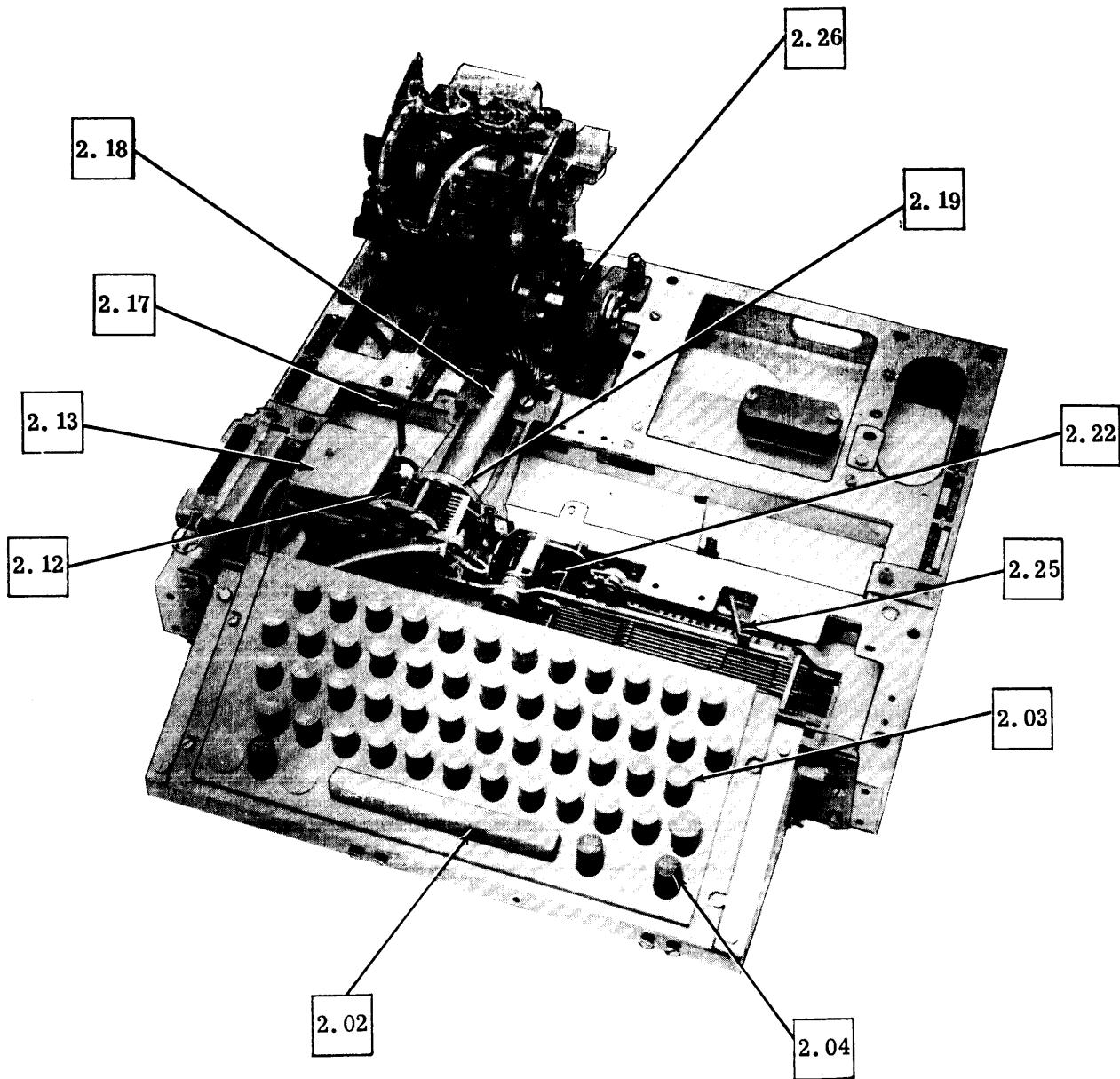

(Front View)

Figure 1 - Keyboard for Send-Receive Set

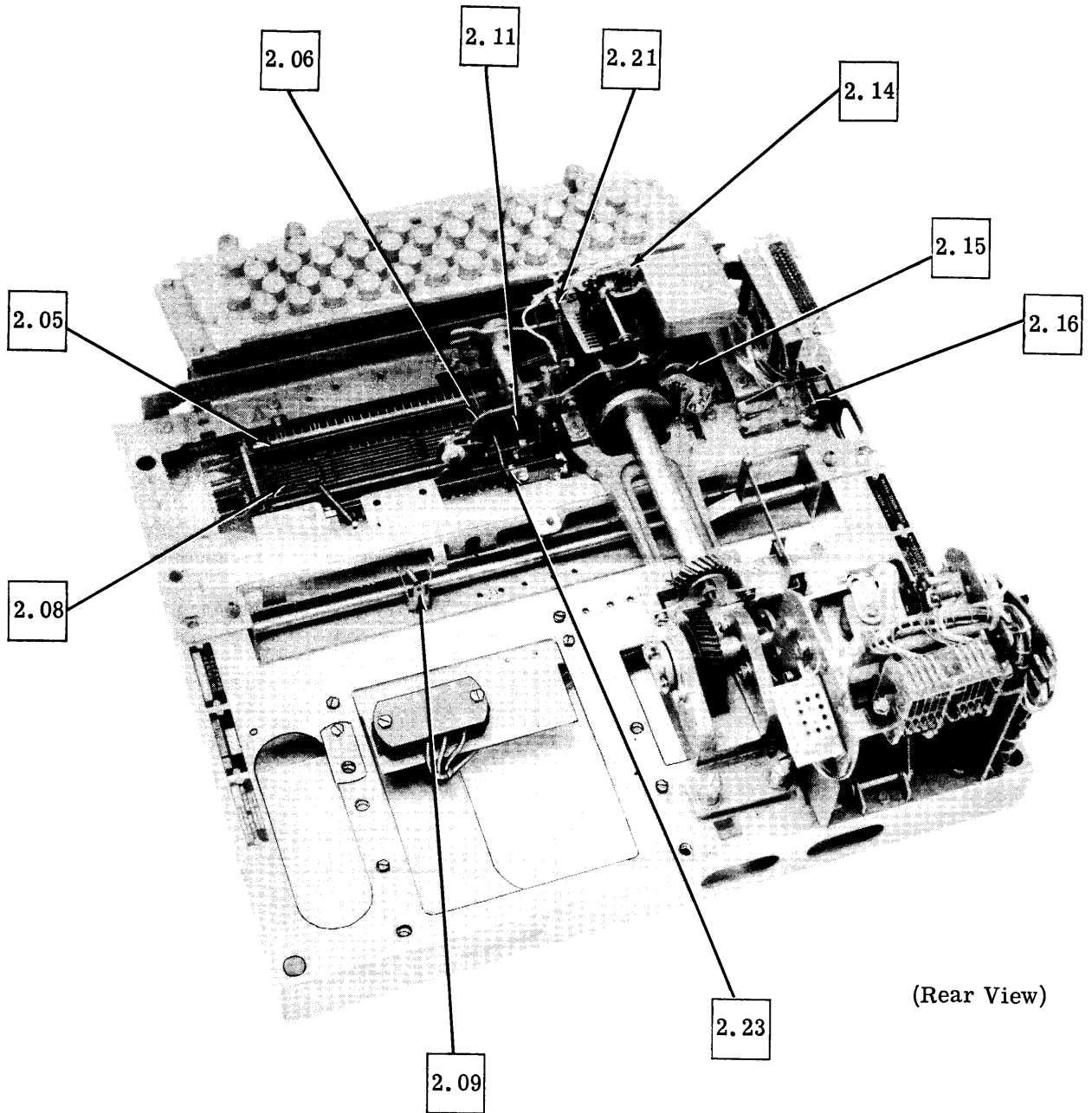
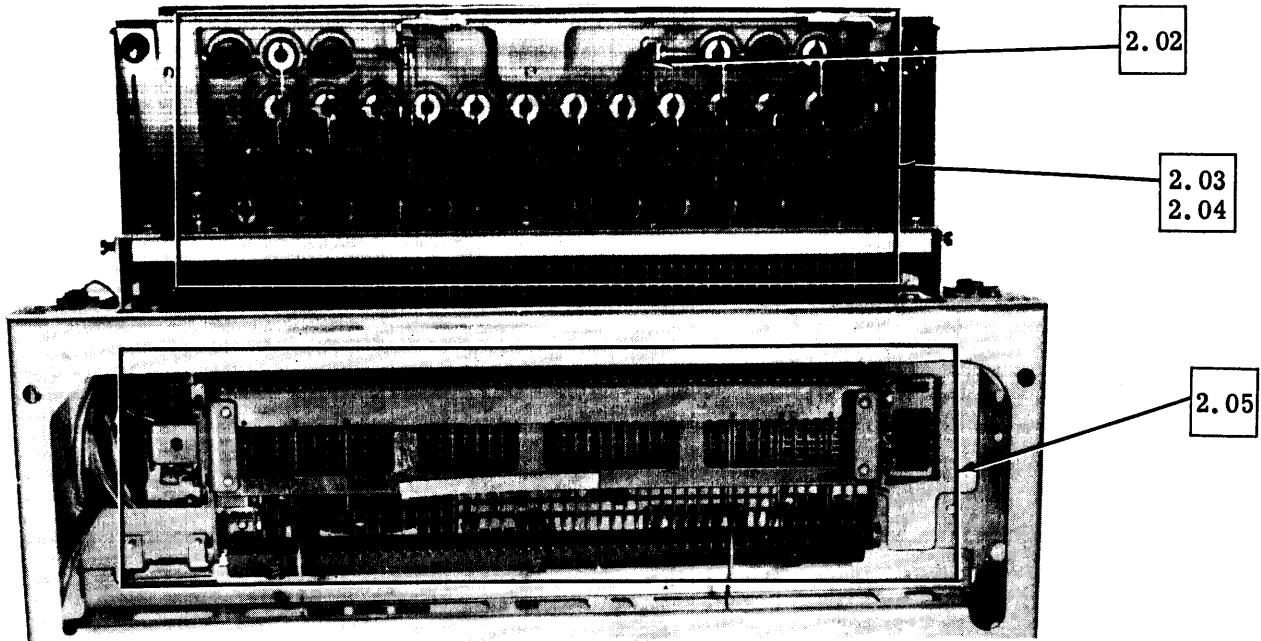

Figure 2 - Keyboard for Send-Receive Set

SECTION 574-221-701TC

2.01 Keyboard



REST KEYBOARD BOTTOM SIDE UP

2.02 Spacebar Mechanism

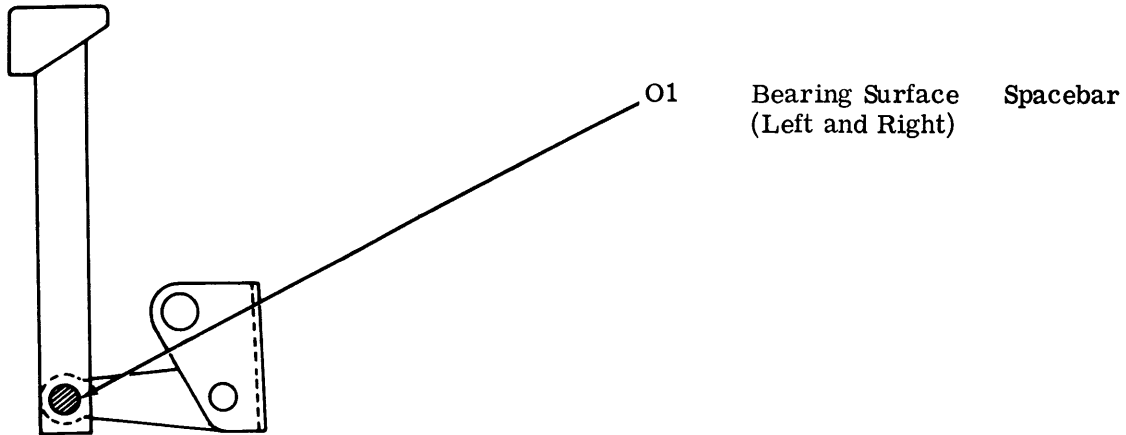

2.03 Keylever Mechanism

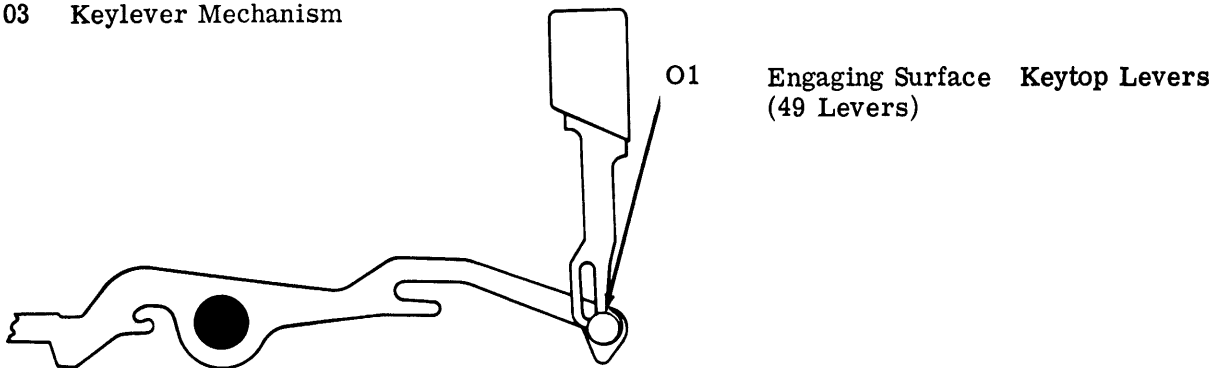

2.04 Function Lever Mechanism

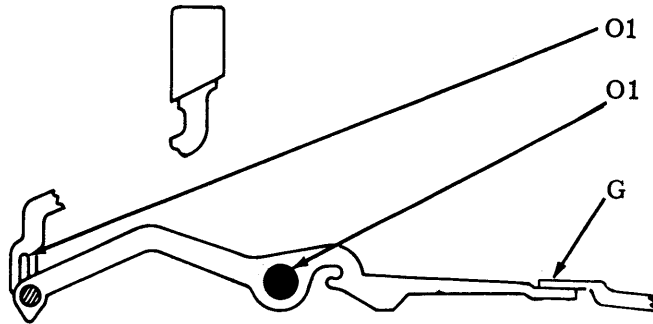

- O1 Engaging Surface Keylever
- O1 Bearing Surface Function Lever
- G Contact Surface Lever

2.05 Code Lever Mechanism

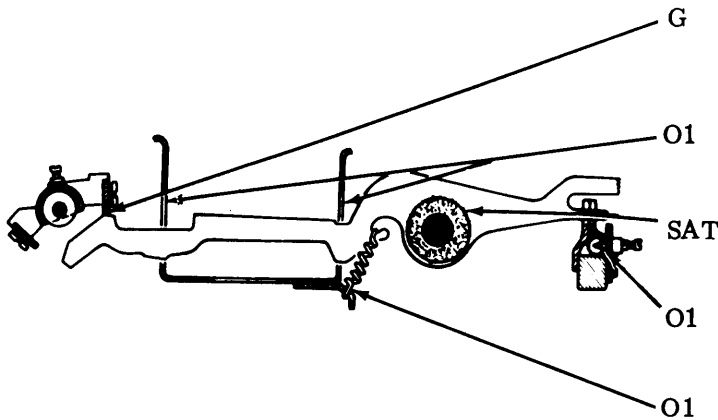

- G Contacting Surface (32 Levers) Code Lever Universal Bail
- O1 Guide Slots (46 Levers) Code Levers
- SAT Felt Washers (8 Washers) Code Lever Shaft
- O1 Bearing Surface (47 Wedges) Lock Ball Track
- O1 Hooks-Each End (50 Springs) Spring

2.06 Clutch Tripbar Mechanism

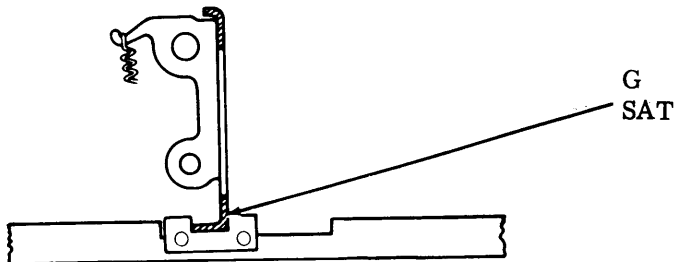

- G Slot Clutch Tripbar
- SAT Wear Plate

SECTION 574-221-701TC

2.07 Keyboard Codebars

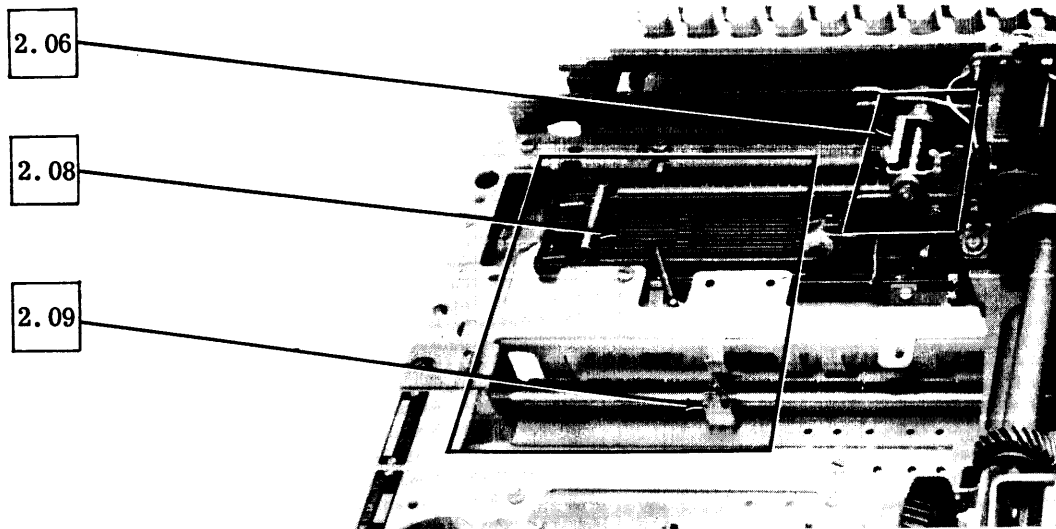

2.08 Codebar Mechanism

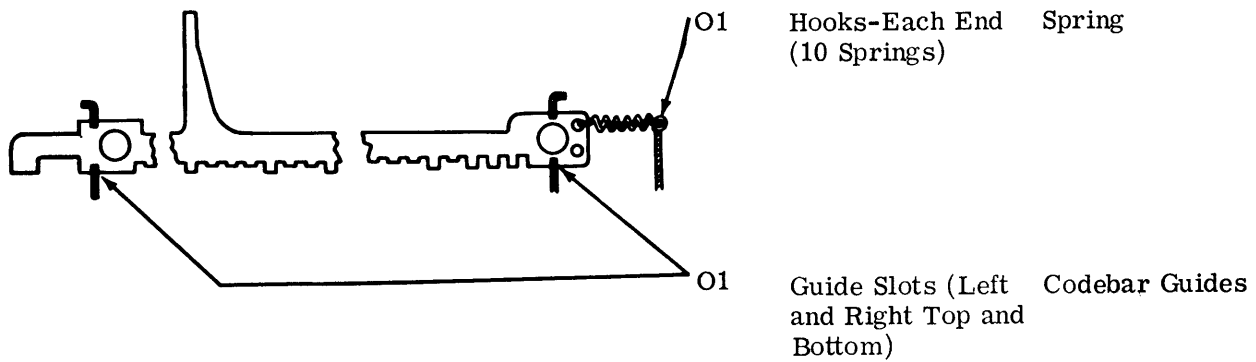

2.09 Local Carriage Return Mechanism

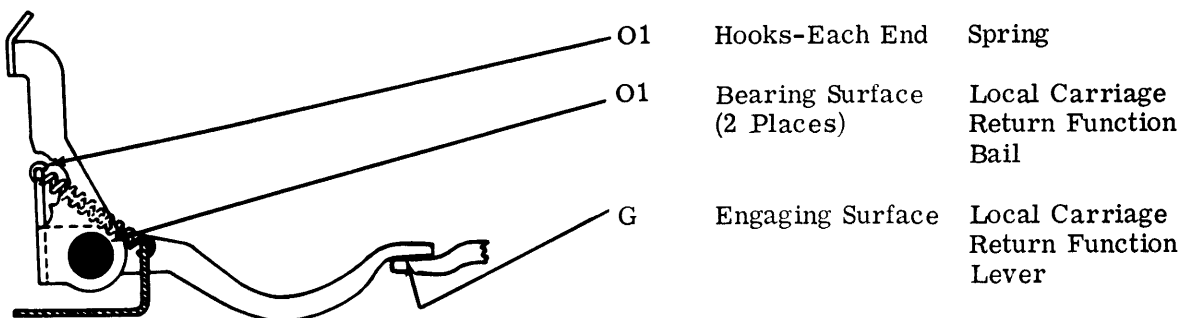

2.10 Keyboard Signal Generator

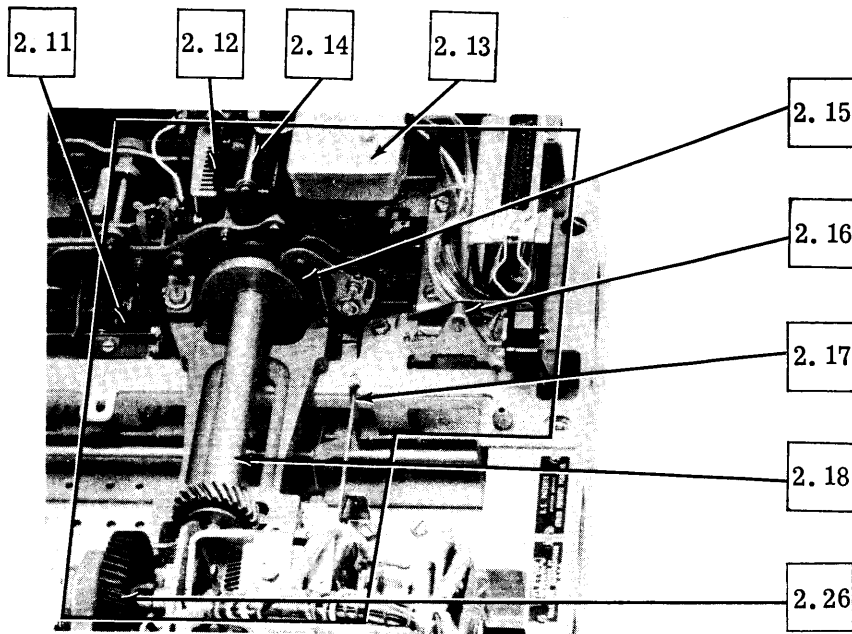

(Rear View)

2.11 Nonrepeat Lever Mechanism

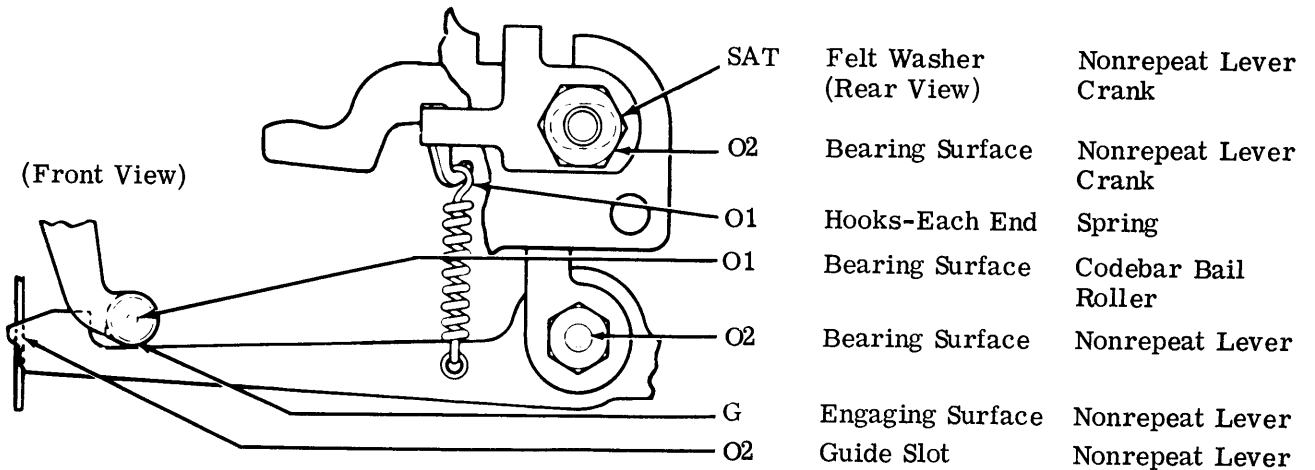

2.12 Transfer Lever Mechanism

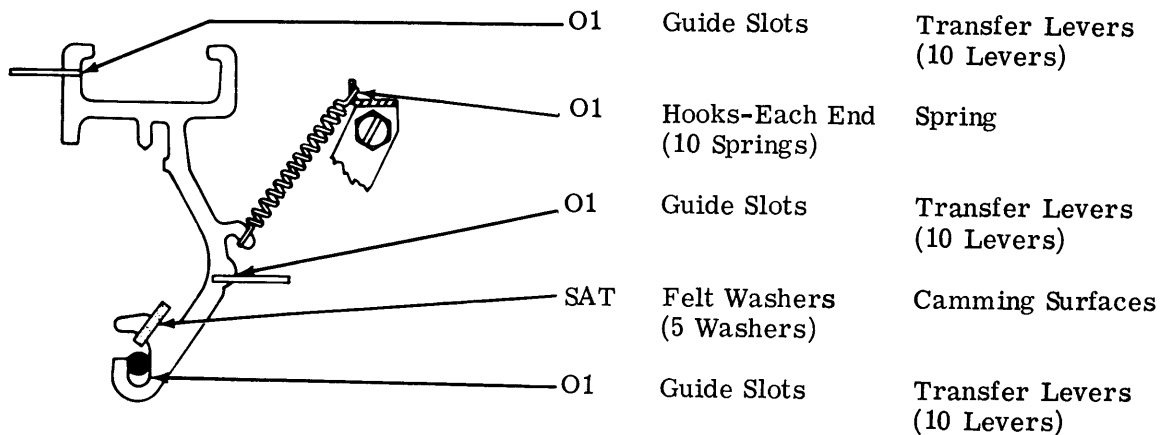

SECTION 574-221-701TC

2.13 Contact Box

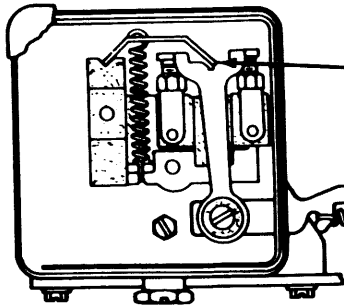

- G Engaging Surface Contact Toggle
- O1 Hooks-Each End Spring

DISASSEMBLY: REMOVE NUT AND LOCKWASHER SECURING CONTACT BOX COVER AND REMOVE COVER.

Note: The marking **DO NOT OIL** on the signal contact box cover should be interpreted literally. Portions of the mechanism should be greased as indicated, but no oil should be used.

CAUTION: GREASE SPARINGLY — KEEP CONTACTS FREE OF OIL OR GREASE.

2.14 Transfer Bail Mechanism

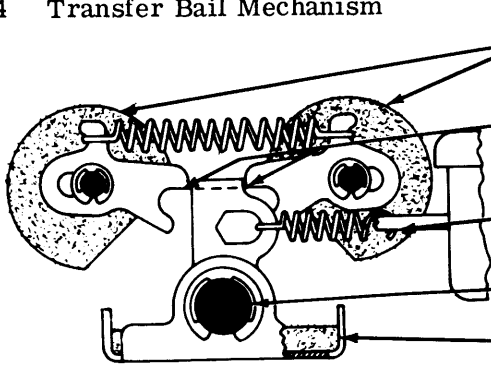

- SAT Felt Washers (2 Washers) Latches
- G Engaging Surface Transfer Bail
- O1 Hooks-Each End (2 Springs) Spring
- O2 Bearing Surface Transfer Bail
- SAT Oil Wick Transfer Bail

2.15 Function Clutch Mechanism

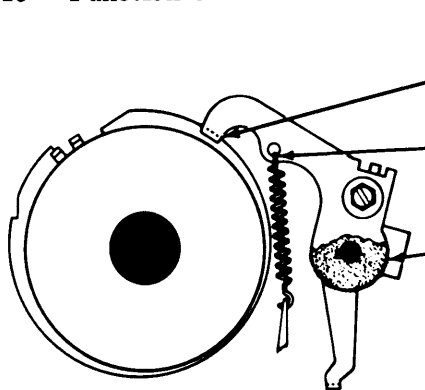

- O2 Latching Surface Clutch Stop Lever and Clutch Latch-lever
- O1 Hooks-Each End (2 Springs) Spring
- SAT Felt Washers (2 Front and Rear) Clutch Tripbail

2.16 Margin Indicating Mechanism

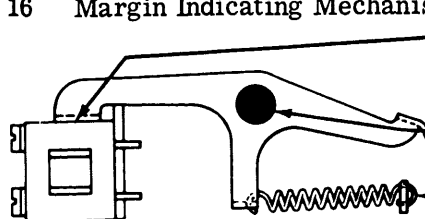

- O1 Engaging Surface Margin Indicator Switch
- O1 Bearing Surface Switch Lever
- O1 Hooks-Each End Spring

2.17 Local Line Feed Mechanism

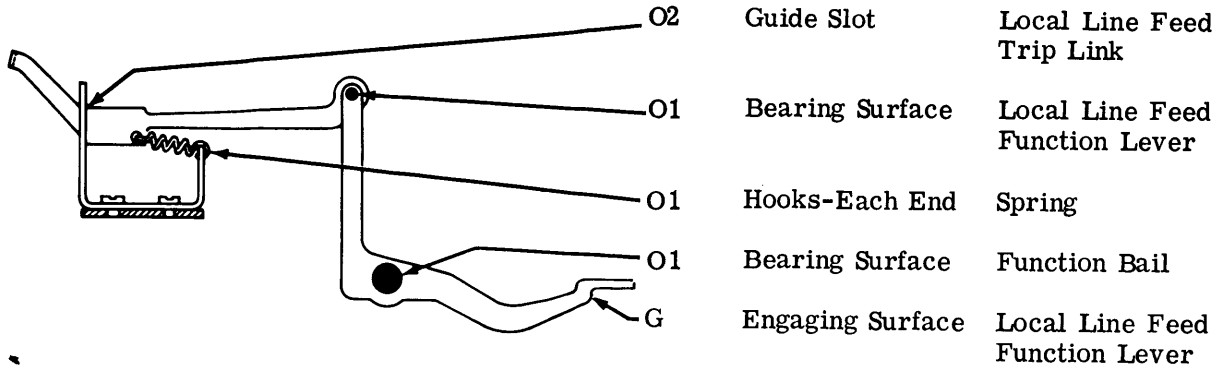

2.18 Shaft Mechanism

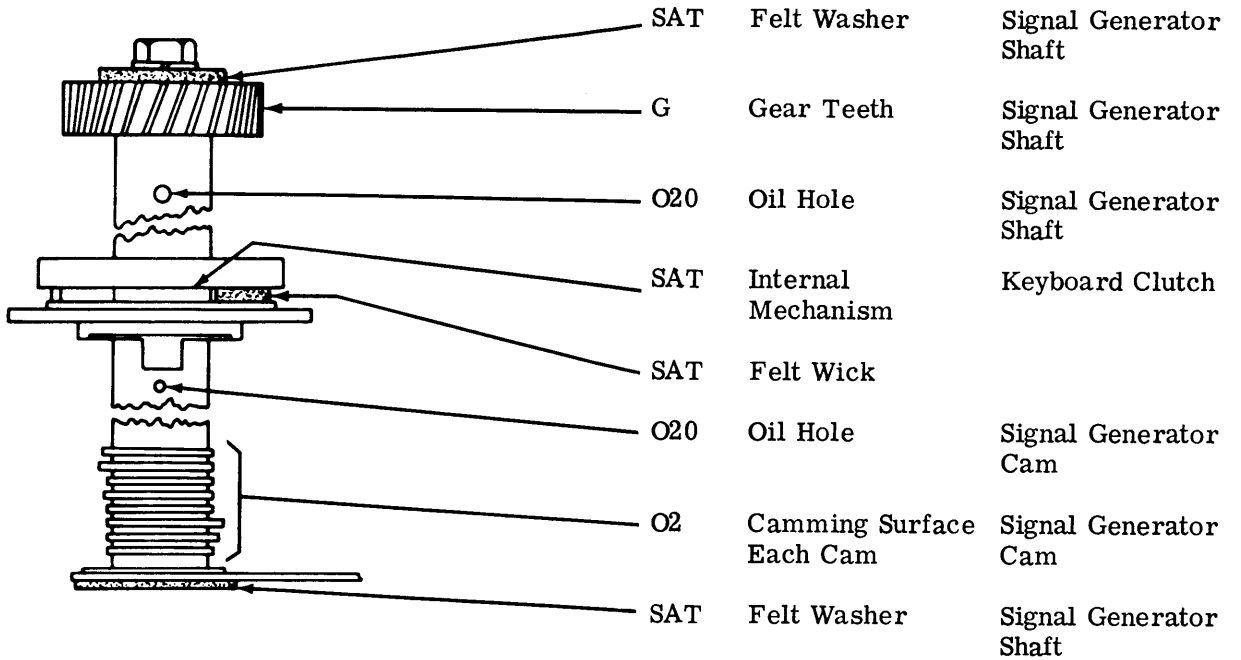

2.19 Keyboard Clutch

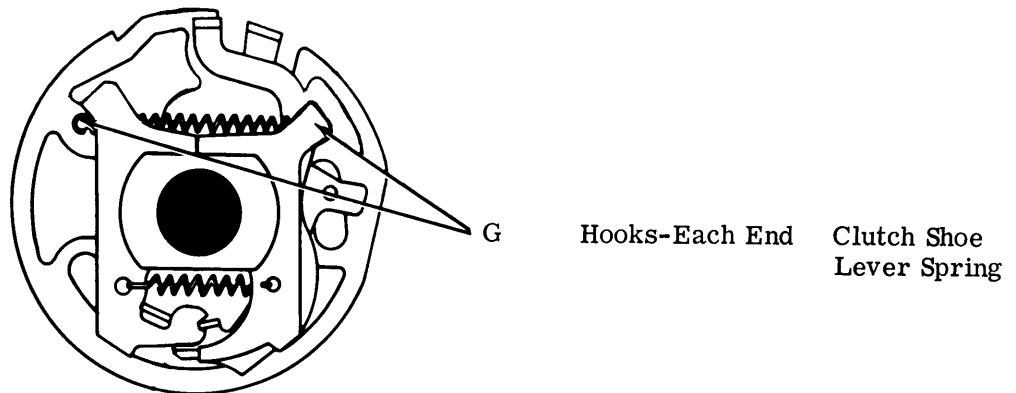

SECTION 574-221-701TC

2.20 Keyboard and Signal Generator

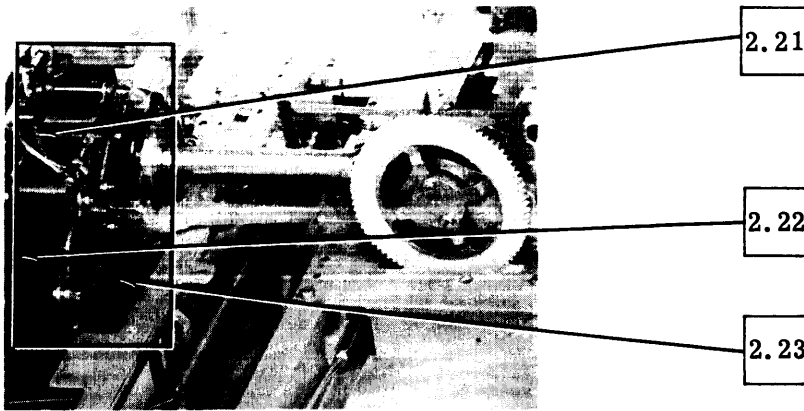

2.21 Locking Bail Mechanism

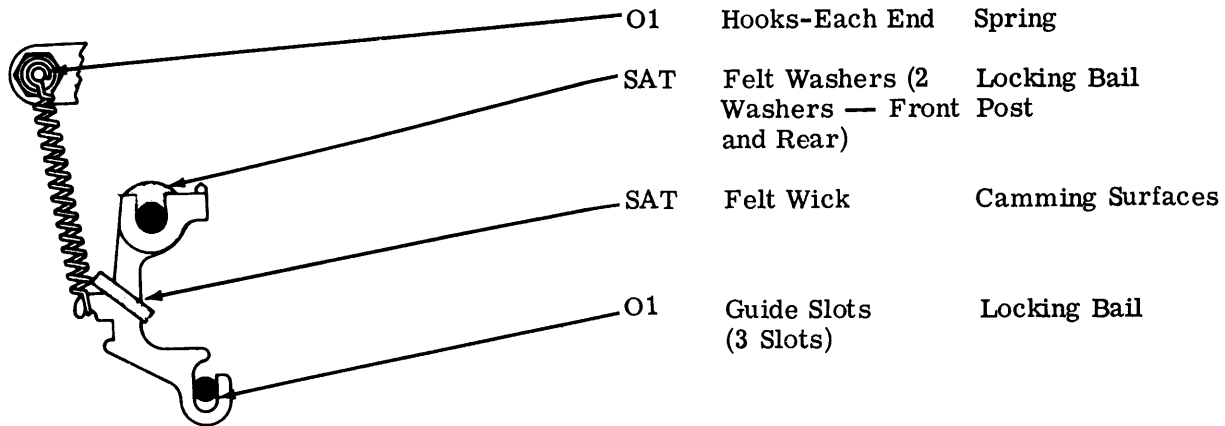

2.22 Codebar Bail Mechanism

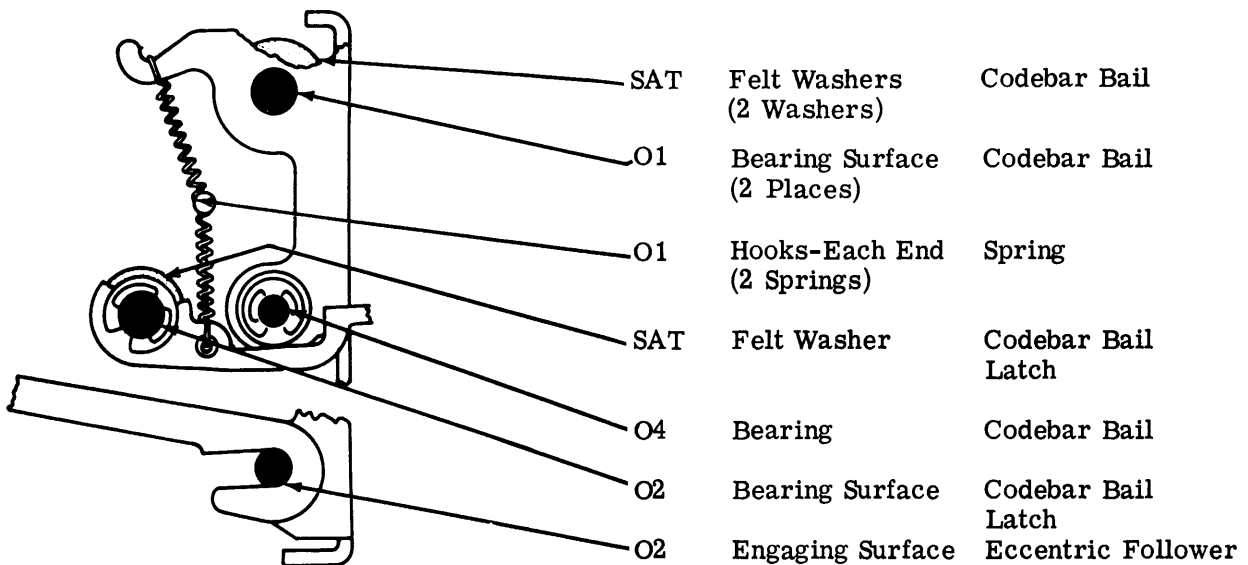

2.23 Universal Bail Latchlever

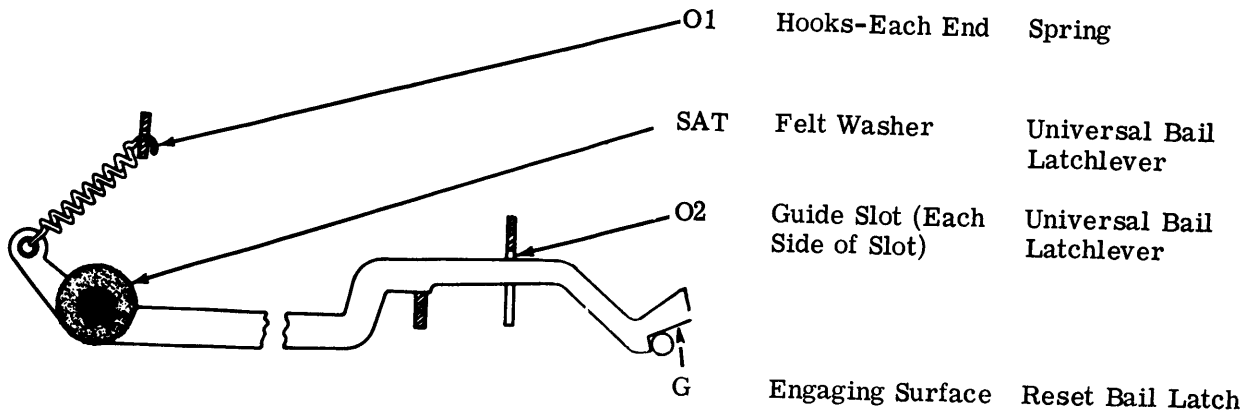

2.24 Keyboard Code Levers

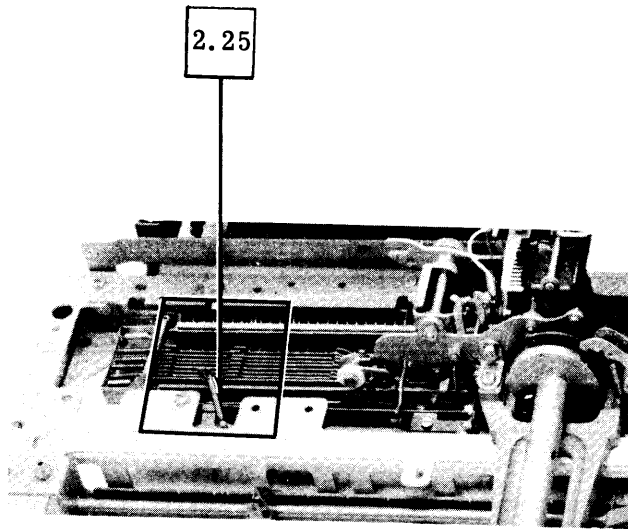

2.25 Code Lever Universal Bail

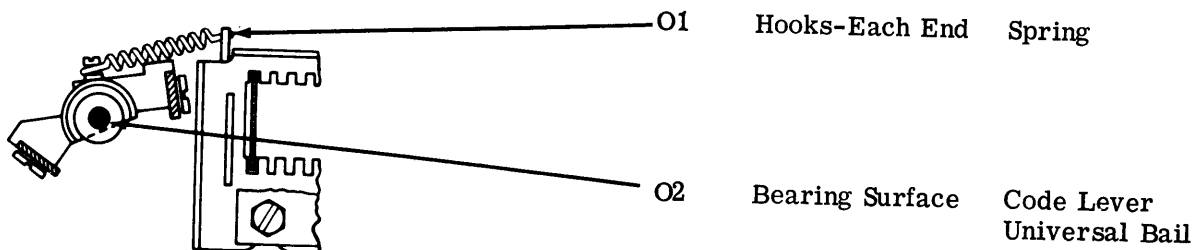

2.26 Intermediate Gear Mechanism

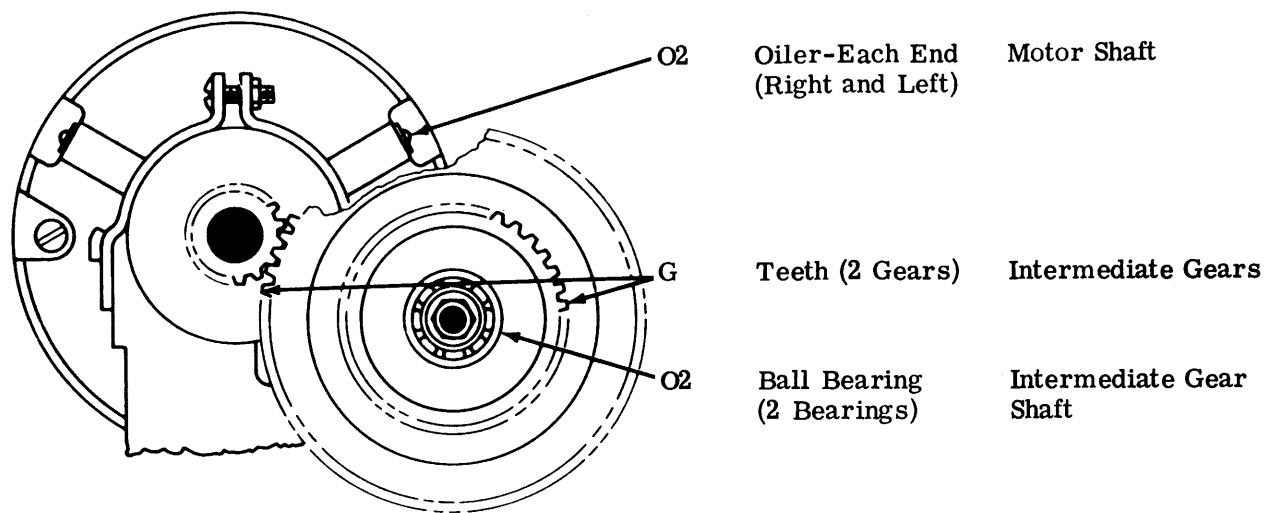

3. BASE

THE LUBRICATION REQUIREMENTS IN PAR. 2.26 PLUS THOSE SHOWN IN PAR. 3.01 AND PAR. 3.02 CONSTITUTE THE LUBRICATION FOR A BASE.

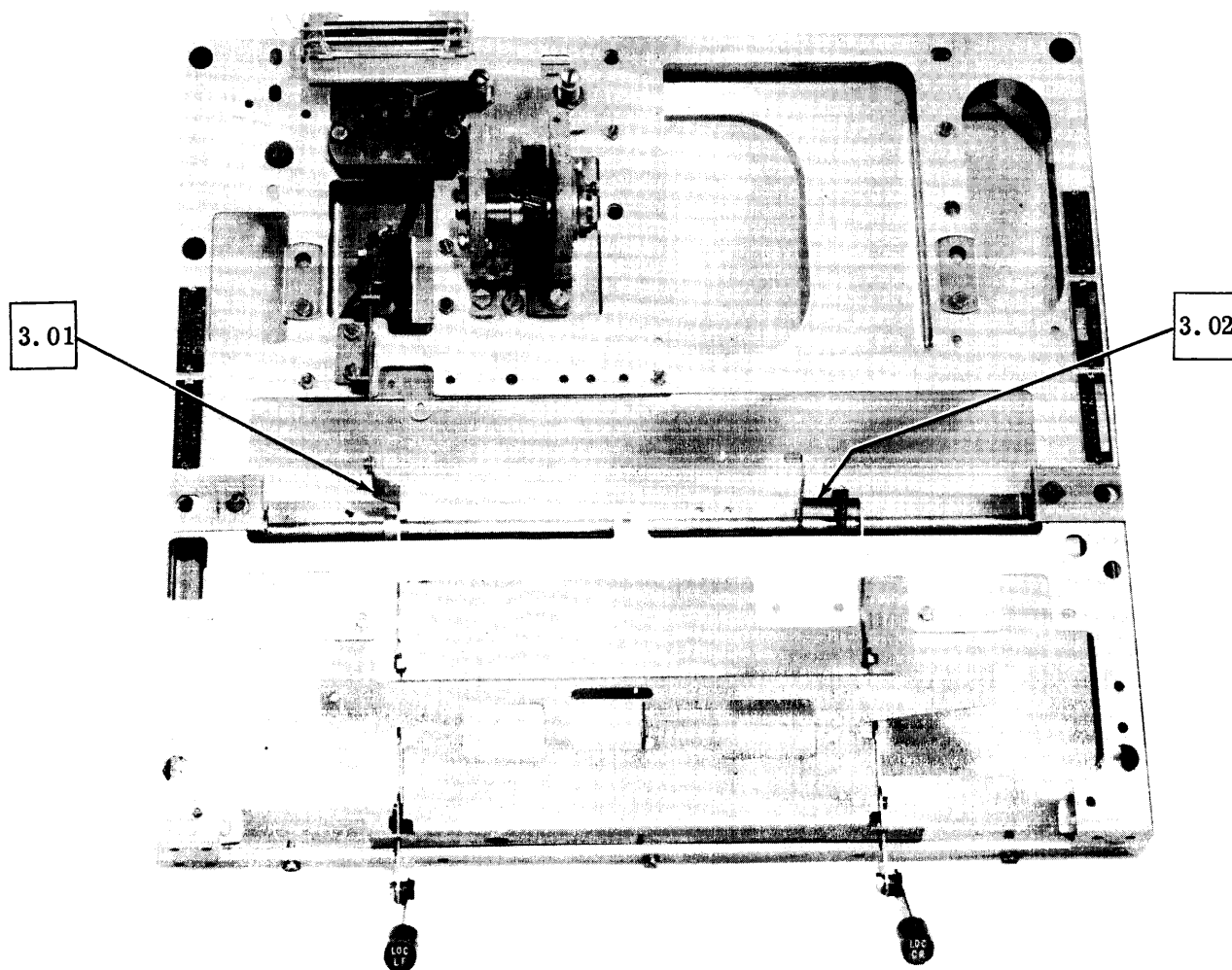
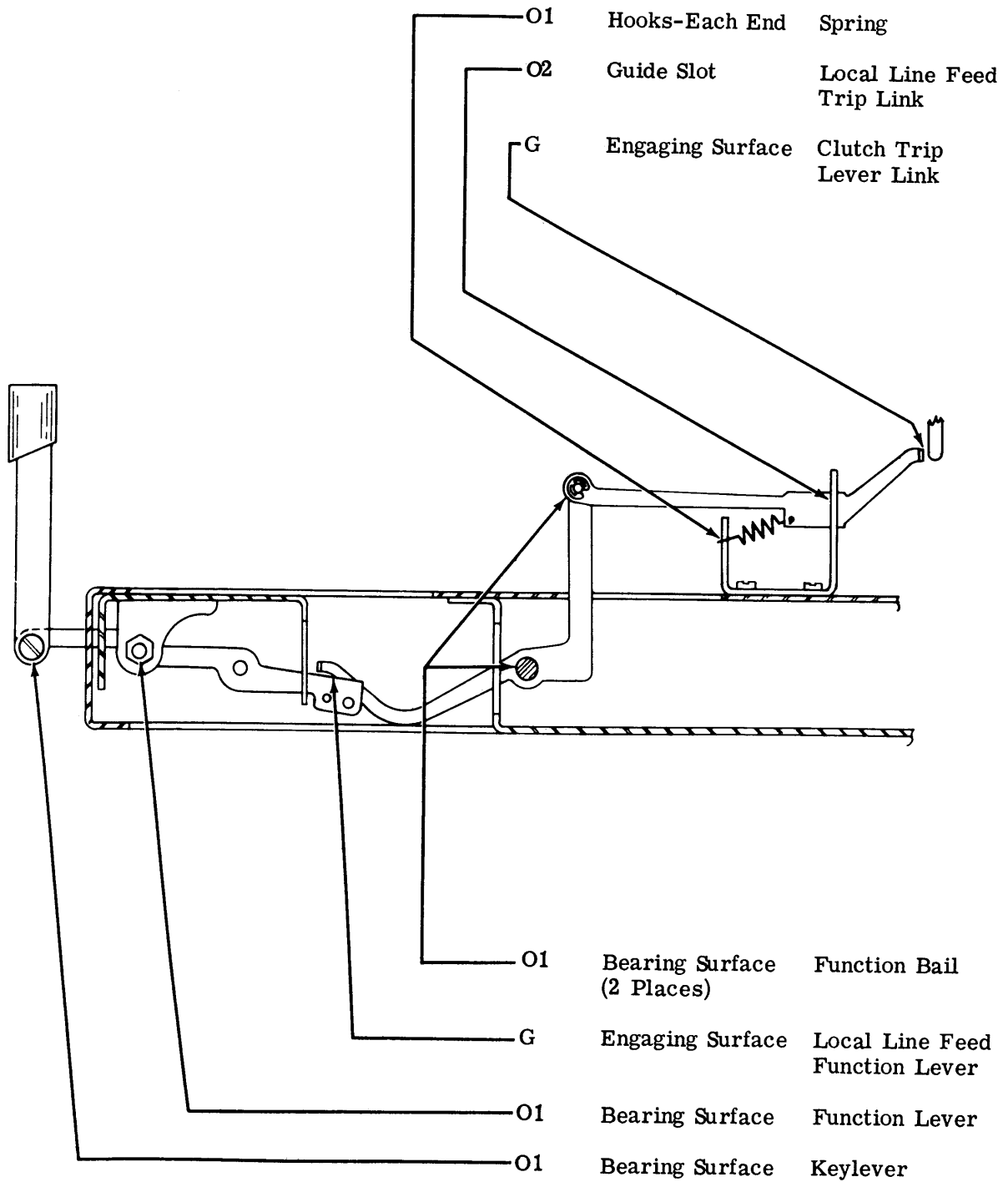

Figure 3 - Receive-Only Base

3.01 Local Line Feed Mechanism (Base)



SECTION 574-221-701TC

3.02 Local Carriage Return Mechanism (Base)

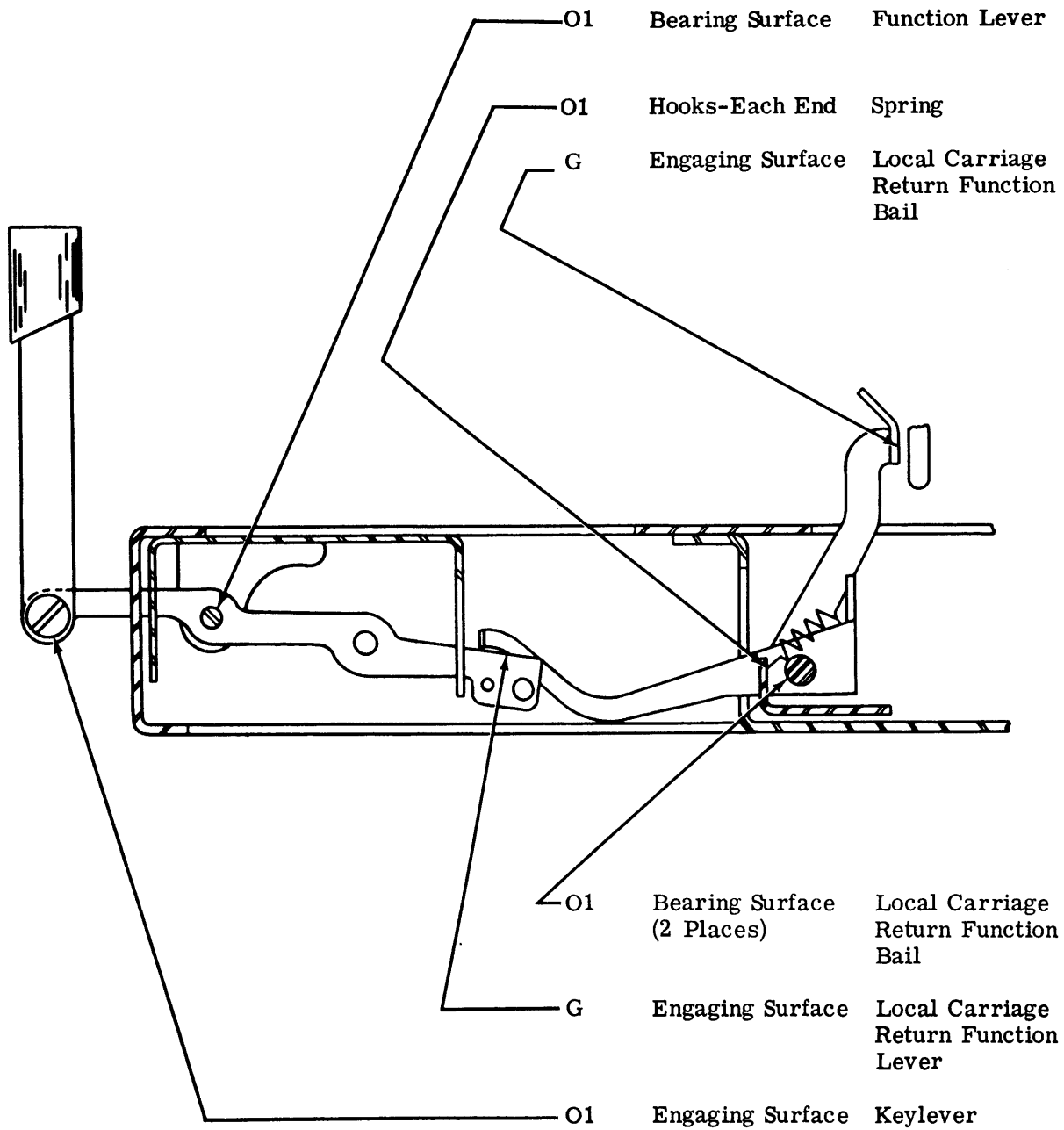

35 KEYBOARD FOR KEYBOARD SEND-RECEIVE SET
DISASSEMBLY AND REASSEMBLY

CONTENTS	PAGE	
1. GENERAL	1	1.06 Avoid loss of springs in disassembly by holding one spring loop with the left hand while gently removing the opposite loop with a spring hook. Do not stretch or distort springs in removing them.
2. DISASSEMBLY AND REASSEMBLY . .	1	1.07 Raise cabinet lid or enclosure cover (after removing the control panel bezel) and remove the typing unit from its base by removing the four screws that secure it to its keyboard or base. Remove the cable plug connector from the side frame. Lift the typing unit off.
SIGNAL GENERATOR	1	Note: On sets equipped with a form supply container on the rear of the cabinet, rearward foot extensions should be in position to prevent the cabinet from tilting when any of the components are removed.
KEYBOARD	4	1.08 Remove the four TP151549 screws that secure the base to the cradle or sub-base. Disconnect the cable plug from the connector at the rear of the keyboard base. Remove the base with the motor unit still in position.
1. GENERAL		2. DISASSEMBLY AND REASSEMBLY
1.01 Disassembly, as outlined in this section, covers a procedure for removing the principal sub-assemblies which make up the unit.		2.01 In removing a subassembly from the unit, the procedure followed and the location from which parts are removed must be carefully noted so that reassembly can be done correctly. Where no specific instructions are given for reassembly, reverse the procedure used in removing it.
1.02 The technician should refer to the exploded views found in the appropriate parts literature for an illustration of the mechanism to be disassembled, for location and visual identification of parts and detailed disassembly and reassembly features.		SIGNAL GENERATOR
1.03 Most maintenance, lubrication and adjustments can be accomplished simply by removing the subject component from the cabinet. If possible, disassembly should be confined to sub-assemblies, which can, in some cases, be removed without disturbing adjustments. When reassembling the sub-assemblies, be sure to check all associated adjustments, clearances and spring tensions.		2.02 To Remove: Take cover off contact box and disconnect the signal line leads. Pull up on the line cable, with its strain relief and grommet intact, and push it aside out of the way.
1.04 If a part that is mounted on shims is removed, the number of shims used at each of its mounting screws should be noted so that the same shim pile-up can be replaced when the part is remounted.		2.03 Remove two mounting screws at front of the signal generator frame casting and one at the rear.
1.05 Retaining rings (Tru-arcs) are made of spring steel and have a tendency to release suddenly when being removed. Loss of these retainers can be minimized as follows: Hold the retainer with the left hand to prevent it from rotating. Place the blade of a suitable screwdriver in one of the slots of the retainer. Rotate the screwdriver in a direction to increase the diameter of the retainer for removal.		2.04 Hold the TP170372 universal bail back so that the TP170392 non-repeat lever clears, without stretching its spring, when the signal generator is lifted out.

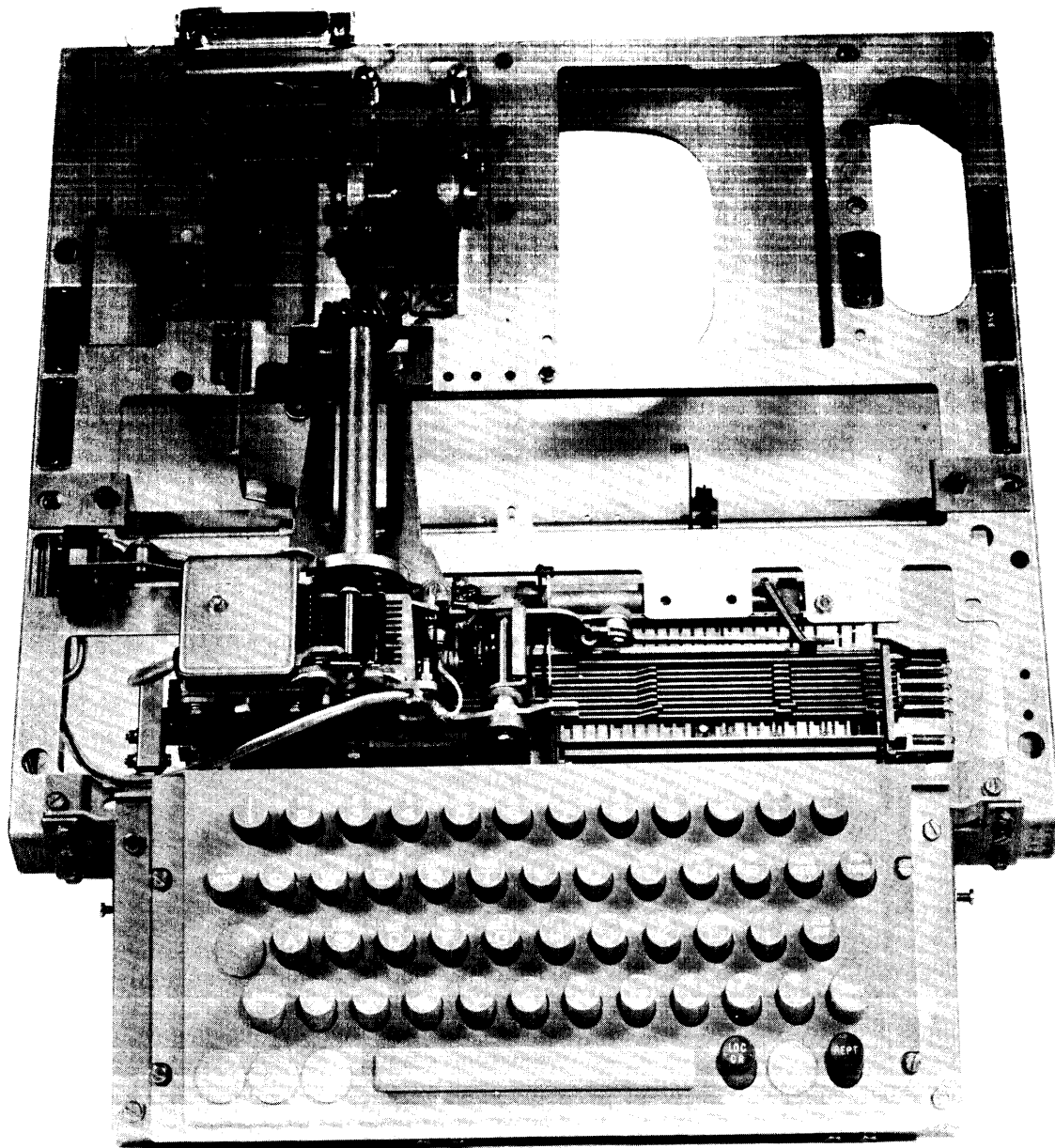

Figure 1 - 35 Keyboard for KSR Set

CAUTION: PREVENT THE NON-REPEAT LEVER FROM BEING PULLED TOO FAR DOWNWARD. IF IT IS PULLED DOWNWARD AS MUCH AS 90° FROM ITS OPERATING POSITION, THE SPRING WILL BE STRESSED BEYOND ITS ELASTIC LIMIT. MAKE SURE THE LEVER IS IN ITS SLOT BEFORE SETTING IT DOWN.

2.05 To disassemble the signal generator for replacing parts, the following procedure should be used:

- (a) Disconnect the suppressor leads at the contact terminals.
- (b) Unhook the drive link spring. Remove the two contact box bracket mounting screws. Disengage the drive link from the transfer bail and lift the contact box off.
- (c) Remove the lock nut from the top of the phenolic block. Turn the box over and remove the two screws which secure the contact assembly in place. Slip the drive link out through the slot in the contact box and disconnect the link from the contact toggle by removing the connecting screw and insulator bushing.
- (d) To remove the TP154034 clutch stop arm, unhook the spring and unscrew the adjusting screw.
- (e) To remove the TP170392 non-repeat lever, unscrew the lock nut and remove the shoulder mounting screw.
- (f) To remove the TP154010 transfer bail, unhook the drive link spring. Remove the lock nut at the end of the transfer bail shaft on the front plate of the signal generator. Disengage the drive link from the transfer bail and pull the bail and shaft toward the rear.
- (g) To remove the TP154036 detent plate, after the transfer bail and shaft have been taken out, remove the two detent plate mounting screws on the front plate of the signal generator. The detent plate assembly can then be lifted out of place. The TP156516 detent latches can then be taken off by removing the retainer from the studs.
- (h) To remove the TP158268 code bar bail latch, remove the retainer from the end of its stud. Unhook the spring from the latch. Strip the latch off to allow the code bar bail

to move to its extreme right hand position. Work the latch to the front off its stud.

(i) To remove the TP154236 universal bail latch lever after the non-repeat lever mechanism is removed, unhook the spring. Remove the mounting screw and eccentric bushing. Move the latch lever toward the rear to extract it from its slot.

(j) To remove the TP160090 transfer levers:

(1) Trip the clutch and rotate the shaft approximately 270 degrees. Unhook the locking bail spring. The locking bail can be dropped down and unhooked from the guide post under the cam. Reach underneath the assembly and turn the locking bail clockwise. It may be necessary to move the gear back and forth to get clearance to drop the locking bail out of the upper guide post through the bottom of the assembly.

(2) Remove the screws from the upper right hand TP170391 transfer lever guide, and rotate the guide about the locking bail spring post so that it does not interfere with removing the transfer lever.

(3) Remove the transfer lever springs. Remove the TP151631 screw and lock washer from the TP154094 right angle clamp in back of rear plate. Remove the TP3599 nut and lock washer from the TP192534 locking bail post. Remove the nut from the rear end of the TP170388 guide post. Loosen to the end of the threads the nut on the rear end of TP154015 code bar bail mounting post. Remove the TP192589 stop pin.

(4) Drop the transfer lever. Reach under the cam with a pair of tweezers and remove the oil wicks.

(5) Unhook the transfer levers from the lower guide post and pull them up out of the assembly one at a time from rear to front. If the same levers are to go back into the assembly, number them in a manner to insure replacement in the same sequence.

(k) To remove the cam shaft assembly:

(1) With the locking bail removed, remove the two screws from the TP154101

SECTION 574-221-702

rear gear plate, and the nut from the front end of the shaft.

(2) Hold the stop lever and latch lever out of the way and pull rearward on the shaft assembly to disengage it from the front plate. The entire cam clutch and shaft assembly can be removed toward the rear by gently rotating rearward. The eccentric follower arm and spacer washers will fall free and must be carefully positioned when reassembling.

(3) To remove the cam (with clutch) from the shaft, disengage the clutch by holding the clutch shoe lever against the stop lug and sliding the cam off the shaft. For ease of reassembly, tie the clutch shoe lever and stop lug together with wire. Place the shaft in first.

(4) After the cam and clutch assembly are removed, the clutch itself may be disassembled from the cam. To do so, carefully remove the springs. Remove the clutch shoes. Remove the two clamp screws in the clutch disk, and then remove the disk. The clutch disk can then be removed from the cam by removing the two screws securing it to the cam.

Note: If a new cam is being installed, the clutch shoes and disk should be tried in their respective grooves to see that they move freely before reassembly.

(1) To remove the TP154240 code bar bail, unhook its spring. Remove the lock nut at the front and rear ends of the TP154015 pivot shaft. Remove the lock nut from the rear end of the TP170388 transfer lever guide post. Remove the nut from the rear end of the TP192534 upper locking bail guide post (if these nuts have not already been removed). Pull the rear plate toward the rear until the code bar bail pivot post clears sufficiently to be removed.

KEYBOARD

2.06 To disassemble the keyboard assembly for replacing parts, two procedures may be followed: (a) With keyboard removed from base; (b) With keyboard attached to base.

(a) Keyboard removed from base.

(1) To remove the keyboard from the base, remove the four screws which

hold the front frame to the front of the base.

(2) From the top of the base remove the two screws with flat washers at the right and left rear side of the code bar assembly brackets. Remove the two screws at the extreme left and right ends of the right angle bracket at the front of the code bar assembly. Remove the screw and cable clamp at the left of this bracket.

(3) When these eight screws have been removed, the keyboard assembly can be removed from the base by tipping it upward slightly at the front and pulling it forward so as to disengage the function levers. Note that all the function levers are under their corresponding function bails, so that they may be replaced correctly when reassembling.

(4) Remove the four screws from the space bar. Lift space bar out. Remove the four screws from the plastic keylever guide plate. Lift the guide plate out.

(5) To remove a keylever, hook one lug of the associated code lever, and the other lug in the slot of the keylever. A pull forward on the tool will snap the keylever from its code lever.

(6) Disconnect the TP154021 space bail link at its code lever by removing its retainer. Remove the screw at each end of the lock ball track to remove the track. The TP154080 wedgelocks may then be removed from their code levers.

(7) To remove the code bars after the signal generator has been removed, unhook the code bar springs from the spring bracket at the right end. Leave springs on code bars. Loosen the adjusting screws at the right and left end bracket. Lift the code bar guides to the top limit of their adjusting slots. Move the code bar to the right until it clears the left hand guide. Lift the code bar slightly and move it to the left until it clears the right hand guide.

(8) To remove a function lever or code lever after the keyboard assembly has been dismantled to the keylever guide assembly stage and the code bars have been removed, turn the assembly upside

- down. Remove all code lever springs. Remove the inner retainer from the pivot shaft and pull the shaft out until the levers are free. Remove the levers toward the front.
- (b) With keyboard attached to base.
- (1) To remove a keylever assembly, hook the end lug of the keylever remover over the top of its associated code lever and the other lug in the slot of the keylever. A pull forward will snap each keylever from its pivot stud on the code lever.
 - (2) To remove the lock ball channel, remove the 4-40 screws at each end of the wedge retainer plate. Loosen the clamp at the center. As the wedge retainer is removed note the number of spacer washers at each end. Remove the mounting screws at each end of the lock ball bar assembly to free it from the keyboard.
 - (3) The 53 lock balls can be removed by taking the adjusting screw out at the end channel and permitting the balls to roll out.
 - (4) Remove the pivot screws which fasten the space bar assembly to the space bar bail. Remove the hold-down screw located under the space bar, and the two screws at each end of the keylever guide plate. Work the guide plate upward and off the keylevers.
 - (5) To remove the universal bail, set the keyboard up vertically on its rear side using the motor as a prop. Remove the bail spring. Loosen the lock nut on each universal bail pilot screw. Back off one pilot screw and lift the bail out.
 - (6) To reinstall the keylever guide plate with the keylevers attached, flip them all toward the rear. Place the front edge of the guide plate on the frame and push the keylevers of the front row into their respective holes. Then work in the second, third and fourth rows in a similar manner.

35 ELECTRICAL SERVICE UNIT

GENERAL DESCRIPTION AND PRINCIPLES OF OPERATION

CONTENTS	PAGE
1. GENERAL	1
2. DESCRIPTION	1
3. PRINCIPLES OF OPERATION	3
GENERAL	3
SELECTOR MAGNET DRIVER	6
LINE-LOCAL RELAY	6
ELECTRICAL MOTOR CONTROL	6
MOTOR CONTROL RELAY	6
REPERFORATOR CONTROL RELAY	6
AUTOMATIC TURN AROUND TRAFFIC CONTROL	6
TAPE FEED-OUT CONTROL RELAY	7
LINE-SHUNT RELAY	7
CHARACTER COUNTER SUPPRESSION	7
MODE SWITCHING COMPONENTS	7
A. Automatic	7
B. Manual	7

1.02 The 35 electrical service unit serves as an area of concentration for the wiring of 35-type apparatus and provides mounting facilities for various electrical assemblies and components.

1.03 The operational facilities provided by the electrical service unit vary, depending upon the number and complexity of functions performed by the set.

1.04 Complete operation of an electrical service unit requires connections with other components of a set with which it is used. Additional information concerning the support functions of the unit may be found in sections discussing specific components and complete sets. Only independent features in the electrical service unit are discussed in this section, under principles of operation.

1.05 The electrical service units discussed in this section are used in all models of the following sets:

- (a) 35 Receive Only (RO) Set.
- (b) 35 Keyboard Send-Receive (KSR) Set.
- (c) 35 Automatic Send-Receive (ASR) Set.
- (d) 35 Receive Only Typing Reperforator (ROTR) Set.

These sets may be utilized in a variety of installation configurations, including: private line applications, data communications networks, circuit switching networks, and computer installations.

1. GENERAL

1.01 This section has been generally revised to include information on recent 35 electrical service units. Because this issue is a general revision, marginal arrows that indicate changes have been omitted.

2. DESCRIPTION (See Figures 1, 2, and 3)

2.01 The electrical service unit consists, basically, of a rectangular, metal chassis (or container) and a number of mounting plate assemblies. Each mounting plate assembly consists of a functional group of components. They are mounted on the chassis and are interconnected, as required, with strapping.

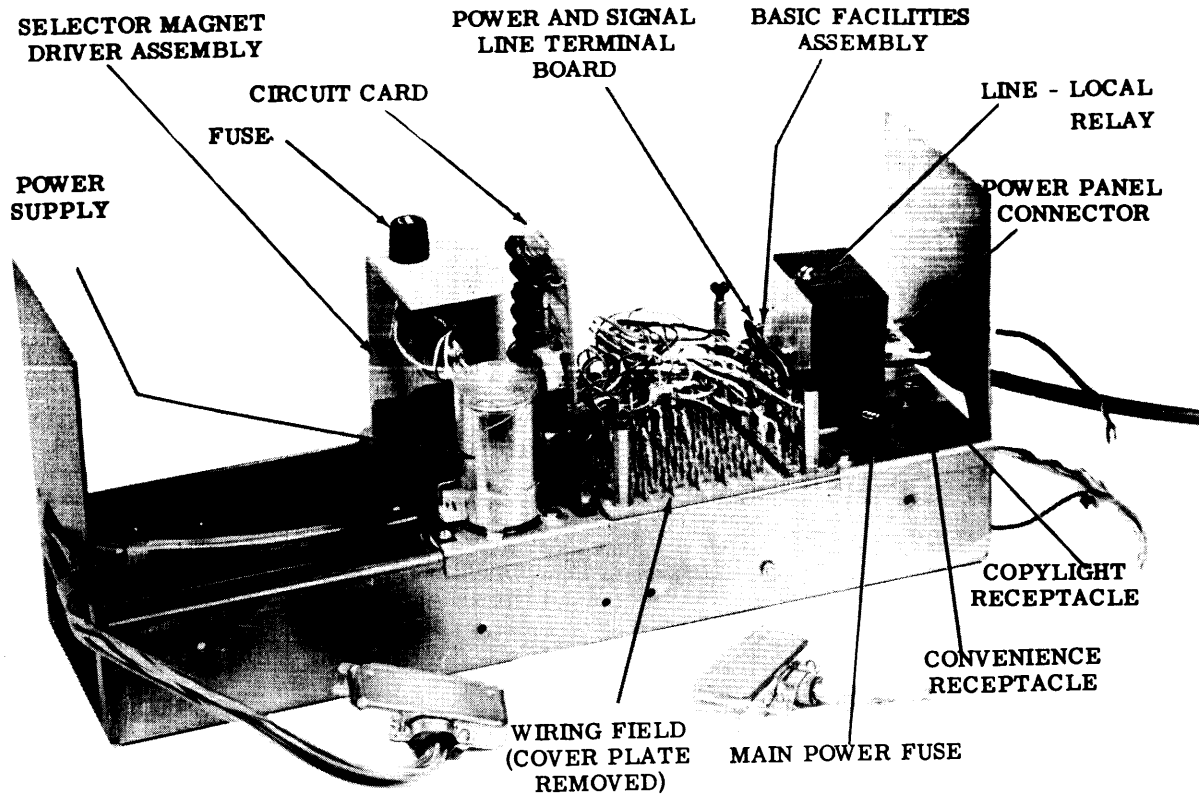

TOP VIEW

SELECTOR MAGNET DRIVER ASSEMBLY WIRING FIELD COPYLIGHT TRANSFORMER

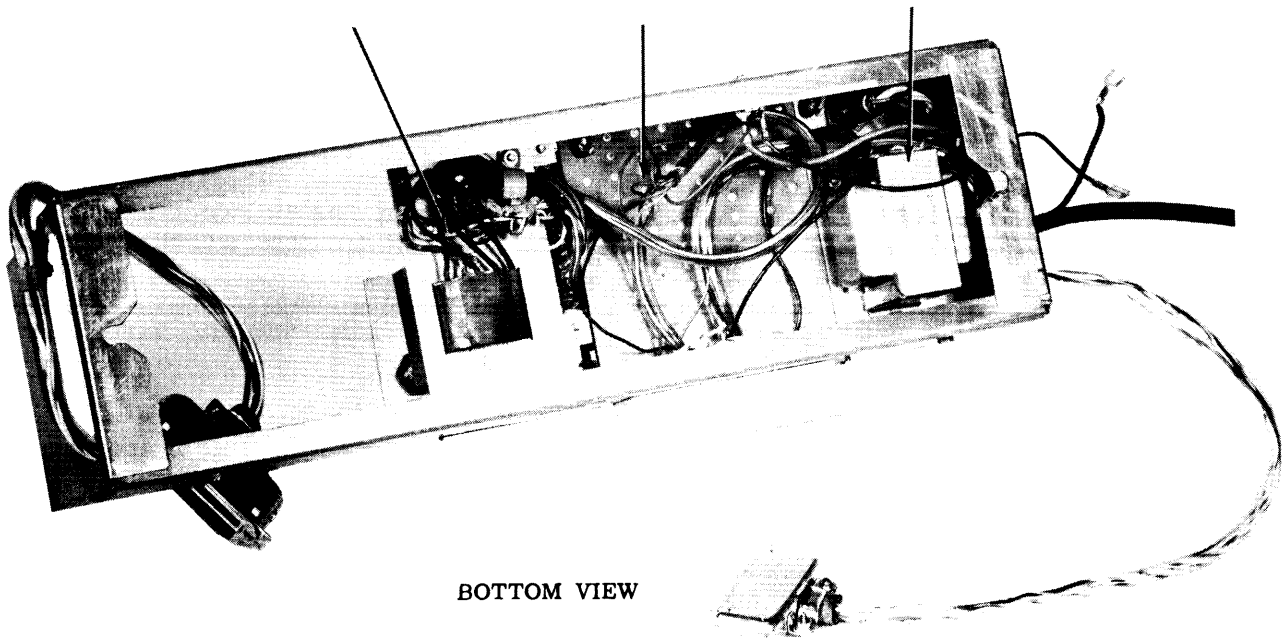

BOTTOM VIEW

Figure 1 - Typical Electrical Service Unit for 35 KSR Set

2.02 Some of the features that may be mounted on the unit are listed below:

- (a) A copylight transformer to supply power to the set's copylights.
- (b) A copylight receptacle.
- (c) A convenience receptacle.
- (d) Fuses for protection of the main power and other circuits.
- (e) A power and signal line terminal board.
- (f) A line-local relay to provide switching to either online or independent, local operation.
- (g) A main terminal board to provide a wiring field for connection of cable assemblies to the electrical service unit.
- (h) A motor control relay for remote control of the set's motor.
- (i) A main power on-off switch.
- (j) Ground strapping.
- (k) Cable assemblies, as required, for interconnection with other components of the set. The set's power cord may also be included.
- (l) A transistorized selector magnet driver assembly, to amplify the incoming line signal to 500 milliamperes for operation of the receiving circuit selector magnets. More than one assembly may be installed to accommodate the receiving circuits of a set. For example, in an ASR set, two assemblies may be used: one for the typing unit, the other for a reperforator.
- (m) A signal regenerator circuit to improve the output of the keyboard signal generator.
- (n) A tape feed-out relay to pulse a reperforator's tape feed-out magnet.
- (o) A reperforator control relay to blind a typing reperforator's selector magnets to line signals.
- (p) An automatic turn around traffic control circuit card and disabling switch.

(q) Control panel and cable assemblies, typically consisting of two panels and cabling. One panel may support the mode and other pushbutton controls, the other the end-of-line indicator lamp. In some electrical service units, only the cabling to the external controls panels is provided.

(r) A noncontention (NCT) relay to prevent a sending station's answer-back from operating when transmitting a WRU code.

(s) Automatic mode switch relays, or a manually operated rotary mode selector switch.

(t) A line jack connected across the external signal line for testing purposes.

(u) An auxiliary power supply.

(v) Character counter suppression components.

(w) A line-shunt relay, used in conjunction with a line test key and an auxiliary power supply, to allow local set operation.

2.03 The electrical service unit used with standard (dc) sets is wired to provide half duplex signal line operation. The unit may be wired (optional) to obtain full duplex operation, which permits receiving messages and transmitting them at the same time without interference between the two signals. This is accomplished by electrically separating the sending and receiving loops of the set by making wiring changes in the electrical service unit and connecting the loops to the appropriate duplex signal lines.

3. PRINCIPLES OF OPERATION

GENERAL

3.01 Since the major function of the electrical service unit is to provide support for circuit facilities, only general operating principles of selected components are presented below. Detailed operating principles will be found in the sections which discuss these components in relation to set operation.

3.02 The wiring diagram for the electrical service unit is incorporated into the schematics which appear in the appropriate section for each 35 set (ie, RO, KSR, and ASR).

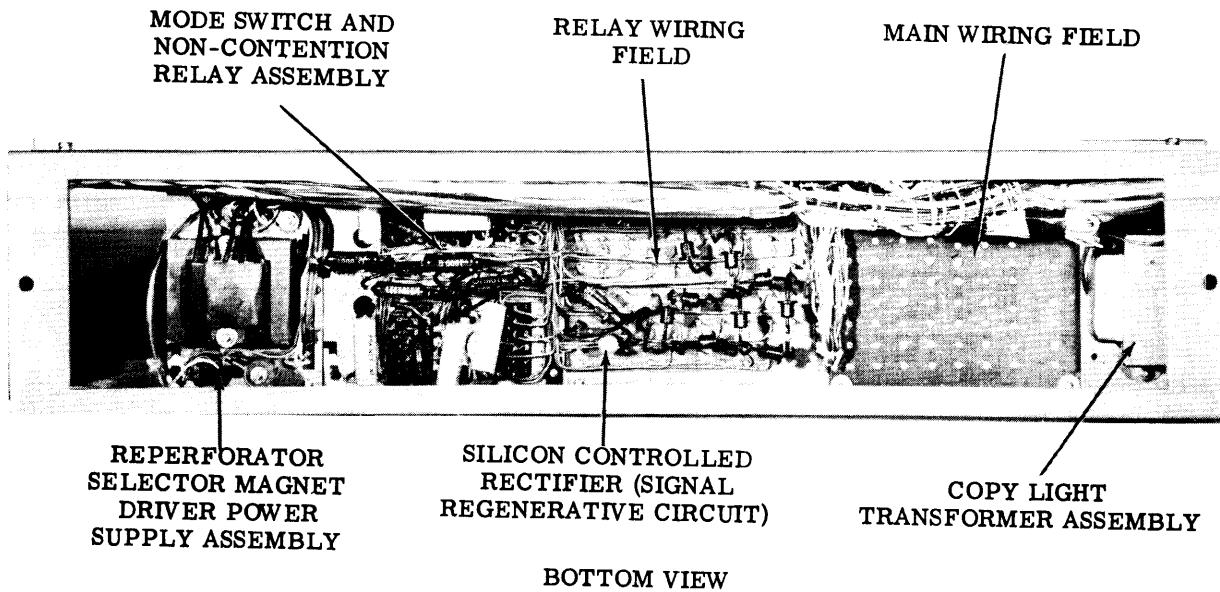
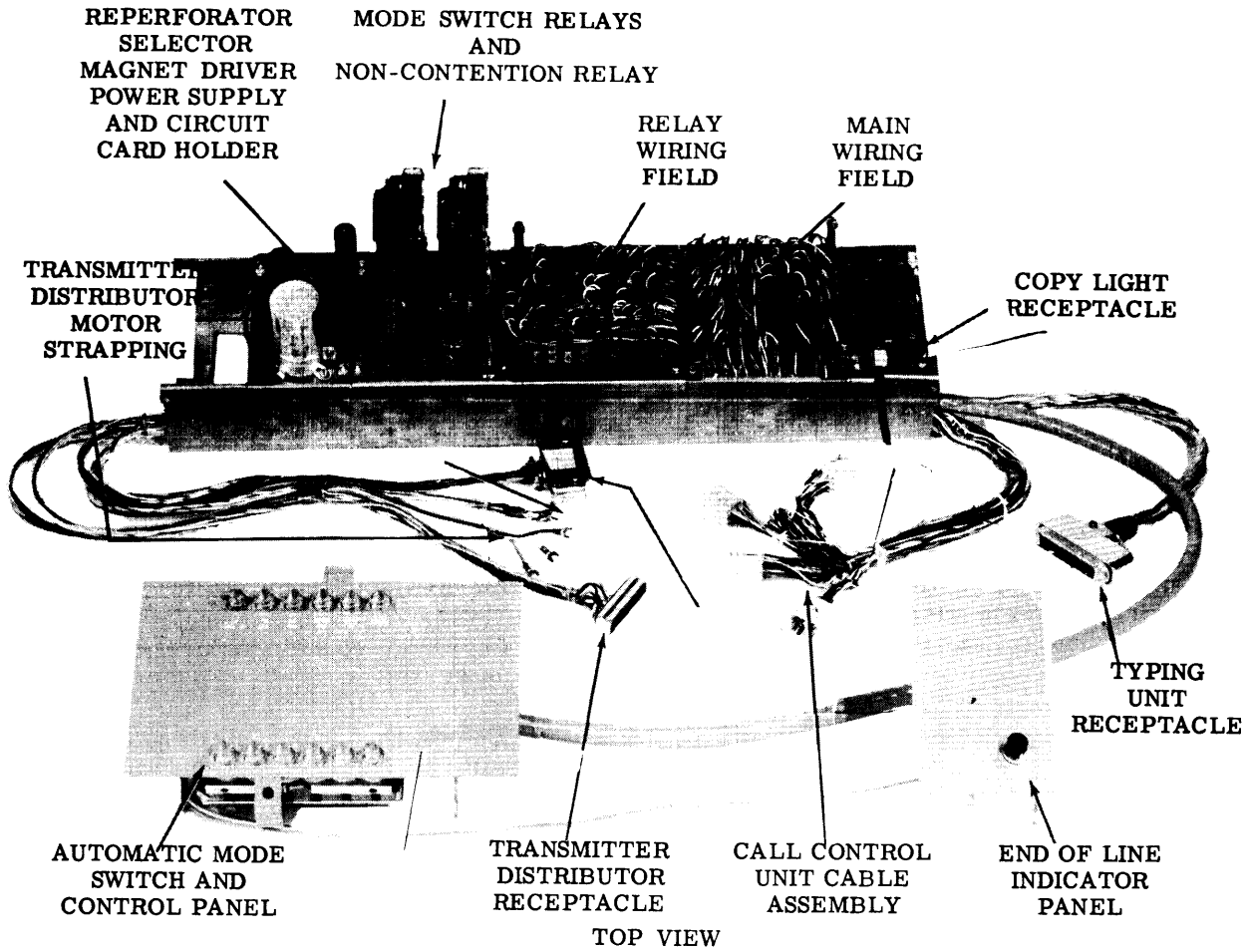

Figure 2 - Typical Electrical Service Unit for 35 ASR Set

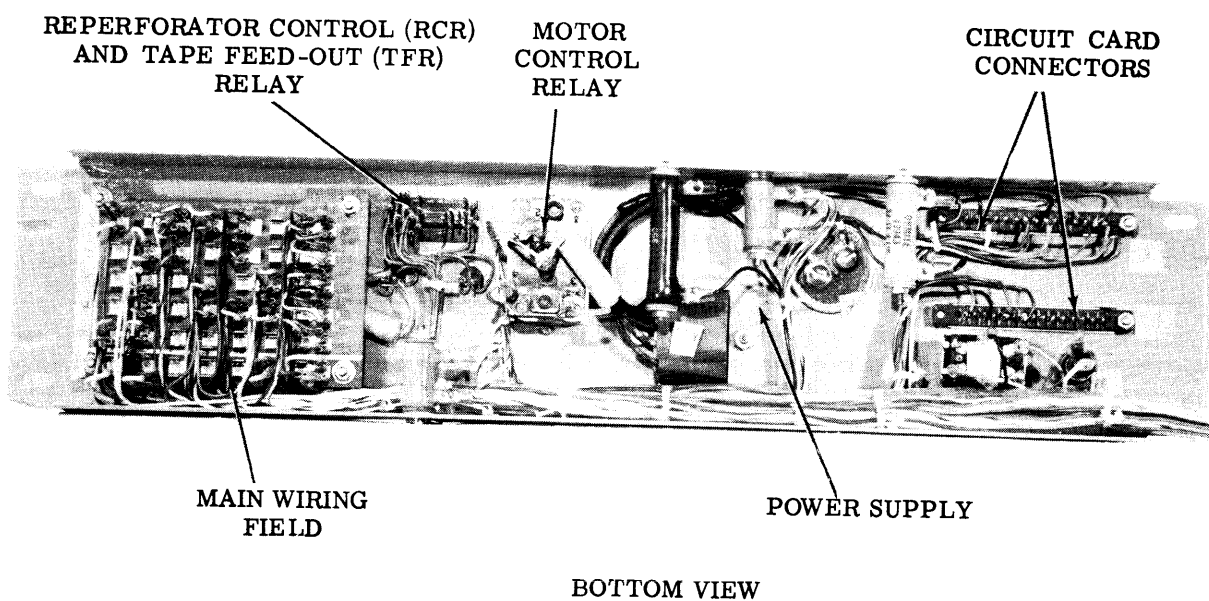
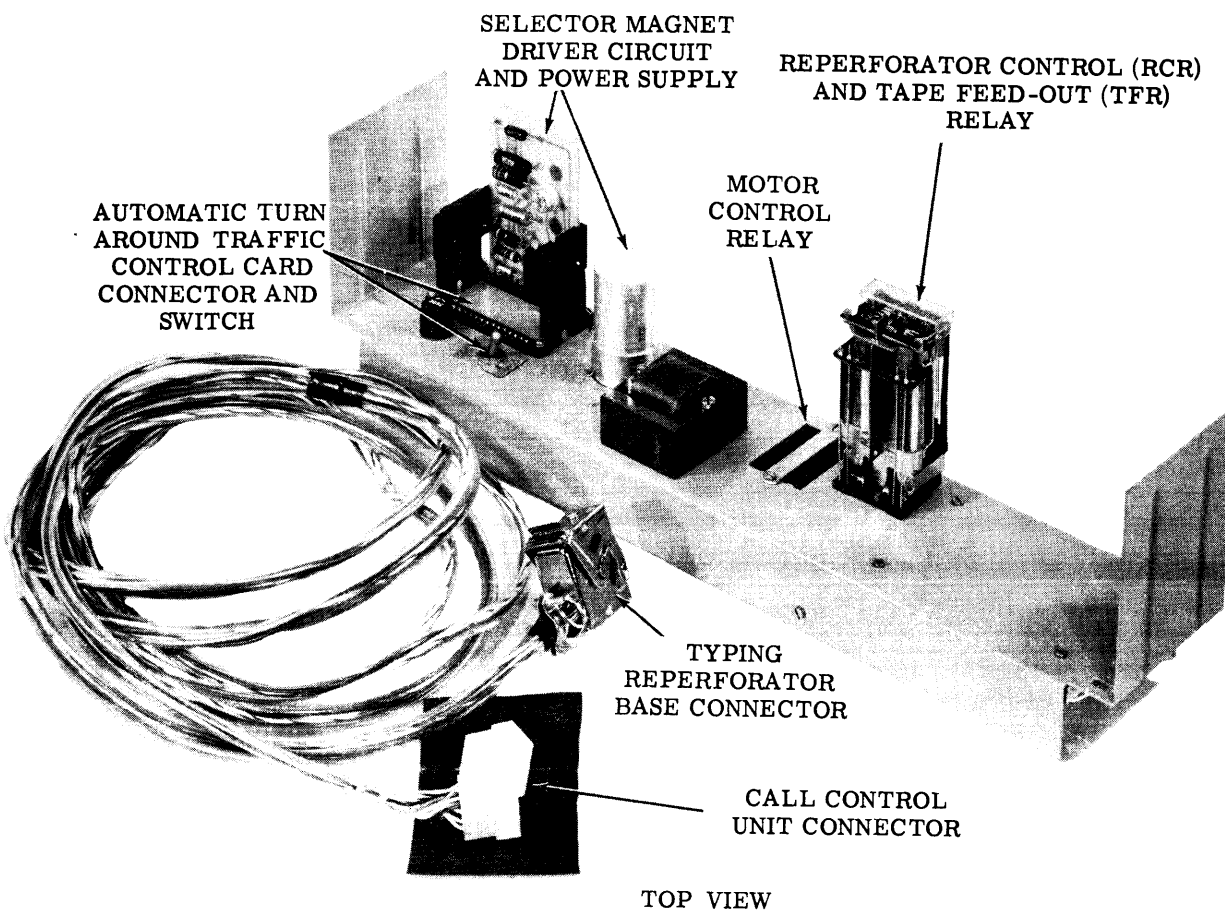

Figure 3 - Typical Electrical Service Unit for 35 ROTR Set

SELECTOR MAGNET DRIVER

3.03 The selector magnet driver assembly is a two stage transistorized amplifier capable of switching high output currents (0.500 ampere) at very closely controlled input current levels. The output of the driver is adjustable to 0.500 ampere output, but may change slightly due to normal supply voltage and component variations. Selector magnet driver assemblies are available which operate from either a 20 milliamperere or a 60 milliamperere line signal input.

CAUTION: DISCONNECT POWER TO SELECTOR MAGNET DRIVER ASSEMBLY - BEFORE REMOVING CIRCUIT CARD - TO AVOID DAMAGING TRANSISTORS.

LINE-LOCAL RELAY

3.04 The line-local relay is used to switch a set to either online or local operation. It is used in standard sets (dc) and is controlled by a rotary type power switch. With the switch in the ON position, the line-local relay energizes, placing the set's sending and receiving circuit in series with the signal line. The relay is energized via the selector magnet driver power supply (3.03).

3.05 Turning the power switch to the OFF position de-energizes the line-local relay. The external signal line to the set is shunted, but the selector magnets in the set's receiving circuits are held energized to prevent spurious characters from being typed or punched when the set is turned on and off.

3.06 With the power switch in the ONLINE position, the line-local relay is energized, and the signal generating and monitoring circuits of the set are connected into the signal line.

3.07 When the power switch is in the LOC (local) position, the set may be operated offline. The line-local relay de-energizes, shunting the external signal line to the set and connecting a local signal battery in series with the set's signal circuit.

ELECTRICAL MOTOR CONTROL

3.08 This feature permits a set's motor to be controlled remotely via the signal line. So equipped, the set may operate unattended. The sending station can turn the set on by send-

ing a break, or turn it off after the data has been transmitted by sending the EOT code.

MOTOR CONTROL RELAY

3.09 The motor control relay is energized by the closing of the OR/AN relay contacts in the ASR or KSR set (a local key in these sets is also provided to energize this relay). The motor control relay is held operated until the motor hold contact on the feed-out mechanism of the typing reperforator breaks at the end of the feed-out cycle.

REPERFORATOR CONTROL RELAY

3.10 The reperforator control relay (RCR) has five sets of contacts used for the following functions:

- (a) Selector magnet driver control.
- (b) RCR relay locking.
- (c) Tape-feed relay control.
- (d) Feed-out magnet control.
- (e) ROTR on lamp (in ASR) control.

The relay is energized by the closing of the R1 on contact in the ASR or KSR stunt box, or the ROTR ON key on the ASR control panel. The RCR relay is held energized by one of its own contacts, which is in series with the R1 off contact in the ASR or KSR stunt box.

3.11 The selector magnet driver control contact is normally closed, and shunts the signal line to the selector magnet driver, binding it to any signal. When the RCR relay is energized, the selector magnet driver will respond to the incoming signal.

AUTOMATIC TURN AROUND TRAFFIC CONTROL

3.12 The purpose of the automatic turn around traffic control (ATATC) is to blind the typing reperforator selector magnet driver to locally (ASR or KSR set) generated traffic, while allowing incoming traffic through. An all-traffic switch is provided to disable the ATATC.

TAPE FEED-OUT CONTROL RELAY

3.13 The tape feed-out control relay (TFR) is controlled by the reperforator control relay (RCR). A make contact on the TFR relay and a break contact on the RCR relay are wired in series with the tape feed-out magnet on the typing reperforator. When both relays are operated, the RCR contact is opened and the TFR contact is closed. When the RCR relay releases, the RCR contact closes and the TFR contact remains closed for 65 milliseconds (slow release). This allows the tape feed-out magnet to energize, initiating tape feed-out.

LINE-SHUNT RELAY

3.14 This feature permits local operation of a set in addition to online operation. When the LINE-TEST key is placed in the TEST position, the line-shunt relay de-energizes, shunting the external signal line and switching in an auxiliary power supply in series with the set's signal circuit.

CHARACTER COUNTER SUPPRESSION

3.15 Suppression of the character counter mechanism (ASR sets) is desirable from a standpoint of operating flexibility. Suppressing the character counter allows the operator to prepare tape in the tape mode, switch to keyboard mode and use the keyboard, and return to the tape mode without disturbing the character count.

MODE SWITCHING COMPONENTS

A. Automatic

3.16 Automatic mode switching components for ASR sets provide the following operating features:

- (a) The ability to prepare tape while transmitting or receiving traffic.
- (b) The ability to transmit or receive traffic using codes foreign to the set.
- (c) The ability to receive traffic on tape and by page printer simultaneously.
- (d) The ability to revert to a common mode of operation when clearing the set.

3.17 To provide these features, mode switching relays, which operate in conjunction with a pushbutton control panel, allow the operator to automatically select the set's operating mode. One of five modes may be selected: keyboard (K), keyboard-tape (KT), tape (T), tape-tape send (TTS), or tape-tape receive (TTR).

B. Manual

3.18 Manual mode switching components for ASR sets provide the (a), (b), and (c) operating features listed in Paragraph 3.16. A conveniently located rotary selector switch allows the operator to manually select the set's operating mode. One of five operating modes may be selected: K, KT, T, TTS, or TTR (see 3.17).

35 CALL CONTROL UNIT

GENERAL DESCRIPTION AND PRINCIPLES OF OPERATION

CONTENTS	PAGE	CONTENTS	PAGE
1. GENERAL DESCRIPTION	1	4. CALL CONTROL UNIT - 35 AUTOMATIC SEND-RECEIVE (ASR) SET	14
2. CALL CONTROL UNIT - 35 RECEIVE-ONLY (RO) SET	3	DESCRIPTION	14
DESCRIPTION	3	PRINCIPLES OF OPERATION	14
PRINCIPLES OF OPERATION	4	A. Originating a Call	14
A. Originating a Call	4	B. Speaker Amplifier System	14
B. Answering a Call - Manual and Automatic	4	C. Dial Mechanisms	14
C. Signal Generation	5	D. Answering a Call - Manual and Automatic	14
D. Receive Circuit	5	E. Automatic Mode Switching	14
E. Disconnecting a Call	6	F. Send Circuit - Signal Regenerator	16
F. Out of Service Switch	6	G. Keyboard Send Circuits	17
G. Low Paper Alarm	6	H. Transmitter Distributor Con- trol and Send Circuits	17
H. Make Busy Circuit	7	I. Receive Circuits	18
I. Form Feed-Out	7	J. Auxiliary Local Circuits	19
J. Test Mode	7	K. Disconnecting a Call	19
K. Auxiliary ROTR	7	L. Local Operation	19
3. CALL CONTROL UNIT - 35 KEYBOARD SEND-RECEIVE (KSR) SET	7	M. Out of Service Switch	19
DESCRIPTION	7	N. Low Paper Alarm	19
PRINCIPLES OF OPERATION	9	O. Make Busy Circuit	19
A. Originating a Call	9	P. Form Feed-Out	19
B. Speaker Amplifier System	9	Q. Test Mode	19
C. Dial Mechanism	9	R. Auxiliary ROTR	19
D. Answering a Call - Manual and Automatic	12	1. GENERAL DESCRIPTION	
E. Send Circuit - Signal Regenerator	13	1.01 This section is reissued to convert it from a preliminary publication to a stand- ard publication.	
F. Receive Circuit	13	1.02 The 35 Call Control Unit (LCCU) is an electrical control device which, when used in conjunction with a Data Set, provides for both automatic and manual control of 35 page printing and tape equipment over standard tele- phone networks.	
G. Disconnecting a Call	13	1.03 The call control units, as discussed in this section, are for use in the Bell Sys- tem Wide Area Data Service (WADS) telephone network. Two different call control units are	
H. Local Mode	13		
I. Out of Service Switch	13		
J. Low Paper Alarm	13		
K. Make Busy Circuit	13		
L. Form Feed-Out	13		
M. Test Mode	14		
N. Auxiliary ROTR	14		

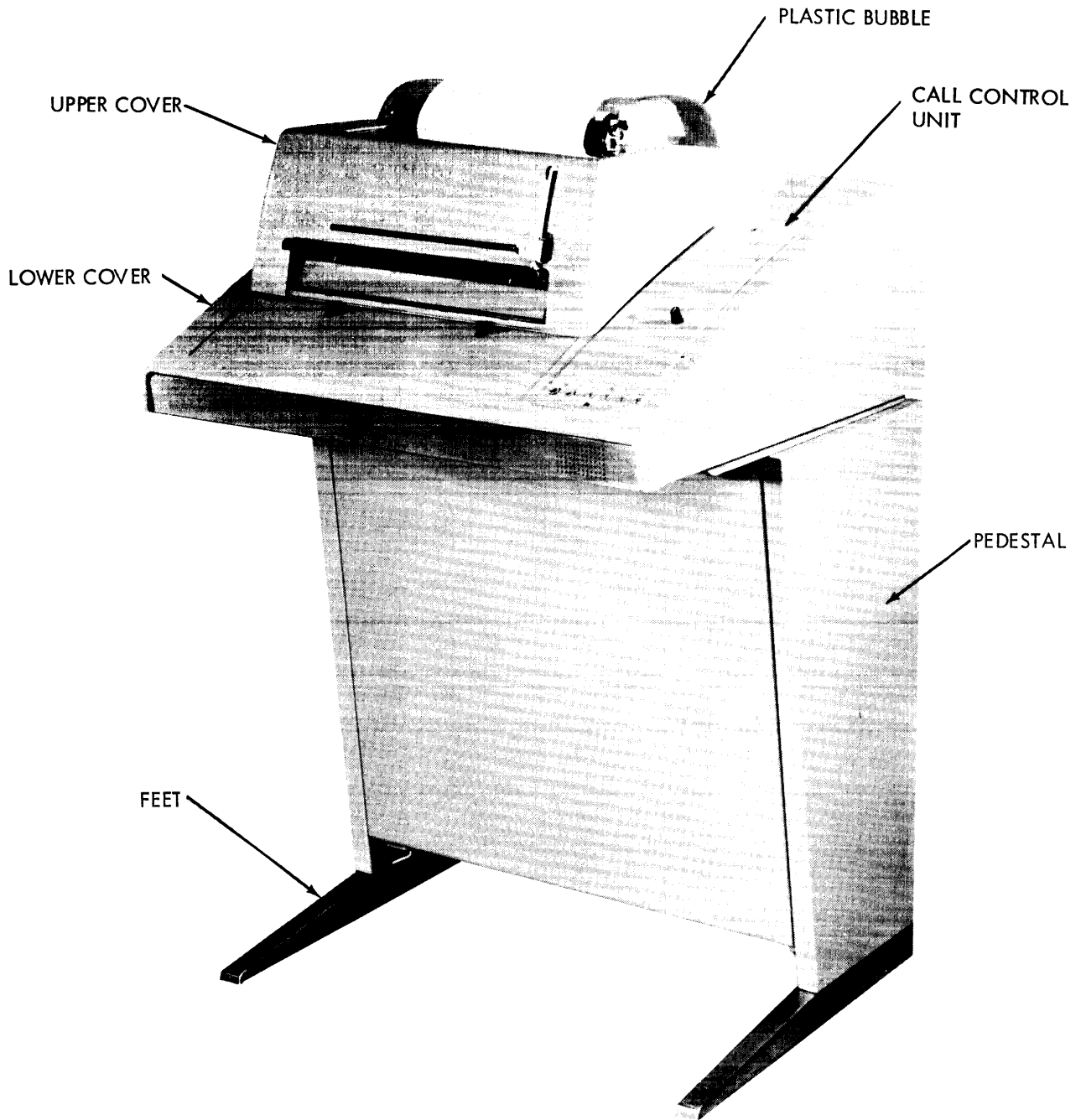

Figure 1 - Receive Only Set with Call Control Unit

utilized in this system: an LCCU 300 (Bell 35A), and an LCCU 301 (Bell 35B). The units are essentially identical in relation to their basic function (i. e., control of page printing and tape equipment in conjunction with a Data Set), differing mainly in the number of features and/or functions controlled by the units. As part of the WADS system, the call control units are used in the following sets:

- (a) Call Control Unit LCCU 301 (Bell 35B) is used in the 35 Receiving-Only (RO) Set.
- (b) Call Control Unit LCCU 300 (Bell 35A) is used in both the 35 Keyboard Send-Receive (KSR) and Automatic Send-Receive (ASR) Sets.

1.04 Complete operation of the call control units requires connections with a Data Set (see appropriate section), and with an electrical service unit (LESU) (see the appropriate section).

- (a) Data Set: The Data Set's function is to provide the modulating and demodulating apparatus necessary for transmission of telegraph signals over telephone circuits. It also provides the call-connecting devices which condition the sending and receiving station(s) for reception and/or transmission of a message.
- (b) Electrical Service Unit: The electrical service unit, used in conjunction with the call control unit, provides relay, circuit, and wiring facilities necessary to operate the various components, lights, and controls which are associated with a given set. The facilities provided by the electrical service unit will vary, depending on the number and complexity of functions performed by the set.

1.05 In the paragraphs that follow, the complete description and principles of operation of the call control units will be presented in the following order:

- (a) Paragraph 2 will discuss the LCCU 301 (Bell 35B) as used in 35 RO Sets.
- (b) Paragraph 3 will discuss the LCCU 300 (Bell 35A) as used in the 35 KSR Sets.
- (c) Paragraph 4 will discuss the LCCU 300 (Bell 35A) as used in the 35 ASR Sets.

Operating principles of the associated electrical service units will be incorporated in the above

discussions, as necessary. General description of the electrical service units, however, will be covered in another section. Discussion of the Data Set will be limited to a description of the call connection, input, and output circuits, but only in sufficient detail to indicate how they condition - or are conditioned by - the call control unit.

1.06 Wiring diagrams referred to in paragraphs 2, 3, and 4 may be found in the RO, KSR, or ASR section with which the Call Control Unit is associated.

2. CALL CONTROL UNIT - 35 RECEIVE-ONLY (RO) SET

DESCRIPTION (See Figure 1)

2.01 The Call Control Unit is located to the right of the page printer, mounted on the cabinet pan assembly. The LCCU extends from the front to the rear of the set, and is higher at the rear than at the front. At the front of the unit is a row of six illuminating push buttons designated (from left to right):

- (1) ORIG (Originate)
- (2) CLR (Clear)
- (3) ANS (Answer)
- (4) TST (Test)
- (5) LCL (Local)
- (6) BUZ RLS (Buzzer Release)

The first three (ORIG, CLR, and ANS) are momentary-type push buttons, while the last three are locking-type. An OUT OF SERVICE switch and lamp are located behind and above the six illuminating push buttons.

2.02 Other features of the call control unit include:

- (a) A ringer mechanism to signal an incoming call.
- (b) A transistorized selector magnet driver assembly.
- (c) A power supply which provides the necessary operating potentials and current for the various controls and circuits.
- (d) Fuses, for circuit protection, and a 117 volt convenience outlet.

- (e) A cable termination area, at the rear, which provides eight female receptacles for interconnection of components.
- (f) An AC power cord for connection of the set to the power line.

A BK (Break) switch, HERE IS switch, and terminals for connection of a dial are also provided. These facilities are normally used for maintenance purposes, and are not readily accessible when the set is in an operating condition, with its cover on.

2.03 In addition to the above, the call control unit can be adapted for the following features:

- (a) A Make Busy circuit.
- (b) Connection of an auxiliary receive-only typing reperforator (ROTR).
- (c) Alternate mode functions.

PRINCIPLES OF OPERATION - See WD6040 (RO)

A. Originating a Call

- 2.04 **General:** Normally, only maintenance personnel will have reason to originate a call. Screw connections are provided to connect a temporary dialer for station calling purposes.
- 2.05 **Calling:** A call is originated by depressing the ORIG push button. This connects the station to the line, and lights the ORIG lamp. The lamp will remain lit until the originate mode is terminated. In cases where the Data Set relay will not lock up to connect the station to the line, the ORIG push button (a non-locking type) must be held depressed. If the line is busy, or a wrong number or no connection signal is received, depressing the CLR push button will disconnect the set from the line so the call can be re-made.
- 2.06 **Hand Held Receiver:** The receiver is used for monitoring the call progress. It is connected to the line via the buffer amplifier in the Data Set limiter. The line connection permits monitoring of supervisory signals when originating a call or when operating an out of service switch in the restore position.
- 2.07 **Rotary Dial:** For pulse dialing application, a rotary dialer can be temporarily

connected to the call control unit for maintenance purposes. The manual rotary dial is equipped with a normally closed pulsing contact, and a normally opened off-normal contact. The pulsing contact is inserted into the telephone line when the station originates a call. When answering, a short circuit is applied across the pulsing contact. The off-normal contact is placed across the amplifier output, and silences the receiver whenever the dialing disk is moved.

B. Answering a Call - Manual and Automatic

Manual Answering

2.08 To answer a call manually, the ANS push button is momentarily depressed. This connects the station to the line, and lights the ANS lamp. The lamp remains lit until the answer mode is terminated. Manual answering is necessary only when the automatic answer-back circuit is disabled. The automatic answer-back circuit is disabled by the tabulating contacts, form feed contacts, low paper contacts, low tape contacts (auxiliary ROTR), Data Set relay contacts (when in local mode), and the out of service switch.

Automatic Answer Back

2.09 **General:** The answer-back message is a fixed series of characters used to identify a station. The mechanism is mounted behind the page printer, and consists of a commutation disk and brush type of distributor, and a coded drum with sensing contacts to determine the message. The drum has 21 positions for characters. This can be reduced to three sections of 7 positions by removing tines in the drum. The output can be blinded on a given character position by one of the sensing contacts if the associated tine on the drum is removed. The drum is coded to send the required message by removal of the appropriate tines on the drum. Any fixed message (from 1 to 20 characters in length) can be sent out by the answer back mechanism.

NOTE: The first character position must always be blinded for timing reasons.

2.10 **Circuit Description:** The answer-back drum is allowed to rotate by pulsing the armature coil from either the Data Set, WRU contacts in the page printer stunt box, or the HERE IS key. When the Data Set at an answering station makes a complete connection to the sending station, it puts ground on the answer-back coil circuit and allows the coil to energize and trip the answer back. When the drum starts ro-

tating, the answer back off-normal contacts close and allow the non-repeat relay (ABR) to energize. The break contacts on the ABR relay open the pulsing circuit to the answer-back coil (ABC), and permit only a single operation of the mechanism. The make contacts on the ABR relay provide the holding circuit for the ABR relay until the call has been completed or the circuit interrupted.

2.11 During a call, the answer-back mechanism can be tripped manually via the HERE IS switch, or by stunt box code recognition (WRU). The make contacts provide ground to operate the answer-back clutch trip magnet.

C. Signal Generation

2.12 The receive-only (RO) set can send by operating the answer-back mechanism or break (BK) key. The answer-back distributor is connected to the Data Set. The BR key is connected to the Data Set on separate leads. The BK key sends a spacing signal which the Data Set limits to about 120 milliseconds. Thus, the local printer runs open for about 100 milliseconds until the break detector operates, lighting the break release lamp.

D. Receive Circuit

General

2.13 The Data Set supplies a 20 milliampere DC signal to the selector magnet driver associated with the page printer. The selector magnet driver amplifies the signal to 500 milliamperes to operate the selector on the page printer. The output of the selector magnet driver is automatically maintained at 500 milliamperes. Provision is made for insertion of an auxiliary ROTR selector magnet driver in series with the page printer selector magnet driver. The ROTR can be equipped with turn around traffic control to blind the ROTR selector magnet driver to locally generated traffic.

Selector Magnet Driver

2.14 General: The selector magnet driver is a two stage transistorized amplifier capable of switching high output currents (0.500 ampere) at very closely controlled input current levels. The output of the driver is automatically regulated, and is essentially independent of normal variations in power supply voltage and of selector magnet and current limiting resistance values.

NOTE: Not all sets will be equipped with a constant current selector magnet driver. In some early units, a non-regulated driver circuit card will be supplied instead. For a discussion of this circuit, refer to Par. 4.35 through 4.39 of this section.

2.15 Open Line: When the line circuit is open (SPACING), transistor Q1 will be turned on by the regulated current flowing through R1 into its base. This current, which is controlled by R1, will be set near the desired switching level. With Q1 conducting, Q2 will be cut off, since the potential at the base of Q2 will be more positive than at the emitter. In this condition, only small leakage currents will flow in the collector circuit.

2.16 Space - To - Mark Transition: As the SPACE-TO-MARK transition begins, the negative bias current flowing in the base of Q1 is diverted to the line circuit. As the line current rises toward the MARKING current value, it extracts base current from Q1. When the line current approaches the total current supplied to the base of Q1 to within 0.001 ampere, which is about one half the nominal mark current value, Q1 begins to turn OFF. Q2 will then begin to receive forward bias current from R8 and begin to turn ON. The base current will then be amplified by Q2, and a current which is a multiple of the base current will appear in the emitter circuit. This increase in emitter current results in an increase in the negative potential measured across R3. The increase in the negative potential at the emitter of Q1 causes it to go further into cut-off. The feedback process continues until the current in the selector magnet reaches a value which is determined by the zener reference voltage, clamp diode CR4, and the emitter resistance of Q2 (the emitter resistance of Q2 is adjusted by R4 to compensate for component variations). As the line current completes the transition to the final marking current value, the base of Q1 becomes positively biased. The positive bias current will be approximately one-half the total marking line current. The positive potential at the base of Q1 is clamped to approximately 0.6 volts by the input protecting varistor, CR5.

2.17 Mark-To-Space Transition: The line current, in changing from MARK-TO-SPACE, will finally reach the point where R1 will begin to supply some forward current to the base of Q1. The line current level at which this occurs will be a little more negative than the point at which the circuit switched from space to mark, due to the common emitter resistor volt-

age feedback. As Q1 begins to turn ON, the current through R8 will be diverted from the base of Q2 causing it to begin to turn OFF. As Q2 turns OFF, the voltage across R4 will begin to go positive, causing Q1 to be further turned ON. This effect gives regeneration to the MARK-TO-SPACE transition.

2.18 Mark - To - Space Switching Transient:

When Q2 is turned off during the MARK-TO-SPACE transition, a negative voltage transient is developed at its collector. This transient is due to dissipation of the energy stored in the magnetic field of the driven magnet when energized by 0.500 ampere. If the high voltage developed at the collector of Q2 is not limited, it would continue to rise until the collector-to-emitter breakdown voltage is exceeded. It has been found that repeated breakdown of this kind causes deterioration of the transistor, and finally, a collector-to-emitter short circuit. Therefore, it is necessary to provide a transient suppressing network at the collector of Q2. The transient suppression network presently in use is a compromise which affords a minimum peak voltage combined with a magnet release time to provide for adequate printer margins. The network consists of C1 in parallel with R9. CR3 isolates the network from voltages more positive than negative battery potential.

E. Disconnecting a Call

2.19 A call is normally terminated by the EOT code combination which provides fast disconnect without introducing hit characters. This is accomplished by the Data Set, in response to EOT contact closures in the stunt boxes of both the sending and receiving sets.

2.20 A call connection can also be cleared manually by momentarily depressing the CLR push button. This triggers the clearing sequence in the Data Set, and lights the CLR lamp. The CLR lamp will remain lit for the duration of the call. During the first 100 milliseconds of the clearing sequence, the BK lamp will also light.

F. Out-of-Service Switch

2.21 The out-of-service switch prevents the automatic answering of incoming calls. In its NORMAL position, it has no effect or function (arrow upright); in the OUT-OF-SERVICE position (rotated counterclockwise and detented) it sets the following conditions.

- (a) A contact is closed that applies power to the out-of-service light.

- (b) A contact is closed and shorts the ringer coils. This makes the ringer inoperative. As an option the contact can be located to shunt both the ringer and series capacitor (i.e., the telephone line). This makes the station appear off hook or busy to the central office.

- (c) A contact is opened that breaks the automatic answer circuit to the answer relay. This prevents the relay from operating in response to the ring up relay and thus the set will not answer.

2.22 For stations that are not in terminal hunting groups, the operator may return the set to service by turning the out-of-service switch to its NORMAL position. For terminal hunting stations, however, the operator must turn the switch to the RESTORE position and hold it until a dial tone is heard. In this position:

- (a) A contact is closed that shorts the tip to ring (off-hook condition). This condition is detected by the central office which then releases the set from lock-out and applies the dial tone.

- (b) A contact closes which completes a path from the ORIG lamp to ground.

G. Low Paper Alarm

2.23 A low paper alarm is provided in the page printer and the auxiliary ROTR, either of which can independently operate the low paper buzzer. The set provides low paper alarm circuits in friction feed sets and, in addition, a paper-out disconnect feature and a form out and tabulating system. The out-of-service switch may be used to facilitate paper insertion.

2.24 When a low paper condition occurs, make contacts in the low paper switch provide ground to the low paper buzzer permitting it to operate. Depressing the BUZ RLS key (locking) in the call control unit silences the buzzer and provides an operate path to the BUZ RLS lamp. Attempting to release the key without replenishing the paper supply will cause the buzzer to operate. When the paper has been replenished, the set is returned to normal by releasing the BUZ RLS key. When used with more complex circuits, the key can be made non-locking.

2.25 Break contacts on the low paper switch disable the automatic answer-back circuit placing the set in a don't answer condition. A low tape condition also prevents an automatic

answer. The operator can override the don't answer condition by manually answering. If the low paper alarm occurs during a call, the operator has the option of completing the call before changing the paper or interrupting the call. To interrupt the call, the operator stops transmission by depressing the BREAK key followed by depressing the BK RLS key to notify the distant station of the problem. The connection is cleared by simultaneously operating the control and EOT keys. Turning the out-of-service switch to the detent position insures that the set will not automatically answer a call while paper is being replenished.

2.26 To restore the set to service, after paper has been inserted, depress the CLR button. This enables the low paper buzzer and the answer-back mechanism. Return the OUT-OF-SERVICE switch to its normal position. (For sets in terminal hunting groups, turn the switch to its RESTORE position and hold it there. When a dial tone is heard, release the switch.) The set is now in a normal idle operating position.

H. Make Busy Circuit

2.27 A make busy option is provided for specific applications. Separate low paper make contacts connect the make busy lead from the TIP side of the telephone line to the Data Set. The option is obtained by a wiring change in the electrical service unit wiring field. The contacts are adjusted so that as the paper runs low the alarms are activated before the make busy circuit takes effect.

I. Form Feed-Out

2.28 In the sprocket feed printers paper out make contacts provide a disconnect feature. These contacts, when paper has been exhausted, perform the same functions as the CLR key. The paper out contacts are used in conjunction with the low paper contacts therefore, no calls will be accepted following the disconnect until the paper supply has been replenished.

2.29 In sprocket feed printers the form feed mechanism is tripped mechanically from stunt box recognition of the FORM code and in addition whenever the Data Set disconnects unless the paper is between forms. The Data Set energizes the form out solenoid during the disconnect sequence when the form out off-normal contacts in the printer are closed.

2.30 The sprocket feed printer is also equipped with horizontal and vertical tabbing

mechanisms which are controlled by code recognition in the stunt box. During the tabbing or form feed operation the associated stunt box contacts hold the motor control relay (MCR) energized and open the automatic answer back circuit. This allows the tabbing or form out operation to be completed before any subsequent call is answered.

J. Test Mode

2.31 If the TST key is operated while the set is connected to a test center, the message sent by the test center will be recorded on the page printer and turned around and sent back for analysis. This is accomplished by connecting the teletypewriter to the Data Set through a set of transfer contacts and a break contact to ground. This type of operation can be terminated by momentarily operating any of the non-locking keys which will then release the TST locking key.

K. Auxillary ROTR

2.32 A set can be equipped with a self-contained typing reperforator which operates on the same signal as the page printer. The ROTR features automatic non-interfering tape feed out, turn-around-traffic-control, selective operation controlled by stunt box code recognition, all traffic switch, motor control, and low tape alarm contacts and lamps. Detailed description of the ROTR is covered in a separate section.

3. CALL CONTROL UNIT - 35 KEYBOARD SEND-RECEIVE (KSR) SET

DESCRIPTION (See Figure 2)

3.01 The Call Control Unit for the KSR Set is located to the right of the page printer and is mounted on the cabinet pan assembly. It is almost physically identical to the call control unit used in the 35 receive-only (RO) set (refer to Par. 2.01 and 2.02), but is electrically more complex.

3.02 The most obvious physical feature which distinguishes the LCCU 300 (Bell 35A) from the LCCU 301 (Bell 35B), is the presence of a rotary or touch-tone dialing mechanism located immediately behind the front row of illuminating push buttons.

3.03 The call control unit includes the following features:

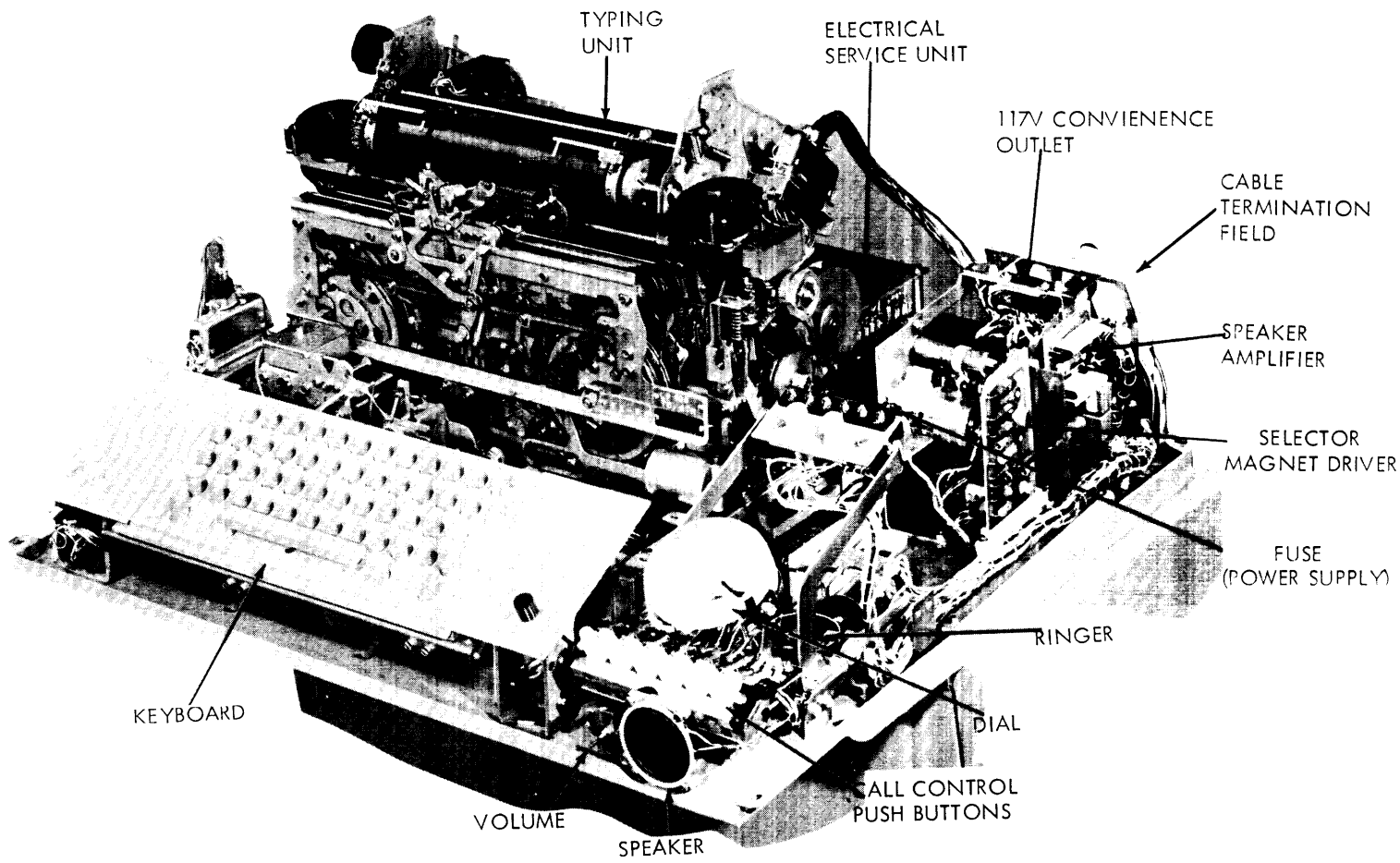

Figure 2. Keyboard Send Receive Set with Call Control Unit

- (a) A ringer mechanism to signal an incoming call.
- (b) A transistorized selector magnet driver assembly.
- (c) A transistorized speaker - amplifier assembly.
- (d) A volume control to set the speaker level.
- (e) A power supply which provides the necessary operating potentials and current for the various controls and circuits.
- (f) Fuses for circuit protection, and a 117 volt convenience outlet.
- (g) A cable termination area, at the rear, which provides eight female receptacles for interconnection of components.
- (h) An AC power cord for connection of the set to the power line.
- (i) A combined break (BK) lamp and reset push button (white, upper), REST lamp (amber), OUT-OF-SERVICE lamp (white, lower), and out of service rotary switch. This group of controls is located behind the dial mechanism. The lamps which separate the controls are for future system use.

3.04 In addition to the above, the call control unit can be adapted for the following features:

- (a) Automatic pulsing or tone card dial mechanism.
- (b) Make busy circuit.
- (c) Call progress lamps.
- (d) Hand held receiver.
- (e) Connection of an Auxiliary Receive-Only Typing Reperforator (ROTR).

PRINCIPLES OF OPERATION - See WD6020 (KSR)

A. Originating a Call

3.05 To originate a call, the ORIG nonlocking key is momentarily operated. This connects the station to the line and lights the ORIG lamp. The lamp remains lit until the originate mode is terminated. If the line is busy, or a

wrong number or no connection signal is received, depressing the CLR push button will disconnect the set from the line so the call can be re-made.

B. Speaker Amplifier System

3.06 The loudspeaker amplifier is powered only after the ORIG key is operated, and is operated, and is quieted when the station connects. It has two inputs, one from the line via the buffer amplifier in the Data Set limiter and the other from the touch-tone dial (TTD). Three outputs are provided: (1) into the loudspeaker or optional hand held receiver, (2) into the line through the sending amplifier in the Data Set, and (3) an auxiliary output into the Data Set. The line to loudspeaker connections permits monitoring of supervisory signals when originating a call. The touch-tone dial-to-line and touch-tone dial-to-loudspeaker connection provides for amplification of the outgoing multifrequency dialing signals and for monitoring them during outpulsing. The line-to-second output connection is provided for the dial tone detector (when furnished). The various connections mentioned are established by switching in the Data Set, and by the common switch in the touch tone dial.

3.07 The speaker amplifier is a conventional direct coupled 2-transistor audio amplifier. The input signals from the line are fed through the receiving buffer amplifier in the Data Set into the primary winding of the input transformer. The primary winding continuously carries approximately 4 MA quiescent current from the receiving buffer amplifier. The other input, from the TTD, is fed directly into Q1 through C5A. Both inputs are DC isolated from the amplifier stages.

3.08 Two outputs are taken from transistor Q2A, one from the collector circuit and the other from the emitter.

(1) The collector output is fed through a step down output transformer (T2) into the loudspeaker (or receiver). Potentiometer RS is used to set proper volume for varying loop loss and ambient noise level. The TTD signals are independent of loop loss.

(2) The emitter output splits into two signal lines: one for injecting the multifrequency (MF) dial tones into the Data Set sending amplifier, and the other for feeding the dial tone detection circuit (when provided). The signal level from the emitter output is essentially independent from the setting of potentiometer RS.

3.09 By-passed R6A is a supply voltage dropping resistor. Diode CR1A is provided to block a sneak path (in the answer mode) from ground through the ANS and ORIG lamps. Without CR1A, the ORIG lamp would be dimly lit and the amplifier would not be silent, when the station is in the answer mode. The amplifier operates only in the originate mode until the station connects. In any mode other than originate, the ground is disconnected. When the station connects, the amplifier input is short circuited in Data Set.

C. Dial Mechanisms

Rotary Pulsing Dial

3.10 For pulse dialing application, a pulsing contact of the rotary dial is inserted in the telephone line. The manual rotary dial is equipped with a normally closed pulsing contact and a normally opened off-normal contact. The pulsing contact is inserted into the telephone line when the station originates a call. When answering, a short circuit is applied across the pulsing contact. The off-normal contact is placed across the output of the amplifier, and silences the loudspeaker (and receiver) whenever the dialing disk is moved.

Pulsing Card Dial

3.11 To use the card dialer, the ORIG key is operated. After dial tone has been received, a card with the telephone number punched is fully inserted in the slot. This operation winds a spring motor, which later pushes the card out of the slot as the dialing proceeds.

3.12 The dialer is started by momentarily depressing the START bar. This operates the DIAL START contact, and establishes a path from the ring side of the telephone line through point 5 on the dialer, the released pulsing relay contacts K (P), pulsing relay K (P), released HOME and DIAL START contacts, operated DIAL START contacts, and point 2 on the dialer to the tip side of the telephone line. The current from the central office battery operates the pulsing relay K (P), which transfers the ring to tip path to the Matrix. This path is closed or opened according to the code punched in the card. The dial pulse is transmitted as the sensing springs sense the holes in the card.

3.13 Sending of the dial pulse means interruption of the current in the telephone line. This releases the K (P) relay. Movement of the K (P) relay armature rotates the scanning drum

by 1/16 revolution so that the next digit pulse can be sensed and transmitted as the K (P) relay re-operates. After two pulses have been transmitted, the HOME contacts operate and remain operated until the end of the scanning drum revolution. This establishes a direct operating path for the K (P) relay so that, when the station is returned on-hook in the middle of the digit, the digit pulsing can be completed and the drum will be returned to its normal (HOME) position.

3.14 In this manner, the drum completes the revolution in 16 steps. 10 of the steps are required to send the digit, and 6 to provide the interdigital time. At the completion of revolutions, an escapement is tripped which permits the next row of holes on the card to be placed in position for sensing.

3.15 This sequence is repeated at each row as the card advances out of the dial. If no STOP code is punched in the card, the dialer will keep advancing the card (even if no number code is punched) until the card is released. If a STOP code is sensed, the DIAL STOP contacts operate. With the HOME contacts released, a transmission path is established from the telephone line to the Data Set input as follows: RING - point 5, DIAL STOP contact operated, HOME contacts released, point 1, hybrid coil in the Data Set, TIP. The Data Set can then complete the connection.

3.16 When the station is connected, the card can be released by operating the RELEASE bar. No attempt should be made to release the card by operating the START bar, as this will trigger the dialing mechanism and the following short circuit will be placed across the output of the Data Set: point 1, HOME and DIAL START contacts released, DIAL START contacts operated, point 2. And, after the first two pulses on each revolution: point 1, HOME contacts operated, point 6. This shunt will prevent the station from receiving or sending until the card is disengaged. If this condition persists, the Data Set will disconnect.

Touch-Tone Dial

3.17 For multifrequency dialing (MF) application, the dialing frequencies generated by the touch-tone dial are fed through the loudspeaker amplifier and into the telephone line via the sending amplifier in the Data Set. The touch-tone dial can be equipped with the card dialer. To use it, the ORIG key is operated, creating the off-hook condition. When the dial tone is received, the card is inserted and the START bar is operated. The spring motor wound by insertion of the card pushes the card out of the

dialer past sensing contacts. The contacts determine the dialing frequencies which are generated by the associated touch-tone dial. If the STOP code is punched in the card following the address, the dialing stops when the STOP code is read. The card should then be released by reoperating the START bar. Dialing proceeds much faster than with the pulsing card dialer. As the station connects, the output of the touch-tone dial is disconnected from the Data Set so that there is no hazard connected with improper operation of touch-tone dial or card dialer at that time.

3.18 The touch-tone multifrequency signal generator is a one transistor oscillator generating two frequencies any time a single push button is operated. Seven frequencies are provided, with each dial digit corresponding to two frequencies according to the table below:

Touch-Tone Frequencies CPS	Dial Digits		
	1209	1336	1477
697	1	2	3
770	4	5	6
851	7	8	9
941		10	

3.19 When the station is idle, a current of about 25 MA flows from ground through RT resistance of point 1 of the touch-tone dial; then through varistors RV3 and RV4, resistor R1, and out of point 6 to -20 V in the Data Set. The transistor Q1 is energized so that there will be no click when the circuit starts to generate the MF signal. The oscillations are suppressed by DC current through the tank coils T1 and T2 maintained by the potential difference across RV4. By interrupting this initial coil current the oscillation's build up time is minimized.

3.20 To dial a digit, a push button on the dialing plate is operated. This closes two frequency determining contacts, one for the T1-C1 tank circuit, and the other for the T2-C2 tank circuit. The Common Switch operates in following sequence:

- (1) y-z contacts open, making the loudspeaker amplifier input available to MF signal only.
- (2) s-t contacts close, and establish a path from the loudspeaker amplifier, through the sending amplifier in the Data Set, and into the line. The feedback through the receiving buffer amplifier in the Data Set back into the

loudspeaker amplifier is disabled by previously opened y-z contacts.

- (3) w₂-v contacts open, disabling the receiving buffer amplifier in the Data Set. This eliminates a possibility of false connect due to MF signals.
- (4) q-p contacts open, together with w₂-v contacts, resetting the dial tone detecting circuit when furnished.
- (5) w₁-u contacts open, interrupting the DC current through the tank coils. Since the tanks T1-C1 and T2-C2 are coupled to the coils in Q1 circuit, the unit starts oscillating with a very short build-up time.

The same functions could be assured with w₂-v contacts operating first and y-z contacts eliminated. However, the interruption of current in the primary coil of the input transformer in the loudspeaker amplifier would cause a loud click to be heard every time a digit is dialed.

3.21 The frequencies above 1000 cycles per second are generated at a somewhat higher level to compensate for greater line loss at those frequencies. Also, there is a variation of amplitude for various digits. The PT resistor is set at the time of assembly of the attendant circuit with the Data Set for an output of 0 dbm on the line for the digit with highest output level.

Touch-Tone and Card Dialer

3.22 To use the automatic card dialer, the ORIG key is operated. After the dial tone has been received, a punched card is inserted into the slot and pushed down. The START bar is then momentarily operated. The card dialer proceeds with dialing under power of a spring motor wound by insertion of the card. When a STOP code is read, the dialing stops. The card should then be released by reoperating the START bar.

3.23 As seen in the wiring diagram, the sensing contacts in the card dialer are in parallel with the frequency determining contacts in the associated touch-tone dial. As the card advances out of the slot, the sensing contacts which sense the holes punched in the card determine the proper frequencies to be transmitted. This occurs for every row on the card. The normally opened E contacts in the card dialer are placed across the excitation w₁-u contacts in the TTD. When dialing manually, the E contacts are opened and there is no interference

from the card dialer. With the card down in the slot, the operation of the START bar closes the E contacts and operates the common switch, through mechanical linkage, for the duration of dialing. The common switch connects the input and output circuits of the loudspeaker amplifier as described in Par. 3.20. Opening of the w_1-u contacts transfers the excitation function to the E contacts in the card dialer. As the card advances out of the slot, the E contacts open for each row exciting the TTD into generating the MF dial signals.

3.24 During dialing, there are short intervals of time when all the sensing contacts are opened and the E contacts are open. Therefore, the TTD will break into spurious oscillations somewhere between 7 KC and 14 KC. Although this frequency band is suppressed by the telephone line, these frequencies would be noticeable on the loudspeaker. The action of capacitors CT and C4A in the loudspeaker amplifier combine to suppress this spurious signal from reaching the loudspeaker.

3.25 Since the card advances out of the slot very rapidly, there is no need for a separate release bar. When the station connects, relay contacts in the Data Set (CON 8 in 101C) disconnect the MF signal input and remove any hazard connected with false operation of the MF dials.

D. Answering a Call - Manual and Automatic Manual Answering

3.26 Refer to Par. 2.08, in this section, for a discussion of this circuit.

Automatic Answer-Back

3.27 Refer to Par. 2.09, in this section, for a general discussion of this circuit.

3.28 **Circuit Description:** The answer-back drum is allowed to rotate by pulsing the armature coil from either the Data Set, WRU contacts in the page printer stunt box, or the HERE IS key.

- (a) When the Data Set at an answering station makes a complete connection to the sending station, it applies a ground to the answer-back coil circuit and allows the coil to energize and trip the answer back. When the drum starts rotating, the answer backoff normal contacts close and allow the non-repeat relay (ABR) to energize. The break contacts on the ABR relay open the pulsing circuit

to the answer-back coil (ABC) and permit only a single operation of the mechanism. The make contacts on the ABR relay provide the holding circuit for the ABR relay until the call has been completed or the circuit interrupted.

- (b) During a call, the ABR relay holding circuit can be interrupted by either the operation of the HERE IS key or by recognition of the WRU code in the stunt box. This interrupting pulse allows the ABR relay to de-energize, allowing the answer-back mechanism to repeat its cycle.

- (c) The page printers at both the sending and receiving stations recognize the WRU code, and the associated stunt box contacts are operated. However, only the receiving station's answer back is allowed to trip. The sending station's answer back is not operated as a result of the WRU contacts being electrically disabled by the non-contention relay (NCT) contacts.

- (d) The non-contention relay is operated by the keyboard universal contact whenever the transmission is from the keyboard. The relay is slow release as a result of shorting its secondary windings by the NCT 6 make contacts. The release time of the NCT relay allows the WRU contacts to operate in the page printer stunt box without interrupting the ABR relay holding circuit. Thus the answer back at the station which originated the WRU does not operate.

- (e) If the set originated the call, the answer back coil must be pulsed to provide operation. Transmitting a WRU character the NCT 12 break contacts interrupt the coil operating circuit through the WRU make contacts. Therefore, no answer-back operation is permitted. When the set receives a WRU and the contacts close in the stunt box the answer-back coil is connected to ground through the NCT 12 break contacts.

- (f) If the set answered the call, the ABR relay holding circuit must be interrupted. Transmitting a WRU the NCT 8 make contacts allow the holding circuit to be continuous throughout the operation of the WRU stunt box contacts. When a WRU is received the WRU break contacts interrupt the ABR relay holding circuit permitting the answer-back mechanism to repeat its cycle.

- (g) The HERE IS key allows the station to operate its answer back. At the originating

station the HERE IS make contacts permit the answer-back coil to energize operating the answer-back mechanism. If the HERE IS key is continually depressed the ABR relay remains energized until the key has been released, providing the non-repeat feature.

(h) At the answering station the HERE IS contacts interrupt the ABR holding circuit allowing the ABR relay to de-energize. When the key is released the answer-back coil energizes permitting the answer back to cycle.

E. Send-Circuit - Signal Regenerator

General

3.29 The KSR can send by operating the keyboard, the answer-back mechanism or the BREAK key. The keyboard signal generator is connected to a signal regenerator which is in turn, connected to the Data Set. The answer back signal generator is in series with the output of the signal regenerator. The BREAK key is connected to the Data Set on separate leads. The signal regenerator is used to improve the signal quality obtained from the keyboard signal generator.

Signal Regenerator Circuit

3.30 The main component of the circuit is a silicon controlled rectifier (SCR) which is controlled by the keyboard timing contacts. The timing contacts are opened by a cam at the middle of each generated pulse from the signal generator, and switch the SCR on or off in accordance with the marking (closed) or spacing (open) condition of the signal generator.

3.31 When the timing contacts are open and the signal generator contacts are closed, the gate current, from +20 VDC through the 10,000ohm resistor and the varistor to the gate, turns the SCR on producing a marking output. The SCR will remain on until the current through it drops below 8 milliamperes. Since the current can pass through either the signal generator marking contacts or the timing contacts the SCR stays on until both the timing contacts and the signal generator contacts are opened simultaneously. The mark to space transition is triggered by the timing contacts and therefore, the output of the SCR is as good as the timing of these contacts.

3.32 The BREAK key sends a spacing signal which the Data Set limits to about 120

milliseconds. Thus the local printer runs open for about 100 milliseconds until the break detector operates, lighting the break release lamp.

F. Receive Circuit

3.33 Refer to Par. 2.13 through 2.18, in this section, for a discussion of this circuit.

G. Disconnecting a Call

3.34 Refer to Par. 2.19 and 2.20 in this section, for a discussion of this circuit.

H. Local Mode

3.35 The local mode provides off-line operation of the set. The operator selects the local mode by depressing the LCL locking key. The LCL key lights the LCL lamp and operates the motor control relay (MCR) to energize the motor. The Data Set connects the sending circuit to the receiving circuit, and enables the keyboard and answer back to transmit to the page printer and the auxiliary ROTR (if one is used). A pair of make contacts on the LCL key operate to disable the turn-around-traffic-control so that the ROTR can receive local traffic in the LCL mode. If the set is in a terminal hunting group, the operator must turn the out-of-service switch to the RESTORE position until a dial tone is received after finishing the operation in the local mode.

I. Out-of-Service Switch

3.36 Refer to Par. 2.21 through 2.22(a), in this section, for a discussion of this circuit. In addition to operating a contact which shorts the tip to ring (Par. 2.22(a)) when in the RESTORE position, the switch also closes a contact which completes a path from the speaker-amplifier system to ground. This permits the amplifier to pass the line signals (dial tone).

J. Low Paper Alarm

3.37 Refer to Par. 2.23 through 2.26, in this section, for a discussion of this circuit.

K. Make Busy Circuit

3.38 Refer to Par. 2.27, in this section, for a discussion of this circuit.

L. Form Feed-Out

3.39 Refer to Par. 2.28 through 2.30, in this section, for a discussion of this circuit.

SECTION 574-227-100

M. Test Mode

- 3.40 Refer to Par. 2.31, in this section, for a discussion of this circuit.

N. Auxiliary ROTR

- 3.41 Refer to Par. 2.32, in this section, for a discussion of this feature.

4. CALL CONTROL UNIT - 35 AUTOMATIC SEND-RECEIVE (ASR) SET

DESCRIPTION (See Figure 3)

- 4.01 Refer to Par. 3.01, in this section, for a description of the Call Control Unit.
- 4.02 Because of the more complex and flexible nature of the Automatic Send-Receive (ASR) Set, a more involved control system is required. Since the call control unit itself is identical to that used on the KSR Set (Par. 3 in this section), the necessary controls are included on the associated electrical service unit. As discussed in Par. 1.03 and 1.04, however, because of the close relationship between the call control unit and the electrical service unit, the operation of these controls will be discussed in this paragraph as though they were a part of the call control unit. Refer to the appropriate section for a description of the associated electrical service unit.

PRINCIPLES OF OPERATION - See WD6000 (ASR)

A. Originating a Call

- 4.03 Refer to Par. 3.05, in this section, for a description of this circuit.

B. Speaker - Amplifier System

- 4.04 For a discussion of this circuit, refer to Par. 3.06 through 3.09 in this section.

C. Dial Mechanisms

Rotary Pulsing Dial

- 4.05 Refer to Par. 3.10, in this section, for a discussion of this circuit.

Pulsing Card Dial

- 4.06 Refer to Par. 3.11 through 3.16, in this section, for a discussion of this circuit.

Touch-Tone Dial

- 4.07 Refer to Par. 3.17 through 3.21, in this section, for a discussion of this circuit.

Touch-Tone and Card Dialer

- 4.08 Refer to Par. 3.22 through 3.25, in this section, for a discussion of this circuit.

D. Answering a Call - Manual and Automatic

Manual Answering

- 4.09 Refer to Par. 2.08, in this section, for a discussion of this circuit.

Automatic Answer Back

- 4.10 Refer to Par. 2.09, in this section, for a general discussion of the answer-back mechanism. Note that the mechanism is not located behind the page printer (as mentioned in Par. 2.09), but is mounted at the rear of the transmitter distributor base and is driven by its own motor unit.

- 4.11 Circuit Description: Refer to Par. 3.28 (a) through (h), in this section, for a discussion of this circuit. Note that the non-contention relay is also operated whenever the transmitter distributor is sending traffic, in addition to operating via the keyboard universal contact (refer to Par. 3.28 (d)).

E. Automatic Mode Switching

- 4.12 Automatic mode switching for the 35 ASR Set provides the:
- (a) Ability to prepare tape while transmitting or receiving traffic,
 - (b) Ability to transmit or receive traffic using codes foreign to the equipment,
 - (c) Ability to receive traffic on tape and by page copy simultaneously,
 - (d) Ability to revert to a common mode of operation when clearing the set or on a break or call disconnect.

To obtain the feature mentioned above, the keyboard and reperforator are switched between the data set signal circuit and the auxiliary local circuit according to the following:

Figure 3 - Automatic Send Receive Set with Call Control Unit

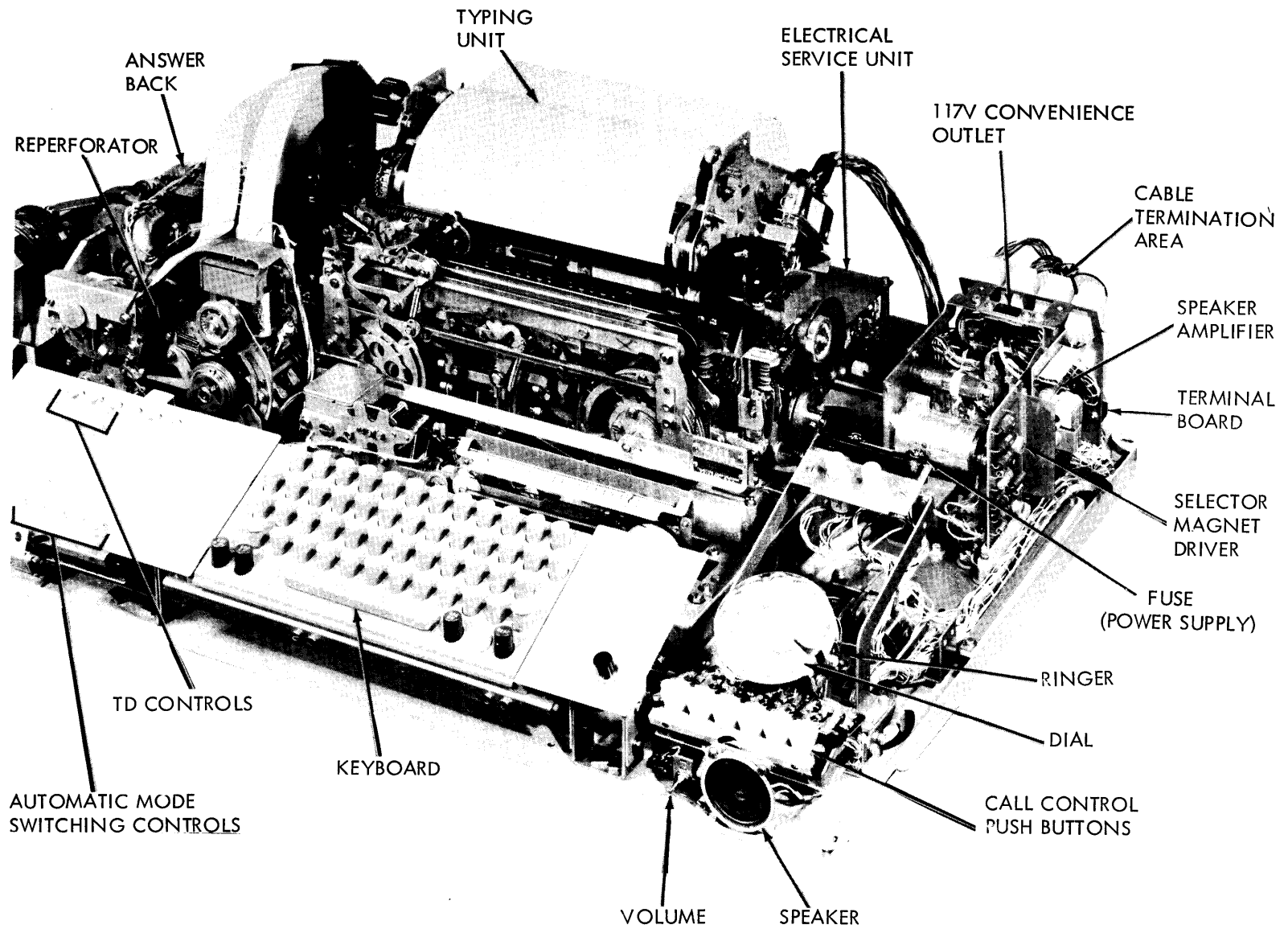

MODE	TD	KBD	LRPE	LP
K	*	L	O	L
KT	L	L	L	L
T	L	O	O	L
TTs	L	O	O	B
TTr	*	O	L	B

L - Indicates signal line circuit

O - Indicates auxiliary local circuit

B - Indicates unit is blinded in signal line circuit

* - TD is disabled

K - Keyboard

KT - Keyboard - Tape

T - Tape

TTs - Tape-Tape Send (Disabled at customers request)

TTr - Tape-Tape Receive (Disabled at customers request)

4.13 Automatic reversion of all other modes (other than T) to the T mode occurs when the clear key is operated or upon initiating a break or call disconnect (EOT) signal. The set idles in the T mode when not in use. When either originating or answering a call, the set provides the necessary facilities for transmitting or receiving traffic and still provides auxiliary local operation.

4.14 In addition to the five mode keys, a MOTOR ON key has been provided. This key, when in the operate position, allows the set motors to remain on continuously. This feature allows the operator to prepare traffic in the auxiliary local circuit, after the set has been cleared on a call, without introducing garble as a result of the motors turning off. In the MOTOR ON position, the operator does not have the option of switching modes, but is allowed to prepare tape when in the T mode.

4.15 Operation of the LCL key on the call control unit will provide off line operations equivalent to those when the set is in the answer or originate conditions. Depressing either the ANS or ORIG keys when in local mode will revert any existing mode to the T mode of operation.

4.16 Switching from one mode into another is accomplished without transmitting a

character to the line or punched in the reperforator tape. The reperforator is isolated from one circuit before it is switched into the other.

4.17 The components of the ASR Set will operate, depending on the mode selected, as follows:

(a) In the TTs and TTr modes the page printer is blinded by MSP 8 make contacts. These contacts provide a continuous 20 milliamperes signal to the selector magnet driver.

(b) In the KT and TTr modes, the reperforator is connected to the line circuit through the MSR 6 and MSR 10 make contacts. During switching the MSR 2 make contacts provide a continuous 20 milliamperes signal to the selector magnet driver and after switching has been completed the MSR 7 break contacts open this continuous signal circuit.

(c) In the K, KT, and T mode, the page printer is capable of monitoring both transmitted and received traffic.

(d) In the KT mode, the reperforator is also capable of monitoring transmitted traffic for future multiple transmissions.

4.18 All modes are associated with lamps that indicate in which mode the set is operating. The lamps are controlled by the mode switching relays, except the motor on lamp which is controlled by its associated key. For proper operation, a key must be depressed until its associated lamp is lit. The prominent feature of the automatic mode switching circuitry is that it permits simultaneous and uninterrupted performance of two separate operations.

F. Send Circuit - Signal Regenerator

General

4.19 The ASR Set can send by generation of pulses from the keyboard and transmitter distributor signal generators depending upon the mode of operation, the answer-back commutator, and the break key. The keyboard and transmitter distributor signal generators are connected in series to the signal regenerator which relays their outputs to the Data Set. The output from the answer back is in series with the signal regenerator output. The signal regenerator is used to improve the signal quality obtained from the keyboard and transmitter distributor signal generators.

Signal Regenerator Circuit

4.20 Refer to Par. 3.30 through 3.32, in this section, for a discussion of this circuit. Note that, besides being controlled via operation of the keyboard timing contacts, the SCR is also controlled when the transmitter distributor signal generator operates.

G. Keyboard Send Circuits

4.21 Of the five available modes of operation, K (keyboard) and KT (keyboard-tape) are the only two modes where transmission to the signal line is available from the keyboard. The keyboard is connected in the sending circuit through the MSK 8, MSK 2, and MSK 11, make contacts in both K and KT modes. Generated pulses from the keyboard signal generator and timing contacts provide operation of the SCR as described in Par. 4.20.

4.22 In the KT mode, the transmitter distributor is prevented from being accidentally operated, when transmitting from the keyboard, by the NCT 2 break contacts. The NCT (non-contention) relay is energized through the keyboard universal contact which closes every time a key on the keyboard is depressed.

4.23 When a break has been received from the distant station, the keyboard signal generator is shunted by the Data Set. To provide indication of the break condition the BRK RLS lamp, controlled by the Data Set, lights. To provide line operation from the keyboard the operator must depress the BRK RLS key.

4.24 When communicating with slower speed TWX stations, the operator will receive a visual indication to slow down by the restrain (REST) lamp. If the warning is ignored, a break occurs, lighting the BRK RLS lamp. To restore transmission, the BRK RLS key must be depressed.

H. Transmitter Distributor Control and Send Circuits

4.25 The transmitter distributor is capable of sending traffic to the line in the T, KT and TTs modes. With tape in the transmitter distributor, the operation of the TD ON key allows the TDC (TD control) relay to energize through the Tape Out contacts, the MSR 5 and MSK 5 break contacts, (MSR 1 make and MSP 10 break contacts in the KT mode), the TDC 4 and NCT 2 break contacts. After the TDC relay has pulled up, it is held energized through the TDC 5 make contacts to ground. The TDC 2 make contacts allow the

transmitter distributor clutch trip magnets to energize tripping the start clutch. The TD ON lamp is lit through the TDC 1 make contacts.

4.26 The generated pulses from the transmitter distributor signal generator and timing contacts provide the input to the SCR, resulting in signal output to the Data Set. When the tape has completely passed through the transmitter distributor, the tape out contacts open permitting the TDC relay to de-energize. This results in de-energizing the clutch trip magnets and extinguishing the TD ON lamp.

4.27 When requesting a WRU from the transmitter distributor, a set of WRU stunt box break contacts in the sending printer open and allow the TDC to de-energize. The receiving station transmits an X ON code at the end of its identification. This will operate the stunt box make contacts in the originating station's page printer, allowing the TDC to energize. This requirement results in the switch on the transmitter distributor being biased in the run position and, therefore, requiring ON and OFF keys for manual operation of the unit. The originating station is prevented from remotely turning on the answering station's TD by the Data Set.

4.28 Transmitting the X OFF will also turn off the transmitter distributor. When either TAB, VT, or FORM is transmitted, the TD clutch trip magnets are de-energized until the tabbing or form-out operation has been completed.

4.29 The transmitter distributor signal generator is shunted by the Data Set when a break signal has been received from the distant station. The BRK RLS lamp lights, giving a visual indication of the break condition. Transmission is restored by the depression of the BRK RLS key.

4.30 When communicating with slower speed TWX stations, the transmitter distributor is controlled, from sending too rapidly, by the Data Set. The transmitter distributor clutch trip magnet circuit is opened intermittently to restrain transmission. During the time that transmission is restrained, the REST lamp is lit.

4.31 When desired, the set operator may prevent the transmitter distributor from operating upon receiving a stunt box start code. This is accomplished by the TD CALL IN key which, in normal position, prevents the controller from starting the transmitter distributor.

If the operator desires to have the transmitter distributor started by stunt box code, the TD CALLIN key is twisted to the ON position. Make contacts on the key permit the TD call in lamp to light.

I. Receive Circuits

4.32 The Data Set supplies a 20 milliamperere DC signal to the selector magnet drivers associated with the page printer and reperforator. The selector magnet drivers are connected in series, and amplify the signal to 500 milliamperes to operate the selector magnets.

4.33 In early production ASR Sets, two different types of selector magnet drivers are supplied:

(1) A constant current driver used to control the page printer selector magnets. For a discussion of this driver, refer to Par. 2.14 through 2.18 in this section.

(2) A non-regulated driver used to control the reperforator selector magnets. Discussion of this driver will be found in Par. 4.35 through 4.39 of this section.

4.34 Provisions have been made for insertion of an auxiliary ROTR selector magnet driver in series with the page printer and reperforator drivers. The ROTR can only be operated in the signal line circuit either manually, by depressing the ROTR ON key, or by printer stunt box make contacts. The reperforator can be equipped with turn-around-traffic control which blinds both the reperforator and ROTR to locally generated traffic.

Selector Magnet Driver

4.35 General: The selector magnet driver is a two stage transistorized amplifier capable of switching high output currents (0.500 ampere) at very closely controlled input current levels. The output of the driver is adjustable to 0.500 ampere output, but may change slightly due to normal supply voltage and component variations.

4.36 Open Line: When the line circuit is open (SPACING), transistor Q1 will be turned on by the regulated current flowing through R1 into its base. This current, which is controlled by R1, will be set near the desired switching level. With Q1 conducting Q2 will be cut off, since the potential at the base of Q2 will be more positive than at the emitter. In this condition,

only small leakage currents will flow in the collector circuit.

4.37 Space - To - Mark Transition: As the SPACE-TO-MARK transition begins, the negative bias current flowing in the base of Q1 is diverted to the line circuit. As the line current rises toward the MARK current value, it extracts base current from Q1. When the line current approaches the total current supplied to the base of Q1 to within 0.001 ampere, which is about half the nominal MARK current value, Q1 begins to turn OFF. Q2 will then begin to receive forward bias current from R3 and begin to turn ON. The base current will then be amplified by Q2, and a current which is a multiple of the base current will appear in the emitter circuit. This increase in emitter current results in an increase in the negative potential measured across R4. The emitter of Q1 will then go negative at the rate of increase of the current in Q2. This negative voltage feedback causes Q1 to go further into cutoff, allowing more current to be passed into the base of Q2. The feedback process continues until the current in Q2 reaches a value which is limited by the resistance in series with its collector-emitter circuit. As the line current rises past the halfway point, the base of Q1 will become positively biased. The positive bias current will be approximately equal to the line current minus the input bias current. The positive voltage developed will be clamped by the input, protecting varistor CR1 to approximately 0.6 volts.

4.38 Mark-To-Space Transition: The line current in changing from MARK-TO-SPACE will finally reach the point where R1 will begin to supply some forward current to the base of Q1. The line current level at which this occurs will be a little more negative than the point at which the circuit switched from space to mark due to the common emitter resistor voltage feedback. As Q1 begins to turn ON, the current through R3 will be diverted from the base of Q2 causing it to begin to turn OFF. As Q2 turns OFF, the voltage across R4 will begin to go positive, causing Q1 to be further turned ON. This effect gives regeneration to the MARK-TO-SPACE transition.

4.39 Mark - To - Space Switching Transient: When Q2 is turned off during the MARK-TO-SPACE transition, a negative voltage transient is developed at its collector. This transient is due to dissipation of the energy stored in the magnetic field of the driven magnet when energized by 0.500 ampere. If the high voltage developed at the collector of Q2 is not limited,

it would continue to rise until the collector-to-emitter reach through breakdown voltage is exceeded. It has been found that repeated breakdown of this kind causes deterioration of the transistor and finally a collector-to-emitter short circuit. Therefore, it is necessary to provide a transient suppressing network at the collector of Q2. The transient suppression network presently in use is a compromise which affords a minimum peak voltage combined with a magnet release time which provide for adequate printer margins. The network consists of C1 in parallel with R5. CR3 isolates the network from voltages more positive than negative battery potential.

J. Auxiliary Local Circuits

4.40 The T and TTs modes provide the necessary facilities for secondary sets operation. In the T mode, the keyboard and reperforator are linked together in a 40 VDC, 20 milliampere auxiliary local circuit through the MSR 4, MSR 10, MSK 4, and MSK 7 break contacts. While in this mode, the operator can prepare traffic for future transmission while the printer is monitoring incoming traffic (or traffic being transmitted from the transmitter distributor).

4.41 The TTs mode is useful for transmitting foreign coded traffic, and provides the same auxiliary local circuit as the T mode does. In the TTs mode, the page printer is blinded by a continuous 20 milliamper DC signal.

K. Disconnecting a Call

4.42 Refer to Par. 2.13 through 2.18, in this section, for a discussion of this circuit.

L. Local Operation

4.43 Local operation permits the set to operate in an off line circuit. The operator selects the local operation by depressing the LCL locking key which lights the LCL lamp and energizes the motor control relay (MCR), turning on the set motors. The Data Set connects the sending and receiving circuits together enabling the keyboard, transmitter distributor,

and answer-back mechanism to send to the page printer and reperforator (depending upon the mode of operation). The turn-around-traffic-control is disabled, by make contacts on the LCL key, allowing the reperforator and the auxiliary ROTR (if one is used) to receive the locally generated traffic.

4.44 If the set is in a terminal binary group, the operator, when she has completed the local operation, must turn the out-of-service switch to the restore position until dial tone is received. When the set is in local, any operating mode may be chosen. The operator may prepare traffic for future transmission while monitoring (or not monitoring), or make multiple tapes of any traffic simultaneously if an auxiliary ROTR is used.

M. Out of Service Switch

4.45 Refer to Par. 3.36, in this section, for a discussion of this circuit.

N. Low Paper Alarm

4.46 Refer to Par. 2.23 through 2.26, in this section, for a discussion of this circuit.

O. Make Busy Circuit

4.47 Refer to Par. 2.27, in this section, for a discussion of this circuit.

P. Form Feed-Out

4.48 Refer to Par. 2.28 through 2.30, in this section, for a discussion of this circuit.

Q. Test Mode

4.49 Refer to Par. 2.31, in this section, for a discussion of this circuit.

R. Auxiliary ROTR

4.50 Refer to Par. 2.32, in this section, for a discussion of this circuit.

35 CABINETS FOR KEYBOARD SEND-RECEIVE (KSR) AND RECEIVE-ONLY (RO)

TELETYPEWRITER SETS

DESCRIPTION AND OPERATION

CONTENTS	PAGE
1. GENERAL	1
2. DETAILED DESCRIPTION AND OPERATION	5
LOWER CABINET - TABLE AND FLOOR MODELS	5
UPPER CABINET (COVER) - TABLE AND FLOOR MODELS	7
WALL MOUNTED CABINET	9

1. GENERAL

1.01 This section is reissued to rearrange the material and to add the 35 wall mounted cabinet. Since this reissue is of a general nature, marginal arrows have been omitted.

1.02 The 35 Keyboard Send-Receive (KSR) and Receive-Only (RO) Teletypewriter Sets are available in several configurations to meet varying installation and operational requirements. Physical dimensions of each enclosure are listed in Table 1.

1.03 The table and floor model cabinets are identical except the cabinet pan rests on a stand (pedestal) on floor models, and any flat surface on table models. The wall mounted cabinet is intended for installation directly to a wall surface.

1.04 The pedestal provides for housing an apparatus mounting rack structure, designed to mount the standard relay panels. The rack is shown installed in the pedestal in Figure 2.

1.05 The various units of the table and floor model sets are shown installed on the cabinet pan in Figure 4.

TABLE 1. ENCLOSURE DIMENSIONS

Set	Height (Inches)	Width (Inches)	Depth (Inches)
Floor Model (With Call Control Unit)			
KSR	38-1/2	24	24
RO	38-1/2	24	24
Floor Model (Without Call Control Unit)			
KSR	38-1/2	20	24
RO	38-1/2	20	24
Table Model			
KSR	13-1/2	20	24
RO	13-1/2	20	24
Wall Mounted Model			
KSR	31-3/4	16-1/2	14-1/4
RO	31-3/4	16-1/2	10-1/2

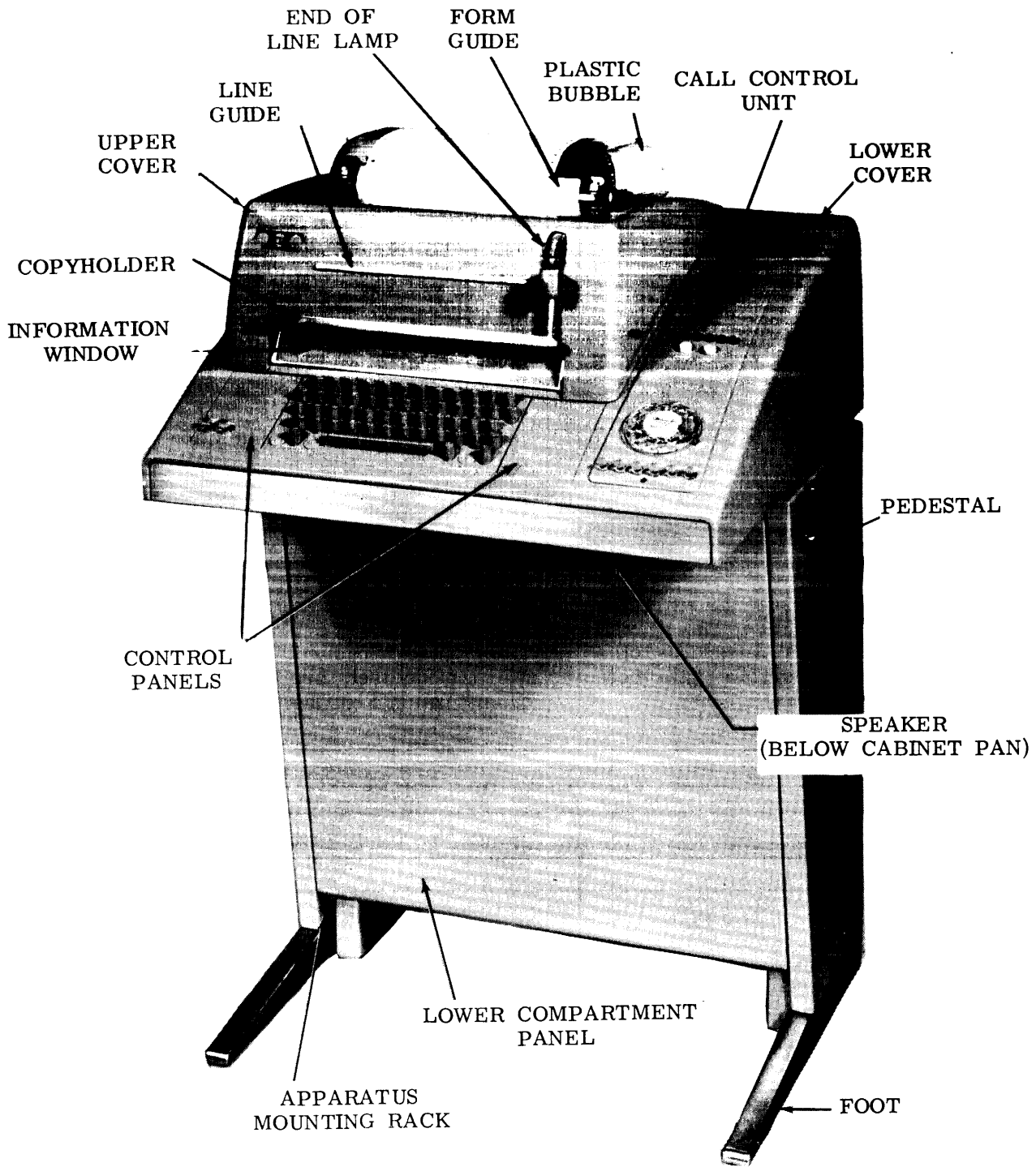

Figure 1 - 35 Keyboard Send-Receive (KSR) Set

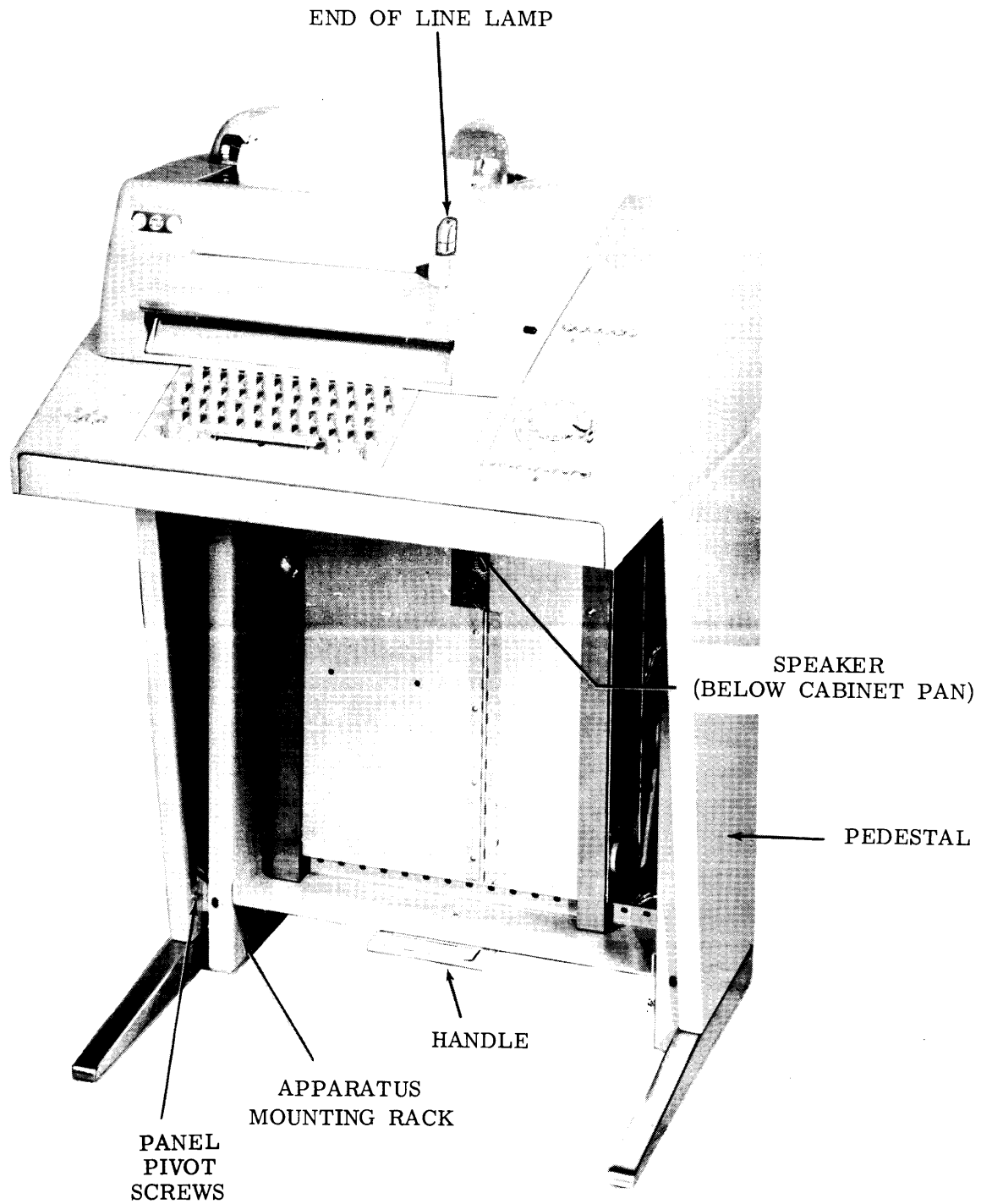

Figure 2 - 35 KSR Cabinet With Apparatus Mounting Rack

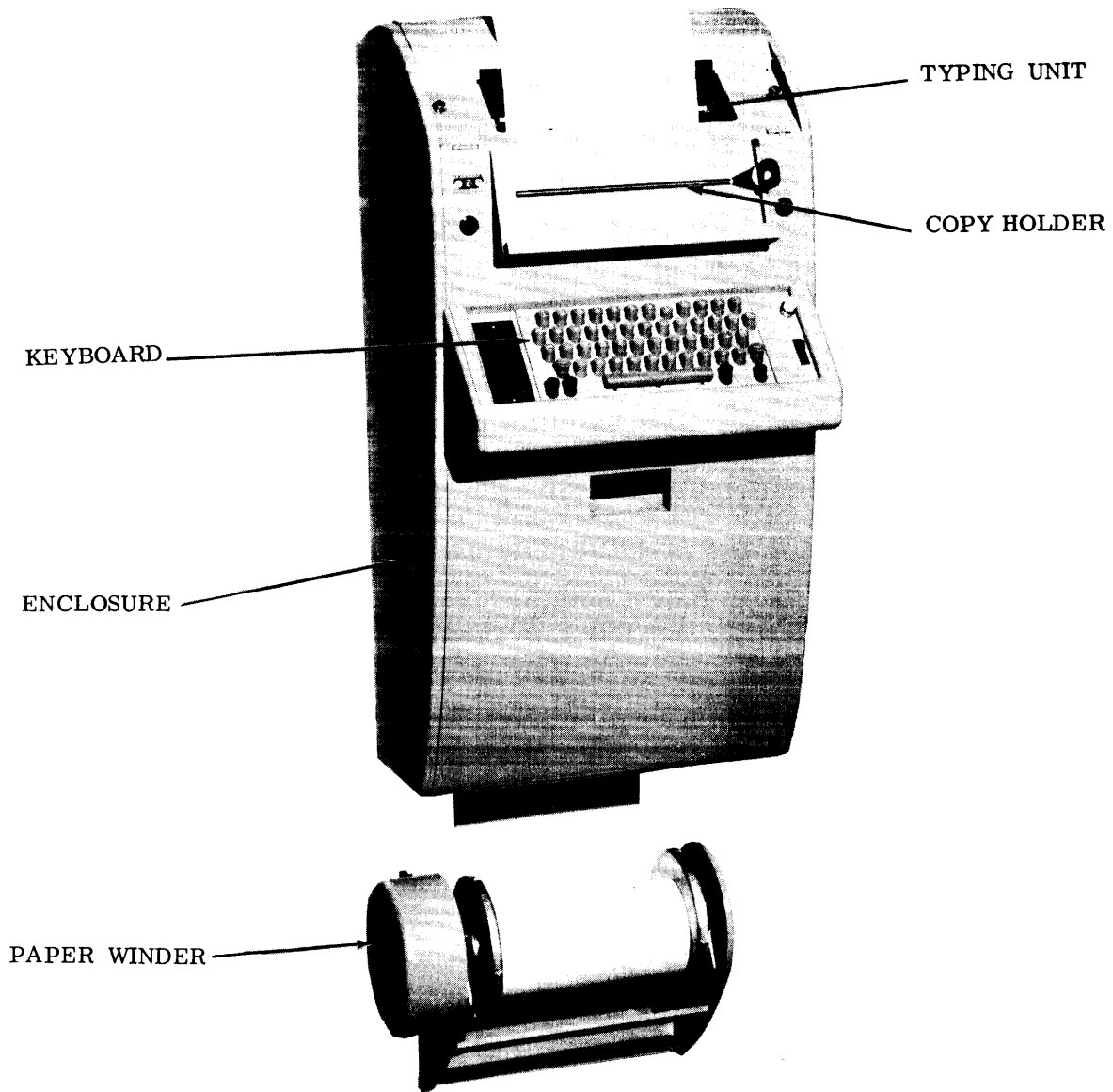

Figure 3 - 35 KSR Wall Mounted Cabinet

2. DETAILED DESCRIPTION AND OPERATION

2.01 The cabinets consist of the following parts and subassemblies:

(a) Lower Cabinet - Table and Floor Models

- (1) Pedestal with pan and feet. Pan only on table models.
- (2) Lower compartment panel. Floor model only.
- (3) Left and right control panel mounting bracket assemblies. Table and floor models.
- (4) Cradle with vibration isolators and base mounting parts. Table and floor models.
- (5) Call control mounting brackets. Floor model only.
- (6) Signal bell. Floor model only.

(b) Upper Cabinet (Cover) - Table and Floor Models

- (1) Lower cover.
- (2) Hinged upper cover.
- (3) Upper cover latches.
- (4) Information window.
- (5) Paper routing access door on bubble.
- (6) Copy light and cable assembly.
- (7) Upper cover counter balance assembly.
- (8) Copyholder.

Note: Floor model cabinets used with sets that print data on continuous business forms should be equipped with rearward extending feet to prevent tilting of the enclosure due to the weight of the form container on the back of the cabinet.

(c) Wall Mounted Cabinet

- (1) Cover.
- (2) Back plate assembly.

- (3) Frame assembly.
- (4) Upper hinged window lid and main cover lid.
- (5) Information window.
- (6) Copyholder tray.
- (7) Lower hinged door and latch.
- (8) Paper chute.

LOWER CABINET - TABLE AND FLOOR MODELS (Figures 1 and 2)

2.02 The pedestal is of simple sheet metal box type construction. The top of the pedestal is ribbed for added strength. The equipment supporting pan is spot welded to the top of the pedestal, and two feet are assembled to the bottom of the pedestal. Two brackets spot welded to the bottom of the pedestal, one on each side, serve as attachment points for the apparatus panel mounting rack. The top of the rack is fastened to an adjustable bracket at the top of the pedestal. A hole with welded nut is provided for mounting the right end of the electrical service unit. A slot at the left rear has a sliding nut which is used to fasten the left end of the electrical service unit. The slot is provided to accommodate electrical service units of varying length. At the right rear of the pan is an opening for routing cables to the lower compartment, and a ground screw for attaching ground leads. Two hand grips are provided in the rear of the pedestal.

2.03 Two fillister head screws are mounted in the sides at the bottom front of the pedestal. The heads of these screws serve as pivots for the lower compartment panel. The pivot brackets on the lower compartment panel are slotted so that the panel is easily removed. The top of the panel is fastened to the top of the pedestal by means of a push button fastener.

2.04 In the front of the pan are the control panel mounting bracket assemblies. These assemblies consist of two upper brackets and a lower bracket. The lower bracket has enlarged mounting holes to provide front to back and side to side adjustment of the control panels. The upper brackets have enlarged mounting holes and mount to the sides of the lower bracket to provide for vertical and angular adjustment of the control panels. The control panels are attached to the upper brackets by means of shoulder screws. The panels may be removed and replaced without readjustment of the brackets.

2.05 The cradle consists of two channels with two welded cross pieces. The cradle is mounted to four adjustable bushings which are threaded into two channel brackets welded to the pan. Holes in the pan provide access to bushings from below for adjusting the height of the cradle. The cradle mounting holes are elongated to provide front to rear adjustment of the cradle. The cradle mounting screws also serve to lock the adjustment bushing in place. The vibration isolators consist of a rubber ring and a rubber bushing. The bushing rests on the cradle and protrudes down through a hole in the cradle. The base mounting bracket rests on the bushing and a post welded to the bracket extends down through the bushing. The bushing isolates the

base from the cradle. The rubber ring slips over the bottom of the bushing under the cradle and a washer, lockwasher, and nut secure the base mounting bracket to the cradle. Holes in extensions of the base mounting brackets provide for mounting the base for shipment. Shipping spacers are placed under the holes and between the channel brackets on the pan and the base mounting brackets. Shipping screws then clamp the base mounting brackets directly to the channel brackets, thus immobilizing the vibration isolators for shipping.

Note: The shipping screws and spacers should be removed and discarded at the time of installation.

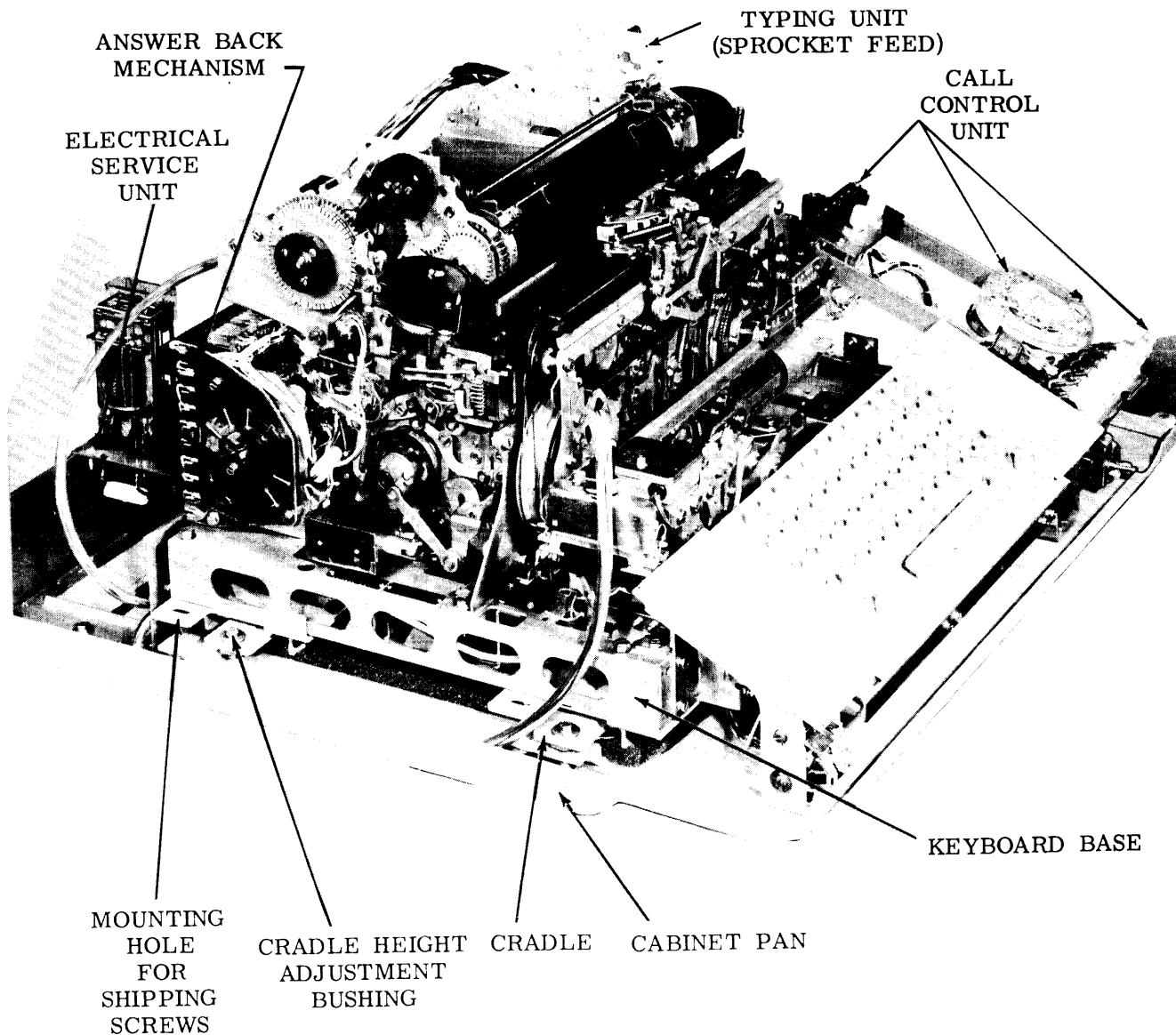

Figure 4 - 35 KSR Cabinet - Cover Removed

2.06 At the right side of the pan are four fixed brackets and one adjustable bracket for mounting the call control unit. The adjustable bracket provides horizontal adjustment of the dial, lights, and push buttons on the front portion of the call control unit so that they are positioned correctly in their respective openings on the bezel. A height adjustment is provided by slots in the call control unit where it mounts to the adjustable bracket. A slot is provided in the pan for access to the bell ringer adjustment on the call control unit. An opening in the pan is provided for the sound from the call control unit loud speaker, which mounts to the pan.

2.07 The signal bell is mounted at the left rear under the pan. Three holes in the pan provide access to the signal bell mounting screws from the top of the pan. The signal bell has two leads with quick connect terminals which plug into terminals on the electrical service unit.

UPPER CABINET (COVER) - TABLE AND FLOOR MODELS (Figures 1 and 2)

2.08 In general, the upper cabinet, composed of a lower and upper cover, is completely removable to provide access to the enclosed

equipment from the top and all sides. The latest designed lower cover is hinged to permit accessibility without removal. The lower cover will clear all of the enclosed equipment when the upper cover is raised and latched to the partially opened position. This requirement is necessary since the lower cover has a low pivot point and free movement of the closed upper cover would be impaired by the enclosed equipment. To insure that the upper cover will be opened before the lower cover is raised, the upper cover must be raised and held open to release the lower cover latch. This latch is located on the right and toward the front of the pedestal and latches the lower cover to the pedestal. A hand grip is provided in the front for raising the cover. The lower cover pivots about two hinge brackets which are mounted to the rear of the pan. A stop bracket locks the two parts of the left hinge together, but can be displaced when removal of the cover is desired. A stop arm located at the left rear of the pedestal limits the backward travel when the lower cover is opened. The stop arm is latching and holds the cover in its fully opened position. The earlier designed lower cover is not fastened, latched or hinged to the pedestal. It is removable from the ped-

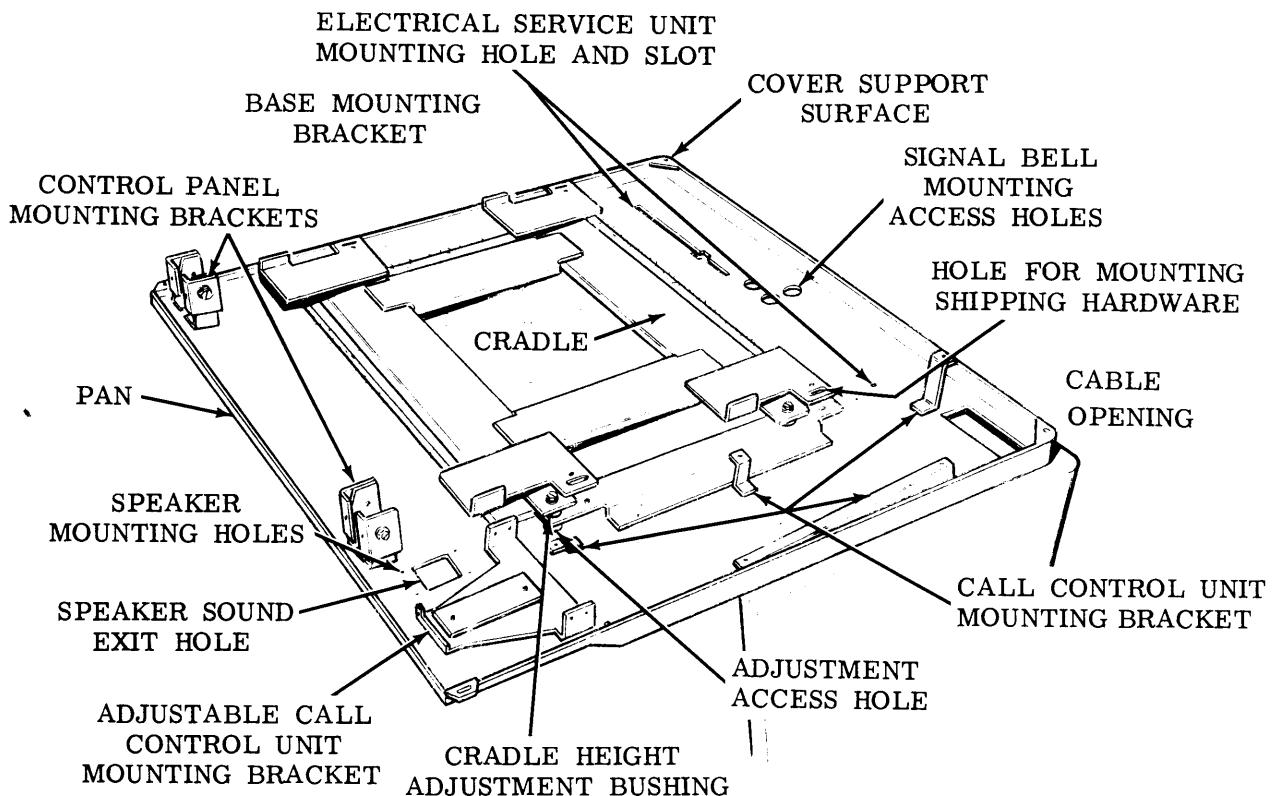

Figure 5 - Pan Assembly

estal by lifting straight up. At the four corners of the pan are surfaces for supporting the cover. The left rear surface has a hole which serves as the prime locating hole while the other surfaces have locating slots. The cover rests on four rubber vibration isolators. The left and right rear and right front isolators have locating pins which fit into openings in the supporting surfaces on the pan to locate the cover. Both earlier and later designed lower covers have paper slots with their individual covers held in place by two mounting nuts. When a sprocket feed typing unit is used, the paper slot cover is removed to allow form feed paper to enter the cabinet through the slot. Two holes on each side of the slot are used for mounting form feed paper guides.

Note: In all 35 type cabinets in which a call control unit is used, remove the call control bezel (Figure 1) before attempting to open or remove the cover. Failure to do so may result in damage to the manual controls that extend through the bezel. The copylamp plug should also be disconnected.

2.09 The upper cover is hinged to the lower cover. Its purpose is to provide access to the equipment for installing the paper supply and changing ink ribbons. It is supported by a counter balance on each side which is adjusted

until the cover will remain in any position to which it is opened. A latch mechanism on each side of the upper cover latches it to the lower cover in the closed position. An information window is located in the lower front of the upper cover. The window frame holds the window and its upper part serves as a support for copy held by the copyholder. Two rubber grommets in the front support the upper cover on the lower cover. The copylight cable and bracket form an assembly which is mounted to studs on the inner side of the front of the upper cover just below the window. The cable terminates in a two prong connector which plugs into the electrical service unit.

2.10 The paper routing access door serves as an aid to threading the typing unit paper out of the cover. It is made of a clear plastic. Because of its appearance, it is referred to as the bubble. The bubble pivots at the rear in pivot brackets on the upper cover. Two spring detents in the front of the bubble latch against bearing surfaces in the upper cover to hold the bubble closed when the upper cover is raised. A friction feed paper guide is mounted to the front of the bubble. This guide may be removed and a sprocket feed form guide mounted in its place when a sprocket feed typing unit is used.

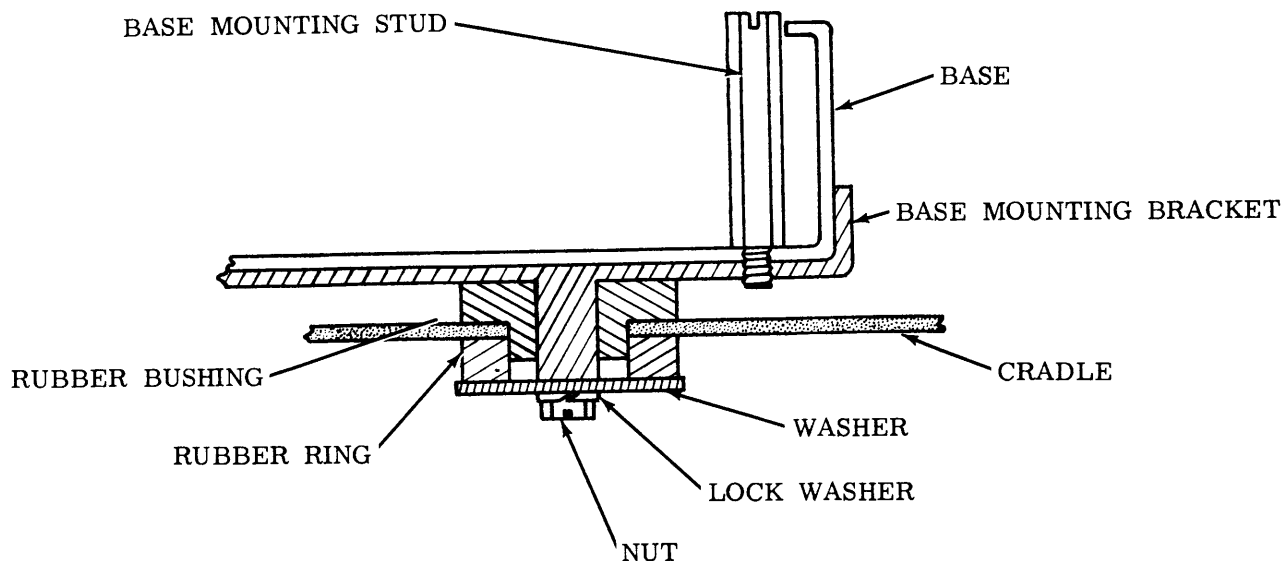

Figure 6 - Base Isolator Assembly

WALL MOUNTED CABINET (Figure 3)

2.11 The wall mounted cabinet is intended for installation directly to a wall surface in areas where it is desired to conserve floor space. Mounting may be made to a variety of wall materials, including: masonry, hollow or solid wood, lath and plaster, plasterboard and tile walls.

2.12 The principle parts of the enclosure are the cover, back plate assembly, and the frame assembly. The upper level of the cover contains a hinged window lid and main cover lid. A laminated glass information window for viewing the printed copy and for use as a copy paper

tearing edge is located in the window lid. The main cover lid may be opened for access to the typing unit ribbon mechanism, typebox and copy paper threading area. The front surface of the cover contains a copyholder tray with an adjustable, combination line guide and retainer. The lower level of the cover has a hinged magnetically latched door, which provides access to the electrical service unit.

2.13 The back plate assembly is used to mount the enclosure to the wall surface. It contains a paper chute and provides support for the frame assembly, to which the cover is secured. One large, centrally positioned isolation mount, and two stabilizing mounts isolate the frame assembly from the back plate assembly.

35 CABINETS FOR KEYBOARD SEND-RECEIVE AND
RECEIVE-ONLY SETS
LUBRICATION

CONTENTS	PAGE	
1. GENERAL.	1	1.04 Use KS7470 oil at all points requiring oil and KS7471 grease at all points requiring grease.
2. LUBRICATION.	2-4	1.05 The unit should be thoroughly lubricated, but over-lubrication, which might allow oil or grease to be thrown to other parts, should be avoided. The following general instructions supplement the specific lubrication points indicated:
Lower cover hinge and latch - (later design only)	3	(a) Apply one drop of oil to all spring hooks.
Upper and lower cover hinge and latch, wall mounted cabinet	4	(b) Apply oil to all pivot points.
Upper cover hinge and latch.	2	(c) Apply oil to all sliding surfaces.
1. GENERAL		1.06 Specific lubrication requirements and the amount of lubricant are indicated at each lubrication point in accordance with the following code:
1.01 This section is reissued to include recent engineering changes and to add the wall mounted cabinet. Since this is a general revision, marginal arrows have been omitted.		O1 Apply 1 drop of oil.
1.02 The 35 Cabinet should be lubricated as directed in this section. The figures indicate the points to be lubricated and the quantity of lubricant to be used. Lubricate the assembly just prior to placing it in service.		O2 Apply 2 drops of oil.
1.03 The cabinet should be lubricated after each six months period of time or after each 1500 hours of service when the operating components of the set are serviced.		O3 Apply 3 drops of oil.
		G Apply thin film of grease.
		1.07 Remove any oil from finished surfaces with a soft clean cloth.

SECTION 574-229-701

2. LUBRICATION

2.01 Upper Cover Hinge and Latch

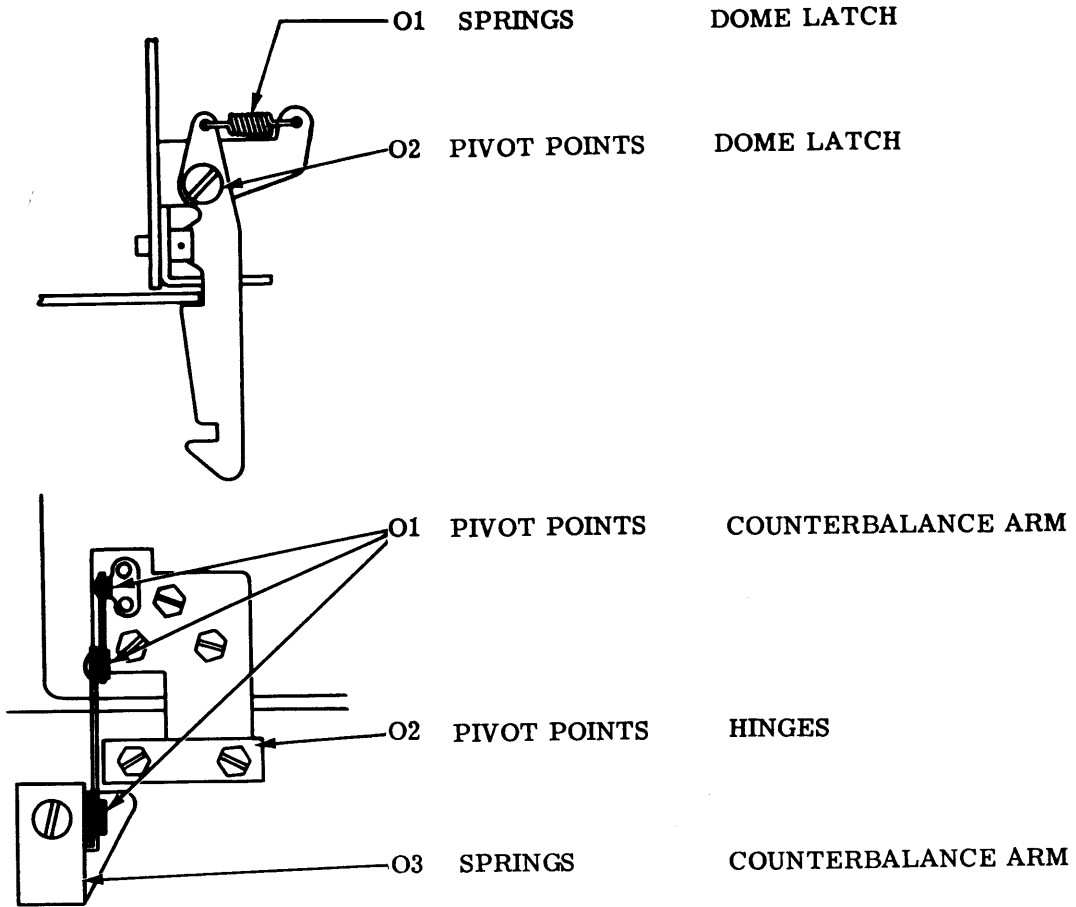

2.02 Lower Cover Hinge and Latch (Later Design Only)

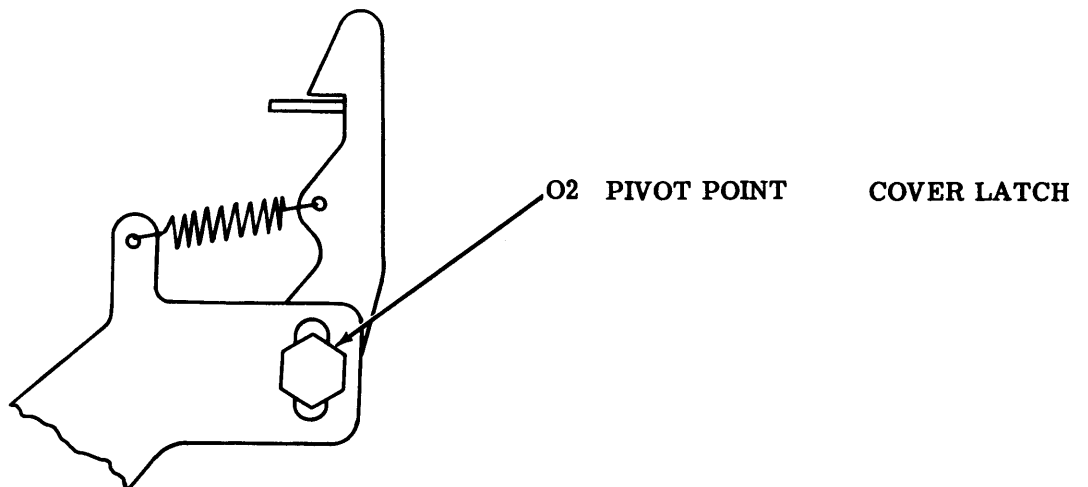
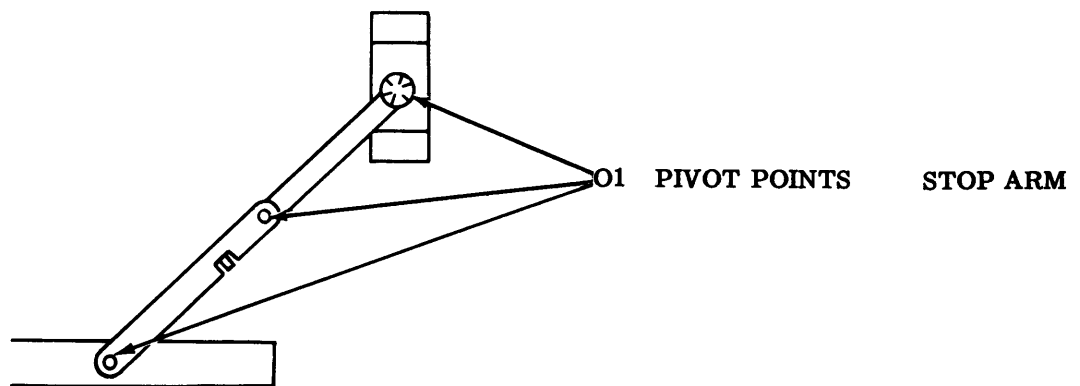
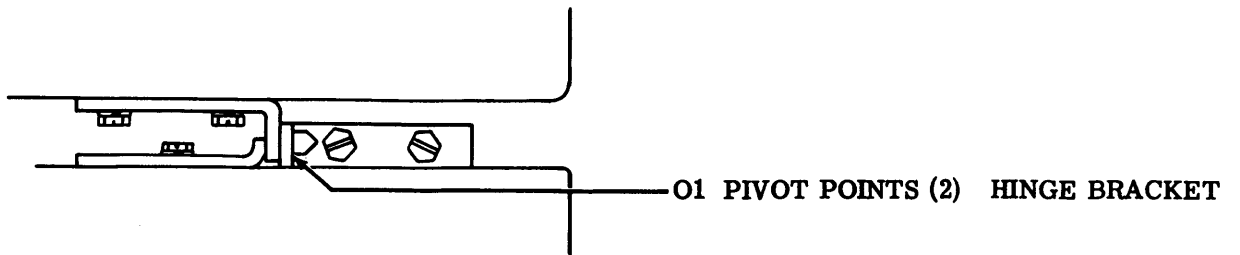

2.03 Upper and Lower Cover Hinge and Latch, Wall Mounted Cabinet

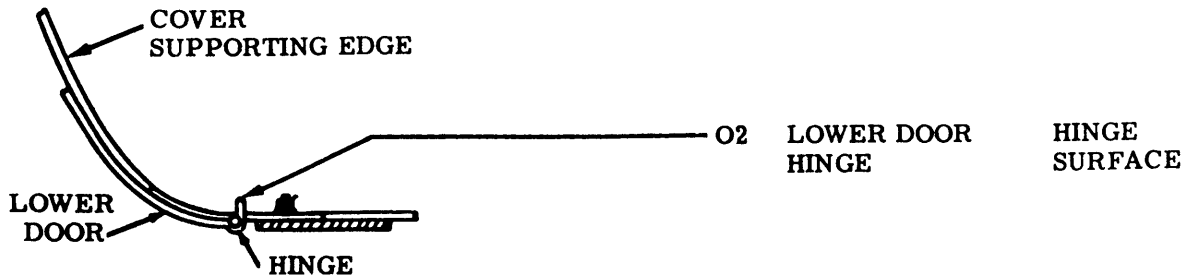
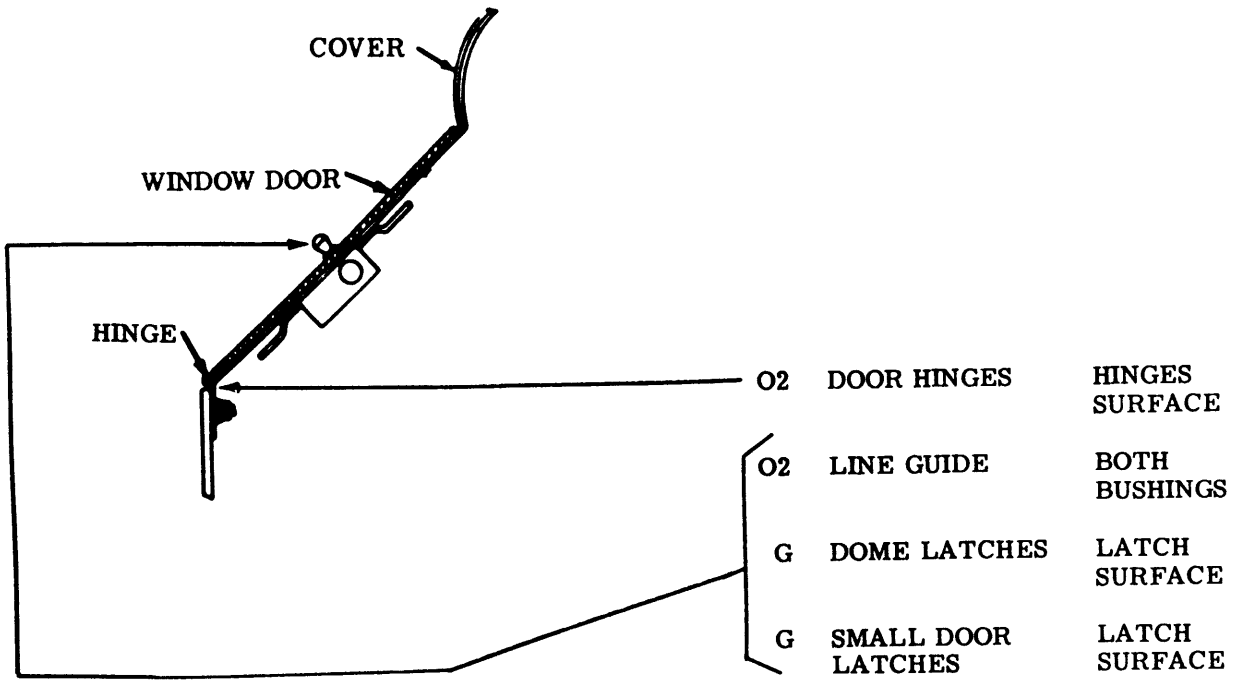

28 AND 35 ANSWER-BACK UNIT
 DESCRIPTION AND OPERATION

CONTENTS	PAGE
1. DESCRIPTION	1
COVER	1
BASE	1
ANSWER-BACK MECHANISM	3
MOTOR	3
GENERAL OPERATION	3
2. PRINCIPLES OF OPERATION	4
TRIP MAGNET	4
MAIN SHAFT	5
SPRING CLUTCH	5
FEED MECHANISM	6
CONTACT BLOCK	7
DISTRIBUTOR	7
3. TECHNICAL DATA	7
A. Dimensions and Weight	7
B. Transmission Codes	8
C. Speeds	8
D. Electrical Requirements	8

1. DESCRIPTION

1.01 This section is reissued to add coverage of the 5- and 8-level answer-back unit. Since this reissue is of a general nature, marginal arrows have been omitted.

1.02 The answer-back unit is an electro-mechanical device designed to transmit a predetermined message of not more than 21 characters. The desired message is precoded on the answer-back drum and is transmitted upon receipt of a request signal. The operational speed of the unit may be fixed at 60, 66, 75, or 100 words per minute by installing the proper gear set.

1.03 It may be mounted, with or without a cover, on any flat surface or on a cabinet, rack, or shelf (Figures 1 and 2). Although it is ordinarily used in conjunction with other teletypewriter equipment, it is mechanically independent of any other equipment. Only electrical connections for power and control cir-

cuits are required. In addition, the answer-back mechanism (Figures 3 and 4) may be mounted in a 35 Automatic Send-Receive (ASR), Keyboard Send-Receive (KSR), or Receive-Only (RO) Teletypewriter Set.

1.04 Variations of the answer-back unit are available for distributing either a 5-level, 7.42, or 7.5 unit code or an 8-level, 11.0 unit code. The 5-level answer-back unit has provisions in the code drum, contact wires, and internal wiring for adapting the answer-back mechanism to an 8-level code. Conversion can be accomplished by changing the distributor disc and making the proper wiring connections.

1.05 Mounting facilities, relay pull-up contacts, and internal wiring are included with the answer-back mechanism for field installation of a nonrepeat relay. The nonrepeat relay is utilized in cases where the duration of the trip pulse is longer than the answer-back cycle. The nonrepeat relay de-energizes the trip magnet at the instant the motor hold and relay pull-up contacts are closed.

1.06 The answer-back unit consists of the cover, base, answer-back mechanism motor, terminal block, fuse, fuse-holder, and capacitor.

COVER

1.07 The cover is sprayed on the inner surface with vibration damping material. In addition, pads are attached to the inner surface for absorbing noise from the operating mechanism. The left end of the cover is louvered to admit air for reducing the operating temperature of the unit.

BASE

1.08 The base provides mounting facilities for the terminal block, fuse, fuse-holder, capacitor, motor, answer-back mechanism, and cover. A pad is attached to the underside of

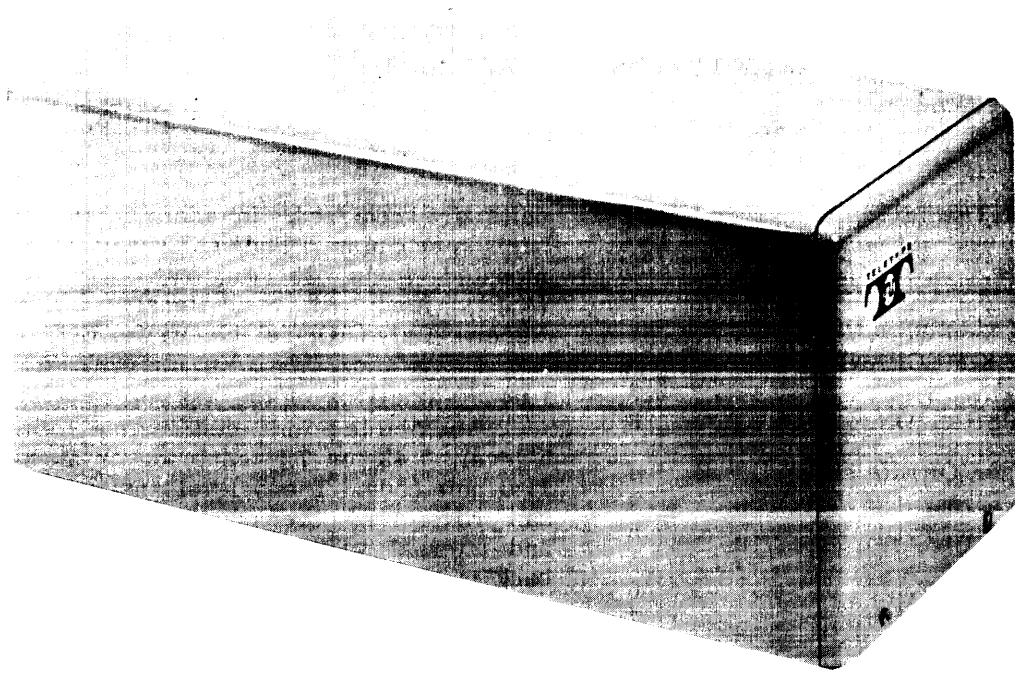

Figure 1 - Answer-Back Unit (With Cover)

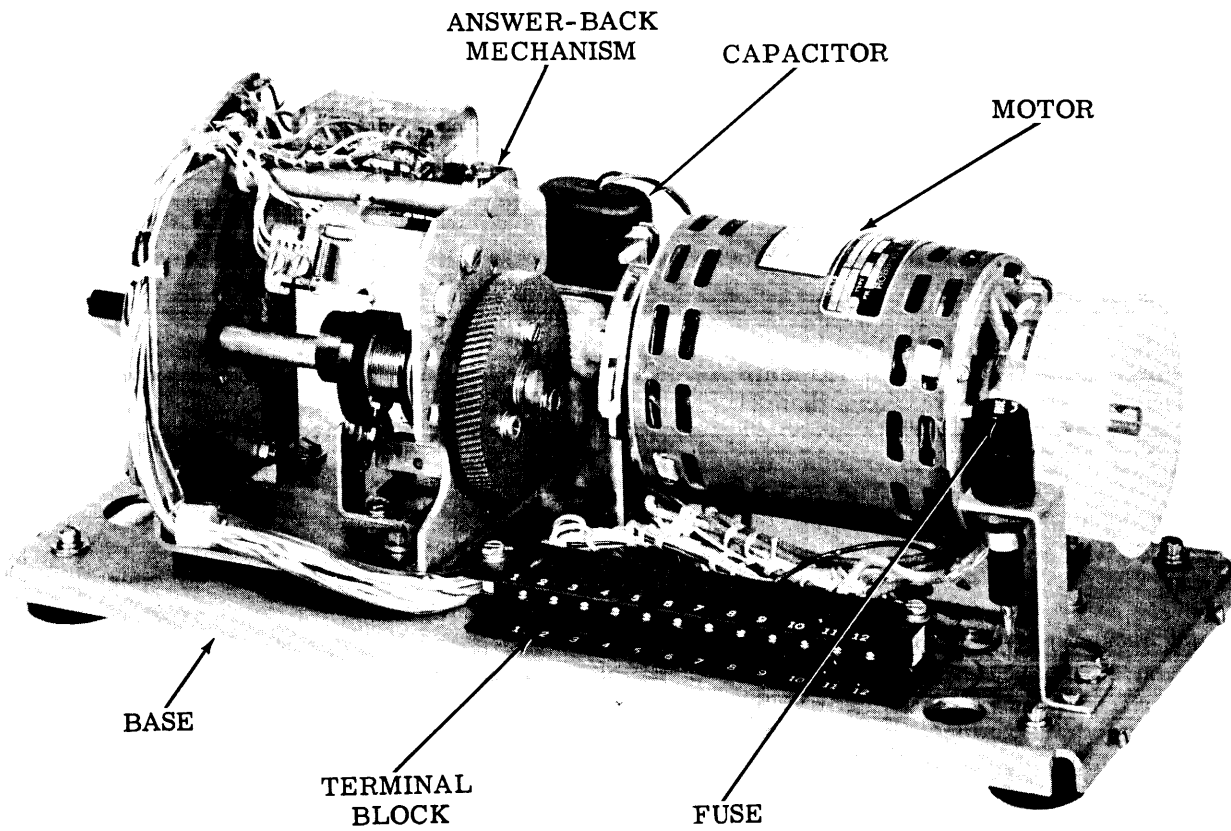

Figure 2 - Answer-Back Unit (Without Cover)

the base to reduce vibration. Four rubber feet support the base.

1.09 The internal wiring harness is attached to the terminal block for external signal, control, and power connections. The block has 12 terminals.

ANSWER-BACK MECHANISM

1.10 The answer-back mechanism may be mounted in the answer-back unit, or a 35 ASR, KSR, or RO Teletypewriter Set. The basic answer-back mechanism shown in Figures 3 and 4, consists of the following parts or subassemblies: trip magnet, code drum, main shaft, feed assembly, contact block, and distributor. The subassemblies are interconnected mechanically and/or electrically to perform all functions incidental to automatic message transmission. In addition, a double set of electrical contacts is provided for motor hold and relay pull-up operations. The motor hold contacts are required for applications where intermittent operation of the motor is both possible and desirable. The relay pull-up contacts apply to the application discussed in Paragraph 1.05.

MOTOR

1.11 A synchronous motor, rated at 1/100 hp and 1800 rpm for 115 ± 10 per cent volts ac operation, is used to drive the answer-back mechanism. The motor is equipped with two windings, a run winding and a capacitor winding for permanent split-phase capacitor operation. The capacitor is encased in metal and has a paper and oil dielectric. A time delay fuse is provided to open the power circuit if the motor is stalled.

GENERAL OPERATION

1.12 Briefly, the parts or subassemblies are interconnected to perform the following functions. An incoming pulse energizes the trip magnet whose armature is deflected to free the code drum, permit the clutch to engage the main shaft, and close a set of contacts. With the main shaft in rotation, the code drum is advanced to the first character position by the feed assembly. The individual contact wires for each code level are automatically set by the precoded character on the answer-back drum. Selected contact wires (marking) touch the common terminal on the contact block for subsequent translation into serial code. Signal power from the terminal block is applied to

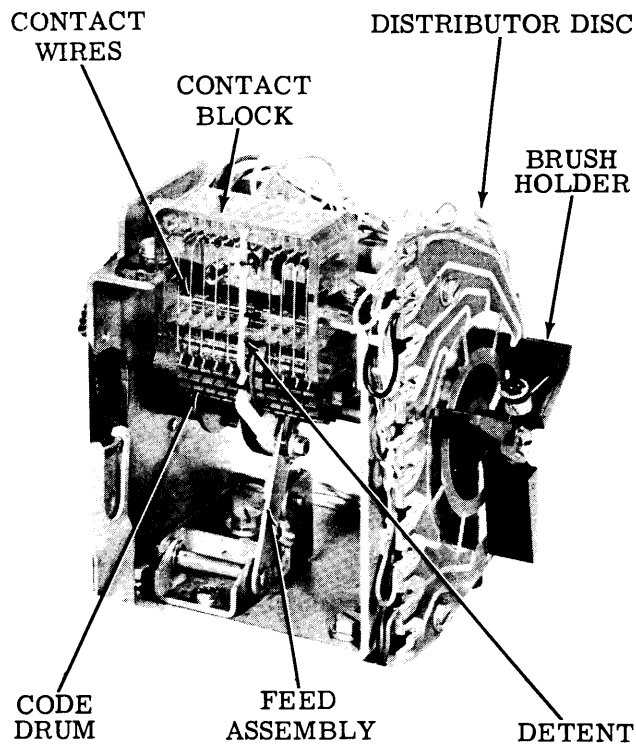

Figure 3 - Answer-Back Mechanism (Rear View)

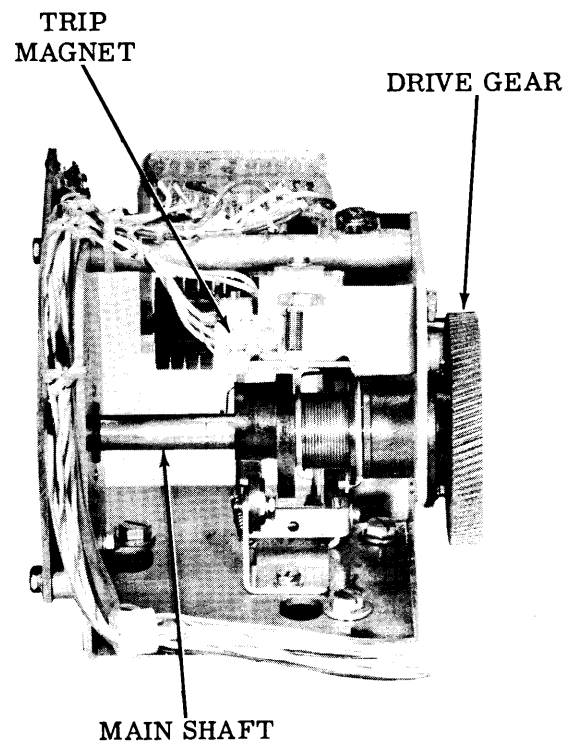

Figure 4 - Answer-Back Mechanism (Front View)

each code level on the contact block through the solid ring on the distributor disc. Each contact wire is sensed as the outer brush on the distributor sweeps its respective distributor segment. All operations necessary for one character transmission, are performed during a single rotation of the main shaft.

1.13 Viewing the code drum with the greater number of radial code tines to the left, there are six numbered (code) levels, feed ratchet, stop control cam, suppression level, and three numbered (code) levels.

1.14 The code drum is designed to function with systems employing 5- or 8-level signal codes. It has 21 rows of code tines and may be coded for one, two, or three cycle operation with message lengths not exceeding 21, 10, and 7 characters, respectively. For applications where the first character is suppressed, the message length is necessarily reduced by one character. The text of the message is further reduced by the number of functions which are peculiar to each system application.

1.15 The contact block, secured to the top rear of the main mounting bracket, contains nine contact wires with provisions for individual cable connections. The common terminal for selected contact wires is located approximately midway between the top and bottom of the contact wires. The detent for limiting the code drum advance to single steps is attached to the contact block.

1.16 The distributor includes a printed circuit with two conducting rings, and a brush holder with two brushes. One conducting ring is solid for applying current. The other ring is segmented with a conducting lead from each segment. The brush holder is fastened to the main shaft. It contains two carbon brushes which are held in place and connected to each other by a spring. One brush rides the solid ring and the other rides the segmented ring.

2. PRINCIPLES OF OPERATION

2.01 The answer-back unit is a self-contained electromechanical device, used for the transmission of a precoded message. The answer-back cycle is actuated when the unit is pulsed by an external request signal.

2.02 Electrical cabling which provides all wiring paths for the power, control, and signal lines is attached to the terminal block on the unit. Mechanical motion for the answer-back mechanism is transmitted through a set of speed change gears. The transmitting speed is determined by the speed change gears. Gear sets are available for operating the answer-back unit at 60, 66, 75, or 100 words per minute. When the motor is running, the answer-back mechanism is held in an idle condition by the disengaged spring clutch on the main shaft.

2.03 The base, fuse, capacitor, and cover are passive components. However, the answer-back mechanism is the principle electromechanical component and is discussed in greater detail in the following paragraphs.

2.04 The answer-back mechanism consists of a trip magnet, main shaft, feed assembly, code drum, contact block, and distributor. An incoming pulse energizes the trip magnet whose armature is deflected to free the code drum, permit the clutch to engage the main shaft, and close a set of contacts. With the main shaft in rotation, the code drum is advanced to the first character position by the feed assembly. The individual contact wires for each code level are automatically set by the precoded character on the code drum. Selected contact wires (marking) touch the common terminal on the contact block for subsequent translation into serial code. Signal power from the terminal block is applied to each code level on the contact block through the solid ring on the distributor disc. Each contact wire is sensed as the outer brush on the distributor sweeps its respective distributor segment. All operations necessary for one character transmission are performed during a single rotation of the main shaft.

TRIP MAGNET

2.05 The trip magnet is attached to the main mounting bracket of the answer-back mechanism as shown in Figure 5. The trip magnet consists of a yoke, magnet core, armature with spring, and electrical contact pile-up. The armature is held away from the magnet core by a spring connecting the rear edge of the armature to the yoke.

2.06 When an incoming pulse energizes the magnet, the attracted armature allows three simultaneous actions to take place. The

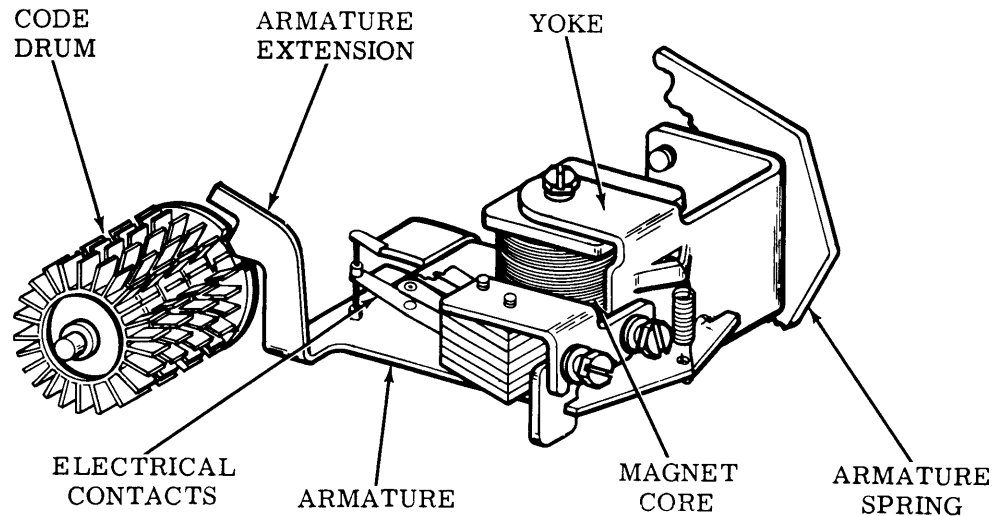

Figure 5 - Trip Magnet

armature extension is extracted from the code drum stop cam; the front edge of the armature permits the clutch release and shaft stop levers to engage the clutch; and the top face of the armature closes a set of electrical contacts. After the incoming pulse has diminished, the armature is physically supported by either mechanical elements on the main shaft or the stop cam on the code drum.

2.07 If the energizing pulse terminates before the code drum is advanced, the released clutch lever supports the armature. The feed takes place within 35 degrees rotation of the main shaft. Then the high part of the code drum stop cam supports the armature extension. When the last character to be distributed appears on the code drum, the motor hold cam, mounted on the main shaft, supports the bottom face of the armature. After distribution of the last character, the motor hold cam allows the armature to fall; the armature extension drops into the opening of the code drum stop cam. As the main shaft continues to rotate, the clutch release lever engages the front edge of the armature, releasing the clutch. Approximately 30 degrees later, the shaft stop lever is engaged to stop the main shaft in a predetermined position.

MAIN SHAFT

2.08 The main shaft delivers rotational motion for advancing the code drum by means of the feed assembly. It also provides rotational motion for distributing the parallel

coded inputs from the contact block. The major elements on the main shaft are the drive gear, spring clutch, and motor hold and feed cam. The distributor brush holder is fastened to the opposite end of the main shaft. The drive end of the main shaft is shown in Figure 6.

SPRING CLUTCH

2.09 The main shaft is separated from the drive gear and clutch sleeve assembly by the spring clutch. See Figure 7. If the trip magnet armature is in the up or run position, the spring clutch engages the rotating clutch sleeve with the main shaft drum. When the armature falls into the stop position, the clutch release lever is engaged first, releasing the clutch, and approximately 30 degrees later, the shaft stop lever is engaged to stop the main shaft in a predetermined position.

2.10 The spring clutch consists of a clutch sleeve, clutch release lever and clutch release lever bearing, retractile spring, shaft stop lever, and shaft drum. One end of the retractile spring is keyed to the shaft stop lever and the other end is keyed to the clutch release lever. The shaft stop lever is secured to the shaft drum which is keyed to the main shaft. The clutch release lever turns freely on the clutch sleeve by means of the clutch release lever bearing. The gear and clutch sleeve assembly, bearing on the main shaft, extends to a plane midway under the retractile spring. The shaft drum, keyed to the main shaft, extends from the clutch sleeve to the shaft stop lever.

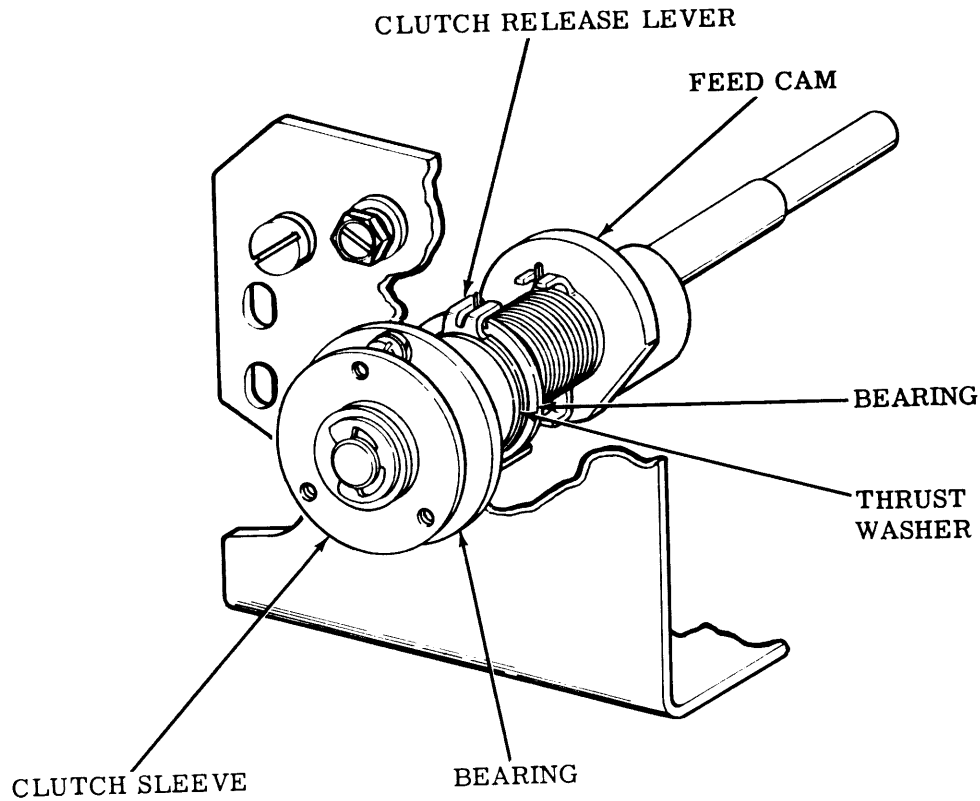

Figure 6 - Main Shaft

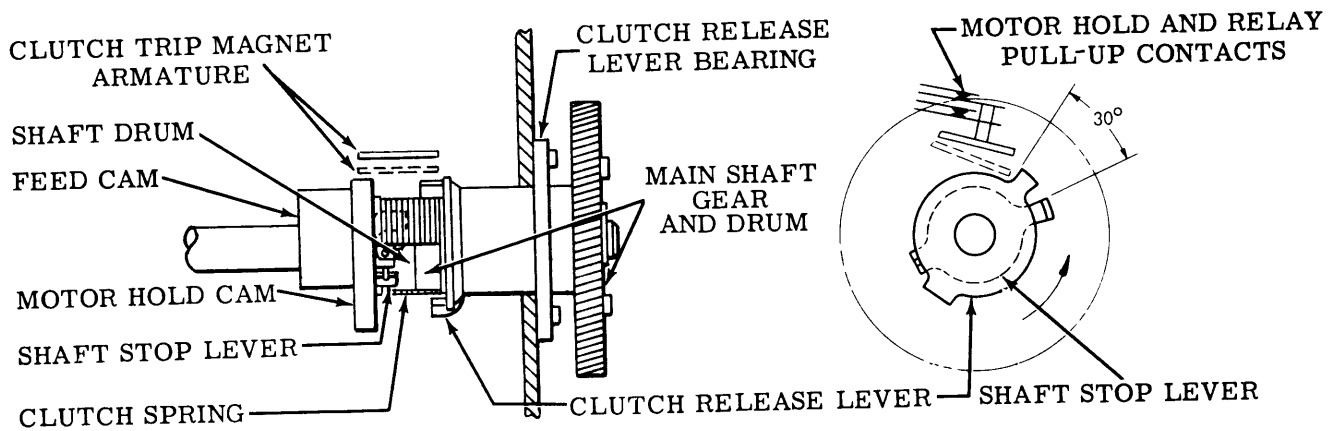

Figure 7 - Spring Clutch

2.11 The retractile spring is mounted over the clutch sleeve and shaft drum with a slight interference fit. When unstressed, the tangs or ends of the spring are approximately 30 degrees apart. As the tangs are forced into alignment, the inside diameter of the spring increases, thereby disengaging the inside surface of the spring from the outside surfaces of the clutch sleeve and shaft drum.

FEED MECHANISM

2.12 The feed mechanism is attached to the base of the main mounting bracket and consists of a feed lever bracket, feed bail, and feed pawl. The mechanism is shown in Figure 8.

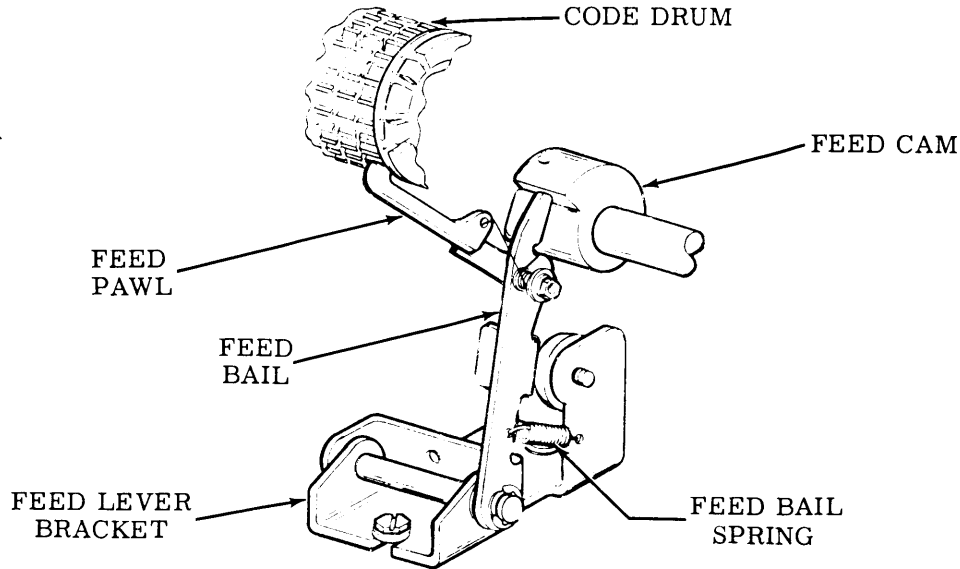

Figure 8 - Feed Mechanism

2.13 At 15 degrees rotation of the main shaft, the feed bail is pulled off the high part of the feed cam by the feed bail spring. Simultaneously, the feed pawl advances the code drum. The code drum is then detented so that the contact wires on the contact block are sensing the first character to be distributed. The feed cycle occurs within an interval of 20 degrees rotation of the main shaft.

CONTACT BLOCK

2.14 The contact block contains nine contact wires with provisions for cable connections, a detent spring, and a common terminal. The code drum is inserted in the slots formed by the contact block extensions. See Figure 3. The common terminal for selected contact wires is located approximately midway between the top and bottom of the contact wires. The contact wires are aligned to follow their respective tines on the code drum.

2.15 Wherever a plastic tine is removed from the code drum, the respective contact wire falls into its slot to meet the common terminal. All effective contact wires representing one coded character, are simultaneously preset at each step of the code drum. Signal current is routed from the terminal block and is sequentially applied to each contact wire through the distributor. The output from the common terminal on the contact block is transmitted over the line as a serial start-stop code.

DISTRIBUTOR

2.16 The distributor consists of a distributor disc and distributor brush holder with brushes. Each effective contact wire on the contact block is connected to its respective segmented level on the distributor disc. The distributor is shown in Figure 3. Signal current is transferred from the inner solid ring to the outer segmented ring through the distributor brushes. The electrical transfer occurs through the torsion spring connecting the set of brushes. The spring serves a double purpose, ie, applies mechanical pressure and provides electrical continuity between the brushes.

3. TECHNICAL DATA

A. Dimensions and Weight

3.01 The external dimensions and weight of the unit are:

- (1) Height - 6 inches
- (2) Width - 6 inches
- (3) Length - 13-1/4 inches
- (4) Weight - 13 pounds

SECTION 574-235-100

B. Transmission Codes

3.02 Data is transmitted by the 5-level answer-back unit in the 7.42 or 7.5 unit code. One start bit, five intelligence bits, and a stop pulse 1.42 or 1.5 bits in length make up the code. The 8-level answer-back unit transmits data in the 11.0 unit code. One start bit, eight intelligence bits, and a stop pulse 2 bits in length make up the code. The 5-level unit may be converted to 8-level operation as previously discussed in Paragraph 1.04.

C. Speeds

3.03 The speed of the answer-back unit is determined by the speed change gears. Gear sets are available in both 5- and 8-level operation for the following speeds shown.

LEVEL	UNIT CODE	SPEED WORDS PER MINUTE	GEAR SET
5	7.42	60 100	TP305047 TP305048
5	7.5	60 66 75 100	TP194808 TP199096 TP194809 TP194815
8	11.0	100	TP194815

D. Electrical Requirements

3.04 Power input to the unit is 110 volts ac \pm 10 per cent or 48 volts dc \pm 10 per cent. The power input circuit is protected by a (slow-blow) 0.80 ampere fuse. Maximum current draw is 100 amperes with either power source. All power, control, and signal lines terminate in a 12-point screw-type terminal block.

28 AND 35 ANSWER-BACK UNIT (LABD)

INSTALLATION

CONTENTS	PAGE
1. GENERAL	1
UNPACKING	1
2. COMPONENTS	1
3. INSTALLATION	1
SPEED CHANGE GEARS	1
POWER AND CONTROL CIRCUITS	2
4. CODING ANSWER-BACK DRUM	2
CODING EXAMPLES	6

1. GENERAL

1.01 This section provides instructions for unpacking, installing, and connecting the self-contained answer-back unit.

1.02 This section has been revised to include recent engineering changes and additions, and to rearrange the text, so as to bring the section generally up-to-date. Since this is a general revision, marginal arrows used to indicate changes have been omitted.

1.03 The unit is mechanically independent of any other equipment. Only electrical connections for power and control circuits are required.

1.04 References made to left or right, up or down, and front or rear apply to the answer-back unit as viewed from the side with the answer-back mechanism to the left and the motor to the right.

UNPACKING

1.05 Open shipping carton carefully. Be sure the carton is resting top side up. Clip any strapping and carefully cut or slit paper tape or fiber carton seals to avoid damage to finished surfaces of the equipment.

2. COMPONENTS

2.01 The self-contained answer-back unit consists of the cover, base, motor, answer-back mechanism, terminal block, fuse, fuse-holder, and capacitor.

2.02 The unit is shipped completely assembled with the exception of the speed change gears which are ordered separately for the desired operating speed. Gear sets are available for both 5- and 8-level operation as shown below:

LEVEL	UNIT CODE	SPEED WORDS PER MINUTE	GEAR SET
5	7.42	60	TP305047
		100	TP305048
5	7.5	60	TP194808
		66	TP199096
		75	TP194809
		100	TP194815
8	11.0	100	TP194815

2.03 The unit may be placed on any hard, flat horizontal surface, or on a cabinet, rack, or shelf. A soft surface or pad should not be used since the free flow of exhaust air will be restricted. The louvered end of the unit should be placed at least one inch from the wall or any other obstructing area which might restrict the air intake.

2.04 The answer-back mechanism is the principle electromechanical component, and may be mounted in the self-contained answer-back unit, or 35 Automatic Send-Receive (ASR), Keyboard Send-Receive (KSR), or Receive-Only (RO) Teletypewriter Set.

2.05 The answer-back mechanism, when mounted in 35-type equipment is normally factory assembled and installed as a part of the base.

3. INSTALLATION

SPEED CHANGE GEARS

3.01 Loosen the cover fastening screws and remove the cover. Remove the screw from the motor shaft and install the pinion. Remove the three gear mounting screws

from the clutch sleeve and install the drive gear. Apply a thin coat of grease on the gears.

3.02 Make the gear mesh adjustment as given in the appropriate section which covers the answer-back unit and mechanism adjustments.

POWER AND CONTROL CIRCUITS

3.03 All electrical connections are made to the terminal block on the base plate. Connections to this block are made with spade-type terminal lugs inserted under the screws on the block. Consult the following wiring diagrams for the 5- and 8-level answer-back units:

(a) 5-level unit – WD4728

(b) 8-level unit – WD6378

4. CODING ANSWER-BACK DRUM

4.01 Figures 1, 2, and 3 illustrate the coding of the answer-back drum. To remove the drum, proceed as follows: Lift the answer-back brace, by means of its extension, to deflect all contact wires and the detent away from the code drum. Hold the feed pawl away, and slip the code drum out. Do not overextend the feed pawl spring.

4.02 The code drum, prior to coding, is identical in either 5- or 8-level operation. As can be seen in Figure 1, three levels are not used when coding the drum for 5-level operation. The tines in these three levels may be left intact, since no contact wire springs sense these positions. When coding the drum for 8-level operation, all levels on the drum are used. See Figures 2 and 3.

4.03 The drum is coded in a counterclockwise direction (viewed from the numbered end), beginning with the start (ST) row 1. Code the drum by breaking and removing the tines as designated in Figures 1, 2, and 3. Either of the two following methods may be used for breaking off tines:

(a) Method 1: Use a screwdriver to remove each tine. Place the end of the screwdriver blade at the base of the adjacent tine. While applying pressure against the base of the adjacent tine, press the side of the blade against the top of the tine to be removed until it breaks. If both tines adjacent to the tine to be removed have been broken off, apply the end of the screwdriver to the stub of either one in breaking off the unwanted tine. This method of removing a tine is indicated in the illustration showing the tine rows in Figures 1, 2, and 3. In the illustration, pressure is being applied to the base of row 20 tine and against the top of an adjacent tine in row 19 to break it off.

(b) Method 2: Use a TP161686 tine tool or a pair of long-nosed pliers to remove each unwanted tine. Place the unwanted tine into slot of the tine tool, or grasp the unwanted tine firmly with the long-nosed pliers, and then, with the tool or the pliers held stationary, rotate the drum back and forth until the unwanted tine breaks off near its base. Use care not to damage adjacent tines.

4.04 The procedures described in the following paragraphs may be altered to suit a particular system or application. Where one character delay is required after the answer-back is tripped off and before the coded message begins, the character suppression tine should be removed in the (ST) start row of the code drum to provide the delay. If the first character suppression is not used, message coding starts on the rows shown coded with character suppression in Figures 1, 2, and 3.

4.05 Normally, a coded message should contain CR (carriage return) and LF (line feed) near the beginning and again near the end of the message. This assures that the transmitted message will appear at the beginning of a line on the receiving teletypewriter set, and that overprinting of the message will not occur. In 5-level operation, the coded message should also contain the "letters" code combination at the beginning of a message to place each teletypewriter set in the unshift position.

4.06 If the suppression tine is not removed in the ST row, the coded message may contain 21 characters for one-cycle operation, 10 characters for two-cycle operation, and 7 characters for three-cycle operation. Unused message coding rows should be coded using the suppression level.

4.07 If the suppression tine is removed, in the ST row, the message length is reduced by one character. The text of the message is further reduced by the number of functions which are peculiar to each system or application. With the suppression tine removed, a station identification message will contain no more than 20 characters, including spaces and nonprinting functions.

4.08 The length of an answer-back sequence can be varied either by removing the characters suppression level tine and/or the stop cam level tine. These two code drum levels, stop cam and character suppression, must always be coded in the same relationship to each other. (See Figures 1, 2, and 3).

4.09 A one-, two-, or three-cycle operation can be obtained by removing the appropriate tines from the stop cam level. Use two- or three-cycle operation for short messages and one-cycle for longer sequences. With the suppression tine removed, two-cycle operation permits 9 characters to be coded in each half of the drum. Three-cycle operation allows 6 characters to be coded in each third.

CODE LEVELS REMOVE TINES	LETTERS	FIGURES TYPICAL ARRANGEMENT	
1-2	A	-	-
1-4-5	B	5/8	?
2-3-4	C	WRU	:
1-4	D	\$	+
1	E	3	3
1-3-4	F	1/4	\$
2-4-5	G	&	&
3-5	H		#
2-3	I	8	8
1-2-4	J	,	BELL
1-2-3-4	K	1/2	(
2-5	L	3/4)
3-4-5	M	.	.
3-4	N	7/8	,
4-5	O	9	9
2-3-5	P	0	0
1-2-3-5	Q		
2-4	R	4	4
1-3	S	BELL	,
5	T	5	5
1-2-3	U	7	7
2-3-4-5	V	3/8	:
1-2-5	W	2	2
1-3-4-5	X	/	/
1-3-5	Y	6	6
1-5	Z	"	"
4	CARRIAGE RETURN		
2	LINE FEED		
1-2-3-4-5	LETTERS SHIFT		
1-2-4-5	FIGURES SHIFT		
3	SPACE		
NONE	BLANK		

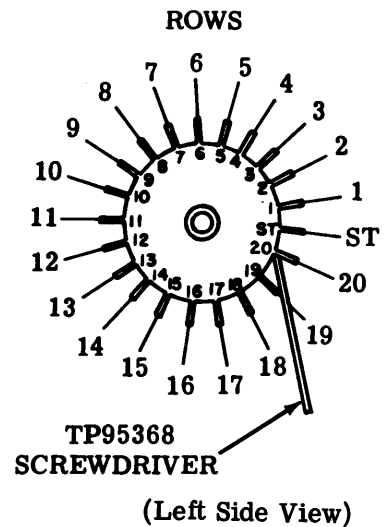
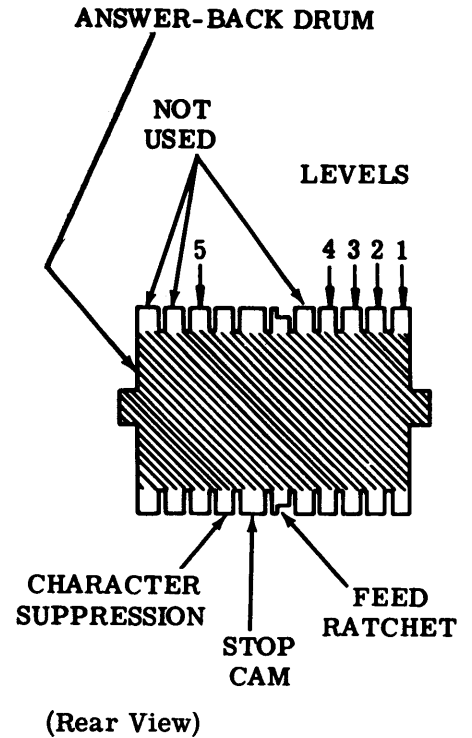

REMOVE TINES AS SHOWN BELOW TO GET PROPER CYCLE		
CYCLES	CHARACTER SUPPRESSION	STOP CAM
1 Cycle	Row ST	Row 6
2 Cycle	Row ST Row 11	Row 6 Row 17
3 Cycle	Row ST Row 7 Row 14	Row 6 Row 13 Row 20

Note: Remove tine — marking.
Leave tine — spacing.

Figure 1 - Coding of Answer-Back Drum - 5-Level Teletypewriter Code

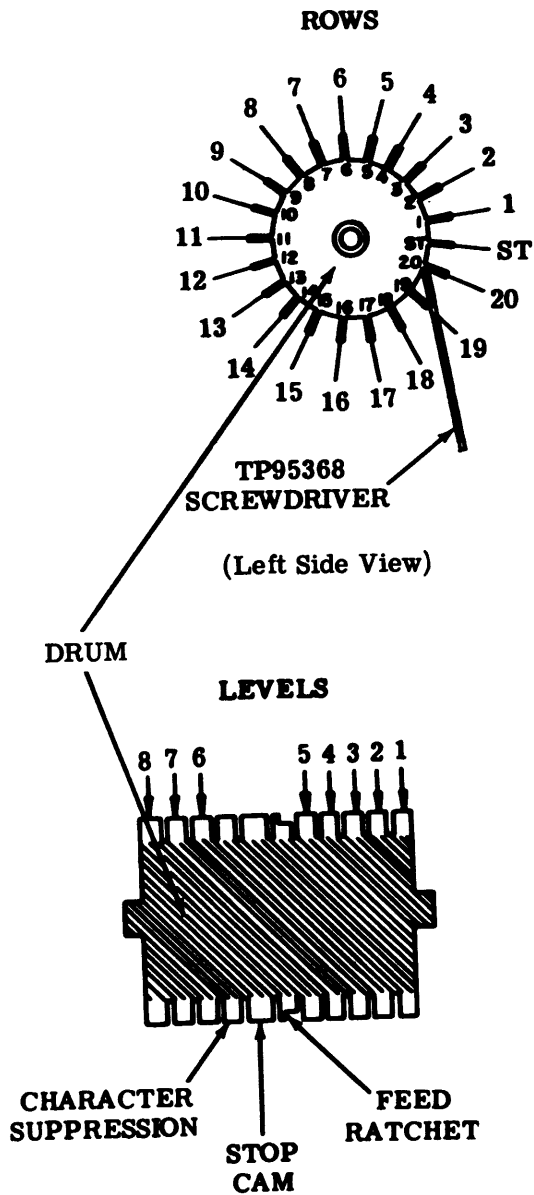

REMOVE TINES AS SHOWN BELOW TO GET PROPER CYCLE		
CYCLES	CHARACTER SUPPRESSION	STOP CAM
1 Cycle	Row ST	Row 6
2 Cycle	Row ST Row 11	Row 6 Row 17
3 Cycle	Row ST Row 7 Row 14	Row 6 Row 13 Row 20

Figure 2 - Answer-Back Drum

CODE LEVELS REMOVE TINES	ASCII CODE			CODE LEVELS REMOVE TINES	ASCII CODE		
	Bell System Usage	1967 Edition	1963 Edition		Bell System Usage	1967 Edition	1963 Edition
NONE		NUL	NULL	2-5-6-8		2	
1-8		SOH	SOM	1-2-5-6		3	
2-8		STX	EOA	3-5-6-8		4	
1-2		ETX	EOM	1-3-5-6		5	
3-8		EOT		2-3-5-6		6	
1-3	WRU	ENQ	WRU	1-2-3-5-6-8		7	
2-3		ACK	RU	4-5-6-8		8	
1-2-3-8	BELL	BEL	BELL	1-4-5-6		9	
4-8		BS	FE _o	2-4-5-6		:	
1-4	TAB	HT	HT/SK	1-2-4-5-6-8		:	
2-4	LINE FEED	LF		3-4-5-6		<	
1-2-4-8		VT	VTAB	1-3-4-5-6-8		=	
3-4		FF		2-3-4-5-6-8		>	
1-3-4-8		CR		1-2-3-4-5-6		?	
2-3-4-8		SO		7-8		⊙	
1-2-3-4		SI		1-7		A	
5-8		DLE	DC _o	2-7		B	
1-5	XON	DC1		1-2-7-8		C	
2-5	TAPE	DC2		3-7		D	
1-2-5-8	XOFF	DC3		1-3-7-8		E	
3-5	TAPE	DC4	DC4 (STOP)	2-3-7-8		F	
1-3-5-8		NAK	ERR	1-2-3-7		G	
2-3-5-8		SYN	SYNC	4-7		H	
1-2-3-5		ETB	LEM	1-4-7-8		I	
4-5		CAN	S _o	2-4-7-8		J	
1-4-5-8		EM	S ₁	1-2-4-7		K	
2-4-5-8		SUB	S ₂	3-4-7-8		L	
1-2-4-5		ESC	S ₃	1-3-4-7		M	
3-4-5-8		FS	S ₄	2-3-4-7		N	
1-3-4-5		GS	S ₅	1-2-3-4-7-8		O	
2-3-4-5		RS	S ₆	5-7		P	
1-2-3-4-5-8		US	S ₇	1-5-7-8		Q	
6-8		SP	b	2-5-7-8		R	
1-6		!		1-2-5-7		S	
2-6		"		3-5-7-8		T	
1-2-6-8		#		1-3-5-7		U	
3-6		\$		2-3-5-7		V	
1-3-6-8		%		1-2-3-5-7-8		W	
2-3-6-8		&		4-5-7-8		X	
1-2-3-6		'		1-4-5-7		Y	
4-6		(2-4-5-7		Z	
1-4-6-8)		1-2-4-5-7-8		[
2-4-6-8		*		3-4-5-7		\	
1-2-4-6		+		1-3-4-5-7-8]	
3-4-6-8		,		2-3-4-5-7-8		^	↑
1-3-4-6		-		1-2-3-4-5-7		~	←
2-3-4-6		.		1-2-4-5-6-7		⋮	
1-2-3-4-6-8		/		3-4-5-6-7-8		⋮	
5-6		0		1-3-4-5-6-7		⋮	ACK
1-5-6-8		1		2-3-4-5-6-7		⋮	ALT.MODE
				1-2-3-4-5-6-7-8	RUB OUT DELETE		ESC

Note 1: Remove tine — marking. Leave tine — spacing.

Note 2: Blank space indicates same as 1967 edition.

Note 3: Codes shown are for even parity operation; for nonparity, remove eighth level tine.

Figure 3 - Answer-Back Drum Coding

4.10 Do not remove the character suppression tine from the last row of each segment of the answer-back drum (row no. 20 for answer-back drums coded for one-cycle operation) on sets used in systems where a response to each answer-back activation signal must be obtained. The last row can be coded with any other character that is compatible with the particular system.

4.11 The number of rows available for message coding is shown below for 1-, 2-, or 3-cycle operation:

CYCLE OPERATION	TOTAL ROWS	AVAILABLE ROWS
1	21	20
2	10 (11)*	9 (10)*
3	7	6

*Alternately one, then the other.

4.12 The number of rows available for actual station identification is less than shown above, because each coded message should begin and end with CARRIAGE RETURN and LINE FEED (this may be altered in specific applications). This assures that the transmitted message will appear at the beginning of a line of the receiving teletypewriter set and eliminates overprinting.

Note: Another use which can be made of the character suppression level tines is the elimination of coding errors. If a coding error is made, or for some reason it is necessary to suppress (erase) characters from the code drum, remove the character suppression tine from the rows affected.

CODING EXAMPLES

4.13 In switched network service applications, the station identification for 1-cycle operation may not exceed 14 characters, including spaces. The answer-back drum should be coded as follows:

ABBREVIATION

ACK
CR
LF
RO
SP
SUP

KEY TO ABBREVIATION

Acknowledge
Carriage Return
Line Feed
Rub Out
Space
Character Suppression

(a) Example 1:

SUP CR LF RO

TELETYPE SP NILES CR LF ACK

Company City

Station Identification
(Maximum – 14 characters)

Note: In this system, the ACK character code combination must be the final significant character code combination in the coded answer-back message.

(b) Example 2:

SUP CR LF RO

ERIE SP BOST CR LF ACK SUP SUP SUP SUP
SUP

Company City

Station Identification
(Less than maximum
number of characters)

Note: If the station identification is less than the maximum of 14 characters in length, then the remaining rows on the answer-back drum must be coded with the character suppression code according to Example 2 above.

4.14 To replace the answer-back drum, place the TP180854 brace in its detented open position, and lift feed pawl (do not overextend its spring). Replace drum with its shaft firmly seated in the contact block slots. Release feed pawl and TP180854 brace. Rotate answer-back drum to assure proper seating of its associated parts. Check that the contact wires are located in their proper slots.

28 AND 35 ANSWER-BACK UNIT (LABD)

LUBRICATION

CONTENTS	PAGE	
1. GENERAL.	1	of oil to each motor bearing every 1500 hours of continuous operating time or every six months, whichever occurs first.
2. BASIC UNITS.	2	1.06 The unit should be thoroughly lubricated, but overlubrication, which might allow oil to drop or grease to be thrown on other parts should be avoided. The following general instructions supplement the specific lubrication points indicated:
Drive gears.	2	
Drum feed mechanism.	4	
Main shaft.	3	
Motor.	2	
1. GENERAL		
1.01 This section is reissued to provide instructions for lubricating the 5- and 8-level answer-back unit. Since this revision is of a general nature, marginal arrows have been omitted.		(a) Apply one drop of oil to all spring hooks, except those used on electrical contacts, and the nine distributor block contact (wire contacts) tension springs.
1.02 The general lubrication areas are illustrated by photographs. The specific points to receive lubricant are indicated on line drawings with appropriate textual instructions. Line drawings and textual instructions follow each photograph and are keyed to the photograph by paragraph numbers.		(b) Apply oil to all pivot points, except the stop armature pivot area.
1.03 The answer-back unit should be lubricated just before placing it in service. After a few weeks of service, relubricate to make certain that all points receive lubrication.		(c) Do not lubricate the distributor brushes and disc surface.
1.04 Thereafter, the answer-back unit should be lubricated after a service period of 1500 hours or 6 months, whichever occurs first.		1.07 Exercise special care to prevent oil or grease from getting between the armature and pole piece of the clutch trip magnet. Keep all electrical contacts free from oil or grease.
1.05 Use standard KS7470 oil and KS7471 grease at all locations where the use of oil or grease is indicated. Apply 20 to 25 drops		1.08 Specific lubrication requirements and the amount of lubricant are indicated at each lubrication point in accordance with the following code:
		O1 Apply 1 drop of oil.
		O2 Apply 2 drops of oil.
		O3 Apply 3 drops of oil.
		G Apply thin film of grease.
		SAT Saturate (felt oilers, washers, wicks) with oil.

2. BASIC UNITS

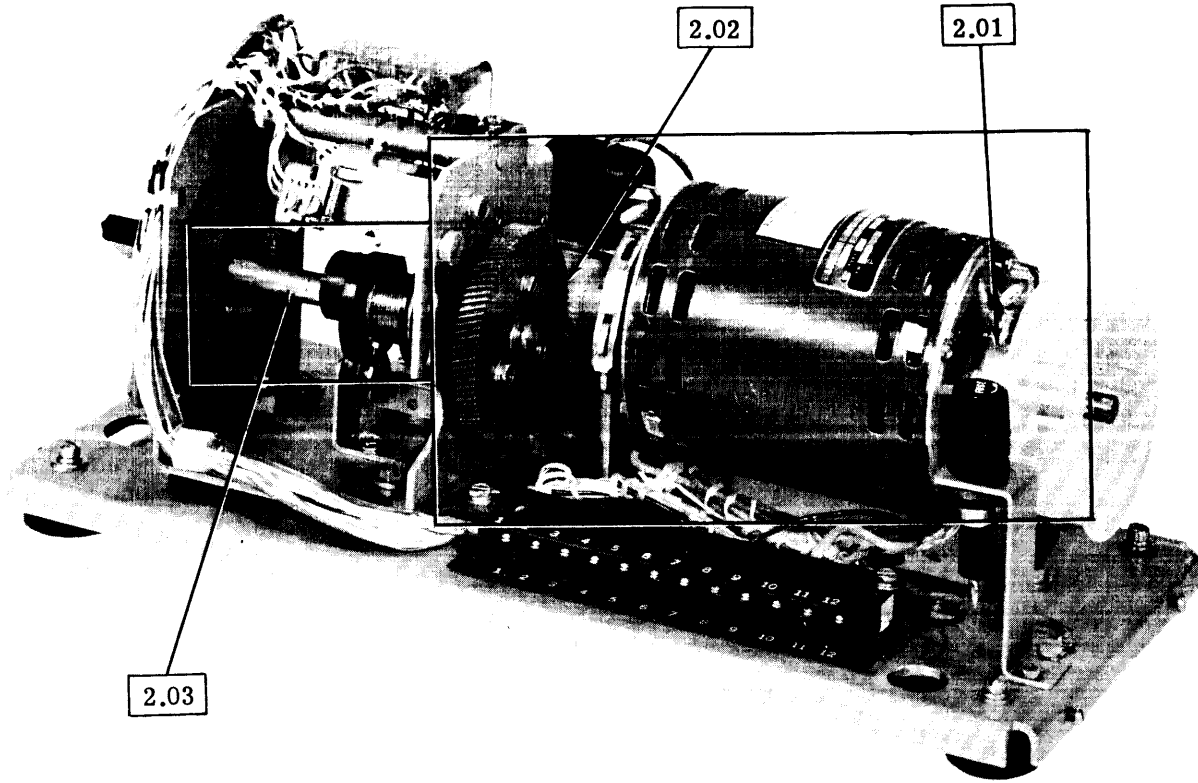

2.01 Motor (Lubricate every 1500 hours of continuous operating time or every six months, whichever occurs first).

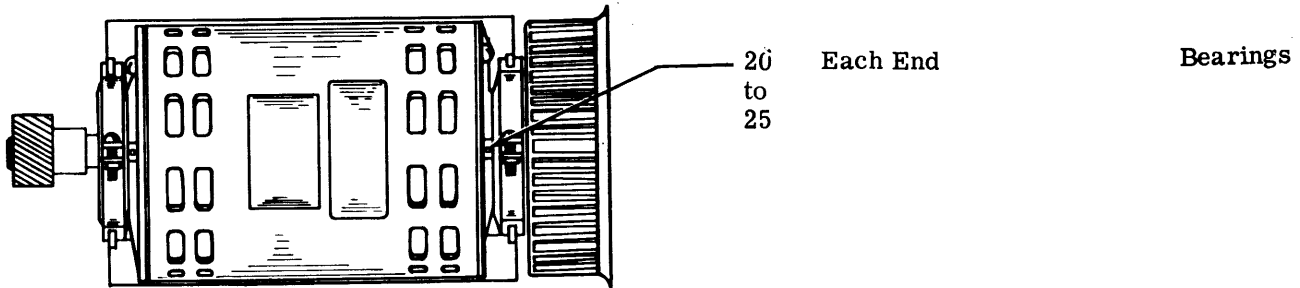

2.02 Drive Gears

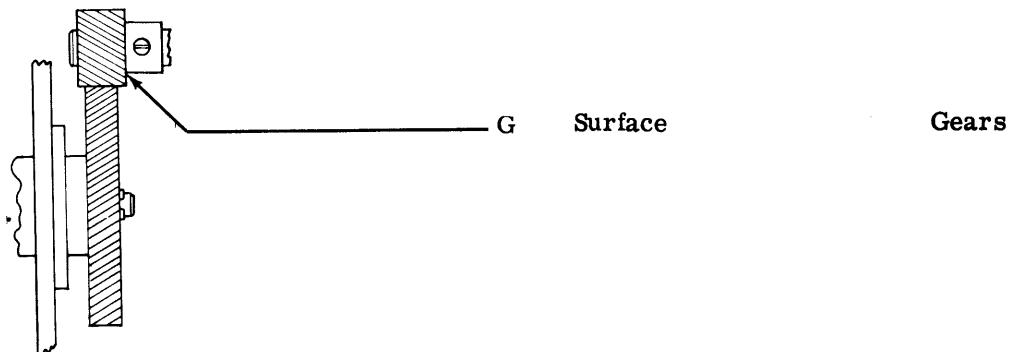

2.03 Main Shaft

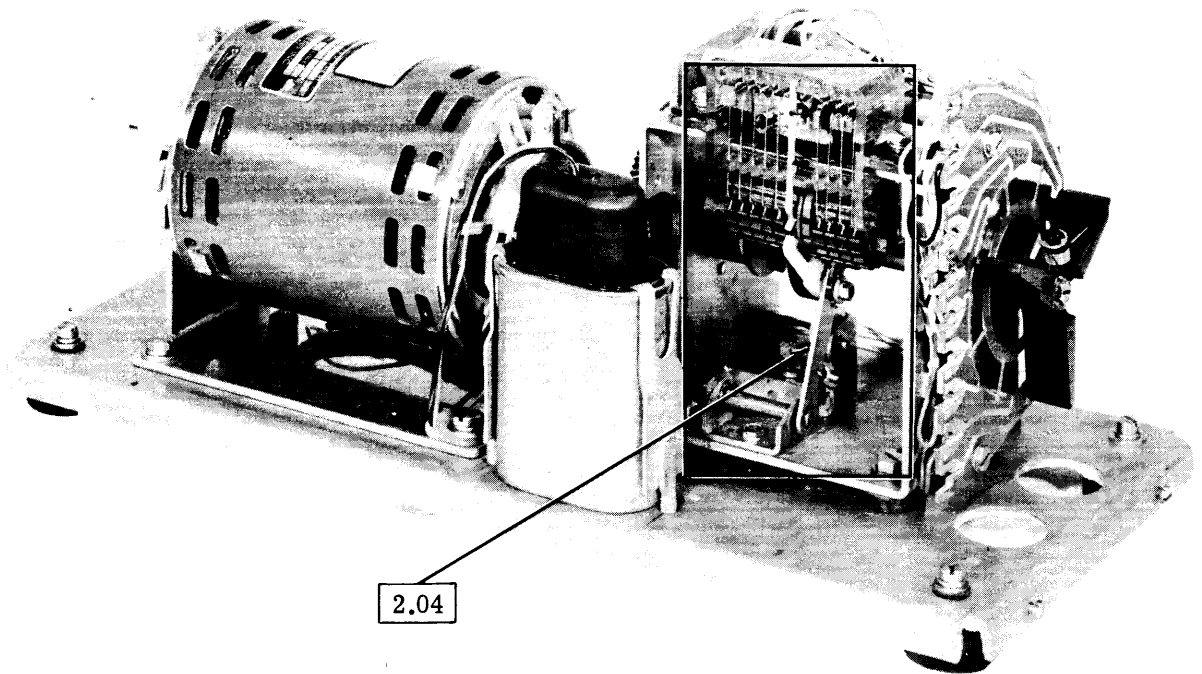
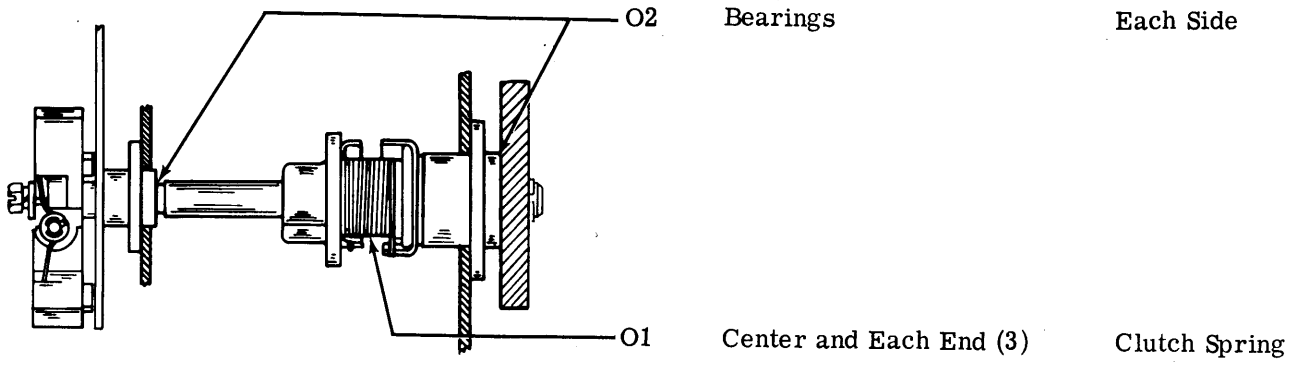

SECTION 574-235-701TC

2.04 Drum Feed Mechanism

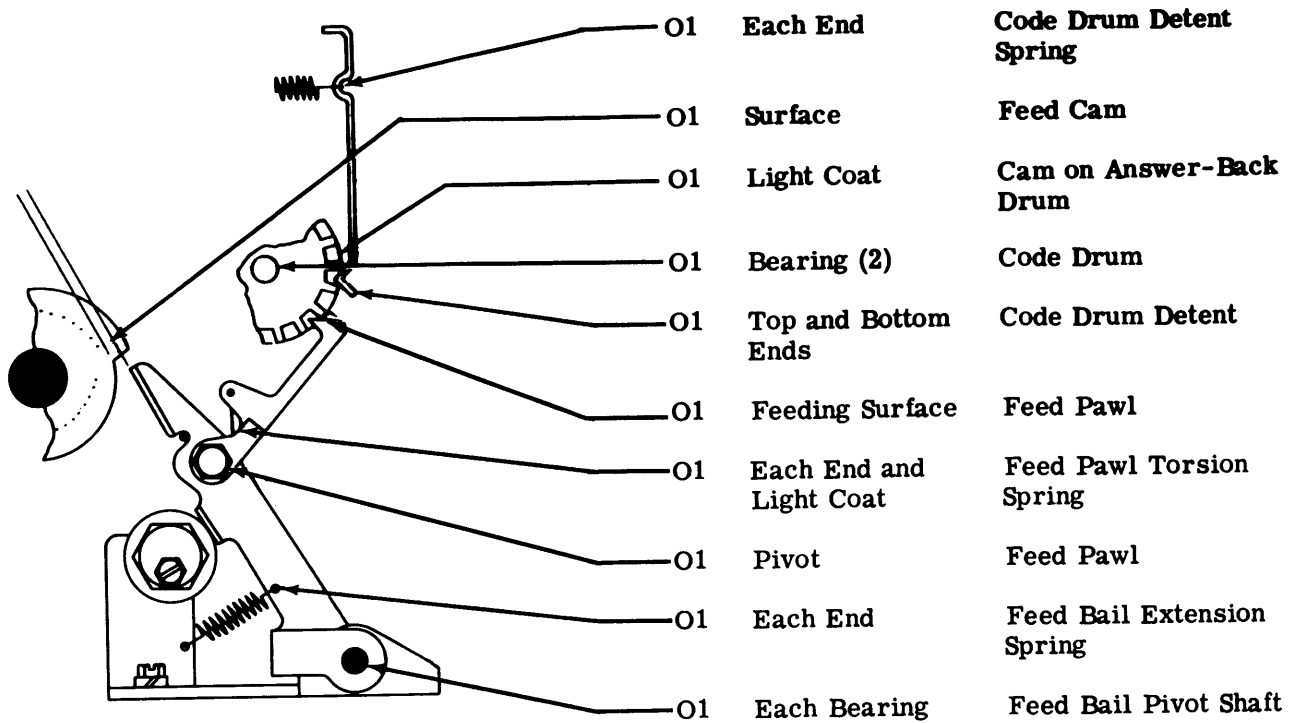

28 AND 35 ANSWER-BACK UNIT
DISASSEMBLY AND REASSEMBLY

CONTENTS	PAGE
1. GENERAL	1
2. DISASSEMBLY AND REASSEMBLY ..	1
COVER AND TERMINAL BLOCK ...	1
MOTOR AND MOTOR MOUNTING BRACKET	2
FUSE HOLDER AND BRACKET	2
CAPACITOR	2
CODE DRUM	2
CONTACT BLOCK	2
ANSWER-BACK MECHANISM	3
MAIN SHAFT	3

1. GENERAL

1.01 Disassembly, as outlined in this section, covers a procedure for removing the principle components which make up the answer-back unit.

1.02 The technician should refer to the exploded views found in the appropriate parts literature for an illustration of the unit to be disassembled, for location and visual identification of parts, and detailed disassembly and reassembly features.

1.03 Most maintenance, lubrication, and adjustments can be accomplished simply by removing the subject component from the unit. If possible, disassembly should be confined to components, which can, in some cases, be removed without disturbing adjustments. When reassembling the components, be sure to check all associated adjustments, clearances, and spring tensions.

1.04 Retaining rings (Tru-arcs) are made of spring steel and have a tendency to release suddenly when being removed. Loss of these retainers can be minimized as follows: Hold the retainer by hand to prevent it from rotating. Place the blade of a suitable screwdriver in the slot of the retainer. Rotate the

screwdriver in a direction to increase the diameter of the retainer for removal.

1.05 Avoid loss of springs in disassembly by holding one spring loop by hand while gently removing the opposite loop with a spring hook. Do not stretch or distort springs in removing them.

1.06 References made from left to right, up or down, and front or rear apply to the answer-back unit as viewed from the side with the answer-back mechanism to the left and the motor to the right.

2. DISASSEMBLY AND REASSEMBLY

2.01 In removing a component from the unit, the procedure followed and the location from which parts are removed must be carefully noted so that reassembly can be done correctly. Where no specific instructions are given for reassembly, reverse the procedure used in removing it.

COVER AND TERMINAL BLOCK

2.02 To remove the TP194792 cover and TP111289 terminal block, the following procedure should be used:

- (a) Loosen the four cover fastening screws and remove cover from base plate.
- (b) Remove the flat washers, lockwashers, and screws which secure the upper insulator to the terminal block. Remove upper insulator.
- (c) Remove the power and control cable spade type terminal lugs from under the screws on the terminal block.
- (d) Remove the studs, terminal block, and lower insulator from the base plate.

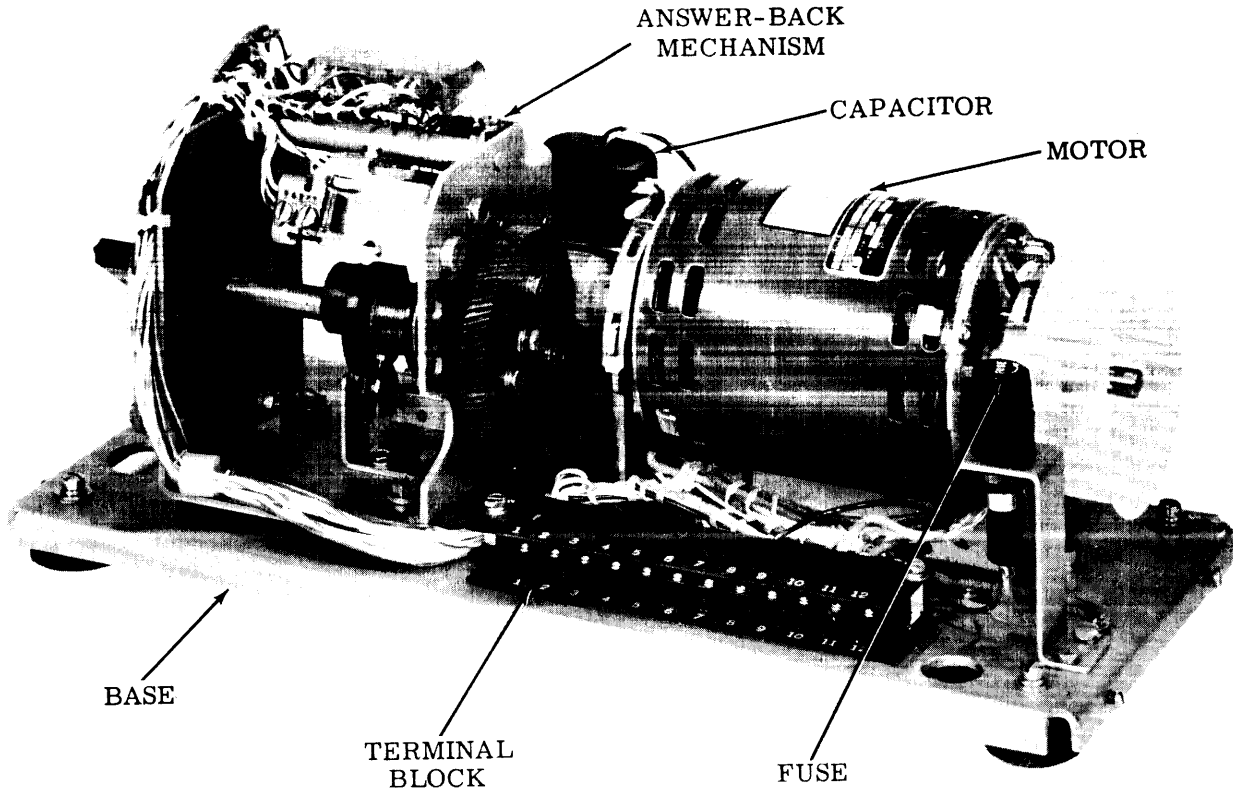

Figure 1 - Answer-Back Unit

MOTOR AND MOTOR MOUNTING BRACKET

2.03 Remove the TP192120 motor and TP192238 motor mounting bracket as follows:

- (a) Remove the two TP151620 motor mounting straps from each end of motor. Lift motor from mounting bracket.
- (b) Remove the four screws which secure motor mounting bracket. Lift bracket from base plate.

FUSE HOLDER AND BRACKET

2.04 Remove the TP116783 fuse holder and TP194814 fuse-holder bracket as follows:

- (a) Remove the nut from lower end of fuse holder, and lift from fuse-holder bracket.
- (b) Remove the two screws which secure fuse-holder bracket. Lift bracket from base plate.

CAPACITOR

2.05 To remove the TP192019 capacitor, remove the brackets from each side of capacitor and lift from base plate.

CODE DRUM

2.06 Remove the TP180827 code drum as follows:

- (a) Lift the answer-back brace by means of its extension, to deflect all contact wires and the detent away from the code drum.
- (b) Hold the feed pawl away and slip the code drum out. Do not overextend the feed pawl spring.

CONTACT BLOCK

2.07 To remove the TP180823 contact block, remove the screws, lockwashers, flat washers and spacers securing each side of the block and lift from bracket.

ANSWER-BACK MECHANISM AND BRACKET

2.08 Remove the three mounting screws from the TP194782 bracket and lift bracket and mechanism from base plate.

MAIN SHAFT

2.09 To remove the TP194784 main shaft from the answer-back mechanism proceed as follows:

- (a) Remove the brush holder mounting screw, flat washer, and lockwasher. Remove the brush holder.
- (b) Remove the three distributor disc mounting screws, flat washers, and lockwashers. Remove distributor.

(c) Remove the three mounting screws, flat washers, and lockwashers from the drive gear.

(d) Remove retaining ring, drive gear, and clutch sleeve by pulling over end of main shaft.

(e) Remove the mounting screws, flat washers, and lockwashers from each bearing on the main shaft and remove each bearing.

(f) Rotate main shaft until the flat portion of the motor hold cam is adjacent to the feed bail. Withdraw the shaft to the left until the right gear end clears the bracket. Slide shaft out from beneath the trip magnet.