

Teletype Corporation
R & D Organization

This Material is not intended for distribution outside the Teletype Corporation. If it becomes necessary to send copies outside the Teletype Corporation, Sections I and IV shall be removed and approvals obtained per Section 6.2 of R & D Routine 33.

Specification 60,324S
August 8, 1962

ENGINEERING SPECIFICATION FOR EQUIPMENT
COMPRISING THE TELETYPE AUTOMATIC
SWITCHING PACKAGE (TASP)

TABLE OF CONTENTS

<u>Section</u>	<u>Total Pages in Section</u>
I. General Description and Engineering Requirements	8
II. Detailed Description and Theory of Operation	58
III. Adjustments, Special Requirements and Lubrication	30
IV. Manufacturing Instructions	1
V. Installation and Servicing Instructions	16

ENGINEERING SPECIFICATION FOR EQUIPMENT
COMPRISING THE TELETYPE AUTOMATIC
SWITCHING PACKAGE (TASP)

SECTION I

GENERAL DESCRIPTION AND ENGINEERING REQUIREMENTS

1. GENERAL DESCRIPTION

a. This equipment shall be employed to provide a switching package to accommodate 20 half-duplex multi-station line circuits.

- (1) Switching information shall normally originate from printer keyboards at the outlying stations operating at 60 W.P.M. All idle line circuits shall be placed in a marking condition (normally 0.060 amperes) to prevent machines from running open.
- (2) In the event that the line seeking and connecting portion of the switching package is idle, a line break signal shall be recognized as a bid for a path through the switching package from any line circuit.
- (3) When the selector portion of the switching package is thus connected to the line of the outlying station making a call, an answer back of "GA" shall be transmitted from the switching package. If the switching package is busy establishing another circuit connection, the outlying station will not receive a "GA".
- (4) Upon receipt of "GA", the calling station will transmit the call directing code of the line circuit desired. If the desired circuit is idle, the switching package shall momentarily break the line of that circuit, transmit a second "GA" to the calling station, and connect the called circuit to the calling circuit.
- (5) Upon receipt of the second "GA", the calling station will transmit the "end of address" code (CR LF) which shall disconnect the selector portion of the switching package from the calling circuit. The switching package is now available for processing the next circuit request. (If the outlying stations are equipped for selective calling, the specific station call directing code is transmitted prior to the "end of address" code).
- (6) If the called circuit is busy or in a disabled condition, the switching package shall transmit an answer back of "LTRS B Z" followed by a line break to the calling circuit. The line break shall result in an automatic disconnection of the calling circuit from the selector portion of the switching package.

If an invalid circuit call directing code is received from the calling circuit, no answer-back shall be transmitted by the switching package.

- (7) Following transmission of the "end of address" code (CR LF), the message text will be transmitted by the calling station and, if desired, answered or acknowledged by the called station. Upon message completion, a second line break signal transmitted by either the calling or called station shall be recognized by the switching package to disconnect the two circuits.
- (8) Transmission from one station to another on the same circuit shall be accomplished in a similar manner except that the call directing code of the circuit involved is requested of the switching package. The switching package shall again respond with a "GA" answer back which assures the calling station that the line circuit shall be reported busy to the rest of the network. As before, another line break signal following message completion shall release the circuit to accept calls from other circuits.
- (9) To establish a group call, the operation shall proceed as previously described to the point where the selector portion of the switching package has been connected to the line of the calling station as indicated by the reception of the first "GA" answer-back from the switching package. The calling station will then transmit the code characters "FIGS Z" informing the switching package that a group call is in process. In response, the switching package shall again transmit the two character "GA" answer-back to the calling station where it is recorded in the upper print case condition (usually &-). The calling station will then transmit a LTRS character to return the calling printer to the lower case position followed by the call directing codes of the line circuits desired, waiting for an answer-back after each request.

If the desired circuit is idle, the switching package shall momentarily break the line of that circuit, transmit a "GA" answer-back to the calling circuit.

If the called circuit is busy or disabled, the switching package shall transmit a "LTRS B Z" answer-back to the calling station. In this case, the line break disconnecting signal shall be withheld. Following transmission of the "end of address" code (CR LF) by the calling station, transmission may proceed on a conference basis among the selected groups. A second line break signal transmitted from any station shall disconnect the entire group.

- (10) Selective emergency calls shall be made from only one line circuit located in the immediate area of the switching package. This shall be the No. 1 line circuit and shall be designated "Headquarters" (SPHQ).

To establish a selective emergency call, the headquarters operator shall first select the circuits desired by operating circuit selection keys on the manual switch panel associated with the switching package. This panel is connected to the switching package by means of a 25-ft. cable and should normally be located adjacent to the headquarter's printer.

The operator shall then have the option of either seizing the selector portion of the switching package immediately or waiting until the last circuit selection has been completed. By placing a select NORMAL-HOLD key in the hold position, the operator shall eliminate contention from other line circuits for the selector portion of the switching package. However, he must still wait until any previous circuit selection has been completed. The fact that circuit selection is in process shall be indicated by appropriate lamps on the manual switch panel.

If the emergency call is extremely urgent, the operator shall disconnect any line circuit from the selector portion of the switching package by momentarily depressing a select RELEASE pushbutton.

After observing that circuit selection has been terminated, the headquarter's operator shall transmit a line break signal, and in return, receive a "GA" answer-back from the switching package. The operator will then transmit the "emergency call" code (FIGS G) which shall cause the switching package to (1) momentarily break the line of all circuits previously selected and also those to which they may be already connected, (2) disconnect all busy circuit connections whether wholly or partially desired by the headquarter's station, (3) transmit a second "GA" answer-back to headquarters where it is received in the upper print case condition, and (4) connect all selected circuits to the headquarter's circuit.

Following the receipt of the second "GA", which is recorded in the upper case print condition (usually &-), the headquarter's operator will transmit a LTRS character to return his printer to the lower case position followed by the "end of address" code (CR LF) which shall disconnect the headquarter's circuit from the selector portion of the switching package. However, before the switching package can recognize another bid for a circuit connection, the select NORMAL-HOLD key must be returned to the NORMAL position.

The emergency message text will now be transmitted by the headquarter's station and, if desired, answered or acknowledged by the called stations. Upon message completion, a second line break signal transmitted by either headquarters or any called station shall be recognized by the switching package to disconnect all circuits.

- (11) To prevent any one line circuit from being indefinitely connected to the selector portion of the switching package, as would be the case if the "end of address" code (CR LF) were not transmitted by the calling station, a time delay device shall be provided to limit this connection to approximately two minutes.
- (12) Terminal wiring facilities shall be provided for the following:
- (a) Modification to permit line circuits to be used in sequentially selected groups and assigned a single call directing code for the group. Under this arrangement, a busy condition shall be encountered only when all circuits in the group are busy or disabled.
 - (b) Modifications to permit a change in the circuit disconnect code from the normal second line break signal to an "upper case blank H" code signal. In this event, Model 28 monitor printers located in the immediate area of the switching package will be employed for the necessary code recognition. This change must be accompanied by a modification in the "busy" indicating answer-back code from the normal "LTRS B Z" to "LTRS B Z LTRS FIGS BL H" and an associated change in the switching package circuit selector (LS) by which it is controlled. The selective emergency call procedure will be varied accordingly.
 - (c) Modifications to permit local RT set control on certain desired line circuits. These terminal facilities shall operate in conjunction with other control equipment associated with each RT set which will be employed as a future adjunct to the switching package.
- (13) "Circuit" and "line" jacks shall be provided for manually divorcing a line circuit from the switching package and connecting it directly into the desired line circuit.
- (14) The -40V, +48V and +120V DC power for the switching package shall be furnished by two power supplies which are connected to a fuse panel for distribution to the associated circuits. The -40V and +48V DC rectifiers are contained within the same power supply unit. In the event a fuse blows, a FUSE ALARM lamp shall be lighted. The failure of both power supplies shall be indicated by the lighting of an AC FAIL lamp. The failure of a particular rectifier shall be indicated by the lighting of the corresponding power alarm lamp. In addition, all of the preceding power failures shall result in the lighting of a CAB ALM lamp and the sounding of a buzzer alarm. The operation of a non-locking type key shall silence the buzzer.

- (15) An auxiliary circuit control panel shall be incorporated within the switching package to indicate (1) which line circuit is connected to the selector portion of the switching package and, therefore, in the SELECT condition, (2) which line circuits are in a BUSY condition, (3) which circuits are in an OPEN LINE condition and (4) which line circuits have been DISABLED as a result of line difficulties external to the switching package. A locking type key shall result in all calls to a disabled line receiving a busy answer-back response.
- (16) The switching package equipment shall be designed to mount on 23 inch mounting racks and arranged for housing in two-7-foot apparatus cabinets on customer premises.
- (17) The switching package shall incorporate as many Bell System standard components as is practical.

2. ENGINEERING REQUIREMENTS

- a. The switching package shall be designed to connect any one of 20 line circuits by use of a two character call directing code to any other circuit in the network on (1) a single call basis or (2) group call on a conference circuit basis.
- b. The necessary equipment and circuit controls shall be of the modular design for individual installation or rapid substitution when required. To provide for systems having less than 20 circuits, the individual line circuit controls shall be packaged in groups of two per mounting arrangement.
- c. When the line seeking and connecting portion of the switching package is in an idle condition, a line break signal shall be recognized as a bid for a path through the switching package from any line circuit.
- d. The switching package shall provide for the transmission of a "GA" answer-back code to the calling station to indicate that (1) the calling circuit has been connected to the selector portion of the switching package or that (2) the called circuit has been connected to the calling circuit or that (3) the switching package has acknowledged the receipt of a "FIGS Z" code signal which will be transmitted by the calling station prior to a group call.
- e. If the called circuit is in an idle condition, the switching package shall momentarily "break" the line of that circuit, transmit the "GA" answer-back code to the calling station and simultaneously connect the called circuit to the calling circuit.
- f. To indicate that the called circuit is busy or in a disabled condition, the switching package shall normally provide for the transmission of a "LTRS B Z" answer-back code to the calling station.

- g. On single circuit calls wherein the called circuit is busy or in a disabled condition, the calling circuit shall be automatically disconnected from the switching package. This shall normally be accomplished by the transmission of a second line break signal from the switching package.
- h. The selector portion of the switching package shall be disconnected from the calling station upon the receipt of the "end of address" code (CR LF) or the "end of message" code which shall normally be a second line break signal.
- i. An established connection between two or more line circuits shall be released upon the receipt of the "end of message" code which shall normally be a second "line break" signal.
- j. On group calls involving two or more called circuits, the calling station will first transmit a "FIGS Z" code signal prior to the usual two character circuit call directing codes. In response to the "FIGS Z" code signal, the switching package shall transmit the two character "GA" answer-back to the calling station. Thereafter, on calls to busy or disabled circuits, the "line break" disconnecting signal shall be withheld.
- k. To prevent any one line circuit from being indefinitely connected to the selector portion of the switching package, a time delay device shall be incorporated to limit this connection to approximately two minutes. This device shall be provided with an ON-OFF switch and shall also be capable of time delay settings of approximately 100, 80, 60 or 40 seconds by means of a wiring change. Variations of + 15 seconds shall be maintained at each setting.
- l. Emergency priority calling facilities shall be provided at the central office for connection to all selected circuits. The central office shall be connected to the No. 1 line circuit and shall be designated "Headquarters" or (SPHQ).
- m. A manual switch panel shall provide the headquarter's operator with a means for selecting those line circuits to be included in the emergency call. The fact that a line circuit is busy or is connected to the selector portion of the switching package shall be indicated by appropriate lamps. This panel shall be connected to the switching package by a 25-foot cable and should normally be located adjacent to the headquarter's typing unit.
- n. The headquarter's operator shall have the option of either seizing the selector portion of the switching package immediately or waiting until the last circuit selection has been completed.

- o. Terminal wiring facilities shall be provided for the following:
- (1) Future modifications to permit line circuits to be used in sequentially selected groups and assigned a single call directing code for the group. A busy condition shall be encountered only when all circuits in the group are busy or in a disabled condition.
 - (2) Future modifications to permit a change in the circuit disconnect code from the normal second line break signal to an "upper case blank "H" code signal. Model 28 monitor printers located in the immediate area of the switching package will be employed for the necessary code recognition. This change shall be accompanied by a modification in the "busy" indicating answer-back code from the normal "LTRS B Z" to "LTRS B Z LTRS FIGS BL H" and an associated change in the switching package circuit selector (LS) by which it is controlled. This change shall also necessitate a variation in the selective emergency call procedure.
 - (3) Future modifications to permit local RT set control on certain line circuits. These terminals facilities shall operate in conjunction with auxiliary control equipment associated with each RT set which will be employed as a future adjunct to the switching package.
- p. Switching jacks shall be provided for manual line circuit connection in case of breakdown.
- q. Fuses and alarms shall be provided for the necessary power supplies.
- r. The switching package control circuits and signal line circuits shall obtain local battery from self-contained power supplies and shall be operable thereby from a 103 to 127 volt, single phase, 15 ampere alternating current power source with a frequency of 60 cycles \pm 0.5 for the synchronous Model 28 selector (LS) and answer-back motor.
- s. The line circuits shall have a nominal voltage of 120 volts DC with 0.060 ampere neutral signals. This voltage shall be maintained within the range of 115 to 130 volts. Ripple components shall not exceed 1%. Excluding the line adjustment rheostat, the total resistance of the equipment connected to the signal line within the switching package shall not exceed 1200 ohms. Under conditions of negligible external line resistance, the line current shall be capable of adjustment within the limits of 0.055 and 0.095 amperes. Irrespective of line conditions, no more than 0.120 amperes shall flow in the signal line.

- t. The mechanical equipment within the switching package shall consist of a Model 28 selector (LS) unit, a Model 28 distributor for "GA" answer-back transmission, and a Model 28 answer-back mechanism for "LTRS B Z" transmission. This equipment shall normally operate at 60 WPM on 7.42 baudot telegraphic code.
- u. The switching package equipment shall be designed to mount on 23 inch mounting racks and arranged for housing in two 7-foot apparatus cabinets on customer premises.
- v. The switching package shall incorporate as many Bell System Standard components as is practical.

SECTION II

DETAILED DESCRIPTION AND THEORY OF OPERATION

1. DETAILED DESCRIPTION

- a. The switching package equipment is mounted on 23 inch panels which are housed in two 7-foot apparatus cabinets on the customer's premises. These cabinets are open in the front for mounting covers and equipment panels. The back of the cabinets are full length doors for complete access from the rear. They also have cable access openings in the top and bottom.
- (1) The 165801 cabinet houses the rectifier power supplies, the cross-bar switches, a shelf and cover assembly containing the Model 28 selector unit and other related equipment, the answer-back control panel, the power distribution relay panel, the fuse and alarm panel, the power distribution panel and the associated wiring. A power cord is included with this cabinet and is part of the power distribution panel. The power is run from the distribution panel to an outlet strip on the inside of this cabinet. The power supplies and other apparatus are plugged into this strip. Extra outlets are available for future expansion or for other uses.
 - (2) The 165802 cabinet houses the open line disable panel, the line circuit panels, the common control relay panel, the terminal and connector panel and the associated wiring. The incoming leads from the associated line circuits are brought into this cabinet. This cabinet and the other one are interconnected by three cables, one for power (P), one for circuit selection (S), and one for control connections (C). There is one line circuit panel mounted in this cabinet for every two line circuits in the system.
- b. The +120V, +48V and -40V DC power for the switching package is furnished by two power supplies which are located in the 165801 cabinet. These power supplies are connected to the 165933 fuse and alarm panel for distribution to the associated circuits.
- (1) The REC56 rectifier assembly is the +120 V.D.C. supply and is located at the bottom of the cabinet. Its input is 117 V.A.C. at 60 cycles and its output is 115V to 130V D.C. at 5 amperes. This power supply is a semiconductor type and has automatic regulation. It has a self-contained input fuse of 10 ampere. Its output is fused by the 165933 fuse and alarm panel.
 - (2) The REC55 rectifier assembly contains both the -40 and +48 volt supplies, and is located directly above the +120 V.D.C. supply. The input to this assembly is 117 V.A.C. at 60 cycles. The +48 V.D.C. supply will furnish 8 amperes, and the -40 V.D.C. supply will furnish 3 amperes. Both are a semiconductor type of supply with automatic regulation. It has a self-contained input fuse of 10 amperes. Its output is fused by the 165933 fuse and alarm panel.

(3) Power Source Requirements:

Input Voltage	- 115 Volts A.C. \pm 10%
Phase	- Single
Frequency	- 60 CPS \pm 0.5 CPS for synchronous motor
Input Current at 115 Volts A.C.	- Approx. 8.7 amperes
Power Factor at 115 Volts A.C.	- Approx. 0.96
Wattage at 115 Volts A.C.	- Approx. 936 watts

- c. The Model 28 Sequence Selector, LS3, is housed in the 165804 shelf and cover assembly and is located just above the two power supply assemblies. Included with the LS3 is its base LSB2, which has the "BZ" answer-back mechanism mounted on it, and also the Model 28 distributor LD14 which includes the "GA" answer-back mechanism. Mounted on the LS3 Sequence Selector is the stunt box assembly and the 165928 universal contact modification kit. This equipment is the actual selecting apparatus, the stunt box recognizing the various call directing codes and then opening or closing contacts as required. Therefore, the stunt box arrangement determines the character sequences which are the circuit call directing codes. Any two character sequence may be used providing the first character is the same in all instances. The usual arrangement is as follows:

<u>Circuit No.</u>	<u>Call Directing Code</u>
1	XA
2	XB
3	XC
4	XD
5	XE
6	XF
7	XG
8	XH
9	XI
10	XJ
11	XK
12	XL
13	XM
14	XN
15	XO
16	XP
17	XQ
18	XR
19	XS
20	XT

The stunt box is also used to distinguish various other codes, such as the "BZ" answer-back, the FIGS G, CR LF, and FIGS Z codes and so on. The Sequential Selector is driven by an LMU3 motor.

- d. The 165803 cross-bar switch assembly is used to do the actual circuit cross connecting. For the twenty-line circuits possible in TASP, four cross-bar switch assemblies are required. Each cross-bar switch includes 10 selecting magnets (SM) and 10 holding magnets (HM). The SM magnets operate first when TASP is seized by a calling circuit. The HM magnets operate after TASP has been seized and the associated HM magnet for the line being called is operated and "holds" the circuit connection. This magnet "holds" even after the SM magnet has been released to free TASP for further circuit requests. The cross bar switch is wired to a 130 pin, male type connector. When the cross-bar switch is mounted, this connector is plugged into a connector strip in the cabinet.
- e. The 165954 Line Circuit Panels are mounted in the 165802 cabinet. They are 6 inches high and 23 inches wide and mount the relays and other equipment for two lines. The cabinet will handle 10 panels at most, or 20 line circuits. They are mounted between two channels starting with lines 1 and 2 at the top of the channels and lines 19 and 20 at the bottom of the cabinet. Each line is independently wired and each has its own cable and connector. Each line has the following relays associated with it. Each panel has a break recognition relay (BRC), an incoming line relay (LA), an outgoing line relay (LB), an outgoing line relay control relay (LBC), and an open line lamp control relay (OLC). The BG is the break generating relay and the BR1, BR2 and BR3 relays are break recognition relays. Also on the panel is the select relay (S), the select control relay (SC), the line connecting relay (X) and the line selecting relay (SR).

On the back of the panel is a line jack and rheostat used for measuring and adjusting the line current for each circuit. Also located at the rear of the panel is the electronic driver assembly 165870, which is used to operate the outgoing line relay LB.

- f. Contained in both cabinets are various panel assemblies. Each has a distinct function and none are duplicated.
- (1) The 165963 answer-back control panel is located in the 165801 cabinet just below the cross-bar switches. It contains the busy control relay (BZ), the busy break generating relays No. 1 and 2 (BZBG1 & 2), and the sequence selector line relay (LS) and its driver (D).
 - (2) The 165986 power distribution panel is located on the front of the 165801 cabinet at the very top. It has the TASP system power ON-OFF switch and indicator lamp. This lamp is lighted only when the power cord is plugged into a voltage source and the TASP system switch is in the OFF position. Also on this panel is a red light which, when lighted, indicates a general cabinet alarm.

- (3) The 165967 power distribution relay panel is located directly behind the power distribution panel in the 165801 cabinet. This panel contains the fuse alarm relays FA1 & 2, the rectifier failure relays RF1, 2 and 3 and the buzzer suppression relay BR. Also mounted on this panel are the 1C, 1P and 1S connectors, to which the inter-cabinet cables are connected.
- (4) The 165933 fuse and alarm panel is located on the front of the 165801 cabinet. This panel contains the holders and fuses for the -40, +48 and +120 volt supplies for each line circuit. There are common fuses for the three circuit control panels which consist of the open line disable panel, the common control relay panel and the manual switch panel. The answer-back control panel, the cross-bar switches, the fuse alarm circuit and the rectifier failure alarm circuit are also fused. The buzzer suppression non-locking key and the 120 volt failure, the 48 volt failure, the 40 volt failure, the A.C. failure and fuse alarm lamps are also located on this panel.

When a fuse or power supply fails, the appropriate lamp is lighted and the buzzer comes on. A momentary closing of the buzzer suppression key turns off the buzzer. The fuses are an indicating type, so that when one fails a portion of the fusing element protrudes from the cap of the fuse holder.

- (5) The 165807 open line disable panel is mounted on the front of the 165802 cabinet. This panel contains the NORMAL-DISABLE line circuit keys. This key is kept in the NORMAL position usually and is only operated when a line circuit is disabled. It also has four rows of lamps (20 in each row) that indicate four separate conditions of the line circuits. The top row has red lenses and indicate that a particular line has selected TASP. Only one red lamp can light at any one time. The first row is labeled SELECT. The second row is labeled BUSY and has a white lens. This lamp lights as soon as a line selects TASP or as soon as it connects to or is connected to another line circuit. Only one or even all of these lamps may be lighted at one time. The third row of lamps is clear in color and is labeled OPEN LINE. Whenever the current fails in the associated line circuit this lamp lights and indicates that the NORMAL-DISABLE key associated with the line circuit in trouble should be operated. When this key is operated it removes that line circuit from TASP so that the switching package will transmit a "BZ" answer-back to any circuit calling it. When the key is operated the associated lamp (amber color) in the fourth row is lighted. This last row is labeled DISABLED.

- (6) The 165959 common control relay panel is located immediately above the line circuit panel for the number 1 and 2 lines in the 165802 cabinet. This panel contains certain of the relays that perform functions in common with all the line circuits. These include the emergency call break generating relays (BG1, 2, 3 and 4), the emergency call relays (EC1 and 2), the universal connecting relay (UCR) and the answer-back control relay (ABQ). Also included is the select timing control relay (ST) and its associated select timing control tube (T). This timing circuit is used to automatically remove a line circuit connected to the selector portion of the switching package after approximately two minutes.
- (7) The 165808 terminal board and connector panel is located at the top of the 165802 cabinet. It is accessible from the rear of the cabinet. The 2C, 2P and 2S connectors are on this panel to which the inter-cabinet cables are connected. The AP connector is on this panel also, to which the cable for the 165985 manual switch panel is connected.

Circuit and line jacks are provided on this panel for manually divorcing a line circuit from the switching package and connecting it directly to a desired line circuit.

Included on this panel are 19 terminal strips with 20 terminals each. Several of these strips are utilized in the present design, but several are connected internally only for possible future uses. These strips are listed below, the first three being at the top of the panel and in a horizontal position with the last 16 strips being vertical and listed as viewed from the back, left to right.

- (a) The uppermost is labeled "GND" and the ground lead of the line is attached here. Internally it goes to terminal 4 of the CJ-1 to 20 jacks.
- (b) The next is labeled "+" and the high side of the line is attached here. Internally it goes to terminal 1 of the LJ-1 to 20 jacks.
- (c) The next is labeled "MON PTR" and is not attached to anything, externally or internally. It is available for future use in case a monitor printer is ever added to a line.
- (d) The first vertical strip, on the extreme left, is the LS strip. It is connected internally to the N.O. contacts XA through XT in the 28 Type Sequence Selector. Externally terminals 1 to 20 are jumpered to terminals 1 to 20 of the SR strip.

57

- (e) Next is the SR strip. Externally it is jumpered to the LS strip (see above). Internally it goes to the upper terminal U of the SR relay.
- (f) Next is the ST strip. Internally all of the terminals are strapped together. Externally terminals 2 to 20 are jumpered to terminals 2 to 20 of the SC strip. ST-1 is connected to SC-1 through the normally closed contacts (2,3) of the HQNH key.
- (g) Next is the SC strip. Internally it is connected to the SC relay as part of its operating circuit. Externally it is connected to the ST strip (see above). It also has its No. 1 terminal tied through the 2 AUX toggle switch and normally closed (6) contacts of the S relays to common battery.
- (h) Next is the XH strip. Internally it is connected to the upper terminal U of the X relay by means of its normally open contacts(2) to function as an auxiliary holding circuit. Externally it is available for future use.
- (i) The LDA, LDB and LDC strips are next and internally are connected to the normally open (12), common (11) and normally closed (10) contacts, respectively, of the Normal-Disable (ND-1) to 20 keys. Externally they are all available for future use.
- (j) The BLA, BLB and BLC strips are next and internally are connected to the normally open (8), common (8), and normally closed (8) contacts, respectively, of the X relay. Externally they are all available for future use.
- (k) Next is the RTA strip. Internally all terminals are strapped together and connected to the pins U13 and A13 in the 2 AUX connector and to terminal 20 of the NORMAL-DISABLE ND-1 to 20 keys and then through the normally closed contacts (9) of the X relays to the RTB terminal strip.
- (l) Next is the RTB strip. Internally it is connected to the normally closed contact (9) of the X relay (see above). Externally it is available for future use.
- (m) Next is the RTC strip. Internally it is connected to the 2RT terminal in the line panels. Externally it is available for future use.
- (n) Next is the MPD strip. Externally its terminals 1 to 20 are jumpered to the APD strip, terminals 1 to 20. Internally it is connected to the 2DS terminal, the COMMON contact (A) of the BRC relay and to the normally open contact (2) of the BR3 relay, all located on the line circuit panel.

- (o) Next is the APD strip and it is the one on the extreme right. Externally it is jumpered to the MPD strip (see above). Internally APD-1 connects to the No. 1 cross-bar switch and to the HQBR key. APD-2 to 20 connect to the Normal-Call NC-2 to 20 keys.
- g. The 165985 manual switch panel is a separate panel and may be located remotely from the cabinets. It contains BUSY and SELECT lamps and NORMAL-CALL locking keys for each of the line circuits in the system (up to 20 lines). It also has a non-locking BUSY-RELEASE key and a non-locking SELECT-RELEASE key. These last two keys, along with the locking type NORMAL-HOLD key on this panel, are used for selective emergency calling.

This panel is equipped with a 25 foot cable and connector to connect with the 165802 cabinet.
- h. In addition to the aforementioned equipment there are three cable assemblies used to inter-connect the cabinets. There is also an input power cord assembly.
 - (1) The 165877 cord assembly (P) has the inter-cabinet power connections. It is a 108 conductor cable approximately seven feet long which allows the cabinets to be mounted two feet apart.
 - (2) The 165878 cord assembly (C) is the inter-cabinet control cable. It is a 132 conductor cable approximately seven feet long. This cable is used to connect the cross-bar switches to the line circuit panels and has the inter-line connections.
 - (3) The 165879 cable assembly (S) is a 24 conductor seven feet long inter-cabinet cable. This cable contains the conductors between the line circuit panels and the Model 28 type sequence selector.
 - (4) The 165828 cable assembly is the power input cord and is part of the 165986 power distribution panel assembly. It is approximately 20 feet in length.
- i. For initial installation and after prolonged shutdown and disassembly, the following items should be checked before assembling and starting the equipment.
 - (1) In the 165801 cabinet the following items should be checked:
 - (a) All connectors should be seated properly and firmly, care being taken while inserting them not to cock or twist them and thus break or bend the pins. The power cord should be plugged into a suitable power source. Make sure the internal end of the power cord is securely inserted. The rectifiers and sequence selector's power cords should be plugged into the cabinets internal

power strip. Three cables are connected to the 28 Type Sequence Selector. The following are the connector designations located in this cabinet: PAL, PAR, 1P, 1C, 1AUX, 1S, PL, 2AXB, 1AXB, 2XB, 1XB, AB, LD, LS and LSB. All have mating connectors except the 1AUX.

- (b) There are two toggle switches in this cabinet and both are accessible from the front of the cabinet. One is on the 165963 answer-back control panel. This switch is labeled 10 CIRCUITS and 20 CIRCUITS and should be in the corresponding position. The other switch is the power ON-OFF switch located on the front of the cabinet at the top.
 - (c) On the 165963 panel there is an opening for one RY30 line relay (LS). This relay is to be adjusted before it is mounted on the panel. Instructions for adjusting this relay are in Section III, Part 2 of this specification.
 - (d) The 165803 cross-bar switch assemblies are mounted in this cabinet. Their connectors should be properly engaged, care being taken to put the proper connector in its proper place.
 - (e) Before using this equipment all lamps and fuses should be inserted in their proper places. Most of fuses and lamps are on the front of the cabinet, however, the rectifiers' fuses are at the rear, near the bottom of the cabinet.
- (2) In the 165802 cabinet the following items should be checked.
- (a) All connectors should be properly inserted. The connector designations in this cabinet are 2P, 2C, 2AUX, 2S, AP, CP1, CP2, LC1, LC2, LC3 and LP1 through LP20. All have mating connectors except the 2AUX and LP's for absent line circuit panels. Make certain that all incoming lines are connected to their proper terminals. (Refer to Section II, 1.f.(7)(a) and (b)).
 - (b) All the locking type NORMAL-DISABLE keys should be in the NORMAL position. The 2 AUX. toggle switch should be in the "OFF" position as long as no auxiliary equipment is connected to the cabinet. The toggle switch on the common control relay panel should be in the "ON" position. This switch is in the timing circuit and must be in the "ON" position to "unshort" the timing capacitor. There are 20 other toggle switches in this cabinet, one for each line circuit. When the line is connected to the cabinet and a line circuit panel is mounted and its connector inserted in its appropriate outlet, the associated toggle switch should be in the "ON" position. With no line circuit panel mounted, the associated toggle switch should be in the "OFF" position.

This toggle switch is a double pole single throw type switch and has one set of contacts in the timing circuit and one set of contacts in the operating circuit of the SC relay. However, these contacts are only to be used when the line circuit panel is not used or temporarily removed from the circuit.

- (c) There is an electron tube (T) in the timing circuit located on the common control relay panel. Make sure this tube is seated properly.
 - (d) There are two RY30 type of line relays for each line circuit. One is the incoming line relay (LA) and one is the outgoing line relay (LB). Each is to be adjusted in accordance with the special adjustment instructions found in Section III of this specification. These relays (LA and LB) are identical, and after they are adjusted they are interchangeable in the circuit. These relays are mounted in the line circuit panels from the front of the cabinet.
 - (e) There is also a break recognition relay (BRC) in each line circuit which requires special adjustments in accordance with Section III of this specification.
 - (f) There are four rows of lamps (20 in each row) on the front of the cabinet. Make sure each lamp and its associated lens are seated properly in their socket.
 - (g) The line circuit panels are obtained as needed, one for each two lines in the system. These are mounted in the cabinet so that the connectors are installed in the proper LP connectors which correspond to the signal lines to be controlled. (LP1 is associated with line 1, LP2 with line 2, etc.) If the selective emergency calling feature is to be utilized one line circuit panel must be mounted so that one of its connectors may be placed in the LP1 connector. This feature is only associated with the number one line circuit.
- (3) If the 165985 manual switch panel is used, the following items should be checked:
- (a) This panel is basically a replica of the upper half of the 165807 open line disable panel with an added feature. That is, it has 20 lamps indicating which circuit is in the select condition and 20 lamps indicating which circuits are busy. The added feature is the 19 NORMAL-CALL locking type keys used for selective emergency calling. The station on the number one line circuit which has this panel (usually the headquarter's station) is able to make selective emergency calls. Signal line circuits having their associated NORMAL-CALL keys in the call position will be included in the emergency call.
 - (b) There are two rows of lamps (20 in each row) on the front of the panel. Make sure each lamp and its associated lens are seated properly in their socket.

- j. Refer to the following engineering specifications for detailed description and theory of operation of the individual units not herewith included:

<u>SPEC. NO.</u>		<u>UNITS</u>
6442S	LS3/ADJ	Sequence Selector/Stunt Box for the Normal Second Line Break Disconnect
6442S	LS3/ADK	Sequence Selector/Stunt Box for the Special Upper Case, Blank, H Disconnect (Special Requirement for Future Use)
60,178S	165928	Universal Contacts for Sequence Selector
60,179S	LSB2	Sequence Selector Base with LTRS B Z Answer-Back
60,179S	LSB3	Sequence Selector Base with LTRS B Z LTRS FIGS BL H Answer-Back (Special Requirement for Future Use)
60,322S	LD14	Distributor with GA Answer-Back
9549S	REC55	48 & 40 Volt Rectifier
9550S	REC56	120 Volt Rectifier
60,321S	165870	Electronic Driver for Line Relay
Bell System Practices Plant Series Sec. 030-720-701	165803	Cross-Bar Switch Assembly (Western Electric 324L)
Bell System Practices Reference Data Bulletin X-75509	AF-, AG-, AJ-	Wire Spring Relays
60,395S	193646	Modification Kit: To Convert Model 28 Selective Calling Page Printer Set with Stunt Box Arrangement "AFQ" for Use with TASP at 60 WPM Only

- k. This section describes a typical system utilizing TASP control. It should be noted that the operating procedure is largely determined by the type of outlying station equipment used in the network and, therefore, may vary considerably.

SYSTEM USING THE NORMAL SECOND LINE BREAK SIGNAL AS THE CIRCUIT DISCONNECTING CODE.

To improve the overall efficiency of the system and to avoid inadvertent circuit disconnections, each outlying station should be equipped with a 193646 Modification Kit. This kit converts a Model 28 selective calling page printer set with stunt box arrangement "AFQ" for use with TASP at 60 WPM only. In addition, the line break signal should not be initiated more often than once every 15 seconds.

A motor stop mechanism is not normally employed at an outlying station of this system. However, if this feature is considered necessary, the time delay motor stop mechanism should be used. It should be arranged to re-start the motor immediately upon a line break signal without waiting for the reclosing of the line. A calling operator should re-start his motor by a quick "jab" of the LINE BREAK key before attempting to contact TASP as described later.

SYSTEM USING THE SPECIAL UPPER CASE BLANK H SIGNAL AS THE CIRCUIT DISCONNECTING CODE.

This system does not require the use of a 193646 Modification Kit on an outlying station. A time delay motor stop arrangement or an upper case blank H initiated motor stop mechanism may be employed. It also should be arranged to re-start the motor immediately upon a line break signal without waiting for the reclosing of the line. Refer to Section III, 2.d. for further information. Outlying stations without selective calling may be arranged to unshift on upper case H to provide for the lower case printing of the first "GA" from TASP.

Described herein is a simplified version of a typical communication network featuring selective calling equipment, and it is anticipated that an operating procedure similar to the following will be employed. As previously described, two-character call letters are assigned to each circuit, resulting in XA, XB, XC, etc. for our example. Each circuit, in turn, may have any number of stations such as AA, AB, AC, etc. on circuit XA, or BA, BB, BC, etc. on circuit XB and so on.

(1) Single Circuit Call

- (a) To Contact TASP - Before any messages can be transmitted, either to the caller's own circuit or to another, TASP should be contacted. By going through TASP the circuit or circuits communicating will appear busy to the rest of the network.

The calling operator (say, AC) depresses the LINE BREAK key on his Model 28 page printer set for approximately 3 seconds. This actuates his printer and other printers on the XA circuit, placing them in the select non-print condition. At the same time, an automatic search is made to connect circuit XA to TASP. Upon completion of the line break signal and if TASP is available for circuit switching, the calling operator receives a "GA" (go ahead) answer-back as indicated by means of a signal light on his printer which is operated by appropriate stunt box contacts. If TASP is busy, a "GA" will not be forthcoming, indicating he should try again in a few minutes. After receipt of a "GA" answer-back, the operator transmits his own station's call letters, AC, to place his machine in a printing condition.

- (b) To Call Stations on the Same Circuit - To call stations on his own circuit, the calling operator transmits his own circuit's call letters, in this case, "XA". TASP then returns another, page printed "GA". Thereafter, circuit XA will be reported busy to the rest of the network. The operator then transmits each desired station's call letters (AA, AB, etc.) and the end of address code (CR, LF) to place all stations on circuit XA in a non-select condition and to release TASP for further switching. Selected stations on circuit XA are now ready for transmission to one another.
- (c) End of Message - Upon message completion, an end of message code is transmitted from either the sending or receiving station to release the circuit to accept calls from other circuits. The end of message code is normally a second line break signal which is transmitted by depressing the LINE BREAK key for approximately three seconds.

(2) A Two-Circuit Call

To call another circuit after the first "GA" answer-back from TASP, the operator transmits his own station calling code, such as "AC", to first place his printer in a printing condition, followed by the call letters of the other circuit (say, XB). If the desired circuit is idle, the switching package momentarily breaks the line of that circuit, transmits a second "GA" to the calling circuit, and connects the called circuit to the calling circuit. The operator then places the desired stations on the called circuit in a printing condition by transmitting the proper station calling codes (BA, BB, etc.), followed by the end of address code (CR LF), and the message text. The end of message code is then transmitted by either the calling or a called station to disconnect the two circuits.

If the operator attempts to call a circuit which is busy, TASP will send back a code combination (LTRS BZ LINE BREAK), disconnecting the calling circuit from TASP. The operator on the circuit will then have to wait a few minutes before again starting the procedure over.

(3) A Group Call

A call to a number of circuits involves procedures similar to those used for calling one circuit. After receiving the initial "GA" from TASP and placing his printer in a printing condition, the calling operator transmits a prefix code (FIGS Z). This code is inserted to prevent TASP from automatically disconnecting the calling station circuit if one of the other called circuits is busy. In response, the switching package transmits another "GA" to the calling circuit where it is recorded in the upper case print condition (usually &-). The operator then transmits a LTRS character and the call letters of the first circuit desired. If the called circuit is available, a connection is made and TASP transmits "GA" to the calling operator. To place the desired stations on the called circuit in a printing condition he sends the appropriate station calling codes.

The operator follows this procedure until desired circuits are connected. He then transmits the end of address code (CR LF) to release TASP for further switching, and transmission may proceed on a conference basis among the selected group. An end of message code (second line break) transmitted from any station disconnects the entire group.

(4) Selective Emergency Call From Headquarters

The headquarter's station on line circuit No. 1 is equipped with a special applique panel used to call in any or all circuits for an emergency message. By observing indicator lamps on his applique unit the operator can determine which, if any, line circuit is connected to the selector portions of the switching package and also which line circuits are in a busy condition. The emergency call then proceeds as follows:

- (a) The operator places the number one circuit NORMAL-HOLD key on the applique unit in the HOLD position. This prevents any line circuit except No. 1 from seizing the selector portion of the switching package.
- (b) The operator then presets the NORMAL-CALL switches on his applique unit to the CALL position, one for each circuit he wishes to receive the message.
- (c) In order to preserve the normal flow of traffic, the usual procedure would then require the headquarter's operator to wait until the selector portion of the switching package and ALL desired line circuits are idle before he attempts to seize TASP.
- (d) If the emergency call is extremely urgent and another circuit is already connected to the selector portion of the switching package, the operator may disconnect that circuit from TASP by depressing the SELECT RELEASE key on the applique unit until the associated SELECT lamp is extinguished.
- (e) Again, if the emergency call is extremely urgent and the No. 1 line circuit is busy receiving a group called message, the operator may disconnect the No. 1 line circuit from the group by depressing the number one circuit BUSY RELEASE key on the applique unit until the No. 1 circuit BUSY lamp is extinguished. If the operator wishes to disconnect the complete group of circuits of which he is a part, he initiates an end of message signal (normally a second line break).
- (f) Emergency calls that must be made before all the desired line circuits are idle should, if possible, include all busy circuits whether desired or not. In this way all interrupted circuits are positively alerted that an emergency call is in process and that their previous circuit connection must be re-established. This procedure need not be followed if it is definitely known that those busy circuits which are desired are not connected to those which are not desired.

- (g) The headquarter's operator then depresses the LINE BREAK key of his send-receive page printer for approximately three seconds. Upon release of the LINE BREAK key, the operator will receive a "GA" answer-back which operates the yellow light on his printer.
- (h) The operator then returns the NORMAL-HOLD key to the NORMAL position and transmits his station's call letters to place his printer in a printing condition.
- (i) The operator transmits the code sequence "FIGS G" to actuate all called circuits. In response, the switching package momentarily breaks the line of all circuits previously selected and also those to which they may be already connected, disconnects all busy circuits connections whether wholly or partially desired by the headquarter's station, transmits a second "GA" answer-back to headquarters where it is received in the upper print case condition, and connects all selected circuits to the headquarter's circuit.
- (j) The headquarter's operator then transmits a LTRS character and places the stations on the called circuits in a printing condition by transmitting a universal station calling code, followed by the end of address code (CR LF) and the message text.
- (k) Upon message completion, the end of message code may be transmitted by either the headquarter's operator or by any called circuit operator. As before, this is normally a second line break signal which is transmitted by depressing the LINE BREAK key of the page printer for approximately three seconds.

(5) Automatic Disconnect From Selector Portion of TASP

In the event the calling operator inadvertently neglects to send the end of address code (CR LF), the switching package will disconnect him automatically by means of a time delay circuit. This releases TASP for further circuit switching approximately two minutes after the calling operator receives his first "GA" answer-back. Obviously, it is advantageous to have the station operator manually keyboard the end of address code since the time delay mechanism will hold the calling circuit in the selector portion of TASP longer than if it were disconnected manually.

2. THEORY OF OPERATION

- a. The following relay operating sequence may be observed to occur during the transmission of a message from one line circuit to another. (Refer to the sequence charts and schematic wiring diagram 4451WD).
 - (1) With the signal line circuits connected to the switching package, the initial application of power to the switching package results in the operating condition of the following components:

Line Circuit Panels: (LP)

4451WD
Location

R25 BRC - Break recognition control relay energized.
Q27 LA - Incoming line relay energized to marking condition.
P27 LB - Outgoing line relay energized to marking condition
by virtue of its electronic driver D.
Q26 LBC - Outgoing line relay control relay energized.
P26 OLC - Open line lamp control relay energized.
N27 BR1 - Break recognition relay No. 1 energized.
M26 BR2 - " " " No. 2 de-energized.
M27 BR3 - " " " No. 3 de-energized.
L26 SC - Select control relay de-energized.
K26 S - Select relay de-energized.
K27 SR - Line selecting relay de-energized.
K26 BG - Break generating relay energized.
H26 X - Line connecting relay de-energized.

Common Control Relay Panel: (CCRP)

4451WD
Location

H22 ABC - Answer-back control relay energized.
D20&D19 EC1 and EC2 - Emergency call relay de-energized.
E23 BG1 - Emergency call break generating relay No. 1
de-energized.
E22 BG2 - Emergency call break generating relay No. 2
energized.
E21 BG3 - Emergency call break generating relay No. 3
energized.

E20 BG4 - Emergency call break generating relay No. 4 energized.
D18 UCR - Universal Connecting relay de-energized
D22 T - Select timing control tube de-energized
D23 ST - " " " relay de-energized

Answer-Back Control Panel: (ABCP)

D6 LS - Sequence selector line relay energized to marking condition by virtue of its electronic driver D.
K7 BZ - Busy control relay de-energized.
H6 BZBG1 - Busy break generating relay No. 1 energized.
J16 BZBG2 - " " " " No. 2 de-energized.

Cross Bar Switches:

K19&K15 SM'S - Selecting magnets de-energized
F19&F15 HM'S - Holding magnets de-energized

(2) Signal Line Circuit

The No. 1 signal line circuit may be traced from the common battery (Q24) return of the power distribution circuit at the power connector 1P-C1 to C15 through the inter-cabinet power cable to connector 2P-C1 to C15, the normally closed contacts (3,4) of the CJ-1 circuit jack, the No. 1 ground (Q21) terminal, out to the signal line itself and back to the switching package at the No. 1 + battery (R21) terminal through the normally closed contacts (2,3) of the LJ-1 line jack, the normally closed contacts (1,2) of the CJ-1 circuit jack, the No. 1 line circuit panel LP connector at LP1-A, the winding of the BRC relay, the normally closed contacts (2,3) of the LJ line circuit panel line jack, the L ADJ line current adjusting rheostat, the marking (R26) contacts (4,1) of the LB line relay, the operating winding of the LA line relay, the LA1 resistor to +120 volt battery through the No. 1 LP connector at LP1-DD (D26), the inter-cabinet power cable connectors at 2P-R2 and 1P-R2 to +120 volt battery of the power distribution circuit.

(3) Internal Line Circuit

- (a) The No. 1 internal line circuit may be traced from the common (C23) battery return of the power distribution circuit at the power connector 1P-A3 to A15 through the inter-cabinet power cable to connector 2P-A3 to A15, the No. 1 line circuit panel ground terminal, the No. 1 line circuit panel LP connector at LP1-HH, the spacing contacts (1,5) (Q26) of the LA line relay, the normally open contacts (12,13) of the LBC relay, the No. 1 LP connector at LP1-Y (N28), the common control relay panel (CCRP) connector at CP1-B8, the normally closed contacts (2) of the BG1 relay or the normally closed contacts (10) of the BG3 relay, the CCRP connector at CP1-A3, the open line disable panel CCOLP connector at LC2-D2, the normally closed contacts (2,1) of the ND-1 (Q31) normal-disable control switch, the CCOLP connector at LC2-A3 (R29), the No. 1 LP connector at LP1-X to terminal R of the electronic driver D which operates the LB (P27) line relay.
- (b) The power input to the electronic driver D (P27) may be traced from the -40 volt battery (C23) from the power distribution circuit at the power connector 1P-E1 through the inter-cabinet power cable to connector 2P-E1, the No. 1 LP connector at LP1-FF (C26), through the D1 resistor (P27) to terminal B and through the D resistor (R27) to terminal A of the driver. Common battery return is applied to terminal L. Under these conditions the operating winding of the LB line relay is energized and its marking contacts (4,1) (R26) in the signal line circuit are held closed. With a common battery return potential applied to terminal R of the driver, the driver output is cut off and the operating winding of the LB line is de-energized causing its marking contacts (4,1) to open and its spacing contact (1,5) to close.
- (c) The LBC high speed relay by virtue of its normally open contacts (12,13) (P25) prevents the telegraphic signals transmitted by a station on the No. 1 signal line circuit from being reflected to the circuit's own receive relay LB and, consequently, from being reverted to the loop of the sending station. The LA line relay transfers its LA contacts in the same rhythm as the sending station transmitting contacts. The LA contacts cause the LBC relay to operate at the same rhythm thus preventing any space polarity pulse from reaching the driver and through it the LB line relay. It may also be observed that while the signal line circuits are operating on a neutral basis, the internal line circuits are operating on an inverse neutral basis.

(4) Interconnection of Signal Line Circuits

- (a) Any particular internal line circuit is connected to other internal lines by means of cross bar switches. For example, the No. 1 internal line spacing contacts (Q26) of the LA line relay are connected to the horizontal contact points of the associated cross bar switches through the No. 1 line circuit panel LP connector at LP1-C, the inter-cabinet control cable connectors at 2C-S1 and 1C-S1 (P14), and the No. 1 and No. 1A cross bar switch connectors at 1XB-S1 (F10) and 1AXB-S1 (F12), respectively. The spacing contacts of the LA line relay are also connected to the vertical points of the associated cross bar switches through the normally open contacts (12) (Q25) of the X relay, the No. 1 LP connector at LP1-B, the inter-cabinet control cable connectors at 2C-P1 and 1C-P1 (Q14) and the No. 1 and No. 2 cross bar switch connectors at 1XB-P1 (J9) and 2XB-P1 (P9), respectively.
- (b) Since all other internal line circuits are similarly connected to their associated cross bar switches, a parallel connection of any particular internal line circuits may readily be made by the proper operation of the selecting SM (horizontal contacts) and holding HM (vertical contacts) magnet of the switches. In any network of internal line circuits thus established, only the LBC relay associated with the sending signal line will respond to the rhythm of the transmitting contacts and prevent its electronic driver and through it its LB line relay from responding to the telegraphic signals. However, the space polarity pulses generated on the sending line are reflected to all other electronic drivers of LB line relays which are connected to the internal line of the sending circuit. Since the marking contacts (4,1) of the LB line relays are in the signal line circuits, the transmitted signals are hereby relayed in the form of interruptions of the intended receiving station loop. The spacing contacts (1,5) (R26) of the LB line relays hold the associated LA line relays in the marking condition, thereby preventing these outgoing signals from being reflected back into the internal line circuits.

(5) "Line Break" Signal Recognition for Path Through Switching Package (Refer to Sequence Chart No. 1)

- (a) The "line break" signal recognition is controlled by the BRC relay (R25) which has its winding located in the signal line circuit. With the No. 1 signal line circuit in an idle (marking) condition, the operating circuit of the BR1 (N27) break recognition relay No. 1 may be traced from the common battery return (C14) of the power distribution circuit at the power connector 1P-C1 to C15 through the inter-cabinet power cable to connector 2P-C1 to C15, the manual switch panel CCMSP connector at AP-U13 (C16), the normally closed contacts (2,3) of the non-locking headquarter's busy release key HQBR (H42),

the CCMSp connector at AP-K2, the applique disconnect terminal strip at terminal APD-1, the monitor printer disconnect terminal strip at terminal MPD-1, the No. 1 line circuit panel LP connector at LP1-u (M28), the normally open contacts (A,D), now closed, of the BRC relay, the normally closed contacts (3), of the X relay, to the upper terminal U of the BR1 relay, and from the lower terminal L of the relay to +48 volt battery through the No. 1 LP connector at LP1-EE (D26) the inter-cabinet power cable connectors at 2P-M2 and 1P-M2 to +48 volt battery of the power distribution circuit.

- (b) A "line break" signal will remove the battery from the BRC relay and cause its marking contacts (A,D) (N27) to open and its spacing contacts (A,C) (N26) to close. The operating circuit of the BR2 break recognition relay No. 2 may then be traced from the common battery return at the normally closed contacts (A,C) (N26) of the BRC (R25) relay, the normally open contacts (2) (M26), still closed, of the BR1 relay, the normally closed contacts (9) of the S select relay, the normally closed contacts (5) of the X line connecting relay, to the upper terminal U of the BR2 relay, and from the lower terminal L of the relay to +48 volt battery. The holding circuit of the BR2 relay (M26) may then be traced from the common battery return at the normally closed contacts (A,C) of the BRC relay, the normally open contacts (2), now closed, of the BR2 relay, the normally closed contacts (5) of the X relay to the upper terminal U of the BR2 relay.
- (c) The operation of the BR2 relay completes the operating circuit of the BR3 (M27) break recognition relay No. 3. Its operating circuit may be traced from the common battery return at the normally open contacts (10) (M27), now closed, of the BR2 relay, the normally open contacts (4), still closed, of the BR1 relay, to the upper terminal U of the BR3 relay, and from the lower terminal L of the relay to +48 volt battery. The holding circuit of the BR3 relay may then be traced from the common battery return at the normally open contacts (4), now closed, of the BR2 relay, the normally open contacts (4), now closed of the BR3 relay to the upper terminal U of the BR3 relay.
- (d) If the "line break" signal is at least of 1/2 second duration, the slow-release BR1 relay will restore to its un-operated position. The operating circuit of the SC (L26) select control relay may then be traced from the common battery return of the power distribution circuit to the power connector 1P-A3 to A15 through the inter-cabinet power cable to connector 2P-A3 to A15, the No. 20 line circuit panel ground terminal, the No. 20 line circuit panel LP connector at LP20-T (S30), the normally closed contacts (6) of its S select relay, the No. 20 LP connector at LP20-U, and similarly through each even numbered line circuit panel until at LP2-U it may be traced to the No. 19 LP connector at LP19-T (S33), the normally closed contacts (6) of its S relay, the No. 19 LP connector at LP19-U and similarly through each odd numbered line circuit panel to the ON-OFF switch (R36) associated with the 2 AUX connector, the select control terminal strip at terminal SC-1 (M37), the No. 1 LP connector at LP1-j (L28), the normally closed

contacts (5) (L27) of the BR1 relay, the normally open contacts (6), now closed, of the BR2 relay, the normally open contacts (6), now closed, of the BR3 relay, the normally closed contacts (7) of the X relay, the SC diode, to the upper terminal U of the SC relay, and from the lower terminal L of the relay to the No. 1 LP connector at LP1-Z, the open line disable panel CCOLP connector at LC1-A3, the normally closed contacts (4,5) of the locking NORMAL-DISABLE key ND-1 (L30), the CCOLP connector at LC1-T2, the common control relay panel CCRP connector at CP1-T2, the normally closed contacts (6) (L32) of the ST select timing control relay, the SC resistor to +120 volt battery through the CCRP connector at CP1-U7 (G14), the inter-cabinet power cable connectors at 2P-T12 and 1P-T12 to +120 volt battery of the power distribution circuit.

- (e) The SC resistor (L32) limits the total current to all SC relays and, therefore, prevents more than one SC relay from operating at any one time.
- (f) The holding circuit of the SC relay may then be traced from the common battery return in the manual switch panel CCMSP (L18) to the normally closed contacts (2,3) of the non-locking headquarter's SELECT-RELEASE key HQSR, the CCMSP connector at AP-K4, the inter-cabinet control cable connectors at 2C-N13 and 1C-N13, the answer-back control panel ABCP connector at AB-H, the 28 type selector unit connector at S-24, the normally closed momentary CARRIAGE RETURN LINE FEED sequence contacts, the selector unit connector at S-25, the ABCP connector at AB-J (L23) the inter-cabinet control cable connectors at 1C-N15 and 2C-N15, the No. 1 line circuit panel LP connector at LP1-J, the normally closed contacts (9) (L25) of the BR1 relay or the normally open contacts (8), now closed, of the BR3 relay, the normally open contacts (6), now closed, of the SC relay to the upper terminal U of the SC relay.
- (g) The operation of the SC relay removes an electrical shunt by its normally closed contacts (7) (L26) now open, across the S select relay. The operating circuit of the S relay may then be traced from the common battery return in the No. 1 line circuit panel LP to the upper terminal U of the S relay, and from the lower terminal L of the relay to the S resistor (K26) to +120 volt battery of the power distribution circuit.
- (h) The operation of the S relay (K26) completes the operating circuit of the SM cross-bar selecting magnets (K15) associated with the No. 1 signal line circuit and thereby connects the selector unit (LS) (D6) to the No. 1 line. The operation of the S relay also lights the associated SELECT lamps in the manual switch panel CCMSP (B30) and open line disable panel CCOLP (C30) and starts the timing circuit which limits the

length of time the SC relay is held operated.

- (i) The operating circuit of the SM cross-bar selecting magnets associated with the No. 1 signal line circuit may be traced from the common battery return in the No. 1 line circuit panel LP, the normally open contacts (4) (K25), of the S relay, the No. 1 connector at LP1-E, the inter-cabinet control cable connectors at 2C-A3 and 1C-A3, the No. 1A cross-bar connector at 1AXB-A5, to one side of its SM-0 selecting magnet (K19), and from the other side of the magnet to the No. 1A cross-bar connector at 1AXB-A3, the No. 1 cross-bar connector at 1XB-A5, to one side of its SM-0 selecting magnet (K15), and from the other side of the magnet to the No. 1 cross-bar connector at 1XB-A3, the answer back control panel ABCP connector at AB-S, the closed contacts of the SM toggle switch (20 CKT position), the SM-1 and SM-2 diodes, the SM-2 resistor, the ABCP connector at AB-V to +48 volt battery of the power distribution circuit at connector PL-J.
- (j) The operation of the S relay (K26) lights the SELECT lamps previously mentioned, by means of the common battery return in the No. 1 line circuit panel LP through the normally open contacts (10) (C27), now closed, of the S relay, the No. 1 LP connector at LP1-f, to the open line disable panel CCOLP connector at LCL-S7, its No. 1 line circuit SELECT-1 lamp to +48 volt battery in the CCOLP panel from its connector at LCL-U9 (F14), the inter-cabinet power cable connectors at 2P-012 and 1P-012 to the power distribution circuit, and also from LP1-f to the manual switch panel CCMSP connector at AP-P1, its No. 1 line circuit SELECT -1 lamp to +48 volt battery in the CCMSP panel from its connector at AP-U9 (G14), the inter-cabinet power cable connector at 2P-012 and 1P-012 to the power distribution circuit.
- (k) The operation of the SM cross-bar selecting magnets associated with the No. 1 signal line circuit completes the connection of the selector portion of the switching package to the No. 1 line. This connection can be traced from the common battery return in the No. 1 line circuit panel LP through the spacing contacts (1,5) (Q26), of the 1A incoming line relay, the No. 1 LP connector at LP1-C, the inter-cabinet control cable connectors at 2C-S1 and 1C-S1 (P14), the No. 1 cross bar connector at 1XB-N1 (D10), the normally open contacts (1,2), now closed, of the SM-0 magnet, the No. 1 cross bar connector at 1XB-U1, the answer-back control panel ABCP connector at AB-A to the driver (D7) of the 28 type selector unit line relay (LS) terminal R, and to the No. 1 (GA) answer-back signal generator via its connector LD-1, and to the No. 2 (LTRS B Z) answer-back signal generator via its connector F-0.

- (1) With the No. 1 signal line circuit restored to its original idle (marking) condition, the BR1 relay (N27) will again operate and in approximately 1/2 second the slow-release BR2 relay will restore to its un-operated position. The operating circuit of the HM cross-bar holding magnets associated with the No. 1 signal line circuit is now completed and may be traced from common battery in the No. 1 line circuit panel LP (G26), the normally open contacts (2), now closed, of the S relay, the normally open contacts (8), now closed, of the BR1 relay, the normally open contacts (10), now closed, of the BR3 relay, the normally closed contacts (9) of the BR2 relay, the AB diode, the No. 1 LP connector at terminal LP1-F, the open line disable panel CCOLP connector at LC1-F8, the normally closed contacts (14,13) of the locking No. 1 NORMAL-DISABLE key ND-1, the CCOLP connector at LC1-E3, the inter-cabinet control cable assembly connectors at 2C-C13 and 1C-C13, the No. 2 cross-bar switch connector at 2XB-C15 to one side of the HM-0 holding magnet (F19), and from the other side of the magnet to the No. 2 cross bar connector at 2XB-C13, the No. 1 cross-bar connector at 1XB-C15 to one side of the HM-0 holding magnet (F15), and from the other side of the magnet to the No. 1 cross-bar connector at 1XB-C13 to +48 volt battery of the power distribution circuit at connector PL-J.

- (m) The holding circuit of the HM-0 cross-bar holding magnets (F19) associated with the No. 1 signal line may then be traced from one side of the HM-0 holding magnet in the No. 2 cross bar switch to its connector at 2XB-C15, the No. 1 cross-bar switch connector at 1XB-F8 (N14), the normally open contacts (1,2), now closed, of the HM-0 (1XB) holding magnet, the No. 1 cross-bar switch connector at 1XB-F10, the inter-cabinet control cable assembly connectors at 1C-F8 and 2C-F8, the open line disable panel CCOLP connector at LC1-G13, the normally closed contacts (16,17) of the locking No. 1 NORMAL-DISABLE key ND-1, the CCOLP connector at LC1-J3, to the No. 1 line circuit panel LP connector at LP1-H (M25). The holding circuit now follows a parallel path through the normally open contacts (2), now closed, of the BR3 relay, and also through the HM diode, and the spacing contacts (C,A) of the BRC relay to the No. 1 LP connector at LP1-u. The holding circuit continues to the monitor printer disconnect terminal strip at terminal MPD-1 (M41), to the applique disconnect terminal strip at terminal AFD-1. The holding circuit now follows another parallel path through the manual switch panel CCMSP connector at AP-K2, the normally closed contacts (3,2) of the non-locking headquarter's busy release key HQBR to the common battery return of the CCMSP panel and also through the inter-cabinet control cable assembly connectors at 2C-U11 and 1C-U11, the No. 1 cross-bar switch connector at 1XB-M2, the normally open contact (2nd position), now closed, made by the operation of the SM-0

selecting magnet and the HM-0 holding magnet, the No. 1 cross-bar switch connector at LXB-U13, the local power connector at PL-H & K of the power distribution circuit to common battery return (B43).

The holding circuits of the cross-bar holding magnets associated with signal lines numbered 2 through 20 may be observed to follow similar paths until they reach the APD terminal strip. These circuits then follow a parallel path through the CCMSP connector at AP-D2 through F8, the normally closed contacts (4,5) of the locking NORMAL-CALL keys NC-2 to 20 to the common battery return of the CCMSP panel and also through the common control relay panel CCRP connector at CP1-A5 through B6 and CP2-A3 through B6, the normally closed contacts (as indicated) of the EC1 or EC2 emergency call relays to the common battery return (B38) of the CCRP panel.

- (n) In addition to the operation of the cross-bar switch holding magnets (HM-0's) associated with the No. 1 signal line circuit, the No. 1 (GA) answer-back trip magnet ABTM is operated. The No. 1 ABTM operating circuit may be traced from common battery in the No. 1 line circuit panel LP, the normally open contacts (2) (G26), now closed, of the S relay, the normally open contacts (8), now closed, of the BR1 relay, the normally open contacts (10), now closed, of the BR3 relay, the normally closed contacts (9) of the BR2 relay, the normally open contacts (6), now closed, of the BR1 relay, the normally closed contacts (7) of the BR2 relay, the normally open contacts (1), now closed, of the S relay, the No. 1 LP connector at LP1-L, the inter-cabinet control cable assembly connectors at 2C-N9 and 1C-N9, the answer-back control panel ABCP connector at AB-L, the No. 1 (GA) answer-back connector at LD-17 to the trip magnets (H30), and from the magnets to the No. 1 answer-back connector at LD-19, the parallel circuit consisting of the RAB1 resistor, the CAB1 capacitor (F34) and the CAB2 capacitor to +120 volt battery in the ABCP panel from its connector at AB-T and the power distribution circuit (R5) at connector PL-M.
- (o) The operation of the cross-bar holding magnets (HM-0'S) associated with the No. 1 signal line circuit, completes the operating circuit of its associated X line connecting relay. The operating circuit of the X relay may be traced from the common battery return of the power distribution circuit at the connector PL-H & K (H18), the No. 1 cross-bar switch connector at LXB-U13, the normally open contacts (3,4), now closed, of the HM-0 holding magnet associated with the No. 1 signal line, the No. 1 cross-bar switch connector at LXB-J3, the inter-cabinet control cable assembly connectors at 1C-J3 and 2C-J3, the common control relay panel CCRP connector at CP1-G1, the normally open contacts (1), now closed, of the

ABC answer-back control relay, the CCRP connector at CP1-G3, the No. 1 line circuit panel LP connector at LP1-R, the normally closed contacts (8), of the SR line selecting relay, the normally open contacts (6), now closed, of the BG break generating relay to the upper terminal U of the X relay, and from the lower terminal L of the relay to +48 volt battery (H26). The holding circuit of the X relay may then be observed to be the same as its operating circuit through the inter-cabinet control cable assembly connectors at 1C-J3 and 2C-J3. The holding circuit then follows the path through the No. 1 LP connector at LP1-D, the normally open contacts (2), now closed, of the X relay to the upper terminal U of the X relay.

- (p) The operation of the X relay completes the operating circuit of BUSY lamps in the open line disable panel CCOLP and the manual switch panel CCMSP. This circuit may be traced from the common battery return in the No. 1 line circuit panel LP to the normally open contacts (4) (C27), now closed, of the X relay, the No. 1 LP connector at LP1-C, the open line disable panel CCOLP connector at LC1-M2 to terminal 1 of its BUSY-1 lamp and from terminal 2 of the lamp to the CCOLP connector at LC1-N7, the manual switch panel CCMSP connector at AP-M2 to terminal 1 of its BUSY-1 lamp (C34) and from terminal 2 of the lamp to +48 volt battery in the CCMSP panel which enters at AP-U9 via the inter-cabinet power cable assembly connectors at 2P-O12 and 1P-O12 (F13), of the power distribution circuit.
- (q) The operation of the X relay, by virtue of its normally closed contacts (3) (N27), now open, breaks the operating circuit of the slow release BR1 relay which restores to its unoperated position after approximately 1/2 second. The operation of the X relay, by opening its normally closed contacts (5) (M26), also opens the operating and holding circuits of the BR2 relay. The operating circuit of the SC relay is broken by both the opening of the normally closed contacts (7) (L26), of the X relay and also by the opening of the normally open contacts (6) of the BR2 relay.
- (6) Outlying Station Request for Own Circuit (Refer to Sequence Chart No. 2)
- (a) With the selector portion of the switching package connected to the signal line circuit of the calling station, its operator may keyboard the call directing code (CDC) of the line circuit desired. In this case, the operator (assumed to be on the No. 1 signal line) merely types his own circuit CDC (XA) and awaits a confirmation from the switching package. The CDC is received by the 28 type selector unit which responds by closing a pair of normally open contacts corresponding to the CDC. These contacts operate in conjunction with protective universal contacts within the selector unit. This action completes the operating circuit of the associated SR (K27) line selecting relay which may be traced from common battery return of the power distribution circuit at the local

power connector PL-H & K (P6) to the answer-back control panel ABCP connector at AB-X, the 28 type selector unit LS connector at S-35 (M28), the normally closed LS universal contacts, the normally open XA contacts, now closed, the LS connector at S-1, the inter-cabinet selector unit cable assembly connectors at 1S-A and 2S-A, the LS terminal strip at terminal LS-1, the SR terminal strip at SR-1, the No. 1 line circuit panel LP connector at LP1-h, the SR diode, to the upper terminal U of the SR relay, and from the lower terminal L of the relay to +48 volt battery of the No. 1 LP panel. The holding circuit of the SR relay may then be traced from the upper terminal U of the relay to the normally open (1) contacts, now closed, of the SR relay, the normally open (4) contacts, now closed, of the BG relay to the common battery return in the No. 1 LP panel.

- (b) The operation of the SR relay opens the operating circuit of the BG (K26) break generating relay which may be traced from the common battery return in the No. 1 line circuit panel LP to the normally closed contacts (6), now open of the SR relay, to the upper terminal U of the relay, and from the lower terminal L of the relay to +48 volt battery of the No. 1 LP panel. The BG relay is a slow release type which restores to its un-operated position in approximately 1/2 second.
- (c) The release of the BG relay, completes the operating circuit of the No. 1 (GA) answer-back trip magnet ABTM (H30). This circuit may be traced from the common battery return in the No. 1 line circuit panel LP (F28) to the normally open contacts (5), now closed, of the SR relay, the normally closed contacts (5) of the BG relay, the No. 5RT terminal on the No. 1 LP panel, the No. 1 LP panel connector at LP1-b, the open line disable panel CCOLP connector at LC1-C13, the normally closed contacts (8,7) of the NORMAL-DISABLE switch N D-1, the CCOLP connector at LC1-B8, the No. 1 LP panel connector at LP1-a, the normally open contacts (6), now closed, of the X relay, the normally open contacts (8), now closed, of the S relay, the No. 1 LP panel connector at LP1-L, the inter-cabinet control cable assembly connectors at 2C-N9 and 1C-N9, the answer-back control panel ABCP connector at AB-L, the No. 1 (GA) answer-back connector at LD-17 to the trip magnets, and from the magnets to the No. 1 answer-back connector at LD-19, the parallel circuit consisting of the RAB1 resistor, the CAB1 capacitor and the CAB2 capacitor to +120 volt battery in the answer-back control panel ABCP from its connector at AB-T (R7) and the power distribution circuit at connector PL-M.

- (d) The "GA" answer-back is thereby transmitted to both the No. 1 signal line circuit via the associated electronic driver D (P27) of its outgoing line relay LB and also to the 28 type selector unit via the associated driver D (E7) of its line relay LS. The reception of the character "G" by the 28 type selector unit opens the contacts (M31) which were formerly closed in response to circuit CDC (XA). This action opens the operating circuit of the SR relay which restores to its unoperated position and again completes the operating circuit of the BG relay.
- (e) The reception of the "GA" answer-back by the calling station signals the operator that his line circuit will be declared "busy" to the rest of the network. The operator may then transmit to other stations on his circuit and place those desired in a printing condition. As little time as possible should elapse before the operator releases the selector portion of the switching package. This is accomplished by transmitting the "end of address" code (CARRIAGE RETURN LINE FEED) which is received by the 28 type selector unit. The selector unit responds by momentarily opening the normally closed "CR LF" contacts (L22) in its stunt box which are located in the holding circuit of the SC (L26) relay. The SC relay restores to its unoperated position and thereby shunts the S relay by means of its normally closed contacts (7). The S relay also restores to its unoperated position and opens the operating circuit of the SM (K15 & K19) cross-bar selecting magnets associated with the No. 1 signal line circuit by means of its normally open contacts (4) (K25). The release of these SM cross-bar magnets disconnects the selector portion of the switching package from the No. 1 signal line.
- (f) The calling station operator may now identify himself or transmit the text of the message to the stations desired on his own circuit.

- (7) Second "line break" signal recognition for "end of message" release of line circuit connection. (Refer to Sequence Chart No. 3).
- (a) The "end of message" code following the message text is a second "line break" signal identical in nature to the first "line break" signal described in Section II, 2.a.(5). The "line break" signal recognition is controlled by the BRC relay which has its winding located in the signal line circuit. A "line break" signal will remove the battery from the BRC relay and cause its marking contacts (A, D) to open and its spacing contacts (A, C) to close. By so doing, the ground connection for the BR3 relay is broken and the BR3 relay is thereby de-energized, its other holding circuit having been removed from the common battery return at the normally open contacts (4), now open, of the BR2 relay.
- (b) After the "line break" signal is removed, battery is again applied to the BRC relay causing its spacing contacts (A,C) to open and its marking contacts (A, D) to close. This will now cause the HM-O holding magnet to de-energize because its last holding circuit is broken by the operation of the BRC relay. The holding circuit follows a parallel path through the normally open contacts (2) (M25) now open, of the BR3 relay, and also through the HM diode (M26), and the spacing contacts (C, A), now open, of the BRC relay to the No. 1 line circuit panel LP connector at LP1-u. (For the rest of the description of the holding circuit refer to Section II, 2.a.(5)(m).)
- (c) When the HM-O holding magnet de-energizes this removes the holding circuit from the X relay causing it to de-energize. This holding circuit is traced from the common battery (H17) return of the power distribution circuit at the connector PL-H & K, the No. 1 cross-bar switch connector at LXB-U13, the normally open contacts (3,4), now open, of the HM-O holding magnet associated with the No. 1 signal line, the No. 1 cross-bar switch connector at LXB-J3, the inter-cabinet control cable assembly connectors at 1C-J3 and 2C-J3, the No. 1 line circuit panel LP connector at LP1-D, the normally open contacts (2), now closed, of the X relay to the upper terminal U of the X relay. When the X relay de-energizes the BUSY lamps are turned off. (For the operating circuit of the BUSY lamps refer to Section II, 2.a.(5)(p).) At this point the circuit will now appear idle to the rest of the network.

- (d) The releasing of the X relay, by virtue of its normally closed contacts (3), now closed, completes the operating circuit of the BRL relay, causing the BRL relay to operate. The BRL relay then remains operated until the next "line break" signal is received.
- (8) Station call from one circuit to another. (Refer to Sequence Chart No. 4).
- (a) With the selector portion of the switching package connected to the signal line circuit of the calling station, its operator may keyboard the call directing code (CDC) of the line circuit desired. Let us assume, for example, that the operator (in this case on the No. 1 line circuit) types the CDC of the No. 3 line circuit, XC, and awaits a confirmation from the switching package. The CDC is received by the 28 type selector unit which responds by closing a pair of normally open contacts corresponding to the CDC. These contacts operate in conjunction with protective universal contacts within the selector unit. This action completes the operating circuit of the associated SR (K27) line selecting relay which may be traced from common battery return of the power distributing circuit at the local power connector PL-H & K (P6) to the answer-back control panel ABCP connector at AB-X, the 28 type selector unit LS connector at S-35 (M28), the normally closed LS universal contacts, the normally open XC contacts, now closed, the LS connector at S-3, the inter-cabinet selector unit cable assembly connectors at 1S-C and 2S-C, the LS terminal strip at terminal LS-3, the SR terminal strip at SR-3, the No. 3 line circuit panel LP connector at LP3-h, the SR diode, to the upper terminal U of the SR relay, and from the lower terminal L of the relay to +48 volt battery of the LP panel. The holding circuit of the SR relay may then be traced from the upper terminal U of the relay to the normally open (1) contacts, now closed, of the SR relay, the normally open (4) contacts, now closed, of the BG relay to the common battery return in the LP panel.
- (b) The operation of the SR relay now completes a ground path to the D driver (P27) which can be traced from the common battery return (N25) in the No. 3 line circuit panel LP to the normally open contacts (4), now closed, of the SR relay, the normally open contacts (2), now closed, of the BG relay, the normally closed contacts (1), now closed, of the X relay, the No. 1RT terminal on the line panel, the No. 3 LP connector at LP3-Y, the open line disable panel CCOLP connector at LC2-D6, the normally closed contacts (2,1) of the ND-3 normal-disable control switch (Q31), the CCOLP panel connector at LC2-A7, the No. 3 LP connector at LP3-X, to terminal R of the

electronic driver D which operates the LB line relay. With common battery return potential applied to terminal R of the driver, the driver output is cut off the LB relay is de-energized. (For a complete description of this action refer to Section II, 2.a.(3)(b).)

- (c) When the LB relay de-energizes its marking contacts (4, 1) open and its spacing contacts (1, 5) close. This will appear as a "line break" signal and the BRC relay recognizes it as such and is thereby de-energized. At this point the BR2 and BR3 relays in the No. 3 LP panel (XC circuit) are energized. (For complete description of this action refer to Section II, 2.a.(5)(b) & (c).)
- (d) The operation of the SR relay completes the operating circuit of the HM holding magnets. This circuit may be traced from the common battery return in the No. 3 line circuit panel LP (G26) to the normally open contacts (10), now closed, of the SR relay, the normally closed contacts (11) of the X relay, the No. 3 LP connector at LP3-F, the open line disable panel CCOLP connector at LC1-F12, the normally closed contacts (13, 14) of the NORMAL-DISABLE switch ND-3, the CCOLP panel connector at LC1-E7, to the inter-cabinet control cable connectors at 2C-D6 and 1C-D2, the No. 2 cross-bar switch connector at 2XB-D8, to the No. 2 cross-bar switch holding magnet at HM-2, to the No. 2 cross-bar switch connector at 2XB-D6, to the No. 1 cross-bar switch connector at 1XB-D8, to the No. 1 cross-bar switch holding magnet at HM-2, to the No. 1 cross-bar switch connector at 1XB-D6 and then to +48 volt battery from the power distribution circuit connector at PL-J.
- (e) The operation of the SR relay also opens the operating circuit of the slow release relay BG by means of the normally closed contacts (6), now open. When the BG relay finally releases it opens the ground path to the driver D (P27). This circuit can be traced from the common battery return (N25) in the No. 3 line circuit panel LP to the normally open contacts (4), now closed, of the SR relay, the normally open contacts (2), now open, of the BG relay, and so on, as previously described in this section, paragraph (b). With the common battery return removed from the driver D, terminal R, the output again energizes the LB relay causing its marking contacts (4, 1) to close and its spacing contacts (1, 5) to open.
- (f) When the LB relay operates, it again causes the BRC relay to operate. This appears as the end of the "line break" signal to the No. 3 (XC) circuit. When the XC circuit is idle and is reached by another circuit an answer-back signal "GA" is transmitted to the originating circuit. The "GA" is sent by means of the No. 1 answer-back trip magnet ABTM. The operating circuit of this trip magnet may be traced from +120 volt battery in the answer-back control panel ABCP (F35), through

the parallel circuit consisting of the RAB1 resistor, the CAB1 capacitor and the CAB2 capacitor, to the No. 1 answer-back connector at LD-19, to the trip magnets, and from the magnets to the No. 1 answer-back connector at LD-17, the answer-back control panel ABCF connector at AB-L, the inter-cabinet control cable assembly connectors at 1C-N9 and 2C-N9 (H28), the No. 3 line circuit panel LP connector at LP3-L, the normally closed contacts (6), now closed, of the X relay, the No. 3 LP connector at LP3-a, the open line disable panel CCOLP connector at LC1-B12, the normally closed contacts (7,8) of the NORMAL-DISABLE key ND-3, the CCOLP panel connector at LC1-D2, the No. 3 LP connector at LP3-b, the No. 5RT terminal on the LP panel, the normally closed contacts (5), now closed, of the BG relay, the normally open contacts (5), now closed, of the SR relay, to the common battery return in the LP panel (F28).

- (g) When the No. 1 answer-back trip magnet operates it opens the operating circuit of the ABC relay (H22) through its normally closed auxiliary contacts. The operating path of the ABC relay can be traced from the common battery return in the answer-back control panel ABCP, through the No. 1 answer-back connector at LD-7 (H19), the normally closed auxiliary contacts, now open, of the No. 1 answer-back, the No. 1 answer-back connector at LD-8, the ABCF panel connector at AB-C, the inter-cabinet control cable connectors at 1C-N7 and 2C-N7, the common control relay panel CCRP connector at CP1-T4, the normally open contacts (11) now closed, of the BG3 relay, to the U terminal of the ABC relay, from the L terminal of the ABC relay to the +48 volt battery in the CCRP panel.
- (h) When the No. 1 answer-back trip magnet is energized the transmission of "GA" starts. As soon as the first character "G" is received in the 28 type selector the normally open contacts XC, now closed, in the stunt box are tripped and this in conjunction with the universal contacts opens the operating circuit of the SR relay. This operating circuit can be traced from the common battery return in the answer-back control panel ABCP, to the 28 type selector unit connector at S-35, through the normally closed contact of the 28 type selector's universal contacts, previously opened, to the normally open contacts XC, now open, in the 28 type selector's stunt box, the 28 type selector unit's connector at S-3, the inter-cabinet control cable connectors at 1S-C and 2S-C, the XC terminal on the 1S terminal strip, the No. 3 terminal on the SR terminal strip, the No. 3 line circuit panel LP connector at LP3-h, to the SR diode, the U terminal of the SR relay, and from the L terminal to +48 volt battery in the LP panel. The holding circuit for the SR relay had been previously broken by means of the normally open contacts (4), now open, of the BG relay.

- (i) The releasing of the SR relay causes the BG relay to operate by completing its operating path. The operating path may be traced from the +48 volt battery (K27) in the LP panel, to the L terminal of the BG relay, from the U terminal of the BG relay to the normally closed contacts (6), now closed, of the SR relay and then to the common battery return in the LP panel.
- (j) At this time the end of the "GA" transmission occurs and the auxiliary contact on the No. 1 answer-back closes, thus operating the ABC relay by completing its operating path. This operating path was just described in this section, paragraph g.
- (k) The operation of the ABC relay causes the X relay to operate by completing its operating circuit. The operating path of the X relay may be traced from the common battery return of the power distribution circuit at the connector PL-H & K (H18), the No. 1 cross-bar switch connector at LXB-U13, the normally open contacts (3, 4), now closed, of the HM-2 holding magnet associated with the No. 3 signal line circuit, the No. 1 cross-bar switch connector at LXB-J3, the inter-cabinet control cable assembly connectors at 1C-J15 and 2C-J15, the common control relay panel CCRP connector at CP1-G13, the normally open contacts (3), now closed, of the ABC answer-back control relay, the CCRP connector at CP1-G15, the No. 3 line circuit panel LP connector at LP3-R, the normally closed contacts (8) of the SR line selecting relay, the normally open contacts (6), now closed, of the BG relay to the upper terminal U of the X relay, and from the lower terminal L of the relay to +48 volt battery (H26). The holding circuit of the X relay may then be observed to be the same as its operating circuit through the control cable assembly connectors at 1C-J15 and 2C-J15. The holding circuit then follows the path through the No. 3 LP panel connector at LP3-D, the normally open contacts (2), now closed, of the X relay to the upper terminal U of the X relay.

With the operation of the X relay the internal line of the No. 3 line circuit XC is now connected to the internal line of the No. 1 line circuit XA.

- (l) When the X relay operates it breaks the operating circuit of the BR1 slow release relay by means of its normally closed contacts (3) (N27).
- (m) Now that the XC internal line is connected to the XA internal line, the calling circuit (XA) should be disconnected from the selector portion of the switching package. This is accomplished by means of the "end of address" code (CR LF)

The switching package will now be available for processing the next circuit request. The transmission of the "end of address" code opens the normally closed momentary "CARRIAGE RETURN - LINE FEED" sequence contacts in the 28 type selector unit. This momentary opening of the "CR LF" contacts causes the SC relay associated with the XA circuit to de-energize by breaking its holding circuit. (For a description of this holding circuit refer to Section II, 2.a.(5)(f).)

- (n) The de-energizing of the SC relay places an electrical shunt, by means of its normally closed contacts (7), across the S select relay. The operating circuit of the S relay is traced from the common battery return in the No. 1 line circuit panel LP to the upper terminal U of the S relay, and from the lower terminal L of the relay to the S resistor (K26) to the +120 volt battery in the LP panel. This electrical shunt causes the S relay to release.
- (o) The release of the S relay opens the operating circuit of the SM cross-bar selecting magnets (K15) associated with the No. 1 signal line circuit and thereby the selector unit (LS) is disconnected from the No. 1 line circuit. The selector portion of the switching package is now available to process further circuit requests.

The release of the S relay also turns off the associated SELECT lamps in the manual switch panel CCMSP, and the open line disable panel CCOLP.

- (9) Second "line break" signal recognition for "end of message" release of two circuits connected together. (Refer to Sequence Chart No. 5).

With the calling circuit (XA) connected to the called circuit (XC) and both disconnected from the selecting portion of TASP, the calling station now sends its identification and message. (For a description of how a message is transmitted from one circuit to another refer to Section II, 2.a.(3) and (4).) When the station (AC) operator is through sending his message he indicates he is through by sending an "end of message" line break signal. (Refer to Section II, 1.k.(1)(c).)

- (a) The "end of message" signal is immediately recognized on his own (XA) circuit by the BRC relay as a line break. The BRC relay de-energizes. The LA relay will de-energize as its operating path is also broken when a line break is sent. This operating path can be traced from the signal lines through the LA relay to the +120 volt battery. (For detailed description refer to Section II, 2.a.(2), "Signal Line Circuit".)

- (b) When the LA relay de-energizes its normally open marking contacts (1,4) open, and its normally closed spacing contacts (1,5) close. This breaks the operating circuit of the LBC relay which de-energizes, causing its normally open contacts (12,13) to open. So far all of the action has occurred only on the XA circuit.
- (c) At this point, however, the action is transferred to the other circuit (XC). When the spacing contacts (1,5) of the LA relay close, common battery is applied at that point. This common battery is tied to the second circuit (XC) through the No. 1 cross bar switch. This circuit may be traced from the common battery (P26), through the normally closed spacing contacts (1,5) of the LA relay, to the No. 1 line circuit panel LP connector at LP1-C, the inter-cabinet control cable connectors at 2C-S1 and 1C-S1, and the No. 1 and No. 1A cross bar switch connectors at 1XB-S1 and 1AXB-S1, respectively. By virtue of the fact that the HM-0 and HM-2 holding magnets are both operated, the circuit is further traced through the No. 1 cross bar switch connector at 1XB-P1 (XA circuit) and 1XB-P3 (XC circuit) to the inter-cabinet control cable connectors at 1C-P1 and 1C-P3, and again at 2C-P1, 2C-P3, the No. 1 and 3 LP panel connectors at LP3-B, the normally open contacts (12), now closed, of the X relay in both the XA and XC circuits.
- (d) At this point the common battery is applied at the normally open contacts (12,13) of the LBC relay in both circuits. However, these contacts are open in the sending circuit (XA) and closed in the receiving circuit (XC). From this point on we will trace only the operating circuit in the receiving circuit (XC).
- (e) The common battery path is further traced through the normally open contacts (12,13), now closed, of the LBC relay, the No. 3 LP panel connector at LP3-Y, the open line disable panel CCOLP connector at LC2-D6, the normally closed contacts (2,1) of the NORMAL-DISABLE key ND-3, the CCOLP panel connector at LC2-A7, the No. 3 LP panel connector at LP3-X, to terminal R of the driver D. With common battery applied to terminal R, the driver is cut off and the LB relay is therefore de-energized. When the LB relay de-energizes this causes its normally open marking contacts (1,4) to open and its normally closed spacing contacts (1,5) to close. When the marking contacts are opened a line break is created and therefore the BRC relay is de-energized.

- (f) When the BRC relay de-energizes it causes the BR3 relay to de-energize by interrupting its holding circuit. This circuit may be traced from the +48 volt battery in the No. 3 line circuit panel (M27) to the lower terminal L of the BR3 relay, from the upper terminal U of the relay, to the normally open contacts (4), now closed, of the BR3 relay, the normally closed contacts (5), now closed, of the BR2 relay, the normally open marking contacts (D, A), now open, of the BRC relay, the No. 3 LP panel connector at LP3-u, and from that point on the rest of the operating path is as described in Section II, 2.a.(5)(m).
- (g) When the line break key is released by station AC on circuit XA, this closes the signal line and battery is again applied to the BRC relay causing it to operate. Closing the signal line also causes the LA relay to operate. When the LA relay operates it causes its normally closed spacing contacts (1,5) to open and its normally open marking contacts (1,4) to close. This again applies common battery to the LBC relay, thus operating it (Q26).
- (h) As mentioned in the previous paragraph, the normally closed spacing contacts (1,5) of the LA relay are opened. This now removes the common battery from the cross-bar switch and thus from the receiving circuit. This then removes the common battery from the terminal R of the driver D (P27) and allows it to conduct once more. (This operating circuit was described in the preceding paragraph (e).) When it conducts, it causes the LB relay to operate. When the LB relay operates, its normally open marking contacts (1,4) close thus closing the receiving line once more.
- (i) At this point with both line circuits again closed, and therefore, both BRC relays operated, the holding magnets (HM) for both circuits are de-energized. This is caused by the opening of the normally closed spacing contacts (A, C) of the BRC relay in the holding circuit of the HM holding magnets. (For a detailed description of this holding circuit refer to Section II, 2.a.(5)(m).) It should be pointed out here that the parallel holding circuit for the HM holding magnets at the normally open contacts (2) of the BR3 relay is open because of the de-energizing of the BR3 relay as described in the preceding paragraph (f). With the dropping of the HM holding magnets the internal lines of the two circuits are disconnected from one another.
- (j) When the HM holding magnets are de-energized, their normally open contacts (3, 4) (H19) break the operating circuit of the X relay, thus causing the X relay to de-energize. (A detailed description of this operating circuit may be found

in Section II, 2.a.(5)(o).) It will be noted that the holding circuit for the X relay through the normally open contacts (12) of the SR relay (G25) was previously broken by the de-energizing of the SR relay. When the X relays are de-energized the two circuits (XA and XC) are now idle to the rest of the network.

- (k) The BR1 relay is now operated because of the normally closed contacts (3) of the X relay (N27) in its operating circuit. (For a description of this circuit refer to Section II, 2.a.(5)(a).)

With the operation of the BR1 relay the line circuit is now in the "idle" condition and ready for more business with the rest of the network.

- (10) One Station calls another which is busy. (Refer to Sequence Chart No. 6)

This section will deal with one line circuit (XA) calling another line circuit (XB), with XB being busy to the rest of the network. As described in Section II, 2.a.(5), line circuit XA first is connected to TASP. Since circuit (XB) is busy to the rest of the network, the X relay in the No. 2 line circuit panel is operated.

Line circuit XA now sends the call directing code CDC to the circuit it wants to connect to, in this case XB. The following sequence of action occurs.

- (a) The sending station AC on circuit XA transmits the appropriate CDC for the circuit he wishes to contact, in this case XB. The transmission of XB closes the corresponding set of normally open contacts (M31) in the 28 type selector unit. This action completes the operating circuit of the associated SR line selecting relay. This operating circuit is described in Section II, 2.a.(6)(a).
- (b) When the SR relay operates, it opens the operating path of the BG relay by means of its normally closed contacts (6), now open, thus causing the BG relay to release.
- (c) With the release of the BG relay, the operating circuit of the No. 2 answer-back trip magnet is completed. This circuit may be traced from the +120 volt battery connection in the answer-back control panel ABCP, to the parallel circuitry including the RAB1 resistor and the CAB1 and CAB2 capacitors, to the sequence selector base connector at F-19 to the No. 2 answer-back trip magnet ABTM and from the trip magnet to the sequence selector base connector at F-17, the ABCP panel connector at AB-M, the inter-cabinet control cable connectors at 1C-N5 and 2C-N5, the No. 2 line circuit panel LP connector at LP2-M, the normally closed contact (8) of the S relay, the normally open contact (6), now closed, of the X relay, the No. 2 LP panel connector at LP2-a, the open line disable panel CCOLP

connector at LC1-B10, the normally closed contacts (7,8) of the NORMAL-DISABLE key ND-2, the CCOLP panel connector at LC1-C15, the No. 2 LP panel connector at LP2-b, the 5RT terminal in the LP panel, the normally closed contact (5) (F27) of the BG relay, the normally open contact (6), now closed, of the SR relay, to the common battery return in the LP panel.

- (d) With the operation of the No. 2 answer-back trip magnet ABTM, the code "LTRS BZ" is transmitted to and typed on the circuit XA typing unit and is received by the selector unit in TASP. The "BZ" received by the selector unit in TASP closes the BZ contacts (K6). The closing of the normally open contacts completes the operating circuit of the BZ relay. This circuit may be traced from the common battery return in the answer-back control panel ABCP, to the selector unit connector at S-35 (L5), through the normally open contact, now closed, of the "BZ" selector unit contact, the selector unit connector at S-32, the normally closed contact (8) of the BZBG2 relay, to the upper terminal U of the BZ relay, and from the lower terminal L of the relay to +48 volt battery connection in the ABCP panel. The BZ relay's holding circuit can be traced from the +48 volt battery connection in the ABCP panel (K27) to the lower terminal L of the BZ relay, and from the upper terminal U of the BZ relay, to the normally open contact (2), now closed, of the BZ relay, the normally open contact (8), now closed, of the BZBG1 relay, to the common battery connection on the answer-back control panel ABCP (J7), through the ABCP panel connector at AB-X to the common battery return of the power distribution circuit at the local power connector PL-H & K (P6).
- (e) The operation of the BZ relay completes a common battery circuit to the R terminal of the driver D in the sending (XA) line circuit and also to the driver associated with the sequence selector LS. This common battery circuit to the driver may be traced from the common battery return connection on the answer-back control panel ABCP (G6), to the normally open contact (4), now closed, of the BZ relay, the normally closed contact (5) of the BZBG2 relay to terminal R of the driver D associated with the LS unit and via the ABCP panel connector at AB-A, the No. 1 cross-bar switch connector at LXB-U1, the normally open contacts (1,2), now closed, of the associated selecting magnet SM-0 (D9), the No. 1 cross-bar switch connector at LXB-N1, the inter-cabinet control cable connectors at 1C-S1 and 2C-S1, the No. 1 line circuit panel LP connector at LP1-C (P25), the normally open contacts (12,13) now closed, of the LBC relay, the No. 1 LP panel connector at LP1-Y, the common control relay panel CCRP connector at CP1-B8, the normally closed contact (2) of the BG1 relay, the CCRP connector at CP1-A3, the open line disable

panel CCOLP connector at LC2-D2, the normally closed contacts (1,2) of the NORMAL-DISABLE key ND-1, the CCOLP panel connector at LC2-A3, the No. 1 line circuit panel LP connector at LP1-X to terminal R of the driver D associated with the sending (XA) line circuit.

- (f) The "line break" removes battery from the BRC relay thus releasing it. When the BRC relay releases, its normally open contacts (A, D), open, thus opening the holding circuit of the BR3 relay (M27).
- (g) The operation of the BZ relay opens the operating circuit of the slow release BZBG1 relay (H6), by means of its normally closed contact (6), now open.
- (h) The BZ contacts in the selector release upon reception of the "line break" signal and thus open the operating circuit of the BZ relay.
- (i) After its time delay the BZBG1 relay releases, opening the operating circuit of the BZ relay by means of its normally open contact (8). When the BZ relay releases it opens the common battery circuit to the drivers D. It opens this circuit by means of its normally open contact (4) (G7). With common battery removed from the R terminal of the drivers they again conduct and operate the LB and LS line relays.
- (j) The release of the BZ relay again completes the operating circuit of the BZBG1 relay by means of its normally closed contact (6).
- (k) The operation of the LB line relay results in the operation of the BRC relay and causes its spacing contacts (A, C) to open and its marking contacts (A, D), to close. This will cause the HM-0 holding magnet to release by removing the last holding circuit. (This circuit is described in Section II, 2.a.(7)(b).)
- (l) When the HM-0 holding magnet releases, it opens the holding circuit of the X relay causing it to release. (This holding circuit is described in Section II, 2.a.(7)(c).)
- (m) The releasing of the X relay completes the operating circuit of the BR1 relay, by means of its normally closed contact (3), thus causing the BR1 relay to operate.
- (n) When the BR1 relay operates it opens the holding circuit of the SC relay by means of its normally closed contact (9), now open, thus releasing the SC relay. (This holding circuit is described in Section II, 2.a.(5),(f).)

- (o) When the SC relay releases it places an electrical shunt by means of its normally closed contact (7), across the S relay causing it to release. (Refer to Section II, 2.a.(8)(n) for this circuit description.)
 - (p) When the S relay releases it opens the operating circuit of the SM cross-bar selecting magnets (K15) associated with the No. 1 signal line circuit (XA). At this point line circuit XA is disconnected from the TASP circuit selector. The selector portion of the switching package is now available to process further circuit requests.
- (11) A group Call by Station AC on Circuit XA (Refer to Sequence Chart No. 7.)

To establish a group call, the operation shall proceed as previously described to the point where the selector portion of the switching package has been connected to the line of the calling station as indicated by the reception of the first "GA" answer-back from the switching package. To prevent the reception of a "line break" disconnecting signal in the event a called circuit is busy, the operator first transmits the code characters "FIGS Z" informing the switching package that a group call is in process. In response, the switching package shall again transmit the two characters "GA" answer-back to the calling station where it is recorded in the upper print case condition (usually &-) on the typing unit. This is accomplished by the closing of a normally open momentary contact (G30) in the 28 type sequence selector in TASP which responds to "FIGS Z".

- (a) This contact is in the operating circuit of the No. 1 answer-back trip magnet ABTM. This operating circuit may be traced from the common battery connection in the answer-back control panel ABCP (G30) to the 28 type selector unit connector at S-35, to the normally open momentary contact (FIGS Z), to the selector unit connector at S-21, the No. 1 (GA) answer-back connector at LD-17, to the trip magnets, and from the trip magnets to the No. 1 answer-back connector at LD-19, the parallel circuit consisting of the RAB1 resistor, the CAB1 and CAB2 capacitors to +120 volt battery in the answer-back control panel ABCP from its connector at AB-T and the power distribution circuit (R5) at connector PL-M.
- (b) The "FIGS Z" received by the selector unit in TASP also closes a second set of normally open contacts which completes the operating circuit of the BZBG2 relay. This operating circuit may be traced from the common battery return in the answer-back control panel ABCP (H17) to the selector unit connector at S-35, through the normally open contact, now closed, of the "FIGS Z" selector unit contact, the selector unit connector at S-26, to the upper terminal U of the BZBG2 relay, and from the lower terminal L of the relay to +48 volt battery in the ABCP panel. The holding circuit of the BZBG2 relay may then be traced from the common battery return in the No. 1 line circuit panel LP (K25) to the normally open contacts (4), now closed, of the S relay, the No. 1 LP panel connector at LP1-E, the inter-cabinet control cable connectors at 2C-A3 and 1C-A3, the No. 1A cross-

bar switch connector at 1AXB-A5, to one side of its SM-0 selecting magnet (K19), and from the other side of the magnet to the No. 1A cross-bar connector at 1AXB-A3, the No. 1 cross-bar connector 1XB-A5, to one side of its SM-0 selecting magnet (K15), and from the other side of the magnet to the No. 1 cross-bar connector at 1XB-A3, the answer-back control panel ABCP connector at AB-S, the normally open contacts (2), now closed, of the BZBG2 relay, the BZBG2 diode to the upper terminal U of the BZBG2 relay. These "FIGS Z" contacts in the selector unit release upon reception of the "GA" answer-back signal and thus open the operating circuit of the BZBG2 relay.

- (c) The calling station will now transmit a LTRS character followed by the call directing codes of all the line circuits desired, waiting for an answer-back after each request. If the desired circuit is idle, the switching package shall momentarily break the line of that circuit, and transmit a "GA" answer-back to the calling circuit. If the called circuit is busy or disabled, the switching package shall transmit a "LTRS BZ" answer-back to the calling station. (This sequence of action is described in Section II, 2.a.(10)(a), (b), (c), and (d).) However, in this case the BZ relay is not operated because its operating circuit, previously described, is open by virtue of the normally closed contacts (8), now open, of the BZBG2 relay.
 - (d) When the BZ relay fails to operate, the line break disconnecting signal is withheld. (This common battery circuit is described in Section II, 2.a.(10)(e).) So the sending station receives a "BZ" on his typing unit but his line to TASP is not broken by a "line break" signal. He may then continue with his circuit calling. Following transmission of the "end of address" code (CR LF) by the calling station, transmission may proceed on a conference basis among the selected groups.
 - (e) As described in Section II, 2.a.(6)(f), the reception of the "end of address" code by the selector unit in TASP results in the release of S relay in the No. 1 line circuit panel LP. The normally open contacts (4) (K25) of the S relay open the operating circuit of the SM cross-bar selecting magnets associated with the No. 1 line circuit and, in this case, also the holding circuit of the BZBG2 relay.
- (12) Emergency Call by the "Headquarters" (SPHQ) Station (Refer to Sequence Chart No. 8)
- (a) An emergency call may be made from only one line circuit which terminates in the immediate area of the switching package. This is the No. 1 line circuit and is designated "Headquarters" (SPHQ). The headquarter's operator is provided with a manual switch panel CCMSP for selecting those line circuits to be included in the emergency call. A line circuit that is connected to the selector portion of the switching package and those that are in a busy condition are indicated by SELECT and BUSY lamps, respectively. This panel is connected to the switching package by a 25-foot cable and should normally be located adjacent to the headquarter's typing unit.

- (b) The operator places the number one circuit NORMAL-HOLD key on the manual switch panel CCMSP in the HOLD position. This prevents any line circuit except No. 1 from seizing the selector portion of the switching package by opening the operating circuit of the SC select control relays associated with line circuits numbered 2 through 20. (Refer to Section II, 2.a.(5)(d).)
- (c) To call the desired circuits the operator, governed by the indicating lamps, presets the NORMAL-CALL locking type switches (F42) on the manual switch panel CCMSP to the CALL position --- one for each circuit to be included in the emergency call. This action partially opens the holding circuits of the cross-bar holding magnets associated with line circuits numbered 2 through 20. (Refer to Section II, 2.a.(5)(m).)
- (d) Since the headquarter's operator must seize the selector portion of the switching package in the same manner as any other out-lying station operator, that is, by a "line break" signal, he normally cannot enter the switching package until the selector and the No. 1 line circuit are in an idle condition. (Refer to Section II, 2.a.(6)(e).)
- (e) If the emergency call is extremely urgent and another circuit is connected to the selector portion of the switching package, the operator may disconnect that circuit from TASP by depressing the SELECT RELEASE (HQSR) non-locking key (L19) on the panel until the associated SELECT lamp has been extinguished. This action momentarily opens the holding circuit of the SC relay, releasing it and, subsequently the S relay, which controls the SM cross-bar selecting magnets and SELECT lamps. (Refer to Section II, 2.a.(5)(f) and (j).)
- (f) Again, if the emergency call is extremely urgent and the No. 1 line circuit is busy receiving a group called message, the operator may disconnect the No. 1 line circuit from the group by depressing the BUSY RELEASE (HQBR) non-locking key (H42) on the panel until the No. 1 circuit BUSY lamp is extinguished. This action momentarily opens the holding circuit of the HM-0 cross-bar holding magnets associated with the No. 1 line circuit, releasing them and, subsequently, the X relay and BUSY lamps. (Refer to Section II, 2.a.(5)(m) & (7)(c).)
- (g) The operator now operates the LINE BREAK key on his keyboard for approximately 3 seconds and thereby connects the selector portion of the switching package to the No. 1 signal line circuit as described in Section II, 2.a.(5). Having received the first "GA" answer-back from the switching package and, if required, placed his own printer in a printing condition (selective calling feature), the operator returns the NORMAL-HOLD key to the NORMAL position and transmits the character sequence FIGS G to the switching package. The following relay operation may then be observed:

1. The "FIGS G" character sequence is received by the 28 type selector unit which responds by closing a pair of normally open contacts. This completes the operating circuit of the BG1 relay (E25) which may be traced from common battery return of the power distribution circuit at the local power connector PL-H & K (P6) to the answer-back control panel ABCP connector at AB-X, the 28 type selector unit connector at S-35 (E22) the normally open FIGS G contact, now closed, in the selector, the selector unit connector at S-23, the ABCP connector at AB-K, the inter-cabinet control cable assembly connectors at 1C-N11 and 2C-N11, the No. 1 line circuit panel LP connector at LP1-K, the normally open contacts (5), now closed, of the S relay, the No. 1 LP panel connector at LP1-S, the common control relay panel CCRP connector CP1-T8 to the upper terminal U of the BG1 relay and from the lower terminal L of the relay to +48 volt battery in the CCRP panel from its connector at CP1-U9 (E14), the power cable assembly connectors at 2P-012 and 1P-012 to +48 volt battery of the power distribution circuit.
2. The holding circuit of the BG1 relay may then be traced from the upper terminal U of the relay to the normally open contacts (12), now closed, of the BG1 relay, the normally open contacts (12), now closed, of the BG4 relay to common battery return in the CCRP panel from its connector at CP1-U13 (E17), the power cable assembly connectors at 2P-C1 to C15 and 1P-C1 to C15 to common battery return of the power distribution circuit.
3. The operation of the BG1 relay completes the circuit whereby common battery return is applied to the electronic drivers D (P27) of all circuits to be included in the emergency call. A "line break" signal is thereby transmitted to all selected circuits. Refer to Section II, 2.a.(3)(b). This circuit may be traced from the common battery return of the power distribution circuit to the power cable assembly connectors at 1P-C1 to C15 (C15) and 2P-C1 to C15, the common control relay panel CCRP connector at CP-U13, the normally open contacts (8) (N19), now closed, of the BG3 relay, the normally open contacts (4), now closed, of the BG1 relay, the CCRP connector at CP1-T10, the manual switch panel CCMSP connector at AP-A3, the selected normally open contacts (1,2), now closed, of the NC-2 to 20 locking type NORMAL-CALL switches, the associated CCMSP panel connector at AP-A5 to C11, the associated line circuit panel LP connectors at LP2 to 20-V, the D diodes, the No. 1 RT terminal, the LP panel connectors at LP2 to 20-Y, the open line panel COLP connector at LC2-D4 to F10, the normally closed contacts (2,1) of the ND-2 to 20 locking type NORMAL-DISABLE switches, the COLP panel connector at LC2-A5 to C11, the LP panel connectors at LP2 to 20-X to terminal R of the electronic driver D.

4. The operation of the BR1, BR2 and BR3 break recognition relays associated with the selected line circuits previously in an idle condition is identical to that described in Section II, 2.a.(5). The operation of break recognition relays associated with the selected line circuits previously in a busy condition is identical to that described in Section II, 2.a.(7)(a).
5. The operation of the BG1 relay opens the operating circuit of the BG2 (E22) relay. This circuit may be traced from the common battery return in the common control relay panel CCRP (E22) to the normally closed contacts (6), now open, of the BG1 relay to the upper terminal U of the BG2 relay and from the lower terminal L of the relay to +48 volt battery in the CCRP panel. The BG2 resistor and BG2 diode serve only to increase the time required for the slow-release BG2 relay to restore to its un-operation position. The release of the BG2 relay completes the operating circuit of the EC1 (D20) relay which operates to open its holding circuit contacts (B38) of the cross-bar HM holding magnets (F15 & F19) associated with the line circuits selected for the emergency call. Refer to Section II, 2.a.(5)(m). This operating circuit may be traced from the common battery return (D19) in the CCRP panel to the normally open contacts (6), now closed, of the BG3 relay, the normally closed contacts (5), of the BG2 relay to the upper terminal U of the EC1 relay and from the lower terminal L of the relay to +48 volt battery in the CCRP panel.
6. The operation of the EC1 relay completes the operating circuit of the EC2 (D19) relay which functions identically as the EC1 relay. This operating circuit may be traced from the common battery return in the CCRP panel to the normally open contacts (1), now closed, of the EC1 relay to the upper terminal U of the EC2 relay and from the lower terminal L of the relay to +48 volt battery in the CCRP panel.
7. The release of the cross-bar HM holding magnets associated with the line circuits selected for the emergency call also opens the holding circuits of the associated X line connecting relays. The release of the X relays extinguish the associated BUSY lamps. Refer to Section II, 2.a.(7)(c).
8. The release of the BG2 relay opens the operating circuit of the BG3 (E21) relay. This circuit may be traced from the common battery return in the CCRP panel to the normally open contacts (2) of the BG2 relay to the upper terminal U of the BG3 relay and from the lower terminal L of the relay to +48 volt battery in the CCRP panel.

9. The return of the slow-release BG3 relay to its un-operated position opens its normally open contacts (8) (N19) which are located in the electronic driver D grounding circuit thereby ending the "line break" signal being transmitted to all selected circuits.
10. It should be noted that the "line break" signal is also transmitted to those line circuits which although not selected have been previously connected to those which are selected. The "line break" signal to these unselected circuits is terminated when the HM holding magnets of the selected line circuits have released to the un-operated position thereby opening the internal line connection between them.
11. The release of the BG3 relay, by virtue of its normally open contact (6), opens the operating circuit of the EC1 relay. The normally open contacts (1) of the EC1 relay opens the operating circuit of the EC2 relay. The return of the EC1 and EC2 relays to their un-operated position again completes the holding circuit of the cross bar HM holding magnets.
12. The release of the BG3 relay completes the operating circuit of the No. 1 (GA) answer-back trip magnet ABTM (H30). This circuit may be traced from the common battery return in the CCRP panel (G29) to the normally closed contacts (2) of the BG3 relay, the normally open contacts (1), now closed, of the BG4 relay, the CCRP panel connector at CP1-T12, the inter-cabinet control cable assembly connectors at 2C-N9 and 1C-N9, the answer-back control panel ABCP connector at AB-L, the No. 1 (GA) answer-back connector at LD17, to the trip magnets, and from the magnets to the No. 1 answer-back connector at LD19, the parallel circuit consisting of the RAB1 resistor, the CAB1 capacitor and the CAB2 capacitor to +120 volt battery in the ABCP panel.
13. The release of the BG3 relay, by virtue of its normally open contacts (11), opens the operating circuit of the answer-back control relay ABC. The BG3 relay, by virtue of its normally open contacts (1), also opens the operating circuit of the BG4 relay.
14. When the BG4 relay releases, it completes the operating circuit of the UCR relay (D18) by virtue of its normally closed contacts (2). This operating circuit may be traced from the +48 volt battery in the CCRP panel, to the lower terminal L of the UCR relay, from the upper terminal U of the UCR relay, to the normally closed contacts (2), of the BG4 relay, the normally open contacts (1), now closed, of the BG1 relay, to the common battery return of the

common control relay panel CCRP through its connector at CP1-U13, the power cable assembly connectors at 2P-C1 to C15 and 1P-C1 to C15, to the common battery return of the power distribution circuit (C14).

15. With the operation of the UCR relay a line break is transmitted to the selected line circuits. This is accomplished by completing the common battery circuit to the terminal R of the driver D. This circuit may be traced from the common battery connection at the common control relay panel CCRP (N19), to the normally open contacts (21), now closed, of the UCR relay, the CCRP panel connector at CP1-T10, and so on, as described in Section II, 2.a.(12)(g) 3. The out-off of the driver D in the selected circuits causes the release of the LB relay which in turn causes the release of the BRC relay. This is to further condition the selected line circuits by bringing about the operation of the BR2 and BR3 relays.
16. In addition, the UCR relay completes the operating circuit of all the selected holding magnets (HM). This circuit can be traced from the +48 volt battery of the power distribution circuit at connector PL-J(F18), the No. 1 cross-bar switch connector at 1XB-C13 to F4 and the No. 1A cross-bar switch connector at 1AXB-C13 to F4, the holding magnets HM-0 to 9 in both the No. 1 and 1A cross-bar switches, the No. 1 and 1A cross-bar switch connectors at 1XB-C15 to F6 and 1AXB-C15 to F6, the No. 2 and 2A cross-bar switch connectors at 2XB-C13 to F4 and 2AXB-C13 to F4, the holding magnets HM-0 to 9 in both the No. 2 and 2A cross-bar switches, the No. 2 and 2A cross-bar switch connectors at 2XB-C15 to F6 and 2AXB-C15 to F6, the inter-cabinet control cable connectors at 1C-C13 to F6 and 2C-C13 to F6, the open line disable panel CCOLP connectors at LC1-E3 to F6 and LC3-E3 to F6, the normally closed contacts (13,14) of the associated NORMAL-DISABLE locking type keys ND-1 to 20 (G22), the CCOLP panel connectors at LC1-F8 to G11 and LC3-F8 to G11, the common control relay panel CCRP connectors at CP1-B14 to E3 and CP2-B10 to E3, the normally open contacts (2 to 20), now closed, of the UCR relay, the CCRP panel connectors at CP1-B12 to E1 and CP2-B8 to E1, the manual switch panel CCMSP connector at AP-G3 to J13 and AP-G1 to J15, the normally open contacts (7, 8), now closed, of the associated NORMAL-CALL keys NC-2 to 20, to the common battery return on the CCMSP panel, through its connector at AP-U13 (C16), and the inter-cabinet power cable connectors at 2P-C1 to C15 and 1P-C1 to C15, to the common battery return of the power distribution circuit.

17. After the No. 1 answer-back trip magnets operate and the "GA" transmission has started, the receipt of the first character "G" trips the latched FIGS G contact, thus releasing it and opening its normally open contacts (E22). This breaks the operating path of the BG1 relay thus releasing it. (For a description of this operating circuit refer to Section II, 2.a.(12)(d) 1.)
18. The release of the BG1 relay opens the operating circuit of the UCR relay by means of its normally open contacts (1). The release of the UCR relay removes the common battery from the drivers D of all the **selected line circuits by means of its normally open contact (21).** The drivers are thus allowed to conduct again, operating their outgoing line relays LB, which close the line circuit by means of their normally open marking contacts (1,4), now closed, thus ending the "line break" signal to all the selected line circuits. With the line break closed, battery is again applied to the BRC relay, thus operating it.
19. When the BG1 relay releases, it also completes the operating circuit of the BG2 relay by means of its normally closed contacts (6), thus operating the BG2 relay (E22).
20. The operation of the BG2 relay completes the operating circuit of the BG3 relay by means of its normally open contact (2), now closed, thus operating the BG3 relay.
21. The operation of the BG3 relay completes the operating circuit of the BG4 relay by means of its normally open contact (1), now closed, thus operating the BG4 relay (E20).
22. The operation of the BG3 relay also completes the operating circuit of the ABC relay by means of its normally open contact (11), now closed, thus causing the ABC relay to operate. (The operating circuit of the ABC relay is described in Section II, 2.a.(8)(g).)
23. The operation of the ABC relay, by virtue of its normally open contacts (1 to 20), now completes the operating circuit of the X relay of all of the selected circuits. When the X relays operate, all of the selected internal lines are connected to the XA (SPHQ) internal line. The operation of the X relay opens the operating circuit of the BR1 relay by means of its normally closed contacts (3), now open, causing the BR1 relay to release.

- (e) With the release of relays BR1 and BR2 (which was released by the operation of the BRC relay, see this section, paragraph 18.) the selected circuits are now fully conditioned for the emergency call from line circuit XA (SPHQ). At this time the headquarter's operator will transmit the "end of address" code (CR LF) which shall disconnect the headquarter's circuit from the selector portion of the switching package. However, before the switching package can recognize another bid for another circuit connection, the select NORMAL-HOLD key (M37) must be returned to the NORMAL position.

The emergency message text may now be transmitted by the headquarter's station. Upon message completion, the end of message code may be transmitted by either the headquarter's operator or by any called circuit operator. As before, this is normally a second "line break" signal which is transmitted by depressing the LINE BREAK key of the page printer for approximately 3 seconds. This signal is recognized by the switching package to disconnect all circuits. (Refer to Section II, 2.a.(7).)

(13) Power Distribution and Fuse Alarm Circuits
(Refer to 4461WD)

(a) General Description

1. Purpose and Functions

The power distribution circuit is for use with the cabinets and associated circuits of the TASP system at a station designated as the control office or headquarters. The 117AC power is distributed to the sequence selector and the rectifier assemblies. The -40, +48 and +120 V.D.C. power is received from the associated rectifiers and distributed to the line circuits, answer-back circuits and all others.

Also provided are audible and visual indications in the event of power failures, fuse alarms and service alarms. An alarm cutoff feature by the operation of a key is provided.

2. Functional Designations

a. Relays

BR - Buzzer Release
FAI - -40V Fuse Alarm
FA2 - +48 and +120 Fuse Alarm
RF1 - -40 Rectifier Failure
RF2 - +48 Rectifier Failure
RF3 - +120 Rectifier Failure

b. Keys

BR - Buzzer Release

c. Lamps

AC - Indicates when power switch is in off position.

CAB ALM - Service Alarm and Cabinet Pilot

FA - Fuse Alarm

40V FAIL - Indicates failure of -40V Rectifier

48V FAIL - Indicates failure of +48V Rectifier

120V FAIL - Indicates failure of +120V Rectifier

AC FAIL - Indicates failure of -40V, +48V and +120V Rectifiers

3. Operational Features

- a. AC power required for the operation of the sequence selector and rectifiers is provided by a power plug-in strip.
- b. DC power required for the operation of the associated circuits is provided by means of multi-contact connectors and associated cords.
- c. Audible and visual indications for service, power failure and fuse alarms are provided.
- d. By the operation of a key, an alarm cutoff feature is provided.

4. Equipment Arrangements

The power distribution equipment panel is provided on a 23" mounting plate for installation along with the associated units in the equipment cabinet 165801 of the TASP system. It uses standard apparatus and existing rectifiers. It connects to the associated units by means of multi-contact connectors and associated cords.

5. General Operation

a. Power Distribution and Fuse Alarm

The -40V and +48V DC power furnished by one rectifier assembly and the +120V DC power furnished by a separate rectifier assembly are both connected to the fuse panel for distribution to the associated circuits. In the

event of the blowing of a -40V, +48V or a +120V fuse, a buzzer alarm is sounded along with the lighting of the FA and CAB ALM lamps. AC power required for the operation of the

- (1) sequence selector and rectifiers is furnished by power cords plugging into a power plug-in strip in the 165801 equipment cabinet, and the
- (2) buzzer and alarm lamp is furnished by a step-down transformer connected across the 117V supply.

b. CAB Alarm

The buzzer alarm is sounded and the CAB ALM lamp lights whenever any of the fuses in the cabinet fail. A key is provided so that the buzzer alarm can be suppressed. After the trouble has been cleared and the failed fuse is replaced the CAB ALM lamp is extinguished.

c. Rectifier Failure Alarm

The failure of both rectifiers is indicated by the lighting of the AC FAIL lamp, the CAB ALM lamp and the sounding of the buzzer. In the event of one rectifier failing, the corresponding power alarm lamp will light along with the CAB ALM lamp and the sounding of the buzzer.

(b) DETAILED DESCRIPTION

1. Application of Main AC Power

The AC power required for the "P" power plug-in strip and the "F" transformer is obtained by means of the 3 conductor K cord plugging into the subscriber's convenience outlet. On the application of the AC, if the PWR switch is in the off position an indication will be given by the lighting of the AC lamp.

2. Normal Condition

The normal condition of the power distribution circuit is defined as the period in which the PWR switch is on and the circuit is supplying power to the associated circuits in the equipment cabinets. During this time all lamps are extinguished and the RF1, RF2 and RF3 relays are held operated by the -40V, +48V and +120V rectifiers respectively. All other relays are nonoperated.

3. Fuse Alarm

If a -40, +48 or +120 volt fuse blows, -40, +48 or +120 volts, supplied by the corresponding rectifier is applied from the fuse alarm bar to operate the corresponding FA1 or FA2 relay and light the FA lamp through its normally open contact (1). When the FA1 or FA2 relay operates, it also sounds the C buzzer and lights the CAB ALM lamp through its normally open contact (11).

4. CAB Alarm

The operation of either of the above alarm relays causes the CAB ALM lamp to light and the C buzzer to operate. The buzzer can be silenced by the operation of the BR key through its normally open contacts (1,2). This operates relay BR via diode BR. When the BR relay operates it locks itself on and opens the operating path of the buzzer by means of its make-break contact (6). After the trouble has been cleared, ground is removed which causes the BR relay to release and extinguishes the CAB ALM lamp.

5. Rectifier Failure Alarm

a. -40 Volt Rectifier Failure

If the -40V rectifier fails, relay RF1 will release. When the RF1 releases, it lights the 40V FAIL lamp through its normally closed contact (8) and sounds the C buzzer and lights the CAB ALM lamp through its normally closed contact (2). The buzzer may be suppressed as described in paragraph b.(4).

b. +48 Volt Rectifier Failure

If the +48V rectifier fails, relay RF2 will release. When RF2 releases, it lights the 48V FAIL lamp through its normally closed contact (8) and sounds the C buzzer and lights the CAB ALM lamp through its normally closed contact (2). The buzzer may be suppressed as described in paragraph b.(4).

c. +120 Volt Rectifier Failure

If the +120V rectifier fails, relay RF3 will release. When RF3 releases, it lights the 120V

FAIL lamp through its normally closed contact (8) and sounds the C buzzer and lights the CAB ALM lamp through its normally closed contact (2). The buzzer may be suppressed as described in paragraph b.(4).

d. -40, +48 and +120 Volt Rectifier Failures

If the -40V, the +48V and the 120V rectifiers all fail relays RF1, RF2 and RF3 will release. When they all release the AC FAIL lamp will light through the normally closed contacts (7) of the three relays. The C buzzer will sound and the CAB ALM lamp will light through the normally closed contacts (2) of the three relays. The buzzer may be suppressed as described in paragraph b.(4).

TASP IS NOT BUSY

TASP CIRCUIT SELECTOR
SEIZED BY CNT. XA

TASP of CIRCUIT
XA 10LE

LINE BREAK KEY.
OPERATED ON CNT.
XA

ALL MOTORS ON CNT. XA
STARTED IMMEDIATELY
UPON LINE BREAK

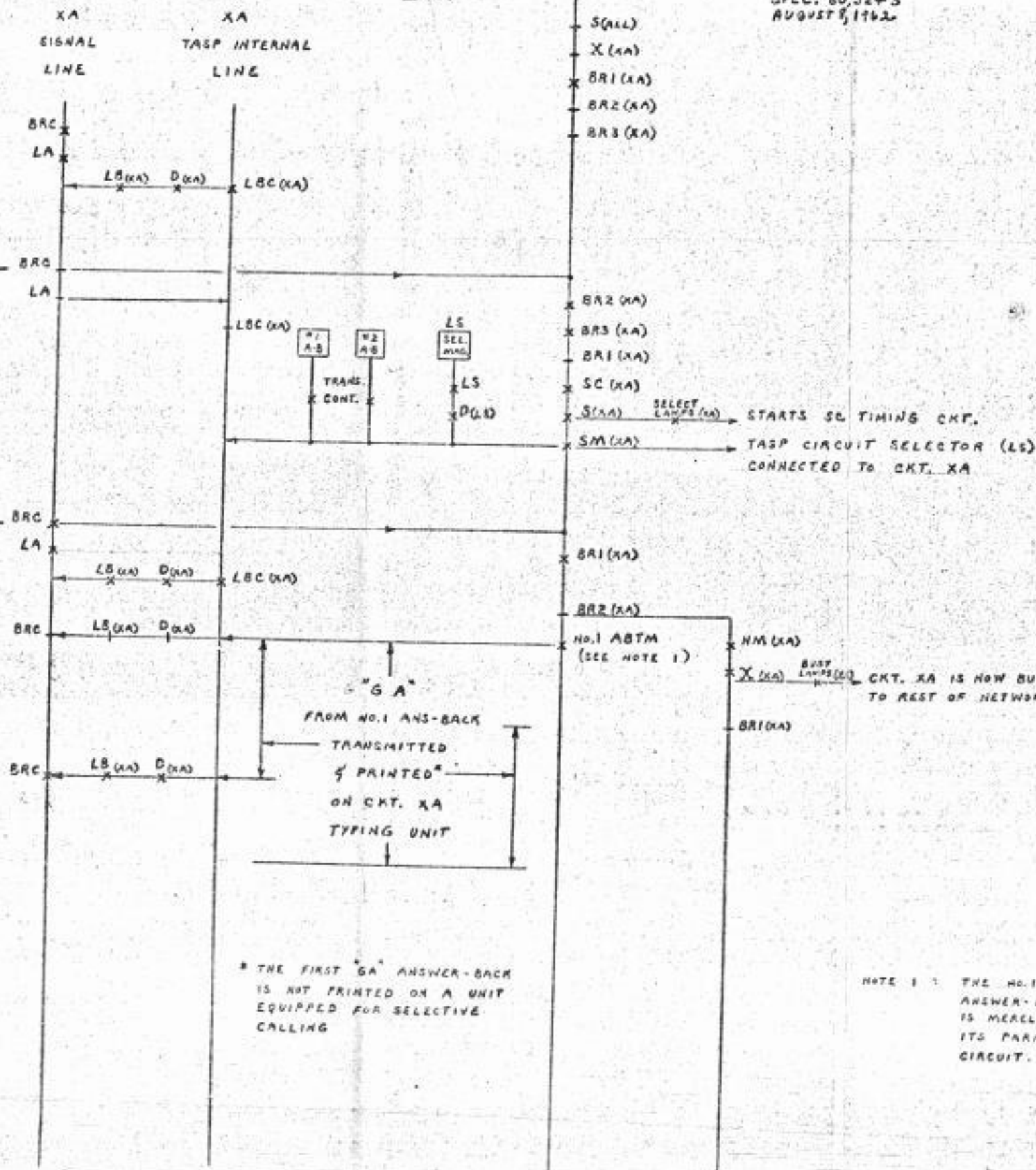

* THE FIRST "GA" ANSWER-BACK IS NOT PRINTED ON A UNIT EQUIPPED FOR SELECTIVE CALLING

NOTE 1: THE NO.1 (GA) OR NO.2 (LTS B2) ANSWER-BACK TRIP MAGNET ABTM IS MERELY PULSED BY VIRTUE OF ITS PARALLEL AC OPERATING CIRCUIT.

STATION ON CIRCUIT XA
CALLS OWN CIRCUIT

STATION AC ON CKT. XA
CALLS CKT. XA

STATION AC ON CKT. XA
SENDS END OF ADDRESS
(CR, LF)

STATION AC SENDS
IDENTIFICATION OF MESSAGE

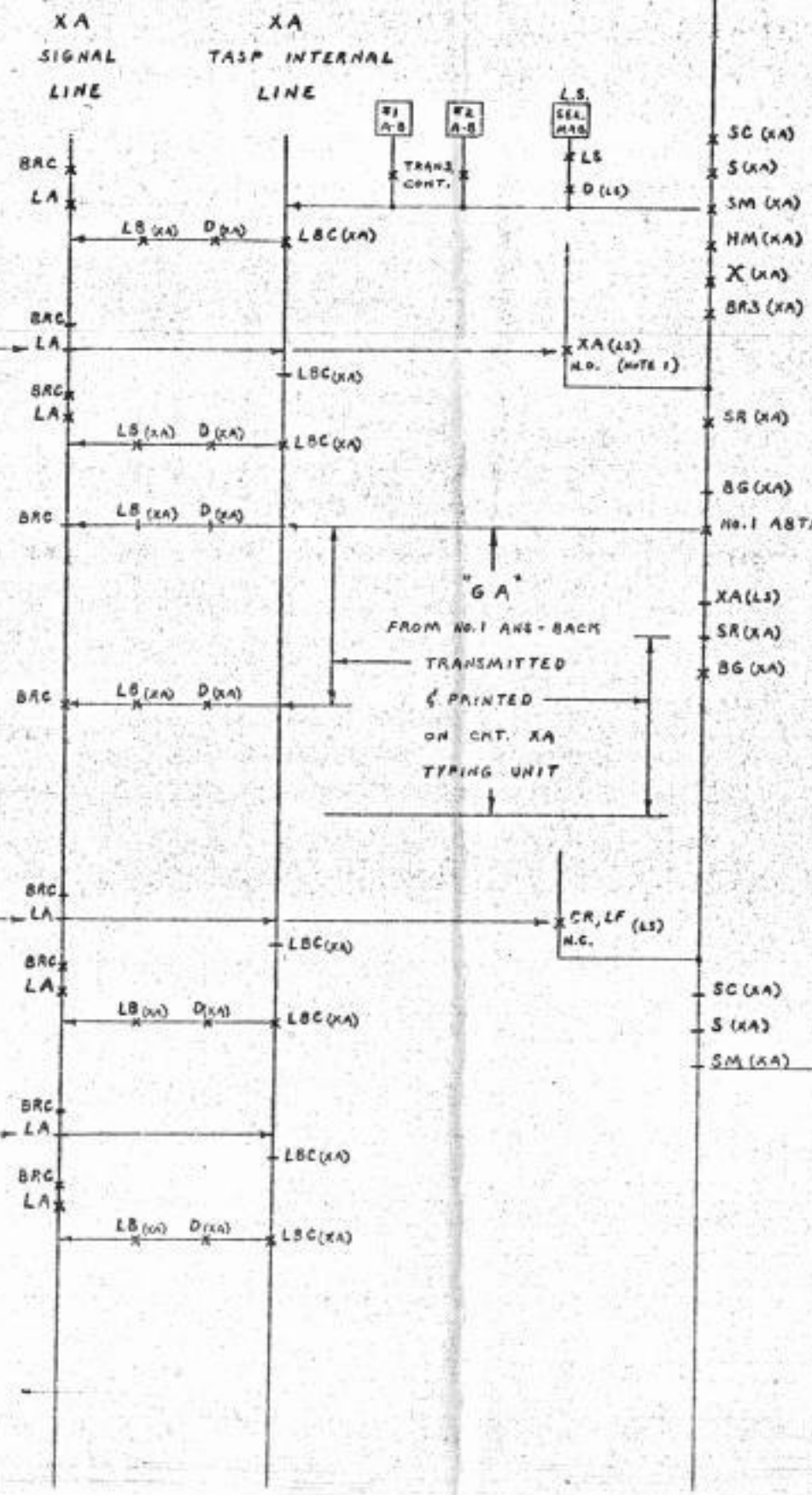

SC (XA)
S (XA)
SM (XA)
HM (XA)
X (XA)
BR3 (XA)
SR (XA)
BG (XA)
No. 1 ABTM
XA (LS)
SR (XA)
BG (XA)
SC (XA)
S (XA)
SM (XA)

TASP CIRCUIT SELECTOR (LS)
DISCONNECTED FROM CKT. XA
INTERNAL LINE

NOTE 1: ALL CDC CONTACTS WITHIN
THE LS UNIT OPERATE IN
CONJUNCTION WITH A PROTECTIVE
UNIVERSAL CONTACT.

STATION ON CIRCUIT XA
CALLS OWN CIRCUIT
(CONTINUED)

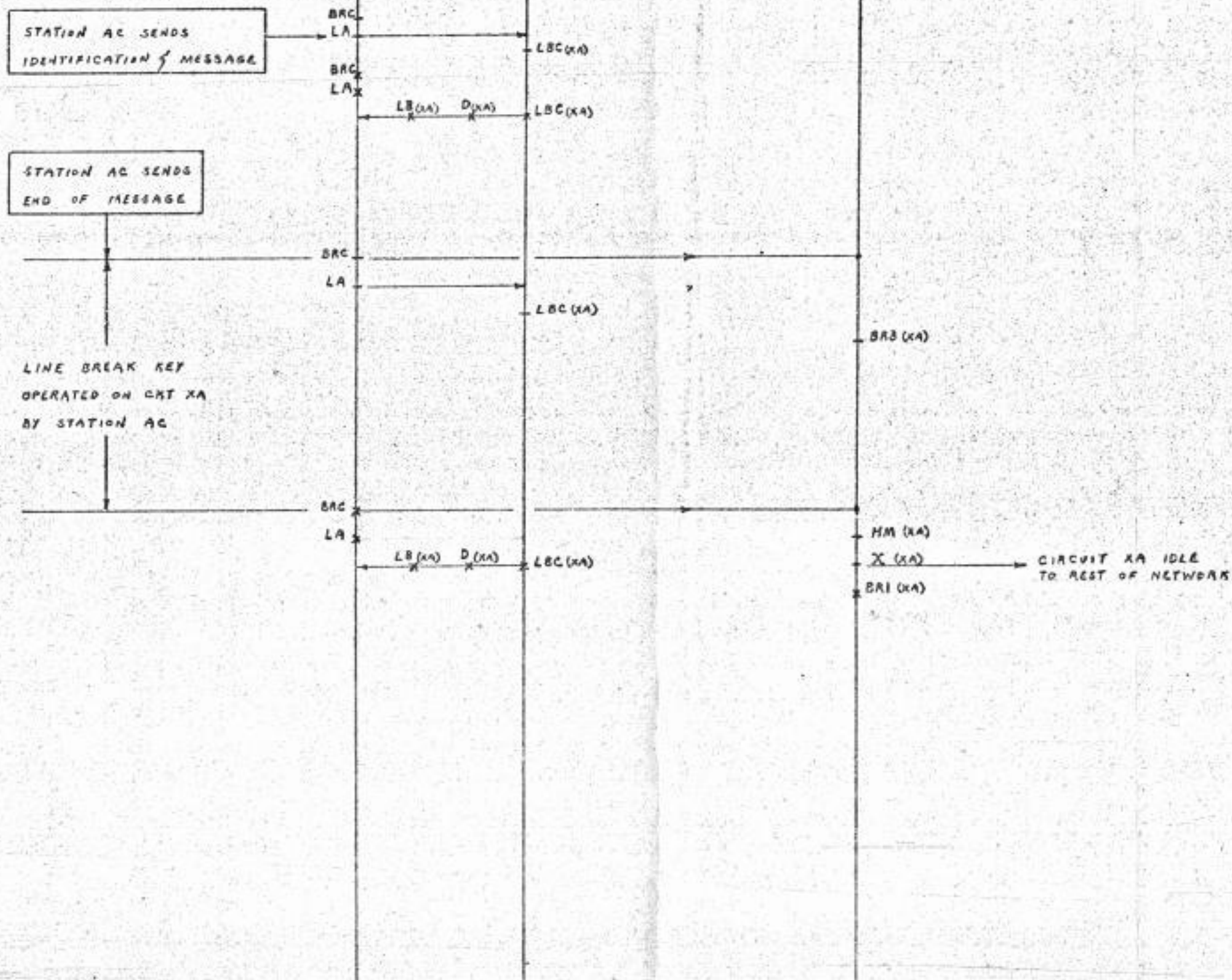

CIRCUIT XC CALLED BY
CIRCUIT XA IS IDLE

STATION AC ON CRT. XA
CALLS CRT. XC (IDLE)

STATION AC ON CRT. XA
SENDS END OF ADDRESS
(CR, LF)

STATION AC SENDS
IDENTIFICATION f MESSAGE

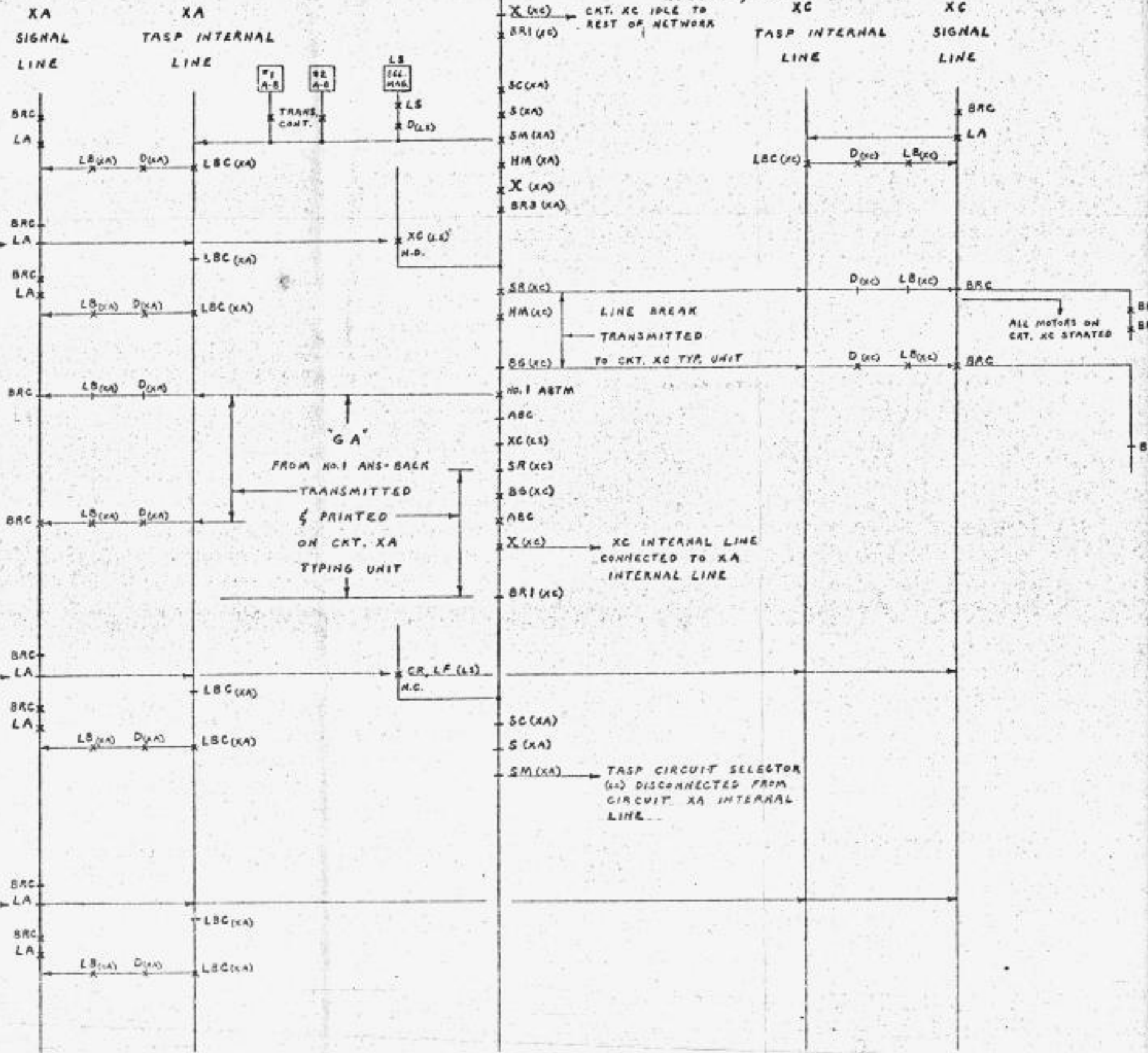

CIRCUIT XC CALLED BY
CIRCUIT XA IS IDLE
(CONTINUED)

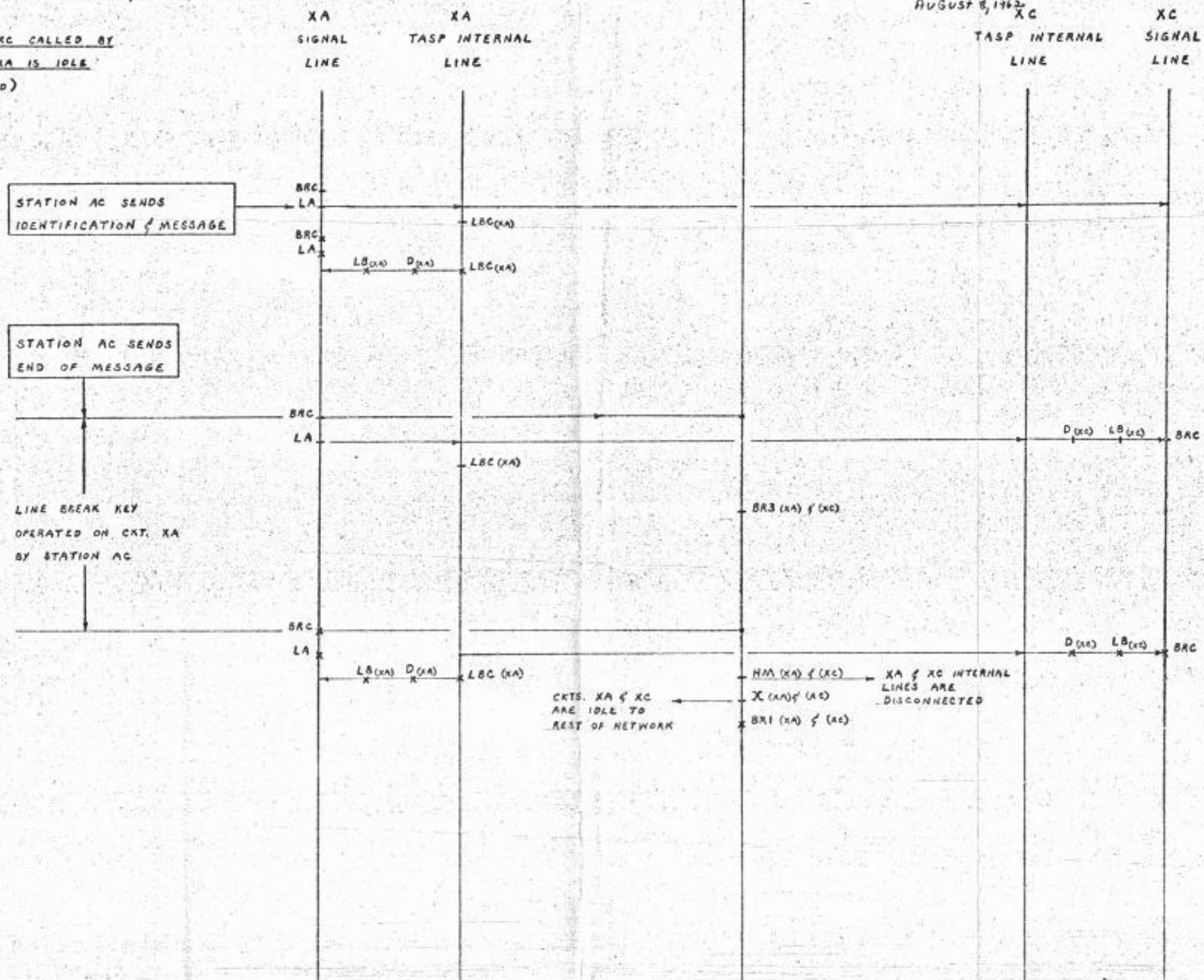

CIRCUIT XB CALLED BY
CIRCUIT XA IS BUSY

STATION AC ON CRT. XA
CALLS CRT. XB (BUSY)

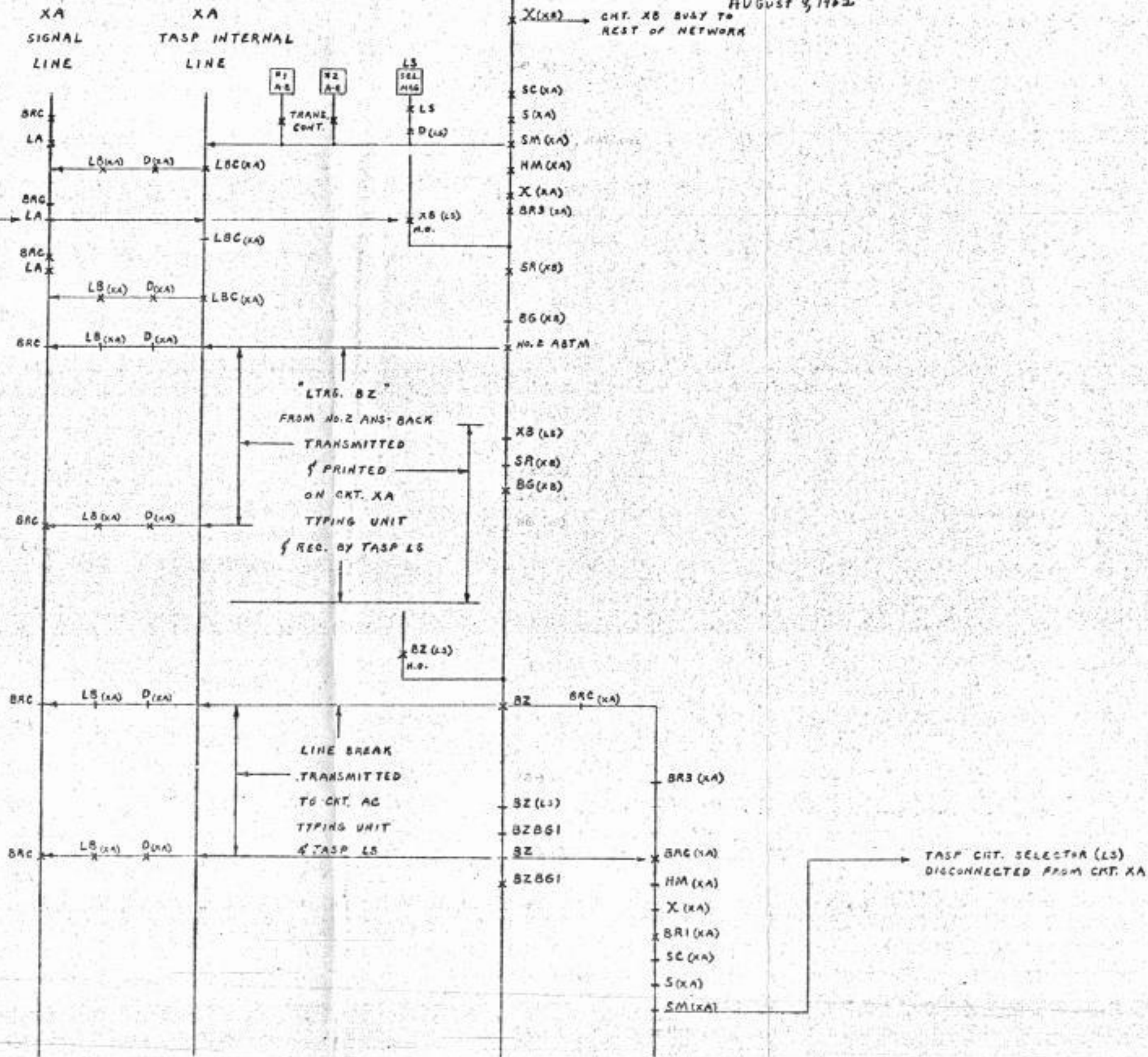

GROUP CALL BY STATION
AC ON CIRCUIT XA

STATION AC ON CKT. XA
HAS RECEIVED 12I "GA"
FROM TASP AND NOW
SENDS "FIG. Z"

STATION AC ON CKT. XA
CALLS CKT. XB (BUSY)

STATION AC ON CKT. XA
SENDS END OF ADDRESS
(CR, LF)

STATION AC SENDS
IDENTIFICATION & MESSAGE

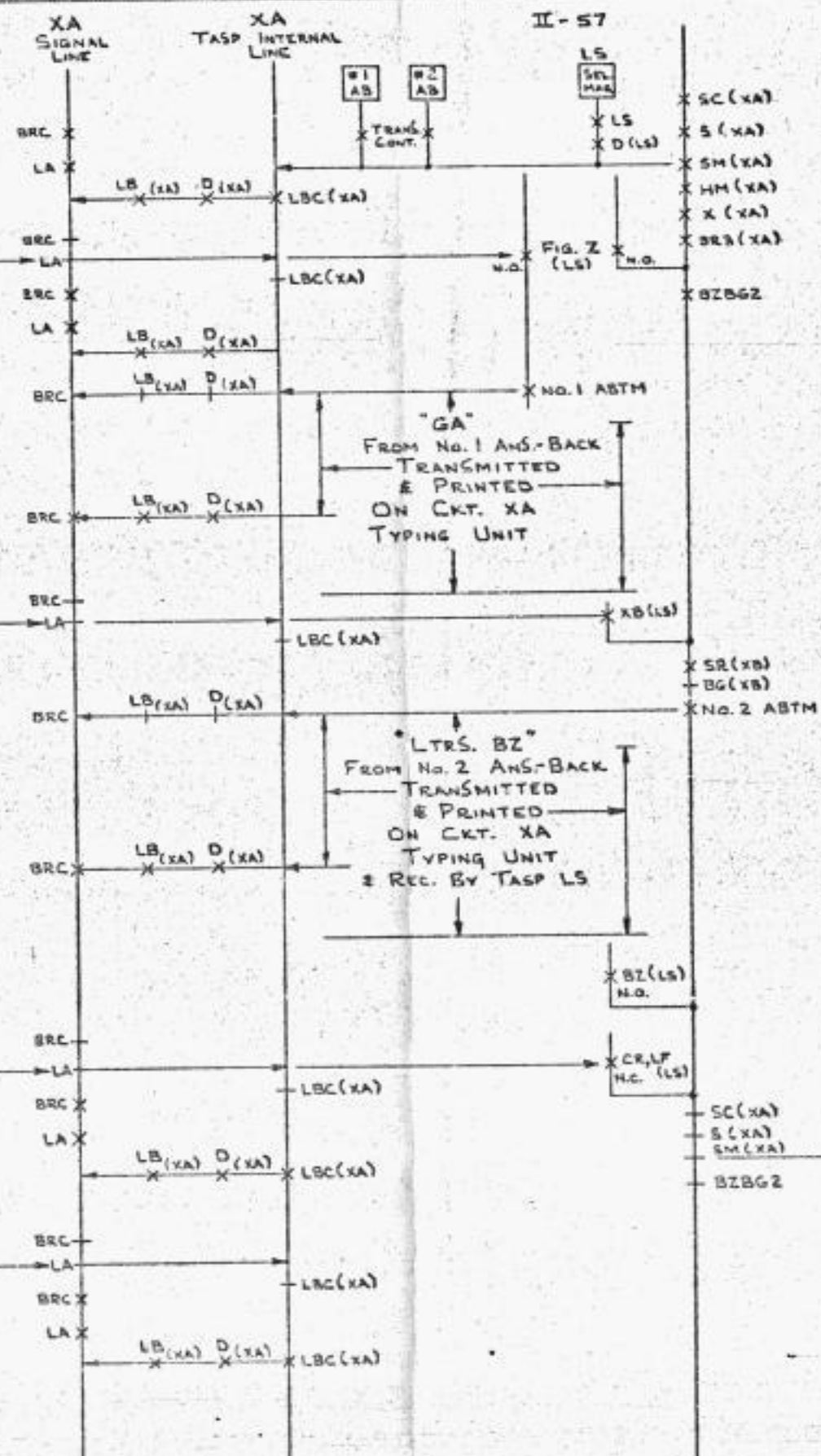

SC(XA)
S(XA)
SM(XA)
HM(XA)
X(XA)
SR(XB)
BG(XB)
BZ(LS)
N.O.
CR, LF
H.C. (LS)
BZBG2 → TASP CIRCUIT SELECTOR (LS)
DISCONNECTED FROM CKT. XA
INTERNAL LINE

EMERGENCY CALL BY SPHQ
STATION AC ON CRT XA

SPHQ STATION AC
SELECTS CIRCUITS
VIA COMSP AND
SENDS FIG. 6

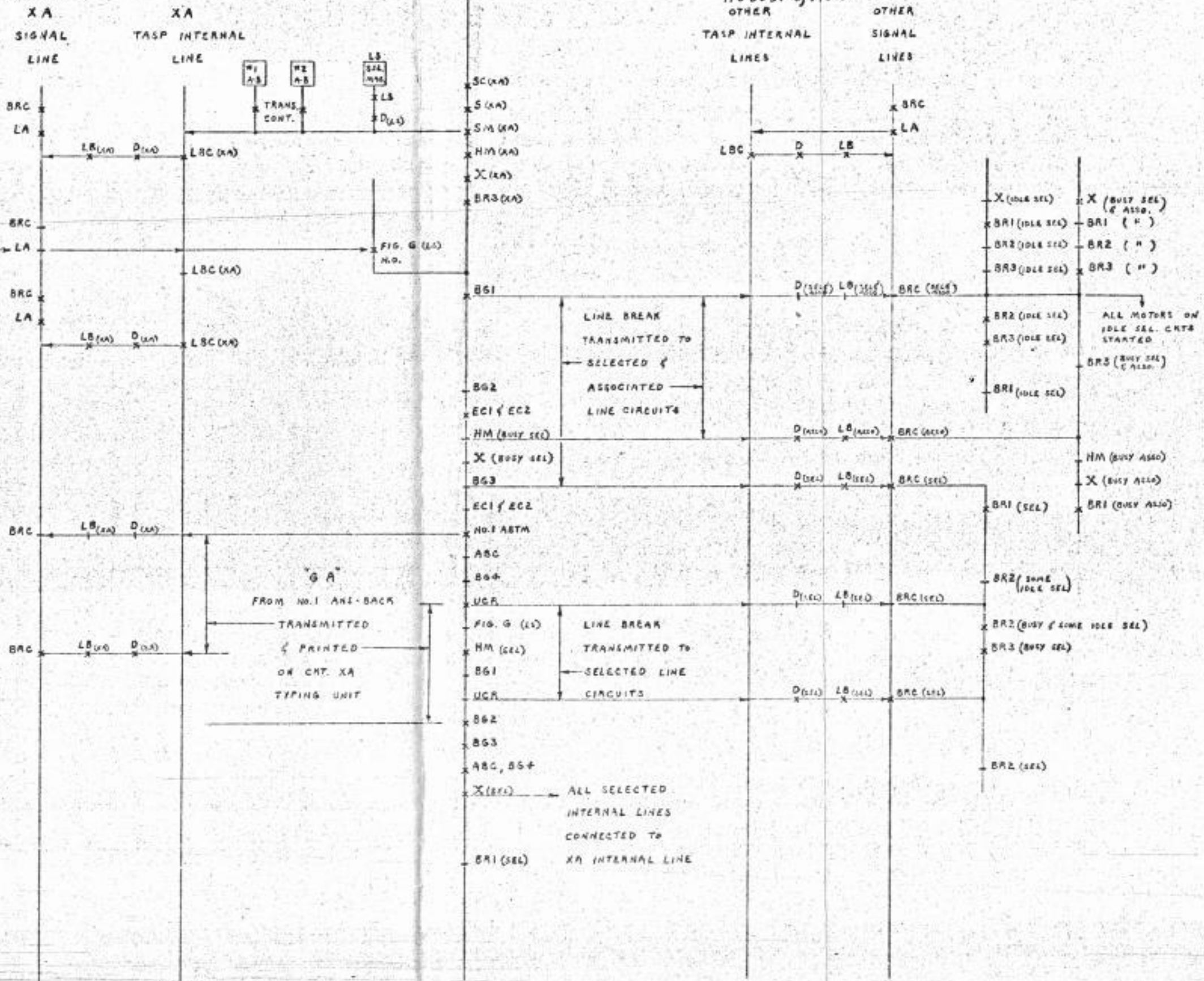

SECTION III

ADJUSTMENTS, SPECIAL REQUIREMENTS AND LUBRICATION

1. ADJUSTMENTS

The adjustments of the particular pieces of equipment making up TASP do not necessarily have to be accomplished in any particular order. Tools and spring scales required to perform the adjustments are listed in Teletype Bulletin 1124B and in the particular specifications, but are not supplied as part of the equipment.

- a. The REC55 and REC56 rectifier assemblies do not have any external adjustments to make. The changes, if any, to be made in these assemblies internally are listed in specifications 9549S and 9550S.
- b. The 165803 (Western Electric 324L) cross-bar switch assembly has its requirements and adjustments described in Bell System Practices, Plant Series, Section 030-720-701.
- c. The 28 Type Sequence Selector base assembly, LSB2 or LSB3, has its description and engineering requirements outlined in Specification 60,179S.
- d. The motor drive assembly for the 28 Type Sequence Selector is the LMU3. The only assembly and adjustment instructions for this motor are located in Bulletin 217B, section one, pages 80 and 81.
- e. The 28 Type Sequence Selector is the LS3. Included with this assembly is the stunt box assembly, arrangement "ADJ" for break disconnect or ADK for the special upper case, blank, H disconnect. All the adjustments for these two assemblies are located in Bulletin 217B or Specification 6442S.
- f. The 164129 set of common answer-back parts is included with the 28 Type Sequence Selector Base, LSB2 or LSB3. Its adjustments are located in Specification 60,179S.
- g. The 165928 Modification Kit to add a universal contact to the stunt box of the 28 Type Sequence Selector, has its adjustments outlined in Specification 60,178S.
- h. The LD14 multiple wire distributor for the 28 Type Sequence Selector LS3, has its adjustments outlined in Specification 60,322S. The LD14 distributor contains the "GA" answer-back mechanism.
- i. The signal current for each line circuit is supplied by TASP and should be adjusted to 0.060 amperes by means of a rheostat and an associated line jack located on the rear of each line circuit panel. The line circuits have a nominal voltage of 120 volts D.C. Excluding the line adjustment rheostat, the total resistance of the equipment connected to a signal line within the switching package is approximately 1200 ohms. Therefore, if the external impedance of a particular line exceeds

800 ohms, it will be necessary to "pad" the line with an additional voltage source to raise the line current back to 0.060 amperes. Suitable line padding resistance must also be added so that irrespective of line conditions, no more than 0.120 amperes shall flow in the signal line.

- j. To prevent any one line circuit from being indefinitely connected to the selector portion of the switching package, a time delay device is used to limit this connection to approximately two minutes. This device is located on the 165959 common control relay panel in the 165802 cabinet. It is supplied with an ON-OFF switch and time delay settings of approximately 100, 80, 60 or 40 seconds are possible by means of a wiring change. Located on the left rear side of the panel are six 22 megohm resistors which are wired into the charging circuit of the CT timing capacitor to provide the full two minute time delay. Strapping any one resistor out of the circuit will reduce the time delay by approximately 20 seconds.

2. SPECIAL REQUIREMENTS

- a. The LA and LB line relays employed in the 165954 line circuit panels and the LS line relay employed in the 165963 answer-back control panel are RY30 (Western Electric 255-A) relays. To operate properly in these circuits, the following adjustments are necessary prior to their installation in the switching package. Refer to Figure 1, Page III-12.
- (1) Efficient operation of this relay depends upon a periodical routine of inspection, cleaning, and adjustment. The adjustments are so interrelated that it is essential for each adjustment to be made in the given sequence. If any adjustment is changed, it will be **necessary to check all subsequent adjustments.**
 - (2) Remove the relay cover and blow out any accumulated dust. Wipe the relay and the cover with a clean soft cloth.
 - (3) Before cleaning or making any adjustments, loosen both pole-piece screw knurled tension knobs and back off both pole-piece screws as far as possible. Back off both contact screws.
 - (4) Pits and build-ups on the contacts should be removed with a contact file. (Back out contact screws to permit entrance of contact file.) When cleaning the armature contacts, the armature should be supported at its mid-position by the opposite contact screw to avoid bending the armature or the contact springs. Care should be taken in filing the armature contacts to use light pressure. After using the file, blow out any loose particles and polish the contacts with a burnisher.
 - (5) Any particles adhering to the armature or pole-piece screws should be removed by pressing a fresh piece of friction tape, wrapped around a piece of thin stiff non-magnetic metal, against the particles. Do not rub the tape against the armature or pole-piece screws as this will leave a residue which will collect further particles.
 - (6) Make sure that pole-piece screws and relay terminals are clean.
 - (7) The armature should not touch the inside of the spool and the contacts should align so that the centers of the contacts will not be out of alignment by more than 25% of the contact diameter.
 - (a) To adjust, loosen the screws holding the spool heads to the relay frame and position the spool to meet the first requirement. Tighten the screws. Loosen the armature clamping screws and position the armature both vertically and horizontally to meet the latter requirement. Tighten the screws.

- (b) If necessary, position the contact screw brackets by means of the enlarged mounting holes in the relay frame to aid in meeting the latter requirement.
- (8) The armature contact springs should be parallel to the armature and the tips of the armature contact springs should rest against each other, approximately flat across their width, with a pressure of 20 to 50 grams measured on one spring at the contact with the other spring held so that it cannot follow its mate. If necessary, back off the contact screws. To adjust the tension of the armature contact spring, bend the spring toward or away from the other contact spring as required, and as close as practicable to the point where it is riveted to the armature. Reset the contact screws.
- (9) The clearance between the armature in its normal unoperated position and either contact screw should be approximately equal and
- (a) when a flat 0.005 inch gauge is placed between the ends of the flexible contact springs, there should be a small contact gap as indicated by placing a continuity tester or an ohmmeter across terminals No. 4 and No. 5 of the relay.
 - (b) when a flat 0.006 inch gauge is placed between the ends of the flexible contact springs, there should be no contact gap on either side and the marking (4) and spacing (5) contacts should be short-circuited as indicated by the continuity tester or ohmmeter.
 - 1. To adjust, back off the pole-piece screws as far as possible and position the contact screws to meet the above requirements.
 - 2. The contact screws should be sufficiently tight in their brackets to hold any adjusted position. If necessary, remove the contact screw from the bracket and force the two portions of the split end of the bracket closer together to meet this requirement.
- (10) The pole-piece screws should be adjusted to meet the following requirements:
- (a) When the armature is held first against one contact screw and then against the other, the armature stop pins should not touch the pole-piece screws.
 - (b) The armature should be centered in the magnetic field between the pole-piece screws, i.e., the armature should either "float" in the gap between the contact screws, or, it should stay against either contact with approximately the same pressure when moved there by hand.

1. To adjust, back off both pole-piece screws and check the contact screw adjustment. Readjust if necessary.
 2. Advance the right pole-piece screw until, with its knurled tension knob tight, the right pole-piece screw pushes the armature far enough to just touch the left-hand contact screw as indicated by a continuity tester or ohmmeter across terminals No. 1 and No. 5 of the relay. Carefully back off the right pole-piece screw $\frac{3}{8}$ turn from this position and tighten the tension knob.
 3. Carefully advance the left pole-piece screw until requirements (a) and (b) are met. Tighten the tension knob. If this disturbs the adjustment, reposition the left pole-piece screw and retighten the tension knob to meet the requirements.
- b. The BRC relays employed in the 165954 line circuit panels are Western Electric 280BA relays. These relays should be adjusted at the factory and do not require frequent re-adjustment. However, heavy use over a long period of time, contact wear, loss of spring tension or other factors may make re-adjustment of these relays necessary to restore them to maximum operating efficiency. Never adjust a relay unless it is certain that the relay does not meet its test requirements. The following adjustments apply to the BRQ relay:

- (1) The armature springs should bear against each other on at least one point and must not have more than a 0.002-inch gap at any point across the front edges. Gauge by eye.

To adjust, back off the contact screws with an adjusting key and adjust tips of the springs, as required, using a spring adjuster. Check that the flexible springs rest against each other in line with the armature with a pressure of 20 to 50 grams measured on one spring at the contact, with the other spring held so that it cannot follow its mate. Use a gram gauge to measure the tension and hold the other spring with the flat end of an orange stick. If necessary, adjust the tension by applying a spring adjuster to the spring as close as practicable to the point where it is jointed to the armature. Reset the contact screws and adjust for contact travel.

- (2) There must be a clearance between the armature and the coil portion of the biasing spring. Gauge by eye.

The straight portion of the biasing spring should rest approximately flat against the armature. This should be considered satisfactory if the top end of the straight portion rests against the armature and the clearance, if any, between the bottom edge of the armature and the straight portion of the biasing spring does not exceed 0.020 inch. Gauge by eye.

If there is no clearance between the armature and the coil portion of the biasing spring, remove the biasing spring screw by pulling it out while turning it slightly back and forth. Exercise care in this operation not to damage the biasing spring. Then reduce the size of the outer coil of the spring by grasping the spring between the thumb and forefinger and turn the biasing screw in a direction which will tighten the spring on the biasing screw. Exercise care not to wind the spring more than necessary to reduce the diameter of the coil the requirement amount. Remount the biasing screw.

If the biasing spring does not rest flat against the armature with the relay in adjustment, remove the biasing screw from the relay and adjust the flat portion of the biasing spring with a pair of smooth jaw pliers.

If the biasing spring is distorted to the extent that it cannot be satisfactorily adjusted, replace it with a new biasing spring assembly.

- (3) The armature shall not touch the inside of the relay coil opening in any position which the armature may assume with the relay either operated or unoperated. Gauge by eye.

If the armature does not clear the inside of the relay coil opening, remove the relay from the base and remove the cover. Slightly loosen the screws holding the armature to its support. Then move the armature up or down as required to bring it into an approximate central position with respect to the coil, noting that the contacts are in alignment.

- (4) Contacts must line up so that the point of contact falls wholly within the boundary of the opposing contact. Gauge by eye.

To align the contacts from front to rear proceed as in (3), shifting the armature in or out as required. If satisfactory alignment cannot be obtained in this manner, loosen the screws holding the contact screw brackets to the base of the relay and then move the brackets until the contacts line up properly. It is desirable to set the contact screw brackets so that the contact screws strike the contacts on the armature as near the center as possible. Tighten the screws securely and remount the relay.

- (5) Contact and biasing screws shall be sufficiently tight in their bracket and biasing spring support respectively, to hold any adjusted position. Gauge by feel.

If the contact screws are not sufficiently tight in the bracket, remove the screw from the bracket and force the two parts of the bracket closer together with long nose pliers. Use an adjusting key to remove and replace the contact screws.

No adjustment is provided for the biasing screw. If the biasing screw is loose, remove and replace with new biasing spring assembly.

- (6) Pole piece screws shall be held sufficiently tight in the pole pieces by the clamping screws to hold them in any adjusted position and still permit the pole piece screws to be turned. Gauge by feel. Use the adjusting key.

Tighten the clamping screws as required.

- (7) The contact travel shall be minimum 0.004 inch, maximum 0.006 inch. The thickness gauge is applied between the armature and either contact.

Remove any build-ups from the contacts before proceeding with this adjustment. If complete readjustment is necessary proceed as follows:

Turn the biasing spring screw so that the spring does not touch the armature. Loosen the pole piece clamping screws and back off the pole piece screws AS FAR AS POSSIBLE. Back off the contact screws sufficiently to permit the armature to assume its free position. The relay armature should be centered in the relay coil opening.

Advance one contact screw until it just touches the armature, and then back it off 1/2 the specified contact travel.

NOTE: The contacts should be in line and meet squarely. Contact screws should be clamped securely.

One twelfth (1/12) of a turn of the contact screw (approximately the distance between the hole centers in the head of the contact screw) corresponds to approximately a 0.002-inch change in contact travel. Repeat this operation with the other contact screw. Check that the armature does not make contact with either contact screw but stands approximately midway between contact points. Check with the proper gauges that the contact travel, measured at the contacts, is within the specified limits.

- (8) With the armature against the right-hand contact screw, turn the right-hand pole piece screw in until there is 0.004-inch space between the pole piece and the armature.

With the armature against the left-hand contact screw, turn the left-hand pole piece screw in until there is 0.004 inch space between the pole piece and the armature.

The armature should now stay against either the right or left contacts when manually positioned. Refine the adjustment of the pole pieces if the above condition does not exist.

NOTE: Clearance between armature and pole piece when armature is against associated contact should not be less than 0.004 inch.

- (9) Before adjusting the bias spring, normal operating current (0.060 amperes) should be passed through the relay in a direction to give the tongue a marking bias (+ polarity on terminal E, - polarity on terminal B). This current should be permitted to pass through the coil of the relay for approximately five seconds and then removed. The tongue of the relay will then rest against the marking contact (contacts A and D closed). Turn the bias spring screw clockwise until the spring has just sufficient tension to move the armature to the spacing contact (contacts A and C closed) plus an additional 1/8 turn.

c. Circuit modifications to permit line circuits to be used in sequentially selected groups with a single call directing code for the group are accomplished by wire strapping changes on the terminal board panel located at the top rear side of the 165802 line circuit panel cabinet. (Refer to wiring diagram 4451WD).

- (1) Line circuits to be included in a group must have the wire straps removed between the associated LS and SR terminal strips and the following wire straps added:

The following schematic wiring diagram combines line circuits 3, 2 and 1 in a sequentially selected groups with a single call directing code (X): (connector designations have been omitted).

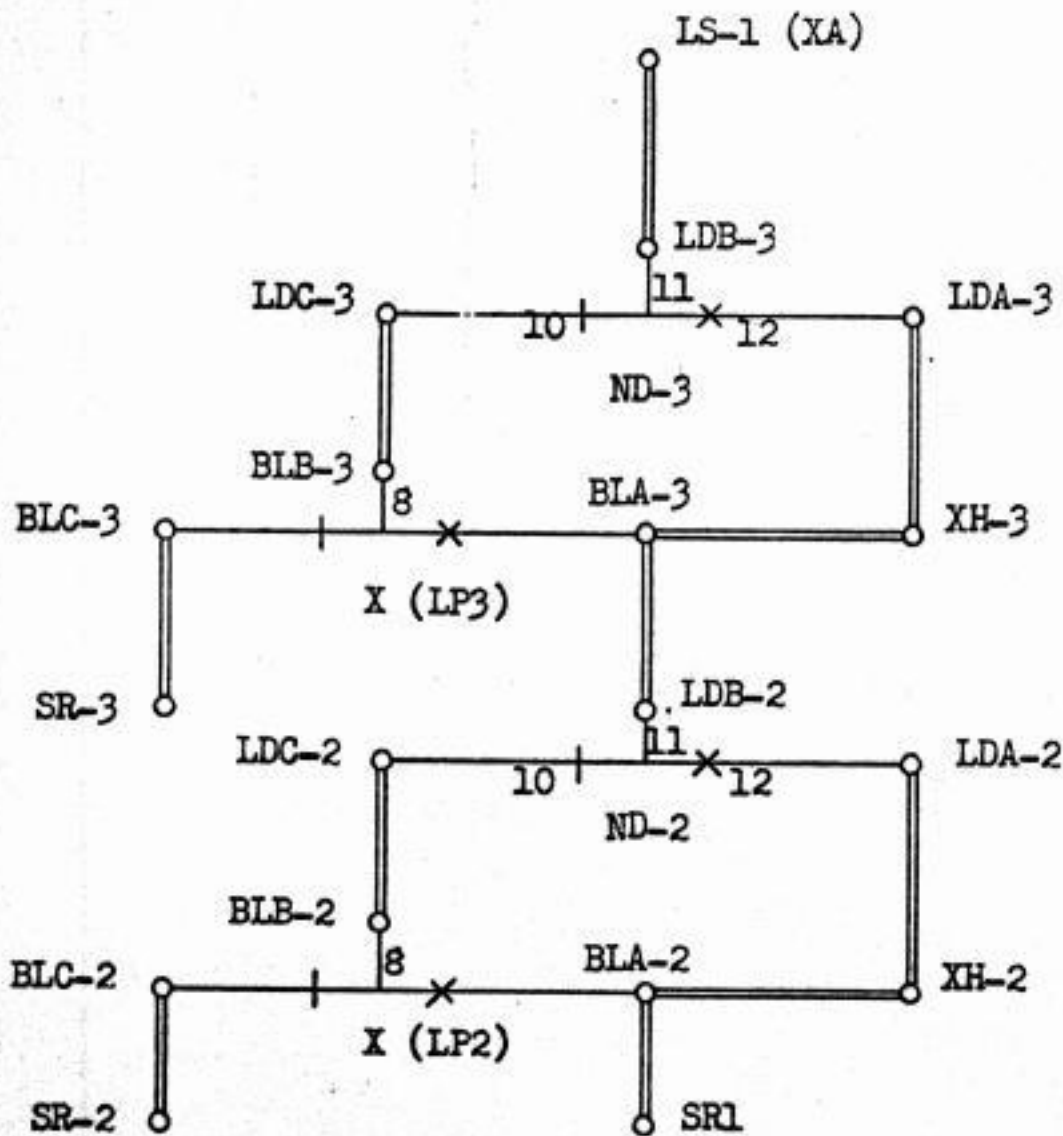

○—○ Indicates wire straps to be added on terminal board panel. Use #24 or larger gauge wire.

- (2) As described in Section II, 2.a.(8), a called line circuit must have its SR relay operated before it can be connected to any other line circuit. With the line circuits 1, 2 and 3 in a normal, idle condition the associated NORMAL-DISABLE (ND) keys and line connecting (X) relays are not operated. The first request for line circuit XA then results in the operation of the SR relay associated with the No. 3 line circuit and its subsequent connection to the calling line circuit. As previously described, the operating circuit of this relay follows a path to the LS terminal strip at terminal LS-1, and now to the LDB terminal strip at terminal LDB-3, the open line disable panel CCOLP connector at LC2-L3, the normally closed contacts (11, 10) of the associated NORMAL-DISABLE (ND-3) key, the CCOLP panel connector at LC2-06, the LDC terminal strip at terminal LDC-3, the BLB terminal strip at terminal BLB-3, the No. 3 line circuit panel LP connector at LP3-n, the normally closed contacts (8) of its X relay, the No. 3 LP panel connector at LP3-p, the BLC terminal strip at terminal BLC-3, the SR terminal strip at terminal SR-3 to the SR relay associated with the No. 3 line circuit.
- (3) With the No. 3 line circuit busy, the next request for line circuit XA results in the operation of the SR relay associated with the No. 2 line circuit and its subsequent connection to the calling line circuit. The operating circuit this relay again follows a path to the LS terminal strip at terminal LS-1, the LDB terminal strip at terminal LDB-3, the CCOLP panel connector at LC2-L3, the normally closed contacts (11, 10) of the associated NORMAL-DISABLE (ND-3) key, the CCOLP panel connector at LC2-06, the LDC terminal strip at LDC-3, the BLB terminal strip at terminal BLB-3, the No. 3 LP panel connector at LP3-n, the normally open contacts (8), now closed, of its X relay, the No. 3 LP panel connector at LP3-m, the BLA terminal strip at BLA-3, the LDB terminal strip at terminal LDB-2, the CCOLP panel connector at LC2-L1, the normally closed contacts (11, 10) of the associated NORMAL-DISABLE (ND-2) key, the CCOLP panel connector at LC2-04, the LDC terminal strip at terminal LDC-2, the BLB terminal strip at terminal BLB-2, the No. 2 LP panel connector at LP2-n, the normally closed contacts (8) of its X relay, the No. 2 LP panel connector at LP2-p, the BLC terminal strip at terminal BLC-2, the SR terminal strip at terminal SR-2 to the SR relay associated with the No. 2 line circuit.
- (4) Similarly, if the No. 3 and No. 2 line circuits are busy, the next request for line circuit XA results in the operation of the SR relay associated with the No. 1 line circuit and its subsequent connection to the calling line circuit. To prevent two "XA" line circuits from being connected to the calling line circuit, the operating circuit of the SR relays is connected to the holding circuit of the associated X relays via the XH terminal strip.
- (5) Calls between stations on the same circuit of this group should not follow the usual procedure as described in Section II.1.k.(1)(b). The transmission of a circuit's own call letters should be omitted following the reception of the first "GA" answer-back from TASP. This omission is necessary to avoid the un-intentional connection of a second circuit in the group to the calling circuit. In this case, the reception of the first "GA" from TASP is sufficient indication that the calling circuit will be reported busy to the rest of the network.

- d. Circuit modifications to permit a change in the circuit disconnect code from the normal second line break signal to an "upper case blank H" code signal are accomplished by wire strapping changes on the terminal board panel located at the top rear side of the 165802 line circuit panel cabinet and also on the DS terminal strips located on the rear side of each line circuit panel. (Refer to wiring diagram 4451WD). These modifications must be accompanied by a change in the "busy" indicating answer-back code from the normal "LTRS B Z" as furnished in the LSB2 Sequence Selector Base to "LTRS B Z LTRS FIGS BL H" as furnished in the LSB3 Base. The associated circuit selector within the switching package must also be changed from LS3/ADJ to LS3/ADK.
- (1) Recognition of the second line break signal by a line circuit is prevented by making the following wire strapping changes on its associated DS terminal strip:
 - (a) Move the white-brown wire lead from terminal No. 1 to terminal No. 2.
 - (b) Move the brown wire lead from terminal No. 3 to terminal No. 4.
 - (c) Move the blue wire lead from terminal No. 5 to terminal No. 6.
 - (2) The recognition of the "upper case blank H" code signal must be done separately for each line circuit in the TASP network. It must be done externally to the switching package by either a Model 28 monitor printer or some other equivalent device located in the immediate area of TASP. In response to the "upper case blank H" code signal the device must open a pair of normally closed contacts for a period of 30 to 250 milliseconds. These contacts must be wired in series with the MPD and APD terminal strip connections associated with the particular line circuit, thereby placing them in the holding circuit of its cross-bar holding magnets. (This circuit is described in Section II, 2.a.(5)(m)). The electrical load of each circuit is approximately 0.075 ampere inductive with spark protection. Naturally, the existing wire straps between the MPD and APD terminals must be removed.
 - (a) Monitor printers may be connected in series with TASP line circuits at any convenient point or by utilizing the terminal strip labeled "MON PTR" located at the top rear side of the 165802 cabinet. An RY30 line relay or a selector magnet driver should be used to couple the printer to the line.
 - (3) The Selective Emergency Call From Headquarters for systems using a second line break signal as an end of message or circuit disconnecting code is described in Section II, 1.k.(4). With an "upper case blank H" disconnecting code, the procedure is similar except that in response to the code sequence "FIGS G", the switching package momentarily breaks the line of all circuits previously selected and also those to which they may be already connected, disconnects only those busy circuit connections which are wholly desired by the headquarters' station, transmits a second "GA" answer-back to headquarters where it is received in the upper print case condition, and connects all selected circuits to the headquarters' circuit.

- (a) It should be noted that to completely disconnect those busy circuit connections which are only partially desired by the headquarters' station, they must all be initially selected on the applique unit and included in the emergency call.
- (4) Requests for a busy circuit will now receive an answer-back of "LTRS B Z LTRS FIGS BL H". The basic circuitry is described in Section II, 2.a.(10). The substitution of the LS3/ADK sequence selector for the LS3/ADJ selector provides the following:
- (a) opens the shunt across the normally closed "BZ" selector contacts (K6)
 - (b) opens the operating circuit of the BZ relay (K7)
 - (c) inserts normally closed contacts (L22) which open in response to an upper case BL, H character sequence in the holding circuit of the SC relay (L26).

A group call should be preceded by a "FIGS Z", as described in Section II, 2.a.(11), to prevent the transmission of a disconnecting signal in the event a called circuit is busy. As before, the BZBG2 relay is hereby operated. Now, if the called circuit happens to be busy or disabled, the switching package transmits only a "LTRS B Z LTRS" answer-back to the calling station. This is accomplished by having normally closed contacts (9) (M6), now open, of the BZBG2 relay located in one operating circuit of the No. 2 answer-back signal generator and normally closed "BZ" selector contacts (K6) in another. As the busy indicating answer-back is operating, the "BZ" selector contacts open while the second "LTRS" character is being transmitted, thereby disconnecting the signal generator. Any following circuit request received by the selector will again close the "BZ" contacts and re-connect the generator.

- (5) In those cases where a line circuit terminates in the reperforator portion of a reperforator-transmitter set, a means for recognizing an upper case BLANK H character sequence must be provided by the user. One such device consists of function blade contacts and the necessary relay circuitry to open a pair of normally closed contacts as described in the preceding paragraph (2). The schematic wiring diagram in Figure 2 outlines this arrangement (connector designations have been omitted).

- (a) The operation of the BL relay partially completes the operating circuits of the UN and H relays. Normally closed contacts of the H relay are connected to the holding circuit of the reperforator's cross-bar holding magnets within TASP. Upon reception of an upper case BLANK signal, the normally open upper case BLANK contacts in the reperforator close momentarily to complete the operating circuit of the BL relay. In operating, the BL relay completes its holding circuit by means of the common battery return at the normally closed contacts (7) of the UN relay and the normally open contacts (12), now closed, of the BL relay. Since the normally open auxiliary contacts in the reperforator close after the upper case BLANK contacts and re-open before these function contacts return to their normal position, the UN relay is prevented from operating during the reception of this signal.
- (b) If the succeeding signal is an upper case H, the normally open upper case H contacts in the reperforator close momentarily to complete the operating circuit of the H relay. In operating, the H relay momentarily opens the reperforator's cross-bar holding magnet circuit within TASP, thereby disconnecting its line circuit from any network connection. Since the upper case BLANK contacts in the reperforator are not operated, the operating circuit of the UN relay is completed by the auxiliary contacts. In operating, the UN relay completes its holding circuit by means of the common battery return at the normally open contacts (11), now closed, of the BL relay and the normally open contacts (12), now closed, of the UN relay. The operation of the UN relay opens the holding circuit of the BL relay which restores to its un-operated position, thereby also opening the holding circuit of the UN relay. Thus, the BL relay will restore to its un-operated position upon reception of any signal other than another upper case BLANK.
- e. As stated in Section II, l.c., the stunt box arrangement determines the character sequences which are the circuit call directing codes. Any two character sequence may be used providing the first character is the same in all instances. However, first characters such as LETTERS, V, M, O and T and also G, A, B and Z should be avoided since they are employed in the answer-back mechanisms. The arrangement furnished with the LS3/ADJ or LS3/ADK sequence selector/stunt box is as follows:

<u>Circuit No.</u>	<u>Call Directing Code</u>	<u>Function Bar in LS3/ADJ or LS3/ADK</u>	<u>Slot No.</u>
1 (SPHQ)	XA	A (Print Condition)	5
2	XB	B " "	6
3	XC	C " "	7
4	XD	D " "	8
5	XE	E " "	9
6	XF	F " "	10
7	XG	G " "	11
8	XH	H " "	12
9	XI	I " "	15

<u>Circuit No.</u>	<u>Call Directing Code</u>	<u>Function Bar in LS3/ADJ or LS3/ADK</u>	<u>Slot No.</u>
10	XJ	J (Print Condition)	16
11	XK	K "	17
12	XL	L "	18
13	XM	M "	19
14	XN	N "	20
15	XO	O "	21
16	XP	P "	22
17	XQ	Q "	36
18	XR	R "	37
19	XS	S "	38
20	XT	T "	39

As an example, if it is desired to change the call directing code of circuit No. 6 from XF to XW, a W (print condition) function bar must be installed in slot No. 10 of the stunt box.

The X (no restrictions) first character function bar is located in slot No. 14. If it is desired to change this function bar in the LS3/ADK unit, the X (no restrictions) function bar in slot No. 3 must also be changed accordingly. The LS3/ADJ unit does not require a function bar in slot No. 3.

LOCATION OF OTHER STUNT BOX CONTACTS

<u>Type</u>	<u>Function Bar in LS3/ADJ or LS3/ADK</u>	<u>Slot Number</u>
B, Z Sequence	B (No restrictions)	1
	Z (No restrictions)	2
FIGS, G Sequence	FIGS (No restrictions)	23
	G (" ")	24
CR, LF Sequence	CR (No restrictions)	31 (old arrg't), 25 (new arrg't)
	LF (" ")	32 (" "), 26 (" ")
FIGS, Z Sequence	FIGS (No restrictions)	28
	Z (" ")	29 and 30

Function Bar in LS3/ADK Only

UC, BL, H Sequence	LTRS (No restrictions)	32
	FIGS " "	33
	BL " "	34
	H " "	35

f. Circuit modifications to permit RT set control in the immediate area of the switching package are also accomplished by means of wire strapping changes on the terminal board panel located at the top rear side of the 165802 line circuit panel cabinet and on the RT terminal strips located on the rear side of each line circuit panel. (Refer to wiring diagram 4451WD.) These modifications merely facilitate the termination of certain line circuits in the transmitter portion of a reperforator-transmitter set. The actual control circuitry must be provided externally to the switching package and connected to the package by means of the terminal board panel. Any line circuit, except No. 1, which is reserved for selective emergency calls, may be modified for RT set control.

(1) Make the following wire strapping changes on the RT terminal strip of the line circuit intended for RT set input:

(a) Move the black-green wire lead from terminal No. 1 to terminal No. 2.

1. This change prevents grounding of the LB relay driver within the switching package and completes a circuit for doing so externally by means of the RTC terminal strip on the terminal board panel.

(2) Since the RT set transmitting line circuit cannot receive outside calls, it is not normally assigned a circuit address. Therefore, the following change must be made on the terminal board panel:

(a) Remove the wire strap between the associated LS and SR terminal strips of the RT circuit.

(3) In those special cases where it is desired to make an automatic call from the RT set transmitter to a monitor printer on the same line a circuit address must be employed. It should be noted that all transmission must emanate only from the RT set transmitter. The following wire strapping changes must also be made on the terminal board panel: (Use #24 or larger gauge wire.)

(a) Add a wire strap between LS - (RT) and XH - (RT).

(b) Add a wire strap between XH - (RT) and BLB - (RT).

(c) Add a wire strap between BLA - (RT) and SR - (RT).

1. These changes make the RT set transmitting line circuit momentarily busy while it is being inadvertently called by another line circuit and results in the transmission of the busy indicating answer-back to that circuit.

- (4) To prevent the RT set circuit or for that matter any particular circuit from being erroneously included in an emergency call, the handle of its associated NORMAL-CALL key on the 165985 manual switch panel should be removed and replaced by a 119641AA plug button.
- (5) One method of controlling the transmitter portion of an RT set to provide automatic tape transmission from the RT set sending line circuit to any other particular line in the TASP network is outlined in the schematic wiring diagram of Figure 3. This method is applicable only to those systems which employ the special upper case Blank H signal as the circuit disconnecting code. It consists of relay circuitry, which controls the operation of the sensing and distributor clutch magnets of the RT set, and a sequence selector (LS) unit which responds to the transmitter-distributor line signals of the RT set, and, in turn, controls the operation of the relay circuitry. The transmitter-distributor signal line is connected to the LS selector magnet by means of an RY30 line relay and also to the desired line circuit terminals of TASP.
- (a) This is only a two-circuit calling system from the RT set circuit to any other circuit in the TASP network. Also, it is a single message system, i.e. the circuits are released after each message. The elements of a message are as follows:
1. Circuit address - Double circuit call directing code such as XAXA or XBXB or XCXC, etc.
 2. Station address - (If desired for station selective calling) - any character sequence, usually two in number, except avoid the use of the first character of the circuit CDC, normally X, or sequences GA and BZ which are employed in the answer-back mechanisms.
 3. End-of-Address - Carriage Return Line Feed
 4. Letters and Text of Message
 5. End-of-Message and End of Transmission - Upper Case Blank H Letters
- (b) The basic sequential selector stunt box parts for controlling the transmitter portion of the RT set are indicated on the following pages:

BASIC SEQUENTIAL SELECTOR STUNT BOX PARTS FOR RT SET CONTROL

SLOT NO.	PAWL NO.	FUNCTION BAR NO.	DESCRIPTION	LEVER NO.	RELEASE STUD NO.	LATCH NO.	CONTACT BLOCK NO.	CONTACT PLATE NO.	CONTACT ARM NO.
1	152653	155106	G, SELECT	152121	-	154613	172597	172596	-
2	"	155100	A, SELECT	152298	-	"			157887
3	"	152665	LTRS. NO RES.	153670	152357	152660			-
4	"	152666	FIGS, NO RES.	152121	-	152089			-
5	"	152669	BL, NO RES.	153670	165914	152660	172597	172595	-
6	"	152667	CR, NO RES.	152121	-	154613			-
7	"	152668	LF, NO RES.	152298	-	152089			157887
8	"	152665	LTRS, NO RES.	153670	152357	152660			-
9	"	152666	FIGS, NO RES.	152121	-	152089	172597	172594	-
10	"	152669	BL, NO RES.	157207	-	154613			157899
11	153604	152683	H, NO RES.	157206	-	152660			157899
12	-	-	-	153670	165914	152660			157887
13	152653	152667	CR, NO RES.	152121	-	154613	-	-	-
14	152653	152668	LF, NO RES.	152298	-	152089	(SEE NOTE NO. 1)	-	-
15	-	-	-	-	-	-	172597	172595	-
16	-	-	-	-	-	-			-
17	152653	153440	A, PRINT SELECT	152298	-	154613			157887
18	152653	"	UNIV, PRINT SELECT	153670	165914	152660			157887

BASIC SEQUENTIAL SELECTOR STUNT BOX PARTS FOR RT SET CONTROL

SLOT NO.	PAML NO.	FUNCTION BAR NO.	DESCRIPTION	LEVER NO.	RELEASE STUD NO.	LATCH NO.	CONTACT BLOCK NO.	CONTACT PLATE NO.	CONTACT ARM NO.
19	-	-	-	-	-	-	-	-	-
20	152653	153440	X, SELECT	152298	-	152089	172597 (SEE NOTE NO. 2)	172594	157887
21	"	"	B, PRINT SELECT	"	-	154613	172597	172594	157887
22	"	"	C, "	"	-	"	↓	↓	"
23	"	"	D, "	"	-	"	↓	↓	"
24	"	"	E, "	"	-	"	↓	↓	"
25	"	"	F, "	"	-	"	172597	172594	"
26	"	"	G, "	"	-	"	↓	↓	"
27	"	"	H, "	"	-	"	↓	↓	"
28	"	"	I, "	"	-	"	↓	↓	"
29	"	"	J, "	"	-	"	172597	172594	"
30	"	"	K, "	"	-	"	↓	↓	"
31	"	"	L, "	"	-	"	↓	↓	"
32	"	"	M, "	"	-	"	↓	↓	"
33	"	"	N, "	"	-	"	172597	172594	"
34	"	"	O, "	"	-	"	↓	↓	"
35	"	"	P, "	"	-	"	↓	↓	"
36	"	"	Q, "	"	-	"	↓	↓	"

- (c) With the initial application of power, the following operating conditions may be observed in the relay circuitry:

- RT - RT set operating relay de-energized
- TSD - Transmitter start delay relay de-energized
- TSP - Transmitter stop relay, de-energized
- TPG - Transmitter pulse generating relay de-energized
- PGD - Pulse generating delay relay energized
- TR - TASP ready relay de-energized
- TRDI - TASP ready delay relay No. 1 energized
- TRD2 - TASP ready delay relay No. 2 energized
- B - Sequence selector blinding relay de-energized
- AL - Alarm relay de-energized

- (d) An ON-OFF switch, which stops tape transmission immediately, and an EOM switch, which stops tape transmission only at the end-of-message, are placed in the ON position to start the transmitter portion of the RT set. The operating circuit of the RT relay is then completed by means of common battery return through the EOM switch, the normally closed contacts (7) of the TSP relay and the normally closed contacts (7) of the TSD relay to the upper terminal U of the RT relay. In operating, the RT relay completes its holding circuit from common battery return in the RT set relay panel to the normally closed upper case Blank H sequence contacts and the normally closed X UNIVERSAL sequence contacts in the selector unit to the normally open contacts (5), now closed, of the RT relay and to the upper terminal U of the RT relay.
- (e) The operation of the RT relay completes the operating circuit of the TSD relay which may be traced from common battery return at the normally open contacts (1), now closed, of the RT relay to the upper terminal U of the TSD relay. In operating, the TSD relay completes its holding circuit from common battery return at the normally closed contacts (9) of the TSP relay to the normally open contacts (10), now closed, of the TSD relay and to the upper terminal U of the TSD relay. The operation of the TSD relay by means of its normally closed contacts (7), now open, also opens the operating circuit of the RT relay.
- (f) With a message tape ready for transmission in the transmitter portion of the RT set, its normally open transmitter-stop contacts are closed and the operation of the RT relay completes the operating circuit of the sensing clutch magnet. This circuit may be traced from common battery return at the transmitter-stop contacts to the normally open contacts (2), now closed, of the RT relay, through the ON-OFF switch to normally closed contacts (7) of the TPG relay to the sensing clutch magnet.

- (g) The operation of the RT relay also completes the operating circuit of the TPG relay which may be traced from common battery return through the normally open contacts (2), now closed, of the RT relay, through the ON-OFF switch to the normally closed Carriage Return Line Feed sequence contacts in the sequence selector, the normally open contacts (10), now closed, of the PGD relay to the upper terminal U of the TPG relay. In operating, the TPG relay opens the operating circuit of the sensing clutch magnet thereby stopping tape sensing after the first character, normally X. The distributor clutch contacts, operated by the sensing cam assembly, close momentarily to operate the distributor clutch magnet. Thus, the first character is transmitted on the signal line where it is received by the sequence selector through its associated line relay. The operation of the TPG relay also completes its own holding circuit from common battery return at the normally open contacts (2), now closed, of the PGD relay to the normally open contacts (2), now closed, of the TPG relay and to the upper terminal U of the TPG relay.
- (h) In operating, the TPG relay opens the operating circuit of the PGD relay by means of its normally closed contacts (9), now open. After slowly releasing, the PGD relay opens the operating and holding circuits of the TPG relay. After also slowly releasing, the TPG relay again completes the operating circuit of the sensing clutch magnet and the PGD relay. In operating, the PGD relay completes the operating circuit of the TPG relay. The TPG relay again operates to open the operating circuit of the sensing clutch magnet, thereby stopping tape sensing after the second character of the circuit address.
- (i) The second character is recognized by the sequence selector which momentarily opens its normally closed X UNIVERSAL sequence contacts in the holding circuit of the RT relay. The RT relay releases and further opens the operating circuit of the sensing clutch magnet and also of the TPG relay. The transmitter portion of the RT set will now remain idle until a GA character sequence is received by the sequence selector.
- (j) In addition to operating the X UNIVERSAL sequence contacts, the sequence selector also closes the normally open contacts which correspond to the circuit address. If that particular line circuit is idle its associated X relay within the switching package will be de-energized as indicated by its normally closed contacts (9) which terminate at the terminal board panel. The operating circuit of the TR relay is thereby completed. It may be traced from common battery return of the RT set relay panel to the RTA-1 terminal of TASP, through the switching package at its open line disable panel CCOLP connector at LC2-U13, the normally closed contacts (20, 19) of the NORMAL-DISABLE key of the desired circuit, the associated CCOLP panel connector LC2 terminal, the corresponding LP connector at terminal r, the normally closed contacts (9) of the X relay, the LP connector at terminal s, the associated RTB terminal, and out of the switching package into

the RT set sequence selector at its normally open contacts, now closed, which correspond to the circuit address, and back to TASP at its LDC terminal associated with the RT set transmitting line, through the switching package via its corresponding CCOLP panel connector LC2 terminal, the normally closed contacts (10,11) of the NORMAL-DISABLE key of the RT set circuit, the associated CCOLP panel connector LC2 terminal, the associated LDB terminal, and out of the switching package to the RT set relay panel at the upper terminal U of the TR relay.

- (k) When the selector portion of the switching package is idle, the operation of the TR relay completes the operating circuit of the B relay. This circuit may be traced from common battery return at the ST-1 terminal in TASP to the RT set relay panel at the normally open contacts (10), now closed, of the TR relay through the diode to the upper terminal U of the B relay. The operation of the B relay, by virtue of its normally open contacts (12), now closed, completes an electrical shunt across the marking contacts of the line relay associated with the sequence selector. The operation of the B relay, by means of its normally closed contacts (7), now open, also opens the operating circuit of the TRD1 relay. The TRD1 relay slowly releases and then by means of its normally open contacts (10) it also opens the operating circuit of the TRD2 relay. After slowly releasing, the TRD2 relay completes the circuit for the application of common battery return potential to terminal R of the electronic driver associated with the LB relay of the RT set transmitting line. This circuit may be traced from common battery return at the normally open contacts (8), now closed, of the TR relay to the normally open contacts (10), now closed, of the B relay through the normally closed contacts (5) of the TRD2 relay to the RTC terminal in TASP which is connected to terminal R of the electronic driver. The driver output is cut-off and the operating winding of the LB line relay is de-energized causing an open-line condition. As before, this is recognized by the switching package as a bid for a path from the RT set transmitting line and the selector portion of TASP is subsequently connected to it.
- (1) With the RT set transmitting line connected to the selector portion of TASP, common battery return is removed from the ST-1 terminal and the B relay is de-energized. The electrical shunt is removed from the marking contacts of the line relay associated with the sequence selector, the TRD1 and TRD2 relays are again energized, and common battery return potential is removed from terminal R of the electronic driver associated with the LB relay of the RT set transmitting line. As previously described in Section II, 2.a.(5), a "GA" answer-back is then transmitted by TASP to the RT set transmitting line where it is received by the **sequence selector.**

- (m) The reception of the first "GA" from TASP by the sequence selector releases the circuit address contacts thereby opening the operating circuit of the TR relay. The sequence selector also responds to the "GA" sequence by closing normally open contacts which are located in a second operating circuit of the RT relay. This circuit may be traced from common battery return in the RT set relay panel to the normally open "GA" contacts, now closed, in the sequence selector to the upper terminal U of the RT relay. In operating, the RT relay again completes its holding circuit and the operating circuits of the sensing clutch magnet and TPG relay. The events described in the preceding paragraphs (g)(h) and (i) are repeated.
- (n) As a result of the second transmission of the circuit address the normally open contacts which correspond to them are closed in both the RT set and TASP sequence selectors. As before, the TR relay is again energized but this time it has no purpose. However, the selector within TASP functions as described in Section II, 2.a.(8) to connect the desired line circuit to the RT set transmitting line. The second "GA" answer-back is transmitted by TASP and again received by the RT set sequence selector. As a result, the RT relay is again operated and the RT set resumes transmission on a single character pulsing basis until the end of address, CR LF, is transmitted.
- (o) When the end of address, CR LF, is received by the TASP sequence selector, the RT set transmitting line is disconnected from the selector portion of the switching package as described in Section II, 2.a.(6)(e). The end of address code is also received by the RT set sequence selector where it opens the normally closed CARRIAGE RETURN LINE FEED sequence contacts located in the operating circuit of the TPG relay. The TPG relay become inoperative and disables the transmitter pulse generating circuit which results in the sensing clutch magnet being continuously energized. Thereafter, tape transmission of the message text continues at geared speed until the CARRIAGE RETURN LINE FEED sequence contacts within the RT set selector are again closed as a result of receiving an upper case BLANK signal. The LETTERS character preceding the message text merely assures its reception in lower case characters.
- (p) The reception of an upper case BLANK signal by the RT set sequence selector returns tape transmission to a single character pulsing basis, thereby enabling transmission to stop, and circuit disconnecting to occur following transmission of the LETTERS character in the upper case BLANK H LETTERS end of message sequence. The CARRIAGE RETURN LINE FEED sequence contacts are re-closed during the transmission of the H character and the sensing of the LETTERS character. The TPG relay operates to open the sensing clutch magnet circuit. The upper case BLANK H sequence contacts operate during the transmission of the LETTERS character to momentarily open the holding circuit of the RT relay which releases and opens

the operating circuit of the TPG and TSD relays and further opens the operating circuit of the sensing clutch magnet. Meanwhile, another pair of upper case Blank H sequence contacts operate to momentarily complete the operating circuit of the TSP relay. This circuit may be traced from common battery return in the RT set relay panel to the normally open upper case BLANK H contacts, now momentarily closed, in the sequence selector to the upper terminal U of the TSP relay. In operating, the TSP relay completes its holding circuit which may be traced from common battery return at the normally open contacts (8), now closed, of the TSD relay, to the normally open contacts (12), now closed, of the TSP relay and to the upper terminal U of the TSP relay. The operation of the TSP relay by means of its normally closed contacts (9), now open, also opens the holding circuit of the TSD relay. The TSD relay slowly releases and opens the holding circuit of the TSP relay. While the TSP relay is thus being energized and subsequently released, a third pair of normally closed upper case BLANK H sequence contacts operate to momentarily open the holding circuit of the cross-bar holding magnets of the RT set transmitting line within TASP. (Refer to Section III, 2.d.). The release of the TSD and TSP relays return the relay circuitry to its starting condition.

- (q) In the event tape transmission starts but is not completed in approximately 3-1/2 minutes, an alarm circuit has been provided for the operation of external indicators. The AL relay under the control of electron tube T provides this function. In addition, it is recommended that an auxiliary printer (not shown) be connected to the RT set transmitting line by means of an RY30 line relay and controlled by a marking contact "blinding" switch which would normally prevent signal reception. Since tape transmission is most likely to be interrupted by an incorrect address or a request for a continuously busy or disabled line circuit, an emergency start non-locking key has been provided. Should transmission thus be stopped for a prohibitive length of time it is suggested that (1) the NORMAL-DISABLE key associated with the RT transmitting line be placed in a DISABLED position, (2) the auxiliary printer blinding switch be placed in the open position and (3) the emergency start key be momentarily depressed until transmission is resumed. In this manner, the offending message will be recorded on the auxiliary printer for later transmission. The message tape will automatically stop at the end of message with the first portion of the succeeding circuit address also being recorded, but disregarded, on the auxiliary printer. To resume normal tape transmission the blinding switch for the auxiliary printer should be placed in the closed position and the RT set NORMAL-DISABLE key returned to the NORMAL POSITION.

- g. Circuit modifications to permit the operation of only ten (10) or less line circuits with only one cross bar switch are accomplished by connecting two dummy plugs to the 165801 cabinet receptacles associated with the absent cross bar switches. In this case, the LXB cross bar switch is the only one required. Dummy plugs are connected to the receptacles of the absent 1AXB and 2XB switches. No plug is required for the 2AXB switch. (Refer to wiring diagram 4451WD).

- (1) Since the associated selecting magnets of the 1AXB and LXB cross bar switches are normally connected in series, the 165853 dummy plug for the 1AXB cross bar switch completes the circuit for the selecting magnets of the remaining LXB switch. Its terminal points are strapped as follows:

A3 to A5	B8 to B10
A7 to A9	B12 to B14
A11 to A13	C1 to C3
A15 to B2	C5 to C7
B4 to B6	C9 to C11

- (a) There is also a toggle switch marked 20 CKT - 10 CKT associated with the selecting magnets of the cross bar switches. It is located on the answer-back control panel directly beneath the LXB switch. When only the LXB cross-bar switch is used in the cabinet, the toggle switch must be placed in the 10 CKT position. This inserts a 50 ohm resistor in the selecting magnet circuit replacing the load of the absent magnets. When all four cross bar switches (for 20 line circuits) are used, the toggle switch must be placed in the 20 CKT position which shunts the 50 ohm resistor.

- (2) Since the associated holding magnets of the 2XB and LXB cross bar switches are normally connected in series, the 165854 dummy plug for the 2XB cross bar switch completes the circuit for the holding magnets of the remaining LXB switch. Its terminal points are strapped as follows:

C13 to C15	E3 to E5
D2 to D4	E7 to E9
D6 to D8	E11 to E13
D10 to D12	E15 to F2
D14 to E1	F4 to F6

- (a) A substitute load resistor is not required for the holding magnets.

- h. Circuit modifications to permit the elimination of the selective emergency calling feature and the associated manual switch panel are accomplished by connecting a dummy plug to the AP connector in the 165802 cabinet. (Refer to wiring diagram 4451WD.)
- (1) By referring to Section II, 2.a.(12) it may be observed that the emergency calling feature can be disabled by (1) disconnecting the manual switch panel from its AP connector in the 165802 cabinet, (2) applying common battery return to the holding circuits of the cross-bar holding magnets at the associated AP connector terminals, (3) applying common battery return to the common holding circuit of the SC relays at the appropriate AP connector terminal, and (4) shunting the headquarter's NORMAL-HOLD key at its AP connector terminals. Since the associated BUSY lamps of the manual switch panel and open line disable panel are normally connected in series, the dummy plug must also complete the circuit for the BUSY lamps in the remaining open line disable panel. Accordingly, the 165859 dummy plug for the AP connector has its terminal points strapped as follows:
- U13 to K2 to K4 to F8 to F6 to F4 to F2 to E1 to E3 to E5 to
E7 to E9 to E11 to E13 to E15 to D14 to D12 to D10 to D8 to
D6 to D4 to D2 .
- K12 to K14 .
- U9 to O10 to O8 to O6 to O4 to O2 to N1 to N3 to N5 to N7 to
N9 to N11 to N13 to N15 to M14 to M12 to M10 to M8 to M6 to
M4 to M2 .
- (a) To provide longer life, the twenty BUSY lamps in the open line disable panel at the front of the 165802 cabinet must be changed from the normal 165121 (K2 - 30V.) to 79152 (2Y-48V.).
- (b) The elimination of the emergency calling feature obviates the transmission of a "GA" answer-back in response to the FIGS G emergency calling code. To prevent this answer-back a 157274 clip must be used to disable the G function pawl in slot 24 of the sequence selector within TASP.

3. LUBRICATION

- a. The 28 Type Sequence Selector is lubricated in accordance with Bulletin 217B.
- b. The 28 Type Sequence Selector Motor drive unit is lubricated in accordance with Bulletin 217B, section 3, page 8.
- c. The Multiple Wire Distributor is lubricated in accordance with Specification 6434S.
- d. The 28 Type Sequence Selector Base assembly is lubricated in accordance with Specification 60,179S.
- e. The 164129 set of common answer-back parts is included with the 28 Type Sequence Selector Base. It is lubricated in accordance with Specification 6924S.
- f. The Universal Contact Modification Kit for the Sequence Selector is lubricated in accordance with Specification 60,178S.

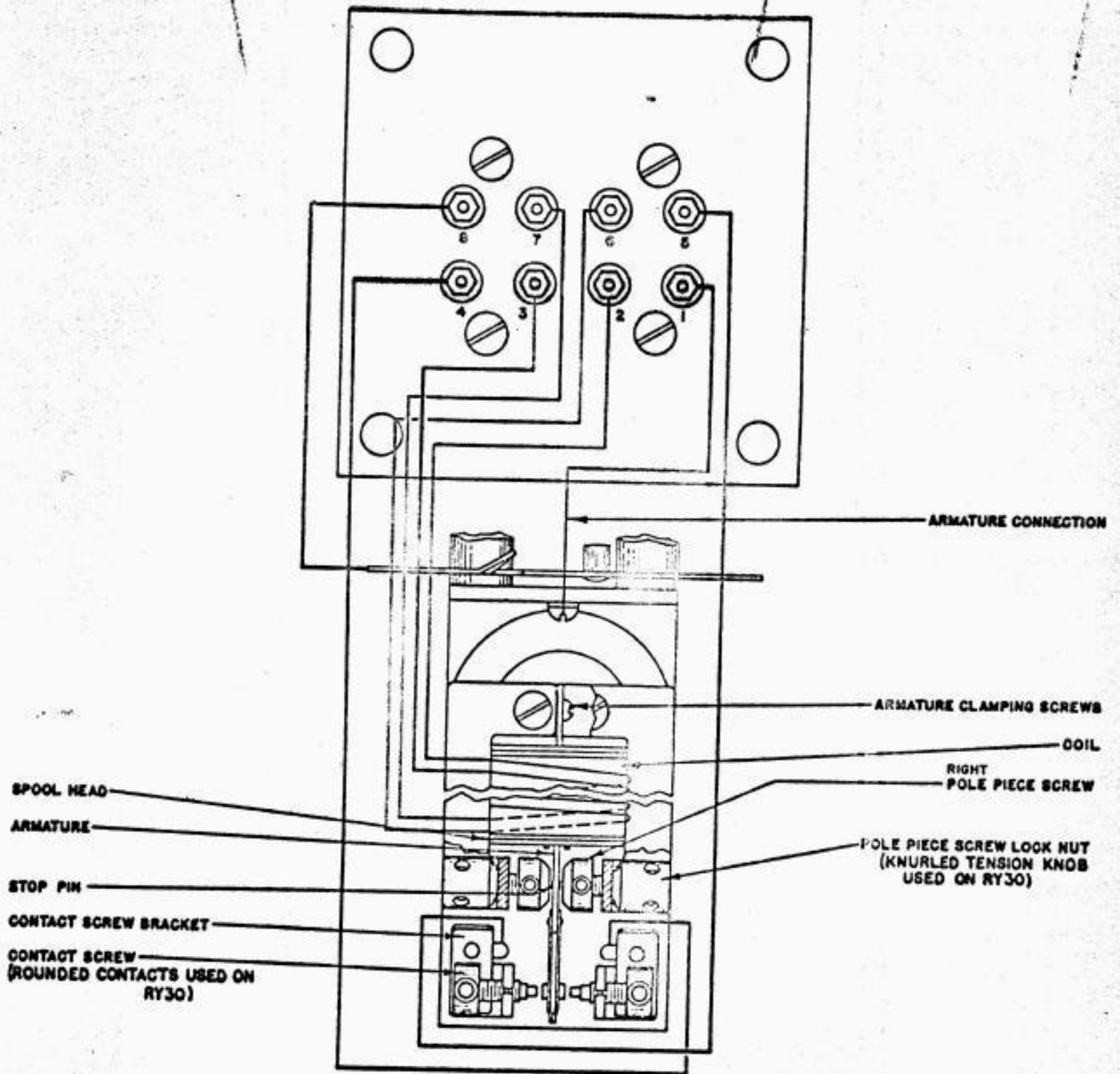
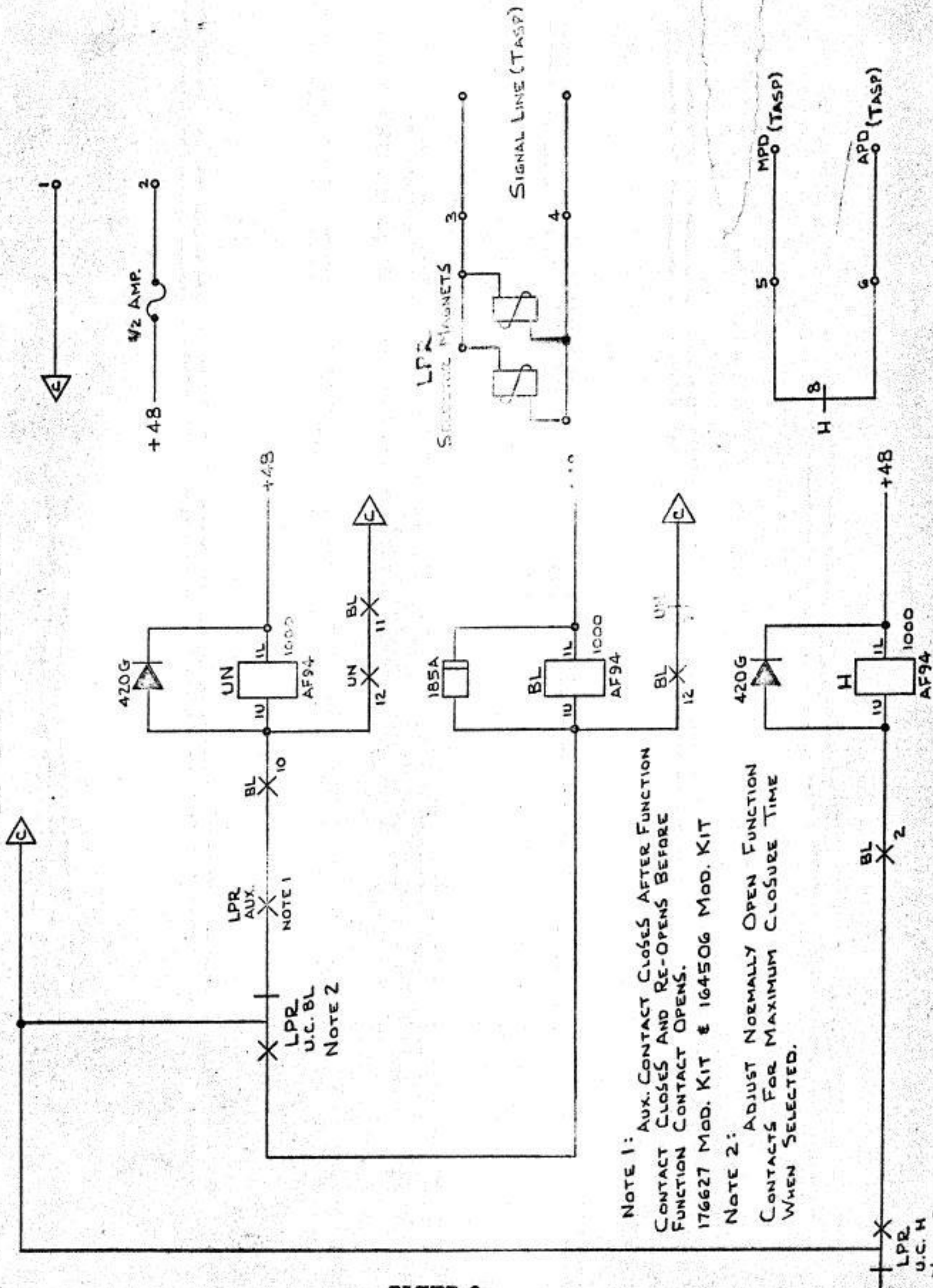

FIGURE 1

RECOGNITION OF UPPER CASE BLANK - H SEQUENCE
ON LPR REPERFORATOR



NOTE 1: AUX. CONTACT CLOSÉS AFTER FUNCTION CONTACT CLOSÉS AND RE-OPENS BEFORE FUNCTION CONTACT OPENS.
176627 MOD. KIT & 164506 MOD. KIT

NOTE 2: ADJUST NORMALLY OPEN FUNCTION CONTACTS FOR MAXIMUM CLOSURE TIME WHEN SELECTED.

FIGURE 2

LPR
U.C. BL
NOTE 2

SECTION IV

MANUFACTURING INFORMATION

1. GENERAL

- a. The units shall be manufactured in accordance with released prints, bills of material and engineering specifications.
- b. The units shall withstand a 500 volt D.C. breakdown test between the terminals and frame.
- c. All screws and nuts shall be tight and free from burrs. Springs shall be securely anchored.
- d. The finish shall be free from cracks, scratches, blisters and corrosion.
- e. All soldered connections shall be tight, free from corrosion and shall not interfere with any moving parts.
- f. All moving parts shall be free from binds.
- g. The wiring shall conform to applicable WD's. (Refer to B/M's.)

SECTION V

INSTALLATION AND SERVICING INSTRUCTIONS

1. INSTALLATION

a. General Instructions

- (1) This equipment is intended for installation at the central office or "headquarters" location.
- (2) Unpack all parts and units with care. Muslin bags and small parts should be kept with their associated pieces of apparatus until used in the installation.
- (3) Before any actual mounting and assembly procedures are followed, determine the exact layout and position of each piece of equipment.

b. Installation of the 165801 Cabinet

This cabinet (as is its associated cabinet 165802) is very large and heavy. It is recommended that its installation take place at its permanent location or at least as near as possible.

(1) Rectifier Power Supplies

At the bottom of cabinet are mounted the two rectifier power supplies. They are packed in separate crates. The REC56 is the +120 volt supply and mounts on the bottom. The REC55 is the -40 and +48 volt supply and is mounted just above the REC56.

(a) Mechanical Installation

1. Remove unit from its crate, taking care to retain any muslin bags, wiring diagrams, etc.
2. Remove cover from unit by turning the two fasteners at the back a quarter turn. Remove all packing material which may be inside the unit.
3. From the rear of the cabinet, mount the REC56 unit to the cabinet rack mounting frame approximately 1-1/2" above the base plate by means of the screws included with the cabinet.
4. Similarly mount the REC55 unit to the mounting frame just above the first rectifier unit allowing approximately 1/4" clearance between the two.

(b) Electrical Installation

1. Connect and route the REC56 power input cord, furnished with the cabinet, from the lowest outlet of the power plug-

in strip through the lower rear bushing on the left side of the rectifier. Connect the black wire lead from the power cord to the ungrounded side input terminal (AC IN +) of the rectifier. Connect the white wire lead from the power cord to the grounded side input terminal (AC IN G) of the rectifier. Connect the green wire lead from the power cord to the frame ground terminal (FR GRD) of the rectifier.

2. Connect and route the REC55 power input cord, furnished with the cabinet, from the second lowest outlet of the power plug-in strip through the lower rear bushing on the left side of the rectifier. Connect its power cord leads similarly to that of the REC56 rectifier.
3. Connect the power input cord at the top of the plug-in strip to the receptacle in the power distribution panel at the top of the cabinet. Route the power input cord from the power distribution panel out of the cabinet by means of a rectangular opening at its top and connect it to a 115 volt, 60 cycle, 15 ampere, single phase, power source. Place the ON-OFF toggle switch on the front of the power distribution panel in the ON position.
4. The NO LOAD voltage output of the REC56 rectifier should be adjusted as close as possible to 128 volts DC. Adjust the output by moving the wire strap which connects terminal 8 to terminal 4, 5, or 6. Do not remove the wire strap from terminal 8. Connecting terminal 8 to terminal 4, 5 or 6 provides a LOW, MEDIUM or HIGH output, respectively. (Refer to the schematic wiring diagram on the inside of the cover.)
5. The NO LOAD voltage outputs of the REC55 rectifier should be adjusted as close as possible to 50 volts D.C. for the 48 volt supply and 45 volts D.C. for the 40 volt supply. (Refer to the schematic wiring diagram on the inside of the cover.)
 - a. Adjust the output of the 48 volt supply by moving the GREEN and YELLOW wire leads from the L (LOW), M (MEDIUM) or H (HIGH) terminals as required. Keep the GREEN conductor on the upper L, M or H terminal and the YELLOW conductor on the corresponding lower L, M or H terminal.
 - b. Adjust the output of the 40 volt supply by moving the ORANGE and SLATE wire leads from the same L, M or H terminal as required. Keep the ORANGE conductor on the upper L, M or H terminal and the SLATE conductor on the corresponding lower L, M or H terminal.

6. Place the ON-OFF toggle switch on the front of the power distribution panel in the OFF position and remove the associated power input cord from its 115 volt AC power source.
 7. Route the long 14 gauge wire strap, furnished with the cabinet, from the lower REC56 rectifier through the upper front knock-out hole on the left side and into the lower front knock-out hole on the left side of the upper REC55 rectifier. Connect the wire strap from the 120V DC negative output terminal (DC -) in the REC56 rectifier to the 40 VDC positive output terminal (40V +) in the REC55 rectifier.
 8. Connect the short 14 gauge wire strap, furnished with the cabinet, from the 40V DC positive output terminal (40V +) to the 48V DC negative output terminal (48V -) in the REC55 rectifier.
 9. Route the black and white leads from the cable leading to the fuse and alarm panel through the upper rear bushing on the left side of the REC56 rectifier. Connect the black wire lead to the 120 VDC negative output terminal (DC -) and the white wire lead to the 120V DC positive output terminal (DC +).
 10. Route the red and green leads from the cable leading to the fuse and alarm panel through the upper rear bushing on the left side of the REC55 rectifier. Connect the red wire lead to the 48V DC positive output terminal (48V +) and the green wire lead to the 40V DC negative output terminal (40V -). Replace the rectifier covers.
- (2) Model 28 Sequence Selector (LS), Base (LSB), Distributor (LD) and Motor (LMU)
- (a) These units may or may not be assembled and packaged together. If they are furnished separately, they must be assembled before they are placed within the cabinet. Refer to the specifications included with this equipment for the necessary instructions and adjustments.
 - (b) The shelf and cover assembly for this equipment is mounted in the cabinet when received. The cover will be tied to the cabinet and must be removed from the rear before equipment installation. Install the assembled equipment on the shelf so that the base rests in the well formed by the felt pad lining with the three connectors toward the front of the cabinet.

- (c) Connect the S connector to the sequence selector, the LD connector to the distributor and the F connector to the base. Make certain that the associated power input cord is connected to a convenient receptacle in the power plug-in strip.
- (d) Replace the cover over the equipment so that it rests on the felt pads within the shelf.

(3) Cross-Bar Switch Assembly

Each assembly is mounted to three plates located on the cabinet rack mounting frame by means of six #12-24 x 1/2" screws inserted through mounting holes on each side of the switch. The screws are furnished with the cabinet. The assemblies are installed from the rear of the cabinet in the following order, from the bottom up; 1XB, 2XB, 1AXB, 2AXB. The 1XB cross-bar switch should be mounted approximately 3/8" above the answer-back control panel. Thereafter, the clearance between adjacent switches should be approximately 1/4". When all assemblies are securely fastened, the switch connectors should be installed in their associated mating connectors. Fasten the connectors only finger tight.

- (a) There is a toggle switch marked 20 CKT - 10 CKT associated with the cross-bar switch assemblies. It is located on the answer-back control panel. When only one cross-bar switch (1XB for 10 line circuits) is installed in the cabinet the toggle switch must be placed in the 10 CKT position. When all four cross-bar switches (for 20 line circuits) are installed in the cabinet the toggle switch must be placed in the 20 CKT position.
- (b) When the 1XB cross-bar switch is the only one installed, a 165853 and a 165854 dummy plug must be connected to the 1AXB and 2XB cabinet connectors, respectively. Refer to Section III, 2.g.

(4) RY30 (W.E. 255-A) Relay

There is one RY30 relay (LS) used in this cabinet. It is to be installed in the answer-back control panel. Before placing it in its socket it should be adjusted in accordance with Section III, 2. of this specification.

(5) Electronic Driver Assembly

The electronic driver is a printed circuit card assembly used in conjunction with the RY30 relay (LS) in the answer-back control panel. This unit is furnished with the answer-back control panel. It does not require adjustment. Make certain that it is fully inserted in its associated connector (D) with the card components on the top side.

(6) Cable Assemblies

- (a) The cable and connector marked PAL from the power distribution relay panel, located at the top of the cabinet rack mounting frame, should be connected to its mating connector on the back of the power distribution panel located at the top front side of the cabinet. This connection is accessible from the front of the cabinet.
- (b) The cable and connector marked PAR from the right side of the fuse and alarm panel on the front of the cabinet should be connected to its mating connector on the power distribution relay panel which is accessible from the rear of the cabinet. Route the cable along the right side of the cabinet and over the top of the power distribution relay panel.
- (c) The cable and connector marked PL from the right side of the fuse and alarm panel should be connected to its mating connector on the upper right side of the cabinet. This connection is accessible from the front of the cabinet.
- (d) The cable and connector marked AB from the answer-back control panel should be connected to its mating connector on the right side of the cabinet. This connection is accessible from the front of the cabinet.

c. Installation of the 165802 Cabinet

To enable the 165801 cabinet to be inter-connected with the 165802 cabinet, the right side of the 165802 cabinet must be located within two feet of the left side of the 165801 cabinet.

(1) Line Circuit Panels

Each line panel is mounted to four studs located on the cabinet rack mounting frame by means of four #12-24 x 1/2" screws inserted through mounting holes on each side of the panel. The screws are furnished with the cabinet. The panels are installed from the rear of the cabinet, from the top down.

- (a) When a full complement of line circuit panels (10 for 20 line circuits) are to be installed in the cabinet, the top two mounting studs to be used should be located 1-1/2" from the bottom of the common control relay panel, one on each side of the rack. Thereafter, the mounting studs should be located in the rack mounting holes located 3" apart.
- (b) When less than 10 panels are to be installed in the cabinet, the top two mounting studs to be used should be located 7-1/2" from the bottom of the common control relay panel, one on each side of the rack. Thereafter, the mounting studs should be located in the rack mounting holes located 3" apart.

- (c) Before mounting the top line circuit panel in a 10 panel cabinet, the four RY30 relays (two LA & two LB) associated with it must be installed. Make certain that each relay has been adjusted in accordance with Section III.2. of this specification.
- (d) Install each line circuit panel from the rear of the cabinet with the relays toward the front and the connecting cables toward the bottom. Fasten each panel to the associated four mounting studs by means of the four screws and mounting holes located toward the center of the panel.
- (e) Install the line circuit panel connectors in the cabinet LP connectors associated with the line circuits they are to control. If the 165985 manual control panel which provides the emergency call feature is to be employed with this equipment, one line circuit panel connector must be installed in the LP1 cabinet connector. These connections are accessible from the front of the cabinet. Fasten the connectors only finger tight.
- (f) There is a toggle switch marked ON-OFF associated with each LP connector in the cabinet. With a line circuit panel connected to a particular LP cabinet connector its toggle switch must be placed in the ON position. LP cabinet connectors not in use must have their toggle switches placed in the OFF position.
- (g) There are two electronic driver assemblies furnished with each line circuit panel. Each is a printed circuit card assembly used in conjunction with the LB RY30 relay in each line circuit. Insert a circuit card in the socket type connector located on each side at the rear of the panel. The components on each circuit card should face away from the panel. A plastic cover plate is supplied for each card and is used to protect and align the card in its connector.
 1. Remove the existing mounting screws, lockwashers and washers located in the card connector mounting bracket.
 2. Fit the end of the card opposite the connector into the notch in the post on the plastic cover.
 3. Fasten the plastic cover to the connector bracket with the previously removed mounting hardware.

(2) RY30 (W.E. 255-A) Relays

There are four RY30 relays used in each line circuit panel. Before installation they should be adjusted in accordance with Section III. 2. of this specification. After adjustment they are to be mounted in their appropriate sockets marked LA and LB on the panel.

(3) Cable Assemblies

- (a) There are five mating connectors located behind the top front panel of the 165802 cabinet. They are marked CP2, LC3, LC2, LC1 and CP1. Make certain they are properly connected and fastened only finger tight.

(4) Manual Switch Panel for Emergency Calling

This panel assembly is used for emergency calling and should normally be located adjacent to the headquarter's send-receive teletypewriter intended for such use. To facilitate its location, the manual switch panel is suitable for table top installation and is equipped with a 25-foot cable assembly by which it is connected to the 165802 cabinet. The cable assembly should be routed through the rectangular opening on the top left side of the cabinet. Its associated connector is marked AP to which it should be fastened only finger tight.

- (a) When the manual switch panel is not installed, a 165855 dummy plug must be connected to the AP cabinet connector. In addition, the twenty BUSY lamps in the open line disable panel at the front of the 165802 cabinet must be changed from the normal 165121 (K2-30V) to 79152 (2Y-48V). Use an orange stick to remove the BUSY lamp lenses and a piece of 60287RM tubing to remove the 165121 lamps from the sockets. Also, use a 157274 clip to disable the G function pawl in slot 24 of the sequence selector within TASP. Refer to Section III, 2.h.

d. Inter-Cabinet Connections

- (1) The 165801 and 165802 cabinets are inter-connected by means of three cable assemblies. These are (1) the inter-cabinet power cable assembly, (2) the inter-cabinet control cable assembly and (3) the inter-cabinet selector unit cable assembly.

(a) Route the power cable assembly over the tops of the two cabinets so that its connector marked 1P enters the rectangular opening on the top left side of the 165801 cabinet and its connector marked 2P enters the rectangular opening on the top right side of the 165802 cabinet. Fasten the 1P and 2P connectors to their mating connectors within the cabinets only finger tight.

(b) Similarly, route the control cable assembly into the two cabinets and fasten the 1C and 2C connectors to their mating connectors only finger tight.

(c) Also route the selector unit cable assembly into the two cabinets and fasten the 1S and 2S connectors to their mating connectors only finger tight.

- (2) There is an auxiliary connector at the top of each cabinet which is intended for possible future use. No mating connectors are herewith provided. Make certain that the toggle switch associated with the 2 AUX. connectors in the 165802 cabinet is in the OFF position.

e. Signal Line Connections

Route the outgoing signal line circuits into the 165802 cabinet by means of the rectangular opening on the top left side. Connect the signal lines to terminal strips immediately above and below the 1 5 LINES 10 20 designation. Note that positive battery is obtained from the

lower terminal strip marked + while negative battery is grounded and obtained from the upper terminal strip marked GND. Connect the No. 1 signal line to the No. 1 terminals, the No. 2 signal line to the No. 2 terminals, etc.

- f. Re-connect the power input cord from the 165801 cabinet to its 115 volt AC power source and place the toggle switch on the front of its power distribution panel in the ON position. Adjust each signal line current in accordance with Section III, 1.i. of this specification.

2. SERVICING INSTRUCTIONS

a. General

Refer to all applicable specifications for any servicing instructions. The RY30 and 280BA relays are referred to in this specification and all the other relays are covered by Bell Telephone Systems Practices.

b. Line Current Adjustment

It may become necessary in the future to readjust the line current or even to "pad" the lines with additional voltage sources as required. The adjustment procedure is outlined in this specification, Section III, 1.i.

c. Replacement of Fuses

(1) REC55 and REC56 Power Supply Fuses

A 10 ampere fuse is used in each of the power inputs to these two power supplies. If a fuse blows, the associated power supply will not be energized. This fact is indicated by a rectifier fail lamp that lights and a buzzer sounding. Replace the blown fuse with the spare one provided on the unit. (Refer to Section II, 2.a.(13) of this specification for a complete description of the fuse alarm system.)

(2) Power Distribution Fuse Panel

There are 78 fuses and holders on this panel with 72 of these fuses used. Three of the balance are marked SPARES and the last three are not used (and so may be considered as spares). The three labeled fuses not in any circuit are the 40 volt CONTROL CIRCUIT and CROSS BAR SWITCH fuses and the 120 volt CROSS BAR SWITCH fuse. All the fuses on this panel are colored, the red ones being 1/2 ampere and the blue being 3 amperes. If any fuse fails the associated lamp will light, the buzzer will sound and the fuse itself will indicate it has failed. (Refer to Section II, 2.a.(13) of this specification for a complete description of the fuse alarm system).

d. Circuit Patching

In the event a line circuit panel malfunctions or requires maintenance, the signal line circuit which it controls may be patched directly into another signal line circuit until the trouble is cleared. The signal lines thus patched are connected in series. The circuit (CJ) and line (LJ) jacks necessary for circuit patching are located on the terminal board panel accessible from the rear of the 165802 cabinet. One patching cord is furnished with each line circuit panel.

- (1) Patching is accomplished by first placing the NORMAL-DISABLE key associated with the troubled line circuit in the DISABLED position. A patching cord is then inserted in the circuit jack (CJ) of the corresponding signal line which divorces the line from the switching package thus creating an open line condition. The other end of the patching cord is then placed into the line jack (LJ) of the desired signal line which is functioning normally. Re-adjust the line current of the circuit associated with the line jack (LJ).
- (2) When the trouble has been cleared, first remove the patching cord from the line jack (LJ) and then from the circuit jack (CJ). Return the NORMAL-DISABLE switch to the NORMAL position.

e. Open Line Condition

In the event a particular signal line circuit "opens" externally to the switching package, the associated OPEN LINE lamp lights on the open line disable panel. If this open line condition persists an abnormally long length of time, indicating a non-deliberate line break, the NORMAL-DISABLE key associated with the line circuit should be placed in the DISABLED position. This action removes the line circuit from TASP so that it will not tie-up the switching package. Also, a "BZ" answer-back will be transmitted to any circuit calling it. When the trouble has been cleared, return the key to the NORMAL position.

f. Replacement of RY30 (Western Electric 255-A) Relays

- (1) There is one RY30 relay (LS) used in the answer-back control panel of the 165801 cabinet and four RY30 relays (two LA and two LB) used in each line circuit panel of the 165802 cabinet. Efficient operation of this relay depends upon a periodical routine of inspection, cleaning, and adjustment (Refer to Section III, 2.a.).
- (2) Replacement of LS relay.
 - (a) The LS relay is accessible from the front of the 165801 cabinet by removing its lower front panel.

- (b) There is a toggle switch associated with the 2 AUX connector at the top of the terminal board panel in the 165802 cabinet. It is normally in the OFF position. Place the switch in the ON position and wait until all SELECT lamps on the open line disable panel are extinguished. Then replace the LS relay with a properly adjusted one.
 - (c) Return the toggle switch to the OFF position and replace the lower front panel on the cabinet.
- (3) Replacement of LA and LB relays in the topmost line circuit panel located behind the open line panel.
- (a) These relays are accessible from the front of the 165802 cabinet by removing both its lower and top front panels.
 - (b) Make certain that the LC1, LC2 and LC3 connectors are securely fastened.
 - (c) Remove the stile strip from the cabinet on each side of the open line disable panel. Notice that these two strips are not interchangeable.
 - (d) Remove the four mounting screws which fasten the open line disable panel to the cabinet.
 - (e) Wait until the particular line circuit is in an idle condition as indicated by its extinguished BUSY lamps and then place the associated NORMAL-DISABLE key in the DISABLE position.
 - (f) Pivot the open line disable panel outward from the bottom and replace the LA and LB relays with properly adjusted ones. Return the NORMAL-DISABLE switch to the NORMAL position.
 - (g) Replace the four mounting screws for the open line disable panel but do not fasten them at this time.
 - (h) Replace the lower front panel on the cabinet, raising the open line disable panel if necessary. Position the open line disable panel so that a minimum clearance of approximately $1/32$ " exists between it and the lower front panel. Secure the open line disable panel in this position.
 - (i) Replace the stile strips on the cabinet in the same manner in which they were removed making certain that they also clear the lower front panel.
 - (j) Replace the top front panel on the cabinet.

- (4) Replacement of LA and LB relays not located in the topmost line circuit panel.
- (a) These LA and LB relays are accessible from the front of the 165802 cabinet by removing only its lower front panel.
 - (b) Wait until the particular line circuit is in an idle condition as indicated by its extinguished BUSY lamp and then place the associated NORMAL-DISABLE key in the DISABLE position.
 - (c) Replace the LA and LB relays with properly adjusted ones.
 - (d) Return the NORMAL-DISABLE key to the NORMAL position and replace the lower front panel on the cabinet.

* Indicates Change
**Indicates Addition

RELAY CONTACT LOCATION ON WD 4451.
ANSWER-BACK CONTROL PANEL RELAYS.

DESIG.	BZ	BZBG1	BZBG2
CODE	AFB4	A52	AFB4
	CONT. ARR.	CONT. ARR.	CONT. ARR.
12	EM	LOC.	LOC.
11			
10	M		
9	B		M6
8	E	J7	K6
7	EM		
6	B		
5	EM	H5	G7
4	M	G7	
3			
2	M	J6	H15
1	M	K7	
COLL		H6	H16

LS

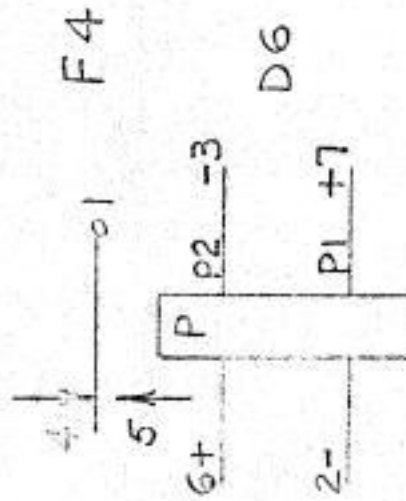

RELAY CONTACT LOCATION ON WD 4451.
COMMON CONTROL PANEL RELAYS.

DESIG. CODE	EC1 AJ12		EC2 AJ12		BG1 AG17		BG2 AG2		BG3 AG17		BG4 AG17		ST AF34	
	CONT. APP.	LOC.	CONT. APP.	LOC.	CONT. APP.	LOC.	CONT. APP.	LOC.	CONT. APP.	LOC.	CONT. APP.	LOC.	CONT. APP.	LOC.
12	E BM	B39	E BM	A39	E MB	E23	E MB	E23	E MB	E MB	E24	E MB	E MB	E24
11	E BM		E BM		M		M		M		M	M		
10	E BM		E BM		E BM		M		E BM		P28	E BM		M
9	E BM		E BM		E BM		B		E BM		N19	E BM		B
8	E BM		E BM		E BM		M		E BM		N19	E BM		E BM
7	E BM		E BM		B		B		B		D19	B		B
6	E BM		E BM		E MB	E22	M		E MB		D19	E MB		B
5	E BM		E BM		E BM		B		B		D20	E BM		B
4	E BM		E BM		E BM		M		E BM		D20	E BM		B
3	E BM		E BM		E BM		M		E BM		D20	E BM		M
2	E BM		E BM		E BM		M		E BM		G29	E BM		M
1	E BM		E BM		E BM		M		E BM		G29	E BM		M
coil														

TUBE, ELECTRON
DESIG. LOC. CODE
T D22 376C

RELAY CONTACT LOCATION ON WD 4451.
COMMON CONTROL PANEL RELAYS.

DESIG	ABC		UCR	
CODE	AJ202			
	CONT ARR	LOC	CONT ARR	LOC
24	M		M	
23	M		M	
22	M		M	
21	M		M	N20
20	M	G22	M	G22
19	M		M	
18	M		M	
17	M		M	
16	M		M	
15	M		M	
14	M		M	
13	M		M	
12	M		M	
11	M		M	
10	M		M	
9	M		M	
8	M		M	
7	M		M	
6	M		M	
5	M		M	
4	M		M	
3	M		M	Y
2	M	Y	M	G22
1	M	G22	M	
COIL		H22		D18

RELAY CONTACT LOCATION ON WD 4451. LINE CIRCUIT PANEL RELAYS

DESIG	BR1	BR2	BR3	SC	S	SR	3G	X								
CODE	AG 2						AJ35	AF 84				AG2		AF129		
	CONT ARR	LOC	CONT ARR	LOC	CONT ARR	LOC	CONT ARR	LOC	CONT ARR	LOC	CONT ARR	LOC	CONT ARR	LOC	CONT ARR	LOC
12									EM	D25	EM	G25			M	Q25
11															B	F25
10	M		M	M27	M	G25			M	C27	M	F26	M		BM	D27
9	B	L25	B	G25	B				B	M26	B		B		B	H27
8	M	G25	M		M	L25			EBM	F26	EBM	H25	M		BM	J27
7	B	D27	B	G27	B		B	L26	B	B1025	B		B		B	L26
6	M	G26	M	L26	M	L26	M	L25	B	S3036	B	K26	M	H25	BM	F27
5	B	L27	B	M27	B	D27			BM	E25	BM	F27	B	F27	B	M26
4	M	M27	M	M27	M	M27			M	K25	M	N25	M	K27	BM	C27
3															B	M27
2	M	M26	M	M26	M	M25			M	G26	M		M	N25	M	G26
1									M	G27	M	K27			B	N25
COIL		N27		M26		M27		L26		K26		K27		K26		H26

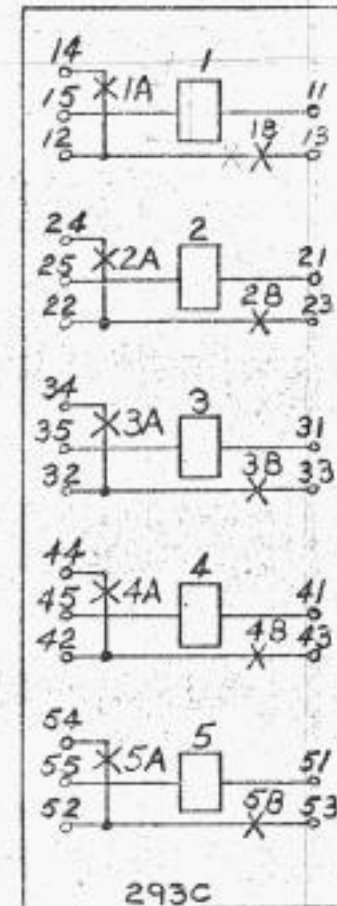

DESIG	LBC	293C			OLC	
CODE		1	2	3	4	5
POS						
CONT	A	X			X	
	B	P25			E27	
COIL	Q26				P26	

