

INSTRUCTIONS FOR INSTALLING THE 164502 MODIFICATION KIT TO PROVIDE MODEL 28 SEND-RECEIVE KEYBOARD (LK) AND AUTOMATIC SEND-RECEIVE KEYBOARD BASE (LAK) WITH AN END-OF-MESSAGE CHARACTER GENERATOR; AND INSTRUCTIONS FOR INSTALLING THE 173122 MODIFICATION KIT TO ELIMINATE INTERFERENCE BETWEEN COMPONENTS OF THE 164502 MODIFICATION KIT (EARLY DESIGN) AND 154240 AND 162308 CODE BAR RESET BAILS.

The chart below pertains to Bell System only:

Teletype Unit	Teletype Code	Bell Code	Bell System Reference
Send-Receive Keyboard with Perforator	LAK & Reperforator	28A, 28B 28D, 28E 28F, 28G 28G-1	Perforator Transmitter Base
Send-Receive Keyboard	LK	28D, 28E	Send-Receive Base

1. GENERAL

a. The 164502 Modification Kit provides a Model 28 Send-Receive Keyboard (LK) and Automatic Send-Receive Keyboard Base (LAK) with an end-of-message character generator.

(1) The 164502 Modification Kit permits the automatic inserting of the end-of-message sequence in the perforated tape or on the typed page of the page printer. It will perform the same functions as the keyboard when the "K-KT-T" keyboard switch is in each of the following positions:

"K" Position - The character generator will transmit the end-of-message sequence to the signal line.

"KT" Position - The character generator will transmit the end-of-message sequence to the signal line and perforate either typed or untyped tape.

"T" Position - The character generator will be mechanically blinded from the signal line but it will perforate typed or untyped tape.

(2) The 164502 Modification Kit has a total capacity of 21 characters.

The first character transmitted must always be a "LETTERS" combination; the remaining 20 may be any characters desired. The arbitrary characters are determined by detachable code blades set in a code drum. The entire code drum may be readily replaced

with the aid of a spring hook. Since projections on the code blades are used to rotate the drum, all of its 21 slots must be occupied by a blade.

NOTE

The first character transmitted is determined by a special stop code blade (LETTERS combination). Although only one such blade is included with this kit, the code drum could be equipped with any number of stop code blades to reduce the number of characters in the end-of-message sequence. To maintain a uniform message, the number of stop code blades used must be three or seven. Three stop blades equally spaced about the code drum would result in a message of six arbitrary characters preceded by the LETTERS combination. Seven stop code blades equally spaced about the code drum would result in a message of two arbitrary characters preceded by the LETTERS combination.

(3) The 164502 Modification Kit end-of-message sequence is initiated from the keyboard by momentarily depressing the end-of-message (EOM) key. This action closes a pair of electrical contacts and mechanically locks the keyboard by means of a locking code bar. The movement of the locking bar closes another pair of electrical contacts and completes an electrical circuit to the trip magnet of the character generator mechanism. Operation of the trip magnet actuates the mechanism and all 21 characters are transmitted by the keyboard signal generator and/or perforated in tape as indicated in (1) above. Upon the completion of the 21st character, the mechanism is automatically reset by means of the stop code blade. Before keyboard transmission can be resumed the keyboard must be manually unlocked by depressing the SEND key lever.

(4) THEORY OF OPERATION 164502 Modification Kit (Refer to Figure 1, 2, 5, and 7)

(a) The end-of-message sequence is initiated from the keyboard by momentarily depressing the end-of-message (EOM) key lever assembly located in the 21st slot of the code lever guide. This action results in the closure of a normally open contact assembly located beneath the key lever and the locking of the keyboard by means of a lever extension of the existing keyboard locking mechanism. The key lever becomes locked when the lock bar moves to the right. Normally open contacts (formerly used to electrically shunt the keyboard signal generator) are closed which completes an electrical circuit to the trip magnet of the character generator mechanism.

(b) The application of voltage energizes the trip magnet and results in the counter-clockwise rotation of the armature and associated stop lever latch thereby unblocking and releasing the stop lever. Under the bias of a spring attached to the code bar bail latch operating lever, which rests on the left extension of the stop lever, the stop rotates counter-clockwise until it comes to rest against the mechanism base plate. Before coming to rest the stop lever moves the blocking lever counter-clockwise, thereby blocking the drive plate and releasing it to its spring action. The drive plate rotates counter-clockwise to a stop where the attached drive link is in a position to accept the feeding motion from the keyboard code bar bail. As the stop lever continues its counter-clockwise rotation, the code bar bail latch rotates clockwise, striking the code bar bail latch. The latch rotates clockwise and releases the code bar bail. The code bar bail releases the keyboard code bars and the clutch trip bar which move to the right under spring action. The clutch trip

bar thereby trips the signal generator clutch and/or perforator clutch, depending upon the position of the K-KT-T control switch, and initiates an operating cycle.

(c) While the code combination transmitted and/or perforated during the first cycle must be a "LETTERS" combination, the code combinations of the succeeding 20 cycles may be any arbitrary character determined by the detachable code blades fastened to the code drum. The code combination on each blade is read by five sensing levers which transfer the code selections to a vertical projection on each of the five code bars. Each code combination is thus transmitted and/or perforated in the normal manner by the keyboard signal generator and/or perforator mechanism. A spacing condition occurs whenever a code bar is prevented from moving to the right by its associated sensing lever; unrestricted movement of a code bar results in a marking condition. Since the sensing levers must be held away from the code bars in order to prevent their interference during normal keyboard operation, a stop code blade having a "LETTERS" combination must be employed. This necessity results in a "LETTERS" combination for the first character.

(d) Once during each rotation (360°) of the signal generator cam assembly, or half rotation (180°) of the perforator cam assembly, depending upon the position of the K-KT-T control switch, the code bar bail is pulled to the left by a cam eccentric causing it to rotate clockwise. The bail thereby resets the keyboard code bars and, with the character generator drive link now in its released position, rotates the drive plate clockwise. This action causes the stepping pawl to step the code drum one position clockwise.

(e) With the stop lever in its released position, the code bar bail latch operating lever also maintains the code bar bail latch in a released position. The signal generator and/or perforator mechanism will cycle continuously until it rotates the code drum one full revolution or 21 characters. The first code blade, which is the stop code blade having a "LETTERS" combination, has an additional projection such that when it is being rotated into the sensing position it contacts the stop lever rotating it clockwise. The left extension of the stop lever rotates the code bar bail latch operating lever counter-clockwise which in turn releases the code bar bail latch to the action of its attached spring. Continued rotation of the stop lever brings it in a position where, if released to the action of the spring attached to the code bar bail latch operating lever, it will reverse rotation and become latched on the stop lever latch attached to the trip magnet armature. Such a position is reached when the stop code blade passes its area of contact with the stop lever which is just prior to the complete movement of the stop code blade into the sensing position.

(f) When the code bar bail latch is released to its spring action, it rotates counter-clockwise in contact with the code bar bail latch roller until it latches the code bar bail. At this point the blocking lever is also released to its spring action and it rotates counter-clockwise until it rests against a projection on the stop lever. In this position the blocking lever holds the drive plate in its extreme clockwise position and the attached drive link is once more unable to follow the feeding motion from the code bar bail. Further operation of the signal generator and/or perforator mechanism and character generator is thus prevented. At this point the keyboard is restored to its normal operating condition except that it must be manually unlocked by depressing the "SEND" key lever before operation can be resumed.

(g) The message of the character generator may be changed by replacing the entire code drum of the mechanism. See Paragraphs 2.B. (1) through (9) for the necessary instructions.

b. The 173122 Modification Kit eliminates interference between components of the 164502 Modification Kit (Early Design) and the 154240 and 162308 Code Bar Reset Bails.

NOTE

The 164502 Modification Kit furnished at the present time does not interfere with the 154240 and 162308 Code Bar Reset Bails. The 164502 Modification Kit (Early Design) containing the 164139 Lever, 164141 Spring Post, and 164159 Link require the 173122 Modification Kit to eliminate interference with the 154240 and 162308 Code Bar Reset Bails.

c. The 164502 Modification Kit consists of:

<u>Qty</u>	<u>Part No.</u>	<u>Description</u>	<u>Qty.</u>	<u>Part No.</u>	<u>Description</u>
5	2191	Washer, Lock	4	156740	Screw, Hex.
1	3598	Nut, Hex.	1	162873	Switch, Assembly
5	7002	Washer, Flat	1	162874	Plate, Clamp
1	45815	Washer, Lock	2	162875	Bracket
1	93984	Washer, Lock	1	162876	Bar, Retainer
1	112626	Nut, Hex.	1	163106	Key Lever Assembly
2	121473	Stud	1	163979	Lever, Function
1	151632	Screw, Hex.	1	164129	Answer-Back Parts
1	151687	Screw, Fil.			Common
1	151880	Nut, Hex.	1	164496	Bail
1	154125	Spring	1	164497	Eccentric
2	155750	Sleeve, Insulating	1	164499	Bar, Locking
4	155753	Sleeve, Insulating	1	164500	Cable Assembly, Resistor Mounting

d. The 173122 Modification Kit consists of:

1	173028	Post, Spring	1	173095	Link
1	173029	Lever, w/Hub Latch Operating	1	173096	Stud, Eccentric

e. For part numbers referred to and for parts ordering information, see Teletype Model 28 Page Printer Parts Bulletin 1149B and Model 28 Automatic Send-Receive Set Parts Bulletin 1169B.

2. INSTALLATION

a. The 164502 Modification Kit

NOTE

Refer to Teletype Model 28 Page Printer Set Bulletin 217B and Teletype Model 28 Perforator

Transmitter Bulletin 250B for removal of major components and assemblies.

- (1) Remove the keyboard from the cabinet in accordance with standard practice.
- (2) Remove the signal generator from the keyboard in accordance with standard practice.
- (3) Remove the key lever guide plate from the keyboard in accordance with standard practice.
- (4) Remove and discard the 154197 Plastic Plug and 117608 Speed Nut from the keytop hole, sixth from the left in the top row.
- (5) Maneuver the 163979 Function Lever into the 21st slot of the 154070 Code Lever Guide until it is fully seated on the 154016 Code Bar Lever Shaft.
- (6) Install a 154125 Spring on the 163979 Function Lever and 154070 Code Lever Guide.
- (7) Replace the key lever guide plate on the keyboard in accordance with standard practice. Readjust the space bar bail pivot. Do not replace the keyboard hood until so instructed.
- (8) Remove the 111343 Lock Ball Retainer Clamp from its present position in the center of the 154175 Lock Ball Channel and install it in the position immediately to the right of center.
- (9) Install the 163106 Key Lever Assembly (EOM) in the keytop guide hole previously unplugged, snapping onto the 163979 Function Lever previously installed in this position. (Refer to Figure 2).
- (10) Remove the 151631 Screw, 2191 Lock Washer and 7002 Flat Washer which fasten the 154175 Lock Ball Channel to the 154210 Left Frame Mounting Bracket. Refasten the channel to the bracket using a 121473 Stud instead of the 151631 Screw (Refer to Figure 2).
- (11) Remove the 151631 Screw, 2191 Lock Washer and 7002 Flat Washer which fasten the 154175 Lock Ball Channel to the 154211 Right Frame Mounting Bracket. Refasten the channel to the bracket using a 121473 Stud instead of the 151631 Screw. (Refer to Figure 2).
- (12) Check and, if necessary, make the Lock Ball Channel Adjustment.
- (13) Place a 162875 Bracket on top of each 121473 Stud and assemble them only friction tight with two 156740 Screws, 2191 Lock Washers and 7002 Flat Washer. (Refer to Figure 2).
- (14) Install the 162876 Retainer Bar on top of the two 162875 Brackets and assemble it only friction tight with two 156740 Screws, 2191 Lock Washers and 7002 Flat Washer. (Refer to Figure 2).

- (15) Install the 162873 Switch Assembly on the 162876 Retainer Bar and assemble it only friction tight with the 162874 Clamp Plate, 151687 Screw, 93984 Lock Washer and 151880 Nut. Move the contact assembly along the retainer bar until it is beneath the 153979 Function Lever previously installed. (Refer to Figure 2).
- (16) Place the keyboard control switch in the "K" keyboard position
- (17) Remove the lock bar contact assembly and its 158299 Cover from the keyboard. Do not disconnect any wires at this time.
- (18) Remove the 151631 Screw and 2191 Lock Washer which fastens the front of the 154008 Code Bar Guide, 158226 Bracket and 158230 Bracket to the 154068 Right Side Code Lever Guide Bracket. Loosen the rear 151631 Mounting Screw so that it is friction tight.
- (19) Pivot the 158226 Bracket upward so that its attached 158228 Lever disengages the slot in the 158010 Lock Bar.
- (20) Remove the 151630 Screw and 2191 Lock Washer which fastens the front of the 154008 Code Bar Guide and 158063 Stop Bracket to the 154069 Left Side Code Lever Guide Bracket. Loosen the rear 151630 Mounting Screw so that it is friction tight.
- (21) Pivot the 158063 Bracket downward so that its stop clears only the 158010 Lock Bar.
- (22) Slide the 158010 Lock Bar to the right until it clears the right side 154008 Code Bar Guide. Disengage the lock bar from the 154023 Lock Bar latch and lift it upward and to the left so that it is removed from the code lever guide assembly. Discard the 158010 Lock Bar.
- (23) Replace the 158010 Lock Bar with the 164499 Lock Bar reversing the procedure outlined in Paragraphs (17) through (22) above. Re-adjust the code bar guide clearance.
- (24) Install the 164497 Eccentric on the 164496 Bail with a 45815 Lock Washer and 112626 Nut. (Refer to Figure 3).
- (25) Remove the 3598 Nut, 2191 Lock Washer and 7002 Washer which fasten the 121242 Clamp to the 154149 Line Break Switch Cable. Also remove the two 153841 Screws and 2191 Lock Washers which fasten the 154039 Line Break Switch Bracket to the keyboard.
- (26) Remove the two 119653 Retaining Rings from the left side of the 154092 Function Lever Shaft. Slide the shaft to the right until its left end is approximately in line with the roller on the 154239 Universal Extension mounted on the 154179 Universal Bail. Note the position of all function levers thus removed from the shaft so that they may be readily replaced.
- (27) Rest the keyboard on its back side so that it is supported by the motor. From the bottom of the keyboard maneuver the 164496 Bail with 164497 Eccentric into its proper position on the 154059 Function Bail Bracket. Hold the bail with its long extension upward

and its bearing holes at right angles to the 154092 Shaft. Insert the long extension of the bail upward through the base cutout in line with the previously installed 163979 Function Lever (EOM). Position the 164496 Bail Extension so that it engages the 163979 Function Lever in a similar manner as the 154099 Local Carriage Return Function Bail engages its associated function lever. Place the 164496 Bail in the function bail bracket slot immediately to the left of the 163979 Function Lever so that the 164497 Eccentric is atop the 154067 Keyboard Lock Function Lever. Slide the 154092 Shaft to the left into the bearing holes of the 164496 Bail and all original function levers previously disengaged. Secure the 154092 Shaft with the two 119653 Retaining Rings previously removed. (Refer to Figure 3).

(28) Replace the parts previously removed in Paragraph (25) above. Make the following keyboard lock adjustment at this time:

Keyboard Lock Bail Eccentric (Figure 3)

(29) Replace the 154127 Nut which fastens the 173096 Eccentric Stud to the 160408 Code Bar Bail with the 164137 Shoulder Nut. Assemble the shoulder nut with its groove toward the cut-out in the code bar bail. (Refer to Figure 4).

(30) Unhook the 154191 Code Bar Bail Latch Spring from the 154089 Spring Post. Remove the 154079 Stud with the 158268 Code Bar Bail Latch, 154191 Spring, 115122 Felt Washer and 119651 Retaining Ring from the 154102 Signal Generator Rear Plate. Remove the latch, spring, felt washer, and retaining ring from the stud. Discard the stud. Install the latch, its spring and felt washer on the 164138 Stud. Re-assemble the stud on the signal generator rear plate. Maneuver the 173029 Latch Operating Lever onto the 164138 Stud so that it extends through the cut-out in the code bar bail with its hub adjacent to the 158268 Latch and its right side projection overlapping the latch. Retain the 173029 Lever and 158268 Latch on the 164138 Stud with the original 119651 Retaining Ring. (Refer to Figure 4).

(31) Unhook the 154215 Code Bar Bail Spring from the 154089 Spring Post. Remove the 154089 Spring Post from the 154102 Signal Generator Rear Plate and replace it with the 173028 Spring Post. Replace the 154215 Code Bar Bail Spring and 154191 Code Bar Bail Latch Spring on the 173028 Spring Post. Place the 76422 Latch Operating Lever Spring on the 173029 Lever only. The 76422 Spring should be placed on the 173028 Post after the character generator mechanism has been installed on the keyboard. (Refer to Paragraph (62) and to Figure 4).

(32) Install the 150089 Screw and 151880 Lock Nut in the tapped hole located on the right side of the 173029 Latch Operating Lever. (Refer to Figure 4).

(33) Replace the signal generator on the keyboard in accordance with standard practice. Check and, if necessary, make the code bar and code lever clearance, the code bar bail, the code bar bail and non-repeat lever clearance, the universal bail latch lever, the universal bail extension, the ball wedgelock and ball track clearance, and the lock ball end play adjustment.

NOTE

The code bar bail adjustment must be checked for both the keyboard and perforator mechanisms of the LAK. The specified clearance requirement of some to 0.006 inch must also be refined to 0.004 inch to 0.006 inch.

(34) Remove and retain the 151739 Keytop Arrangement Identification Screw and its 2191 Lock Washer from the keyboard.

(35) Install the 164142 Mounting Bracket on the keyboard so that it is offset towards the top. Use the two mounting holes located on the left side of the 156574 Spring Post on the 154179 Universal Bail. Fasten the bracket with a 151722 Screw and 2191 Lock Washer and also the previously removed 151739 Identification Screw and 2191 Lock Washer. (Refer to Figure 5).

(36) The 164143 Mounting Plate for the character generator has all of its projection extending upwards with guide slots on its left side, and the trip magnet mounting projection on its right side. It is secured to the keyboard by means of the two elongated slots at the front and by one such slot at the rear. Mount a 164144 Side Plate at right angles to the top rear of the 164143 Plate by means of two mounting holes in the projections at the bottom of the side plate. Assemble the 164144 Side Plate only friction tight with two 151692 Screws and 2191 Lock Washers so that its bottom center projection is located in the cut-out of the 164143 Plate. (Refer to Figure 5).

(37) Place the 164146 Stop Lever on the 164145 Levers Pivot so that with the grooves in the pivot offset towards the rear, the lever rests on the rear 5/16" dia. and front 7/32" dia. portion of the pivot. The ear extension of the lever should then be at the front left side while the lever encircles the pivot on the right side. Place the 164148 Spacer on the 164145 Pivot in front of the 164146 Stop Lever. Insert the 164149 Blocking Lever in the small groove of the 164145 Pivot so that the 164148 Spacer is retained between the stop lever and blocking lever. The blocking lever should then rest against the left side of the upper ear extension on the stop lever. Hold the two levers together by installing the 42661 Spring in the spring eye of the 164149 Blocking Lever and the spring extension of the 164146 Stop Lever. (Refer to Figure 5).

(38) Place the rear projection of the 164145 Levers Pivot in the 1/8" hole near the bottom of the 164144 Side Plate mounted on the 164143 Plate. Place another 164144 Side Plate towards the front of the 164143 Plate so that it engages the front projection of the 164145 Levers Pivot and is positioned similarly to the rear 164144 Side Plate already installed. Assemble the front side plate only friction tight with two 151692 Screws and 2191 Lock Washers. (Refer to Figure 5).

(39) Install the 164150 Spring Bracket between the two 164144 Side Plates at the top right side so that the projections on the spring bracket engage the slots in the side plates. The contact point between the 164146 Stop Lever and 164149 Blocking Lever should be on the left side of the 164150 Spring Bracket. Assemble the 164150 Bracket only friction tight to the side plates with two 151152 Screws and 3640 Lock Washers. (Refer to Figure 5).

(40) Firmly press the two outer sides of two 164144 Side Plates towards each other so that each side plate bears against the front projection on the 164143 Mounting Plate, the 164145 Levers Pivot and the 164150 Spring Bracket; then securely fasten the six screws which mount the two side plates and the spring bracket. (Refer to Figure 5).

(41) Install five 151397 Sensing Lever Springs on the 164150 Spring Bracket in the five spring mounting holes which are towards the front side plate. Install the 151715 Detent Lever Spring on the 164150 Spring Bracket in the spring mounting hole adjacent to the rear side plate. (Refer to Figure 5).

(42) Install five 164154 Sensing Levers on the 164145 Levers pivot in the five grooves which are towards the front side plate. The left extension on each sensing lever should engage its corresponding guide slot on the left side of the 164143 Mounting Plate. Hook the five 151397 Sensing Lever Springs on the spring grooves of the five sensing levers. (Refer to Figure 5).

(43) Install the 164151 Detent Lever on the 164145 Levers Pivot in the groove near the rear side plate. The detent roller should be towards the top. Hook the 151715 Detent Lever Spring on the spring groove of the detent lever. (Refer to Figure 5).

(44) Install the 164155 Magnet Yoke on the right side extension of the 164143 Mounting Plate. The spring post should be towards the front with the mounting holes toward the rear. Fasten the yoke with two 153537 Screws, 2191 Lock Washers and 7002 Flat Washers. (Refer to Figure 5).

(45) Install a 119649 Retaining Ring on the 164157 Shaft in the groove located approximately 1/16" from one end. Install the 164156 Armature with its two projections extending upward between the two lower projections at the bottom of the 164155 Magnet Yoke. Retain the armature by means of the 164157 Shaft inserted from the rear through the two holes in both the yoke and armature. Install another 119649 Retaining Ring on the 164157 Shaft so that the rear projections on both the armature and yoke are retained between the two rings. (Refer to Figure 5).

(46) Install the 164158 Latch by means of its two mounting slots on the bottom of the 164156 Armature so that the latch extends in front of the yoke and to the left of the latching surface on the 164146 Stop Lever. Fasten the latch to the armature by means of two 151737 Screws, 110743 Lock Washers and 87398 Flat Washers. Install the 42661 Spring between the spring groove on the latch and the spring post on the yoke. (Refer to Figure 5).

(47) Install the 194M Magnet Coil on the 164155 Magnet Yoke between its upper projection and the 164156 Armature. The magnet coil terminals should extend upwards on the right side of the yoke when properly mounted. Fasten the coil with a 153799 Screw and 3640 Lock Washer. (Refer to Figure 5).

(48) Place the 164162 "O" Ring in the groove on the rim of the 164161 message drum which is furthest from the slot in the center portion of the drum. Install the 164163 Stop Blade in any slot position in the drum by first inserting the blade under the "O" ring and then rotating the blade toward the center of the drum until it is fully seated. (Refer to Figure 6).

(49) Code the drum in the following manner: (Refer to Figure 6).

1. Almost any end-of-message desired may be selected which does not contain more than 21 characters including spaces. However, the coding of the message drum always begins with a LETTERS (stop blade) and is normally followed by CARRIAGE RETURN and LINE FEED; the coding also normally ends with CARRIAGE RETURN and LINE FEED. This arrangement insures that the message will appear at the beginning of a line on the distant teleprinter and that over-printing of the message will not occur. Transmission of the LETTERS code combination at the beginning of the message also returns all teleprinters in the circuit to the unshift position. Since 5 of the 21 available characters are thus used to perform these functions, only 16 are available for the message itself. Of course, this procedure may be altered to suit a particular application of the end-of-message character generator feature.

2. Code the drum in a counter-clockwise direction beginning with the No. 2 164164 Code Blade adjacent to the 164163 Stop Blade. Each 164164 Code Blade is provided with removable tines for all levers of the transmission code (1, 2, 3, 4, 5). A "O" code level tine has been provided on each blade for future usage on six level keyboards and may be currently disregarded. A blade is coded by breaking off the unwanted tines at the scored line at the base of each tine. Figure 6, indicates that tines are to be removed for a particular character. To prevent distortion of a code blade, each blade should be held securely near the score mark of the tine to be removed. Although twenty code blades are sufficient to completely code the drum, twenty-five such blades have been provided to allow for possible errors in coding. Since each slot position in the drum must be occupied by a code blade, the unused characters under the twenty permitted for customer use shall be coded either for LETTERS or BLANKS or some such tolerable character.

3. Install each coded 164164 Blade in the proper slot position in the drum by first inserting the blade under the "O" ring and then rotating the blade toward the center of the drum until it is fully seated. After filling the code drum, encircle the code blades by placing another 164162 "O" Ring in the groove on the opposite rim of the 164161 Drum.

(50) Install the 164168 Stepping Pawl on the 164165 Drive Plate by means of the 164169 Eccentric Stud, 150411 Flat Washer, 3640 Lock Washer and 151880 Nut. Install the 42661 Spring between the pawl and drive plate by means of the spring eye in each part. (Refer to Figure 7).

(51) Apply a thin film of grease on the shaft of the 164165 Drive Plate. Install the message drum complete with coded blades and "O" rings on the shaft of the drive plate. Depress the stepping pawl extension to raise pawl sufficiently so that the drum bears against the hub on the drive plate and the pawl fully engages the projections of the code blades. Hold the assembled parts approximately as indicated in Figure 7 by means of the thumb and first two fingers of the left hand. Slide the drive plate shaft downward along the left sides of the curved slots in the 164144 Side Plates until the drum assembly is fully seated as indicated.

(52) To facilitate the adjustment of the character generator mechanism the following adjustments should be made before the mechanism is installed on the keyboard:

Magnet Yoke (Figure 10)
Stop Lever Latch (Figure 11)

(53) After making the magnet yoke and stop lever latch adjustments, remove the message drum by reversing the procedure used in its installation. The character generator mechanism may now be installed on the keyboard. Unfasten the screw which secures the cable clamp for the tape backspace button switch cable to the top of keyboard. With the parts assembled as indicated in Figure 5, maneuver the character generator mechanism so that the left side projection of the 164146 Stop Lever is under the 150089 Screw fastened to the 173029 Latch Operating Lever and the front portion of the 164143 Mounting Plate is resting on the keyboard base under the previously loosened cable clamp while the rear portion of the 164163 Plate is resting on the 164142 Mounting Bracket. Assemble the 164143 Mounting Plate only friction tight to the keyboard and bracket by means of two 153537 Screws, 2191 Lock Washers and 7002 Washers placed in the rear and right front mounting slots of the plate. Re-assemble the previously loosened cable clamp only friction tight to the keyboard by using its original mounting screw in the left front mounting slot of the 164143 Plate. (Refer to Figure 5).

(54) To facilitate the adjustment of the character generator mechanism, the following adjustment should be made when the mechanism is being installed on the keyboard after the signal generator has been replaced.

Mounting Plate (Figure 12)

(55) Install the 164500 Resistor Mounting Cable Assembly on the 154175 Lock Ball Channel by means of the mounting hole on the right side of the channel. Use a 151632 Screw, 7002 Flat Washer, 2191 Lock Washer and 3598 Nut to secure the assembly. (Refer to Figure 8).

(56) Connect the wires associated with the 164500 Resistor Mounting Cable Assembly as indicated on Figure 9. Temporarily remove the end-of-message keylever switch from the 162876 Retainer Bar to facilitate the soldering of the white-red (W-G) wires to it. Replace the switch and tie the white-red and white-green wires to the retainer bar. Disconnect the existing black wire from terminal No. 1 of the lock-bar switch; tape and tie back the wire. Disconnect the existing green wire from terminal No. 2 of the lock-bar switch, tape and tie back the wire. Connect the red (R) and white-red (W-R) wires of the 164500 Cable Assembly to the lock-bar switch as indicated. Route the white-blue (W-BL) and white-orange (W-O) wires to the character generator trip magnet; connect them as indicated. Tie the wires to the rear of the magnet yoke making certain that they do not interfere with any moving parts on the character generator of keyboard. Route the blue (BL) and red (R) wires to the motor terminal block, connect them as indicated. Use the 155750 and 155753 tubing as indicated.

(57) Check, and if necessary, make the keyboard lock bar switch adjustment. (Refer to Model 28 Adjustment Bulletin). Also, make the following end-of-message (EOM) keylever switch adjustments (Refer Para. 3 & Fig. 2):

Keylever Switch Position - Preliminary
Keylever Switch Horizontal Position
Keylever Switch Vertical Position

(58) Assemble the 173095 and 164160 Drive Links together as indicated in Figure 7. Use two 151152 Screws, 3640 Lock Washers and 125011 Flat Washers to assembly the parts only friction tight. Install the assembled drive links to the appropriate shoulder of the 173096 Code Bail Reset Eccentric Stud. Rest the 164160 Link along the rear side of the front 164144 Side Plate of the character generator. Install the 90573 Spring in the spring eye of the 164160 Link.

(59) Install the drive plate assembly without the message drum on the character generator mechanism as previously described. Hook the 90573 Spring on the 164169 Eccentric Stud making certain that the slot in the 164160 Drive Link engages the stud on the drive plate.

(60) Make the following character generator adjustment at this time:

Drive Link (Figure 13)

(61) Un-hook the 90573 Drive Link Spring from the 164169 Eccentric Stud. Disengage the slot in the 164160 Drive Link from the stud on the 164165 Drive Plate. Remove the drive plate assembly from the character generator mechanism. Install the message drum on the drive plate shaft and install the drum and drive plate assembly on the mechanism as previously described. Re-hook the 90573 Spring on the 164169 Stud. Make certain that the slot in the 164160 Drive Link engages the stud on the drive plate; if necessary, turn the drive plate with its attached stepping pawl held out of the engagement with the code blades so that the parts are properly aligned.

(62) Make certain that the 164146 Stop Lever is latched on the 164158 Latch. Install the 76422 Spring for the code bar bail latch operating lever on the 173028 Post.

(63) Refer to Figures 14 and 15 of this specification and make the following final character generator adjustments:

Stepping Pawl (Figure 14)
Latch Operating Lever Adjusting Screw (Figure 15)

(64) Make certain that the 164146 Stop Lever is latched on the 164158 Latch and also that the signal generator clutch is disengaged. Turn the message code drum clockwise until it is in its fully detented position the 164154 Sensing Levers are resting on the 164163 Stop Blade which is just below the pawl shaped surface on the upright projection of the 164146 Stop Lever. (Refer to Figure 7).

(65) Lubricate the character generator mechanism as indicated on the attached figures and then replace the keyboard hood and finally the keyboard in accordance with standard practice.

b. End-Of-Message Code Drum Change (See Paragraph 1. a. (4), (f) and Figure 7)

(1) Unhook the 90573 Drive Link Spring from the 164169 Eccentric Stud.

(2) Disengage the slot in the 164160 Drive Line from the stud on the 164165 Drive Plate.

(3) Grasp the code drum with the thumb and first two fingers of the left hand and while pushing the entire assembly to the right, lift the drum and its drive plate out of the mechanism. Slide the drum assembly from the shaft of the drive plate and replace it with the one desired.

(4) Depress the stepping pawl extension to raise the pawl sufficiently so that the new drum bears against the hub on the drive plate and the pawl fully engages the projections on the code blades.

(5) Hold the assembled parts as shown on Figure 7 and re-insert them in the character generator by reversing the disassembly instructions.

(6) Hook the 90573 Spring on the 164169 Eccentric Stud.

(7) Make certain that the slot in the 164160 Drive Link engages the stud on the drive plate; if necessary, turn the drive plate with its attached stepping pawl held out of engagement with the code blades so that the parts are properly aligned.

(8) If the code bar bail latch has been released during the above procedure, re-latch the 164146 Stop Lever on the 164158 Armature Latch and turn the motor hand-wheel or signal generator clutch is disengaged.

(9) Turn the code drum clockwise until in its fully detented position the sensing levers are resting on the 164163 Stop Blade which is just below the pawl shaped surface of the upright projection of the 164146 Stop Lever.

c. The 173122 Modification Kit - For Installation Instructions see the following Paragraphs and Figures:

- (1) 2.a. (29), Figure 4.
- (2) 2.a. (30), Figure 4.
- (3) 2.a. (31), Figure 4.
- (4) 2.a. (32), Figure 4.
- (5) 2.a. (53), Figure 5.
- (6) 2.a. (58), Figure 7.
- (7) 2.a. (62).

3. ADJUSTMENTS AND LUBRICATION

For standard adjustments and standard lubrication procedure refer to Teletype Model 28 Page Printer Set Bulletin 217B and Teletype Model 28 Perforator Transmitter Bulletin 250B.

a. For the 164502 Modification Kit make the adjustments and lubrication shown on the attached figures and following, referring to Figure 2.

(1) Keylever Switch Position - Preliminary

Requirement:

The centerline of the insulator on the center contact spring should be aligned with the centerline of the 163979 Function Lever.

To Adjust:

Loosen the 151830 Nut which fastens the switch assembly to the 162876 Retainer bar and position the switch. Tighten the nut.

(2) Keylever Switch Horizontal Position

Requirement:

The centerline of the insulator on the center contact spring should be aligned with the centerline of the lowermost portion of the 163979 Function Lever.

To Adjust:

Loosen the two 156740 Screws which fasten the 162876 Retainer Bar to the two 162875 Brackets and position the retainer bar. Tighten the screws.

(3) Keylever Switch Vertical Position

Requirement:

With a 0.035" feeler gage placed across the top of the 21st slot of the 154086 Wedge Lock Retainer and the 163106 Keylever Assembly (EOM) depressed until the gage is securely held between the 163979 Function Lever and the top of the wedge lock retainer there should be some to .006" clearance between the contact points on the center and lower contact springs.

To Adjust:

Loosen the two 156740 Screws which fasten the two 162875 Brackets on the two 121473 Studs and position the complete mounting assembly. Tighten the screws and recheck the requirement.

b. The 173122 Modification Kit

Make the Drive Link Adjustment shown on Figure 13.

SCHEMATIC WIRING DIAGRAM OF END-OF-MESSAGE CHARACTER GENERATOR

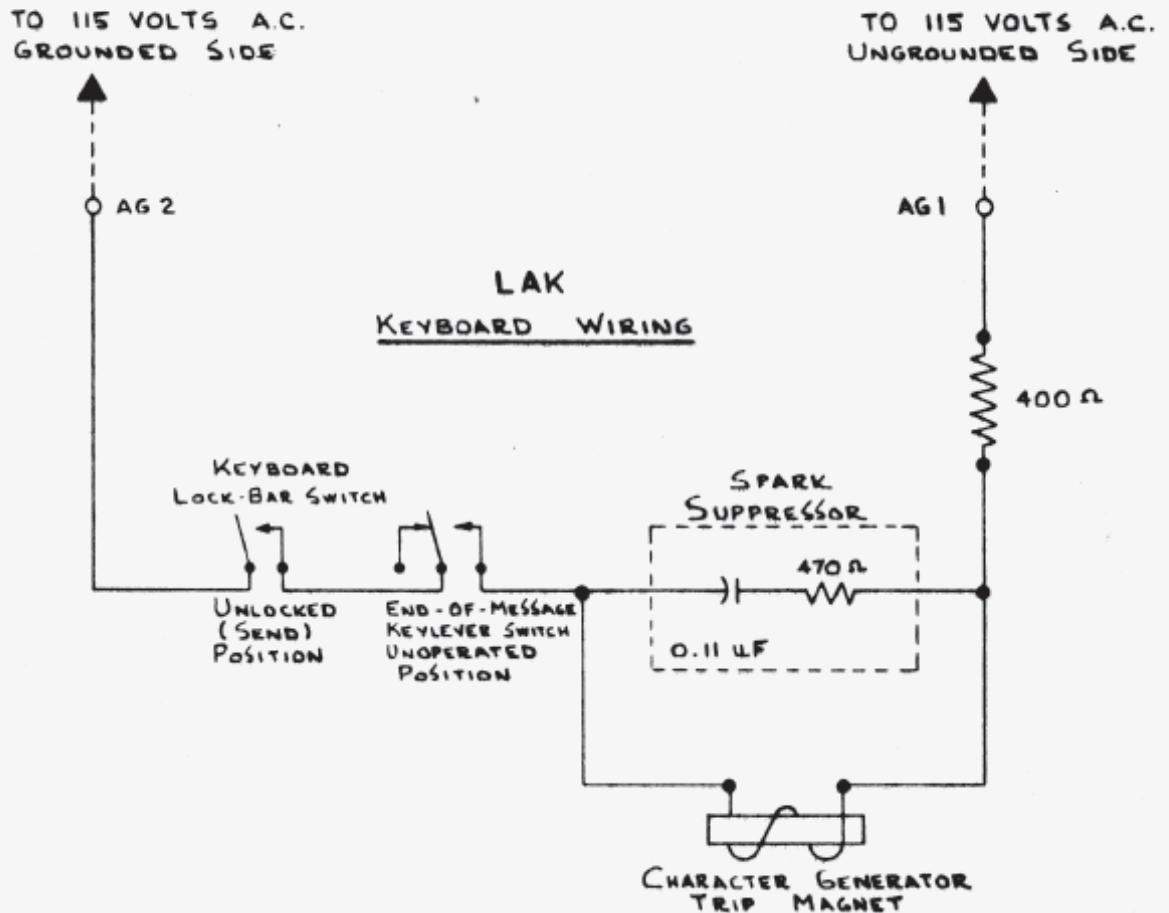

- AG MOTOR TERMINAL BLOCK ON KEYBOARD (LAK)
- EXISTING WIRES
- WIRES FURNISHED IN 164502 MOD. KIT

REFER TO WIRING DIAGRAM 3459 WD FOR COMPLETE SCHEMATIC DIAGRAM

FIGURE I

59545

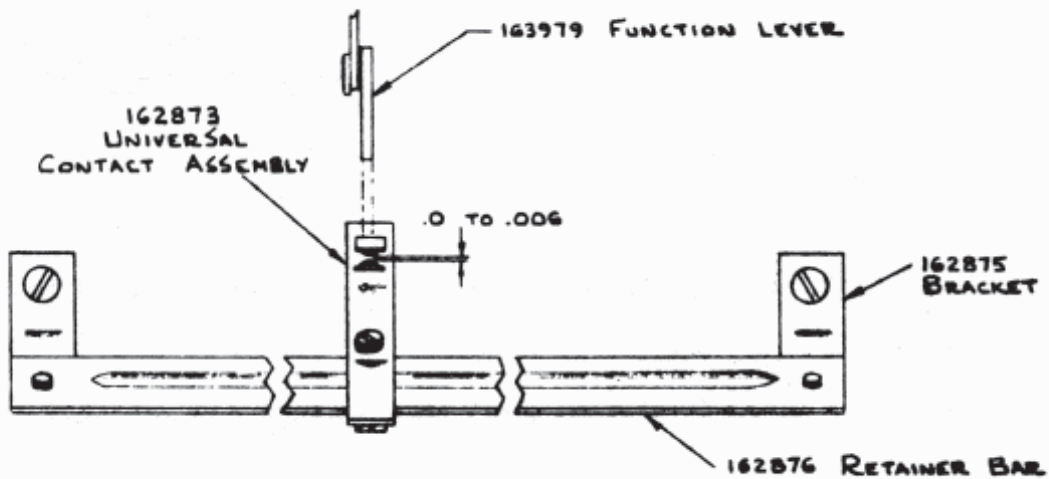
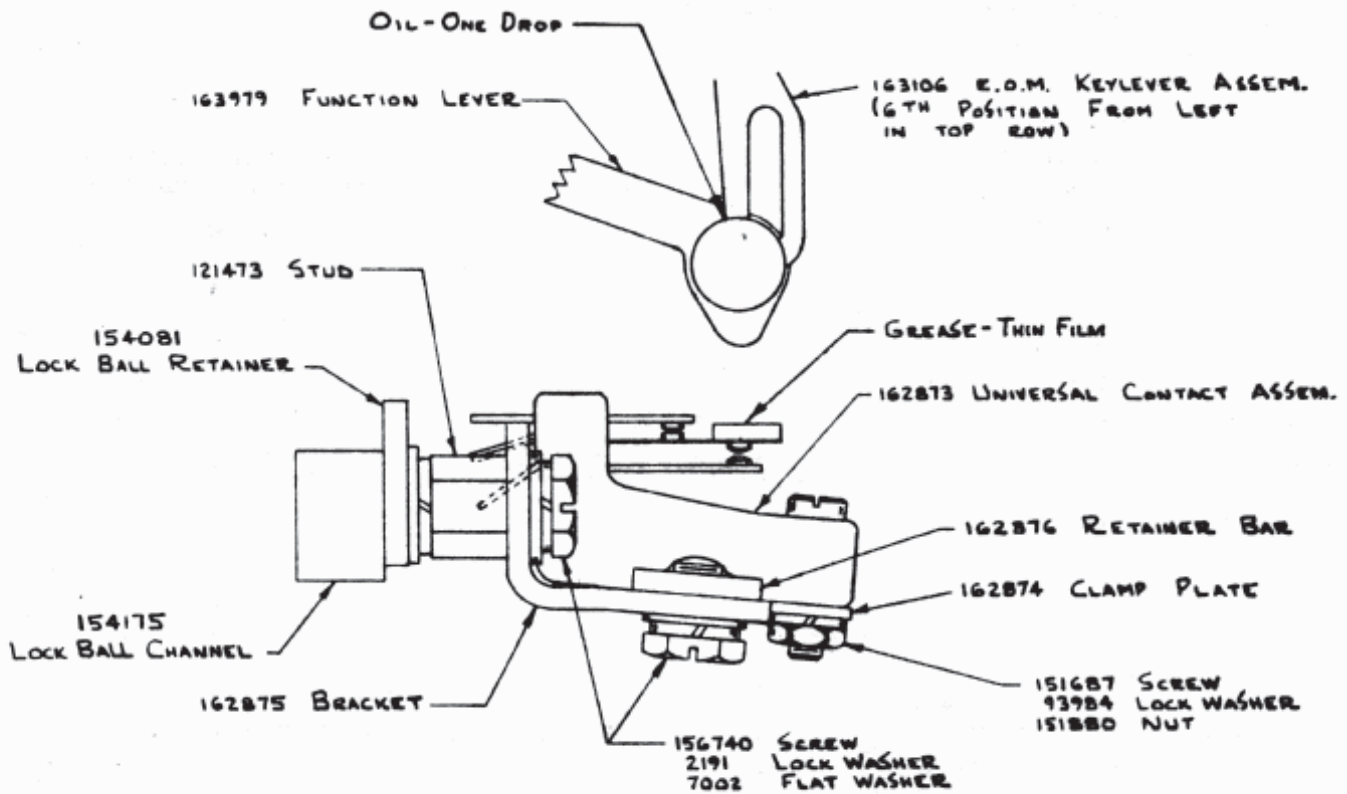
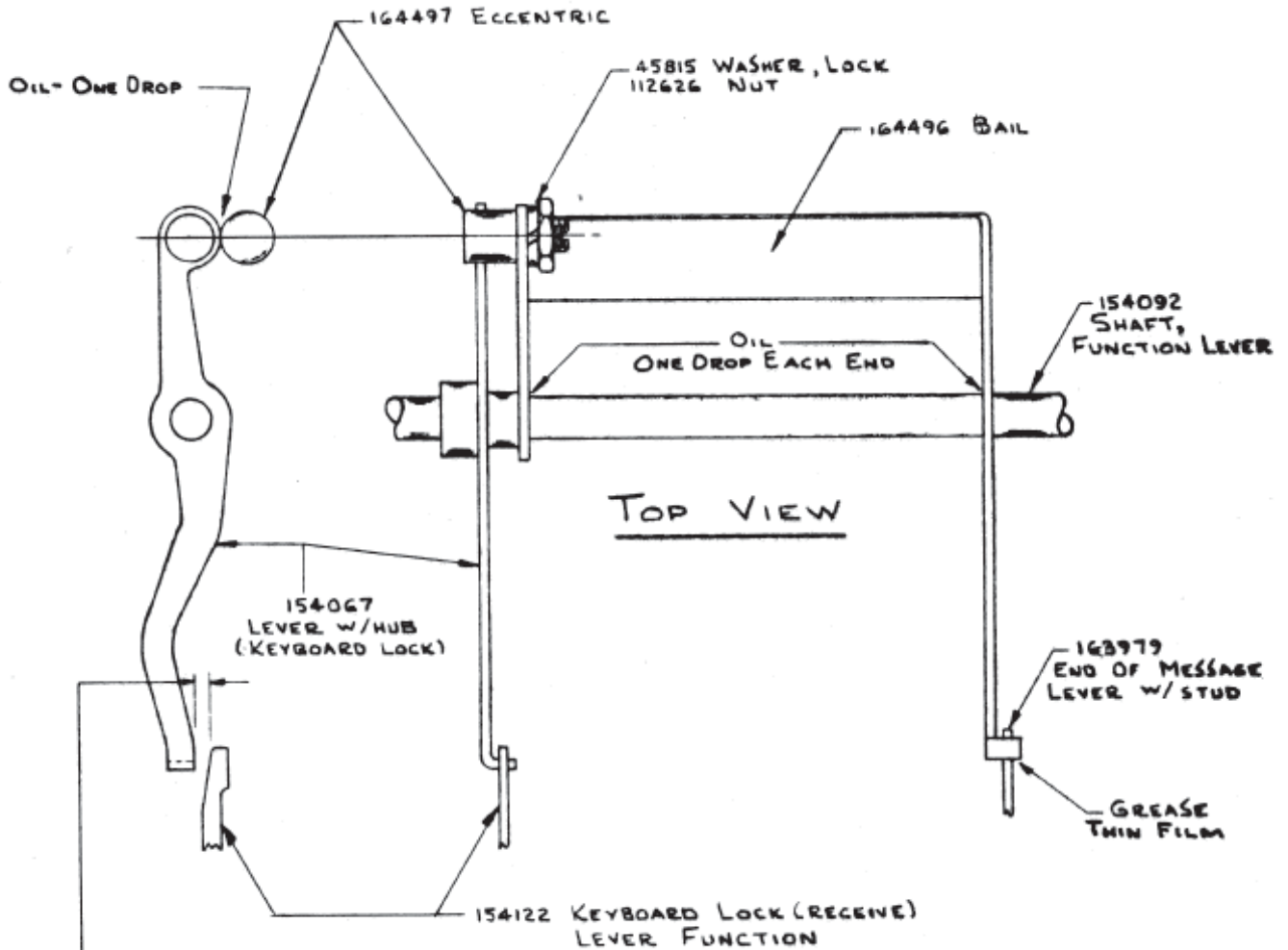

FIGURE 2

5954S



KEYBOARD LOCK BAIL ECCENTRIC ADJUSTMENT:

REQUIREMENT: WITH BOTH THE "REC" AND "EOM" KEYPADS LIGHTLY HELD FULLY DEPRESSED, THERE SHOULD BE SOME TO .006" CLEARANCE BETWEEN THE KEYBOARD LOCK LEVER W/HUB AND THE KEYBOARD LOCK FUNCTION LEVER.

To Adjust:

POSITION THE ECCENTRIC WITH ITS LOCK NUT LOOSENED SO THAT ITS HIGH POINT IS TOWARD THE FRONT OF THE KEYBOARD.

FIGURE 3

59545

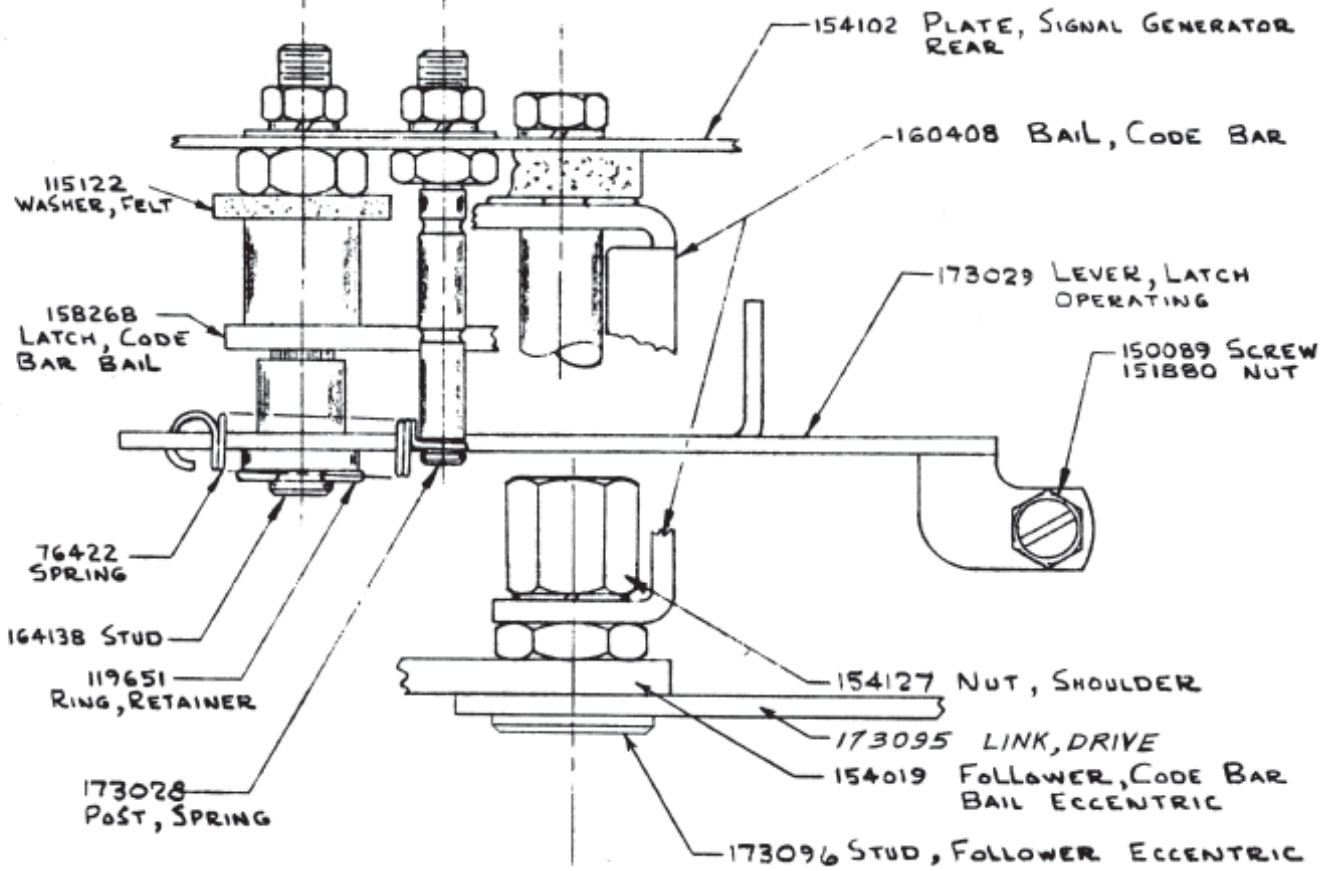

FIGURE 4

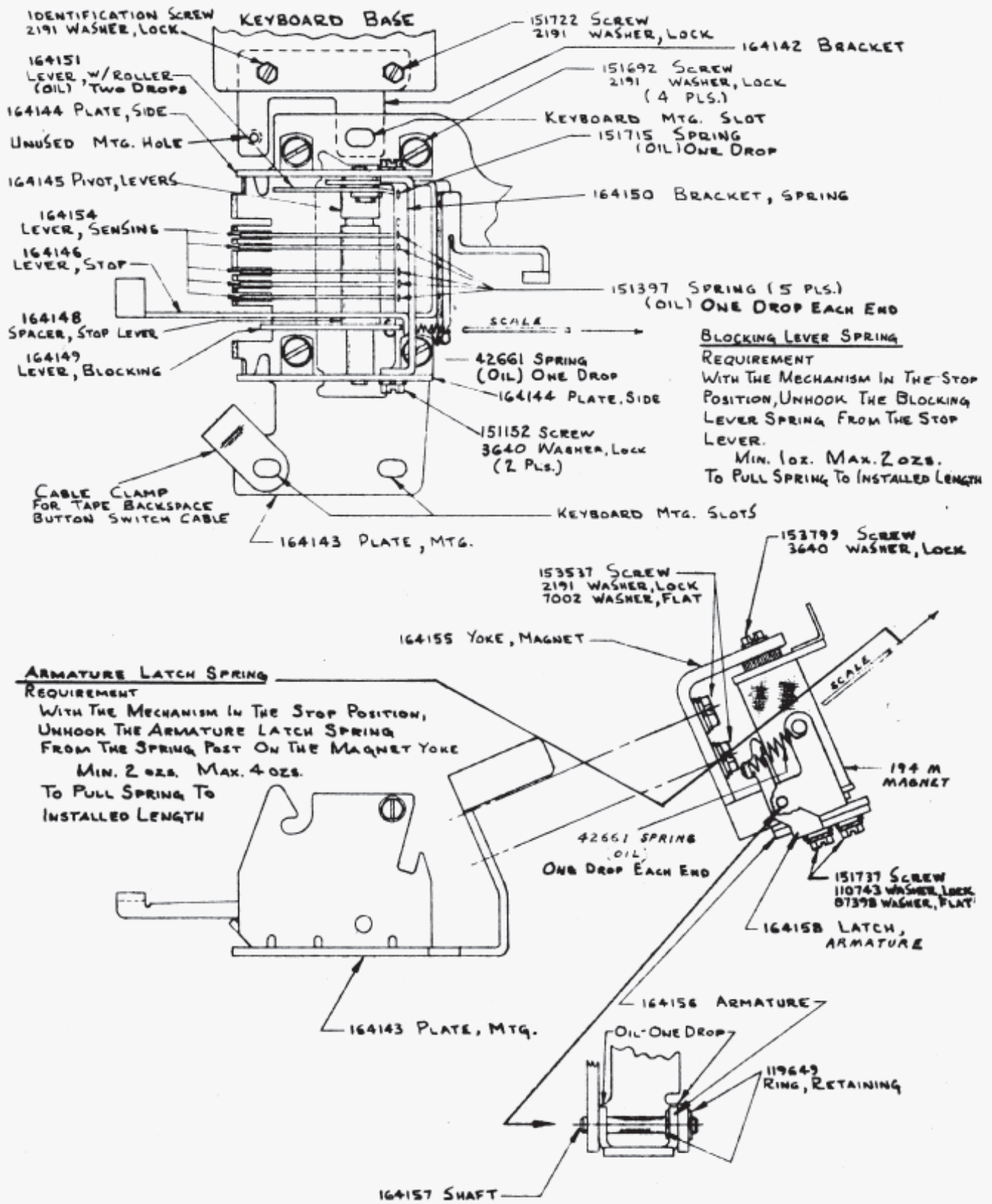
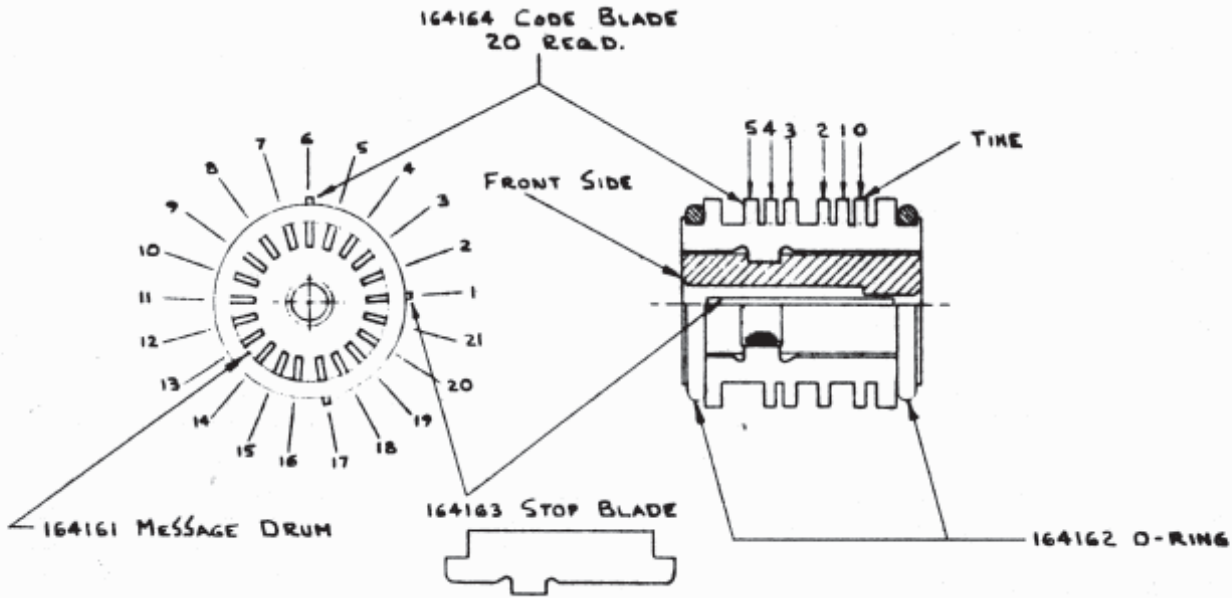

FIGURE 5



LETTERS	TYPICAL FIG. ARRGT.	CODE				
		1	2	3	4	5
A	-	■	■	■	■	■
B	?	■	■	■	■	■
C	:	■	■	■	■	■
D	\$	■	■	■	■	■
E	3	■	■	■	■	■
F	†	■	■	■	■	■
G	&	■	■	■	■	■
H	#	■	■	■	■	■
I	B	■	■	■	■	■
J	!	■	■	■	■	■
K	(■	■	■	■	■
L)	■	■	■	■	■
M	.	■	■	■	■	■
N	?	■	■	■	■	■
O	9	■	■	■	■	■
P	0	■	■	■	■	■
Q	1	■	■	■	■	■
R	4	■	■	■	■	■
S	BELL	■	■	■	■	■
T	5	■	■	■	■	■
U	7	■	■	■	■	■
V	;	■	■	■	■	■
W	2	■	■	■	■	■
X	/	■	■	■	■	■
Y	6	■	■	■	■	■
Z	"	■	■	■	■	■
CARRIAGE RETURN		■	■	■	■	■
LINE FEED		■	■	■	■	■
LETTERS SHIFT		■	■	■	■	■
FIGURES SHIFT		■	■	■	■	■
SPACE		■	■	■	■	■
BLANK		■	■	■	■	■

■ - LEAVE TINE
 □ - REMOVE TINE

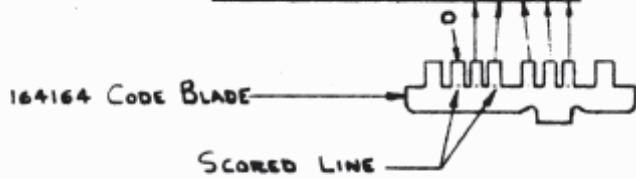

FIGURE 6

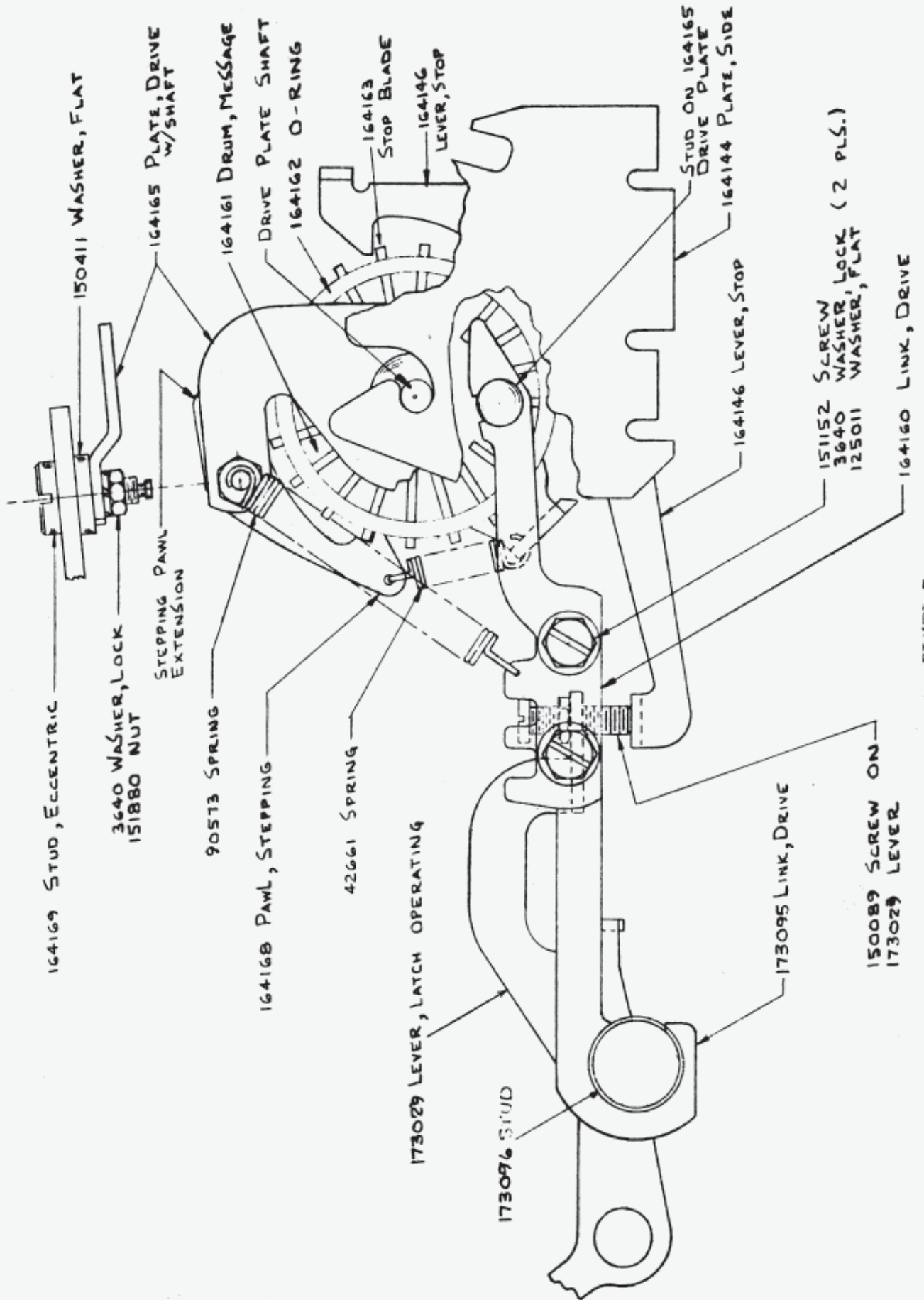

FIGURE 7

5954S

RIGHT SIDE OF CHANNEL

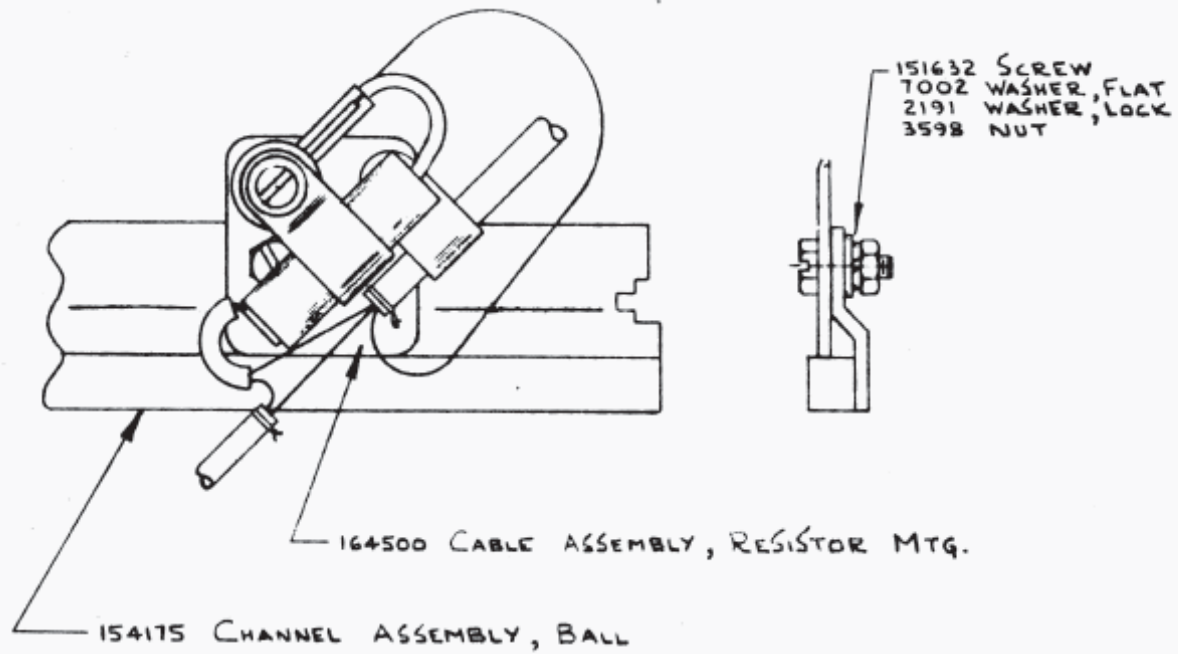
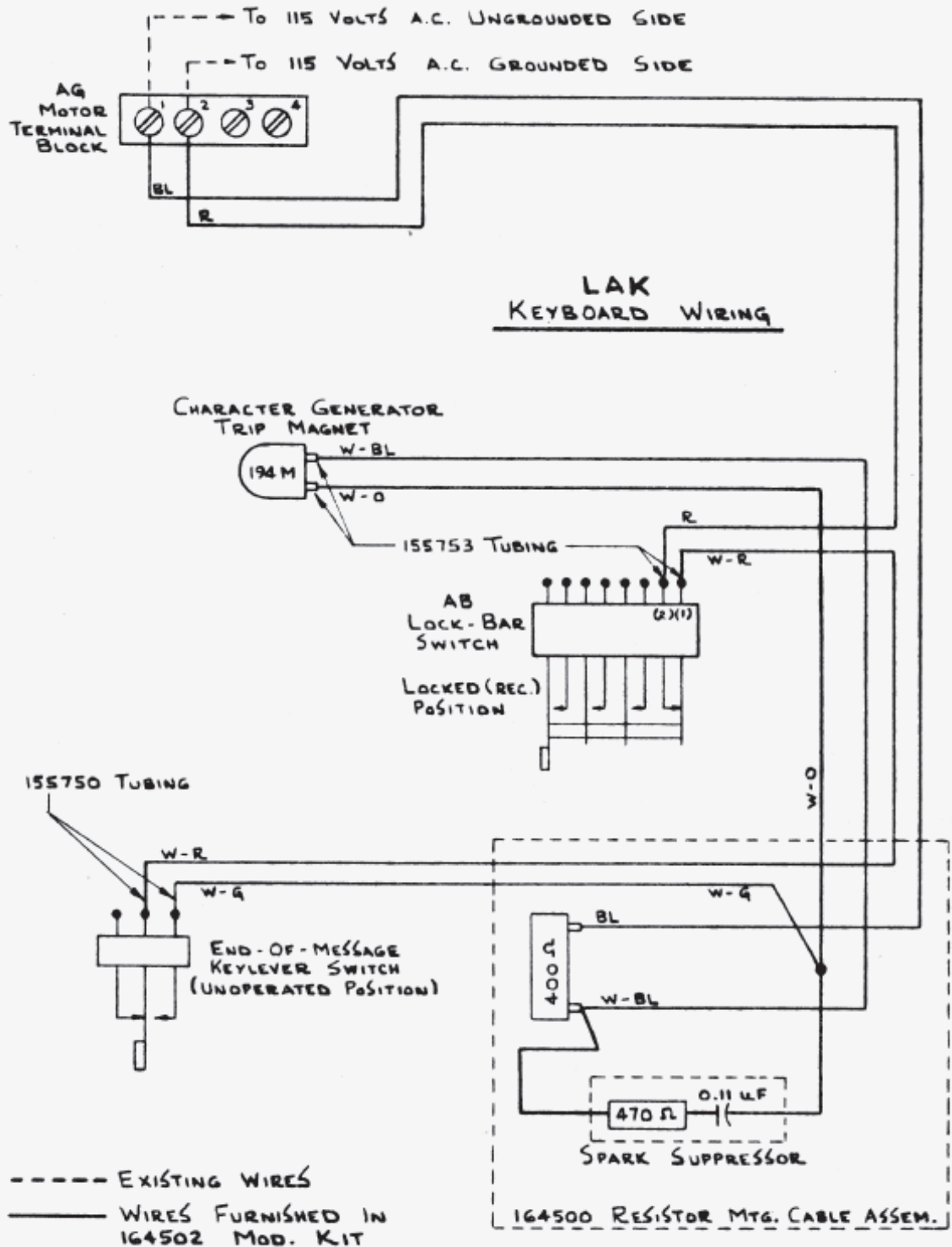

FIGURE 8

ACTUAL WIRING DIAGRAM OF END-OF-MESSAGE CHARACTER GENERATOR



REFER TO WIRING DIAGRAM 345BWD FOR COMPLETE ACTUAL DIAGRAM.

FIGURE 9

5954S

FIGURE 10

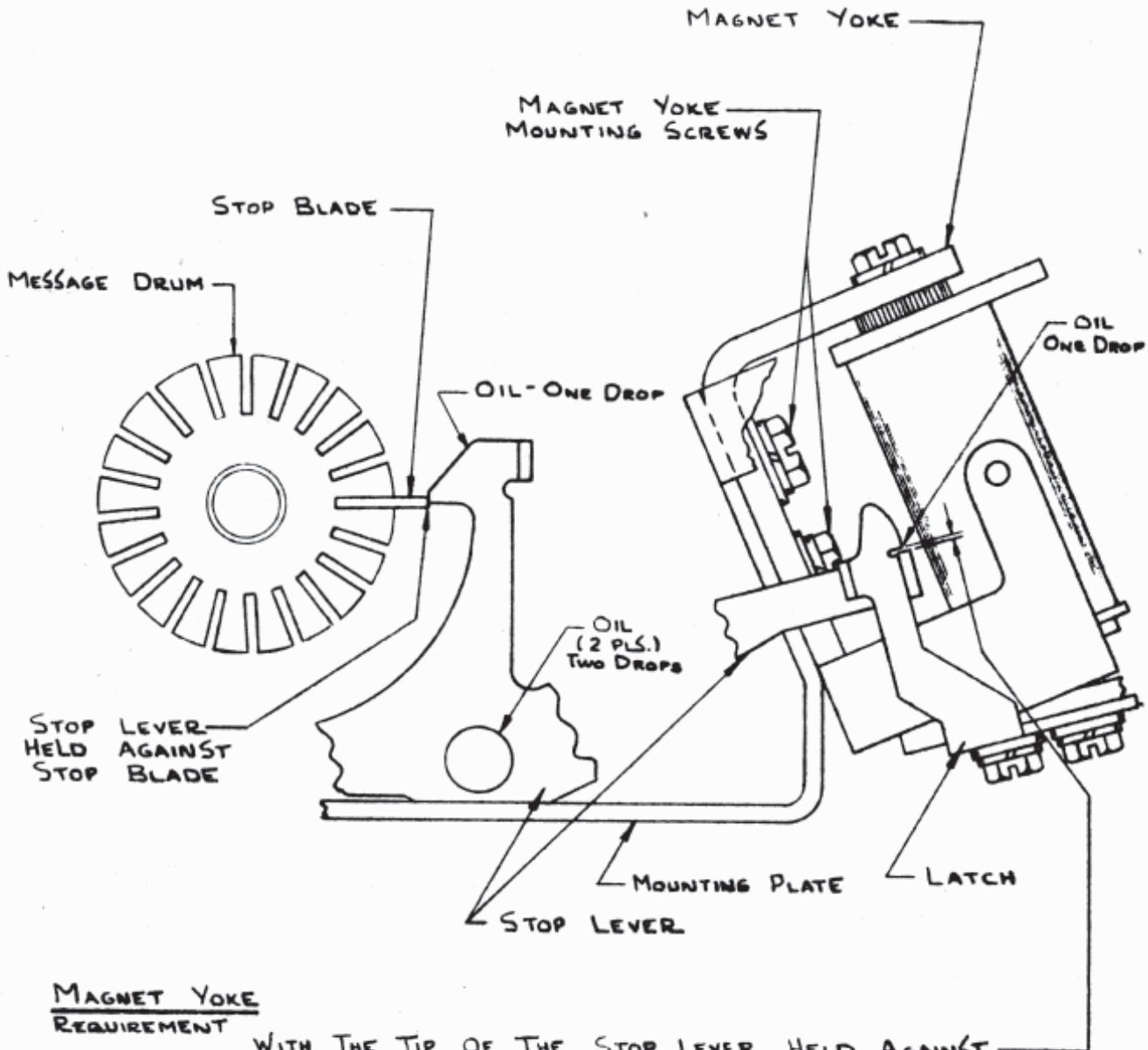

MAGNET YOKE
REQUIREMENT

WITH THE TIP OF THE STOP LEVER HELD AGAINST THE STOP BLADE THERE SHOULD BE FROM .005" TO .015" CLEARANCE BETWEEN THE LATCHING SURFACES ON THE STOP LEVER EXTENSION AND ITS LATCH.

To Adjust

ROTATE THE MESSAGE DRUM TO MEET THE REQUIREMENT AND THEN POSITION THE MAGNET YOKE BY MEANS OF ITS TWO MOUNTING SCREWS.

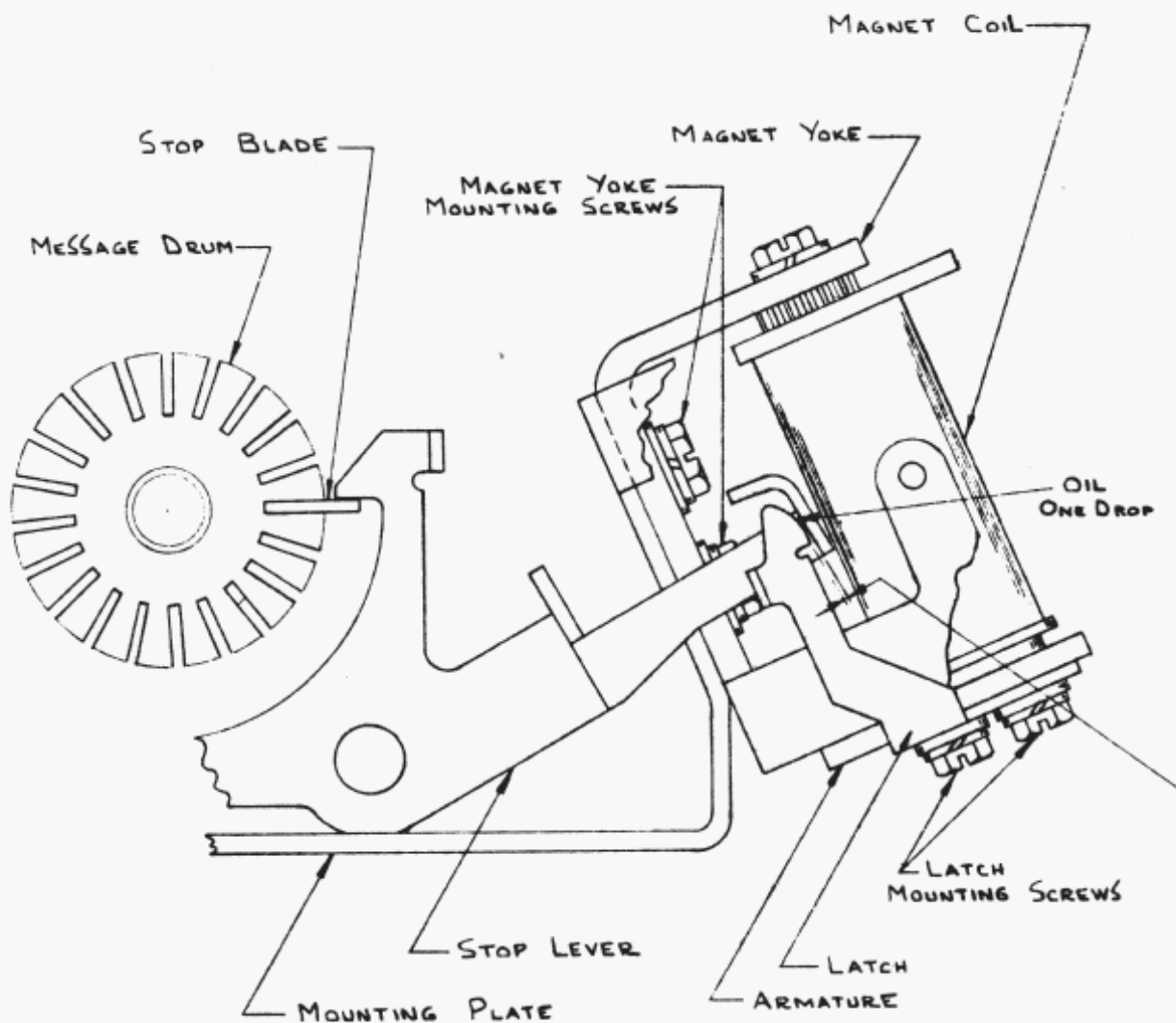

STOP LEVER LATCH

REQUIREMENT:

WITH THE ARMATURE HELD AGAINST THE MAGNET CORE— AND THE STOP LEVER HELD IN ITS EXTREME COUNTER-CLOCKWISE POSITION THERE SHOULD BE .002" TO .007" CLEARANCE BETWEEN THE STOP LEVER AND ITS LATCH. THERE SHOULD ALSO BE A MINIMUM OF .002" CLEARANCE BETWEEN THE STOP LEVER AND ITS LATCH THROUGHOUT THE COMPLETE TRAVEL OF THE STOP LEVER.

TO ADJUST:

POSITION THE LATCH BY MEANS OF ITS TWO MOUNTING SCREWS.

FIGURE 11

SENSING LEVER SPRINGSREQUIREMENT

WITH THE MECH. IN STOP POSITION
AND THE MESSAGE DRUM REMOVED
MIN. $\frac{1}{4}$ OZ. MAX. $1\frac{1}{4}$ OZS.
TO START EACH LEVER MOVING

DETENT LEVER SPRINGREQUIREMENT

WITH THE MECH. IN STOP POSITION
AND THE MESSAGE DRUM REMOVED
MIN. 22 OZS. MAX. 26 OZS.
TO START LEVER MOVING

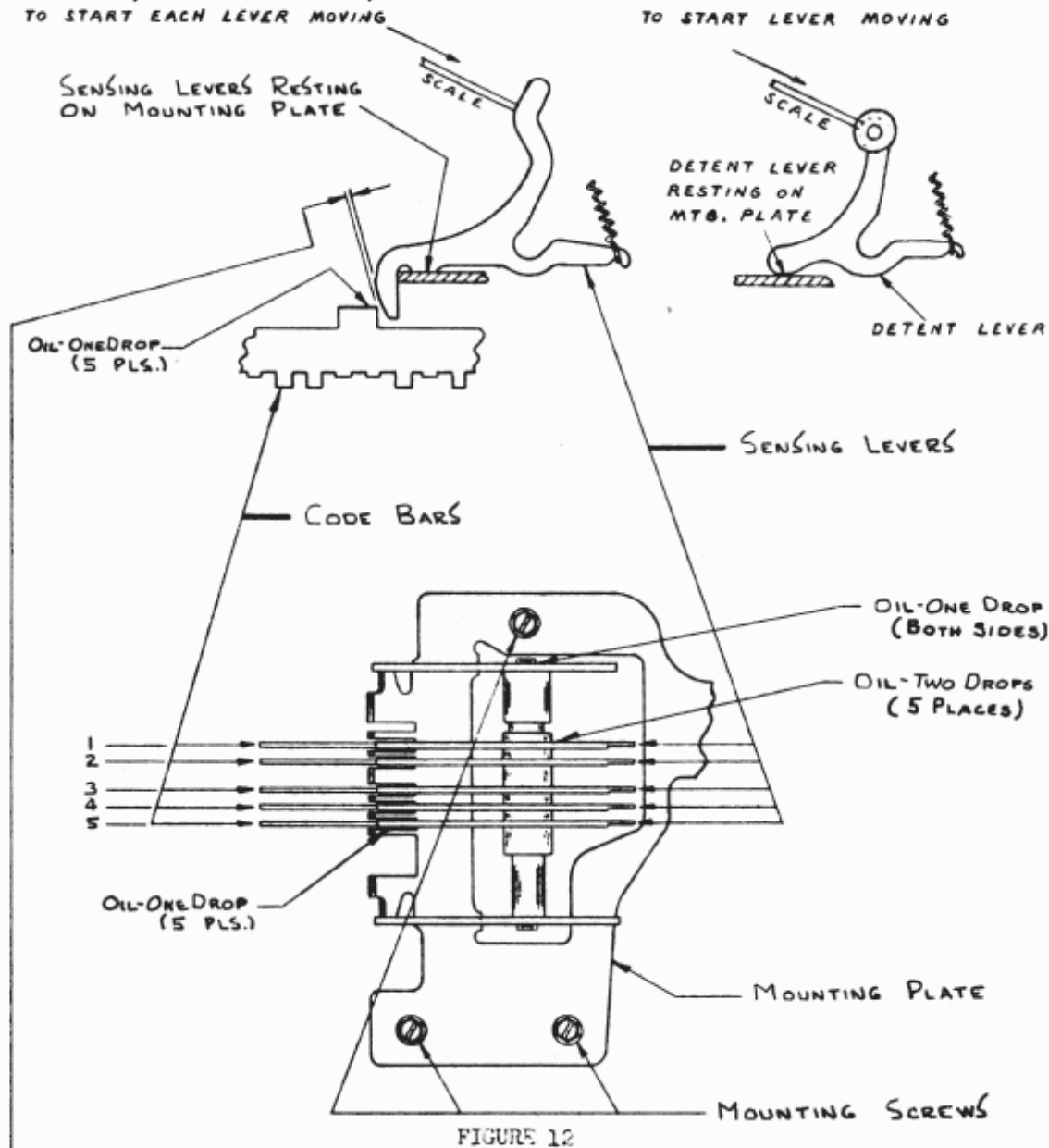
CHARACTER GENERATOR MOUNTING PLATEREQUIREMENT:

SIGNAL GENERATOR CLUTCH DISENGAGED. (1) SENSING LEVERS CENTRALLY LOCATED ON CODE BARS SO THAT EACH LEVER RESTS ON THE FULL WIDTH OF ITS ASSOCIATED CODE BAR. (2) CLEARANCE BETWEEN SHOULDERS OF CODE BARS NO. 1 NO. 5 AND THEIR ASSOCIATED SENSING LEVERS.
MIN. .002 INCH
MAX. .012 INCH

TO ADJUST:

POSITION THE MOUNTING PLATE WITH THE THREE MTG. SCREWS LOOSENED. THIS ADJUSTMENT IS FACILITATED BY REMOVING THE MESSAGE DRUM AND DRIVE PLATE ASSEMBLY FROM THE MECHANISM.

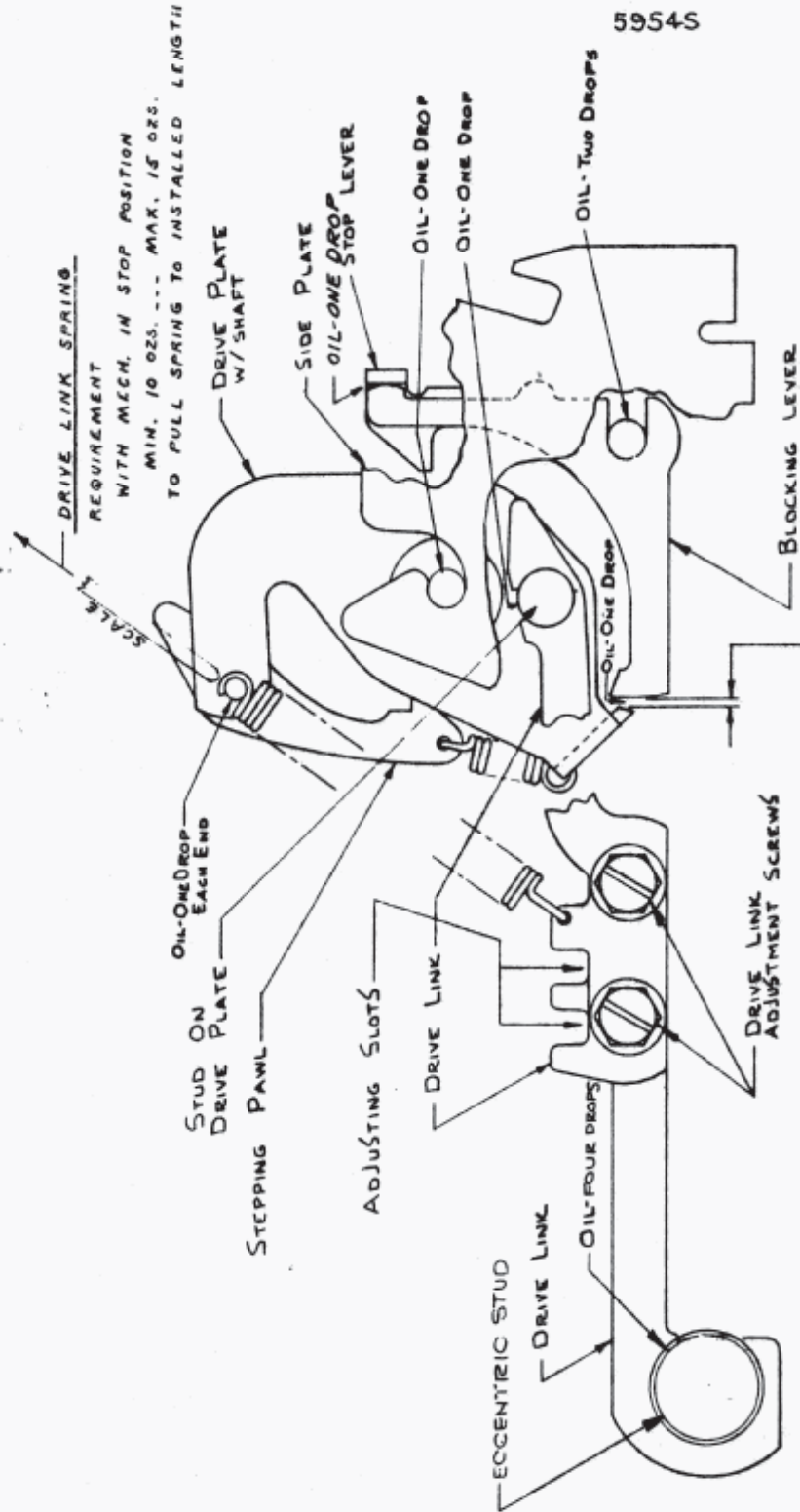

DRIVE LINK

REQUIREMENT:

- (1) KEYBOARD MECHANISM: SIGNAL GENERATOR CAM ECCENTRIC AND ARM HOLDING CODE BAR BAIL IN EXTREME RESET POSITION TO THE LEFT.
- (2) PERFORATOR MECHANISM: PERFORATOR RESET LEVER HOLDING CODE BAR BAIL IN EXTREME RESET POSITION TO THE LEFT.

THERE SHOULD BE .002" TO .007" CLEARANCE BETWEEN THE DRIVE PLATE EXTENSION AND THE BLOCKING LEVER.

TO ADJUST:

POSITION THE TWO DRIVE LINKS RELATIVE TO EACH OTHER BY MEANS OF THE ADJUSTING SLOTS AND SCREWS.

FIGURE 13

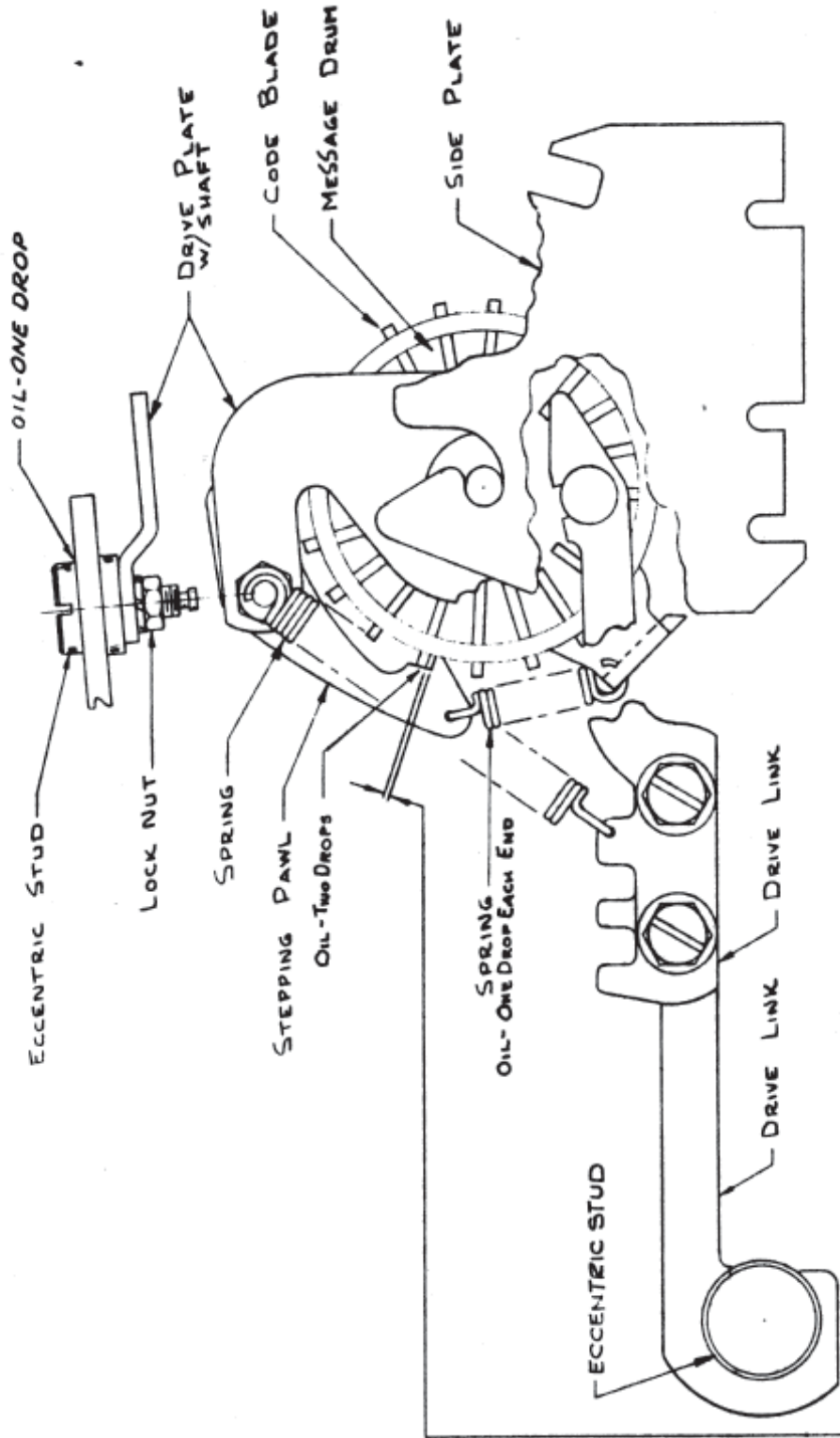

STEPPING PAWL REQUIREMENT:

MESSAGE DRUM IN FULLY DETENTED POSITION. SIGNAL GENERATOR CAM AND ARM HOLDING CODE BAR BAIL IN EXTREME "RESET" POSITION TO THE LEFT. THERE SHOULD BE .018" TO .030" CLEARANCE BETWEEN THE STEPPING PAWL AND ANY CODE BLADE.

To Adjust:

POSITION THE ECCENTRIC STUD WITH ITS LOCK NUT LOOSENED SO THAT ITS HIGH POINT IS TOWARD THE TOP.

FIGURE 14

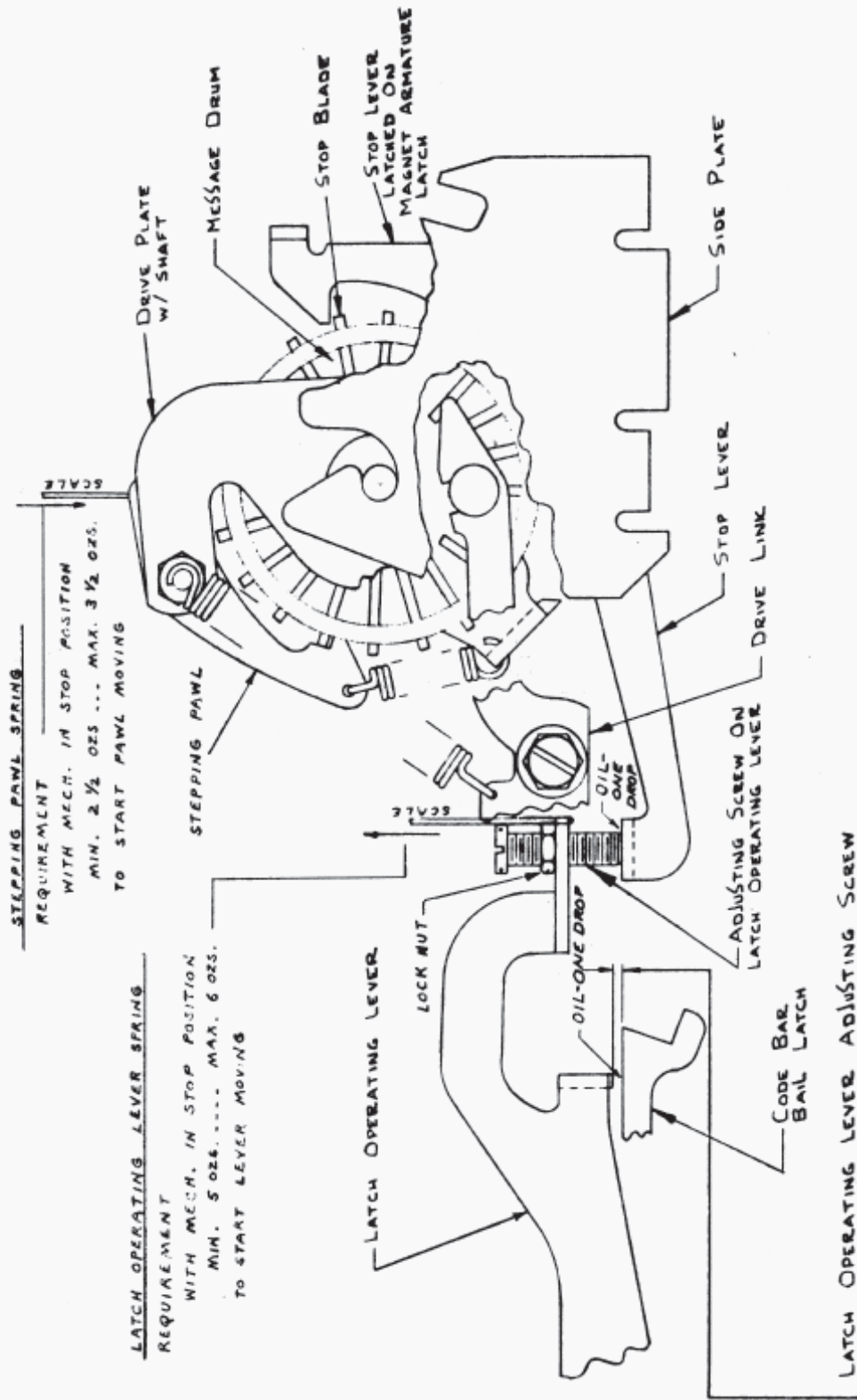

FIGURE 15