

INSTRUCTIONS FOR INSTALLING MODIFICATION KITS (172625, 176181 THROUGH 176197, 178568 THROUGH 178584, 306686 THROUGH 306702, 153926) TO CONVERT A MODEL 28 OR 35 FRICTION FEED PRINTER SET TO A SPROCKET FEED PRINTER SET AND FOR REPLACING THE 153771 THROUGH 153787 GUIDE BRACKET USING THE 159356 MODIFICATION KIT

1. GENERAL

a. The 172625 modification kit contains common parts necessary for all widths of paper to convert a Model 28 or 35 Page Typing Unit from friction feed to sprocket feed. The 172625 modification kit which replaces the 152316 modification kit consists of:

10	2191	Lockwasher	1	153686	Bearing, Sleeve (right)
1	3640	Lockwasher	1	153687	Bearing, Sleeve (left)
3	8330	Washer, Flat	1	153689	Gear, Spur - 33T
1	55063	Spring	1	153690	Gear, Spur - 28T
1	76800	Spring	1	153692	Gear, Spur - 33T
1	80848	Spring	22	195855	Pin
4	110434	Screw	1	157979	Detent, Toggle Link
8	110743	Lockwasher	1	153697	Bracket
8	125011	Washer, Flat	1	153698	Cam, Feed (left)
1	128357	Ring, Retainer	1	153699	Cam, Feed (right)
1	151660	Screw	1	332258	Shaft
1	150436	Bushing	2	153794	Plate, Adjusting
2	151346	Screw	3	153799	Screw
3	151629	Nut	1	153810	Ribbon Guide
3	151630	Screw	2	153839	Screw
1	151632	Screw	2	154290	Ring "O"
1	151637	Screw	2	154358	Hub, Platen
1	151657	Screw	1	154519	Latch
1	152893	Screw	1	155565	Arm (right)
1	153676	Bail, Detent	1	155566	Arm (left)
1	153678	Bracket (with shaft)	1	155896	Finger, Paper (left)
1	153682	Bracket (right)	1	155897	Finger, Paper (right)
1	153683	Bracket (left)	1	326007	Clamp
2	153685	Arm, Stripper	1	163959	Spring, Tension

NOTE

(For conversion from friction to sprocket) friction feed units equipped with the 179199 lever also require that this lever be replaced with a 163957 lever. This lever is not furnished and must be ordered separately.

b. The 176181 through 176197 modification kits are intended for standard Model 28 units. While the 178568 through 178584 modification kits may be used for either Model 28 or 35 Wall Mounted units. The 306686 through 306702 modification kits are intended for standard Model 35 units.

NOTE

For purposes of brevity the 176181 through 176197, 178568 through 178584, and 306686 through 306702 modification kits will only be referred to as the "various paper width modification kits" through the remainder of this specification.

c. The various paper width modification kits when used in conjunction with the 153926 and 172625 modification kits, permit conversion of a Model 28 or 35 Friction Feed Printer Set into a sprocket feed printer set, capable of accommodating a particular width of continuous superfold form stationery depending on the specific paper width modification kit selected. The customer must also order the appropriate paper tray for the paper width he wishes to use. (See Table 2.)

d. The various paper width modification kits consist of the parts listed in Table 1.

e. The 159356 modification kit (included in the 172625 modification kit) replaces the 153771 through 153787 guide bracket on a Model 28 Sprocket Feed Typing Unit. This kit permits the typed copy to be viewed as it is being typed.

f. The 159356 modification kit consists of:

4	110434	Screw	1	155566	Arm - Left
2	110743	Lockwasher	1	155896	Finger - Left
4	125011	Washer, Flat	1	155897	Finger - Right
1	155565	Arm - Right			

g. The 153926 modification kit is required to adapt a Model 28 Cabinet to handle superfold form stationery. The 153926 modification kit consists of:

3	2191	Lockwasher	1	80481	Stud
1	3598	Nut	2	151658	Screw
3	7002	Washer, Flat	1	153830	Guide, Form
1	7015	Plate, Nut	1	153833	Guide, Bracket

h. The 153905 (for units not equipped with the automatic CR-LF feature) or 153914 (for units equipped with the automatic CR-LF feature) modification kit is required to change the spacing feed for handling stationery less than 8-1/2 inches in width. (See Specification 5816S.)

i. The 152349** (Model 28) or the 192260** (Model 35) paper supply box and form accumulating shelf (for use only with floor cabinets), while not required for the conversion, will simplify handling of continuous superfold form stationery. (See Specification 5809S). The double asteriks (**) designates a two-letter suffix which indicates the paint finish. The following four standard wrinkle finishes are now available. Note: 192260 comes in HA to HZ smooth finish.

AA - Black	AC - Light Brown
AB - Gray-Green	AD - Dark Brown

j. For part numbers referred to and for parts ordering information see Teletype Model 28 Printer Parts Bulletin 1149B.

2. INSTALLATION

NOTE

References made to left or right, up or down, front or rear, etc, apply to unit in its normal operating position as viewed from the operator's position in front of the unit unless otherwise specified.

a. 172625 (with a 176181 through 176197, 178568 through 178584 or 306686 through 306702 (one required) modification kit, and with a 153726 through 153729, or 176911 through 176914 (one required) paper tray.

(1) Remove the typing unit from the printer set, if previously mounted therein.

(2) Remove the type box and ribbon spools. Remove the 150907 paper spindle if changing from friction to sprocket feed.

(3) Remove and discard the following parts from the right rear side frame in the order listed:

1	151346	Screw		3598 or	
	153839	or	2	95030	Nut
1	150040	Screw	2	125015	Spacer
	153841	or	1	150904	Block
1	151693	Screw	1	85407	Spring (if present)
3	2191	Lockwasher	1	150935	Plate (if present)

(4) Remove and discard the following parts from the left rear side frame:

1	151346	Screw (if present)	2	125015	Spacer
1	74798	Screw (if present)		3598 or	
1	3598	Nut (if present)	2	95030	Nut
1	2191	Lockwasher	1	150903	Block
	151721	or	1	85407	Spring (if present)
2	151642	Screw	1	150935	Plate (if present)

(5) Remove and discard the following paper straightener parts:

1	151686	Screw	2	124681 or	
1	110743	Lockwasher	4	73894	Screw
1	125011	Lockwasher	1	151686	Screw
1	150816	Lever	1	110743	Lockwasher
1	150815	Bushing	1	125011	Washer
1	74701 or		1	150816	Lever
	31636	Spring	1	150815	Bushing
1	150992	Stud	1	74701 or	
1	110743	Lockwasher		31636	Spring
1	152831	Clip	1	150992	Stud
1	152832	Shaft	1	110743	Lockwasher
	153634 or		1	152831	Clip
2	150683	Collar			

(6) Remove the following parts located above the plate; discard all except those marked "(retain)":

1	72468	Spring	1	150826	Paper Finger, Left
1	151637	Screw (retain)	1	150803	Flat Spring
1	110743	Lockwasher (retain)	1	150804	Paper Finger, Right
1	125802	Washer (if present)	1	150803	Flat Spring
1	125011	Washer (retain)	1	150685	Plate w/Shaft
1	151703	Pin			

(7) Remove the following parts from the upper left frame:

Retain the following for reuse
in Paragraph 2.a.(20).

1	151630	Screw
1	2191	Lockwasher
1	150961	Bushing

Discard the following:

1	150900	Detent Bail
1	150969	Torsion Spring

Note: Special units (LP68 and LP111) use a 164220 Torsion Spring, which should be retained and reused.

(8) Remove the platen assembly as follows, discard the platen assembly, and retain the other parts for reuse.

	151073 or		2	151073 or	
1	110434	Screw	2	110434	Screw
1	110743	Lockwasher	2	110743	Lockwasher
1	150720	Right Retainer	1	150719	Left Retainer
					Platen Assembly

(9) Remove and discard the following paper guide parts:

4	151692	Screw	1	152539	Guide
4	2191	Lockwasher	1	150840	Guide Bracket

2	151657	Screw	2	3598	Nut
2	2191	Lockwasher			

(10) Remove the 119652 retainer rings at the upper end of the 150386 and 150387 ribbon drive links for access to the following parts to be removed from the right frame. Discard all the following parts except those marked "(retain)":

	151657 or		1	2191	Lockwasher
4	151658	Screw (retain)	1	150436	Bushing
4	2191	Lockwasher (retain)	1	150276	Lever
2	119651	Retainer Ring	1	125015	Washer
1	150270	Link	1		Pressure Roller Assembly
1	151657	Screw			

(11) Replace the 152871 line feed bar bell crank spring with the 80848 spring.

(12) Mount the 153697 bracket, using the four mounting holes vacated by the pressure roller assembly with the four 151657 or 151658 screws and 2191 lockwashers previously removed.

(13) Replace 150934 or 153800 ribbon reverse detent cam, whichever is present, with the 157979 toggle link detent as follows:

(a) Rotate the printer shaft so that the ribbon feed units are in the maximum upper position.

(b) Remove the 3599 nut, 110743 lockwasher, 150355 spur gear, and 119651 retainer ring from the 152582 shaft. Remove and retain the two 1293 screws in the detent cam. Pull the shaft out of the right side frame to permit removal of the detent cam. Discard the detent cam.

(c) Install the 157979 toggle link detent on the 152582 shaft so that the toggle link side faces toward the right side of the printer and fasten in position with the two 1293 screws. Replace the 152582 shaft, 119651 retainer ring, 150355 spur gear, 110743 lockwasher, and 3599 nut.

(14) Replace the 150666 idler gear with the 153690 gear.

(15) Install the following parts on the rear typing unit frames:

1	153682	Right Bracket	1	153683	Left Bracket
1	153794	Plate	1	153794	Plate
1	151630	Screw, Hex	2	151630	Screw, Hex
1	151632	Screw, Hex	2	2191	Lockwasher
2	2191	Lockwasher			

(16) Assemble the platen as follows:

(a) Slip the 153692 spur gear on the 332258 platen shaft. Secure with the 151346 screw and 2191 lockwasher. Slip on the 153687 bearing sleeve with the groove toward the gear.

(b) For the 172625 modification kit, assemble the 154290 "O" ring to the groove in the 154358 platen hub. Insert the 195855 pins (11) and position the pins (with the slot facing the pin side of the hub) to accept the cam, place a light coating of grease on the surface of the cam which contacts the pins, recheck position of the pins before proceeding to insert cam.

(c) Press the 153698 left cam into the greased hub. When the cam is fully seated it should be flush with the projecting hub. Do not force the cam in. If it does not go in freely repeat instructions from Paragraph 2.a.(16)(b). Add the 153689 spur gear, flat side toward the hub. Fasten with three 153799 screws, 110743 lockwashers, and 125011 washers. Wipe off excessive grease.

(d) Slip the sprocket assembly over the 332258 platen shaft and fasten with a 151346 screw, and 2191 lockwasher. Slip the 176221 through 176237 platen cylinder (one required) over the shaft and force it over the "O" ring against the stop on the platen hub.

NOTE

Apply a light film of oil on the "O" ring to facilitate assembly.

(e) Assemble the right hand sprocket as described in Paragraph 2.a.(16)(b) and (c), using the following parts and lining up the cam with the letter "R:" assemble to the shaft:

	153700 or		1	152893	Screw
1	154358	Hub and	1	3640	Lockwasher
		154290 "O" Ring	1	151629	Nut
11	195855	Pin	1	151660	Screw
1	153699	Right Cam	1	2191	Lockwasher
1	326007	Clamp	1	8330	Flat Washer

Place the 153686 right bearing sleeve on the shaft with the chamfer or "O" (stamped on the side of the bearing, on older units) facing the end of the shaft.

NOTE

The bearings are not concentric (like the 150714 bearings on friction feed units) and it is possible to install the 153686 bearings incorrectly. The wide part of each eccentric bearing should be toward the front of the unit.

(17) Install the platen assembly in the typing unit. Cam yokes must point up, and bushings must be aligned so that the rounded portion of the slot goes into the slot in the typing unit frames.

(18) Assemble the following platen retainer parts:

1	150719	Left Retainer	1	150720	Right Retainer
3	151073	Screw	1	125011	Washer
3	110743	Lockwasher	1	110743	Lockwasher
1	151637	Screw			

(19) Install the following paper finger parts:

1	155565	Right Arm	1	2191	Lockwasher
1	155566	Left Arm	2	2191	Lockwasher
1	155897	Right Paper Finger	2	8330	Washer
1	155896	Left Paper Finger	2	151629	Nut
4	110434	Screw	2	153685	Arm w/Hub
4	110743	Lockwasher	1	153678	Plate w/Shaft
4	125011	Washer	1	128357	Retainer
2	153839	Screw	1	55063	Spring
1	154519	Latch	1	151657	Screw
1	150436	Bushing	1	76800	Spring

(20) Install the following platen detent parts:

1	153676	Detent Bail	1	2191	Lockwasher
1	163959	Torsion Spring	1	150961	Bushing
1	151630	Screw			

Note: Units with the improved manual platen line feed use a 163959 Torsion Spring, and do not need the 163959 Torsion Spring furnished as part of the kit.

(21) Clip in the 153726 through 153729 or 176911 through 176914 (one required) paper tray.

(22) Move the type box carriage to its extreme right-hand position. Hold the code bars in the marking position and rotate the main shaft so that the type box is in its uppermost position. Remove the retainer ring from the stud in the right-hand end of the type box carriage link and disengage the link from the carriage. Rotate the printer shaft so that the type box carriage is in its lowest position. Hold the ribbon guide forward and the ribbon reverse lever back and pull the carriage toward the right to disengage it from the carriage track. Replace the 152501 ribbon guide (if unit so equipped) with the 153810 ribbon guide furnished. Reassemble in the reverse order.

(23) Replace the ribbon spools and the type box.

(24) Substitute the 153652 through 153667 or 178551 through 178567 form guide (one required) included in the 176181 through 176197 or 178568 through 178584 (one required) modification kit, for the paper guide fastened to the lip of the small console lid or wall mounted cover. For kits 306686 through 306702 see Table 2. Secure with same mounting screws.

b. 176181 through 176197, 178568 through 178584 or 306686 through 306702 (one required) modification kit when changing from one width of stationery to a different width on sprocket feed printers.

NOTE

When using paper less than 4-1/4 inches in width, cut off one of the paper finger extensions; preferably the left, flush with the inside edge of the U-Form so that the remainder of the part will straddle the sprocket pins.

(1) Follow procedure in Paragraphs 2.a.(1), (2).

(2) Remove the 153726 through 153729, or 176911 through 176914, or 304772 through 304775 paper tray. On Model 35 units equipped with paper alarm parts, remove and retain the paper alarm parts prior to removing the paper tray.

(3) Remove the following paper finger parts:

1	76800	Spring	55063	Spring
1	155565	Arm, Right (w/Paper Finger)	1 128357	Retainer
1	155566	Arm, Left (w/Paper Finger)	2 153685	Stripper
			1 153678	Plate w/Shaft

(4) Remove and retain the following platen retainer parts:

2	151073	Screw	1 151685	Screw
2	110743	Lockwasher	1 153688	Eccentric
1	150719	Left Retainer	1 125011	Washer
1	151073	Screw	1 110743	Lockwasher
1	110743	Lockwasher	1 150720	Right Retainer

Remove the platen assembly from the typing unit.

(5) Disassemble the platen in the following order:

1	153686	Right Bearing Sleeve	Loosen 1179 Clamp Screw and remove Right Sprocket Hub Assembly and the present Platen Cylinder.
1	151346	Screw	
1	2191	Lockwasher	
1	7002	Washer	

(6) Replace the present platen cylinder with the platen cylinder in the specific modification kit.

(7) Reassemble the platen assembly by reversing the order used in removing it.

(8) Follow procedure in Paragraph 2.a.(18).

(9) Assemble the following platen retainer parts:

1	150719	Left Retainer	1	150720	Right Retainer
2	151073	Screw	1	151073	Screw
1	110743	Lockwasher	1	153688	Eccentric
1	151685	Screw	1	125011	Washer
2	110743	Lockwasher	1	110743	Lockwasher

(10) Follow procedure in Paragraphs 2.a.(19), (21), (23).

(11) Follow procedure in Paragraph 2.a.(24).

c. 153926 modification kit

(1) Remove the typing unit from the cabinet.

(2) Remove the following parts which seal the paper emission slot in the cabinet. These parts are located below the cabinet terminal block and should be retained for future reconversion.

Old Style

2	6345	Nut	1	152797	Plate, Retainer
2	2191	Lockwasher	1	151532 or	
2	7002	Washer		192116	Cover w/Plate, Form Slot

New Style

1	344394	Form Slot Insert			
---	--------	------------------	--	--	--

(3) Install the 153926 modification kit as shown in Teletype parts bulletin 1149B.

NOTE

If the 153926 modification kit is installed into Cabinets LAC200** or LAC201** drill a second hole (.161" diam. - No. 20 drill) to mount the 153833 guide bracket. Use the 7015 nut plate as a template for locating this hole.

(4) Remove the 151545 paper guide mounted to the small lid of the cabinet and in its place install the 153652 through 153667 form guide furnished with the typing unit or with the 176181 through 176197 modification kit (one required).

d. 159356 modification kit

(1) Remove the 153771 through 153787 guide bracket by removing the 151073 screws and 110743 lockwashers, retain the two lockwashers.

(2) Loosen the 153839 screws mounting the 153721 and 153722 arms; remove the 128357 retainer ring, and the 55063 and 76800 springs from the 153678 bracket with shaft. Retain all parts.

(3) Remove the 153678 bracket with shaft, two 153685 strippers and 153721 and 153722 arms from the unit. Retain the bracket and strippers.

(4) Remove the 153839 screw, 8330 flat washer, 2191 lockwasher and 151629 special nut from the 153721 and 153722 arms, and assemble them correspondingly to the 155565 and 155566 arms.

NOTE

When using paper less than 4-1/4 inches in width, cut off one of the paper finger extensions; preferably the left, flush with the inside edge of the U-Form so that the remainder of the part will straddle the sprocket pins.

(5) Assemble the 155896 paper finger to the 155566 arm with two 110434 screws, 110743 lockwashers and 125011 flat washers, and assemble the 155897 paper finger to the 155565 arm with two 110434 screws, 110743 lockwashers and 125011 flat washers.

(6) Assemble the 128357 retainer ring, and the 55063 and 76800 springs to the 153678 bracket with shaft.

3. ADJUSTMENTS AND LUBRICATION

For standard adjustment and lubrication procedure refer to standardized information (for other than Bell System see Teletype Bulletin 217B).

4. MAINTENANCE

a. The following instructions are provided for lubrication of the sprocket hub assemblies which house the sprocket pins and cams or for replacement of pins or springs. Detailed instructions may be obtained by reversing assembly instructions in Paragraph 2.a.(18).

- (1) Remove the guide bracket assembly.
- (2) Remove the platen assembly.
- (3) Remove sprocket hub assemblies from platen assembly.
- (4) Remove the 157286 clamp and 153699 cam from assembly.

- (5) Should a pin require replacement, replace the defective pin.
- (6) The surface of the cam which contacts the pins should be given a light coat of grease.
- (7) Reverse procedure in Paragraphs 4.a.(4) and (5).
- (8) Repeat Paragraphs 4.a.(5) through (8) with left sprocket assembly.
- (9) Reverse Paragraphs 4.a.(1) through (3).
- (10) Refer to NOTE in paper guide adjustment.

6. PAPER HANDLING INFORMATION

The Model 28 Sprocket Feed Typing Unit is capable of reliably handling up to 12 copies of stapled continuous form stationery or up to six copies of unstapled form stationery.

a. For stapled stationery, place the form supply box on the floor behind the cabinet or on the shelf provided in the 152349** paper supply box and form accumulating shelf.

b. For unstapled stationery, place the form supply box on a platform not more than 18 inches below the paper admission slot or on the shelf provided in the 152349** paper supply box and form accumulating shelf.

* * *

5792S

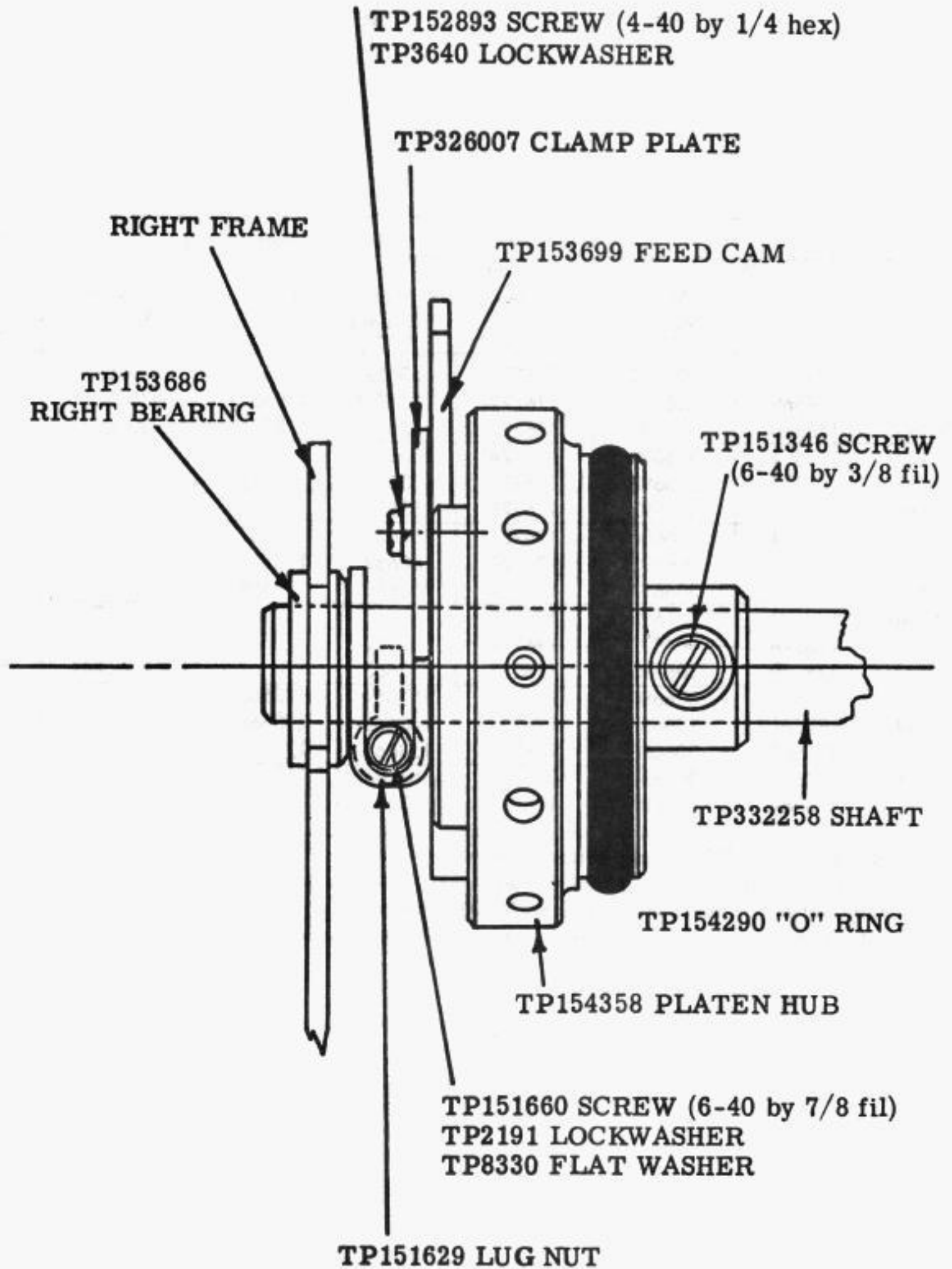

NEW PARTS AND NEW MOUNTING ARRANGEMENT

Figure 1

Modification Kits			Includes Rubber Platen	Includes Form Guides			For Paper Width (In Inches)
<u>M28 Standard</u>	<u>M28 or 35 Wall Mounted</u>	<u>M35 Standard</u>		<u>M28 Standard</u>	<u>M28 or 35 Wall Mounted</u>	<u>M35 Standard</u>	
176181	178568	306702	176221	153652	178551	306685	9
176182	178569	+306701	176222	153653	178552	306684	8-1/2
176183	178570	306700	176223	153654	178553	306683	8
176184	178571	306699	176224	153655	178554	306682	7-1/2
176185	178572	306698	176225	153656	178555	306681	7
176186	178573	306697	176226	153657	178556	306680	6-1/2
176187	178574	306696	176227	153658	178557	306679	6-3/8
176188	178575	306695	176228	153659	178558	306678	6-1/4
176189	178576	306694	176229	153660	178559	306677	6
176190	178577	306693	176230	153661	178560	306676	5-3/4
176191	178578	306692	176231	153662	178561	306675	5-1/2
176192	178579	306691	176232	153663	178562	306674	5
176193	178580	306690	176233	153664	178563	306673	4-1/2
176194	178581	306689	176234	153665	178564	306672	4-5/16
176195	178582	306688	176235	153665	178565	306672	4-1/4
176196	178583	306687	176236	153666	178566	306671	4
176197	178584	306686	176237	153667	178567	306670	3-5/8

+Replaces the 192210 modification kit formerly furnished for early Model 35 units. The actual parts comprising both of these modification kits are identical. The modification kit part number and the 192208 form guide part number were changed to have this kit available in a series of unbroken part numbers.

TABLE 1

NOTE

Each kit must be used in association with a particular paper tray which is mounted in the typing unit. The paper trays are common to a number of form widths and therefore, must be ordered separately. Tabulated below are the various widths of stationery together with the corresponding modification kits and paper trays.

Paper Widths	Modification Kit			Paper Tray		
	Standard (M35)	Standard (M28)	Wall Mounted (M28 or 35)	Standard (Old Style)	Wall Mounted	Standard (New Style)
9 Inches	306702	176181	178568	153727	176912	304773
8-1/2 Inches	306701	176182	178569	153726	176911	304772
8 Inches	306700	176183	178570	153727	176912	304773
7-1/2 Inches	306699	176184	178571	153726	176 911	304772
7 Inches	306698	176185	178572	153727	176912	304773
6-1/2 Inches	306697	176186	178573	153726	176911	304772
6-3/8 Inches	306696	176187	178574	153728	176913	304774
6-1/4 Inches	306695	176188	178575	153729	176914	304775
6 Inches	306694	176189	178576	153727	176912	304773
5-3/4 Inches	306693	176190	178577	153728	176913	304774
5-1/2 Inches	306692	176191	178578	153726	176911	304772
5 Inches	306691	176192	178579	153727	176912	304773
4-1/2 Inches	306690	176193	178580	153726	176911	304772
4-5/16 Inches	306689	176194	178581	153729	176914	304775
4-1/4 Inches	306688	176195	178582	153728	176913	304774
4 Inches	306687	176196	178583	153727	176912	304773
3-5/8 Inches	306686	176197	178584	153726	176911	304772

+The new style paper tray provides greater stunt box cable clearance, and also has two mounting holes for mounting paper-out, and low paper alarm modification kits on Model 35 units. The paper trays are common to both Model 28, and 35 units.

TABLE 2