

INSTRUCTIONS FOR MODIFYING A MODEL 15 PRINTER FROM 60 W.P.M.
OPERATION TO EITHER 75 W.P.M. (USING THE 96535 OR 96536
MODIFICATION KIT) OR 100 W.P.M. (USING THE 110891 OR 110892
MODIFICATION KIT) OPERATION

1. GENERAL

NOTE: Increased maintenance and reduced operating margins can be expected of units operating at 100 W.P.M.

a. The 96535 or 96536 modification kit when installed on a Model 15 Printer equipped with a 60 cycle synchronous motor or with a 50 - 60 cycle AC series motor (governed) respectively and with the standard features listed in Paragraph 1.g. below, provides 75 W.P.M. operation.

b. The 110891 or 110892 modification kit when installed on a Model 15 Printer equipped with a 60 cycle synchronous motor or with a 50 - 60 cycle AC series motor (governed) respectively and with the standard features listed in Paragraph 1.g. below, provides 100 W.P.M. operation.

c. The 111851 modification kit is used in addition to the 110891 or 110892 modification kit for Model 15 Printer equipped with keyboard (See Specification 5498S).

d. The 96535 or 96536 modification kit consists of:

			96535	96536
1	84105	Pinion - 8T		x
1	84106	Gear - 32T		x
1	91286	Pinion - 7T	x	
1	91287	Gear - 24T	x	
1	122059	Spring	x	x

e. The 110891 or 110892 modification kit consists of:

			110891	110892
1	2605	Spring	x	x
1	6850	Crank, Bell	x	x
1	# 6971	Lever, (Marked C)	x	x
1	71696	Scale	x	x
1	73611	Wick	x	x
27	# 74185	Bar, Pull	x	x
1	74553	Wick	x	x
1	93729	Wick	x	x
* 1	98229	Washer, Felt	x	x
* 2	101657	Washer, Felt	x	x
1	#110352	Modification Kit (listed in Specification 5469S)	x	x
1	110869	Pinion-16T	x	
1	110870	Gear-42T	x	
1	110871	Latch	x	x
1	110872	Spring	x	x
1	110873	Cam	x	x
1	110874	Pinion-14T		x
1	110875	Gear-43T		x
1	110878	Spring	x	x
1	110880	Spring	x	x
1	114107	Spring	x	x
1	114231	Pull Bar Bail Assembly (Yield Type)	x	x
1	#115823	Type Bar Backstop Assembly	x	x

NOTE: Parts marked # are factory installed on current production units. Disregard installation instructions for these parts if unit is so equipped.

f. For part number referred to and for parts ordering information see Teletype Model 15 Printer Parts Bulletin.

NOTE: On typing units which have already been converted for 100 speed using the 111929 auxiliary bail modification kit, the 74363 pull bar bail with the attached auxiliary bail parts should be removed and replaced by the 114231 pull bar bail assembly. The 111773 ribbon reverse bail and the 111774 shoulder screws may be retained but it would be preferable to obtain and use the 74390 reverse bail and the 74292 shoulder screws. For installation of the 114231 pull bar bail assembly see Paragraph 2.g.

g. The Model 15 Printers selected for this service must have the following standard features which are essential for 75 or 100 W.P.M. operation:

(1) 95380 modification kit to convert a Model 15 Typing Unit with a pulling magnet selector to a typing unit with a holding magnet selector. (See Specification 5257S included with modification kit).

(2) 111851 modification kit to convert a Model 15 Keyboard for 100 W.P.M. (See Specification 5498S included with modification kit).

(3) For 75 W.P.M., new style 8097 transmitting cam sleeve assembly which may be identified by the markings: 8097 60-75S 7.42U.

(4) Improved bearing and lubrication facilities.

(a) This feature requires the following parts:

1. 105048 modification kit for lubricating 15 Printer main shaft. (See Specification 5394S).

2. 93839 function lever bail assembly.

3. 74119 bail shaft bearing, plus 94694 felt button and 86710 oiler.

4. 91175 cam follower roller assembly.

5. 90438 felt button for lubricating the front shaft bearing on the keyboard.

6. For 75 W.P.M., two 72563 felt washers (Figure 2) one on each side of the armature lever cam on the selector cam sleeve assembly for lubricating the armature lever cam.

2. INSTALLATION (Figures 1 through 6)

*a. For changing from 60 W.P.M. to 75 W.P.M. operation:

(1) Install the gear and pinion furnished in place of the present gear and pinion.

(2) Install the 122059 clutch spring furnished in place of the 6993 clutch spring.

b. For changing from 60 W.P.M. to 100 W.P.M. operation:

(1) Remove the range scale assembly.

(a) Remove and discard the 90775 range scale, the 90774 bell crank, the 7602 trip latch spring, and the 90088 trip latch. Retain the remainder of the assembly.

(b) Assemble the 71696 range scale, the 6850 bell crank, the 110872 trip latch spring, the 110871 trip latch and the parts that were retained.

(2) Remove the main shaft assembly.

(a) Remove and discard the 74140 printing and function cam, the 6993 clutch spring and the present gear on the shaft.

*(b) Remove the 72563 felt washers from the selector cam sleeve. Install one each of the furnished 101657 felt washers on each side of the locking lever cam and install the furnished 98229 felt washer between the stop arm and the armature lever cam.

(c) Reassemble the main shaft using the 110873 printing and function cam, the 110878 clutch spring and the main shaft gear furnished.

(d) Discard the pinion on the motor and install the pinion furnished with the modification kit.

(3) Insert the 93729 wick furnished in the 114107 selector arm spring and install the 114107 selector arm spring furnished in place of the 90517 selector arm spring.

*(4) Install the 6971 (marked C) clutch throwout lever furnished, in place of the old style clutch throwout lever.

(5) Install the 110880 selector arm detent spring furnished in place of the 90510 selector arm detent spring.

(6) Insert the 74553 wick furnished in the 2605 locking lever spring and install the 2605 locking lever spring furnished in place of the 91120 locking lever spring.

(7) Insert the 73611 wick furnished in the 4708 armature lever spring.

(8) Replace the main shaft and range scale assemblies.

(9) Install the 110352 modification kit in accordance with Specification 5469S included in the modification kit.

(10) Remove the type bar carriage from the typing unit. Remove the 74185 pull bars and replace them with 74185 pull bars furnished if the latest type 74185 are not already in the unit. All new Model 15 typing units, are now equipped with the modified 74185 pull bars at the factory. An examination will reveal whether the unit being worked over is equipped with old or new style 74185 pull bars. The new style 74185 pull bar can be identified by the absence of grinding marks on the sides and the presence of a .015" radius at the base of the rack teeth. When the unit is already equipped with the new style 74185 pull bars, replacement of these pull bars with those furnished in the modification kit is optional.

(11) Install the 114231 pull bar assembly as follows:

(a) Remove and retain the 74994 bell crank mounting plate and mounting screws.

(b) Remove and discard the 74993 pull bar stripper and mounting parts.

(c) Remove and retain the 74187 pull bar guide with assembled code bars, the 74806 guide post mounting strip, and the mounting screws, washers, and lock washers.

(d) Remove and retain the right-hand 74286 bail guide and mounting screws.

(e) Remove and retain the 74292 shoulder screws, the 74721 springs, and the 74390 reverse bail.

(f) Remove the 74363 pull bar bail and transfer the 74008 rollers, 74006 bushings, 74334 lock washers, 2669 lock washers, and 112626 nuts to the yield type pull bar bail. Discard the 74363 bail.

(g) Install the 114231 bail assembly and reinstall the parts removed in Paragraphs 2.b. (11) (a), (c), (d), (e).

(h) Make the Ribbon Ratchet Shaft Gears Backlash adjustment listed in Paragraph 3.

(12) Install the 115823 type bar backstop assembly in place of the leather backstop assembly.

(13) Replace the carriage on the typing unit.

3. ADJUSTMENTS

*a. For adjusting procedure refer to standardized adjustment information. Make the following changes for 100 W.P.M. units; changes (3), (6) and (9) apply to 75 W.P.M. units.

	<u>New Requirement</u>
(1) Selector Arm Stop Detent Spring Tension	6-3/4 - 7-3/4 ozs.
(2) Armature Lever Spring Tension	22 - 26 ozs.
* (3) Selector Arm Spring Tension	1-3/4 - 2-1/4 ozs. (100 W.P.M.) 1-1/4 - 1-3/4 ozs. (75 W.P.M.)
(4) Trip Latch Spring Compression	2-3/4 - 3-1/4 ozs.
(5) Selector Clutch Torque	16 - 22 ozs.
* (6) Main Shaft Jaw Clutch Spring Tension	46 - 58 ozs. (100 W.P.M.) 32 - 42 ozs. (75 W.P.M.)
(7) Locking Lever Spring Tension	7 - 10 ozs.
(8) Ribbon Ratchet Shaft Gears Backlash	

Due to the shorter bail travel on 100 W.P.M. printers there should be a minimum of backlash in the ribbon ratchet shaft gears to insure proper ribbon feeding. To obtain this condition, tighten the 74511 friction spring on the ratchet shaft by bending the straight portion of the spring.

*(9) Selector Cam Sleeve Assembly

Make certain that the felt washers of the selector cam sleeve assembly do not interfere with the movement of the respective cam follower levers.

* * *

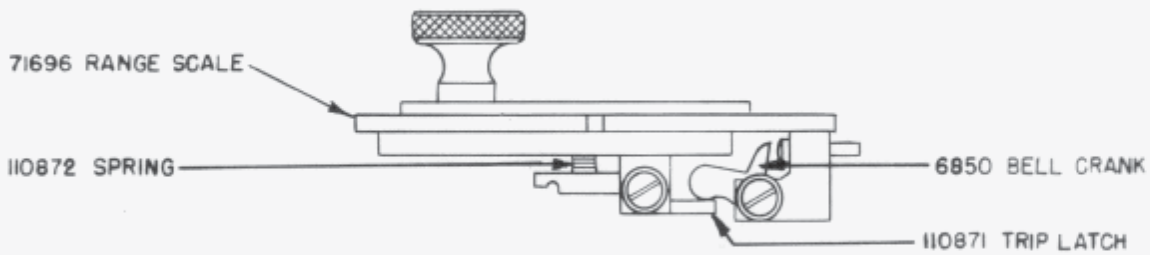

FIGURE 1

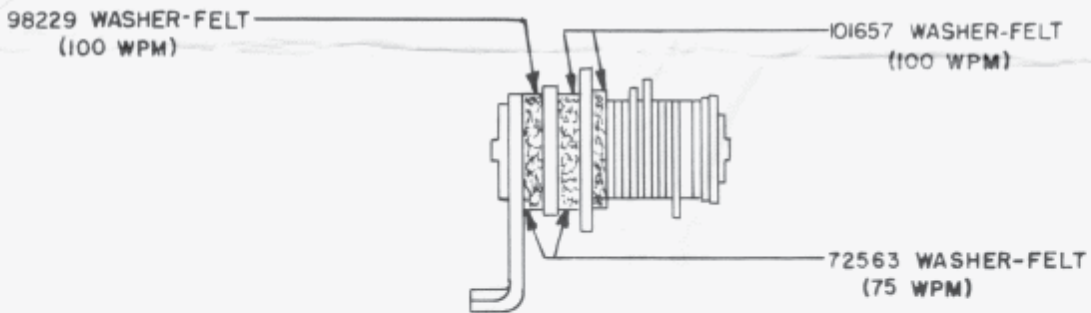

FIGURE 2



FIG. 3

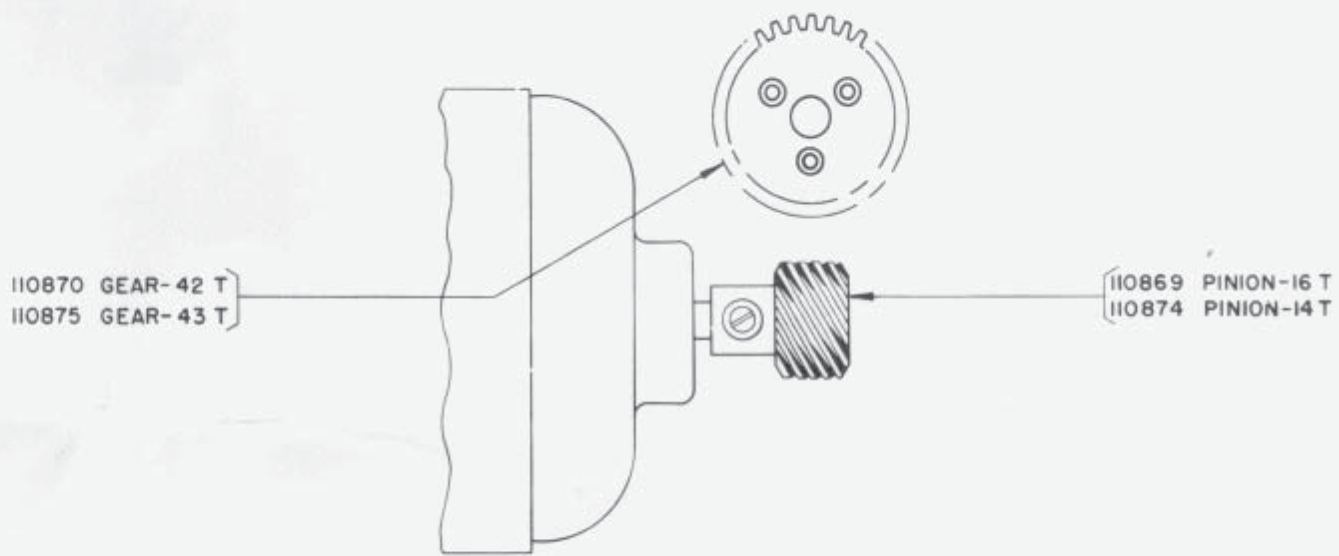

FIG. 4

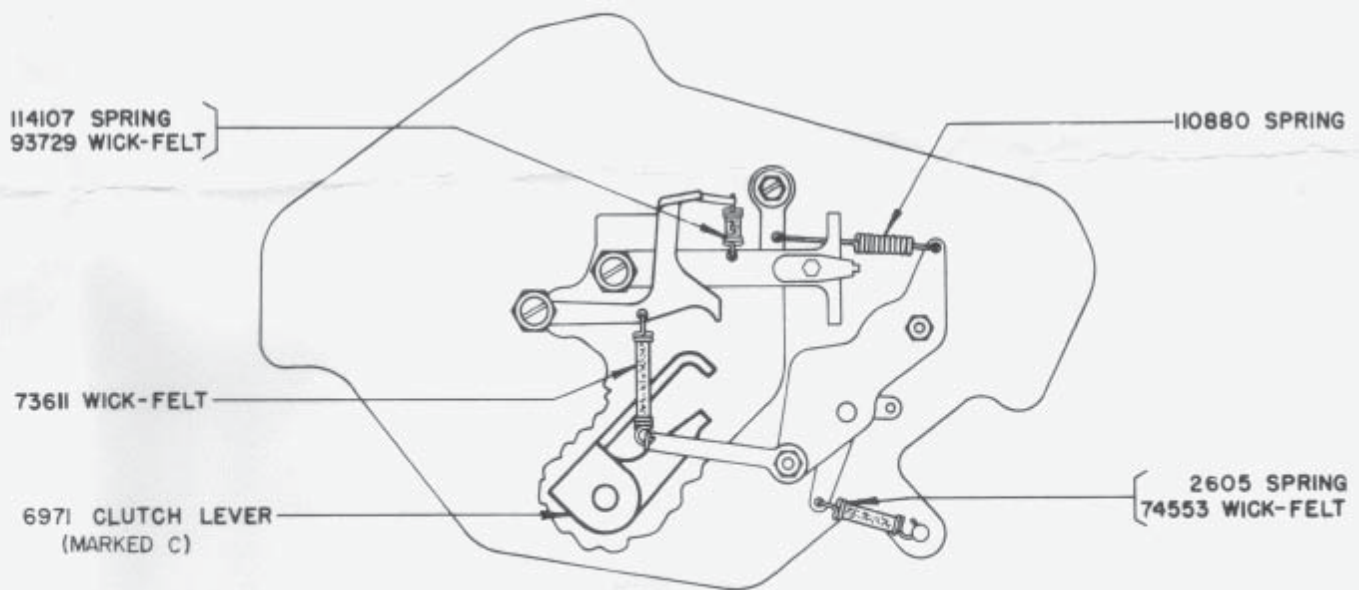

FIG. 5

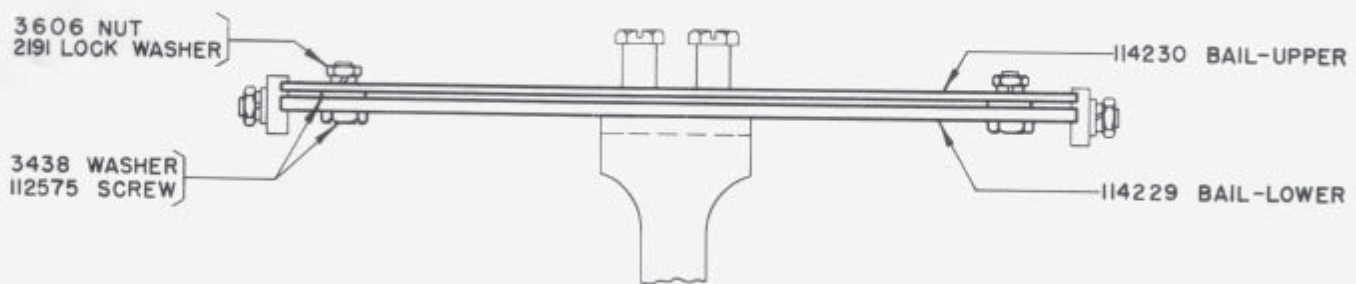

FIG. 6