

INSTRUCTIONS FOR INSTALLING THE 194236 MODIFICATION
KIT TO ADD PRINT-SUPPRESSION TO THE MODEL 35 TAPE
PRINTER (LTP800, 801) AND MODEL 35 TYPING REPERFORATOR (LPR800, 801)

1. GENERAL

a. The 194236 Modification Kit provides facilities for suppressing printing on the Model 35 Tape Printer and Typing Reperforator when certain predetermined code combinations are received. Print suppression occurs on code combinations in which the sixth and seventh bits are either both marking or both spacing.

b. The 194236 Modification Kit performs this function by preventing the print hammer accelerator from being tripped.

c. The 194236 Modification Kit consists of:

2	3640	Washer, Lock	2	151152	Screw
2	125011	Washer, Flat	1	192875	Link, Blocking

d. For parts referred to other than those listed here, refer to Teletype Parts Bulletin 1188B.

2. INSTALLATION

a. Remove the unit from its base by disconnecting the cable connector and removing the three mounting screws.

b. Secure the 192875 Blocking Link to the flange of the 192883 Ribbon Guide using the two 151152 Screws, two 125011 Flat Washers and two 3640 Lock Washers.

NOTE

Adjustments and Lubrication should be performed before the typing unit is replaced on the base.

c. Replace the unit on the base making sure the gear meshes properly. Replug cable connector and secure unit with the mounting screws.

3. ADJUSTMENTS AND LUBRICATION

a. Adjust and lubricate related equipment according to standardized information.

b. Perform the adjustment and lubrication of the 194236 Modification Kit as shown on Figure 1.

*

*

*

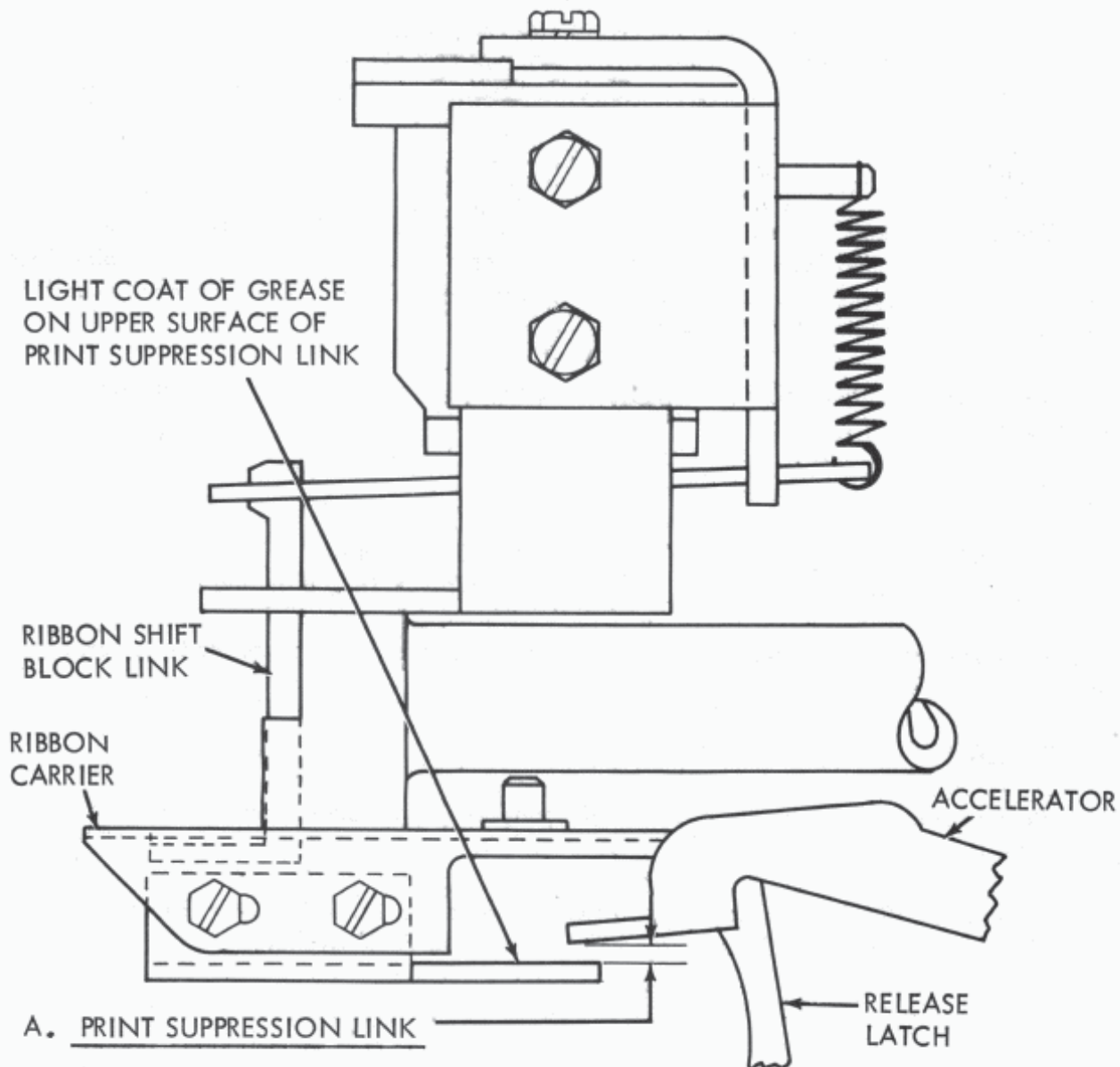

REQUIREMENT

FUNCTION CLUTCH TRIPPED AND MAIN SHAFT ROTATED UNTIL
PRINT HAMMER TRIP LEVER JUST TOUCHES PRINT RELEASE LATCH.
THERE SHALL BE

MIN. 0.020 INCH

MAX. 0.030 INCH

CLEARANCE BETWEEN THE UPPER SURFACE OF THE PRINT SUPPRESSION
LINK AND THE LOWER SURFACE OF THE PRINT HAMMER ACCELERATOR
TO ADJUST

POSITION THE PRINT SUPPRESSION LINK ALL THE WAY TO THE REAR OF
THE SLOTS ON THE RIBBON CARRIER. POSITION LINK IN VERTICAL
DIRECTION WITH MOUNTING SCREWS LOOSENED TO MEET REQUIREMENT.