

INSTRUCTIONS FOR INSTALLING THE 195022 MODIFICATION
KIT TO CONVERT FAA MODEL 28 ASR SETS WITH KEYBOARDS
LAK4 OR 25 TO CONFORM TO VSL245; KIT 195023 TO MAKE
FAA MODEL 28 ASR SETS WITH KEYBOARD LAK26 COMPATIBLE
WITH VSL245 SETS; AND KIT 195036 TO PROVIDE LINE RELAY
AND LINE SHUNT RELAY FOR AUXILIARY TYPING REPERFORATOR
(LPR) FOR FAA

1. GENERAL

a. The 195022 Modification Kit converts FAA Model 28 ASR Sets equipped with keyboards LAK4 or LAK25 to conform to VSL245.

(1) The subject Model 28 ASR Set to be converted consists of the following:

- 1 LP12RE/Modified AEY, Typing Unit
- 1 LAK4ARE/LPR10ARE (Modified) Keyboard
- 1 LESU21, Electrical Service Unit
- 1 LESU12, Electrical Service Unit
- 2 RY33, Line Relays
- 1 LBXD4, Transmitter Unit
- 1 LCXB6, Transmitter Distributor Base
- 1 LAAC206, Cabinet
- 1 160334 (Modified), Transmitter Control Unit
- 1 160335, Control Panel
- 1 160337, Mounting Rack
- 1 165344, 48 Volt Rectifier
- 1 158257, Auxiliary Cable

b. The 195023 Modification Kit provides the necessary parts and assemblies to make a Model 28 ASR Set equipped with an LAK6 (modified to LAK26) to be compatible with the VSL245 Set.

NOTE

This type of modified ASR Set uses an LPE1 in the keyboard position rather than an LPR.

(1) The 195023 Kit is essentially the same as the 195022 Kit except that the keyboard parts are not included.

c. The VSL245 Model 28 ASR Set, in addition to standard printing and operating functions, operation in accordance with FAA selective calling requirements, includes the following features:

(1) Busy Lamp and open lamp plus relays (part of transmitter control Modification Kit) to control their operation.

(2) Selective calling stunt box and page printer with print-suppress solenoid.

(3) Local-remote switch to permit local control monitoring.

(4) Transmitter Control Modification Kit which permits control of the local TD from push button or stunt box contact operation.

d. The 195036 Modification Kit provides line relay and line shunt relay for Auxiliary LPR (FAA).

(1) The 195036 Kit is for use on ASR Sets requiring an Auxiliary Reperforator in addition to a perforator (LPE) mounted in the keyboard position.

(2) The 195036 Kit provides mounting for the line relay and line shunt relay in the lower cavity of the ASR Set without the use of an LESU Container Assembly.

e. The 192022 and 192023 Kits consist of:

			<u>195022</u>	<u>195023</u>
1	179670	Mod. Kit, to Immobilize Cradle Asm.	X	X
1	179953	Mod. Kit, to Convert 160334 Transmitter Control Device to 179472	X	X
1	195017	Mod. Kit, to Convert LAK25/LPR10 to LAK28/LPR50	X	
1	195019	Mod. Kit, Typing Unit	X	X
1	195025	Sticker, Identification	X	X
1	195028	Mod. Kit, Electrical Service	X	X
1	195031	Mod. Kit, to Convert LAAC206 to LAAC241	X	X
1	195043	Sticker, Identification		X
1	195044	Sticker, Identification	X	
1	195045	Mod. Kit, to Convert LAK4ARE	X	

f. The 195036 Kit consists of:

2	153017	Nut	1	193687	Cable, Assembly
1	157230	Strap Assembly	1	195037	Mtg. Asm., Line Relay
1	160439	Bracket, Mtg.	1	195038	Relay Asm., Aux. Line Shunt
2	179484	Screw	1	195039	Cable Assembly

g. For parts ordering information see Teletype Model 28 Parts Bulletin 1167B (LPR) and Teletype Model 28 Parts Bulletin 1169B (ASR).

2. INSTALLATION (See attached Figures)

a. 195022 Modification Kit to convert FAA Field ASR Set equipped with an LAK4 or LAK25 to conform to VSL245.

(1) The 195019 Modification Kit to convert LP12 RE/Modified AEY Typing Unit to LP104RE/AHN.

(a) Remove and discard existing stunt box cable and replace with 179288 Stunt Box Cable Assembly. (Do not attach wires to LP Connector).

(b) Install the 153919 Double Connector Modification Kit per Teletype Specification 5820S. Wire per 4709WD (Stunt Box Cable to be wired to new LP Connector at this time).

(c) Remove and discard existing 151739 Stunt Box Identification Screw, and replace with 151739 Screw stamped "AHN".

(d) Remove and discard existing Teletype Code Plate and replace with 150950 Code Plate stamped "FM-LP104RE/AHN".

(2) 195045 Modification Kit to convert LAK4ARE to LAK25ARE for FAA.

(a) Assemble the six 111017 Screws and the six 151416 Nuts on the 158250 Terminal Block.

(b) Assemble the terminal block and one of the 164224 Insulators to the 158251 Nut Plate using the two 151335 Studs and the two 2191 Lockwashers.

(c) Mount the terminal block assembly (from preceding paragraph) on the LAK Keyboard in holes provided adjacent to existing terminal block numbered 1 through 6, using the 86744 Shoulder Screw and 2191 Lockwasher.

NOTE

Number 1 on the insulator should be to the rear of the keyboard. The 86744 Shoulder Screw shall be mounted in the rear mounting hole.

(d) Install the 151818 Wire Assembly on Terminals 1 and 7.

(e) Install the remaining 164224 Insulator, 151631 Screw and 2191 Lockwasher after additional wiring is completed.

(3) 195017 Modification Kit to convert LAK25ARE/LPR10ARE to LAK28ARE/LPR50ARE for FAA.

- (a) Install the 179623 Resistor Assembly per 4748WD.
- (b) Remove and discard the 158224 Auxiliary Cable Assembly and replace with the 179621 Auxiliary Cable Assembly. Wire per 4748WD.
- (c) Install the 178599 Keyboard Cable Assembly and wire per 4748WD.
- (d) Remove and discard the 161237 Cable and Connector Assembly on LPR and replace with the 179628 Cable and Connector Assembly. Install per Figure 1 and 4748WD.
- (e) Drill the three .250 Diameter Holes in the LAAC Cabinet per Figure 2.
- (f) Mount the 194922 Line Relay Mounting Bracket to the left rear inside wall of the cabinet, using the three 104074 Screws, three 35826 Flat Washers and three 3639 Lockwashers, (it may be necessary to cut away a portion of the sound proof padding on inside of cabinet before mounting the 194922 Bracket)
- (g) Mount the 179140 Auxiliary Line Shunt Relay Assembly using the two 179484 Screws and two 153017 Speed Nuts. Install per Figure 1, wire per 4748WD.
- (h) Mount the 179139 Line Relay Mounting Assembly using the two 179484 Screws and two 153017 Speed Nuts. Install per Figure 1, wire per 4748WD.
- (i) Relocate the transmitter unit line shunt relay as follows:
 - 1. Remove line shunt relay from bottom cavity of cabinet. Retain mounting hardware.
 - 2. Reinstall the line shunt relay to the left rear inside wall of the cabinet as shown in Figure 1.
 - 3. Separate the purple wire from the line shunt relay cable assembly.
 - 4. Shorten the purple wire to proper length for mounting on terminal C-40.

NOTE

Install the 72596 Terminal Lug on shortened purple wire.

- (j) Replace existing Teletype Code Plate on LAK with the 150950 Code Plate stamped FM-LAK28ARE.
- (k) Replace existing Teletype Code Plate on LPR with the 150950 Code Plate stamped FM-LPR50ARE.

- (4) 195028 Modification Kit: To convert LESU21 to LESU79 for FAA.
- (a) Remove and discard the 160333 Cable Assembly.
 - (b) Add the 179429 Cable Assembly. Wire per 4749WD.
 - (c) Unsolder and discard the 151422 Convenience Receptacle, retaining the mounting hardware. Install the 178832 Adapter Plate and the 178831 Connector Receptacle using the retained mounting hardware. Resolder the wires in accordance with 4743WD.
 - (d) Install the seven 151827 Connector Straps per 4749WD.
 - (e) Install the four 151819 Wire Assemblies per 4749WD.
 - (f) Install the 179446 Cable Assembly per 4749WD.
 - (g) Remove existing Teletype Code Plate and replace with the 150950 Code Plate stamped FM-LESU79.
 - (h) Install the 179627 Cable Assembly per 4749WD.
- (5) 195031 Modification Kit to convert LAAC206 Cabinet to LAAC241.
- (a) Modify the cabinet for full panel door as follows:
 - 1. Remove and discard the existing 158670 Right Hinged Door Panel and associated mounting hardware.
 - 2. Remove and discard the existing 159735 Left Stationary Panel and associated mounting hardware.
 - 3. Drill the six 7/32 diameter holes in bottom side of cabinet shelf per Figure 3. The 195029 Template is provided for depth location as shown in Figure 4.

CAUTION NOTE

Do not attempt to drill through template, to be used for locating purposes only.

4. Install the three 195024 Panel Mounting Brackets using the six 55323 Screws, six 3646 Lockwashers, six 44048 Flat Washers, and the three 192106 Nut Plates, per Figure 5. The 154252 Door Panel may be installed on the unit at any time.

- (b) Remove the auxiliary terminal block assemblies from the right and left inner walls of the cabinet. Discard the 160461 Brackets and the mounting hardware. (Lockwashers, Flat Washers and Nuts.)

(c) Reassemble the terminal board assemblies using the 179449 Brackets in place of the 160461 Brackets (previously used).

(d) Mount the two new terminal board assemblies as shown in Figure 6 using the six 179484 Screws and the six 153017 Speed Nuts.

(e) Install the 193685 Service Cord (PTR) per Figure 6 and 4750WD.

(f) Install the 193686 Service Cord (TD) per Figure 6 and 4750WD.

(g) Install the 193687 Service Cord (LPR) per Figure 6 and 4750WD.

(h) Install the 179431 X-Connector Cable per Figure 1 and 4750WD.

(i) Remove and discard the 160352 Control Panel Cable Assembly and replace with the 179624 Cable Assembly, wire per 4750WD.

(j) Remove and discard existing relay group cable (transmitter control) and replace with 179448 Cable Assembly, install per Figure 6 and 3464WD.

(k) Install the 159931 Cable Clamp and the 159932 Keeper, using one 55219 Screw, and one 115594 Speed Nut. Per Figure 6.

(l) Install the two 121250 Cable Clamps using the two 55219 Screws, two 35826 Flat Washers and two 115594 Nuts. Per Figure 6.

(m) Remove paper from adhesive back of the 195035 Identification Sticker (FM-LAAC241) and apply to inside of cabinet dome.

(n) To install the 154348 Plate, remove the 151556 Knob, install the 154348 Plate using the two 151616 Drive Screws. Reinstall the 151556 Knob.

(6) 179670 Modification Kit to immobilize Cradle Assembly.

(a) Install the 179670 Modification Kit in accordance with Teletype Specification 50110S, to be found with each kit.

(7) 179953 Modification Kit to convert 160334 Transmitter Control Device to 179472.

(a) Install the 179953 Kit in accordance with Teletype Specification 50152S, to be found with each kit.

(b) Remove paper from adhesive back of the 195025 Identification Sticker (FM-179472) and apply to cover of transmitter control device.

(8) 195044 Identification Sticker

(a) Remove paper from adhesive back of the 195044 Identification Sticker (this set modified to conform with VSL245) and apply to inside of cabinet dome.

b. 195023 Modification Kit: To convert FAA ASR Set with LAK26 to be compatible with VSL245.

(1) This modification Kit is identical to the 195022 with the exception of the Keyboard Modification Kit, 195017, and the 195044 Identification Sticker being omitted. The ASR Set having an LAK26 will continue to employ the LAK26 along with the LPE1 rather than converting to the LAK28, along with the LPR50.

(2) Installation instructions for the 195022 Modification Kit shall also apply for the 195023 Modification Kit except that portion containing instructions for the 195017 Modification Kit.

(3) 195043 Identification Sticker:

(a) Remove paper from adhesive back of the 195043 Identification Sticker (this set modified to be compatible with VSL245) and apply to inside of cabinet dome.

c. 195036 Modification Kit to provide line relay and line shunt relay for auxiliary LPR for FAA.

(1) Install the line shunt relay in the lower cavity of the LAAC Cabinet per Figure 7 using the four 179484 Screws, and four 153017 Speed Nuts.

NOTE

It may be necessary to relocate the transmitter control device lower on the relay rack in order to install the line shunt and line relays.

(2) Connect the relay cables per 4748WD Areas AE and AR. Route cables along and tie to existing cables.

(3) Strap DH3 to DH9 on auxiliary reperforator base using the 157230 Strap.

(4) Install the 195039 Cable per Figure 8.

(5) The 193687 Cable is a service cord for the reperforator. Wire per 4750WD.

3. ADJUSTMENTS AND LUBRICATION

For adjustments and lubrication procedure see Teletype Model 28 Bulletins 217B, 243B, 247, and 250B.

*

*

*

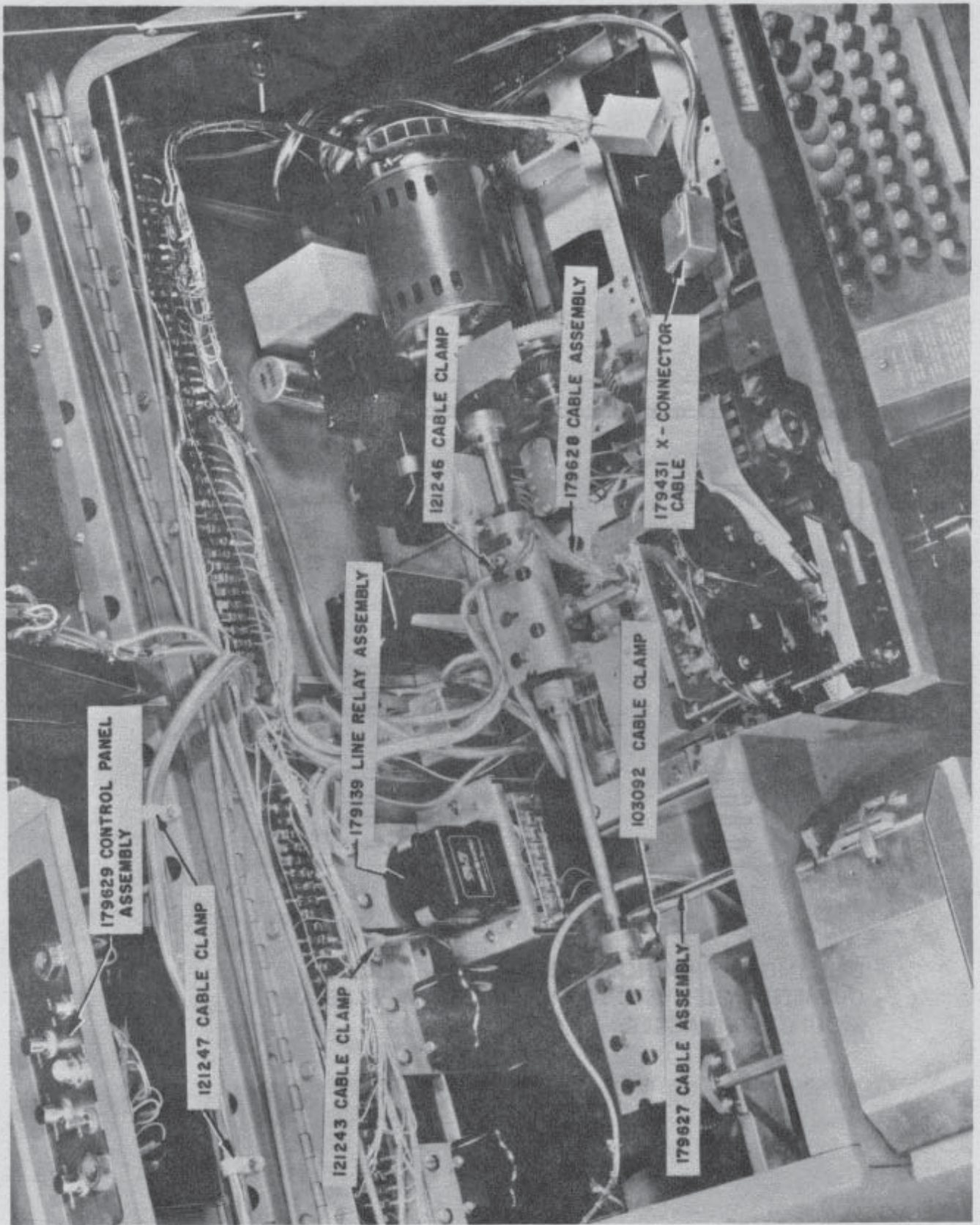

179629 CONTROL PANEL ASSEMBLY

121247 CABLE CLAMP

121243 CABLE CLAMP

179139 LINE RELAY ASSEMBLY

121246 CABLE CLAMP

179628 CABLE ASSEMBLY

103092 CABLE CLAMP

179627 CABLE ASSEMBLY

179431 X-CONNECTOR CABLE

FIGURE 1

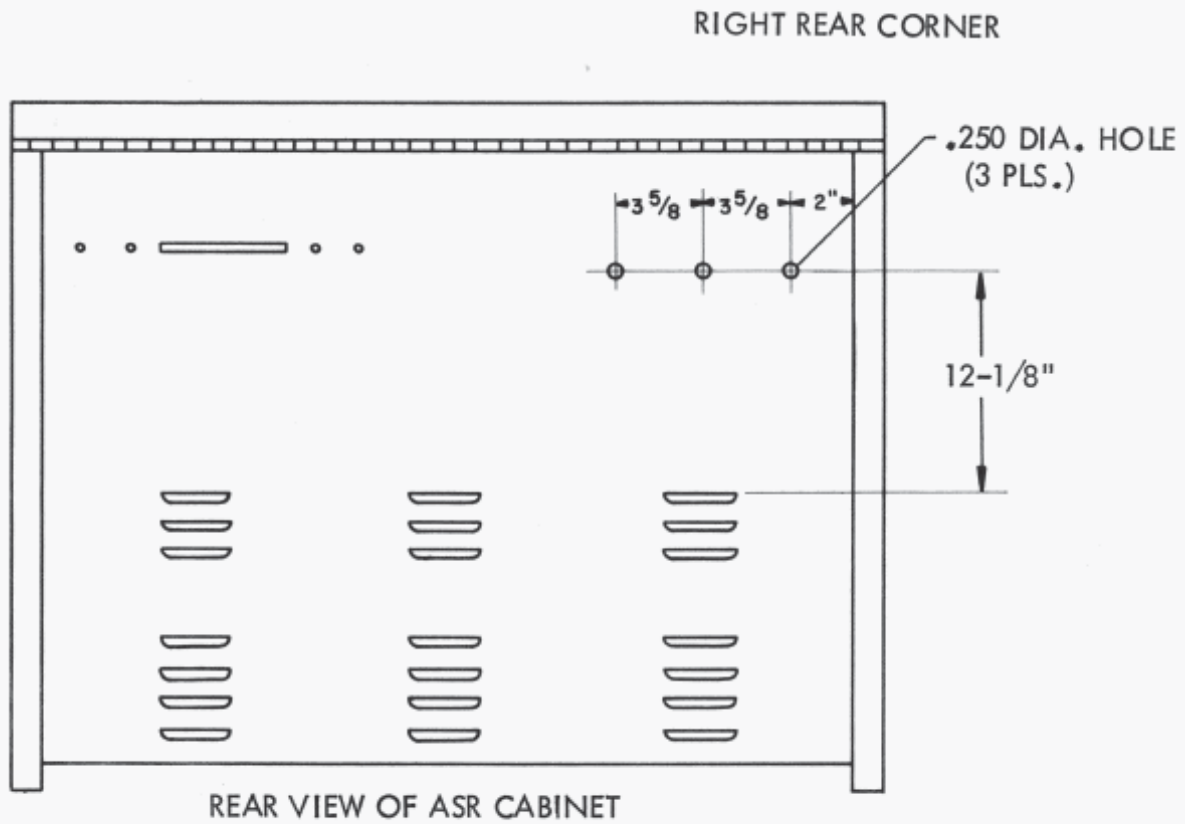

DRILLING INSTRUCTIONS FOR THE THREE .250
DIAMETER HOLES USED TO MOUNT THE 194922 RELAY
MOUNTING BRACKET.

FIGURE 2

LOCATE AND DRILL 7/32 DIA.
HOLES WITH TEMPLATE IN APPROX.
POSITION AS SHOWN.
(CAUTION: DO NOT USE TEMPLATE
FOR DRILLING. TO BE USED FOR
LOCATING PURPOSES ONLY.)

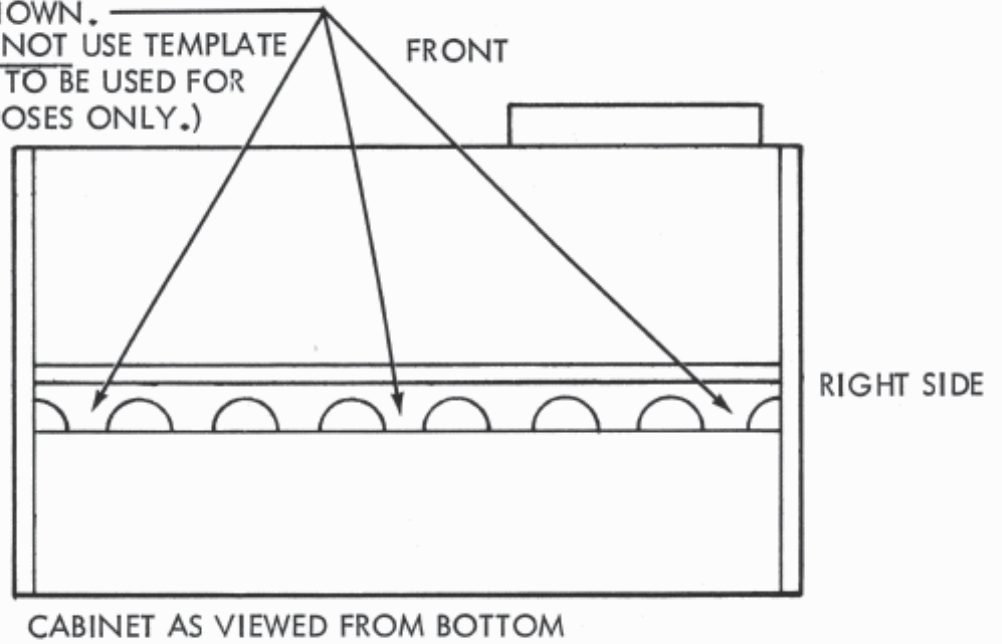

FIGURE 3

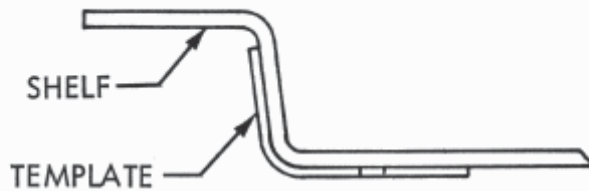

FIGURE 4

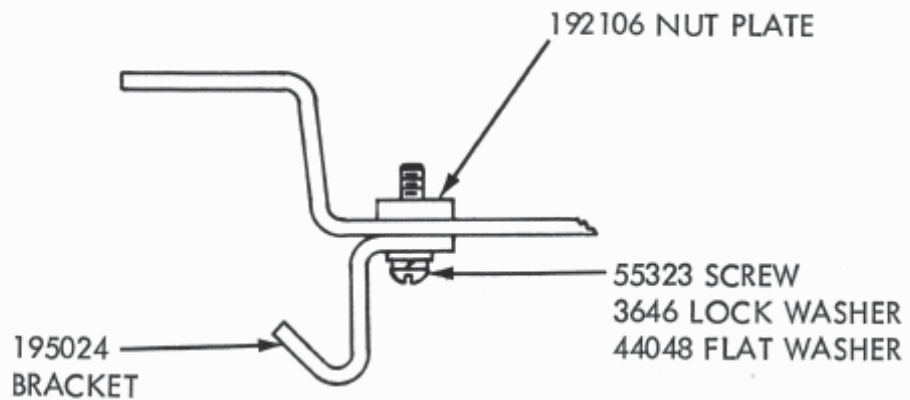
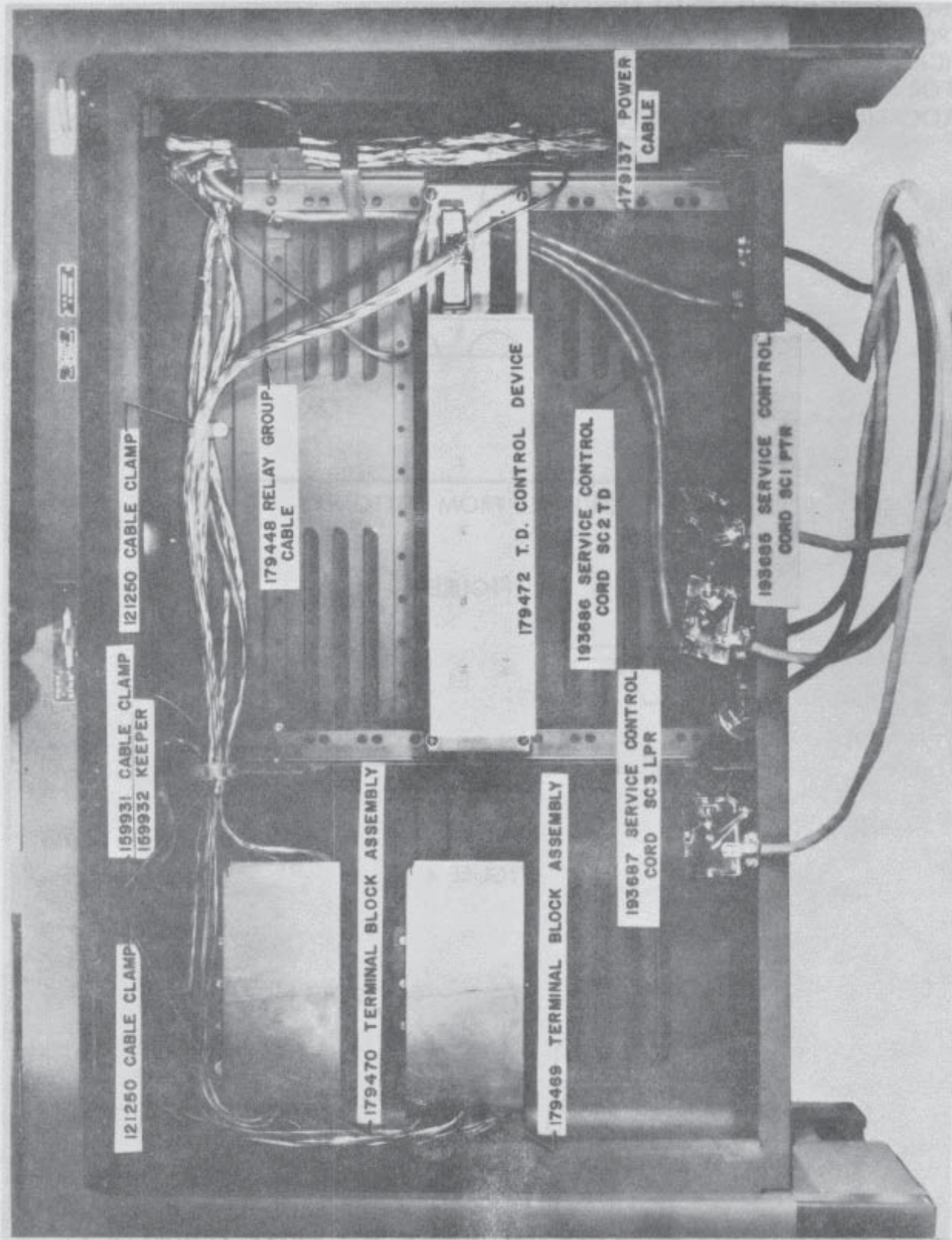

FIGURE 5

LOCATE AND IDENTIFY PARTS



PACKET

FIGURE 6

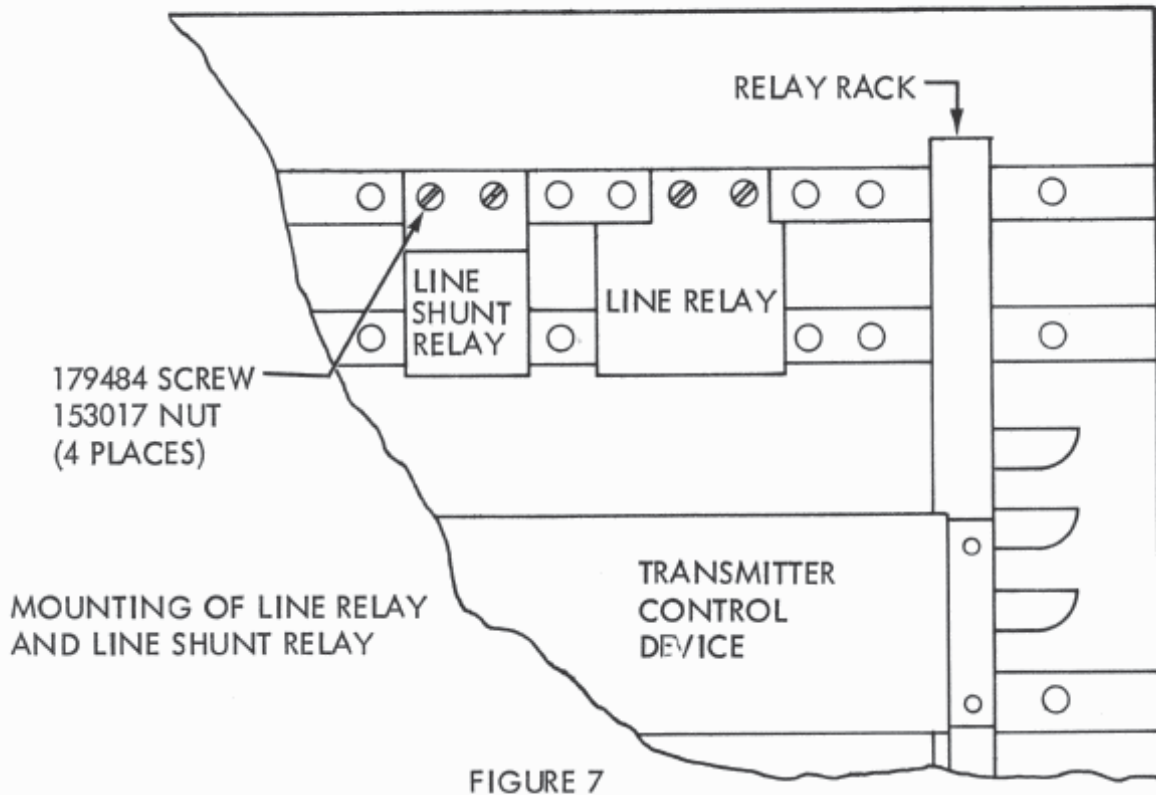

FIGURE 7

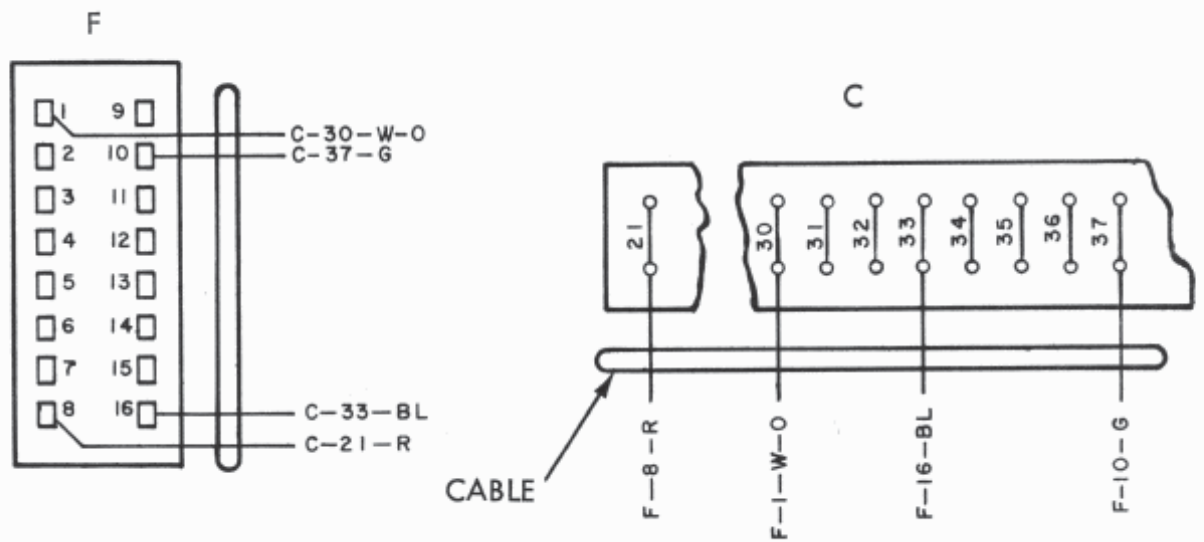

FIGURE 8